

DOCUMENT RESUME

ED 048 150

SP 007 020

TITLE Science. Grades K-6.
INSTITUTION North Carolina State Board of Education, Raleigh.
Dept. of Public Instruction.
REPORT NO PUB-410
PUB DATE 68
NOTE 202p.
EDRS PRICE MF-\$0.65 HC-\$9.87
DESCRIPTORS *Curriculum Guides, *Elementary Grades, *Elementary School Science, Grade 1, Grade 2, Grade 3, Grade 4, Grade 5, Grade 6, Kindergarten, *Science Curriculum

ABSTRACT

GRADES OR AGES: Kindergarten--grade 6. SUBJECT MATTER: Science. ORGANIZATION AND PHYSICAL APPEARANCE: The introductory section deals with objectives, scope, sequences, and units. The main body of the guide deals with activities and lists materials, with illustrations. The guide is offset printed and bound with a soft cover. OBJECTIVES AND ACTIVITIES: The guide contains the elements of a science curriculum which may be assembled into a complete sequential program. Objectives are listed for abilities and skills, scientific attitudes, and appreciations. Four hundred forty-five activities are listed on the following topics: introduction to science, living things, matter and energy, and earth and space. The teacher decides at which grade level each activity should be used. INSTRUCTIONAL MATERIALS: Details of the materials required are given with each activity. STUDENT ASSESSMENT: The guide describes briefly the purposes of evaluation and the procedures for measuring student performance and attitudes. OPTIONS: The authors acknowledge the need for flexibility and have designed the guide with this in mind. It can provide working materials for a detailed guide with possibilities for approaches which are relevant to a particular school. (MBM)

ED048150

U.S. DEPARTMENT OF HEALTH,
EDUCATION & WELFARE
OFFICE OF EDUCATION
THIS DOCUMENT HAS BEEN REPRO-
DUCED EXACTLY AS RECEIVED FROM
THE PERSON OR ORGANIZATION ORIG-
INATING IT. POINTS OF VIEW OR OPIN-
IONS STATED DO NOT NECESSARILY
REPRESENT OFFICIAL OFFICE OF EDU-
CATION POSITION OR POLICY

SCIENCE

GRADES K - 6

STATE DEPARTMENT OF PUBLIC INSTRUCTION
RALEIGH, N. C. PUBLICATION NO. 410

50 17020
ERIC
Full Text Provided by ERIC

FOREWORD

There is widespread interest in the elementary schools of North Carolina in developing improved science programs for grades K-5. This commendable interest is reflected in the numerous requests for assistance and guidance received by the Department of Public Instruction. This bulletin is designed to meet part of the needs expressed in those requests.

The contents of this bulletin represent the combined efforts of scores of scientists and hundreds of educators throughout North Carolina.

In September, 1966, several possible approaches were presented to interested and knowledgeable persons in the State. When their responses were received, an advisory committee was formed in November, 1966, to draw together the ideas which had been submitted and to make further recommendations. Serving on this committee were Miss Jessie Baxter, University of North Carolina at Greensboro; Professor William E. Fulcher, Guilford College; Mrs. Dorothy Zimmerman, Yanceyville; Mrs. Georgia G. Thayer and H. L. Forbes, High Point; Miss Millie Moore, Rocky Mount; Carl O. Foster, Greensboro; Mrs. Mary L. Gilmer, Charlotte, Mrs. Allen B. Poe, East Spencer; Mrs. Ura Jones, Shaw University; Mrs. Pauline Longest, Methodist College; and Dr. Kent Robinson, Appalachian State University.

After an approach and format had been decided upon, the writing was begun. Dr. Paul W. Welliver deserves special recognition for his contributions to the actual writing.

Leadership in developing the bulletin was provided by members of the Science Education Section of the Department of Public Instruction: Paul H. Taylor, State Science Supervisor; John M. Goode, David L. Mallette and Dr. Welliver, Associate State Science Supervisors in Science Education.

To insure the appropriateness and readability of the contents of this Bulletin, several hundred elementary school teachers from throughout the State reviewed, edited, and reacted to portions of it. This valuable assistance was coordinated with the aid of James E. Jackman, who supervised the editing and layout with the assistance of Mrs. Cynthia K. Bullock and Mrs. Lynne Hartshorn; Mrs. Patricia Bowers provided the art and layout design; and Miss Mary Lou Smith supervised the assembling and typing of the manuscript.

This elementary school science curriculum bulletin was developed and printed with financial assistance provided under the National Defense Education Act, Title III and the Elementary and Secondary Education Act, Title V.

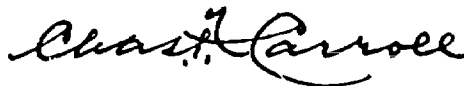

Charles F. Carroll
State Superintendent of Public Instruction

March 1968

PREFACE

What should be the nature of a science curriculum bulletin for the elementary schools of North Carolina?

This question was pondered by scientists and educators from throughout North Carolina in planning this publication. The suggestions put forth in answer to the question were numerous and varied.

Some persons have expressed a desire to have a curriculum bulletin presenting a course of study to be followed by all of the schools of the State. Others would design it to serve as a supplement to the State-adopted basal science textbook series. Still others consider the development of science curriculum to be the responsibility of local schools and therefore the State guide should be only a topical outline emphasizing scope and articulation. The idea is also held that whatever form the bulletin takes it should be adaptable for use with new content and new approaches in elementary school science.

Recognizing this broad divergence of views and the merit that attends each of them, this bulletin has been designed to be of optimum assistance in satisfying all of the requirements which might be made of it. The possible approaches to its use are many. For some, it can be viewed as containing the elements of a science curriculum which may be assembled into a complete, sequential instructional program. For others, it provides the working materials for a detailed instructional guide incorporating original approaches that are unique in design and relevant to a particular school or school administrative unit.

How should this guide be used? This depends upon the type of assistance that might be desired in developing an elementary school science program. Teachers, principals, and supervisors might begin by reading carefully the suggestions offered in the section, "How to Use This Science Bulletin." Hopefully this will open many doors to possibilities for assisting children in learning science and making it a stimulating and rewarding experience.

NILE F. HUNT

Director

Division of General Education

CONTENTS

How to Use This Science Bulletin	vii
Objectives	1
Scope	5
Sequence	11
Units	14
Activities	24
Index to Science Activities	25
I. Introduction to Science	26
II. Living Things	30
III. Matter and Energy	58
IV. Earth and Space	132
Appendices:	
A. Useful Techniques for Teaching Elementary School Science	166
B. Safety in Science Teaching	178
C. Equipment for Science Instruction	181
D. Illustrations of Commonly Used Science Equipment	188
E. Evaluation of Elementary School Science Instruction	193
F. Professional References in Elementary School Science Education	194

HOW TO USE THIS SCIENCE BULLETIN

This curriculum bulletin for elementary school science has been designed to assist teachers, supervisors, and administrators in developing effective instructional programs in science. To accomplish this major objective, it offers suggestions which should help in the principal phases of program planning:

- Defining objectives**
- Developing a scope of instructional topics**
- Establishing a sequence of topics**
- Developing teaching units**
- Devising evaluation procedures**
- Setting up activities**
- Locating information**

It sets forth sample objectives to be used in developing a significant list of behavioral objectives; outlines several procedures for developing a scope for the program; offers assistance in arranging a meaningful sequence, in developing comprehensive units of study and a broad and varied set of practices for evaluating the progress of children in their study and understanding of science as well as the effectiveness of the instructional program; and provides a wealth of information, activities, and resources for enriching the elementary school science program.

The purpose of this curriculum bulletin is to assist each school and school administrative unit in developing a coordinated program in elementary school science which is suitable to its own needs and resources. The following steps are suggested as a framework in which to work:

1. Read the Preface of this bulletin carefully to become acquainted with its purpose, approach, and underlying philosophy.
2. Contact the Supervisor of Science Education, State Department of Public Instruction, Raleigh, 27602, for assistance in preparing a science curriculum development project. The Science Education Section of the Department has developed materials which, along with this bulletin, are designed to assist a supervisor or principal in working with a group of teachers on the development of a science instructional program.
3. Decide on the size of the group which will be working together on this curriculum project. The minimum size of the group should be the faculty of one school. However, the faculties of several schools, of an entire school administrative unit, or of several administrative units may want to work together. An effort should be made to involve local kindergarten teachers in the project.
4. Gather all available resources to provide background and assistance in developing a course of study for grades K-6.
5. Prepare, with the guidance of this curriculum bulletin and other available resources, the objectives, scope, and sequence to be used in the schools involved in the study. These may be strongly influenced

by a previously developed local course of study, the basal science textbook series, the suggestions given in this bulletin, one of the new nationally developed elementary school science curricula, or some other source.

Any school wishing to set up its program around one of the new, nationally developed science curriculum projects may contact the State Supervisor of Science Education for assistance. The Department of Public Instruction strongly supports the wise use of these programs.

6. When the objectives, scope, and sequence have been developed, each teacher involved in the curriculum project should insert them in the back of the curriculum bulletin.*
7. Once the sequence for grades K-6 has been established, examine the activities which are provided in this bulletin, and in the color block beside each activity, write the grade for which the activity seems most appropriate.
8. Appendix C provides a list of equipment required to perform the activities which are described in this bulletin. It also contains a more general elementary school science equipment list. Space is provided beside each item for appropriate notations. Use this list for keeping an inventory and for preparing equipment orders.
9. Teachers of each grade should, as a group and in cooperation with teachers of other grades, expand the objectives, scope, and sequence as they apply specifically to their particular grades. This additional information should also be inserted into the back of the curriculum bulletin.* Include with the grade sequence a list of the activities described in this sourcebook which have been designated as appropriate to the topics that are included.
10. Specific, detailed plans should be made for the development of coordinated teaching units and evaluation procedures.
11. All teachers should become acquainted with the resources provided in the curriculum bulletin for use in more effective instruction.
12. When a science curriculum development project such as the one described above has been undertaken, this bulletin should be the center of science instruction for each teacher. Inserted in the back of the bulletin there should be a complete program of science studies for grades K-6 with additional information relative to the grade with which the teacher is working.
13. Curriculum development is a continuous process. Materials which are developed and inserted in this bulletin should constantly be subject to additions and revisions. Wide margins are provided for notes on effective teaching practices and newly discovered methods which may be used in future years.
14. Each teacher should regularly evaluate his effectiveness and alter his program and approach to bring about improvement. Assistance in a teacher's self-evaluation of his science instructional program is provided in Appendix E of this bulletin. Classroom teachers are urged to use this checklist frequently.
15. Keep the State Science Supervisor informed of your use of this bulletin. This information will enable the Department of Public Instruction to be of even greater assistance to you in the future.

* Suggestions on ways to insert materials will be found on the last page of the bulletin, inside the back cover.

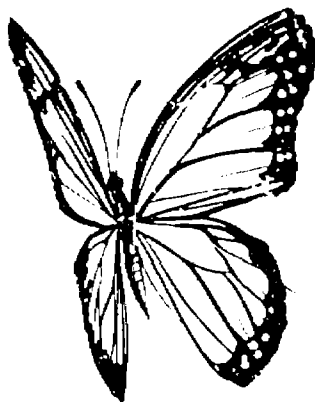

OBJECTIVES

Well-formulated objectives are essential to the development of an effective elementary school science program. They help to establish the aims, the goals, and the directions of the program. Objectives should provide—

A clear statement of specific behavioral changes which the teacher is attempting to bring about in students through instruction and participation in appropriate activities

A guide to the selection of course content

A basis for selection of appropriate instructional procedures and learning activities

A basis for evaluation of student achievement and program effectiveness.

Objectives should take into account a variety of factors which are important to science curriculum planning and good science teaching:

1. The nature of science.
2. The nature of the learner.
3. The nature of the teacher.
4. The nature of learning.
5. The nature of the curriculum.
6. The nature of the social structure.

from *Theory Into Action in Science Curriculum Development*
National Science Teachers Association
Washington, D. C. 1964

Objectives can express goals in general but meaningful terms:

1. To help children develop concepts, principles, and generalizations of value to them in understanding and solving their problems.
2. To help children cultivate scientific attitudes, such as critical mindedness, willingness to seek and act upon reliable evidence, and intellectual honesty.
3. To help children acquire or develop scientific ways of working, including planning intelligently, observing carefully, and forming tentative conclusions.
4. To help children explore new interests which will lead to the satisfactions of discovery.
5. To help children acquire those skills and techniques necessary to gain further information, such as reading science content with understanding, making accurate observations of events, and performing various science activities.
6. To help children develop social attitudes and appreciations needed in a democracy, such as growth in social behavior and willingness to assume adequate roles in present and future society.

from: *Policies for Science Education*
F. L. Fitzpatrick, Editor
Bureau of Publications,
Columbia University 1960

Objectives can express behavioral goals in detail:

Abilities and Skills

1. Make careful and complete plans for solving problems.
2. Develop theories and make and test predictions on the basis of these theories.
3. Find or devise experiments that will solve problems or answer questions.
4. Predict the outcome of an experiment, and offer reasons to justify the prediction.
5. Perform experiments involving simple cause-and-effect relationships, and describe or explain satisfactorily what happened.
6. Plan and execute experiments carefully.
7. Make accurate measurements and readings.
8. Manipulate science equipment satisfactorily.
9. Observe accurately and with discrimination.
10. Observe and describe similarities and differences in experimental behavior and in objects and their characteristics.
11. Distinguish between pertinent and irrelevant observations and information.
12. Make valid and reliable comparisons.
13. Make quantitative as well as qualitative observations.
14. Organize and classify observations.
15. Explain phenomena on the basis of truth and logic, rather than on the basis of superstition and wishful thinking.
16. Distinguish fact from fantasy.
17. Apply previously learned concepts to interpret new phenomena.
18. Predict what will happen when conditions are changed.
19. Where experimentation is impossible or unfeasible, determine other appropriate methods of investigation.
20. Distinguish between science books that are read for fun and those that are read for reliable information.
21. Use the table of contents, index, and glossary of science texts and references.
22. Read science content with understanding.
23. Abstract major concepts and understandings from the science content in texts and references.
24. Read and interpret simple charts, tables, and graphs.
25. Organize observations or reading into effective oral or written reports.
26. Develop the verbal and written skills of communication used by scientists.
27. Participate actively in group discussion.
28. Stay close to the topic being discussed.

29. Formulate clear and intelligent questions.
30. Report clearly, concisely, and accurately.
31. Listen intelligently.
32. Work together in small or large groups.
33. Cooperate with others when planning an investigation.
34. Persevere in projects that are undertaken.

Scientific Attitudes

1. Open-mindedness.
2. Willingness to change one's mind in the light of new evidence.
3. Willingness to allow others to question and challenge one's ideas.
4. Suspended judgment, which is the reservation of decisions until all the available evidence has been collected.
5. Reluctance to generalize on the basis of one experiment or limited evidence.
6. Respect for the ideas, opinions, and ways of life of others.
7. Awareness that there is a difference between facts and opinions.
8. Unwillingness to accept statements as facts unless they are backed by sufficient proof.
9. Reluctance to allow decisions to be affected by personal likes or dislikes, anger, fear, and ignorance.
10. Unwillingness to compromise the truth.
11. Development of the habit of explaining things in a scientific manner.
12. Desirability of checking thinking by doing experiments or consulting reliable books and people.
13. Going to reliable sources for evidence.
14. Awareness that sometimes printed matter is not accurate or correct.
15. Willingness to cooperate.
16. Curiosity about the world in which we live.
17. Unwillingness to believe in superstitions.
18. Awareness that truth itself never changes, but that our concept of what is true continues to change as our knowledge increases.

Appreciations

1. The role science plays in our daily lives.
2. The many ways that science can be used to explain the environment around us.
3. The impact of science and technology on our civilization.
4. The influences of science upon man's way of thinking, his relations with others, his religion, and his social responsibility.
5. The role that problem solving and critical thinking can play in our personal habits, attitudes, and relationships.
6. The concept that science is the result of human endeavor and flourishes best when there is intellectual freedom.
7. The constant striving of scientists to know more about the world.
8. The contributions of scientists to the world we live in.
9. The tools and techniques of science.
10. The orderliness of nature and of natural laws.
11. The ever-changing nature of science.
12. The beauty in nature.

from *Science for the Elementary School*
Edward Victor
Macmillan Company
New York 1965

Using all sources available to you, prepare a list of objectives for the science instructional program in your school. Discuss it thoroughly with other teachers in your school and develop a list of objectives which all of you will use. Insert a copy in the back of this bulletin in the manner suggested on page 196.

Develop a list of objectives which apply to science instruction at the grade level which you are teaching. Discuss it thoroughly and share ideas with other teachers who work at the same grade level. Insert a copy in the back of this bulletin, in the manner suggested on page 196.



SCOPE

Careful consideration should be given to determining the *scope* of the elementary school science program—its length, breadth, and depth. The scope can be developed along any of several lines, but an adequate statement of scope—

Affords a complete view of subject matter content

Places topics in the perspective of the total science program

Provides a basis for developing a sequential program in grades K-6

Indicates relationships between topics.

Scope can be developed in terms of important processes which are basic to science.

- | | |
|-------------------------------|----------------------------|
| 1. Observing | 3. Predicting |
| 2. Classifying | 9. Interpreting data |
| 3. Using space-time relations | 10. Controlling variables |
| 4. Using numbers | 11. Defining operationally |
| 5. Communication | 12. Formulating hypotheses |
| 6. Measuring | 13. Experimenting |
| 7. Inferring | 14. Formulating models |

from *Science, A Process Approach*
American Association for the Advancement of Science
Commission on Science Education Newsletter
Volume 2, Number 1, October 1965

Scope can be developed in terms of comprehensive conceptual schemes.

1. All matter is composed of units called fundamental particles: under certain conditions these particles can be transformed into energy and vice versa.
2. Matter exists in the form of units which can be classified into hierarchies of organizational levels.
3. The behavior of matter in the universe can be described on a statistical basis.
4. Units of matter interact. Electromagnetic, gravitational, and nuclear forces form the basis of all ordinary interaction.
5. All interacting units of matter tend toward equilibrium states in which the energy content (enthalpy) is a minimum and the energy distribution (entropy) is most random. In the process of attaining equilibrium, energy transformations or matter transformations or matter-energy transformations occur. Nevertheless, the sum of energy and matter in the universe remains constant.
6. One of the forms of energy is the motion of units of matter. Such motion is responsible for heat and temperature and for the states of matter: solid, liquid, and gaseous.
7. All matter exists in time and space, and since interactions occur among its units, matter is subject in some degree to changes with time. Such changes may occur at various rates and in various patterns.

from Theory Into Action in Science Curriculum Development
National Science Teachers Association
Washington, D. C. 1964

Scope can be developed in terms of general areas of science.

1. Introduction to science
2. Living things
3. Matter and energy
4. Earth and space

Scope can be developed around a combination of these and other approaches.

The following is a sample scope of science topics for grades K-6. Use it in any way in which it might be helpful in developing a scope of science topics for instruction in your school.

SCOPE

ELEMENTARY SCHOOL SCIENCE K-6

I. INTRODUCTION TO SCIENCE

- A. What science is
- B. How science helps us
- C. What scientists are like
- D. How scientists think and work
 - 1. Scientific methods
 - 2. Scientific attitudes
 - 3. Scientific skills and abilities
- E. Branches of science
 - 1. Astronomy
 - 2. Biology
 - 3. Chemistry
 - 4. Geology
 - 5. Physics
- F. Tools of science
 - 1. Scientific apparatus
 - 2. Scientific vocabulary
 - 3. Measurements and computation
 - 4. Publications
 - 5. Professional societies
- G. Economic importance of science
- H. History of science
- I. Outstanding scientists—past and present
- J. Differences between pure and applied science

- c. Food habits
- d. Reproduction
- e. Growth and development
- f. Mobility
 - g. Helpful and harmful effects
- 2. How animals are alike and different
 - a. Size and shape
 - b. Color
 - c. Habits
 - d. Movement
 - e. Growth
 - f. Homes
 - g. Sounds
 - h. Reproduction
- 3. Classifications
 - a. Invertebrates
 - b. Vertebrates
- 4. One-celled animals
- 5. Needs of animals
 - a. Water
 - b. Food
 - c. Oxygen
 - d. Shelter
- 6. Care of animals and their young
- 7. Adaptations to environment
 - a. Food
 - b. Homes
 - c. Coats
 - d. Protective coloration
 - e. Hibernation
 - f. Migration
- 8. Defense mechanisms
- 9. Helpful and harmful animals
- 10. Genetic changes in animals
 - a. Selective breeding
 - b. Hybrids
 - c. Natural changes
- 11. Interdependence of animals and plants
 - a. Balance of nature
 - b. Man's intrusion on the balance of nature
 - c. Man's attempt to restore the balance of nature
 - d. Conservation

II. LIVING THINGS

- A. Our bodies
 - 1. Parts of our bodies
 - 2. Functions of our body parts
 - 3. Body systems
 - a. Structure of systems
 - b. Function of systems
 - 4. Body care
 - a. Cleanliness
 - b. Exercise
 - c. Rest and sleep
 - 5. Health and sanitation
 - a. Good personal health habits
 - b. Good public health habits
 - c. Germ theory of disease
 - d. Symptoms of common diseases
 - e. Spread of communicable diseases
 - f. Control of communicable diseases
 - g. Immunization
 - h. Sanitation
 - 6. Food
 - a. Kinds
 - b. Purpose
 - c. Four basic food groups
 - (1) What each contains
 - (2) Function
 - d. Need for a balanced diet
 - e. Good eating habits
- B. Animals
 - 1. Animals around us
 - a. Physical description
 - b. Habitat

- C. Plants
 - 1. Plants around us
 - a. Structure
 - b. Habitat
 - c. Reproduction
 - d. Uses
 - 2. Uses of plants
 - 3. Parts and functions of plants
 - a. Roots
 - b. Stems
 - c. Leaves
 - d. Flowers
 - e. Fruits
 - f. Seeds

4. Classification of plants
 5. What plants need to live and grow
 - a. Air
 - b. Water
 - c. Light
 - d. Proper temperature
 - e. Proper soil
 6. Life processes of plants
 - a. Photosynthesis
 - b. Respiration
 - c. Transpiration
 - d. Reproduction
 - e. Tropisms
 7. Reproducing plants
 - a. Seeds
 - b. Bulbs
 - c. Roots
 - d. Stems
 - e. Cuttings
 - f. Leaves
 8. Genetic changes in plants
 - a. Selective breeding
 - b. Hybrids
 - c. Natural changes
 9. Conservation
8. Oxidation
 - a. Slow and rapid
 - b. Rust
 - c. Flame and smoke
 - d. Conditions for making fire
 - e. Conditions for extinguishing fire
 - f. Fuels
 - g. Spontaneous combustion
 - h. Fire extinguishers
 - i. Fire safety

- E. Heat energy
 1. Heat sources
 2. Molecular theory of heat
 - a. Temperature
 - b. Expansion and contraction
 - c. States of matter
 3. Temperature measurements
 - a. Thermometers
 - b. Temperature scales
 4. Heat transfer
 - a. Conduction
 - b. Convection
 - c. Radiation
 5. Home temperature control
 6. Heat engines

III. MATTER AND ENERGY

A. Matter

1. Kinds of matter
2. Common materials
3. Properties of matter
4. States of matter
5. Solutions
6. Crystals
7. Atomic structure
8. Elements
9. Molecules and atoms

B. Energy

1. Potential and kinetic
2. Forms of energy
3. Transformation of energy
 4. Sources of energy
 5. Relationship between matter and energy

C. Atomic energy

1. Nuclear structure
2. Nuclear radiation
3. Nuclear energy
4. Fission and fusion
5. Uses of atomic energy

D. Chemical energy

1. Chemical and physical change
2. Chemical changes in matter
3. Mixtures and compounds
4. Chemical symbols
5. Chemical formulas
6. Simple chemical equations
7. Common chemical compounds
 - a. Acids
 - b. Bases
 - c. Salts
 - d. Oxides

F. Wave energy

1. Wave properties
 - a. Reflection
 - b. Refraction
 - c. Interference
 - d. Diffraction
2. Light
 - a. Wave properties of light
 - b. Shadows
 - c. Transparent, translucent, opaque, and reflecting materials
 - d. Particle properties of light
 - e. Visible, infrared, and ultraviolet light
 - f. Speed of light
 - g. Sources of light
 - h. Laws of reflection
 - i. Mirrors
 - j. Laws of refraction
 - k. Lenses
 - (1) Eye
 - (2) Camera
 - (3) Optical instrument
 - l. Spectrum
 - m. Colored lights
 - n. Colored pigments
3. Sound
 - a. Producing sound
 - b. Wave nature of sound
 - c. Transmission of sound waves
 - d. Speed of sound
 - e. Characteristics of sound
 - (1) Pitch
 - (2) Intensity
 - (3) Quality

- f. Music
- g. Musical instruments
- h. Ear
- i. Voice
- j. Sound phenomena

G. Mechanical energy

- 1. Machines
 - a. Examples of machines
 - b. Simple machines
 - c. Compound machines
 - d. How machines help us
 - (1) Change force
 - (2) Change direction
 - (3) Change speed and displacement
- 2. Work
- 3. Mechanical advantage
- 4. Friction
- 5. Efficiency
- 6. Motion
 - a. Newton's laws of motion
 - b. Speed
 - c. Acceleration
- 7. Mechanics of fluids
 - a. Types and nature of fluids
 - b. Pascal's law
 - c. Bernoulli's principle
 - d. Flotation

H. Electrical energy

- 1. Magnets
 - a. Natural magnets
 - b. Attraction and repulsion
 - c. Magnetic fields
 - d. Making magnets
 - e. Electromagnets
 - f. Compass
 - g. Uses of magnets
- 2. Static electricity
 - a. Ways of producing static electricity
 - b. Nature of static electricity
 - c. Laws of electrostatic charge
- 3. Current electricity
 - a. Nature of current electricity
 - b. Methods of producing electricity
 - c. Series and parallel circuits
 - d. Alternating current and direct current
 - e. Conductors and nonconductors
 - f. Switches
 - g. Short circuits
 - h. Electrochemistry
 - i. Uses of electricity
 - j. Electric motors
 - k. Electronics
 - l. Communication devices
 - m. Safety

IV. EARTH AND SPACE

A. The earth

- 1. History of the earth
- 2. Land formations
- 3. Water formations

- 4. Earth's crust and layers
- 5. Rocks
 - a. Igneous
 - b. Sedimentary
 - c. Metamorphic
- 6. Minerals
- 7. Soil
 - a. Formation
 - b. Types
 - c. Testing
 - d. Enrichment
 - e. Conservation
- 8. Forces changing the earth
 - a. Weathering—physical and chemical
 - b. Erosion
 - c. Earthquakes
 - d. Volcanoes
 - e. Works of man
- 9. Soil and water
 - a. Cultivation
 - b. Irrigation
 - c. Drainage
- 10. Useful natural resources
 - a. Coal
 - b. Oil and gas
 - c. Minerals
 - d. Conservation

B. The earth's atmosphere

- 1. Air
 - a. Properties of air
 - (1) Air has weight
 - (2) Air occupies space
 - b. Where air is found
 - c. Components of air
 - d. Structure of the atmosphere
- 2. Weather
 - a. Differences between weather and climate
 - b. Factors which determine climate
 - (1) Basic factors
 - (a) Temperature
 - (b) Wind
 - (c) Humidity
 - (2) Local factors
 - (a) Large bodies of water
 - (b) Ocean currents
 - (c) Winds
 - (d) Altitude
 - (e) Topography
 - c. Kinds of weather
 - d. How weather affects us
 - e. Air masses
 - f. Weather forecasting
 - g. Water cycle
 - h. Humidity
 - i. Formation of precipitation
 - (1) Clouds
 - (2) Rain
 - (3) Snow
 - (4) Sleet
 - (5) Hail
 - (6) Dew

- (7) Frost
 - (8) Fog
- C. Space
- 1. Solar system
 - a. Sun
 - (1) Nature of the sun
 - (2) Distance to the sun
 - (3) Position of the solar system
 - (4) Source of energy
 - (5) Effects on earth
 - (a) Heat and light
 - (b) Day and night
 - (c) Year
 - (d) Seasons
 - (e) Importance to life
 - b. Moon
 - (1) Nature of moon
 - (2) Motion around earth
 - (3) Phases
 - (4) Tides
 - (5) Eclipses
 - c. Planets
 - (1) Nature of planets
 - (2) Names of planets
 - 2. Comets
 - 3. Meteors and meteorites
 - 4. Universe
 - a. Stars
 - b. Constellations
 - c. Galaxies
 - d. Instruments for studying stars
- D. Space explorations
- 1. Rockets
 - 2. Satellites
 - 3. Space travel

Using all resources available to you, prepare a scope for the science instructional program in your school. Discuss it thoroughly with the other teachers in your school and develop a scope of science topics which you will use. Insert a copy in the back of this bulletin in the manner suggested on page 196 .

In developing a scope of science topics for the elementary schools, it may prove helpful to take into consideration the types of science courses available to the children beyond grade six. The following are courses which are available to children as they continue their study of science in the secondary schools of North Carolina. Pupils in grades 7-10 are normally enrolled in a science course.

Grade 7	Life Science	Grade 11 or 12	Chemistry
Grade 8	Earth Science	Grade 11 or 12	Physics
Grade 9	Physical Science	Grade 11 or 12	Applied Science
Grade 10	Biology	Grade 11 or 12	Advanced Courses



SEQUENCE

Designing the *sequence* of the science program in grades K-6 means determining the order, grade level, and relationship of instructional topics which will provide for a smooth, sequential development of scientific understandings, skills, and attitudes on the part of the students. The sequence forms the basis of a well-articulated program in each grade, for coordination of science instruction, and for elimination of unnecessary duplication and repetition in the program.

Sequence planning aims at the following goals:

A structured arrangement of experiences which promote growth in the master of important scientific processes

An orderly development of understandings and concepts which contribute to the expansion of fundamental conceptual schemes

A carefully organized arrangement of science topics to insure completeness of coverage with a minimum of repetition.

Sequence can be developed around a combination of these and other approaches.

Topics in a scope can be conveniently divided between grades by means of a *sequence chart*. The following example of such a chart uses topics included in the sample scope in the previous section.

SAMPLE SEQUENCE CHART

TOPICS	GRADE LEVEL						
	K	1	2	3	4	5	6
I. Introduction to Science	X	X	X	X	X	X	X
II. Living things							
A. Our bodies	X		X		X		X
B. Animals	X	X		X		X	
C. Plants	X	X		X		X	
III. Matter and Energy							
A. Matter	X	X		X		X	
B. Energy			X		X		X
C. Atomic energy			X		X		X
D. Chemical energy		X		X		X	
E. Heat energy		X		X		X	
F. Wave energy			X		X		X
G. Mechanical energy		X		X		X	
H. Electrical energy	X		X		X		X
IV. Earth and Space							
A. Earth	X		X		X		X
B. Earth's atmosphere		X		X		X	
C. Space	X	X		X		X	
D. Space exploration			X		X		X

What topics are generally taught in each grade? A study of science curricula throughout the United States revealed the following topics to be the ones most commonly investigated at the grade level indicated.

KINDERGARTEN

Weather and seasons (observations)
 Interrelationships of plants and animals
 The sun—our principal source of energy
 Classification of living things
 How plants are alike and different
 Farm animals
 Care of pets
 Indoor plants
 Earth and stars

How plants and animals get their food
 How animals protect themselves and their young
 Animal babies
 Birds and insects in winter
 Effects of seasons on lives of people, animals, and plants
 Weather and how it affects our earth
 The sun
 The moon
 The earth and sky
 Simple constellations
 Gravity
 Air and water
 Magnets and forces
 Exploring space

GRADE ONE

Animals and pets
 Where plants live
 Where animals live
 Air and water
 Seeds, bulbs, plants, and flowers
 Day and night
 Sun, moon, and stars
 Seasons and weather
 Fire and temperature
 Machines

GRADE THREE

How the face of the earth is changed
 Motions of the earth
 Earth satellites
 Stars and moon
 Weather
 Rocks and soil
 How animals serve man

GRADE TWO

Animals of our neighborhood
 Useful and harmful animals

Plants and animals of the desert
Plants and animals of the sea
Life cycle of animals
Common birds, trees, and flowers
Forest plants
Conservation
Ocean life
Magnets and electricity
Great names in science

GRADE FOUR

Plants and animals of the past
Earth and its history
Balance of nature
Structure of plants
How weather influences physical life
Causes of seasons
Solar system and the universe
Climate
Rocks and minerals
Plants and seeds
Living in space
Great names in science

GRADE FIVE

How living things adapt themselves
Plants and their foods

Properties of air
Time and seasons
Trees
Sun
Milky Way
Great names in science
Use and control of electricity
Space
Conservation

GRADE SIX

Helpful and harmful insects
Improvement of plants and animals
Classification of living things
Food for growth and energy
Energy and simple machines
Climate and weather
Motors and engines
Electricity and its uses
Simple astronomy
Elements of sound
Light and heat
Atomic and nuclear energy
Inventions and discoveries
Great names in science
Space and space travel
Conservation

from *Typical Courses of Study*
William H. Nault
Field Enterprises Educational Corporation
Chicago, Illinois 1966

Based upon the scope which you have already prepared and using all resources available to you, prepare a sequence for the science instructional program in your school. Discuss it thoroughly with the other teachers in your school and develop a sequence which you will all use in your science instruction. Insert a copy in the back of this bulletin in the manner suggested on page 196.

Expand the sequence for the grade which you teach in order to include more details of the science instructional program which your class will explore. Discuss it thoroughly and share ideas with other teachers who work at the same grade level. Insert a copy in the back of this bulletin in the manner suggested on page 196.

It is recommended that this sequence be put in a form which can serve as a useful resource for unit development. This form should include the topics to be studied, specific objectives which may relate to each topic, references to the activities in this bulletin which are appropriate to each topic, and other pertinent information.

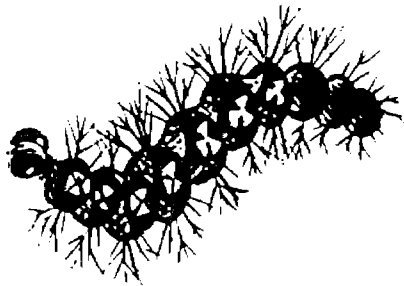

UNITS

Well-planned teaching units in an elementary school science program help to develop its structure, direction, unity, and correlation with other subjects and programs and with resources.

Use of teaching units makes it possible to develop an instructional program divided into broad segments which center on meaningful topics, concepts, and goals. They provide opportunities for teacher-pupil planning and serve as a framework for bringing together long-range goals, specific objectives, broad concepts, important topics, significant activities, meaningful techniques and procedures, and appropriate resources. They provide a basis for correlation between subjects, for student evaluation, and for curriculum evaluation and revision.

Teaching units can include a variety of factors that are basic to effective instruction.

1. Introduction or overview.
2. Objectives for the unit.
3. Content (problems, concepts, or subject matter).
4. Activities and resources.
5. Evaluation materials.

from *Curriculum Planning for Modern Schools*
J. G. Saylor and W. M. Alexander
Holt, Rinehart and Winston, Inc.
New York 1966

Teaching units can be developed in a variety of useful forms.

Unit Content and Organization

- | | |
|--------------------------|---------------------------|
| 1. Overview | 7. Bibliography |
| 2. Teacher's objectives | 8. New science vocabulary |
| 3. Initiating activities | 9. Culminating activities |
| 4. Pupil objectives | 10. Evaluation |
| 5. Learning activities | 11. Work sheets |
| 6. Materials | |

SAMPLE WORK SHEET FOR UNIT ORGANIZATION

Initiating activities and pupil objectives	Basic Science Information	Learning Activities	Supplies Materials Equipment	Texts and References	Evaluation

from *Science for the Elementary School*
Edward Victor
Macmillan Company
New York 1965

SAMPLE UNIT

The following unit was developed by the teacher of a fourth grade class. This outline is provided as an example of one method for designing a science instructional unit. It is not presented here with the intention that it be used, as is, for an actual teaching unit.

WEATHER

(Grade 4)

prepared by

**Herman L. Forbes
Fairview Street School
High Point, North Carolina**

I. Objectives

- A. To explore the nature and causes of weather phenomena.
- B. To stimulate and broaden interest in science through participation in weather observations, activities, and study.
- C. To provide experience in the use of scientific approaches and techniques through observation, measurement, analysis and prediction of the weather.
- D. To promote a scientific attitude toward such factors as weather lore and the reliability of weather forecasts.
- E. To provide opportunities to critically examine information about weather and to use this information in solving problems.
- F. To develop an awareness of the effect of weather on our daily lives and an understanding of the importance of weather predictions.

II. Concepts and Content

- A. Many different kinds of weather are occurring all over the world at the same time.
- B. The sun heats the land, water, and air of the earth.
- C. As the earth turns, the part of the earth that faces the sun is in the daylight. Everything becomes warmer as the sun shines on it.
- D. As each part of the earth turns away from the sun, night comes to that part, and everything there begins to cool.
- E. One reason for the difference between summer and winter weather is the difference in the number of hours of sunlight.
- F. When clouds hide the sun, which is always shining, the weather becomes cooler.
- G. Water does not heat as quickly as land. In the sunlight, the air over water is cooler than that over land. At night, land cools more quickly than water.
- H. Air expands and becomes lighter when it is warmed.
- I. When light, warm air meets heavy, cool air, it is pushed up by the moving cool air. This action keeps the air moving.
- J. On a sunny day the cool air over the water flows under the warmer land air and pushes it up. This is called a sea breeze.
- K. At night, the air over land cools more quickly than the air over water. The air over land flows under the warm air over the water and pushes it up. This is called a land breeze.

- L. There are winds everywhere in the world. The force of the wind depends on the difference in temperature between masses of warm and cool air.
- M. Water is always passing into the air in the form of vapor. It comes down as rain, snow, hail, sleet, or mist.
- N. Dew is little drops of water which condense on cool objects from water vapor in the air.
- O. Clouds are formed when water vapor collects in little drops high in the air.
- P. Fog is a cloud near the ground.
- Q. As clouds cool, tiny drops of water join to form big drops, which become heavy and fall down as rain.
- R. When raindrops fall through very cold air, they freeze and fall as sleet.
- S. Hailstones are formed when a strong wind blows sleet upward again and again, adding a layer of ice each time. Finally, the hailstones are too heavy for the wind to keep up and they fall to the earth.
- T. When a cloud becomes very cold, the water vapor in it forms snowflakes instead of raindrops.
- U. Water passes into the air and falls back again in many forms. It is used over and over again by living things on earth.

III. Skills

Develop the ability:

1. To use simple weather instruments.
2. To accurately observe and measure weather phenomena.
3. To draw accurate conclusions about the weather from data gathered.
4. To use many types of information about the weather for making a valid analysis and prediction.
5. To follow specific printed instructions in using weather observation instruments, in making meteorological measurements, and in performing other related activities.
6. To use reading and language skills in gathering information, in discussing meteorological events, and in studying the weather.
7. To build and use a vocabulary of meteorological terms.

IV. Materials

Thermometers	2	Pin
Sauce dishes (same size)	2	Paper clip
Water		Pencil
Glass jars (with tops)	2	Stapler
Tissue paper		Lamp or heater
Dark colored paper		Ice cubes
Dry soil		Milk bottle
Drinking straw		Hot water
Paper, 3" by 4"		Magnifying glass
Mirror		Globe
Dark book		Shoe boxes
Pane of glass		Towel

V. Introductory Activities

- A. Display books, maps, and reports about the weather.
- B. Display pictures of different kinds of weather. Ask pupils to point out the things in the pictures which indicate types of weather.
- C. Display pictures of weather instruments.

- D. Discuss the following:
 - 1. Today's weather.
 - 2. Weather forecasts from newspapers, radio, television, and other sources.
 - 3. The effects of weather.
- E. Suggest that pupils tell about the books that they have read about the weather.
- F. Find out what pupils think would be true about the causes of winds, clouds, rain, snow, hail, sleet, dew, fog, and hailstones.
- G. Suggest that pupils who have visited a weather station report on their experiences.
- H. Make note of misconceptions about the weather.

VI. Procedure

A. Launch

- Arouse enthusiasm by building on pupils' experiences.
 - a. See V. Introductory Activities.
 - b. Note misconceptions.

B. Organize

- 1. Provide time for pupils to browse among displays.
- 2. Determine:
 - a. What we want to know.
 - b. Where we find the answers.
 - c. How we get the facts.
 - d. What problems are involved.
 - e. Which problems are most important.
 - f. What our needs for groups or committees are.
 - g. How we shall build our vocabulary.

C. Learn (Class and Group Activities)

- 1. Use the following reference as a base for the study:
Schneider, Herman and Nina. *Science in Your Life*. Boston: D. C. Heath and Company, 1964, Unit III, pp. 49-76. (Pages listed below refer to this text.)
- 2. Discuss the pictures on pages 48-49. Ask the children to point out the things in the pictures which indicate types of weather.
- 3. Have the class read page 49. Help them to determine which of the phrases used to describe the different kinds of weather best answers the question, "What kind of weather are you having right now?"
- 4. Compare weather reports in different places. Are they the same?
- 5. Have the children go outdoors and feel with their hands how much warmer the land is in the sun than in the shade.
- 6. Let the children experiment with a bright light and different objects to see that light may be reflected, absorbed, or in some cases, may pass right through a material. Let the children feel the objects before and after the bright light has been applied.
- 7. Let the children, working in small groups, try the experiment on page 52 (with the globe and light) to see how day and night follow each other. After the experiment with the globe, ask the children to voice their opinions on the common saying, "The sun rises and the sun sets."
- 8. Let someone draw a mark around the area where the sun shines on the chalkboard, floor, and window sill. Every half hour, mark the new outline. Notice how the spot of sunlight has moved. Discuss whether it was the

earth or the sun that moved.

9. Plan a series of observations over a period of a week. Have individuals note the temperature at the beginning of the school day, right after noon when the sun is high overhead, and again at the end of the school day. Establish that the earth does warm up in the sunlight and cool off during the night.
10. A bright, sunny day in winter is not as warm as a bright, sunny day in summer. It is the same sun shining. What makes the difference? Do the experiment on page 53, "How does time in the sunlight make a difference?"
11. Ask questions about the pictures on page 54 to point out that the sun rises and sets in different locations and at different times.
12. Do the experiment on page 55 to help pupils understand why the land is not heated as much on a sunny day when clouds block off some of the sunlight.
13. Do the experiment on page 57 to see if a dish of water or a dish of soil warms faster. Be sure to put the thermometer just beneath the surface of the soil. It will take a long time for the heat to travel to the bottom of the dish of soil.
14. Do the experiment on page 58 to see if a dish of water or a dish of soil cools faster.
15. Have children experiment, as suggested in the experiment on page 60, to find out where winds are blowing and in what direction they are moving. Have them account for the winds in terms of colder, heavier air moving in and pushing up warmer, lighter air.
16. Place the following wind chart on the bulletin board:

Kind of Wind	What It Does
Breeze	Moves leaves on trees
Light Wind	Moves small branches
Fresh Wind	Blows flags and wind socks straight out
Strong Wind	Sways trees back and forth
Gale	Breaks branches, knocks down signs
Hurricane	Uproots trees, damages buildings

After discussing the facts in the chart, the children may want to copy it into their notebooks for future reference.

17. List the words rain, fog, snow, mist, clouds, hail, sleet, frost, and dew on the board. Have the children find out just what these words mean so that they may use them in their discussions to express precisely what they wish to say.
18. Do the experiment on page 64 to find out where water goes when things dry.
19. Do the experiment on page 66 to find out what happens when water vapor is cooled.
20. Plan and do a few experiments to see what factors make water evaporate faster.
 - a. Place two wet spots on the chalkboard and fan one to see that moving air evaporates water faster.
 - b. Place wet spots on a cold dish and on a warm dish to see if temperature affects evaporation.
21. See if moisture in the air slows the rate of evaporation. Put two wet spots on the board and then hold a shoe box with a wet towel in the bottom of it over one of the spots and a dry shoe box over the other spot.

22. Discuss with the children how dew is formed and have them perform the experiment on page 67, in which dew is formed on a jar of ice water.
23. Discuss the kinds of clouds that the pupils have observed. List the terms used in their descriptions. Perform the cloud-making experiment on page 68.
24. Suggest that the class keep a record of the kinds of clouds which they see in one week's time. Tell the pupils that they should look for the following things each time they observe clouds:
 - a. What was the weather like when those clouds were seen?
 - b. Were there quick changes in the kinds of clouds?
 - c. Did the weather change too?
 - d. How did the clouds move—quickly or slowly?
 - e. Were they high in the sky or low near the ground?
25. Make frost by adding salt to a can of crushed ice. The salt melts the ice. As the ice melts, it cools the can below the freezing temperature. Frost forms on the outside of the cold can.
26. Discuss with the children ways different kinds of precipitation are formed.
27. Ask the children how advance notice of weather conditions is helpful to us.
28. Things to do
 - a. Keep a class weather chart. Show weather conditions which include the following: outdoor temperature, sky condition, rain or snow, wind direction, and wind speed.
 - b. Keep a record of the weather predictions from the newspaper, radio, or television for a week. Compare the predictions with the class weather chart. Is the weatherman always right?
 - c. Go on a trip to a nearby stream, river, pond, or some other body of water. Take a thermometer. Keep a record of the temperature at different places along the way. Observe the size, shape, color, and movement of clouds. Compare the temperature of the water with the soil nearby. Note the speed of moving air along the way.
 - d. Using cotton, make a three-dimensional mural of the different kinds of clouds.
 - e. Make a weather station and observe, record, and predict the weather.
 - f. Collect pictures showing different kinds of weather. Tell how people and animals change the things they do when the weather changes.
 - g. Plan a visit to a weather station to learn about weather forecasting, to increase interest in scientific procedures, and to increase appreciation for the work of scientists.
 - h. Explain what causes the various air currents in the home—in the kitchen, near open windows, near air ducts, and elsewhere.
 - i. Try to find a toy that operates by use of air pressure and explain its operation.
 - j. Look for places in the indoor environment where water evaporates and condenses. Explain the conditions that are responsible. Explain how these conditions are similar to those outside that cause precipitation.
 - k. Select some weather "sayings" and try to test their accuracy by observation.
29. Correlation (Language Arts)
 - a. Use a variety of source materials.
 - b. Read to find answers to questions, to get additional information, and to verify conclusions.
 - c. Prepare outlines, summaries, and reports.

- d. Write letters to agencies for materials and information.
 - e. Keep notebooks.
 - f. Spell words related to weather.
 - g. Improve communication skills through oral reports, discussion, etc.
30. Correlation (Social Studies)
- a. Find out what the weather is like in another land. Compare it with the weather in our locality. What makes the difference or similarity?
 - b. Locate places on maps that have unusual weather conditions.
 - c. Study the effects of the weather on ways of living around the world.
 - d. Obtain some weather maps. How do they differ from other maps? What can be learned from them?
31. Correlation (Arithmetic)
- a. Read and record temperatures.
 - b. Record information on a weather chart.
 - c. Measure rainfall.
 - d. Compute the average rainfall and temperature.
 - e. Graph temperatures.
 - f. Measure time and materials accurately as needed in experiments.
32. Correlation (Health)
- a. Develop concepts about safety and weather, the effects of weather on work and play, weather and foods, and clothing and weather.
 - b. Gather information on the relationships between climate and health.
33. Correlation (Music)
- a. Learn songs related to the weather.
 - b. Select songs from:
Mursell, Tipton, Landeck, Nordholm, Freeburg, and Watson. *Music Near and Far, Book Four*. Chicago: Silver Burdett Company, 1956.
(Page references below refer to this text.)
"Growing Power from the Sun," p. 9
"The Rain Has Stopped," p. 16
"Long Summer Day," pp. 18-19
"Blow Away the Morning Dew," p. 20
"Weather Signs," p. 94
"Blow, Ye Winds," p. 100
 - c. Listen to records
"Winter Wind," *Etude Opus 25, No. 11*—Chopin
 - d. Create a dance. Use the movements of snowflakes as a theme.
 - e. Write songs about the weather.
34. Correlation (Art)
- a. Make drawings and sketches of weather concepts.
 - b. Use the following suggested titles and others for painting:
"The Kind of Day It Is"
"The Weather Station"
"A Bad Storm"
"The First Snow"
"Walking in the Rain"
"A Beautiful Day"
"Our Beautiful Sky Changes Color"
 - c. Design weather instruments.
 - d. Study these paintings:
"Fog Warning"—Homer
"Winter in Maine"—Kent
 - e. Construct mobiles.

VII. Evaluation

A. Daily Appraisal

1. What have we accomplished today?
2. How well have we done our work?
3. Are we improving?
4. How and what do we need to improve?

B. Judge Pupil Progress

1. Choice of books and written materials.
2. Quality of collections, drawings, or writings.
3. Change in attitudes toward each other.
4. Growth of ability in critical thinking.

C. Content

1. Did the subject matter open doors for the children?
2. Could the children state the problem?
3. Did the children arrive at conclusions themselves?
4. Did the children understand the concepts?

D. Summary and Testing Exercises

1. Teacher-made tests.
2. Tests (*Science in Your Life*, Teachers Edition, pp. 297-298).

VIII. Instructional Materials

A. Books

1. Blough, Glenn O., Julius Schwartz, and Albert J. Huggett. *Elementary-School Science and How to Teach It*, Revised Edition. New York: The Dryden Press, Inc., 1958, pp. 187-230
2. Craig, Gerald S. *Science for the Elementary-School Teacher*, New Edition. Boston: Ginn and Co., 1958, pp. 392-460
3. Fenton, Carroll Lane and Mildred. *Our Changing Weather*. New York: Doubleday and Co., Inc., 1954
4. Feravolo, Rocco V. *Weather Experiments*. Champaign, Illinois: Garrard Publishing Co., 1963
5. Friskey, Margaret. *The True Book of Air Around Us*. Chicago: Children's Press, 1953
6. Gaer, Joseph. *Everybody's Weather*. Philadelphia: J. B. Lippincott Co., 1944
7. Gallant, Roy A. *Exploring the Weather*. Garden City, New York: Garden City Books, 1957
8. Gibson, Gertrude Hevener. *About Our Weather*. Chicago: Melmont Publishers, Inc., 1961
9. Larrick, Nancy. *Junior Science Book of Rain, Hail, Sleet, and Snow*. Champaign, Illinois: Garrard Publishing Co., 1961
10. Meyer, Jerome S. *Picture Book of Weather*. New York: Lothrop, Lee and Shepard Co., Inc., 1948

11. Parker, Bertha Morris. *The Golden Book of Science for Boys and Girls*, Revised Edition. New York: Golden Press, 1963
12. Pondendorf, Ila. *Weather Experiments*. Chicago: Children's Press, 1961
13. Schneider, Herman and Nina. *Let's Find Out*. New York: William R. Scott, Inc., 1956
14. Tarnehill, Ivan Ray. *All About the Weather*. New York: Random House, Inc., 1953
15. Waller, Leslie. *A Book to Begin on Weather*. New York: Holt, Rinehart and Winston, 1959
16. Zim, Herbert S. *Lightning and Thunder*. New York: William Morrow and Co., Inc., 1952

B. Films

1. "How Weather Helps Us," 11 minutes, black and white, Coronet Instructional Films, 1957
2. "Air and What It Does," 11 minutes, black and white, Encyclopedia Britannica Films, 1962
3. "How Weather Is Forecast," 11 minutes, black and white, Coronet Instructional Films, 1958
4. "Thermometers and How They Work," 10 minutes, color, Encyclopedia Britannica Films, 1963
5. "Weather: Why It Changes," 11 minutes, black and white, Coronet Instructional Films, 1962
6. "What Makes Day and Night," 8 minutes, black and white, Young America Films, 1947
7. "Wind and What It Does," 11 minutes, black and white, Encyclopedia Britannica Films, 1963

C. Filmstrips

1. "Weather," color, Young America Films
2. "How Heat Causes Expansion," color, Jam Handy
3. "The Sun, Weather Maker," color, Curriculum Films, Inc.
4. "Water in Weather," color, Curriculum Films, Inc.
5. "The Weather Bureau," color, Curriculum Films, Inc.

Using all of the resources available to you, develop a plan for the preparation of units to be used in the science instructional program. Devise a long-range plan which includes not only development but also regular evaluation and revision of units. Insert a copy of this plan in the back of this publication in the manner suggested on page 196.



ACTIVITIES

Meaningful activities in an elementary school science program serve a number of purposes. They promote active learning, broader participation, and greater interest on the part of the students; assure better adaptation of curriculum to varied student abilities; and afford experience in scientific procedures, methods, and techniques.

More specifically, appropriate activities offer opportunity for children —

To learn science by becoming involved in the very kind of work which scientists engage in.

To related the study of science with other manipulative and learning skills.

To perceive the relationship of science to the world around us.

By utilizing a variety of approaches and procedures, activities can be adapted to a wide range of student abilities.

To be meaningful and effective, activities should be —

Carefully integrated into the total science instructional program.

Assigned to the appropriate grade level in the science instructional sequence.

Performed by the children.

Teacher demonstrations may be used to provide variety in teaching technique, to compensate for a lack of equipment, or to avoid the possibility of danger to the children. However, when pupil-performed experiments are possible, teacher demonstrations should not be considered an acceptable substitute.

The following activities relate to topics which are most likely to be explored in an elementary school science program. After a sequence has been developed, a careful study should be made of the basic understandings and the activities which have been designed to assist in the teaching of these understandings. In the color block beside each activity, write in the grade or grades at which it is felt that the activity should be used. An activity may be assigned for use in more than one grade, provided that the repetition serves some useful purpose.

Notes should be made in the margins concerning the use of the activities, with cross references to other activities which support the basic understandings, and references to sources of additional activities which are considered useful.

Each activity is numbered. The following index provides a key to the activities related to particular areas of science.

INDEX TO SCIENCE ACTIVITIES	
Topics	Activity Numbers
I. Introduction to Science	1- 16
II. Living Things	17-130
A. Our Bodies	17- 42
B. Animals	43- 87
C. Plants	88-130
III. Matter and Energy	131-334
A. Matter	131-147
B. Energy	148-153
C. Atomic Energy	154-160
D. Chemical Energy	161-186
E. Heat Energy	187-209
F. Wave Energy	210-256
G. Mechanical Energy	257-295
H. Electrical Energy	296-334
IV. Earth and Space	335-445
A. Earth	335-370
B. Earth's Atmosphere	371-408
C. Space	409-445

I. INTRODUCTION TO SCIENCE

1. Almost everything around us is related to science.

ACTIVITY

MATERIALS: pencil, paper

Have the children list all of the things which they see during a particular day that scientists study and learn about. The following day, compare and discuss lists.

2. There are many different types of scientists who do many different kinds of work.

ACTIVITY A

MATERIALS: books about science

Have the children look through as many books about science as they can find and make a list of the things which these books are about.

ACTIVITY B

If there is a university, college, industry, or research center near the school, arrange to visit it in order to have the children see scientists, the equipment they use, and the work they do.

3. Scientists are men and women with many interests but with a particular interest in science.

ACTIVITY

Invite a scientist from the community to come to the classroom to talk to the children and answer questions about science and scientists.

4. Scientists learn through observation and experimentation.

ACTIVITY A

MATERIALS: candles, matches, ruler, quart jar, gallon jar

Examine an unlighted candle carefully. Using any means available, learn as much as possible about the candle. Make a list of these observations. Included can be such things as length, diameter, color, material make-up, etc.

Light the candle. Again, through experimentation, measurement, and observation, record as many facts about the candle as possible. There is no limit to the kinds of things that can be explored. What is the flame like? How long will it burn when covered with a quart jar? Is there any relationship between the last two questions? How close can you hold your hand above the flame? Keep asking questions and finding a way to answer them.

Compare observations about the candle after you put it out to the observations which were made before lighting it.

ACTIVITY B

MATERIALS: small box, variety of small objects, magnet

In order to provide children with an opportunity for careful observation and experimentation, obtain a box about the size of a cigar box. Place several objects of different sizes, shapes, materials, and possibly one with an odor in the box. Seal it shut. Ask the children to describe the box in as much detail as possible. This will require looking at it, feeling it, lifting it, and even smelling it. In order to determine the contents of the box

Introduction to Science

without opening it, the children will have to devise numerous experiments and carry them out. For example, a round object will roll in all directions, a cylindrical object will roll in one direction but when tilted at a right angle it will not roll, and an object with a flat side will slide. When the box is shaken, metal and glass objects will tinkle upon striking one another. A magnet will hold certain metal objects in a position from which they will fall or slide when the magnet is removed. And so, through a variety of such experiments, the contents of the box can be identified.

5. Scientists sometimes find it helpful to approach a problem in organized stages.

ACTIVITY

MATERIALS: flashlight

One of many procedures for approaching a scientific problem is to follow steps such as the following:

- Define the problem
- Gather information
- Form a hypothesis
- Test the hypothesis
- Draw a conclusion
- Test the conclusion

Illustrate the use of these steps by doing something to a flashlight to make it inoperable. This can be accomplished by unscrewing the light bulb, turning the cells around, putting in burned out cells, or some other procedure. Have the children follow the six steps outlined above to determine what is wrong with the flashlight.

6. Scientists search for facts and are suspicious of superstitions and opinions.

ACTIVITY A

MATERIALS: advertisements

Examine several advertisements. Discuss the basis for statements and claims which are made for the product. Separate the facts from catch phrases and opinions.

ACTIVITY B

MATERIALS: horoscopes, superstitions and common "sayings"

Examine superstitions, common sayings, and predictions of the future. How many of them seem to be based on some definite evidence? Which ones should be believed and which ignored?

7. A career as a scientist requires ability and training.

ACTIVITY A

MATERIALS: letter paper

Have the children write to agencies and companies which employ scientists and request pamphlets on scientific career opportunities and the requirements for applying for such careers. Discuss the contents of these pamphlets and summarize the types of ability and training which are mentioned most often.

ACTIVITY B

Ask a high school science teacher or a school guidance counselor to visit the class and discuss the ability and training which is necessary to become a scientist.

Introduction to Science

8. Special apparatus has been designed for use in scientific investigations.

ACTIVITY

MATERIALS: scientific apparatus, paper, crayon, table

Assemble several pieces of scientific apparatus which are commonly used in science demonstrations and experiments. Label each with its proper name and prepare a display on a table. Question the children from time to time of what each piece of apparatus is. (See Appendix D for examples of apparatus.)

9. The study of science requires understanding many new words.

ACTIVITY

MATERIALS: notebook

Have each child keep a list of new words which he encounters in his study of science during the year along with their meanings. These words can be used by the teacher in vocabulary and spelling drill.

10. The study of science requires accurate measurements.

ACTIVITY

MATERIALS: measuring devices

Have the children explore their community and list all of the devices which they can find that are used in making measurements. When possible, bring some of these devices to the classroom. Discuss the ones which were seen and those which are available for examination. What types of measurements are made? How do these devices compare in accuracy of measurement?

11. Scientific information is distributed through special science publications.

ACTIVITY

MATERIALS: science journals and publications

Search the school library and any other libraries in the community for magazines and journals which deal exclusively with science. Examine them for information concerning the publisher and the type of articles which each one contains.

12. Scientists belong to professional societies along with other scientists who have similar interests.

ACTIVITY

Assign children in the class to interview scientists, engineers, doctors, dentists, and other individuals in the community who belong to scientific societies. Learn what these societies are and what the main goals and purposes of each are. Have each child report his findings to the class.

13. Scientific investigation helps raise the standard of living within a country.

ACTIVITY A

Determine the number of children who have at least one parent employed in an occupation or profession which either deals with or results from recent scientific advances. Included could be employment in synthetic fiber mills, electronic industries, medical centers, plastic industries, etc.

ACTIVITY B

Have the children look around them and identify everything which is product of scientific discovery and advancement. Discuss the effects which these discoveries have upon the way in which we live.

Introduction to Science

14. Science has developed gradually over the ages.

ACTIVITY

MATERIALS: references

Have the children search the library for pictures in books which illustrate stages in man's use of machines, communication devices, transportation, etc. Discuss the gradual development in science and technology.

15. Many men and women have contributed to our present knowledge of science.

ACTIVITY

MATERIALS: chalkboard, references

Have each child consult references on a different scientist and be prepared to tell briefly when the scientist lived and the general field of his or her work. List the names on the chalkboard as they are mentioned. After all are listed, group them according to the field in which they worked and list them in chronological order within groups.

16. Pure science is the study of the principles of science. Applied science is the development of uses of these principles.

ACTIVITY

MATERIALS: two bar magnets, electric motor

Demonstrate that unlike poles of a magnet attract and like poles repel. This is a scientific principle. Turn on an electric motor (an appliance such as an electric mixer or electric drill is suitable). The motor is an application of the attraction and repulsion of magnetic poles. Have the children think of other such examples.

II. LIVING THINGS

A. Our Bodies

17. The body has many parts that work together to keep it healthy.

ACTIVITY A

MATERIALS: animal parts

Obtain from farms, butcher shops, or the dinner table things that can be examined to help the children better understand the parts and the structure of the body. Bones, hearts, livers, and a wide variety of other animal parts are readily available. Examine and discuss them.

ACTIVITY B

MATERIALS: paper, crayons, bulletin board

List the names of the parts of the body which are visible on the outside of the body. List for each some of the things which that part does for the body. Illustrate the lists with drawings of the body parts and drawings of what these parts do to help the body. Arrange the list and drawings on a bulletin board.

ACTIVITY C

MATERIALS: broiler chicken

Examine the joints and muscles of a broiler chicken. Compare them with those of a human being.

ACTIVITY D

MATERIALS: paper, pencil

List the names of some of the internal parts of the body. For each, list some of the things which that part does for the body.

18. We become aware of our surroundings through our five senses.

ACTIVITY A

Our senses warn us of danger and protect us from injury. Have the children discuss ways in which their senses have helped to keep them from being hurt.

ACTIVITY B

(Smell)

MATERIALS: blindfold, variety of materials with odors

Blindfold a child and have him identify a variety of materials such as food, plants, perfumes, etc., by their odors.

ACTIVITY C

(Touch)

MATERIALS: sharp pencil

In order to have the children gain a better understanding of the role which nerve endings play in sensing pressure, heat, cold, and pain, have each child mark off an area on the back of the first joint of his middle finger. Using a sharpened pencil, have him carefully press the point firmly against the skin at many places within the area. Have him experiment to determine the places within the marked area which produce each of the sensations mentioned.

CAUTION: Do not attempt this activity if you feel that there is any chance that the children might injure themselves while doing it.

Our Bodies

ACTIVITY D (Hearing)

If the school nurse has access to equipment for testing hearing, ask her to bring it to school and demonstrate it to the children. If possible, have each child tested.

ACTIVITY E (Taste)

MATERIALS: 4 water glasses, water, toothpicks, salt, sugar, lemon, alum (used in making pickles), paper, pencil

Different parts of the tongue are sensitive to different tastes. To determine which parts are sensitive to each taste, prepare solutions of sugar (sweet), lemon (sour), salt (salty), and alum (bitter). Using toothpicks which can be disposed of after use, apply the different solutions to different parts of the tongue. Prepare a drawing of the tongue and indicate the parts which are most sensitive to each taste.

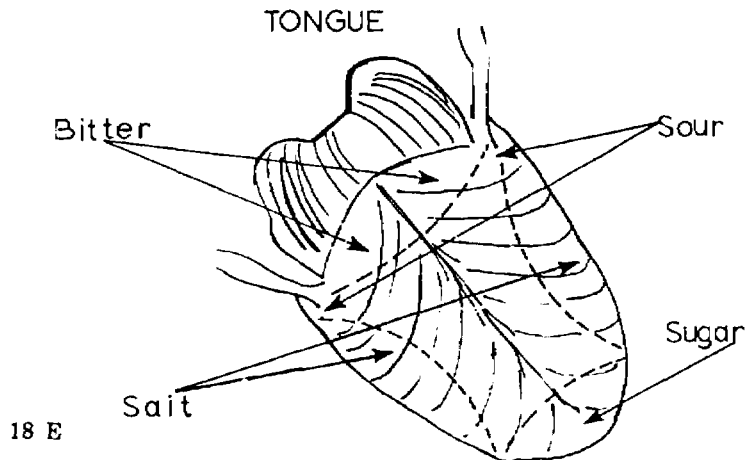

ACTIVITY F

MATERIALS: blindfold, onion, apple

Blindfold a child and have him hold his nose. Have him taste a piece of onion and a piece of apple. Can he distinguish between them?

19. Our bodies exhale carbon dioxide. (respiratory system)

ACTIVITY

MATERIALS: limewater, drinking glass, soda straw

When limewater reacts with carbon dioxide, a white substance is formed. To demonstrate one way in which carbon dioxide gets into the air, half fill a drinking glass with fresh limewater. Exhale through a straw immersed in the limewater, bubbling your breath through the limewater. Observe and explain any changes.

LIVING THINGS

20. Our muscles enable us to move. (muscular system)

ACTIVITY A

MATERIALS: fresh chicken foot, tweezers

Secure a fresh chicken foot from a meat market. Locate the tendons where the cut was made and pull them with tweezers. Observe how they cause movement of the foot.

ACTIVITY B

Sit at a table and place your right elbow on the table. Move your right hand up and down while feeling the upper part of your arm with your left hand. Notice how the muscles move with the movement of your hand. Discuss. Locate other muscles in your body.

21. The pumping heart circulates blood throughout the body. (circulatory system)

ACTIVITY A

MATERIALS: inexpensive stethoscope

Using a stethoscope, allow the children to listen to the sounds made by their hearts as they beat and pump blood throughout the body.

ACTIVITY B

Teach the children to count their pulse rate by placing their fingers on their wrists. Have them count their pulse rates before and after exercise. Discuss why the heart speeds up during exercise in order to provide food and oxygen to the body and to carry off waste materials.

22. Food is digested in order to convert it into a form that is useful to the body. (digestive system)

ACTIVITY

MATERIALS: fish, scalpel or sharp scissors, picture or diagram of human digestive tract, references

Catch a fish or obtain one from a meat market. Cut it open and examine the digestive tract. Compare this with a picture of the human digestive tract. Gather information on and discuss what happens to food at each location in the digestive tract.

23. Bones provide support for the body. (skeletal system)

ACTIVITY

MATERIALS: rag doll

Demonstrate the lack of support in a rag doll and how it is possible to bend its arms and legs in any direction. Contrast this flexibility with our bodies. What is it within our bodies that makes them more rigid? How would it affect us if our bodies were like that of a rag doll?

24. The brain is the center of the nervous system. (nervous system)

ACTIVITY

MATERIALS: poster paper, crayons, references

Draw the outline of a man. Within this outline, draw the brain and the spinal cord. Using references, gain as much background as you can for filling in a network of the more important nerves leading from the eyes, ears, arms, legs, etc.

25. Hormones are chemicals which help to control our bodies. (endocrine system)

ACTIVITY

MATERIALS: references

Gather information about hormones. Prepare a chart on the hormones

Our Bodies

that are secreted in the body, what control they have on the body, and what happens if too much or too little of a hormone is secreted.

26. **Our skin serves to protect the body, control body temperature, and dispose of body waste. (integumentary system)**

ACTIVITY

MATERIALS: references

Have each child examine his skin carefully and list those characteristics which describe it. Seek information about, and discuss the ways in which the skin acts in body protection, temperature control, and waste disposal.

27. **Cleanliness is important in keeping the body healthy.**

ACTIVITY

MATERIALS: paper, pencil

Have the children discuss and suggest habits of cleanliness which are important to keeping the body healthy. These should include such things as bathing, brushing teeth, washing hands, etc. After several important habits have been discussed, have each child prepare a chart on which he can check off whether he is performing these important tasks.

28. **A healthy body needs regular exercise.**

ACTIVITY

Consult the local school physical education supervisor for a suggested program of exercises to be begun and carried out during the school year.

29. **A healthy body needs rest and sleep.**

ACTIVITY A

Have the children discuss how they felt on a night when they stayed up particularly late or an occasion when they had to go for a particularly long period of time without sleep. How did lack of sleep affect them?

ACTIVITY B

MATERIALS: paper, pencil

Have each child keep a record of the number of hours he sleeps each night. Compare these records with normal requirements. Calculate the average hours of sleep per day for each child and the average for the entire class. Compare these averages with normal requirements.

30. **Proper care of our bodies can help prevent disease.**

ACTIVITY A

Discuss with the children the importance of proper clothing, adequate nourishment, regular toilet habits, brushing teeth, bathing regularly, and other personal habits that prevent disease.

ACTIVITY B

MATERIALS: letter paper, envelopes, stamps, pencils

Have the children write letters to various local agencies such as the public health office, heart association, tuberculosis association, Red Cross, etc., for information on the causes and methods of preventing disease.

LIVING THINGS

31. Good public health habits help control the spread of disease.

ACTIVITY

MATERIALS: paper, crayons

Invite the school nurse to discuss with the children important public health habits which they can develop to assist in cutting down disease. Have each child prepare a poster which illustrates one of these habits or rules. Display the posters in various parts of the school.

32. Communicable diseases are caused by microorganisms.

ACTIVITY

MATERIALS: 3 apples (one partially rotten), 2 needles, match

Sterilize a needle in a flame. After it cools, pierce the rotten spot on the damaged apple. Use the contaminated needle to pierce the skin of one of the other apples in several places. Tag the apple which has been pierced with the contaminated needle and discard the needle and rotten apple. Sterilize the other needle in a flame and use it to puncture the skin of the third apple in several places. All other factors being equal, the apple which was punctured with the contaminated needle will begin to decay before the apple punctured with the sterile needle. Relate this experiment to the spread of disease by germs.

33. Antiseptics can be used to control germs.

ACTIVITY

MATERIALS: beans, test tubes, cotton, a variety of antiseptics (iodine, alcohol, etc.)

Microorganisms which cause decay are essentially the same as germs which cause disease. To determine how effective antiseptics are in controlling germs, place about five beans in each of several test tubes. Cover the beans with water. To each test tube add 10 ml. of antiseptic using a different antiseptic for each test tube. Maintain one test tube without antiseptic as a control. Plug the tops of the test tubes loosely with cotton and store in a dark, warm place. Observe the tubes periodically to detect decay. Which beans decay first? Which antiseptics seem most effective?

34. Diseases cause changes in the body which can be recognized as symptoms of diseases.

ACTIVITY A

Have the children describe the symptoms of diseases which they have had, such as measles, mumps, chicken pox, etc.

ACTIVITY B

Contact the local public health service and such agencies as the tuberculosis society, heart association, and cancer society to gain pamphlets, speakers, films, and information on symptoms of various diseases.

35. Diseases affect all aspects of our society.

ACTIVITY

MATERIALS: statistical reports on diseases

Obtain information from newspapers, magazines, and health departments on the disease rate at the local, state, and national levels. Gain permission to examine your school's contagion reports. How many days of school absences are due to illness each year? How much do industries lose because of workers' illnesses? What are some of the other effects of disease on our society?

Our Bodies

36. Special precautions are taken to control communicable diseases.

ACTIVITY

Invite a public health worker to discuss with the class what his agency does to reduce the spread of communicable diseases.

37. Some diseases can be prevented by immunization.

ACTIVITY A

MATERIALS: personal health records, references

Have each student bring to school a list of diseases for which he has received some sort of immunization treatment. Discuss the methods by which immunization treatments are administered. Determine the diseases for which all of the children have been immunized. Explore references to learn more about the diseases for which the children have been treated and discuss why this treatment is so important to them.

ACTIVITY B

MATERIALS: references

Assign reports to individual students on scientists, such as Jenner, Pasteur, and Salk, who have contributed to our knowledge of immunization against diseases.

38. Sanitary practices reduce the spread of disease.

ACTIVITY

Invite the school janitor and a cafeteria worker to describe for the class methods which they use to prevent the spread of disease and to insure that the school receives a high sanitation rating.

39. Our bodies need a variety of foods.

ACTIVITY A

MATERIALS: food packages

Examine various food packages and record what vitamins and minerals are present in each. Look also for the presence of fats, carbohydrates and proteins. Empty packages can be brought to school and displayed.

ACTIVITY B

MATERIALS: magazines, scissors, paper, references, bulletin board

Vitamins are important to body health. Consult references to determine what the various vitamins are and what foods contain them. Prepare a section of a bulletin board for each vitamin, and fill in the section with pictures from magazines of foods which contain the vitamin.

ACTIVITY C

MATERIALS: magazines, scissors, paper, references, bulletin board

Carbohydrates, fats, and proteins are three important types of food. Consult references to determine what foods belong in each group. Cut pictures of examples of each from old magazines and prepare a bulletin board about them.

ACTIVITY D

MATERIALS: bulletin board, scissors, paper, string, references

Cut out the figure of a child and mount it on a bulletin board. Surround

LIVING THINGS

the child with tabs of paper on which are written the names of various vitamins and minerals. Run a string from the name of the vitamin or mineral to the part or parts of the body to which it is important.

40. Dairy foods, meat group foods, vegetables and fruits, and breads and cereals compose the four categories of vital foods.

ACTIVITY A

MATERIALS: references, poster paper, crayons

Divide the class into four committees. Have each committee prepare a poster on one of the four basic food groups. Include on the poster what the group is, what foods are represented, and what nutrients these foods contain.

ACTIVITY B

MATERIALS: poster paper, references

List as many things as you can think of which our bodies do. Under each, list the food group or groups which are important to the body in accomplishing this function.

41. Healthy bodies need a balanced diet.

ACTIVITY

MATERIALS: paper, pencil

Have each child prepare a chart with the days of the week down the side of the paper and the four basic food groups across the top. On this chart, have him check off the number of servings of each food group which he receives each day during the week. At the end of the week, compare with minimum requirements and discuss. The opportunity is available to identify children who are receiving an inadequate diet. Care should, of course, be taken to avoid embarrassing any of the children.

42. Good eating habits are important to good body nutrition.

ACTIVITY

MATERIALS: pencil, paper

During one day, have each child keep a record of what he eats, the approximate amount of each food, and the time of day at which it was eaten. Analyze these records to determine whether good eating habits were practiced. Consider all aspects of nutrition such as balanced diet, number of calories, between-meal snacks interfering with meals, etc.

B. Animals

- 43. Many different animals live around us.**

ACTIVITY

MATERIALS: pencil, paper

Have the children list all of the animals which they can find living around their homes and school. Include all mammals, birds, fish, insects, worms, and other animals; many may require some searching to find.

- 44. Animals vary in body structure to suit their particular habits and environment.**

ACTIVITY

MATERIALS: available animals, pictures of animals

Examine and compare a variety of animals. Discuss why certain body parts and characteristics are suitable for one animal but not another. For example, why are webbed feet good for a frog but not for a horse?

- 45. The habitat of an animal is the place where he is usually found.**

ACTIVITY

Observe undomesticated animals which live nearby. Small mammals, birds, fish, and insects provide good subjects. Describe the habitat in which each lives. Discuss reasons why the habitat of one animal might be completely unsuitable for another.

- 46. Some animals (herbivorous) eat plants, and some animals (carnivorous) eat other animals.**

ACTIVITY

MATERIALS: available animals, references

List those animals which live primarily on plants and those which depend mainly on other animals. Discuss the characteristics and body parts of various animals which are particularly suitable to their method of food getting.

- 47. Living things reproduce their own kind.**

ACTIVITY

MATERIALS: animal cage, male and female hamsters

Breed a pair of hamsters. Observe the female hamster carefully through pregnancy, birth, and care of her young.

- 48. Some animal young pass through stages during which they do not resemble their parents, whereas other animal young resemble their parents during all stages of development.**

ACTIVITY A

MATERIALS: references

Locate pictures of animals and their young. Display them in two groups: baby animals that resemble their parents and baby animals that do not resemble their parents.

ACTIVITY B

MATERIALS: jar, yeast, banana, fruit flies, paper towel, glass bottle, wad of cotton

Prepare a medium for keeping fruit flies by dipping a piece of ripe banana into a yeast suspension. This yeast suspension can be prepared by dissolving a quarter of a package of yeast in about a half cup of water.

LIVING THINGS

Remove the banana and put it, with a strip of paper towel, into a clean glass bottle.

Capture some fruit flies around soft grapes, bananas, or any other fermenting fruit. Put them in the bottle and seal it with a wad of cotton. Observe the various stages of development of the fruit fly and how the young pass through stages during which they do not resemble their parents. The eggs appear as white specks. Larvae look like white worms. Pupae are small, brown, and cigar-shaped. The adult is the familiar form.

49. Animals move in a variety of ways.

ACTIVITY

MATERIALS: available animals

Observe all available animals and notice how they move from one place to another. Some animals use more than one method. Observe, compare, and discuss.

50. Animals help man in many ways.

ACTIVITY A

MATERIALS: references

Locate books, either fiction or nonfiction, which contain stories about helpful animals. Numerous stories exist about dogs, horses, dolphins, etc.

ACTIVITY B

MATERIALS: animal products

Prepare a display of actual or pictured animal products. Foods, leather, ivory, fur, wool, and many other possibilities are available.

ACTIVITY C

MATERIALS: 2 potted plants, earthworms

Put two or three earthworms in the soil of one potted plant and none in the soil of another. Control the environment of both plants to make it as closely identical as possible. Over a long period of time, does the presence of earthworms have any effect upon plant growth?

51. Some animals cause costly damage.

ACTIVITY A

Explore the neighborhood for trees and plants which look diseased. Determine if any of these injuries were caused by insects or other animals.

ACTIVITY B

Invite a farmer or agricultural agent to come to the school and tell the children about insects and other animal pests which attack crops and farm animals. Discuss ways in which these pests are controlled.

ACTIVITY C

Invite an exterminator to visit the class to show the children how to identify termites and to display the types of damage which termites can do.

52. Animals vary in size and shape.

ACTIVITY A

MATERIALS: toy animals

Have the children bring toy animals to class. Use these as a basis for discussions of the actual structures and sizes of the animals represented.

Animals

ACTIVITY B

MATERIALS: clay

Make clay models of animals and display them. Print the name of each animal on a label.

ACTIVITY C

MATERIALS: books about animals

Using pictures of animals and animals which you have seen, list all the animals that you can think of. Arrange the list in order, starting with the largest and ending with the smallest. What is the tallest animal you can think of? What is the smallest? What is the heaviest animal you can think of? What is the lightest? Compare animals with regard to other characteristics which occur to you.

53. Animals vary in color.

ACTIVITY

MATERIALS: animal crackers

Have a party with animal crackers. All of the animal crackers are the same color. Discuss what color the real animal is which is represented by each cracker.

54. Animals behave in different ways.

ACTIVITY A

Have the children discuss their pets and compare the habits of different animals. Discuss and compare such animal activities as eating, sleeping, excretion, reproduction, play, etc.

ACTIVITY B

MATERIALS: observation ant nest, ant colony, references

Observe the behavior of ants in an observation ant nest. Try to explain the reasons for their actions. For example, what does it mean when ants touch each other when meeting? Locate references which will be of assistance.

55. Animals move in different ways.

ACTIVITY A

MATERIALS: records of music, phonograph

To music, have the children dramatize the movements of various animals.

ACTIVITY B

MATERIALS: goldfish, insects, other animals

Using animals that can be brought into the classroom, observe carefully how each one moves.

ACTIVITY C

MATERIALS: magazines, books about animals

Collect and display pictures of animals moving. Find examples of animals running, swimming, walking, galloping, flying, crawling, hopping, jumping, etc.

56. Animals grow.

ACTIVITY

MATERIALS: pet animal, cage

Obtain a young animal such as a rabbit or guinea pig which can be kept

LIVING THINGS

in the classroom. Keep a chart with a record of growth. Measure and weigh the animal regularly and record the growth on the chart. Perhaps the children would like to record their own growth and compare it with that of the animal.

57. **Some animals build special homes for themselves and their families.**

ACTIVITY

MATERIALS: bird nests

Collect abandoned bird nests. Try to identify the kind of bird which lived in each. Label and display.

58. **Different animals produce different calls and sounds.**

ACTIVITY

Have the children listen to different animals and learn to imitate their calls. Allow the children to imitate the calls for their classmates and have them guess what they believe the animal to be. Discuss whether they believe that animals communicate by these calls.

59. **Some animals bear living young.**

ACTIVITY A

MATERIALS: cage, male and female mice, rats, or hamsters

Obtain male and female mice, rats or hamsters and keep them in a cage in the classroom. Observe them carefully as the female becomes pregnant, as the young are born, and as the young are cared for.

ACTIVITY B

MATERIALS: aquarium, guppies

Observe guppies in an aquarium from day to day. The pregnancies of the females become quite obvious and, by following them closely, it may be possible to observe the young being born.

60. **Some animals are produced from eggs laid by their mothers.**

ACTIVITY A

MATERIALS: incubator, chicken egg

Obtain a simple incubator from a science supply house. Hatch a chicken egg in the incubator and care for the young chick as a pet.

ACTIVITY B

MATERIALS: aquarium, fish (egg layers)

Secure egg-laying fish from a pet shop. Keep them in your classroom aquarium and observe their life cycle.

61. **Classification is made on the basis of similarities and differences in characteristics.**

ACTIVITY A

Have the children analyze the similarities and differences between themselves and things around them. Anything can be used. A rock, a house, a plant, a rabbit, a hamster, a doll, or a statue are all suitable examples. Have them employ observation, measurement of size, measurement of weight, color, texture, use of reference materials, and critical thinking in their analysis. Such comparisons provide a basis for understanding classifications.

Animals

ACTIVITY B

To give the children practice in classification, have them divide themselves into two groups according to some characteristic. It may be according to sex, height, weight, color of hair, or anything they want. Then, have them subdivide each of the two groups into two more groups according to another characteristic. Continue the subdivisions as long as possible.

To show that this is not the only approach which can be used, have them start again with a different characteristic from the one that they began with before and repeat the procedure. Impress them with the idea that there are many ways to divide and classify. The best way is simply the way which is most useful to the classifier.

ACTIVITY C

Have the students list the ways in which they are the same and the ways in which they differ. In addition to obvious differences, have them search their imaginations for others such as differences in jumping ability, running speed, singing range, etc.

62. **Animals may be classified according to similar characteristics.**

ACTIVITY

MATERIALS: references

Locate as many pictures of different animals as possible. On the basis of these pictures, divide the animals into groups with animals with similar characteristics in a group. Discuss the reasons for your divisions.

63. **Animals may be classified as those which have backbones (vertebrates) and those which do not have backbones (invertebrates).**

ACTIVITY A

MATERIALS: chalkboard

Make a list of all of the animals that can be thought of. Go back over the list and indicate which ones have backbones and which do not. In so doing, you classify them into two groups. Which group appears to contain the larger number of animals?

ACTIVITY B

MATERIALS: variety of animals

Gather a variety of animals such as worms, insects, fish, snakes, caterpillars, etc. Examine each to determine whether it has a backbone. Assign each to its proper classification.

64. **Invertebrates are animals which do not have backbones.**

ACTIVITY

MATERIALS: references, representative invertebrates

Invertebrates can be classified into several groups according to their characteristics. Locate a listing of these groups and see if someone can bring to class an animal representing each group. Compare them. In what ways are they similar and in what ways are they different?

65. **Vertebrates are animals which have backbones.**

ACTIVITY A

MATERIALS: chicken backbones, fish, beef or pork backbones

Purchase a chicken backbone and other backbones at the grocery store.

LIVING THINGS

Remove the meat and examine the backbone. Perhaps you can compare this with the backbones of other animals such as a fish.

ACTIVITY B

MATERIALS: references, representative animals

Vertebrates are sometimes divided into such classifications as fishes, amphibians, reptiles, birds, and mammals. Have the children bring in pet animals which represent each of these groups. Compare them. In what ways are they the same? In what ways do they differ?

66. The smallest animals exist as single living cells.

ACTIVITY

MATERIALS: straw, jar, rain water, microscope, microscope slide, references

Soak some straw in rain water for several days. Put a drop of water on a microscope slide and examine it under a microscope for one-celled animals. Attempt to identify them by consulting references.

67. Animals need food, water, oxygen, and shelter.

ACTIVITY

Have the children observe as many animals as they can over a period of a few days. Have them list the things which they believe the animals must have in order to live. Compare and discuss the lists.

68. Animals need food and water.

ACTIVITY A

MATERIALS: bird feeder

Prepare a bird bath and a bird feeding station on the school grounds. Offer several different types of food including various seeds for the birds to eat. Record what they seem to like best.

ACTIVITY B

Have the children tell about the kinds of food which they feed their pets. List each type of animal and the types and amounts of food which each one eats. Discuss and compare the variety of needs among the different animals.

69. Animals obtain food from living things found around them.

ACTIVITY

Have the children observe the feeding habits of different animals in captivity, in the classroom or in the field. A toad eating an insect, a praying mantis eating an insect, a caterpillar eating a leaf, a fly eating sugar, or a spider capturing a fly are but a few which would be of interest to children. Discuss your observations in class.

70. Some baby animals need their parents to take care of them.

ACTIVITY

If a child's pet cat or dog has a litter, arrange to visit the child's home and observe the care which the mother gives her young.

CAUTION: Be certain that necessary precautions are taken to avoid bites and injuries.

Animals

71. **Animals which are kept for pets need regular care.**

ACTIVITY

Plan for a pet day on which each child is allowed to bring his pet to school. Have each child tell what he must do to care for his pet and what special care is required for baby animals when they are born.

72. **Different kinds of animals live in different places.**

ACTIVITY A

MATERIALS: references

Have the children explore their neighborhood and observe the homes of different types of animals. Even within a town, such animals as birds, ants, pet fish, wasps, and squirrels can be found. Consult reference books for description and pictures which provide information on homes in which animals live. Discuss these differences.

ACTIVITY B

MATERIALS: bird nests

To show that even different kinds of birds live in different types of bird nests, collect and display a variety of abandoned nests.

73. **Different animals have different kinds of coverings.**

ACTIVITY

MATERIALS: samples of animal coverings, pictures of animals

Discuss the variety of types of animal coverings. What differences are found among cats, fish, elephants, turtles, and birds? Have the children bring samples of body coverings such as fur, feathers, fish scales, snake skin, turtle shell, snail shell, clam shell, etc. Display these examples with pictures of other animals which have similar coverings.

74. **Some animals are protected by their coloration.**

ACTIVITY

MATERIALS: 100 toothpicks, colored paints

Paint fifty toothpicks green and fifty in other colors. When dry, throw them out on the grass within a restricted area. Without indicating the purpose of the activity, have the children pick up toothpicks for one minute and then stop. Count the number of green toothpicks collected and compare this number to the number collected of other colors. Just as the green toothpicks are hardest to find because they blend into the background, so also are animals protected by being the color of their backgrounds.

75. **Many animals have colors and markings which blend into their surroundings.**

ACTIVITY

Observe carefully birds, insects, and other undomesticated animals in your neighborhood. Notice them in the context of the surroundings in which they live. Discuss in class the manner in which various animals blend into their surroundings.

76. **Some animals sleep during the winter. This long sleep is called hibernation.**

ACTIVITY A

Assign a group of children to prepare and present a play about a bear hibernating during winter. Have them include preparations, hibernation, and activities of the bear when he awakens.

LIVING THINGS

ACTIVITY B

MATERIALS: references

Locate pictures of animals which sleep during the winter. Discuss why they hibernate and the places where they hibernate.

ACTIVITY C

MATERIALS: aquarium, sand, water, frog, ice

To observe preparations for hibernation, place a frog in a semiaquatic terrarium which contains sand and water. Surround the terrarium with ice and observe the frog carefully.

77. Some birds migrate when seasons change.

ACTIVITY

MATERIALS: bulletin board, large paper

Keep a monthly record of birds seen in the school yard during the year. From this record, determine which birds migrate, which birds stay in the area during the winter, which birds stay away the longest, which birds stay away for the shortest period of time, and any other information which can be gleaned from these observations.

78. Animals have ways to protect themselves.

ACTIVITY A

Working in groups of two, have the children prepare pantomimes of ways in which animals protect themselves. Have each group present its dramatization before the class and allow the other children to guess what the animal is and what it is doing.

ACTIVITY B

MATERIALS: references, large sheets of paper

Through observations of animals around them and available references, have the children list some of the general methods which animals employ for protection. These can include such factors as speed, strength, sharp claws, hard shells, protective coloration, undesirable odor, stingers, etc. Prepare a chart for each factor and list under each the animals which use that particular method of protection.

79. Animals give us food and other products.

ACTIVITY A

MATERIALS: large sheets of paper, pictures of animal products

List foods and other useful products that we get from animals. Illustrate the list with pictures that are available.

ACTIVITY B

MATERIALS: jar, cream

To illustrate how animal products are treated to produce useful food, make butter by shaking cream in a jar until it thickens.

80. Animals can be bred to produce desirable characteristics.

ACTIVITY A

MATERIALS: books about dogs

Locate information on dogs which have been developed through selective breeding to perform special tasks such as hunting, leading the blind, serving as guards, racing, etc.

Animals

ACTIVITY B

Invite an agricultural agent or a dairy farmer to tell the class about breeding methods which are presently being used to improve the quality of dairy herds.

81. Hybrids are the offspring of parents of two different species.

ACTIVITY

MATERIALS: references

A mule is a hybrid resulting from mating a horse and a donkey. Have the children search references for additional information about mules and the identities of other hybrids.

82. According to theories of evolution, living things undergo change over long periods of time.

ACTIVITY A

MATERIALS: references

In an encyclopedia or some other reference, locate pictures of the ancestors of modern horses and discuss the changes which have taken place. Also discuss how man is breeding horses to produce other changes.

ACTIVITY B

MATERIALS: pictures of extinct animals, references

Examine pictures of animals which have been extinct for many thousands of years. Discuss possible reasons for extinction. Consult references for additional information.

83. Many plants and animals are dependent upon one another for life.

ACTIVITY

MATERIALS: 2 large test tubes, stoppers to fit test tubes, elodea, tape, water snails

Fill two test tubes with aquarium water. Put a water snail into each tube. Add a healthy sprig of elodea to one of the test tubes. Stopper both test tubes tightly, seal the stoppers with tape, and place them in a warm, well-lighted location away from direct sunlight. Observe the contents of the test tubes periodically. All other factors being equal, the snail sealed with the elodea will live longer than the snail that is sealed by himself due to the fact that in the former case there is an exchange of oxygen and carbon dioxide.

84. Different living things are dependent upon one another.

ACTIVITY

Select an area, preferably a wooded or overgrown lot, near the school. Examine it carefully and list all of the living things which can be found in the area. Analyze the list to determine which living things in the area are dependent on others. For example, plants might need insects for pollination. Birds need seeds and insects for food. Rabbits need plants for food and protection. How many such examples can you think of?

85. Man has sometimes interfered with living things and upset the balance of nature.

ACTIVITY

MATERIALS: references

Have the children report on what resulted from the introduction of rabbits into Australia, English sparrows into the United States, Japanese beetles into the United States, and other examples in which the balance of nature was disturbed. Discuss their findings.

LIVING THINGS

86. Man is attempting to restore a balance of nature to some areas where he has disturbed it.

ACTIVITY

Invite an agricultural agent or a forest ranger to describe to the class an area in which man has destroyed the balance of nature and has therefore caused natural disaster. Have him describe methods which are being utilized to restore some of these areas.

87. Programs of conservation are needed to protect our natural resources.

ACTIVITY A

MATERIALS: garden tool

Examine the school grounds for evidence of soil erosion or some other waste of natural resources. If a small conservation project such as growing grass can be developed, arrange with the school principal for the class to carry it out.

ACTIVITY B

An important part of conservation is conserving natural beauty. Many school yards are marred by unsightly litter. Arrange with the principal to establish a schedule for classes to take turns picking up scraps of paper and other debris from the school grounds.

ACTIVITY C

Invite a wildlife and game protector to the school to describe methods which are used to help insure the conservation of wildlife.

C. Plants

88. Plant life exists in many different varieties.

ACTIVITY

MATERIALS: books on plants

Take a walk in a nearby field or woods. Identify as many trees and plants as possible. Take books and field manuals to assist you. Point out the features such as flowers, leaves, bark, etc., which are most commonly used in identification.

89. Leaves vary in their characteristics.

ACTIVITY

MATERIALS: variety of leaves

Examine leaf specimens from a variety of trees and other plants. Note the differences in size, edge, shape, color, texture, stem arrangement, etc.

90. Various species of plants are adapted to live in different environments.

ACTIVITY

MATERIALS: ferns, mosses, cacti, 3 terrariums, references

Collect or purchase samples of ferns, mosses, and cacti. In what type of environment does each of these plants live? Prepare a terrarium for each with the kind of habitat to which it is adapted. Vary the habitats by varying light, temperature, and moisture. Notice that the plants will die if their environments are altered too drastically. (See Appendix A on how to prepare a terrarium.)

91. Some plants grow from seeds.

ACTIVITY

MATERIALS: variety of seeds, book on seeds

Have the children collect as many examples of seeds as they can find. If possible, have them identify the plant from which each seed came. Fruits, vegetables, nuts, flowers, weeds, and many other sources are readily available to them. Label and display the collection.

92. Plants are useful in many ways.

ACTIVITY A

MATERIALS: plant products, pencil, paper, old magazines, scissors, paste

Over a period of a day or two, have each child list every way that he can see in which plants are used. Food, furniture, paper, cloth, and wood construction are just a few of many uses which can be listed. To illustrate these uses, cut pictures of them from old magazines and put the pictures on a bulletin board. Also display as many actual examples as can be collected and brought to school.

ACTIVITY B

Visit a cotton mill to learn how cotton is converted into useful cloth.

ACTIVITY C

Visit a furniture factory to learn how wood is converted into useful furniture.

LIVING THINGS

ACTIVITY D

Visit a cigarette factory to learn how the leaves of a tobacco plant are made into cigarettes.

ACTIVITY E

Visit a nearby drug store and have the pharmacist discuss the nature and uses of some of the medicines which are derived from plants.

93. Plants are essential to maintaining life on the earth.

ACTIVITY

MATERIALS: poster paper, crayon

In preparation for a study of plants, begin a list of words relating to plants and another list of ways in which plants are helpful to us. Add to these lists throughout the study of plants.

94. Plants are made up of many different parts.

ACTIVITY

MATERIALS: several plants, paper, crayons

Bring some complete plants to school. Draw pictures of these plants, label their parts, and display the variety of pictures on a bulletin board.

95. Roots support plants and absorb food and water from the ground.

ACTIVITY

MATERIALS: access to vacant lot or field

Visit a vacant lot. Notice the manner in which the plants are attached to the ground and the upright position in which they stand. Carefully remove several plants, roots and all, from the ground. Try to make them stand up as before. Take the plants into the school room and keep them on a table for a couple of days. Notice that they wither and die. Relate your observations to the basic understanding given above.

96. Plant stems carry water to the leaves.

ACTIVITY

MATERIALS: celery, glass, water, red ink, blue ink, knife

Secure three pieces of celery. Cut off about an inch or two of the stems. Place one piece in a glass of clean water, one piece in water containing red ink and one piece in water containing blue ink. Examine the celery from time to time over a couple of days. Then remove the celery from the glasses and cut across the stem with a knife. Examine the cut ends of the stem carefully. The ink enables you to recognize the paths which water follows through the stem.

97. Leaves vary in size and shapes.

ACTIVITY

MATERIALS: leaves, newspapers, paper, glue, books on trees

Collect a variety of leaves. Press them between old newspapers until dry. Identify them and mount them on paper for display.

Plants

98. Leaves of plants contain a variety of colored pigments.

ACTIVITY

MATERIALS: green leaves, variegated coleus leaves, Japanese maple leaves, alcohol, 6 beakers or baby food jars, circular filter paper or paper towels cut in circles, pan, hot plate.

Tear coleus leaves into small pieces and put them in a beaker or baby food jar. In a second beaker, put pieces of green leaves and pieces of Japanese maple leaves in a third beaker. Cover the leaves with alcohol.

Boil the alcohol by putting the beakers into a pan of shallow water and heating. The pigments, such as chlorophyll, will pass from the leaves into the alcohol. Pour the alcohol into clean beakers or jars.

Make two parallel cuts about $\frac{1}{4}$ inch apart from the outer edge of a piece of filter paper to the center. Fold this wick down. Place the filter paper on top of the beakers of colored alcohol so that the wick is immersed in the alcohol solution.

The alcohol solution is absorbed up the wick of filter paper. Notice that the various colors move up the wick at different speeds. When the alcohol reaches the circle of filter paper, concentric rings form showing the different color pigments. Have the children discuss and explain the differences in the pigments of the three types of leaves.

99. Flowers produce the seeds of a plant.

ACTIVITY

MATERIALS: variety of flowers, books on flowers

Examine flowers from several different plants and see if you can find certain features the flowers have in common. Search in books for answers to what these features are and what purposes they have.

100. Seeds contain food for the growth of young plants.

ACTIVITY

MATERIALS: variety of fruits, knife

Cut open a number of seeds and have students note the stored food surrounding the embryo. Compare various types of arrangements of stored food.

101. Some plants produce seeds from which new plants grow.

ACTIVITY

MATERIALS: lima bean seeds, glass of water

To learn the important parts of a seed, soak some lima bean seeds overnight. The next day, examine them and locate the seed coat, stored food, and the tiny new plant. Discuss the importance of each of these parts.

102. Plants can be identified by characteristic parts.

ACTIVITY

MATERIALS: plant identification manuals

Take a walk around the neighborhood of the school and learn to identify trees, wild flowers, and other plants.

LIVING THINGS

103. Plants differ from each other in growth, structure, and reproduction.

ACTIVITY A

MATERIALS: references, representative plants

Plants can be classified as Thallophytes (algae and fungi), Bryophytes (mosses and liverworts), Pteridophytes (ferns), and Spermatophytes (seed-bearing plants). Collect samples of each of these groups and compare their structures.

ACTIVITY B

Take a trip to a wooded area and try to locate examples of algae, fungi, mosses, ferns, and seed plants. Compare these different groups of plants. In what ways are they similar? In what ways do they differ?

104. Algae are simple plants which contain chlorophyll but have no true stems, roots, or leaves.

ACTIVITY

MATERIALS: available algae, references, jars, microscope, microscope slide

Search in streams and ponds for a green substance growing on rocks. Collect samples in jars and bring them to school. If a microscope is available, examine the samples under a microscope and see if you can distinguish between different kinds of algae.

105. Fungi are plants without roots, stems, leaves, flowers, and chlorophyll.

ACTIVITY A

MATERIALS: milk, jar

To see the growth and effects of bacteria, put some milk in a jar, seal it, and put it in a warm place. Examine it after a few days.

ACTIVITY B

MATERIALS: mushrooms, toadstools, other fungi

Have the children collect, bring to class, and examine available fungi.

CAUTION: Many fungi are poisonous. Emphasize this fact and warn children that only an expert can tell which are nonpoisonous.

ACTIVITY C

MATERIALS: references

Gather information and discuss ways in which bacteria and other fungi can be helpful and ways in which they can be harmful. For example, some bacteria cause disease and spoil food whereas others help produce cheese and help keep the soil fertile.

106. Non-green plants obtain food from their environment.

ACTIVITY

MATERIALS: bread, jar with lid, water

Moisten a piece of bread with water, put the bread in a jar, and seal the lid firmly. Leave the jar in a warm, dark place for several days and then examine it carefully. Look for something growing on the bread. How does it differ from the plants that you normally see?

Plants

107. Mosses are small, simple plants which can be found in damp places.

ACTIVITY

MATERIALS: available mosses, hand lens, references

Collect a variety of mosses and examine them carefully with a hand lens to determine the important parts. Consult references to determine the importance of each part.

108. Ferns are plants which have roots, stems, and leaves and reproduce by spores.

ACTIVITY

MATERIALS: ferns, hand lens

Bring some potted ferns to class or ferns which are collected from the woods. Examine them carefully. Use a lens to examine the spores under the leaves.

109. Plants need water, air, sunlight, and minerals from the soil.

ACTIVITY

Have the children list all of the factors which they consider important to plant growth. The list could include such things as temperature, light, moisture, etc. Have the students devise experiments to test each of these conditions. Tests should involve using several samples of a particular plant which are similar and comparing the effects of various factors upon them. An opportunity to make measurements and record observations is available in this activity.

110. Green plants need air to live and grow.

ACTIVITY

MATERIALS: 2 potted plants, plastic wrap, string

Obtain two plants of the same kind and approximately the same size. Cover one carefully and wrap tightly with plastic so that air cannot get to it. Tie the plastic around the base firmly but not tight enough to harm the plant. Except for the covering on the one plant, treat both plants the same. Note carefully the changes and differences as time passes.

111. Plants need water to live and grow.

ACTIVITY

MATERIALS: 2 potted plants, water

Obtain two plants of the same kind and approximately of the same size. Water one of them regularly, but do not give the other one any water. Note carefully the differences as time passes.

112. Green plants need light in order to grow.

ACTIVITY A

MATERIALS: 2 young potted plants, box to cover one plant

Put one young potted plant by a window in the sunlight and a second potted plant of the same size under a box. Water both plants as needed and measure their growth each day. It may be surprising to some children that, for several days, the plant in the dark will grow more rapidly than the plant in the light. If the experiment is continued long enough, however, the plant under the box will die from lack of sunlight.

LIVING THINGS

ACTIVITY B

MATERIALS: 2 young potted plants, desk lamp with 60-watt bulb

Put one potted plant by a window in the sunlight. Put the other potted plant in a closet two feet away from a desk lamp. During the time of day that one plant is getting direct sunlight, turn on the lamp for the second plant. Water the plants as needed. Observe the plants from time to time over a period of several days. Is artificial light an adequate substitute for sunlight for growing plants? Repeat the experiment using bulbs of different wattage.

ACTIVITY C

MATERIALS: 4 flower pots, soil, rye seeds, cellophane (clear, red, yellow, blue)

Plant rye seeds in four flower pots of soil. Cover one pot with clear cellophane, one with red, one with yellow, and one with blue. Put all four pots by the window and observe for several days. Does the color of the light reaching the plants affect their growth?

113. During some seasons, certain plants do not grow.

ACTIVITY

Explore the school grounds, home gardens, and nearby farms. List plants which grow at some times of the year but not at other times. Discuss the reasons why many of these plants do not grow during the winter.

114. Plants grow best within a particular temperature range.

ACTIVITY A

MATERIALS: 2 bean seedlings, 2 thermometers, refrigerator

Obtain two bean seedlings as close to the same size as possible. Record the size of each plant by measuring height, size of leaves, number of leaves, etc.

Place one plant in a refrigerator, making sure that it is not in a position in which it will freeze. Place the other plant in the classroom where it will be at a normal temperature. Put a box over it so that it too will be deprived of light. Place a thermometer in the soil by each plant. Provide both plants with identical amounts of water. Every few days, have the children record the plant temperatures and measurements. Compare and draw conclusions concerning the effect of temperature on plant growth.

ACTIVITY B

MATERIALS: 2 bean seedlings, low wattage light bulb and socket, 2 boxes, 2 thermometers

Place a thermometer in the soil of each of two bean seedlings. Cover each seedling with a box to keep out the light. Partition one box so that a light bulb can be placed in it in such a way as to raise the temperature of the plant, but not expose it to light. Provide both plants with identical amounts of water.

Every few days, record the temperature of the seedlings and measure their growth (height, number of leaves, size of leaves, etc.). Compare the plants and determine the effect of temperature on growth. This comparison can be made most vivid by putting the collected data on graphs.

Plants

115. Plants need proper soil in which to grow.

ACTIVITY A

MATERIALS: several small jars, soil samples

Collect samples of soil from a variety of locations in jars and notice the types of plants which grow in each. Examine the soil samples and discuss how they differ. Does the soil in a carefully kept flower garden differ from the soil from a vacant lot? Would the flowers grow as well on the vacant lot? Why?

ACTIVITY B

Invite a teacher of agriculture or an agriculture extension agent to visit your class to display and discuss different types of soil.

116. Green plants produce food through the process of photosynthesis.

ACTIVITY A

MATERIALS: plants with leaves, aluminum foil

Cover several leaves of a plant with aluminum foil so that the light cannot get to them and place the plant in a sunny place. After several days remove the foil and examine the leaves. Is there any evidence that green plants need sunlight to carry out photosynthesis?

ACTIVITY B

MATERIALS: electric hot plate, pan, alcohol, small pan, bowl, tincture of iodine

Evidence of the production of starch in a green leaf can be demonstrated.

CAUTION: *Alcohol vapors will burn. Boil water on an electric hot plate and heat some alcohol over the boiling water.*

Break several geranium leaves into the hot alcohol and allow them to remain there until the green chlorophyll has been removed. Remove the leaves from the alcohol and put them immediately into hot water. Take them from the water and cover the leaves with tincture of iodine. After a few minutes a deep blue color will appear indicating the presence of starch which the plant produced.

117. Gases pass into and out of leaves through small openings on the underside of the leaves.

ACTIVITY A

MATERIALS: water plant, jar

Observe a leafy water plant in a jar of water. Notice how bubbles form on the leaves indicating that a gas is being given off.

ACTIVITY B

MATERIALS: water glass, glass funnel, test tube, wood splint, water weed

Turn a glass funnel with the tube pointing upward and hold some water weed in the large end. Put the funnel, large end down, into a glass of water. Fill a test tube with water and invert it over the tube of the funnel. Place the apparatus in strong sunlight. A gas will collect in the test tube. After sufficient gas is collected to test, light a wood splint and blow out the flame leaving a glowing spark on the splint. Insert the glowing splint into the test tube of collected gas. Oxygen causes the splint to burst into flame.

LIVING THINGS

ACTIVITY C

MATERIALS: leaves, razor blades, microscope, references

Examine the underside of a leaf and locate the tiny pores through which the plant breathes. For microscopic examination, it is helpful to slice a thin section from the bottom of the leaf. To gain a better idea of what to look for, consult reference books for pictures of stomata.

118. Green plants give off water vapor.

ACTIVITY

MATERIALS: potted plant, flower pot with soil, cardboard, tape, scissors, 2 jars

Obtain two identical flower pots, one with soil and a plant and the other containing only soil. Cut two pieces of cardboard large enough to fit on top of the flower pots. Place one piece of cardboard on the pot without a plant and cut a slit in the other which will permit you to slide it past the plant stem and over the other pot. Seal the slit with tape. Put a hole in the uncut cardboard the size of the hole left in the one which was cut. Invert a glass jar over the plant which sticks up through the cardboard and another jar over the open hole in the cardboard on top of the other pot. Place the two pots in the sun and examine them periodically. The jar over the plant becomes clouded, indicating that the plant is giving off water.

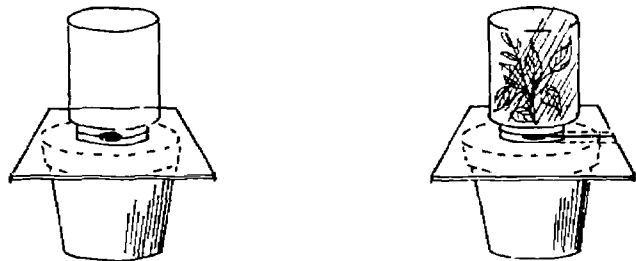

118

119. A variety of methods of reproduction have been found among plants.

ACTIVITY A

Visit a florist or invite a member of a local garden club to come to the school and discuss the ways in which plants are grown.

ACTIVITY B

Locate a florist, plant nursery operator, or some other individual who uses grafting in his work. Have him demonstrate the techniques and results of grafting as well as discuss the importance of this technique.

120. Green plants grow toward the light.

ACTIVITY A

MATERIALS: potted plant

Place the potted plant in the window. After a few days, notice the direc-

Plants

tion in which the plant is beginning to bend. Turn the pot and plant 180 degrees and notice if any change in direction of growth takes place during the following few days.

ACTIVITY B

MATERIALS: tagboard (2 pieces, 1"x12"), stapler, lamp

Green plants tend to grow toward the light. To illustrate this, staple one end of each of two 1"x12" pieces of tagboard together and hold the free ends together with one in each hand. Turn one side toward the light and make the other side "grow" by pushing up on the strip away from the light. Notice how the pair of strips appear to grow toward the light.

Continue to experiment with the strips. Can you see evidence for the fact that the dark side of the plant grows more rapidly than the light side resulting in the growth of a plant toward the light?

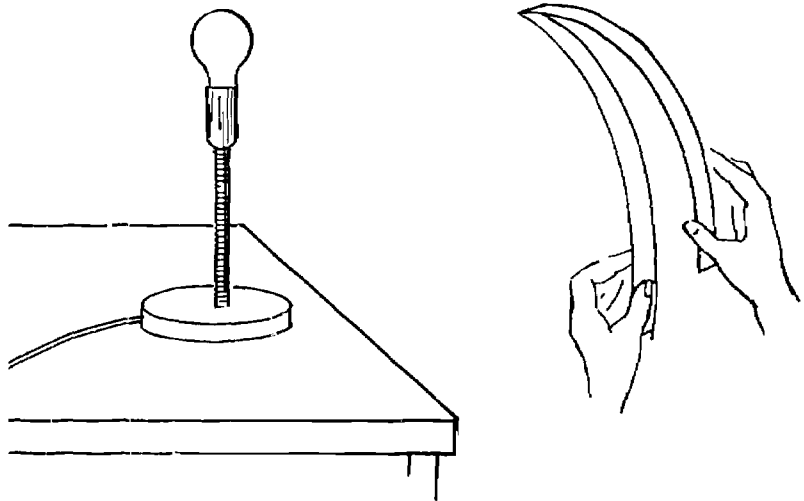

120 B

121. When a seed sprouts, stems will grow upward and roots will grow downward.

ACTIVITY

MATERIALS: drinking glass, paper towels, large bean

Build up layers of paper towels in a drinking glass until it is full. Place the bean seeds, facing in all directions, in a position where they can be seen between the paper towel and the side of the glass. Pour a little water on the towels in the glass and keep the seeds moist but not covered with water.

Observe the seeds for several days after they sprout. Does the direction in which the seed was pointing in any way determine the direction in which the stem and roots grow?

LIVING THINGS

122. Some plants grow from seeds.

ACTIVITY A

MATERIALS: seed catalog

Look around your home, garden, and neighborhood and locate different kinds of plants that people raise. Look at a seed catalog and identify the plants from the pictures. Gather as much information about the seeds as you can and discuss the differences in sources, size, germination period, planting time, etc. among seeds.

ACTIVITY B

MATERIALS: 2 cake pans, garden soil, package of new lettuce seeds, package of year-old lettuce seeds

To determine whether or not age affects the germination of seeds, fill two cake pans with garden soil and plant fifty new seeds in one and fifty of the year-old seeds in the other. Keep the soil moist and count the number of plants in each pan when the young plants begin to grow. What conclusions can you draw?

123. Some plants grow from bulbs.

ACTIVITY

MATERIALS: variety of plant bulbs

Purchase a variety of plant bulbs from a seed store. Inquire about the proper season for planting them and when they can be expected to grow. Following instructions, plant them on the school grounds and when the plants grow, dig them up and examine them carefully to determine what changes took place.

124. Some plants can be grown from roots.

ACTIVITY A

MATERIALS: carrot, small jar, water

Cut the top inch or two off a carrot and place it partially submerged in a jar of water. The carrot is a root from which a plant will grow.

ACTIVITY B

MATERIALS: sweet potato, jar, water

A sweet potato is a root. Put a sweet potato in a jar and partially cover it with water. A plant will eventually grow from the sweet potato.

125. The stems cut from some plants grow into new plants.

ACTIVITY A

MATERIALS: geranium plant, jar, water

Cut across the stem of a geranium plant a few inches below the tip. Remove all but two or three of the highest leaves and place the base into a jar of water. Make several such cuttings and put them in water. Some will develop roots and can be transferred to soil and grow as new plants.

ACTIVITY B

MATERIALS: pussy willow twig, jar, water, flower pot, soil

Place a pussy willow twig in a jar of water. When roots grow on the twig, transfer it to moist soil in a flower pot. A new plant will grow from the twig.

Plants

- 126. Some plants can be grown from leaves.**

ACTIVITY

MATERIALS: snake plant, flower pot, soil

Cut the leaf of a snake plant into segments about two inches long. Stand them up in soil so that they are partially covered and partially exposed above the soil. New plants will grow from some of these leaf segments.

- 127. The quality of plants can be improved considerably by careful selective breeding.**

ACTIVITY

Invite a florist, plant nursery operator, or an agricultural agent to visit the class and describe what selective breeding is and how and why it is used.

- 128. Hybrid plants are produced from two different strains of plants.**

ACTIVITY A

MATERIALS: seed and plant catalog

To gain an insight into the large number of hybrid plants which are now available, look through a seed and plant catalog and estimate the percent of plants advertised that are hybrids.

ACTIVITY B

MATERIALS: references on the work of Luther Burbank

Ask a group of children to investigate and report to the class their findings on the life and work of Luther Burbank. Include information about some of the hybrid plants which he produced.

- 129. The theory of evolution holds that the characteristics of plants change over a long period of time.**

ACTIVITY

MATERIALS: references

Obtain pictures of plants which are believed to have lived millions of years ago and from which our coal is believed to have been formed. Why are many of these plants no longer in existence? Why are there presently many plants in existence which were not on the earth at that time?

- 130. Care must be taken to preserve natural plant life.**

ACTIVITY A

MATERIALS: letter paper

Write to the State Parks Division, Department of Conservation and Development, in Raleigh, North Carolina. Request information on the State parks in North Carolina. From this information, what can you learn about ways in which the State is contributing to the conservation of plant life?

ACTIVITY B

Invite a forest ranger to discuss with the class the method being employed to harvest forest products and, at the same time, to maintain a steady crop of trees.

III. MATTER AND ENERGY

A. Matter

131. Modern life requires that we use many different kinds of matter.

ACTIVITY

MATERIALS: wood, glass, metal, plastic, cloth, etc.

Examine a variety of materials and list some of the uses of each. Discuss the importance of having a variety of materials available to provide for different needs. Discuss such things as what you would use for windows if you did not have glass or what you would use for clothing if you did not have cloth.

132. A variety of materials are needed to fulfill the demands of modern life.

ACTIVITY

MATERIALS: objects made of a variety of materials

Have the children list the types of materials which make up most of the things around them. Under each, list everything that they can think of which contains that particular material. Collect and display samples of as many different materials as you can locate.

133. Some matter is heavier than other matter.

ACTIVITY

MATERIALS: tall thin jar (such as an olive jar), salad oil, water, water soluble ink, spoon, eyedropper

Fill a tall, thin jar about half full of salad oil. Color some water with soluble ink and pour the colored water slowly into the tall jar until the jar is almost full. Observe carefully as you pour. Explain your observations.

134. All matter has a tendency to remain at rest unless an outside force moves it. This tendency is called inertia.

ACTIVITY A

MATERIALS: glass of water, sheet of paper

Place a glass of water on one end of a sheet of paper. Grasp the other end of the paper and pull it quickly toward you. The paper is removed from under the glass of water but the glass does not move due to its inertia.

ACTIVITY B

MATERIALS: 2 rocks, string

Locate two rocks about the size of softballs and hang them from a tree limb or some sort of cross bar using string which is just strong enough to hold them. Allow an extra length of string to dangle below the rocks. If a pull is exerted on the string below the rock, will the string break above or below the rock?

If the pull is a steady pull, it will break above the rock due to the added weight of the rock. If the pull is a sudden, quick jerk it will break below the rock because of the inertia of the rock and its tendency not to move.

Matter

135. Matter exists in solid, liquid, and gaseous forms.

ACTIVITY

MATERIALS: hot plate, pan, ice cubes

Put a pan containing ice cubes on a hot plate and heat. Observe carefully the change from a solid to a liquid and from a liquid to a gas.

136. Heat is needed to evaporate a liquid to a gas.

ACTIVITY

MATERIALS: thermometer, cardboard, cotton

Moisten your finger and blow on it. As the liquid evaporates, does it seem cooler? Is it really cooler? To find out, moisten a piece of cotton and attach it to the bulb of a thermometer. Fan the moist cotton with a piece of cardboard. Notice how the temperature goes down as the water evaporates. Evaporation required heat which, in this experiment, was obtained from the finger and the bulb of the thermometer.

137. Heat affects the speed of evaporation.

ACTIVITY

MATERIALS: 2 water glasses, water

Place equal amounts of water in two glasses. Put one glass on a warm radiator and the other glass in a cool part of the room. Observe from time to time to see which one evaporates faster. Your observations will show that heat speeds evaporation.

138. Wind increases the speed of evaporation.

ACTIVITY A

MATERIALS: wet cloth, blackboard, cardboard

Make two wet spots about ten feet apart on a blackboard. Fan one vigorously with a piece of cardboard. The spot which has been exposed to the moving air will dry faster than the other.

ACTIVITY B

MATERIALS: 2 identical small bowls, electric fan, water

Put equal amounts of water in two identical small bowls. Place one bowl in front of an electric fan and the other in a cupboard or drawer where there is a minimum of air movement. Observe both bowls from time to time. The water exposed to the fan will evaporate more rapidly.

139. The amount of exposed surface affects the speed of evaporation of a liquid.

ACTIVITY

MATERIALS: dish, tall, narrow jar or large test tube, measuring cup

Put equal amounts of water in a dish and a tall, narrow jar. Put the dish and jar side by side and observe from time to time until all of the water evaporates from one of them. The greater the surface exposure, the more rapidly evaporation will take place.

140. Water condenses from a gas to a liquid when heat is removed from it.

ACTIVITY

MATERIALS: drinking glass, ice, water

Fill a drinking glass about half full with lukewarm water. Is there any change on the outside of the glass? Add ice to the water. Notice mois-

MATTER AND ENERGY

ture collecting on the outside of the glass. Where does the moisture come from?

141. Some substances dissolve in water more readily than others.

ACTIVITY A

MATERIALS: several small jars, water, spoon, a variety of substances (salt, sugar, flour, baking soda, sand, etc.)

Pour small amounts of various substances in separate jars of water and stir. Divide the materials into two groups depending on whether they dissolve in water.

ACTIVITY B

MATERIALS: 3 water glasses, water, salt, sand, sugar, 3 teaspoons

To show that some materials dissolve in water and others do not, pour a teaspoonful of salt into a glass of water and stir it for about one minute. Observe what happens. Then pour a teaspoonful of sand into a second glass of water and stir it for about one minute. Again, observe carefully. Finally, pour a teaspoonful of sugar into a third glass of water and stir it for one minute. Observe and compare with salt and sand.

ACTIVITY C

MATERIALS: lamp chimney, sand, cloth, fine soil, salt, water, spoon, 2 jars, string

Pour three tablespoons of salt and an equal amount of fine soil into a jar of water. Stir and mix thoroughly. Tie a cloth over one end of a lamp chimney, fill the lamp chimney with sand, and hold it over an empty jar. Pour the muddy water into the top of the lamp chimney and collect what passes through into the clean jar. The water which passes through is clear and has a salty taste. The soil was not dissolved in the water and was therefore filtered out by the sand. The salt, however, was dissolved and passed through with the water.

142. The amount of salt which can be dissolved in water changes as the temperature of the water changes.

ACTIVITY

MATERIALS: Pyrex beaker, water, teaspoon, stirring rod, salt, hot plate

Using a teaspoon, add a few salt crystals at a time to cold water in a Pyrex beaker and stir until they are dissolved. Continue to add salt until no more will dissolve. Place the beaker on a hot plate and gradually increase the temperature while adding salt to the solution. Continue to add salt until the water is boiling and no more salt will dissolve.

Keep a record of how many teaspoonfuls of salt can be dissolved in cold water, warm water, and hot water. Draw a graph to show the variation in solubility.

143. Some solid materials exist as crystals.

ACTIVITY A

MATERIALS: pan, water, salt, dish, magnifying glass, string

Matter

Dissolve some salt in hot water. Pour the water on a string which is lying on a dish. Allow the water to evaporate. Examine the crystals of salt on the string with a magnifying glass.

ACTIVITY B

MATERIALS: snow, magnifying glass

During a snowfall, catch a snowflake lightly on your glove and examine it carefully with a magnifying glass. Notice the regular, crystalline structure.

144. All matter is made up of atoms which contain electrons, protons, and neutrons. (Exception: Regular hydrogen does not contain neutrons.)

ACTIVITY

MATERIALS: references, paper, crayons

Have the children consult references and locate the structures of as many different atoms as possible. Draw these structures using one color for electrons, another color for protons, and still another for neutrons. Display and compare these drawings. Notice that no two atoms of different elements are the same. What other general conclusions can be drawn from looking at these structures?

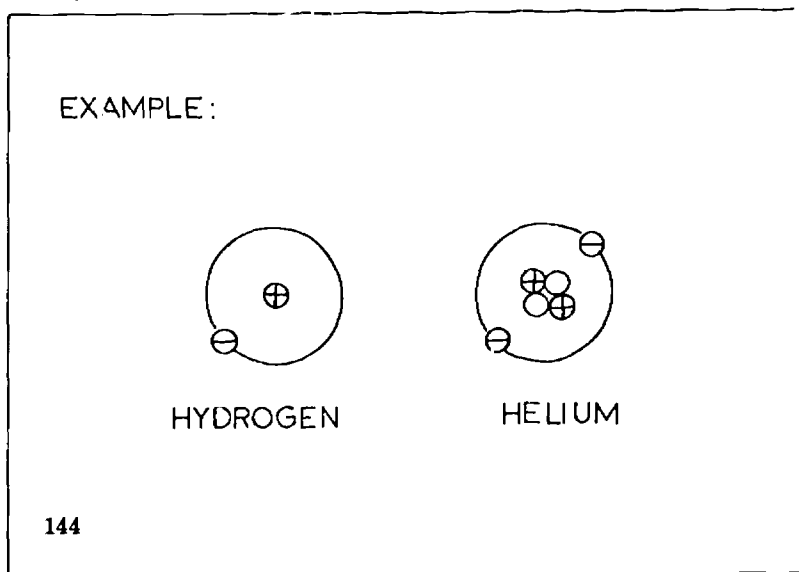

145. All matter is made up of one or more of the 103 basic chemical elements.

ACTIVITY A

MATERIALS: blocks, tinker toys, erector set

Use blocks, tinker toys, an erector set, and the analogy that all music is written from relatively few notes on a musical scale to illustrate the idea that few basic elements can make up many things.

Build a variety of structures with blocks, tinker toys, and an erector set. If you play a musical instrument, play several songs all of which use the same musical notes. Use these examples to illustrate the idea that a few basic elements can be employed in a variety of proportions and procedures to make many different things.

MATTER AND ENERGY

ACTIVITY B

MATERIALS: table, cards (3" x 5"), list of chemical elements, collected elements

Using a list of chemical elements as a guide, collect samples of as many different elements as you can locate. Display them on a table. With each, put a card indicating the name of the element and any other interesting information which can be located about it.

146. All matter is made of tiny particles called atoms and molecules.

ACTIVITY A

MATERIALS: clay

Cut a piece of clay in half. Take half and cut it in half. Continue with this process until you have reduced it to as small a piece as you can cut. Pose a question to the children concerning what they believe would happen if you could continue to cut the piece of clay. Develop the idea that it eventually you would reduce it in size until it could no longer be cut. You would then have reached the smallest particle of that material, namely, the atom.

ACTIVITY B

MATERIALS: worn objects

Ask the children for evidence of the idea that all objects are made of tiny particles. Show them several worn objects and point out such things as the evaporation of water as evidence of the loss of unseen particles.

ACTIVITY C

MATERIALS: water glass, sugar, water

Examine some sugar and a glass of water carefully. Pour a teaspoonful of sugar into the water and stir. The sugar will dissolve. Lead the children to understand that the sugar divides into tiny particles which cannot be seen. Taste the water to confirm that the sugar is in it.

147. Molecules are constantly in motion.

ACTIVITY

MATERIALS: references, water, cloth, chalkboard

Have the children check references for the chemical makeup of water. They will find that two atoms of hydrogen combine with one atom of oxygen to produce a molecule of water. Using a damp cloth, make a wet streak across a chalkboard. As it dries, discuss why it evaporates. Lead the children to see that the constant motion of the water molecules is what causes them to leave the chalkboard and this results in drying.

B. Energy

148. Energy is the ability to do work. It exists in a variety of forms.

ACTIVITY

MATERIALS. devices which represent different forms of energy

Energy can exist in the form of mechanical, electrical, chemical, wave, heat, and atomic energy. Examine various devices which you can use to do work for you or assist you in your work and determine what forms of energy are represented in each.

149. Energy may be potential or kinetic.

ACTIVITY

MATERIALS: block of wood, table

Place a block of wood on the floor beside a table. Point out that the wood is not in a position to release mechanical energy and do work. Lift the block of wood to the table and, while doing so, point out that you are doing work on the block and therefore giving it energy. While the block is on the edge of the table, it is in a position to release its energy simply by falling off. Since it possesses this energy ready to be released, the type of energy is called potential energy.

Slide the block off the table. As it falls, the energy of motion which it releases is kinetic energy. The maximum potential energy of the block is at the top of its fall. The maximum kinetic energy is the instant before it hits the ground. Between these two positions, the block has both potential and kinetic energy.

150. Energy exists in many forms.

ACTIVITY

MATERIALS: old magazines, crayons, scissors, glue, paper

Heat, electrical, atomic, light, sound, chemical, and mechanical are some of the forms of energy. Prepare a bulletin board display illustrating each one of these with pictures which the children draw and pictures which they cut from magazines.

151. Energy can be changed from one form to another.

ACTIVITY A

MATERIALS: tools and appliances

Examine several tools, appliances, and other devices and discuss what types of energy are applied to each and what types of energy are produced by each. For example, an electric iron converts electrical energy to heat energy. An electric light converts electrical energy to heat and light (or wave) energy.

ACTIVITY B

MATERIALS: old magazines, crayons, scissors, glue, paper

Have the children draw or cut from old magazines examples of devices which change energy from one form to another. Then have them either label or symbolically indicate what kind of energy goes into the device and what kind comes out. Display these illustrations on a bulletin board.

MATTER AND ENERGY

ACTIVITY C

Rub your hands together vigorously. The friction between your hands will cause them to become quite warm. Mechanical energy is being converted into heat energy.

ACTIVITY D

MATERIALS: comb, paper

Run a comb through your hair several times. Touch the comb to small pieces of paper. The paper is attracted by the static electrical charge on the comb. Mechanical energy is converted to electrical energy.

152. There are many different sources of energy.

ACTIVITY

MATERIALS: references, variety of energy sources

Assign individual children to demonstrate a source of each of the various forms of energy. These forms should include heat, electrical, mechanical, chemical, atomic, sound, and light. Have them consult references if they cannot think of simple examples. Demonstrations can include a luminous dial clock for atomic energy, the reaction of vinegar and baking soda for chemical energy, etc.

153. Matter can be converted into energy and energy can be converted into matter.

ACTIVITY

Have each child write his name with a pen. Looking at what he has written, have him estimate how much work he thinks could be done if all the ink used to write his name was changed into energy. The conversion of matter into energy takes place according to Einstein's equation $E=mc^2$. E stands for energy, m stands for mass, and c stands for the speed of light. The ink in a twelve letter name, if converted to energy, could lift a 100,000 ton ocean liner 35 feet into the air.

Atomic Energy

C. Atomic Energy

154. The nucleus of an atom contains protons and neutrons. (Exception: The nucleus of one form of hydrogen does not contain neutrons.)

ACTIVITY

MATERIALS: clay (2 different colors), references

Make small balls of clay. Use one color of clay to represent neutrons and another color to represent protons. Consult references which show the structure of atoms and make models of several atomic nuclei. If only the atomic number and atomic weight of atoms can be located, round off the atomic weight to the nearest whole number. The atomic number is the number of protons and the difference between the atomic number and atomic weight is the number of neutrons.

155. Certain types of atoms tend to break down and give off energy. These atoms are radioactive.

ACTIVITY

MATERIALS: luminous dial clock

Examine a luminous dial clock or watch in a dark room. The light which is given off results from atoms changing and giving off energy.

156. The nuclei of radioactive atoms spontaneously emit radiation.

ACTIVITY

MATERIALS: Ping-Pong ball gun, water pistol

Nuclear radiation can take the form of particles or rays of energy which are emitted spontaneously. To illustrate this, conceal a Ping-Pong ball gun in one hand and a water pistol in the other. Roll your hands over one another to demonstrate the motion of the particles within an atomic nucleus. Without warning, shoot a Ping-Pong ball toward the class and then squirt water at them from the water pistol. Point out the analogy between these and radioactive emissions from an atomic nucleus.

157. Atoms are the most recently developed source of energy.

ACTIVITY

MATERIALS: references

Have the children search through references and gather information on the people and events which have led to the harnessing of atomic energy.

158. Atoms release energy by nuclear fission and nuclear fusion.

ACTIVITY A

MATERIALS: set of dominoes

The idea of a chain reaction of atoms releasing energy and causing other atoms to release energy can be illustrated with a set of dominoes. Stand the dominoes on their ends and arrange them so that as each one falls, it strikes another causing it to fall.

MATTER AND ENERGY

ACTIVITY B

MATERIALS: plywood (6" x 6"), wooden matches, a nail the diameter of the matches, hammer

A chain reaction of atomic fission takes place when one atom becomes unstable and breaks down giving off energy and neutrons. These neutrons then strike other atoms which in turn give off more neutrons which strike more atoms, etc.

To illustrate a chain reaction, make a group of holes in a triangular pattern on a piece of plywood. A hole can be produced by hammering a nail about halfway through the plywood and then removing it. Insert the untreated end of a wooden match into each hole. Holding the block of wood vertically, touch a lighted match to the head of the match in the extreme bottom of the triangular group. One match will cause others to burn until the entire group of matches is aflame. Compare the match heads to atomic nuclei and the spread of the fire to a chain reaction.

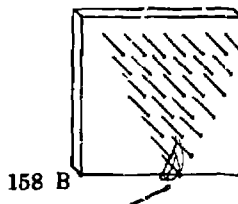

ACTIVITY C

MATERIALS: plywood, 2 pieces (4" x 8"), wooden matches, a nail the diameter of the matches, hammer

In order for a large group of atoms to release their energy in a chain reaction, it is necessary to have sufficient atoms present so that free neutrons can effectively strike other atoms. The amount of material needed to provide the necessary number of atoms is called the critical mass.

To illustrate critical mass, make a scattered group of holes several inches apart on each of two pieces of plywood. The holes can be produced by hammering a nail about halfway through the plywood and then removing it. Insert the untreated end of a wooden match into each hole. Holding the blocks of wood vertically, have someone touch a lighted match to the head of the match at the bottom of the group on each board. Because of the distance between matches, only one match on each board burns. However, when the boards are brought together face-to-face, the match heads are closer together resulting in all of them being ignited in a chain reaction. The bringing of the two boards together can be compared to the bringing of sufficient nuclear fuel together to produce a critical mass.

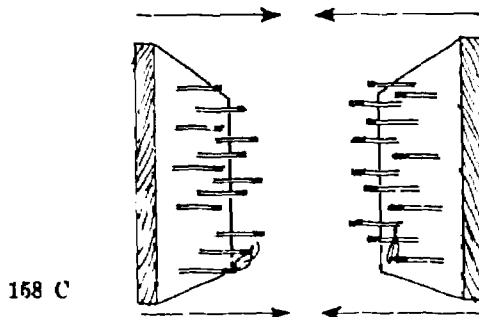

Atomic Energy

ACTIVITY D

MATERIALS: references, crayons, paper

Locate information about atoms which undergo fission and the products of a fission reaction. Draw a diagram of the original atom and the fission products.

ACTIVITY E

MATERIALS: crayons, paper

Nuclear fusion is the release of energy as a result of the joining of two atomic nuclei. Have the children draw diagrams of the original components and the resulting products of a fusion reaction in which a hydrogen atom containing one proton and one neutron (deuterium) combines with a hydrogen atom containing one proton and two neutrons (tritium) to produce a helium atom with two protons and two neutrons plus a free neutron.

EXAMPLE:

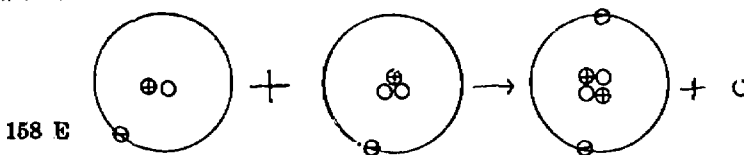

159. Atomic energy can be harnessed to do work.

ACTIVITY A

Phone or write your local electricity company for information on the nearest generating plant which uses atomic energy to produce electricity. Perhaps they can provide you with a pamphlet which includes pictures of a generating plant, etc.

ACTIVITY B

MATERIALS: model of atomic submarine, references

Obtain a model of an atomic submarine from a hobby shop and have the children assemble it. Examine the atomic engine and consult references to learn how the engine operates and what important functions it provides for the submarine.

160. Many applications have been developed for the use of atomic energy.

ACTIVITY

MATERIALS: references

Have the children prepare reports on the variety of uses of atomic energy. Areas in which this form of energy is being employed include transportation, space exploration, medicine, agriculture, generating of electricity, industrial processes, and national defense.

MATTER AND ENERGY

D. Chemical Energy

161. A physical change is a change in form but not a change in composition of a substance.

ACTIVITY A

MATERIALS: hot plate, water glass, pan, water

Boil some water in a pan on an electric hot plate and hold a glass of cold water about a foot above the boiling water. The liquid water will change to a gas and, upon touching the glass of water, will change back to a liquid. Since the liquid, gas, and liquid are all water, the changes which take place are all physical changes.

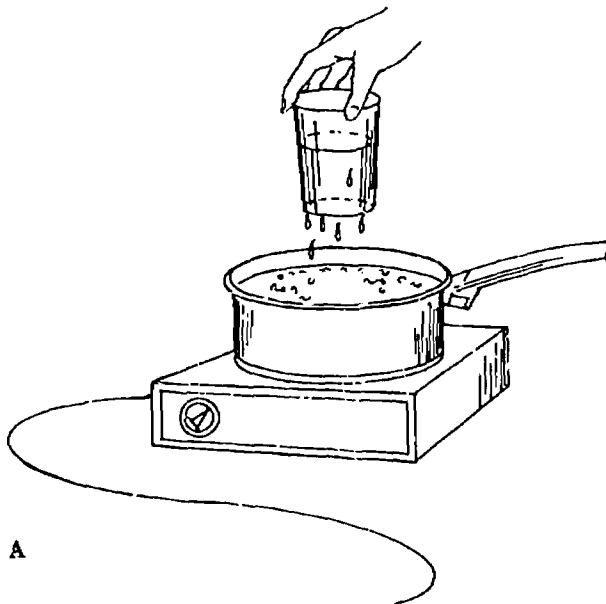

161 A

ACTIVITY B

MATERIALS: candle, small pan, ice cube, refrigerator

Put an ice cube in a small pan and heat it over a candle. The ice cube will melt. Put the pan into the freezing compartment of a refrigerator. Ice will again be formed. If heated over the candle flame, the ice will again melt. Since ice is a solid form of water, no new substance is formed. The changes which take place, therefore, are physical changes.

ACTIVITY C

MATERIALS: hot plate, pan, paraffin

Heat a piece of paraffin in the top pan of a double boiler on an electric hot plate. The paraffin melts. Cool the paraffin. It becomes solid again. Since the solid and liquid forms are both paraffin, the changes which take place are physical changes.

Chemical Energy

ACTIVITY D

MATERIALS: hot plate, pan, sugar, water

Put about a cup of water in a pan, add about a tablespoonful of sugar and stir until the sugar dissolves. Put the pan on an electric hot plate and heat until all the water evaporates. Heating should be slow to avoid charring. Crystals of sugar can be seen remaining in the pan. Since no new substance was formed, all changes in the sugar which took place were physical changes.

162. Substances can be identified by their chemical properties.

ACTIVITY

MATERIALS: 2 water glasses, potato starch, flour, lettuce, potato, tincture of iodine, water, teaspoon

The chemical reaction between iodine and starch can be observed by adding several drops of tincture of iodine to a mixture of potato starch and water in a glass. Test flour in water; then test a potato, lettuce, and other substances for starch by bringing iodine in contact with them.

163. A chemical change is a change in the composition of a substance.

ACTIVITY A

MATERIALS: test tube, test tube holder, sugar, candle

Put a small amount of sugar into a test tube and heat it over a candle flame. Soon the sugar will turn black and moisture will form on the side of the tube. Since the sugar has been broken down into new substances, a chemical change has taken place. Some students may want to devise and perform tests to determine what substances are formed from the sugar.

ACTIVITY B

MATERIALS: test tube, test tube holder, candle or gas burner, wood splints

Break two wood splints into small pieces and put them in a test tube. Heat the tube with a candle or gas burner. The wood will turn black and moisture and tars will form on the inside of the test tube. Since the wood has broken down and new substances have formed, a chemical change has taken place.

164. A chemical change is taking place when a substance changes to a new substance.

ACTIVITY

MATERIALS: jar, milk

Pour some milk into a jar and put the jar in a warm place for a few days. Compare the resulting sour milk with some fresh milk. Since the milk has changed to new substances, the change was a chemical change.

165. A mixture is a combination of two or more substances which do not combine chemically.

ACTIVITY

MATERIALS: powdered sulfur, iron filings, magnet

Examine some powdered sulfur and iron filings carefully. Notice the color of each and the fact that the iron filings can be attracted to a magnet but the sulfur cannot. Mix the iron and sulfur together thoroughly. Can you still distinguish particles of iron from particles of sulfur? Can the iron be separated from the sulfur by means of a magnet? Since the sulfur and the iron have not been changed in any way, this combination of the two is a mixture.

MATTER AND ENERGY

166. Chemical compounds are made up of two or more elements.

ACTIVITY A

MATERIALS: iron filings, sulfur, test tube, magnet, alcohol burner

Examine some powdered sulfur and iron filings carefully. Notice the color of each and the fact that the iron filings can be attracted to a magnet. Mix about two teaspoonfuls of sulfur with about one teaspoonful of iron. Put the mixture in a test tube and heat until it glows. Remove the contents of the test tube by pouring cold water over the hot test tube. This will shatter the glass. It can then be easily broken and the contents examined.

CAUTION: *Extreme care should be exercised in protecting the eyes from flying glass.*

Notice that the iron and sulfur are no longer distinguishable and that the substance formed is not attracted to a magnet. A compound of iron and sulfur has been formed by a chemical reaction.

ACTIVITY B

MATERIALS: sugar, hard glass test tube, test tube holder, candle, match, teaspoon

Sugar is a compound that is made up of carbon, hydrogen, and oxygen ($C_{12}H_{22}O_{11}$). This composition can be demonstrated by putting about a half teaspoon of sugar into a hard glass test tube. Using a test tube holder, hold the test tube in a candle flame until the sugar changes color and ceases to bubble. The black substance which is formed in the bottom of the test tube is carbon. The moisture which forms on the side of the test tube is water which contains the hydrogen and oxygen.

167. Each chemical element is represented by a different symbol.

ACTIVITY

MATERIALS: references

Have the children compile a list of all of the chemical elements and write the symbol for each. Discuss the value of having symbols for the chemical elements.

168. Chemical formulas indicate the elements which make up a substance and the proportions in which they are combined.

ACTIVITY A

MATERIALS: periodic chart of elements or list of elements and symbols

Show the children a list of chemical formulas such as HCl, H_2SO_4 , NaCl, KCl, $AgNO_3$, SiO_2 , $CaCO_3$, etc. Have them determine the elements present in each and the number of atoms of the element for each molecule of the compound.

ACTIVITY B

MATERIALS: chemistry set, periodic chart or list of chemicals and symbols

Have some of the children who own chemistry sets do simple experiments for the class. Write on the chalkboard the formulas of the chemicals being used and have the children identify the elements involved.

Chemical Energy

169. The reaction between two chemicals can be symbolically represented by a chemical equation.

ACTIVITY

MATERIALS: chalkboard, references

Write several chemical equations on the blackboard such as:

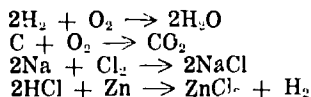

Have the children discuss each equation and point out the elements and compounds involved.

170. An acid causes blue litmus paper to turn red.

ACTIVITY

MATERIALS: blue litmus paper, variety of household substances

Test foods, medicines, cleaning solutions, and other liquids and solutions with blue litmus paper to determine which ones belong to the large group of compounds called acids.

171. A base causes red litmus paper to turn blue.

ACTIVITY

MATERIALS: red litmus paper, variety of household substances

Test foods, medicines, cleaning solutions, and other liquids and solutions with red litmus paper to determine which ones belong to the large group of compounds called bases.

172. Salt: make up a common group of chemical compounds.

ACTIVITY

MATERIALS: chalkboard

Show the children the following formulas for salts.



On the basis of these formulas, ask them to distinguish salts from acids. (examples: HCl, H₂SO₄, HNO₃) and bases (examples: NaOH, KOH, Ca(OH)₂).

173. When a substance combines with oxygen, a new substance is formed which belongs to a group of compounds called oxides.

ACTIVITY

MATERIALS: periodic chart or table of elements and symbols, chalkboard

List for the children formulas for several oxides such as:



Have them determine how the formula of an oxide can be identified. Have them also identify the element which combined with oxygen. Expand the activity with additional examples.

MATTER AND ENERGY

174. When iron combines with oxygen, rust is formed.

ACTIVITY A

MATERIALS: jar, water, iron nail

Stand an iron nail in a jar and partially cover the nail with water. Put a lid on the jar and allow it to stand for several days. Rust will gradually form on the nail. The rust results from oxygen combining with the iron.

ACTIVITY B

MATERIALS: drinking glass, bowl, water, steel wool

Moisten a piece of steel wool and place it in the bottom of a drinking glass in such a way that it won't fall out. Invert the glass and place it in a bowl containing about an inch of water. Observe the water level over a period of several days and explain any change. As the iron in the steel wool rusts, it uses oxygen. Since oxygen is taken from the air within the glass, this results in the water level rising in the glass.

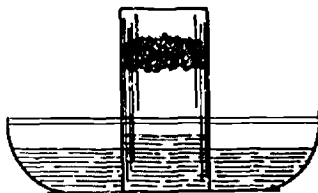

174 B

175. Paint can be used to prevent rust.

ACTIVITY

MATERIALS: jar, 2 iron nails, water, paint

Paint an iron nail. After the paint has dried, put it and an unpainted iron nail into a jar and partially cover them with water. Put a lid on the jar and allow it to stand for several days. The unpainted nail will rust, but the painted nail will remain unchanged.

176. Rapid oxidation produces a flame.

ACTIVITY

MATERIALS: candle, matches, wood splints

Light a candle. Observe the flame carefully. Insert wood splints into various positions above, beside, and within the flame. Observe the splint noting what happens to it in different positions. What can you learn about the flame? What parts of the flame seem to be hottest? What parts of the flame seem to be coolest? What parts of the flame are brightest? What other observations can you make about the flame?

177. Oxygen in the air supports burning.

ACTIVITY

MATERIALS: 3 candles, quart jar, gallon jar, match

Light three candles. Simultaneously place an inverted quart jar over one, a gallon jar over another, and leave the third uncovered. Observe the candles until the two which are covered go out. What conclusions can you draw concerning the importance of air in burning?

Chemical Energy

- 178. A fire requires fuel, oxygen, and the kindling temperature of the fuel.**

ACTIVITY

MATERIALS: candle, matches

Point to the air in front of you and ask the children why you can't make fire appear there. Lead them to suggest that it is necessary to have something to burn. Hold a candle in the area that you pointed to and ask why it is not burning. Lead them to see that it is necessary to light it or, rather, raise its temperature to the kindling point. Once the candle is burning, quickly pinch the wick with your forefinger and thumb. Why does the flame go out? Lead the children to see that your fingers have kept oxygen from getting to the flame and lowered the temperature below the kindling temperature.

- 179. Fires may be extinguished by removing one or more of the three conditions required for a fire.**

ACTIVITY

Invite a forest ranger to discuss with the class how forest fires are combated. Have him give examples of fire fighting methods which remove the source of fuel, lower the kindling temperature, and prevent the fire from receiving oxygen.

- 180. A fire can be extinguished by preventing it from gaining oxygen.**

ACTIVITY

MATERIALS: carbonated soft drink, water glass, matches

Carbonated soft drinks contain carbon dioxide. Carbon dioxide is a gas which neither burns nor supports burning. If a fire is surrounded by carbon dioxide, oxygen cannot get to it and it will go out. To illustrate this, pour a carbonated soft drink into a glass and while the carbon dioxide is bubbling from it, hold a match over it. The flame will be extinguished due to lack of oxygen.

- 181. Energy can be released by burning fuels.**

ACTIVITY A

Have the children check in their homes and neighborhood to determine what fuels are used to provide useful energy and do useful work. Discuss the variety of fuels and the devices which use them.

ACTIVITY B

Have the children collect samples of various fuels. Display these samples and discuss their uses.

- 182. A variety of types of fuels are necessary to meet the broad range of modern needs.**

ACTIVITY

MATERIALS: samples of fuels, references

Bring to class samples of as many different fuels as you can locate. Label each sample and list some of the ways in which it is used. Explore references to locate names and information on other fuels. Include special rocket fuels, fuels for fuel cells, and other developments in this area which have commanded close attention in recent years.

- 183. Spontaneous combustion takes place when enough heat is produced in a confined place to reach the kindling temperature of the surrounding material and cause it to ignite.**

ACTIVITY A

Discuss with the children the conditions which bring about spontaneous combustion. These include, substances with a low kindling temperature

MATTER AND ENERGY

such as oily rags enclosed in an unventilated area where heat cannot escape. Have the children search their homes for such locations and volunteer to assist their parents in cleaning them up.

ACTIVITY B

MATERIALS: paper towels, large can of dirt, potassium permanganate, glycerine

CAUTION: *This experiment can be dangerous if not conducted carefully. It should be demonstrated only by the teacher with children standing back at a safe distance.*

Pour about a teaspoonful of potassium permanganate in the center of a paper towel. Pour an equal amount of glycerine on the potassium permanganate and quickly crumple the paper towel around the mixture. Surround these with another paper towel, place them on top of a can of dirt, and watch carefully. After a short period of time, enough heat will build up to cause the paper to burst into flame.

184. Some chemicals can be effectively used to extinguish fires.

ACTIVITY

MATERIALS: baking soda, wide-mouth jar, vinegar, tablespoon

Put a tablespoon of baking soda in a wide-mouth jar and slowly add vinegar. As a gas bubbles off, light a match and hold the flame inside the jar. What conclusions can you draw about the gas that is produced?

185. Safety precautions should be taken to protect our homes from fires.

ACTIVITY

Have the children examine their homes for areas which may cause or feed fires. Have them discuss these areas with their parents and offer to help clean them or do what is necessary to make them safe.

186. Safety precautions should be taken to prevent and to prepare for combating destructive fires.

ACTIVITY A

Review the rules for a fire drill. Practice the drill until it is carried out efficiently and everyone knows exactly what he is to do.

ACTIVITY B

Draw a floor plan of your school. Check through the school and locate fire alarms and fire extinguishers. Mark their locations on the floor plan and see how many children can learn all of the locations.

ACTIVITY C

Invite a fireman to the classroom to discuss rules of fire safety.

ACTIVITY D

Visit a fire station and learn about the equipment which is used and techniques which are used for fighting fires.

ACTIVITY E

MATERIALS: newspapers

Collect from old newspapers accounts of destructive fires. Pay particular attention to the cause of each fire. Compile a list of different causes and discuss how these fires could have been prevented.

E. Heat Energy

187. The sun is a source of heat.

ACTIVITY

MATERIALS: magnifying glass, piece of paper

Using a magnifying glass, focus the rays of the sun on a piece of paper. The paper will be charred by the heat provided by the sun. Occasionally a curved fish bowl causes a fire by acting as a lens and focusing the rays of the sun.

188. Friction produces heat.

ACTIVITY A

Rub your hands together vigorously. They will soon become quite warm due to the friction between them.

ACTIVITY B

MATERIALS: hammer, nail, block of wood

Drive a nail into a block of wood and pull it out again. Feel the nail immediately. It will be quite warm because of the friction between the nail and the wood.

189. Electricity can be changed into heat.

ACTIVITY

MATERIALS: dry cell, wire

Connect the ends of a wire to the terminals of a dry cell. Feel the wire. It becomes hot as the electrical energy is converted to heat energy. Disconnect the wire immediately after detecting the heating effect.

190. Collision between two objects can produce heat.

ACTIVITY

MATERIALS: hammer, piece of iron

Strike a piece of iron several times with a hammer. The iron becomes warm because of the collision between the two objects.

191. The molecular motion of a substance is speeded by heating it.

ACTIVITY

MATERIALS: 2 jars, hot and cold water, soluble ink, eyedropper

Fill a jar with hot water and another jar with cold water. Allow the jars to stand for about a minute while motion of the water stops. Carefully put two drops of soluble ink into each jar. Do not stir. Mixing will be caused by the motion of the water molecules. What evidence do you observe indicating that water molecules are moving more rapidly in one jar than in the other?

192. As heat is added to a substance the molecules of that substance move more rapidly and its temperature rises.

ACTIVITY

MATERIALS: hot plate, Pyrex glass pan or beaker, water, thermometer, support, sawdust

Suspend a thermometer from a support into a Pyrex pan or beaker of cool water which is resting on a stove or hot plate. Turn on the heat and watch the thermometer as the heat passes into the water and the temperature rises. The increased motion of the molecules becomes most evident as the water begins to boil. The motion within the water can be observed better by adding a small amount of sawdust to it.

MATTER AND ENERGY

193. Heat causes most things to expand.

ACTIVITY A

MATERIALS: alcohol burner, flask, glass tube, one-hole rubber stopper, ring stand and ring, wire gauze

Insert a glass tube into a one-hole rubber stopper being careful to wet the tube and stopper and to protect your hands with several thicknesses of cloth. Fill a flask with water and fit the stopper in the flask in such a way that the water moves about halfway up the tube. Place a wire gauze on a ring attached to a ring stand, place the flask on the ring, and heat the water with the alcohol burner. As the water becomes hotter, it will expand and move up the tube. Cool the flask and the water will contract and move down the tube.

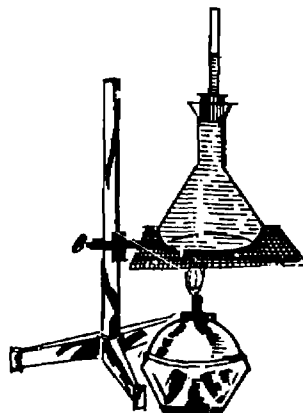

193 A

ACTIVITY B

MATERIALS: candle or gas burner, iron washer, iron bolt which just fits the washer, tongs, water

Slip the washer back and forth over the bolt. Hold the bolt with tongs and heat it in a candle or gas burner flame. Again try to slip the washer over the bolt. Because the heat has caused it to expand, the bolt will no longer fit through the washer. Dip the bolt into water and again slip it through the washer. The water cools the bolt and causes it to contract.

ACTIVITY C

MATERIALS: candle, support, metal weight, copper wire

Hang a weight from a support using a copper wire long enough to suspend the weight about one sixteenth of an inch from the table top. The weight should swing freely without hitting the table. Heat the wire with a candle

Heat Energy

until the weight touches the table and is no longer able to swing. Allow the wire to cool. The weight will no longer touch the table. The wire expands when heated and contracts when cool.

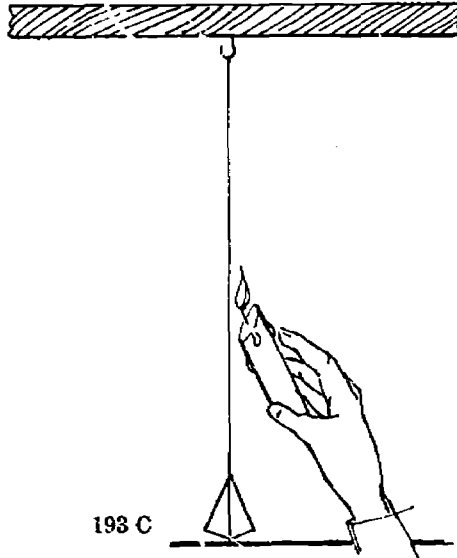

ACTIVITY D

MATERIALS: candle, 2 supports, metal weight, piece of copper wire

Extend a copper wire between two supports. Using another wire, hang a metal weight from the middle of the horizontal wire. Measure the distance from the table top to the suspended weight. Heat the horizontal copper wire with a candle and observe the distance from table to weight as the wire heats and then cools. The wire expands when heated and contracts when cooled.

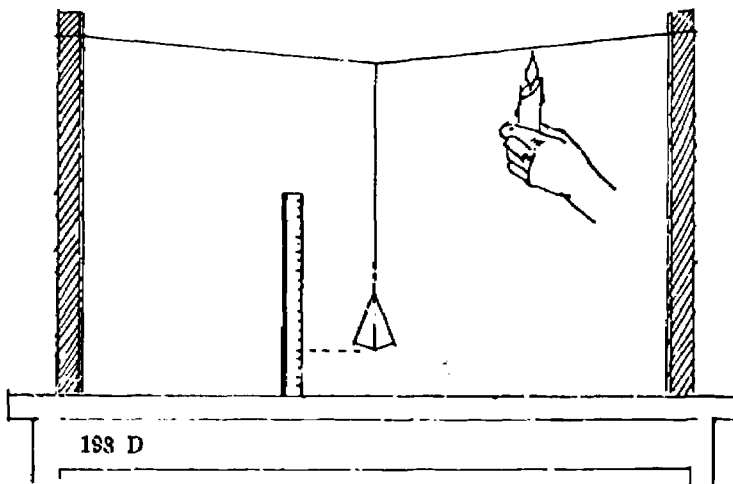

MATTER AND ENERGY

ACTIVITY E

MATERIALS: glass bottle, one-hole rubber stopper for bottle, glass tube (about 10"), glass tumbler, water

Put a glass tube into the hole of a one-hole stopper and put the stopper into the mouth of a glass bottle.

CAUTION: *When inserting the tube into the stopper, moisten both and wrap them in cloth to avoid being cut.*

Turn the bottle with the tube and stopper upside down and place the free end of the tube in a glass of water. Put both hands around the bottle to warm it. Watch the end of the tube for several minutes. Finally, remove your hands from around the jar, hold it only by the neck, and watch the tube which is immersed in the water. What conclusions can you draw concerning the effect of heat upon air?



193 E

ACTIVITY F

MATERIALS: Erlenmeyer flask, balloon

Fasten the open end of a balloon over the mouth of a flask. Place the flask on a hot radiator or warm it over a candle. Notice what happens to

Heat Energy

the balloon. Cool the flask. What happens to the balloon after the flask is cooled?

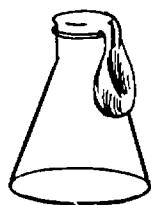

193 F

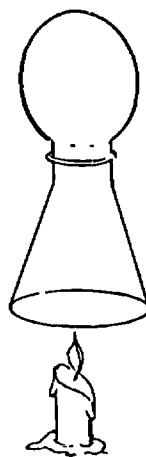

194. Evaporation of a liquid to a gas requires heat.

ACTIVITY A

MATERIALS: 2 paper towels, 2 plates, water, teaspoon

Put a paper towel on each of two plates. Pour a teaspoonful of water on each paper towel. Put the plates near each other on a table in front of a window, but place one in the sunlight and one in the shade. Look at them from time to time and see which towel becomes dry first. What reasons can you give for your observations?

ACTIVITY B

MATERIALS: water, rubbing alcohol, eyedropper

It is possible to detect the heat which is required to change a liquid to a gas through the sense of feeling. The more rapidly the liquid evaporates, the more rapidly it must take heat from its surroundings. Put about three drops of water on the back of your hand. Blow on it gently. Dry your hand and put about three drops of rubbing alcohol on the same spot. Blow on it gently. Explain all observations in terms of the relationship between heat and evaporation.

195. Thermometers are used to measure temperature.

ACTIVITY A

MATERIALS: thermometer

Use a thermometer to measure the temperature of a variety of things and a variety of places. Include the temperature in the classroom, outside the school, in a refrigerator, the temperature of ice, and as many others as possible. Record the temperatures and discuss the variations.

MATTER AND ENERGY

ACTIVITY B

MATERIALS: jar, water, food coloring, one-hole stopper to fit the jar, glass tube, rubber band

Show how a thermometer works by filling a jar with cold water. Color the water with food coloring. Fit a glass tube into a stopper so that the tube extends above the stopper. (See Appendix A, "Working With Glass Tubing.") Push the stopper into the jar which is filled to the brim so that some of the colored water moves up the tube. Mark the level of the water in the tube with a rubber band. Put the jar in a warm place and examine it after it has had an opportunity to become warmer. Notice that the level of the water rises. Cool the jar and the level will move down again.



195 B

196. Temperature can be measured on more than one type of thermometer.

ACTIVITY

MATERIALS: Fahrenheit thermometer, Celsius (centigrade) thermometer

Read the temperature of the room on both Fahrenheit and Celsius thermometers. Record these temperatures. Take the temperatures with both thermometers of as many other locations as possible, ranging from inside the refrigerator freezer to a hot boiler room. Record all these temperatures. Discuss the advantages and disadvantages of the two scales. Does it make any difference which one is used? How many Fahrenheit degrees equal one Celsius degree? How can the temperature reading on one scale be converted to the temperature reading on the other scale?

197. Heat travels through a solid by conduction.

ACTIVITY

MATERIALS: candle, nail

Light a candle. Holding one end of a nail, touch the other end to the flame of a candle. Soon the nail becomes too hot to hold. Heat is transferred along the nail by conduction.

Heat Energy

198. Some materials conduct heat more readily than others.

ACTIVITY

MATERIALS: candle, brass curtain rod, glass rod,
2 marbles, matches

Using melted wax from a candle, attach marbles five inches from the ends of a glass rod and a brass rod. Strengths of attachment should be equal. Place the ends of the two rods in a candle flame simultaneously. Explain what happens in terms of the capacity of materials to carry heat.

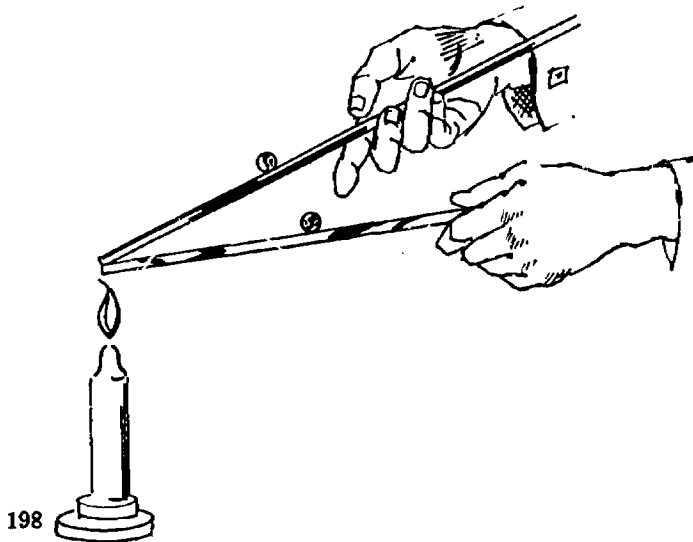

199. Metals are generally good conductors of heat.

ACTIVITY

MATERIALS: candle, wire screen, match, tongs

Light a candle and observe the flame. With tongs, lower a piece of wire screen into the flame. Notice that the flame does not noticeably rise above

MATTER AND ENERGY

the screen. Explain your observation in terms of the capacity of metals to conduct heat.

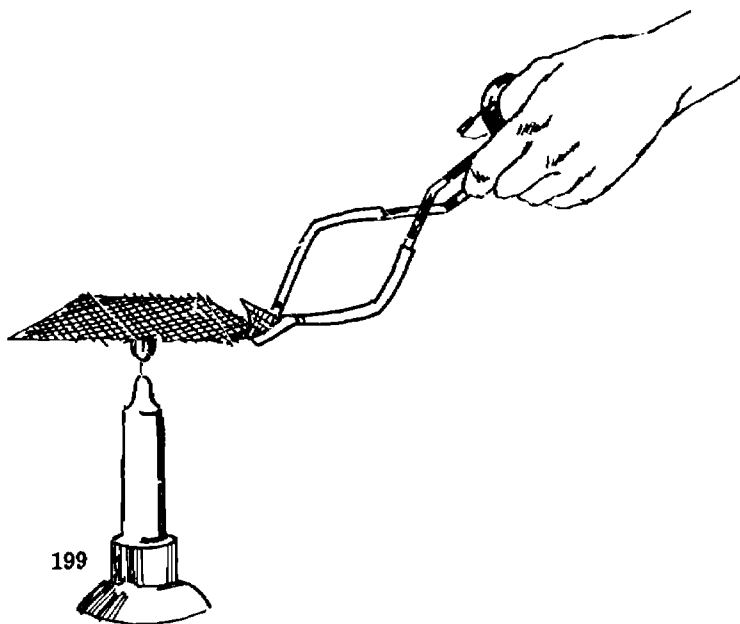

200. Metals vary in their capacity to conduct heat.

ACTIVITY

MATERIALS: candle or gas burner, pliers, several 10-inch wires of different metals, tacks

Using pliers, join wires of different metallic content together by twisting one end of each of the wires together. Spread the opposite ends apart. Using melted paraffin from a candle, attach a tack on the free end of each wire. Hold the twisted ends with pliers in the flame of a candle or gas burner and watch the tacks. All tacks do not drop off at the same time because the different metals vary in their capacity to conduct heat.

201. Some materials are poor conductors of heat.

ACTIVITY A

MATERIALS: candle or gas burner, test tube, water

Fill a test tube about three-fourths full of water. Hold the bottom of the test tube with your hand and heat the upper surface of the water in a candle flame or gas burner. It is possible to boil the water on the top while still holding the bottom. This is because water and glass are such poor conductors of heat.

ACTIVITY B

MATERIALS: wooden match, paper

Light a wooden match. Notice that it is possible to hold one end even though the other end is burning. Light a piece of paper. It is also possible to hold this paper even though a part of it is burning. This is because wood and paper are such poor conductors of heat.

Heat Energy

202. Heat can be transferred in a liquid by convection.

ACTIVITY

MATERIALS: gallon jar, small jar with cork, ink, water

Fill a gallon jar with cold water. Fill a small jar with warm water colored with ink. Cork the small jar lightly. Tie a piece of string around the cork, place it in the bottom of the large jar, and remove the cork by pulling on the string. Exercise caution to avoid disturbing the water. The movement of the warm colored water through the cold water illustrates how warm currents pass through a fluid.

203. Heat can be transferred in a gas by convection.

ACTIVITY

MATERIALS: lamp chimney, candle, wood splint, 2 blocks of wood

Place a lighted candle between two blocks of wood and rest a lamp chimney on the blocks and over the candle. Light a wood splint, blow it out so that it smokes, and place the smoking splint at the top and then at the bottom of the chimney. The path of the smoke illustrates how warm air moves out of the top of the chimney and cool air moves in the bottom. The air currents caused by heating the air are called convection currents.

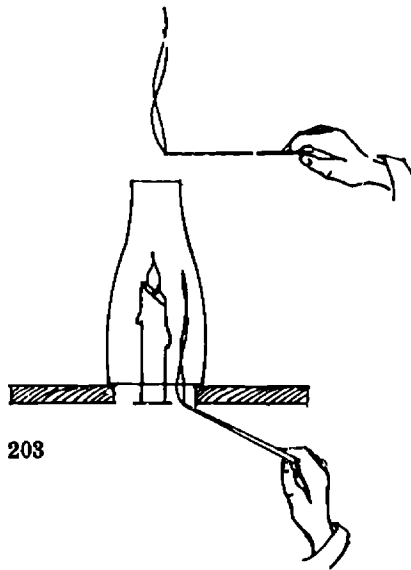

MATTER AND ENERGY

204. A warm liquid weighs less than an equal volume of the same liquid at a lower temperature.

ACTIVITY

MATERIALS: 4 glass quart-size milk bottles, soluble ink, hot plate, water, cardboard, pan

Heat two quarts of water, color the water with soluble ink, and pour it into two milk bottles. Fill two other milk bottles with cold water. Have one person cover the top of one of the bottles of hot water with a piece of cardboard while another person covers the top of a bottle of cold water. Invert the two covered bottles and place a hot one mouth to mouth on top of a cold one while placing a cold one on top of a hot one. Simultaneously remove the pieces of cardboard and observe what happens in each pair of bottles. Explain your observations in terms of the relative weights of hot and cold liquids.

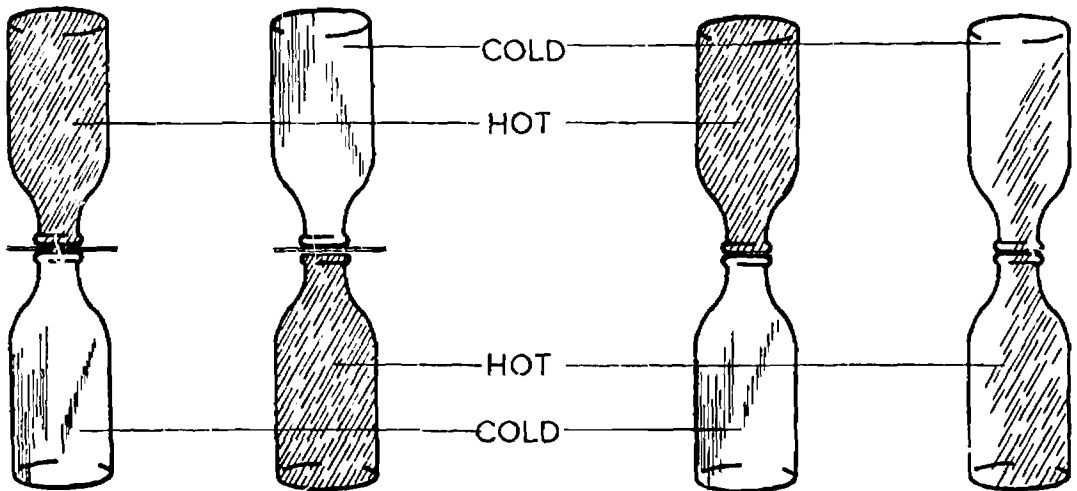

204

205. Heat can be transferred by radiation.

ACTIVITY

MATERIALS: candle, paraffin block, piece of metal

Light a candle and place a block of paraffin close beside it. The paraffin melts because heat reaches it by radiation. If a piece of metal is placed between the candle and the paraffin, the radiation of heat will be blocked and the paraffin will not melt.

206. Dark, dull objects radiate heat more readily than light, shiny objects.

ACTIVITY

MATERIALS: 2 identical cans, 2 thermometers, hot water, white paint, black paint

Paint a can black on the outside and another can white on the outside. Fill both cans with equal amounts of hot water and place a thermometer in each. Read the temperatures every five minutes for about a half hour. The water in the black can cools more rapidly than the water in the white can because dark objects radiate heat more readily than light objects.

Heat Energy

207. Dark, dull objects absorb heat more readily than light, shiny objects.

ACTIVITY A

MATERIALS: white paper, black paper, candle, lamp

From a candle, put a drop of wax on the center of a piece of white paper and a drop on a piece of black paper. After the wax has hardened, hold both sheets of paper six inches from a lighted electric light bulb. The wax on the black paper will melt before the wax on the white paper because the dark surface will absorb more heat from the bulb.

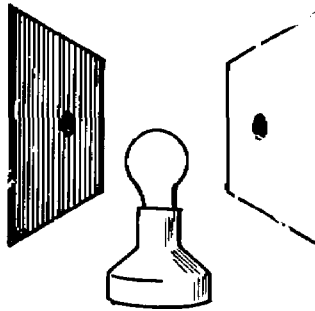

207 A

ACTIVITY B

MATERIALS: 2 identical cans, 2 thermometers, 2 pieces of cardboard, water, black paint, paint brush

The relationship between the color of an object and its capacity to absorb heat can be determined by painting a can black and leaving an identical can shiny. Fill both cans about three-fourths full of water taking care to measure identical amounts of water for both cans. Put a piece of cardboard over the top of each can and insert a thermometer into each can through a hole in the center of the cardboard. Put both cans in the sunlight and record the temperature of each every ten minutes. Explain your observations and the data you record in terms of the basic understanding given above.

ACTIVITY C

MATERIALS: can, black paint, candle, 2 coins

Paint one side of the inside of a can black while leaving the other side light. Using melted wax from a candle, attach two coins on the outside of the can placing one coin on the outside of the dark side and one on the out-

MATTER AND ENERGY

side of the light side. Stand a lighted candle in the center of the inside of the can. The coin will fall off the dark side of the can before the coin falls from the light side since the dark side absorbs heat more readily.

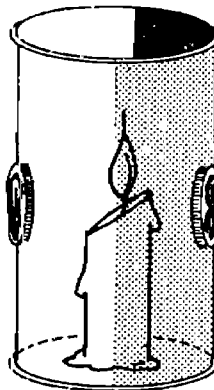

207 C

208. A thermostat is a device for automatically controlling temperature.

ACTIVITY A

MATERIALS: bimetallic strip, candle, match

Obtain a bimetallic strip from a source such as a science supply house. Such a strip is made of two metals bonded together that expand at different rates when heated. Hold the bimetallic strip over a candle and notice how it bends. Cool it and it will straighten out again. Discuss how this device would be useful in thermostats for controlling the switches of heaters and air conditioners.

ACTIVITY B

MATERIALS: thermostat, candle, match, ice

Obtain a used thermostat from the school janitor or from a heating contractor. Examine the inside carefully. Cool it by holding it near ice and then warm it by holding it near a lighted candle. Notice what changes take place with a change in temperature. These changes control the switches which can turn heating and cooling devices on and off.

209. Many engines gain their force from the expansion of heated gases.

ACTIVITY

MATERIALS: references

Have the children trace the history and development of heat engines and describe how each operated. Include such examples as Hero's engine, the many kinds of steam engines, diesel engines, gasoline engines, gas turbines, and solid and liquid fuel rockets.

F. Wave Energy

210. Energy can be transferred by waves.

ACTIVITY A

MATERIALS: 25-foot clothesline rope

Have a child hold one end of a piece of clothesline rope while you apply a quick up and down motion on the other end. Notice the waves traveling along the rope. Does the child feel the up and down motion? Continue to experiment using a variety of methods of input, including a variation in the speed and intensity of input movements. Observe and discuss your observations.

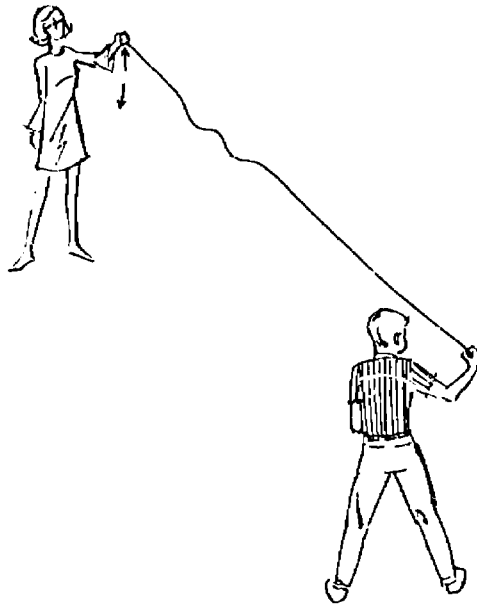

207 A

ACTIVITY B

MATERIALS: tub of water, stones

Drop a stone in a tub of water. Observe the waves produced. Notice the up and down motion. Notice how they spread farther and farther from the source. Float something in the water and notice how it is affected by the waves.

ACTIVITY C

MATERIALS: chalkboard, chalk, roller skates

Have a child put on roller skates and stand next to a chalkboard. Have the child draw up and down on the chalkboard with a piece of chalk. As he does, push him forward along the chalkboard. The combined horizontal motion of his body and vertical motion of his hand will produce a

MATTER AND ENERGY

wave. Label the parts of the wave: the crest, the trough, and the wavelength.

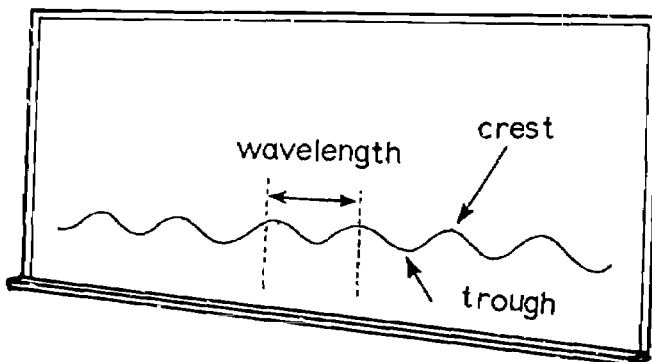

210 C

211. Reflection is a property of waves.

ACTIVITY A

MATERIALS: 20-foot clothesline rope

Tie one end of a clothesline rope to a firm support and hold the other end at a distance which allows it to sag slightly. Move the rope up and down with a sudden jerk sending a wave along it to the other end. Notice that the wave reflects or bounces from the other end and returns along the rope.

ACTIVITY B

MATERIALS: Slinky toy

Hold one end of a Slinky (a spring-like toy) and have someone hold the other end far enough away so that there is only a slight sag. Compress about two feet of this spring and then release the compression. Notice how the compression or wave travels along the spring, reflects or bounces from the other end, and returns along the spring.

ACTIVITY C

MATERIALS: transparent glass baking dish, water, overhead projector

Fill a transparent glass baking dish to a depth of about one inch with water and put it on an overhead projector. By dipping your finger in and out of the water at a point about three inches from one side of the dish, direct waves toward the side of the dish. Notice that when the waves hit the side they reflect or bounce back. The shadows of these waves can be projected on a wall or screen and viewed by the entire class.

212. Refraction, the bending of waves as they pass at an angle (other than 90°) from one medium to another, is a property of waves.

ACTIVITY A

MATERIALS: glass, water, pencil

Light waves are bent when they pass at an angle from a medium of one density to a medium of another density. To illustrate this, put a long

Wave Energy

pencil into a glass of water in such a way that only part of it is submerged and observe it from many angles. Note the variety of forms and shapes which the pencil appears to have. Explain your observations in terms of refraction of light.

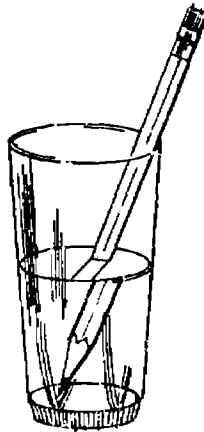

212 A

ACTIVITY B

MATERIALS: coffee cup, penny, water, glue

Light waves are bent when they pass at an angle from a medium of one density to a medium of another density. To illustrate this, glue a penny to the bottom of a coffee cup. Look into the cup at the penny and then back away until you barely lose sight of the penny over the edge of the cup. While holding your head still, have someone pour water into the cup. Explain your observations in terms of refraction of light.

213. Interference is a property of waves.

ACTIVITY

MATERIALS: transparent glass baking dish, water, overhead projector

Fill a transparent glass baking dish to a depth of about one inch with water and put it on an overhead projector. By dipping two fingers in and out of the water simultaneously, waves are set up which encounter one another. Look for evidence of where these waves reinforce one another in meeting and where they interfere with each other. The shadows of these waves can be projected on a wall or screen and viewed by the entire class.

214. Diffraction is a property of waves.

ACTIVITY

MATERIALS: transparent glass baking dish, water, 2 blocks of wood, overhead projector

Diffraction can be evidenced by the bending of waves around a corner. Place two blocks of wood about an eighth of an inch apart in a transparent glass baking dish. If necessary, place weights on the blocks to keep them from floating. Add about one inch of water and put the dish on an overhead projector so that any waves in the water will be projected on the wall. At one end of the opening between the blocks, dip your forefinger in and out of the water rapidly sending waves between the blocks. As the

MATTER AND ENERGY

waves emerge from this path, notice that they spread out on the other side of the blocks. This spreading around the corners of the blocks is evidence of diffraction.

215. Light appears to travel in a straight path.

ACTIVITY A

MATERIALS: cardboard, candle, match, scissors,
ruler, pencil

Cut out three pieces of cardboard 10" x 5". Fold each piece so that half of it can serve as a base on a table and half can stand upright. Punch a pencil point in the center of each upright portion and line them up with the wick of a candle. Light the candle and check again to see if you can see the flames through the holes. Now move the center cardboard a little to one side. Return it to its position in a straight line and move the others slightly. What can you conclude about the path in which light appears to travel?

ACTIVITY B

MATERIALS: candle, match, can, tissue paper, alumi-
num foil, pin, rubber bands, box camera

Remove both ends from a can. Cover one end with aluminum foil and the other end with tissue paper and hold them in place with rubber bands. Using a pin, punch a small hole in the center of the foil. Point the foil end toward a burning candle and look at the tissue paper on the other end. Why does the candle flame appear upside down? To illustrate this, draw a side view diagram of the can, the candle, and the image of the candle. Using straight lines to represent the path of light, show how the light from various parts of the candle flame travels through the pinhole to appear on the tissue paper as it does.

215 B

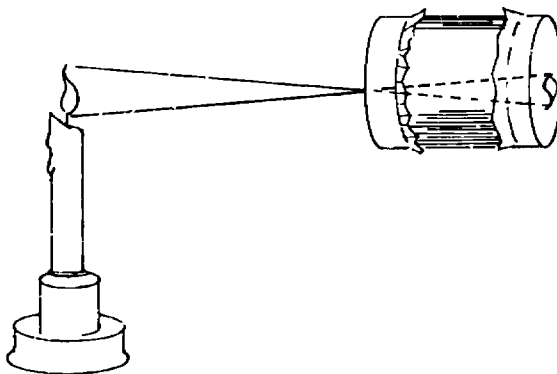

Wave Energy

216. Light exhibits the wave property of refraction.

ACTIVITY

MATERIALS: paper, pencil, sheet of glass

Draw a straight line on a piece of paper. Cover half of the line with a sheet of glass. View from a variety of angles the point at which the line emerges from under the glass. The apparent break in the line is the result of the bending of light as it travels at an angle from one medium to another.

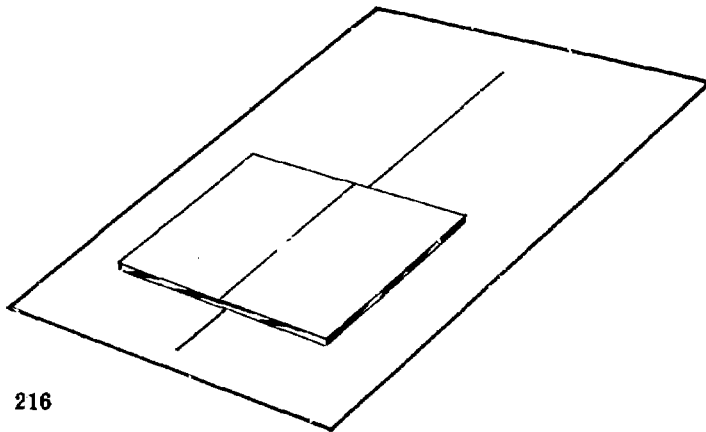

216

217. Light exhibits the wave property of interference.

ACTIVITY

Hold the first and second fingers of your right hand a few inches in front of your eye and look toward a source of light. Adjust the opening between your fingers until you appear to see dark lines between them. These apparent dark lines result from light waves converging in such a way as to interfere with one another and, as a result, cancel each other resulting in darkness.

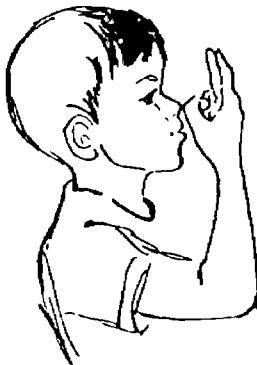

217

MATTER AND ENERGY

218. Light exhibits the wave property of diffraction.

ACTIVITY

Hold the first and second fingers on your right hand in front of your eye and look toward a light. Adjust the opening between your fingers until you appear to see dark lines between them. The lines are formed by wave interference which results from converging of waves which bend or diffract as they pass through the opening.

219. Light exhibits the wave property of reflection.

ACTIVITY

MATERIALS: mirror

Use a mirror to illustrate that light exhibits the wave property of reflection. Devise experiments in order to learn as much as you can about the way in which a mirror reflects light.

220. Opaque objects stop light rays and cast shadows.

ACTIVITY

MATERIALS: spotlight, sheet, rope

Hang a white bed sheet on a rope extended across the room. Point the spotlight toward the sheet and allow some of the children to do shadow plays between the light and the sheet while the rest of the children watch from the other side of the sheet.

221. When light strikes a surface, it is affected in different ways by different materials.

ACTIVITY

MATERIALS: clear glass, frosted glass, black paper, white paper, mirror

Examine each of the materials listed above. Notice how they affect light. The clear glass is called transparent since light passes through it, and objects on the other side can be seen clearly. The frosted glass is called translucent since light passes through it but shapes on the other side are not clearly distinguishable. The black paper is opaque because light will not pass through it. The scattered light reflecting from the white paper is called diffused light whereas clear images are reflected from the mirror.

222. Light exhibits the properties of particles when it activates a photoelectric cell.

ACTIVITY

MATERIALS: light meter

Examine a light meter. When light enters it, the light strikes a photoelectric cell. Electrons are emitted from the photoelectric cell and pass through a meter which registers with an indicator on the face of the meter. This is evidence for the particle nature of light since, theoretically, the light would have to behave like tiny particles in order to eject electrons and cause an electric current to flow.

Wave Energy

223. Visible light spans only a short segment of the overall spectrum of waves.

ACTIVITY

MATERIALS: chart of the electromagnetic wave spectrum

Locate an electromagnetic wave spectrum in an encyclopedia or reference book. Locate the position on the spectrum of visible light, ultraviolet light, infrared light, radio waves, radar, and other waves of interest.

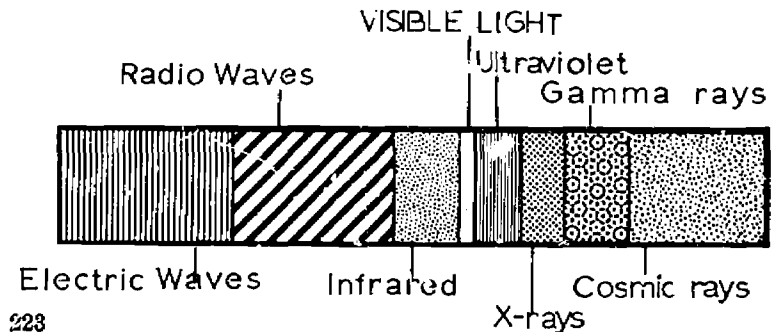

224. Light travels at a speed of about 186,000 miles per second.

ACTIVITY

MATERIALS: flashlight

Stand at one end of a dark room with a flashlight. Point the flashlight toward the opposite wall. As you push the button to turn the light on, watch the wall and estimate how long it takes for the light to reach the wall. Would you say that the light travels as fast as you can walk, as fast as you can run, as fast as a car, as fast as an airplane, or faster?

225. Man makes use of light from many sources.

ACTIVITY

MATERIALS: light sources, references

Have the children bring to school as many different types of light sources as they can locate. Have them also check in reference books and locate pictures of types of lighting which man has used over the ages.

226. Many different kinds of energy can be changed into light.

ACTIVITY

MATERIALS: light sources, references

Have the children locate actual devices or references about devices which illustrate how light can be produced directly from other energy sources such as electrical, heat, atomic, and chemical energy.

227. The incandescent light bulb was invented as a result of patient experimentation.

ACTIVITY

MATERIALS: references

Assign a report on Thomas Edison with an emphasis upon his efforts in the area of developing an incandescent light bulb.

228. Light waves may be reflected.

ACTIVITY

MATERIALS: rubber ball, floor, mirror

Attach a mirror to a wall. Stand about two feet from the wall and about two feet to the side of the mirror. Where must another person stand in

MATTER AND ENERGY

order to see you in the center of the mirror? To help better understand this, stand about ten feet from another person and throw a rubber ball back and forth by bouncing it on the floor. Repeat this several times comparing the angle at which the ball strikes the floor to the angle at which it bounces from the floor. The angle at which light enters a mirror is the same as the angle at which light waves reflect from the mirror.

229. Light is reflected from a plane mirror at the same angle that it enters the mirror.

ACTIVITY

MATERIALS: plane mirror, paper, pencil, ruler, protractor

Draw a broken line on a piece of paper and then draw a solid line at an angle from it. Stand a plane mirror upright at the point where the two lines meet. Looking straight along the dotted line, turn the mirror until the reflection of the dotted line is in line with the real dotted line. Line up your ruler with the reflection of the solid line and draw a line along the ruler. Measure the angles of the solid lines on each side of the broken line. Repeat the experiment several times using a variety of angle sizes. The angle of reflection should always equal the angle of incidence.

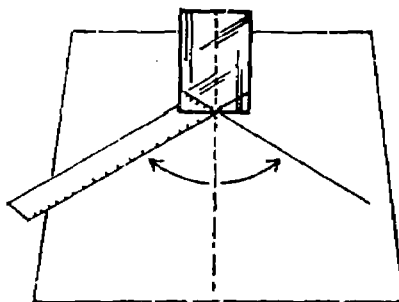

229

230. The curvature of the face of a mirror affects the type of image reflected by the mirror.

ACTIVITY

MATERIALS: plane mirror, concave mirror (shaving mirror), convex mirror (some automobile rear view mirrors)

Look at yourself in a flat mirror (plane), a mirror which curves inward (concave), and a mirror which curves outward (convex). How do the images of yourself vary? Experiment with these mirrors to determine what can be learned about them.

231. Light is refracted or bent when it passes at an angle (other than 90°) from one medium to another.

ACTIVITY

MATERIALS: handbook of chemistry and physics, materials which refract light

Locate in a chemistry and physics handbook a table which lists the index of refraction for several materials. The higher the index of refraction, the more the material is capable of bending light. Collect as many of the listed materials as you can and devise experiments to compare their abilities to bend light.

Wave Energy

- 232. The human eye contains a flexible, adjustable lens.**

ACTIVITY

MATERIALS: cow eye

Obtain a cow eye from a slaughterhouse. Dissect it and examine the lens.

- 233. The lens in a camera focuses an image on the film.**

ACTIVITY

MATERIALS: box camera, translucent tissue paper

Open a box camera, point it toward a very bright object, and hold a piece of translucent tissue paper where the film would normally be. Notice the image which is formed on the tissue paper.

- 234. Lenses are used in a wide variety of optical instruments.**

ACTIVITY

MATERIALS: optical instruments

Have the children bring to school and display all of the types of devices which they can locate which contain lenses. Glasses, binoculars, telescopes, cameras, and microscopes are but a few examples.

- 235. All colors are present in white light.**

ACTIVITY A

MATERIALS: rectangular baking pan, water, pocket mirror

Set a pan of water in a position where the sunlight entering a window strikes it. Lean a small pocket mirror on the inside of the pan and adjust its angle until a spectrum of colors is reflected on the wall or ceiling.

ACTIVITY B

MATERIALS: prism

Darken a room and allow a ray of sunlight to enter. Hold a prism in the ray of sunlight and rotate it until it projects a rainbow on the wall. Notice that the prism divides the white sunlight into red, orange, yellow, green, blue, indigo, and violet.

- 236. Colored lights combine to produce other colors.**

ACTIVITY

MATERIALS: slide or overhead projector, screen or white wall, colored cellophane

Darken the room and project white light from a slide or overhead projector on to a screen. Place individual and various combinations of colored cellophane in front of the projector and note the colors produced by various combinations of colored light.

- 237. Colored pigments combine to produce the other colors.**

ACTIVITY

MATERIALS: variety of watercolor paints

Mix various colors of paint and note the colors which are produced by the mixture.

- 238. Sound is produced by vibrating objects.**

ACTIVITY A

MATERIALS: ruler

Hold one end of a ruler tightly against the top of a table leaving the other end projecting over the edge. Hold the projecting end down, release it

MATTER AND ENERGY

suddenly, and note the sound produced. Repeat the experiment using different lengths of the ruler. What conclusions can you draw?

ACTIVITY B

MATERIALS: tuning fork, glass of water

Strike a tuning fork and hold it close to your ear. Listen to the humming. Can you detect the prongs vibrating? Touch the prongs and stop the vibration. Strike the tuning fork again and touch it lightly to the edge of a glass. Strike it again and dip it into some water. The fact that the prongs are vibrating becomes obvious from the tapping on the edge of the glass and the splashing of the water.

ACTIVITY C

MATERIALS: large can, sand, pencil

Produce a sound by tapping on the bottom of an empty can. To determine whether or not the can is vibrating, sprinkle grains of sand over the bottom of the can and tap again. As the can vibrates the grains of sand will bounce up and down.

ACTIVITY D

MATERIALS: needle, tagboard, phonograph, old phonograph record, masking tape, scissors

Fold a piece of 3" x 3" tagboard twice to form a piece which is 1" x 3" and push a needle through it. Hold the needle in the groove of an old phonograph record as it moves on a turntable and listen carefully to the sound produced. Next, roll a large sheet of tagboard into the cone shape of a megaphone, and use masking tape to hold it together. Tape the tagboard with the needle in it to the small end of the megaphone and hold the needle into the groove of the record again. Contrast the sound produced with the megaphone to the sound produced without the megaphone.

239. Sound travels as a wave.

ACTIVITY

MATERIALS: Slinky toy

Obtain a Slinky, a springlike toy available at most toy stores. Have two children take the ends of the Slinky and stretch it several feet between them. Press about ten loops of the spring together and release them suddenly. Notice how the wave travels along the spring. Continue to experiment, observe, and discuss your observations.



Wave Energy

240. Sound exhibits the wave property of reflection.

ACTIVITY

An echo is an example of the reflection of sound. Locate a place within a large room, near a big building, or near a mountainside where an echo of your voice can be heard.

241. Sound exhibits the wave property of refraction.

ACTIVITY

MATERIALS: balloon, clock which ticks

Blow up a balloon with carbon dioxide gas. The carbon dioxide can be produced by pouring vinegar on baking soda. Hold it between your ear and a ticking clock and adjust the distances until the clock can be heard clearly. Without moving either your ear or the clock, remove the balloon from between them. Notice that the clock cannot be heard as clearly as before. The balloon serves as a lens which refracts the sound and focuses it on the ear.

242. Sound exhibits the wave property of interference.

ACTIVITY

MATERIALS: 2 identical tuning forks mounted on resonator boxes, adjustable weight for one of the tuning forks, rubber hammer

Strike the two tuning forks so that they sound separately and then together. Note the clear steady sound which is heard. Next, attach an adjustable weight to one of the forks and listen to the two forks simultaneously. Adjust the weight to various positions and repeat until a definite throbbing is heard in the sound. This variation is due to interference. If the waves from the two forks coincide when they meet, the sound becomes louder. If the two waves do not coincide when they meet, they cancel one another and the intensity of the sound goes down.

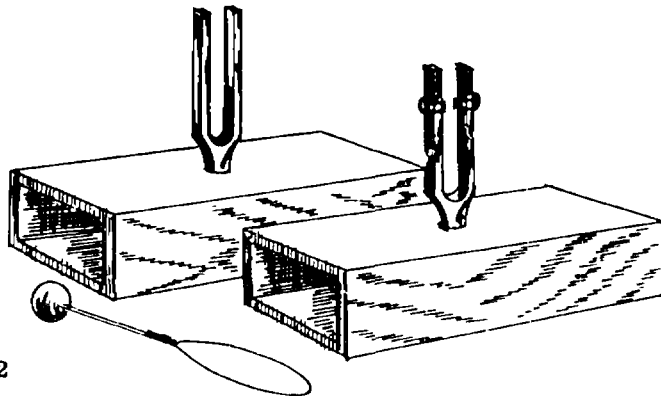

242

MATTER AND ENERGY

- 243. Sound exhibits the wave property of diffraction.**

ACTIVITY

Diffraction is exhibited when a wave travels around a corner. Have one of the children go out in the hall where he cannot be seen. Leave the door open. Have him speak or make a sound. If the children inside the room can hear the sound, then it must have bent around a corner thus demonstrating diffraction.

- 244. Sound passes through a substance by molecules striking and passing on the sound energy to other molecules.**

ACTIVITY

MATERIALS: ruler with arched groove, 6 marbles

To illustrate how sound is transmitted by the molecules of the materials which carry it, spread five marbles along the groove in a ruler. Roll a sixth marble into the groove on one end and note how the energy is transmitted along the ruler.

- 245. Sound is carried better by some materials than by others.**

ACTIVITY

MATERIALS: metal rod or pipe, table, pencil

Put your ear near one end of a table surface while a friend taps on the other end with a pencil. Then place your ear on the table while the tapping continues. Repeat the same procedure with a metal pipe or rod in place of the table. Compare the capacity of air and solids for carrying sound.

- 246. Sound travels through air at a speed of about 1100 feet per second.**

ACTIVITY

MATERIALS: 2 blocks of wood

Take the children to the school playground. Have one child move to one end of the school ground with two blocks of wood while the rest of the class moves to the other end of the school ground in a position where they can still see the lone child. Have the child strike the blocks of wood together. The rest of the class should watch and listen. The blocks will be seen striking before the sound is heard indicating that light travels faster than sound.

- 247. The pitch of a sound can be altered by adjusting the source of the sound.**

ACTIVITY A

MATERIALS: string, rubber band

Tie a string about a foot long to a firm, stationary object. Pull on the other end with one hand and pluck the string with a finger of your other hand. Vary the tension of the string while you pluck it and note the variation in the pitch of the sound produced. Repeat the experiment with a rubber band. What relationship do you note between the tension of the string and the pitch of the sound produced?

ACTIVITY B

MATERIALS: paper soda straw, scissors

Cut two notches on opposite sides on the end of a soda straw in such a way as to produce two points on the end of the straw. Flatten the cut end, with points together. Put the pointed end in your mouth and blow until you have learned how to produce a sound. Note the pitch of the sound. Cut about an inch from the other end of the straw, blow again, and note the pitch. Continue to cut and blow and note the results. How does the length of the air column relate to the pitch of the sound produced?

Wave Energy

248. The loudness of a sound depends upon the size of the vibrations of the object producing the sound.

ACTIVITY A

MATERIALS: ruler

Hold one end of a ruler firmly on the edge of a table with the other end extending out from the table. Push down lightly on the free end and release it while you listen to the sound which is produced. Repeat several times by bending the ruler a little more each time. Notice that the farther the ruler vibrates, the louder the sound becomes.

ACTIVITY B

MATERIALS: rubber band

Stretch a rubber band between the thumb and a finger of one hand. Pluck it lightly and listen to the sound produced. Pluck it several more times pulling on the rubber band progressively harder each time and notice that the intensity of the sound increases with an increase in amplitude of vibration.

249. Some sounds are more pleasant to hear than others.

ACTIVITY

MATERIALS: musical instruments, cans, paper

The quality of a sound depends upon the vibration pattern. Have children play a musical instrument play sounds which are pleasant to the ear. Contrast these sounds with the crumpling of paper and the rattling of cans. Have the children suggest other sounds which they consider pleasant and sounds which they consider unpleasant.

250. The quality of a musical tone is the property of that tone which is due to the combination of waves which produces it.

ACTIVITY A

MATERIALS: variety of musical instruments

Have several children bring their musical instruments to class. Choose a note from the musical scale and one at a time have each instrument sound that note. Although the note is identical in each case, it is possible to detect the difference between instruments. This is due to the fact that the quality of the sound is unique in each case.

ACTIVITY B

MATERIALS: piano

Strike a note on the piano. Have several children sing the same note. Even though the note may be identical in each case, it is possible to distinguish between voices because of the unique quality of each.

251. Music is a pleasant grouping of sounds.

ACTIVITY

MATERIALS: 8 identical bottles, spoon, water

Place eight identical bottles in a line. Leave the first bottle empty and add water to the others in varying amounts so that as you strike them with a spoon they will produce all of the notes on a musical scale. Play a tune. Can you make any other kind of a musical instrument?

MATTER AND ENERGY

- 252. A band and orchestra are made up of a wide variety of musical instruments each of which provides a unique function.**

ACTIVITY

MATERIALS: variety of musical instruments

Have the children who play musical instruments show how the sound is made, demonstrate the range of sounds which each instrument can produce, and describe the instrument's most important functions in a band, orchestra, or as a solo instrument.

- 253. The ear is the body's receiver of sound.**

ACTIVITY A

Invite a public health nurse or the school nurse to visit the class and discuss proper ear care.

ACTIVITY B

MATERIALS: model of ear, references

Examine a model of the ear (available in most high school biology departments) to see the various parts which make up an ear. Consult references to learn the names of these parts and the function which each performs.

- 254. The human voice is produced by vibrations of the vocal cords within the larynx.**

ACTIVITY

The larynx or "Adam's apple" is located in the throat. Hold your hand on your throat in the vicinity of the larynx. As you talk, feel the vibrations in your throat.

- 255. The change in the pitch of a sound as the source of the sound and the listener are moving in relation to one another is called the Doppler effect.**

ACTIVITY

MATERIALS: car

While you are standing along the side of a straight segment of highway, have someone drive by with the car horn sounding. Notice that the pitch of the sound changes as the car approaches and passes. Describe the change and the reasons for this change.

- 256. An airplane traveling at supersonic speed of sound produces a powerful compression wave that moves out from it and causes a loud explosive sound called a sonic boom.**

ACTIVITY

MATERIALS: tub of water, pencil

Dip the end of a pencil into a tub of water and move it slowly through the water across the tub. Observe the waves which are produced. Repeat the experiment several times moving the pencil faster each time. Observation of the waves produced should give an insight into the reason for a sonic boom.

Mechanical Energy

G. Mechanical Energy

257. Machines help us in many ways to do our work.

ACTIVITY

MATERIALS: magazines, scissors, paper, crayons

Have the children search their homes and neighborhood for examples of machines which help them. Prepare a bulletin board about these different machines by using pictures cut from magazines and pictures which the children draw.

258. A lever is a simple machine consisting of a rigid bar that is free to turn about a fixed point called the fulcrum.

ACTIVITY

MATERIALS: ruler, pencil, modeling clay

Rest a ruler on a pencil at the six inch mark. Place a lump of modeling clay on the twelve inch mark and push down on the other end, raising the clay. Move the pencil to different positions under the ruler and push on the end to raise the clay each time. Notice the effort needed to lift the clay each time and the distance which your finger moves compared to the distance that the clay moves. Can you detect any generalizations which seem to govern the operation of a lever.

259. A first class lever is one which has the fulcrum between the applied force and the resistance weight.

ACTIVITY

MATERIALS: triangular block of wood, stone, yardstick

Place a yardstick across and resting on one edge of a wedge-shaped block of wood. Put a stone on one end of the yardstick and lift it by pushing down on the other end. The yardstick is a first class lever since the fulcrum is between the weight and the applied force. Identify and discuss common examples of first class levers.

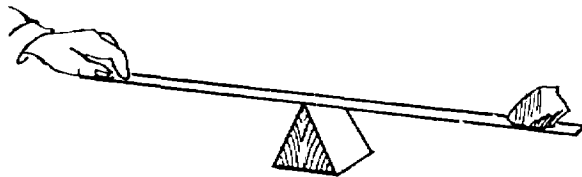

259

260. A second class lever is one which has the resistance weight between the applied force and the fulcrum.

ACTIVITY

MATERIALS: triangular block of wood, stone, yardstick

Place one end of a yardstick on an edge of a wedge-shaped block of wood. Put a stone on the center of the yardstick and raise it by lifting up on the free end of the yardstick. The yardstick is a second class lever since the

MATTER AND ENERGY

resistance weight is between the fulcrum and the applied force. Identify and discuss common examples of second class levers.

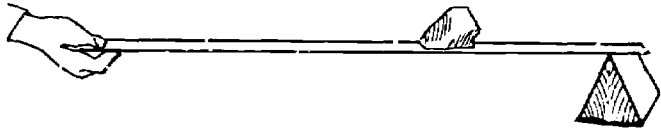

260

261. A third class lever is one on which the force is applied between the fulcrum and the resistance weight.

ACTIVITY

MATERIALS: triangular block of wood, stone, yardstick

Place one end of a yardstick on an edge of a triangular block of wood and hold it in place with one hand. Put a stone on the other end. Lift the yardstick by applying an upward force in the center of the yardstick. The yardstick is a third class lever since the applied force is between the fulcrum and the resistance weight. Identify and discuss common examples of third class levers.

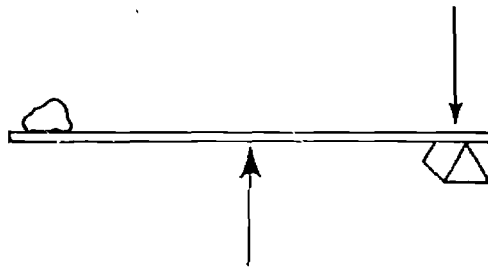

261

262. An inclined plane is a simple machine consisting of a slanted surface.

ACTIVITY

MATERIALS: two-foot board, books, yardstick, string, rubber band

Tie a string around a book and attach a rubber band to it. Holding the rubber band, lift the book and measure the length of the rubber band. Now place the board with one end raised by resting it on two books. Holding the rubber band, slide the tied book up the board and measure the length of the rubber band as it moves. Repeat sliding the book up the board with different number of books holding up the end of the board. Measure the length of the rubber band each time. Is an inclined plane helpful for moving heavy objects? Is it easier to move the objects when the inclined plane is steep or not so steep?

262

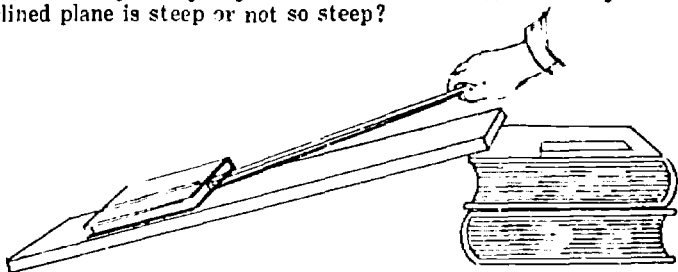

Mechanical Energy

243. A pulley is a simple machine consisting of a grooved wheel that is used to change the direction of a force or, in combination, to multiply a force.

ACTIVITY

MATERIALS: pulley, string, rubber band, book, ruler

Tie a string around a book and attach a rubber band to the string. Grasping the rubber band, lift the book and measure the length of the rubber band while lifting. Remove the rubber band from the string and attach the string on the book to the support frame of a pulley. Pass a string through the wheel of the pulley and tie one end to a fixed support and a rubber band to the other end. Grasping the rubber band, pull on the string and lift the book which is hanging from the pulley. Measure the length of the rubber band as the book is being raised. Compare the length of the rubber band measured while raising the book by the two methods. Is there any advantage to using a pulley?

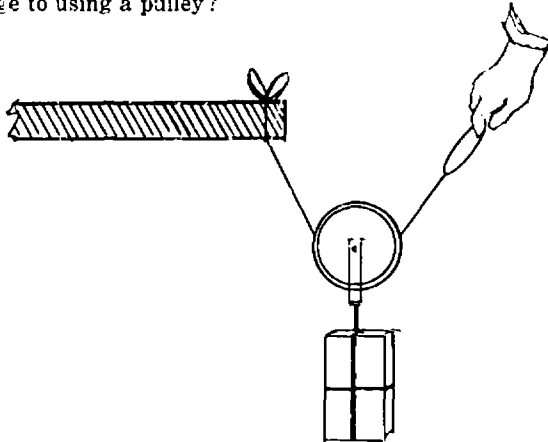

263

264. Simple machines may be combined into a complex machine.

ACTIVITY A

MATERIALS: toy block wagon, toy blocks, two-foot board, rubber band, books, string, ruler

To determine the combined effect of two simple machines, fill a block wagon with blocks. Attach a rubber band to the wagon, and grasping the rubber band, lift the wagon to the top of a stack of three books. Measure the length of the rubber band as you lift. Place one end of a board on the stack of books and remove the wheels from the wagon or turn the wagon over and stack the blocks on the bottom. Grasping the rubber band, slide the wagon up the board. Measure the length of the rubber band as it moves. Put the wheels back on the wagon and, grasping the rubber band, pull the wagon up the inclined board. Measure the length of the rubber band as it moves. Compare the three measurements. Do the wheels and inclined plane assist in lifting a heavy load?

ACTIVITY B

MATERIALS: examples of compound machines

Examine a machine which combines a variety of simple machines. Identify these individual simple machines and see how they combine to accomplish a particular task. An old clock is an example which can be used if access to a larger machine is not convenient.

MATTER AND ENERGY

265. Machines can be used to increase force, increase speed, and change the direction of a force.

ACTIVITY

MATERIALS: triangular block of wood, stone, yardstick

Place a yardstick on one edge of a triangular block of wood. Put a stone on one end of the yardstick and push down on the other. The yardstick now becomes a lever. By adjusting the position of the triangular block of wood, demonstrate how this machine can do the three things listed in the above statement.

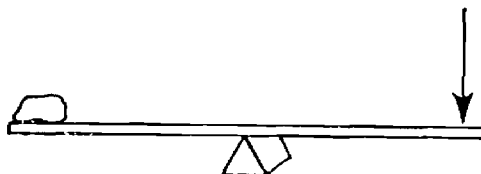

265

266. Machines can help us by increasing force.

ACTIVITY

MATERIALS: board (5 feet long or longer), brick

Place a board on a brick with the brick close to one end. Have the biggest boy in the class sit on the short end of the board and have the smallest girl in the class lift him by pushing down on the long end of the board. The board is acting as a lever.

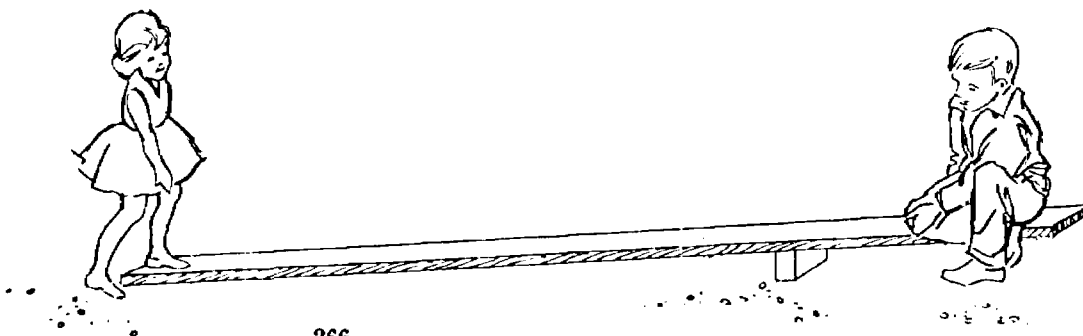

266

267. Machines can help us by changing the direction of a force.

ACTIVITY

MATERIALS: pulley, rope, weight

Suspend a pulley from a high place that the children cannot reach. Discuss with them the best way to lift a weight to that height. Show them that by pulling down on a rope over the pulley, the weight moves up.

268. Machines can help us by changing the speed and distance of a force.

ACTIVITY

MATERIALS: ruler, 2 erasers

Place an eraser under a ruler two inches from one end and ten inches from the other. Place another eraser on the end of the long arm of the

Mechanical Energy

lever. Strike the short arm sharply with your hand. Notice the speed and distance which the end of the long arm travels. Notice the speed at which the eraser flies from the ruler.

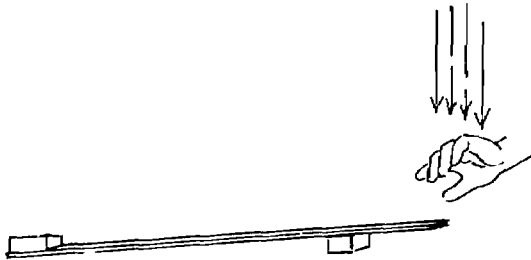

268

269. Work is performed when a force is moved over a distance.

ACTIVITY

MATERIALS: chair, coin

Have one child hold up a chair and stand perfectly still. During the time that the first child is standing still, have the second child flip a coin. Ask the class which child they think is doing the most work. Since the scientific definition of work is the movement of a force over a distance, if the child holding the chair does not move, he is not doing any work. The child flipping the coin is doing more physical work.

270. A foot-pound of work is a force of one pound acting over a distance of one foot.

ACTIVITY A

MATERIALS: pound weight (a pound of sugar or flour will do), foot ruler

To illustrate a foot-pound of work, stand a foot-long ruler on end and lift a pound weight from the bottom to the top. Proceed to demonstrate other amounts of work. For example, if a one-pound weight is moved two feet, two foot-pounds of work are accomplished. If a five-pound weight is moved two feet, the amount of work is five times two, or ten foot-pounds.

ACTIVITY B

MATERIALS: ladder, yardstick

Determine how much work is done in climbing to the top of a ladder. Measure the height of the ladder. Have a boy climb to the top. The work done in foot-pounds is calculated by multiplying the weight of the boy times the height of the ladder.

271. There is friction when one thing rubs against another.

ACTIVITY

MATERIALS: small wheel or an axle, toy block

When there is friction between two moving objects, heat is produced—the more friction, the more heat. Rub your hands together, back and forth, ten times and notice how warm they become. Rub a toy block against your hand ten times and note the heat, if any, which is produced. Finally, roll a wheel back and forth over your hand ten times. What is the advantage of a wheel over sliding objects?

MATTER AND ENERGY

- 272. Friction between two surfaces depends upon the materials on the surfaces.**

ACTIVITY

MATERIALS: two-foot board, block of wood, variety of materials (cloth, rubber, sandpaper, etc.), yardstick, rubber cement

Place a block of wood on a board and lift one end of the board until the block begins to slide. Measure and record the height of the board when sliding began. One at a time, attach several surfaces on the block of wood with rubber cement and repeat the experiment for each surface. The higher the board has to be raised to cause the block to slide, the greater the friction is on the surface being used. List the materials in order of the friction which they produce.

- 273. Friction is useful in controlling motion.**

ACTIVITY

MATERIALS: car

Arrange for one of the teachers or a mechanic from a nearby garage to remove the wheel from a car and demonstrate how friction is used in the brake mechanism for stopping a car.

- 274. Friction can be reduced in many ways.**

ACTIVITY

MATERIALS: small toy truck, toy blocks, rubber band, yardstick

To show the importance of wheels, fill a toy truck with blocks. Fasten a rubber band on the front of the truck and pull on the rubber band until the truck starts to move. Use the yardstick to measure the length that the rubber band stretches before the truck moves. Remove the wheels from the truck or turn the truck over and load all of the blocks on the bottom. Pull the rubber band until the truck begins to move, and measure the length of the rubber band as it is set into motion. Compare and discuss the two procedures.

- 275. The efficiency of a machine is a measurement of the portion of the work applied to the machine which the machine converts to useful work.**

ACTIVITY

MATERIALS: books, board (about 3 feet long), brick, spring balance, yardstick

Stack several books about two feet high. Weigh a brick and determine the amount of work required to lift the brick to the top of the stack of books. ($\text{Work} = \text{force} \times \text{distance}$). Make an inclined plane by leaning a board against the stack of books. Slide the brick up the inclined plane to the top of the books. Use a spring balance to measure the force required to slide the brick up the board. Measure the length of the board with a yardstick. Determine the work done when using the inclined plane. The efficiency of the inclined plane can be calculated by dividing the work done to lift the brick straight up by the work done in using the inclined plane and multiplying by 100. The value calculated is the percent of work put into the machine which is actually gotten out of it in useful work.

- 276. Motion is going on all around us.**

ACTIVITY

List everything around you which moves or must be moved in order to be of use.

Mechanical Energy

277. Motion is produced by a force on an object.

ACTIVITY

Ask the children to examine objects around them that move and determine what causes the motion. In each case some sort of force must be applied. List the things such as motors, gasoline engines, wind, themselves, etc., which apply these forces.

278. Motion can be described in terms of speed.

ACTIVITY

Take the class out to the school playground or track. Have two of the boys race across a set distance. Ask the children which boy ran with the greater speed. How do they know? Ask the children to describe how fast each boy ran. Eventually, they should broaden their concept of speed to describe it in terms of distance and time. Repeat the experiment and make the measurements necessary to determine the speeds of the running boys.

279. Modern vehicles increase transportation speeds.

ACTIVITY

MATERIALS: magazines, scissor paper, crayons, bulletin board

Have the children either draw or cut from magazines pictures representing as many examples of transportation as they can find. These can range from a person walking to a rocket speeding into space. Arrange these pictures on a chart or bulletin board in order of speed of motion. If possible, have the children consult books or inquire concerning the approximate speed of each of these methods. These speeds can be included in the display.

280. Speed is measured in terms of distance and time.

ACTIVITY A

MATERIALS: clock

Take the children to the school playground and line them up for a type of race. Tell them that when you say "go" they are to move forward by bringing the heel of one shoe to the toe of the other shoe. They are to continue moving forward in this manner as you time them for one minute at which time you will tell them to stop. As they move forward, they are to count the number of "steps" they take.

Time them moving forward for one minute and then compare their speeds in "steps per minute." Discuss the fact that the steps are of different lengths and therefore, in one respect, are not units which can be used for comparison.

ACTIVITY B

MATERIALS: automobile speedometer, map

Have the children investigate the ways in which speed is measured. The extent to which they can go in this activity is limited only by their understanding and imagination. Perhaps the simplest discussions can center around an automobile speedometer. Once they have discovered that this instrument measures speed in miles per hour, an effort can be made to interpret this measurement to them. For example, if a particular town which the children are familiar with is forty miles away, discuss the fact that it takes one hour to get there if a car travels at forty miles an hour. This activity can be expanded to using maps, discussing the high speeds of airplanes, the need for very high speeds in space flight, the use of units such as the knot, etc.

MATTER AND ENERGY

281. Changes in the speed of motion are described as acceleration.

ACTIVITY

Take the class to the school playground and have the children watch while you demonstrate acceleration with one boy. Tell the boy that as you start counting, he should begin moving slowly and gradually increase his speed so that by the time you count to five, he should be running at top speed. After demonstrating this, call him back and this time have him wait until the count of ten to reach full speed. Have the children discuss the differences in these two examples of increasing speed and develop a concept of acceleration.

282. A liquid which is free to flow seeks a level position.

ACTIVITY

MATERIALS: 2 glass funnels, 2 feet of rubber or plastic tubing, water

Connect the stems of two funnels with flexible tubing. Hold the funnels level with one another and pour water into them until they are both about half full. Raise and lower the funnels beside one another and notice how the liquid always flows toward a level position.

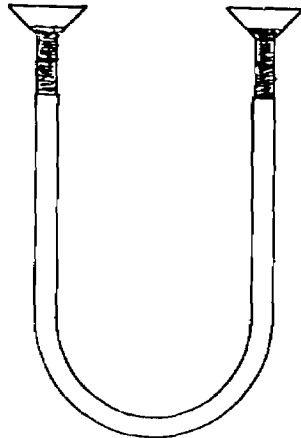

282

283. Liquids cannot be compressed.

ACTIVITY

MATERIALS: soft drink or milk bottle, one-hole stopper which fits the bottle, glass tube

Put a piece of glass tubing in a one-hole stopper so that the tubing is extending upward. (See Appendix A, "Working With Glass Tubing.") Fill a bottle with water and put the stopper in the bottle, forcing it in so that some of the water moves up the tube. Wrapping both hands around the

Mechanical Energy

bottle, squeeze it and note the rise in the liquid level in the tube. The glass container is compressed slightly but the liquid is not compressed.

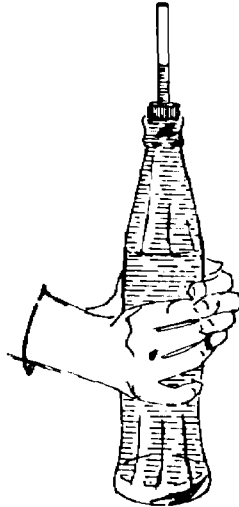

283

284. The molecules on the surface of a liquid cling together producing surface tension.

ACTIVITY

MATERIALS: glass of water, coins or small pebbles

Fill a glass to the brim with water. Drop coins or small pebbles, one at a time and edgewise, into the water. Notice how the water rises and bulges above the top of the glass. This is possible because of surface tension.

285. Pressure within a liquid increases with depth.

ACTIVITY

MATERIALS: tall metal can, nail, hammer, water

Using a nail and a hammer, punch three holes in a vertical line in the side of a tall can. Place one about one-fourth of the way from the bottom, another about one-half the way up, and a third three-fourths of the way up from the bottom. Place a finger over each hole, fill the can with water, and then remove all three fingers. The force with which the water spurts from the three holes indicates that the pressure increases with depth.

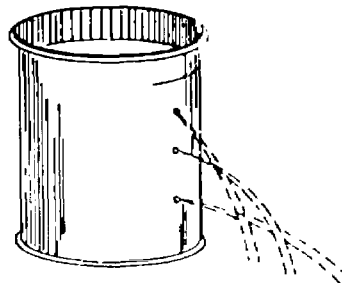

285

MATTER AND ENERGY

286. The pressure applied on a confined liquid is transferred equally and undiminished in every direction throughout the liquid.

ACTIVITY

MATERIALS: hot-water bottle, rubber tubing, funnel, books, water, pitcher

Attach a funnel to a hot-water bottle with about two feet of rubber tubing. Put three or four books on the hot-water bottle. Hold a funnel about a foot above the table and pour water into it. The books will be lifted from the table as the hot-water bottle fills. The weight of the water in the tube is transferred throughout the liquid and acts on every area within the water bottle equal to the cross-section area of the tube.

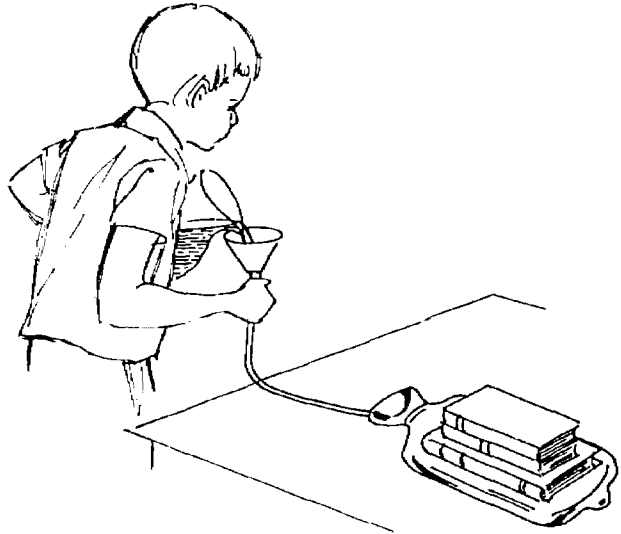

286

287. As air moving across a surface is speeded up, the pressure on the surface becomes less.

ACTIVITY A

MATERIALS: paper

Cut a strip of paper about two inches wide and eight inches long. Hold it by one end under your lower lip and blow gently over the top. The paper rises since the air moving rapidly over the top causes a reduction in air pressure above the paper strip.

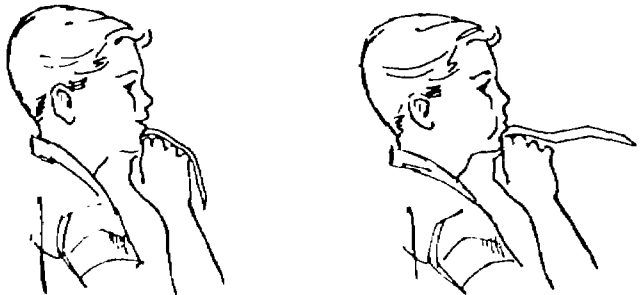

287 A

Mechanical Energy

ACTIVITY B

MATERIALS: Ping Pong ball, funnel

Place a Ping Pong ball in the wide end of a funnel and blow through the stem in an attempt to blow it out. The harder you blow the more firmly the ball will be held in place since the air moving rapidly past the ball reduces the pressure on the funnel side while atmospheric pressure holds it against the funnel.



287 B

ACTIVITY C

MATERIALS: 2 apples, string, support

Suspend two apples about two inches apart from a support with pieces of string about eighteen inches long. Blow between the apples in an effort to blow them apart. They will, instead, move together due to the reduction of air pressure on the side of the apples across which the air is moving.

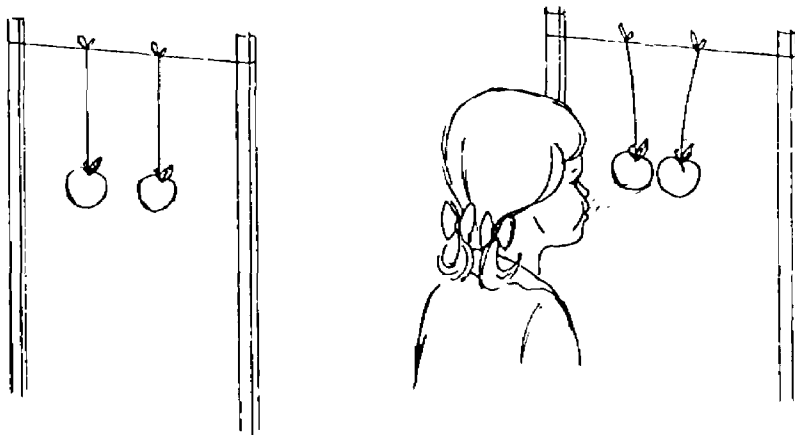

287 C

MATTER AND ENERGY

ACTIVITY D

MATERIALS: books, electric fan, paper, scissors

Cut a strip of paper about two inches wide and eight inches long. Put one end of the strip between the pages of a book and stand the book on end. Place an electric fan in a position so that it will blow over the strip of paper. The paper will lift up since the air moving rapidly over the top causes a reduction in air pressure.

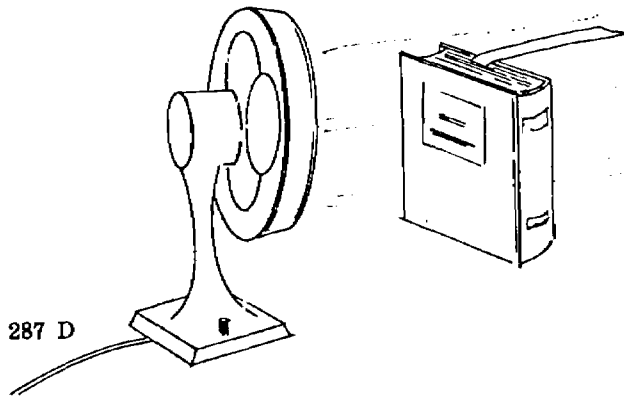

ACTIVITY E

MATERIALS: 2 empty cans

Place two empty cans on their sides about two inches apart on a smooth table. Blow directly downward between the cans. The cans will roll together due to the reduction of air pressure because of the rapidly moving air.

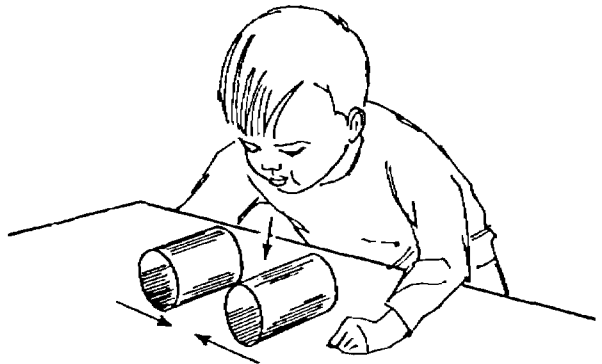

ACTIVITY F

MATERIALS: electric fan, balloon, paper clips

Blow up a balloon and weight the sealed neck of the balloon with a few paper clips. Point an electric fan upward, turn it on, and put the balloon in the stream of air. The balloon will remain on the vertical stream of air. Every time the balloon moves to the edge of the stream, the moving air on the stream side results in a lower air pressure on that side, and con-

Mechanical Energy

sequently, the balloon will be pushed back by the higher pressure outside of the stream of air

ACTIVITY G

MATERIALS: 2 books, sheet of paper, drinking straw

Lay two books about four inches apart. Place a sheet of paper on the books across the open space between them. Direct a stream of air beneath the paper by blowing through a soda straw. The paper bends downward because the pressure against its bottom surface is reduced.

ACTIVITY H

MATERIALS: spool, pin, piece of cardboard about three inches square

Push a pin through the center of a three inch square piece of cardboard. Insert the pin into the hole on one end of a spool and blow through the hole on the other end in an attempt to blow the cardboard away from the spool. The harder you blow the tighter the cardboard sticks to the spool since the air moving rapidly across the cardboard reduces the pressure on the side toward the spool and atmospheric pressure on the opposite side holds it against the spool.



287 H

288. An airplane wing is designed so that the air passing over the top of the wing moves more rapidly than the air passing under the wing, thus causing less pressure on the top than on the bottom.

ACTIVITY

MATERIALS: tagboard, glue, electric fan, pencil, scissors

In order to see how an airplane wing acts as it moves through the air, cut a piece of tagboard twelve inches long and two inches wide. Fold the strip to shape it like the cross section of an airplane wing with the bottom flat and the top slightly rounded. Once folded, glue the loose ends together.

MATTER AND ENERGY

Put a pencil through the front end of the folded wing and hold it in front of a fan first with the fan off and then with the fan on.

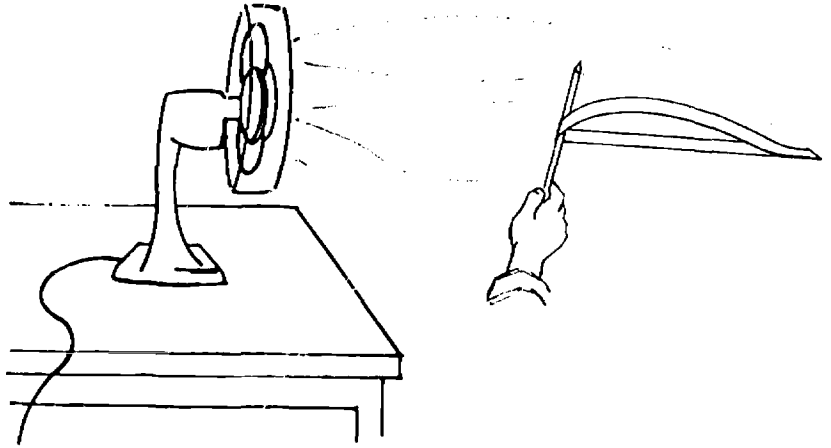

288

289. The flight of an airplane can be controlled by adjusting the surfaces of the airplane to vary the way in which air passes over them.

ACTIVITY A

MATERIALS: tagboard, scissors, pencil, ruler, knitting needle, electric fan, masking tape

Cut a top view shape of an airplane from a piece of tagboard. Attach a knitting needle along the length of the front wings with masking tape. Bend the back half of the rear wing up to represent an elevator. Hold the plane by the knitting needle in front of a fan and determine how the elevator affects it. Experiment by bending the elevator into different positions and study the effect of each position on the plane.

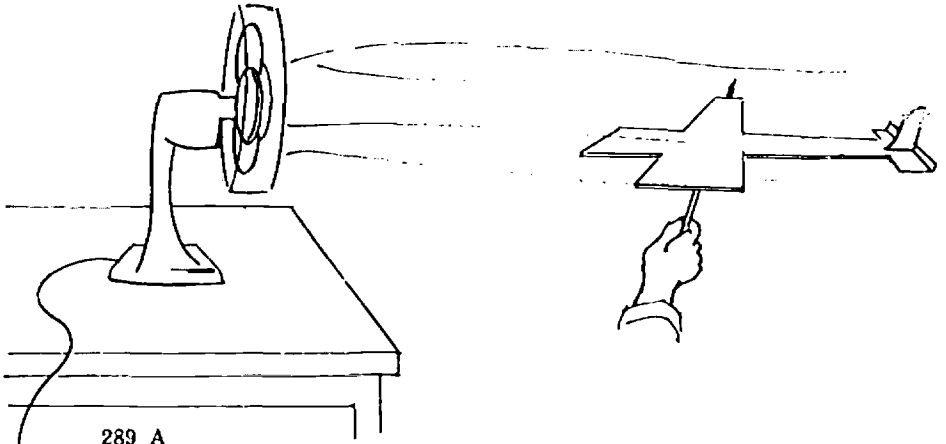

289 A

Mechanical Energy

ACTIVITY B

MATERIALS: tagboard, scissors, pencil, ruler, knitting needle, electric fan, masking tape

Cut a piece of tagboard into the shape of an airplane wing as viewed from the top. Attach a knitting needle along the length of the plane with masking tape. Cut ailerons in the wings of the plane and bend one up and the other down. Hold the plane by the knitting needle in front of the fan and determine how the air moving over the ailerons affects the plane. Experiment by bending the ailerons into different positions.

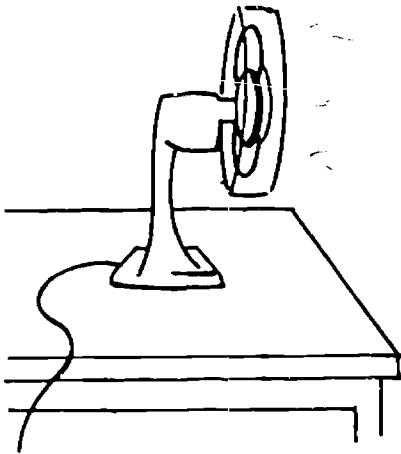

289 B

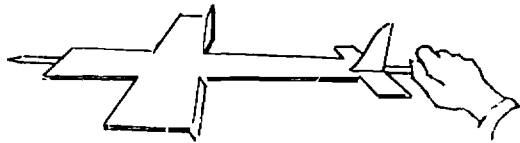

ACTIVITY C

MATERIALS: cork, tagboard, pin, fan, glue, scissors

Cut a top view shape of an airplane from a piece of tagboard. Using another piece of tagboard, cut out and glue on a rudder to extend upward on the rear of the plane. Balance the plane on a large cork and hold it in place with a single pin through the plane and the cork. Grasping the cork, hold the plane in front of a fan. Bend the rudder to different

MATTER AND ENERGY

positions left and right and see what effect each position has on the direction in which the plane points.

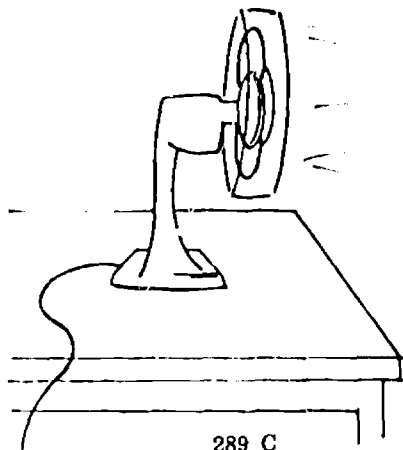

289 C

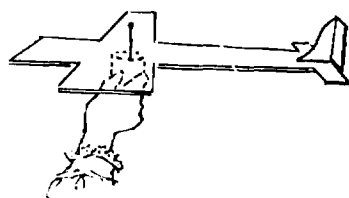

290. Water exerts an upward lifting force.

ACTIVITY

MATERIALS: large jar, water, lamp chimney, cardboard

Fill a large jar with water. Place a piece of cardboard against the bottom of a lamp chimney and lower the cardboard and lamp chimney into the jar of water. The cardboard is held against the lamp chimney by the pressure of the water.

291. Objects float if they are lighter than an equal volume of water and sink if they are heavier than an equal volume of water.

ACTIVITY

MATERIALS: pan of water, assortment of objects and materials

Place a variety of objects and materials in a pan of water. Classify them on the basis of whether or not they float. Compare your observations with the basic understanding given above.

292. An object floats if it displaces an amount of water which weighs as much as the object.

ACTIVITY

MATERIALS: tub of water, hammer, empty can open at one end

Float a can in a tub of water. Remove the can and flatten it with a hammer. Put it back into the water. It will sink because it has less volume and no longer displaces an amount of water which weighs as much as it does.

293. The denser a liquid, the more buoyancy it has for floating objects.

ACTIVITY

MATERIALS: 2 water glasses, water, 2 eggs, salt, spoon

Fill two glasses with water. Add two tablespoonfuls of salt to one glass and stir until it dissolves. Put an egg into each glass. The egg will sink

Mechanical Energy

in the fresh water, but will float in the salt water. This is because salt water is denser than fresh water.

294. Changing the weight of an object affects its buoyancy.

ACTIVITY

MATERIALS: bottle, stopper to fit bottle, small medicine vial, water

Fill a bottle with water. Invert a small medicine vial and put it into the bottle of water allowing just enough water to enter the vial so that it barely floats. Place a stopper in the top of the bottle. As you press down on the stopper, the vial will sink because water is forced into it adding to its weight. When you release the pressure, the water moves out of the vial, the weight is reduced, and the vial rises again.

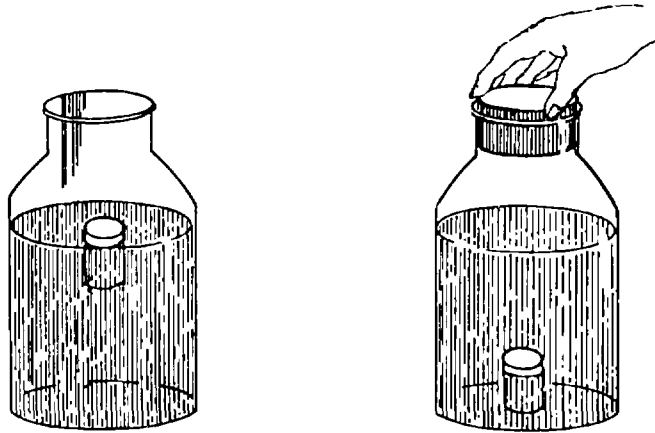

294

295. An object loses weight when submerged in a liquid because of the buoyant force of the liquid.

ACTIVITY

MATERIALS: spring balance, stone, large jar, water, string, block of wood

Tie a stone to the end of a piece of string, suspend it from a spring balance, and weigh it. While still suspended, lower the stone into a large jar of water and weigh it while it is immersed in water. Notice that the stone weighs less in water because of the buoyant force of the water. Repeat the experiment using a block of wood instead of a stone. The block of wood will not register a weight in water since the buoyant force of the water completely supports the weight of the wood.

MATTER AND ENERGY

H. Electrical Energy

296. Natural magnets can be found in nature.

ACTIVITY

MATERIALS: lodestone

Secure a natural magnet (lodestone). Demonstrate to the children that it has all of the characteristics of a magnet and behaves like any other magnet.

297. Magnets will attract some materials but not others.

ACTIVITY

MATERIALS: magnet, common objects (such as coins, tacks, pens, pencils, cloth, paper, etc.)

Touch a magnet to as many different kinds of materials as you are able to collect. Make a record of the kinds of materials which a magnet will attract and the kinds which it will not attract. Are there any general conclusions which can be drawn to distinguish between the two groups?

298. A magnet attracts with its greatest force at the ends or poles.

ACTIVITY

MATERIALS: magnet, sheet of paper, iron filings

Place a piece of paper on a bar magnet. Sprinkle iron filings on the paper and slide the paper around slowly. Notice that iron filings are attracted most strongly to the ends or poles of the magnet.

299. Unlike magnetic poles attract. Like magnetic poles repel.

ACTIVITY A

MATERIALS: 2 bar magnets, string

Suspend a bar magnet from a support with a piece of string. Using a second bar magnet, bring the north pole near the north pole of the suspended magnet and observe the results. Then bring two south poles together. Finally bring a north pole near a south pole. Do your observations support the basic understanding given above?

ACTIVITY B

MATERIALS: magnet, 2 needles, 2 corks, knife, bowl of water

Magnetize two needles by stroking them along one end of a magnet. Slice the tops off two corks and insert a needle into the center of each sliver of cork. Float the corks with needles standing vertically in a bowl of water, first with like poles above water and then with unlike poles above water. By bringing the corks and needles close to one another, the effect of a magnetic pole on another magnetic pole can be studied.

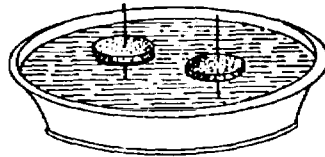

299 B

Electrical Energy

300. A magnetic field, in which magnetic force is exerted, surrounds a magnet.

ACTIVITY A

MATERIALS: bar magnet, iron filings, sheet of paper

Place a sheet of paper over a bar magnet. Gradually and evenly sprinkle iron filings on the paper. The pattern which develops indicates the magnetic field in which the force of the magnet is exerted.

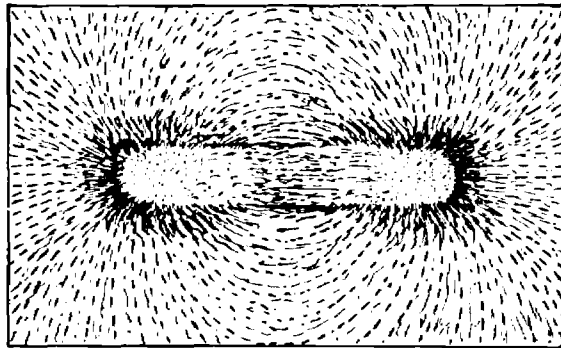

300 A

ACTIVITY B

MATERIALS: 2 bar magnets, sheet of paper, iron filings

The magnetic field related to the attraction of unlike poles and the repulsion of like poles can be illustrated by placing two bar magnets end to end with unlike poles about one inch apart. Place a sheet of paper over the magnets and sprinkle iron filings on and between the unlike poles. Notice the pattern which the filings form. Repeat the procedure, but this time have like poles an inch apart. How do the two patterns of iron filings differ from one another? These patterns represent the magnetic fields related to attraction and repulsion.

301. Magnetic forces can act through some materials.

ACTIVITY A

MATERIALS: support, horseshoe magnet, paper clip, thread, piece of paper

Hang a horseshoe magnet from a support. Tie a paper clip to one end of a piece of thread and tie the other end of the thread to the bottom of the support just below the magnet. Make the thread just long enough to reach within a quarter of an inch of the magnet. Lift the clip toward the magnet as far as it will go. The clip will "float" below the magnet. Pass a piece of paper between the magnet and the clip. The magnetic field surrounding the pole of the magnet affects the clip through both air and paper.

ACTIVITY B

MATERIALS: horseshoe magnet, iron filings, thin pieces of glass, wood, clay, paper, different metals, etc., sheet of paper

Sprinkle some iron filings on a sheet of paper. Hold a sheet of glass against the poles of a horseshoe magnet and lower them to touch the filings. Lift the glass and magnet together and observe whether the filings are attracted through the glass. Repeat this activity, replacing the glass with a variety of other materials. Record which materials the magnetic force does and does not pass through.

MATTER AND ENERGY

302. A piece of iron can be magnetized by bringing it into contact with a magnet.

ACTIVITY A

MATERIALS: magnet, nail, tacks

Touch a nail to several tacks. Notice that there is no magnetic attraction. Place the head of the nail against one end of the magnet and touch the other end to the tacks. Notice that contact with the magnet causes the nail to become magnetized.

ACTIVITY B

MATERIALS: bar magnet, nail, tacks

Touch a nail to several tacks and notice that there is no magnetic attraction. Hold the head of the nail to a magnet and touch it to the tacks. The tacks will cling, but when the magnet is separated from the nail, the nail loses most of its magnetism. Holding the nail in one hand and the magnet in the other, stroke the magnet with the nail, beginning at the center of the magnet and moving toward the end. After doing this several times, the nail will be magnetized and will attract the tacks.

303. Magnets become demagnetized when their molecular arrangements are disturbed.

ACTIVITY

MATERIALS: bar magnet, iron nails, tacks, hammer, tongs, candle

Magnetize several nails by rubbing them along one end of a bar magnet. Test their magnetism by picking up tacks. This process lines up the molecules within the nails and produces magnets. The nails can be demagnetized by disturbing this orderly arrangement of molecules. This can be accomplished by dropping the nails on the floor several times, hitting them with a hammer, or heating them in a candle flame. These procedures disturb the molecular arrangement by mechanical shock and by causing them to move around randomly due to the increase in heat energy.

Magnetized nail



303

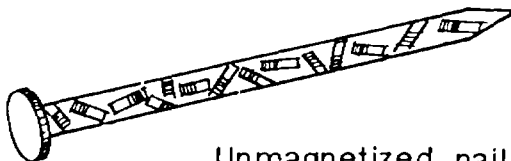

Unmagnetized nail

Electrical Energy

304. Electric current produces magnetism.

ACTIVITY A

MATERIALS: 2 dry cells, insulated copper wire, compass

Connect the center terminal of a dry cell to the outer terminal of a second dry cell. Attach one end of a two-foot piece of wire to one of the free terminals and loop it around so that the free end is near but not touching the free terminal of the other cell. Place a compass under the loop of wire and adjust the position of the materials until the compass needle is in line with the wire. Touch the loose end of the wire to the battery terminal for a second or two and then release it. Notice that the compass needle moves. This is because it is affected by the magnetism produced by electricity flowing through the wire.

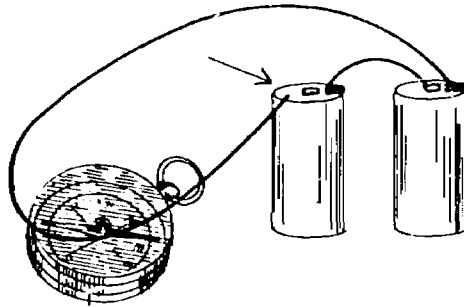

ACTIVITY B

MATERIALS: dry cell, large iron nail, paper clip, insulated wire

Wind an insulated wire around a large iron nail twenty-five or more times. Touch the nail to several paper clips and notice that it is not magnetized. Scrape the insulation from the ends of the wire and connect one end to a terminal of the dry cell. Touch the other end of the wire to the other terminal and bring the nail into contact with the paper clips. The clips will cling to the nail. Remove the wire from the dry cell terminal and the paper clips will fall away from the nail.

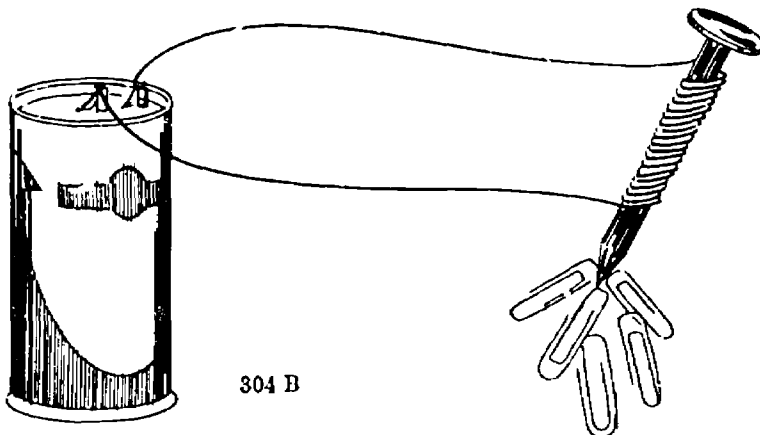

MATTER AND ENERGY

ACTIVITY C

MATERIALS: 2 dry cells, 2 large nails, paper clips, insulated wire

An electrical current passing through a wire wrapped around an iron nail will cause the nail to be magnetized. The nail wrapped with a wire which is carrying electricity is called an electromagnet. The strength of an electromagnet depends upon the number of turns of wire around the nail and the amount of current passing through the wire. Make two electromagnets by wrapping one nail with 15 turns of wire and another with 30 turns of wire. Activate the electromagnets by connecting them to separate dry cells and see how many paper clips each will pick up. The electromagnet with 30 turns of wire is stronger than the electromagnet with 15 turns of wire.

Test the strength of an electromagnet with 30 turns of wire by picking up paper clips, first when connected to one dry cell and then when connected to two dry cells connected in series. (A series connection of the cells means that the center terminal of one is connected to the outer terminal of the other.) The strength of the electromagnet increases as the source of electricity becomes stronger.

305. The earth acts like a magnet.

ACTIVITY

MATERIALS: bowl of water, cork, sewing needle

Magnetize a sewing needle by stroking it along one end of a magnet. Cut a slice of cork, float it in a bowl of water, and place the magnetized needle on the cork. The freely floating needle will become a compass, lining up in a north and south direction. The earth's magnetic field causes it to assume this alignment.

306. We use magnets in many ways.

ACTIVITY

MATERIALS: devices which use magnetism

Have the children collect and display all devices which they can find which use magnetism. This can include both permanent magnets and electromagnets. Examples which cannot be brought to school can be drawn and added to the display.

307. Static electricity can be produced by friction.

ACTIVITY A

MATERIALS: balloon

Rub a balloon against woolen clothing and place it against the wall. The balloon will cling to the wall because of the static electrical charge which it receives.

ACTIVITY B

MATERIALS: wool cloth, hard rubber comb, small pieces of paper

Rub a hard rubber comb with a piece of wool or move it several times through your hair. Touch the rod to several small pieces of paper. The negative static charge on the comb will cause the pieces of paper to cling to it.

Electrical Energy

ACTIVITY C

MATERIALS: hard rubber comb, piece of cork, wool cloth, thread

Use thread to suspend a small piece of cork from a support. Rub a hard rubber comb with a piece of wool cloth and bring the comb near the piece of cork. Notice how the cork swings out toward the comb. Allow the cork to touch the comb, move the comb away, and then bring it toward the cork again. The cork now moves away from the comb. Rubbing the comb with the wool cloth produces a negative electrical charge on the comb which attracts the cork. However, when they touch, the cork picks up the negative charge and since negative charges repel one another, the cork will now move away from the comb.

ACTIVITY D

MATERIALS: hard rubber comb, wool cloth, sink

Rub a hard rubber comb with a wool cloth. Turn on a faucet to allow a thin stream of water flow and hold the rubber comb near the stream of water. The flow of water will be attracted toward and will bend out to the comb because of the static electrical charge which it receives.

ACTIVITY E

MATERIALS: piece of glass about 10 inches square, 2 books, silk cloth, scissors, tissue paper

Cut tiny paper dolls out of tissue paper and put them between two books which have been placed about five inches apart. Lay a piece of glass on the books so it is placed over the paper dolls. Rub the glass with silk. The paper dolls will move up and down. Rubbing glass with silk produces positively charged static electricity on the glass which attracts the paper dolls.

308. A negative static electrical charge is due to an excess accumulation of electrons on an object.

ACTIVITY

MATERIALS: hard rubber rod, wool or fur, pith balls suspended from support

Rub a hard rubber rod with wool or fur. Touch the rod to suspended pith balls and watch how they are at first attracted and then repelled. This is evidence of the existence of a static electrical charge. This is a negative charge produced by rubbing negatively charged electrons from the wool or fur to the hard rubber rod.

309. A positive static electrical charge is due to an object containing more protons than electrons.

ACTIVITY

MATERIALS: glass rod, silk, pith balls suspended from support

Rub a glass rod with silk. Touch the rod to suspended pith balls and watch how they are at first attracted and then repelled. This is evidence of the existence of a static electrical charge. This is a positive charge produced by rubbing electrons off the glass with the silk and leaving an excess of positively charged protons on the rod.

310. Objects which are charged with static electricity exert forces on one another.

ACTIVITY

MATERIALS: plastic toothbrush container, puffed rice, wool or fur

Put several grains of puffed rice in a plastic toothbrush container. Rub the container with fur or wool. This will produce a static electrical charge. Notice the effect that this charge has on the grains of puffed rice.

MATTER AND ENERGY

311. Unlike static electrical charges attract. Like static electrical charges repel.

ACTIVITY

MATERIALS: hard rubber rod, glass rod, wool or fur, silk, pith balls suspended from support

Rub a hard rubber rod with wool or fur. This will rub electrons onto the rod and give it a negative static charge. Touch the rod to suspended pith balls. At first they are attracted, but when they pick up electrons and become negatively charged, they are repelled from the rod. This indicates that like static charges repel.

Leaving the pith balls negatively charged, rub a glass rod with silk. This rubs electrons from the rod leaving it positively charged with an excess of protons. Touch it to the pith balls and notice that it attracts the balls indicating that unlike charges attract. Continue to experiment with the apparatus and explain all observations in terms of the laws of electrostatics.

312. Current electricity is the flow of electrons along a conductor.

ACTIVITY

MATERIALS: marbles, $\frac{3}{4}$ " diameter glass tube.

Illustrate the flow of electric current by filling a glass tube with marbles. As one marble is pushed in one end, a marble comes out the other end.

313. Electricity can be produced in many ways.

ACTIVITY

MATERIALS: references

Have the children search for pictures and information on ways in which electricity can be produced. Make a list and discuss the advantages of each.

314. Current electricity can be produced in a conductor by breaking magnetic lines of force with a conductor.

ACTIVITY

MATERIALS: galvanometer, coil of wire, magnet

Connect the ends of a coil of wire to a galvanometer. Pass a magnet back and forth through the coil and notice from the deflection of the needle of the galvanometer that a current is flowing.

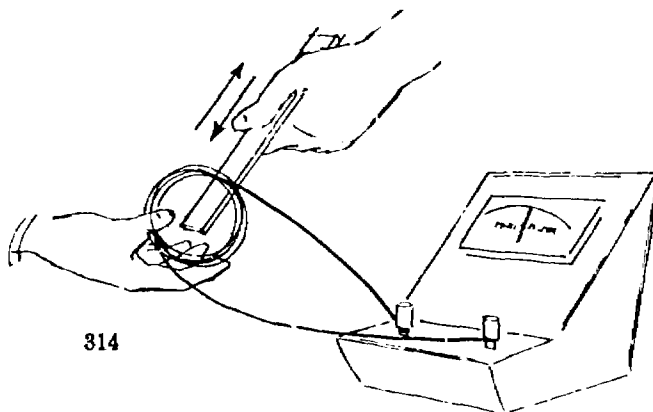

Electrical Energy

315. Current electricity can be produced by a chemical reaction.

ACTIVITY A

MATERIALS: penny, dime, lemon, galvanometer, wire
Push a penny and a dime through the skin of a lemon about an inch apart. Connect each coin to a separate terminal of a galvanometer with wire. Notice from the deflection of the needle that a current is flowing. Repeat the experiment using other fruits and vegetables.

ACTIVITY B

MATERIALS: penny, dime, paper towel, water, galvanometer, wire

Moisten a piece of paper towel and put it between a penny and a dime. Touch a wire from one terminal of a galvanometer to the penny and a wire from the other terminal to the dime. Notice from the deflection of the needle that a current is flowing.

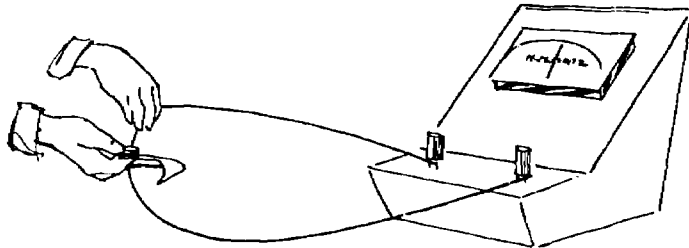

315 B

316. Current electricity can be produced by a solar cell.

ACTIVITY

Contact your local telephone company representative for information about, and possibly a demonstration of, solar cells and how they are being used in the communications industry.

317. Current electricity can be produced by heating two different metals at the point where they join together.

ACTIVITY

MATERIALS: copper wire, nickel wire, alcohol burner, galvanometer

Join an uninsulated piece of copper wire to an uninsulated nickel wire by twisting them together firmly. Connect the free ends to a galvanometer. Heat the point where the copper and nickel join and watch the galvanometer for evidence of current flow.

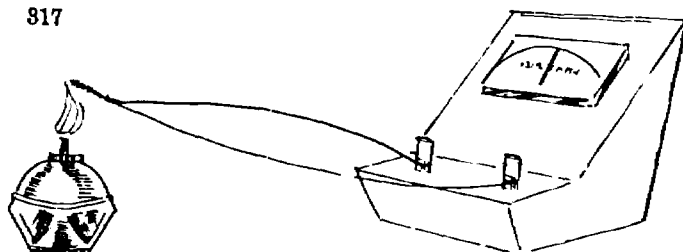

317

MATTER AND ENERGY

318. Current electricity can be produced very efficiently by a chemical reaction in a fuel cell.

ACTIVITY

MATERIALS: references

Consult references to learn about how a fuel cell operates, ways in which fuel cells are used, and some of the advantages of their use.

319. Electricity flows only when it has a complete path or circuit.

ACTIVITY

MATERIALS: dry cell, electric bell, two 10-inch pieces of insulated wire

Scrape the insulation from the ends of the wires. Experiment with the dry cell, two wires, and bell until you can get the bell to ring. Notice that to get the bell to ring, a closed path must be provided for the flow of electricity. A wire must run from one terminal of the cell to one connecting post on the bell and the other wire must run from the other connecting post on the bell to the remaining open terminal on the dry cell.

319

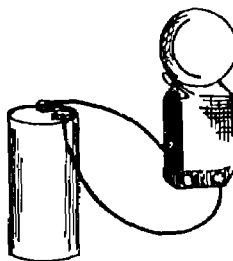

320. Current electricity flows through a complete circuit.

ACTIVITY

MATERIALS: flashlight cell, flashlight bulb, copper wire

Remove the insulation from each end of a six-inch piece of wire. Wrap one end around the base of a flashlight bulb. While holding the other end against the bottom of a flashlight cell, press the tip of the base of the bulb against the terminal of the cell. What happens? What components and procedures are needed to light a bulb?

320

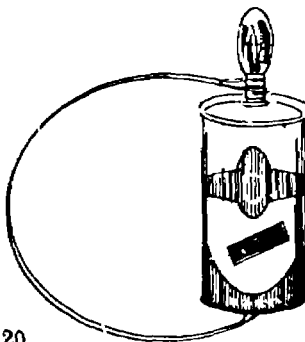

Electrical Energy

321. Electric cells can be connected in a series circuit.

ACTIVITY

MATERIALS: 3 dry cells, electric bell, four 10-inch pieces of insulated wire

Scrape the insulation from the ends of the wires. Connect the center post of one dry cell with the outer post of a second dry cell. Connect the center post of the second dry cell with the outer post of the third dry cell. Connect one binding post on the bell to the free terminal on the first cell and the other bell binding post to the free terminal on the third cell. The cells are connected in a series circuit and the bell rings.

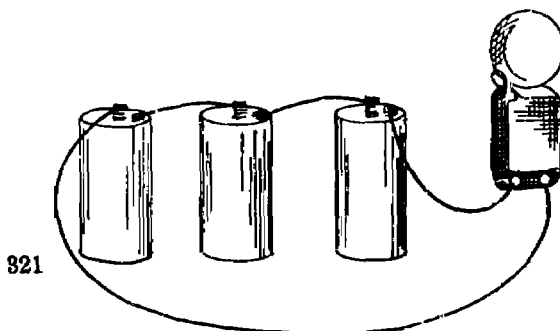

322. Electric cells can be connected in a parallel circuit.

ACTIVITY

MATERIALS: 3 dry cells, electric bell, six 10-inch pieces of insulated wire

Scrape the insulation from the ends of the wires. Connect the center post of one dry cell to the center post of the second dry cell. Connect the center post of the second dry cell to the center post of the third dry cell. Connect the center post of the third dry cell to one binding post of a bell. Connect the outer posts of the dry cells and the bell together in the same manner as you proceeded with the center posts. The cells are connected in a parallel circuit and the bell rings.

323. Current electricity can flow as either direct current or as alternating current.

ACTIVITY

MATERIALS: $\frac{3}{4}$ " diameter glass tube, marbles, cardboard cut the size and shape of a light bulb, tape

Lay the glass tube horizontally on a table. Imagine it to represent a wire. Fill it with marbles to represent electrons. Tape a cardboard "light bulb" on the center of the tube. To carry out the analogy, electrons must pass through the light bulb if it is going to light. There are two methods for them to pass through. One method is for them to pass in one direction only. The other is for them to go back and forth.

Introduce marbles at one end of the tube forcing the other marbles along the tube. Notice that the marbles are passing through the bulb and therefore it is getting current. This represents a one-way current, called direct current.

Introduce a marble at one end and then a marble at the other end and

MATTER AND ENERGY

continue to alternate ends. Notice that the marbles are passing through the bulb by moving back and forth. This represents a type of current called alternating current.

324. Electricity flows through some materials better than others.

ACTIVITY

MATERIALS: 1½ volt dry cell, wire, unpainted thumbtacks, block of wood, 1½ volt bulb and socket, rubber band, paper, nail, pins, glass, variety of other materials

Materials can be tested to determine whether they conduct electricity by constructing a simple device. Push two thumbtacks into a block of wood separating them by about an inch. Construct a circuit by running a wire from a dry cell to a thumbtack, from the other thumbtack to a light socket, and from the light socket to the other terminal of the dry cell. One at a time, place a rubber band, paper, nail, and other materials between the two tacks and see if they are conductors (carry electricity) or nonconductors (do not carry electricity). Discuss the importance of both conductors and nonconductors.

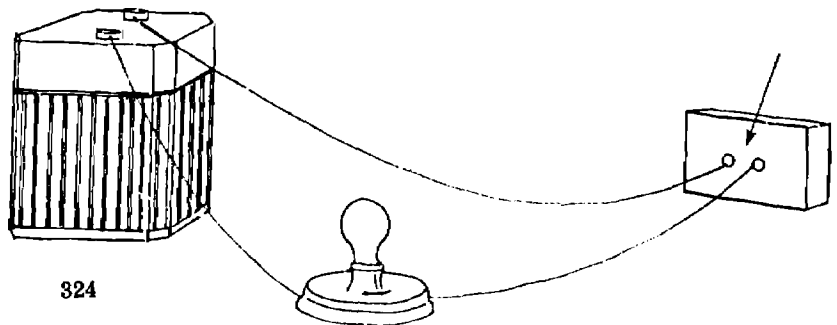

325. A switch can complete or break an electric circuit.

ACTIVITY

MATERIALS: dry cell, electric bell, three 10-inch pieces of insulated wire, push button switch

Scrape the insulation from the ends of the three pieces of wire. Connect one wire to a terminal of the dry cell and the connecting post of the bell. Attach a second wire to the remaining connecting post of the bell. Attach a third wire to the open terminal of the dry cell. Experiment with the two free ends of wire by connecting and separating them. By so doing, you are operating a switch which completes and breaks an electric circuit resulting in turning the bell on and off. Connect the push button switch to the two free ends and see how it provides a more convenient way to open and close the circuit.

Electrical Energy

326. A "short circuit" is produced when uninsulated wires leading to and from a resistance come into contact with one another.

ACTIVITY

MATERIALS: 1½ volt dry cell, wire, 1½ volt bulb and socket

Remove the insulation from the ends and about an inch from the center of two ten-inch pieces of wire. Connect each wire from one terminal of a dry cell to one terminal on a bulb socket. The bulb should light. Now, very quickly touch the bare center of one wire to the bare center of the other and separate them immediately. Notice that when the wires are in contact, they become very hot and the light goes out. Can you explain this? Why is this kind of contact called a "short circuit"? Why is a short circuit dangerous?

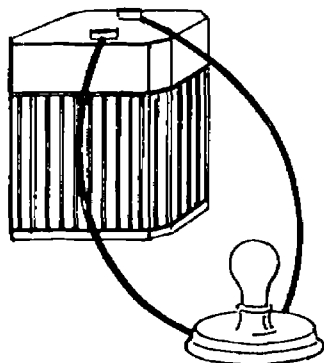

326

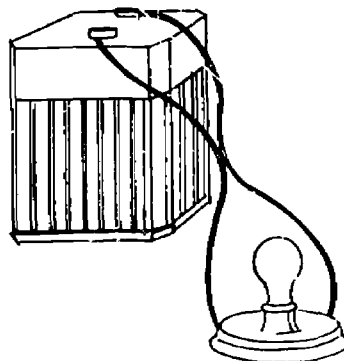

327. Electric current can cause chemical reactions to take place.

ACTIVITY A

MATERIALS: dry cell, glass of water, 2 strips of copper wire, potassium iodide, test tube, red litmus paper

Dissolve some potassium iodide in water. Using wire, attach two strips of copper to separate terminals on a dry cell. Immerse the copper strips in the potassium iodide solution. The following reactions will take place:

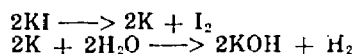

Have the students devise methods to detect evidence of these reactions. For example, the iodine is recognized by its color. The hydrogen can be collected in a test tube and tested with a flame (it burns). The presence of KOH, a base, can be detected with red litmus paper which will turn blue.

MATTER AND ENERGY

ACTIVITY B

MATERIALS: glass of water, copper sulfate, wire, dry cell, strip of copper, large iron nail, sandpaper or steel wool

Dissolve about a teaspoonful of copper sulfate in a glass of water. Clean a strip of copper and an iron nail with sandpaper or steel wool. With wire, attach the copper to the positive terminal of a dry cell and the nail to the negative terminal. Put the copper and nail into the copper sulfate solution. Check the nail periodically and note the coat of copper which develops on it. This type of process is known as electroplating.

328. Electricity helps us in many ways.

ACTIVITY

MATERIALS: electrical devices, magazines, scissors, paper, crayons

Have the children collect and display appliances and devices which use electricity. Include in the display pictures and drawings of electrical devices which cannot be brought into the classroom. Discuss how you would accomplish the task which each of these devices performs if you did not have electricity.

329. Electrical energy can be converted into many other useful forms of energy.

ACTIVITY

Have the children explore their homes and community and be prepared to contribute to developing a list of devices which convert electricity into other useful forms of energy. Prepare such lists on large sheets of paper under the classifications of chemical, mechanical, sound, light, and heat energy.

330. Electric motors convert electrical energy into mechanical energy.

ACTIVITY A

MATERIALS: 2 bar magnets, support, string

Suspend a bar magnet horizontally by hanging it with a string from a support. Using the other magnet, bring its poles near, but not touching, the poles of the suspended magnet in such a way as to see it in motion and keep it moving in a revolving motion. In so doing, you are demonstrating essentially how an electric motor operates. The electric motor, however, uses electromagnets the poles of which are varied automatically.

ACTIVITY B

MATERIALS: electric motor, references

Secure an electric motor (or an appliance which contains an electric motor) in which the parts of the motor are visible. Examine the parts, consult reference books for information about them, and discuss what each part does.

ACTIVITY C

MATERIALS: reference books

Locate a book which gives instructions for making an electric motor and have at least one boy construct a motor and demonstrate it to the class. Such books are numerous and at least one should be available in the school library.

Electrical Energy

331. Modern communication devices operate according to the principles of electricity and magnetism.

ACTIVITY

Arrange for a representative of your local telephone company to visit the school and demonstrate the operation and use of a telephone.

332. Forms of modern communication are dependent upon electronic devices.

ACTIVITY

Arrange to visit a nearby radio or television station. While there, have the engineer show the children some of the complex electronic equipment necessary to transmit radio signals. Have the engineer explain, in simple language, the essential role which is played by each bank of electronic equipment.

333. Homes and buildings which use electricity contain safety devices to prevent possible danger.

ACTIVITY

MATERIALS: fuse, burned fuse

When more electric current passes through wires than they are designed to handle, they become hot and can cause fire. In order to prevent this, fuses or circuit breakers are used. Show the children a good fuse and a burned-out fuse. Fuses contain a metal wire which, when it becomes dangerously warm, melts and stops the flow of electricity. Have the school janitor show the children the fuses or circuit breaker switches in the school.

334. Fuses are used to protect against the hazards of a "short circuit."

ACTIVITY

MATERIALS: $1\frac{1}{2}$ volt dry cell, wire, $1\frac{1}{2}$ volt bulb and socket, unpainted thumbtacks, block of wood, metallic Christmas tree tinsel

Tack both ends of a short piece of metallic tinsel to a block of wood. Prepare a circuit from a terminal of a dry cell to the tinsel, from the tinsel to a bulb socket, and from the bulb socket to the other terminal of the cell. Short circuit the bulb by touching the ends of a short piece of wire to the terminals of the bulb socket. What happens to the tinsel? Why is such a device so important to the safety of our homes?

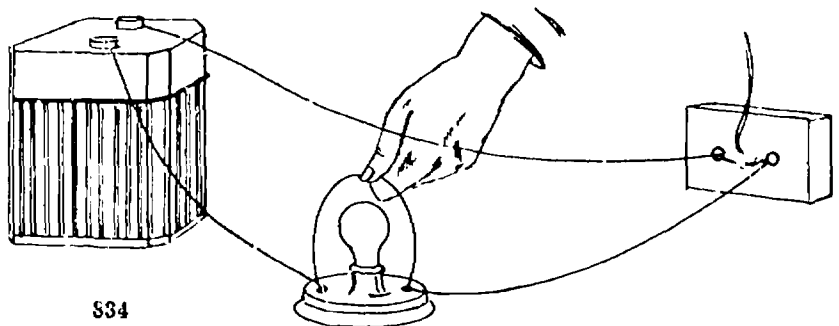

IV. EARTH AND SPACE

A. Earth

335. Fossils provide evidence of plants and animals that once lived on the earth.

ACTIVITY

MATERIALS: fossils, references

Inquire of high school science teachers and others who might know whether fossils can be located in your area. If so, search for some and attempt to identify them.

336. Fossils can be formed by living things leaving an imprint on other materials.

ACTIVITY

MATERIALS: leaf, Vaseline, cardboard, pane of glass, clay, plaster of Paris

Cover a leaf with Vaseline and place it on a pane of glass. Surround the leaf by a cardboard frame held in place with clay on the outside. Pour plaster of Paris on the leaf. When it has hardened, a leaf print will be formed. Certain type of fossils are formed in nature in a similar manner.

337. The land surface of the earth exists in a variety of forms.

ACTIVITY

MATERIALS: sand, soil, clay, plaster of Paris, paper-mache

Using a variety of materials, prepare a relief model on a table which shows as many features of the earth's surface as possible.

338. Water covers the greatest part of the earth.

ACTIVITY

MATERIALS: globe

Using a globe, estimate the percentage of the earth's surface that is covered by water. Have each child in the class make his own estimate and average them. Have the children search for a published estimate for comparison. The amount should be about 71%.

339. Many types of bodies of water exist on the surface of the earth.

ACTIVITY

MATERIALS: globe, maps

Explore your community and its surroundings and list the bodies of water and sources of water which exist. Examine a variety of maps and a globe and locate the blue areas. What types of bodies of water and waterways do these markings represent? Add these to your list.

340. The earth's structure includes a variety of different layers.

ACTIVITY

MATERIALS: books on the earth's composition, clay, tempera paint

Locate a book in the library which shows the structure of the earth including the crust, mantle, and core. Using clay and tempera paints, make a cross section model of the earth.

Earth

341. There are many kinds of rocks and minerals in the earth.

ACTIVITY A

MATERIALS: rocks

Have the children collect as many different pieces of rocks as they can find and bring them to class. Through careful examination have them divide and classify the rocks into as many distinct groups as possible.

ACTIVITY B

MATERIALS: rocks, cloth, hammer, magnifying glass

Examine the makeup of rocks by wrapping them in cloth and breaking them with a hammer. A magnifying glass can be used to help in the examination. Note the differences between rocks.

ACTIVITY C

MATERIALS: rocks, minerals, books on rock and mineral identification

Gather samples of rocks and minerals which can be found in your community. Consult the librarian for books which will assist you in identifying them.

342. Some types of rocks can be identified by chemical tests.

ACTIVITY

MATERIALS: limestone, 3 different rocks, 4 dishes, vinegar

Put a piece of limestone and three rocks which do not contain limestone on four separate dishes. Pour vinegar on each rock. The acid in the vinegar will react with the limestone causing bubbling which provides a convenient test for limestone.

343. Some types of rocks can be identified by their hardness.

ACTIVITY

MATERIALS: rocks, penny, knife, glass

The relative hardness of different rocks can be tested. Collect samples of rocks and group them according to hardness: those which can be scratched with your fingernail (softest); those which can be scratched with a penny (next softest); those which can be scratched with a knife blade (harder); and those which can scratch glass (hardest).

344. Igneous rocks are formed by the cooling of molten material.

ACTIVITY

MATERIALS: samples of igneous rocks, magnifying glass

Have the children examine a variety of igneous rocks by feeling them and observing them through a magnifying glass. Discuss them in view of your observations and a knowledge of how they were formed. Igneous rocks may be purchased from science supply companies and some museums.

345. Sedimentary rocks are formed by the hardening of materials which build up over a period of time.

ACTIVITY

MATERIALS: cement, sand, gravel, water, milk carton

To illustrate how some sedimentary rocks are formed, mix cement, sand, gravel, and water in a milk carton. When the mixture hardens, peel away the carton and examine carefully.

EARTH AND SPACE

346. Metamorphic rocks result from changes in other rocks due to such factors as heat and pressure.

ACTIVITY

MATERIALS: marble, limestone, slate, shale

Marble is a metamorphic rock which was formed from limestone. Slate was formed from shale. Compare, before and after, samples of these two examples of change and discuss the apparent changes which have taken place in each.

347. A mineral has specific properties and chemical composition that can be used to identify it.

ACTIVITY

MATERIALS: rocks, minerals

Use several rocks and minerals to illustrate the differences between a rock and a mineral. A mineral is a specific substance with a particular chemical composition. A rock can be a combination of several minerals. Rocks consisting of a variety of minerals can be found and examined.

348. Temperature changes can cause rocks to break down into soil.

ACTIVITY A

MATERIALS: sandstone, tongs, alcohol burner, bowl, cold water

Heat a piece of sandstone over a hot flame for several minutes and drop it into a bowl of cold water. The sandstone will crack. Relate this to how temperature changes can cause rocks to break and form soil.

ACTIVITY B

MATERIALS: glass marbles, frying pan, hot plate, pan, cold water

Heat several glass marbles in a frying pan on a hot plate for a few minutes. While still hot, pour them into a pan of cold water. After they have had time to cool, examine them carefully for cracks. Relate what you see to how temperature changes affect rocks.

ACTIVITY C

MATERIALS: fruit jar, water, cloth, string

Rocks being broken down into soil by freezing water can be illustrated with a tightly sealed jar of water. Tie several thicknesses of cloth around the jar and either put it into the freezer compartment of a refrigerator or out-of-doors on a below-freezing night. After the water has frozen, unwrap the jar and examine it.

349. Soils can be classified into a number of types.

ACTIVITY

MATERIALS: book on soils, jars, soil samples

Locate a book which can assist you in identifying humus, loam, sand, gravel, and clay soils. Gather samples from as many sources as you can and label them according to the classification which they most nearly fit.

350. Tests can be used to identify the components of soil.

ACTIVITY A

MATERIALS: jar, soil, water

Pour a soil sample into a jar, filling it about half full. Add water to within about an inch of the top. Shake it vigorously and allow it to settle. Since the coarsest part will settle to the bottom of the jar first and the finest part will settle more slowly, a cross section of the makeup of the soil can be viewed through the side.

ACTIVITY B

MATERIALS: litmus paper, soil samples, rain water or distilled water, several small jars

In order to best grow certain plants, it is first necessary to determine whether the soil is acid or basic. This can be accomplished with a simple chemical test since blue litmus paper turns red in an acid solution and red litmus paper turns blue in a basic solution. Collect several soil samples in small jars. Add some rain water or distilled water to the soil and test with litmus paper.

351. Soils differ in materials needed for plant growth.

ACTIVITY

MATERIALS: jars, packet of seeds, variety of soils

Obtain samples of soil from such places as a flower garden, a wooded area, a place where a foundation is being dug, a sandy shore, a clay bank, and a dirt road. Place the samples in separate jars and plant seeds in each. Care for all jars uniformly. Notice in which jars the seeds sprout first and in which jars the plants grow best.

352. Soil erosion occurs when the natural cover of trees and grass is removed.

ACTIVITY

MATERIALS: can with nail holes in bottom, 2 large cake pans, 2 boards (8" x 12"), water, pint jar, dirt, sod

On one board, place a piece of sod about ten inches square. On another board build a layer of moist dirt the same size and thickness as the sod. Have two people place the two boards over separate cake pans with one end of each board in the pan and the other elevated at an angle of about 30 degrees. Hold a can with holes in the bottom over one of the soil samples and pour a pint of water into the can allowing it to "rain" on the sample. Repeat the same procedure with the other soil sample. After the water has run off both samples, compare the soil runoff from each. Accurate comparisons can be made by filtering the runoff in each pan. What conclusions can be drawn about preventing erosion on a hillside?

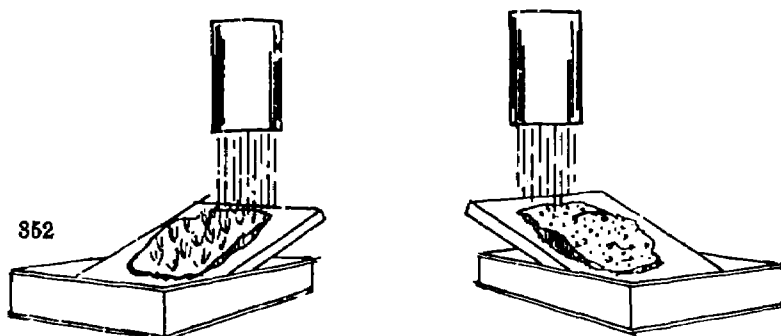

EARTH AND SPACE

353. Soil erosion can be reduced by careful soil preparation and management.

ACTIVITY

MATERIALS: can with nail holes in bottom, 2 large cake pans, 2 boards 12" square, water, pint jar, dirt

On two boards, build a layer of moist soil about an inch thick and ten inches square. Have two people place the two boards over separate cake pans with one end of each board in the pan and the other elevated at an angle of about 30 degrees. With a pencil, scratch grooves about one-half inch deep in both soil samples making them horizontal on one sample and vertical on the other.

Hold a can with holes in the bottom over one of the soil samples and pour a pint of water into the can allowing it to "rain" on the sample. Repeat the same procedure with the other soil sample. After the water has run off both samples, compare the soil runoff from each. Accurate comparisons can be made by filtering the runoff in each pan. What conclusions can be drawn about preventing erosion on a hillside?

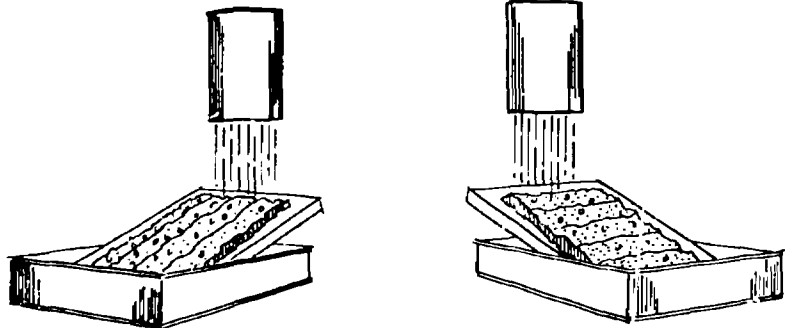

353

354. The earth's surface is always changing.

ACTIVITY

MATERIALS: string, wooden stakes, rake, hoe, camera and film

Mark off a small plot of ground a few feet square on the school campus. Clear it of any plants and rake it smooth and flat. Examine it periodically—particularly after strong winds and rain. Keep a record of changes which take place. A periodic sequence of photographs would provide an excellent record of change.

355. Chemical weathering can cause changes in the earth's surface.

ACTIVITY

MATERIALS: pan, hot plate, vinegar, chip of marble

Decaying plants and animals often produce chemicals which react with and change rocks. To illustrate this, put a small chip of marble into a pan of vinegar and boil it for five or ten minutes. Note any changes which occur.

356. Freezing of water can cause changes in the earth's surface.

ACTIVITY

MATERIALS: small jar, cloth, string, refrigerator

When water freezes in a crack in a rock or in the space between two rocks, the resulting expansion can produce breakage or other changes. To illustrate this, fill a small jar with water and close its lid tightly. Wrap the jar with several layers of cloth, tie them on with string, and put the jar into the refrigerator freezing compartment over night. Unwrap the jar the following day and examine the breakage carefully.

357. Rainfall can cause changes in the earth's surface.

ACTIVITY

MATERIALS: wooden stake, ruler

When raindrops strike the ground, soil is dislodged and splashes with the rain. The height to which it splashes can be measured by attaching a ruler to a wooden stake which has been firmly driven into the ground. Following a rainfall, check to see how high the dirt splashed. Wipe the ruler clean and record the splash height after other rainfalls. Note the variations and discuss reasons for them.

358. Landslides can be caused by weathering.

ACTIVITY

MATERIALS: shovel, soil, hose

Prepare a pile of dirt about two or three feet high. Squirt water at the base of the pile and observe the landslides that result.

359. Moving water carries loose soil from one place on the earth to another.

ACTIVITY A

MATERIALS: 2 rectangular aluminum baking pans, soil, water, nail, hammer

Put some moist soil into an aluminum baking pan. Prop one end up a few inches and punch a hole in the other end with a nail to allow water to escape. Place the lower end into another baking pan. Pour about a half cup of water into the soil each day. Notice over a period of several days how the soil is carried away by the water.

ACTIVITY B

MATERIALS: quart jar, water, soil

Soil can remain suspended in water for a long period of time and therefore is easily transported by even slow-moving rivers and streams. To illustrate this suspension, put a few inches of soil into a quart jar and add two cups of water. Shake vigorously. Examine the water periodically during the day and days that follow and note the rate at which the soil settles. Does it ever completely settle?

360. Wind carries loose soil from one place on the earth to another.

ACTIVITY

MATERIALS: sandbox, electric fan, stones, pieces of wood

Smooth and dry the sand in a sandbox. Place an electric fan in a position to blow on the sand. Observe the movement. Place stones and small pieces of wood on the sand and see how these affect the pattern in which the sand is distributed.

EARTH AND SPACE

361. Earthquakes cause changes in the earth's surface.

ACTIVITY

Earthquakes are caused by stretching, shifting, settling, and cracking in the earth's surface. To illustrate this, have the children locate cracks in sidewalks, roads, and foundations of homes. Can they determine the causes of these cracks? Do some of the same causes result in cracks and earthquakes over larger portions of the earth's surface?

362. The action of volcanoes causes changes in the earth's surface.

ACTIVITY

MATERIALS: ammonium bichromate, magnesium powder,
magnesium ribbon, clay, matches

To illustrate the action of volcanoes, build a cone-shaped mountain of clay about five inches high. With your finger, push a hole in the top of the mountain about an inch deep and a half inch in diameter. Fill the hole with ammonium bichromate. Mix a little magnesium powder with the ammonium bichromate and stir. Using magnesium ribbon for a wick, light the ammonium bichromate and observe the volcanic action.

Precautions should be taken to protect eyes from bright light and heat.

363. Man sometimes alters the surface of the earth to suit his needs.

ACTIVITY

Have the children search the community and surrounding area for examples of how man has altered the earth's surface. Excavations for buildings, road construction, shopping centers, and other examples are numerous. Discuss the effects which these alterations have had on the surrounding land.

364. Water is present in the soil.

ACTIVITY

MATERIALS: 3 funnels, 3 glasses, 3 pieces of cloth, clay,
sand, loam, water, string, cup

Tie a piece of cloth over the small end of each of the three funnels. Fill the three funnels to within an inch of the top—one with clay, one with sand, and one with loam. Put the funnels over glasses and pour one cup of water into each. From what you observe, rank the three materials in order of their ability to absorb moisture.

365. Cultivation of the soil prepares it to absorb water more readily.

ACTIVITY

MATERIALS: baking pans, soil, sprinkling can, water

Fill two baking pans with soil. Pack the soil tightly in one and loosely in the other. Sprinkle equal amounts of water on both soil samples and compare the rate at which each absorbs the water.

366. Irrigation can increase farm production by providing farm plants with a regular supply of water.

ACTIVITY

Visit a farm, floral shop, or plant nursery which uses irrigation methods to provide plants with a regular supply of water. Discuss the advantages.

Earth

- 367. When the earth's surface is altered by man, careful provisions must be made for water drainage.**

ACTIVITY

Examine areas which have been developed for streets, superhighways, shopping centers, etc. What steps have been taken in each case to provide for water drainage? If not properly provided for, erosion and flooding can occur. Can you locate areas where drainage is not good?

- 368. Man obtains many useful materials from the earth.**

ACTIVITY A

Fuels such as coal, oil, and gas which heat our houses are obtained from the earth. Have the children find out at home what fuel is used to heat their homes. Make a count of the children in the class who use each type of fuel in their homes.

ACTIVITY B

MATERIALS: magazines, scissors, paper, glue,
crayons, bulletin board

Coal, gas, and oil are natural resources obtained from the earth. Have the children discuss ways in which these are used, draw and cut from magazines pictures to illustrate these uses, and mount these pictures on a bulletin board. Examples of other natural resources may be used if desired.

- 369. Our modern world is dependent upon many minerals which are obtained from the earth.**

ACTIVITY

MATERIALS: mineral products

Collect and display an assortment of objects which are made of minerals from the earth. Illustrate not only the fact that there are a lot of different minerals but also that each mineral is used in many ways.

- 370. Since mineral resources are limited, care must be taken to conserve them.**

ACTIVITY

MATERIALS: globe, iron objects

Prepare a display of objects and pictures of objects which are made of iron. Refer to a globe and point out that all of the iron which is being used is mined from the earth. Suggest the possibility that someday all of this iron will be mined. Discuss what can be done to prevent this problem and what will have to be done if the supply is ever exhausted.

EARTH AND SPACE

B. Earth's Atmosphere

371. Air has weight.

ACTIVITY A

MATERIALS: quart milk bottle, hard-boiled egg, paper, match

Light a piece of paper with a match, put it into a quart milk bottle, and place a shelled, hard-boiled egg, pointed end down, in the mouth of the bottle. Observe carefully. The expanding hot air will cause air to leave the bottle, and then, as the air cools, the greater air pressure on the outside of the bottle will force the egg into the bottle.

ACTIVITY B

MATERIALS: newspaper, thin slat of wood, hammer

Place a slat of wood on the edge of a table allowing about six inches to extend over the side. Spread several sheets of newspaper over the part of the wood which is on the table. Strike the protruding end sharply with a hammer. The weight of the air on the paper will cause the slat to break while the portion on the table and the newspaper barely move.

ACTIVITY C

MATERIALS: jar, water, soda straw

Fill a jar with water. Put a drinking straw into the jar, place your finger over the opening at the top, and lift the straw from the jar. Since the atmosphere which is pushing on the bottom of the column of water in the straw is heavier than the water itself and the air above it, the water remains in the straw. Remove your finger from the top of the straw. Explain your observation.

ACTIVITY D

MATERIALS: large sink stopper (over 5" in diameter)

Wet the bottom of a large sink stopper with water and push it firmly against a smooth surface. Grasping the center knob, pull on the stopper. Why is it so difficult to remove? Lift the edge of the stopper and pull it away from the surface. Why can it be removed more easily this way?

ACTIVITY E

MATERIALS: plumber's plunger

Wet the bottom rim of a plumber's plunger and push it against a smooth surface forcing the air from the plunger. Why does it become so difficult to remove the plunger from the surface?

ACTIVITY F

MATERIALS: small-mouth can, stopper to fit can, nail, hammer

Use a small nail to punch a hole in the bottom of a can which has a small opening in the top that can be easily stoppered. Holding your finger over the nail hole in the bottom, fill the can with water and put the stopper firmly in the top. Remove your finger from the hole on the bottom of the can. While watching the hole, remove the stopper from the top for a few seconds and then put it back into place. Why does water flow through the nail hole only when the top of the can is opened?

Earth's Atmosphere

ACTIVITY G

MATERIALS: 2 bottles, 1 one-hole rubber stopper to fit the bottle,
1 two-hole rubber stopper to fit the bottle,
glass tubing

Insert a glass tube into each of the two rubber stoppers. Be sure to use a one-hole stopper and a two-hole stopper and exercise extreme caution when inserting the tube. Fill the bottles with water and put the stoppers with tubes into the two bottles. Using the glass tubes for straws, have two children race to see which one can drink the water from his bottle more rapidly. Why can the water be drawn from one jar easily whereas it is virtually impossible to get it from the other? (See Appendix A, "Working With Glass Tubing.")

ACTIVITY H

MATERIALS: 2 jars, rubber tube, water

Fill a jar with water and put it on the edge of a table. Put an empty jar on the floor. Fill a rubber tube with water and, pinching both ends closed with your fingers, put one end in the jar of water and the other end in the empty jar. Release both ends and observe. The air pressure on the surface of the water in the jar on the table forces the water up the tube.

ACTIVITY I

MATERIALS: drinking glass, water, tagboard

Fill a glass with water and place a piece of tagboard, a little larger than the top of the glass, over the top. Holding the tagboard firmly in place, carefully turn the glass upside down and remove your hand. What holds the tagboard in place and the water in the glass?

ACTIVITY J

MATERIALS: balance, volleyball, air pump and valve

Weigh a volleyball inflated and deflated. If weighed carefully, the ball will be found to weigh more when filled with air indicating that air has weight.

372. Air takes up space.

ACTIVITY A

MATERIALS: paper bag

Blow into a paper bag and fill it full of air. Seal it by holding it tightly with your hand. What keeps the bag from collapsing? Hold the open end of the bag to your lips and draw the air out of it. What causes the bag to collapse?

EARTH AND SPACE

ACTIVITY B

MATERIALS: glass tumbler, bowl, water, handkerchief

Stuff a handkerchief into a glass tumbler and push the tumbler, mouth down, into a bowl of water until the tumbler and handkerchief are submerged. Remove the tumbler and pull out the handkerchief revealing that it is dry. The air in the tumbler occupied space and prohibited the water from entering.



372 B

ACTIVITY C

MATERIALS: glass tumbler, bowl, water, cork

Float a cork in a bowl of water. Lower a glass tumbler, mouth downward, over the cork. Notice that the cork moves down. The air in the tumbler takes up space and will not allow the water to enter.

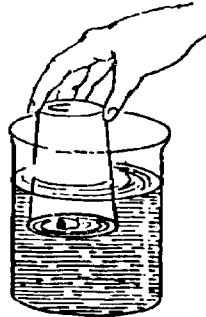

372 C

373. Air is present in soil.

ACTIVITY

MATERIALS: jar, soil, water

Fill a jar about half full of soil. Pour water into the jar on top of the soil. Notice the bubbles which rise up through the water. Where do they come from? Is there air in soil?

374. Water contains dissolved air.

ACTIVITY

MATERIALS: jar, water

Fill a jar with water and put it on a radiator or in some other warm place. After several minutes, notice the bubbles which form on the inside of the glass. Where do they come from? Is there air in water?

Earth's Atmosphere

375. Air is a mixture of gases.

ACTIVITY A

MATERIALS: references

Assign different groups within the class to gather information and report on the characteristics of each of the gases which make up the air. Discuss what might happen if the proportions of the various gases were altered.

ACTIVITY B

MATERIALS: references, paper, ruler

Locate information on what gases are in the air. Prepare a graph or chart showing the composition of air and the proportion of the different gases present.

ACTIVITY C

MATERIALS: 2 short, wide-mouthed jars, 1 lid for a jar, limewater

When limewater reacts with carbon dioxide, a white substance is formed. To determine if there is carbon dioxide in the air, partially fill two wide-mouth jars with freshly prepared limewater. Put the lid on one, leave the other open, and allow them to stand side by side for several days. Observe and draw conclusions from any changes.

376. The air which surrounds the earth is contained in a thin layer called the atmosphere.

ACTIVITY A

MATERIALS: globe, ruler

To illustrate the relative thickness of the earth's atmosphere, demonstrate with a ruler and a globe the comparative depth of the atmosphere. On most classroom globes, this thickness could amount to between a half inch and one inch.

ACTIVITY B

MATERIALS: pictures of astronauts on space walk

Refer to pictures of astronauts floating in space. Discuss why the astronauts are wearing sealed suits and must carry their oxygen supply with them.

ACTIVITY C

MATERIALS: references, poster paper, crayons

Have the children gather information about the three layers of the atmosphere. Prepare an illustrated cross-section diagram of the atmosphere including the troposphere, the stratosphere, and the ionosphere. On the diagram, show where weather occurs, where man has ventured, and other interesting information about what goes on in the ocean of air around us.

377. The climate of a region is represented by the average weather conditions.

ACTIVITY A

MATERIALS: thermometer, barometer

Keep detailed records of the weather over a period of about one week. In a sentence or two, summarize the general nature of the weather over that period of time. This general summary indicates the climate of your region. Weather, on the other hand, is what is taking place in the atmosphere at a particular moment.

ACTIVITY B

MATERIALS: almanac or local weather records

Refer to weather records which show the lowest and the highest tempera-

EARTH AND SPACE

tures recorded for a particular day of the year. Compare these to averages which have been compiled over the years. Use both sets of figures to differentiate between the overall climate, which is represented by averages, and the weather on particular days.

378. Average temperature is a basic factor in the climate of an area.

ACTIVITY

MATERIALS: thermometer

Keep an accurate record of the temperature at noon each day over a long period of time. Calculate the average for each week, the average for each month, and the overall average. These averages are indications of the climate.

379. Winds occur when warm air rises and cooler air moves in to replace it.

ACTIVITY A

MATERIALS: convection box, candle, wood splint

Hold a smoking splint of wood over one chimney and then over the second chimney of a convection box. Nothing of particular interest will occur. Light a candle, place it under one chimney of the convection box, and again put the smoking splint over each chimney. The smoke will be carried by the air currents which rise out of the chimney over the candle and move downward into the other chimney.

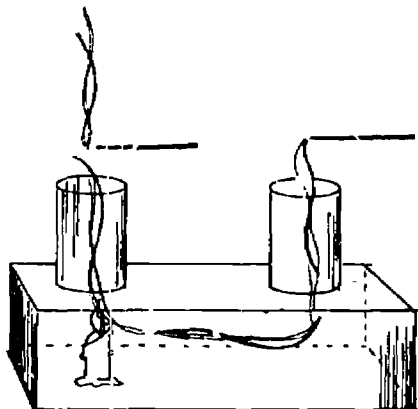

379 A

ACTIVITY B

MATERIALS: punk stick, matches, electric hot plate

The rising of hot air and the movement of air currents which produce winds can be demonstrated with a stick of punk and a hot plate. Hold the lighted punk above and in various positions around the hot plate and note the direction of wind currents by the movement of the smoke.

380. Humidity is an indication of the moisture in the air.

ACTIVITY

MATERIALS: bowl, white blotter paper, cobalt chloride, wax paper, spoon, tweezers, water

Cobalt chloride, a chemical which is pink when damp and blue when dry, can be used to make an indicator of changes in the amount of moisture in the air. Dissolve about two teaspoonfuls of cobalt chloride in about a half cup of water in a bowl. Using tweezers, dip small pieces of white blotter paper into the solution, allow them to soak, and place them on wax paper

Earth's Atmosphere

to dry. Observe them as the weather changes and notice the changes in color with changes in the amount of moisture in the air.

CAUTION: *Avoid touching the cobalt chloride. Wash thoroughly if any of this chemical comes in contact with you.*

381. Climate is influenced by the geography of an area.

ACTIVITY A

MATERIALS: map of North Carolina, references

Discuss how the climate varies across North Carolina and pick out the geographic factors which cause this variation.

ACTIVITY B

MATERIALS: maps, references

Have groups of students select various geographic areas for a climate study. From references, have them gather information about the climate of the area they are studying and determine how altitude, latitude, nearness to water, mountain ranges, ocean currents, winds, and other factors influence this climate.

382. Large bodies of water can influence the climate of an area.

ACTIVITY A

MATERIALS: 2 cake pans, soil, water, thermometer

Fill a pan with soil and another pan with water at the same temperature as the soil. Put them in the sun for a brief period of time and then measure the temperature of the soil and the temperature of the water. How would the presence of a body of water affect the temperature of a region?

ACTIVITY B

MATERIALS: 2 cake pans, soil, water, refrigerator, thermometer

Fill a pan with soil and another pan with water at the same temperature as the soil. Put them in a refrigerator for a brief period of time and then measure the temperature of each. How would the presence of a body of water affect the temperature of a region?

383. Ocean currents can affect climate by bringing warm or cold water into an area.

ACTIVITY

MATERIALS: 2 identical jars, file card, hot water, cold water, food coloring

To illustrate ocean currents, fill a jar with hot water and another jar with cold water. Color the hot water with food coloring. Cover the jar of cold water with a file card and invert it so it is mouth to mouth with the jar of hot water with the card between them. Slip the card from between the jars and observe the currents of water.

384. Uneven heating of the earth's surface can produce wind.

ACTIVITY

MATERIALS: 2 water glasses, 2 thermometers, soil, water

If one part of the earth's surface becomes warmer than an adjacent area, the air above the warmer part will be heated, rise, and cause wind. Such a difference can occur where land and water come into contact with one another.

To illustrate the difference in the warming of soil and water by the sun

EARTH AND SPACE

fill one water glass with soil and another with water, put a thermometer in each, and place them in the sunlight. Record the temperatures at regular time intervals. Notice that the temperature of the soil rises faster than that of the water. After both temperatures have risen, place both samples in a cool, shaded place. Notice that the temperature of the soil goes down more rapidly than that of the water. Discuss how these changes cause land and sea breezes.

- 385. The altitude of an area affects its climate.**

ACTIVITY

MATERIALS: maps, references (encyclopedias, almanacs, etc.)

Locate on topographical maps areas of the world which are at high altitudes. Gather information about the climate of these areas. How does altitude affect climate?

- 386. Climate is determined by the topographical features of a region.**

ACTIVITY

MATERIALS: map, references

Provide the children with the map of a region which contains detailed information about topographical features. From this information, have them predict the type of climate which they would expect to find. Consult references to determine whether these predictions are accurate.

- 387. There are many different kinds of weather.**

ACTIVITY A

MATERIALS: poster paper, crayon

Prepare a list of words which relate to weather. Add new words to this list as they are encountered during your study of weather.

ACTIVITY B

MATERIALS: calendar, paper, scissors, paste, crayons

Devise small cutout symbols to represent various types of weather. Each day, paste one or more on a calendar to record the weather during the day.

- 388. Weather affects the way we dress.**

ACTIVITY

MATERIALS: doll, doll clothes for all type of weather

Obtain a doll and doll clothes which are suitable for all kinds of weather. Each day, dress the doll in the clothes that are most appropriate for the weather outside.

- 389. Weather affects the way we play.**

ACTIVITY

MATERIALS: bulletin board, paper, crayons

Have each child draw a picture of the kind of games which he plays during a particular kind of weather. Represent rain, snow, hot, cold, cloudy, sunny, and other types of weather that you can think of. Display these drawings on a bulletin board and discuss.

Earth's Atmosphere

390. Weather affects the work we do.

ACTIVITY

MATERIALS: bulletin board, paper, crayons

Have each child draw a picture to represent the kind of work which he does during a particular kind of weather. Shoveling snow, planting a garden, raking leaves, cutting grass, watering the garden, etc., can be illustrated. Display these drawings on a bulletin board and discuss.

391. The movement of air masses has a marked effect on the weather.

ACTIVITY

MATERIALS: newspaper weather maps, references

Locate on a weather map the various types of fronts which are associated with air masses. Consult references to find out what types of weather are usually associated with each kind of front. Listen to weather reports for information on fronts which may be passing through your area. As they do, see if typical weather patterns are produced.

392. Air pressure changes. The air pressure and its changes can be measured by a barometer.

ACTIVITY

MATERIALS: bottle with eyedropper in lid, water, water soluble ink, rubber band, scissors

Changes in the air masses above us which produce changes in the weather can be detected with a barometer. A simple barometer can be constructed by filling a bottle which has an eyedropper in the lid about one-third full of a solution of ink in water. Cut off the top of the rubber nipple on the eyedropper and screw the lid tightly on the bottle. Add additional colored water through the top of the dropper until the level inside of the dropper is halfway between the water level in the bottle and the top of the bottle. Wrap a rubber band around the outside of the bottle to show the level of the water in the dropper. Place the bottle at a location in the room where the temperature is fairly constant. Observe changes in the water level each day and see if you can detect any relationship between these changes and changes in the weather.

393. Weather forecasts are made on the basis of information which is collected about the atmosphere.

ACTIVITY A

Visit a nearby weather station. List the instruments which you see that are used to observe and make measurements of the atmosphere.

ACTIVITY B

MATERIALS: daily weather map from the U. S. Weather Bureau, references

Check carefully over a weather map and list the different types of weather information which are recorded on it. How does each bit of information contribute to making an accurate forecast?

ACTIVITY C

MATERIALS: references

Many books about weather include instructions on how to make weather instruments. Locate such books in the library and make a classroom weather station.

EARTH AND SPACE

394. Precipitation can be measured with a rain gauge.

ACTIVITY

MATERIALS: rain gauge

Set up a rain gauge on the school grounds. Measure and record the amount of precipitation every twenty-four hours.

395. Weather forecasting is important to man.

ACTIVITY

MATERIALS: paper, crayons, bulletin board

Draw pictures of activities for which accurate weather forecasting is essential or desirable. Airplane flights, farm activities, picnics and outdoor sports events are but a few examples.

396. The earth's water passes through a continuous cycle of evaporation and condensation.

ACTIVITY A

MATERIALS: transparent Pyrex glass pan and lid, hot plate, water

Fill a Pyrex pan about half full of water, put on a lid, and boil the water gently on an electric hot plate. Notice the water cycle which is taking place in the pan. A similar cycle takes place in nature at a slower rate and to a less obvious degree.

ACTIVITY B

MATERIALS: jar with lid, warm water, ice

Fill a jar about one quarter full with warm water. Place a lid loosely on the top of the jar and put a piece of ice on top of the lid. Look into the jar and watch moisture form on the inside of the lid and fall back down. Observe the cycle as it takes place in the jar.

397. Cooling of water vapor causes it to condense to a liquid.

ACTIVITY

MATERIALS: 2 jars with lids, water, ice cubes

The condensation of water vapor can be demonstrated by pouring warm water into two jars until both are about half full. Put the lid on one of them, fill the other with ice cubes, and put the lid on it. Notice that water vapor condenses on the jar with ice in it but not on the other. The jar without ice serves as a control to show that the water did not seep through the jar.

398. The temperature at which water vapor condenses to a liquid is called the "dew point."

ACTIVITY

MATERIALS: large can, jar, ice, water at room temperature

The temperature at which water vapor condenses into a liquid, the "dew point," can be determined by a simple experiment. Fill a large can about half full of water that is at room temperature. Put a thermometer into the water in the can and keep a constant record of the temperature. Slowly add ice to the warm water until moisture begins to form on the outside of the can. Immediately note the temperature at which the moisture is formed. This temperature is the "dew point."

Earth's Atmosphere

399. The amount of water in the air is important in weather changes.

ACTIVITY

MATERIALS: wet and dry bulb thermometers, relative humidity chart

Read the temperatures on wet and dry bulb thermometers and consult a chart to determine the relative humidity. Relative humidity is the ratio of the amount of water in the air to the amount of water which can exist in the air at its present temperature.

400. Precipitation can exist in a variety of forms.

ACTIVITY

MATERIALS: references

List all forms of precipitation which the children have seen. Assign committees to report and, if possible, demonstrate how each type of precipitation is formed.

401. A cloud is formed when moisture in the air condenses.

ACTIVITY A

MATERIALS: 3 large jars, 3 small jars, damp soil, water, fresh, green lettuce leaves

In order for clouds to form, the air must contain moisture. Some of the ways in which this moisture gets into the air can be illustrated by putting water in one of the small jars, moist soil in a second, and lettuce leaves in a third. Place a large jar, mouth downward, over each of the three and allow them to stand over night. The following morning, moisture should be detected on the inside of the large jars. If it is not, transfer the jars to a cool place where the moisture will condense more rapidly. It should become apparent that sources of moisture in the air include water, moist soil, and green plants.

ACTIVITY B

MATERIALS: milk bottle, hot water, ice cubes

Pour about a cup of hot water into a milk bottle. Put an ice cube in the mouth of the bottle. Water will evaporate from the bottom of the bottle. A cloud will be formed when the water vapor condenses by losing heat to the ice cube.

402. Rain is formed when water vapor condenses into drops of water.

ACTIVITY

MATERIALS: aquarium or large jar, glass

Half fill an aquarium or jar with water and cover it with glass. Place it in the sunlight. The sun warms the water causing it to evaporate. When the water vapor comes into contact with the cool glass top, it changes back into liquid water again and drops fall back into the water below.

403. Snow is formed when water vapor in the clouds is frozen directly into ice crystals.

ACTIVITY A

MATERIALS: jar, thermometer, snow

Pack snow around a thermometer inside a jar. Determine the temperature of the solid snow and the temperature at which the snow becomes water.

EARTH AND SPACE

ACTIVITY B

MATERIALS: jar, snow

Fill a jar with snow and watch it melt. Notice that the amount of water in the jar is much less than the original amount of snow. Judge how much larger a volume is occupied by the snow than by the water it forms.

404. Sleet is frozen raindrops.

ACTIVITY

MATERIALS: jar, ice, salt, water, test tube

To demonstrate how raindrops freeze in cold surroundings, put a few drops of water in a test tube and put the test tube into a jar of cracked ice and salt. The drops inside the test tube will freeze.

405. Hail is formed when raindrops move through layers of icy air. Several layers of ice can build up on hailstones.

ACTIVITY

MATERIALS: hailstones

When a hailstorm occurs, collect several large hailstones and store them in a freezer. Have the children examine them and try to detect the layers of ice which were formed.

406. Dew is formed when water vapor in the air condenses to water.

ACTIVITY

MATERIALS: tin can, ice, water

Pour ice water into a tin can. Observe the formation of moisture on the outside of the can. Compare this moisture with dew.

407. Frost is formed when water vapor in the air condenses to form ice crystals.

ACTIVITY

MATERIALS: tin can, ice, salt

Prepare a mixture of crushed ice and salt and put it into a tin can. Add more ice and salt as needed. Notice the frost forming on the outside of the can.

408. Fog is a cloud of tiny water droplets which is in contact with or near the ground.

ACTIVITY

MATERIALS: milk bottle, hot water, alcohol, ice cube

Fill a milk bottle with hot water and then pour out all but about an inch of water. Add a small amount of alcohol. Place a cube of ice at the mouth of the bottle. Fog will form in the bottle.

C. Space

409. The sun is a hot star which gives off heat and light.

ACTIVITY A

MATERIALS: window shades

At a time of the day when the sun is shining into the classroom, raise all of the window shades for about a minute. Then pull them down for about a minute. Ask the children to name two things that we get from the sun.

ACTIVITY B

MATERIALS: blindfold

On a warm day when the sun is shining in the window, blindfold one child and have another child lead him around the room. Have the child being led tell when he is in the sunshine and when he is not. He will be able to tell because of the heat which the sun gives off.

410. The sun is the center of the solar system and the source of most of its energy.

ACTIVITY A

MATERIALS: references, poster paper, crayons

What information has man gathered about the sun? What is the sun's size, shape, distance from the earth, content, temperature, etc.? Gather as much information as possible about the sun and prepare posters containing detailed pictures of the sun and the information which was collected.

ACTIVITY B

Make reservations to visit the Morehead Planetarium at Chapel Hill, North Carolina. In addition to the other displays, exhibits, and instructional programs, arrange to see the model of the solar system. Notice the prominent place of the sun in the solar system and how it is the source of energy for all of the planets which orbit around it.

411. The relative sizes of the sun, moon, or stars cannot be determined by just looking at them because of the different distances to them.

ACTIVITY

MATERIALS: scissors, cardboard, compass (circle drawing), clay, table

The sun and the moon appear to be the same size in the sky even though the sun is hundreds of times larger. The reason for this can be seen by cutting out three cardboard circles—two, three, and four inches in diameter. Using the modeling clay, stand the two inch circle two feet from the edge of the table, the three inch circle three feet from the edge and the four inch circle four feet from the edge. Bend over and look at the three circles from the edge of the table. What conclusions can you draw about apparent relative sizes?

412. The sun's energy is believed to be produced by nuclear fusion.

ACTIVITY

MATERIALS: references, clay, paper, marbles

Consult references to find out what nuclear fusion reaction is believed to take place on the sun. Illustrate this reaction with marbles, clay models, and drawings.

EARTH AND SPACE

413. The sun provides the earth with heat and light.

ACTIVITY

MATERIALS: lamp with bulb over 100 watts, globe, 2 thermometers

Darken the room. In the coolest corner of the room, place a globe about a foot away from a lighted light bulb. Position a thermometer in a location where the light from the lamp is striking the globe and put another thermometer on the dark side of the globe. Compare temperatures. Discuss the importance of the sun as a source of heat and light.

414. Night and day result from the rotation of the earth on its axis.

ACTIVITY A

MATERIALS: lamp

Darken the classroom. Place a lamp in the center of the room and have the children stand in a circle around it. If the lamp represents the sun and each child represents the earth, as a child faces the lamp he can see the light as in the daytime. Have the children turn their backs to the lamp. Now they are looking into the dark and represent night. If the children rotate slowly in place, they can gain an awareness of day, sunset, night, and sunrise.

ACTIVITY B

MATERIALS: lamp, globe

Darken the room and place a lamp a few feet away from a globe. Rotate the globe on its axis. Assuming that the light from the bulb represents the light of the sun, discuss the reasons for night and day.

415. A year is the time required for the earth to make one complete revolution around the sun.

ACTIVITY

MATERIALS: lamp, globe

Darken the room and place a lighted lamp in the center. Using the lamp to represent the sun and a globe to represent the earth, walk around the room one time and return to the spot where you started. While doing this, spin the globe on its axis. One complete circling of the sun by the earth represents a year.

416. The seasons of the year are caused by the tilt of the earth and its movement around the sun.

ACTIVITY A

MATERIALS: lamp, globe

Place a lamp representing the sun in the center of a table in a dark room. Place a globe on the table with the tilted top pointing north. Rotate the globe so that the light of the sun strikes North Carolina. Notice the angle at which the light strikes the place where you live. Move the globe one-fourth of the way around the table with the tilted top still pointing

north and with North Carolina facing the light. Repeat your observation by placing the globe on each of the other two sides of the table, having the top tilted to the north and North Carolina facing the light each time. Summer is represented when the light strikes North Carolina most directly and winter is represented when the light strikes the State at the most indirect angle.

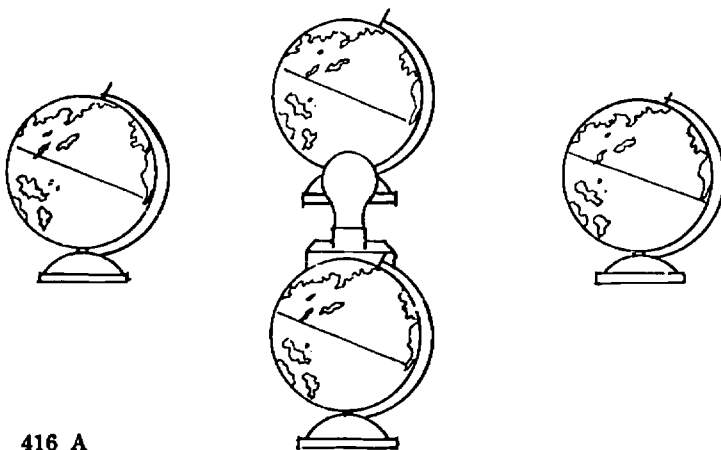

416 A

ACTIVITY B

MATERIALS: calendar showing entire year on one page, crayons, clay, long nails, thread, board (about 2' x 2'), references

Prepare a display about seasons. Using four different colors, lightly color the portions of a calendar during which the four seasons occur. To illustrate the position of the earth during each of these seasons, make a clay model of the sun and put it in the center of a board. Make four clay models of the earth on nails with a piece of thread around the center of each to represent the equator. Drive the nails in the board in the proper positions and angles to show the earth's position during each of the four seasons. Label the model which represents each season.

417. The sun is important to all life on the earth.

ACTIVITY

MATERIALS: chalkboard

Have the children list some of the things which are essential for life on the earth. Go over the list and discuss each one with regard to whether its existence is dependent upon the sun. Discuss the importance of the sun to all life.

418. The sun is necessary to have life on the earth.

ACTIVITY

MATERIALS: poster paper, crayon

List the things which we would not have and the ways in which the earth would be different if the sun did not exist. It should soon become apparent that there would be no life on a barren earth.

EARTH AND SPACE

419. The moon is a sphere which orbits around the earth.

ACTIVITY

MATERIALS: binoculars or telescope, clay

Have the children look at the moon with binoculars or a telescope and make clay models of the type of surface which they see.

420. The moon shines by reflecting light.

ACTIVITY

MATERIALS: lamp, white ball

Darken the room. Sit with a lighted lamp, representing the sun, behind you. Have someone hold a white ball in front of you. You can see the white ball just as you can see the moon, because of the light from the sun which it reflects.

421. The moon is smaller than the earth.

ACTIVITY

MATERIALS: Ping-Pong ball, knife, modeling clay, ruler

Although the earth has a diameter which is four times the diameter of the moon, the size of the earth is about sixty times as large as the moon. This can be demonstrated by representing the earth with a Ping-Pong ball (about one inch in diameter) and the moon by a clay ball shaped to be about a quarter inch in diameter. Make several quarter-inch balls out of clay. Cut a hole in one side of the Ping-Pong ball and see how many of the quarter-inch balls fit inside it.

422. The moon orbits around the earth.

ACTIVITY

MATERIALS: 3 children, paper, crayon

With pieces of paper, label one child the sun, another child the earth, and still another child the moon. Place the child representing the sun in the center of the room. Have the child representing the earth move slowly in a circle, about ten feet in radius, around the sun. Have the child representing the moon move rapidly in a small circle around the moving "earth."

423. It takes one month for the moon to orbit the earth.

ACTIVITY

MATERIALS: lamp, references

Darken the room and place a single light source in one corner. This light represents the sun. Have one child stand in the center of the room and turn in place. This child represents the earth and each turn represents one day. Have another child move slowly in a circle around the earth while always facing the earth. This child represents the moon. Consult references to determine the speed at which the earth should turn in relation to the speed of the moon around it. Have different children take the positions of earth and moon so that each may experience the perspective of both positions.

424. The phases of the moon result from the relative positions of the sun, the moon, and the earth.

ACTIVITY A

MATERIALS: flashlight, white ball

The moon shines by reflecting the light of the sun. To illustrate the reason for the different phases of the moon, use a flashlight to represent the sun and a white ball to represent the moon. In a dark room, look at the white ball while someone shines the flashlight on it from various angles. All of the phases of the moon will be represented depending upon the angle from which the flashlight is directed at the ball.

ACTIVITY B

MATERIALS: lamp, white ball

Darken the room except for a single lamp in one corner. Stand in the center of the room and have someone move around you with a large white ball. Notice how the light strikes the ball in various positions. Compare the appearance of the lighted portion of the ball to the various phases of the moon and discuss the relationship.

ACTIVITY C

MATERIALS: pencil, paper

Prepare a calendar on a sheet of paper with a block of space for each day of the month. Each night that the moon is visible during the month, draw its shape in the appropriate block. Notice the changes. Discuss these changes in terms of the relative positions of the sun, moon, and earth.

425. The gravitational pull of the moon causes tides.

ACTIVITY

MATERIALS: references, globe, ball

Consult references for information on how the moon influences tides. Use a ball to represent the moon and a globe to represent the earth. Hold the ball in various positions relative to the globe and discuss how tides on the earth would be influenced by the moon in each of these positions.

EARTH AND SPACE

426. An eclipse of the moon is caused by the shadow of the earth falling on the moon.

ACTIVITY

MATERIALS: lamp, tennis ball, volleyball

Using a light for the sun, a tennis ball for the moon, and a volleyball for the earth, move them into a position where the shadow of the earth falls on the moon thus causing an eclipse of the moon.

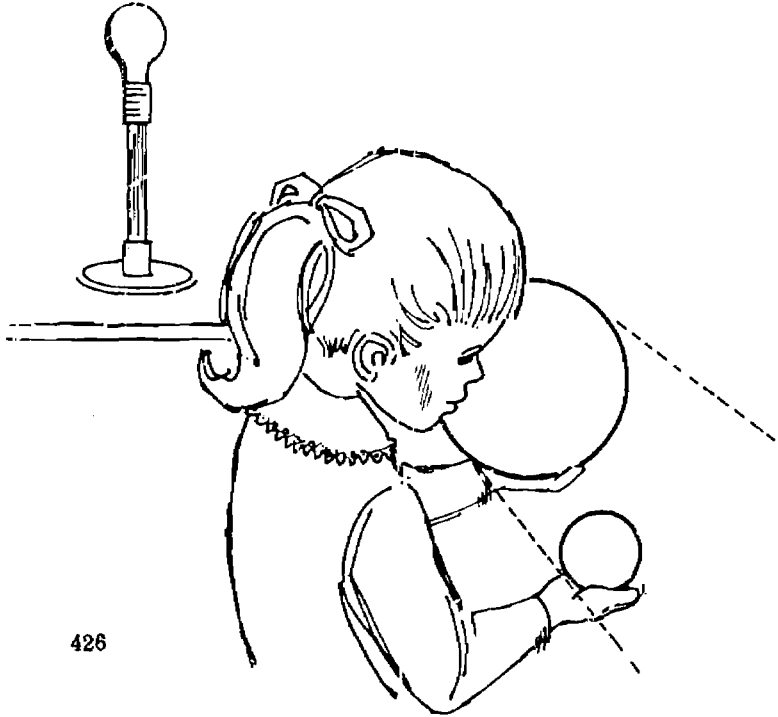

426

427. The earth and other planets orbit around the sun.

ACTIVITY

MATERIALS: large ball, paper, crayon, references

Consult references to find out: the names of the planets and the order of their distances from the sun. Print the name of each planet on a separate sheet of paper and assign the name of each planet to a different child. In a large room or on the school grounds, place one child with a ball to represent the sun. Around this child, place the children who represent the planets in the order of their relative distance from the sun. On a given signal, have the children begin walking in a circle around the sun. Have all of them move in the same direction and keep their relative positions. A variety of observations can be made about the movement of planets about the sun.

428. The earth is one of nine known planets in our solar system.

ACTIVITY A

MATERIALS: references

Form two teams to debate whether or not there is life on other planets. Have one team gather all possible information to support the belief that there is life and the other team secure information which would indicate that there is not.

ACTIVITY B

MATERIALS: cardboard, scissors, thread, references, clay

Cut a large circular piece of cardboard. Prepare clay models of the sun and each of the planets. Suspend the model of the sun with thread from the center of the cardboard disc, and suspend the planets at relative distances around the sun. Consult references for information on the relative positions of the planets. At the point where the threads come in contact with the cardboard, label with the names of the planets.

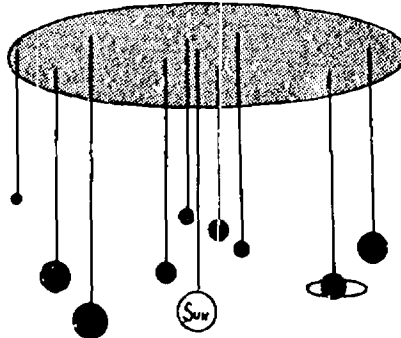

428 B

ACTIVITY C

MATERIALS: references

Consult references for the names of the other eight planets and the background and previous use of each of the names.

429. Comets are heavenly bodies which travel around the sun.

ACTIVITY

MATERIALS: references, poster paper, colored paper, paste

Consult references regarding comets. Gather information about the make-up of comets and the nature of their orbits. On a piece of poster paper, use colored paper to represent the moon and planets and paste them in appropriate positions to represent our solar system. Draw an orbit of a comet on the paper. Cut out several representations of the comet from colored paper and paste them in position around the orbit. Consult your references carefully and be sure that the tail of the comet is pointing in the right direction in each instance.

EARTH AND SPACE

- 430. Meteors are pieces of material from outer space which burn when they move into the earth's atmosphere.**

ACTIVITY

Have the children look on a clear night for meteors (often called "shooting stars"). Record and report to the class the next day the time that each meteor was seen, the part of the sky in which it was observed, the length of its path in relation to the sky, its brightness, and other information of interest. Mid-October is a good time for this observation.

- 431. Meteorites are objects from space which strike the earth.**

ACTIVITY

MATERIALS: references

Consult references to gain information about the nature and composition of meteorites. Locate pictures of meteorites. Locate pictures of the effects of some of the large meteorites which have struck the earth. How big are the largest meteorites which have struck the earth?

- 432. Stars are like our sun but much farther away.**

ACTIVITY

MATERIALS: paper, scissors, compass for drawing circles

Cut out several circular discs about six inches in diameter. Take the class into the hall or to the school grounds. Have one child hold a disc a few feet in front of the children and have three or four other children hold discs at greater distances. Notice the apparent size of each. Use this comparison to point out that some stars are like our sun and that many other are larger than the sun but look very tiny because of distance.

- 433. Stars can be seen in the darkness of the night sky but not in the brightness of the daytime sky.**

ACTIVITY

MATERIALS: candle, matches, luminous dial clock

To illustrate why we see the stars at night but not during the day, pull the shades, turn off all the lights, and light a candle. Notice how bright it is. Now turn on the lights, raise the shades, and compare its brightness to what it was in the dark. Carry out the same procedure with a luminous dial clock.

- 434. Some stars are in groups called constellations.**

ACTIVITY A

MATERIALS: star chart

Using a star chart or with the help of someone familiar with the stars, locate some of the most prominent constellations in the night sky.

ACTIVITY B

MATERIALS: cardboard tubes, aluminum foil, rubber band, pin

Cover one end of a cardboard tube with aluminum foil held in place with a rubber band. With a pin punch holes in the foil in a pattern to represent a constellation. Prepare a tube for each constellation which you can think of and label each tube with the name of the constellation. By looking through the tube toward a light, the pattern of the constellation becomes visible in the dark tube.

ACTIVITY C

MATERIALS: slide projector, cardboard, pins, scissors

Cut out several squares of cardboard to fit a slide projector. Put patterns of the constellations on the cards by punching holes in them with pins. Project the constellations on a screen and use them for discussion and drill.

ACTIVITY D

MATERIALS: black paper, white paint

Using spots of white paint on black construction paper, make star maps of some of the constellations and put them on the bulletin board for others to identify.

ACTIVITY E

MATERIALS: paper, thread, tape

Although the stars in a particular constellation appear to be all at the same distance, in reality, their distances from the earth vary greatly. This can be illustrated by cutting out paper stars and hanging them from the ceiling in the pattern of a constellation but with different lengths of thread. In this way it is possible to look up from below and see the pattern of a constellation, and then to look at the same stars from across the room and see that they do not exist on an even plane.

ACTIVITY F

MATERIALS: black umbrella, white paint, block of wood

Attach a black umbrella to a base by putting its handle into a hole in a block of wood. As you learn about a new constellation, mark it in its relative position with white paint on the inside of the umbrella.

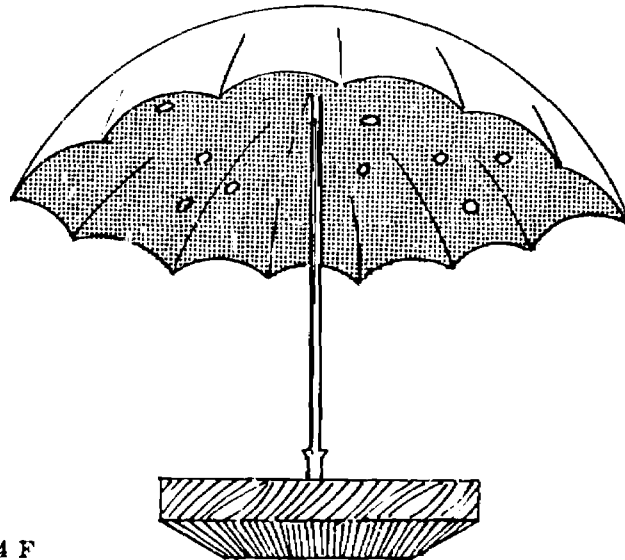

434 F

ACTIVITY G

MATERIALS: books about stars

Refer to books on astronomy and determine why various constellations were named as they are and learn the stories which relate to these names.

EARTH AND SPACE

435. Galaxies are vast systems of stars.

ACTIVITY

MATERIALS: references, poster paper, crayons, clay

Consult references to gain information about the galaxy in which we live. Prepare a map of our galaxy indicating the position of our solar system. On a clear dark night, locate the Milky Way in the sky and indicate on the map the stars at which you are probably looking. What is the name of the galaxy in which we live? What is the shape of the galaxy in which we live? Prepare clay models which would illustrate the shapes of different galaxies.

436. Special instruments are used to study the stars, moon, and planets.

ACTIVITY A

MATERIALS: binoculars or telescope

Examine the heavens with binoculars or a telescope. Try to locate stars which you cannot see with your unaided eye. Examine the moon and planets for features which are not visible without magnification.

CAUTION: *Never look directly at the sun.*

ACTIVITY B

MATERIALS: camera, tripod or other firm support

Experiment by taking pictures of the heavens. Your camera must be mounted on a firm support. If the shutter is left open for several hours, star trails or the path of the moon can be photographed.

437. Many scientists have contributed to our present knowledge of rockets.

ACTIVITY

MATERIALS: books about rockets

Have the children locate information on Konstantin Tsiolkovsky, Robert Goddard, Wernher von Braun, and other scientists who have contributed to the development of rockets. Discuss the part which each of these men has played.

438. A variety of rockets have been designed to accomplish different purposes.

ACTIVITY

Have the children gather as many pictures and as much information as they can about the various rockets which are being used in our space program. Prepare a chart on each rocket reported including such information as its size and uses.

439. Rockets are propelled in one direction by exerting a force in the opposite direction.

ACTIVITY A

MATERIALS: skateboard, basketball

Have a child kneel on a skateboard holding a basketball. When he throws the basketball as hard as he can, the action of the ball in one direction causes him to move in the opposite direction. Rockets operate on the same principle.

ACTIVITY B

MATERIALS: water hose

Adjust a hose nozzle to produce a stream of water at maximum pressure. Place the hose on the ground and turn on the water faucet to full capacity. The nozzle will move around on the ground because the action of the water in one direction causes a reaction of the nozzle in the other direction. This is the same principle by which a rocket is propelled.

440. An action in one direction causes an equal reaction in the opposite direction.

ACTIVITY A

MATERIALS: balloon

Blow up a balloon and release it. Observe how it darts about. The action of the air moving in one direction causes a reaction in the form of the movement of the balloon in the other direction.

ACTIVITY B

MATERIALS: large pan of water, balloon, rubber band, medicine dropper

Fasten the glass tube from a medicine dropper in the neck of a balloon with a rubber band. Blow up the balloon and release it in a large pan of water. The action of the air moving in one direction causes a reaction in the form of the movement of the balloon in the other direction.

ACTIVITY C

MATERIALS: 2 pairs of skates or 2 skateboards

To show that action in one direction causes a reaction in the other, have two boys on skates or skateboards face each other with the palms of one's hands touching the palms of the other. On a signal, have both boys push and notice the movement. Now have just one boy try to push the other away without moving himself and then have the other boy try the same thing. The reaction to a definite action should be observed each time.

CAUTION: Assign a boy to assist each boy on skates in case he loses his balance.

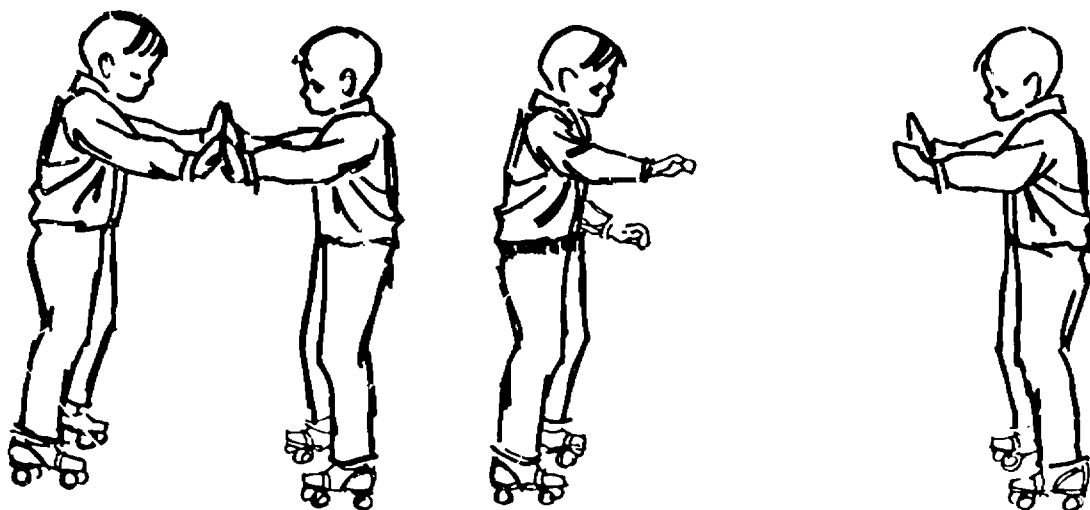

EARTH AND SPACE

441. Earth satellites are designed in many forms to accomplish a variety of purposes.

ACTIVITY

MATERIALS: notebook

Have the class start a log of satellite launchings and space probes. In a special notebook, have them record the date, purpose, and other pertinent information about such probes as they happen. Newspaper clippings can also be entered under each record.

442. A satellite will orbit the earth if the force moving it away from the earth equals the force drawing it to the earth.

ACTIVITY

MATERIALS: ball, table, chalk, chalkboard

To illustrate how a satellite can go into orbit without falling to the earth, gently roll a ball off of a table and put a chalk mark on the floor where it falls. Roll it off two or three more times pushing it harder each time and marking the place where it lands. On the chalkboard, draw a picture of the earth with a table located at the north pole. Add to the drawing the paths that the balls followed as they rolled from the table. Discuss and draw what would happen as the ball is rolled harder and harder. Show how the ball would eventually go into orbit.

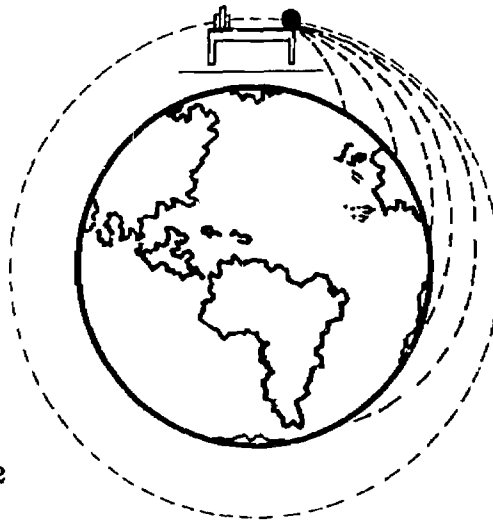

443. Objects which travel in a circular path tend to move outward because of an outward force called centrifugal force, but they are held in their circular path by an inward force called centripetal force.

ACTIVITY

MATERIALS: small pail, water

As things move in a circular path, they tend to move outward. Demonstrate this by half filling a small pail with water. Holding the handle firmly, swing the pail in a circular path which goes over your head and below your knees. Swing the pail smoothly, rapidly, and without jerking. The water does not spill due to its tendency to move outward (centrifugal force). It is prevented from moving outward from the circular path by the bottom of the bucket and the centripetal force of your arm holding the bucket.

Space

444. Astronauts are trained for space exploration.

ACTIVITY

MATERIALS: books on space exploration, pictures of astronauts, bulletin board

Have the children find the names of the American astronauts. Locate pictures of these astronauts and prepare a bulletin board about them. Pictures and information can be obtained by writing to the National Aeronautics and Space Administration.

445. Weightlessness is a sensation of falling freely through space.

ACTIVITY

MATERIALS: table

In order to get a momentary feeling of weightlessness, jump several times from a low table. Describe the feeling which you have when you are falling.

EVALUATION

Evaluative procedures in an elementary school science program serve several purposes by examining the knowledge, the attitudes, the skills, and the behavior of children resulting from their science instruction. Major purposes of evaluation include the following:

- Assessing student progress
- Determining the degree to which course objectives are being attained
- Providing diagnostic information for use in working with individual pupils
- Enabling pupils to see their progress toward established goals
- Affording guidance for individualized instruction

To achieve these ends, evaluation should—

- Be based upon the objectives established for the course
- Assess student achievement in understanding course content
- Measure student performance in useful skills
- Examine student attitudes toward science

Instruments commonly used in assessing students' achievement in understanding course content include the following:

Objective tests

- True-false items
- Fill-in items
- Completion items
- Multiple choice items
- Matching items

Essay tests

Standardized tests

Procedures for measuring student performance in useful skills include the following:

- Examining student records
- Oral testing
- Performance testing
- Observing student behavior
- Appraising projects

Students' attitudes toward science can be discerned through—

- Student conferences
- Parent conferences
- Examination of student records
- Standardized attitude inventories
- Student autobiographies or other compositions
- Student self-rating

Develop a definite plan for evaluating the progress of children which is consistent with the overall program of evaluation in your school. See Appendix E for an Evaluation Checklist. Insert a copy of this plan in the back of this bulletin in the manner suggested on page 196.

APPENDIX A

Useful Techniques for Teaching Elementary School Science

The following procedures were prepared to assist teachers in techniques that are considered useful in carrying out an effective elementary science instructional program.

PREPARING AND CONDUCTING FIELD TRIPS

Field trips are an essential feature of an elementary science instructional program. Not only do they provide a background in science but they also enable children to gain the broad experiences so essential to the learning of reading and other basic skills. The following suggestions are designed to assist in developing and carrying out an effective field trip:

1. Carefully define the purpose of the trip. Make certain that everyone involved understands the objectives clearly.
2. Make a preliminary trip to become acquainted with essential details and to insure that the objectives of the trip can be met.
3. Plan such details as gaining parental permission, transportation, scheduling, clearance through the school office, necessary guides, safety provisions, meals, equipment, materials, and money which each child should have.
4. Pay particular attention to describing to the children the type of behavior which will be expected of them to insure a pleasant and informative trip.
5. To the extent that it is possible, plan every phase of the trip, making certain that attention is given to the time allotted and the size of the group. Care should be taken to avoid attempting too much within a limited time. Certain phases of the trip may not be suitable for the entire group, making it desirable to designate specific assignments to individuals and small groups.
6. Follow up the trip with appropriate discussions, reports, and applications of what was seen and learned.
7. Relate the science field trip to other phases of the instructional program. Valuable instructional experiences in social studies, arithmetic, reading, writing, note-taking, letter-writing, and in a variety of other areas can be related to a science field trip.

Additional Reference

Hurd, Paul DeHart. HOW TO TEACH SCIENCE THROUGH FIELD STUDIES. National Science Teachers Association, Washington, D. C. 1965. 35¢.

Suggested Field Trips

Corundum Hill, Franklin, North Carolina

Features: Gem mines
Minerals

Write to Corundum Hill Enterprises, Inc. for information.

Coweeta Hydrologic Laboratory, P. O. Box 601, Franklin, North Carolina
28734

Food processing plants

Furniture factories

Granite quarries, Mount Airy, North Carolina

Highlands Biological Station, Highlands, North Carolina

Linville Falls, Linville Falls, North Carolina

Local gardens

Local sewage plant

Local water purification plants

Marine Museum, Morehead City, North Carolina

Mica mines, Spruce Pine, North Carolina

Morehead Planetarium, Chapel Hill, North Carolina

Features: Public programs
Graded school programs
General school programs
Science Exhibits
Planet room

Write to the Morehead Planetarium for additional information and reservations.

National forests

North Carolina: State Museum of Natural History

P.O. Box 2281

Raleigh, North Carolina 27602

Parks: local, state, national

Pet shops

Phosphate mines, Aurora, North Carolina

Saline Water Research Station, Wrightsville Beach, North Carolina

Telephone company

Tobacco processing and cigarette plants

Tote-Em-In Zoo, Wilmington, North Carolina

CARING FOR LIVING SPECIMENS IN THE CLASSROOM

The following information is provided to assist in obtaining and keeping living things for use in the classroom.

Animal	Habitat	Controlled Habitat	Food	Cause of Failure	Remarks
Ants	Common on the grounds everywhere	Miniature vivarium, tight fitting top	Sugar Fat Honey-water	Development of molds Lack of water	
Caterpillars	Common everywhere	Insect cage, Glass jar with screened top Screened box	Plenty of fresh leaves from plant specimen on which found	Lack of food and moisture	Should be isolated
Insect eggs	Found on trees and bushes in fall and winter	Fasten outside window. If kept inside, sprinkle lightly with water each week.	None	Lack of moisture Too warm	
Crayfish and Shrimp	Ponds	Semi-aquatic in balanced aquarium	Earthworms Fresh meat	Overcrowding Drowning	Provide rocks or other hiding places
Earthworms	Gardens or lawns Rich soil	18" of soil, leaves, grass, and sphagnum moss. Wooden container	Lettuce Vegetation Leaves	Over-stocking Too much heat Lack of moisture	Keep cool Keep tub covered
Frogs	Ponds	Semi-aquatic aquarium	Mealworms Flies Earthworms	Too sudden change of temperature	Screen top of tank for ventilation
Toads	Woodlands Gardens	Woodland aquarium or semi-aquatic terrarium	Mealworms Flies Insects	Lack of moisture	Provide leaves and branches for shelter Do not keep with salamanders
Frog eggs and Toad eggs	Ponds	Balanced aquarium in pond water	None	Chlorine in tap water Overcrowded	
Tadpoles (Frog, toad, salamander)	Ponds	Balanced aquarium	Tropical fish food	Overcrowded	
Crickets	Common in grass and fields	Screened cage or jar. Inch or two of damp sand	Bread, Lettuce, apples, meat scraps, dead insects	Canibalistic	Provide a hiding place, such as a board Will live thru winter
Grass-hoppers	Common everywhere	Screened cage or Meadow terrarium	Leaves Lettuce dipped in water	Parasites Lack of food and moisture	Will die in late fall after mating and laying eggs

Animal	Habitat	Controlled Habitat	Food	Cause of Failure	Remarks
Katydid	On bushes and trees	Same as grasshoppers	Same as grasshoppers		Will die in late fall
Praying Mantis	In tall grass	Screened meadow terrarium	Living insects. Fresh liver	Lack of food	Will eat each other if not provided enough food
Walking Sticks	In trees and bushes	Screened meadow terrarium	Freshly sprouted grass	Lack of food	
Goldfish Minnows		Balanced aquarium, allowing 1 in. of fish to 1 gal. water	Commercial fish food (natural type)	Overcrowding Overfeeding	Remove excess food
Mice and White Rats Hamster Rabbit		Screened cages Wire bottoms with pan underneath	Dry dog food Lettuce Carrots	Drafts Direct sunlight	Plenty of drinking water. Field mice should be kept a day or two for observation and then released. Wild rabbits cannot be kept in captivity
Guinea Pig		Screened cage at 72° temp. Straw on bottom	Dry dog food Lettuce Carrots	Drafts	Cage must be cleaned daily
Snakes	Woods and fields	Screened woodland terrarium	Earthworms Insects Bits of meat Frogs	Sudden change in temp. Lack of drinking water and humidity	Provide hiding space. Like warmth and sun. Skin dull before shedding. Need sticks to rub against when shedding
Snails	Ponds Lakes Streams	Balanced aquarium	Algae Excess fish food. Decaying vegetable matter		
Salamanders Newts Efis	In or near brooks and streams	Semi-aquatic terrarium	Live insects Fruit flies Small earthworms Raw liver		Must have living food or be fed by moving the food offered
Turtles	Ponds	Semi-aquatic	Ant eggs Bits of raw beef Earthworms Mealworms	Too low temperature. Lack of means of getting out of water at will	Must not be put in aquarium. Turtles like company; it is better if there is more than one in container.

Additional References

Pratt, Grace K. HOW TO CARE FOR LIVING THINGS IN THE CLASSROOM. National Science Teachers Association, Washington, D. C. 1965. 35c

PREPARING AND MAINTAINING A FRESH-WATER AQUARIUM

The following steps will assist in developing and maintaining a fresh-water aquarium:

1. Have access to the necessary equipment. This includes a tank, plants (anacharis, caboma, vallisneria), sand, a dip net, fish, snails, and food.
2. Wash the tank thoroughly with soap and water. Rinse it several times to insure cleanliness. Fill the tank and allow it to stand for about a day to provide additional cleansing and to provide a check for leaks.
3. Wash the sand with several rinsings in boiling water. Put about one inch of the clean sand in the bottom of the tank.
4. Lay a large sheet of paper on top of the sand before adding water. This prevents the water from stirring the sand.
5. Add water to within about an inch or two of the top. If tap water is used, allow it to stand for a couple of days to permit the chlorine to escape from the water as a gas.
6. If available, add about two quarts of water from an established aquarium.
7. Add water plants along with water from which they were obtained.
8. Add a few rocks to provide a hiding place for the animals.
9. Provide about two snails for each gallon capacity of the tank.
10. Place in a position of indirect lighting. Avoid direct sunlight.
11. Add fish, using a dip net.
12. Feed regularly. Avoid overfeeding.
13. Add water as needed.
14. Remove excess food, dead animals, and dead plants.

PREPARING AND MAINTAINING A WOODLAND TERRARIUM

A woodland environment can be simulated in the classroom through the following procedures:

1. Locate a suitable, water-proof, glass container for use as a terrarium.
2. Wash the terrarium thoroughly with soap and water. Rinse it several times with clean, clear water.
3. Place about an inch layer of pebbles on the bottom of the terrarium.
4. Place about an inch layer of sand on top of the pebbles.
5. Mix a small amount of charcoal with some woodland soil which contains soil, twigs, and dried leaves. Place about an inch layer of the mixture on top of the sand.
6. Arrange ferns, mosses, lichens, liverworts, wintergreen, and other forest plants in the terrarium, and water thoroughly.
7. Place a snake, frog, newt, or turtle in the container.
8. Cover the container with a screen or plate of glass. If a glass cover is used, fresh air must be permitted to enter at regular intervals to prevent mold.

9. Add water as needed in order to keep the soil moist. However, do not permit the soil to become excessively wet.
10. Provide water and appropriate food for the animal kept in the terrarium.

PREPARING AND MAINTAINING A SEMI-AQUATIC TERRARIUM

A shoreline environment can be simulated in the classroom through the following procedures:

1. Locate a suitable, leakproof, glass container for use as a terrarium.
2. Wash the terrarium thoroughly with soap and water. Rinse it several times with clean, clear water.
3. Prepare a layer of pebbles about an inch deep on the bottom of the container.
4. Using pebbles and sand, build up one end of the interior to about one half the height of the container.
5. Cover the built up area with soil.
6. Plant such things as mosses, ferns, arrowhead, partridge berry, wintergreen berry, lichen, liverworts, and creeping Charlie in the soil on the raised portion.
7. Put water in the shallow end of the container until a pond is created which takes up about half of the terrarium.
8. Place a turtle, salamander, frog, toad, or crayfish in the container.
9. Put a glass cover on the container.
10. Provide water and appropriate food for the animal kept in the terrarium.

PREPARING AND MAINTAINING A DESERT TERRARIUM

A desert environment can be simulated in the classroom through the following procedures:

1. Locate a suitable glass container for use as a terrarium.
2. Wash the terrarium thoroughly with soap and water. Rinse it several times with clean, clear water and dry it.
3. Cover the bottom with four or five inches of fine, dry sand. Use red desert sand if it is available.
4. Plant cacti securely in the sand.
5. Add a desert animal such as a collared lizard or chameleon. Provide piles of rocks in which the animal can hide.
6. Place a small cup of water, about the size of a soft drink bottle cap, in the sand.
7. Cover the container with a screen top.
8. Water thoroughly about every three weeks.
9. Provide water and appropriate food for the animal kept in the terrarium.

COLLECTING INSECTS

In order to develop an insect collection, insects must be caught, killed, and displayed without damage. The following equipment and techniques will prove helpful:

Killing Jar

Some insects can be caught easily and dropped directly into a killing jar.

A killing jar should be a wide-mouth jar. Pour some kerosene or lighter fluid into a wad of cotton and place the cotton in the bottom of the jar. Cut a piece of cardboard the appropriate size to fit down into the jar to hold the cotton in place. Punch several small pinholes through the cardboard and put it into place. Keep the jar closed with a tight-fitting lid.

Insect Net

Some insects move rapidly and therefore are difficult to catch. In order to catch these, it is helpful to have an insect net.

Nets can be made from heavy coat hangers, cheese cloth, and a two to three foot long segment of a broom handle.

Fashion a net hoop out of a coat hanger and attach it securely to a broom handle with wire. Cut out a triangular piece of cheese cloth, two sides of which can then be sewed together to form the triangular-shaped bag of the net. Be certain that the bag is at least six inches longer than the diameter of the hoop so that you can slip the net over when you catch an insect and in this way confine it. Sew the bag to the hoop.

Spreading Board

Winged insects such as moths and butterflies must be specially prepared for display on a spreading board. A spreading board consists of two boards separated by an opening which tapers in width from about one-fourth inch on one end to three-fourths inch on the other, mounted on another board which serves as a base. Place the body of the insect in the opening between the boards and pin it to the base. Position the insect's wings on the board on each side, hold them in place with strips of paper, and use pins in the ends of the paper strips to hold them firm. Precautions should be taken to prevent putting pins through the wings of the insects and damaging them in any way. Drying requires about four or five days under normal conditions.

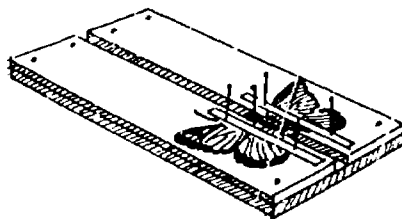

Relaxing Jar

If an insect dries and becomes too hard and brittle to handle, it can be made more pliable in a relaxing jar. Such a jar can be constructed by putting a few inches of sand into a wide-mouth jar and adding water to it. Place a cork or block of wood on top of the sand and put the insect on this support. Close the container tightly and leave the insect inside for a day or two until the insect becomes soft and pliable.

Pinning Insects

Insects are usually displayed on pins with the pin usually inserted through the thorax. Insects too small to be pinned can be glued to the point of a small wedge-shaped piece of paper through which the pin is inserted.

Three labels should be inserted on the pin below the insect. The one immediately below should tell where, when, and by whom it was collected. The second label should indicate the type of environment or the host on which it was collected. The third label should identify the insect.

Storing and Displaying Insects

Dead insects are subject to attack by mice and other insects. They must, therefore, be stored in a box or some other container.

Cigar boxes provide good temporary storage. Put cardboard in the bottom and insert the pins. Wooden boxes with glass tops can be easily made to mount insects for display purposes.

In order to prevent pests from disturbing the collection, keep moth balls or crystals of paradichlorobenzene in storage and display boxes.

Additional Reference

HOW TO MAKE AN INSECT COLLECTION, Word's Natural Science Establishment, Inc., Rochester, New York. 1967. 50¢.

WORKING WITH GLASS TUBING

Glass tubing is a versatile item in the science classroom. However, if not handled carefully, it can produce severe cuts. The following procedures are described to reduce the dangers and help increase the versatility of this common laboratory item:

Cutting Glass Tubing

Glass tubing is usually purchased in long segments. The following steps are provided to assist in cutting pieces to required lengths:

1. Lay the tubing on a flat surface and hold it firmly in place with your hand at the approximate position where the break is to be made.
2. At the position where the cut is desired, produce a deep scratch by drawing the edge of a triangular file firmly across the tube.
3. Use a cloth to cover the tube in the area in which the break is to be made.
4. Grasp the covered tube with both hands so that the scratch is on the outer side, the fingers circle the tube, and the thumbs meet on the opposite side behind the scratch.
5. Snap the tube sharply by pushing outward with the thumbs and, simultaneously, pulling back with the fingers. The tube will break on the scratch mark.

Fire Polishing

The ends of a glass tube have very sharp edges. These edges can be smoothed by fire polishing:

1. Hold the glass tubing so the sharp end is in the top of the flame of a gas burner.
2. Rotate the tube so all sides are heated evenly causing the sharp edges to melt and become smooth.
3. Place the fire-polished tube on an asbestos mat or some other insulating material while it cools.

Bending Glass Tubing

Bending glass tubing is often necessary in order to carry out science experiments. The following procedures are recommended for producing needed configurations:

1. Place a wing top attachment on a gas burner and ignite the burner.
2. Heat the area of the glass tube to be bent while holding it on both sides of the flame.
3. While heating the tube, rotate it constantly in your fingers to insure even heating on all sides.
4. When the glass becomes soft and pliable, remove it from the flame and quickly bend the tube to the desired shape.
5. Place the hot glass on an asbestos mat or some other insulating material while it cools.

Inserting Glass Tubing into Stoppers.

Careless inserting of glass tubing into a stopper may result in breakage and severe cuts. This activity is too dangerous for young children to perform. The following steps are provided to assist the teacher in safely carrying out this procedure:

1. Be certain that the end of the tube to be inserted into the stopper is fire polished.
2. Lubricate the tube and the stopper hole. Glycerine is the most suitable substance for this purpose, but water may be used.
3. Using several layers of cloth to protect both hands while making the actual insertion, grasp the tubing close to the end to be inserted and force it into the stopper hole with a twisting motion.

PREPARING ELECTRICAL CIRCUITS

The way in which the components of an electric circuit are connected is important to the type of experiment which is being performed. The following procedures are prepared to assist in choosing the most appropriate arrangement:

Cells in Series

When connecting cells in series, the positive terminal of one cell is always attached to the negative terminal of another cell. In this type of circuit, voltage is cumulative. Therefore, if $1\frac{1}{2}$ volt cells are used, two cells provide 3 volts, three cells provide $4\frac{1}{2}$ volts, etc.

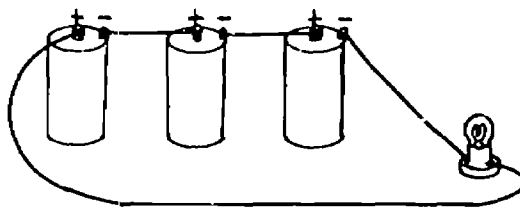

Cells in Parallel

To connect cells in parallel, attach the positive pole of one to the positive pole of an adjoining cell and the negative pole to the negative pole of the

adjoining cell. Regardless of the number of identical cells connected in parallel, the total voltage produced is equal to the voltage of a single cell. The amount of current, however, is increased.

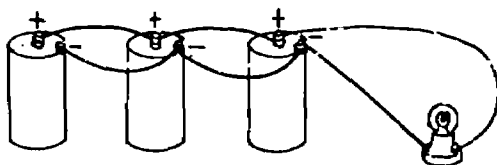

Light Bulbs in Series

Bulbs can be attached in a series circuit to a source of current.

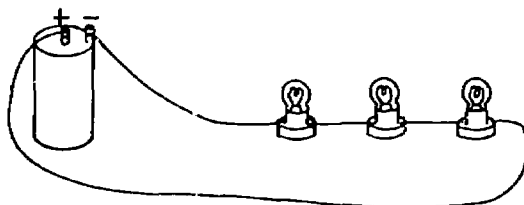

Light Bulbs in Parallel

Bulbs can be attached in a parallel circuit to a source of current.

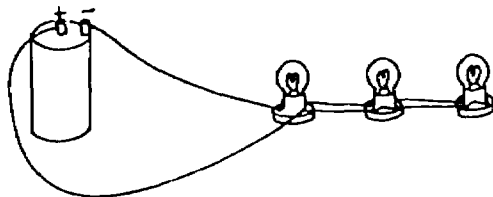

Electric Meters

When making measurements with an electric meter, take care to select a meter which has a range that is broad enough to make the required

measurement. Also, it is essential that the meter be properly connected into the circuit.
A voltmeter should be connected into a circuit in parallel.

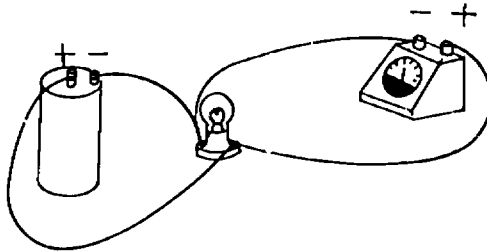

An ammeter should be connected into a circuit in series with a resistance.

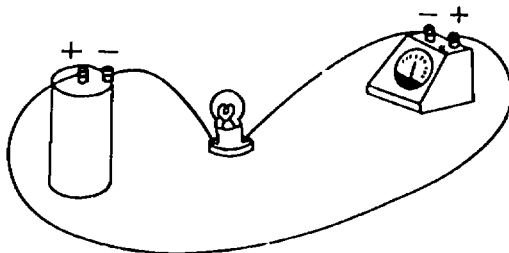

MAKING ACCURATE MEASUREMENTS

Accurate measurements are vital to the study of science. Four factors which commonly contribute to error include parallax, lack of sensitivity, error in judgment, and error in reading.

Parallax

Errors due to parallax result from not aligning the eye directly with the scale of the instrument which is being used in a measurement. For example, if a thick ruler is placed on a block of wood and moved up and down before the eye, it can be seen that the angle at which the ruler and the top of the block are viewed determines the reading which is made. Care must be taken to view the scale from a position directly opposite the top of the wooden block. The same principle is true in the reading of many other types of scales and meters.

Lack of Sensitivity

It is obvious that an ordinary ruler is useless in measuring the thickness of a sheet of paper and a spring balance cannot be used to weigh a human hair. So, a ruler which is marked only in inches lacks graduations for measuring an object to the nearest sixteenth of an inch. In order to gain accuracy, the measuring instrument must be chosen which is graduated to the sensitivity desired in the measurement.

Error in Judgment

It is customary to estimate measurements beyond the sensitivity of the instrument employed. For example, if a ruler is being used which is marked in eighths of an inch and the object being measured extends between the markings, the reader may attempt to estimate the reading in thirty-secondths of an inch. Accuracy is dependent upon the individual's skill in making such a judgment. Practice is valuable in increasing accuracy.

Error in Reading

Lack of care can result in reading the wrong number from a measurement scale. Measurements should be carefully read and checked for accuracy.

SOURCES OF ASSISTANCE

The following references are recommended as sources of assistance in carrying out an effective elementary school science program:

- Hone, E. B., A. Joseph, E. Victor, and P. Brandwein. *A SOURCEBOOK FOR ELEMENTARY SCIENCE*. Harcourt, Brace & World, Inc., New York. 1962.
- Joseph, A., P. Brandwein, E. Morholt, H. Pollock, J. Costka. *A SOURCEBOOK FOR THE PHYSICAL SCIENCES*. Harcourt, Brace & World, Inc., New York. 1961.
- Morholt, E., P. Brandwein, A. Joseph. *A SOURCEBOOK FOR THE BIOLOGICAL SCIENCES*. Harcourt, Brace & World, Inc., New York. 1958.
- UNESCO. *700 SCIENCE EXPERIMENTS FOR EVERYONE*. Doubleday & Company, Inc., Garden City, New York. 1958.
- Victor, Edward. *SCIENCE FOR THE ELEMENTARY SCHOOL*. Macmillan Company, New York. 1965.

APPENDIX B

Safety in Science Teaching

Because good science instruction involves the use of a wide variety of equipment and materials, the risk of accidents and injury is always present. It is urged that all teachers be aware of precautions which can be taken to reduce this risk.

The following guidelines for safety in science teaching are from "Children Learn Science, A Guide for Elementary School Teachers," prepared by the Public Schools of Hammond, Indiana, by Gerald S. Spitzer, Coordinator of Science and Health, and are being used with the permission of the Hammond Public Schools.

SAFETY IN SCIENCE

All children must develop sensible attitudes in relation to taking safety precautions in working in science. Attitudes determine behavior and cannot be taught as abstractions. Children's safety attitudes are built from experiences they have. The school has a responsibility to teach safety. Safety attitudes and behaviors should be taught through situations that fall within the range of a child's own experience. Simple explanations of what not to do must be reinforced with reasons that children can understand. Science requires active participation, and thus the teaching of safety practices is essential. The best guide to safety in science is the use of good common sense by children and teachers.

General Safety Practices

1. If there is a question about hazards in working with the materials and equipment of science, the watchword to use is "DON'T."
2. A teacher should work through the handling of equipment and materials, find out about all possible hazards, and be sure that the experience is a reasonably safe one before proceeding.
3. Teachers should practice general safety procedures in relation to the use of fire and instruct children in how to take appropriate precautions. Teachers should consult with the principal regarding fire regulations.
4. At the beginning of any experience, if there is any special hazard, children should be specifically instructed regarding the recognition of dangers and the precautions to be taken. This particularly includes experimentation and study trips.
5. If children are working in groups with limited amounts of equipment, each group should be small enough to prevent confusion which might result in accidents.
6. When using equipment that might present special hazards, individual and group work should be arranged in the classroom so there can be constant teacher supervision.
7. All accidents resulting from the handling of equipment should be reported to the teacher.
8. Children should never carry equipment through the halls when classes are passing.
9. Children should be allowed sufficient time to perform experiments, because haste sometimes causes accidents.
10. A child should not perform any experiments, at school or at home, without thorough investigation by the teacher before a child proceeds.
11. Any piece of equipment that has been heated (microprojector, hot plates, A.V. devices) should not be moved until it has cooled.

12. Hazardous materials and equipment not in use should be labeled "KEEP HANDS OFF."
13. Before permitting children to work with sharp tools, the teacher must be assured that children are competent to use these tools.
14. It is to be remembered that there is always danger when heating a liquid which is confined in a container.
15. Glass wool and steel wool should be handled with gloves.

Safety in Relation to Animals and Plants

1. All mammals used in a classroom should be inoculated for rabies, unless purchased from a reliable scientific company.
2. The following animals should never be brought into the classroom: wild rabbits, snapping turtles, poisonous snakes, or insects that may be disease carriers. Children should not bring their pets to the classroom unless the activity is carefully planned by the teacher.
3. Before a small animal is brought into the classroom for observation, plans should be made for proper habitat and food. The living quarters of animals in the classroom must be kept clean, free from contamination, and secure enough to confine the animals. Plans should be made for care of the animals over the weekends and during vacation periods.
4. Animals should be handled only if it is necessary. This handling should be done properly according to the particular animal. Special handling is required if the animal is excited, is feeding, is pregnant, or is with its young.
5. Children should wash their hands after handling turtles, snakes, fish, frogs, toads, etc. Also, the water from the habitat should be disposed of carefully.
6. Children should be cautioned never to tease the animals or to insert their fingers or objects through wire mesh cages.
7. Any child who is bitten or scratched by an animal should report immediately to the school nurse.
8. After a period of animal observation is completed, animals should be returned to their natural environment.
9. Before taking study trips into wooded areas, identify and discuss plants which produce poisonous effects.
10. The use of flowers and mold which have excessive spores should be used with caution because of possible allergies of children.
11. There is great danger of contamination from bacteria cultures unless sterile techniques are used.

Safety with Chemicals

1. Label all bottles so that their contents may be identified.
2. Pupils should never test unknown chemicals by taste or touch.
3. Chemicals should never be mixed just to see what will happen.
4. If volatile or flammable liquids are used in a demonstration, extreme care should be taken to insure that hot plates or open flames are at safe distances from the fumes.
5. Rosin, shellac, alcohols, charcoal, etc., should be stored in glass-stoppered bottles or in bottles with plastic tops.

6. Combustible materials should be kept in a metal cabinet equipped with a lock.
7. Chemicals should be stored in a cool place but should not be stored in a refrigerator.
8. Children should never experiment with rocket fuel propulsion devices.
9. Volatile substances which are spilled should be disposed of in fire-proof receptacles.
10. The use of such preservatives as formaldehyde and alcohol demands protection for the skin. Preserved specimens should be washed in clean water and kept in salt water for use during the day. To remove specimens from preservatives, use tongs and rubber gloves.

Safety with Electricity

1. At the beginning of the study of a unit on electricity, children should be told not to experiment with the electric current of home and school circuits.
2. Children need to be taught safety precautions regarding the use of electricity in everyday situations.
3. Children should never handle electric devices immediately after their use because these devices might retain a high temperature for a period of time.
4. To remove an electric plug from a socket, pull the plug and not the cord.
5. It is to be recognized that short-circuited dry cells can produce a high temperature which can cause a serious burn.
6. Storage batteries are dangerous because of the acids that they contain and the possibility of short circuits within them.

Safety with Glassware

1. Glassware which is to be heated should be only Pyrex or a similarly heat-treated glassware.
2. All glass tubing used with corks or stoppers should be polished or have the edges beveled with emery paper.
3. A soap solution or glycerine should be used on the top of glass rods or tubing for lubrication before inserting them into a cork or stopper. Tubing should be wrapped with several layers of cloth or in a rubber tubing holder. The tubing should be held as close to the cork as possible.
4. Corks should be removed from tubing to keep them from adhering and "freezing." "Frozen" stoppers can be removed by splitting them with a razor blade and then reclosing them with rubber glue.
5. Broken glassware should be disposed of in a special container marked "BROKEN GLASS."
6. The fingers should never be used to pick up broken glass. A whisk broom and dustpan can be used for large pieces, and large pieces of wet cotton can be used for very small pieces.
7. Glassware should be thoroughly cleaned after use.
8. Children should never drink from glassware that has been used for science experimentation.
9. Sharp edges on mirrors or glassware should be reported to the teacher.
10. Glass objects which might break should be wrapped with plastic wrap or wire screening.

APPENDIX C

Equipment for Science Instruction

The following list includes all equipment and materials required to perform the experiments and activities described in this bulletin. Space is provided for developing an inventory of equipment by writing in the quantity of each item available in your school.

A	_____ Bulb, light, 1½ volt	_____ Curtain rod, brass
_____ Alcohol	_____ Bulbs, plant	
_____ Algae	_____ Bulletin board	D
_____ Almanac	_____ Burner, alcohol	_____ Dishes
_____ Alum		_____ Dish, glass baking
_____ Aluminum foil	C	_____ Doll
_____ Ammonia, household	_____ Cactus	_____ Doll clothes
_____ Ammonium bichromate	_____ Cages, animal	_____ Doll, rag
_____ Animal crackers	_____ Calendars	_____ Dominoes
_____ Animal organs and parts	_____ Camera and film	_____ Doorbell
_____ Animal products	_____ Cans	_____ Dry cells, 1½ volt
_____ Animals	_____ Candles	_____ Dry cells, flashlight
_____ Antiseptics	_____ Carbonated soft drink	
_____ Ant nest, observation	_____ Cardboard	E
_____ Ants	_____ Cards (3" x 5")	_____ Ear model
_____ Apples	_____ Carrots	_____ Earthworms
_____ Aquarium	_____ Celery	_____ Eggs
_____ Atomic submarine model	_____ Cellophane, colored	_____ Electromagnetic wave spectrum chart
	_____ Cement	_____ Elements, examples
B	_____ Chairs	_____ Elodea
_____ Baking pans	_____ Chalk	_____ Envelopes
_____ Baking soda	_____ Chalkboard	_____ Erasers
_____ Balance	_____ Chemistry set	_____ Erector set
_____ Ball	_____ Chicken backbones	_____ Erlenmeyer flask
_____ Balloons	_____ Chicken, broiler	_____ Eye, cow
_____ Banana	_____ Clay (variety of colors)	_____ Eyedropper
_____ Barometer	_____ Clock, luminous dial	
_____ Basketball	_____ Clock which ticks	F
_____ Bean seeds	_____ Cloth	_____ Fan, electric
_____ Binoculars	_____ Clothesline (25')	_____ Ferns
_____ Bimetallic strip	_____ Cobalt chloride	_____ Filter paper
_____ Bird feeder	_____ Coins	_____ Fish
_____ Bird nests	_____ Comb	_____ Flashlight
_____ Blindfold	_____ Compass	_____ Flashlight bulb
_____ Blotter paper	_____ Convection box	_____ Flower pot
_____ Boards, wooden	_____ Copper strips	_____ Flour
_____ Bolt and washer	_____ Copper sulfate	_____ Food coloring
_____ Books	_____ Corks	_____ Food packages
_____ Bottles	_____ Cotton	_____ Foot, chicken
_____ Bowl	_____ Crayons	_____ Fossils
_____ Boxes	_____ Cream (dairy)	_____ Fruit flies
_____ Bread	_____ Cup	
_____ Bricks		

..... Fruits	K Mushroom
..... Frying pan Knife Musical instruments
..... Fuels Knitting needle	N
..... Fungi	L Nails
..... Funnels Ladder Newspapers
..... Fuses Lamp Notebook
G Lamp chimney	O
..... Galvanometer Lead fishing sinkers Onion
..... Geranium Leaves Optical instruments
..... Glass Lemon Overhead projector
..... Glass, drinking Lettuce	P
..... Glass, frosted Light meter Paints
..... Glass tube, 3/4" diameter Limestone Paint brushes
..... Glass tubing Limewater Pens
..... Globe Litmus paper (blue and red) Pan, Pyrex and lid
..... Glue Loam Paper (variety of colors)
..... Glycerine Lodestone Paper bags
..... Goldfish	M Paper clips
..... Gravel Magazines Paper-mache
..... Guppies Magnets, bar Paper towels
II Magnets, horseshoe Paraffin
..... Hailstones Magnesium Paste
..... Hammer Magnesium powder Percils
..... Hammer, rubber Magnifying glass Penny
..... Hamster Maps Periodic chart of elements
..... Handbook of Chemistry and Physics Marble Phonograph
..... Handkerchief Marble chips Phonograph record
..... Hand lens Marbles Piano
..... Hard rubber rod Masking tape Pictures of animals
..... Health records Matches, large, wooden Pictures of animal products
..... Hoe Measuring cup Pictures of astronauts
..... Horoscope Medicine vial Pictures of extinct animals
..... Hose, water Metal rod Pins
..... Hot plate, electric Metal weight Ping-Pong balls
J Mice Ping-Pong ball gun
..... Ice Microscope Pitcher
..... Incubator Microscope slides Pitch balls
..... Ink Milk Plants
..... Insects Milk bottles Plaster of Paris
..... Iron filings Milk cartons Plastic
J Minerals Plastic toothbrush container
..... Jars Mirrors (plain, concave, convex) Plastic wrap
 Mosses Plates, dinner
 Motor, electric	

-----	Pliers	-----	Shale	-----	Test tube rack
-----	Plumber's plunger	-----	Sheet	-----	Thermometers (Celsius and Fahrenheit)
-----	Plywood	-----	Shovel	-----	Thermostat
-----	Potassium iodide	-----	Silk	-----	Thread
-----	Potassium permanganate	-----	Sink	-----	Thumbtack
-----	Potato	-----	Skateboard	-----	Tincture of iodine
-----	Potato starch	-----	Slate	-----	Tinsel, metallic
-----	Poster paper	-----	Slide projector	-----	Tinker toys
-----	Pound weight	-----	Slinky	-----	Tissue paper
-----	Prism	-----	Snake plant	-----	Toad stools
-----	Protractor	-----	Snow	-----	Tongs
-----	Puffed rice	-----	Socket, miniature, light	-----	Tools
-----	Pulleys	-----	Sod	-----	Toothpick
-----	Pump, air	-----	Soil	-----	Towels, paper
-----	Punk stick	-----	Spool	-----	Toy animals
-----	Pussy willow twig	-----	Spoon	-----	Toy blocks
		-----	Spotlight	-----	Toy block wagon
R		-----	Spring balance	-----	Tripod, camera
-----	Rain gauge	-----	Sprinkling can	-----	Tub, laundry
-----	Rake	-----	Stamps	-----	Tubes, cardboard
-----	Razor blades	-----	Stapler	-----	Tuning forks, mounted with rider
-----	Reference books	-----	Star chart	-----	Tweezers
-----	Refrigerator	-----	Steel wool		
-----	Relative humidity chart	-----	Stethoscope	U	
-----	Ring stand and rings	-----	Stones	-----	Umbrella, black
-----	Rocks	-----	Stopper, sink, large		
-----	Roller skates	-----	Stoppers, rubber	V	
-----	Rope	-----	Straw, soda	-----	Vaseline
-----	Rubber ball	-----	String	-----	Vinegar
-----	Rubber cement	-----	Sugar	-----	Volley ball
-----	Rubber tubing	-----	Sulfur		
-----	Rubbing alcohol	-----	Supports	W	
-----	Ruler with arched groove	-----	Sweet potato	-----	Wagon, toy
		-----	Switches, electric	-----	Washers
S		-----	Switch, push button	-----	Water
-----	Salad oil			-----	Water pistol
-----	Salt	T		-----	Water plants
-----	Sand	-----	Table	-----	Water snails
-----	Sandbox	-----	Tablespoon	-----	Wax paper
-----	Sandpaper	-----	Tacks	-----	Weather maps
-----	Sandstone	-----	Tagboard	-----	Weights
-----	Scalpel	-----	Tape	-----	Wet and dry bulb thermometer
-----	Science journals	-----	Teaspoons	-----	Wheel and axle
-----	Scissors	-----	Telescope	-----	Window shades
-----	Screen, projection	-----	Tempera paints	-----	Wire
-----	Screen, wire	-----	Tennis ball	-----	Wire, copper
-----	Seed catalog	-----	Terrariums		
-----	Seeds (lettuce, lima beans, rye, etc.)	-----	Test tubes		
		-----	Test tube holder		

_____ Wire, nickel	_____ Wood	_____ Wool cloth
_____ Wire, insulated	_____ Wood blocks	_____ Y
_____ Wires, variety of metals	_____ Wood splints	_____ Yardstick
_____ Wire gauze	_____ Wooden stakes	_____ Yeast

General Listing of Equipment for Elementary School Science Instruction

To assist schools in accumulating equipment appropriate for a broad science instructional program, the following provides a basic, standard, and advanced list for elementary science. Space is provided for developing an inventory of equipment by writing in the quantity of each item available in your school.

(Piltz, Albert. SCIENCE EQUIPMENT AND MATERIALS FOR ELEMENTARY SCHOOLS. U. S. Department of Health, Education, and Welfare, 1961, pages 51-54.)

ELEMENTARY SCIENCE: BASIC

<ul style="list-style-type: none"> _____ Anemometer _____ Balance, Spring, Heavy Duty _____ Barometer, Aneroid _____ Beaker, Griffin, Low Form _____ Bell, Electric _____ Pinocular, 4x _____ Boiler, Double _____ Buzzer, Electric _____ Clamps and Tongs _____ Compass, Magnetic, 1.5 cm. _____ Compass, Magnetic, 4.5 cm. _____ Electromagnet, Horseshoe Form _____ First-aid Cabinet, with Supplies _____ Flashlight-Cell Holder _____ Flask, Erlenmeyer _____ Flask, Florence, Flat Bottom _____ Globe, Terrestrial _____ Hot Plate, Electric, Three-Heat, Single Unit _____ Hot Plate, Single Unit _____ Kits _____ Lamp, Electric, Miniature _____ Lenses, Demonstration Set _____ Magnet, Bar 	<ul style="list-style-type: none"> _____ Magnet, Bar Alnico _____ Magnet, Horseshoe _____ Magnet, Horseshoe, Alnico _____ Magnet, U-Shaped _____ Magnifier, Reading Glass _____ Meter Sticks _____ Microscope, Elementary _____ Net, Insect, Collapsible _____ Prism, Equilateral _____ Prism, Equilateral, Lucite _____ Receptacles for Miniature Electric Lamps _____ Rod, Glass _____ Spatula, Stainless Steel _____ Test Tubes, Borosilicate _____ Thermometer, Celsius, Fahrenheit, Combined Scale _____ Thermometer, Celsius, -10° to $+110^{\circ}$ _____ Thermometer, Large, Wall _____ Tools _____ Tubing, Glass _____ Tubing, Rubber and Plastic _____ Test Meter _____ Volt-Ammeter, Battery
--	--

ELEMENTARY SCIENCE: STANDARD

<ul style="list-style-type: none"> _____ Anemometer, Portable _____ Ant Nest, Observation _____ Aquarium _____ Aquarium Aerator _____ Atoms and Molecules, Magnetic _____ Balance, Fulcrum _____ Balance, Spring _____ Balance, Spring, Dial Scale _____ Ball and Ring _____ Barometer, Aneroid _____ Barometer, Mercury _____ Barometer, Mercury, Demonstration _____ Block, Cubic Foot, Dissectible _____ Board, Spreading, Insect _____ Cage, Animal _____ Cage, Animal, Collapsible _____ Cage, Insect _____ Camera, 35 mm. 	<ul style="list-style-type: none"> _____ Case, Insect Specimen, Storage _____ Collection, Rock and Mineral Demonstration _____ Convection Apparatus _____ Copying Machine, Transparency Maker _____ Cork Borers, Hand _____ Dish, Evaporating, Porcelain _____ Dish, Laboratory, Plastic _____ Dish, Large Borosilicate _____ Electromagnet, Ironclad, Lifting _____ Filters, Light, Plastic Set _____ Forceps, Straight _____ Funnels, Filtering, 60° Polyethylene _____ Funnel, Tube, Thistle Top _____ Germinating Box _____ Globe _____ Globe, Celestial
---	--

- | | | | |
|-------|---|-------|--|
| ----- | Globe, Hall Tellurian | ----- | Projector, Overhead |
| ----- | Gyroscope, Simple Form | ----- | Projector, 16 mm., Motion Picture, Sound |
| ----- | Hygrometer, Wet and Dry Bulb | ----- | Projector, Motion Picture, Sound |
| ----- | Hygrometer, Wet and Dry Bulb with Tables | ----- | Projector, Slide, 3¼" x 4" |
| ----- | Illuminator, Incandescent Projection Bulb | ----- | Projector Stand |
| ----- | Incubator, Egg | ----- | Pulley |
| ----- | Jar, Battery, Cylindrical | ----- | Psychrometer, Sling |
| ----- | Kits | ----- | Radiometer |
| ----- | Lamp, Alcohol | ----- | Rain Gauge |
| ----- | Lamp Chimney | ----- | Receiver, Telephone |
| ----- | Liter Block, Dissectible | ----- | Ruler, English and Metric Scales |
| ----- | Magnet, Bar, Cylindrical Alnico | ----- | Slide, Cover Glass, Microscope |
| ----- | Magnet, Electromagnet, Lifting Type | ----- | Slides, Microscope, Plain |
| ----- | Magnet, Wobbly Bar | ----- | Steam Engine, Electrically Heated |
| ----- | Magnifier, Coddington | ----- | Support Stand, Metal, Ring Stand |
| ----- | Magnifier, Dissecting | ----- | Support Stand, Wooden |
| ----- | Magnifiers, Pocket, Folding | ----- | Support, Test Tube |
| ----- | Map, Slated or Blackboard | ----- | Support, Test Tube, Polyethylene |
| ----- | Map, U.S., Relief, Large | ----- | Tape, Measuring, Metric and English |
| ----- | Mat, Asbestos | ----- | Telegraph Set |
| ----- | Measures, Liquid, Metric | ----- | Terrarium |
| ----- | Microprojector with Two Objectives | ----- | Thermometer, Alcohol Filled |
| ----- | Microscope, Elementary | ----- | Thermometer, Clinical, Oral |
| ----- | Mirror, Plane | ----- | Thermometer, Dial Type |
| ----- | Model, Gas Engine | ----- | Thermometer, Outdoor |
| ----- | Model, Steam Engine, Locomotive Design | ----- | Thermometer, Outdoor Weather |
| ----- | Model, Water Wheel | ----- | Timer, Interval, Spring Wound |
| ----- | Models, Dinosaur | ----- | Timer, Stop Watch |
| ----- | Motor, Battery Operated | ----- | Top, Color |
| ----- | Motor, Electric, St. Louis | ----- | Transformer, Small |
| ----- | Needle, Magnetic, Mounted | ----- | Transmitter, Telephone |
| ----- | Net, Towing | ----- | Trough, Pneumatic |
| ----- | Organ Pipe | ----- | Tuning Forks, Set |
| ----- | Pins, Insect | ----- | Vivarium |
| ----- | Planetarium, Trippensee, Hand Driven | ----- | Wagon, Laboratory |
| ----- | Power Supply, Electric, Low Voltage | ----- | Wagon, Laboratory, Stainless Steel |
| ----- | Projection Screen | ----- | Weights, Brass, English Units |
| ----- | Projector, Filmstrip and Slide | ----- | Weights, Iron, English Units |
| ----- | Projector, Opaque | ----- | Weights, Slotted, Metric, Small |
| | | ----- | Xylophone, Eight Bars |

ELEMENTARY SCIENCE: ADVANCED

- | | | | |
|-------|--|-------|--|
| ----- | Altimeter, Auto Type | ----- | Camera, Motion Picture, 8mm. |
| ----- | Anemometer, Weather Instrument Type | ----- | Camera, Motion Picture, 16mm. |
| ----- | Aquarium, Heater and Thermostat | ----- | Cell, Student Demonstration |
| ----- | Autoclave, Steam Pressure | ----- | Center of Gravity Apparatus |
| ----- | Balance, Single Beam, Avoirdupois and Metric | ----- | Center of Gravity Apparatus, Rotator Accessory |
| ----- | Balance, Triple Beam, Low Form, Heavy Duty | ----- | Center of Gravity Apparatus, Set |
| ----- | Bar, Compound | ----- | Chart, the Elements |
| ----- | Bee Hive, Observation | ----- | Chart, Periodic, Long Form |
| ----- | Binocular, Wide Field | ----- | Charts, Geology and Astronomy |
| ----- | Board, Dissecting, Animal | ----- | Charts, Life History and Habitat |
| ----- | Bottle, Vacuum | ----- | Cloud Apparatus |
| ----- | Burner, Bunsen | ----- | Collection, Fossil |
| ----- | Burner, Propane, Disposable Cylinder | ----- | Collection, Rock and Mineral, Study |
| ----- | Camera, Pinhole | ----- | Color Disks with Motor |

- Conductometer for Heat
- Convection Apparatus, Liquids
- Cylinder, Graduated
- Density Cylinder
- Dissecting, Set, Student
- Earphones
- Electrical Circuit, Basic, Kit
- Electrolysis Apparatus, Hoffman
- Electroscope, Flask Form
- Filters, Light, Set
- Flower Press
- Fluorescent Minerals Kit
- Globe, Magnetic
- Gyroscope with Counterpoise
- Gyroscope with Gimbal Rings
- Jar, Bell, High, Solid Top
- Kits
- "Light-Pipe," Rod
- Magna-Poster of Earth and Moon
- Magna-Poster of Planets
- Magnet, Model
- Magnet, Floating
- Magnetic Needle, Dipping
- Magnetizer
- Map, U. S., Relief, Puzzle
- Microprojector with Three Objectives
- Model, Airplane
- Model, Ear, Separable
- Model, Eye, Separable
- Model, Flower
- Model, Force Pump
- Model, Gasoline and Diesel Engine
- Model, Human Skeleton
- Model, Leaf
- Model, Lift Pump
- Model, Lurg Demonstration
- Model, Stem, Dicotyledon
- Model, Stem, Monocotyledon
- Motor Assembly Kit
- Mounts, Riker
- Organ Pipes, Set
- Orrery, Shadow (Planetarium)
- Pulse Glass, Large Form
- Pump, Air, Large Size
- Pump, Air, Small Size
- Pump, with Pump Plate, Hand Driven
- Rod, Permalloy
- Rotator, Hand Driven
- Simple Machines, Demonstration
- Soil Test Set
- Sundial
- Telescope, Three-inch, Refracting
- Thermometer, Maximum-Minimum
- Thermometer, Soil
- Timer, Clock, Electric, Stop
- Tube, Barometer
- Vasculum
- Whistle, Galton's

APPENDIX D

Illustrations of Commonly Used Science Equipment

The following diagrams are provided in order to assist in the identification of pieces of equipment which are frequently referred to and used in a science instructional program.

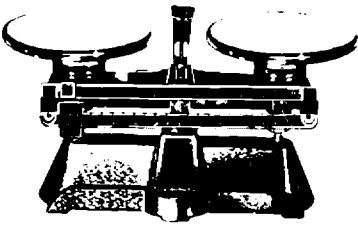

Balance



Balance, Spring

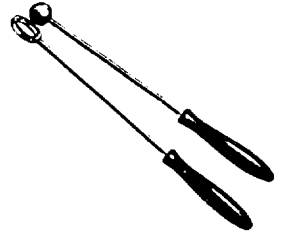

Ball and Ring

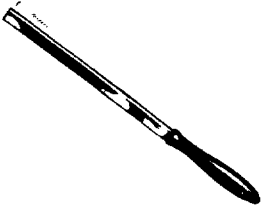

Expansion Bar (Bimetallic)

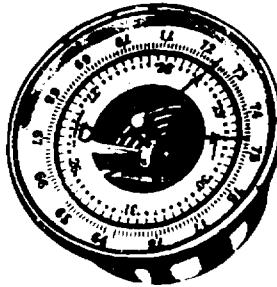

Aneroid Barometer



Battery, 1 1/2 Volt



Beaker



Bell, Electric

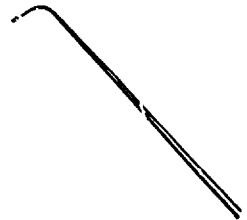

Blowpipe



Wide-Mouth Bottle

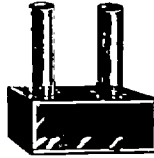

Convection Box



Push Button

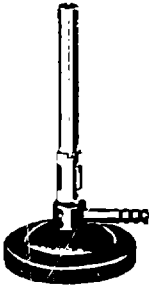

Burner, Bunsen

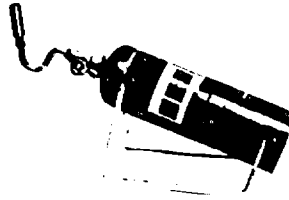

Burner, Propane Gas



Buzzer, Electric

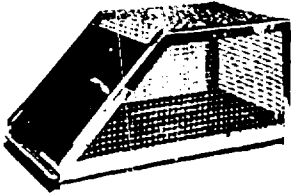

Animal Cage



Micrometer Caliper



Dry Cell

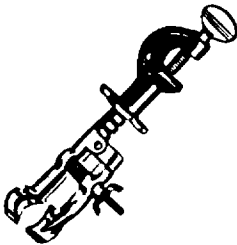

Burette Clamp

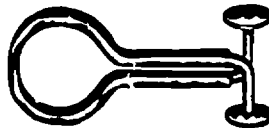

Tubing Clamp

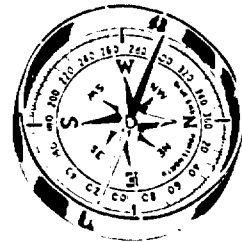

Compass



Glass Cutter

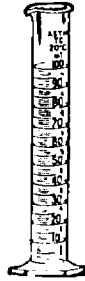

Graduated Cylinder

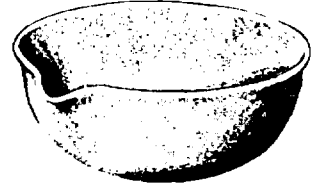

Evaporating Dish



Electroscope



Boiling Flask



Erlenmeyer Flask

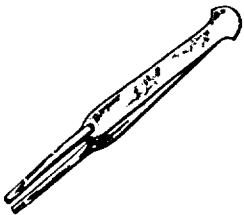

Forceps

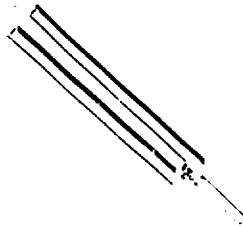

Tuning Fork

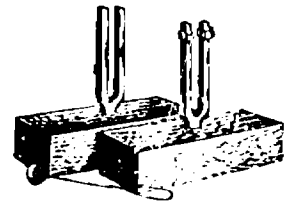

Sympathetic Tuning Forks

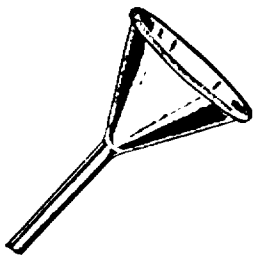

Funnel

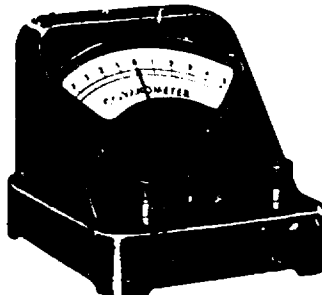

Galvanometer



Watch Glass

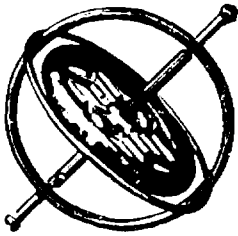

Gyroscope

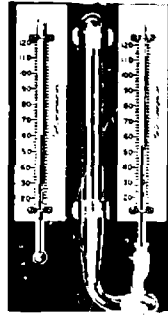

Hygrometer, Wet-and-Dry-Bulb



Battery Jar

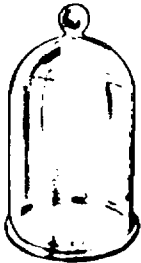

Bell Jar



Alcohol Lamp

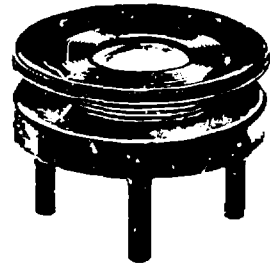

Magnifier

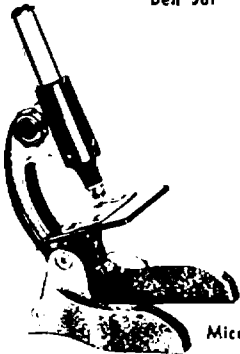

Microscope



Mortar and Pestle

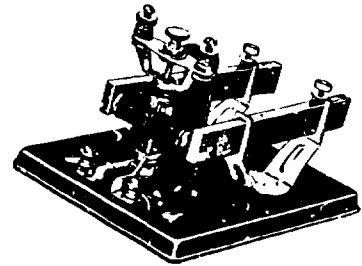

St. Louis Motor



Ant Nest

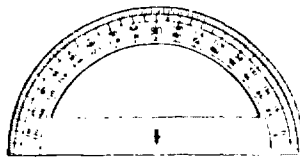

Protractor

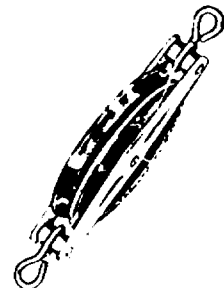

Pulley

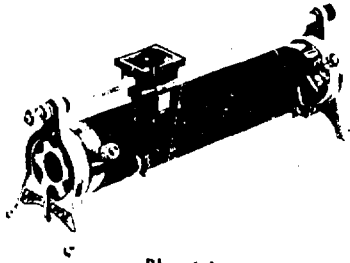

Rheostat

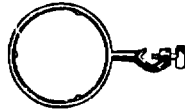

Ring



Ring Stand

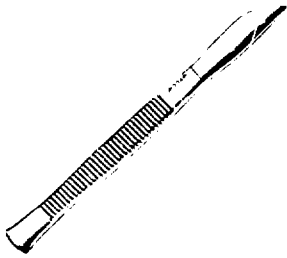

Scalpel

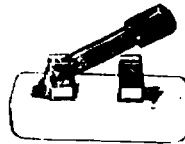

Switch, Knife

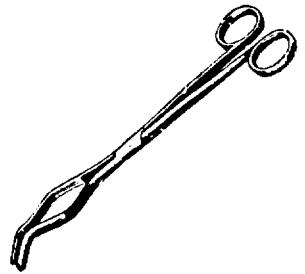

Tongs



Test Tube

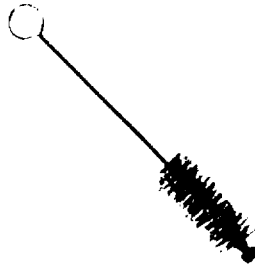

Test Tube Brush

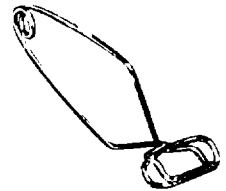

Test Tube Clamp

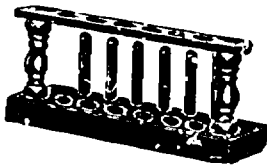

Test Tube Support



Thistle Tube

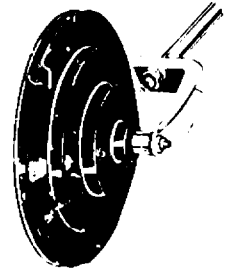

Wheel and Axle

APPENDIX E

Evaluation of Elementary School Science Instruction

Having established a science instructional program for use in your school and classroom, a periodic effort should be made to evaluate the teaching procedures which are being used. Such an evaluation should take into account the objectives and philosophy of science teaching which have been adopted for your program. Additional criteria for this evaluation are provided below.

TEACHER'S CHECKLIST IN ELEMENTARY SCIENCE

Purpose: To measure the effectiveness of school practices and procedures in teaching science in the elementary school.

I. In my teaching is there opportunity or provision for children to:

	None	Some	Much		None	Some	Much
(a) Raise questions and problems of importance or interest to them?	-----	-----	-----	Through experimenting?	-----	-----	-----
(b) Study these questions and problems?	-----	-----	-----	Through talking to resource persons?	-----	-----	-----
(c) Help plan "things to do" in studying science problems?	-----	-----	-----	(g) Analyze the data (information) to see how it relates to the problem?	-----	-----	-----
(d) State clearly the problems on which they are working?	-----	-----	-----	(h) Think about the applications of their science learnings to everyday living?	-----	-----	-----
(e) Make hypotheses to be tested?	-----	-----	-----	(i) Think about science relationships and processes instead of merely naming things and learning isolated facts?	-----	-----	-----
(f) Gather accurate data (information) in a variety of ways: Through making careful observations?	-----	-----	-----	(j) Bring science materials of different kinds to school for observation and study?	-----	-----	-----
Through reading on the subject?	-----	-----	-----	(k) Engage in individual science interests?	-----	-----	-----
Through taking field trips?	-----	-----	-----				
Through watching demonstrations?	-----	-----	-----				

II. In my teaching do I periodically and systematically check on the children's growth in:

	None	Some	Much		None	Some	Much
(a) Ability to locate and define problems around them?	-----	-----	-----	(h) Ability to distinguish between facts and fancies?	-----	-----	-----
(b) Acquiring information on the problem being studied?	-----	-----	-----	(i) Suspending judgment until evidence is collected?	-----	-----	-----
(c) Ability to observe more accurately?	-----	-----	-----	(j) Being open-minded and willing to change one's ideas?	-----	-----	-----
(d) Ability to make reports on or record their observations?	-----	-----	-----	(k) Cooperating with others?	-----	-----	-----
(e) Ability to solve problems?	-----	-----	-----	(l) Understanding cause and effect of relationships?	-----	-----	-----
(f) Ability to think critically?	-----	-----	-----	(m) Skill in using more common scientific instruments (thermometers, scales, rulers, etc.)?	-----	-----	-----
(g) Ability to explain natural phenomena?	-----	-----	-----				

Source: "Evaluating Teaching Practices in Elementary Science,"
Education Bulletin, No. 21 July 1959. (OE-20009-21)
Washington, D. C.: Department of Health, Education,
and Welfare, Office of Education

APPENDIX F

Professional References in Elementary School Science Education

The following references contain information which is helpful in planning and implementing an elementary school science program.

- Association for Childhood Education International. **YOUNG CHILDREN AND SCIENCE**. Washington, D. C., 1964. 56 pp.
- Aylesworth, Thomas G. **PLANNING FOR EFFECTIVE SCIENCE TEACHING**. Middletown, Conn.: Department of School Services and Publications, Wesleyan University, 1963. 96 pp.
- Blough, Glenn O., and Julius Schwartz. **ELEMENTARY SCHOOL SCIENCE AND HOW TO TEACH IT**. New York: Holt, Rinehart and Winston, 1964.
- Craig, Gerald S. **SCIENCE FOR THE ELEMENTARY SCHOOL TEACHER**. Boston: Ginn and Company, 1958. 894 pp.
- Educational Policies Commission. **THE SPIRIT OF SCIENCE**. Washington, D. C.: National Education Association, 1966.
- Hedges, William D. **TESTING AND EVALUATION FOR THE SCIENCES**. Belmont, Calif.: Wadsworth, 1966. 248 pp. \$3.65.
- Hennessy, David E. **ELEMENTARY TEACHERS CLASSROOM SCIENCE DEMONSTRATIONS AND ACTIVITIES**. Englewood Cliffs, N. J.: Prentice-Hall, 1964. 308 pp.
- Hone, Elizabeth, et al. **TEACHING ELEMENTARY SCIENCE: A SOURCEBOOK FOR ELEMENTARY SCIENCE**. New York: Harcourt, Brace and World, 1962. 552 pp.
- Kambly, Paul, and John E. Suttle. **TEACHING ELEMENTARY SCHOOL SCIENCE**. New York: The Ronald Press Co., 1963. 492 pp.
- Lewis, June, and Irene C. Patter. **THE TEACHING OF SCIENCE IN THE ELEMENTARY SCHOOL**. Englewood Cliffs, N. J.: Prentice-Hall, Inc., 1961. 381 pp.
- National Science Teachers Association. **INVESTIGATING SCIENCE WITH CHILDREN**. 6 Vols. Washington, D. C., 1964.
- National Science Teachers Association. **NEW DEVELOPMENTS IN ELEMENTARY SCHOOL SCIENCE**. Washington, D. C., 1963. 56 pp. \$1.50.
- National Science Teachers Association. **THEORY INTO ACTION IN SCIENCE CURRICULUM DEVELOPMENT**. Washington, D. C., 1964. 40 pp. \$1.50.
- National Society for the Study of Education. **A PROGRAM FOR TEACHING SCIENCE**. Thirty-first Yearbook, Part I. Chicago: University of Chicago Press, 1947. 300 pp.
- National Society for the Study of Education. **RETHINKING SCIENCE EDUCATION**. Fifty-ninth Yearbook, Part I. Chicago: University of Chicago Press, 1960. 314 pp.
- Navarra, John Gabriel, and Joseph ZaKoroni. **SCIENCE TODAY FOR THE ELEMENTARY SCHOOL TEACHER**. New York: Harper and Row, 1960. 470 pp.
- Tannenbaum, Harold E., and Natham Stillman. **SCIENCE EDUCATION FOR ELEMENTARY SCHOOL TEACHERS**. Boston: Allyn and Bacon, 1960. 399 pp.
- Taylor, John K., Phoebe Knippling and Falcouer Smith. **PROJECT IDEAS FOR YOUNG SCIENTISTS**. 1530 P Street, N. W., Washington, D. C.: Joint Board of Science Education, 1960. 173 pp. \$1.25.
- UNESCO. **700 SCIENCE EXPERIMENTS FOR EVERYONE**. Garden City, New York: Doubleday and Co., 1958. 221 pp.
- Victor, Edward. **SCIENCE FOR THE ELEMENTARY SCHOOL**. New York: Macmillan, 1965. 754 pp.

Professional Periodicals

THE SCIENCE TEACHER

National Science Teachers Assn., 1201 Sixteenth Street, N. W., Washington, D. C., 20036. Library, \$10. Included with individual memberships \$8.00.

SCIENCE AND CHILDREN

National Science Teachers Assn., 1201 Sixteenth Street, N. W., Washington, D. C. 20036. Library, included with THE SCIENCE TEACHER or \$4.00. Included with elementary membership \$4.00.

See page 196 for instructions on making pocket inside back cover to contain curriculum materials.

SUGGESTIONS FOR INSERTING CURRICULUM PLANS INSIDE BACK COVER

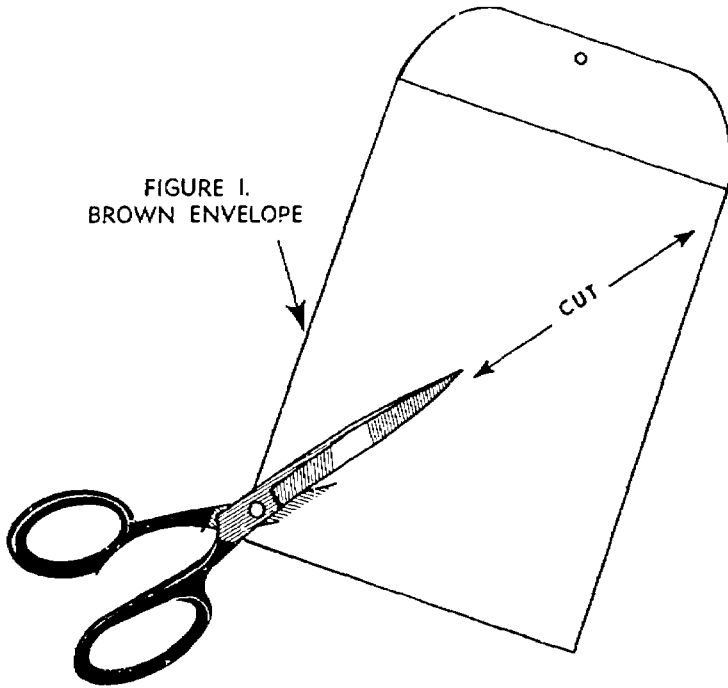

FIGURE I.
BROWN ENVELOPE

1. Cut corner from brown paper envelope (9" x 12") or larger, as shown in Figure I. Shaded area is portion you will use.
2. Glue shaded portion of envelope inside back cover of this bulletin, as shown in Figure II.
3. Apply cellophane self-sticking tape or library tape around edges for reinforcement.
4. Pocket formed by envelope corner will hold 10 to 20 sheets of bond paper not larger than 8" x 10½", or about a dozen 8½" x 11" sheets folded in half. Standard 8½" x 11" sheets can be made to fit by trimming margins.
5. Inserting curriculum plans in the manner suggested will keep them available for frequent reference.

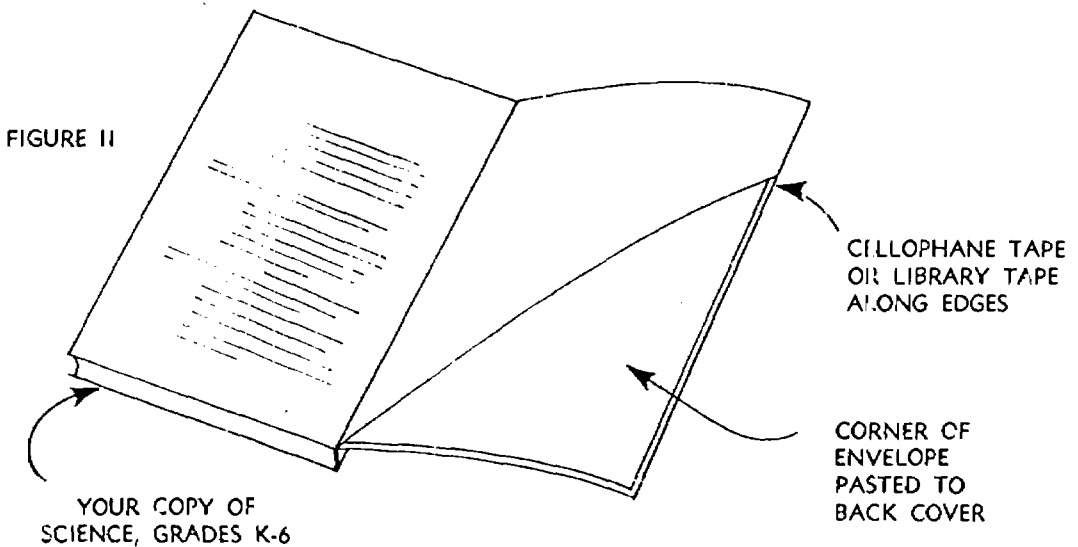

FIGURE II

YOUR COPY OF
SCIENCE, GRADES K-6

CELLOPHANE TAPE
OR LIBRARY TAPE
ALONG EDGES

CORNER OF
ENVELOPE
PASTED TO
BACK COVER