

DOCUMENT RESUME

FD 048 141

SP 007 003

AUTHOR Bennett, Fay, Ed.; And Others
TITLE The Brevard County Reading Laboratory Manual.
INSTITUTION Brevard County Board of Public Instruction,
Titusville, Fla.
PUB DATE 30 Jun 70
NOTE 271p.
EDRS PRICE MF-\$0.65 HC-\$9.87
DESCRIPTORS *Curriculum Guides, *Individualized Reading,
*Reading Clinics, *Reading Games, *Reading Programs

ABSTRACT

GRADES OR AGES: K-12. SUBJECT MATTER: Reading laboratories. ORGANIZATION AND PHYSICAL APPEARANCE: The six chapters of the guide deal with (1) the roles and relationships of the reading laboratory teacher, principal, curriculum coordinator, reading clinician, classroom teacher, and pupil; (2) utilization of reading laboratory facilities, including design, equipment, and storage facilities; (3) pupil placement and scheduling; (4) individualized approach, with descriptions of recommended diagnostic instruments and the design of programs for individual pupils; (5) materials and equipment; and (6) a selected bibliography. The guide is xeroxed and spiral-bound in a plastic binder. OBJECTIVES AND ACTIVITIES: The guide is intended to offer solutions to the problems facing the reading laboratory teacher, and to facilitate the effective use of the laboratory. Chapters 4 and 5 contain information on activities and diagnostic tests. INSTRUCTIONAL MATERIALS: Chapter 5 gives a detailed listing of materials, equipment, and reading games, by skills and instruction and interest level, together with publishers and other sources. STUDENT ASSESSMENT: Chapter 4 details procedures for evaluating student progress and reporting to the pupil, parents, and principal and instructional staff. (MBM)

ED048141

THE BREVARD COUNTY
READING LABORATORY MANUAL

U.S. DEPARTMENT OF HEALTH,
EDUCATION & WELFARE
OFFICE OF EDUCATION
THIS DOCUMENT HAS BEEN REPRO-
DUCED EXACTLY AS RECEIVED FROM
THE PERSON OR ORGANIZATION ORIG-
INATING IT. POINTS OF VIEW OR OPIN-
IONS STATED DO NOT NECESSARILY
REPRESENT OFFICIAL OFFICE OF EDU-
CATION POSITION OR POLICY.

Brevard County Schools
Brevard County, Florida
June 30, 1970

Prepared and Edited by:

Mrs. Fay Bennett, Reading Clinician
Mrs. Kathy Eward, Reading Clinician
Dr. Barbara Row, Reading Clinician

Thomas G. Etheredge, Jr.
Project Director

Steering Committee

R. Dale Weizenecker, Assistant Superintendent for Instruction
Thomas G. Etheredge, Jr., Director of Instruction, Central Area
Lloyd Sougiers, Director of Instruction, South Area
John Forbes, Director of Instruction, North Area
Mrs. Helen Outlaw, Principal, Gemini Elementary School
Mrs. Patricia Eyster, Principal, Audubon Elementary School
Mr. Boyce Padgett, Principal, Hoover Junior High School
Mr. Clifford Estes, Principal, Imperial Estates Elementary School

BREVARD COUNTY SCHOOLS

School Board

Clark Maxwell, Jr., Chairman
Mrs. Norman R. Keegan
S. K. Baker, Jr.
Mrs. Elizabeth K. Dent
G. W. Hedman

Dr. Wayne H. White, Superintendent
Charles R. Green, Sr., Deputy Superintendent

Dr. Luther Rogers, Superintendent, North Area
Mr. Gordon Crouch, Superintendent, Central Area
Dr. G. J. Wheeler, Superintendent, South Area

**Division of Instruction
(Task Force)**

R. Dale Weizenecker, Assistant Superintendent
for Instruction

Dr. David Owens, Director, Instructional Programs
and Materials Center

Mrs. Aletha Rucki, Director, In-Service

John Forbes, North Area Director of Instruction

Thomas G. Etheredge, Jr., Central Area Director
of Instruction

Lloyd Soughers, South Area Director of Instruction

FOREWORD

In the school year 1968-69 the Brevard County school system adopted the concept of placing a reading teacher in each school. During that school year the concept was expanded to create a reading laboratory in each school.

The in-service workshops held prior to the opening of the 1969-1970 school year were not sufficient to instruct the reading laboratory teachers in the procedures necessary to utilize both the facilities and the approach that the reading laboratory offered to the pupil deficient in the area of reading skills.

The guidelines created for the purpose of "giving direction" to the reading laboratory teacher were found to be an excellent starting point, but limited in the areas in which teachers of reading were most inadequate.

This "Teacher Manual" for the Reading Laboratory was begun in an effort to offer some possible solutions to the problems that faced the reading laboratory teacher at both the elementary and secondary school levels.

The Teacher Manual consists of six chapters which contain information relative to the reading laboratory approach. Included are topics which range from the roles of the school personnel who contribute to the reading laboratory operation to the utilization of the materials, equipment, and space of the physical plant designated as the reading laboratory.

The Reading Laboratory Teacher Manual offers the possibility for the information contained to be employed by the teacher individually, or in in-service groups.

TABLE OF CONTENTS

CHAPTER I - The Reading Laboratory - Roles and Relationships

The Role of the Reading Laboratory Teacher	1
The Role of the Reading Laboratory Teacher and the Principal	1
The Role of the Reading Laboratory Teacher and the Curriculum Coordinator	1
The Role of the Reading Laboratory Teacher and the Reading Clinician	1
The Role of the Reading Laboratory Teacher and the Classroom Teacher	2
The Role of the Reading Laboratory Teacher and the Pupil	3

CHAPTER II - The Reading Laboratory - Utilization of Reading Laboratory Facilities

Designing the Reading Laboratory	1
Placement of Equipment	1
Listening Centers	2
Reading Centers	2
Viewing Centers	3
Instructional Centers	4
Storage of Equipment	4
Placement of Materials	4
Reading Laboratory Plans	5
No. 1 Classroom	6
No. 2 Classroom	7
Portable	8
Learning Lab	9
Conference Room	10
Storage Cabinet	11

CHAPTER III - The Reading Laboratory - Pupil Placement and Scheduling

Elementary	1
Eligibility of Pupils for Reading Laboratory Program	1
Staffing Procedures	1
Referral Procedures	2
Pupil Priorities	2
Scheduling	2
Long Range Planning	3
Secondary	4
Eligibility of Pupils for Reading Laboratory Program	4
Referral Procedures	4
Recommended Class Size	5
Pupil Priorities	5
Long Range Planning	5
Referral Form	7

CHAPTER IV - The Reading Laboratory - An Individualized Approach

Initial Procedures for Individualizing Instruction	1
Recommendations	1
Elementary School	1
Junior High School	1
Senior High School	1
Further Diagnostic Procedures	1
Descriptions of Recommended Diagnostic Instruments	2
California Reading Tests	2
Dolch 220 Word List	2
Gates-MacGinitie Reading Tests	4
Gray Oral Reading Tests	4
Interest and/or Attitude Inventory	4
Scott, Foresman Inventory-Survey Tests	4
Spache Diagnostic Reading Scales	7
St. Louis Spelling Tests	7
Analysis of Spelling Errors, List 1	9
Analysis of Spelling Errors, List 2	10
Designing Individual Pupil Programs-for-Learning	11
Master Plan	11
Master Plan A	12
Master Plan B	13
Master Plan C	14
Individual Pupil Program-for-Learning	11
Individual Program A	15
Individual Program B	16
Individual Program C	17



CHAPTER IV - (Continued)- The Reading Laboratory - An Individualized Approach

Evaluation of Pupil Programs	18
Reporting Pupil Progress	18
To the Pupil	18
To the Parents	18
To the Principal and Instructional Staff	18
Recording Pupil Progress	18
Pupil Progress Record	19

CHAPTER V - The Reading Laboratory - Materials and Equipment - An Annotated Resource File

Foreword	111
Option Reading Laboratories	1
Presentation of Option Concept	1
Elementary Option Laboratories	2
Equipment	2
Materials	3
Games	23
Junior High Option Laboratories	25
Equipment	25
Materials	26
Senior High Option Laboratories	45
Equipment	45
Materials	46
Materials and Equipment (Recommended and Approved)	65
Elementary	65
Secondary	67
Listing of Materials by Skills and Instructional and Interest Level	69
Auditory Discrimination	69
Comprehension	69
General Reading Skills	77
Handwriting	85
Independent Readers	85
Language Development	93
Letter and Number Recognition	93
Listening Skills	94
Perceptual Development	95
Phonics	98
Rate	102
Readiness	103
Reference	103
Spelling	104

CHAPTER V - (Continued) - Materials and Equipment - An Annotated Resource File

Listing of Materials by Skills and Instructional and Interest Level (Continued)

Structural Analysis	105
Study Skills	106
Visual Discrimination	107
Vocabulary	107
Description of Materials, Equipment and Educational Reading Games	119
Listing of Publishers, Representatives, and Vendor Codes	203
Index	213

CHAPTER VI - The Reading Laboratory - A Selected Bibliography

Professional Literature for the School Library	1
Elementary	1
General Information and Reference	1
Principles of Teaching Reading	2
Remedial Reading	3
Perceptual Development	3
Phonics	3
Reading and Listening Aids	4
Secondary	4
General Information and Reference	4
Principles of Teaching Reading	4
Remedial Reading	5
Reading in the Content Areas	5
Professional Literature for the Reading Laboratory (Elementary and Secondary)	6

CHAPTER I

THE ROLE OF THE READING LABORATORY TEACHER

The Reading Teacher and Reading Laboratory of a given school are classified by the school board and State Department as a special unit. Therefore, the utilization of this unit is unique to regular teacher assignment.

THE READING LABORATORY TEACHER AND THE PRINCIPAL

The principal will be most influential in the development of the Reading Laboratory. Specific responsibilities will include: selection of a highly trained and qualified teacher to conduct the program; coordination of the various professional personnel involved in the selection of pupils and the operation of the laboratory; and guidance in budgeting, planning, and implementing the program.

In essence, the principal will establish the atmosphere in which the reading laboratory will operate. The quality of this atmosphere will determine the success of the program.

THE READING LABORATORY TEACHER AND THE CURRICULUM COORDINATOR

The curriculum coordinator is primarily responsible for the total developmental reading program within the school. The reading laboratory teacher may serve to give assistance in this area, but due to the demands of the reading laboratory organization and maintenance, this role for the reading laboratory teacher will be minor.

The curriculum coordinator may assist the reading laboratory teacher in the evaluation of pupil test data and the scheduling of pupils from throughout the school.

THE READING LABORATORY TEACHER AND THE READING CLINICIAN

The Area Superintendent's staff includes the area reading clinician who works directly with the principals, coordinators, and teachers within the area schools. This staff member is also available to provide inservice leadership for reading laboratory teachers and to aid in planning and implementing inservice programs in corrective and developmental reading.

The area reading clinician is available as a consultant to principals in establishing a reading laboratory in the school and/or assisting in the continued development of the reading program.

The clinician is also available to principals to interview candidates for reading laboratory positions in terms of forming judgments relative to technical knowledge relating to reading. The principal is responsible for general professional judgments and actual employment, with approval of the Area Superintendent.

The clinician may assist the reading teacher in the physical organization of the reading laboratory and the proper utilization of the materials and equipment. The clinician is available to aid in evaluating the overall appropriateness and adequacy of the materials in a given reading laboratory.

The area reading clinician is available to the reading laboratory teacher for technical assistance in diagnosing individual reading problems and formulating reading laboratory programs and may assist in the selection of diagnostic tests to determine the reading deficiencies involved.

The area reading clinician is available to the reading laboratory teacher as a technical resource person to plan and to implement programs for individuals working in the school reading laboratory and to help the reading laboratory teacher to re-evaluate these programs during the school year.

THE READING LABORATORY TEACHER AND THE CLASSROOM TEACHER

The reading laboratory teacher may serve as a consultant to classroom teachers in identifying materials and needs of particular pupils. This function is generally applicable as a child leaves the laboratory program and is making his adjustment to the regular developmental program. Due to the number of pupils needing the reading teacher's assistance in the laboratory, this secondary role must remain very limited.

The findings of the reading laboratory teacher in regard to pupils referred to the reading laboratory, whether accepted or not accepted into the reading program, should be shared during conferences with the teacher or teacher-team from which the pupil was referred. Conferences with classroom teachers and/or teacher-teams should be scheduled during the year on a regular basis.

Discussions of a child's reading problems should be limited to those persons that are involved in contributing to a solution.

Conferences with parents of pupils within the reading laboratory program, whether concerning the reading laboratory directly or indirectly, should include the reading laboratory teacher, who is a part of that pupil's teaching team.

The primary task of the reading laboratory teacher is to work with the severely disabled reader, using corrective methods and techniques for the purpose of correcting reading deficiencies to the degree that a pupil can re-enter the developmental reading program in the regular classroom setting and

continue progress in reading at a reasonably successful rate and an acceptable degree of proficiency.

All duties of the reading teacher, other than working directly with low achieving pupils in very small groups, will not exceed 20% of the working day.

The organization and planning of the reading laboratory program is the responsibility of the reading laboratory teacher.

THE READING LABORATORY TEACHER AND THE PUPIL

The reading laboratory teacher, being aware of the characteristics of the disabled reader, will avoid thrusting the pupil into situations and experiences that will defeat the purpose of the reading laboratory approach.

The pupil's initial reaction to the reading laboratory may determine the value that he may receive from the reading laboratory program. Therefore, this experience should be planned carefully so that the first experience within the reading laboratory will be successful and rewarding.

The initial testing or evaluation in the reading laboratory program should be kept to a minimum.

The individual program-for-learning should provide goals in order that the student may note his progress and formulate new goals.

continue progress in reading at a reasonably successful rate and an acceptable degree of proficiency.

All duties of the reading teacher, other than working directly with low achieving pupils in very small groups, will not exceed 20% of the working day.

The organization and planning of the reading laboratory program is the responsibility of the reading laboratory teacher.

THE READING LABORATORY TEACHER AND THE PUPIL

The reading laboratory teacher, being aware of the characteristics of the disabled reader, will avoid thrusting the pupil into situations and experiences that will defeat the purpose of the reading laboratory approach.

The pupil's initial reaction to the reading laboratory may determine the value that he may receive from the reading laboratory program. Therefore, this experience should be planned carefully so that the first experience within the reading laboratory will be successful and rewarding.

The initial testing or evaluation in the reading laboratory program should be kept to a minimum.

The individual program-for-learning should provide goals in order that the student may note his progress and formulate new goals.

ORGANIZATION OF THE READING LABORATORY

DESIGNING THE READING LABORATORY

The reading laboratory teacher should design the reading laboratory to accommodate the location of the reading laboratory within the school. The design should include the equipment and the materials that are presently available to equip the reading laboratory.

The design should also include such working areas as are appropriate to the reading laboratory approach. Some variation of design is possible to reflect the approach utilized by the individual reading laboratory teacher.

The designs for five reading laboratories are included in this chapter. Two are rectangular shaped classrooms converted to reading laboratories, one is a conference room in an open space school, one a former learning laboratory, and finally a portable classroom used as a reading laboratory.

PLACEMENT OF EQUIPMENT

The placement of equipment is a major factor in the reading laboratory due to (1) consideration which must be made regarding its use, and (2) the quantity of equipment available.

The reading laboratory teacher should take into consideration the following points in creating the design for the laboratory:

1. Listening Centers

Aud-X. The Aud-X equipment requires an electrical outlet. Working and seating space will be required for 5-6 pupils. A screen for projection is required. The use of this machine is limited due to the levels of accompanying materials available.

Language Master. The Language Master is best used by one or two pupils working at one time. An electrical outlet is required. Placement should be in an area where distraction is at a minimum. Accompanying materials should be adjacent to the machine. Instruction as to the proper operation of the machine should be given to the reading pupil and/or group at the beginning of the school year. The teacher should acquaint herself with the instructor control of the machine for recording and erasure of the blank cards. The ear piece of the headsets used with the Language Master should be of soft type.

Record Player. Electrical outlets are required. The headset equipment should be utilized so that the listening area will not distract other work or instruction being done in the reading laboratory. A seating area with a working-writing surface should be provided for 2-6 pupils. The area is best located in a section of the reading laboratory that is isolated from the other areas.

Tape Recorder. Electrical outlets are required. The headset equipment should be utilized so that the listening area will not distract other work or instruction being done in the reading laboratory. A seating area with a working-writing surface should be provided for 2-6 pupils. The area is best located in a section of the reading laboratory that is isolated from the other areas. Individual tape recorder with earplug may be used at independent study areas.

2. Reading Centers

Controlled Reader, Jr. A 3-prong electrical outlet is required. The Junior Readers are designed to be used by the individual pupil and projected on a surface about 24 inches from the machine. Film-

strips and workbooks to be used by the pupils should be placed adjacent to the area. The juniors are best placed where their use will not distract other work or instruction being done in the reading laboratory. The reading laboratory teacher should study the manual before using and mark those sections to which she will need to refer in making out individual programs. Instruction in the use of the machine should be given to the pupils before they begin their independent work.

Controlled Reader (Large). A 3-prong electrical outlet is required. The large controlled reader is best used with a small group of pupils. The filmstrips used with the large controlled reader should be carefully selected by the reading laboratory teacher. Those most appropriate for reading laboratory use with the machine are the MT, AD, and Comprehension Power series. A screen will be needed and working-seating space should be provided. This machine is used for teacher-directed activities. The accompanying manual should be studied for proper operating procedures.

Craig Reader. An electrical outlet is required. The machine may be utilized by one pupil at a time. Placement should be made in an isolated location with working-writing space provided. Materials accompanying the readers should be adjacent to the area.

Hoffman Reader. An electrical outlet is required. The machine is best used by one or two pupils at one time. Placement should be made in an isolated location with working-writing space provided. Materials accompanying the reader should be adjacent to the work area.

3. Viewing Centers

Filmstrip Projector. A working area for 3 to 10 pupils should be provided. The best situation is to locate the filmstrip projector on a portable stand. An electrical outlet is required. Individual viewers, if used, should be used at a set carrel or a desk with an electrical outlet nearby.

Tachistoscope. An electrical outlet is required. Placement should include a seating area for a small group of pupils with a working-writing surface. A projection screen may be utilized. The accompanying manual should be studied by the reading laboratory teacher to learn the operating procedures for this machine, as well as the instructions concerning the correct selection of materials for pupils.

T-Matic. An electrical outlet is required. Placement should be made in an isolated area so that working with the machine will not disturb other work in the reading laboratory. The machine is best used by a small group of pupils, teacher-directed, and for only a brief time each period. The reading laboratory teacher should acquaint herself with the materials available for use with the machine as well as the operating procedures.

4. Instructional Centers

Small Group Areas. Small group areas should be provided for in the design of the reading laboratory. This area would include seating-working-writing space for the class group for teacher-directed instruction.

Independent Study Area. Independent study areas should be provided in the reading laboratory for the pupil working independently. The area should provide comfortable seating-writing-working space, proper lighting, and be adjacent to the materials that the pupil will need.

Visual displays to accent and identify each of the areas within the reading laboratory lend motivation to the reading laboratory program and the learning environment.

STORAGE OF EQUIPMENT

The storage of equipment may be necessary due to the physical location of the reading laboratory. Those reading laboratories that are located in portable classrooms should consider the addition of a storage cabinet for equipment. A drawing of a cabinet designed for this purpose is included in this chapter.

PLACEMENT OF MATERIALS

The placement of materials should be made after consideration of its function in the reading laboratory approach. Materials to be used by the

pupil as a part of the individual pupil programming should be placed adjacent to the area in which the work is to be done. The materials should be properly labeled by: (1) series name, and (2) level for the convenience of the pupil and the teacher.

Materials not used frequently should be stored and filed.

Materials and/or folders for group use should be placed where the teacher may direct the pupils to distribute them readily.

Materials, manuals, and similar items should be placed adjacent to the area where the reading laboratory teacher will conduct pupil conferences and plan individual programs.

26' X 31'

INDEPENDENT READING

WET CARREL

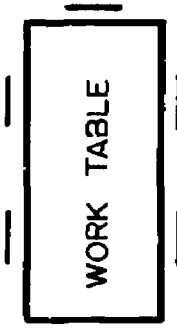

WORK TABLE

WET CARREL

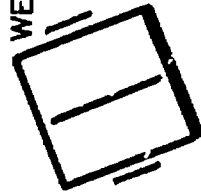

WET CARREL

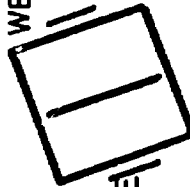

STORAGE

TEACHER'S
DESK

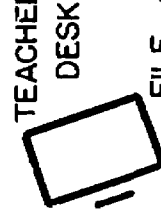

LISTENING
STATION



FILE STORAGE



PUPIL MATERIALS



SMALL GROUP
INSTRUCTION

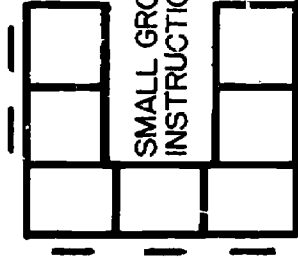

GAME TABLE



BLACKBOARD

NO. 1 READING LABORATORY - CLASSROOM

24' X 26'

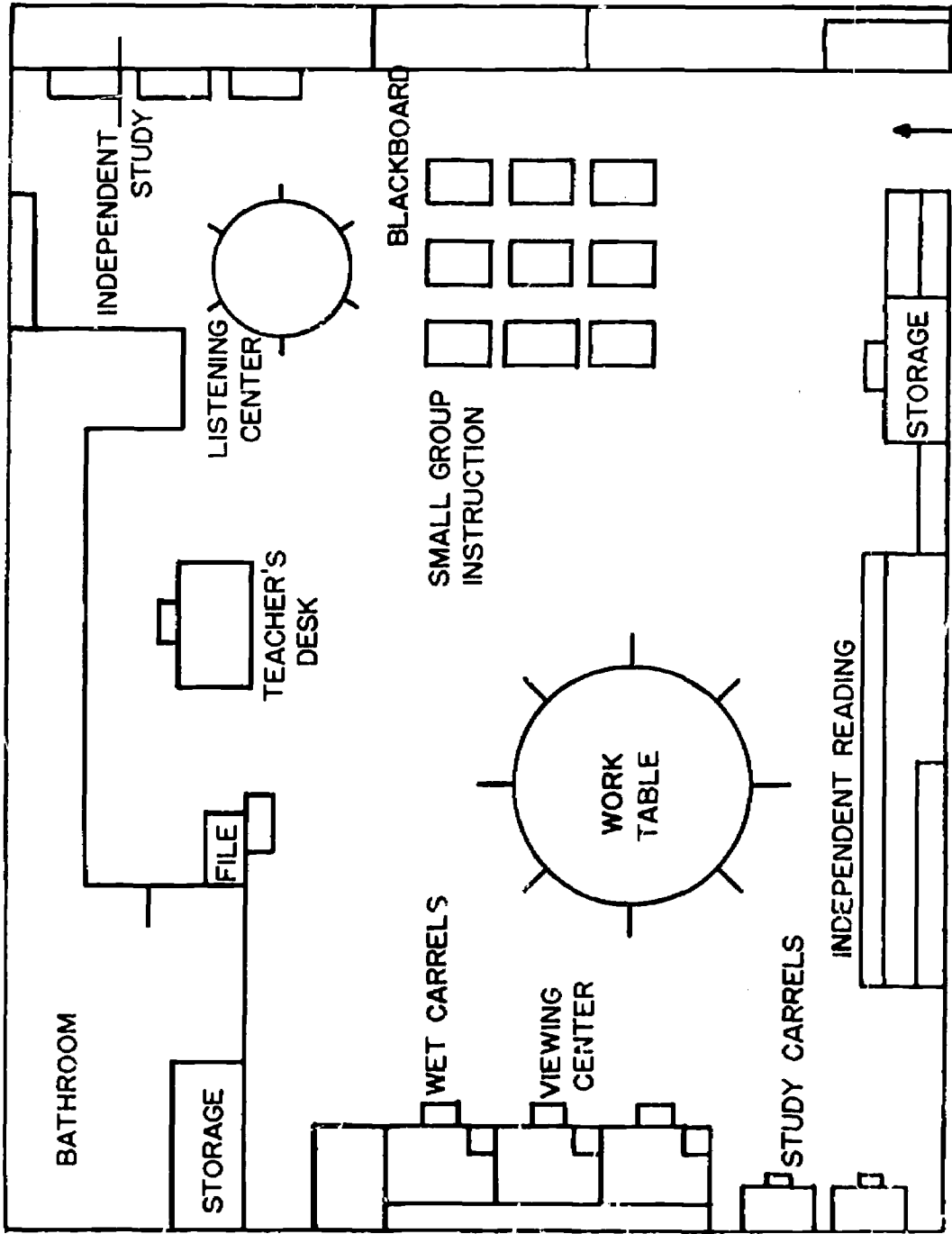

READING LABORATORY - CLASSROOM NO. 2

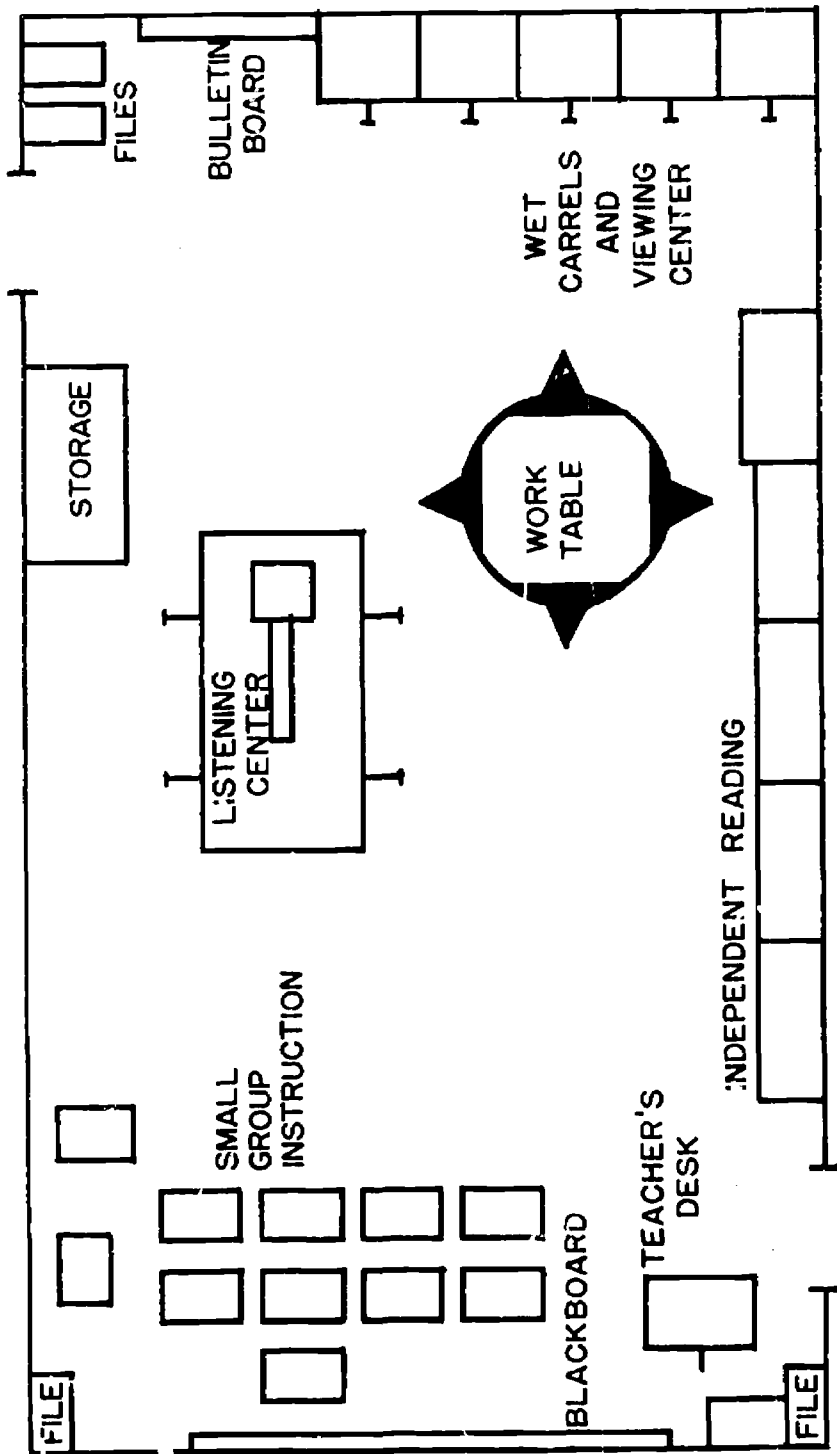

READING LABORATORY - PORTABLE 19'6" X 35'6"

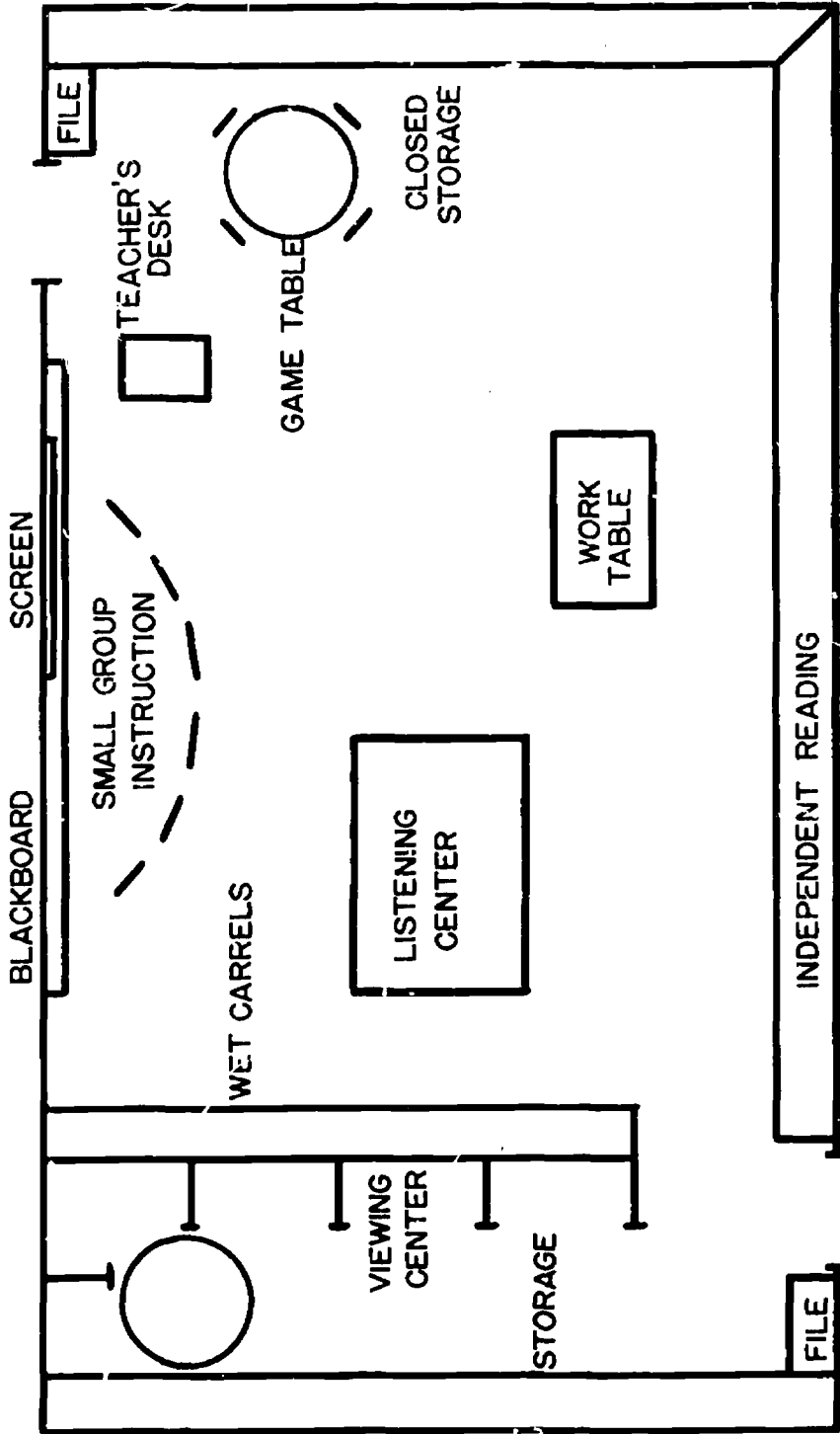

READING LABORATORY - "LEARNING LAB" 21'X35'

17.5' X 28.5'

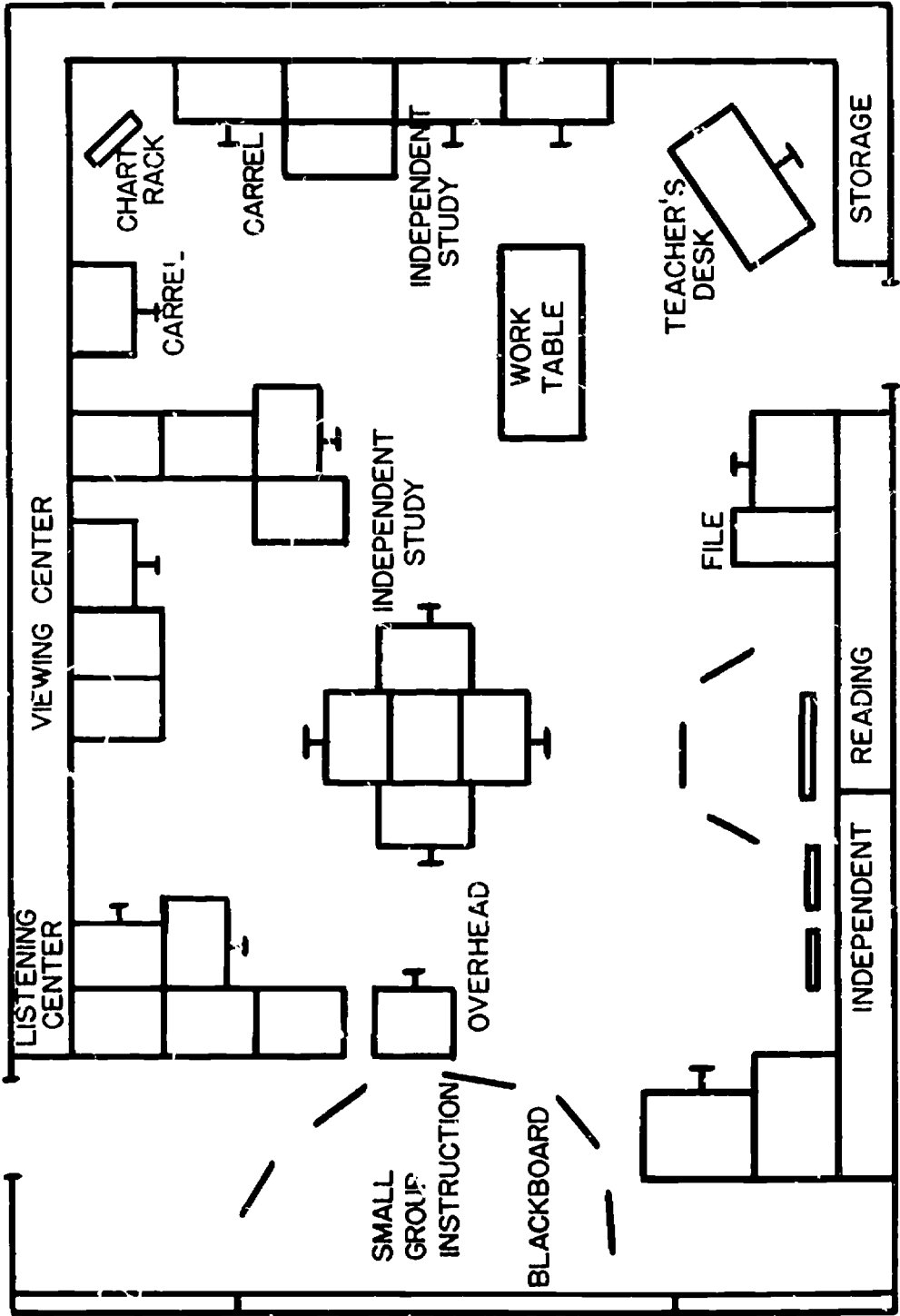

READING LABORATORY - CONFERENCE ROOM

PORTABLE READING LAB CABINETS

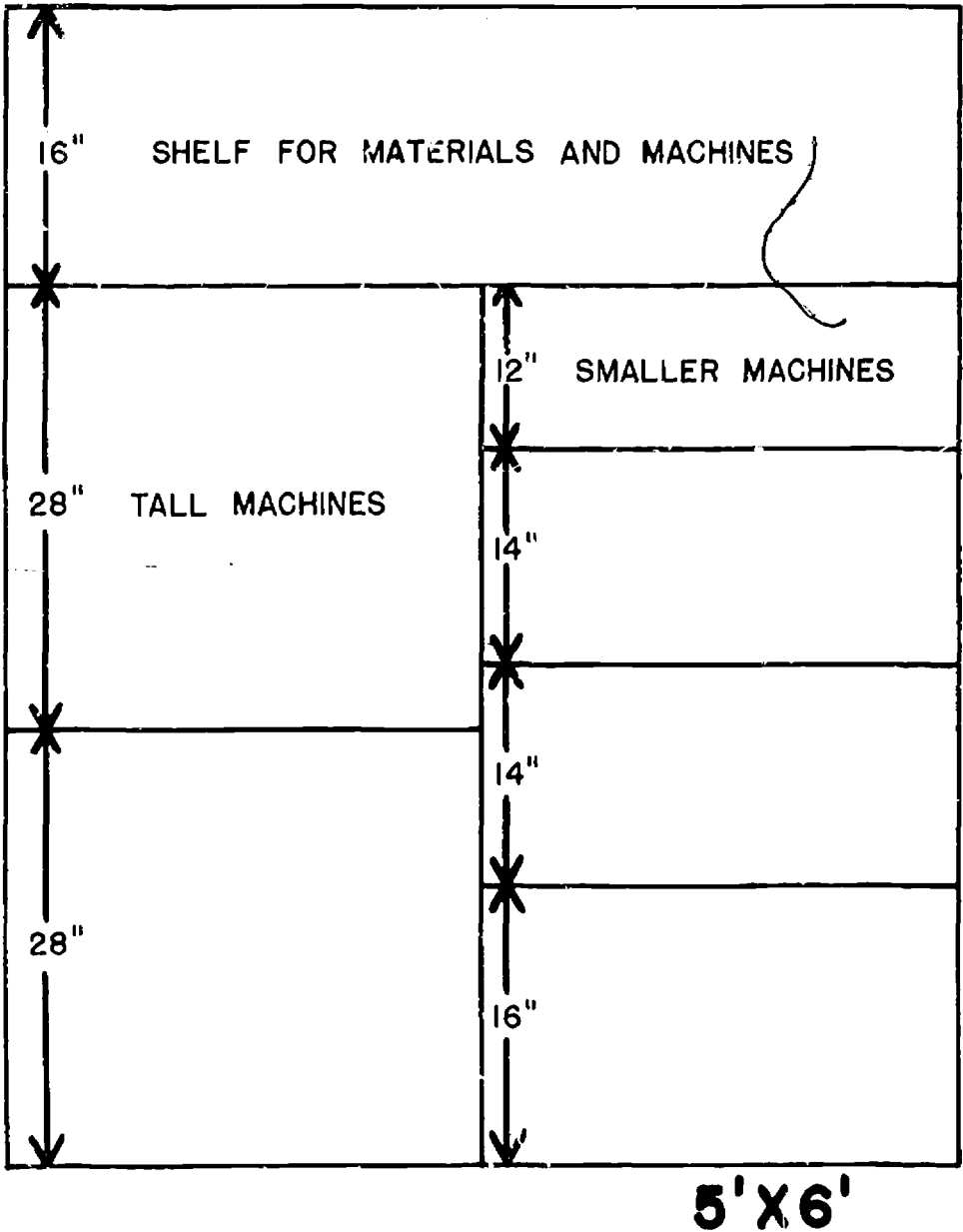

CHAPTER III

THE READING LABORATORY

Pupil Placement and Scheduling

One of the major considerations in the organizational process of a program is the determination of those who will participate. This chapter outlines basic procedures for pupil selection, placement, and scheduling to more successfully implement the reading laboratory program at each school level.

Pupil Placement and Scheduling (Elementary)

Eligibility of pupils for the Reading Laboratory Program. The nucleus from which pupils will be selected at this level will be those pupils presently receiving classroom reading instruction in the Open Highways program or some other special program for low achievers in reading.

Note: A pupil who has been staffed and determined to be eligible for existing exceptional education programs and where, in fact, placement is available, is ineligible for participation in the reading laboratory program.

Staffing Procedures. Poor communications concerning the pupils referred and pupils selected to participate in the reading laboratory program may lead to the misunderstanding of the function of the reading laboratory program within the school. To prevent this situation, as many of the staff as are required for clear communication should be involved in the selection of the pupils for the reading laboratory program.

Initial pupil testing and screening for the reading laboratory program is the primary responsibility of the reading laboratory teacher with the assistance and advice of the school instructional staff. The reading laboratory program is the normal extension of the regular school program for pupils involved. To be productive, this program must be considered a total staff responsibility.

"Evaluation must be continuous.

Actually evaluation is the final act of continual diagnosis. It involves many of the same processes as diagnosis, i.e., an evaluation of the child's skill development and reading effectiveness. Evaluation of past performance can be considered diagnosis for future instruction; therefore, evaluation is continuous.

"Evaluation must be objective.

Objective measures of performance should be used in an effort to control bias. One often reads evaluation reports which state that the teachers and pupils were enthusiastic about the progress which had been made. Although this enthusiasm is a factor which is highly

desirable, it cannot be the basis for evaluation of program effectiveness. Non-objective evaluation techniques are certainly valuable and are not to be precluded by this principle. However, the principle that the basis of the evaluation must be as objective as possible in nature, still holds." *

Referral Procedures. Pupils must be referred to the reading laboratory program at such time when the pupils' failure to progress in the classroom reading program is so severe as to require the attention of the reading laboratory teacher.

Section I of the recommended Reading Laboratory Referral Form (see page 7) should be completed for the reading laboratory teacher. The classroom reading teacher should be aware that referral to the reading laboratory program does not indicate acceptance into the program.

The reading laboratory teacher will schedule a conference with the referring teacher and other personnel as designated by the principal. Discussion during this conference will aid in determination of the most appropriate reading program for the pupil.

Pupil Priorities. The needs of each school's student population will determine the priority given to candidates for the reading laboratory program.

Diagnostic reading tests may be given to aid in determining the degree of the reading deficiencies of the candidates referred. A review of the information available (conference, test data, pupils previously enrolled, etc.) would aid in determining those pupils within a given school most in need of the reading laboratory program. The reading laboratory teacher would make recommendations concerning priorities to the principal. The final decision of the pupils to be enrolled is determined by the principal.

Scheduling. In the process of individualizing instruction in a reading laboratory program, teaching and planning is a continuous and inter-related function; therefore, planning periods as such do not meet the need of this role. A part of each period would be utilized by the reading laboratory teacher to denote the subsequent day's activities in the individual program-for-learning. Periods of time with each small group would vary. The following conditions will exist in all laboratory situations:

1. Each pupil in the reading laboratory program will be seen on a daily basis.
2. The minimum time period for any laboratory group will be one-half hour. Up to one hour of the reading teacher's day may be utilized on a one-to-one pupil-teacher ratio. (Three individuals at twenty minutes each - maximum.)

* Wilson, Robert M., *Diagnostic and Remedial Reading for Classroom and Clinic*. Columbus, Ohio, Merrill Publishing Company; 1967; p. 191.

3. Minimum Daily Load - 30 pupils.

Maximum Daily Load - 60 pupils.

Sixty percent of the pupils must have spent less than four years in school. Research has indicated that the longer a reading problem exists, the more difficult it is to correct that reading problem.

The reading laboratory teacher should prepare the list of reading laboratory students and a schedule of all classes. This list should be submitted to the principal for final approval and a copy distributed to the entire staff.

Long Range Planning - Elementary

APRIL

Tentative plans are established for the following school year.

Plan for the desired post tests or additional information needed on pupils.

Plan for teacher/parent conferences.

MAY-JUNE

Firm up plans for the following school year.

Schedule conferences with classroom teachers regarding the pupil's progress with advice from the teacher as to further need of remedial reading laboratory instruction.

Schedule conference with classroom reading teacher and parent of current laboratory pupils to plan summer follow-up activities (whether formal program or home reading schedule).

Evaluate, with the aid of the principal, the contributions and areas for improvement of the reading laboratory program.

Establish the priorities for materials and/or equipment purchases.

Materials and/or equipment not to be utilized during the summer should be stored during the summer months.

AUGUST

Discuss with teachers (both individually and in groups) the relationship of the reading laboratory program within the total reading program including: pupil eligibility, referral procedures, pupil priorities, etc.

Become known as a reading resource person.

SEPTEMBER

Administer diagnostic reading tests for entries to the reading laboratory.

Review work folder, former diagnostic testing of pupils continuing from previous year. Test as required.

Schedule conferences with the staff involved with each pupil.

Compile the final schedule of pupils in the Reading Laboratory Program for principal approval and disperse the final schedule to the staff.

Regular scheduled instruction under way (as early as possible in September).

OCTOBER-MARCH ON-GOING Program

Informal pupil evaluations should be made daily.

Formal pupil evaluations (not standardized testing) should be made at least once a month.

Long range plans should be reviewed monthly.

Contact with classroom teachers should be maintained weekly concerning pupils in laboratory. Communications should remain open to allow new students to enter laboratory.

The principal should be notified of pupils with severe reading disabilities who are not progressing satisfactorily. The reading laboratory teacher should consult the reading clinician to re-evaluate the program for such a child.

SECONDARY SCHOOL PUPIL PLACEMENT AND SCHEDULING

Eligibility of Pupils for the Reading Laboratory Program. Pupil placement in the reading laboratory program at this level is based upon the pupil's choice of the course offered. This was, in turn, based on: (1) phase recommendation, and (2) teacher evaluation of classroom performance in reading.

Note: A pupil who has been staffed and determined to be eligible for existing exceptional education programs and where, in fact, placement is available, is ineligible for participation in the reading laboratory program.

Referral Procedures. During the course of the school year, it may become necessary for classroom teachers to refer pupils to the reading laboratory program. These referrals should only be initiated by the classroom teacher when there is sufficient evidence that the pupil's

failure to achieve in the classroom is due to a reading problem so severe as to require the attention of the reading laboratory teacher. The referral to the reading laboratory does not indicate acceptance into the reading program.

A recommended referral form is reproduced on page 7.

Scheduling - Secondary

Pupils enrolled in the reading laboratory program will be seen daily unless enrolled in a special program in conjunction with the laboratory program.

Recommended Class Size

Phase I. It is recommended that Phase I Reading Laboratory be limited to a minimum of 8 students and a maximum of 15 students.

Phase II. Classes should be a minimum of 12 students and a maximum of 20 students.

Note: Class sizes should not exceed the maximum but may vary below the maximum to meet the needs of the individual school.

Pupil Priorities. The needs of each school's student population will determine the priority given to candidates for the reading laboratory program. The responsibility for establishing procedures used to determine priorities within the school lies with the administration.

Long Range Planning - Secondary

APRIL

Tentative plans are established for the following school year.

Plan for the desired post tests or additional information needed on pupils.

MAY-JUNE

Firm up plans for the following school year.

Evaluate, with the aid of the principal, the contributions and areas for improvement of the reading laboratory program.

Establish the priorities for materials and/or equipment purchases.

Materials and/or equipment not to be utilized during the summer should be stored during the summer months.

AUGUST

Discuss with teachers (both individually and in groups) the relationship of the reading laboratory program within the total reading

program including: pupil eligibility, referral procedures, pupil priorities, etc.

SEPTEMBER

Administer diagnostic reading tests for entries to the reading laboratory.

OCTOBER-MARCH
ON-GOING Program

Informal pupil evaluations should be made daily.

Formal pupil evaluations (not standardized testing) should be made at least once a month.

Long range plans should be reviewed monthly.

The principal should be notified of pupils with severe reading disabilities who are not progressing satisfactorily. The reading laboratory teacher should consult the reading clinician to re-evaluate the program for such a child.

READING LABORATORY PROGRAM---REFERRAL FORM

SECTION I.

PUPIL'S NAME _____ YEAR LEVEL _____ BOY _____ GIRL _____

TEACHER _____ ROOM _____ PUPIL'S AGE _____

CAUSE OF REFERRAL: _____

PRESENT INSTRUCTIONAL READING LEVEL: _____

PRESENT INSTRUCTIONAL READING MATERIALS: _____

SECTION II. (TO BE COMPLETED DURING CONFERENCE)

Is the pupil enrolled in this school for the first time this year? _____

Was the pupil previously enrolled in a reading laboratory program? _____

Has the pupil attended a summer reading program? _____ Year _____

Has the pupil been retained in any year level? _____ Year _____

Does the pupil have problems in any of the following areas:

Vision _____ Hearing _____ Speech _____ Emotional Disturbance _____

Physical Handicap _____ Other _____

Pupil's achievement in other subject areas is _____

Review of psychological testing information indicates: _____

What are some of the pupil's specific weaknesses or needs in reading? _____

How does pupil's attention span compare with the other children's? _____

Is he a behavioral problem in the class or in a small group? _____

Last Scott, Foresman Mastery or Survey Test Information: (State test and date - other standardized reading achievement or diagnostic test may be used if available.)

Note: The percentiles of the subtests should be cited. Also compare these scores against previous tests scores. Proper evaluation of these results can be most helpful.

SECTION III.

Conference conclusion:

- _____ 1. Placement of the pupil's name on the list of those eligible for the reading laboratory program. Final selection will be determined on the basis of priority.
- _____ 2. Pupil will not benefit from the reading laboratory approach. The pupil should be placed in _____ and receive re-enforcement in the following skills: _____
- _____ 3. Further testing will be done by the reading laboratory teacher and another conference held to determine the future placement of the pupil in reading.

CHAPTER FOUR

THE READING LABORATORY -- AN INDIVIDUALIZED APPROACH --

INITIAL PROCEDURES FOR INDIVIDUALIZING INSTRUCTION

A work folder will be maintained on each pupil enrolled in the reading laboratory program. It will include all diagnostic testing and other evaluative instruments as recommended for the various school levels. The work folder will also include samples of the pupil's work, ranging from the time of entry to dismissal from the reading laboratory program, a statement indicating the nature of the pupil's reading problem, and designated activities projected to alleviate the reading disability.

Elementary School Recommendations. At this level in the reading laboratory program it is recommended that the work folder of the pupil also include: (1) the Dolch Word List, (2) the St. Louis Spelling Test, and (3) the Spache Diagnostic Reading Scales.

Junior High School Recommendations. At this level in the reading laboratory program it is recommended that the work folder of each pupil also include: (1) the St. Louis Spelling Test, (2) an interest and attitude inventory, and (3) a diagnostic reading test.

Diagnostic reading tests recommended are: (1) Spache Diagnostic Reading Scales, (2) Gates-MacGinitie Survey Reading Tests, Level D or E, or (3) Scott, Foresman Intermediate or Upper Level Inventory-Survey Test. Descriptions of these tests are summarized later in this chapter.

Senior High School Recommendations. At this level in the reading laboratory program it is recommended that the work folder of the pupil also include: (1) the St. Louis Spelling Test, (2) an interest and attitude inventory, and (3) a diagnostic reading test.

Diagnostic reading tests recommended are: (1) Spache Diagnostic Reading Scales, (2) Gray Oral Reading Tests, (3) Gates-MacGinitie Reading Tests, Level D or E, or (4) California Reading Tests. Descriptions of these tests are summarized later in this chapter.

Further Diagnostic Procedures. The reading laboratory teacher may ascertain that information obtained from the completion of the requirements for the pupil folder is not sufficient to thoroughly plan the individual pupil program-for-learning. The area Reading Clinician should be consulted in regard to the selection of a diagnostic instrument most appropriate for the determination of the individual reading problem or further diagnosis of the reading problem.

Description of Tests

California Reading Tests. These group tests cover the skills of reading in the following areas: vocabulary, comprehension, following directions, reference skills, and interpretation of material in the content areas.

The tests are available in levels covering grades 7-9, or 9-14. Four forms are available at each level, total time of administration is 68 minutes, and the tests are hand scored.

Dolch Word List*. The Basic Sight Word Test devised by Dolch is a listing of 220 words, excluding nouns, which make up 50% - 75% of all ordinary reading matter. Since the words are not in context, the list is a good measure of the sight vocabulary of the pupil. Re-checks may be made as frequently as necessary to determine progress. A raw score of words correct on the Dolch Word List may indicate the following instructional levels:

<u>Dolch Words Known</u>	<u>Equivalent Reading Level</u>
0- 75	Pre-Primer
76-120	Primer
121-170	First Year
171-210	Second Year or Above
Above 210	Third Year or Above

The Dolch Word List is reproduced on page 3.

* E. W. Dolch. The Basic Sight Word Test.
Champaign, Illinois: Garrard Press, 1942.

DOLCH BASIC WORDS

<u>Pre-Primer</u>	<u>Primer</u>	<u>First Year</u>	<u>Second Year</u>	<u>Third Year</u>
a	all	after	always	about
and	am	again	around	better
away	are	an	because	bring
big	at	any	been	carry
blue	ate	as	before	clean
can	be	ask	best	cut
come	black	by	both	done
down	brown	could	buy	draw
find	but	every	call	drink
for	came	fly	cold	eight
funny	did	from	does	fall
go	do	give	don't	far
help	eat	giving	fast	full
here	four	had	first	got
I	get	has	five	grow
in	good	her	found	hold
is	have	him	gave	hot
it	he	his	goes	hurt
jump	into	how	green	if
little	like	just	its	keep
make	now	let	many	laught
me	no	live	off	light
my	now	may	or	long
not	on	of	pull	much
one	our	old	read	myself
play	out	once	right	never
red	please	open	sing	only
run	pretty	over	sit	own
said	ran	put	sleep	pick
see	ride	round	tell	seven
the	saw	some	their	shall
three	say	stop	these	show
to	she	take	those	six
two	so	thank	upon	small
up	soon	them	us	start
we	that	then	use	ten
where	there	think	very	today
yellow	they	walk	wash	together
you	this	were	which	try
	too	when	why	warm
	under		wish	
	want		work	
	was		would	
	well		write	
	went		your	
	what			
	white			
	who			
	will			
	with			
	yes			

Gates-MacGinitie Reading Test

by Arthur L. Gates and Walter H. MacGinitie

Survey D and Survey E of the Gates-MacGinitie Reading Tests are recommended. Each of these levels of the test has three sections: speed and accuracy (5 minutes), vocabulary (15 minutes), and comprehension (25 minutes). Survey D was designed for grades 4, 5, and 6; Survey E was designed for grades 7, 8, and 9. Three forms for this group test are available from Teachers College Press, Teachers College, Columbia University, 525 West 120th Street, New York, New York, 10027.

Gray Oral Reading Tests

This test measures achievement in oral reading through the use of 13 graded paragraphs of increasing difficulty ranging from pre-primer through adult reading levels. Four comprehension questions follow each selection, but are not included in the scoring since this test is not designed to measure comprehension. An analysis of 8 kinds of oral reading errors is provided by a checklist beside each paragraph.

Four forms of this individualized reading test are available from Bobbs-Merrill Company, Test Division, 4300 West 62nd Street, Indianapolis, Indiana, 46206.

Interest and Attitude Inventory

The Interest and/or Attitude Inventory enables the teacher to become more aware of the unique personality of the pupil. Reports of interest such as the one reproduced here give clues to personality patterns and sources of emotional tension. It also enables the pupil to verbalize his own interests or lack of interests. Attitudes toward reading are received through the responses to sentences 2, 13, 15, 17, 28, 32, 37, 40, and 41. Other sentences give insight into attitudes toward school and study as well as the pupil's goals for the future. An example of an interest inventory is reproduced on page 5.

Scott, Foresman Inventory-Survey Test

This test is most useful to help determine the general achievement of pupils and to determine the particular skill strengths and weaknesses of the pupils.

The test consists of five subtests: word meaning, sentence meaning, paragraph meaning, word analysis, and dictionary skills. Each subtest is arranged in order of difficulty. The test is untimed and is available in both the Intermediate or the Upper Level, with Form A or Form B. The test may be obtained from Scott, Foresman and Company, 1955 Montreal Road, Tucker, Georgia, 30084.

INTEREST AND ATTITUDE INVENTORY

INCOMPLETE SENTENCES*

Here is your chance to write exactly the way you feel. You may write anything you like but it must be what you think.

Answer all questions, do them in order, and do them rapidly.

1. Today I feel _____
2. When I have to read, I _____
3. I get angry when _____
4. To be grown up _____
5. My idea of a good time is _____
6. I wish my parents knew _____
7. School is _____
8. I can't understand why _____
9. I feel bad when _____
10. I wish teachers _____
11. I wish my mother _____
12. Going to college _____
13. To me, books _____
14. People think I _____
15. I like to read about _____
16. On weekends I _____
17. I'd rather read than _____
18. To me, homework _____
19. I hope I'll never _____
20. I wish people wouldn't _____
21. When I finish high school _____

22. I'm afraid _____
23. Comic books _____
24. When I take my report card home _____
25. I am at my best when _____
26. Most brothers and sisters _____
27. I don't know how _____
28. When I read math _____
29. I feel proud when _____
30. The future looks _____
31. I wish my father _____
32. I like to read when _____
33. I would like to be _____
34. For me, studying _____
35. I often worry about _____
36. I wish I could _____
37. Reading science _____
38. I look forward to _____
39. I wish _____
40. I'd read more if _____
41. When I read out loud _____
42. My only regret _____

* The Reading Teacher, Vol. 10, No. 4, April 1957, Page 197.

Diagnostic Reading Scales

by George D. Spache

The Spache Diagnostic Reading Scales is recommended as a standardized informal reading inventory. The Scales identify reading deficiencies that interfere with adequate reading. It consists of a series of graduated scales containing three word recognition lists, twenty-two reading passages, and six supplementary phonics tests. The graded word recognition lists are used to obtain the level of performance at which a pupil should be introduced to the reading passages. The passages yield (1) oral reading instruction level, (2) silent reading independent level, and (3) potential level of auditory comprehension. The six supplementary phonics tests measure the following phonics skills: consonant sounds, vowel sounds, consonant blends, common syllables, blends, and letter sounds. The time limit varies with needs of the child. Available from California Test Bureau, Del Monte Research Park, Monterey, California, 93940.

St. Louis Spelling Test*

The St. Louis Spelling Test will give some measure of grade level achievement and also yield some diagnostic information about phonetic power in spelling.

The test consists of two lists of 32 words each selected from typical second-grade and third-grade spelling vocabularies. The words in the lists are examples of phonetic elements that commonly appear in such vocabularies. The teacher may establish the approximate grade level of achievement in spelling by using the directions and norms suggested.

The reading laboratory teacher may make further use of the tests by noting the pupil's familiarity with the phonetic and structural generalizations within the test vocabulary. A diagnostic chart of the vocabulary and the elements tested is included for this purpose.

The St. Louis Spelling Tests with an accompanying analysis of spelling errors for both Test 1 and Test 2 are reproduced on pages 8, 9, and 10.

* Kottmeyer, William. Teacher's Guide for Remedial Reading. St. Louis: Webster Division, McGraw-Hill Book Company, 1955, p. 88-90.

ST. LOUIS PUBLIC SCHOOLS
DIAGNOSTIC SPELLING TEST

LIST 1

1. not - He is not here.
2. but - Mary is here, but Joe is not.
3. get - Get the wagon, John.
4. sit - Sit down, please.
5. man - Father is a tall man.
6. boat - We sailed our boat on the lake.
7. train - Tom has a new train.
8. time - It is time to come home.
9. like - We like ice cream.
10. found - We found our lost ball.
11. down - Do not fall down.
12. soon - Our teacher will soon be here.
13. good - He is a good boy.
14. very - We are very glad to be here.
15. happy - Jane is a happy girl.
16. kept - We kept our shoes dry.
17. come - Come to our party.
18. what - What is your name?
19. those - Those are our toys.
20. show - Show us the way.
21. much - I feel much better.
22. sing - We will sing a new song.
23. will - Who will help us?
24. doll - Make a dress for the doll.
25. after - We play after school.
26. sister - My sister is older than I.
27. toy - I have a new toy train.
28. say - Say your name clearly.
29. little - Tom is a little boy.
30. one - I have only one book.
31. would - Would you come with us.
32. pretty - She is a pretty girl.

LIST 2

1. flower - A rose is a flower.
2. mouth - Open your mouth.
3. shoot - Joe wants to shoot his gun.
4. while - We sang while we marched.
5. stood - We stood under the roof.
6. third - We are in the third grade.
7. each - Each child has a pencil.
8. class - Our class is reading.
9. jump - We like to jump rope.
10. jumps - Mary jumps rope.
11. jumped - We jumped rope yesterday.
12. jumping - The girls are jumping rope now.
13. hit - Hit the ball hard.
14. hitting - John is hitting the ball.
15. bite - Our dog does not bite.
16. biting - The dog is biting on the bone.
17. study - Study your lesson.
18. studies - He studies each day.
19. dark - The sky is dark and cloudy.
20. darker - This color is darker than that one.
21. darkest - This color is the darkest of the three.
22. afternoon - We may play this afternoon.
23. grandmother - Our grandmother will visit us.
24. can't - We can't go with you.
25. doesn't - Mary doesn't like to play.
26. night - We read to mother last night.
27. brought - Joe brought his lunch to school.
28. apple - An apple fell from the tree.
29. again - We must come back again.
30. laugh - Do not laugh at other children.
31. because - We cannot play because of the rain.
32. through - We ran through the yard.

Directions: Give List 1 to any pupil whose placement is second or third grade.

Give List 2 to any pupil whose placement is above grade 3.

Grade scoring, List 1: Below 15 - below second grade

15 - 22 - second grade

23 - 29 - third grade

Any pupil who scores above 29 should be given the List 2 test.

Grade scoring, List 2: Below 9 - below third grade

9 - 19 - third grade

20 - 25 - fourth grade

26 - 29 - fifth grade

over 29 - sixth grade or better

Any pupil who scores below 9 should be given the List 1 test.

LIST 1

ANALYSIS OF SPELLING ERRORS

<u>Word</u>	<u>Element Tested</u>	<u>Word</u>	<u>Element Tested</u>
1. not	Short Vowels	18. what	wh, th, sh, ch, and ng spellings and ow of long o
2. but		19. those	
3. get		20. show	
4. sit		21. much	
5. man		22. sing	
6. boat	Two vowels together	23. will	doubled final consonants
7. train		24. doll	
8. time	Vowel-consonant-e	25. after	er spelling
9. like		26. sister	
10. found		27. toy ----- oy spelling of a sound	
11. down	ow-ou spelling of ou sound	28. say ----- ay spelling of a sound	
12. soon		29. little ----- le ending	
13. good	long and short oo	30. one	non-phonetic spellings
14. very	final y as short i	31. would	
15. happy		32. pretty	
16. kept	c and k spellings of the k sound		
17. come			

LIST 2

ANALYSIS OF SPELLING ERRORS

<u>Word</u>	<u>Element Tested</u>	<u>Word</u>	<u>Element Tested</u>
1. flover	ow-ou spelling of ou sound, er ending, th spelling	17. study	changing final i before ending
2. mouth		18. studies	
3. shoot	Long and short oo, sh spelling	19. dark	er, est endings
4. stood		20. darker	
5. while	wh spelling, vowel-consonant-e	21. darkest	
6. third		22. afternoon	compound words
7. each	th spelling, vowel before r	23. grandmother	
8. class		ch spelling, two vowels together	24. can't
9. jump	25. doesn't		
10. jumps	double final consonant, e spelling of k sound	26. night	silent gh
11. jumped		27. brought	
12. jumping	addition of s, ed, and ing, j spelling of soft g in sound	28. apple	le ending
13. hit		29. again	non-phonetic spelling
14. hitting	30. laugh		
15. bite	31. because		
16. biting	dropping final e before ing	32. through	

Designing Individual Pupil Programs-for-Learning

The reading laboratory approach is based upon the individualization of instruction. Planning for this type of instruction will, due to this consideration, be of a different type than classroom planning.

Planning should be done in two stages: (1) a master plan (the planning record for the reading laboratory teacher for that group scheduled during the same bloc of time), and (2) individual programs-for-learning.

Master Plan. The master (or teacher) plan is used for one group, for one week; however, this time period may be adjusted to fit the needs of the individual teacher. The plan provides space for the major items utilized by the reading laboratory teacher. The master plan is a compilation of activities designed to obtain previously established short and long range objectives for the pupil involved in the reading laboratory program. Examples of master plans are reproduced on pages 12, 13, and 14.

Individual Pupil Program-for-Learning

The designing of the pupils' individual program-for-learning should provide instruction in, and the utilization of, those materials that would alleviate the pupils' deficiencies in reading. The reading laboratory teacher should utilize those materials, methods, items of equipment and accompanying materials, that provide the instruction deemed necessary by the nature of the pupils' reading difficulties.

The designing of the individual pupil program-for-learning should be completed or reviewed in detail during the pupil-teacher conference in order to establish the individualized approach with the pupil and familiarize the pupil with the materials with which he will be working.

Steps in the designing of the individual program-for-learning are:

1. Based on the teacher's knowledge of the pupils' individual reading difficulties, instructional reading activities are assigned.
2. Notation is made on the teacher master plan and on the individual program-for-learning and assignment of a regular conference time is scheduled.

It is suggested that the teacher keep a copy of the individual programs-for-learning. This copy provides a ready reference to all the activities of all the pupils in the reading laboratory program and establishes a permanent record of pupil activities and placement of materials. A permanent reading laboratory folder may be kept by the teacher. Individual programs-for-learning are reproduced on pages 15, 16, and 17.

MASTER PLAN - A

Class <u>9:15</u>		Week of <u>Oct. 27</u>		to <u>Oct. 31</u>		
Conference	C.R. (lrg)	C.R., Jr.	Listen	Tach-X	Group	Independent
M O N		1. Jane 2. Wayne 3. Bob	Steve Don Terry Bob		Don + Terry W.A. Tapes No. 15 - Camp No. 31 - W.L. Sheets	Jane Jeff Wayne Bob Steve
T U E S		1. Don 2. Terry 3. Jeff	Jane		Don + Terry AD film #3 Read CRA Story - 30	Greg Bob Wayne June Jeff
W E D		1. Jane 2. Wayne 3. Jeff			Don + Terry 2-1 3-1 Read to them II - P. 144	Jane Jeff Wayne Bob Steve
T H U R	Jane Jeff	1. Don 2. Terry 3. Jeff	Steve Bob		Don + Terry AD film #4 Dittos 5, 4	Jane Bob Wayne Jeff
F R I	Don Terry	1. Jane 2. Wayne 3. Bob	Don Terry		Don + Terry W.A. Tapes Worksheets	Jane Jeff Wayne Steve

Note: Master Plan forms may be prepared by the reading laboratory teacher on dittos, one per class, per week. Spaces across the top of the master plan would be filled in by the teacher to accommodate the materials available.

MASTER PLAN - B

FRI.	THRU.	WED.	TUES.	MON.	
Linda	Charles Ricky	Lisa Mike	Jim Marianne	Chris	CONFERENCE
Linda Charles	Linda	Marianne	Charles Lisa	Linda Marianne	T-MATIC
					NEW PRACTICE READER
Linda	Marianne	Charles Lisa	Linda Marianne	Charles Lisa	BARNELL-LOFT
	Mike	Mike Chris			READERS DIGEST
					CONQUESTS
					GATES
					MC-CALL
Ricky Chris	Jim	Chris Jim	Mike		C.R., JR.
Mike		Ricky Marianne	Chris	Mike Jim	LANGUAGE MASTER
Jim	Ricky			Lisa	FLASH-X
				Chris, Mike Ricky, Jim	DETECT VISUAL
Chris	Ricky				DETECT TACTILE
					TANGRAM
Linda Ind. f.s.					FILMSTRIPS
				Charles	MOD PRESS
Charles		Charles Marianne	Lisa Linda	Marianne	STUDY-SCOPE
Marianne	Mike	Linda Lisa	Marianne	Mike	TIME FOR PHONICS
	Chris		Chris		PRIMARY PHONICS
			Chris, Mike Ricky, Jim		OTHER
Jim Ricky	Chris-Lisa Marianne	Mike Ricky	Charles	Linda Ricky	INDEPENDENT READING
	Ricky		Ricky		SULLIVAN
Mike Judy Puzzles	Linda Lisa		Jim Decoding		OTHER
Lisa Marianne		Linda		Chris Charles	SKILLS KIT

MASTER PLAN - C

READING LAB - WEEKLY ASSIGNMENT SHEET

ACTIVITY	MONDAY-TUESDAY	WEDNESDAY	THURSDAY	FRIDAY	COMMENTS
INDIVIDUAL CONFERENCES		Dan - 9 ¹⁵ -25 Gary - 9 ²⁵ -35	John - 9 ¹⁵ -25 Wayne - 9 ²⁵ -35		
CONTROLLED READER	1 2	Dan - 9 ²⁵ -50 EA #10 Gary - 9 ⁵⁵ -10 ¹⁰ CA #7	Sue - 9 ¹⁰ -40 PH #8 Mary - 9 ¹⁰ -35 DA #14		
TACH-X		9 ⁵⁰ -10 ⁰⁰ D 3rd Wayne Bill Mary	9 ⁵⁰ -10 ⁰⁰ C 50 Gary R. John G.	(f. 1m) #2	
LANGUAGE MASTER		Brad } 9 ¹⁰ -25 Phonics III	Dave } 9 ¹⁰ -25 Phonics I		Gary - R Dave - Short answer
TAPE RECORDER		Wayne 9 ²⁵ -40 John 9 ⁴⁵ -10 ¹⁰ Bill Tapes	Rewind Story - into replay		
S.R.A. READING LAB IIIa		John - 9 ¹⁰ -40 Brown Power Bill 9 ¹⁰ -50 Brown Power	Gary - 9 ¹⁵ -50 Orange - PR Mary 9 ³⁵ -50 Alde PR		
READING FOR			Warner		
GROUP		in other O.H. section { Gary { John { Bill { Wayne { Mary	L. L. 1 min We Use (D)	19 min P. Use (Green)	All students

CLASS TIME:
9¹⁰ - 10¹⁰
1 1/2 Wk.

CLASS ROLL

Dave G.	Bill W.
Gary R.	Sue W.
John G.	Mary M.K.
Wayne W.	
Brad H.	

INDIVIDUAL PUPIL PROGRAM - A

PROGRAM-FOR-LEARNING

NAME Jane A. DATE Sept. 16 CLASS 9:15

MATERIALS USED	
	<u>Controlled Reader films B - Listen + Think Tapes D</u> <u>Comprehension Skills (varied materials)</u>
MONDAY	Controlled Reader (films B) - #10 setting 30 Ind. study - SRA Lab (comprehension section only)
TUESDAY	Listen and Think Tapes (D) Ind. comprehension reading - Barnell - Loft Book D
WEDNESDAY	Controlled Reader (B) #11 Ind. study - McCall - Crabb - Book D
THURSDAY	Conference with teacher Ind. study Barnell - Loft - Book D
FRIDAY	Controlled Reader (B) #12 Ind. study - Barnell - Loft and Independent Reading

INDIVIDUAL PUPIL PROGRAM - B

NAME: Chris Roger
 BASIC PROGRAM: Voc., Perception

	Time	9:05 - 9:15 (a)	9:15 - 9:25 (b)	9:15 - 9:25 (9)	9:15 - 9:25 (9)
MONDAY	① Conference: 8:50 - 9:05	② b) 9:05 - 9:15 Detect Visual: Small group instruction	③ b) Skill Kit. Main Idea Primer level		
TUESDAY	a) Language Master Cards: Basic Sight Vocabulary	b) Primary Phonics p. 7 initial consonants	c) Lippincott Pre-Primer Small group instruction AR Source		
WEDNESDAY	a) Reader's Digest Level 1, Part 1 General Comprehension Skills	b) Controlled Reader, Jr. M.T. filmstrips			
THURSDAY	a) Primary Phonics Short a, p. 8	b) Directed Independent Reading 1st Level Books on same shelf.			
FRIDAY	a) Controlled Reader, Jr. M.T. filmstrips	b) Primary Phonics P. 9 Long e Sound			Detect Tactile Lesson

INDIVIDUAL PUPIL PLAN - C
Individual Student Weekly Reading Lab Program

NAME: Dave G.

GRADE: 8 PERIOD: 2

MONDAY Mrs. Jones class: Open Highways, Book 6, Pages 61-62
Chocolate Fudge - Discussion of experiences children have had in cooking something (use of recipes) need to preview certain types of written material
Identify utensils needed, also ingredients
Reread recipe to note sequence
Need to read recipe once more if they are going to actually prepare fudge. Think and Do Book, Page 32.

TUESDAY Mrs. Jones class: Open Highways, Book 6, Pages 63-69
How many made some fudge from yesterday's recipe?
Adventures of Thomas O'Toole: Introduction and Vocabulary
Read; and discuss literal meanings.
O'Toole's fanciful tales - main ideas, context clues
Prefixes; un, dis, and im

WEDNESDAY 9:10-9:50 S.R.A. Reading Lab (Blue) Reading selection and Learn about Words - Go over answers with Dave and discuss any elements of phonetic or structural analysis he is not sure of - check inferential comprehension
S.R.A. Rate Builder - have Dave time himself in this selection - check answers with him.
9:50-10:00 Tach-X (Ask Dave to help Terry get machine set up with correct film (D, #3, 2nd lesson)

THURSDAY 9:10-9:50 Language Master; Review of both long and short vowels (What are some ways we can recognize which sound we will have in unknown words; cvcv and cvcc)
Reading for Understanding: Cards #30 (Careful reading)
Check answers with Dave and discuss any he misses.
9:45-10:00 Review spelling patterns (vc/cv, and v/cv)
Discuss how these can give clues to pronunciation
Have some of both single and multi-syllable words on board for students to analyze.

FRIDAY Games and/or Pleasure Reading
Probe (Be sure that children know definitions of any words they use)
Encourage building "longer" words for more points (how prefixes and suffixes can add to length of words and influence meanings and usage)

SHOW DAVE WEST POINT CATALOG

Evaluation of Pupil Programs

Reporting Pupil Progress

Reports of pupil progress should be made to: (1) the pupil, (2) the parents, and (3) and principal and instructional staff.

To the Pupil.

The pupil in the reading laboratory program should receive continuous information regarding his progress from the reading laboratory teacher through a weekly conference scheduled during the reading laboratory period.

The area reading clinician's assistance in this type of informal pupil program evaluation should be utilized during the school year. Such assistance may serve to benefit the reading laboratory teacher in the development of subsequent program designs.

To the Parent.

The parents of the pupils enrolled in the reading laboratory program should be informed of their child's participation in the program. Reporting of information in regard to pupil progress in the reading laboratory program should be made to the parent at the scheduled report time and also at any point when the information is requested or significant.

To the Principal and Instructional Staff.

The reading laboratory teacher should utilize the post-test evaluative information to establish pupil progress and determine the recommendation for placement for the pupil for the following school year.

A summary of the results of the reading laboratory program should be given to the principal and to those members of the instructional staff involved with the pupils enrolled in the reading laboratory program.

Recording Pupil Progress

The pupil's individual program maintained in the work folder may be used to provide the information necessary to record and report progress. The work folder provides a record of pupil progress and the materials used during the reading laboratory program.

At the completion of a child's study in the reading laboratory, the reading laboratory teacher should complete the Pupil Progress Record for placement in the cumulative folder.

READING LABORATORY
PUPIL PROGRESS RECORD

PUPIL'S NAME _____ YEAR LEVEL _____ DATE _____
TEACHER _____ SCHOOL _____

I. Physical Disabilities

Vision _____ Hearing _____ Speech _____
Other _____

II. Diagnostic Test Information

A. Pre-tests:

TEST	DATE	RESULTS
_____	_____	_____
_____	_____	_____
_____	_____	_____

B. Post-tests:

_____	_____	_____
_____	_____	_____
_____	_____	_____

III. Materials Utilized:

IV. Comments:

CHAPTER V

Materials and Equipment
-An Annotated Resource File-

I.	Foreword	iii
II.	Option Reading Laboratories	1
	Presentation of Option Concept	1
	Elementary Option Laboratories	2
	Equipment	2
	Materials	3
	Games	23
	Junior High Option Laboratories	25
	Equipment	25
	Materials	26
	Senior High Option Laboratories	45
	Equipment	45
	Materials	46
III.	Materials and Equipment (Recommended and Approved)	65
	Elementary	65
	Secondary	67
IV.	Listing of Materials by Skills and Instructional and Interest Level	69
	Auditory Discrimination	69
	Comprehension	69
	General Reading Skills	77
	Handwriting	85
	Independent Readers	85
	Language Development	93
	Letter and Number Recognition	93
	Listening Skills	94
	Perceptual Development	95
	Phonics	93
	Rate	102
	Readiness	103
	Reference	103
	Spelling	104
	Structural Analysis	105
	Study Skills	106
	Visual Discrimination	107
	Vocabulary	107

V.	Description of Materials, Equipment, and Educational Reading Games	119
VI.	Listing of Publishers, Representatives and Vendor Codes	203
VII.	Index	213

FOREWORD

The listings of materials and equipment provided in this chapter were designed to be utilized for the organization and planning of the reading laboratory. The purposes of the listings are varied, for each provides information unique to the other, but pertinent to a definite service for the reading laboratory teacher and/or the administrator.

The following listings are provided for the purpose of locating information concerning each item of material or equipment: (1) a list of publishers, representatives, items included and vendor reference code numbers, (2) description of individual items of materials and equipment, (3) a list of programming information on individual items (stating: (a) skill area, (b) interest level, and instructional level of each item), and (4) a complete index of every item included.

The following listings are provided for the dual purpose of: (A) instructional evaluation of the reading laboratory in individual schools, and (B) determination of selections of additional materials and equipment for the reading laboratory. The listings are: (1) Recommended and Approved materials and equipment list for elementary and secondary schools, and (2) Option Reading Laboratories for elementary, junior high, and senior high schools.

The following persons have made significant contributions to the listings of reading laboratory materials and equipment:

Elementary:

Audubon:	Sara Surret
Golfview:	Susie Fleming
Harbor City:	Patricia Williams
Imperial Estates:	Nancy Elmor
Mila:	Rhoda Kilbourn
Oak Park:	Elizabeth Ryoland
Old Dixie:	Ruth Sanders
Palm Bay:	Mary Penn
Patrick:	Elaine Phares
Pineda:	Evelyn Wilee
Stevenson:	Maxine Carr

Secondary:

Jackson Junior High:	Sylvia Baxley
Clearlake Junior High:	Gail Smith
Kennedy Junior High:	Virginia Schrauger
Hoover Junior High:	Caroline Loftin
Roosevelt Junior High:	Lynn Gelineau
Cocoa High:	Elise Aytes

Special Assistance:

Secretaries:

Theresa Bennett
Dixie Sansom
Marth Willoughby
Shirley Zabilansky

PRESENTATION OF OPTION READING LABORATORIES

The Option Reading Laboratories are designed for: (1) instructional evaluation of the reading laboratory materials and equipment, and (2) to aid in determining additional materials needed within the individual school to provide a balanced program according to the needs of the school.

There are three options at each school level: Elementary, junior high, and senior high. Each succeeding option (I,II,III) provides more depth within a skills area and additional approaches to specific reading problems. EACH OPTION READING LABORATORY ENCOMPASSES ALL MATERIALS INCLUDED IN THE PREVIOUS OPTION(S).

The administrator, with the involvement of key personnel, should select the Option Reading Laboratory which would be most suited to his school's needs. The following summary statements (of the Option Reading Laboratories) should aid in determining the most appropriate Option Reading Laboratory for the school.

Option I. Option I Reading Laboratory materials and equipment provide basic instructional coverage in terms of instructional levels, interest levels, and basic reading skills. An Option I Reading Laboratory is designed to be the foundation for a new reading laboratory and the minimum goal of each school.

Option II. Option II Reading Laboratory provides the essentials (offered in Option I) plus increased depth of instructional materials. Option II should provide an adequate basis for instruction for schools with a student population from a high socio-economic background. The absolute numbers of readers classified as moderate to severely disabled should be less than might be expected in an "average" school.

Option III. Option III Reading Laboratory provides additional depth and variety of materials, allowing extensive and long-term treatment of specific reading disabilities. This Option would be necessary for schools with larger percentages of severely disabled readers.

The intent of the Option Reading Laboratory concept is to provide a means of evaluating the skill areas which are supported by instructional materials. Additional materials should be selected for a laboratory by building up weak skill areas. The option charts would, therefore, be used as a tool for building horizontally I - II, etc. within an area which the staff feels is in need of additional depth.

* Each item (in the Option section) with an asterick (*) also appears in the skills section under the same skill heading.

OPTION READING LABORATORIES

ELEMENTARY

<u>Skill Area: EQUIPMENT</u>		
<p>OPTION I</p> <p>(1) Controlled Reader, Jr. (1) Language Master (1) T-Matic 150 (1) Tape Recorder (1) Headset</p>	<p>OPTION II</p> <p>(2) Controlled Reader, Jr. (1) Language Master (1) T-Matic 150 (2) Tape Recorder (1) Headset (1) Overhead Projector</p>	<p>OPTION III</p> <p>(3) Controlled Reader, Jr. (2) Language Master, Headsets (2) T-Matic 150 Tape Recorder 1 Large 2 Cassette Headsets Filmstrips: Projector Overhead Projector Craig Reader or Hoffman Reader Interval Test Timer Flannel Boards (1) School Skill Tracing Board</p>

OPTIGN READING LABORATORIES

ELEMENTARY

<u>Skill Area: AUDITORY DISCRIMINATION</u>		
<p>OPTION I</p> <p>Eye and Ear Fun, Book 1* Eye and Ear Fun, Book 2* Eye and Ear Fun, Book 3* Eye and Ear Fun, Book 4* Let's See</p> <p>Language Master Cards</p> <p>Ideal Listen-Look Reading Tapes</p>	<p>OPTION II</p> <p>(In addition to Option I items)</p> <p>Time For Sounds* Time For Sounds* Sight and Sound of Phonics</p>	<p>OPTION III</p> <p>(In addition to Option I & II items)</p> <p>Wollensak Teaching Tapes</p>

OPTION READING LABORATORIES

ELEMENTARY

Skill Area: <u>COMPREHENSION</u>		
<p><u>OPTION I</u></p> <p><u>Barnell-Loft Specific Skill Series*</u></p> <p>Drawing Conclusions A Drawing Conclusions B Drawing Conclusions C Drawing Conclusions D Drawing Conclusions F</p> <p>Following Directions A Following Directions B Following Directions C Following Directions D Following Directions E Following Directions F</p> <p>Getting the Facts A Getting the Facts B Getting the Facts C Getting the Facts D Getting the Facts E Getting the Facts F</p> <p>Getting the Main Idea A Getting the Main Idea B Getting the Main Idea C Getting the Main Idea D Getting the Main Idea E</p>	<p><u>OPTION II</u></p> <p>(In addition to Option I items)</p> <p><u>Comprehension Power Series*</u></p> <p>Controlled Reader, Set C-3 Controlled Reader, Set C-4 Controlled Reader, Set C-5 Controlled Reader, Set C-6</p> <p>Decoding for Reading</p> <p>Readers Digest Practice Pads</p> <p><u>Controlled Reader Filmstrips*</u></p> <p>Cr-DD (One Album) Cr-E (One Album) Cr-EE (One Album)</p> <p><u>Merrill Linguistic Readers*</u></p> <p>Linguistic Reader 1 Linguistic Reader 2 Linguistic Reader 3 Linguistic Reader 4 Linguistic Reader 5 Linguistic Reader 6</p>	<p><u>OPTION III</u></p> <p>(In addition to Option I & II items)</p> <p><u>Hoffman Reader Programs*</u></p> <p>Primary Achievement Units 3rd Achievement Units 4th Achievement Units 5th Achievement Units</p> <p><u>Gates-Pearson Reading Exercises</u></p> <p>Elementary - SA Elementary - RD Elementary - FD</p> <p>SRA Pilot Library IIa* SRA Pilot Library IIb*</p> <p>Ideal Listen-Look-Learn Reading Tapes*</p>

OPTION READING LABORATORIES

ELEMENTARY

<p>Skill Area: <u>COMPREHENSION</u></p>	<p>OPTION I</p> <p><u>Barnell-Loft Specific Skill Series*</u> CONT</p> <p>Locating the Answer A Locating the Answer B Locating the Answer C Locating the Answer D Locating the Answer E Locating the Answer F</p> <p>Using the Context A Using the Context B Using the Context C Using the Context D Using the Context E Using the Context F</p> <p>McCall-Crabbe Series</p> <p>New Readers' Digest Skillbuilders</p> <p>Listen and Think Tapes</p> <p><u>Controlled Reader Filmstrips</u></p> <p>CR-A (Two Albums) CR-S (Two Albums)</p>	<p>OPTION II</p> <p>(In addition to Option I items)</p> <p><u>Reading for Concepts (A-H)*</u></p> <p>Reading for Concepts A Reading for Concepts B Reading for Concepts C Reading for Concepts D Reading for Concepts E Reading for Concepts F Reading for Concepts G Reading for Concepts H</p> <p>Reading for Understanding, Junior Edition*</p>	<p>OPTION III</p> <p>(In addition to Option I & II items)</p> <p>(See Preceding Page)</p>
---	--	---	--

<p>Skill Area: <u>COMPREHENSION</u></p>	<p><u>OPTION I</u></p> <p><u>Controlled Reader Filmstrips con't</u></p> <p>CR-C (Two Albums) CR-D (Two Albums)</p> <p><u>New Practice Readers*</u></p> <p>New Practice Readers, Book A New Practice Readers, Book B New Practice Readers, Book C New Practice Readers, Book D New Practice Readers, Book E New Practice Readers, Book F New Practice Readers, Book G</p>	<p><u>OPTION II</u></p> <p>(In addition to Option I items) (See Preceding Page)</p>	<p><u>OPTION III</u></p> <p>(In addition to Option I & II items) (See Preceding Page)</p>
---	--	---	---

OPTION READING LABORATORIES

ELEMENTARY

Skill Area: <u>GENERAL</u>		
<p><u>OPTION I</u></p> <p><u>Merrill Linguistic Readers</u></p> <p><u>Reader's Digest New Reading Skill Builders*</u></p> <p>Level 1 Part I Part II</p> <p>Level 1.1 Part I Part II</p> <p>Level 2 Part I Part II</p> <p>Level 3 Part I Part II</p> <p>Level 4 Part I Part II</p> <p>Level 5 Part I Part II</p> <p><u>Sullivan Programmed Reading *</u></p> <p>Book 1 Book 3 Book 5 Book 2 Book 4 Book 6</p>	<p><u>OPTION II</u></p> <p>(In addition to Option I items)</p> <p><u>McCall-Crabbe Series</u></p> <p>McCall-Crabbe, Book A McCall-Crabbe, Book B McCall-Crabbe, Book C McCall-Crabbe, Book D McCall-Crabbe, Book E</p> <p><u>Reader's Digest Practice Pads</u></p> <p>Practice Pad 1 Practice Pad 2 Practice Pad 3</p> <p><u>Singer Structural Series*</u></p> <p>Pupil Books Key-Picture Cards Sound Picture Cards Reading Dominoes Vocabulary Development Booklets</p> <p><u>Universal Workbooks in Phonics</u></p> <p>Universal Workbooks in Phonics (1) Universal Workbooks in Phonics (2a)</p>	<p><u>OPTION III</u></p> <p>(In addition to Option I & II items)</p> <p><u>Gates-Pearson Reading Exercises</u></p> <p><u>Miami Linguistic Readers*</u></p> <p>Biff and Tiff Kit, Kit and the Catfish Nat the Rat Tug Duck and the Buzz Bug The Sack Hut On the Rock in the Pond The Picnic Ship Hot Corn Muffins! The Camping Trip The Magic Bean Chang's Shell Dick's Cat Rumplestiltskin On Sunfish Island Mark's Jet Matt and the Black Cat B Is For Bicycle White Horse The Man on the Penny The Twin Mystery</p>

OPTION READING LABORATORIES

ELEMENTARY

Skill Area: <u>GENERAL</u>		
<p>OPTION I</p> <p><u>Sullivan Programmed Reading</u> con't</p> <p>Book 7 Book 12 Book 17 Book 8 Book 13 Book 18 Book 9 Book 14 Book 19 Book 10 Book 15 Book 20 Book 11 Book 16 Book 21 (To be utilized with Sullivan Storybooks)</p>	<p>OPTION II</p> <p>(In addition to Option I items)</p> <p><u>Universal Workbooks in Phonics</u> con't</p> <p>Universal Workbooks in Phonics (2b) Universal Workbooks in Phonics (3a) Universal Workbooks in Phonics (3c) Universal Workbooks in Phonics (4a) Universal Workbooks in Phonics (4b) Universal Workbooks in Phonics (5)</p> <p><u>Webster Reading Clinic 10X*</u></p> <p>Conquests in Reading The Magic World of Dr. Spello Reading Skill Cards New Webster Word Wheels The Everyreader Series Group Word Teaching Game Basic Sight Vocabulary Cards</p>	<p>OPTION III</p> <p>(In addition to Option I & II items)</p> <p>(See Preceding Page)</p>



OPTION: READING LABORATORIES

ELEMENTARY

Skill Area: <u>INDEPENDENT READERS</u>	OPTION I	OPTION II (In addition to Option I items)	OPTION III (In addition to Option I & II items)
<u>Dolch Readers*</u>	Big, Bigger, Biggest Dog Pals Friendly Birds I Like Cats In the Woods Making Friends On the Farm Some are Small Tommy's Pets Zoo Is Home Once There Was A Rabbit Once There Was An Elephant Once There Was A Monkey Once There Was A Dog	<u>Phonetic Reading Series*</u> Mac and Tab The Tin Man A.I. Ben Bug Ed Ted The Wig <u>Wildlife Adventure Series*</u> Gatie the Alligator Sleeky the Otter Skipper the Dolphin Tawny the Mountain Lion Boulder the Jackrabbit Thor the Moose Ruff the Wolf Arctos the Grizzly	<u>Phonetic Readers Series*</u> Puss in Boots Jack the Giant Killer Jack and the Beanstalk Aladdin and the Wonderful Lamp Ali Baba and the Forty Thieves Robinson Crusoe <u>Royal Road Miniature Readers*</u> Pip, the Pet Rabbit Jilli's Best Frock The Picnic The Robins The Bull-dog and the Kitten The Swimming Lesson The Kitten and the Stamps The Cat and the Bed <u>We Read More Stories Series*</u> The Three Billy Goats Gruff The Old Woman and Her Pig Little Sambo Aesop's Fables The Three Bears The Little Red Hen
<u>Sullivan Storybooks, Classroom Library Set*</u>	Sullivan Storybook, Classroom Library Set		
<u>The Time Machine Series</u>	Leonard Visits Space Leonard Visits the Ocean Floor Leonard Discovers America		

<p>Skill Area: <u>INDEPENDENT READERS</u></p>	<p>OPTION I</p> <p><u>The Time Machine Series* con't</u></p> <p>Leonard Visits Dinosaur Land Leonard Visits Sitting Bull Leonard Goes to the Olympics Leonard Equals Einstein Leonard Discovers Einstein</p>	<p>OPTION II</p> <p>(In addition to Option I items)</p> <p>(See Preceding Page)</p>	<p>OPTION III</p> <p>(In addition to Option I & II items)</p> <p><u>We Read More Stories Series* con't</u></p> <p>The Engine That Could The Gingerbread Boy The Boy and the Goats The Little Red Hen and the Fox The House That Jack Built All Mine and Kindness Nursery Rhymes The Wishing Book Gentle As A Lamb How the Robin Got His Red-Breast Winter Summer Spring Fall</p>
---	--	---	--

OPTION READING LABORATORIES

ELEMENTARY

<u>Skill Area: LETTER AND NUMBER RECOGNITION</u>		
<p>OPTION I</p> <p><u>Flash-X Programs*</u></p> <p>Set X-1 Readiness Pictures Set X-2 Primary Recognition Set X-3 Basic Accuracy-Numbers Set X-4 Basic Accuracy-Letters Set X-5 Sight Vocabulary Set X-6 Sight Vocabulary Set X-10 Sight Vocabulary</p> <p><u>T-Matic Filmstrips*</u></p> <p>Letter Recognition ROF-1</p>	<p>OPTION II</p> <p>(In addition to Option I items)</p> <p><u>Flash-X Programs*</u></p> <p>Set X-12 Spelling Level 2 Set X-13 Spelling Level 3 Set X-14 Spelling Level 4</p>	<p>OPTION III</p> <p>(In addition to Option I & II items)</p> <p><u>Teaching Typewriter Programs*</u></p> <p>Animals Friends Discovering Colors Exploring Numbers 1-5 Learning to Count Alphabet Progression Reading and Spelling (Beginners) Reading and Spelling (Fun with Words) - 2 Sets Exploring Numbers 1-10 Opposites - 10 Concepts</p>

<p>Skill Area: <u>LISTENING SKILLS</u></p>	<p><u>OPTION I</u> Wollensak Teaching Tapes Introduction to the Listening Experience Sounds At Home Sounds We See Walking Sounds</p>	<p><u>OPTION II</u> (In addition to Option I items) <u>Listen and Think Series (Tapes)</u> Listen and Think A-R Listen and Think B Listen and Think C Listen and Think D</p>	<p><u>OPTION III</u> (In addition to Option I & II items) (Teacher-adapted and/or Teacher-made materials can be developed.)</p>
--	--	--	--

OPTION READING LABORATORIES

ELEMENTARY

<p><u>Skill Area: PERCEPTUAL DEVELOPMENT</u></p>			
<p><u>OPTION I</u></p>	<p><u>Detect Tactile*</u></p> <p><u>T-Matic Filmstrips*</u></p> <p>Span of Perception PTF-3 (20 Filmstrips)</p> <p>Letter Recognition ROF-1 (20 Filmstrips)</p> <p>Words and Phrases VCF-1 (20 Filmstrips)</p> <p>Words and Phrases VCF-2 (20 Filmstrips)</p> <p>Words and Phrases VCF-3 (20 Filmstrips)</p>	<p><u>OPTION II</u></p> <p>(In addition to Option I items)</p> <p><u>Frostig Development Program*</u></p> <p><u>Frostig Test Material*</u></p> <p>Frostig Test Specimen Set</p> <p>Frostig Test Booklets</p> <p>Frostig Program Box</p> <p><u>Shapes Around Us Series *</u></p> <p>What Is Round?</p> <p>What Has Three Sides?</p> <p>What Has Four Sides?</p> <p>What Comes In A Box?</p> <p>What Shape Is It?</p> <p><u>TRY Experience For Children*</u></p> <p><u>Winter Haven Lions Program*</u></p> <p><u>Tangrams*</u></p>	<p><u>OPTION III</u></p> <p>(In addition to Option I & II items)</p> <p><u>School Skill Tracing Board*</u></p> <p><u>Tachistoscope Filmstrips*</u></p> <p>Set ABC Basic Accuracy Filmstrips</p> <p>Perceptual Readiness - Set 10</p> <p>Primary Letters - Set 21</p>

OPTION READING LABORATORIES

ELEMENTARY

<p><u>Skill Area: PHONICS</u></p>		
<p><u>OPTION I</u></p> <p><u>Barnell-Loft Specific Skills*</u></p> <p>Working with Sounds A Working with Sounds B Working with Sounds C Working with Sounds D</p> <p><u>Language Master Cards and Programs*</u></p> <p>Blank Cards</p> <p>Primary Phonics</p>	<p><u>OPTION II</u></p> <p>(In addition to Option I items)</p> <p><u>First Experience with Vowels and Consonants*</u></p> <p>Phonics Is Fun, Book 1 Phonics Is Fun, Book 2 Phonics Is Fun, Book 3</p> <p><u>Language Master Cards and Programs*</u></p> <p>Phonics Program</p> <ol style="list-style-type: none">1. Sound Blending and Beginning Phonetic Skills Set I2. Consonant Blends and Irregular Phonetic Sounds Set II3. Word Building and Word Analysis Techniques <p><u>Phonics We Use Series*</u></p> <p>Phonics We Use, Book A Phonics We Use, Book B Phonics We Use, Book C Phonics We Use, Book D Phonics We Use, Book E</p>	<p><u>OPTION III</u></p> <p>(In addition to Option I & II items)</p> <p>Phonics In A Nutshell</p> <p><u>Ideal Listen-Look-Learn Reading Tapes and Worksheets*</u></p> <p>Initial and Final Consonant (20 Lessons) Blends and Diagraphs (10 Lessons) Vowel Tapes (20 Lessons) Syllable Rule - Accent Clues (16 Lessons)</p> <p><u>Phonics with Write and See*</u></p> <p>Phonics with Write and See, A Phonics with Write and See, B</p> <p><u>Webster Reading Clinic*</u></p> <p>Conquest in Reading The Magic World of Dr. Spello Reading Skill Cards New Webster Word Wheels The Everyreader Series Group Word Teaching Game Basic Sight Vocabulary Cards</p>

OPTION READING LABORATORIES

ELEMENTARY

<p>Skill Area: <u>PHONICS</u></p>	<p>OPTION I (See Preceding Page)</p>	<p>OPTION II (In addition to Option I items) (See Preceding Page)</p>	<p>OPTION III (In addition to Option I & II items) <u>Wollensak Teaching Tapes</u> Word Attack Skills Approx. 50 tapes on recognition and location of long and short vowels and consonants</p>
-----------------------------------	--	---	---

OPTION READING LABORATORIES

ELEMENTARY

<u>Skill Area:</u> <u>RATE</u>		
<p>OPTION I</p> <p><u>Controlled Reader Filmstrips*</u></p> <p>CR-A (Two Albums) CR-B (Two Albums) CR-C (Two Albums) CR-D (One Album)</p>	<p>OPTION II</p> <p>(In addition to Option I items)</p> <p><u>Controlled Reader Filmstrips*</u></p> <p>CR-DD (One Album) CR-E (One Album) CR-EE (One Album)</p> <p>McCall-Crabbe Series</p>	<p>OPTION III</p> <p>(In addition to Option I & II items)</p>

OPTION READING LABORATORIES

ELEMENTARY

<p>Skill Area: <u>REFERENCE</u></p>	<p>OPTION I</p> <p><u>Thesauri*</u></p> <p>In Other Words I A Beginning Thesaurus In Other Words II A Junior Thesaurus</p> <p>Dictionaries and/or Encyclopedias</p>	<p>OPTION II (In addition to Option I items)</p> <p>Dictionaries</p>	<p>OPTION III (In addition to Option I & II items)</p> <p><u>Thorndike-Barnhart Advanced Junior Dictionary (4th Edition)*</u></p>
-------------------------------------	---	--	---

OPTION READING LABORATORIES

ELEMENTARY

<p>Skill Area: <u>SPELLING</u></p>	<p><u>OPTION I</u> The Magic World of Dr. Spello</p>	<p><u>OPTION II</u> (In addition to Option I items) <u>Flash-X Programs*</u> Set X-12 Spelling Level 2 Set X-13 Spelling Level 3 Set X-14 Spelling Level 4 Phonics In A Nutshell</p>	<p><u>OPTION III</u> (In addition to Option I & II items) <u>Teaching Typewriter Programs*</u> Alphabet Progression Reading and Spelling (Beginners) <u>T-Matic Filmstrips*</u> Spelling Word List SDF-2 (30 Filmstrips) Spelling Word List SDF-3 (30 Filmstrips) Spelling Word List SDF-4 (30 Filmstrips) Spelling Principles (30 Filmstrips) Conquests In Reading*</p>
------------------------------------	--	--	--

OPTION READING LABORATORIES

ELEMENTARY

<u>Skill Area: STRUCTURAL ANALYSIS</u>	OPTION I	OPTION II	OPTION III
<u>Study Scopes*</u>	(In addition to Option I items) <u>Ideal Listen-Look-Learn Reading Tapes and Workbooks*</u>	(In addition to Option I & II items) <u>Hoffman Reader Programs*</u>	
Study Scopes	Initial and final Consonant Tapes Blends and Diagraphs Vowel Enrichment Syllable Rule - Accent Clues	Primary Achievement Units (10 Albums per unit) 3rd Level Achievement Units (10 Albums per unit) 4th Level Achievement Units (10 Albums per unit) 5th Level Achievement Units (10 Albums per unit)	
<u>Barnell-Loft Reading Series*</u>			
Working With Sounds (A-F)			

OPTION READING LABORATORIES

ELEMENTARY

<u>Skill Area: VISUAL DISCRIMINATION</u>	
<p><u>OPTION I</u></p> <p>Controlled Reader Filmstrips*</p> <p>CR-MT: Motility Training CR-AD: Accelerated Discrimination</p>	<p><u>OPTION II</u></p> <p>(In addition to Option I items)</p> <p><u>Michigan Tracking Program*</u></p>
	<p><u>OPTION III</u></p> <p>(In addition to Option I & II items)</p> <p><u>Detect Visual Program*</u></p>

OPTION READING LABORATORIES

ELEMENTARY

Skill Area: <u>VOCABULARY</u>			
<p><u>OPTION I</u></p> <p><u>Flash-X*</u></p> <p>Set X-5 Set X-6 Set X-10</p> <p><u>Language Master Cards and Programs*</u></p> <p>Blank Cards Word Picture Program: Nouns and Everyday Things Verbs/Action Words Basic Concepts</p> <p><u>New Practice Readers*</u></p> <p>New Practice Readers, Book A New Practice Readers, Book B New Practice Readers, Book C New Practice Readers, Book D New Practice Readers, Book E</p> <p><u>T-Matic Filmstrips*</u></p> <p>Words and Phrases VCF-1 (20 Filmstrips) Words and Phrases VCF-2 (20 Filmstrips)</p>	<p><u>OPTION II</u> (In addition to Option I items)</p> <p><u>Reading for Concepts (A-M)*</u></p> <p>Reading for Concepts A Reading for Concepts B Reading for Concepts C Reading for Concepts D Reading for Concepts E Reading for Concepts F Reading for Concepts G Reading for Concepts H</p> <p><u>Webster Reading Clinic*</u></p> <p>Conquests in Reading The Magic World of Dr. Spello Reading Skill Cards New Webster Word Wheels The Everyreader Series Group Word Teaching Game Basic Sight Vocabulary Cards</p>	<p><u>OPTION III</u> (In addition to Option I & II items)</p> <p><u>Pilot Library, IIA*</u></p> <p><u>Pilot Library, IIB*</u></p>	



<p>Skill Area: <u>VOCABULARY</u></p>	<p>OPTION I</p> <p><u>T-Matic Filmstrips* con't.</u></p> <p>Words and Phrases VCF-3 (20 Filmstrips)</p> <p>Words and Phrases VCF-4 (20 Filmstrips)</p> <p>Remedial Reading Filmstrips RRF-1 (20 Filmstrips)</p>	<p>OPTION II</p> <p>(In addition to Option I items)</p> <p>(See Preceding Page)</p>	<p>OPTION III</p> <p>(In addition to Option I & II items)</p> <p>(See Preceding Page)</p>
--------------------------------------	---	---	---

OPTION READING LABORATORIES

ELEMENTARY

Skill Area: <u>GAMES</u>	OPTION I	OPTION II (In addition to Option I items)	OPTION III (In addition to Option I & II items)
<u>Phonics</u>	Phonics We Use A and/or B Junior Phonics Rummy	<u>Phonics</u>	<u>Phonics</u>
<u>Basic Vocabulary</u>	Match, Set 1 Match, Set 2 Sight Phrase Cards	Consonant Lotto Dog House Game Take	Phonetic Quizmo Vowel Lotto What the Letters Say
<u>Structural Analysis</u>	Riddle-Rhyme Time, Set A Riddle-Rhyme Time, Set B	<u>Basic Vocabulary</u>	<u>Basic Vocabulary</u>
		<u>Spelling</u>	Read and Say Verb Game
		Spelling Games Kit A and B	

OPTION READING LABORATORIES

JUNIOR HIGH

<u>Skill Area: EQUIPMENT</u>	
<p>OPTION I</p> <p>(2) Controlled Reader, Jr. (2) Language Master (2) T-Matic 150 (1) Tape Recorder (1) Headset</p>	<p>OPTION II</p> <p>(3) Controlled Reader, Jr. (2) Language Master (2) T-Matic (2) Tape Recorder (2) Headset (1) Overhead Projector (1) Tachistoscope (1) Interval Test Timer</p>
	<p>OPTION III</p> <p>(3) Controlled Reader, Jr. (2) Language Master (2) T-Matic 150 (3) Tape Recorder (1) Headset (1) Overhead Projector (1) Tachistoscope (1) Interval Test Timer (1) Craig Reader (1) Hoffman Reader</p>

OPTION READING LABORATORIES

JUNIOR HIGH

Skill Area: <u>COMPREHENSION</u>	OPTION I <u>Barnell-Loft Specific Skill Series*</u> Drawing Conclusions A Drawing Conclusions B Drawing Conclusions C Drawing Conclusions D Drawing Conclusions E Following Directions A Following Directions B Following Directions C Following Directions D Following Directions E Following Directions F Getting the Facts A Getting the Facts B Getting the Facts C Getting the Facts D Getting the Facts E Getting the Facts F Getting the Main Idea A Getting the Main Idea B Getting the Main Idea C Getting the Main Idea D Getting the Main Idea E	OPTION II (In addition to Option I items) <u>Better Reading Books*</u> Better Reading, Book 1 Better Reading, Book 2 Better Reading, Book 3 <u>Comprehension Power Series*</u> Controlled Reader, Set C-3 Controlled Reader, Set C-4 Controlled Reader, Set C-5 Controlled Reader, Set C-6 <u>Controlled Reader Filmstrips*</u> CR-DD (One Album) CR-EE (One Album) CR-FF (One Album) CR-JI (One Album) <u>MacMillan Reading Spectrum*</u> Spectrum of Skills Development Kit Spectrum of Skills (Independent Readers)	OPTION III (In addition to Option I & II items) <u>Craig Reader Programs*</u> C (30 Lessons) C-1 (32 Lessons) C-2 (30 Lessons) C-3 (30 Lessons) C-4 (35 Lessons) C-5 (40 Lessons) <u>Hoffman Reader Programs*</u> 3rd Level Achievement Unit 4th Level Achievement Unit 5th Level Achievement Unit 6th Level Achievement Unit <u>Reading Development Kits*</u> Kit A Kit B Kit C <u>SRA Reading Laboratories*</u> SRA Lab IIIa SRA Lab IIIb
----------------------------------	--	--	---

OPTION READING LABORATORIES

JUNIOR HIGH

Skill Area: <u>COMPREHENSION</u>		
<p>OPTION I</p> <p><u>Barnell-Loft Specific Skill Series*</u> con't</p> <p>Locating the Answer A Locating the Answer B Locating the Answer C Locating the Answer D Locating the Answer E Locating the Answer F</p> <p>Using the Context A Using the Context B Using the Context C Using the Context D Using the Context E Using the Context F</p> <p><u>Controlled Reader Filmstrips*</u></p> <p>CR-B (Two Albums) CR-C (Two Albums) CR-D (One Album) CR-F (One Album) CR-GH (One Album) CR-IJ (One Album)</p>	<p>OPTION II (In addition to Option I items)</p> <p><u>New Modern Reading Skilltexts*</u></p> <p>New Modern Reading Skilltexts, Book 1 New Modern Reading Skilltexts, Book 2 New Modern Reading Skilltexts, Book 3</p> <p><u>New Practice Readers*</u></p> <p>New Practice Readers, Book A New Practice Readers, Book B New Practice Readers, Book C New Practice Readers, Book D New Practice Readers, Book E New Practice Readers, Book F New Practice Readers, Book G</p> <p><u>SRA Pilot Libraries*</u></p> <p>Pilot Library IIb Pilot Library IIc</p> <p><u>McCall-Crabbe Reading Series</u></p> <p>Books C through F</p>	<p>OPTION III (In addition to Option I & II items)</p> <p><u>Gates-Pearson Reading Exercises</u></p> <p>Intermediate SA, FD, RD Advanced SA, FD, RD</p>

<p>Skill Area: <u>COMPREHENSION</u></p>	<p>OPTION I</p> <p><u>Reading for Concepts*</u></p> <p>Reading for Concepts A Reading for Concepts B Reading for Concepts C Reading for Concepts D Reading for Concepts E Reading for Concepts F Reading for Concepts G Reading for Concepts H</p> <p><u>Stories for Teen-Agers*</u></p> <p>Stories for Teen-Agers, Book A, Red Stories for Teen-Agers, Book B, Blue Stories for Teen-Agers, Book C, Yellow Stories for Teen-Agers, Book D, Green</p>	<p>OPTION II</p> <p>(In addition to Option I items)</p> <p><u>Turner-Livingston Communication Series*</u></p> <p>The Language You Speak The Letters You Write The Movies You See The Newspaper You Read The Phone Calls You Make The Television You Watch</p>	<p>OPTION III</p> <p>(In addition to Option I & II items)</p> <p>(See Preceding Page)</p>
---	---	---	---

OPTION READING LABORATORIES

JUNIOR HIGH

Skill Area: <u>GENERAL</u>	OPTION I	OPTION II (In addition to Option I items)	OPTION III (In addition to Option I & II items)
Dr. Spello*	<u>Reader's Digest New Reading Skill Builders*</u>	<u>Adult Readers (Reader's Digest)</u>	<u>Kaleidoscope of Skills*</u>
Level 4	Part I	A Race to Remember First at the Finish	Book 5-1 Red/Silver
Part II	Level 5	Guides to High Adventure	Book 5-2 Gold
Part I	Part I	"I Fell 18,000 Feet"	Book 5-3 Lavender
Part II	Part II	Men Who Dare the Sea	Book 5-4 Olive
Level 6	Level 6	Mystery of the Mountains	Book 6-1 Orange/Aqua
Part I	Part I	Sante Fe Traders	Book 6-2 Tan
Part II	Part II	Second Chance	Book 6-3 Purple
Level 7	Level 7	"Send for Red"	Book 6-4 Lime
Book One	Book One	Valley of 10,000 Smokes	Book 7-1 Rust/Blue
Book Two	Book Two	What's on the Moon?	Book 7-2 Yellow
Level 8	Level 8	Workers in the Sky	Book 7-3 Violet
Book Three	Book Three	<u>Decoding for Reading*</u>	Book 7-4 Green
Book Four	Book Four	Magic World of Dr. Spello	<u>Learning to Read While Learning to Learn*</u>
Reading Attainment I*	Reading Attainment I*	<u>Gates-Pearson Reading Exercises*</u>	The Purple Smail
		Intermediate SA, FD, RD	Happy the Hippo
		Advanced SA, FD, RD	The Peculiar Lawn Mower
		<u>Manpower and Natural Resources Kit</u>	Pedro's Secret
			Dognappers
			Loud and Clear
			Operation Phoenix
			Viceroy's Daughter
			Behind the Scenes
			Rescue on the Mountains
			A Place for Joe

OPTION READING LABORATORIES

JUNIOR HIGH

Skill Area: <u>GENERAL</u>		
OPTION I (See Preceding Page)	OPTION II (In addition to Option I items) <u>McCall-Crabbe Series*</u> McCall-Crabbe, Book A McCall-Crabbe, Book B McCall-Crabbe, Book C McCall-Crabbe, Book D McCall-Crabbe, Book E <u>Reader's Digest Practice Pads*</u> Practice Pad 1 Practice Pad 2 Practice Pad 3 <u>Universal Workbooks in Phonics (1-5)*</u> Universal Workbooks in Phonics (1) Universal Workbooks in Phonics (2a) Universal Workbooks in Phonics (2b) Universal Workbooks in Phonics (3a) Universal Workbooks in Phonics (3b) Universal Workbooks in Phonics (4a)	OPTION III (In addition to Option I & II items) <u>Learning to Read While Learning to Learn*</u> Chilling Escape Hundred Milers Racing the Salt Deadline for Time The Big Break Julius Ceasar <u>New Modern Reading Skilltexts*</u> New Modern Reading Skilltexts, Book 1 New Modern Reading Skilltexts, Book 2 New Modern Reading Skilltexts, Book 3 <u>Sullivan Programmed Reading*</u> Books 1-21

OPTION READING LABORATORIES

JUNIOR HIGH

<p><u>Skill Area: GENERAL</u></p> <p>OPTION I (See Preceding Page)</p>	<p>OPTION II (In addition to Option I items)</p> <p><u>Universal Workbooks in Phonics (1-5)</u> * cont</p> <p>Universal Workbooks in Phonics (45) Universal Workbooks in Phonics (5)</p>	<p>OPTION III (In addition to Option I & II items)</p> <p><u>World of Adventure Series*</u></p> <p>Lost Uranium Mine Flight to the South Pole Hunting Grizzly Bears Fire on the Mountain City Beneath the Sea The Search for Piranha Sacred Well of Sacrifice Viking Treasure</p>
---	---	--

<p>Skill Area: <u>INDEPENDENT READERS</u></p>	<p>OPTION I</p> <p><u>Bowmar Reading Incentive Program*</u></p> <p>Karting The Mighty Midgets Slot Car Racing Motorcycles Drag Racing Teen Fair Horses Surfing Drag Racing - Funny Cars Dune Buggies Dune Buggy Racing Custom Cars</p> <p><u>Morgan Bay Mystery Series</u></p> <p>Mystery of Morgan Castle Mystery of the Marble Angel Mystery of the Midnight Visitor Mystery of the Musical Ghost Mystery of the Missing Marlin Mystery of Monk's Island Mystery of Marauder's Gold Mystery of the Myrmidon's Journey</p>	<p>OPTION II</p> <p>(In addition to Option I items)</p> <p><u>Bowmar Reading Incentive Program*</u></p> <p>Multi-Media Kit</p> <p><u>Checkered Flag Learning System*</u></p> <p>Classroom Reading Kit A Wheels Riddler Bearcat Smashup Classroom Reading Kit B Scramble Flea Grand Prix 500</p> <p><u>Merrill Mainstream*</u></p> <p>Courage Under Fire Against the Odds They Were First In New Directions People Like You</p>	<p>OPTION III</p> <p>(In addition to Option I & II items)</p> <p><u>Checkered Flag Learning System*</u></p> <p>Audio Visual Kit A Audio Visual Kit B</p> <p><u>Deep Sea Adventure Series*</u></p> <p>The Sea Hunt Treasure Under the Sea Submarine Rescue The Pearl Divers Frogmen in Action Danger Below Whale Hunt Rocket Divers</p> <p><u>Mystery Adventure Series</u></p> <p>Mystery Adventure Reader I Mystery Adventure Reader II Mystery Adventure of the Talking Statues Mystery Adventure of the Jeweled Ball Mystery Adventure of Cave Four Mystery Adventure of the Indian Burial Ground</p>
---	--	---	--

OPTION READING LABORATORIES

JUNIOR HIGH

<p><u>Skill Area: INDEPENDENT READERS</u></p>		
<p>OPTION I</p> <p><u>Teen-Age Tales*</u></p> <p>Teen-Age Tales, Book A Teen-Age Tales, Book B Teen-Age Tales, Book C</p> <p><u>Teen-Age Tales (1-6)*</u></p> <p>Teen-Age Tales, Book 1 Teen-Age Tales, Book 2 Teen-Age Tales, Book 3 Teen-Age Tales, Book 4 Teen-Age Tales, Book 5 Teen-Age Tales, Book 6</p>	<p>OPTION II</p> <p>(In addition to Option I items)</p> <p><u>Passetters in Personal Reading*</u></p> <p>The Fish Who Weren't Moon City Thief in the Basement Widdershins Unwilling Witch The Thousand Voices of Timothy Reese</p> <p><u>The Literature Sampler*</u></p>	<p>OPTION III</p> <p>(In addition to Option I & II items)</p> <p><u>Mystery Adventure Series con't.</u></p> <p>Mystery Adventure of Longcliff Inn Mystery Adventure of Smuggled Treasure</p> <p><u>Wildlife Adventure Series*</u></p> <p>Gatie the Alligator Sleeky the Otter Skipper the Dolphin Timmy the Mountain Lion Bounder the Jackrabbits Thor the Moose Ruff the Wolf Arctos the Grizzly</p>

OPTION READING LABORATORIES

JUNIOR HIGH

<u>Skill Area: LETTER AND NUMBER RECOGNITION</u>		
<p>OPTION I</p> <p><u>Flash-X Programs*</u></p> <p>Set X-3 Basic Accuracy-Numbers Set X-4 Basic Accuracy-Letters Set X-5 Sight Vocabulary Set X-6 Sight Vocabulary Set X-10 Sight Vocabulary</p>	<p>OPTION II</p> <p>(In addition to Option I items)</p>	<p>OPTION III</p> <p>(In addition to Option I & II items)</p> <p><u>T-Matic Filmstrips*</u></p> <p>Span of Perception PTF-3 Letter Recognition ROF-1</p>

OPTION READING LABORATORIES

JUNIOR HIGH

<p>Skill Area: <u>LISTENING SKILLS</u></p>	<p>OPTION I:</p>	<p>OPTION II (In addition to Option I items)</p>	<p>OPTION III (In addition to Option I & II items) <u>Listen and Think Series (Tapes)*</u> Listen and Think D Listen and Think E Listen and Think F Listen and Think G Listen and Think B Listen and Think I <u>Wollensak Teaching Tapes*</u> Word Attack Skills (Approx. 50 tapes)</p>
--	------------------	--	--

Skill Area: <u>PERCEPTUAL DEVELOPMENT</u>		
<p>OPTION I</p> <p><u>T-Matic Filmstrips*</u></p> <p>Span of Perception PTF-3 (20 Filmstrips)</p> <p>Letter Recognition ROF-1 (20 Filmstrips)</p> <p>Words and Phrases VCF-1 (20 Filmstrips)</p> <p>Words and Phrases VCF-2 (20 Filmstrips)</p> <p>Words and Phrases VCF-3 (20 Filmstrips)</p> <p>Words and Phrases VCF-4 (20 Filmstrips)</p> <p>Words and Phrases VCF-5 (20 Filmstrips)</p> <p>Words and Phrases VCF-6 (20 Filmstrips)</p>	<p>OPTION II</p> <p>(In addition to Option I items)</p> <p><u>Tachistoscope Filmstrips</u></p> <p>Set ABC Basic Accuracy Filmstrip Look and Write</p> <p>Set 22 Primary Supplementary</p> <p>Set 31 Intermediate Supplementary Advanced Accuracy</p> <p>EDL Sight Vocabulary* Set A Set E Set B Set F Set C Set V-789 Set D Set V-1011</p> <p><u>T-Matic Filmstrips*</u></p> <p>Remedial Reading Filmstrips RRF-1 (20 Filmstrips)</p> <p>Spelling Word List SDF-2 (30 Filmstrips)</p> <p>Spelling Word List SDF-3 (30 Filmstrips)</p> <p>Spelling Word List SDF-4 (30 Filmstrips)</p> <p>Spelling Principles (30 Filmstrips)</p>	<p>OPTION III</p> <p>(In addition to Option I & II items)</p> <p><u>Craig Reader Programs*</u></p> <p>Perception I, II, III (16 Lessons Each)</p> <p>C (30 Lessons)</p> <p>C-1 (32 Lessons)</p> <p>C-2 (30 Lessons)</p> <p>C-3 (30 Lessons)</p> <p>C-4 (35 Lessons)</p> <p>C-5 (40 Lessons)</p> <p>Reading Skills I</p> <p>Roots I/Roots II</p> <p><u>Tachistoscope Filmstrips</u></p> <p>Look at Words* Set A Set D Set B Set E Set C Set F</p>



OPTION READING LABORATORIES

JUNIOR HIGH

<p>Skill Area: <u>PHONICS</u></p>	<p><u>OPTION I</u></p> <p><u>Barnell-Loft Specific Skills</u></p> <p>Working with Sounds A Working with Sounds B Working with Sounds C Working with Sounds D</p> <p><u>Language Master Cards and Programs</u></p> <p>Blank Cards</p>	<p><u>OPTION II</u></p> <p>(In addition to Option I items)</p> <p><u>Language Master Cards and Programs</u></p> <p>Phonics Program -Sound Blending and Beginning Phonetic Skills Set I -Consonant Blends and Irregular Phonetic Sounds Set II -Word Building and Word Analysis Techniques</p> <p><u>Phonics We Use Series*</u></p> <p>Phonics We Use, Book A Phonics We Use, Book B Phonics We Use, Book C Phonics We Use, Book D Phonics We Use, Book E Phonics We Use, Book F Phonics We Use, Book G</p> <p>Dr. Spello</p>	<p><u>OPTION III</u></p> <p>(In addition to Option I & II items)</p> <p><u>First Experience with Vowels and Consonants</u></p> <p>Instructo - First Experience with Vowels and Consonants Phonics In A Nutshell* Phonics Is Fun, Book 1 Phonics Is Fun, Book 2 Phonics Is Fun, Book 3</p> <p><u>Ideal Listen-Look-Learn Reading Tapes and Worksheets</u></p> <p>Initial and Final Consonant (20 Lessons) Blends and Diagraphs (10 Lessons) Vowel Tapes (20 Lessons) Vowel Enrichment (20 Lessons) Syllable Rule - Accent Clues (16 Lessons)</p> <p><u>Merrill Refresher Program of Linguistic Readers*</u></p> <p>Book A - Cloth Book B - Cloth Book C - Cloth Book D - Cloth</p>
-----------------------------------	--	--	---

OPTION READING LABORATORIES

JUNIOR HIGH

<p>Skill Area: <u>PHONICS</u></p>	<p>OPTION I (See Preceding Page)</p>	<p>OPTION II (In addition to Option I items) (See Preceding Page)</p>	<p>OPTION III (In addition to Option I & II items) Conquests in Reading Readers Digest Skillbuilders <u>Spelling Word Power Laboratories*</u> Spelling Word Power Lab IIa Spelling Word Power Lab IIb Spelling Word Power Lab IIc Spelling Word Power Lab IIIa <u>Words In Color*</u> <u>Wollensak Teaching Tapes*</u> Introduction to the Listening Experience Sounds At Home Sounds We See Walking Sounds Word Attack Skills: Approx. 50 tapes on recognition and location of long and short vowels and consonants Syllables</p>
-----------------------------------	--	---	--

OPTION READING LABORATORIES

JUNIOR HIGH

Skill Area: <u>RATE</u>			
<p><u>OPTION I</u></p> <p><u>Better Reading Books</u></p> <p>Better Reading, Book 1 Better Reading, Book 2 Better Reading, Book 3</p> <p><u>Controlled Reader Filmstrips*</u></p> <p>CR-A (Two Albums) CR-B (Two Albums) CR-C (Two Albums) CR-D (One Album) CR-E (One Album) CR-F (One Album) CR-G1 (One Album)</p>	<p><u>OPTION II</u></p> <p>(In addition to Option I items)</p> <p><u>SRA Reading Laboratory*</u></p> <p>SRA Lab IIIa SRA Lab IIIb</p>	<p><u>OPTION III</u></p> <p>(In addition to Option I & II items)</p>	

JUNIOR HIGH

<p>Skill Area: <u>REFERENCE</u></p>	<p>OPTION I</p>	<p>OPTION II (In addition to Option I items) <u>Thorndike-Barnhart Advanced Junior Dictionary (4th Edition)*</u></p>	<p>OPTION III (In addition to Option I & II items) <u>Thesauri</u> In Other Words I A Beginning Thesaurus In Other Words II A Junior Thesaurus</p>
-------------------------------------	------------------------	---	---

OPTION READING LABORATORIES

JUNIOR HIGH

<p>Skill Area: <u>SPELLING</u></p>	<p><u>OPTION I</u></p> <p><u>Conquests in Reading</u></p> <p><u>Flash-X Programs*</u></p> <p>Set X-12 Spelling Level 2 Set X-13 Spelling Level 3 Set X-14 Spelling Level 4</p> <p><u>T-Matic Filmstrips</u></p> <p>Spelling Word List SDF-2 (30 Filmstrips) Spelling Word List SDF-3 (30 Filmstrips) Spelling Word List SDF-4 (30 Filmstrips) Spelling Principles (30 Filmstrips)</p>	<p><u>OPTION II</u></p> <p>(In addition to Option I items)</p> <p><u>Spelling Word Power Laboratories</u></p> <p>Spelling Word Power Lab IIa Spelling Word Power Lab IIb Spelling Word Power Lab IIc Spelling Word Power Lab IIIa</p> <p>Dr. Spello*</p>	<p><u>OPTION III</u></p> <p>(In addition to Option I & II items)</p>
------------------------------------	---	--	--

OPTION READING LABORATORIES

JUNIOR HIGH

Skill Area: STRUCTURAL ANALYSIS

OPTION I

OPTION II

(In addition to Option I items)

OPTION III

(In addition to Option I & II items)

Hoffman Reader Programs*

- Primary Achievement Units
(10 Albums per unit)
- 3rd Level Achievement Units
(10 Albums per unit)
- 4th Level Achievement Units
(10 Albums per unit)
- 5th Level Achievement Units
(10 Albums per unit)
- 6th Level Achievement Units
(10 Albums per unit)

Ideal Listen-Look-Learn Reading
Tapes and Workbooks*

- Initial and final Consonant
Tapes
- Blends and Diagraphs
Vowel Tapes
- Vowel Enrichment
Syllable Rulle - Accent Clues

Barnell-Loft Reading Series

Working with Sounds B through F

OPTION READING LABORATORIES

JUNIOR HIGH

Skill Area: <u>VOCABULARY</u>	OPTION I	OPTION II (In addition to Option I items)	OPTION III (In addition to Option I & II items)
<u>Language Master Cards and Programs*</u>	Blank Cards	<u>Be A Better Reader Series</u>	<u>Machillan Reading Spectrum</u>
<u>Reading for Concepts*</u>	Reading for Concepts A Reading for Concepts B Reading for Concepts C Reading for Concepts D Reading for Concepts E Reading for Concepts F Reading for Concepts G Reading for Concepts B	Be A Better Reader I Be A Better Reader II Be A Better Reader III Be A Better Reader IV Better Reading Book I Book II	Spectrum of Skills, Development Kit <u>Tachistoscope (Tach-X)</u>
<u>T-Matic Filmstrips</u>	Words and Phrases VCF-1 (20 Filmstrips) Words and Phrases VCF-2 (20 Filmstrips) Words and Phrases VCF-3 (20 Filmstrips) Words and Phrases VCF-4 (20 Filmstrips) Words and Phrases VCF-5 (20 Filmstrips)	<u>Language Master Cards and Programs*</u>	Looking at Words Series Set A Set D Set B Set E Set C Set F
		<u>Phonic Programs</u> -Sound Blending and Beginning Phonic Skills, Set I -Consonant Blends and Irregular Phonic Sounds, Set II -Word Building and Word Analysis Technique Word Picture Program Nouns and Everyday Things Verbs/Action Words Basic Concepts Building Basic English, A Building Basic English, B	

OPTION READING LABORATORIES

JUNIOR HIGH

Skill Area: <u>VOCABULARY</u>		
OPTION I (See Preceding Page)	OPTION II (In addition to Option I items) <u>New Practice Readers*</u> New Practice Readers, Book A New Practice Readers, Book B New Practice Readers, Book C New Practice Readers, Book D New Practice Readers, Book E New Practice Readers, Book F New Practice Readers, Book G <u>Pilot Library, IIa</u> <u>Pilot Library, IIb</u> <u>SRA Reading Laboratory*</u> SRA Lab IIIa SRA Lab IIIb <u>Tachistoscope (Tach-X)</u> EDL Sight Vocabulary Set A Set E Set B Set F Set C Set V-789 Set D Set V-1011	OPTION III (In addition to Option I & II items) (See Preceding Page)

OPTION READING LABORATORIES

SENIOR HIGH

<u>Skill Area: EQUIPMENT</u>		
<p>OPTION I</p> <p>(2) Controlled Reader, Jr. (2) Language Master (2) T-Matic 150 (1) Tape Recorder (1) Headset</p>	<p>OPTION II</p> <p>(3) Controlled Reader, Jr. (2) Language Master (2) T-Matic 150 (2) Tape Recorder (2) Headset (1) Overhead Projector (1) Tachistoscope (1) Interval Test Timer</p>	<p>OPTION III</p> <p>(3) Controlled Reader, Jr. (2) Language Master (2) T-Matic 150 (3) Tape Recorder (1) Headset (1) Overhead Projector (1) Tachistoscope (1) Interval Test Timer (1) Craig Reader (1) Hoffman Reader</p>

Skill Area: <u>COMPREHENSION</u>	OPTION I	OPTION II (In addition to Option I items)	OPTION III (In addition to Option I & II items)
	<p><u>Barnell-Loft Specific Skill Series</u></p> <p>Drawing Conclusions A Drawing Conclusions B Drawing Conclusions C Drawing Conclusions D Drawing Conclusions E</p> <p>Following Directions A Following Directions B Following Directions C Following Directions D Following Directions E Following Directions F</p> <p>Getting the Facts A Getting the Facts B Getting the Facts C Getting the Facts D Getting the Facts E Getting the Facts F</p> <p>Getting the Main Idea A Getting the Main Idea B Getting the Main Idea C Getting the Main Idea D Getting the Main Idea E</p>	<p><u>Better Reading Books</u></p> <p>Better Reading, Book 1 Better Reading, Book 2 Better Reading, Book 3</p> <p><u>Be A Better Reader</u></p> <p>Be A Better Reader A Be A Better Reader B Be A Better Reader C Be A Better Reader I Be A Better Reader II Be A Better Reader III Be A Better Reader IV</p> <p><u>Comprehension Power Series</u></p> <p>Controlled Reader, Set C-3 Controlled Reader, Set C-4 Controlled Reader, Set C-5 Controlled Reader, C-6</p> <p><u>Merrill Refresher Course</u></p> <p>Reader A Reader B Reader C Reader D</p>	<p><u>Craig Reader Programs</u></p> <p>C C-3 C-1 C-4 C-2 C-5</p> <p><u>Hoffman Reader Programs</u></p> <p>Primary Achievement Unit 3rd Level Achievement Unit 4th Level Achievement Unit 5th Level Achievement Unit 6th Level Achievement Unit</p> <p><u>Mott Basic Language Skills Program*</u></p> <p>Basic Language Skills, Book 1307 Basic Language Skills, Book 1308 Basic Language Skills, Book 1309 Basic Language Skills, Book 1310</p> <p><u>New Modern Reading Skilltexts*</u></p> <p>New Modern Reading Skilltexts, Book 1 New Modern Reading Skilltexts, Book 2</p>

OPTION READING LABORATORIES

SENIOR HIGH

<p><u>Skill Area: COMPREHENSION</u></p>			
<p><u>OPTION I</u></p> <p><u>Barnell-Loft Specific Skill Series</u> con't.</p> <p>Locating the Answer A Locating the Answer B Locating the Answer C Locating the Answer D Locating the Answer E Locating the Answer F</p> <p>Using the Context A Using the Context B Using the Context C Using the Context D Using the Context E Using the Context F</p> <p><u>Controlled Reader Filmstrips</u></p> <p>Controlled Reader, Set C-7-8 Controlled Reader, Set CR-AA Controlled Reader, Set CR-BA Controlled Reader, Set CR-CA Controlled Reader, Set CR-DA Controlled Reader, Set CR-EA Controlled Reader, Set CR-FA</p>	<p><u>OPTION II</u> (In addition to Option I items)</p> <p><u>Merrill Mainstream</u></p> <p>Against the Odds City Beneath the Sea Courage Under Fire In New Directions People Like You The Search for Piranha They Were First Sacred Well of Sacrifice Viking Treasure</p> <p><u>New Practice Readers*</u></p> <p>New Practice Readers, Book C New Practice Readers, Book D New Practice Readers, Book E New Practice Readers, Book F New Practice Readers, Book G</p> <p><u>Reading for Meaning Series</u></p> <p>Reading for Meaning, 4 Reading for Meaning, 5 Reading for Meaning, 6 Reading for Meaning, 7 Reading for Meaning, 8 Reading for Meaning, 9</p>	<p><u>OPTION III</u> (In addition to Option I & II items)</p> <p><u>New Modern Reading Skilltexts*</u> con't</p> <p>New Modern Reading Skilltexts, Book 3</p> <p><u>Stories for Teen-Agers*</u></p> <p>Stories for Teen-Agers, Book A, Red Stories for Teen-Agers, Book B, Blue Stories for Teen-Agers, Book C, Yellow Stories for Teen-Agers, Book D, Green</p>	

OPTION READING LABORATORIES

SENIOR HIGH

<p>Skill Area: <u>COMPREHENSION</u></p>	<p><u>OPTION I</u></p> <p><u>Reading for Concepts</u></p> <p>Reading for Concepts A Reading for Concepts B Reading for Concepts C Reading for Concepts D Reading for Concepts E Reading for Concepts F Reading for Concepts G Reading for Concepts H</p>	<p><u>OPTION II</u></p> <p>(In addition to Option I items)</p> <p><u>Reading for Understanding Series</u></p> <p>Reading for Understanding, General Edition</p> <p><u>SRA Pilot Libraries*</u></p> <p>Pilot Library IIc Pilot Library IIIb</p> <p><u>SRA Reading Laboratories*</u></p> <p>SRA Lab IIIb</p> <p><u>Turner-Livingston Communication Series</u></p> <p>The Language You Speak The Letter You Write The Movies You See The Newspaper You Read The Phone Calls You Make The Television You Watch</p>	<p><u>OPTION III</u></p> <p>(In addition to Option I & II items)</p> <p>(See Preceding Page)</p>
---	--	--	--

<p>Skill Area: <u>GENERAL</u></p>	<p><u>OPTION I</u></p> <p><u>Kaleidoscope of Skills*</u></p> <p>Book 5-1 Red/Silver Book 5-2 Gold Book 5-3 Lavender Book 5-4 Olive Book 6-1 Orange/Agua Book 6-2 Tan Book 6-3 Purple Book 6-4 Lime Book 7-1 Rust/Blue Book 7-2 Yellow Book 7-3 Green</p> <p>Reading Attainment I:*</p>	<p><u>OPTION II</u></p> <p>(In addition to Option I items)</p> <p><u>Adult Readers (Readers Digest)*</u></p> <p>A Race To Remember First at the Finish Guides to High Adventure "I Fell 18,000 Feet" Men Who Dare the Sea Mystery of the Mountains Sante Fe Traders Second Change "Send for Red" Valley of 10,000 Smokes What's on the Moon? Workers in the Sky</p> <p>Dr. Spello</p> <p><u>Gateway Series, Level Three</u> <u>Anthologies</u></p> <p>Rebels and Regulars People in Poetry Something Strange Ways of Justice</p> <p><u>Manpower and Natural Resources Kit*</u></p>	<p><u>OPTION III</u></p> <p>(In addition to Option I & II items)</p> <p><u>Gates-Pearson Reading Exercises</u></p> <p>Intermediate SA, FD, RD Advanced SA, FD, RD</p> <p><u>McCall-Crabbe Series*</u></p> <p>McCall-Crabbe, Book E McCall-Crabbe, Book D McCall-Crabbe, Book E</p> <p><u>New Modern Reading Skilltexts*</u></p> <p>New Modern Reading Skilltexts, Book 1 New Modern Reading Skilltexts, Book 2 New Modern Reading Skilltexts, Book 3</p> <p><u>Reader's Digest: New Reading Skill Builders</u></p> <p>Level 4 Part I Part II</p>
-----------------------------------	--	--	--

OPTION READING LABORATORIES

SENIOR HIGH

<p>Skill Area: <u>GENERAL</u></p>	<p><u>OPTION I</u> (See Preceding Page)</p>	<p><u>OPTION II</u> (In addition to Option I items)</p> <p><u>Reader's Digest Practice Pads*</u> Practice Pad 2 Practice Pad 3</p> <p><u>Advanced Reading Skill Builders*</u> Level 7 Book One Book Two Level 8 Book Three Book Four</p> <p><u>SRA Reading Laboratory*</u> SRA Lab, IIIb</p> <p><u>Merrill Refresher Course</u> Reader A Reader C Reader B Reader D</p>	<p><u>OPTION III</u> (In addition to Option I & II items)</p> <p><u>Reader's Digest New Reading Skill Builders con't.</u> Level 5 Part I Part II Level 6 Part I Part II</p> <p><u>Sullivan Programmed Reading*</u> Books 1-21</p> <p><u>Webster Reading Clinic 10X*</u> New Webster Word Wheels</p>
-----------------------------------	---	---	---

OPTION READING LABORATORIES

SENIOR HIGH

<p>Skill Area: <u>HANDWRITING</u></p>	<p>OPTION I</p>	<p>OPTION II (In addition to Option I items)</p>	<p>OPTION III (In addition to Option I & II items) <u>Peterson Handwriting Series*</u> Improve Your Writing For Job Success, Basic Text (Sr. High) Handwriting Legibility Kit for Young Adults (Learner)</p>
---------------------------------------	-----------------	--	--

OPTION READING LABORATORIES

SENIOR HIGH

Skill Area: <u>INDEPENDENT READERS</u>			
<p><u>OPTION I</u></p> <p><u>Bowmar Reading Incentive Program*</u></p> <p>Karting The Mighty Midgets Slot Car Racing Motorcycles Drag Racing Teen Fair Horses Surfing Drag Racing - Funny Cars Dune Buggies Duo Buggy Racing Custom Cars</p> <p><u>Bowmar Reading Incentive Program</u></p> <p>Multi-Media Kit</p> <p><u>On Target (Reading for Pleasure Series)*</u></p> <p>On Target Top Flight In Orbit</p>	<p><u>OPTION II</u></p> <p>(In addition to Option I items)</p> <p><u>Merrill Mainstream*</u></p> <p>Courage Under Fire Against the Odds They Were First In New Directions People Like You</p> <p><u>Checkered Flag Learning System*</u></p> <p>Classroom Kit A Wheels Riddler Bearcat Smashup Classroom Kit B Scramble Flea Grand Prix S00</p> <p><u>Checkered Flag Learning System*</u></p> <p>Audio-Visual Kit A Audio-Visual Kit B</p>	<p><u>OPTION III</u></p> <p>(In addition to Option I & II items)</p> <p><u>Deep Sea Adventure Series*</u></p> <p>The Sea Hunt Treasure Under the Sea Submarine Rescue The Pearl Divers Frogmen in Action Danger Below Whale Hunt Rocket Divers</p> <p><u>Morgan Bay Mystery Series*</u></p> <p>Mystery of Morgan Castle Mystery of the Marble Angel Mystery of the Midnight Visitor Mystery of the Musical Ghost Mystery of the Missing Marlin Mystery of Monk's Island Mystery of Marauder's Gold Mystery of the Myrmaidon's Journey</p> <p><u>Mystery Adventure Series*</u></p> <p>Mystery Adventure Reader I Mystery Adventure Reader II</p>	

<p><u>Skill Area: INDEPENDENT READERS</u></p>			
<p>OPTION I (See Preceding Page)</p>	<p>OPTION III (In addition to Option I & II items) <u>Mystery Adventure Series* cont.</u> Mystery Adventure of the Talking Statues Mystery Adventure of the Jeweled Ball Mystery Adventure of Cave Four Mystery Adventure of the Indian Burial Ground Mystery Adventure of Longcliff Inn Mystery Adventure of Smuggled Treasure <u>Teen-Age Tales*</u> Teen-Age Tales, Book A Teen-Age Tales, Book B Teen-Age Tales, Book C <u>Teen-Age Tales*</u> Teen-Age Tales, Book 1 Teen-Age Tales, Book 2 Teen-Age Tales, Book 3 Teen-Age Tales, Book 4 Teen-Age Tales, Book 5 Teen-Age Tales, Book 6</p>	<p>OPTION II (In addition to Option I items) <u>Sullivan Storybooks, Classroom Library Set*</u> Sullivan Storybook, Classroom Library Set <u>The Literature Sampler*</u></p>	

OPTION READING LABORATORIES

SENIOR HIGH

<p>Skill Area: <u>INDEPENDENT READERS</u></p>	<p>OPTION I (See Preceding Page)</p>	<p>OPTION II (In addition to Option I items) (See Preceding Page)</p>	<p>OPTION III (In addition to Option I & II items) <u>"What Job for 'B" Series"</u> Charley the TV Repairman John the Second Best Cook in Town Pete the Service Station Attendant Nick the Waiter Joe the Retail Salesman Judy the Waitress Frank the Vending Machine Repairman Betty and Her Typewriter Gunny the Office Assistant Carman the Beautician Cool It, Man: Tom the Merchant Seaman Phil the File Clerk Tim the Draftsman Keep It Clean Sandy the Lineman Burt the Policeman Ned the Taxicab Driver</p>
---	--	---	---

OPTION READING LABORATORIES

SENIOR HIGH

<u>Skill Area: LISTENING SKILLS</u>		
<p>OPTION I</p>	<p>OPTION II (In addition to Option I items)</p>	<p>OPTION III (In addition to Option I & II items) <u>Listen and Think Series (Tapes)</u> Listen and Think D Listen and Think E Listen and Think F Listen and Think G Listen and Think H Listen and Think I</p>

OPTION READING LABORATORIES

SENIOR HIGH

Skill Area: <u>PHONICS</u>	OPTION I	OPTION II (In addition to Option I items)	OPTION III (In addition to Option I & II items)
<u>Barnell-Loft Specific Skills*</u>	Working with Sounds A Working with Sounds B Working with Sounds C Working with Sounds D	<u>Language Master Cards and Programs</u>	Phonics In A Nutshell
	Blank Cards Phonics Program	-Sound Blending and Beginning Phonetic Skills Set I -Consonant Blends and Irregular Phonetic Sounds Set II -Word Building and Word Analysis Techniques	<u>Language Master Cards and Programs</u>
		<u>Merrill Refresher Program of Linguistic Readers*</u>	Word Picture Program Nouns and Everyday Things Verbs/Action Words Basic Concepts
		Book A-Cloth Book B-Cloth Book C-Cloth Book D-Cloth	Building Basic English A Building Basic English B
		<u>Phonics We Use Series*</u>	<u>Spelling Word Power Laboratories*</u>
		Phonics We Use, Book D Phonics We Use, Book E Phonics We Use, Book F Phonics We Use, Book G	Spelling Word Power Lab IIC Spelling Word Power Lab IIIa
			<u>Words In Color*</u>
			<u>Wollensak Teaching Tapes*</u>
			Syllables



OPTION READING LABORATORIES

SENIOR HIGH

<p>Skill Area: <u>PHONICS</u></p>	<p>OPTION I (See Preceding Page)</p>	<p>OPTION II (In addition to Option I items) <u>Spelling Word Power Laboratories*</u> Spelling Word Power Lab IIa Spelling Word Power Lab IIb</p>	<p>OPTION III (In addition to Option I & II items) (See Preceding Page)</p>
-----------------------------------	--	---	---

OPTION READING LABORATORIES

SENIOR HIGH

Skill Area: <u>RATE</u>		
<p>OPTION I</p> <p><u>Controlled Reader Filmstrips</u></p> <p>Controlled Reader Set CR-AA Controlled Reader Set CR-BA Controlled Reader Set CR-CA Controlled Reader Set CR-DA Controlled Reader Set CR-EA Controlled Reader Set CR-FA</p>		
	<p>OPTION II</p> <p>(In addition to Option I items)</p> <p><u>Better Reading Books</u></p> <p>Better Reading, Book 1 Better Reading, Book 2</p> <p><u>SRA Reading Laboratory*</u></p> <p>SRA Lab IIIb</p>	
		<p>OPTION III</p> <p>(In addition to Option I & II items)</p>

OPTION READING LABORATORIES

SENIOR HIGH

<p>Skill Area: <u>REFERENCE</u></p>	<p>OPTION I <u>Thorndike-Barnhart Advanced Junior Dictionary (4th Edition)*</u></p>	<p>OPTION II (In addition to Option I items)</p>	<p>OPTION III (In addition to Option I & II items)</p>
-------------------------------------	---	--	--

OPTION READING LABORATORIES

SENIOR HIGH

<p>Skill Area: <u>SPELLING</u></p>	<p>OPTION I</p> <p>Dr. Spello*</p>	<p>OPTION II (In addition to Option I items)</p> <p><u>Flash-X Programs*</u></p> <p>Set X-12 Spelling Level 2 Set X-13 Spelling Level 3 Set X-14 Spelling Level 4</p> <p><u>Spelling Word Power Laboratories*</u></p> <p>Spelling Word Power Lab IIA Spelling Word Power Lab IIB</p> <p><u>T-Matic Filmstrips*</u></p> <p>Spelling Word List SDF-2 (30 Filmstrips) Spelling Word List SDF-3 (30 Filmstrips) Spelling Word List SDF-4 (30 Filmstrips) Spelling Principles (30 Principles)</p>	<p>OPTION III (In addition to Option I & II items)</p> <p><u>Spelling Word Power Laboratories*</u></p> <p>Spelling Word Power Lab IIC Spelling Word Power Lab IIIA</p>
------------------------------------	------------------------------------	--	--

<u>Skill Area: STRUCTURAL ANALYSIS</u>		
<p>OPTION I</p>	<p>OPTION II (In addition to Option I items)</p>	<p>OPTION III (In addition to Option I & II items)</p> <p><u>Hoffman Reader Programs*</u></p> <p>Primary Achievement Unit (10 Albums per unit) 3rd Level Achievement Unit (10 Albums per unit) 4th Level Achievement Unit (10 Albums per unit) 5th Level Achievement Unit (10 Albums per unit) 6th Level Achievement Unit (10 Albums per unit)</p>

<p>Skill Area: <u>STUDY SKILLS</u></p>	<p>OPTION I</p>	<p>OPTION II (In addition to Option I items)</p>	<p>OPTION III (In addition to Option I & II items)</p> <p><u>Reading for Meaning Series*</u></p> <p>Reading for Meaning, 4 Reading for Meaning, 5 Reading for Meaning, 6 Reading for Meaning, 7 Reading for Meaning, 8 Reading for Meaning, 9</p> <p>How to Study*</p>
--	-----------------	--	--

OPTION READING LABORATORIES

SENIOR HIGH

Skill Area: <u>VOCABULARY</u>	OPTION I <u>Language Master Cards and Programs</u> Blank Cards <u>Reading for Concepts*</u> Reading for Concepts A Reading for Concepts B Reading for Concepts C Reading for Concepts D Reading for Concepts E Reading for Concepts F Reading for Concepts G Reading for Concepts H <u>SRA Reading Laboratory, Independent Readers*</u> SRA Lab IIIb <u>T-Matic Filmstrips*</u> Words and Phrases VCF-1 (20 Filmstrips) Words and Phrases VCF-2 (20 Filmstrips) Words and Phrases VCF-3 (20 Filmstrips)	OPTION II <u>(In addition to Option I items)</u> <u>Be A Better Reader Series*</u> Be A Better Reader, Book A Be A Better Reader, Book B Be A Better Reader, Book C <u>Language Master Cards and Programs</u> Phonic Programs -Sound Blending and Beginning Phonetic Skills, Set I -Consonant Blends and Irregular Phonic Sounds, Set II -Word Building and Word Analysis Technique Word Picture Program Nouns and Everyday Things Verbs/Action Words Basic Concepts Building Basic English A Building Basic English B <u>New Practice Readers*</u> New Practice Readers, Book A New Practice Readers, Book B New Practice Readers, Book C	OPTION III <u>(In addition to Option I & II items)</u> <u>Be A Better Reader Series*</u> Be A Better Reader I Be A Better Reader II Be A Better Reader III Be A Better Reader IV <u>Craig Reader Programs</u> C C-3 C-1 C-4 C-2 C-5 <u>Mott Basic Language Skills Program*</u> Basic Language Skills, Book 1307 Basic Language Skills, Book 1308 Basic Language Skills, Book 1310 Word Bank <u>EDL Word Clues Series*</u> EDL Word Clues, Book G EDL Word Clues, Book H EDL Word Clues, Book I EDL Word Clues, Book J EDL Word Clues, Book K EDL Word Clues, Book L
-------------------------------	---	--	---

OPTICON READING LABORATORIES

SENIOR HIGH

<p>Skill Area: <u>VOCABULARY</u></p>	<p><u>OPTION I</u></p> <p><u>T-Matic Filmstrips* con't</u></p> <p>Words and Phrases VCF-4 (20 Filmstrips) Words and Phrases VCF-5 (20 Filmstrips) Words and Phrases VCF-6 (20 Filmstrips) Words and Phrases VCF-7 (20 Filmstrips) Remedial Reading Filmstrips RRF-1 (20 Filmstrips)</p>	<p><u>OPTION II</u></p> <p>(in addition to Option I items)</p> <p><u>New Practice Readers* con't</u></p> <p>New Practice Readers, Book D New Practice Readers, Book E New Practice Readers, Book F New Practice Readers, Book G</p> <p><u>Pilot Library, IIC*</u> <u>Pilot Library, IIIB</u></p>	<p><u>OPTION III</u></p> <p>(In addition to Option I & II items)</p> <p><u>Tachistoscope (Tapes)</u></p> <p>EDL Sight Vocabulary Set A Set B Set B Set F Set C Set V-789 Set D Set V-1011</p> <p><u>Conquests in Reading*</u></p> <p>New Webster Word Wheels</p>
--------------------------------------	---	--	--

RECOMMENDED AND APPROVED MATERIALS AND EQUIPMENT

FOR THE

ELEMENTARY READING LABORATORY

RECOMMENDED

Materials

Barnell-Loft Specific Skill Series
Decoding for Reading
Detect Tactile
Dolch Readers
McCall-Crabbe Series
Michigan Language Program
Michigan Tracking Program
New Practice Readers
New Reading Skill Builders
Practice Pads
Reading for Concepts
Reading for Understanding
Spelling Word Power Laboratories
Study-Scopes Reading Program
Sullivan Programmed Reading
The Time Machine Series
Thesauri
TRY Experiences for Young Children

Materials Accompanying Equipment

Controlled Reader Filmstrips
Language Master Cards
Listen and Think Series
Tachistoscope Filmstrips
T-Matic Filmstrips

Equipment

Controlled Reader, Jr.
Filmstrip Projector
Language Master
Overhead Projector
Tachistoscope
Tachimatic 500 Projector
T-Matic 150 Projector

APPROVED

Materials

Building Reading Skill Series
Checkered Flag Learning System
Conquests in Reading
Deep Sea Adventure Series
Dr. Spello
Eye and Ear Fun
Frostig Development Program
Gates-Pearson Reading Exercises
Instructo First Experiences with
Vowels and Consonants
Jim Forest Readers
Learning to Read While Learning
to Learn
Learning to Think Series
Let's See - Eye and Ear Fun
Merrill Linguistic Readers

Materials Accompanying Equipment

Craig Reader Materials
Comprehension Power Series
Detect Visual Program
Flannel Board Letters
Flash-X Programs
Hoffman Reader Programs
Ideal Listen-Look-Learn Reading
Tapes
Perception Filmstrips
Phonics in a Nutshell
Sight and Sound of Phonics
System 80 Programs
Teaching Typewriter Programs
Tachomatic Words and Phrase
Filmstrips
Wollensak Teaching Tapes

APPROVED ELEMENTARY READING LABORATORY cont

Materials

Miami Linguistic Readers
Morgan Bay Mystery Series
Motivation Readers
Pacesetters in Personal Reading
Peabody Language Development Kits
Phonetic Reading Series
Phonetic Reading Series
Phonics is Fun
Phonics We Use Series
Phonics with Write and See
Pilot Library IIa
Pilot Library IIb
Primary Phonics
Royal Road Miniature Readers
Shapes Around Us Series
Singer Structural Series
Stories for First Phonics
Sullivan Storybook Classroom
Library Set
Tangrams
Time for Sounds
Universal Workbooks in Phonics
Webster Reading Clinic
We Read More Stories
Winter Haven Lions Program
Words in Color

Equipment

Craig Reader
Flannel Board
Flash-X Hand Tach
Headsets
Hoffman Reader
Interval Test Timer
School Skill Tracing Board
Stop Watch
System 80
Teaching Typewriter
Tok-Back

RECOMMENDED AND APPROVED MATERIALS AND EQUIPMENT

FOR THE

SECONDARY READING LABORATORY

RECOMMENDED

Materials

Adult Readers (Reader's Digest)
Barnell-Loft Specific Skill Series
Be A Better Reader Series
Bowmar Reading Incentive Program
Checkered Flag Learning System
Dimensions in Reading:
 An American Album
How to Study
MacMillan Reading Spectrum
McCall-Crabbe Series
Manpower and Natural Resources Kit
New Practice Readers
New Reading Skill Builders
On Target
Pilot Library IIC
Pilot Library IIIB
Practice Pads
Reading Attainment Series
Reading Development Kits
Reading for Concepts
Reading for Meaning Series
Reading for Understanding
Spelling Word Power Laboratories
SRA Reading Laboratory
Stories for Teen-Agers
Teen-Age Tales
The Literature Sampler
Thorndike-Barnhart Advanced Junior
 Dictionary

Materials Accompanying Equipment

Controlled Reader Filmstrips
Language Master Programs
Listen and Think Series
Reading Incentive Program (Bowmar)
Sight and Sound of Phonics
Tachistoscope Filmstrips
T-Matic Filmstrips

Equipment

Controlled Reader, Jr.
Controlled Reader, Large
Filmstrip Projector
Headsets
Interval Test Timer
Language Master
Overhead Projector Tachistoscope
Stop Watch
Tachomatic 500 Projector
Tape Recorder
T-Matic 150 Projector

APPROVED

Materials

Better Reading Books
Conquests in Reading
Decoding for Reading
Deep Sea Adventure Series

Materials Accompanying Equipment

Comprehension Power Series
Craig Reader Materials
Flash-X Programs
Phonics in a Nutshell

APPROVED SECONDARY READING LABORATORY con't

Materials

Dr. Spello
EDL Word Clues
Gates-Pearson Reading Exercises
Gateway Series, Level Three
Anthologies
Kaleidoscope of Skills
Learning to Read While Learning
to Learn
Merrill Mainstream
Merrill Refresher Program of
Linguistic Readers
Morgan Bay Mystery Series
Mott Basic Language Skills
Program
Mystery Adventure Series
New Modern Reading Skilltexts
Peterson Handwriting
Pilot Library IIa
Pilot Library IIb
Sullivan Programmed Reading
Thesauri
Turner-Livingston Communication
Series
Universal Workbooks in Phonics
"What Job for Me?" Series
Wildlife Adventure Series
Words in Color
World of Adventure Series

Materials Accompanying Equipment

Sight and Sound of Phonics
Tachomatic Words and Phrases Filmstrips

Equipment

Craig Reader
Flash-X Hand Tachistoscope
Portascribe

SKILL AREA - TITLES	INTEREST LEVELS											INSTRUCTIONAL LEVELS											DES- CRPTION PAGE NO.
	K-R	1-2	3-4	5-6	7-8	9-12	K	R	P	1	2	3	4	5	6	7	8	9	10	11	12		
AUDITORY DISCRIMINATION																							
Eye and Ear Fun, Book 1	x	x	x																			150	
Eye and Ear Fun, Book 2	x	x	x																			150	
Eye and Ear Fun, Book 3	x	x	x																			150	
Eye and Ear Fun, Book 4	x	x	x																			150	
Let's See	x	x	x																			150	
Michigan Language Program																						155	
Time for Sounds, Kit A	x	x	x																			191	
Time for Sounds, Kit B	x	x	x																			191	
Tok-Back	x	x	x																			193	
COMPREHENSION																							
Barnell-Loft Specific Skill Series																							
Drawing Conclusions A																						123	
Drawing Conclusions B																						123	
Drawing Conclusions C																						123	
Drawing Conclusions D																						123	
Drawing Conclusions E																						123	
Following Directions A																						122	
Following Directions B																						122	
Following Directions C																						122	
Following Directions D																						122	
Following Directions E																						122	
Following Directions F																						122	
Getting the Facts A																						120	
Getting the Facts B																						120	
Getting the Facts C																						120	
Getting the Facts D																						120	
Getting the Facts E																						120	
Getting the Facts F																						120	

SKILL AREA COMPREHENSION

<u>SKILL AREA - TITLES</u>	<u>INTEREST LEVELS</u>												<u>INSTRUCTIONAL LEVELS</u>										<u>DES-CRIPTION</u> <u>PAGE NO.</u>						
	<u>1-2</u>		<u>3-4</u>		<u>5-6</u>		<u>7-8</u>		<u>9-12</u>			<u>K</u>	<u>R</u>	<u>P</u>	<u>1</u>	<u>2</u>	<u>3</u>	<u>4</u>	<u>5</u>	<u>6</u>	<u>7</u>	<u>8</u>	<u>9</u>	<u>10</u>	<u>11</u>	<u>12</u>			
<u>Barnell-Loft Specific Skill Series con't.</u>																													
Getting the Main Idea A	x	x	x	x	x	x	x	x	x	x																		123	
Getting the Main Idea B	x	x	x	x	x	x	x	x	x	x																			123
Getting the Main Idea C																			x									123	
Getting the Main Idea D																			x									123	
Getting the Main Idea E																			x									123	
Locating the Answer A	x	x	x	x	x	x	x	x	x	x																		122	
Locating the Answer B	x	x	x	x	x	x	x	x	x	x																		122	
Locating the Answer C																			x									122	
Locating the Answer D																			x									122	
Locating the Answer E																			x									122	
Locating the Answer F																			x									122	
Using the Context A	x	x	x	x	x	x	x	x	x	x																		121	
Using the Context B	x	x	x	x	x	x	x	x	x	x																		121	
Using the Context C																			x									121	
Using the Context D																			x									121	
Using the Context E																			x									121	
Using the Context F																			x									121	
<u>Better Reading Books</u>																													
Better Reading, Book 1																													125
Better Reading, Book 2																			x										125
Better Reading, Book 3																			x										125
<u>Comprehension Power Series</u>																													
Controlled Reader, Set C-3																													129
Controlled Reader, Set C-4																													129
Controlled Reader, Set C-5																													129
Controlled Reader, Set C-6																													129

SKILL AREA COMPREHENSION

SKILL AREA - TITLES	INTEREST LEVELS										INSTRUCTIONAL LEVELS										DES- CRPTION PAGE NO.				
	K-1	K-2	3-4	5-6	7-8	9-1	K	R	P	1	2	3	4	5	6	7	8	9	10	11		12			
<u>Controlled Reader Filmstrips</u>																									
CR-MT: Motility Training																									130
CR-AD: Accelerated Discrimination																									130
CR-A (Two Albums)																									130
CR-B (Two Albums)																									130
CR-C (Two Albums)																									130
CR-D (One Album)																									130
CR-DD (One Album)																									130
CR-E (One Album)																									130
CR-EE (One Album)																									130
CR-F (One Album)																									130
CR-FF (One Album)																									130
CR-GH (One Album)																									130
CR-HS (One Album)																									130
CR-IJ (One Album)																									130
CR-JI (One Album)																									130
Controlled Reader, Set C-7-8																									129
Controlled Reader Set CR-AA																									129
Controlled Reader Set CR-BA																									129
Controlled Reader Set CR-CA																									129
Controlled Reader Set CR-DA																									129
Controlled Reader Set CR-EA																									129
Controlled Reader Set CR-FA																									129
<u>Craig Reader Programs</u>																									131
C (30 lessons)																									131
C-1 (32 lessons)																									131
C-2 (30 lessons)																									131
C-3 (30 lessons)																									131
C-4 (35 lessons)																									131
C-5 (40 lessons)																									131

<u>SKILL AREA - TITLES</u>	<u>INTEREST LEVELS</u>												<u>INSTRUCTIONAL LEVELS</u>												<u>DESCRIPTION PAGE NO.</u>
	<u>K-R</u>	<u>1-2</u>	<u>3-4</u>	<u>5-6</u>	<u>7-8</u>	<u>9-12</u>	<u>K</u>	<u>R</u>	<u>P</u>	<u>1</u>	<u>2</u>	<u>3</u>	<u>4</u>	<u>5</u>	<u>6</u>	<u>7</u>	<u>8</u>	<u>9</u>	<u>10</u>	<u>11</u>	<u>12</u>				
Reading Skills I						x																	131		
Roots I/Roots II						x																	151		
Reading Program A						x																	131		
Reading Program B						x																	131		
<u>Deep Sea Adventure Series</u>																							132		
Danger Below						x																	132		
Frogmen in Action						x																	132		
Rocket Divers						x																	132		
Submarine Rescue						x																	132		
Treasure Under the Sea						x																	132		
The Pearl Divers						x																	132		
The Sea Hunt						x																	132		
Whale Hunt						x																	132		
<u>Dimensions in Reading-An American Album</u>						x																	134		
<u>Hoffman Reader Programs</u>																							142		
Primary Achievement Units																							142		
3rd Level Achievement Units						x																	142		
4th Level Achievement Units						x																	142		
5th Level Achievement Units						x																	142		
6th Level Achievement Units						x																	142		
<u>Ideal Listen-Look-Learn Reading Tapes</u>																							144		
Reading Readiness Tapes																							144		
Classification-Opposites Sequence Tapes																							144		

SKILL AREA COMPREHENSION

SKILL AREA - TITLES	INTEREST LEVELS												INSTRUCTIONAL LEVELS												DES- CRPTION PAGE NO.
	K-R	1-2	3-4	5-6	7-8	9-12	K	R	P	1	2	3	4	5	6	7	8	9	10	11	12				
<u>MacMillan Reading Spectrum</u>																							152		
Spectrum of Skills Development Kit																							152		
Spectrum of Skills (Independent Readers)																							152		
<u>Merrill Linguistic Readers</u>																							153		
Linguistic Reader 1																							153		
Linguistic Reader 2																							153		
Linguistic Reader 3																							153		
Linguistic Reader 4																							153		
Linguistic Reader 5																							153		
Linguistic Reader 6																							153		
<u>Merrill Mainstream</u>																							154		
Against the Odds																							154		
City Beneath the Sea																							154		
Courage Under Fire																							154		
In New Directions																							154		
People Like You																							154		
The Search for Piranha																							154		
They Were First																							154		
Sacred Well of Sacrifice																							154		
Viking Treasure																							154		
<u>Morgan Bay Mystery Series</u>																							156		
Mystery of Marauder's Gold																							156		
Mystery of Monk's Island																							156		
Mystery of Morgan Castle																							156		
Mystery of the Marble Angel																							156		
Mystery of the Midnight Visitor																							156		
Mystery of the Missing Marlin																							156		
Mystery of the Musical Ghost																							156		
Mystery of the Myrmaidon's Journey																							156		

<u>SKILL AREA - TITLES</u>	<u>INTEREST LEVELS</u> K-R 1-2 3-4 5-6 7-8 9-12	<u>INSTRUCTIONAL LEVELS</u> K R P 1 2 3 4 5 6 7 8 9 10 11 12	<u>DESCRIPTION PAGE NO.</u>
<u>Mott Basic Language Skills Program</u>			
Basic Language Skills, Book 1307	x	x x x	157
Basic Language Skills, Book 1308	x	x x x	157
Basic Language Skills, Book 1309	x	x x x	157
Basic Language Skills, Book 1310	x	x x x	157
<u>New Modern Reading Skilltexts</u>			
New Modern Reading Skilltexts, Book 1	x	x x x	159
New Modern Reading Skilltexts, Book 2	x	x x x	159
New Modern Reading Skilltexts, Book 3	x	x x x	159
<u>New Practice Readers</u>			
New Practice Readers, Book A	x	x	159
New Practice Readers, Book B	x	x	159
New Practice Readers, Book C	x	x	159
New Practice Readers, Book D	x	x	159
New Practice Readers, Book E	x	x	159
New Practice Readers, Book F	x	x	159
New Practice Readers, Book G	x	x	159
<u>Reading Development Kits</u>			
Kit A	x	x x x	174
Kit B	x	x x x	174
Kit C	x	x x x x	174
<u>Reading for Concepts (A-H)</u>			
Reading for Concepts (A)	x	x	173
Reading for Concepts (B)	x	x	173
Reading for Concepts (C)	x	x	173
Reading for Concepts (D)	x	x	173

SKILL AREA - TITLES	INTEREST LEVELS K-R 1-2 3-4 5-6 7-8 9-12	INSTRUCTIONAL LEVELS K R P 1 2 3 4 5 6 7 8 9 10 11 12	DES- CRPTION PAGE NO.
Reading for Concepts (A-H) con't.			
Reading for Concepts E	x	x	173
Reading for Concepts F	x	x	173
Reading for Concepts G	x	x	173
Reading for Concepts H	x	x	173
<u>Reading for Meaning Series</u>			
Reading for Meaning, 4	x	x	174
Reading for Meaning, 5	x	x	174
Reading for Meaning, 6	x	x	174
Reading for Meaning, 7	x	x	174
Reading for Meaning, 8	x	x	174
Reading for Meaning, 9	x	x	174
Reading for Meaning, 10	x	x	174
Reading for Meaning, 11	x	x	174
Reading for Meaning, 12	x	x	174
<u>Reading for Understanding Series</u>			
Reading for Understanding Jr. Edition	x	x x x x x x	175
Reading for Understanding General Edition	x	x x x x x x	175
Reading for Understanding Sr. Edition	x	x x x x x x	175
<u>SRA Pilot Libraries</u>			
Pilot Library IIa	x	x x x x x x	168
Pilot Library IIb	x	x x x x x x	168
Pilot Library IIc	x	x x x x x x	169
Pilot Library IIId	x	x x x x x x	169

SKILL AREA - TITLES	INTEREST LEVELS		INSTRUCTIONAL LEVELS											DES- CRITION PAGE NO.				
	K-R	1-2 3-4 5-6 7-8 9-12	K	R	P	1	2	3	4	5	6	7	8		9	10	11	12
<u>SRA Reading Laboratories</u>																		
SRA Lab IIIa	x	x	x	x	x	x	x	x	x	x	x	x	x	x	x	x	x	180
SRA Lab IIIb	x	x																180
<u>Stories for Teen-Agers</u>																		
Stories for Teen-Agers, Book A, Red	x	x																181
Stories for Teen-Agers, Book B, Blue	x	x																181
Stories for Teen-Agers, Book C, Yellow	x	x																181
Stories for Teen-Agers, Book D, Green	x	x																181
<u>Turner-Livingston Communication Series</u>																		
The Language You Speak	x	x																19E
The Letters You Write	x	x																195
The Movies You See	x	x																195
The Newspapers You Read	x	x																195
The Phone Calls You Make	x	x																195
The Television You Watch	x	x																195
<u>World of Adventure Series</u>																		
Fire on the Mountain	x	x																200
Flight to the South Pole	x	x																200
Hunting Grizzly Bears	x	x																200
Lost Uranium Mine	x	x																200
City Beneath the Sea																		200
The Search for Piranha																		200
Sacred Well of Sacrifice																		200
Viking Treasure																		200

SKILL AREA

COMPREHENSION

<u>SKILL AREA - TITLES</u>	<u>INTEREST LEVELS</u>	<u>INSTRUCTIONAL LEVELS</u>	<u>DESCRIPTION</u> <u>PAGE NO.</u>
<u>GENERAL</u>			
<u>Adult Readers</u>			
A Race to Remember First at the Finish Guides to High Adventure "I Fell 18,000 Feet" Men Who Dare the Sea Mystery of the Mountains Sante Fe Traders Second Change "Send for Red" Valley of 10,000 Smokes What's on the Moon? Workers in the Sky	x x x x x x x x x x x x x x	K R P 1 2 3 4 5 6 7 8 9 10 11 12 x	119 119 119 119 119 119 119 119 119 119 119 119 119 119
<u>Building Reading Skills Series</u>			
Atomic Submarine Book Jet Plane Book Rocket Book Space Ship Book Speedboat Book Streamliner Book	x x x x x x x x x x x x x x	x x x x x x x	126 126 126 126 126
Decoding For Reading	x	x x x x x	132
Dr. Spello	x	x x x x	135
<u>Gates Peardon Reading Exercises</u>			
Introductory - Level A Introductory - Level B Preparatory - Level A Preparatory - Level B	x x x x x x x x	x x x x x x x x x x x x	141 141 141 141

SKILL AREA - TITLES	INTEREST LEVELS												INSTRUCTIONAL LEVELS												DES- CRPTION PAGE NO.
	K-R	1-2	3-4	5-6	7-8	9-12	K	R	P	1	2	3	4	5	6	7	8	9	10	11	12				
<u>Gates Peardon Reading Exercises con't</u>																									
Elementary - SA (Story About)			X	X																		141			
Elementary - RD (Can You Remember Details)			X	X																		141			
Elementary - FD (Can You Follow Directions)			X	X	X																	141			
Intermediate - SA, FD, RD				X	X	X																141			
Advanced - SA, FD, RD				X	X	X																141			
<u>Gateway Series, Level Three Anthologies</u>																									
Rebels and Regulars					X	X																141			
People in Poetry					X	X																141			
Something Strange					X	X																141			
Ways of Justice					X	X																141			
<u>Kaleidoscope of Skills</u>																									
Book 5-1 Red/Silver					X	X																146			
Book 5-2 Gold					X	X																146			
Book 5-3 Lavender					X	X																146			
Book 5-4 Olive					X	X																146			
Book 6-1 Orange/Aqua					X	X																146			
Book 6-2 Tan					X	X																146			
Book 6-3 Purple					X	X																146			
Book 6-4 Lime					X	X																146			
Book 7-1 Rust/Blue					X	X																146			
Book 7-2 Yellow					X	X																146			
Book 7-3 Green					X	X																146			

SKILL AREA GENERAL

SKILL AREA - TITLES	INTEREST LEVELS													INSTRUCTIONAL LEVELS													DES- CRPTION PAGE NO.
	K-R	1-2	3-4	5-6	7-8	9-12	K	R	P	1	2	3	4	5	6	7	8	9	10	11	12						
<u>Learning to Read While Learning to Learn</u>	x				x																		148				
The Purple Snail					x																		148				
Happy the Hippo					x																		148				
The Peculiar Lawn Mower					x																		148				
Pedro's Secret					x																		148				
Dognappers					x																		148				
Loud and Clear					x																		148				
Operation Phoenix					x																		148				
Viceroy's Daughter					x																		148				
Behind the Scenes					x																		148				
Rescue on the Mountains					x																		148				
A Place for Joe					x																		148				
Chilling Escape					x																		148				
Hundred Milers					x																		148				
Racing the Sait					x																		148				
Deadline for Time					x																		148				
The Big Break					x																		148				
Julius Caesar					x																		148				
<u>Manpower and Natural Resources Kit</u>																							152				
<u>McCall-Crabb Series</u>																							153				
McCall Crabb, Book A																							153				
McCall Crabb, Book B																							153				
McCall Crabb, Book C																							153				
McCall Crabb, Book D																							153				
McCall Crabb, Book E																							153				

SKILL AREA

GENERAL

<u>SKILL AREA - TITLES</u>	<u>INTEREST LEVELS</u>	<u>INSTRUCTIONAL LEVELS</u>	<u>DES- CRPTION PAGE NO.</u>
	<u>K-R 1-2 3-4 5-6 7-8 9-12</u>	<u>K R P 1 2 3 4 5 6 7 8 9 10 11 12</u>	
<u>Miami Linguistic Readers</u>			
Biff and Tiff	X		154
Kid, Kit and the Catfish	X		154
Nat the Rat	X		154
Tug Duck and the Buzz Bug	X		154
The Sack Hut	X		154
On the Rock in the Pond	X		154
The Picnic Ship	X		154
Hot Corn Muffins!	X		154
The Camping Trip	X		154
The Magic Bean	X		154
Chang's Shell	X		154
Dick's Cat	X		154
Rumpelstiltskin	X		154
On Sunfish Island	X		154
Mark's Jet	X		154
Matt and the Black Cat	X		154
B is for Bicycle	X		154
White Horse	X		154
The Man on the Penny	X		154
The Twin Mystery	X		154
<u>New Modern Reading Skill Texts</u>			159
New Modern Reading Skilltexts, Book 1	X		159
New Modern Reading Skilltexts, Book 2	X		159
New Modern Reading Skilltexts, Book 3	X		159
<u>Reader's Digest Practicer Pads</u>			
Practice Pad 1	X		170
Practice Pad 2	X		170
Practice Pad 3	X		170

<u>SKILL AREA - TITLES</u>	<u>INTEREST LEVELS</u>	<u>INSTRUCTIONAL LEVELS</u>	<u>DESCRIPTION PAGE NO.</u>
<u>Reader's Digest New Reading Skill Builders</u>	K-R 1-2 3-4 5-6 7-8 9-12	K R P 1 2 3 4 5 6 7 8 9 10 11 12	
Level 1	x x	x x	160
Part 1	x	x	160
Part 11	x	x	160
Level 1.1	x	x	160
Part 1	x	x	160
Part 11	x	x	160
Level 2	x	x	160
Part 1	x	x	160
Part 11	x	x	160
Level 3	x	x	160
Part 1	x	x	160
Part 11	x	x	160
Level 4	x	x	160
Part 1	x	x	160
Part 11	x	x	160
Level 5	x	x	160
Part 1	x	x	160
Part 11	x	x	160
Level 6	x	x	160
Part 1	x	x	160
Part 11	x	x	160
<u>Advanced Reading Skill Builder</u>	K-R 1-2 3-4 5-6 7-8 9-12	K R P 1 2 3 4 5 6 7 8 9 10 11 12	
Level 7	x	x	160
Book One	x	x	160
Book Two	x	x	160
Level 8	x	x	160
Book Three	x	x	160
Book Four	x	x	160
Reading Attainment I	x	x x	172

SKILL AREA GENERAL

<u>SKILL AREA - TITLES</u>	<u>INTEREST LEVELS</u>	<u>INSTRUCTIONAL LEVELS</u>	<u>DES- CRIPION PAGE NO.</u>
Reading Attainment II	x	x x x	173
<u>Readingtime Books</u>			
The Parade	x	x	176
A Friend for Jenny	x	x	176
Olly's Alligator	x	x	176
The New Boy	x	x	176
Ted's Garden	x	x	176
Three Billy Goats Gruff	x	x	176
Something to Tell	x	x	176
The big Whistle	x	x	176
I Like Cowboys	x	x	176
That Smart Dog, Sam	x	x	176
Spaceship of Your Own	x	x	175
Randy's Holiday	x	x	176
The Brave Little Plant	x	x	176
Rainy	x	x	176
Scared Kitten	x	x	176
The Adventures of Polly Peter	x	x	176
Seven at One Blow	x	x	176
The Princess on the Glass Hill	x	x	176
Good-by, Tree	x	x	176
Mr. Skinny Arms	x	x	176
Spider Legs	x	x	176
Where Were You When the Bell Rang,	x	x	176
and The Three Tailors	x	x	176
Lonnie, and the Flicker Family	x	x	176
Three for the Money	x	x	176
Phillip and the Ninety-nine Frogs	x	x	176
The Emperor and the Nightengale	x	x	176
Who Did It?	x	x	176

SKILL AREA - TITLES	INTEREST LEVELS												INSTRUCTIONAL LEVELS												DES- CRPTION PAGE NO.
	K-R	1-2	3-4	5-6	7-8	9-12	K	R	P	1	2	3	4	5	6	7	8	9	10	11	12				
<u>Singer Structural Series</u>																									
Pupil Books	x		x																				177		
Key-Picture Cards	x	x	x																				177		
Sound Picture Cards	x		x																				177		
Reading Dominoes	x	x	x																				177		
Vocabulary Development Booklets	x		x																				177		
<u>SRA Reading Laboratory</u>																							180		
SRA Lab. IIIa					x																		180		
SRA Lab. IIId					x																		180		
<u>Sullivan Programmed Reading</u>																							182		
Book 1																							182		
Book 2																							182		
Book 3																							182		
Book 4																							182		
Book 5																							182		
Book 6																							182		
Book 7																							182		
Book 8																							182		
Book 9																							182		
Book 10																							182		
Book 11																							182		
Book 12																							182		
Book 13																							182		
Book 14																							182		
Book 15																							182		
Book 16																							182		
Book 17																							182		
Book 18																							182		
Book 19																							182		
Book 20																							182		
Book 21																							182		

<u>SKILL AREA - TITLES</u>	<u>INTEREST LEVELS</u> X-R 1-2 3-4 5-6 7-8 9-12	<u>INSTRUCTIONAL LEVELS</u> K R P 1 2 3 4 5 6 7 8 9 10 11 12	DES- CRPTION PAGE NO.
<u>Universal Workbooks in Phonics (1-5)</u>			
Universal Workbooks in Phonics (1)	x x x x x	x	196
Universal Workbooks in Phonics (2a)	x x x x x	x	196
Universal Workbooks in Phonics (2b)	x x x x x	x	196
Universal Workbooks in Phonics (3a)	x x x x x	x	196
Universal Workbooks in Phonics (3b)	x x x x x	x	196
Universal Workbooks in Phonics (4a)	x x x x x	x	196
Universal Workbooks in Phonics (4b)	x x x x x	x	196
Universal Workbooks in Phonics (5)	x x x x x	x	196
<u>Webster Reading Clinic 10X</u>			197
Conquests in Reading	x	x x x x x	197
The Magic World of Dr. Spello	x x	x x x x x	197
Reading Skill Cards	x x x x x	x x x x x	197
New Webster Word Wheels	x x x x x	x x x x x	197
The Everyreader Series	x x x x x	x x x x x	197
Group Word Teaching Game	x x x x x	x x x x x	197
Basic Sight Vocabulary Cards	x x x x x	x x x x x	197
<u>World of Adventure Series</u>			200
Lost Uranium Mine	x	x	200
Flight to the South Pole	x	x	200
Hunting Grizzly Bears	x	x	200
Fire on the Mountain	x	x	200
City Beneath the Sea	x	x	200
The Search for Piranha	x	x	200
Sacred Well of Sacrifice	x	x	200
Viking Treasure	x	x	200

HANDWRITING
INDEPENDENT READERS

SKILL AREA

SKILL AREA - TITLES	INTEREST LEVELS K-R 1-2 3-4 5-6 7-8 9-12	INSTRUCTIONAL LEVELS K R P 1 2 3 4 5 6 7 8 9 10 11 12	DES- CRPTION PAGE NO.
<u>HANDWRITING</u>			
Peterson Handwriting Series			163
Improve Your Writing for Job Success, Basic Text (Sr. High)	x	x x x x x x	163
Handwriting Legibility Kit for Young Adults (Learner)	x	x x x x x x	163
<u>INDEPENDENT READERS</u>			
Bowmar Reading Incentive Program			125
Karting	x	x x	125
The Mighty Midgets	x	x x	125
Slot Car Racing	x	x x	125
Motorcycles	x	x x	125
Drag Racing	x	x x	125
Teen Fair	x	x x	125
Horses	x	x x	125
Surfing	x	x x	125
Drag Racing - Funny Cars	x	x x	125
Dune Buggies	x	x x	125
Dune Buggy Racing	x	x x	125
Custom Cars	x	x x	125
Bowmar Reading Incentive Program			126
Multi-Media Kit	x	x x	126

<u>SKILL AREA - TITLES</u>	<u>INTEREST LEVELS</u>	<u>INSTRUCTIONAL LEVELS</u>	<u>DES- CRPTION PAGE NO.</u>
	<u>K-R 1-2 3-4 5-6 7-8 9-12</u>	<u>K R P 1 2 3 4 5 6 7 8 9 10 11 12</u>	
<u>Checked Flag Learning System</u>			
Classroom Kit A			
Wheels	x x x x	x x	127 127
Riddler	x x x x	x x	127 127
Bearcat	x x x x	x x	127 127
Smashup	x x x x	x x	127 127
Classroom Reading Kit B			
Scramble	x x x x	x	127 127
Flea	x x x x	x	127 127
Grand Prix	x x x x	x	127 127
500	x x x x	x	127 127
<u>Checked Flag Learning System</u>			
Audio Visual Kit A			127
Audio Visual Kit B	x x x x	x x x x	127 127
<u>Deep Sea Adventure Series</u>			
The Sea Hunt	x x	x x x x x	132
Treasure Under the Sea	x x	x	132
Submarine Rescue	x x x x	x	132
The Pearl Divers	x x x x	x	132
Frogmen in Action	x x x x	x	132
Danger Below	x x x x	x	132
Whale Hunt	x x x x	x	132
Rocket Divers	x x	x	132

SKILL AREA

INDEPENDENT READERS

SKILL AREA - TITLES	INTEREST LEVELS												INSTRUCTIONAL LEVELS												DESCRPTION PAGE NO.
	K-1	1-2	2-4	4-6	5-6	7-8	9-12	K	R	F	1	2	3	4	5	6	7	8	9	10	11	12			
<u>Jim Forest Readers</u>																							145		
Jim Forest and Ranger Don				x	x																		145		
Jim Forest and the Trapper				x	x																		145		
Jim Forest and the Ghost Town				x	x																		145		
Jim Forest and the Bandits				x	x																		145		
Jim Forest and Lightning				x	x																		145		
<u>Dolch Readers</u>																							134		
Big, Bigger, Biggest																							134		
Dog Pals																							134		
Friendly Birds																							134		
I Like Cats																							134		
In the Woods																							134		
Making Friends																							134		
On the Farm																							134		
Some are Small																							134		
Tommy's Pets																							134		
Zoo Is Home																							134		
Once There Was a Rabbit																							134		
Once There Was an Elephant																							134		
Once There Was a Monkey																							134		
Once There Was a Dog																							134		
<u>Merrill Mainstream</u>																							154		
Courage Under Fire																							154		
Against the Odds																							154		
They Were First																							154		
In New Directions																							154		
People Like You																							154		

<u>SKILL AREA - TITLES</u>	<u>INTEREST LEVELS</u>	<u>INSTRUCTIONAL LEVELS</u>	<u>DESCRIPTIVE PAGE NO.</u>
	<u>K-R 1-2 3-4 5-6 7-8 9-12</u>	<u>K R P 1 2 3 4 5 6 7 8 9 10 11 12</u>	
<u>Morgan Bay Mystery Series</u>			
Mystery of Morgan Castle	X X X X X X	X	156
Mystery of the Marble Angel	X X X X X X	X X	156
Mystery of the Midnight Visitor	X X X X X X	X	156
Mystery of the Musical Ghost	X X X X X X	X X	156
Mystery of the Missing Marlin	X X X X X X	X X	156
Mystery of Monk's Island	X X X X X X	X X	155
Mystery of Marauder's Gold	X X X X X X	X X	156
Mystery of the Myrmidon's Journey	X X X X X X	X	156
<u>Motivation Readers</u>			
Blue Dog	X X		158
The Flying Squirrels	X X	X X	158
The Almost Ghost	X X X X	X	158
The Barking Cat	X X X X	X X	158
Better Than Gold	X X X X	X X	158
Three Green Men	X X	X	158
<u>Mystery Adventure Series</u>			
Mystery Adventure Reader I	X X	X X	158
Mystery Adventure Reader II	X X	X X X X	158
Mystery Adventure of the Talking Statues	X X	X	158
Mystery Adventure of the Jeweled Ball	X X X X	X X	158
Mystery Adventure of Cave Four	X X X X	X	158
Mystery Adventure of the Indian Burial Ground	X X X X	X X	158
Mystery Adventure of Loagcliff Inn	X X X X	X X	158
Mystery Adventure of Smuggled Treasure	X X	X	158

<u>SKILL AREA - TITLES</u>	<u>INTEREST LEVELS</u> K-R 1-2 3-4 5-6 7-8 9-12	<u>INSTRUCTIONAL LEVELS</u> K R P 1 2 3 4 5 6 7 8 9 10 11 12	DES- CRPTION PAGE NO.
<u>On Target (Reading for Pleasure Series)</u>			
On Target	x		161
Top Flight	x	x x x	161
In Orbit	x	x x x	161
<u>Phonetic Readers Series</u>			
Puss in Boots	x	x	164
Jack the Giant Killer	x	x	164
Jack and the Beanstalk	x	x x	164
Alladdin and the Wonderful Lamp	x	x x	164
Ali Baba and the Forty Thieves	x	x x	164
Robinson Crusoe	x	x x	164
<u>Phonetic Reading Series</u>			
Mac and Tab	x	x x	164
The Tin Man	x	x x	164
A 1	x	x x	164
Ben Bug	x	x x	164
Ed	x	x x	164
Ted	x	x x	164
The Wig	x	x x	164
<u>Pacesetters in Personal Reading</u>			
The Fish Who Weren't	x	x	166
Moon City	x	x	166
Thief in the Basement	x	x	166
Widdershins	x	x	166
Unwilling Witch	x	x	166
The Thousand Voices of			
Timothy Reese	x	x	166

<u>SKILL AREA - TITLES</u>	<u>INTEREST LEVELS</u>	<u>INSTRUCTIONAL LEVELS</u>	<u>DES-CAPTION PAGE NO.</u>
<u>Sullivan Storybooks, Classroom Library Set</u>	K-R 1-2 3-4 5-6 7-8 9-12	K R P 1 2 3 4 5 6 7 8 9 10 11 12	182
Sullivan Storybook, Classroom Library Set	x x x x	x x x x	182
<u>Stories for First Phonics</u>	x x x x	x x x x	179
<u>Royal Road Miniature Readers</u>	x x x x	x	175
Fip, the Pet Rabbit	x	x	175
Jill's Best Frock	x	x	175
The Picnic	x	x	175
The Robins	x	x	175
The Bull-dog and the Kitten	x	x	175
The Swimming Lesson	x	x	175
The Kitten and the Straps	x	x	175
The Cat and the Fed	x	x	175
<u>Teen-Age Tales (A, B, C)</u>	x x x	x x x	189
Teen-Age Tales, Book A	x	x	189
Teen-Age Tales, Book B	x	x	189
Teen-Age Tales, Book C	x	x	189
<u>Teen-Age Tales (1-6)</u>	x x x x x x	x x x	189
Teen-Age Tales, Book 1	x	x	189
Teen-Age Tales, Book 2	x	x	189
Teen-Age Tales, Book 3	x	x	189
Teen-Age Tales, Book 4	x	x	189
Teen-Age Tales, Book 5	x	x	189
Teen-Age Tales, Book 6	x	x	189

SKILL AREA - TITLES	INTEREST LEVELS												INSTRUCTIONAL LEVELS												DES-CRIPTION PAGE NO.
	K-R	1-2	3-4	5-6	7-8	9-12	K	R	P	1	2	3	4	5	6	7	8	9	10	11	12				
<u>The Literature Sampler</u>																								151	
<u>The Time Machine Series</u>																								190	
Leonard Visits Space																								190	
Leonard Visits the Ocean Floor																								190	
Leonard Discovers America																								190	
Leonard Visits Dinosaur Land																								190	
Leonard Visits Sitting Bull																								190	
Leonard Goes to the Olympics																								190	
Leonard Equals Einstein																								190	
Leonard Discovers Einstein																								190	
<u>We Read More Stories Series</u>																								198	
The Three Billy Goats Gruff																								198	
The Old Woman and Her Pig																								198	
Little Sambo																								198	
Aesop's Fables																								198	
The Three Bears																								198	
The Little Red Hen																								198	
The Little Engine That Could																								198	
The Gingerbread Boy																								198	
The Boy and the Goats																								198	
The Little Red Hen and the Fox																								198	
The House That Jack Built																								198	
All Mine and Kindness																								198	
Nursery Rhymes																								198	
The Wishing Book																								198	
The Lambkin																								198	
Gentle As A Lamb																								198	
How the Robin Got His Red-Breast																								198	
Winter																								198	
Summer																								198	
Spring																								198	
Fall																								198	

SKILL AREA - TITLES	INTEREST LEVELS	INSTRUCTIONAL LEVELS	DESCRIPTION PAGE NO.
<u>Wildlife Adventure Series</u>			
Gatie the Alligator	x x x x	x	197
Sleeky the Otter	x x x x	x	197
Skipper the Dolphin	x x x x	x	197
Tammy the Mountain Lion	x x	x	197
Bouncer the Jack-rabbit	x x	x	197
Thor the Moose	x x	x	197
Ruff the Wolf	x x	x	197
Arctos the Grizzly	x	x	197
<u>"What Job for Me" Series</u>			
Charley the TV Repairman	x	x	198
John the Second Best Cook in Town	x	x	198
Pete the Service Station Attendant	x	x	198
Nick the Waiter	x	x	198
Joe the Retail Salesman	x	x	198
Judy the Waitress	x	x	198
Frank the Vending Machine Repairman	x	x	198
Betty and Her Typewriter	x	x	198
Ginny the Office Assistant	x	x	198
Carman the Beautician	x	x	198
Cool It, Men!	x	x	198
Phil the File Clerk	x	x	198
Sandy the Lineman	x	x	198
Tom the Merchant Seaman	x	x	198
Tim the Draftsman	x	x	198
Keep It Clean	x	x	198
Burt the Policeman	x	x	198
Ned the Taxicab Driver	x	x	198

LETTER AND NUMBER RECOGNITION
LANGUAGE DEVELOPMENT

SKILL AREA - TITLES	INTEREST LEVELS	INSTRUCTIONAL LEVELS	DES- CRIPTION PAGE NO.
<u>LANGUAGE DEVELOPMENT</u>			
<u>Peabody Language Development Kits</u>			
Kit P			
Kit 1	X	X X X X	166
Kit 2	X	X X X X X X	166
Kit 3	X	X X X X X X X	166
<u>LETTER AND NUMBER RECOGNITION</u>			
<u>Flash-X Programs</u>			
Set X-1 Readiness Pictures	X	X X X X X	138
Set X-2 Primary Recognition	X	X X X X X X X	138
Set X-3 Basic Accuracy-Numbers	X	X X X X X X X X X	138
Set X-4 Basic Accuracy-Letters	X	X X X X X X X X X	138
Set X-5 Sight Vocabulary	X	X X X X X	138
Set X-6 Sight Vocabulary	X	X X X X X	138
Set X-10 Sight Vocabulary	X	X X X X X	138
Set X-12 Spelling Level 2	X	X X X X X	138
Set X-13 Spelling Level 3	X	X X X X X X	138
Set X-14 Spelling Level 4	X	X X X X X X X	138
<u>System 80 Program</u>			
<u>Learning Letter Names:</u>			
Kit A	X	X X X X X X	183
Kit B	X	X X X X X X	183
<u>Developing Spelling Skills:</u>			
Kits A, B, C, D, E, F, G	X	X X X X X X X	183
<u>Reading Words in Context:</u>			
Kits A, B, C, D, E, F, G, H	X	X X X X X X X	183

SKILL, AREA

LETTER AND NUMBER RECOGNITION
LISTENING SKILLS

SKILL AREA - TITLES	INTEREST LEVELS	INSTRUCTIONAL LEVELS	DESCRIPTION PAGE NO.
<u>T-Matic Filmstrips</u>			
Span of Perception PTF-3	K-R 1-2 3-4 5-6 7-8 9-12	K R P 1 2 3 4 5 6 7 8 9 10 11 12	192
Letter Recognition ROF-1	x x x x x x	x x x x x x x x x x x x	192
<u>Teaching Typewriter Programs</u>			
Animal Friends	x	x x x x	188
Discovering Colors	x x x	x x x x	188
Exploring Numbers 1-5	x x x x	x x x x	188
Learning to Count	x x x x	x x x x	188
Alphabet Progression	x x x x	x x x x	188
Reading and Spelling (Beginners)	x	x x x x	188
Reading and Spelling (Fun with Words) - 2 Sets	x x x	x x x x	188
Exploring Numbers 1-10	x x x	x x x x	188
Opposites - 10 Concepts	x	x x x x	188
<u>LISTENING SKILLS</u>			
<u>Listen and Think Series (Tapes)</u>			
Listen and Think A-R	x x x x x x x x x x x x x x x x	x x x x x x x x x x x x x x x x	149
Listen and Think B			149
Listen and Think C			149
Listen and Think D			149
Listen and Think E			149
Listen and Think F			149
Listen and Think G			149
Listen and Think H			149
Listen and Think I			149

SKILL AREA LISTENING SKILLS
PERCEPTUAL DEVELOPMENT

<u>SKILL AREA - TITLES</u>	<u>INTEREST LEVELS</u>	<u>INSTRUCTIONAL LEVELS</u>	<u>DES-CRITION PAGE NO.</u>
<u>Wollensak Teaching Tapes</u>			
Introduction to the Listening Experience			199
Sounds at Home	X X X X X X X X X X	K R P 1 2 3 4 5 6 7 8 9 10 11 12	199
Sounds We See	X X X X X X X X X X		199
Walking Sounds	X X X X X X X X X X		199
Word Attack Skills (Approx. 50 tapes)	X X X X X X X X X X		199
Syllables	X X X X X X X X X X		199
<u>Tok-Back</u>	X X X X X X X X X X		193
<u>PERCEPTUAL DEVELOPMENT</u>			
<u>Craig Reader Programs</u>			131
Perception I, II, III (16 lessons each)	X X X X X X X X X X		131
C (30 lessons)	X X X X X X X X X X		131
C-1 (32 lessons)	X X X X X X X X X X		131
C-2 (30 lessons)	X X X X X X X X X X		131
C-3 (30 lessons)	X X X X X X X X X X		131
C-4 (35 lessons)	X X X X X X X X X X		131
C-5 (40 lessons)	X X X X X X X X X X		131
Reading Skills I	X X X X X X X X X X		131
Roots I/Roots II	X X X X X X X X X X		131
<u>Detect Tactile</u>	X X X X X X X X X X		133
<u>Frostig Development Program</u>	X X X X X X X X X X		139

SKILL AREA PERCEPTUAL DEVELOPMENT

<u>SKILL AREA - TITLES</u>	<u>INTEREST LEVELS</u>	<u>INSTRUCTIONAL LEVELS</u>	<u>DES- CRPTION PAGE NO.</u>
<u>Frostig Test Material</u>	<u>K-R 1-2 3-4 5-6 7-8 9-12</u>	<u>K R P 1 2 3 4 5 6 7 8 9 10 11 12</u>	140
Frostig Test Specimen Set	x	x x x x x x	140
Frostig Test Booklet	x	x x x x x x	140
Frostig Program Box	x	x x x x x x	140
<u>Perception Filmstrips</u>			162
Developing Cognitive Skills for Young Learners	x	x x x x x x	162
Visual Perception Skills	x	x x x x x x	162
Developing Body Space Perception Motor Skills	x	x x x x x x	162
<u>School Skill Tracing Board</u>	x	x x x x x	178
<u>Shapes Around Us Series</u>			178
What Is Round?	x	x x	178
What Has Three Sides?	x	x x	178
What Has Four Sides?	x	x x	178
What Comes In a Box?	x	x x	178
What Shape Is It?	x	x x	178
<u>Tachistoscope Filmstrips</u>			184
Set ABC Basic Accuracy Filmstrips	x	x x x x x x x	184
Look and Write	x	x x x x x x x	184
Set 22 Primary Supplementary	x	x x x x	184
Set 31 Intermediate Supplementary	x	x x x	184
Perceptual Readiness - Set 20	x	x x x x x	184
Primary Letters - Set 21	x	x x x x x x	184
Intermediate Numbers - Set 30	x	x x x x x x	184
Advanced Accuracy - Set 40	x	x x x x x x x	184

SKILL AREA - TITLES	INTEREST LEVELS												INSTRUCTIONAL LEVELS												DES- CRPTION PAGE NO.
	K-R	1-2	3-4	5-6	7-8	9-12	K	R	P	1	2	3	4	5	6	7	8	9	10	11	12				
<u>Tachistoscope Filmstrips con't.</u>																									
EDL Sight Vocabulary:																									
Set A	x	x	x	x	x	x	x	x	x	x	x	x	x	x	x	x	x	x	x	x	x	184			
Set B	x	x	x	x	x	x	x	x	x	x	x	x	x	x	x	x	x	x	x	x	x	184			
Set C	x	x	x	x	x	x	x	x	x	x	x	x	x	x	x	x	x	x	x	x	x	184			
Set D	x	x	x	x	x	x	x	x	x	x	x	x	x	x	x	x	x	x	x	x	x	184			
Set E	x	x	x	x	x	x	x	x	x	x	x	x	x	x	x	x	x	x	x	x	x	184			
Set F	x	x	x	x	x	x	x	x	x	x	x	x	x	x	x	x	x	x	x	x	x	184			
Set V-789																						184			
Set V-1011																						184			
Look at Words:																									
Set A	x	x	x	x	x	x	x	x	x	x	x	x	x	x	x	x	x	x	x	x	x	184			
Set B	x	x	x	x	x	x	x	x	x	x	x	x	x	x	x	x	x	x	x	x	x	184			
Set C	x	x	x	x	x	x	x	x	x	x	x	x	x	x	x	x	x	x	x	x	x	184			
Set D	x	x	x	x	x	x	x	x	x	x	x	x	x	x	x	x	x	x	x	x	x	184			
Set E	x	x	x	x	x	x	x	x	x	x	x	x	x	x	x	x	x	x	x	x	x	184			
Set F	x	x	x	x	x	x	x	x	x	x	x	x	x	x	x	x	x	x	x	x	x	184			
<u>T-Matic Filmstrips</u>																									
Span of Perception PTF-3 (20 Filmstrips)																									
Letter Recognition ROF-1 (20 Filmstrips)																									
Words and Phrases VCF-1 (20 Filmstrips)																									
Words and Phrases VCF-2 (20 Filmstrips)																									
Words and Phrases VCF-3 (20 Filmstrips)																									
Words and Phrases VCF-4 (20 Filmstrips)																									

SKILL AREA - TITLES	INTEREST LEVELS	INSTRUCTIONAL LEVELS	DES- CRPTION PAGE NO.
	K-R 1-2 3-4 5-6 7-8 9-12	K R P 1 2 3 4 5 6 7 8 9 10 11 12	
<u>T-Matic Filmstrips con't.</u>			
Words and Phrases VCF-5 (20 Filmstrips)	x x x	x	192
Words and Phrases VCF-6 (20 Filmstrips)	x x x	x	192
Remedial Reading Filmstrips RRF-1 (20 Filmstrips)	x x x	x	192
Spelling Word List SDF-2 (30 Filmstrips)	x x x	x	192
Spelling Word List SDF-3 (30 Filmstrips)	x x x	x	192
Spelling Word List SDF-4 (30 Filmstrips)	x x x	x	192
Spelling Principle: (30 Filmstrips)	x x x	x x x x	192
<u>Winter Haven Lions Program</u>			199
Teacher's Basic Perceptual Testing and Training Kit	x x x	x x x x x	199
TRY Experience for Young Children	x x	x x x x x	199
Tangrams	x x x	x x x x x x	199
<u>PHONICS</u>			
<u>Barnell-Loft Specific Skills</u>			121
Working with Sounds A	x x x	x	121
Working with Sounds B	x x x	x	121
Working with Sounds C	x x x	x x	121
Working with Sounds D	x x x	x	121

SKILL AREA - TITLES
First Experience With Vowels and Consonants

Phonics In A Nutshell
 Phonics Is Fun, Book 1
 Phonics Is Fun, Book 2
 Phonics Is Fun, Book 3

Ideal Listen-lock-Learn Teaching Tapes and Worksheets

Initial and Final Consonant
 (20 lessons)
 Blends and Digraphs (10 lessons)
 Vowel Tapes (20 lessons)
 Vowel Enrichment (20 lessons)
 Syllable Rule - Accent Clues
 (16 lessons)

Language Master Cards and Programs

- A. Blank Cards
- B. Phonics Program
 1. Sound Blending and Beginning Phonetic Skills Set I
 2. Consonant Blends and Irregular Phonetic Sounds Set II
 3. Word Building and Word Analysis Technique

INTEREST LEVELS

K-R 1-2 3-4 5-6 7-8 9-12

x	x	x	x	x	x	x	x	x	x	x	x	x	x	x	x	x	x
x	x	x	x	x	x	x	x	x	x	x	x	x	x	x	x	x	x
x	x	x	x	x	x	x	x	x	x	x	x	x	x	x	x	x	x
x	x	x	x	x	x	x	x	x	x	x	x	x	x	x	x	x	x

INSTRUCTIONAL LEVELS

K R P 1 2 3 4 5 6 7 8 9 10 11 12

x	x	x	x	x	x	x	x	x	x	x	x	x	x	x	x	x	x
x	x	x	x	x	x	x	x	x	x	x	x	x	x	x	x	x	x
x	x	x	x	x	x	x	x	x	x	x	x	x	x	x	x	x	x
x	x	x	x	x	x	x	x	x	x	x	x	x	x	x	x	x	x

 DES-
 CRIFTON
 PAGE NO.

136	165	165	165	144	144	144	144	144	144	148	148	148	148	148	148
-----	-----	-----	-----	-----	-----	-----	-----	-----	-----	-----	-----	-----	-----	-----	-----

 SKILL AREA PHONICS

SKILL AREA - TITLES	INTEREST LEVELS	INSTRUCTIONAL LEVELS	DES- CRPTION PAGE NO.
<u>Merrill Refresher Program of Linguistic Readers</u>			
Book A - Cloth	x	x x x x x x x	150
Book B - Cloth	x	x x x x x x x	150
Book C - Cloth	x	x x x x x x x	150
Book D - Cloth	x	x x x x x x x	150
<u>Phonics We Use Series</u>			167
Phonics We Use, Book A	x		167
Phonics We Use, Book B	x	x	167
Phonics We Use, Book C	x	x x	167
Phonics We Use, Book D	x	x x x	167
Phonics We Use, Book E	x	x x x x	167
Phonics We Use, Book F	x	x x x x x	167
Phonics We Use, Book G	x	x x x x x x	167
<u>Phonics With Write and See</u>			167
Phonics With Write and See, A	x	x x x x	167
Phonics With Write and See, B	x	x x x x	167
<u>Primary Phonics</u>			171
Workbook One	x		171
Workbook Two	x		171

SKILL AREA PHONICS

SKILL AREA - TITLES	INTEREST LEVELS												INSTRUCTIONAL LEVELS												DES- CRIPTION PAGE NO.
	K-R	1-2	3-4	5-6	7-8	9-12	K	R	P	1	2	3	4	5	6	7	8	9	10	11	12				
<u>Spelling Word Power Laboratories</u>																								179	
Spelling Word Power Lab IIa					x	x																		179	
Spelling Word Power Lab IIb					x	x																		179	
Spelling Word Power Lab IIc					x	x																		179	
Spelling Word Power Lab IIIa					x	x																		179	
<u>Webster Reading Clinic</u>																								197	
Conquests in Reading																								197	
The Magic World of Dr. Spello																								197	
Reading Skill Cards																								197	
New Webster Word Wheels																								197	
The Everyreader Series																								197	
Group Word Teaching Game																								197	
Basic Sight Vocabulary Cards																								197	
<u>Words in Color</u>																								200	
<u>Wollensak Teaching Tapes</u>																								199	
Introduction to the Listening Experience																								199	
Sounds at Home																								199	
Sounds We See																								199	
Walking Sounds																								199	
Word Attack Skills: Approx. 50 tapes on recognition and location of long and short vowels and consonants																								199	
Syllables																								199	
Sight and Sound of Phonics																								177	

SKILL AREA - TITLES	INSTRUCTIONAL LEVELS												DES- CRPTION PAGE NO.			
	K	R	P	1	2	3	4	5	6	7	8	9		10	11	12
<u>Better Reading Books</u>																
Better Reading, Book 1																
Better Reading, Book 2																
Better Reading, Book 3																
<u>Controlled Reader Filmstrips</u>																
Controlled Reader Set CR-AA																
Controlled Reader Set CR-BA																
Controlled Reader Set CR-CA																
Controlled Reader Set CR-DA																
Controlled Reader Set CR-EA																
Controlled Reader Set CR-FA																
<u>Controlled Reader Filmstrips</u>																
CR-MT: Motility Training																
CR-AD: Accelerated Discrimination																
CR-A (Two Albums)																
CR-B (Two Albums)																
CR-C (Two Albums)																
CR-D (One Album)																
CR-DD (One Album)																
CR-E (One Album)																
CR-EE (One Album)																
CR-F (One Album)																
CR-FF (One Album)																
CR-GH (One Album)																
CR-HG (One Album)																
CR-IJ (One Album)																
CR-JI (One Album)																

<u>SKILL AREA - TITLES</u>	<u>INTEREST LEVELS</u>	<u>INSTRUCTIONAL LEVELS</u>	<u>DES- CRPTION PAGE NO.</u>
<u>SRA Reading Laboratory</u>			
SRA Lab IIIa	x x	x x x x x x x x	180
SRA Lab IIIb	x x	x x x x x x x x	180
<u>READINESS</u>			
<u>Ideal Listen-Look-Learn Reading Tapes and Workbooks</u>			
Reading Readiness Tapes (16 lessons, worksheets)	x x	x x x x	144
Initial and Final Consonant Tapes (20 lessons)	x x x x	x x x x x x	144
Vowel Tapes (20 lessons)	x x x x	x x x x x x	144
<u>Learning to Think Series</u>			
Red Book	x x	x x x x	149
Blue Book	x x	x x x x	149
Green Book	x x	x x x x	149
Gold Book	x x	x x x x	149
<u>REFERENCE</u>			
<u>Thesauri</u>			
In Other Words I	x x	x x	190
A Beginning Thesaurus			
In Other Words II	x x	x x	190
A Junior Thesaurus			

<u>SKILL AREA - TITLES</u>	<u>INTEREST LEVELS</u>	<u>INSTRUCTIONAL LEVELS</u>	<u>DESCRIPTION PAGE NO.</u>	<u>SKILL AREA</u>	<u>REFERENCE SPELLING</u>
<u>Thorndike-Barnhart Advanced Junior Dictionary (4th Edition)</u>	K-R 1-2 3-4 5-6 7-8 9-12 x x	K R P 1 2 3 4 5 6 7 8 9 10 11 12 x x	191		
<u>SPELLING</u>					
<u>Conquests in Reading</u>	x x x x	x x x x x	128		
<u>Flash-X Programs</u>			138		
Set X-1 Readiness Pictures	x	x x x x	138		
Set X-2 Primary Recognition	x	x x x x x	138		
Set X-4 Basic Accuracy-Letters	x	x x x x x x x x	138		
Set X-12 Spelling Level 2	x	x	138		
Set X-13 Spelling Level 3	x	x	138		
Set X-14 Spelling Level 4	x	x	138		
<u>Spelling Word Power Laboratories</u>			179		
Spelling Word Power Lab IIA	x	x	179		
Spelling Word Power Lab IIB	x	x	179		
Spelling Word Power Lab IIC	x	x	179		
Spelling Word Power Lab IIIA	x	x	179		
<u>System 80 Program</u>			133		
Learning Letter Names, Kit A	x	x x x x x	183		
Learning Letter Names, Kit B	x	x x x x x	183		
Developing Spelling Skills					
Kits A, B, C, D, E, F, G	x	x x x x x x	183		
Reading Words in Context					
Kits A, B, C, D, E, F, G, H	x	x x x x x x	183		
The Magic World of Dr. Spello	x	x x x x x	197		

SKILL AREA SPELLING
STRUCTURAL ANALYSIS

SKILL AREA - TITLES	INSTRUCTIONAL LEVELS												DES- CRPTION PAGE NO.			
	K	R	P	1	2	3	4	5	6	7	8	9		10	11	12
<u>Teaching Typewriter Programs</u>																188
Alphabet Progression	x	x														188
Reading and Spelling (Beginners)	x	x														188
<u>T-Matic Filmstrips</u>																192
Letter Recognition ROF-1 (20 Filmstrips)	x	x	x	x	x											192
Spelling Word List SDF-2 (30 Filmstrips)	x	x														192
Spelling Word List SDF-3 (30 Filmstrips)																192
Spelling Word List SDF-4 (30 Filmstrips)																192
Spelling Principles (30 Filmstrips)																192
<u>STRUCTURAL ANALYSIS</u>																
<u>Hoffman Reader Programs</u>																
Primary Achievement Units (10 Albums per unit)	x	x	x	x	x											142
3rd Level Achievement Units (10 Albums per unit)																142
4th Level Achievement Units (10 Albums per unit)																142
5th Level Achievement Units (10 Albums per unit)																142
6th Level Achievement Units (10 Albums per unit)																142
<u>Basic Language Skills</u>																
Books 1301 - 1306																156

<u>SKILL AREA - TITLES</u>	<u>INTEREST LEVELS</u>	<u>INSTRUCTIONAL LEVELS</u>	<u>DESCRIPTION PAGE NO.</u>
	<u>K-R 1-2 3-4 5-6 7-8 9-12</u>	<u>K R P 1 2 3 4 5 6 7 8 9 10 11 12</u>	
<u>Ideal Listen-Look-Learn Reading Tapes and Workbooks</u>			
Initial and Final Consonant Tapes			144
Blends and Diagraphs	x	x x x x x	144
Vowel Tapes	x	x x x x x	144
Vowel Enrichment	x	x x x x x	144
Syllable Rule - Accent Rules	x	x x x x x	144
<u>Study Scopes</u>			181
Study Scopes	x	x x x x x	181
<u>STUDY SKILLS</u>			
<u>How to Study</u>			
How to Study			147
<u>Reading for Meaning Series</u>			
Reading for Meaning, 4			174
Reading for Meaning, 5	x	x	174
Reading for Meaning, 6	x	x	174
Reading for Meaning, 7	x	x	174
Reading for Meaning, 8	x	x	174
Reading for Meaning, 9	x	x	174
Reading for Meaning, 10	x	x	174
Reading for Meaning, 11	x	x	174
Reading for Meaning, 12	x	x	174

SKILL AREA - TITLES	INTEREST LEVELS												INSTRUCTIONAL LEVELS												DTS-CRIFTON PAGE NO.
	K-R	1-2	2-4	3-4	5-6	7-8	9-12	K	R	P	1	2	3	4	5	6	7	8	9	10	11	12			
<u>VISUAL DISCRIMINATION</u>																									
<u>Controlled Reader Filmstrips</u>																									
CR-MT: Motility Training																									
CR-AD: Accelerated Discrimination																									
CR-A (Two Albums)																									
CR-B (Two Albums)																									
CR-C (Two Albums)																									
CR-D (Two Albums)																									
CR-DD (One Album)																									
CR-E (One Album)																									
CR-EE (One Album)																									
CR-F (One Album)																									
CR-FF (One Album)																									
FR-GH (One Album)																									
CR-HG (One Album)																									
CR-IJ (One Album)																									
CR-JI (One Album)																									
<u>Detect Visual Program</u>																									
<u>Michigan Language Program</u>																									
<u>Michigan Tracking Program</u>																									
<u>VOCABULARY</u>																									
<u>Be A Better Reader Series</u>																									
Be A Better Reader I																									
Be A Better Reader II																									
Be A Better Reader III																									

SKILL AREA - TITLES	INTEREST LEVELS	INSTRUCTIONAL LEVELS	DES- CRPTION PAGE NO.
<u>Be A Better Reader Series con't.</u>	K-R 1-2 3-4 5-6 7-8 9-12	K R P 1 2 3 4 5 6 7 8 9 10 11 12	124 124 124 124 124 124
Be A Better Reader IV	x	x	131
Be A Better Reader V	x	x	131
Be A Better Reader IV	x	x	131
Be A Better Reader, Book A	x	x	131
Be A Better Reader, Book B	x	x	131
Be A Better Reader, Book C	x	x	131
<u>Craig Reader Programs</u>			
C (30 lessons)	x	x	131
C-1 (3- lessons)	x	x	131
C-2 (3; lessons)	x	x	131
C-3 (30 lessons)	x	x	131
C-4 (30 lessons)	x	x	131
C-5 (40 lessons)	x	x	131
Reading Skills I	x	x	131
Roots I/Roots II	x	x	131
<u>Language Master Cards and Programs</u>			
Blank Cards	x	x	148
Phonic Programs:			
x	x	148	
x	x	148	
x	x	148	
x	x	148	
x	x	148	
x	x	148	
Word Picture Program:			
x	x	148	
x	x	148	
x	x	148	

SKILL AREA VOCABULARY

SKILL AREA - TITLES	INTEREST LEVELS												INSTRUCTIONAL LEVELS												DES- CRPTION PAGE NO.
	K-R	1-2	3-4	5-6	7-8	9-12	K	R	P	1	2	3	4	5	6	7	8	9	10	11	12				
<u>Language Master Cards and Programs</u> con't																									
Building Basic English, A			x	x	x	x																	148		
Building Basic English, B			x	x	x	x																	148		
<u>MacMillan Reading Spectrum</u>																							152		
Spectrum of Skills, Development Kit					x																		152		
<u>Mott Basic Language Skills Program</u>																							157		
Basic Language Skills, Book 1307					x																		157		
Basic Language Skills, Book 1308					x																		157		
Basic Language Skills, Book 1309					x																		157		
Basic Language Skills, Book 1310					x																		157		
Word Bank					x																		157		
<u>EDL Word Clues Series</u>																							135		
EDL Word Clues, Book G					x																		135		
EDL Word Clues, Book H'					x																		135		
EDL Word Clues, Book I					x																		135		
EDL Word Clues, Book J					x																		135		
EDL Word Clues, Book K					x																		135		
EDL Word Clues, Book L					x																		135		
<u>New Practice Readers</u>																							159		
New Practice Readers, Book A			x	x	x	x																	159		
New Practice Readers, Book B			x	x	x	x																	159		
New Practice Readers, Book C					x	x																	159		
New Practice Readers, Book D					x	x																	159		
New Practice Readers, Book E					x	x																	159		
New Practice Readers, Book F					x	x																	159		
New Practice Readers, Book G					x	x																	159		

SKILL AREA - TITLES	INTEREST LEVELS												INSTRUCTIONAL LEVELS												DES- CRPTION PAGE NO.
	K-R	1-2	3-4	5-6	7-8	9-12	K	R	P	1	2	3	4	5	6	7	8	9	10	11	12				
<u>Pace setters in Personal Reading</u>																							166		
The Fish Who Weren't					X																		166		
Moon City					X																		166		
Thief in the Basement					X																		166		
Widdershins					X																		166		
Unwilling Mitch					X																		166		
The Thousand Voices of Timothy Reese					X																		166		
<u>Pilot Library, IIa</u>																							168		
<u>Pilot Library, IIb</u>																							168		
<u>Pilot Library, IIc</u>																							169		
<u>Pilot Library, IIIs</u>																							169		
<u>Reading for Concepts</u>																							173		
Reading for Concepts A																							173		
Reading for Concepts B																							173		
Reading for Concepts C																							173		
Reading for Concepts D																							173		
Reading for Concepts E																							173		
Reading for Concepts F																							173		
Reading for Concepts G																							173		
Reading for Concepts H																							173		
<u>SRA Reading Laboratory</u>																							180		
SRA Lab IIIa																							180		
SRA Lab IIIb																							180		

SKILL AREA - TITLES	INTEREST LEVELS												DESCRIPTION PAGE NO.										
	K-R	1-2	3-4	5-6	7-8	9-12	K	R	P	1	2	3		4	5	6	7	8	9	10	11	12	
<u>System 80 Program</u>																							183
Learning Letter Names, Kit A	x	x																					183
Learning Letter Names, Kit B	x	x																					183
Developing Spelling Skills Kits A, B, C, D, E, F, G	x	x	x																				183
Reading Words in Context Kits A, B, C, D, E, F, G, H	x	x	x																				183
<u>T-Matic Filmstrips</u>																							192
Words and Phrases VCF-1 (20 Filmstrips)	x	x	x	x	x	x																	192
Words and Phrases VCF-2 (20 Filmstrips)	x	x	x	x	x	x																	192
Words and Phrases VCF-3 (20 Filmstrips)			x	x	x	x																	192
Words and Phrases VCF-4 (20 Filmstrips)					x	x																	192
Words and Phrases VCF-5 (20 Filmstrips)					x	x																	192
Words and Phrases VCF-6 (20 Filmstrips)					x	x																	192
Words and Phrases VCF-7 (20 Filmstrips)					x	x																	192
Words and Phrases VCF-8 (20 Filmstrips)					x	x																	192
Remedial Reading Filmstrips RRF-1 (20 Filmstrips)					x	x																	192

SKILL AREA - TERMS

Tachistoscope (Tach-X)

- Perceptual Readiness - Set 10
- Primary Letters - Set 12

EDL Sight Vocabulary:

- Set A
- Set B
- Set C
- Set D
- Set E
- Set F
- Set V-789
- Set V-1011

Looking at Words Series:

- Set A
- Set B
- Set C
- Set D
- Set E
- Set F

Tachomatic Words and Phrases

- Grade 1
- Grade 2
- Grade 3
- Grade 4
- Grade 5
- Grade 6

Teaching Typewriter Programs

- Animal Friends
- Discovering Colors
- Alphabet Progression

INTEREST LEVELS

K-R 1-2 3-4 5-6 7-8 9-12

- x x x x
- x x x x
- x x x x x
- x x x x x
- x x x x x
- x x x x x
- x x x x x
- x x x x x
- x x x x x
- x x x x x
- x x x x x

- x x x x x
- x x x x x
- x x x x x
- x x x x x
- x x x x x

- x x x x
- x x x x
- x x x x
- x x x x
- x x x x
- x x x x

x x x x

INSTRUCTIONAL LEVELS

K R P 1 2 3 4 5 6 7 8 9 10 11 12

- x x x
- x x x
- x
- x x
- x
- x x
- x
- x x x
- x x x
- x
- x x x x

- x
- x x
- x
- x x
- x
- x x

- x
- x x
- x
- x x
- x x
- x x

x x x x
x x x x
x x x x

SKILL AREA VOCABULARY

DES-
CRPTION
PAGE NO.

- 184
- 184
- 184
- 184
- 184
- 184
- 184
- 184
- 184
- 184
- 184
- 184
- 184
- 184
- 186
- 186
- 186
- 186
- 186
- 186
- 188
- 188
- 188
- 188

<u>SKILL AREA - TITLES</u>	<u>INTEREST LEVELS</u>	<u>INSTRUCTIONAL LEVELS</u>	<u>DES- CRIPTION PAGE NO.</u>
<u>Teaching Typewriter Programs can't</u>	K-R 1-2 3-4 5-6 7-8 9-12	K R P 1 2 3 4 5 6 7 8 9 10 11 12	188
Reading and Spelling (Beginners)	x	x x x	188
Reading and Spelling (Fun with words) - 2 Sets	x	x x x	188
Opposites - 10 Concepts - Multiple Choice	x	x x x x	188
<u>Webster Reading Clinic</u>			197
The Magic World of Dr. Spello	x	x x x x x	197
Reading Skill Cards	x	x	197
New Webster Word Wheels	x	x x x x x	197
The Everyreader Series	x	x x x x x	197
Group Word Teaching Game	x	x x x x x	197
Basic Sight Vocabulary Cards	x	x x x x x	197
<u>Flash-X Programs</u>			138
Set X-1 Readiness Pictures	x	x x x x x	138
Set X-2 Primary Recognition	x	x x x x x	138
Set X-5 Sight Vocabulary	x	x x x x	138
Set X-6 Sight Vocabulary	x	x x x x	138
Set X-10 Sight Vocabulary	x	x x x x	138
Set X-12 Spelling Level 2	x	x	138
Set X-13 Spelling Level 3	x	x	138
Set X-14 Spelling Level 4	x	x	138
<u>Language Master Cards</u>			147
Building Basic English A	x	x x x x x x	147
Building Basic English B	x	x x x x x x	147

<p><u>DES-</u> <u>CRIFITION</u> <u>PAGE NO.</u></p>	
<p><u>INSTRUCTIONAL LEVELS</u> K R P 1 2 3 4 5 6 7 8 9 10 11 12</p>	
<p><u>INTEREST LEVELS</u> K-R 1-2 3-4 5-6 7-8 9-12</p>	
<p><u>SKILL AREA - TITLES</u></p>	

ADULT READERS

Workers in the Sky
"Send for Red!"
Mystery of the Mountains
Second Chance
A Race To Remember
Valley of 10,000 Smokes

Santa Fe Traders
Men Who Dare the Sea
Guides to Adventure
First at the Finish
"I Fell 18,000 Feet"
What's on the Moon?

Skills Covered: General

Vendor Code: 41

Interest Level: Senior

Non-Consumable

Instructional Level: 1-4

Approximate Price: \$30.00 - Teacher Manual: \$10.00

Description: Core materials that may be used to introduce or reinforce basic reading for the functionally illiterate or the adolescent in need of remedial training. Short, practical exercises after major stories develop comprehension and word attack skills and promote vocabulary building.

BARNELL-LOFT SPECIFIC SKILL SERIES

Drawing Conclusions (A-E)
Following Directions (A-F)
Getting the Facts (A-F)
Getting the Main Idea (A-E)

Locating the Answer (A-F)
Using the Context (A-F)
Working with Sounds (A-D)

Skills Covered: Comprehension - Word Analysis (Phonics)

Vendor Code: 5

Interest Levels: Elementary, Junior High, Senior High

Non-Consumable

Instructional Levels: 1-6

Approximate Price: \$.90 each, Specimen Set \$35.75

Description: These books teach specific reading skills. They may be purchased in quantity needed or in the Specimen Set which includes one booklet each of the books in this series. Worksheets are available and additional answer keys.

BARNELL-LOFT SPECIFIC SKILL SERIES

Getting the Facts A
Getting the Facts B
Getting the Facts C
Getting the Facts D
Getting the Facts E
Getting the Facts F

Skills Covered: Comprehension (Getting the Facts)

Vendor Code: 5

Interest Levels: Elementary, Junior High, Senior High

Non-Consumable

Instructional Levels: 1-6

Approximate Price: \$.90 each., Specimen Set \$35.75

Description: These books teach specific reading skills. They may be purchased in quantity needed or in the Specimen Set which includes one booklet each of the books in this series. Worksheets are available and additional answer keys.

BARNELL-LOFT SPECIFIC SKILL SERIES

Working with Sounds A
Working with Sounds B
Working with Sounds C
Working with Sounds D

Skills covered: Word Analysis (Phonics)(Working with Sounds) Vendor Code: 5

Interest Levels: Elementary, Junior High, Senior High Non-Consumable

Instructional Levels: 1-4

Approximate Price: \$.90 each., Specimen Set \$35.75

Description: These books teach specific reading skills. They may be purchased in quantity needed or in the Specimen Set which includes one booklet each of the books in this series. Worksheets are available and additional answer keys.

BARNELL-LOFT SPECIFIC SKILL SERIES

Using the Context A
Using the Context B
Using the Context C
Using the Context D
Using the Context E
Using the Context F

Skills Covered: Comprehension (Using the Context) Vendor Code: 5

Interest Levels: Elementary, Junior High, Senior High Non-Consumable

Instructional Levels: 1-6

Approximate Price: \$.90 each., Specimen Set \$35.75

Description: These books teach specific reading skills. They may be purchased in quantity needed or in the Specimen Set which includes one booklet each of the books in this series. Worksheets are available and additional answer sheets.

BARNELL-LOFT SPECIFIC SKILL SERIES

Locating the Answer A
Locating the Answer B
Locating the Answer C
Locating the Answer D
Locating the Answer E
Locating the Answer F

Skills Covered: Comprehension (Locating the Answer)

Vendor Code: 5

Interest Levels: Elementary, Junior High, Senior High

Non-Consumable

Instructional Levels: 1-6

Approximate Price: \$.90 each., Specimen Set \$35.75

Description: These books teach specific reading skills. They may be purchased in quantity needed or in the Specimen Set which includes one booklet each of the books in this series. Worksheets are available and additional answer keys.

BARNELL-LOFT SPECIFIC SKILL SERIES

Following Directions A
Following Directions B
Following Directions C
Following Directions D
Following Directions E
Following Directions F

Skills Covered: Comprehension (Following Directions)

Vendor Code: 5

Interest Levels: Elementary, Junior High, Senior High

Non-Consumable

Instructional Levels: 1-6

Approximate Price: \$.90 each., Specimen Set \$35.75

Description: These books teach specific reading skills. They may be purchased in quantity needed or in the Specimen Set which includes one booklet each of the books in this series. Worksheets are available and additional answer keys.

BARNELL-LOFT SPECIFIC SKILL SERIES

Getting the Main Idea A
Getting the Main Idea B
Getting the Main Idea C
Getting the Main Idea D
Getting the Main Idea E

Skills Covered: Getting the Main Idea (Comprehension)

Vendor Code: 5

Interest Levels: Elementary, Junior High, Senior High

Non-Consumable

Instructional Levels: 1-5

Approximate Price: \$.90 each., Specimen Set \$35.75

Description: These books teach specific reading skills. They may be purchased in quantity or in the Specimen Set which includes one booklet each of the books in this series. Worksheets are available and additional answer keys.

BARNELL-LOFT SPECIFIC SKILL SERIES

Drawing Conclusions A
Drawing Conclusions B
Drawing Conclusions C
Drawing Conclusions D

Skills Covered: Comprehension (Drawing Conclusions)

Vendor Code: 5

Interest Levels: Elementary, Junior High, Senior High

Non-Consumable

Instructional Levels: 1-4

Approximate Price: \$.90 each., Comp. Specimen Set \$35.75

Description: These books teach specific reading skills. They may be purchased in quantity needed or in the Specimen Set which includes one booklet each of the books in this series. Worksheets are available and additional answer keys.

BE A BETTER READER SERIES

Be A Better Reader I
Be A Better Reader II
Be A Better Reader III
Be A Better Reader IV
Be A Better Reader V
Be A Better Reader VI

Skills Covered: Word Recognition, Vocabulary

Vendor Code: 39

Interest Levels: Junior High Senior High

Non-Consumable

Instructional Levels: 7-12

Approximate Price: \$1.95 each., Teacher Edition: I & II - \$1.92
III - VI - .79

Description: These books (instructional levels seven through twelve) develop phonics, syllabication, rapid and critical reading, use and meaning prefixes and suffixes, location of information and vocabulary development. The texts develop approaches and skills in reading in the special subject fields of literature, social studies, science and mathematics.

BE A BETTER READER SERIES

Be A Better Reader, Book A
Be A Better Reader, Book B
Be A Better Reader, Book C

Skills Covered: Word Recognition, Vocabulary

Vendor Code: 39

Interest Levels: Junior High, Senior High

Non-Consumable

Instructional Levels: 4-6

Approximate Price: \$1.50 each., Teacher Editions Available - \$1.62 each

Description: These books develop phonics, syllabication, rapid and critical reading, use and meaning of prefixes and suffixes, location of information, and vocabulary development. The texts develop approaches and skills in reading in the special subject fields of literature, social studies, science, and mathematics.

BETTER READING BOOKS

Better Reading, Book 1
Better Reading, Book 2
Better Reading, Book 3
Reading Progress Folder (Pkg. of 20)
Instructor's Guide

Skills Covered: Rate - Comprehension

Vendor Code: 43

Interest Levels: Junior High, Senior High

Non-Consumable

Instructional Levels: 5.0 - 10.9

Approximate Price: Books 1, 2, 3 - \$2.85 each
Reading Progress Folders (Pkg. of 20) - \$3.60 Package
Instructors Guide - .55

Description: Twenty reading selections of literary quality in each volume. Comprehension and vocabulary checks with each selection. Answer keys in Progress Folders. One Better Reading Book and one Reading Progress Guide recommended for each student.

BOWMAR READING INCENTIVE PROGRAM

Karting
The Mighty Midgets
Slot Car Racing
Motorcycles
Drag Racing
Teen Fair

Horses
Surfing
Drag Racing - Funny Cars
Dune Buggies
Dune Buggy Racing
Custom Cars

Skills Covered: Independent Reading

Vendor Code: 7

Interest Levels: Junior High, Senior High

Non-Consumable

Instructional Levels: 2-3

Approximate Price: Paperbound book - \$2.60 each
Library " book - 3.25 each

Description: Series of independent readers designed specifically for young adults.

BOWMAR READING INCENTIVE PROGRAM - MULTI-MEDIA KIT

Skills Covered: Independent Reading

Vendor Code: 7

Interest Levels: Junior High, Senior High

Non-Consumable

Instructional Levels: 2-3

Approximate Price: \$30.00

Description: Each kit includes 10 soft cover books of one title and accompanying 7" LP Record or Cassette (tape) and filmstrip.

BUILDING READING SKILLS SERIES

Speedboat Book
Streamliner Book
Jet Plane Book

Rocket Book
Atomic Submarine Book
Space Ship Book

Skills Covered: General with emphasis on phonics

Vendor Code: 31

Interest Levels: Elementary

Non-Consumable

Instructional Levels: 1-6

Approximate Price: \$.90 each., Teacher Edition - \$1.20

Description: A series designed to be used with any basic reader program. It presents a strong developmental, reinforcement type of program. Phonics methods are used in conjunction with the teaching of sight vocabulary, structural analysis, and vocabulary building.

Phonetic practice is maintained in a context of interest rather than by drill on isolated words.

The series includes Skill Builder Cards and multicolored Teacher's Phonics Skill Builder Cards for use with Levels 1-3.

CHECKERED FLAG LEARNING SYSTEM

Audio-Visual Kit A
Audio-Visual Kit B

Skills Covered: Independent

Vendor Code: 19

Interest Levels: Elementary, Junior High, Senior High

Non-Consumable

Instructional Levels: 2-5

Approximate Price: Kit A - List \$102.40
Net 76.80

Kit B - (without magnetic tapes)
List - \$ 57.60
Net 43.20

Description: Kit A is for use with texts in the Checkered Flag Classroom Reading Kit A. It contains four color filmstrips, four LP records, four magnetic tapes, and a teacher's guide.

Audio-Visual Kit B contains four sound-films presentations to provide background for Checkered Flag Classroom Reading Kit B.

CHECKERED FLAG LEARNING SYSTEM

Classroom Reading Kit A
Wheels (2.4 reading level)
Riddler (2.5 reading level)
Bearcat (2.5 reading level)
Smashup (2.6 reading level)

Classroom Reading Kit A
Scramble (3.0 reading level)
Flea (3.5 reading level)
Grand Prix (4.0 reading level)
500 (4.5 reading level)

Skills Covered: Independent Reading

Vendor Code: 19

Interest Levels: Elementary, Junior High, Senior High

Non-Consumable

Instructional Levels: 2-5

Approximate Price: Kits A & B - List - \$ 57.60 (6 readers of each)
Net - 43.20 title: teacher's manual included

Description: Kits containing high interest, low vocabulary reading material. The kits are multi-sensory motivation program for junior and senior high school students. Teachers manuals are supplied with each kit.

Each kit contains four different titles with six copies of each.

COMPREHENSION POWER SERIES

Controlled Reader, Set C-3
Controlled Reader, Set C-4
Controlled Reader, Set C-5
Controlled Reader, Set C-6
Controlled Reader, Set C-7-8

Skills Covered: Comprehension

Vendor Code: 47

Interest Levels: Elementary, Junior High, Senior High

Non-Consumable

Instructional Levels: 3-8

Approximate Price: \$87.50

Description: This series of 25 controlled reader filmstrips may be used in a teacher directed group of students to develop comprehension skills.

CONTROLLED READER FILMSTRIPS

Controlled Reader Set CR-AA
Controlled Reader Set CR-BA
Controlled Reader Set CR-CA
Controlled Reader Set CR-DA
Controlled Reader Set CR-EA
Controlled Reader Set CR-FA

Skills Covered: Comprehension - Rate

Vendor Code: 47

Interest Levels: Junior High Senior High

Non-Consumable

Instructional Levels: 1-6

Approximate Price: \$90.00

Description: High Interest stories to be used with students to build comprehension skills and/or reading rate.

CONTROLLED READER, JR.

Vendor Code: 47

Non-Consumable

Approximate Price: \$202.00

Description: Two or three suggested per lab. Comes with teacher's guide and carrying case.

CONQUESTS IN READING

Skills Covered: Word Analysis - Vocabulary - Spelling Vendor Code: 32

Interest Levels: Elementary, Junior High, Senior High Consumable

Instructional Levels: 2 - 6

Approximate Price: \$1.30

Description: Comprehensive single workbook remedial program in phonetic and structural word analysis skills and spelling. Exercises begin with consonant sound-symbol relationships and proceed through affixes. Exercises also include vocabulary development through reading in context and development of a limited sight vocabulary. Student text is 145 pages, 8 x 11", illustrated. Manual available. Although suggested by publisher for use in the middle grades through junior high, format would be acceptable at senior high level.

CONTROLLED READER FILMSTRIPS

CR-MT: Motility Training	CR-E (one album)
CR-AD: Accelerated Discrimination	CR-EE (one album)
CR-A (two albums)	CR-F (one album)
CR-B (two albums)	CR-FF (one album)
CR-C (two albums)	CR-GH (one album)
CR-D (one album)	CR-IJ (one album)
CR-DD (one album)	CR-JI (one album)

Skills Covered: Comprehension - Rate - Visual Discrimination Vendor Code: 47

Interest Levels: Non-Consumable

Instructional Levels: K-10

Approximate Price: CR-MT - \$52.50 CR-A through CR-IJ - \$87.50 each
CR-AD - 32.00 CR-JI - 85.50

Description: Sets of graded story selection which contain both fact and fiction. The stories have a high interest level at low reading levels. The vocabulary is cumulative, therefore it is recommended that the student progress through the album in a sequential manner.

CONTROLLED READER (LARGE)

Vendor Code: 47

Non-Consumable

Approximate Price: \$275.00

Description: One suggested per lab. Comes with teacher's guide and carrying case.

During Controlled Reader training, a moving slot travels across the screen from left to right, covering and uncovering reading material as it goes. All eyes are on the screen, so, with no chance to look back, the students must be "on their toes" visually and mentally. The moving slot makes possible improvements in visual mobility and coordination. Directional attack improves as the reader develops an economy of fixations, makes fewer regressions, thus broadening his span of recognition. Comprehension improves as the reader becomes more comfortable visually and more proficient perceptually. Group training is provided with the EDL Controlled Reader; individual or team practice is carried out with the Controlled Reader, Jr.

CRAIG READERS

Skills Covered: General

Vendor Code: 13

Interest Levels: K-12

Non-Consumable

Instructional Levels: K-12

Approximate Price: \$229.95

Description: The Craig Reader is designed to help each student improve reading comprehension and increase reading efficiency at his own individual rate.

CRAIG READER PROGRAMS

Perception I, II, III (16 lessons each)
Programs:

- C (30 lessons)
- C-1 (32 lessons)
- C-2 (30 lessons)
- C-3 (30 lessons)
- C-4 (35 lessons)
- C-5 (40 lessons)

Reading Skills I
 Roots I; Roots II
 Program Vocabulary - Preview - Read
 Reading Program A
 Reading Program B

Skills Covered: Perceptual Development,- Vocabulary - Comprehension

Vendor Code: 13

Interest Levels: K-Adult

Non-Consumable

Instructional Levels: K-12

Approximate Price:

Perception I, II, III.- \$15.00
 Reading Skills I - Soon Available
 Roots I/Roots II - Soon Available
 Program V-P-R ----- \$39.50
 Reading Program A - \$49.50
 Reading Program B - \$76.00

Program C \$32.00
 Program Cw1 - 30.00
 Program C-2 - 30.00
 Program C-3 - 35.00
 Program C-4 - 30.00
 Program C-5 - 40.00

DECODING FOR READING

Skills Covered: General

Vendor Code: 33

Interest Levels: Elementary, Junior High, Senior High

Consumable

Instructional Levels: 4-8

Approximate Price: \$135.00

Description: An audio instructional program for students who failed to develop the basic reading skills in the primary grades. Consists of two read-along books with 16 LP records.

DEEP SEA ADVENTURE SERIES

The Sea Hunt
Treasure Under the Sea
Submarine Rescue
The Pearl Divers

Frogmen in Action
Danger Below
Whale Hunt
Rocket Divers

Skills Covered: Independent Reading ~ Comprehension

Vendor Code: 19

Interest Levels: Grades 3-10

Non-Consumable

Instructional Levels: 1.8 - 5.0

Approximate Price: First 3 titles - \$1.65 each
Last 5 titles - 1.80 each
Teachers Manual- .75 each

Description: Adventure stories of the sea. Science related. Oceanography. High interest, low readability. Suitable for supplementary reading. Vocabulary included in student edition.

DETECT TACTILE

Skills Covered: Perceptual Development

Vendor Code: 43

Interest Levels: K-2

Non-Consumable

Instructional Levels: K-2

Approximate Price: \$45.00

Replacement workbooks - 3-951 - \$.60
Replacement workbooks - 3-952 - .85
Replacement workbooks - 3-953 - .75

Description: The Detect Tactile program consists of five sets of various plastic forms, five detect game boards, three student workbooks, and a teacher's handbook. The Detect Tactile teaches major concepts and specific skills. The program comprises three levels of work, to which three workbooks - level 1, level 2, level 3, correspond.

DETECT VISUAL PROGRAM

Skills Covered: Visual Discrimination

Vendor Code: 43

Interest Level: Elementary

Workbooks - Consumable

Instructional Levels: K-3

Transparencies
and Projector- Non-Consumable

Approximate Price: Total Detect - \$258.00
Level A Workbook .57
Level B Workbook .57

Description: A sensorimotor approach to visual discrimination. The total program consists of 136 transparencies for all three levels. The transparencies with an overhead projector and the opta adapter use the tachistoscopic method of presentation. This program is totally group oriented.

DIMENSIONS IN READING

An American Album

Skills Covered: Comprehension

Vendor Code: 43

Interest Levels: Junior High and Senior High

Non-Consumable

Instructional Levels: 3.0 - 8.9

Approximate Price: Kit - \$67.50 Teacher Handbook - \$.40

Description: Anecdotal history of America from Columbus to Kennedy, Three hundred (300) stories at six reading levels. A comprehension check is provided at the end of each story.

DOLCH READERS

Big, Bigger, Biggest
Dog Pals
Friendly Birds
I Like Cats
In the Woods

Monkey Friends
On the Farm
Some are Small
Tommy's Pets
Zoo Is Home

Once There Was a Cat
Once There Was a Rabbit
Once There Was an Elephant
Once There Was a Monkey
Once There Was a Bear
Once There Was a Dog

Skills Covered: Independent Readers

Vendor Code: 21

Interest Levels: 1-4

Non-Consumable

Instructional Levels: 1

Approximate Price: \$2.00 each title

Description: Independent Readers designed for the earliest level of independence. Each book contains words taken from the easiest half of the Dolch 220 word list and the 95 most common nouns, for a total of 205 words.

DR. SPELLIO, 2nd Edition

Skills Covered: General

Vendor Code: 32

Interest Levels: 4-9

Consumable

Instructional Levels: 3-6

Approximate Price: Pupil's Workbook - \$.93
Teacher Edition - 1.23

Description: A corrective phonics and spelling skill program including sounding consonants, vowels, blends, digraphs, silent letter combinations, compound words, syllabication, accentuation, diacritical markings, and affixes..

E.D.L. WORD CLUES

Book G
Book H
Book I
Book J
Book K
Book L

Skills Covered: Vocabulary

Vendor Code: 47

Interest Levels: Junior High, Senior High

Consumable

Instructional Levels:

Approximate Price: \$2.20

Description: A vocabulary improvement series of 30 lessons within one book with programmed format.

FIRST EXPERIENCES WITH VOWELS AND CONSONANTS

Instructo - First Experience with Vowels and Consonants

Skills Covered: Phonics

Vendor Code: 15

Interest Levels: Elementary

Non-Consumable

Instructional Levels: 1-6

Approximate Price: \$79.95

Description: Complete multi-sensory program including first experiences with vowels and first experiences with consonants. Each kit may be purchased separately Complete teachers' manuals and spirit duplicating masters are included. Available through school supply catalogs.

FILMSTRIP PROJECTOR

Victor Soundview Filmstrip Projector, Model PB 65
Projector Carrying Case
9 Ft. Pushbutton Cable
25 Ft. Extension Cable for Pushbutton

Vendor Code:
On Bid.

Non-Consumable

Approximate Price: Projector - \$38.00
Carrying Case - 10.95
Pushbutton Cable - 4.20
Extension Cable - 3.85

FLANNEL BOARD LETTERS

Manuscript Letters #360

Interest Levels: Elementary

Vendor Code: 26

Non-Consumable

Approximate Price: \$7.50 per set

Description: For use with individual flannel boards, Three sets recommended

FLANNEL BOARDS

For individual use

Interest Levels: Elementary

Vendor Code: 26

Instructional Levels: Elementary

Non-Consumable

Approximate Price: \$.50 each

Description: One dozen individual boards recommended.

FLASH-X HAND TACHISTOSCOPE

Skills Covered: Concentration - Perception

Vendor Code: 47

Interest Levels: Elementary, Junior High, Senior High

Non-Consumable

Instructional Levels: K-12

Approximate Price: \$7.20

Description: A hand tachistoscope operated and checked by the student. Through timed exposure, of materials the student learns to concentrate, builds speed and accuracy of perception, and learns to retain material in a more orderly fashion.

FLASH-X PROGRAMS

Set X-1 - Readiness Pictures

Set X-6 - Sight Vocabulary

Set X-2 - Primary Recognition

Set X-10 - Sight Vocabulary

Set X-3 - Basic Accuracy - Numbers

Set X-12 - Spelling Level 2

Set X-4 - Basic Accuracy - Letters

Set X-13 - Spelling Level 3

Set X-5 - Sight Vocabulary

Set X-14 - Spelling Level 4

Skills Covered: Sight Vocabulary - Spelling -
Letter and Number Recognition

Vendor Code: 47

Interest Levels: Elementary, Junior High, Senior High

Non-Consumable

Instructional Levels: 1-12

Approximate Price: \$3.60 each set

Description: Flash-X drills are ideal for students who need extra practice in seeing skills and/or reinforcement with numbers, letters, and sight vocabulary as well as spelling.

FROSTIG DEVELOPMENT PROGRAM

Frostig Beginning Pictures and Patterns
Frostig Intermediate Pictures and Patterns
Frostig Advanced Pictures and Patterns
Teacher's Guides for each

Skills Covered: Perceptual Development

Vendor Code: 20

Interest Levels: K - 3

Consumable

Instructional Levels: K - 3

Approximate Price: Beginning Pictures & Patterns - \$.81
Teacher's Guide 1.65
Intermediate Pictures & " .90
Teacher's Guide 1.65
Advanced Pictures & Patterns .99
Teacher's Guide 1.65

Description: A workbook program which consists of Beginning Pictures and Patterns, Intermediate Pictures and Patterns, and Advanced Pictures and Patterns. Teacher's Guides are available for each area. (Recommend consumption.)

FROSTIG PROGRAM BOX

Ditto Masters
Teacher's Guide

Skills Covered: Perceptual Development

Vendor Code: 20

Interest Levels: Elementary

Instructional Levels: K - 3

Approximate Price: \$98.62

Description: The Program Box contains 359 Ditto Masters for five Visual Perception Areas. (teacher's guide included). Areas covered are: Visual-Motor Coordination, Perceptual Consistency, Figure-Ground, Spatial Relationships, and Position in Space.

FROSTIG TEST MATERIALS

Frostig Test Specimen Set
Frostig Test Booklet

Skills Covered: Testing

Vendor Code: 20

Interest Levels: Elementary

Consumable

Instructional Levels: Elementary

Approximate Price: Test Specimen Set - \$ 5.00
Test Booklet (single copy) - .60
Test booklet (set of 25) - 11.25

Description: The Specimen Set includes: 1 Administration and Scoring Manual, 1 Test Booklet, 3 Test Scoring Keys, 1 Test Monograph, 11 Test Demonstration Cards.

GATES PEARDON READING EXERCISES

Introductory, Level A	Elementary, RD (Can You Remember Details)
Introductory, Level B	Elementary, FD (Can You Follow Directions)
Preparatory, Level A	Intermediate, SA, FD, RD
Preparatory, Level B	Advanced, SA, FD, RD
Elementary, SA (Story About)	

Skills Covered: General.

Vendor Code: 49

Interest Levels: Elementary, Junior High

Non-Consumable

Instructional Levels: 1-8

Approximate Price: Introductory & Preparatory A & B - \$.45 each
Elementary, Intermediate, Adv. SA, RD, FD - \$.50 each
Record Sheets - \$1.10 (per 35)
Remedial Reading Ass't. - \$21.50

Description: Thirteen illustrated reading booklets ideally suited for developmental and remedial use. The booklets provide more than 360 short reading exercises followed by questions that relate to the skills stressed in the exercises.

A special assortment is available for teachers doing remedial work over a range of grades. They offer a continual measurement of the below-average reader.

GATEWAY SERIES, LEVEL THREE ANTHOLOGIES

Rebels and Regulars
People in Poetry
Something Strange
Ways of Justice

Skills Covered: General.

Vendor Code: 33

Interest Levels: Junior High, Senior High

Non-Consumable

Instructional Levels: 6-12

Approximate Price: \$1.70 each

Description: Series contains four soft-back books listed above. Teacher manual is available, also slides, tests on spirit masters, and record album.

HEADSETS (8) with Junction Box

Newcomb EDEB-8 Item 6C
8 Headsets with Junction Box

Vendor Code: 4

Non-Consumable

Approximate Price: \$36.60

HOFFMAN READER PROGRAMS

Primary Achievement Units (10 albums per unit) - 6 units
3rd Level Achievement Units (10 albums per unit) - 3 units
4th Level Achievement Units (10 albums per unit) - 3 units
5th Level Achievement Units (10 albums per unit) - 3 units
6th Level Achievement Units (10 albums per unit) - 3 units

Skills Covered: Word Attack, Structural Analysis,
Comprehension

Vendor Code: 12

Interest Levels: Elementary, Junior High

Non-Consumable

Instructional Levels: K-6

Approximate Price: Primary Units - \$ 99.00 each unit
3rd, 4th, 5th, 6th - 125.00 each unit
Work Pads - .35 each
Encore Library 19.95 each

Description: The Primary Series - Audio-visual programs are structured to prevent reading failure related to deficits in language. Lessons: 1) introduce sound; 2) discriminate between sound and other sounds, etc.

Work pads accompany each program in each unit.

An encore library accompanies each program in 3rd, 4th, 5th, and 6th achievement units.

HOFFMAN READER - MARK IV AV PROJECTOR

MX-200 Headset with Air-Cushion - Speaker
CC-4 Jackbox
CC-4V Jackbox
CC-12 Jackbox

Skills Covered: Comprehension

Vendor Code: 12

Non-Consumable

<u>Approximate Price:</u>	Reader \$389.00	Jackboxes - CC-4	\$ 4.95
	Headset 6.95	CC-4V	6.50
	Speaker 16.33	CC-8	7.95
		CC-12	8.95

Description: The Hoffman Reader is an audio and visual teaching machine with child operated programs. The programs emphasize the comprehension skills.

HOW TO STUDY

How to Study 5-1238
Teacher's Manual 5-1237
Study Habits Checklist 5-1235
Administrator's Manual for Checklist

Skills Covered: Study Skills

Vendor Code: 43

Interest Level: Senior High

Non-Consumable

Instructional Levels: 9 - 12

Approximate Price: \$1.95 per book - \$.50 instructor's manual

Description: An activity for individual or class use. Designed to help students whose study habits might be improved. Will acquaint them with study skills and habits that can improve the quality and efficiency of their work.

The Study Habits Checklist helps students determine their assets and weaknesses.

IDEAL LISTEN-LOOK-LEARN READING TAPES AND WORKBOOKS

Reading Readiness Tapes (16 lessons, worksheets)
Classification - Opposites - Sequence Tapes (10 lessons)
Initial and Final Consonant Tapes (20 lessons)
Blends and Digraphs (10 lessons)
Vowel Tapes (20 lessons)
Vowel Enrichment (20 lessons)
Syllable Rule-Accent Clues (16 lessons)

Skills Covered: Structural Analysis, Readiness,
Comprehension

Vendor Code: 15

Interest Levels: Elementary, Junior High

Non-Consumable

Instructional Levels: K-6

Approximate Price: All prices are cassettes -
Reading Readiness - \$48.00
Classification - Opposites - Sequence - 30.00
Initial and Final Consonants - 60.00
Blends and Digraphs - 30.00
Vowel Tapes - 60.00
Vowel Enrichment - 60.00
Syllable Rule-Accent Clues - 48.00

Description: The Ideal Tapes were designed for use in: Basic instruction, enrichment, remedial work, and review.

JIM FOREST READERS

Jim Forest and Ranger Don
Jim Forest and the Trapper
Jim Forest and the Ghost Town
Jim Forest and the Bandits
Jim Forest and Lightening

Skills Covered: Independent Reading

Vendor Code: 19

Interest Levels: Elementary

Non-Consumable

Instructional Levels: 1.7 - 1.9

Approximate Price: \$1.70 each

Description: Adventure series related to science, social studies, and conservation.

KALEIDOSCOPE OF SKILLS

Entering Grade 5 -
Book 5-1 Red/Silver
Book 5-2 Gold
Book 5-3 Lavender
Book 5-4 Olive

Entering Grade 6 -
Book 6-1 Orange/Aqua
Book 6-2 Tan
Book 6-3 Purple
Book 6-4 Lime

Entering Grade 7 -
Book 7-1 Rust/Blue
Book 7-2 Yellow
Book 7-3 Violet
Book 7-4 Green

Skills Covered: General

Vendor Code: 43

Interest Levels: Junior High, Senior High

Non-Consumable

Instructional Levels: 5, 6, 7

Approximate Price: Entering Grade 5 - Complete Set (4 books) - \$5.00
Entering Grade 6 - Complete Set (4 books) - \$5.00
Entering Grade 7 - Complete Set (4 books) - \$5.00
Teacher's Handbook - .25 each set

Description: A self study program, soft-cover workbooks, designed for the average student to develop and apply intermediate skills. Materials are high interest and cover a wide range.

The full program requires 4 workbooks per student per year. Recommended for readers having no specific deficiencies reading at levels 5, 6, 7 or as a follow-up material to remediation activities.

LANGUAGE MASTER

Language Master

Vendor Code: 12

Non-Consumable

Approximate Price: \$250.00

Description: Two (2) per reading room suggested.

LANGUAGE MASTER PROGRAMS

Blank Cards
Building Basic English A
Building Basic English B

Skills Covered: Vocabulary - Phonics

Vendor Code: 12

Interest Levels: Elementary, Junior High, Senior High

Non-Consumable

Instructional Levels: Elementary, Junior High

Approximate Price: Blank Cards - \$ 6.00 per 100
Building Basic English A - 56.00
Building Basic English B - 135.00

Description: Building Basic English, Set A, includes Noun and Everyday Things and 150 blank cards. Building Basic English, Set B, includes the 3 phonics programs, and 90 blank cards.

LANGUAGE MASTER PROGRAMS

Language Master Cards

- A. Blank Cards
- B. Phonics Program
 - 1. Sound Blending and Beginning Phonetic Skills, Set I
 - 2. Irregular Phonetic Sounds, Set II
 - 3. Word Building and Word Analysis Technique
- C. Word Picture Program
 - 1. Nouns and Everyday Things
 - 2. Verbs/Action Words
 - 3. Basic Concepts

Skills Covered: Vocabulary, Phonics

Vendor Code: 12

Interest Levels: Elementary, Junior High, Senior High

Instructional Levels: Elementary

Approximate Price: Blank Cards - \$ 6.00 per 100
 Phonics Program I, II, III - 35.00 each
 Word Picture Program I, II, III - 35.00 each

Description: The Language Master Cards emphasize word attack, structural analysis, and word meaning skills.

LEARNING TO READ WHILE LEARNING TO LEARN

The Purple Snail	Operation Phoenix	Hundred Milers
Happy the Hippo	Viceroy's Daughter	Racing the Salt
The Peculiar Lawn Mower	Behind the Scenes	Deadline for Time
Pedro's Secret	Rescue on the Mountain	The Big Break
Dognappers	A Place for Joe	Julius Caesar
Loud and Clear	Chilling Escape	

Skills Covered: General

Vendor Code: 10

Interest Levels: Elementary, Junior High

Non-Consumable

Instructional Levels: 4-9

Approximate Price: \$175.00

Description: A series of individualized readers for the intermediate and junior high school. The books have a high interest level and are boy oriented. They provide individualized vocabulary development and reading guidance, suited to a wide range of interests and reading skills. The books are listed in reading level sequence.

LEARNING TO THINK SERIES

Red Book
Blue Book
Green Book
Gold Book

Skills Covered: Critical Language Arts

Vendor Code: 43

Interest Levels: Elementary

Consumable

Instructional Levels: K-1

Approximate Price: Student Book - \$.85
Lesson Chart - 6.48
Teacher Manual - 1.00

Description: The Learning to Think Series, designed for grades K-1, presents material for young children that is designed to develop the mental skills necessary to a child's success in school. The lesson in this series present material that emphasized motor coordination, perception, reasoning, quantitative thinking, word fluency, verbal meaning, spatial thinking and memory. The number of books needed for any reading lab would depend on the number of children needing this type of approach since the workbooks are consumed and one is needed for every student.

LISTEN AND THINK SERIES

Listen and Think A-R	Listen and Think D	Listen and Think G
Listen and Think B	Listen and Think E	Listen and Think H
Listen and Think C	Listen and Think F	Listen and Think I

Skills Covered: Listening Skills

Vendor Code: 47

Interest Levels: Elementary, Junior High, Senior High

Non-Consumable

Instructional Levels: K-9

Approximate Price: \$98.00 Tapes., \$108.00 Cassette., \$.85 Workbooks

Description: Listen and Think is a developmental program designed to improve listening comprehension and to develop specific thinking skills necessary for good listening. Each lesson on tape opens with an attention getting situation which demonstrates the specific thinking skill to be learned. The narrator introduces the students to the skill being presented and emphasizes its value to the student. The student is then directed to the Activity Sheet or Lesson Book for an exercise requiring application of the skill. He returns to the tape for the correct answers and explanations.

Accompanying workbooks at each level are available for \$.85 each.

EYE AND EAR FUN SERIES

Eye and Ear Fun, Book 1
Eye and Ear Fun, Book 2
Eye and Ear Fun, Book 3
Eye and Ear Fun, Book 4

Skills Covered: Auditory

Vendor Code: 32

Interest Levels: Elementary

Consumable

Instructional Levels: 1-6

Approximate Price: \$.90 each

Description: A beginning supplementary reading program on the primer level. Exercises in workbook-type books build word attack skills. Recommended for older children with speech problems.

MERRILL REFRESHER PROGRAM OF LINGUISTIC READERS

Books A through D

Skills Covered: Phonics, Language Usage

Vendor Code: 34

Interest Levels: Junior High, Senior High

Non-Consumable

Instructional Levels: 7-12

Approximate Price: Book A - \$2.25 Book C - \$1.71 Teacher's Guide -
Book B - 1.71 Book D - 2.01 \$2.00

Description: Refresher program is designed for remedial use in elementary, junior high, senior high schools, and adult illiterates. It is useful with hyperactive, distractible, and students with perceptual problems.

Material uses a spelling pattern approach with no pictures. A teacher's guide is essential as it not only provides special testing procedures, but outlines method of presentation essential if best results are to be obtained.

LITERATURE SAMPLER

Skills Covered: Independent Reading

Vendor Code: 27

Interest Levels: Junior High, Senior High

Non-Consumable

Instructional Levels: 4-9

Approximate Price: \$60.00

Description: This laboratory previews 144 books (of 124 authors) from reading grade levels 4-9. Many of the books represented in the Sampler are available in paperback editions. Program contains:

- 144 Book Previews, 4 page folders, colorfully illustrated
- 144 Reading Aid Cards (Questions)
- 144 Discussion Cards (Answers)
- 1 Student Log
- Teacher's Guide

MACMILLAN READING SPECTRUM

Spectrum of Skills
Spectrum of Books

Skills Covered: Word Analysis, Vocabulary, Comprehension Vendor Code: 33

Interest Level: Junior High

Instructional Levels: 3.5 - 5.0

Approximate Prices: Spectrum of Skills - \$69.75
Spectrum of Books - 33.00

Descriptions The Spectrum of Skills consists of six booklets in three reading skills areas, word analysis, vocabulary development, and reading comprehension. There are 18 booklets in all, plus a Pupil Record Book and Teacher's Guide. The booklets are self-directing, self-correcting, and non-consumable. The Spectrum of Books consists of 30 children's books; the first set ranges in difficulty from second grade to sixth grade and the second set ranges from third grade to seventh grade.

MANPOWER AND NATURAL RESOURCES KIT

Skills Covered: General Vendor Code: 43

Interest Levels: Junior High, Senior High

Instructional Levels: 4.0 - 11.9

Approximate Price: \$67.50

Description: Reading selections from popular books and magazines. Designed as developmental reading guidance in vocational and technical material. Jobs covered are primarily masculine.

MCCALL CRABB SERIES

McCall Crabb, Books A through E

Skills Covered: General

Vendor Code: 49

Interest Levels: Elementary, Junior High, Senior High

Non-Consumable

Instructional Levels: 3-7

Approximate Price: \$.60 each

Description: Series consists of five booklets, each 75 lessons (selections with questions of multiple choice type) designed to help develop a rate of speed and power of comprehension exceeding that yielded by ordinary methods of teaching silent reading. Score sheets and keys are available - manual not included.

MERRILL LINGUISTIC READERS

Linguistic Reader 1
Linguistic Reader 2
Linguistic Reader 3

Linguistic Reader 4
Linguistic Reader 5
Linguistic Reader 6

Skills Covered: Comprehension

Vendor Code: 34

Interest Levels: Elementary

Non-Consumable

Instructional Levels: 1-6

<u>Approximate Price:</u>	Books 1 and 2	- \$.69	Teachers Edition Readers	
	Book 3	- .78	1 and 2	- \$.69
	Books 4 and 5	- 1.71	Teachers Edition Readers	
	Book 6	- 2.01	3	- .78
	Skills Book 1 and 2	- .45	Teachers Edition Readers	
	Skills Book 3	- .51	4 and 5	- .96
	Skills Books 4,5,6	- .60	Teachers Edition Readers	
			6	- 1.26

Description: A basic linguistic program for teaching through decoding in primary grades. Skills books to accompany these are available. Also teachers' annotated edition.

Some problem readers have had success with these when they could not read regular readers.

MERRILL MAINSTREAM

Courage Under Fire
Against the Odds
They Were First
In New Directions
People Like You

Skills Covered: Comprehension, Recreational Reading

Vendor Code: 34

Interest Levels: Junior High, Senior High

Non-Consumable

Instructional Levels: 4, 5, 6

Approximate Price: \$1.20 each book
.50 teacher's edition

Description: Paperback anthologies designed for reluctant readers in inner-city classrooms. Interesting stories, some by famous authors, that appeal to teen-agers.

MIAMI LINGUISTIC READERS

Biff and Tiff	Hot Corn Muffins!	Mark's Jet
Kit Kit and the Catfish	The Camping Trip	Matt and the Black Cat
Nat the Rat	The Magic Bean	B Is For Bicycle
Tug Duck and the Zuzz Bug	Chang's Shell	White Horse
The Sack Hut	Dick's Cat	The Man On the Penny
On the Rock in the Pond	Rumpelstiltskin	The Twin Mystery
The Picnic Ship	On Sunfish Island	

Skills Covered: General

Vendor Code: 25

Interest Levels: Elementary

Non-Consumable

Instructional Levels: PP-3

Approximate Price: \$.50 each

Description: The Miami Linguistic Readers were designed to teach beginning reading skills to culturally disadvantaged children and/or to those whose pre-school language was other than English.

MICHIGAN LANGUAGE PROGRAM

Skills Covered: Visual and Auditory Discrimination,
Speaking Skills

Vendor Code: 28

Interest Levels: Elementary

Consumable

Instructional Levels: 2-6

Approximate Price: Price information is available from the company upon request

Description: Michigan Language Program is well integrated with all facts of a language arts approach. While students are learning beginning visual discrimination, they are also acquiring auditory discrimination and beginning to learn spatial perception prior to writing. Program is individualized and self pacing, giving each learner the opportunity to proceed at his own rate. Students are also involved in a fluency training program to improve the spoken language. Information as to prices, etc., is available from the company upon request.

MICHIGAN TRACKING PROGRAM

Skills Covered: Visual Discrimination,
(Perceptual Development)

Vendor Code: 28

Interest Levels: Elementary

Consumable

Instructional Levels: 2-6

Approximate Price: Price information is available from the company upon request

Description: This program is designed for children and/or adults experiencing difficulty in discrimination and directional control. Information as to prices, etc., is available from the company upon request.

MORGAN BAY MYSTERY SERIES

Mystery of Morgan Castle	Mystery of the Missing Marlin
Mystery of the Marble Angel	Mystery of the Monk's Island
Mystery of the Midnight Visitor	Mystery of the Myrmidon's Journey
Mystery of the Musical Ghost	Mystery of Marauder's Gold

Skills Covered: Comprehension, Independent Reading

Vendor Code: 19

Interest Levels: Grades 4-10

Non-Consumable

Instructional Levels: 2.3 -4.1

Approximate Price: First 5 titles - \$1.80 each
Last 3 titles - 1.95 each
Teacher's Manual - .75 each

Description: Mystery stories of high interest - suitable for supplementary reading. Each has low readability levels and low vocabulary.

MOTT BASIC LANGUAGE SKILLS PROGRAM

Basic Language Skills
Book 1301
Book 1302
Book 1303
Book 1304
Book 1305
Book 1306

Skills Covered: Word Analysis

Vendor Code: 9

Interest Levels: Junior High, Senior High

Consumable

Instructional Levels: 1-3

Approximate Price: \$2.00 each, Teacher's Manual \$1.00

Description: A systematic programmed reading instruction series of skills taught in grades 1 through 9.

Teacher manual for the Semi-programmed series is \$1.00.

MOTT BASIC LANGUAGE SKILLS PROGRAMS

Basic Language Skills

Book 1307
Book 1308
Book 1309
Book 1310

Skills Covered: Vocabulary and Comprehension

Vendor Code: 9

Interest Levels: Junior High, Senior High

Consumable

Instructional Levels: R-P

Approximate Price: \$2.00 each, Teacher's Manual \$1.00 each

DESCRIPTION: A systematic programmed reading instruction series of skills taught in grades 1 through 9.

Teacher manual for the Semi-programmed series is \$1.00.

MOTT BASIC LANGUAGE SKILLS PROGRAM

Word Bank

Skills Covered: Vocabulary

Vendor Code: 9

Interest Levels: Junior High, Senior High

Consumable

Instructional Levels: R-P

Approximate Price: \$2.00

Description: The Mott Program builds basic vocabulary of 300 common nouns. It includes spelling tests for each unit, comprehension questions, and 12-25 common object word units.

MOTIVATION READERS

Blue Dog
The Flying Squirrels
The Almost Ghost

The Barking Cat
Better Than Gold
Three Green Men

Skills Covered: Independent Reading

Vendor Code: 30

Interest Levels: Elementary

Non-Consumable

Instructional Levels: 1-8

Approximate Price: \$2.00 each

Description: The Motivation Readers are written for marginal readers, emphasizing varied high interest content, vocabulary, and sentence structure that is easily understood for the grade level specified. Provides pupils controlled practice in reading to increase their basic reading abilities and overall interest in reading.

MYSTERY ADVENTURE SERIES

Mystery Adventure of the Talking Statues
Mystery Adventure of the Jeweled Ball
Mystery Adventure of Cave Four
Mystery Adventure of the Indian Burial Ground
Mystery Adventure at Longcliff Inn
Myster Adventure of the Smuggled Treasure

Special Editions:
Mystery Adventure Reader I
Mystery Adventure Reader II

Skills Covered: Independent Readers

Vendor Code: 6

Interest Levels: Junior High, Senior High

Non-Consumable

Instructional Levels: 2-6

Approximate Price: Mystery Adventure Series - \$2.60, Special Ed. - \$5.25 each
25% discount on orders of 6 or more

Description: Adventure and mystery stories recommended for supplementary and/or remedial reading. Each special edition combines three separate titles with special activity materials bound in one book. The Teacher's Guide, including skill development activities and lesson plans, are available with Special Editions.

NEW MODERN READING SKILL TEXTS

New Modern Reading Skill Texts - Books 1, 2, and 3

Skills Covered: General, Comprehension

Vendor Code: 34

Interest Levels: Junior High, Senior High

Consumable

Instructional Levels: 4-8

Approximate Price: \$1.00 each

Description: Series of skills books (paperbacks) designed for junior-senior high school use to develop skills in understanding, meaning, analysis, organization, and word analysis. Diagnostic tests for pre and post testing are included. Teacher's Editions are available.

NEW PRACTICE READERS

New Practice Readers - Books A through G

Skills Covered: Comprehension, Vocabulary

Vendor Code: 32

Interest Levels: Elementary, Junior High, Senior High

Non-Consumable

Instructional Levels: 2-8

Approximate Price: Books A and B - \$1.14 Answer Key - \$.30 each
Books C, D, and E - 1.23 T.M. for Series - .45
Books F and G - 1.26

Description: Graded readers providing short high-interest reading selections followed by comprehension and vocabulary exercises to gradually build reading skills.

NEW READING SKILL BUILDERS

Level 1	Level 4	Advanced Reading Skill Builder
Part I	Part I	Level 7
Part II	Part II	Book One
Level 1+	Level 5	Book Two
Part I	Part I	Level 8
Part II	Part II	Book Three
Level 2	Level 6	Book Four
Part I	Part I	
Part II	Part II	
Level 3		
Part I		
Part II		

Skills Covered: General

Vendor Code: 41

Interest Levels: Elementary, Junior High, Senior High

Non-Consumable

Instructional Levels: 1-8

Approximate Price: Level 1 and 1+ - \$.66 each
Levels 2 - 8 - .90 each

ON TARGET (READING FOR PLEASURE SERIES)

On Target
Top Flight
In Orbit

Skills Covered: Independent Reading

Vendor Code: 44

Interest Levels: Senior High

Non-Consumable

Instructional Levels: 5-6

Approximate Price: \$3.25 each

Description: Each book is a set of stories used for supplementary pleasure reading. Ten copies per lab are recommended.

OVERHEAD PROJECTOR

Bid Item #44

Overhead Projector, Standard 10 x 10 Platform
2100 Lumens c/w roll attachment
3M Classroom Model 66

Request from: Warehouse on Warehouse Requisition
Bessler Portascribe Modell G100AA - Overhead Projector

Non-Consumable

Approximate Price: \$97.00, \$57.39

PERCEPTION FILMSTRIPS

1. Developing Cognitive Skills for Young Learners (7 filmstrips)
2. Visual Perception Skills (7 filmstrips)
3. Developing Body Space Perceptual Motor Skills
(3 volume album, Teacher's Guide for each record included)

Skills Covered: Visual and Motor Perception

Vendor Code: 17

Interest Levels: Elementary

Non-Consumable

Instructional Levels: K-1

Approximate Price: Numbers 1 and 2 - \$49.00, Number 3 - \$14.94

Description: Skills Emphasized with Perception Filmstrips:

1. Grouping and Categorizing, Contrasts and Opposites, Relative Space and Size Relationships, Concept Ordering, Sequence of Ideas, Making Inferences, Judging Antecedents.

2. Visual Memory, Visual Motor Coordination, Visual Constancy, Visual Discrimination, Figure-Ground Perception, Visualization, Visual Matching

3. Appropriate games and exercises help child to sense himself in relation to place and space. Three albums, each with teacher's guide.

Volume 1: Demonstrates body in relational positions as in front, behind and alongside. Volume 2: Motor Skills - practice as well as space perception, directionality, and laterality. Volume 3: Games and exercises enable child to physically experience concepts such as front-back, over-under, left-right.

PETERSON HANDWRITING

- #38 - Basic Text - Improve Your Writing for Job Success
- #36 - Handwriting Legibility Kit for Young Adults (learner)
- #361 - Handwriting Legibility Kit for Young Adults (teacher)
Pupil Handwriting Kit - grades 7 and up

Writing Right in the Advanced Levels:

- Teacher's Handwriting Guide
- #18P - Colorgraph, Manuscript
- #15 - Handwriting Grading Scale, Cursive
- #2B - Wall Alphabet, Cursive
- #17 - Slant Reminders, package of 35
- #35 - The Common Sense Approach to Teaching Handwriting (methods)

Skills Covered: Handwriting

Vendor Code: 38

Interest Levels: Senior High/Junior High

Non-Consumable

Instructional Levels: 7-12

<u>Approximate Price:</u>	#38 - \$1.50	#2B - \$1.50
	#36 - .49	#17 - 1.50
	#361 - .74	#35 - 1.98
	#18P - .25	.30 - Pupil Handwriting Kit
	#15 - 1.25	1.50 - Teacher's Handwriting Guide

Description: "Peterson Handwriting" is a complete set for handwriting improvement at the secondary level. This handwriting unit is included due to content of the program and the format of the materials, which offer a variety of high-interest activities for students at the levels for which these materials are recommended.

PHONETIC READERS SERIES

Puss in Boots
Jack the Giant Killer
Jack and the Beanstalk

Aladdin and the Wonderful Lamp
Ali Baba and the Forty Thieves
Robinson Crusoe

Skills Covered: Phonetic Reader, Independent Reader

Vendor Code: 18

Interest Levels: Elementary

Non-Consumable

Instructional Levels: 2-4

Approximate Price: \$2.00 per set of 6

Description: Six small books offering well-known tales retold by author in phonetically regular words. The high-interest stories capture the student's attention and the use of phonetically regular words helps to improve reading ability. Stories increase in difficulty and each has numerous illustrations.

PHONETIC READING SERIES

Mac and Tab
The Tin Man
Al
Ben Bug

Ed
Ted
The Wig

Skills Covered: Independent Reading

Vendor Code: 18

Interest Levels: Elementary

Non-Consumable

Instructional Levels: 1

Approximate Price: Set of 10 - \$2.50

Description: Storybooks are to be used in conjunction with Primary Phonics, Workbook One. Each storybook contains a complete story with a plot to make early emphasis on Comprehension possible.

PHONICS IN A NUTSHELL

Skills Covered: Phonetic and Structural Analysis

Vendor Code: 16

Interest Levels: Elementary, Junior High, Senior High

Non-Consumable

Instructional Levels: 2-7

Approximate Price: Approximately \$140.00

Description: A set of nine filmstrips and accompanying records covering phonics, syllabication and fundamental word analysis concepts.

PHONICS IS FUN

Book 1

Book 2

Book 3

Skills Covered: Phonetic Analysis

Vendor Code: 36

Interest Levels: Elementary

Consumable

Instructional Levels: 1, 2, & 3

Description: "Phonics in Fun" emphasized Phonetic Analysis Skills and Structural Analysis Skills. Teacher manuals and keys are available.

PACSETTERS IN PERSONAL READING

The Fish Who Weren't Widdershins
Moon City Unwilling Witch
Thief in the Basement The Thousand Voices of Timothy Reese
Teacher Editions of each available

Skills Covered: Vocabulary, Critical Thinking and Interpretation Vendor Code: 30

Interest Levels: 3-8, Elementary, Junior High Language Arts Activities Non-Consumable

Instructional Levels: 3-8

Approximate Price: About \$3.25 each

Description: Pacesetters are high-interest, low readability readers to encourage individual language development in the areas of language arts.

PEABODY LANGUAGE DEVELOPMENT KIT

Kit P
Kit 1
Kit 2
Kit 3

Skills Covered: Language Development Vendor Code: 2

Interest Levels: K-4 Non-Consumable

Instructional Levels: K-4

Approximate Price: Kit P - \$145.00
 Kit 1 - 52.00
 Kit 2 - 65.00
 Kit 3 - 50.00

Description: Each kit contains 400-600 picture and word cards on heavy duty tag board, attractive hand puppets and teacher's manual. Individual kits contain additional materials appropriate for the various levels.

PHONICS WE USE SERIES

Book A
Book B
Book C
Book D
Book E
Book F
Book G

Skills Covered: Phonics

Vendor Code: 30

Interest Levels: Elementary, Junior High

Consumable

Instructional Levels: 1-7

Approximate Price: \$.75 each

Description: The Phonics We Use Series helps pupils associate written symbols with speech sounds. The structured sequence of instruction includes: 1) Concept introduction 2) Reinforcement through practice 3) Diagnostic testing and 4) Continuous review to maintain skills.

PHONICS WITH WRITE AND SEE

Phonics With Write and See, A
Phonics With Write and See, B

Skills Covered: Phonics

Vendor Code: 3

Interest Levels: Elementary

Consumable

Instructional Levels: 1-4

Approximate Price: Book A - 12 books per unit (sold in units) - \$11.50
Book B - 12 books per unit (sold in units) - 11.50
Teacher's edition for Book A and Book B - 1.75

Description: Phonics With Write and See is a self-correcting supplementary exercise materials for any systematic phonic or linguistic reading program.

Consumable materials: Each child in program needs an individual workbook.

The program is designed for use with remedial and enrichment classes.

PILOT LIBRARY IIa

Skills Covered: Comprehension, Vocabulary

Vendor Code: 43

Interest Levels: Elementary, Junior High, Senior High

Non-Consumable

Instructional Levels: 2-7

Approximate Price: \$59.55

Description: The Pilot Library Series is designed to bridge the gap between reading training and independent reading with short excerpts from noted literature. Each library contains seventy-two selections from full-length books to whet the reader's appetite and lead him to the original book.

PILOT LIBRARY IIb

Skills Covered: Comprehension, Vocabulary

Vendor Code: 43

Interest Levels: Elementary, Junior High, Senior High

Non-Consumable

Instructional Levels: 3-8

Approximate Price: \$59.95

Description: The Pilot Library Series is designed to bridge the gap between reading training and independent reading with short excerpts from noted literature. Each library contains seventy-two selections from full-length books to whet the reader's appetite and lead him to the original book..

PILOT LIBRARY IIC

Skills Covered: Comprehension, Vocabulary

Vendor Code: 43

Interest Levels: Junior High, Senior High

Non-Consumable

Instructional Levels: 4-9

Approximate Price: \$59.95

Description: The Pilot Library Series is designed to bridge the gap between reading training and independent reading with short excerpts from noted literature. Each library contains seventy-two selections from full-length books to whet the reader's appetite and lead him to the original book.

PILOT LIBRARY IIIB

Skills Covered: Comprehension, Vocabulary

Vendor Code: 43

Interest Levels: Senior High

Non-Consumable

Instructional Levels: 5-12

Approximate Price:

Description: The Pilot Library Series is designed to bridge the gap between reading training and independent reading with short excerpts from noted literature. Each library contains seventy-two selections from full length books to whet the reader's appetite and lead him to the original books.

PORTASCRIBE

Beseler Portascribe
Model G100AA - Overhead Projector

Approximate Price: \$57.39

Description: Request from: Warehouse on Warehouse Requisition

PRACTICE PADS

Practice Pad 1
Practice Pad 2
Practice Pad 3
Advanced Pad

Skills Covered: General

Vendor Code: 41

Interest Levels: Elementary

Consumable

Instructional Levels: 1-6

Approximate Price: Pads 1, 2, and 3 - \$.66 each
Advanced Pad - .84 each

Description: Practice Pads may be used in conjunction with - or independently of Reading Skill Builders to reinforce and extend basic skills. Each page is perforated and may be easily removed. The Teacher's Edition provides useful linguistic information and offer suggestions for auditory training, discussion topics and additional exercises.

PRIMARY PHONICS

Workbook One
Workbook Two

Skills Covered: Word Recognition

Vendor Code: 18

Interest Levels: Elementary

Consumable

Instructional Levels: 1-2

Approximate Price: \$1.00 each

Description: A structural approach to beginning reading. Workbook One uses the single consonants and the short vowels. Workbook Two uses the single consonants from Workbook One and introduces long vowels.

READING ATTAINMENT SYSTEM

Six Color Groups (20 selections each)

Red	Green
Orange	Blue
Brown	Purple

Skills Covered: General

Vendor Code: 23

Interest Levels: Junior High, Senior High

Non-Consumable

Instructional Levels: 4 - 5

Approximate Price: \$74.50 a set, record books - \$.40

Description: A self-study program of high-interest material geared to the adolescent. Selections are contemporary and drawn from the social and physical sciences. A total of 120 color-keyed graded reading selections, followed by a comprehension check; 120 skill cards including glossary and reading and word-attack exercises. Selections are identified on the basis of specific skills and the exercise questions are patterned to facilitate diagnosis. Material is self-scoring.

READING ATTAINMENT I

Skills Covered: General

Vendor Code: 23

Interest Levels: Junior High

Non-Consumable

Instructional Levels: 3.5 - 4.5

Approximate Price: Reading Attainment I - \$74.50

Student Record Books:	
1- 9	- .45
10-99	- .40
100-or more	- .35

Description: Reading Attainment is a self-directed individualized program containing 120 color-keyed graded selections. The contemporary selections include comprehension questions with matching skill cards used for developing vocabulary and reading skills. Manual and student record books are included with the kit.

PRIMARY PHONICS

Workbook One
Workbook Two

Skills Covered: Word Recognition

Vendor Code: 18

Interest Levels: Elementary

Consumable

Instructional Levels: 1-2

Approximate Price: \$1.00 each

Description: A structural approach to beginning reading. Workbook One uses the single consonants and the short vowels. Workbook Two uses the single consonants from Workbook One and introduces long vowels.

READING ATTAINMENT SYSTEM

Six Color Groups (20 selections each)

Red	Green
Orange	Blue
Brown	Purple

Skills Covered: General

Vendor Code: 23

Interest Levels: Junior High, Senior High

Non-Consumable

Instructional Levels: 4 - 5

Approximate Price: \$74.50 a set, record books - \$.40

Description: A self-study program of high-interest material geared to the adolescent. Selections are contemporary and drawn from the social and physical sciences. A total of 120 color-keyed graded reading selections, followed by a comprehension check; 120 skill cards including glossary and reading and word-attack exercises. Selections are identified on the basis of specific skills and the exercise questions are patterned to facilitate diagnosis. Material is self-scoring.

READING ATTAINMENT I

Skills Covered: General

Vendor Code: 23

Interest Levels: Junior High

Non-Consumable

Instructional Levels: 3.5 - 4.5

Approximate Price: Reading Attainment I - \$74.50

Student Record Books:	
1- 9	- .45
10-99	- .40
100-or more	- .35

Description: Reading Attainment is a self-directed individualized program containing 120 color-keyed graded selections. The contemporary selections include comprehension questions with matching skill cards used for developing vocabulary and reading skills. Manual and student record books are included with the kit.

READING ATTAINMENT II

Skills Covered: General

Vendor Code: 23

Interest Levels: Senior High

Non-Consumable

Instructional Levels: 4.5 - 6.0

Approximate Price: Reading Attainment II - \$74.50
Student Record Books:
1-9 - .45
10-99 - .40
100-or more - .35

Description: Reading Attainment is a self-directed individualized program containing 120 color-keyed grades selections. These contemporary selections include comprehension question with matching skill cards used for developing vocabulary and reading skills. Manual and student record books are included with the kit.

READING FOR CONCEPTS, A-H

Skills Covered: Comprehension, Vocabulary

Vendor Code: 32

Interest Levels: Junior High, Senior High

Non-Consumable

Instructional Levels: 2-9

Approximate Price: A-E - \$1.65 for soft \$3.00 for hard
F-H - 2.10 for soft 3.15 for hard
Teacher's guide - \$.60

Description: Set of eight books available in either soft or hard covers. Factual reading material pertinent to the learning areas of the total curriculum, critical reading, particularly drawing conclusions and making inferences.

READING DEVELOPMENT KITS

Kit A
Kit B
Kit C

Skills Covered: Comprehension

Vendor Code: 1

Interest Levels: Junior High, Senior High

Non-Consumable

Instructional Levels: 1-10

Approximate Price: \$56.00 per kit, manual \$1.00

Description: These editions are "specifically intended for adults in adult education and for younger students in need of literary training". On the basis of either the Informal Reading Development Inventory, or a standardized test, students are placed in the appropriate kit. Five lessons in critical reading at the beginning of each kit must be done before beginning the rest of the lessons in the kit. Then using a Reading Development Progress Record, the student can begin a lesson. The student's record book also includes keys to check answers.

READING FOR MEANING SERIES

Reading for Meaning, 4-12

Skills Covered: Comprehension, Study Skills

Vendor Code: 29

Interest Levels: Junior High, Senior High

Consumable

Instructional Levels: 4-12

Approximate Price: \$.90, Teacher's Guide 4-6 - \$.60,
Teacher's Manual 7-9 - .60

Description: A series of nine workbooks with directing emphasis toward development of comprehension, and study skills. Suitable for individual or group instruction.

READING FOR UNDERSTANDING SERIES

Reading for Understanding Laboratory, Junior Edition
Reading for Understanding Laboratory, General Edition
Reading for Understanding Laboratory, Senior Edition

Skills Covered: Critical Comprehension

Vendor Code: 43

Interest Levels: Elementary, Junior High, Senior High

Non-Consumable

Instructional Levels: 3 - 12

Approximate Price: \$56.00

Description: These developmental reading kits are useful in grades three through twelve for developing critical comprehension. The paragraphs are graded in difficulty and cover comprehension, reasoning, inference, interpretation, and meaning. Each kit contains 400 lesson cards, one placement test, a student record book, and forty answer booklets and a teacher's handbook.

ROYAL ROAD MINIATURE READERS

Pip the Pet Rabbit
Jill's Best Frock
The Picnic
The Robins

The Bulldog and the Kitten
The Swimming Lesson
The Kitten and the Stamps
The Cat and the Bed

Skills Covered: Independent Reading

Vendor Code: 18

Interest Levels:

Non-Consumable

Instructional Levels: PP-1

Approximate Price: \$1.00 per set of 10

Description: Eight sets of small 20-page "books" with primary print and large illustrations.

READINGTIME BOOKS

The Parade	Seven at One Blow
A Friend for Jenny	Rainy
Olly's Alligator	Scared Kitten
The New Boy	The Adventures of Polly Peters
Ted's Garden	The Princess of the Glass Hill
Three Billy Goats Gruff	Good-by, Tree
Something to Tell	Mr. Skinny Arms
The Big Whistle	Spiderlegs
I Like Cowboys	Where Were You When the Bell Rang?
That Smart Dog, Sam	And The Three Tailors
Spaceship of Your Own	Lonnie and the Flicker Family
Randy's Holiday	Three for the Money
The Brave Little Plant	Phillip and Ninety-nine Frogs
The Emperor and the Nightengale	Who Did It?

Skills Covered: General

Vendor Code: 33

Interest Levels: Elementary

Non-Consumable

Instructional Levels: PP-3.2

Approximate Price: Pre-Primer and Primer Levels - \$.48 each
1st Reader - .54 each
2₁, 2₂, 3₁, 3₂, - .60 each

Description: Softbacks to accompany each level of the basic reading program to give pupils enjoyable reading experiences beyond their daily lessons.

SCHOOL SKILL TRACING BOARD

Skills Covered:

Vendor Code: 40

Interest Levels:

Non-Consumable

Instructional Levels: K, 1, 2

Approximate Price: \$27.75

Description: The Tracing Board was designed for children who demonstrated the perceptual readiness for primitive drawing, but had not yet developed the eye-hand skills equal to their visual form-shape discrimination abilities. It is appropriate for children in special classrooms whose cultural and academic development has been delayed. The Tracing Board is useful for any child whose handwriting is so scribbled or forced that writing is a deterrent, rather than a reinforcement to learning. The slanted board is covered with a special fiberglass material so that the children can use special rub-off crayons to trace their patterns. There are 29 patterns or symbols in developmental sequence.

SHAPES AROUND US SERIES

What Is Round?

What Comes In A Can?

What Has Three Sides?

What Comes In A Box?

What Has Four Sides

What Shape Is It?

Skills Covered: Perception

Vendor Code: 9

Interest Levels: Elementary

Non-Consumable

Instructional Levels: P-1

Approximate Price: \$1.80 each

Description: This hardback series was designed for use of pupils in primary (or low intermediate) grades. Basically, children are made aware of shapes and sizes. Stories are arranged in alphabetical order and the same characters are present throughout the series.

SIGHT AND SOUND OF PHONICS

Skills Covered: Word Recognition

Vendor Code: 16

Interest Levels: Elementary, Junior High

Non-Consumable

Instructional Levels: 1-6

Approximate Price: \$84.50

Description: A colorful transparency program from which students can establish a basic foundation in word attack skills. Makes use of the kinesthetic, auditory, and visual approaches. The program is divided into four sound study areas: Consonants, Consonant Blends, Digraph, and Vowels. Complete program, including 40 transparencies with carrying and storage case.

SINGER STRUCTURAL SERIES

Pupil Books
Key-Picture Cards
Sound-Picture Cards

Reading Dominoes
Vocabulary Development Booklets
Teacher's Edition

Skills Covered: General

Vendor Code: 45

Interest Levels: Primary

Non-Consumable

Instructional Levels: K-3

Approximate Price:

Pupil Books:	- \$1.08 - \$1.59
Key-Picture Cards	- 3.36
Sound-Picture Cards	- 4.62
Reading Dominoes	- 2.91
Vocabulary Development Booklets	- 2.01

Description: A series of colorful text-workbooks and materials systematically sequenced to teach basic reading skills. Key-Picture Cards provide aid in initial consonant and short vowel sounds. Sound-Picture Cards are designed to extend oral vocabulary and develop auditory discrimination of initial sounds. The Dominoes are for analyzing words. The Vocabulary Development Booklets provide opportunities for using many skills.

SPELLING WORD POWER LABORATORIES

Laboratory IIa
Laboratory IIb
Laboratory IIc
Laboratory IIIa

Skills Covered: Spelling - Phonics

Vendor Code: 43

Interest Levels: Junior High, Senior High

Non-Consumable

Instructional Levels: 4 - 7

Approximate Price: \$69.95

Description: The Spelling Word Power Laboratory consists of comprehensive sets of learning materials that incorporate modern techniques of multi-level instruction. The multi-level format provides individualized programming for the spelling skills.

STORIES FOR FIRST PHONICS

Skills Covered: Independent

Vendor Code: 18

Interest Levels: Elementary

Non-Consumable

Instructional Levels: 1, 2, 3

Approximate Price: \$1.25

Description: A paperbound book (109 pages) with line drawn illustrations. The text utilized only short vowels and sight words.

SRA READING LABORATORIES

Laboratory IIIa
Laboratory IIIb

Skills Covered: General Vocabulary, Comprehension, Rate

Vendor Code: 43

Interest Levels: Junior High, Senior High

Non-Consumable

Instructional Levels: 3-12

Approximate Price: \$65.00 each

Description: Series of graded skill development materials. Labs IIIa and IIIb include note-taking skills.

STOP WATCH OR TIMER

Interval Test Timer

Bid-Item

Approximate Price: \$11.50

Non-Consumable

STORIES FOR TEEN-AGERS

Book A - Red
Book B - Blue
Book 1 - Yellow
Book 2 - Green

Skills Covered: Comprehension

Vendor Code: 22

Interest Levels: Junior High, Senior High

Non-Consumable

Instructional Levels: 4-5

Approximate Price: \$2.40 each

Description: Anthologies in which selections have been chosen for adolescent appeal. Books A and B include discussion and multiple choice comprehension questions for each selection. Books 1 and 2 include discussion questions for each unit, with a final review quiz which includes punctuation, vocabulary and main idea questions.

STUDY SCOPES READING PROGRAM

Skills Covered: Phonetic Analysis, Structural Analysis

Vendor Code: 46

Interest Levels: Elementary

Non-Consumable

Instructional Levels: K-4

Approximate Price: \$94.50

Description: A complete set of materials including 15 Study Scopes, 6 levels of printed programs (consonants, blends, vowels, word structure, meaning and syllabication), 6 individual study scribes, 30 pupil progress charts, 30 teacher reports and one teacher manual. Complete classroom lab in metal cabinet. It provides opportunities for children to learn on an independent, individualized basis.

SULLIVAN PROGRAMMED READING

Book 1	Book 8	Book 15
Book 2	Book 9	Book 16
Book 3	Book 10	Book 17
Book 4	Book 11	Book 18
Book 5	Book 12	Book 19
Book 6	Book 13	Book 20
Book 7	Book 14	Book 21

Skills Covered: General

Vendor Code: 32

Interest Levels: Elementary

Non-Consumable

Instructional Levels: 1-3

Approximate Price:

Description: Remedial Program for children on all elementary levels. The evaluation set includes one copy of all pupil and teacher materials, except filmstrips, which are included in the whole Programmed Reading Series.

SULLIVAN STORYBOOK CLASSROOM LIBRARY SET

Skills Covered: Independent Reading

Vendor Code: 32

Interest Levels: Elementary

Non-Consumable

Instructional Levels: 1-3

Approximate Price: \$52.50

Description: The library set is correlated with the Programmed Reading Program. Using a linguistic progression, books gradually increase in difficulty, adding new vocabulary.

SYSTEM 80

System 80 Audio-Visual Unit

Vendor Code: 47

Non-Consumable

Approximate Price: About \$495.00

SYSTEM 80 PROGRAM

Learning Letter Names

Kit A

Kit B

Developing Spelling Skills

Kits A, B, C, D, E, F, G

Reading Words in Context

Kits A, B, C, D, E, F, G, H

Skills Covered: Spelling, Vocabulary, Letter Recognition

Vendor Code: 47

Interest Levels: Elementary

Non-Consumable

Instructional Levels: K-6

Approximate Price: \$125.00 each kit

Description: Kit contains 9 audio-visual lessons and teacher's guide. Audio-visual lesson has record, film slide, and student progress check. Audio-visual test, placement and progress test tabs, test tabs, and student record book.

TACHISTOSCOPIC (TACH-X) FILMSTRIPS

Perceptual Readiness - Set 10
Primary Letters - Set 21
Intermediate Numbers - Set 30
Advanced Accuracy - Set 40
Looking at Words:
Set A, Set B
Set C, Set D
Set E, Set F

EDL Sight Vocabulary:
Set A, Set B
Set C, Set D
Set E, Set F
Set V-789
Set V-1011

Skills Covered: Perceptual Development, Vocabulary

Vendor Code: 47

Interest Levels: Elementary, Junior High, Senior High

Non-Consumable

Instructional Levels: K-12

Approximate Price: Sets 10, 21, 30, and 40 - \$62.50

EDL Sight Vocabulary: A-C - \$30.00 each
E-F - 21.00 each
V-789 - 55.00
V-1011 - 37.00
EDL Looking At Words: A-C - 30.00 each
E-F-- 21.00 each

Description: Through timed exposures to pictures, numbers and letters, student learns to pay attention to detail, left-to-right sequence, and remember more of what they see. Workbooks and teacher lesson plans are available for the Looking At Words Set.

TACHISTOSCOPE FILMSTRIPS

Set ABC Basic Accuracy Filmstrips
Look and Write (Eye-Hand Coordination workbook)
Set 22 Primary Supplementary
Set 31 Intermediate Supplementary

Skills Covered: Perception

Vendor Code: 47

Non-Consumable

Approximate Price: Set ABC - \$50.00
Workbooks - 1.50 each
Set 22 - 28.00
Set 31 - 50.00

Description: Tach-X training helps the beginning reader build visual discrimination skills and helps the older student sharpen his power of visual perception and retention. Flash exposures can be released for as long as 1½ seconds or as brief a time as 1/100 of a second. Students say or write what they see. Machine may be used individually but is a very effective group instrument.

Set ABC Basic Accuracy contains..25 filmstrips.

TACHOMATIC 500 PROJECTOR

Interest Levels: Elementary, Junior High, Senior High

Vendor Code: 42

Approximate Price: \$295.00

Non-Consumable

Description: A group training instrument offering a special range from 100 to 1200 wpm.

TACHOMATIC WORDS AND PHRASES FILMSTRIPS

Grade 1
Grade 2

Grade 3
Grade 4

Grade 5
Grade 6

Skills Covered: Visual Perception, Vocabulary

Vendor Code: 42

Interest Levels: Elementary, Junior High, Senior High

Non-Consumable

Instructional Levels: 1-6

Approximate Price: \$43.00

Description: Each set of 20 filmstrips presents the basic vocabulary.

TACH-X TACHISTOSCOPE

Vendor Code: 47

Approximate Price: \$200.00

Description: Teacher's guide and case provided. Machine may be converted to a filmstrip projector.

TANGRAMS

Skills Covered: Perceptual Development

Vendor Code: 32

Interest Levels: K-4

Non-Consumable

Instructional Levels: K-4

Approximate Price: Teacher's Guide - \$1.50
Tangram Cards - 4.20 (1 set needed)
Tangram Pieces - 2.40 (2 sets suggested)

Description: Suggested for grades K-4. The Tangram is a geometrical puzzle consisting of 7 pieces dissected for a square. The student is provided with cards upon which are printed a variety of shapes. The 70-odd cards supply a wide range of difficulty. There are four sets of seven pieces included in each order, meaning that four children can engage in the work at one time.

TAPE RECORDER

Concord #220 Tape Recorder, Monaural

Vendor Code: 8

Approximate Price: \$100.50

TEACHING TYPEWRITER

Teaching Typewriter

Skills Covered: Visual, Motor

Vendor Code: 11

Interest Levels: 1-4

Non-Consumable

Instructional Levels: 1-4

Approximate Price: \$59.00

Description: The teaching typewriter is a sturdily built program teaching machine which offers instruction in reading. The machine is self-pacing.

TEACHING TYPEWRITER PROGRAMS

Animal Friends
Discovering Colors
Exploring Numbers 1-5
Learning to Count
Alphabet Progression
Reading and Spelling (Beginners)
Reading and Spelling (Fun with words) - 2 Sets
Exploring Numbers 1-10
Opposites - 10 Concepts - Multiple Choice

Skills Covered: Voc.-No. Concepts, Letter Recognition, Spelling

Interest Levels: Elementary

Vendor Code: 11

Instructional Levels: K-1

Non-Consumable

Approximate Price: \$1.50 per set

Description: Each program consists of a group of 20 programmed cards. The child responds to the picture, word, color, number, or other visual stimulus by pressing the correct typewriter key.

TEEN-AGE TALES (A,B,C)

Teen-Age Tales, Book A
Teen-Age Tales, Book B
Teen-Age Tales, Book C

Skills Covered: Independent Reader

Vendor Code: 25

Interest Levels: Junior High, Senior High

Non-Consumable

Instructional Levels: 3-4

Approximate Price: \$2.46 per book

Description: These are supplemental independent readers which do not include a particular skill emphasis (reading for pleasure). Teacher manuals are available. Ten per classroom of each level are recommended.

TEEN-AGE TALES (1-6)

Teen-Age Tales, Book 1
Teen-Age Tales, Book 2
Teen-Age Tales, Book 3

Teen-Age Tales, Book 4
Teen-Age Tales, Book 5
Teen-Age Tales, Book 6

Skills Covered: Independent Reader

Vendor Code: 25

Interest Levels: Junior High, Senior High

Non-Consumable

Instructional Levels: 5-6

Approximate Price: \$2.46 per book

Description: These are supplemental independent readers which do not include a particular skills emphasis (reading for pleasure). Teacher manuals are available. Ten per classroom of each level are recommended.

THESAURI

In Other Words I
A Beginning Thesaurus
In Other Words II
A Junior Thesaurus

Skills Covered: Reference

Vendor Code: 43

Interest Levels: 3 - 12

Non-Consumable

Instructional Levels: 3 - 6

Approximate Price: Book I - \$2.55; Book II - \$3.06

Description: In Other Words I is a 240 page thesaurus designed to develop awareness of the precise meaning of words and to extend and enrich speaking and writing vocabularies.

In Other Words II is more adult in format and entry and information than the junior edition. There are more than 300 entry words and about 3,000 synonyms.

THE TIME MACHINE SERIES

Leonard Visits Space
Leonard Visits the Ocean Floor
Leonard Discovers America
Leonard Visits Sitting Bull

Leonard Goes to the Olympics
Leonard Equals Einstein
Leonard Discovers Einstein

Skills Covered: Independent Reading

Vendor Code: 19

Interest Levels: Elementary, K - 3

Non-Consumable

Instructional Levels: P - 2.5

Approximate Price: \$1.50 each

Description: Independent readers with high interest level and low vocabulary. The series is boy oriented. Recordings are available with each book. Teacher Manual is available for \$.75.

THORNDIKE-BARNHART ADVANED JUNIOR DICTIONARY (4th Edition)

Thorndike-Barnhart Advanced Jr. Dictionary (4th Edition)

Skills Covered: Dictionaries - Reference

Vendor Code: 44

Interest Levels: Junior High

Non-Consumable

Instructional Levels: 7-8

Approximate Price: \$3.72 each

Description: A distionary for average and below average 7th and 8th graders. 68,500 entries; 86,000 definitions; 22,700 illustrative and explanatory sentences and phrases, 1,800 pictures, diagrams, maps. Words are easy to locate and definitions are accurate and clear. More than 100 dictionary - using exercises. Manual included.

TIME FOR SOUNDS

Time for Sounds, Kit A

Time for Sounds, Kit B

Skills Covered: Auditory Discrimination

Vendor Code: 14

Interest Levels: K-2

Non-Consumable

Instructional Levels: K-2

Approximate Price: Each Kit - \$4.50

Description: Instructional aid kits, Level 1 and 2 (Kits A and B) which use a picture approach to improve auditory skills. Kit A deals with consonant sounds. Kit B deals with blends and diagraphs. The kits may be used for group or individual work.

T-MATIC FILMSTRIPS

- Span of Perception PTF-3 (20 filmstrips)
- Letter Recognition RDF-1 (20 filmstrips)
- Words and Phrases VCF-1 (20 filmstrips)
- Words and Phrases VCF-2 (20 filmstrips)
- Words and Phrases VCF-3 (20 filmstrips)
- Remedial Reading Filmstrips RPF-1 (20 filmstrips)
- Spelling Word List SDF-2 (30 filmstrips)
- Spelling Word List SDF-3 (30 filmstrips)
- Spelling Word List SDF-4 (30 filmstrips)
- Spelling Principles SDF-41 (30 filmstrips)

Skills Covered: Perception, Letter Recognition, Vocabulary, Spelling

Interest Levels: Elementary, Junior High, Senior High

Vendor Code: 42

Instructional Levels: 1-8

<u>Approximate Price:</u>	PTF-3	\$50.00	(Set of 20)
	RDF-1	60.00	(Set of 20)
	VCF-1	60.00	(Set of 20)
	VCF-2	60.00	(Set of 20)
	VCF-3	60.00	(Set of 20)
	RRF-1	60.00	(Set of 20)
	SDF-2	76.00	(Set of 30)
	SDF-3	76.00	(Set of 30)
	SDF-4	76.00	(Set of 30)
	SDF-41	76.00	(Set of 30)

Description: Strips are for use with T-Matic as tachistoscopic training instrument.

T-MATIC 150 PROJECTOR

T-Matic 150 Projector
TeMatic 150B Projector

Skills Covered: Perception, Visual Discrimination

Vendor Code: 42

Interest Levels: Elementary, Junior High, Senior High

Non-Consumable

Instructional Levels:

Approximate Price: 150 - \$99.50, 150B - \$124.50

Description: The T-Matic 150 gives the range of speed from 1/100 of a second down to 4 seconds.

TOK-BACK

Tok-Back

Skills Covered: Auditory Discrimination, Oral Reading Skills

Vendor Code: 48

Interest Levels: Elementary

Non-Consumable

Insturctional Levels: 1

Approximate Price: \$3.00

Description: Plastic voice reflector. The student wears this device which aids in building auditory discrimination skills and improves skill in oral reading.

TRY EXPERIENCE FOR YOUNG CHILDREN

TRY Experience for Young Children

Skills Covered: Perception

Vendor Code: 37

Interest Levels: Elementary

Consumable

Instructional Levels: K-1

Approximate Price: Kit \$20.00

Description: The manipulative materials of the Regular Kit can be used through the year. However, the Activity books when used properly are consumed and one is required per child.

Each stage of TRY included a set of manipulative materials and an Activity Book. Each page of the Activity Book introduces a Visual-Perceptual Experience on the front side and a Related-Expressive Experience on the reverse side.

Task 1 consists of four geometric shapes of three different sizes. The experiences are discrimination shapes, size, rotations, left to right and top to bottom orientation.

Task 2 consists of twenty identical red and white blocks, each having four different designs and two solid colors. The experiences are matching sides of blocks to designs illustrated on pages of the Activity Book.

Task 3 consists of white plastic tiles with the upper and lower case of the alphabet, tiles imprinted with punctuation and blank tiles. The letters are printed in black and raised slightly. The experiences are matching tiles to letter forms.

Task 1	Activity Book	\$1.00
	Teacher Guide	.92
Task 2	Activity Book	.92
	Teacher Guide	.92
Task 3	Activity Book	1.00
	Teacher Guide	1.00

TURNER-LIVINGSTON COMMUNICATION SERIES

The Television You Watch
The Phone Calls You Make
The Newspaper You Read
The Movies You See
The Letters You Write
The Language You Speak

Skills Covered: Comprehension

Vendor Code: 20

Interest Levels: Junior High, Senior High

Non-Consumable

Approximate Price: \$1.20 each, Teachers Guide - \$2.00

Description: 138 structured lessons in six workbooks that help the student understand the facts, concepts and opportunities in the world of modern communications.

UNIVERSAL WORKBOOKS IN PHONICS (1-5)

Universal Workbooks in Phonics (1)
Universal Workbooks in Phonics (2a)
Universal Workbooks in Phonics (2b)
Universal Workbooks in Phonics (3a)
Universal Workbooks in Phonics (3b)
Universal Workbooks in Phonics (4a)
Universal Workbooks in Phonics (4b)
Universal Workbooks in Phonics (5)

Skills Covered: General

Vendor Code: 34

Interest Levels: Elementary, Junior High

Consumable

Instructional Levels: 1-5

Approximate Price: \$3.25 each level

Description: Spirit duplicating books (approximately 100 clear copies per master). Skills developed in phonics and auditory discrimination, word meanings; word building and in upper levels dictionary skills.

WEBSTER READING CLINIC

Webster Clinic 10X

Conquests in Reading (10 copies and 1 T.E.)
The Magic World of Dr. Spello (10 copies and 1 T.E.)
Teachers Guide for Remedial Reading (1 copy)
Reading Skill Cards (1 set of 224 cards)
New Webster Word Wheels (1 set of 63 wheels)
The Everyreader Series (20 books)
Group Word Teaching Game (1)
Basic Sight Vocabulary Cards (1 set - 220 cards)

Skills Covered: Reading, Spelling, Vocabulary, Phonics

Vendor Code: 32

Interest Levels: Elementary

Non-Consumable

Instructional Levels: 2-6

Approximate Price: \$81.00

Description: A comprehensive kit to correct reading difficulties. A variety of remedial materials are provided which children can work with independently or with the teachers help.

WILDLIFE ADVENTURE SERIES

Reading Level

2.6	Gatie the Alligator
2.8	Sleeky the Otter
3.0	Skipper the Dolphin
3.2	Towry the Mountain Lion
3.5	Bounder the Jackrabbit
3.6	Thor the Moose
3.7	Ruff the Wolf
4.4	Arctos the Grizzly

Skills Covered: Independent Readers

Vendor Code: 19

Interest Levels: Elementary, Junior High

Non-Consumable

Instructional Levels: 2-12

Approximate Price: First 5 titles - \$1.80
Last 3 titles - 1.95
Teachers Manual - .75

Description: An adventure series related to science and natural science. It has a high interest range and low readability.

WE READ MORE STORIES (Small Readers)

The Three Billy Goats Gruff	The House that Jack Built
The Old Woman and Her Pig	All Mine and Kindness
Little Sambo	Nursery Rhymes
Aesop's Fables	The Wishing Book
The Three Bears	The Lambkin
The Little Red Hen	Gentle as a Lamb
The Little Engine That Could	How the Robin Got His Red-Breast
The Gingerbread Boy	Winter
The Boy and the Goats	Summer
The Little Red Hen and the Fox	Spring
	Fall

Skills Covered: Independent Reading

Vendor Code: 33

Interest Levels: Elementary

Non-Consumable

Instructional Levels: 1

Approximate Price: Set \$4.46

Description: A set of paperback readers that are written so that the child can read the entire booklet at one sitting.

The set contains many old favorites that children have already heard - with the controlled vocabulary a child can read the story for himself.

"WHAT JOB FOR ME" SERIES

Charley the TV Repairman	Carman the Beautician
John the Second Best Cook in Town	Cool It, Man!
Pete the Service Station Attendent	Tom the Merchant Seaman
Nick the Waiter	Phil the File Clerk
Joe the Retail Salesman	Tim the Draftsman
Judy the Waitress	Keep it Clean
Frank the Vending Machine Repairman	Sandy the Lineman
Betty and Her Typewriter	Burt the Policeman
Ginny the Office Assistant	Ned the Taxicab Driver

Skills Covered: Independent Reading

Vendor Code: 32

Interest Levels: Junior High, Senior High

Non-Consumable

Instructional Levels: 4

Approximate Price: \$.90

Description: Each book is written in simple action style. The books provide answers to questions about jobs usually held by non-college educated people.

WINTER HAVEN LIONS PROGRAM

Teacher's Basic Perceptual Testing and Training Kit

Skills Covered: Perception

Vendor Code: 50

Interest Levels: K-3

Non-Consumable

Instructional Levels: K-3

Approximate Price: \$14.00

Description: Testing should be administered by the reading teacher but follow-up can be handled in the classroom. Material is designed for testing of perceptual deficiencies and for training in those areas.

WOLLENSAK TEACHING TAPES

Introduction to the Listening Experiences

Sounds at Home

Sounds We See

Walking Sounds

Word Attack Skills:

Approximately 50 tapes on recognition and location of short vowels and consonants

Building Sight Vocabulary

Syllables (6 tapes)

Skills Covered: Listening, Phonics

Vendor Code: 35

Interest Levels: K-6

Non-Consumable

Instructional Levels: K-2

Approximate Price: \$7.95 per pkg (includes tape, student worksheets and Teachers Guide; specify R or C for reel or cassette)

WORDS IN COLOR

Words in Color

Skills Covered: Word Attack

Vendor Code: 51

Interest Levels: Elementary, Junior High, Senior High

Non-Consumable

Instructional Levels: K-12

Approximate Price: Complete Set \$110.00

Description: Complete set includes workbooks for 20 students. This program is included so that a unique approach may be used for the student having severe and persistent difficulties "unlocking" words.

WORLD OF ADVENTURE SERIES

Lost Uranium Mine
Flight to the South Pole
Hunting Grizzly Bears
Fire on the Mountain

City Beneath the Sea
The Search for Piranha
Sacred Well of Sacrifice
Viking Treasure

Skills Covered: Comprehension, Sight Vocabulary Building,
General Reading Skills

Vendor Code: 6

Interest Levels: Junior High

Non-Consumable

Instructional Levels: 2-6

Approximate Price: Each Title \$2.20
Complete Set of 8 Titles \$17.60
Series Activity Workbook 1.80
Teachers Guide 1.20 (free with class order)
25% discount on price - six or more copies

Description: The World of Adventure Books are series for Junior High School Remedial Reading. Six to eight copies needed for class of 20.

GAMES FOR READING LABORATORY

<u>Game</u>	<u>Cost</u>	<u>Vendor Number</u>	<u>Interest Level</u>	<u>Skill Emphasis</u>
Consonant Lotto	\$ 1.98	21	Elem.	Phonics
Dog House Game	1.50	15	Elem.	Phonics
Fun With Words	4.50	14	Elem.	Basic Vocabulary
Jr. Phonic Rummy	1.50	15	Eler.	Phonics
Match, Set 1	1.00	21	Elem.	Basic Vocabulary
Match, Set 2	1.00	21	Elem.	Basic Vocabulary
Phonics We Use - Set A	39.00	30	Elem.	Phonics
Phonics We Use - Set B	39.00	30	Elem./Jr.	Phonics
Phonetic Quizmo	2.00	15	Elem.	Phonics
Read and Say Verb Game	1.50	21	Elem./Jr.	Basic Vocabulary
Riddle-Rhyme Time, Set A	4.50	14	Elem.	Structural Analysis
Riddle-Rhyme Time, Set B	4.50	14	Elem.	Structural Analysis
Sight Phrase Cards	1.00	21	Elem./Jr./Sr.	Basic Vocabulary
Spelling Games Kit	39.00	30	Elem.	General Reading Skills
Take	1.50	21	Elem.	Phonics and Discrimination
Vowel Lotto	1.98	21	Elem.	Phonics
What the Letters Say	1.98	21	Elem.	Phonics

<u>PUBLISHERS</u>	<u>REPRESENTATIVES</u>	<u>VENDOR CODE NO.</u>
Addison-Wesley Publishing Company 16 Executive Park Drive Atlanta, Georgia 30329	James F. Dandridge Leesburg, Florida (904) 787-6801	1
Reading Development Kits		
American Guidance Service Publisher's Building Circle Pines, Minnesota 55014		2
Peabody Language Development Kits		
Appleton-Century-Croft Publishing Co. 440 Park Avenue, South New York, New York 10016		3
Phonics with Write and See		
Audio-Visuals of Tampa P.O. Box 10099 Tampa, Florida		4
Headsets with Junction Box		
Barnell-Loft, Ltd. 111 South Centre Avenue Rockville Centre, New York 11571		5
Barnell-Loft Specific Skill Series		
Benefic Press Publishing Division of Beckley-Gardy 10300 W. Roosevelt Road Westchester, Illinois 60153	Mr. George N. MacMullen 6851 Roswell Road, N.E. D-21 Atlanta, Georgia 30328	6
Mystery Adventure Series World of Adventure Series		
Bowmar Publishing Company 622 Rodier Drive Glendale, California 91201	Dave Driscoll c/o Cook Consultants P. O. Box 22857 Ft. Lauderdale, Florida 33315	7
Multi-media kit, Reading Incentive Program Reading Incentive Program		

PUBLISHERSREPRESENTATIVESVENDOR
CODE
NO.

Brandon's Inc.
P.O. Box 5519
Jacksonville, Florida

8

Tape Recorder

Century Consultants
6363 Broadway
Chicago, Illinois 60626

Harvey M. Heagerty
District Manager
6680 13th Avenue North
St. Petersburg, Florida 33710

9

Holt Basic Language Skills Program
Shapes Around Us Series

Century Schoolbook Press
San Francisco, California

10

Learning to Read While Learning to Learn

Childcraft Equipment Company
155 East 23rd Street
New York, New York 10010

Allan S. Redmon
80 N.E. 132nd Street
North Miami, Florida 33161

11

Teaching Typewriter
Teaching Typewriter Programs

Cook Consultants
P.O. Box 22857
Ft. Lauderdale, Florida 33303

Dave Driscoll
7812 Plantation Drive
Orlando, Florida 32810

12

Hoffman Reader
Hoffman Reader Programs
Language Master
Language Master Programs

Craig Corporation
3410 S. LaCienega Blvd.
Los Angeles, California

13

Craig Reader
Craig Reader Programs

PUBLISHERSREPRESENTATIVESVENDOR
CODE
NO.

Dexter and Westbrook, Ltd.
111 S. Central Avenue
Rockville Centre, New York 11571

Time for Sounds

14

Drago
2920 N.W. 7th Street
Miami, Florida 33125

Bob L. Smith
Vice-President

15

Ideal Listen-Look-Learn Reading Tapes
Instructo-First Experiences with Vowels and Consonants
Games

Educational Electronics
607 Sheridan
Oklahoma City, Oklahoma

Phonics in a Nutshell
Sight and Sound of Phonics

16

Educational Record Sales
157 Chamber Street
New York, New York 10007

Perception Filmstrips

17

Educators Publishing Service
75 Moulton Street
Cambridge, Massachusetts

John Alden Cox
1215 N.E. 150th Street
N. Miami, Florida 33161

18

Phonetic Readers Series
Primary Phonics
Royal Road Miniature Readers
Stories for First Phonics

Field Educational Publishers
609 Mission Street
San Francisco, California 94105

Checkered Flag Learning System
Deep Sea Adventure Series
Jim Forest Readers
Morgan Bay Mystery Series
The Time Machine Series
Wildlife Adventure Series

19

<u>PUBLISHERS</u>	<u>REPRESENTATIVES</u>	<u>VENDOR CODE NO.</u>
Follett Publishing Company 1010 W. Washington Blvd. Chicago, Illinois 60607		20
Frostig Development Program Frostig Program Box Frostig Test Materials Turner-Livingston Communication Series		
Garrard Publishing Company Champaign, Illinois 61820		21
Dolch Readers		
Globe Book Company 175 Fifth Avenue New York, New York		22
Stories for Teen-Agers		
Grolier Educational Corporation 845 Third Avenue New York, New York 10022	E. T. Chamberlin 1502 N. Amanda Circle, N.E. Atlanta, Georgia 30329	23
Reading Attainment I Reading Attainment II Reading Attainment System		
Harvard Supply Company P. O. Box 32 Mebane, Massachusetts 02176		24
Interval Test Timer		
D. C. Heath and Company 1731 Commerce Drive, N.W. Atlanta, Georgia 30318	Bob Osteam P. O. Box 209 Ft. Lauderdale, Florida 33302	25
Miami Linguistic Readers Teen-Age Tales (1-6; A,B,C)		

VENDOR
CODE
NO.PUBLISHERSREPRESENTATIVES

Judy Company
Minneapolis, Minnesota 55401

26

Flannel Board
Flannel Board Letters

Learning Materials, Inc.
100 East Ohio Street
Chicago 11, Illinois

27

The Literature Sampler

Learning Research Association, Inc.
1501 Broadway
New York, New York 10036

28

Michigan Language Program
Michigan Tracking Program

J. B. Lippincott Company
Educational Publishing Division
East Washington Square
Philadelphia, Pennsylvania 19105

29

Reading for Meaning Series

Lyons and Carnahan
2500 Prairie Avenue
Chicago, Illinois 60616

Edward T. Carr
1406 Edmundshire Lane
Orlando, Florida 33803

30

Motivation Readers
Pacesetters in Personal Reading
Phonics We Use Series

McCormick-Waters
300 Pike
Cincinnati, Ohio 45202

Mr. Lynn Campbell
536 W. Oak Drive
Lakeland, Florida 33803

31

Building Reading Skills Series

VENDOR
CODE
NO.

PUBLISHERSREPRESENTATIVES

McGraw-Hill Book Company
80 Forrest Road, N.E.
Atlanta, Georgia 30312

Rossiter J. Drake
The Kensington, Apt. 2C
1900 S. Ocean Blvd.
Pompano Beach, Florida

32

Conquests in Reading
Dr. Spello
Eye and Ear Fun (1-4)
Let's See
New Practice Readers
Reading for Concepts (A-H)
Sullivan Programmed Reading
Sullivan Storybooks - Classroom Library Set
Tangrams
"What Job for Me?" Series
Webster Reading Clinic

Macmillan Company
155 Ottley Drive, N.E.
Atlanta, Georgia 30324

Charles G. Miles
199 S.W. 15th St., Apt 3
Boca Raton, Florida

33

Decoding for Reading
Gateway Series, Level Three Anthologies
Macmillan Reading Spectrum
Readingtime Books
We Read More Stories

Charles E. Merrill Publishing Company
1300 Alum Creek Drive
Columbus, Ohio 43216

34

Merrill Linguistic Readers
Merrill Mainstream
Merrill Refresher Program of Linguistic Readers
New Modern Reading Skilltexts
Universal Workbooks in Phonics (1-5)

Lincom Division
3-H Center
St. Paul, Minnesota

35

Kollensak Teaching Tapes

VENDOR
CODE
NO. _____

PUBLISHERS

REPRESENTATIVES

Modern Curriculum Press
P. O. Box 9
Berea, Ohio 44017

36

Phonics Is Fun

Noble and Noble Publishing Company
750 Third Avenue
New York, New York 10017

37

TRY Experiences for Young Children

Peterson Handwriting
P. O. Box 249
Greenburg, Pennsylvania 15601

38

Improve Your Writing for Job Success Series
and Accompanying Materials

Prentice-Hall, Inc.
680 Forrest Road, N.E.
Atlanta, Georgia 30312

Kenneth L. Patrick
Lake Rena Drive
Longwood, Florida 32750

39

Be A Better Reader Series

Programs to Accelerate School Success
Box 1004
Minneapolis, Minnesota

40

School Skill Tracing Board

Readers Digest Service
Educational Division
Pleasantville, New York, 10570

Kenneth Wallace
District Manager
3218 Darlington Oak Drive
Doraville, Georgia 30340

41

Adult Readers
New Reading Skill Builders
Practice Pads

<u>PUBLISHERS</u>	<u>REPRESENTATIVES</u>	<u>VENDOR CODE NO.</u>
School Equipment Dist., Inc. 319 Monroe Street Montgomery, Alabama 36104	Douglas G. Sutherland 762 E. Michigan Avenue Apt. 205 Orlando, Florida 32806	42
Tachomatic 500 Projector Tachomatic Words and Phrases Filmstrips T-matic Filmstrips T-matic 150 Projector		
Science Research Associates 259 East Erie Street Chicago, Illinois 60611	Dave C. Tripp 8 San Jose Drive Ormond Beach, Florida 32074	43
An American Album Better Reading Books Detect Tactile Detect Visual Program How to Study Kaleidoscope of Skills Learning to Think Series Manpower and Natural Resources Kit Pilot Library IIa Pilot Library IIb Pilot Library IIc Pilot Library IIIb Reading for Understanding Series Spelling Word Power Laboratories SRA Reading Laboratory IIIa SRA Reading Laboratory IIIb		
Scott, Foresman and Company 1955 Montreal Road Tucker, Georgia 30084	J. M. Smith 116 E. Woodland Drive Sanford, Florida 32771	44
On Target (Reading for Pleasure Series) Reading for Pleasure Series Thesauri Thorndike-Barnhart Advanced Junior Dictionary		
The L. W. Singer Company 201 East 50th Street New York, New York 10022	Joseph R. Malone P. O. Drawer 1419 Ft. Lauderdale, Florida 33302	45
Singer Structural Series		

PUBLISHERSREPRESENTATIVESVENDOR
CODE
NO.

Study-Scope Company
319 E. Front
Tyler, Texas 75701

46

Study-Scopes

Systems for Learning, Inc.
51 Washington Street
Orlando, Florida 32801

Jerry Bass
51 Washington Street
Orlando, Florida 32801

47

Comprehension Power Series
Controlled Reader (Large)
Controlled Reader (Jr.)
Controlled Reader Filmstrips
EDL Word Clues
Flash-X (Hand Tachistoscope)
Flash-X Programs
Listen and Think Series
System 80
System 80 Programs
Tachistoscope
Tachistoscope Filmstrips
Tachistoscopic Filmstrips

Tok Back, Inc.
P. O. Box 5045
Berkeley, California

48

Tok Back

Teacher's College Press
Teacher's College
525 W. 120th Street
New York, New York 10027

49

Gates-Pearson Reading Exercises
McCall-Crabb Series

Winter Haven Lions Research Foundation, Inc.
P. O. Box 111
Winter Haven, Florida

50

Winter Haven Lions Program

PUBLISHERS

REPRESENTATIVE

VENDOR
CODE
NO.

Xerox Education Division
Learning Materials, Inc.
352 Park Avenue, South
New York, New York 10010

51

Words in Color

BID ITEMS

Filmstrip Projector
Overhead Projector
Portascribe

259

212

INDEX

NOTE: D preceding the numeral indicates the page on which the description of the item is located.

S preceding the numeral indicates the location of the item in the skill listing(s).

-A-

ADULT READERS, D-119; S-77
Aesop's Fables, D-198; S-91
Adventures of Polly Peters, D-176
S-82
Against the Odds, D-154, S-73, 87
Al, D-164; S-89
Ali Baba and the Forty Thieves,
D-164; S-89
All Mine and Kindness, D-198; S-91
Aladdin and the Wonderful Lamp,
D-164; S-89
Alphabet Progression, D-188; S-112,
S-105
Almost Ghost, D-158; S-88
American Album, An, D-134; S-72
Animal Friends, D-188; S-112
Arctos the Grizzly, D-197; S-112
Atomic Submarine Book, D-126; S-77
Audio-Visual Kit A (CHECKERED FLAG),
D-127; S-86
Audio-Visual Kit B (CHECKERED FLAG),
D-127; S-86
AUDITORY DISCRIMINATION, S-69

-B-

Barking Cat, The, D-158
Barnell-Loft Specific Skill Series,
D-120
Drawing Conclusions, D-123; S-69
Following Directions, D-122; S-69
Getting the Facts, D-120; S-69
Getting the Main Idea, D-123; S-70
Locating the Answer, D-122; S-70
Using the Context, D-121; S-70
Working with Sounds, D-121; S-98
Basic Accuracy, Set ABC, D-185; S-96
Basic Language Skills (Mott)
Books 1301-1306, D-156; S-105
Books 1307-1310, D-157; S-74, 109
Basic Sight Vocabulary Cards, D-197;
S-84, 101, 113

BE A BETTER READER SERIES, D-124;
S-107
Be a Better Reader I-VI, D-124;
S-107
Be a Better Reader A,B,C, D-124;
S-108
Bearcat, D-127; S-86
Behind the Scenes, D-148, S-79
Ben Bug, D-164; S-89
BETTER READING BOOKS (1-3), D-125;
S-70, 102
Better Than Gold, D-158; S-88
Betty and Her Typewriter, D-198;
S-92
Biff and Tiff, D-154; S-80
Big, Bigger, Biggest, D-134; S-87
Big Break, The, D-148; S-79
B is for Bicycle, D-154, S-80
Blank Cards (Language Master),
D-148; S-99
Blends and Diagraphs, D-144; S-99, 106
Blue Dog, D-158; S-88
Bounder the Jackrabbit, D-197; S-92
BOWMAR READING INCENTIVE PROGRAM,
D-125; S-85
Multi-Media Kit, D-126; S-85
Boy and the Goats, The, D-198; S-91
Brave Little Plant, D-176; S-82
Building Basic English A,B, D-148;
S-99
BUILDING READING SKILL SERIES, D-126;
S-77
Building Sight Vocabulary (Tapes)
D-199; S-95, 101
Bulldog and the Kitten, D-175; S-90
Burt the Policeman, D-198, S-92

-C-

Camping Trip, The, D-154; S-80
Carman the Beautician, D-198; S-92
Cat and the Bed, D-175; S-90
Chang's Shell, D-154; S-80

INDEX

Charley the TV Repairman, D-198; S-92
CHECKERED FLAG LEARNING SYSTEM, D-127
 Classroom Reading Kit A, D-127; S-86
 Classroom Reading Kit B, D-127; S-86
Chilling Escape, D-148; S-79
City Beneath the Sea, D-200; S-76
Classification - Opposites - Sequence
 (Tapes) D-144; S-72,103
COMPREHENSION, S-69
COMPREHENSION POWER SERIES, D-129;
 S-70,71 (See Controlled Reader
 Filmstrips)
Concord #220 Tape Recorder, D-187
Consonant Lotto, D-201
CONTROLLED READER, JR., D-128
CONTROLLED READER (Large), D-130
CONTROLLED READER FILMSTRIPS, D-128,
 130; S-70,71,102,107
Conquests in Reading, D-129,197; S-104
Cool It, Man!, D-198; S-92
Courage Under Fire, D-154; S-73,87
CRAIG READER, D-131
CRAIG READER PROGRAMS, D-131; S-71,
 92,95,108
Custom Cars, D-125; S-85

-D-

Danger Below, D-132; S-72,86
Deadline for Time, D-148; S-79
DECODING FOR READING, D-132; S-77
DEEP SEA ADVENTURE SERIES, D-132;
 S-72,86
DETECT TACTILE, D-133; S-96
DETECT VISUAL PROGRAM, D-133; S-107
Developing Body Space Perceptual
 Motor Skills, D-162; S-96
Developing Cognitive Skills for
 Young Learners, D-162; S-96
Developing Spelling Skills
 Kits A - G, D-183; S-93,104,111
Dick's Cat, D-154; S-80
Dictionaries (See Reference)
DIMENSIONS IN READING
 An American Album, D-134; S-72
 Manpower and Natural Resources,
 D-152; S-79
Discovering Colors, D-188; S-112
Dog House Game, D-201
Dognappers, D-148; S-79
Dog Pals, D-134; S-87

DOLCH READERS, D-134; S-87
Drag Racing, D-125; S-85
Drag Racing - Funny Cars, D-125;S-85
Drawing Conclusions A-E, D-123; S-69
Dr. SPELLLO, D-135; S-77
Dune Buggies, D-125; S-85
Dune Buggy Racing, D-125; S-85

-E-

Ed, D-164; S-89
EDL Sight Vocabulary
 Set A-F, D-184; S-112
 Set V-789, D-184; S-112
Set V-1011, D-184; S-112
EDL Word Clues
 Book G-L, D-135; S-109
Emperor and the Nightingale, D-176;
 S-82
EQUIPMENT
 Portascribe, D-170
 Concord #220 Tape Recorder
 Monaural, D-187
 Controlled Reader, Jr. D-128
 Controlled Reader, (Large) D-130
 Craig Reader, D-131
 Filmstrip Projector, D-136
 Flannel Board Letters, D-137
 Flannel Board, D-137
 Flash-X (Hand Tachistoscope),
 D-138
 Headsets, D-142
 Hoffman Reader, D-143
 Headset, D-143
 Jackboxes, D-143
 Interval Test Timer, D-180
 Language Master, D-147
 Overhead Projector, D-161
 Portascribe, D-170
 School Skill Tracing Board, D-178
 Timer, D-180
 Tachistoscope, D-184
 T-Matic 150 Projector, D-193
 Tachomatic 500 Projector, D-185
 Tape Recorder, D-187
 Teaching Typewriter, D-188
Everyreader Series, The, D-197;
 S-84,101,113
Exploring Numbers 1-5, D-188; S-94
Exploring Numbers 1-10, D-188;S-94
Eye and Ear Fun,Books 1-4, D-130;S-69

INDEX

-P-

Fall, D-198
 Filmstrips
 Bowmar Reading Incentive Program
 Multi-Media Kit, D-126; S-85
 Checkered Flag Learning System
 Audio-Visual Kit A, D-127; S-86
 Audio-Visual Kit B, D-127; S-86
 Comprehension Power Series, D-128;
 S-70,71
 Controlled Reader Filmstrips
 CR-AA - CR-FA, D-128; S-71,102
 CR-AD, Accelerated Discrimination
 D-130
 CR-MT, Motility Training, D-130
 CR-A - CR-JI, D-130; S-71,102,107
 Perception Filmstrips, D-162; S-96
 Phonics in a Nutshell, D-165; S-99
 Tachistoscope Filmstrips, D-184,185
 Tachomatic Filmstrips, D-186
 T-Matic Filmstrips, D-192
 Filmstrip Projector, D-136
 Fire on the Mountain, D-200; S-76
 First at the Finish, D-119; S-77
 FIRST EXPERIENCE WITH VOWELS AND
 CONSONANTS, D-136; S-99
 Fish who Weren't, D-166; S-89,110
 FLANNEL BOARD LETTERS, D-137
 FLANNEL BOARDS, D-137
 FLASH-X HAND TACHISTOSCOPE, D-138
 FLASH-X PROGRAMS
 Set X-1 - X-6, D-138; S-93,104
 Set X-10, X-12, X-13, X-14, D-138;
 S-93,104
 Flea, D-127; S-86
 Flight to the South Pole, D-200; S-76
 Flying Squirrels, The, D-158; S-88
 Following Directions (A-F), D-122;S-69
 Frank the Vending Machine Repairman,
 D-198; S-92
 Friend for Jenny, A, D-176; S-82
 Friendly Birds, D-134; S-87
 Frogmen in Action, D-132; S-72,86
 FROSTIG DEVELOPMENT PROGRAM, D-139;
 S-96
 FROSTIG PROGRAM BOX, D-139
 FROSTIG TEST MATERIALS, D-140; S-96
 Fun with Words, D-201

-G-

Games, D-201
 Dog House Game, D-201
 Consonant Lotto, D-201
 Fun With Words, D-201
 Jr. Phonic Rummy, D-201
 Match, Set 1, D-201
 Match, Set 2, D-201
 Phonics We Use (Set A), D-201
 Phonics We Use (Set B), D-201
 Phonetic Quizmo, D-201
 Read and Say Verb Game, D-201
 Riddle-Rhyme Time (Set A), D-201
 Riddle-Rhyme Time (Set B), D-201
 Sight Phrase Cards, D-201
 Spelling Games Kit, D-201
 Take, D-201
 Vowel Lotto, D-201
 What the Letters Say, D-201
 GATES PEARDON READING EXERCISES
 Introductory, Level A, D-141; S-77
 Introductory, Level B, D-141; S-77
 Preparatory, Level A, D-141; S-77
 Preparatory, Level B, D-141; S-77
 Elementary, SA, D-141; S-78
 Elementary, RD, D-141; S-78
 Elementary, FD, D-141; S-78
 Intermediate, SA,FD,RD, D-141;S-78
 Advanced SA,FD,RD, D-141; S-78
 GATEWAY SERIES, LEVEL THREE ANTHOLO-
 GIES, D-141; S-78
 Gatie the Alligator, D-197; S-92
 GENERAL READING SKILLS, S-77
 Gentle as a Lamb, D-198; S-91
 Getman Board (See School Skill
 Tracing Board)
 Getting the Facts (A-F), D-126;S-69
 Getting the Main Idea (A-E), D-123;
 S-70
 Gingerbread Boy, The, D-198; S-91
 Ginny the Office Assistant, D-198;
 S-92
 Good-by Tree, D-176; S-82
 Grand Prix, D-127; S-86
 Group Word Teaching Game, D-197;
 S-84,101,113
 Guides to Adventure, D-119; S-77

INDEX

-H-

HANDWRITING (Peterson), D-163; S-85
Happy the Hippo, D-148; S-79
HEADSETS, D-142
HOFFMAN READER, D-143
 Jackboxes, D-143
HOFFMAN READER PROGRAMS
 Achievement Units, D-142; S-72,105
 Horses, D-125; S-85
 Hot Corn Muffins! D-154; S-80
 House That Jack Built, D-198, S-91
 How the Robin Got His Red Breast,
 D-198; S-91
HOW TO STUDY, D-143; S-106
 Teacher's Manual, D-143
 Study Habits Check List, D-143; S-106
 Administrator's Manual for Checklist
 D-143; S-106
Hundred Milers, D-148; S-79
Hunting Grizzly Bears, D-200; S-76

-I-

"I Fell 18,000 Feet", D-119; S-77
I Like Cats, D-134; S-87
I Like Cowboys, D-176; S-82
IDEAL LISTEN-LOOK-LEARN READING TAPES
 D-144; S-72,99,103,106
INDEPENDENT READERS, S-85
In New Directions, D-154; S-73,87
In Orbit, D-161; S-89
In Other Words I, D-190; S-103
In Other Words II, D-190; S-103
Intermediate Supplementary - Set 31,
 D-185; S-96
In the Woods, D-134; S-87
Initial and Final Consonant Tapes,
 D-144; S-99,106
Interval Test Timer, D-180
Introduction to the Listening Experience,
 D-199; S-95,101

-J-

Jack and the Beanstalk, D-164; S-89
Jack the Giant Killer, D-164; S-89
Jet Plant Book, D-126; S-77
Jill's Best Frock, D-175; S-90

JIM FOREST READERS, D-145; S-90
 Jim Forest and Lightning, D-145;
 S-87
 Jim Forest and Ranger Don, D-145;
 S-87
 Jim Forest and the Bandits,
 D-145; S-87
 Jim Forest and the Ghost Town,
 D-145; S-87
 Jim Forest and the Trapper, D-145;
 S-87
Joe the Retail Salesman, D-198; S-92
John the Second Best Cook in Town,
 D-198; S-92
Jr. Phonics Rummy, D-201
Judy the Waitress, D-198; S-92
Julius Caesar, D-148; S-79

-K-

KALEDIOSCOPE OF SKILLS, D-146; S-78
 Book 5-1 - 7-4, D-146; S-78
Karting, D-125; S-85
Keep It Clean, D-198; S-92
Key Picture Cards, D-177; S-83
Kit Kit and the Catfish, D-154; S-80
Kitten and the Stamps, D-175; S-90

-L-

Lamb:in, The, D-198; S-91
LANGUAGE DEVELOPMENT, D-93
LANGUAGE MASTER, D-147
LANGUAGE MASTER PROGRAMS, D-147
Language you speak, D-195; S76
Learning Letter Names,
 Kit A, D-183; S-93,104,111
 Kit B, D-183; S-93,104,111
Learning to Count, D-188; S-94
LEARNING TO READ WHILE LEARNING TO
 LEARN, D-148; S-103
LEARNING TO THINK SERIES, D-149;
 S-94
Leonard Discovers America, D-190;
 S-91
Leonard Discovers Einstein, D-190;
 S-91
Leonard Equals Einstein, D-190;
 S-91

INDEX

Leonard Goes to the Olympics, D-190;
S-91
Leonard Visits Sitting Bull, D-190;
S-91
Leonard Visits Space, D-190; S-91
Leonard Visits the Ocean Floor, D-190;
S-91
LETTER AND NUMBER RECOGNITION, S-93
Letter Recognition, D-192; S-94,97,105
Letters you Write, D-195; S-76
LET'S SEE, D-150; S-69
Linguistic Reader 1-6 (MERRILL), D-153;
S-73
Listen and Think A-R - I, D-149;S-94
LISTENING SKILLS, S-94
LITERATURE SAMPLER, D-151; S-91
Little Engine That Could, D-198; S-91
Little Red Hen, D-198; S-91
Little Red Hen and the Fox, D-198;S-91
Little Sambo, D-198; S-91
Locating the Answer (A-F), D-122;S-70
Lonnie and the Flicker Family, D-176;
S-82
Look and Write, D-185; S-96
Look at Words
Set A-F, D-184; S-112
Lost Uranium Mine, D-200, S-76
Loud and Clear, D-148; S-79

-Mc-

McCall-Crabbe Series, Book A-E, D-153

-M-

Mac and Tab, D-164; S-89
MACMILLAN READING SPECTRUM, D-152;S-73
Magic Bean, the, D-154; S-180
Magic World of Dr. Spello, D-197;S-104
Man on the Penny, D-154; S-80
MANPOWER AND NATURAL RESOURCES KIT,
D-152; S-79
Match, Set 1, D-201
Match, Set 2, D-201
Mark's Jet, D-154; S-80
Matt and the Black Cat, D-154; S-80
Men Who Dare the Sea, D-119; S-77
MERRILL LINGUISTIC READERS, D-153;S-73
MERRILL MAINSTREAM, D-154; S-74,87

MERRILL REFRESHER PROGRAM OF
LINGUISTIC READERS
Book A-D, D-150; S-100
Miami Linguistic Readers, D-154
MICHIGAN LANGUAGE PROGRAM, D-155;
S-69,107
MICHIGAN TRACKING PROGRAM, D-155;
S-107
Mighty Widgets, D-125; S-85
Monkey Friends, D-134; S-87
Moon City, D-166; S-89,110
MORGAN BAY MYSTERY SERIES, D-156;
S-73,88
MOTIVATION READERS, D-158; S-88
Motorcycles, D-125; S-85
MOTT BASIC LANGUAGE SKILLS PROGRAM,
Book 1301-1306, D-156; S-105
Book 1307-1310, D-157; S-74,109
Word Bank, D-157; S-7
Mr. Skinny Arms, D-176; S-82
Movies you See, D-195; S-76
MYSTERY ADVENTURE SERIES, D-158
Mystery Adventure Reader I,
D-158; S-88
Mystery Adventure Reader II,
D-158; S-88
Mystery Adventure at Longcliff
Inn, D-154; S-88
Mystery Adventure of Cave Four,
D-158; S-88
Mystery Adventure of the Indian
Burial Grounds, D-158; S-88
Mystery Adventure of the Jeweled
Ball, D-158; S-88
Mystery Adventure of the Smuggled
Treasure, D-158; S-88
Mystery Adventure of the Talking
Statues, D-158; S-88
Mystery of Marauder's Gold, D-156;
S-88
Mystery of Morgan Castle, D-156;
S-88
Mystery of the Marble Angel,
D-156; S-88
Mystery of the Midnight Visitor,
D-156; S-88
Mystery of the Missing Marlin,
D-156; S-88
Mystery of the Mond's Island,
D-156; S-88
Mystery of the Mountains, D-119;
S-88
Mystery of the Musical Ghost,
D-156; S-88

INDEX

Mystery of the Myrmidon's Journey,
D-156; S-88

-N-

Nat the Rat, D-154; S-80
Ned the Taxicab Driver, D-198; S-92
New Boy, the, D-176; S-76
New Modern Reading Skill Texts,
Books 1,2,3, D-159; S-74,80
NEW PRACTICE READERS
Book A-G, D-159; S-74,109
NEW READING SKILL BUILDERS
Level 1-6, D-160; S-81
Level 7-8, D-160; S-81
Newspaper you Read, D-195; S-76
New Webster Word Wheels, D-197; S-84,
101,113
Nick the Waiter, D-198; S-92
NUMBER RECOGNITION (See Letter and
Number Recognition)
Nursery Rhymes, D-198; S-91

-O-

Old Woman and Her Pig, D-198; S-91
Olly's Alligator, D-176; S-82
On Sunfish Island, D-154; S-80
ON TARGET, D-161; S-89
On the Farm, D-134; S-87
On the Rock in the Pond, D-154; S-80
Once There Was a Bear, D-134; S-87
Once There Was A Cat, D-154; S-87
Once There Was A Dog, D-154; S-87
Once There Was An Elephant, D-154; S-87
Once There Was A Monkey, D-154; S-87
Once There Was A Rabbit, D-154; S-87
Operation Phoenix, D-148; S-87
Opposites, D-188; S-112
OVERHEAD PROJECTOR, D-161

-P-

PACESETTERS IN PERSONAL READING,
D-166; S-89,110
Parade, The, D-176; S-82

PEABODY LANGUAGE DEVELOPMENT KIT
D-166; S-93

Kit P, D-166; S-93
Kit 1,2,3, D-166; S-93
Pearl Divers, The, D-132; S-72,86
Peculiar Lawn Mower, D-148; S-79
Pedro's Secret, D-148; S-79
People in Poetry, D-141; S-78
People Like You, D-154; S-73,87
Perception Filmstrips
Developing Cognitive Skills For
Young Learners, D-162; S-96
Visual Perception Skills,
D-162; S-96
PERCEPTUAL DEVELOPMENT, S-95
Pete the Service Station Attendant,
D-198; S-92
PETERSON HANDWRITING, D-163; S-85
Phil the File Clerk, D-198; S-92
Phillip and Ninety-nine Frogs,
D-176; S-82
Phone Calls you Make, D-195; S-76
Phonetic Quizmo, D-201
PHONETIC READERS SERIES, D-164; S-89
PHONETIC READING SERIES, D-164; S-89
PHONICS, S-98
PHONICS IN A NUTSHELL, D-165; S-99
Book 1,2,3, D-165; S-99
PHONICS WE USE SERIES, D-167; S-100
Book A-G, D-167; S-99
Phonics we Use - Set A, D-167; S-100
Phonics we Use - Set B, D-167; S-100
PHONICS WITH WRITE AND SEE, D-167;
S-100
Phonics With Write and See, A
D-167; S-100
Phonics With Write and See, B
D-167; S-100
Picnic, The, D-175; S-98
Picnic Ship, The, D-154; S-80
PILOT LIBRARY IIa, D-168; S-75,110
PILOT LIBRARY IIb, D-168; S-75,110
PILOT LIBRARY IIc, D-168; S-75,110
PILOT LIBRARY IIIb, D-168; S-75,110
Pip the Pet Rabbit, D-175; S-90
PORTASCRIBE, D-170; S-90
PRACTICE PADS (1,2,3) D-170; S-80
Advanced Pads, D-170; S-80
PRIMARY PHONICS, D-171; S-100
Primary Supplementary - Set 22
D-185; S-96
Princess of the Glass Hill, D-172;
S-82

THE READING LABORATORY
A Selected Bibliography

Chapter Six is designed to aid in the development of a professional reading library within each school. The suggested selections are intended as "core materials" only and should not be construed as inclusive of all desired professional reading materials. These materials should provide a sound basis for professional growth in the teaching of reading and in the diagnosis and remediation of reading problems.

Professional Materials for the School Library

Professional literature for the school library is designed for all teachers involved with the pupil and reading instruction. Literature is listed separately for the elementary and secondary personnel. Broad subcategories have been designated to facilitate the selection of literature. The selection and balance of literature for the school library should be dependent upon the needs of the individual school.

ELEMENTARY

General and Reference:

Chall, Jeanne. Learning to Read: The Great Debate.
McGraw-Hill: New York.

Durr, William K. Reading Instruction: Dimensions and Issues. Houghton Mifflin Company: Boston, 1967.

Selected Bibliography

McKee, Paul. Reading: A Program of Instruction in the Elementary School. Houghton Mifflin Company: Boston, 1966.

Spache, George. Reading in the Elementary School. Allyn and Bacon: Boston, 1968.

Strang, Ruth (et.al.). The Improvement of Reading. McGraw-Hill Book Company: New York, 1967.

Principles of Teaching Reading:

Barbe, Walter B. Educator's Guide to Personalized Reading Instruction. Prentice-Hall, Inc.: Englewood Cliffs, New Jersey, 1961.

Bond, Guy L. and Wagner, Eva Bond. Teaching the Child to Read. MacMillan: New York, 1966.

Hotel, Morton. How to Teach Reading. Follett Educational Corporation: Chicago, Illinois, 1968.

Dechant, Emerald V. Improving the Teaching of Reading. Prentice-Hall, Inc.: Englewood Cliffs, New Jersey, 1968.

Gans, Roma. Common Sense in Teaching Reading. Bobbs-Merrill Company: New York, 1963.

Gray, William S. On Their Own In Reading. Scott, Foresman and Company: Glenview, Illinois, 1960.

Heilman, Arthur W. Principles and Practices of Teaching Reading. Charles E. Merrill Company: Columbus, Ohio, 1967.

Strang, Ruth. Diagnostic Teaching of Reading. McGraw-Hill Book Company: New York, 1964.

Selected Bibliography

Remedial Reading:

- Edington, Ruth. Helping Children With Reading Disability. Developmental Learning Materials: Chicago, Illinois, 1968.
- Fernald, Grace. Remedial Techniques in Basic School Subjects. McGraw-Hill Book Company: New York, 1953.
- Strang, Ruth. Diagnostic Teaching of Reading. McGraw-Hill Book Company: New York, 1964.
- Wilson, Robert M. Diagnostic and Remedial Reading. Merrill Publishing Company: Columbus, Ohio, 1967.

Perceptual Development:

- Chaney, Clara and Kephart, Newell. Motoric Aids to Perceptual Training. Charles E. Merrill Publishing Company: Columbus, Ohio, 1968.
- Kephart, Newell. The Brain-Injured Child in the Classroom. National Society for Crippled Children: Chicago, Illinois, 1963.
- Lewis, Richard. The Perceptually Handicapped. National Society for Crippled Children: Chicago, Illinois, 1963.

Phonics:

- Durkin, Delores. Phonics and the Teaching of Reading. Teacher's College Press: Columbia University, New York, 1968.
- Herr, Selma E. Phonics. Instructional Materials and Equipment Distributors: Los Angeles, California, 1964.

Selected Bibliography

Reading and Listening Aids:

Russell, David and Karp, Etta. Reading Aids Through the Grades: Three Hundred Developmental Reading Activities. Teacher's College Press: Columbia University, New York, 1967.

Russell, David and Russell, Elizabeth. Listening Aids Through the Grades: One Hundred-Ninety Listening Activities. Teacher's College Press: Columbia University, New York, 1967.

SECONDARY

General Information and Reference:

Bamman, Henry A. (et al.). Reading Instruction in the Secondary Schools. David McKay Company, Inc.: New York, 1961.

Bond, Guy L. and Wagner, Eva Bond. Teaching the Child to Read. MacMillan: New York, 1966.

Karlin, Robert. Teaching Reading in High School, Selected Articles. Bobbs-Merrill Company, Inc.: New York, 1969.

Marksheffle, Ned D. Better Reading in the Secondary School. The Ronald Press Company: New York, 1966.

Principles of Teaching Reading:

Botel, Morton. How to Teach Reading. Follett Educational Corporation: Chicago, Illinois, 1968.

Dechant, Emerald and Smith, Henry P. Psychology in Teaching Reading. Prentice-Hall, Inc.: Englewood Cliffs, New Jersey, 1964.

Gans, Roma. Common Sense in Teaching Reading. Bobbs-Merrill Company: New York, 1963.

Selected Bibliography

Heilman, Arthur W. Principles and Practices of Teaching Reading. Columbus, Ohio: Charles E. Merrill Company, 1967.

Strang, Ruth. Diagnostic Teaching of Reading. McGraw-Hill Book Company: New York, 1964.

Remedial Reading:

Edington, Ruth. Helping Children With Reading Disability. Developmental Learning Materials: Chicago, Illinois, 1968.

Fernald, Grace. Remedial Techniques in Basic School Subjects. McGraw-Hill Book Company: New York, 1963.

Strang, Ruth. Diagnostic Teaching of Reading. McGraw-Hill Book Company: New York, 1964.

Wilson, Robert M. Diagnostic and Remedial Reading. Merrill Publishing Company: Columbus, Ohio, 1967.

Reading in the Content Areas:

Fernald, Grace. Remedial Techniques in Basic School Subjects. McGraw-Hill Book Company: New York, 1963.

Viox, Ruth G. Evaluating Reading and Study Skills in the Secondary Classroom. A Guide for Content Area Teachers. International Reading Association: Newark, Delaware, 1968.

Professional Literature for the Reading Laboratory
(Elementary and Secondary)

The following list of recognized professional literature is recommended for purchase for the use of the reading laboratory teacher in the reading laboratory.

Bond, Guy L. and Tinker, Miles A. Reading Difficulties: Their Diagnosis and Correction. Appleton-Century-Crofts, second edition: New York, 1967.

Byrne, Robert. Remedial Reading. Education, Inc.: Washington, D.C., 1968.

Dechant, Emerald. Diagnosis and Remediation of Reading Disability. Parker Publishing Company, Inc.: West Nyack, New York, 1968.

Koetmeyer, William. Teacher's Guide for Remedial Reading. Webster Division, McGraw-Hill Book Company: New York, 1959.

Roswell, Florence and Natchez, Gladys. Reading Disability: Diagnosis and Treatment. Basic Books, Inc.: New York, 1964.