

DOCUMENT RESUME

ED 047 964

SE 010 804

AUTHOR Rigby, Kevin M.  
TITLE A Kit for Teaching Natural Science in Primary Schools.  
INSTITUTION Macquarie Univ., North Ryde (Australia).  
PUB DATE May 70  
NOTE 44p.  
EDRS PRICE EDRS Price MF-\$0.65 HC-\$3.29  
DESCRIPTORS \*Elementary School Science, General Science, Instructional Materials, \*Science Equipment, \*Science Facilities, \*Science Materials  
IDENTIFIERS \*Australia

ABSTRACT

Equipment needed for teaching the New South Wales (Australia) Natural Science course in grades 3-6 is listed. A general list needed for all grades is supplemented by lists of materials needed specifically for each grade. Whenever possible materials available from students' homes are listed, and many examples of improvised equipment are given. Short notes on the use of most materials are provided, although this is not intended to be a comprehensive teacher's guide. (AL)

MACQUARIE UNIVERSITY  
Centre for Advancement of Teaching



AND GLADLY TECHÉ

ED047964

1-990

# A KIT FOR TEACHING NATURAL SCIENCE IN PRIMARY SCHOOLS

U.S. DEPARTMENT OF HEALTH, EDUCATION  
& WELFARE

OFFICE OF EDUCATION  
THIS DOCUMENT HAS BEEN REPRODUCED  
EXACTLY AS RECEIVED FROM THE PERSON OR  
ORGANIZATION ORIGINATING IT. POINTS OF  
VIEW OR OPINIONS STATED DO NOT NECESSARILY  
REPRESENT OFFICIAL OFFICE OF EDUCATION  
POSITION OR POLICY.

by K. M. Rigby



2

A KIT FOR TEACHING NATURAL SCIENCE  
IN PRIMARY SCHOOLS

by

Kevin M. Rigby, B.A., B.Sc., Dip.Ed.  
Lecturer in Science, Wollongong Teachers College

\* \* \*

Photographs by courtesy of N.S.W.  
Department of Education and Family  
Meadow Demonstration School

This booklet was prepared  
as part of a developmental  
project of the Centre for  
Advancement of Teaching  
Macquarie University

## PREFACE

Successful teaching of science in high school depends, to a large extent, on attitudes and interests developed in the primary school. Science lessons in primary grades, however, have been handicapped, at least in some instances, by lack of suitable resources.

This booklet, developed for the Centre for Advancement of Teaching by Mr. Kevin Rigby of Wollongong Teachers College, lists readily available items of equipment for teaching science in Grades Three to Six. While the kit has been developed specifically for primary schools in New South Wales, teachers in other states may well find the recommendations useful as a basis for compiling similar lists.

None of the equipment listed is expensive and it is hoped that schools will consider building stocks of apparatus recommended. In this way primary schools should overcome the problem of providing technical resources for science lessons.

G.R. Meyer,  
Director,  
Macquarie University  
Centre for Advancement of  
Teaching

May 1970

## CONTENTS

	Page
Introduction	1
I. The General Kit	4
II. Special Kit for Third Grade	10
III. Special Kit for Fourth Grade	13
IV. Special Kit for Fifth Grade	20
V. Special Kit for Sixth Grade	30

A KIT FOR TEACHING NATURAL SCIENCE IN N.S.W. PRIMARY SCHOOLS

by

Kevin M. Rigby

Introduction

This booklet contains a list of items recommended for the effective teaching of Natural Science in N.S.W. Primary Schools. The items are accompanied by a brief statement of their uses, together with sources from which they may be obtained. In cases where apparatus cannot readily be purchased, instructions are given for the construction of makeshift models. Emphasis is placed throughout upon the use of readily available materials, most of which can be found around the school or home. In fact, many appropriate experiments can be carried out using objects that are likely to be always at hand; they are not included in this list because there is no point in having them permanently stored as a part of the kit. It is important that children's first contacts with the formal learning of Science should be made via familiar objects: they should come to feel that Science is a study of the world in which we live, rather than an esoteric matter involving scientific apparatus and laboratories.

It is suggested that children should first be presented with a summary of the lists below to take home. Parents may be asked to donate to the school those items on the list that they can spare from around the home, or if they can find nothing appropriate, perhaps they may like to make a small cash donation towards a special Science Equipment Fund. It is surprising what a saving this will make on the expenditure of general school funds. In one school I know of, where this request was made, the response in materials was amazing, and enough cash was received to buy almost all the rest of the kit in one great, spectacular effort.

Printed and pictorial aids are not included in this listing, as a wide range of excellent material is readily available.

Every classroom should have a Science Table and adjacent Science Display Board as a focal area around which all Natural Science activities are concentrated. Close to this should be a chest of drawers, cupboard, or press, which can be locked when not in use. Here can be stored a class kit, consisting of all the material required by a particular class over the whole year.

Items of equipment to be shared by two or more grades should be kept in some kind of storeroom to which all members of staff have ready access.

It is strongly suggested that kit items should not all be heaped together in a disorganised manner. Separate drawers, shelves, or boxes should be kept for the various segments of the course, and clearly labelled, e.g. plants, animals, heat, light, sound, mechanics, magnetism, electricity, geology. Teachers will find their kits easier to manage if equipment is returned to its proper place after use.

Teachers are reminded that all dangerous materials, such as inflammable liquids, fragile glassware, and poisonous chemicals must be kept locked away out of the *sight* of children.

Items of general use throughout the school have been put into a separate list. Items required for one class only have been grouped in a special list for each of the grades from Third to Sixth. (The kit has not been extended to cover Natural Science for infants' classes, primarily as the materials used here are less structured, and as most of them should easily be found in the child's own environment).

This booklet has been designed to help teachers stock their schools with equipment for the teaching of Natural Science. Although it includes brief references to the uses of items, it is not intended as a teacher's manual. Hosts of appropriate experiments, that can be performed with the simplest of materials, have been properly described in textbooks and manuals such as the UNESCO: *Source Book for Science Teaching*, and Maxine Sale: *A Teacher's Guide to Practical Science in the Primary School*, which was written with the N.S.W. Syllabus in Natural Science specifically in mind.

#### Availability of Primary Science Kits

Several commercial kits are available, but these have a number of disadvantages: they are not designed to meet the needs of the N.S.W. syllabus, they are made of materials that will not necessarily stand up to the wear and tear of children; they contain many commonplace items that are not worth a special purchase, and they are far too expensive. The vast majority of items in the following lists are available at low cost from N.S.W. Government Stores, and schools are advised to use this source as a basis for the building-up of their own kits. A few other sources are worth a special mention. Australian Biological Supplies have, according to their present catalogue, an enormous range of teaching aids covering classification and diversity in the plant and animal kingdoms, plant and animal anatomy and physiology, growth and development, adaptation and ecology, genetics, and geology. They plan to release in 1970 a range of plastic blocks designed for the primary school Natural Science syllabus. If these prove successful they will proceed with their plans to supply in 1971 "a complete Natural Science resource kit for each class from Kindergarten to

Sixth Class". Their address is:

Australian Biological Supplies Pty. Ltd.,  
Cnr. Barney and Crescent Streets,  
Armidale. N.S.W. 2350

Several of the machines mentioned in the mechanics strand of the syllabus can be made up from components in Meccano sets and Lincoln Junior Engineer sets. Parts are available separately in the steel version of Meccano - ask any toy shop for a Meccano Parts List.

N.B. Prices of items available from Government Store are confidential and cannot be quoted. Numbered items mentioned in this booklet are listed in their catalogue for September 1968.



### I. The General Kit

1. A heating device, such as a gas burner, spirit burner, or electric hotplate, is a necessity. Government Stores will supply, upon special request, a "Companion" brand butane burner, consisting of gas tank, regulator, 6 ft. hose, and bunsen. When the tank is empty, it will be refilled by your local Porta-Gas dealer.

The spirit lamp, Government Stores Item 120500, produces a small but hot flame. It is ideal for group work. It should always be placed in a small metal dish or tuna can for safety. (A small bucket of sand should always be on hand in case of fire accidents with fuel burners).

2. Methylated spirit, in 1 gal. tin (G.S. Item 203792) or 5 gal. drum (G.S. Item 203793) is needed for the spirit lamps, for making up iodine solution, to extract chlorophyll from green leaves prior to the starch test, for shifting grass stains on clothing, and for preserving specimens if nothing else is available.
3. A packet of candles and a dozen plastic egg cups (G.S. Item 104055) or patty cake tins make a useful series of heaters. A short length of candle should be set in each container. This is useful for the "bell-jar" experiment, demonstrating that only part of the air supports burning. A row of these devices can be used to show that wire expands when heated.
4. A plastic funnel, to assist in the pouring out of methylated spirit etc., can be obtained for about 10c at any supermarket.
5. A tripod stand, G.S. Item 120689.
6. Two wire gauzes, 6 inch squares with asbestos centre, G.S. Item 120465.
7. Two asbestos squares, to protect table top from heat, G.S. Item 120006.
8. A dozen pyrex test tubes, 6" x 3/4", G.S. Item 120873.
9. Two test tube stands, each with six holes, G.S. Item 120691.
10. Two dozen 250 ml. beakers, in borosilicate glass, G.S. Item 120048. Small saucepans and ovenware can be substituted for beakers.
11. Clothespins, for handling hot glassware. Test tube holders may be obtained from Government Stores upon special request.

12. A dozen corks, 3/4" diameter at base (G.S. Item 120244), for fitting delivery tubing into test tubes.
13. A set of three cork borers, G.S. Item 120115.
14. A set of six 5 ft. lengths of soda glass tubing, 3/16" outer diameter (G.S. Item 120757), for use as delivery tubing. Clear plastic tubing, 3/16" internal diameter, purchased locally, is best for making delivery tubes. Have the glass tubing emerge about 1" beyond the cork, then fit the required length of plastic tubing onto this.
15. A triangular file (G.S. Item 120335), for cutting lengths of glass, and for making iron filings out of nails (horseshoe nails are best).
16. Glass jam jars and coffee jars, with their lids, serve as all purpose containers.
17. Plastic teaspoons (G.S. Item 104666) and paddle pop sticks are used not only as stirrers but also as substitute spatulas for scooping crystals out of bottles.
18. A dozen 100 ml. measuring cylinders (G.S. Item 120304). Narrow necked essence and medicine bottles of various sizes are an adequate substitute. These if over-filled and then brushed smartly across the top with a ruler give a measure of water than can be replicated with surprising accuracy.
19. Two retort stands (G.S. Item 120686) with bosshead fittings (G.S. Item 120123). A reasonable substitute can be made as follows: take a 9" length of coat hanger wire and make a right angle bend 3" from one end, then force this short part through a cork in the neck of a beer bottle filled with sand.
20. The following carpenter's tools are useful: hammer, pliers, tin snips, hacksaw, and screwdrivers (or one handle and several blades).
21. There should be enough gardening implements to keep all members of a class busy at the one time. Weeding handforks, shovels, mattocks, secateurs, watering can, sprinkler, hose and fittings are all available from Government Stores.

Every class should have its own garden plot. If a school wishes to have its own shrubbery consisting entirely of Australian native plants, it should first construct a bed raised 1 ft. above the surrounding level by importing sandy loam or bush sand - to provide the necessary drainage. Consult a nurseryman for a list of windbreak trees and native shrubs suited to local conditions. Blood and bone applied

- lightly is the safest fertilizer to use on Australian plants.
22. Small supplies of bean seeds and wheat grains are needed for examination of seed structure, and for germination, tropism, and fertilizer experiments.
  23. Forty hand lenses (G.S. Item 110510) are needed to allow each child in a class to carry out specimen observations.
  24. Six packets (five blades in each) of safety razor blades, single cutting edge (G.S. Item 104165), are recommended for cutting flowers and seeds lengthwise for examination of structural details. Seeds should be soaked at least 24 hours in advance, so that they can be slit easily. The single-edge blades available for a few cents each from ladies' hair-dressers are better than razor blades because they are stronger, larger and more easily handled.
  25. It is very useful for the school to have several forceps (G.S. Item 120489) in a box, ideally one per child in a class of 40.
  26. Bundles of old newspapers can be used for protecting desks during specimen observations. They can also be used for pressing specimens of native flora, though blotting paper is better. Children should be encouraged to bring from their home gardens native flowers, which can be studied fresh and then added, with notes, to a class book of pressed specimens. Press between sheets of absorbent paper, using the weight of a couple of large books. Change the paper daily for a week.
  27. Classes that decide to keep a pet are usually prepared to buy their own cage and supplies of pet food. Consult local pet shop owner for type of food best suited to the pet.
  28. At least one spring balance is necessary for dealing with the efficiency of model machines. Children using their bare hands find it difficult or impossible to make any quantitative comparisons of the efforts required to shift a load with and without the use of a machine. Increases in length of a stout piece of elastic or tyre tube strip can make quite successful comparisons on small loads, but a yard of 1" wide elastic cannot lift a half-brick without exceeding its elastic limit and extending to nearly 6 ft. Spring balances catalogued by Government Stores are marked in metric units, which make them unsuitable for primary children. Government Stores may obtain spring balances marked in British units at your special request, otherwise you have to buy them direct from the manufacturers. Look up addresses in the Pink Pages under the heading "Scales and Weighing Machines". Two spring balances would be best: a sensitive one to measure small forces up to

- 1 lb. or so, and another that can take the weight of a brick (7 or 8 lb.). For the latter, Tubular Balance No. 15, put out by Salter and Co., 342 Kent Street, Sydney, is ideal, because it measures up to 10 lb. in easily read 1/10 lb. units. Cost is \$7.95 retail, less sales tax. They also sell a cheaper item, Pocket Balance No. 3, for \$2.25. It measures up to 7 lb. in 2 oz. units.
29. A reel of extra strong black thread (G.S. Item 120731) is needed for attachment of loads and efforts to machines. A coil of thin string will substitute.
30. A collection of weights is suggested for use with machines, e.g. a brick, a half-brick, stones, lead sinkers of various sizes, heavy nuts and bolts. A useful weight can be extemporised by putting a pile of sand in the middle of a child's handkerchief and then tying the four corners together with string.
31. It is recommended that every school should have at least one binocular microscope (G.S. Item 120522), to which all children have access. For greater convenience, it is suggested that the microscope be permanently bolted to a Science Table or small desk; only the removable eyepieces in the two oculars need then be locked away in the teacher's cupboard. A plastic cover will keep dust out. This microscope enables children to examine closely a much wider range of interesting things, both living and non-living, than the ordinary monocular microscope. On first thoughts, its price seems high - but actually it is only equivalent to the proceeds of one successful coffee morning!

Microscope slides, cover slips, and Canada balsam for temporary mountings, are all available from Government Stores.

32. A watch glass 4" wide (G.S. Item 120475) has a number of uses. It can be used to expose substances to the air for the absorption of water; it can be used to show evaporation and crystallisation from solution as one of the forms of sedimentation. A saucer can be used equally well for these, but if a watch glass is turned over, its convex surface can be used as a support for magnetised steel strips and electrostatically charged rods for the demonstration of attraction and repulsion.
33. Plastic containers salvaged from the kitchen are excellent for observing the growth of plants, particularly if no garden plot is available. Each container should be punctured for drainage holes, filled with rich sandy loam, and placed in a drainage tray on a sunny ledge. As well, many children should be able to bring plastic and terracotta garden pots from home.

Children in Third Grade should observe the complete growth cycle of plants from seeds, grains (which are really a kind of dry fruit), and bulbs.

Children in Fourth Grade can put potted plants in dark cupboards and refrigerators to find out whether light and heat are necessary for growth.

In Fifth Grade, children can grow seedlings in pots, to show tropisms when the seedlings are exposed to light or to water from one direction only.

Simple photosynthesis experiments are also appropriate to Fifth Grade. For these, small geranium plants in pots, that can be completely enclosed in a plastic bag if necessary, are very useful.

34. Plastic bags in packets of 10 can be purchased cheaply at supermarkets. They are useful in experiments on air pressure, transpiration (collecting condensed water vapour), photosynthesis, and plant respiration.
35. It is very handy to have a good supply of balloons. Inflated balloons can be used to show that a tuning fork is vibrating, that the air inside conducts sounds well, that air expands when warmed, that air exerts pressure, that when the air is expelled the balloon undergoes jet propulsion, and that if the neck is pinched while air is escaping, the squeaky sound produced is the result of a vibration (as in a reed instrument).
36. Iodine solution is needed for starch tests in Fifth and Sixth Grades. Iodine crystals (G.S. Item 221112) are not soluble in water: they should be dissolved in methylated spirit. The solution need not be very concentrated - translucent amber rather than opaque brown. Tincture of iodine is a reasonable substitute. Actually, it is better to use iodine dissolved in an aqueous solution of potassium iodide. Ask your local pharmacist to make this up for you.
37. Caustic soda (2 lb. tin, G.S. Item 104171) has a number of uses: left exposed to the air, it quickly absorbs water vapour, becomes wet, and starts to dissolve; it also absorbs carbon dioxide from the air, so can be used together with a potted plant in a plastic bag to show that the plant cannot manufacture starch in air lacking carbon dioxide; and it gives a strongly alkaline reaction with Universal Indicator.

If Sixth Grade pupils would like to test foods for protein, demonstrate the test first on gelatine or egg white: add a little caustic soda solution, then two drops of copper sulphate solution. The resultant violet colouration is typical of proteins.

If caustic soda is spilt on skin, clothing, or wood, flood the area immediately with water. Mop up with a rag, and then sponge the affected area lightly with a weak acid, e.g. boracic acid (G.S. Item 221006).

38. Calcium hydroxide or slaked lime (4 lb. tin, G.S. Item 221128) is used for making a stock of limewater. Put about 1" of lime on the bottom of a half-gallon jar, then fill with water. Stopper and let stand. Decant limewater off the top as required, and replace with water. Limewater is a safe alkali for neutralising spilt acid that cannot be washed away with water. It can be used to show that carbon dioxide is breathed out by humans, and by plants or plant parts that are not carrying out photosynthesis.

Slaked lime may be used in Sixth Grade's fertilizer tests, though it is better to use agricultural lime (crushed limestone, available from produce stores).

39. Every school should have several bar magnets: 20 pairs would enable each child in a class to experience at first hand the force-field phenomena of magnetism, such as the mutual repulsion of like poles. A cheap source (40c a pair, less sales tax) is:

Chapman's Sports Store,  
98 Railway Street,  
Rockdale. N.S.W. 2216

These are very strong though they are not steel, but the alloy alnico.

Bar magnets should be stored in pairs, with opposite poles side by side, and preferably with a strip of steel at each end to act as keeper.

40. A tuning fork, e.g. middle C, 256 vibrations per second (G.S. Item 120401), is useful in all grades to revise the concept that sound is produced by a vibrating object - touch it to an inflated balloon, water, lips, teeth, etc.

Fifth Grade pupils should discover that a tuning fork can be heard better through the bones of the head than through air.

41. Every school should have a terrestrial globe, to show the shape of the earth, its major physical features, its rotation, day and night, its revolution, the cause of the seasons, the reasons for tropic, temperate, and frigid zones, and the relationship between the earth and the moon.

## II. Special Kit for Third Grade

1. Children should see the whole growth cycle of plants, from seeds, grains, and bulbs, either in the class garden plot, or in well drained plastic or earthenware pots in the classroom.
2. Balls from the sports equipment can be used to demonstrate that force is necessary to start or stop an object moving.
3. Inflated balloons and plasticine can be used to show that force is necessary to change the shape of an object.
4. A small sheet of masonite or similar hardboard propped onto a stack of books will illustrate the inclined plane or ramp. A small weight tied to a piece of elastic when lifted directly from the table to the top of the books will cause the elastic to stretch a measurable amount. If the weight is hauled up the ramp from the table to the top of the stack, the elastic does not stretch so much. If a spring balance marked in British units is available, they can repeat the experiment, taking actual readings of the forces involved.

Several sheets of hardboard of varying lengths would be preferable, to show that the steeper the incline, the greater the effort required.

5. A box of 20 coloured pencils will provide an example of rollers as a machine. Drag a brick along the floor with a 1 yard length of 1" elastic; measure the increased length. Put 3 pencils under the brick and space the rest in front of it at 2" intervals. Haul the brick along and note the lessened effort.

A dowel rod cut into several short lengths will also provide a set of rollers.

6. To demonstrate the principle in the use of ball bearings, place 20 marbles (12 cents' worth) in the groove on a paint tin between the lid and the outer flange. Invert another paint tin the same size and lower it onto the marbles. Place a brick on the inverted tin and spin the load. Remove the marbles and try again.

Golden syrup tins can be used instead of paint tins.

7. A small ball race plus ball bearings can be obtained free from your local garage. Ask them to save you the next one they have to replace.

Also, children can be shown ball bearings at work if the front wheel of a bicycle is partly undone.

8. A wheeled toy dragged first on its side and then on its wheels (using elastic or spring balance) will show the advantage of the wheel and axle.
9. Children should also be shown a toy with a spoked wheel attached. (Wooden wheels and spokes are available from Tinker Toy). After establishing that a single spoke will do instead of the whole wheel, examine an example of a "handle and axle". A desk pencil sharpener can be used for this. Strip off the shavings holder and the cutting blades. Tie a string from a weight on the floor to the axle. Turn the handle and raise the weight. Many toys and kitchen utensils have handles and axles.
10. A guitar or similar stringed instrument should be readily borrowed to demonstrate that the thinner the string, the tighter the string, and the shorter the vibrating part, the higher the note.

A substitute can be made using a block of hardwood about 15" long. Buy 3 nylon strings at a music shop (or use fishing line), two thin, one thick. Screw a brass cup-hook into the board 1" from one end. Attach one of the thin strings firmly to the cup-hook, then pass it over the other end of the board and tie it to a 1 lb. weight. Screw two other cup-hooks 4" from the first end. Tie the thick string and the other thin string to these, pass them over the other end of the board, and tie a 1 lb. weight to each of them. See diagram opposite.

Compare the notes: from two strings, same length, same tension, different thickness; from two strings, same thickness, same tension, different lengths.

Steady the board with one hand while pushing on a weight with the other hand. Note the effect of increased tension on pitch.



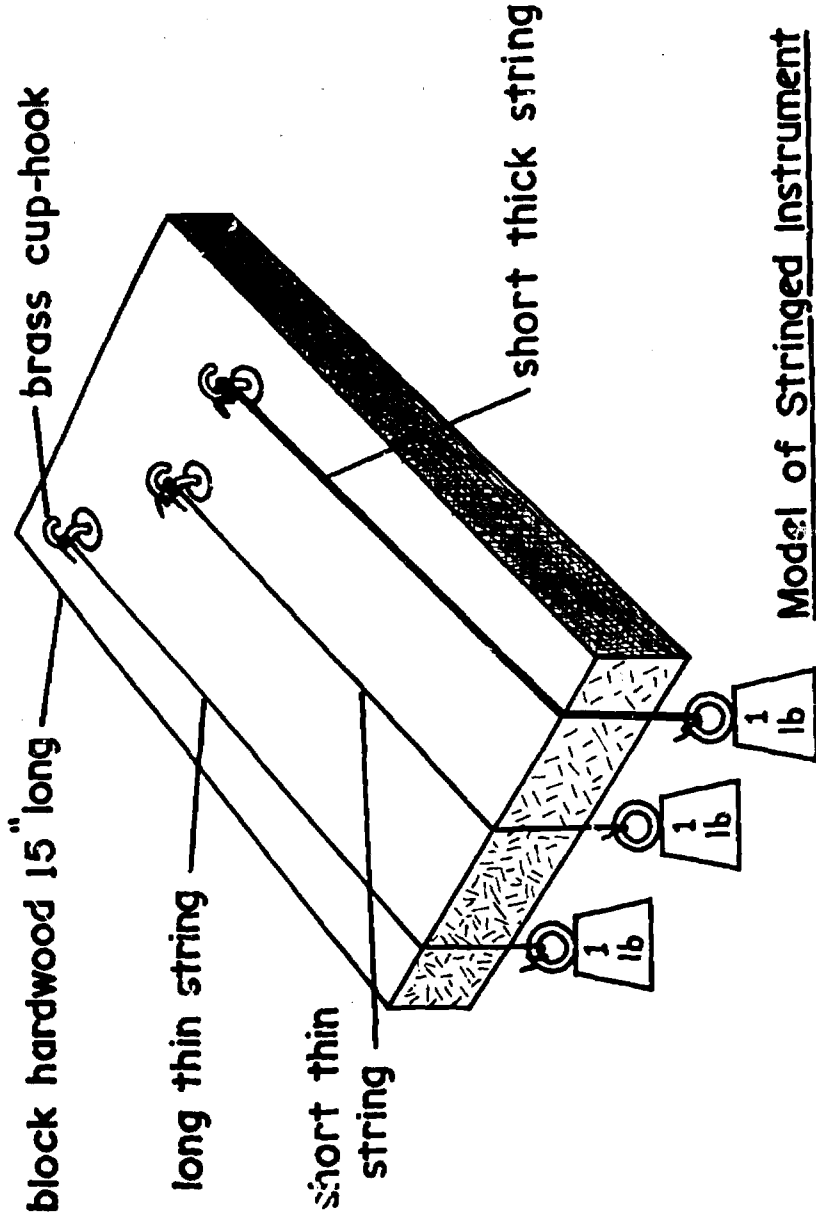

### III. Special Kit for Fourth Grade

1. A collection of mollusc shells is useful, particularly if children are going to study adaptations and interdependence of seashore organisms in Fifth Grade. Children should be able to recognise shells of:
  - a) typical univalves - limpets, periwinkles, whelks
  - b) typical bivalves - oyster, mussel, pipi
  - c) cuttlefish, adapted to act as a skeleton
  
2. A collection of preserved invertebrates, covering those types not immediately available in the locality, is recommended. The most humane way to kill animals is to use town gas. A few drops of ethyl acetate (G.S. Item 221086) in a bottle is also humane, and leaves the specimen pliable enough to be spread out as required for mounting. Care: ethyl acetate is inflammable. Ether is humane, but it leaves specimens' appendages rigid and brittle. Teachers should prepare their specimens out of the sight of children.

If you want an animal, e.g. snail, to die with delicate parts extended, narcotise it with tobacco juice: use an infusion prepared by soaking the contents of a few cigarettes in hot water.

To improvise a killing bottle at home (if gas is unavailable), put a chlorine-smelling bleach or disinfectant in the bottom of a screw-top jar and add a small quantity of vinegar. Cover with a layer of cotton wool. Put the animal in, screw on the lid, and leave jar to stand for a few minutes in hot water.

Animals with little flesh, such as centipedes, spiders, and sea stars, may be preserved by drying in a slow oven. Natural colour is maintained, but delicate parts such as the tube feet of sea stars shrivel up.

Methylated spirit and diluted formalin have their limitations as preservatives: natural colour is lost, parts become brittle, and watery juices are often extracted from fleshy animals, producing a cloudy mixture which obscures the specimen.

The best liquid preservative is probably 1 part glycerine (G.S. Item 221105), 1 part commercial strength formalin (G.S. Item 221099), and 8 parts water. Specimens retain suppleness and colour (if kept away from light).

Use bottles with plastic screw-top lids, as steel lids are rapidly corroded.

Animals and native flora can be preserved in remarkably lifelike form in moulded blocks of clear polyester resin. Blocks may be handled many times without damage to the specimens. If scratched, the blocks can be polished smooth again. Tins of the resin, plus hardener, are put out by several firms, e.g. Monsanto Chemicals, and can be purchased at most Art and Craft shops.

Best results are obtained if the specimens are first dehydrated. Desiccating agents appropriate for different kinds of specimen are listed in the literature that comes with the resin and gives instructions for the whole process. The desiccating agents may be purchased through your local pharmacist. Natural colour of the specimens may be preserved indefinitely if the blocks are stored away from light.

It is handy to have a supply of small cardboard boxes to act as moulds.

Plastic embedded specimens, covering examples of nearly all the major groups in the animal and plant kingdoms, are obtainable, at prices ranging from \$1.50 - \$2.00 per specimen, from

Australian Biological Supplies,  
Crescent and Barney Streets,  
Armidale. N.S.W. 2350

3. A collection of seeds and fruits is useful, to show the different methods of seed dispersal.
4. A collection of vegetative reproduction organs in plants can be built up each year - bulbs, corms, tubers, rhizomes, and stem bases with swollen tap roots or tuberous roots attached.
5. The Fourth Grade Kit should have its own collection of bar magnets, if these are not to be found in the General Kit.
6. Oddments of the following metals should be available to demonstrate that iron is the only metal attracted by magnets: aluminium (milk bottle tops or "silver" wrapping foil), zinc (cut some off the case of a worn out dry electric cell), cast iron, steel, lead, and copper. (Solid gold and silver jewellery can be borrowed temporarily). Some galvanised and plated materials (e.g. scrap of roofing iron, jam tin, chrome fitting, "silver" teaspoon) should be present to show that they have a core of steel. (Steel may be regarded at this stage as a purified form of the iron that originally comes out of the blast furnace, cast iron as the original unpurified form).

7. Iron filings may be collected free from a joinery, or bought from Government Stores, Item 221116. Two pupils with a file each, a large sheet of newspaper, and some large nails can make enough filings in a lunch hour. The filings are needed to show that a magnetic field has a definite shape, and that the magnetic force of a magnet is concentrated at the poles.
8. A horseshoe magnet shows the added steel-lifting power obtained by bringing the two poles close together. Its magnetic field is different from that of a bar magnet.
9. A horseshoe magnet plus strips of hard steel (such as 3" lengths of hacksaw blade or steel knitting needle) may be used as a substitute in the absence of permanent bar magnets. Stroke (do not rub back and forth) each steel strip with a pole of the horseshoe magnet. The resultant bar magnet will hold its magnetism for some considerable time - long enough to complete the topic. In any case, these strips should be available so that children can find out how to make their own, and to use them in individual work. (Bought magnets have a habit of disappearing). The same strips can be used all over again if they are first demagnetised by heating or hammering.
10. A number of bar magnet cradles should be made up and kept in the kit. Make a hole in a strip of paper  $\frac{1}{2}$ " wide. Pass a fine thread through the holes, draw the ends together, and tie. The loop of paper becomes the cradle. Suspend it on about a foot of thread. When a bar magnet is slung in the cradle, it will come to rest pointing magnetic north and south. (The thread must have no tendency to twist). Thus the hitherto unknown poles of a magnet can be determined, and the principle of the directional compass demonstrated.
11. Balls borrowed from the sports equipment may be used to demonstrate that a force is necessary to accelerate, retard, or change the direction of a moving object. A ruler applied to a rolling ball will demonstrate braking action.
12. Talc powder may be used to demonstrate the use of powders as lubricants, e.g. in surgeons' gloves and on dance floors.
13. A small windlass may sometimes be found on a toy tow-truck. A windlass can be made up from the appropriate Tinker Toy materials, available in toy shops. Basically, a windlass is a load-hoisting version of the wheel and axle, in which the axle is mounted horizontally. A working model of a windlass is easy to make. For a good, solid base, take a piece of wood 4" wide and about a foot long. For uprights use two slats of packing case pine, exactly the same length - about 8". Into one end of each, cut a slot about  $\frac{3}{8}$ " wide, or better, bore a  $\frac{3}{8}$ " hole in each, 1" from the end. Nail the

uprights to the base. Push a new pencil through a cotton reel; very conveniently, it fits snugly. Rest the pencil across the slots in the uprights (or pass it through the holes). Tie very firmly a thread to the pencil (axle), pass it a few times around the pencil, then tie it to a weight resting on the base (or on the floor). Tie another thread firmly to the cotton reel (wheel or barrel), then pass it many times around the reel. This is the effort string: when it is hauled in, the wheel and axle are rotated, and the load is lifted. When the load is lowered, make sure that the effort string is re-wound onto the barrel. Using either a spring balance or the amount of stretch in a stout piece of elastic, measure the force needed to lift the load directly off the floor. Compare this with the force needed to pull the effort string.

Make a handle and axle version, which is the kind of windlass in everyday use. Bind one end of a 5" length of wire to a pencil, and twist the other end into the shape of a handle. The same frame can be used for both versions. See the diagrams.

14. A capstan is a wheel and axle in which the axle is mounted vertically. A cotton reel can be used to represent the barrel in a model capstan. Drive six  $1\frac{1}{2}$ " nails into the cotton reel to represent the capstan bars (spokes). Place the reel over a 3" nail that has been driven up through a solid piece of wood. Tie thread so firmly to the cotton reel that it will not slip. Place the model capstan on the edge of the table. Tie the other end of the thread to a weight on the floor. When the bars are turned, the thread is wound onto the barrel, and the load is hauled up. See diagram.

A larger, stronger model can be made using a large wooden spool, upon which thread or copper wire has been wound. Drill holes into this and use short knitting needles as demountable capstan bars. Use a piece of dowel rod as the vertical axle. Drive a small nail up through the base board, place one end of dowel rod on the t'p of the nail, then belt it into place with a hammer.

Capstan blocks can also be made up using appropriate Tinker Toy materials.

15. A set of three squares of cardboard, with a small hole in the middle of each, will show that light travels in straight lines. A lump of plasticine is a convenient means of supporting each square.
16. A pin-hole camera, by showing that light travels in straight lines, explains the principle of the camera obscura.

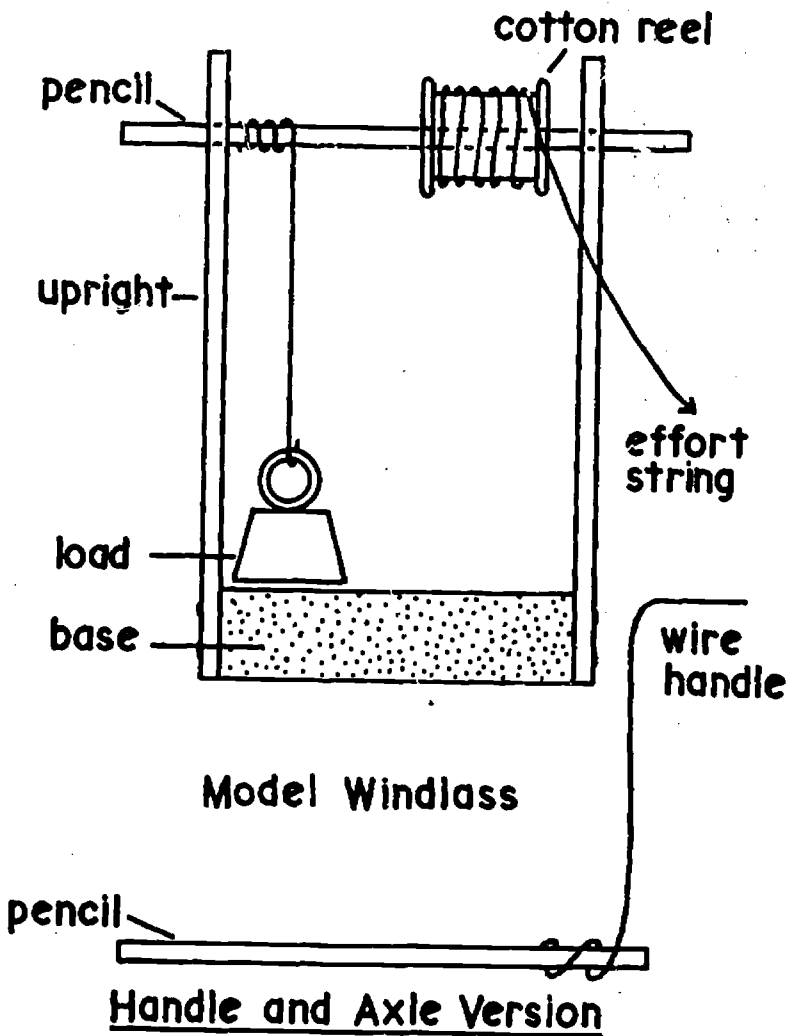

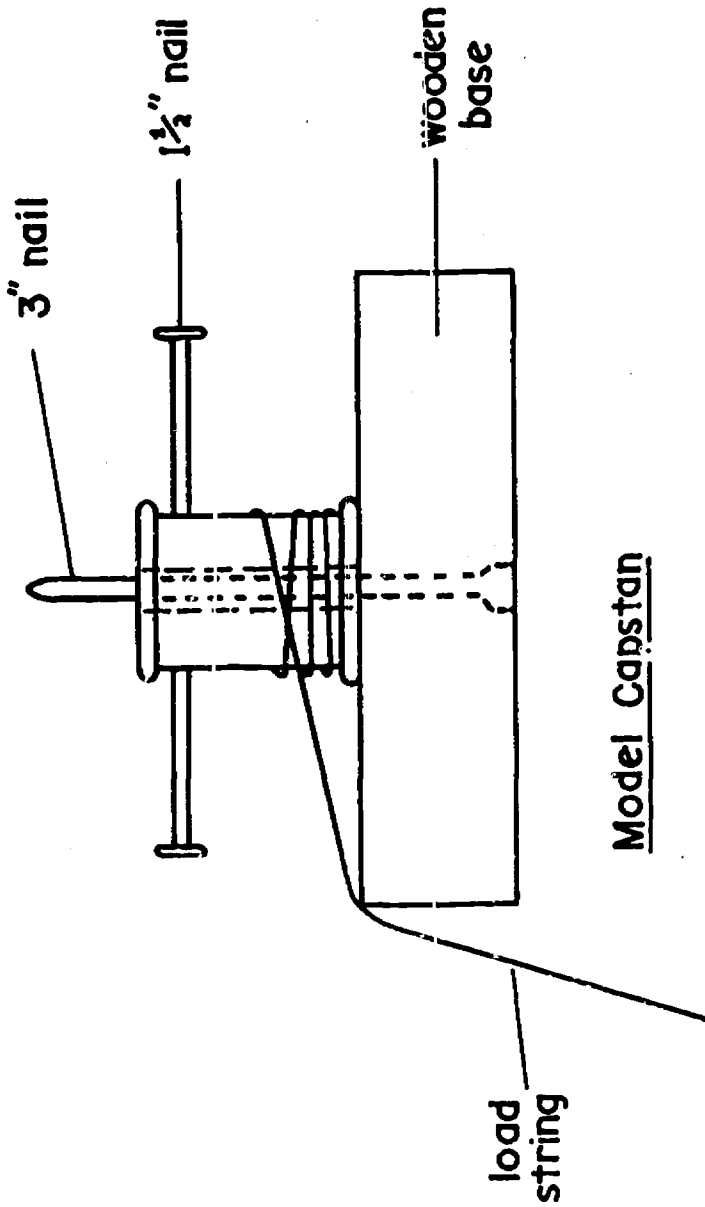

Model Capstan

17. Plane mirrors, 6" by 1", mounted on bases, can be obtained from Government Stores, Item 120525. These show that the angle of incidence equals the angle of reflection. Place a mirror on a sheet of paper, and rule a line up to it, representing the path of an incident ray of light. Then rule another line along its reflection, to represent the path of the reflected ray. Rule in a perpendicular at the point of reflection, and measure the two angles thus formed.
18. Several, at least eight, Fahrenheit thermometers (G.S. Item 120722) are needed, for examination of the parts of a thermometer, for practice in reading temperatures, and for experiments with heat.

Fourth Grade pupils are expected to keep enough daily temperatures at least to be able to show significant differences in the seasons.

19. A simple device for measuring the force of winds is sometimes available in toy shops. Wind enters the base of a clear plastic cylinder and lifts a float. The stronger the wind, the higher it lifts the float. It costs about a dollar.
20. Substances which may be used to absorb moisture from the air include: table salt, caustic soda (or soap powders and toilet cleansers that contain caustic soda), a cobalt salt, and granules of silica gel. Weather forecasting novelties are often impregnated with a cobalt salt: blue - dry weather; pink - damp weather. Granules of silica gel, also impregnated with a cobalt salt, are often found in the lids of biscuit tins and in bottles of tablets sold by pharmacists. Your family chemist may give you a handful of the granules free. Each time these granules turn pink, they can be gently heated till they turn blue. In this way, they may be used over and over again. Self-indicating silica gel granules are also available from Government Stores, Item 221206.
21. Plants from the school aquarium may be used to demonstrate the presence of root hairs on roots.



#### IV. Special Kit for Fifth Grade

1. Universal indicator (G.S. Item 221240) is necessary for establishing the degree of acidity (or alkalinity) of soil: this is one of the most important physical characteristics to be considered in studying the natural habitats of plants. Children will have to become familiar with the colour range of universal indicator, as shown on the label: red, orange, yellowish-green, green, blue, and violet indicating respectively strongly acidic, moderately acidic, faintly acidic, neutral, faintly alkaline, moderately alkaline, and strongly alkaline. Tests should be carried out on common acidic substances, e.g. vinegar, cordials and fruit juices, and on common alkaline substances, e.g. caustic soda, bar and powdered soaps, ammonia cleanser, and limewater. Sea water turns universal indicator green, so seashore organisms are adapted to live in a faintly alkaline environment.

Take a sample of white vinegar, add a couple of drops of indicator, then add a dilute alkaline solution a little at a time: with luck you will get the whole colour range from red to violet.

The colour changes in the reverse order can be shown dramatically by taking a large jar of water containing a trace of alkali and a squirt of universal indicator and dropping in a few lumps of "dry ice". The bubbling, fog-making mixture goes through the whole array of colours from violet to red.

N.B. As a memory aid, note that the colour range for universal indicator from acid to alkaline follows the order of colours in the spectrum of sunlight.

2. A collection of small rods of various materials is useful to show their different abilities to conduct heat, e.g. knitting needles of aluminium, steel, and plastic, steel and wooden skewers, a solid glass rod (1 lb. bundles are available from Government Stores), steel coathanger wire and copper wire. Smear the rods uniformly with vaseline ( $\frac{1}{2}$  lb. bottle of soft paraffin G.S. Item 221173). Make a loop in a length of string and attach the other end to a clamp stand or substitute. A child passes 3" of a rod through the loop and holds it there. Another child sticks drawing pins to the vaseline-smear rod. A candle flame is so placed that it just touches the end of the rod, which is then held in place until vaseline ceases to melt and drawing pins have stopped falling off.

Repeat the experiment with each different kind of rod. Vaseline will melt furthest along the metal rods because

these are good conductors of heat. See Photograph No. 1.

3. Place a metal spoon, a plastic spoon and a wooden paddle-pop stick in a cup of boiling water. Note that plastic and wood are good insulators.
4. A colouring agent such as ink, potassium permanganate, or cake colouring is useful to show the convection of heat in water, though boiled tea leaves in water heated in a beaker show the formation of convection currents very well.
5. Several jam tins, all exactly the same size, and painted in various ways, can be used to show that shade and texture of a surface affects its heat absorbing properties. The number of tins that can be used would depend upon the number of Fahrenheit thermometers available. As an absolute minimum one needs two tins: one with its ordinary polished silvery surface and one with a dull black surface (e.g. coated with soot by rotating it slowly in a candle flame). It is much better to have in addition tins painted as follows: bright red gloss, bright green gloss, pale blue gloss, dark blue gloss, dull matte grey, and gloss black.

Using a measuring cylinder or essence bottle, put exactly the same small quantity of water in each tin, add a thermometer, then place all the tins exactly the same distance in front of an electric radiator for exactly the same length of time. Measure the rise in temperature of the water in each tin.

It is worthwhile carrying out at least one fairly elaborate experiment such as this with Fifth Grade pupils, to provide an opportunity for the discussion of controlled experimentation. Then at the conclusion of this experiment the children can be invited to discuss reasons why even this investigation falls far short of the scientific ideal.

6. About 3 ft. of bare copper wire may be used to show that a metal expands when it is heated (1 lb. packet of bare copper wire is G.S. Item 221072). Slip a pair of scissors onto the wire, then firmly tie each end to a stand. The tip of the scissors should just swing free of the table. Have the wire as low and as tight as possible. Heat it with a row of candles fixed in plastic egg cups. The tip of the scissors comes to touch the table. It pays to rehearse this experiment before the lesson.
7. Glass tubing, 3/16" diameter, also finds a use in the experiment showing the expansion of coloured water. Press a cork bearing a long piece of glass tubing into the neck of a bottle filled with coloured water. Heat on a tripod and gauze.

No. 1 Conduction of heat along a glass rod with makeshift materials

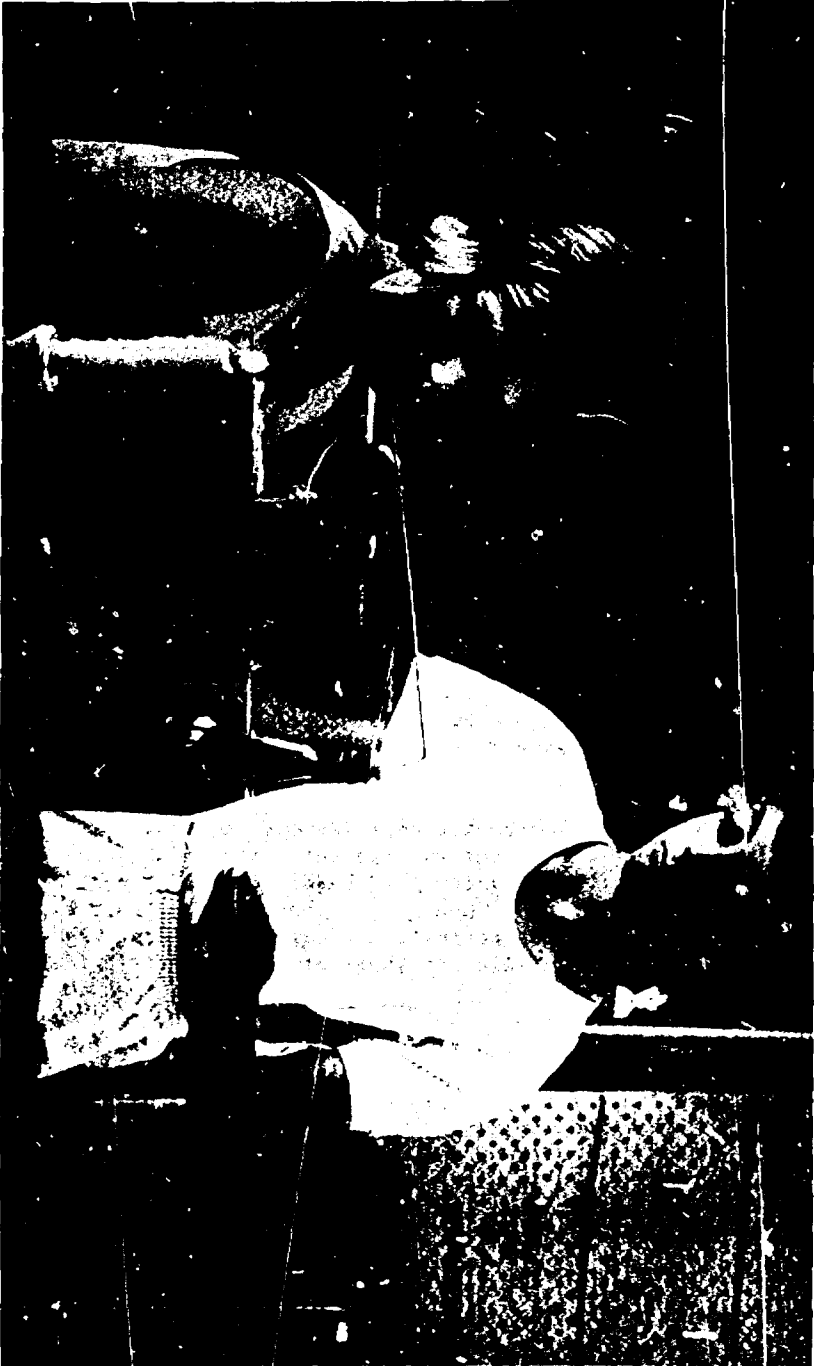

8. Plastic rulers and the plastic barrels of ball-point pens become negatively charged when rubbed with a piece of flannel. A perspex rod rubbed with a scarf of pure silk becomes positively charged; it takes this charge very readily. Perspex rods 9" x 3/4" x 3/16" at 5c each are available from:

Mr. R. Muggleton,  
Science Club,  
Meadowbank Boys High School

9. Pith balls, for showing attraction and repulsion of electrostatic charges, are obtainable from Government Stores, Item 120012. Suitable substitutes are pieces of cork or snips of basket cane just large enough to be conveniently tied to a length of fine thread. Sawdust from the chalkbox is also very good for electrostatics experiments.
10. A toy tow-truck with a true pulley at the end of the winch is excellent for demonstrating the use of the single fixed pulley. Try to find a working model which involves a whole series of simple machines: the tow-rope, after passing over the pulley in the winch, is wound onto a windlass turned by a set of gears which are themselves connected to a wheel and axle turned by the operator!
11. Pulleys of various kinds may be bought in toy shops, e.g. Meccano sells a 3" diameter steel pulley for 29c.
12. Satisfactory pulleys may be made out of cotton reels. The deeply recessed wooden type is best. If you have a barrel-shaped cotton reel, it will carry thread more successfully if you cut a deep groove into it with a pocket knife.

Pass some stout fencing wire through the reel, then twist the ends securely together. Make the knot secure, otherwise the wire may slip and jam the pulley when it is being used to lift a heavy load. See diagrams.

Cut-down wire coathangers make excellent supports for cotton reel pulleys. Cut the wire on each side a few inches from the base of the hook. Bend the ends inwards until they form an axle for the cotton reel. Note the construction of these in Photograph No. 2, which shows how the mechanical advantage gained by the use of a movable pulley can be combined with the convenience of a downwards pull for the operator by the use of a fixed pulley.

13. The true crane differs from the winch in being able to displace its load horizontally as well as vertically. Model cranes can be constructed using Meccano and Lincoln Junior Engineer materials.

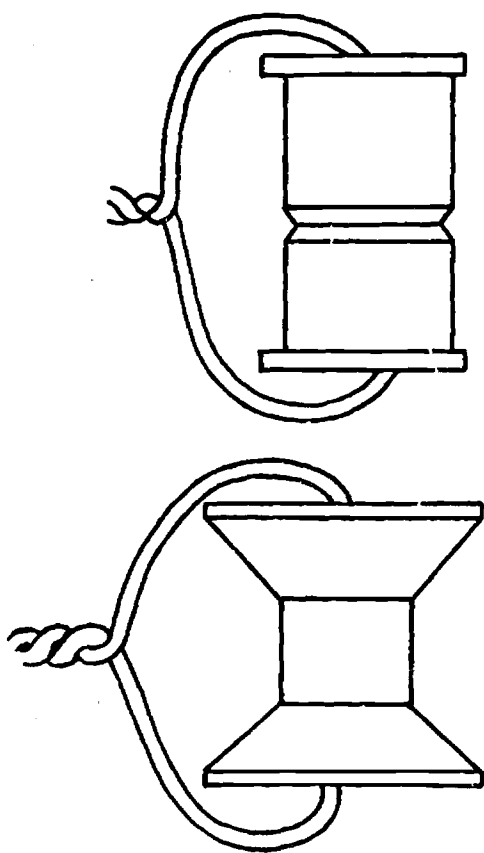

**Pulleys made from cotton reels and strong wire.**



No. 2. A pulley system made from cotton reels and coathangers.

14. The block and tackle is a pulley system. It consists of: a block of pulleys attached to a support; a block of pulleys attached to the load to be shifted; and a long rope or tackle wound around all the pulleys, with one end in the hands of the operator and one end tied to one of the blocks. Blocks of three pulleys each are obtainable at Government Stores, Item 120519.

The principle of the block and tackle can be demonstrated in a quite spectacular way with two smooth 18" rods (e.g. two halves of an old broom handle) and a 15 yd. length of luggage rope, clothesline cord, or canvas-blind cord. The tackle is tied to one end, then wound around the two of them about ten times. One small pupil hauling on the tackle can draw two large pupils on the rods together, no matter how hard they resist. See Photograph No. 3.

15. A maximum and minimum thermometer (G.S. Item 120725) may be used to give daily temperature readings over two contrasting three-week periods in the year.
16. A demonstration model aneroid barometer, with its working parts exposed, may be purchased from Government Stores, Item 120017. If you intend to use an aneroid barometer for weather readings, don't forget to adjust it for altitude. Set it at 30 on a fine day, or better still, set it from a local radio or TV weather report, or by making a phone-call to the local meteorological station.
17. A plastic rain gauge is available from Government Stores, Item 120466. If you don't want the trouble of keeping daily weather records, visit the local weather station and take a copy of weather figures for two contrasting samples of the local district's climate. A three-week sample should be enough. Fifth Grade pupils should be capable, as an exercise in practical mathematics, of converting the figures into graphs and drawing the appropriate generalisations.
18. The hand lenses used for specimen observation may be used to study the properties of a lens, but a large unmounted lens is better (a pair, G.S. Item 120503).
19. Naphthalene (1 lb. packet G.S. Item 104105) is easily crystallised by cooling of the molten state, thus demonstrating the formation of igneous rocks.
20. A solution of copper sulphate (G.S. Item 221074) evaporated till almost dry will show how a sedimentary rock may be formed by crystallisation from solution. Evaporation of a solution of table salt will show how rock salt is formed.

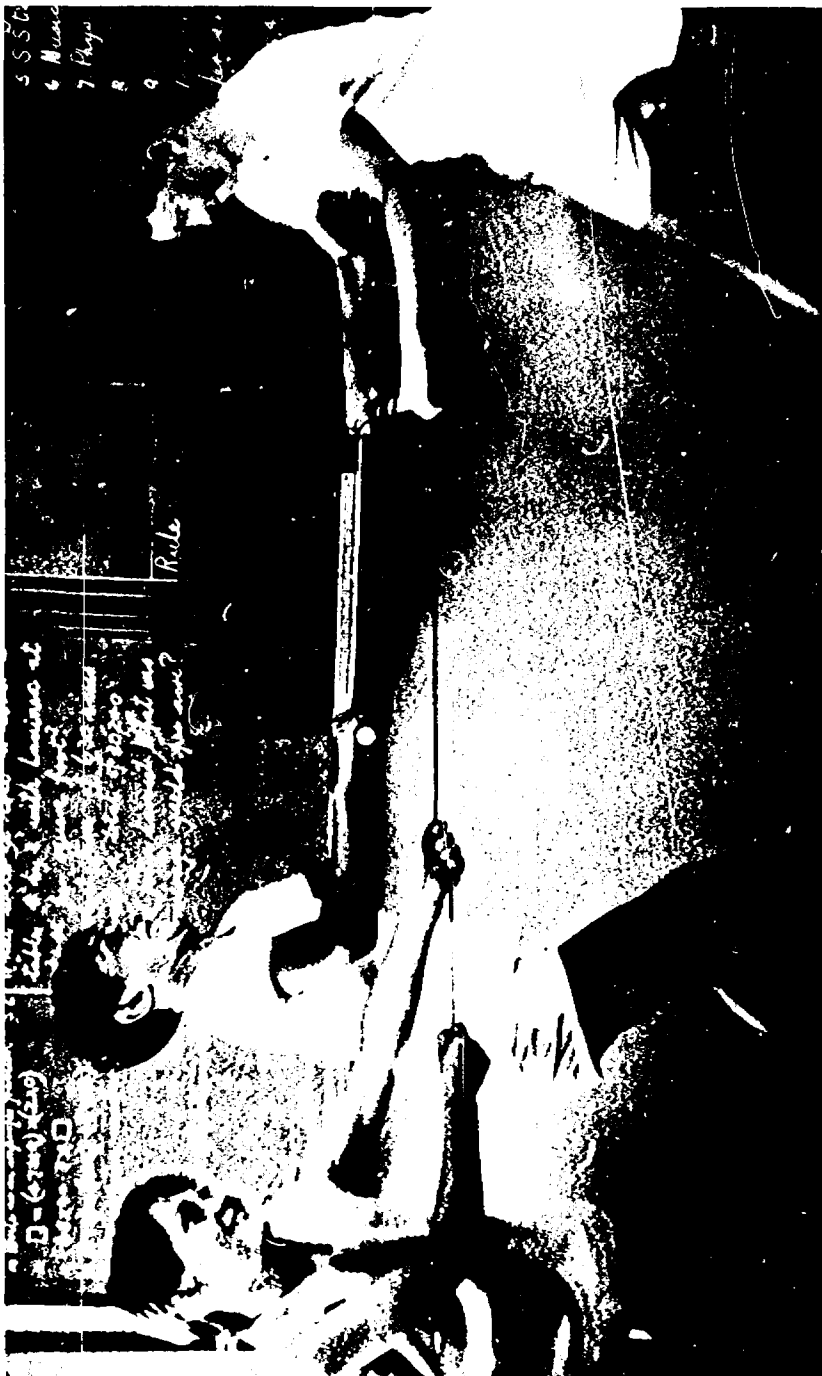

No.3. The principle of the block and tackle.



21. A collection of the following mineral and rock types is suggested, with common examples:

ore-forming minerals (e.g. haematite, bauxite, chalcopyrite, sphalerite, galena - respectively the ores of iron, aluminium, copper, zinc, and lead);

rock-forming minerals (e.g. quartz, mica, felspar, calcite);

plutonic igneous rocks (e.g. granite);

volcanic igneous rocks (e.g. basalt);

sedimentary rocks (e.g. sandstone, shale, limestone, conglomerate, coal, petrified wood, limestone bearing shell fossil, shale bearing plant fossil);

metamorphic rocks (e.g. quartzite, slate, marble).

Stonemasons have chips of marble and granite. Slate and sandstone are available from people who sell flagstones. Many beach pebbles are impure forms of quartz. Mica is used as toaster reflectors - ask for some at an electrical repair shop. The blue metal used on roads is a form of basalt.

The above collection of 22 specimens of minerals and rocks may be obtained from:

Mr. R. Muggleton,  
Science Club,  
Meadowbank Boys High School

together with detailed notes on the specimens, for \$2.50, freight included. Individual samples may be obtained for about 8c each.

22. An aquarium with a properly balanced community of plants and animals is an excellent way of demonstrating interdependence of plants and animals, and to illustrate the concept of balance in nature. Tanks, aerators, aquatic plants and animals are all available from pet shop owners, who should be able to advise you on how to establish your aquarium. It is simple to introduce representatives of the following nutritional categories: photosynthesiser, herbivore, filter feeder, and scavenger - a carnivore would be rather more difficult!
23. Iodine solution is needed to show the presence of starch in plant storage organs, and to test for the presence or absence of starch in photosynthesis tests.

N.B. Leaves and other coloured plant parts must first be decolourised by soaking in methylated spirit before the

iodine test is carried out, otherwise the purple colour does not show up clearly.

24. Laundry starch in granule or colloidal form is useful for demonstrating the distinctive reaction starch gives with iodine solution.
25. A plastic toy "trombone" with a sliding plunger is readily available in toy shops, for about 60c. It shows that vibrating columns of air of different lengths have different pitches.

### V. Special Kit for Sixth Grade

1. A simple current detector is necessary to show that various kinds of electric cell produce electric currents. (Ammeters and voltmeters are very expensive, their components are not visible, and pupils cannot understand how they operate).

First establish the principle that wires carrying electric currents are surrounded by a magnetic field: connect the positive and negative terminals of a dry cell (a known source of current) with a length of copper wire, bring a magnetic compass up close to the wire, and note the deflection of the needle.

Wrap insulated copper wire fifty times around the four fingers of your hand, producing a flattened coil. Bind the loops of the coil together with sticky tape. Strap the coil upright onto a piece of board or cardboard. Insert a scout's compass (or magnetic compass, G.S. Item 120225) into the coil. Have the coil pointing east-west, so that the compass needle is clearly visible pointing N - S. Connect the loose ends of the coil to the suspected source of current. If current is flowing, the needle is deflected. This makeshift current detector is much more sensitive than the pea globe generally used.

In Photograph No. 4 opposite, the "homemade" current detector is connected to a simple wet cell, consisting of dilute sulphuric acid, electrodes of zinc strips and copper (boat nail), and a conducting wire to complete the circuit.

Note the alligator clips connecting the copper wires to the electrodes. These are ideal for making all electrical contacts - available at Government Stores, Item 120221.

2. Insulated copper wire may be purchased from Government Stores, Item 120901.
3. Electrodes are needed for the setting up of wet cells, and for examining electroplating and other electrolysis reactions. Zinc strips cut off a spent torch cell, steel nails, copper boat nails, and even large brass screws make suitable electrodes.
4. Usually, dilute sulphuric acid and zinc and copper electrodes are the components used to demonstrate the principle of the simple wet cell. Commercial sulphuric acid (G.S. Item 221018) is much too concentrated and very dangerous. Store it on a saucer in a safe place. Dilute it by slowly adding one part of acid to six parts of water, stirring continuously with a glass rod.



No. 4. A simple wet cell connected to a makeshift current detector.

5. A spent dry cell sawn in half lengthwise with a hacksaw is useful for demonstrating the cell's components.
6. Collect a worn out car or motor cycle battery from a garage or battery shop. Make sure all sulphuric acid has been carefully drained out. Break off one side of the storage battery with a hammer, exposing its parts: a row of cells with alternating lead and lead peroxide plates in each. Emphasise that the great advantage of the storage battery is its reversible chemical action: it is readily recharged after use.
7. For demonstrating the basic principle of all mechanical generators of electricity you need a coil of insulated copper wire, a bar magnet, and relative motion between these two: it doesn't matter whether you keep the magnet still and jiggle the coil back and forth over it, or vice versa. Have the ends of the coil connected to your homemade current detector by means of alligator clips.
8. A push bicycle generator can be purchased for a little over a dollar. Don't attempt to borrow one from a pupil's bicycle for dismantling, as you will have to break a soldered connection between the wire and the generator's metal frame.
9. The dynamo (any mechanical generator may be called a dynamo) used in the old crank-type telephone may be purchased cheaply at a disposals store. A model dynamo, mounted on a stand together with a pea globe, is available from Government Stores Item 120328, but it must be spun very fast to light up the globe, and it is very expensive.
10. Three dry cells (G.S. Item 109180) connected in series (negative to positive, negative to positive) constitutes a  $4\frac{1}{2}$  volt battery suitable for conducting experiments on the heating and lighting effects of electric currents. Note the correct usage of terms: one of the components of a battery is a cell; a battery is a row of cells.
11. Resistance wire, for showing the heating effect of a current, is available from Government Stores, Item 120902. Fine steel picture frame wire is an adequate substitute.
12. Very fine grade fuse wire, which melts when overloaded with current, may be purchased from local electricians.
13. Steel wool, connected to the  $4\frac{1}{2}$  volt battery, glows red hot, showing that both heat and light energy are produced.
14. A simple electromagnet may be made by wrapping insulated copper wire around a 6" nail. Connect the copper wire to a

dry cell via alligator clips. It won't lose all its magnetism as soon as the current is switched off, but if it is loaded with iron filings, dressmaker's pins, or tacks, it will drop some of them off. It is better to use a rod of soft iron (G.S. Item 120329). An electromagnet for 4 to 6 volts may be purchased from Government Stores Item 120330, but it is expensive.

15. Copper sulphate (1 lb. bottle, G.S. Item 221074) is needed for electrolysis experiments. With the  $4\frac{1}{2}$  volt battery, two copper (nail) electrodes, and a solution of copper sulphate, the principle of the electrolytic purification of metals is illustrated: an impure copper bar connected to the positive dissolves, pure copper is deposited on the negative electrode, and impurities collect in the solution.

If an electrode of another metal (e.g. a nail or teaspoon) is connected to the negative, it becomes coated with copper - the principle of electro-plating.

N.B. Don't put an object made of another metal into a solution of copper sulphate unless it is connected up for electro-plating: otherwise displacement may occur - copper may be deposited allright, but the object may begin to corrode away!

16. For fertilizer experiments, one ought to try at least sulphate of ammonia (a leaf promoter), superphosphate (a root and fruit promoter), and agricultural lime (a soil conditioner). Suitable plants to use would be wheat, carrot, a legume (such as beans or clover), and winter tomato if frosts are no problem. Ideally, the experiments should be begun in autumn and evaluated in spring, and they should be carried out on a 12 ft. square plot marked out into a checkerboard pattern with string. See illustration.

Fertilizers should be added regularly in small amounts. Sulphate of ammonia should always be dissolved in a large quantity of water before addition.

If no garden plot is available, the experiments can still be carried out successfully in the classroom.

It is fascinating to sprinkle sulphate of ammonia on the lawns in the form of the school's initials in large letters: water with a sprinkler until the fertilizer has completely dissolved. Keep the area well watered for a couple of weeks, and the initials will appear as dark green letters.

17. Iodine solution is needed to test for starch - the presence or absence of starch in a variety of foods.

	Wheat	Carrots	Clover	Winter Tomato
Sulphate of Ammonia				
Crushed Limestone				
Control (no fertiliser)				
Superphosphate				

Sulphate of  
Ammonia

Crushed  
Limestone

Control  
(no fertiliser)

Superphosphate

18. The test for simple sugars requires Fehling's Solutions A and B (G.S. Items 221089 and 221090 respectively). The test should first be carried out on glucose (G.S. Item 203305) before being applied to foods.

N.B. Sucrose (table sugar) is not a simple sugar and will not respond to the test.

If sucrose is boiled for a few minutes with dilute sulphuric acid, it breaks down to simple sugars. If the acid is first neutralised with an alkali, the solution will then respond to the Fehling's test.

19. Simple materials are needed to show respiration in plants: a small potted plant covered by a large jar of glass or clear plastic, which is inverted into water in a basin - the lot left to stand in a dark cupboard for a few days. All the oxygen will not be used up, but enough will have gone to provide evidence to refute the commonly held misconception that plants do not "breathe in" oxygen.

Also in a dark cupboard, enclose in a large plastic bag a small potted plant and a small saucer containing clear limewater. Leave a similar saucer with clear limewater outside the bag. Compare after a few days. The limewater that was inside the bag will be much cloudier than that outside, providing evidence that the plant "breathed out" carbon dioxide.

Similar breathing experiments should be carried out with living non-green parts of plants, e.g. ripe fruit, storage organs, flowers.

N.B. Plant respiration and animal respiration are basically the same kind of process. Plants breathe continually, but at a very slow rate. In the presence of sunlight, the green parts of plants also carry out photosynthesis, "absorbing" carbon dioxide and "giving out" oxygen. This is a faster process than plant respiration, so that the gaseous exchange associated with it masks the breathing process that is going on at the same time.

Primary school teachers would do their pupils (and high school teachers) a great service if they stopped teaching them that "plants breathe in carbon dioxide and breathe out oxygen".

20. The following device can be used to demonstrate all three types of levers. To a board 6" long by 2" wide, nail two uprights which each have a hole bored 1" from the top. Bore a similar hole, through which a 3" nail can easily slip,



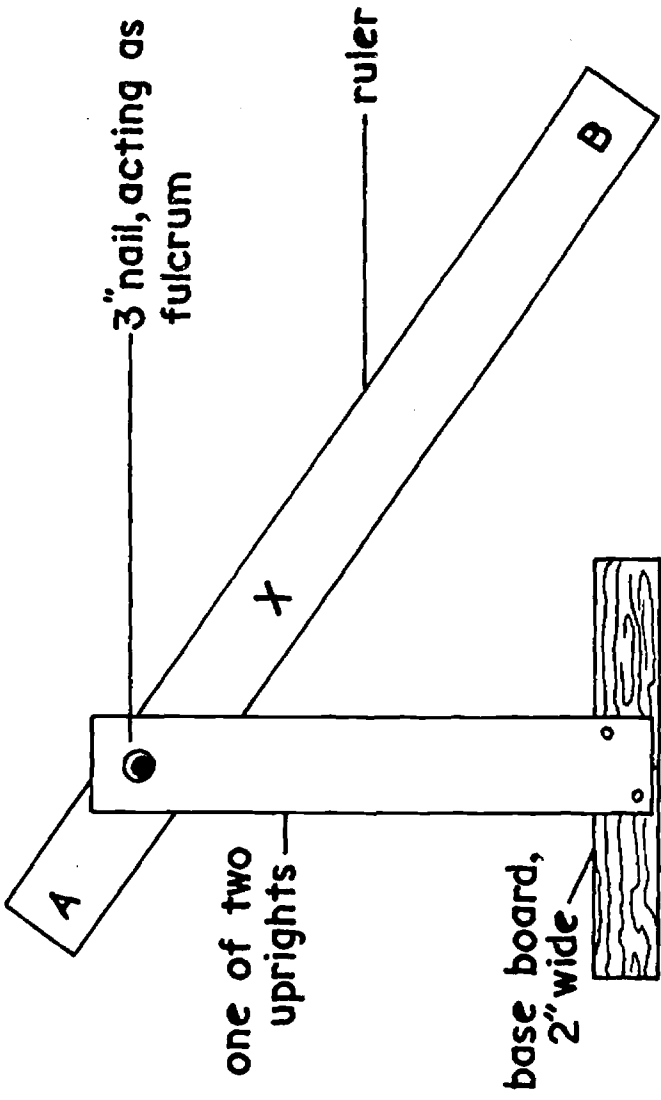

Device for demonstrating the three orders of levers.

through a foot ruler at the 2" mark. Insert the nail through the uprights and the ruler. See diagram.

If a load, e.g. a weight on a looped thread, is placed at A, and the ruler is pushed down at B, it is acting as a first class lever. If the load is placed at X, and the ruler is lifted at B, it is a second order lever. If the load is at B, and an effort is exerted upwards at X, the result is a third order lever.

21. Working models of meshing gear wheels are needed to show: conversion of a clockwise motion to an anti-clockwise one; conversion of a vertical rotation to a horizontal one; and change of speed of rotation. The latter two can be demonstrated on an egg-beater (G.S. Item 104482) or on a hand drill. Clockwise to anti-clockwise motion can be shown by using three bottle tops: carefully straighten the tops out, then nail them to a board through their exact centres in such a way that their teeth mesh. Work the holes loose, so that the bottle tops rotate easily.

Gears are readily available in old clocks, and in various kinds of educational toy. The Lincoln "Looky" telephone is very good: as a child dials, various sized cogs can be seen, through the clear plastic case, to make the bell tinkle.

22. A flannel sports pennant rolled up demonstrates that a screw may be regarded as an inclined plane wound around a central axis: the edge of the pennant represents the inclined plane. A better model is made as follows: cut out a piece of flannel in the shape of a right angled triangle, making the perpendicular about 5" long. Make the hypotenuse edge a distinct colour with Texta-Color. Fasten the perpendicular side to a pencil with sticky tape. Wind the flannel onto the pencil and the hypotenuse edge, which started out as a simple inclined plane, becomes the bearing surface of a screw. Stand a large screw beside the model and note the similarity.
23. The diagram opposite shows a working model of a jack screw. The head of the bolt is set into a wooden base. The load is placed on a lid or tray glued with Araldite or other epoxy resin to a length of galvanised water-pipe. When the spanner turns the nut, the load is lifted.
24. A glass prism, for showing the refraction of white light into the colours of the spectrum, may be purchased from Government Stores Item 120613. Stand outside the classroom with a hand mirror reflecting sunlight through the prism held with base uppermost: a brilliant spectrum can thus be thrown onto an interior wall of the classroom.

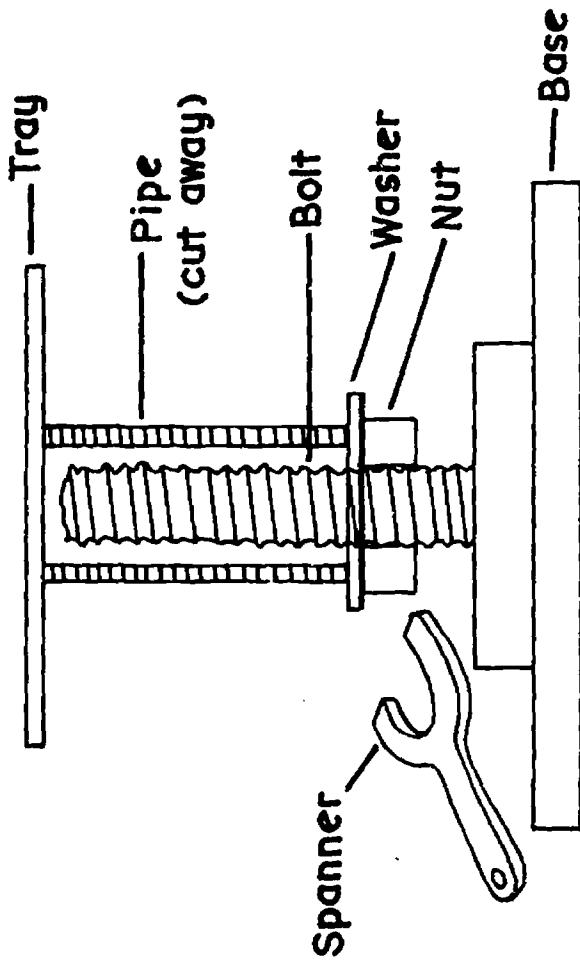

Model Jack Screw

-39-

25. For the Sixth Grade collection of minerals and rocks, start with all the specimens mentioned in the Fifth Grade list, and add and classify as many others as possible. In particular, fossil-bearing sedimentary rocks should be featured.

\* \* \*

Publication of the Centre for Advancement of Teaching,  
Macquarie University