

DOCUMENT RESUME

ED 046 776

24

SE 010 737

TITLE Unified Modern Mathematics, Course 3, Teachers  
Commentary.

INSTITUTION Secondary School Mathematics Curriculum Improvement  
Study, New York, N.Y.

SPONS AGENCY Columbia Univ., New York, N.Y. Teachers College.;  
Office of Education (DHEW), Washington, D.C. Bureau  
of Research.

BUREAU NO BR-7-0711

PUB DATE [70]

CONTRACT OEC-1-7-070711-4420

NOTE 351p.

EDRS PRICE MF-\$0.65 HC Not Available from EDRS.

DESCRIPTORS Course Descriptions, \*Curriculum Guides,  
\*Instruction, \*Instructional Materials, Mathematics,  
\*Secondary School Mathematics, \*Teaching Guides

ABSTRACT

This commentary is to be used with "Unified Modern Mathematics, Course III." Statements of specific purposes and goals of each section of every chapter of Course III are included in the "Commentary." Also included are suggestions for teaching concepts presented in each section; time estimates for each section; suggested instructional aids for presenting various concepts; references for further study; and chapter examinations which constitute a comprehensive test for each chapter. [Not available in hardcopy due to marginal legibility of original document.] (FL)

ED0 46776

BR 7-0711  
PA-24  
SE

*Secondary School Mathematics  
Curriculum Improvement Study*

**UNIFIED MODERN  
MATHEMATICS**

U.S. DEPARTMENT OF HEALTH, EDUCATION  
& WELFARE  
OFFICE OF EDUCATION  
THIS DOCUMENT HAS BEEN REPRODUCED  
EXACTLY AS RECEIVED FROM THE PERSON OR  
ORGANIZATION ORIGINATING IT. POINTS OF  
VIEW OR OPINIONS STATED DO NOT NECES-  
SARILY REPRESENT OFFICIAL OFFICE OF EDU-  
CATION POSITION OR POLICY.

**COURSE III**

**TEACHERS' COMMENTARY**

ERIC COLLEGE OF COLUMBIA UNIVERSITY



010 737

ERIC  
Full Text Provided by ERIC

TEACHERS COMMENTARY

FOR

COURSE III

OF

UNIFIED MODERN MATHEMATICS



SECONDARY SCHOOL MATHEMATICS

CURRICULUM IMPROVEMENT STUDY

Secondary School Mathematics Curriculum Improvement Study

Course III - Teachers Commentary

HOW TO USE THIS COMMENTARY

1. Purposes. As in the first two courses, the teacher must be aware of the important topics and concepts that run through the main body of the previous courses to create a unified approach to mathematics. Students will learn to view mathematics as a unified subject only if basic relations and properties are continuously used and emphasized. The concepts learned in Course I and Course II are to be used to an advantage in the presentation of Course III. Teachers presenting Course III must be familiar with the content and concepts emphasized in the previous courses.

At the start of each chapter, the overall purposes and aims for the unit are stated. The commentary for every section within the chapter will start with a statement of specific purposes.

2. Sections. There are two basic types of sections within each chapter. One type presents concepts; the second type consists of exercises. The sections have been ordered so that a section (or sometimes two sections) of exposition is followed by a section of related exercises. Within

various sections, the teacher will find: possible motivational devices; a variety of approaches; notations relative to difficult exercises; suggestions for placement of exercises as class work; homework or self-study; hints regarding difficulties that may occur; new vocabulary underscored; and some abstract background for the teacher.

3. Time Estimates. In terms of days, a time estimate will be found at the beginning of each chapter commentary. This is the estimate for the chapter; it is based upon individual time estimates for sections within the chapter.

Time estimates are given only to those sections containing some form of exposition. It is assumed that each exercise section is to be grouped with the concept section immediately preceding it relative to time estimations.

4. Exercises. Certain exercises have proved to be more successful when discussed within the actual lesson rather than assigned as homework. Suggestions regarding the placement of exercises appear at various points within the commentary.

The teacher need not hold rigidly to the exercises listed. He is free to choose, add or alter any exercises whatsoever. In instances stressing drill, the teacher may wish to select or limit exercises depending upon the particular skills of his class and/or individual students. Difficult

problems have been starred and may be considered as optional. However, these problems are the most rewarding as well as the most challenging, and the teacher should discuss some of these in the classroom and/or assign them to the better students as homework. In all instances, the teacher should study the exercises before assigning them, carefully noting the concepts involved and approximating the time required for those exercises chosen. To insure that the teachers' evaluation of time for an assignment is as accurate as possible, the teachers should occasionally ask students to time homework assignments, allowing him to compare the true mean time with his judgment.

In Chapter 5 (combinatorics) additional problems have been included, to be used at the discretion of the teacher.

5. Proofs. The proofs presented in the commentary and the text are not to be accepted as the only possible, logical proof. The teacher should expose the students to other approaches, and encourage the students to develop their own proofs. Student approaches, very often, are more direct, less involved, yet complete mathematical solutions to problems.

In Chapter 9 on Informal Geometry, some complete mathematical proofs should be presented by the teacher with the use of the observations (axioms) and conclusions (theorems) derived from the observations. In addition, some

of the students should be encouraged to develop and present formal proofs on theorems not done in class. Time may not permit to do so with all the theorems, but some of them yield to relatively short yet complete proofs which can be done or at least followed by most pupils.

6. Summary and Review Exercises. At the end of each chapter, the teacher will find a summary of the main concepts studied, followed by a series of related review exercises.

The teacher may wish to assign the reading of the summary and the completion of the review exercise as:

- (a) homework to be reviewed in class the following day,
- (b) self-study with time allowed the following day for student questions.,
- (c) classwork or
- (d) test items.

7. Tests. At the end of each chapter commentary, the teacher will find a **series** of suggested test items. The teacher should again feel free to choose, add, or alter any of these problems in constructing a test for his own class. An additional source of test items, when altered, would be the review exercises appearing at the end of each chapter in the text.

8. The Pitfalls To Avoid. To guarantee that the suggested

curriculum be essentially covered within the time span of one school year, the teacher should be flexible enough to:

- a. Drop specific topics that prove to be overly difficult, with the idea of coming back to this material at a later date;
- b. Judge whether certain topics will be seen again, as in a spiral approach, and then realize that complete mastery need not always be obtained with the introduction to the material;
- c. Select exercises as needed rather than assign all of the problems indicated;
- d. Assign additional exercises and/or construct new worksheets as the need arises with each specific class;
- e. Provide occasional review sheets throughout the term to supplement spiral approach;
- f. Have copies of Course I and II readily available for reference;
- g. Teach the "spirit" rather than the "letter" of the program.



Teachers Commentary of Unified Modern Mathematics Course

III is an expansion of the original commentary written by the authors of the text. It was revised by the following pilot teachers in the SSMCIS Project:

Franklin B. Armour, Teaneck, New Jersey

Samuel Backer, Elmont, New York

Annabelle Cohen, Teaneck, New Jersey

Alexander Imre, Elmont, New York

Edward Keenan, Elmont, New York

Christine McGoey, Leonia, New Jersey

Mary P. Renda, Teaneck, New Jersey

David Swaim, Leonia, New Jersey

A practical list of suggestions and a reasonable estimation of time allotments for the whole of this commentary is included based upon the experiences of the above pilot teachers.

Time Estimate - Course III

Chapters	Teaching Days	Test	Total
1	10 - 12	1	11 - 13
2	12 - 14	1	13 - 15
3	12 - 14	1	13 - 15
4	14 - 18	1	15 - 19
5	19	2	21
6	12 - 14	1	13 - 15
7	16 - 20	1	17 - 21
8	16 - 20	1	17 - 21
9	9 - 12	1	10 - 13

## Chapter 1

### INTRODUCTION TO MATRICES

Time Estimate: 10 - 13 days

This Chapter has two main objectives. The first is to show that matrices are a natural and neat way to display data in some situations. The situations chosen for this purpose relate to baseball, mileage charts, economics (the case of the builder of homes), coding and decoding secret messages, solving systems of two linear equations in two unknowns, bus route connections between towns, geometric transformations, and transition of states. The list is impressive, but by no means exhausts the actual number and only suggests the great variety of possibilities.

The use of matrices as a means of simplifying the presentation of data is unquestionably valuable. But if that were its only value it would not have become a subject of mathematical inquiry. The situation may be compared with the stage in man's history when he knew what numbers were, using them to tell how many there were in a set of objects, but not yet realizing that they could be added, subtracted, multiplied, and divided. Thus the second objective in this chapter is to show that operations on matrices are a natural outcome, as are operations on numbers. This is easily done for adding matrices, and multiplying a scalar and a matrix. It is more difficult for multiplication of matrices. But all operations with matrices can be developed naturally as the result of (1) asking the right questions,

(2) allowing students to answer them, and finally, (3) seeing how students' answers may be regarded as some operation with matrices. It is hoped that when done this way, students will see how natural, though strange, the three operations on matrices are.

In the course of learning these operations, a number of mathematical questions will arise. For example, the commutativity of addition or multiplication of matrices. It is not the aim of this chapter to give final answers to such questions, nor should you discourage students from asking them, or even discussing them. It is the aim of this chapter to stir and whet the students' curiosity concerning the properties of the operations. It would be unfortunate to engage in formal discussion about these properties in this chapter while many students are still trying to understand the operations themselves. We prefer to expose students to the formal considerations in Chapter 2. Meanwhile there will surely be some students who will anticipate the formal results. They should be encouraged individually and privately. They should not be allowed to "spoil" it for others by presenting their discoveries to an audience not ready to receive them.

### References

Davis, P. J. Mathematics of Matrices. New York: Interscience Publishers Inc., 1963.

Eves, Howard. Elementary Matrix Theory. Boston: Allyn and Bacon, Inc., 1966.

Kemeny, Snell, Thompson. Introduction to Finite Mathematics. Englewood Cliffs, N. J.: Prentice-Hall Inc., 1957.

Matthews, G. Contemporary School Mathematics Matrices 1 and 2.  
London: Edward Arnold, 1964.

School Mathematics Study Group. Introduction to Matrix Algebra.  
Pasadena: A. C. Vroman Inc., 1965.

### 1.1 What is a Matrix (Time for 1.1 and 1.2 = 1 to $1\frac{1}{2}$ days)

Matrices were used to tabulate data in rectangular arrays long before mathematicians became interested in them. In this sense, a railroad timetable and a stock market report are matrices. In 1845 Arthur Cayley (1821-1895) observed in his treatise on linear transformations that every linear transformation could be associated with a rectangular array, and called these arrays matrices. Matrices turned out to be a convenient tool in discussing linear transformations and soon thereafter mathematicians found that other situations also submitted to a matrix approach. The advent of electronic computers made it possible to use matrices in disciplines that had been considered unrelated to mathematics, and this in turn, further encouraged mathematicians to study matrices energetically.

In this section the student takes a first step in the direction of appreciating the values of matrices hinted above. That step is a small one, concerned with situations with which he is familiar and in which he is probably interested. The student is also expected to familiarize himself with terms associated with matrices: row, column, first row, first column, and  $a_{ij}$ , the entry in the  $i$ th row,  $j$ th column.

## 1.2 Exercise Solutions

1. a.  $10 \times 5$    b. 4.7; 61.6   c.  $\{0, 52.6, 49.8, 20.4, 1.4\}$ ,  
 $\{a_{ij}; i = j, j \leq 5\} = \{a_{ii}; i \leq 5\}$ .  
d. The greatest entry in the first row is 49.0. The greatest part of professional and technicians have college training.  
e. The greatest entry in the first column is 5.1. There are more people with no schooling among farm laborers and foremen than among any other group.  
f. The greatest number in the fifth row 61.6; the least is .2. Among sales people the greatest number are high school trained, the least have no schooling.  
g. The greatest number in the fifth column is 28.0; the least is 0. The greatest number of graduate students are professionals and technicians; the least are farm laborers and foremen.
2. b. The stock market is a matrix. In the New York Times version there are 8 columns: yearly high, yearly low, numbers of stocks sold, first bid of the day, high bid, low, last, net change. The number of rows is equal to the names of the stocks. Sometimes a dividend (as a ninth column) appears.
3. a.  $6 \times 5$    b.  $a_{1,1} = 29,028$ ,  $a_{2,1} = 11,500,000$ ,  $a_{4,5} = -27.4$   
c.  $\{11,500,000, 19,340, -436, 136.0, -11.4\}$ .  
d.  $\{16,900,000, 19,340, -228, 120.0, -67.0\}$ .

- e. {11,500,000, 20,320, -131, 122.0, -8.0}.
- f. {29,028, -436, 134.0, -27.4}.
- g. {11,500,000, 22,834, -39}.

1.3 Using Matrices to Describe Complex Situations (Time for  
1.3 and 1.4 = 1 to  $1\frac{1}{2}$  days)

In this section we show how matrices can simplify the presentation of a set of rules used in a game to determine the amounts won or lost by each of two players. To keep the illustration simple, we choose a game in which only two possible strategies are available to each player (heads or tails). If you wish to use an illustration in which more than two strategies are available to the players, you might use the game in which each of two players presents 1, 2, or 3 fingers, at a signal, with a set of rules that determine the amount won or lost by each player.

More amazing is the second example which concerns bus routes between town. This is a specific case of planar graphs used in geometry (see Graphs and Their Uses by Oystein Ore, The L. W. Singer Co. 1963) and in representing communications networks by matrices (see Kemeny, Snell, Thompson: Introduction to Finite Mathematics, Prentice Hall, pages 315-320).

The section ends with a discussion of coefficient matrices, associated with systems of two linear equations in two variables. The coefficient matrices are to be an important tool in this and the next chapter, in solving a system of linear equations.

They are also an introduction to transformation matrices.

Note to teacher: In Exercises 1.4, problem 3, tell students to follow the Example 2 (Figure 1.5) in the text, to avoid confusion.

### 1.4 Exercise Solutions

1.

		loser		
		A	B	C
Winner	A	0	40	30
	B	35	0	25
	C	38	32	0

$a_{ij} \neq a_{ji}$  except when  $i = j$  (that is,  $a_{ii} = 0$ )

2.

		B					
		1	2	3	4	5	6
A	1	2	-3	4	-5	6	-7
	2	-3	4	-5	6	-7	8
	3	4	-5	6	-7	8	-9
	4	-5	6	-7	8	-9	10
	5	6	-7	8	-9	10	-11
	6	-7	8	-9	10	-11	12

3.

a.

		A	B	C	D
A	0	1	1	0	
B	1	0	1	1	
C	1	1	0	0	
D	0	1	0	0	

b.

		A	B	C	D
A	0	1	1	0	
B	1	0	1	1	
C	1	1	0	1	
D	0	1	1	0	



c.

	A	B	C	D
A	0	1	0	0
B	1	0	2	0
C	0	2	0	0
D	0	0	0	0

d.

	A	B	C	D
A	0	0	1	0
B	0	0	0	1
C	1	0	0	1
D	0	1	1	0

e.

	A	B	C	D
A	0	0	1	0
B	0	0	1	1
C	1	1	0	0
D	0	1	0	0

4. a.  $\begin{bmatrix} 3 & 5 \\ 4 & -2 \end{bmatrix}, \begin{bmatrix} 3 & 5 & 8 \\ 4 & -2 & 0 \end{bmatrix}$  b.  $\begin{bmatrix} 3 & 2 & -1 \\ 2 & -3 & 1 \end{bmatrix}, \begin{bmatrix} 3 & 2 & -1 & 3 \\ 2 & -3 & 1 & 5 \end{bmatrix}$

c.  $\begin{bmatrix} 2 & 3 \\ 1 & 2 \\ 1 & -4 \end{bmatrix}, \begin{bmatrix} 2 & 3 & 4 \\ 1 & 2 & 8 \\ 1 & -4 & -4 \end{bmatrix}$  d.  $\begin{bmatrix} 1 & 1 & 1 \\ 1 & 1 & 0 \\ 0 & 1 & 1 \end{bmatrix}, \begin{bmatrix} 1 & 1 & 1 & 3 \\ 1 & 1 & 0 & 2 \\ 0 & 1 & 1 & 1 \end{bmatrix}$

e.  $\begin{bmatrix} 2 & -1 \\ 2 & -1 & 5 \end{bmatrix}$  f.  $\begin{bmatrix} 2 & -4 & 1 \\ 2 & -4 & 1 & 8 \end{bmatrix}$

1.5 Operations on Matrices (Time for 1.5 and 1.6 = 2 to  $2\frac{1}{2}$  days)

This section presents three operations.

- (1) Addition of two matrices having the same dimensions.
- (2) Multiplying a scalar and a matrix (the component parts of a matrix are scalars), and
- (3) Multiplying two matrices.

All of these operations emerge from a consideration of a single situation; the case of a builder of homes, building two models, in three towns, for two years. Data are presented in matrix form. Then questions are asked which relate to the situation. Each question is designed to elicit an answer which can be formulated as an operation on the matrices. We suggest that you give these questions a prominent role in your presentation, repeating them if necessary, to clarify their meaning. It will be more difficult to describe multiplication with two matrices. To help your students understand multiplication, write their answers at the boards, as is done in the text following Figure 1-10 ending with Figure 1-11. It is possible that, even with this, all students will not see the pattern in the multiplication. Figure 1-12 may help these students. When the operation is understood, it may be remembered as multiply "row by column" - not an accurate description - only a mnemonic device.

Multiplying matrices having large dimensions, say  $20 \times 25$  and  $25 \times 30$ , is a cumbersome process. (In management science studies one may meet matrices with dimensions  $100 \times 300$ .) Multiplying matrices does arise in economics and sciences. It is not difficult to program a computer to carry out these multiplications no matter what the dimensions. Largely for this reason matrices have become an important tool in scientific and management studies.

### 1.6 Exercise Solutions

1. a. Dimensions of D, E, F, G are respectively 2 x 3, 2 x 3, 3 x 2, 2 x 1.

b. 
$$D + E = \begin{bmatrix} 5 & 3 & 3 \\ 7 & 5 & 2 \end{bmatrix}$$

- c. No. Addition is defined only for two matrices having the same dimensions.

d. 
$$D \cdot F = \begin{bmatrix} 3 & 2 & 1 \\ 4 & 0 & 2 \end{bmatrix} \cdot \begin{bmatrix} 4 & 5 \\ 5 & 6 \\ 5 & 7 \end{bmatrix} = \begin{bmatrix} 27 & 34 \\ 26 & 34 \end{bmatrix} .$$

- e. No. D does not have as many columns as E has rows.

- f. E · F is the number of doors and number of windows used in the 1968 program in P and Q. F · G is the cost of doors and windows used for each model.

- g. (E · F) · G means the cost of doors and windows used in the 1968 program. E · (F · G) means the same thing.

$$(E \cdot F) \cdot G = E \cdot (F \cdot G) = \begin{bmatrix} 295 \\ 455 \end{bmatrix}$$

h. 
$$3D = \begin{bmatrix} 9 & 6 & 3 \\ 12 & 0 & 6 \end{bmatrix}$$

2. a. 
$$\begin{bmatrix} 0 & 4 \\ 6 & 2 \end{bmatrix}$$

- b. These matrices cannot be added. Their dimensions differ.

c. 
$$\begin{bmatrix} 0 & 1 & 3 \\ 4 & 6 & 9 \end{bmatrix}$$

- d. See (b).

e. 
$$\begin{bmatrix} 0 & 0 \\ 0 & 0 \\ 0 & 0 \end{bmatrix}$$

f. 
$$\begin{bmatrix} a & b \\ c & d \end{bmatrix}$$

3. a.  $\begin{bmatrix} 0 \\ 0 \end{bmatrix}$

b.  $\begin{bmatrix} 6 & 6 & 9 \\ 18 & 18 & 27 \end{bmatrix}$

c. Not possible. The first matrix does not have as many columns as the second matrix has rows.

d.  $\begin{bmatrix} 10 & 20 \end{bmatrix}$

e. Not possible. See (c).

f.  $\begin{bmatrix} a & b \\ c & d \end{bmatrix}$

g.  $\begin{bmatrix} 1 & 0 \\ 0 & 1 \end{bmatrix}$

h.  $\begin{bmatrix} a^2 & 0 \\ 0 & a^2 \end{bmatrix}$

i. Not possible. The first matrix has more columns than the second matrix has rows.

j.  $\begin{bmatrix} a^2 + bc & ab + bd \\ ac + cd & bc + d^2 \end{bmatrix}$

k.  $\begin{bmatrix} 0 & 0 \\ 0 & 0 \end{bmatrix}$

l.  $\begin{bmatrix} c & d \\ a & b \end{bmatrix}$

4. a.  $\begin{bmatrix} 12 & 8 \\ -4 & 0 \end{bmatrix}$

b.  $\begin{bmatrix} 2 \\ -\frac{1}{2} \\ \frac{3}{2} \end{bmatrix}$

c.  $\begin{bmatrix} 0 & 0 & 0 \\ 0 & 0 & 0 \end{bmatrix}$

d.  $\begin{bmatrix} 12 & 13 \\ -1 & 20 \end{bmatrix}$

e.  $\begin{bmatrix} 3 & 2 \\ 2 & 3 \end{bmatrix}$

f.  $a \left( \begin{bmatrix} a & b \\ c & d \end{bmatrix} \cdot \begin{bmatrix} x \\ y \end{bmatrix} \right) = a \left( \begin{bmatrix} a & b \\ c & d \end{bmatrix} \right) \begin{bmatrix} x \\ y \end{bmatrix} = \begin{bmatrix} a^2x + aby \\ acx + ady \end{bmatrix}$

g. The addition is not possible.

h. The second multiplication is not possible.

i.  $\begin{bmatrix} x + 2z \\ x + 2y + 3z \\ -x + 2y \end{bmatrix}$

5.  $\begin{bmatrix} 1 & 2 \\ 2 & 6 \end{bmatrix} \cdot \begin{bmatrix} 4 & 3 \\ 3 & 2 \end{bmatrix} = \begin{bmatrix} 10 & 7 \\ 26 & 18 \end{bmatrix}$

$\begin{bmatrix} 4 & 3 \\ 3 & 2 \end{bmatrix} \cdot \begin{bmatrix} 1 & 2 \\ 2 & 6 \end{bmatrix} = \begin{bmatrix} 10 & 26 \\ 7 & 18 \end{bmatrix} \neq \begin{bmatrix} 10 & 7 \\ 26 & 18 \end{bmatrix}$

6.  $\begin{bmatrix} 3 & 5 \\ 1 & 2 \end{bmatrix} \cdot \begin{bmatrix} 3 & -5 \\ -1 & 2 \end{bmatrix} = \begin{bmatrix} 4 & -5 \\ 1 & -1 \end{bmatrix}$  and  $\begin{bmatrix} 3 & -5 \\ -1 & 2 \end{bmatrix} \cdot \begin{bmatrix} 3 & 5 \\ 1 & 2 \end{bmatrix} = \begin{bmatrix} 4 & 5 \\ -1 & -1 \end{bmatrix}$

Therefore the products are not the same.

7. a.  $\begin{bmatrix} 3 & 2 \\ 1 & 4 \end{bmatrix}$       b.  $\begin{bmatrix} 2 & -1 \\ -2 & 4 \end{bmatrix}$       c.  $\begin{bmatrix} a & b \\ c & d \end{bmatrix}$

8. Same answers as those in Exercise 7.

1.7 Matrices and Coded Messages (Time for 1.7 and 1.8 = 1 to  $1\frac{1}{2}$  days)

This section should be fun for both student and teacher. Coding and decoding interest many youngsters, as well as adults. Built into this coding device "lurk" two mathematical problems. One, is the question of invertibility. Suppose, for instance, a coding matrix is  $\begin{bmatrix} 3 & 2 \\ 6 & 4 \end{bmatrix}$ . It has no multiplicative inverse, hence no decoding matrix exists. (See Chapter III for explanation of why it has no multiplicative inverse). The other is the question of commutativity. If the coding matrix is a "right" multiplier (some books call it a "post" multiplier), then the decoding has to be a "right" multiplier also, in order to be effective. A "left" (pre-multiplier) multiplier does not produce the original message! Here is a dramatic demonstration that suggests that multiplying two matrices is not commutative.

The coding and decoding matrices used in the text are also used in exercises 3-4 of Section 1.8 to solve pairs of linear equations in two unknowns. Note, however, that these equations are restricted to those whose coefficient matrix is either the

coding or decoding matrix. This is done with "malice aforethought" in order to motivate the students, stirring up some curiosity, without supplying mathematical explanations. We hope, as a result, that many questions will occur to the student, which being noted, are tabled to Chapters 2 and 3. This is done so that students may explore the questions by themselves and thus give them an opportunity for mathematically creative activities.

Very Important Note to Teacher: It is necessary for the teacher to point out that the form of the decoding matrix in comparison with that of the coding matrix in this section, is not the general relationship between a matrix and its multiplicative inverse. It is very probable that students will jump to the conclusion that a coding matrix of the form  $\begin{bmatrix} a & b \\ c & d \end{bmatrix}$  has a corresponding decoding matrix of the form  $\begin{bmatrix} a & -b \\ -c & d \end{bmatrix}$  or  $\begin{bmatrix} d & -b \\ -c & a \end{bmatrix}$ , which is false. To convince them, give them the coding matrix  $\begin{bmatrix} -2 & -3 \\ 1 & 2 \end{bmatrix}$  and ask them to try and find the decoding matrix, which is  $\begin{bmatrix} -2 & -3 \\ 1 & 2 \end{bmatrix}$ . Or try the coding matrix  $\begin{bmatrix} 4 & 2 \\ 3 & 1 \end{bmatrix}$  whose decoding matrix is  $\begin{bmatrix} -\frac{1}{2} & 1 \\ \frac{3}{2} & -2 \end{bmatrix}$ . (See Chapter III for explanation of how to find the decoding or multiplicative inverse matrix.) Also stress that if the coding matrix is a right multiplier, so must the decoding matrix be. To convince them, have them try to decode a message by multiplying on the left with the decoding

matrix.

### 1.8 Exercise Solutions

1. a. COME HOME substitution, 3 15 13 5                      8 15 13 5

$$\rightarrow \begin{bmatrix} 3 & 15 \\ 13 & 5 \end{bmatrix}, \begin{bmatrix} 8 & 15 \\ 13 & 5 \end{bmatrix} \quad \begin{bmatrix} 3 & 15 \\ 13 & 5 \end{bmatrix} \cdot \begin{bmatrix} 2 & 3 \\ 1 & 2 \end{bmatrix}, \begin{bmatrix} 8 & 15 \\ 13 & 5 \end{bmatrix} \cdot \begin{bmatrix} 2 & 3 \\ 1 & 2 \end{bmatrix}$$

$$\rightarrow \begin{bmatrix} 21 & 39 \\ 31 & 49 \end{bmatrix}, \begin{bmatrix} 31 & 54 \\ 31 & 49 \end{bmatrix} \rightarrow 21 \ 39 \ 31 \ 49 \ 31 \ 54 \ 31 \ 49$$

b. WHER EARE YOUX  $\rightarrow \begin{bmatrix} 23 & 8 \\ 5 & 18 \end{bmatrix}, \begin{bmatrix} 5 & 1 \\ 18 & 5 \end{bmatrix}, \begin{bmatrix} 25 & 15 \\ 21 & 24 \end{bmatrix}$

$$\rightarrow \begin{bmatrix} 54 & 85 \\ 28 & 51 \end{bmatrix}, \begin{bmatrix} 11 & 17 \\ 41 & 64 \end{bmatrix}, \begin{bmatrix} 65 & 105 \\ 66 & 111 \end{bmatrix}$$

$$\rightarrow 54 \ 85 \ 28 \ 51 \ 11 \ 17 \ 41 \ 64 \ 65 \ 105 \ 66 \ 111$$

2. a. 58 97 27 53 25 49 27 53  $\rightarrow \begin{bmatrix} 58 & 97 \\ 27 & 53 \end{bmatrix}, \begin{bmatrix} 25 & 49 \\ 27 & 53 \end{bmatrix}$

$$\rightarrow \begin{bmatrix} 58 & 97 \\ 27 & 53 \end{bmatrix} \cdot \begin{bmatrix} 2 & -3 \\ -1 & 2 \end{bmatrix}, \begin{bmatrix} 25 & 49 \\ 27 & 53 \end{bmatrix} \cdot \begin{bmatrix} 2 & -3 \\ -1 & 2 \end{bmatrix} \rightarrow \begin{bmatrix} 19 & 20 \\ 1 & 25 \end{bmatrix}, \begin{bmatrix} 1 & 23 \\ 1 & 25 \end{bmatrix}$$

$\rightarrow$  STAY AWAY

b.  $\begin{bmatrix} 30 & 51 \\ 52 & 89 \end{bmatrix}, \begin{bmatrix} 35 & 65 \\ 51 & 87 \end{bmatrix} \quad \begin{bmatrix} 9 & 12 \\ 15 & 22 \end{bmatrix}, \begin{bmatrix} 5 & 25 \\ 15 & 21 \end{bmatrix}$

I LOVE YOU

3. a.  $\begin{bmatrix} 2 & -3 \\ -1 & 2 \end{bmatrix} \cdot \begin{bmatrix} 5 \\ 4 \end{bmatrix} = \begin{bmatrix} -2 \\ 3 \end{bmatrix}$

$(x, y) = (-2, 3)$

Check:  $2(-2) + 3(3) = 5$   
 $(-2) + 2(3) = 4$

b.  $\begin{bmatrix} 2 & -3 \\ -1 & 2 \end{bmatrix} \cdot \begin{bmatrix} -5 \\ -2 \end{bmatrix} = \begin{bmatrix} -4 \\ 1 \end{bmatrix}$

$(x, y) = (-4, 1)$

Check:  $2(-4) + 3(1) = -5$   
 $(-4) + 2(1) = -2$

$$c. \begin{bmatrix} 2 & -3 \\ -1 & 2 \end{bmatrix} \cdot \begin{bmatrix} 12 \\ 6 \end{bmatrix} = \begin{bmatrix} 6 \\ 0 \end{bmatrix}$$

$$(x,y) = (6,0)$$

Check:  $2(6) + 3(0) = 12$   
 $6 + 2(0) = 6$

$$d. \begin{bmatrix} 2 & -3 \\ -1 & 2 \end{bmatrix} \cdot \begin{bmatrix} 0 \\ 5 \end{bmatrix} = \begin{bmatrix} -15 \\ 10 \end{bmatrix}$$

$$(x,y) = (-15,10)$$

Check:  $2(-15) + 3(10) = 0$   
 $(-15) + 2(10) = 5$

$$e. \begin{bmatrix} 2 & -3 \\ -1 & 2 \end{bmatrix} \cdot \begin{bmatrix} 0 \\ 0 \end{bmatrix} = \begin{bmatrix} 0 \\ 0 \end{bmatrix}$$

$$(x,y) = (0,0)$$

Check:  $2(0) + 3(0) = 0$   
 $0 + 2(0) = 0$

4. Use the coding matrix.

$$a. \begin{bmatrix} 2 & 3 \\ 1 & 2 \end{bmatrix} \cdot \begin{bmatrix} 5 \\ -2 \end{bmatrix} = \begin{bmatrix} 4 \\ 1 \end{bmatrix}$$

$$(x,y) = (4,1)$$

Check:  $2(4) - 3(1) = 5$   
 $-(4) + 2(1) = -2$

$$b. \begin{bmatrix} 2 & 3 \\ 1 & 2 \end{bmatrix} \cdot \begin{bmatrix} 7 \\ -2 \end{bmatrix} = \begin{bmatrix} 8 \\ 3 \end{bmatrix}$$

$$(x,y) = (8,3)$$

Check:  $2(8) - 3(3) = 7$   
 $-(8) + 2(3) = -2$

$$c. \begin{bmatrix} 2 & 3 \\ 1 & 2 \end{bmatrix} \cdot \begin{bmatrix} 4 \\ -2 \end{bmatrix} = \begin{bmatrix} 2 \\ 0 \end{bmatrix}$$

$$(x,y) = (2,0)$$

Check:  $2(2) - 3(0) = 4$   
 $-(2) + 2(0) = -2$

5. Many possible answers. For example, see Exercise 1a where "M" and "H" both become "31." (It is hoped that this exercise induces the contention that multiplication of matrices is not commutative.)

6. No. See Exercise 5, or try it!



1.9 Matrices and Transformations (Time for 1.9 and 1.10 = 2 to  $2\frac{1}{2}$  days)

This is a good opportunity to review transformations, and, at the same time, extend students' abilities to study transformations through the use of matrices as tools. The matrix of a transformation is derived in exactly the same manner as the coefficient matrix of a set of linear equations; namely, by detaching coefficients of variables, without disturbing their relative locations. We have restricted ourselves in this section to transformations with coordinate rules, for which the origin is a fixed point. This includes reflections in the x-axis, y-axis,  $l$ , (the line with equation  $y = x$ ), two rotations about the origin, dilations about 0, but not translations nor glide reflections. To include the latter exceptions we would have to use  $2 \times 3$  (or  $3 \times 3$ ) matrices, and this would mar the simplicity of a first approach to this topic. Consider for instance, the composition of the halfturn about 0 with matrix  $\begin{bmatrix} -1 & 0 \\ 0 & -1 \end{bmatrix}$  and the translation with rule  $(x, y) \longrightarrow (x + a, y + b)$ , or what comes to the same thing, the matrix  $\begin{bmatrix} 1 & 0 & a \\ 0 & 1 & b \end{bmatrix}$ . The composition requires a multiplication of matrices. We can multiply  $\begin{bmatrix} -1 & 0 \\ 0 & -1 \end{bmatrix} \cdot \begin{bmatrix} 1 & 0 & a \\ 0 & 1 & b \end{bmatrix}$  but not  $\begin{bmatrix} 1 & 0 & a \\ 0 & 1 & b \end{bmatrix} \cdot \begin{bmatrix} -1 & 0 \\ 0 & -1 \end{bmatrix}$ . This introduces a problem for which students are not ready. It can be solved by using homogeneous coordinates in a projective plane. This results in

$$\begin{bmatrix} -1 & 0 & 0 \\ 0 & -1 & 0 \\ 0 & 0 & 1 \end{bmatrix} \text{ and } \begin{bmatrix} 1 & 0 & a \\ 0 & 1 & b \\ 0 & 0 & 1 \end{bmatrix}$$

Note the natural way in which the question of associativity arises in connection with the effect of a composite transformation on a point. For this we need a product of three matrices, and the question taken up in the text leads to an interpretation of the product of two transformation matrices.

We have introduced a shear in a plane in this section since, like the other plane transformations, it too has a simple  $2 \times 2$  matrix.

A shear is a stretching, but not an equal stretching. An example of a shear is the mapping  $(x,y) \longrightarrow (ax + by, cy)$ . The concept of a shear is useful in physics, especially fluid mechanics. For a reference see "Geometric Transformations, Volume 1" by Modenov and Parkhomenko, Academic Press.

But simplicity of matrices does not necessarily make for simplicity of transformation. For examples, see Exercise 4(a) and Exercise 5 in the section that follows.

Do not expect your students to give a full account of the transformations with matrix  $\begin{bmatrix} 2 & 3 \\ 1 & 2 \end{bmatrix}$  (the coding matrix). You should be content with a description which reconverts the matrix to the coordinate rule. So, for  $\begin{bmatrix} 2 & 3 \\ 1 & 2 \end{bmatrix}$  expect " $(x,y) \longrightarrow (2x + 3y, x + 2y)$ ".

We have not considered what interpretations to give the sum of two matrices associated with transformations. Actually,

the answer is simple.

When a matrix has the form  $\begin{bmatrix} a \\ b \end{bmatrix}$  it can be interpreted as being associated with the translation that maps (0,0) onto (a,b), and  $\begin{bmatrix} a \\ b \end{bmatrix} + \begin{bmatrix} c \\ d \end{bmatrix} = \begin{bmatrix} a + c \\ b + d \end{bmatrix}$  is the matrix of the composite translation which follows the familiar "parallelogram law" for adding translations (or vectors). Now,  $\begin{bmatrix} a & c \\ b & d \end{bmatrix} \cdot \begin{bmatrix} x \\ y \end{bmatrix}$  may be "decomposed" into  $x \begin{bmatrix} a \\ b \end{bmatrix} + y \begin{bmatrix} c \\ d \end{bmatrix}$ . Thus  $\begin{bmatrix} a & c \\ b & d \end{bmatrix} \cdot \begin{bmatrix} x \\ y \end{bmatrix}$  may be viewed as the sum of two 2 x 1 matrices, each multiplied by a scalar. Hence, the image of each (x,y) is obtained as the sum of two vectors. If you like, this can be taught in connection with Exercises 4-8 in Section 1.12. For instance  $\begin{bmatrix} 2 & 3 \\ 1 & 2 \end{bmatrix} \cdot \begin{bmatrix} x \\ y \end{bmatrix}$  may be regarded as  $x \begin{bmatrix} 2 \\ 1 \end{bmatrix} + y \begin{bmatrix} 3 \\ 2 \end{bmatrix}$  or  $\begin{bmatrix} 2x \\ x \end{bmatrix} + \begin{bmatrix} 3y \\ 2y \end{bmatrix}$ . The image of (1,2) is found by the addition  $\begin{bmatrix} 2 \\ 1 \end{bmatrix} + \begin{bmatrix} 6 \\ 4 \end{bmatrix} = \begin{bmatrix} 8 \\ 5 \end{bmatrix}$ . The image is (8,5). In this manner we find that the image of the unit square, with vertices (0,0), (1,0), (1,1), (0,1) is the parallelogram with vertices (0,0), (2,1), (5,3), (3,2). This suggests how the entire plane, viewed as a network of squares, is transformed onto a network of parallelograms. (See Matthews, Matrices 2, pages 20-23).

### 1.10 Exercise Solutions

1. a.  $\begin{bmatrix} 1 & 0 \\ 0 & -1 \end{bmatrix} \cdot \begin{bmatrix} 3 \\ -2 \end{bmatrix} = \begin{bmatrix} 3 \\ 2 \end{bmatrix}$

The image is (3,2).

b.  $\begin{bmatrix} -1 & 0 \\ 0 & 1 \end{bmatrix} \cdot \begin{bmatrix} 3 \\ -2 \end{bmatrix} = \begin{bmatrix} -3 \\ -2 \end{bmatrix}$

The image is (-3,-2).

c.  $\begin{bmatrix} 0 & 1 \\ 1 & 0 \end{bmatrix} \cdot \begin{bmatrix} 3 \\ -2 \end{bmatrix} = \begin{bmatrix} -2 \\ 3 \end{bmatrix}$  The image is  $(-2, 3)$ .

d.  $\begin{bmatrix} 0 & -1 \\ 1 & 0 \end{bmatrix} \cdot \begin{bmatrix} 3 \\ -2 \end{bmatrix} = \begin{bmatrix} 2 \\ 3 \end{bmatrix}$  The image is  $(2, 3)$ .

e.  $\begin{bmatrix} -1 & 0 \\ 0 & -1 \end{bmatrix} \cdot \begin{bmatrix} 3 \\ -2 \end{bmatrix} = \begin{bmatrix} -3 \\ 2 \end{bmatrix}$  The image is  $(-3, 2)$ .

f.  $\begin{bmatrix} 3 & 0 \\ 0 & 3 \end{bmatrix} \cdot \begin{bmatrix} 3 \\ -2 \end{bmatrix} = \begin{bmatrix} 9 \\ -6 \end{bmatrix}$  The image is  $(9, -6)$ .

2. a.  $\begin{bmatrix} 1 & 0 \\ 0 & -1 \end{bmatrix} \cdot \begin{bmatrix} -1 & 0 \\ 0 & -1 \end{bmatrix} \cdot \begin{bmatrix} -2 \\ 0 \end{bmatrix} = \begin{bmatrix} 2 \\ 0 \end{bmatrix}$  The image is  $(2, 0)$ .

b.  $\begin{bmatrix} 0 & 1 \\ 1 & 0 \end{bmatrix} \cdot \begin{bmatrix} -1 & 0 \\ 0 & -1 \end{bmatrix} \cdot \begin{bmatrix} -2 \\ 0 \end{bmatrix} = \begin{bmatrix} 0 \\ 2 \end{bmatrix}$  The image is  $(0, 2)$ .

c.  $\begin{bmatrix} 0 & -1 \\ 1 & 0 \end{bmatrix} \cdot \begin{bmatrix} -1 & 0 \\ 0 & -1 \end{bmatrix} \cdot \begin{bmatrix} -2 \\ 0 \end{bmatrix} = \begin{bmatrix} 0 \\ 2 \end{bmatrix}$  The image is  $(0, 2)$ .

d.  $\begin{bmatrix} -1 & 0 \\ 0 & -1 \end{bmatrix} \cdot \begin{bmatrix} 0 & -1 \\ 1 & 0 \end{bmatrix} \cdot \begin{bmatrix} -2 \\ 0 \end{bmatrix} = \begin{bmatrix} 0 \\ 2 \end{bmatrix}$  The image is  $(0, 2)$ .

e.  $\begin{bmatrix} 4 & 0 \\ 0 & 4 \end{bmatrix} \cdot \begin{bmatrix} 0 & 1 \\ 1 & 0 \end{bmatrix} \cdot \begin{bmatrix} -2 \\ 0 \end{bmatrix} = \begin{bmatrix} 0 \\ -8 \end{bmatrix}$  The image is  $(0, -8)$ .

f.  $\begin{bmatrix} 0 & 1 \\ 1 & 0 \end{bmatrix} \cdot \begin{bmatrix} 4 & 0 \\ 0 & 4 \end{bmatrix} \cdot \begin{bmatrix} -2 \\ 0 \end{bmatrix} = \begin{bmatrix} 0 \\ -8 \end{bmatrix}$  The image is  $(0, -8)$ .

3. a.  $\begin{bmatrix} -1 & 0 \\ 0 & -1 \end{bmatrix} \cdot \begin{bmatrix} 1 & 1 \\ 0 & 1 \end{bmatrix} = \begin{bmatrix} -1 & -1 \\ 0 & -1 \end{bmatrix}$

b.  $\begin{bmatrix} 1 & 1 \\ 0 & 1 \end{bmatrix} \cdot \begin{bmatrix} -1 & 0 \\ 0 & -1 \end{bmatrix} = \begin{bmatrix} -1 & -1 \\ 0 & -1 \end{bmatrix}$

c.  $\begin{bmatrix} 1 & 1 \\ 0 & 1 \end{bmatrix} \cdot \begin{bmatrix} -2 & 0 \\ 0 & -2 \end{bmatrix} = \begin{bmatrix} -2 & -2 \\ 0 & -2 \end{bmatrix}$

d. 
$$\begin{bmatrix} -2 & 0 \\ 0 & -2 \end{bmatrix} \cdot \begin{bmatrix} 1 & 1 \\ 0 & 1 \end{bmatrix} = \begin{bmatrix} -2 & -2 \\ 0 & -2 \end{bmatrix}$$

e. 
$$\begin{bmatrix} -2 & 0 \\ 0 & -2 \end{bmatrix} \cdot \begin{bmatrix} -2 & 0 \\ 0 & -2 \end{bmatrix} = \begin{bmatrix} 4 & 0 \\ 0 & 4 \end{bmatrix}$$

4. a. Each point is its own image. The transformation is the identity transformation.
- b.  $(0,0) \longrightarrow (0,0)$ ;  $(1,0) \longrightarrow (1,1)$ ;  $(0,1) \longrightarrow (0,1)$ ;  
 $(1,1) \longrightarrow (1,2)$ . This is a shear with rule  
 $(x,y) \longrightarrow (x, x + y)$ .
- c.  $(0,0) \longrightarrow (0,0)$ ;  $(1,0) \longrightarrow (0,-1)$ ,  $(0,1) \longrightarrow (1,-1)$ ,  
 $(1,1) \longrightarrow (1,-2)$ . This is  $R_y$  followed by  $R_x$ , followed  
 by shear with matrix  $\begin{bmatrix} 1 & 0 \\ -1 & 1 \end{bmatrix}$ . These are determined  
 by noting how to transform square with vertices  $(0,0)$ ,  
 $(1,0)$ ,  $(1,1)$ ,  $(0,1)$  into the parallelogram with  
 vertices  $(0,0)$ ,  $(0,-1)$ ,  $(1,-2)$ ,  $(1,-1)$ .

Also acceptable is the answer: the transformation  
 with rule  $(x,y) \longrightarrow (y, -x - y)$ .

- d.  $(0,0) \longrightarrow (0,0)$ ,  $(1,0) \longrightarrow (-1,0)$ ,  $(0,1) \longrightarrow (1,1)$ ,  
 $(1,1) \longrightarrow (0,1)$ . This transformation maps  $(x,y)$  onto  
 $(-x + y, y)$ .
- e.  $(0,0) \longrightarrow (0,0)$ ,  $(1,0) \longrightarrow (2,0)$ ,  $(0,1) \longrightarrow (0,1)$ ,  
 $(1,1) \longrightarrow (2,1)$ . In general  $(x,y) \longrightarrow (2x,y)$ . This  
 moves a point along a line parallel to the x-axis  
 $(y \longrightarrow y)$  and twice as far from the y-axis  $(x \longrightarrow 2x)$ .
- f.  $(0,0) \longrightarrow (0,0)$ ;  $(1,0) \longrightarrow (2,1)$ ,  $(0,1) \longrightarrow (1,1)$ ,  
 $(1,1) \longrightarrow (3,2)$ . In this transformation  
 $(x,y) \longrightarrow (2x + y, x + y)$ .

g.  $(0,0) \longrightarrow (0,0)$ ;  $(1,0) \longrightarrow (2,0)$ ,  $(0,1) \longrightarrow (0,2)$ ,  
 $(1,1) \longrightarrow (2,2)$ . In this transformation  
 $(x,y) \longrightarrow (2x,2y)$ . It is a dilation with scale factor  
2.

h.  $\begin{bmatrix} 0 & 1 \\ 1 & 0 \end{bmatrix} + \begin{bmatrix} 0 & 1 \\ 0 & 0 \end{bmatrix} = \begin{bmatrix} 0 & 2 \\ 1 & 0 \end{bmatrix} \therefore (0,0) \longrightarrow (0,0),$   
 $(1,0) \longrightarrow (0,1),$   
 $(0,1) \longrightarrow (2,0)$ ,  $(1,1) \longrightarrow (2,1)$ . In general,  
 $(x,y) \longrightarrow (2y,x)$ . It can be regarded as a motion  
parallel to the y-axis ( $x \longrightarrow x$ ) and twice as far  
from the x-axis ( $y \longrightarrow 2y$ ), followed by  $R_x$ .

5.  $(3,2) \longrightarrow (5,5)$  and  $(2,3) \longrightarrow (5,5)$ . Therefore the mapping  
is not 1-1. Hence it is not a transformation.

6. The rule of this transformation is  $(x,y) \longrightarrow (2x, x + y)$ .  
One can describe it as moving a point parallel to the  
x-axis to another twice as far from the y-axis as the  
first (the effect of  $2x$ ) and raising it (or lowering it)  
a directed distance of  $y$  (the effect of  $x + y$ ).

7. The rule is  $(x,y) \longrightarrow (3x,y)$ . This keeps a point at the  
same distance from the x-axis ( $y \longrightarrow y$ ) and triples its  
distance from the y-axis ( $x \longrightarrow 3x$ ).

8. C has the rule  $(x,y) \longrightarrow (2x + 3y, x + 2y)$ .  
D has the rule  $(x,y) \longrightarrow (2x - 3y, -x + 2y)$ .  
In either order the composition is  $i$ , with rule  
 $(x,y) \longrightarrow (x,y)$ .

9. For space transformations we use  $3 \times 3$  matrices. Some  
examples follow.

The reflection in the xy-plane has the rule

$$(x, y, z) \longrightarrow (x, y, -z).$$

The matrix for this rule is 
$$\begin{bmatrix} 1 & 0 & 0 \\ 0 & 1 & 0 \\ 0 & 0 & -1 \end{bmatrix}$$

The reflection in the origin 0 has the rule

$$(x, y, z) \longrightarrow (-x, -y, -z).$$

The matrix for this rule is 
$$\begin{bmatrix} -1 & 0 & 0 \\ 0 & -1 & 0 \\ 0 & 0 & -1 \end{bmatrix}$$

The reflection in the x-axis has the rule

$$(x, y, z) \longrightarrow (x, -y, -z).$$

The matrix for this rule is 
$$\begin{bmatrix} 1 & 0 & 0 \\ 0 & -1 & 0 \\ 0 & 0 & -1 \end{bmatrix}$$

The dilation with center 0 and scale factor 2 has the rule

$$(x, y, z) \longrightarrow (2x, 2y, 2z).$$

The matrix for this rule is 
$$\begin{bmatrix} 2 & 0 & 0 \\ 0 & 2 & 0 \\ 0 & 0 & 2 \end{bmatrix}$$

The  $90^\circ$  rotation about the x-axis has rule

$$(x, y, z) \longrightarrow (x, -z, y)$$

and the matrix for this rule is

$$\begin{bmatrix} 1 & 0 & 0 \\ 0 & 0 & -1 \\ 0 & 1 & 0 \end{bmatrix}$$

1.11 Transition Matrices (Time for 1.11 and 1.12 = 1 to  $\frac{1}{2}$  days)

We have deliberately chosen transition matrices in which the sum of entries in each row is one. Then each of these matrices may also be considered a stochastic matrix and the entries are known as transition probabilities. A sequence of calculations in which we start with a set of states and calculate consecutive stages of states (as we do for the population of a city and its suburb) is a Markov Chain.

However a transition matrix need not be a stochastic matrix. Had we allowed for an increase in the total population of our example then the sum of the entries in a row would have been more than one, and hence, they would no longer be transition probabilities - and neither would the matrix be a stochastic one.

For additional examples of a Markov Chain see Kemeny, Snell, Thompson: Introduction to Finite Mathematics, Prentice Hall, pages 171-175.

1.12 Exercise Solutions

1. (a)  $[4,830,000, 2,170,000] \cdot \begin{bmatrix} .9 & .1 \\ .2 & .8 \end{bmatrix} = [4,781,000, 2,219,000]$

(b)

	1963 to 1964	1964 to 1965	1965 to 1966
changes in city population	- 100,000	- 70,000	- 49,000
changes in suburb population	+ 100,000	+ 70,000	+ 49,000



The absolute values of the changes are smaller and smaller, and presumably continue in this manner to approximate zero. This is the mathematical way of describing a tendency to stability.

$$2. \quad (a) \quad \begin{bmatrix} 100 & 0 \end{bmatrix} \cdot \begin{bmatrix} .98 & .02 \\ .01 & .99 \end{bmatrix} = \begin{bmatrix} 98 & 2 \end{bmatrix}$$

$$(b) \quad \begin{bmatrix} 98 & 2 \end{bmatrix} \cdot \begin{bmatrix} .98 & .02 \\ .01 & .99 \end{bmatrix} = \begin{bmatrix} 96.06 & 3.94 \end{bmatrix}$$

$$(c) \quad \begin{bmatrix} 96.06 & 3.94 \end{bmatrix} \cdot \begin{bmatrix} .98 & .02 \\ .01 & .99 \end{bmatrix} = \begin{bmatrix} 94.1782 & 5.8218 \end{bmatrix}$$

3. The changes in water vapor in successive hours are + 2, + 1.94, + 1.8818, indicating a constantly increasing amount of vapor - even though the amount of increase is slowly decreasing. This would suggest (not prove) that the sequence of vapor changes has a lower bound 0. This would imply that the amount of water vapor has a greatest lower bound - hence eventual stability. However the data collected for three hours only suggests this stability. More data would make this argument more plausible and mathematical theory (involving characteristic values of the transition matrix) would prove the conclusion of stability.

$$4. \quad (a) \quad \begin{bmatrix} .9 & .1 \\ .2 & .8 \end{bmatrix} \cdot \begin{bmatrix} .9 & .1 \\ .2 & .8 \end{bmatrix} = \begin{bmatrix} .83 & .17 \\ .34 & .66 \end{bmatrix}$$

$$(b) \quad \begin{bmatrix} .98 & .02 \\ .01 & .99 \end{bmatrix} \cdot \begin{bmatrix} .98 & .02 \\ .01 & .99 \end{bmatrix} = \begin{bmatrix} .9606 & .0394 \\ .0197 & .9803 \end{bmatrix}$$

5. To find the 1962 population from the 1963 population

multiply

$[5,000,000 \ 2,000,000]$  by the inverse of the transition matrix. Thus, if  $A$  is the transition matrix, and  $[x,y]$  is the 1962 population,

$$[5,000,000 \ 2,000,000] \cdot A^{-1} = [x,y].$$

$$\text{because } [5,000,000 \ 2,000,000] \cdot A^{-1} \cdot A = [x,y] \cdot A$$

$$\text{or } [5,000,000 \ 2,000,000] = [x,y] \cdot A$$

as required.

1.14 Exercise Solutions (Time for summary and 1.14 = 1 day)

1.	(a)	$AB = \begin{bmatrix} 28 & 42 \\ 0 & 14 \end{bmatrix}$	$BA = \begin{bmatrix} 14 & 28 \\ 0 & 28 \end{bmatrix}$
	(b)	$AB = \begin{bmatrix} 6 & 0 \\ 3 & 0 \end{bmatrix}$	$BA = \begin{bmatrix} 4 & 2 \\ 4 & 2 \end{bmatrix}$
	(c)	$AB = \begin{bmatrix} p & q \\ r & s \end{bmatrix}$	$BA = \begin{bmatrix} p & q \\ r & s \end{bmatrix}$
	(d)	$AB = \begin{bmatrix} 0 & -1 \\ 1 & 15 \end{bmatrix}$	$BA = \begin{bmatrix} 10 & -1 \\ -49 & 5 \end{bmatrix}$

2. In each case  $A + B = B + A$

a.	$\begin{bmatrix} 7 & 6 \\ 1 & 8 \end{bmatrix}$	b.	$\begin{bmatrix} 5 & 2 \\ 3 & 1 \end{bmatrix}$	c.	$\begin{bmatrix} p+1 & q \\ r & s+1 \end{bmatrix}$	d.	$\begin{bmatrix} 1 & -1 \\ -9 & 6 \end{bmatrix}$
----	--	----	--	----	--	----	--

3.  $2A + 2B = 2 \begin{bmatrix} 3 & 8 \\ -1 & 2 \end{bmatrix} + 2 \begin{bmatrix} 4 & -2 \\ 2 & 6 \end{bmatrix} = \begin{bmatrix} 6 & 16 \\ -2 & 4 \end{bmatrix} + \begin{bmatrix} 8 & -4 \\ 4 & 12 \end{bmatrix}$

$$= \begin{bmatrix} 14 & 12 \\ 2 & 16 \end{bmatrix}$$

4. (a)  $\begin{bmatrix} 3 & 2 \\ 6 & 4 \end{bmatrix} \cdot \begin{bmatrix} -2 & 2 \\ 3 & -3 \end{bmatrix} = \begin{bmatrix} 0 & 0 \\ 0 & 0 \end{bmatrix}$

(b) 
$$\begin{bmatrix} 3 & 2 \\ 6 & 4 \end{bmatrix} + \begin{bmatrix} -3 & -2 \\ -6 & -4 \end{bmatrix} = \begin{bmatrix} 0 & 0 \\ 0 & 0 \end{bmatrix}$$

5. (a) WILL COME SOON 
$$\begin{bmatrix} 23 & 9 \\ 12 & 12 \end{bmatrix}, \begin{bmatrix} 3 & 15 \\ 13 & 5 \end{bmatrix}, \begin{bmatrix} 19 & 15 \\ 15 & 14 \end{bmatrix}$$

Which on multiplying on the right by 
$$\begin{bmatrix} 3 & 1 \\ 5 & 2 \end{bmatrix}$$
 becomes

$$\begin{bmatrix} 114 & 41 \\ 96 & 36 \end{bmatrix}, \begin{bmatrix} 84 & 33 \\ 64 & 23 \end{bmatrix}, \begin{bmatrix} 132 & 49 \\ 115 & 43 \end{bmatrix}$$

$$114 \ 41 \ 96 \ 36 \ 84 \ 33 \ 64 \ 23 \ 132 \ 49 \ 115 \ 43.$$

(b) 
$$\begin{bmatrix} 114 & 41 \\ 96 & 36 \end{bmatrix}, \begin{bmatrix} 84 & 33 \\ 64 & 23 \end{bmatrix}, \begin{bmatrix} 132 & 49 \\ 115 & 43 \end{bmatrix}$$
 on multiplying the

right by 
$$\begin{bmatrix} 2 & -1 \\ -5 & 3 \end{bmatrix}$$
 becomes 
$$\begin{bmatrix} 23 & 9 \\ 12 & 12 \end{bmatrix}, \begin{bmatrix} 3 & 15 \\ 13 & 5 \end{bmatrix}, \begin{bmatrix} 19 & 15 \\ 15 & 14 \end{bmatrix}$$

WILL COME SOON.

6. a. 
$$\begin{bmatrix} 2 & -1 \\ -5 & 3 \end{bmatrix} \cdot \begin{bmatrix} 9 \\ 16 \end{bmatrix} = \begin{bmatrix} 2 \\ 3 \end{bmatrix}$$

$(x, y) = (2, 3)$

Check: 
$$3(2) + (3) = 9$$
  

$$5(2) + 2(3) = 16$$

b. 
$$\begin{bmatrix} 2 & -1 \\ -5 & 3 \end{bmatrix} \cdot \begin{bmatrix} 3 \\ 4 \end{bmatrix} = \begin{bmatrix} 2 \\ -3 \end{bmatrix}$$

$(x, y) = (2, -3)$

Check: 
$$3(2) + (-3) = 3$$
  

$$5(2) + 2(-3) = 4$$

c. 
$$\begin{bmatrix} 3 & 1 \\ 5 & 2 \end{bmatrix} \cdot \begin{bmatrix} -1 \\ 1 \end{bmatrix} = \begin{bmatrix} -2 \\ -3 \end{bmatrix}$$

$(x, y) = (-2, -3)$

Check: 
$$2(-2) - (-3) = -1$$
  

$$-5(-2) + 3(-3) = 1$$

d. 
$$\begin{bmatrix} 3 & 1 \\ 5 & 2 \end{bmatrix} \cdot \begin{bmatrix} 0 \\ 0 \end{bmatrix} = \begin{bmatrix} 0 \\ 0 \end{bmatrix}$$

$(x, y) = (0, 0)$

Check: 
$$2(0) - (0) = 0$$
  

$$-5(0) + 3(0) = 0$$

7. 
$$\begin{bmatrix} 0 & 1 & 0 \\ 1 & 0 & 0 \\ 0 & 0 & 1 \end{bmatrix} \cdot \begin{bmatrix} a & b & c \\ d & e & f \\ g & h & i \end{bmatrix} = \begin{bmatrix} d & e & f \\ a & b & c \\ g & h & i \end{bmatrix}$$

The product may be obtained from the second matrix by interchanging the first and second rows.

8. 

	A	B	C
A	0	2	0
B	2	0	1
C	0	1	0

	A	B	C	D
A	0	1	0	1
B	1	0	1	0
C	0	1	0	0
D	1	0	0	0

c. 

	A	B	C	D
A	0	1	1	1
B	1	0	1	1
C	1	1	0	1
D	1	1	1	0

9. a. 
$$\begin{bmatrix} 3,000,000 & 3,000,000 \\ 2,700,000 & 3,300,000 \\ 2,700,000 & 3,300,000 \\ 2,550,000 & 3,450,000 \\ 2,550,000 & 3,450,000 \\ 2,475,000 & 3,525,000 \end{bmatrix} \cdot \begin{bmatrix} .7 & .3 \\ .2 & .8 \end{bmatrix} =$$

Suggested Test Items

1. A dealer sells three kinds of cars, A, B, C in two sales offices I, II. His sales for the month of January are shown in matrix P, and those of February are shown in matrix Q. The prices of cars are shown in matrix R.

	A	B	C
I	6	3	4
II	3	4	2

P

	A	B	C
I	5	7	1
II	3	4	5

Q

A	2000
B	2500
C	3000

R

Using matrix operations, showing all work, find:

- a. The total number of each kind of car sold, in each office, for both months.
  - b. The total number of each car sold, in each office, during March, assuming that the March sales are double the February sales.
  - c. The sales revenue for the January sales in each office.
2. The matrix of  $r_{90}$  is  $\begin{bmatrix} 0 & -1 \\ 1 & 0 \end{bmatrix}$  and that of dilation  $D_2$  is  $\begin{bmatrix} 2 & 0 \\ 0 & 2 \end{bmatrix}$ .
- a. Find the image of  $(-3, 5)$  under  $r_{90}$  and also under  $D_2$  using matrix operations.
  - b. Find the matrix of the composition of  $r_{90}$  followed by  $D_2$ .
  - c. Using matrices, determine whether or not  $r_{90} \circ D_2 = D_2 \circ r_{90}$ .

3. Express as a single matrix.

$$\left( \begin{bmatrix} 3 \\ 2 \\ -1 \\ 2 \end{bmatrix} + 5 \begin{bmatrix} 0 \\ 1 \\ 1 \\ 2 \end{bmatrix} \right) \cdot [2 \quad 5 \quad -1]$$

4. In coding a message with matrix  $\begin{bmatrix} 3 & 2 \\ 4 & 3 \end{bmatrix}$  the appropriate decoding matrix is  $\begin{bmatrix} 3 & -2 \\ -4 & 3 \end{bmatrix}$ ; using this information solve and check:

a.  $3x + 2y = 4$   
 $4x + 3y = 5$

b.  $3x - 2y = -8$   
 $-4x + 3y = 11$

5. Devise a matrix for each of the following two way bus routes depicted below

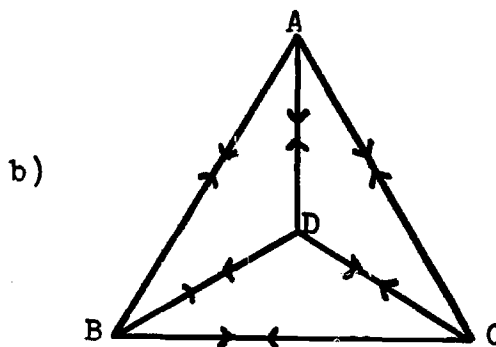
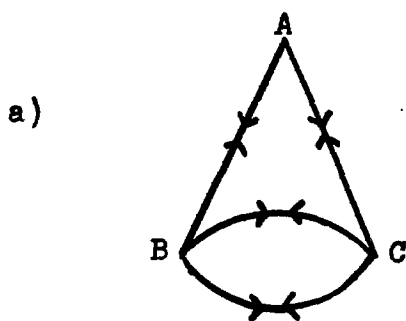

6. The population of a city at the end of 1968 is 5,000,000 and that of its suburbs is 3,000,000. Assume that 80 % of the city people in any year, remain in the city and 20 % of them move to the suburbs, while 90 % of the suburban population remain in the suburbs and 10 % of them move to the city.

Using matrices, calculate the population in both city and suburbs, at the end of 1970.

Solutions of Test Items.

1. a.  $P + Q = \begin{bmatrix} 11 & 10 & 5 \\ 6 & 8 & 7 \end{bmatrix}$

b.  $2Q = \begin{bmatrix} 10 & 14 & 2 \\ 6 & 8 & 10 \end{bmatrix}$

c.  $P \cdot R = \begin{bmatrix} (6 \cdot 2000) + (3 \cdot 2500) + (4 \cdot 3000) \\ (3 \cdot 2000) + (4 \cdot 2500) + (2 \cdot 3000) \end{bmatrix} = \begin{bmatrix} 31,500 \\ 22,000 \end{bmatrix}$

2. a.  $\begin{bmatrix} 0 & -1 \\ 1 & 0 \end{bmatrix} \cdot \begin{bmatrix} -3 \\ 5 \end{bmatrix} = \begin{bmatrix} -5 \\ -3 \end{bmatrix}$   $(-3, 5) \xrightarrow{r_{e0}} (-5, -3)$

$\begin{bmatrix} 2 & 0 \\ 0 & 2 \end{bmatrix} \cdot \begin{bmatrix} -3 \\ 5 \end{bmatrix} = \begin{bmatrix} -6 \\ 10 \end{bmatrix}$   $(-3, 5) \xrightarrow{D_2} (-6, 10)$

b.  $\begin{bmatrix} 2 & 0 \\ 0 & 2 \end{bmatrix} \cdot \begin{bmatrix} 0 & -1 \\ 1 & 0 \end{bmatrix} = \begin{bmatrix} 0 & -2 \\ 2 & 0 \end{bmatrix}$

c.  $\begin{bmatrix} 0 & -1 \\ 1 & 0 \end{bmatrix} \cdot \begin{bmatrix} 2 & 0 \\ 0 & 2 \end{bmatrix} = \begin{bmatrix} 0 & -2 \\ 2 & 0 \end{bmatrix} \therefore r_{e0} \circ D_2 = D_2 \circ r_{e0}$

3.  $\left( 2 \begin{bmatrix} 3 \\ -1 \\ 2 \end{bmatrix} + 5 \begin{bmatrix} 0 \\ 1 \\ 2 \end{bmatrix} \right) \cdot [2 \ 5 \ -1] = \begin{bmatrix} 6 \\ 3 \\ 14 \end{bmatrix} \cdot [2 \ 5 \ -1] =$

$\begin{bmatrix} 12 & 30 & -6 \\ 6 & 15 & -3 \\ 28 & 70 & -14 \end{bmatrix}$

4. a.  $\begin{bmatrix} 3 & -2 \\ -4 & 3 \end{bmatrix} \cdot \begin{bmatrix} 4 \\ 5 \end{bmatrix} = \begin{bmatrix} 2 \\ -1 \end{bmatrix} \quad (x, y) = (2, -1)$

Check:  $3(2) + 2(-1) = 4$   
 $4(2) + 3(-1) = 5$

b.  $\begin{bmatrix} 3 & 2 \\ 4 & 3 \end{bmatrix} \cdot \begin{bmatrix} -8 \\ 11 \end{bmatrix} = \begin{bmatrix} -2 \\ 1 \end{bmatrix} \quad (x,y) = (-2,1)$

Check:  $3(-2) - 2(1) = -8$   
 $-4(-2) + 3(1) = 11$

5. a.

	A	B	C
A	0	1	1
B	1	0	2
C	1	2	0

b.

	A	B	C	D
A	0	1	1	1
B	1	0	1	1
C	1	1	0	1
D	1	1	1	0

6. Solution method 1:

$$\begin{bmatrix} 5,000,000 & 3,000,000 \\ 4,300,000 & 3,700,000 \end{bmatrix} \cdot \begin{bmatrix} .8 & .2 \\ .1 & .9 \end{bmatrix} =$$

$$\begin{bmatrix} 4,300,000 & 3,700,000 \\ 3,810,000 & 4,190,000 \end{bmatrix} \cdot \begin{bmatrix} .8 & .2 \\ .1 & .9 \end{bmatrix} =$$

Population of city at the end of 1970 is 3,810,000 and the population of the suburbs is 4,190,000.

Solution method 2:

$$\begin{bmatrix} 5,000,000 & 3,000,000 \\ 3,810,000 & 4,190,000 \end{bmatrix} \cdot \begin{bmatrix} .8 & .2 \\ .1 & .9 \end{bmatrix} \cdot \begin{bmatrix} .8 & .2 \\ .1 & .9 \end{bmatrix} =$$

$$\begin{bmatrix} 5,000,000 & 3,000,000 \\ 3,810,000 & 4,190,000 \end{bmatrix} \cdot \begin{bmatrix} .66 & .34 \\ .17 & .83 \end{bmatrix} =$$



## Chapter 2

### LINEAR EQUATIONS AND MATRICES

Time Estimate: 13 - 15 days

The main objective of this chapter is to solve systems of linear equations by means of tableaux, and operations on tableaux.

It is important from the very outset to understand that a tableau is not a crutch, in the sense that this term is used among teachers to describe a device that helps students to overcome a difficulty and is then discarded. The tableau, indeed a helpful device, is not discarded. It is used in this chapter to answer many questions about solving systems of linear equations; it is used again in all subsequent chapters where systems of equalities and systems of inequalities are to be solved; it is used in the simplex method to solve linear programming problems; it is used again in linear transformations.

A tableau is an orderly way of writing a system of linear equations or inequalities. It reveals simply and quickly the coefficients, detached but not entirely removed, of variables, and constants. That this is a sensible arrangement follows from the fact that solutions of systems operate on the coefficients and constants, not on the variables. This and the fact that tableaux are easily related to matrices have induced modern mathematicians to use them extensively. Another advantage of tableaux is that they can be used in computer programs to solve a system of hundreds of linear equations in hundreds of variables.

The tableau is a short step from a data table. When a problem contains many facts and relations it is advisable to arrange the data in a table. This has been the practice in teaching the conventional rate-time-distance problems or age problems, to mention only two types. To illustrate with a variation of a rate-time-distance problem: Two men start at a point and move in opposite directions, one at the rate of 30 m.p.h., the other at 40 m.p.h. After the first travels  $x$  hours and the second  $y$  hours, they are 250 miles apart. If their respective rates had been 35 and 45 m.p.h. That distance would have been 285 miles. Put in a data table form, this can be recorded as follows:

	DISTANCE		
A	30	40	250
B	35	45	285

Then the equations are

$$30x + 40y = 250$$

$$35x + 45y = 285.$$

How simple it is to convert the data table to a tableau by writing the variables at the top of columns as follows

x	y	-1	
30	40	250	= 0
35	45	285	= 0

Once the student has learned to pivot on an entry in the tableau, the method of solution is simple and direct. The method is the same for a system of 100 equations in 200 variables.

ERIC in this sense, the tableau, together with the pivotal operation,

becomes an operational system. Summarizing, a tableau incorporates three basically important features.

- (1) It organizes a complex set of data.
- (2) It is a simple way to write a system of linear relations.
- (3) It serves in an operational system to solve the system.

## 2.1 Linear Combinations of Equations ( $1\frac{1}{2}$ - 2 days)

In this section we try to clarify the nature of a system of linear equations. Such a system is a conjunction of open sentences. The conjunction is true if each component is true. Hence the solution set of the system is the intersection of the solution sets of the component equations. The focus of this section is to see how the solution sets of equations are affected by the two elementary operations performed on equations. In the first of these operations the equation is multiplied by a non-zero constant, and the solution set is unaltered. In the second operation an equation in a system is replaced by the sum of itself and a multiple of another. This leaves the solution set of the system unaltered. The second operation is a special case of linear combinations, a notion that assumes more and more importance in subsequent studies.

Observe the notation by which a system is represented by a capital letter, such as A, and its component equations are represented by the letter with subscripts. If system A has

three equations they are called  $A_1$ ,  $A_2$ ,  $A_3$ .

The crucial ideas of this section are found in Theorems 1 and 2.

## 2.2 Exercise Solutions

1. (a)  $10x + 2y = 6$   
 (b)  $x + \frac{1}{5}y = \frac{3}{5}$   
 (c)  $-\frac{5}{3}x - \frac{1}{3}y = -1$
2. (a)  $x - \frac{2}{3}y = -2$   
 (b)  $-\frac{3}{2}x + y = +33$
3. (a)  $3x + 2y = 0$   
 (b)  $5x + y = 7$   
 (c)  $-7y = 21$   
 (d)  $-\frac{7}{2}y = \frac{21}{2}$   
 (e)  $\frac{7}{3}x = \frac{14}{3}$   
 (f)  $7x = 14$
4. (a)  $m = 3$  (b)  $n = -2$
5. (a)  $m = -2$  (b)  $n = 2$  (c)  $k = 2$

\*6.  $A \quad ax + by = c \quad A_1$   
 $\quad \quad a'x + b'y = c' \quad A_2$

$x + \frac{b}{a}y = \frac{c}{a} \quad B_1 = \frac{1}{a}A_1$

$B \quad 0x + \frac{ab' - a'b}{a}y = \frac{ac' - a'c}{a} \quad B_2 = A_2 - a'B$

$C \quad x + 0y = \frac{b'c - bc'}{ab' - a'b} \quad C_1 = B_1 - \frac{b}{a}C_2$

$0x + y = \frac{ac' - a'c}{ab' - a'b} \quad C_2 = \frac{a}{ab' - a'b} B_2$

If  $a_1b = a_1'b$ ,  $B_2$  is  $Ox + Oy = \frac{ac' - a_1c}{a}$ . This equation has no solution if  $ac' \neq a_1c$  and is satisfied by all  $(x, y)$  if  $ac' = a_1c$ . In the latter case system A is equivalent to one of its equations.

### 2.3 Pivotal Operations ( $2\frac{1}{2}$ - 3 days)

The aim of these operations is to convert all coefficients of a variable into zeros and if possible, one "1". It is iterated as many times as are possible. These operations produce a sequence of equivalent systems, whose solution sets are the same. If it is possible to reduce a system so that each variable has zero coefficients and one "1", then the system has a unique solution that is easily read in the "-1" column. Otherwise, the system has either no solutions or an infinite number of solutions.

The pivotal operations were first invented by Gauss to "diagonalize" a system. In this form all entries below diagonal entries are zeros. It was extended by Jordan (a French engineer) to obtain zeros above diagonal entries which are hopefully all "1"'s.

We have tried to effect a gradual transition from using pivotal operations on equations, written in the classic manner, to rows of a tableau. It is important in this transition to stop and retrieve equations from tableaus at various stages of the Gauss-Jordan reduction, in order that the student acquire the conviction that pivotal operations are based in an intelligent procedure - not only mechanical.

In this section we confine ourselves to systems that have unique solutions. Others are considered in Section 2.5.

### 2.4 Exercise Solutions

1.

	x	y	-1
①	3	10	
2	5	16	
1	3	10	
0	①	-4	
1	0	-2	
0	1	4	

$(x, y) = (-2, 4)$

2.

	x	y	-1
②	3	10	
2	1	6	
1	$\frac{3}{2}$	5	
0	②	-4	
1	0	2	
0	1	2	

$(x, y) = (2, 2)$

3.

	x	y	-1
	5	-3	12
②	-1	5	
0	①	$-\frac{1}{2}$	$-\frac{1}{2}$
1	$-\frac{1}{2}$	$\frac{5}{2}$	
0	1	1	
1	0	3	

$(x, y) = (3, 1)$

4.

	u	v	-1
	5	3	27
6	②	10	
①	0	12	
3	1	5	
1	0	-3	
0	1	14	

$(u, v) = (-3, 14)$

5. r s -1

②	4	1
4	-3	1
1	2	$\frac{1}{2}$
0	①-11	-1
1	0	$\frac{7}{12}$
0	1	$\frac{1}{11}$

$$(r, s) = \left(\frac{7}{22}, \frac{1}{11}\right)$$

6. x y -1

3	4	13
-5	①	4
②3	0	1
-5	1	4
1	0	$\frac{1}{23}$
0	1	$\frac{97}{23}$

$$(x, y) = \left(\frac{1}{23}, \frac{97}{23}\right)$$

7. x y z -1

①	1	-1	-2
1	-2	-2	1
2	3	1	1
1	1	-1	-2
0	③-3	-1	3
0	1	3	5
1	0	$\frac{4}{3}$	-1
0	1	$\frac{1}{3}$	-1
0	0	⑧-8 3	6
1	0	0	$\frac{8}{4}$
0	1	0	$\frac{7}{4}$
0	0	1	$\frac{9}{4}$

$$(x, y, z) = \left(2, \frac{7}{4}, \frac{9}{4}\right)$$

8. x y z -1

①	0	4	4
2	1	1	3
-1	1	1	1
1	0	4	4
0	①	-7	-5
0	1	5	5
1	0	4	4
0	1	-7	-5
0	0	①-12	-10
1	0	0	$\frac{2}{3}$
0	1	0	$\frac{5}{6}$
0	0	1	$\frac{5}{6}$

$$(x, y, z) = \left(\frac{2}{3}, \frac{5}{6}, \frac{5}{6}\right)$$

9.  $(x, y, z) = (\frac{11}{4}, \frac{31}{4}, \frac{9}{2})$
10.  $(x, y, z) = (1, 0, -1)$
11.  $(x_1, x_2, x_3) = (\frac{51}{11}, \frac{17}{11}, \frac{45}{11})$
12.  $(x, y, z) = (-\frac{2}{3}, \frac{3}{4}, -\frac{1}{2})$
13.  $(x, y, z) = (1, 0, 2)$
14.  $(x, y, z, w) = (\frac{17}{7}, \frac{30}{7}, \frac{12}{7}, -\frac{24}{7})$

## 2.5 Solving Systems of Linear Equations, Continued (1 - 2 days)

In this section we consider three types of systems:

- (1) Those that have exactly one solution
- (2) Those that have no solution
- (3) Those that have an infinite number of solutions

One of the (many) advantages of the Gauss-Jordan form (the last stage of the iterated pivotal operations) is that it distinguishes at a glance among these three types as follows:

- (1) If every row has a "1" in a different (variable) column, all other entries being zero, there is exactly one solution. It is found in the "-1" column.
- (2) If the coefficients in a row are all zero, and the constant is not, there are no solutions. If the constant is also zero, delete that row and work with the others.
- (3) If there are more variable columns than rows (after deleting zero rows), and some rows have entries other than one "1" and zeros, the system has an infinite number



of solutions. The variables whose columns contain the non-zeros other than the "1", serve as parameter of the infinite solution set.

We have written solution sets in two ways. For instance the sets in Example 5 are

$$\{(x,y,z): x = -2s+3t+5, y = s, z = t, \text{ and } s,t \in \mathbb{R}\}$$

$$\text{or } \{(-2s + 3t + 5, s, t): s, t \in \mathbb{R}\}.$$

If you wish to write the solutions (not as yet) it may be done as follows:  $(x, y, z) = (-2s + 3t + 5, s, t)$ .

## 2.6 Exercise Solutions

1. 

x	y	-1
2	5	3
4	10	7
1	$\frac{5}{2}$	$\frac{3}{2}$
4	10	7
1	$\frac{5}{2}$	$\frac{3}{2}$
0	0	1

no solution.

2. 

x	y	-1
3	-2	3
6	-4	6
1	$-\frac{2}{3}$	1
6	-4	6
1	$-\frac{2}{3}$	1
0	0	0

$$\{(x,y): (1 + \frac{2}{3}t, t) \ t \in \mathbb{R}\}$$

$$\text{or } \{(1 + \frac{2}{3}t, t)\}.$$

3.

	x	y	z	-1
①	2	1	1	1
	2	1	0	3
	3	4	2	4
	1	2	3	1
	0	-3	-2	1
	0	-2	-1	1
	1	2	3	1
0	①	$\frac{2}{3}$	$\frac{1}{3}$	$-\frac{1}{3}$
0	-2	-1	1	1
	1	0	$\frac{1}{3}$	$\frac{5}{3}$
	0	1	$\frac{2}{3}$	$\frac{1}{3}$
	0	0	$\frac{1}{3}$	$\frac{1}{3}$
	1	0	$\frac{1}{3}$	$\frac{5}{3}$
	0	1	$\frac{2}{3}$	$\frac{1}{3}$
	0	0	①	1
	1	0	0	2
	0	1	0	-1
	0	0	1	1

$$(x, y, z) = (2, -1, 1).$$

$$\text{Check. } 2 + 2(-1) + 1 = 1$$

$$2(2) + (-1) = 3$$

$$3(2) + 4(-1) + 2(1) = 4.$$

4.

	x	y	z	-1
①	1	-2	1	1
	2	-1	1	1
	1	2	2	2
	1	1	-2	1
	0	-3	5	-1
	0	1	4	1
	1	1	-2	1
	0	-3	5	-1
	0	①	4	1
	1	0	-6	0
	0	1	4	1
	0	0	17	2
	1	0	-6	0
	0	1	4	1
	0	0	1	$\frac{2}{17}$
	1	0	0	$\frac{12}{17}$
	0	1	0	$\frac{9}{17}$
	0	0	1	$\frac{2}{17}$

$$(x, y, z) = \left(\frac{12}{17}, \frac{9}{17}, \frac{2}{17}\right).$$

$$\text{Check. } \frac{12}{17} + \frac{9}{17} - 2\left(\frac{2}{17}\right) = 1$$

$$2\left(\frac{12}{17}\right) - \left(\frac{9}{17}\right) + \frac{2}{17} = 1$$

$$\frac{12}{17} + 2\left(\frac{9}{17}\right) + 2\left(\frac{2}{17}\right) = 2.$$

5.

$x_1$	$x_2$	$x_3$	-1
2	1	2	4
2	2	1	7
0	1	-1	3
①	$\frac{1}{2}$	1	2
2	2	1	7
0	1	-1	3
1	$\frac{1}{2}$	1	2
0	①	-1	3
0	1	-1	3
1	0	$\frac{3}{2}$	$\frac{1}{2}$
0	1	-1	3
0	0	0	0

$\{(x_1, x_2, x_3): x_1 = \frac{1}{2} - \frac{3}{2}s,$   
 $x_2 = 3 + s, x_3 = s\}.$

6.

$x_1$	$x_2$	$x_3$	-1
2	1	3	-3
3	4	0	24
①	$\frac{1}{2}$	$\frac{3}{2}$	$-\frac{3}{2}$
3	4	0	24
1	$\frac{1}{2}$	$\frac{3}{2}$	$-\frac{3}{2}$
0	$\frac{5}{2}$	$-\frac{9}{2}$	$\frac{57}{2}$
1	$\frac{1}{2}$	$\frac{3}{2}$	$-\frac{3}{2}$
0	①	$-\frac{9}{5}$	$\frac{57}{5}$
1	0	$\frac{12}{5}$	$\frac{36}{5}$
0	1	$-\frac{9}{5}$	$\frac{57}{5}$

$\{(x_1, x_2, x_3): x_1 = -\frac{36}{5} - \frac{12}{5}t,$   
 $x_2 = \frac{57}{5} + \frac{9}{5}t, x_3 = t\}.$

7.

$x_1$	$x_2$	-1
①	1	5
2	-3	15
5	2	28
1	1	5
0	-5	5
0	-3	3
1	1	5
0	①	-1
0	-3	3
1	0	6
0	1	-1
0	0	0

$(x_1, x_2) = (6, -1)$

8.

$x$	$y$	-1
①	1	5
2	-3	15
3	-2	10
1	1	5
0	-5	5
0	-5	-5
1	1	5
0	①	-1
0	-5	-5
1	0	6
0	1	-1
0	0	-10

no solution

9.  $3r = 6 - s + 4t, \quad r = 2 - \frac{1}{3}s + \frac{4}{3}t. \quad \{(r,s,t): r = 6 - k + 4l, \\ s = k, r = l, k, l \in \mathbb{R}\}.$

10.  $2u - 7v = 4, \quad u = 2 + \frac{7}{2}v. \quad \{(u,v): u = 2 + \frac{7}{2}t, v = t, t \in \mathbb{R}\}.$

11.

a	b	c	-1
5	2	1	14
2	-1	-3	14
①	$\frac{2}{5}$	$\frac{1}{5}$	$\frac{14}{5}$
2	-1	-3	14
1	$\frac{2}{5}$	$\frac{1}{5}$	$\frac{14}{5}$
0	$-\frac{9}{5}$	$-\frac{17}{5}$	$\frac{42}{5}$
1	$\frac{2}{5}$	$\frac{1}{5}$	$\frac{14}{5}$
0	①	$\frac{17}{9}$	$-\frac{42}{9}$
1	0	$\frac{5}{9}$	$\frac{14}{3}$
0	1	$\frac{17}{9}$	$-\frac{42}{9}$

$\{(a,b): a = \frac{14}{3} + \frac{5}{9}k, \\ b = -\frac{14}{3} - \frac{17}{9}k, k \in \mathbb{R}\}.$

12.

x	z	-1
①	3	5
1	5	3
1	9	-1
1	3	5
0	2	-2
0	6	-6
1	3	5
0	①	-1
0	1	-1
1	0	8
0	1	-1
0	0	0

$(x,z) = (8, -1)$

Check.  $8 - 3 = 5, 8 - 5 = 3,$

$8 - 9 = -1.$

13.

x	y	z	-1
①	2	3	5
1	3	5	3
1	5	9	-1
1	2	3	5
0	①	2	-2
0	3	6	-6
1	0	-1	9
0	1	2	-2
0	0	0	0

$\{(x, y, z): x = 9 + t,$

$y = -2 - 2t, z = t\}.$

14.

x	y	z	-1
①	2	3	5
1	3	5	3
1	2	3	5
0	①	2	-2
1	0	-1	9
0	1	2	-2

$\{(x, y, z): x = 9 + t,$

$y = -2 - 2t, z = t\}.$

## 2.7 Homogeneous Linear Equations (1 day)

There are no new techniques introduced in this section. We devote a section to homogeneous linear equations because of their theoretic importance in subsequent studies. This becomes evident in differential equations (especially partial differential equations) vector subspaces (Chapter 8 Course III) are kernels of linear transformations (Course IV).

Of particular interest here is the fact that all systems of linear homogeneous equations have at least the solution  $(x_1, x_2, \dots, x_n) = (0, 0, \dots, 0)$ . Also, as system of  $m$  equations in  $n$  variables,  $m < n$ , has an infinite solution set. The Gauss-Jordan form helps to explain why this is so.

## 2.8 Exercise Solutions

1.  $(x, y) = (0, 0)$
2.  $(x, y) = (0, 0)$
3.  $(x, y) = (-3t, 2t)$   $t$  any real
4.  $(x, y) = (0, 0)$
5.  $\frac{a}{c} = \frac{b}{d}$  implies  $ad = bc$ , or  $ad - bc = 0$ .

$$\begin{array}{|c|c|} \hline x & y \\ \hline a & b \\ \hline c & d \\ \hline \end{array}
 \quad \text{is reducible to} \quad
 \begin{array}{|c|c|} \hline x & y \\ \hline 1 & -\frac{b}{a} \\ \hline 0 & \frac{ad - bc}{a} \\ \hline \end{array}
 \quad \text{or} \quad
 \begin{array}{|c|c|} \hline x & y \\ \hline 1 & -\frac{b}{a} \\ \hline 0 & 0 \\ \hline \end{array}$$

$$\therefore x = -\frac{b}{a}t, y = t. \quad t \text{ any real}$$

6.  $(x, y, z) = (0, 0, 0)$
7.  $(x_1, x_2, x_3) = (-4t, 3t, t)$   $t$  any real

8.  $(x, y, z) = (3t, 2t, -5t)$   $t$  any real  
9.  $(a, b, c) = (t, t, -t)$   $t$  any real  
10.  $(x_1, x_2, x_3) = (0, 0, 0)$   
11.  $(x_1, x_2, x_3, x_4) = (2t, 3t, -4t, -t)$   $t$  any real.

(Note: Infinite solution sets may be designated in other ways.)

12. The given system is equivalent to a system of two equations in three variables. By Gauss-Jordan reduction this leads to a form in which at most two columns have 1's. Thus one or two variables can be expressed in terms of the remaining variables. Hence an infinite number of solutions.

## 2.9 Matrix Multiplication Derived from Linear Equations in Matrix Notation (1 day)

We don't actually derive the definition of multiplication from a system of linear equations. We show that if we accept that definition the matrix notation for a system is equivalent to that system. This is further strengthened by showing how one matrix equation can represent a set of systems, having the same coefficient matrix.

The definition of matrix multiplication was discovered by Cayley, when he investigated the resultant of two linear transformations. We repeat his experience for simple transformations. Suppose under Transformation  $T_1$

$$\begin{aligned} x^1 &= a_{11}x + a_{12}y \\ y^1 &= a_{21}x + a_{22}y \end{aligned} \quad \left( M_1 = \begin{bmatrix} a_{11} & a_{12} \\ a_{21} & a_{22} \end{bmatrix} \right)$$

and under Transformation  $T_2$

$$\begin{aligned}x^{11} &= b_{11}x^1 + b_{12}y^1 \\y^{11} &= b_{21}x^1 + b_{22}y^{11}\end{aligned} \quad \left( M_2 = \begin{bmatrix} b_{11} & b_{12} \\ b_{21} & b_{22} \end{bmatrix} \right)$$

Then under  $T_2 \circ T_1$

$$x^{11} = b_{11}(a_{11}x + a_{12}y) + b_{12}(a_{21}x + a_{22}y)$$

$$y^{11} = b_{21}(a_{11}x + a_{12}y) + b_{22}(a_{21}x + a_{22}y)$$

$$x^{11} = (b_{11}a_{11} + b_{12}a_{21})x + (b_{11}a_{12} + b_{12}a_{22})y$$

$$y^{11} = (b_{21}a_{11} + b_{22}a_{21})x + (b_{21}a_{12} + b_{22}a_{22})y$$

This result is given by

$$M_2 \circ M_1 = \begin{bmatrix} b_{11}a_{11} + b_{12}a_{21} & b_{11}a_{12} + b_{12}a_{22} \\ b_{21}a_{11} + b_{22}a_{21} & b_{21}a_{12} + b_{22}a_{22} \end{bmatrix}$$

## 2.10 Exercise Solutions

1. (a)  $\begin{bmatrix} 3 & 5 \\ 1 & 2 \end{bmatrix} \begin{bmatrix} x \\ y \end{bmatrix} = \begin{bmatrix} 8 \\ 3 \end{bmatrix}$  or  $[x \ y] \begin{bmatrix} 3 & 1 \\ 5 & 2 \end{bmatrix} = [8 \ 3]$

(b)  $\begin{bmatrix} 3 & -5 \\ 1 & -3 \end{bmatrix} \begin{bmatrix} x \\ y \end{bmatrix} = \begin{bmatrix} 2 \\ 4 \end{bmatrix}$  or  $[x \ y] \begin{bmatrix} 3 & 1 \\ -5 & -3 \end{bmatrix} = [2 \ 4]$

(c)  $\begin{bmatrix} a & b \\ d & e \end{bmatrix} \begin{bmatrix} x \\ y \end{bmatrix} = \begin{bmatrix} c \\ f \end{bmatrix}$  or  $[x \ y] \begin{bmatrix} a & d \\ b & e \end{bmatrix} = [c \ b]$

2.  $\begin{bmatrix} 3 & 5 \\ 1 & 2 \end{bmatrix} \begin{bmatrix} x_1 & x_2 & x_3 \\ y_1 & y_2 & y_3 \end{bmatrix} = \begin{bmatrix} 8 & 3 & 1 \\ 3 & 1 & 0 \end{bmatrix}$

or  $\begin{bmatrix} x_1 & y_1 \\ x_2 & y_2 \\ x_3 & y_3 \end{bmatrix} \begin{bmatrix} 3 & 1 \\ 5 & 2 \end{bmatrix} = \begin{bmatrix} 8 & 3 \\ 3 & 1 \\ 1 & 0 \end{bmatrix}$

## 2.11 Matrix Inversion ( $1\frac{1}{2}$ - 2 days)

In Section 2.9 we used matrix notation to shed some light on systems of linear equations. In this section there is a reversal of point of view. We use a system of linear equation to solve an important problem about matrices. From our experiences with groups and fields, we know how important is the notion of inverses, both additive and multiplicative. Every matrix has an additive inverse. But every matrix does not have a multiplicative inverse. This perhaps unexpected fact is clarified with the aid of what we have learned about solving systems of linear equation.

Students should know that our concern here is only with square matrices. Others do not have inverses, for we cannot multiply two  $m \times n$  matrices if  $m \neq n$ .

## 2.12 Exercises Solutions

$$1. \left[ \begin{array}{cc|cc} 8 & 12 & 1 & 0 \\ 3 & 5 & 0 & 1 \end{array} \right] \text{ reduces to } \left[ \begin{array}{cc|cc} 1 & 0 & \frac{5}{4} & -3 \\ 0 & 1 & -\frac{3}{4} & 2 \end{array} \right]$$

$$\text{The inverse of } \left[ \begin{array}{cc} 8 & 12 \\ 3 & 5 \end{array} \right] \text{ is } \left[ \begin{array}{cc} \frac{5}{4} & -3 \\ -\frac{3}{4} & 2 \end{array} \right]$$

$$2. \left[ \begin{array}{cc|cc} 8 & 2 & 1 & 0 \\ 7 & 2 & 0 & 1 \end{array} \right] \text{ reduces to } \left[ \begin{array}{cc|cc} 1 & 0 & 1 & -1 \\ 0 & 1 & -\frac{1}{2} & 4 \end{array} \right]$$

$$\text{The inverse of } \left[ \begin{array}{cc} 8 & 2 \\ 7 & 2 \end{array} \right] \text{ is } \left[ \begin{array}{cc} 1 & -1 \\ -\frac{7}{2} & 4 \end{array} \right]$$



3.  $\begin{bmatrix} 8 & -4 \\ -2 & 1 \end{bmatrix}$  has no inverse.

4. No inverse.

5.  $\begin{bmatrix} \frac{1}{9} & \frac{2}{9} & \frac{4}{9} \\ \frac{2}{9} & \frac{4}{9} & \frac{1}{9} \\ \frac{4}{9} & \frac{1}{9} & \frac{2}{9} \end{bmatrix}$

6.  $\frac{1}{12} \begin{bmatrix} 6 & -3 & 3 \\ 8 & 2 & 14 \\ 2 & -1 & 5 \end{bmatrix}$

7.  $\begin{bmatrix} \frac{1}{a} & 0 & 0 \\ 0 & \frac{1}{b} & 0 \\ 0 & 0 & \frac{1}{c} \end{bmatrix}$

8.  $\begin{bmatrix} 1 & 0 & -1 \\ 5 & -1 & \frac{5}{2} \\ 5 & -1 & -2 \end{bmatrix}$

9. No inverse

10.  $\begin{bmatrix} 2 & \frac{1}{2} & \frac{1}{2} \\ 2 & \frac{3}{2} & \frac{1}{2} \\ 5 & \frac{7}{2} & \frac{3}{2} \end{bmatrix}$

11. No inverse

12.  $\begin{bmatrix} 0 & -1 & 0 & 1 \\ 1 & 1 & -1 & 0 \\ 1 & 1 & 0 & -1 \\ -1 & 0 & 1 & 0 \end{bmatrix}$

13. (a)  $X = \begin{bmatrix} 1 & 2 & -2 \\ -1 & 3 & 0 \\ 0 & -2 & 1 \end{bmatrix}$

(b)  $\begin{bmatrix} 1 & 2 & -2 \\ -1 & 3 & 0 \\ 0 & -2 & 1 \end{bmatrix} \cdot \begin{bmatrix} 3 & 2 & 6 \\ 1 & 1 & 2 \\ 2 & 2 & 5 \end{bmatrix} = \begin{bmatrix} 1 & 0 & 0 \\ 0 & 1 & 0 \\ 0 & 0 & 1 \end{bmatrix}$

### 2.13 Word Problems (2 - $2\frac{1}{2}$ days)

The aim of this section is to relate the solving of equations to problems that do not present themselves in the form of equations. It is assumed that students have already had some word problem experiences in earlier grades. We want here to extend these experiences to include systems of linear equations.

Many students find it difficult to solve word problems. Part of this difficulty arises often from their failure to appreciate the importance of finding and translating a word sentence into a mathematical sentence. Sometimes this is due to the fact that word sentences are implicit in the situation described in a problem. Often their search for that implicit sentence is a feeble one. Their efficiency can be much improved if they are (a) made aware that they are looking for a word sentence which expresses a number relation, and (b) willing to read the same sentence several times until they get an exact understanding of the number relation in the situation.

Some teachers believe that group word problems as types (coin, mixture, motion, etc.) does not bring home the main point that an equation or inequality corresponds to a word statement. Others believe it is easier to make this point only after students have had some experiences with a graded sequence of types of problems. We take no position on this

to search out the word statement that it is to be translated into mathematical symbols.

There are many situations we have not included in the exercises, feeling that doing so would make an already long chapter still longer. However, if you think you can make room for it we suggest that you compose problems that result in two equations in three unknowns, and some that result in three equations in two unknowns. You can still use situations like those we have described in our exercises, which involve stamps, coins, mixtures, gate receipts, etc.

The student is cautioned to check answers with the conditions as stated in the problem, not as described in equations or in equalities. Correct solutions of wrong equations will satisfy them, but not the conditions of the problem.

#### 2.14 Exercise Solutions

1. Let  $x$  be the number of single desks and  $y$  the number of double desks.

$$x + y = 36$$

$$x + 2y = 42 \qquad (x, y) = (30, 6)$$

2. Let  $x$  be the number of 4 cent stamps and  $y$  the number of 6 cent stamps.

$$x + y = 15$$

$$4x + 6y = 72 \qquad (x, y) = (9, 6)$$

3. Let  $x$  be the number of 4 cent stamps,  $y$  the number of 5 cent stamps, and  $z$  the number of 6 cent stamps.

$$x + y + z = 21$$

$$4x + 5y + 6z = 106$$

$$4x + 6y + 7z = 120 \quad (x, y, z) = (7, 6, 8)$$

4. Let  $x$  be the number of the 70 cent coffee,  $y$  the number of 80 cent coffee.

$$x + y = 20$$

$$70x + 80y = 76 \cdot 20 \quad (x, y) = (8, 12)$$

5. Let  $x$  be the number of dimes and  $y$  the number of quarters.

$$10x + 25y = 295$$

$$25x + 10y = 265 \quad (x, y) = (7, 9)$$

6. Let  $n$  be the number of nickels,  $d$  the number of dimes,  $q$  the number of quarters.

$$n + d + q = 13$$

$$5n + 10d + 25q = 240$$

$$5d + 10q + 25n = 145 \quad (n, d, q) = (2, 3, 8)$$

7. Let  $x$  be the number of junior members and  $y$  the number of all others.

$$x + y = 28$$

$$25x + 35y = 870 \quad (x, y) = (11, 17)$$

8. Let  $x_1$  be the number of A toys and  $x_2$  the number of B toys.

$$4x_1 + 6x_2 = 260$$

$$8x_1 + 5x_2 = 310$$

$$6x_1 + 3x_2 = 210 \quad (x_1, x_2) = (20, 30)$$

9.  $-2a + 3b = 7$

$$4a + 5b = 7$$

$$(a, b) = \left(-\frac{7}{11}, \frac{21}{11}\right)$$

10.  $a + 2b - 3c = 12$

$$a - 3b + 2c = 12$$

$$3a + b - 2c = 12$$

$$(a, b, c) = (0, -12, -12).$$

11. Let  $x$  be the number of men employed at 12 dollars,  $y$  the number at 15 dollars, and  $z$  the number at 20 dollars, per day.

$$x + y + z = 12$$

$$15x + 18y + 20z = 219$$

$$20x + 18y + 15z = 204 \quad (x, y, z) = (3, 3, 6)$$

12. Let  $m$  be the number of men,  $w$ , the number of women.

$$m = 2w$$

$$m - 5 = w + 5 \quad (m, w) = (20, 10)$$

13. Let  $m$  be the number of men;  $w$  the number of women;  $c$  the number of children

$$m + w + c = 46$$

$$m - 2 + w = c$$

$$w - (m - 2) = c - 12 \quad (m, w, c) = (8, 16, 22)$$

14  $4x - y + 2 = 0$

$$2x + y - 3 = 0$$

$$3x - y + 1 = 0 \quad \text{No solution. The ninny had no numbers in mind.}$$

15. Let the men's age be  $m$ , the women's  $w$ , the sons'  $s$ .

$$m + w + s = 64$$

$$m + 6 = 3(s + 6)$$

$$w - 4 = 12(s - 4) \quad (m, w, s) = (30, 28, 6).$$

16. Let the cost of first type be  $x$ ; second type  $y$ ; third type  $z$ .

$$x + y + z = 16$$

$$15,000x + 20,000y + 25,000z = 295,000$$

$$x = y + z \quad (x, y, z) = (8, 5, 3)$$

17.  $x + y + z = 16$

$$4x + 6y + 8z = 108$$

$$2x + 2y + 2z = 46$$

No solution. This implies contradictory data. If  $x + y + z = 16$ , then  $2x + 2y + 2z$  cannot equal 46.

2.16 Review Exercises Solutions (1 day)

1.  $x \quad y \quad -1$

1	-4	a
-1	3	b
1	-4	a
0	-1	a+b
1	0	-3a-4b
0	1	-a-b

$$(x, y) = (-3a-4b, -a-b)$$

2.  $x \quad y \quad z \quad -1$

1	3	2	1
1	2	2	3
3	7	5	6
1	3	2	1
0	-1	0	2
0	-2	-1	3
1	0	2	7
0	1	0	-2
0	0	-1	-1
1	0	2	5
0	1	0	-2
0	0	1	1

$$(x, y, z) = (5, -2, 1)$$

3.  $(x, y, z) = (-\frac{5}{4}, \frac{39}{4}, \frac{37}{4})$

4.  $(x, y) = (1, -1)$

5.  $(x, y, z) = (-\frac{1}{3} - t, t, \frac{7}{9} - \frac{1}{3}t) \quad t \in \mathbb{R}$

(There are other possible ways of writing these solutions.)

6.  $(x, y) = (\frac{8}{3} - \frac{2}{3}t, t)$  (or other ways of writing these solutions).

7.  $\begin{bmatrix} 5 & -2 \\ -7 & 3 \end{bmatrix}$

8.  $\begin{bmatrix} \frac{2}{5} & \frac{1}{5} \\ -\frac{1}{5} & \frac{3}{5} \end{bmatrix}$

9.  $\begin{bmatrix} \frac{1}{10} & \frac{13}{30} & -\frac{1}{30} \\ -\frac{1}{5} & \frac{2}{15} & \frac{1}{15} \\ \frac{1}{6} & -\frac{1}{18} & \frac{1}{18} \end{bmatrix}$

10.  $\begin{bmatrix} \frac{3}{7} & \frac{5}{7} & \frac{2}{7} \\ -\frac{6}{7} & \frac{3}{7} & \frac{4}{7} \\ \frac{2}{7} & -\frac{1}{7} & \frac{1}{7} \end{bmatrix}$

11.  $\begin{bmatrix} \frac{1}{3} & \frac{1}{3} & \frac{1}{3} & -\frac{2}{3} \\ \frac{1}{3} & \frac{1}{3} & -\frac{2}{3} & \frac{1}{3} \\ \frac{1}{3} & -\frac{2}{3} & \frac{1}{3} & \frac{1}{3} \\ -\frac{2}{3} & \frac{1}{3} & \frac{1}{3} & \frac{1}{3} \end{bmatrix}$

12.  $\begin{bmatrix} 3 & 2 \\ 7 & 5 \end{bmatrix} \begin{bmatrix} x_1 & x_2 & x_3 \\ y_1 & y_2 & y_3 \end{bmatrix} = \begin{bmatrix} 4 & 7 & 0 \\ 11 & 17 & 0 \end{bmatrix}$

$$\begin{bmatrix} 5 & -2 \\ -7 & 3 \end{bmatrix} \cdot \begin{bmatrix} 3 & 2 \\ 7 & 5 \end{bmatrix} \cdot \begin{bmatrix} x_1 & x_2 & x_3 \\ y_1 & y_2 & y_3 \end{bmatrix} = \begin{bmatrix} 5 & -2 \\ -7 & 3 \end{bmatrix} \begin{bmatrix} 4 & 7 & 0 \\ 11 & 17 & 0 \end{bmatrix}$$

$$\begin{bmatrix} x_1 & x_2 & x_3 \\ y_1 & y_2 & y_3 \end{bmatrix} = \begin{bmatrix} -2 & 1 & 0 \\ 5 & 2 & 0 \end{bmatrix}$$

$$(x_1, y_1) = (-2, 5), (x_2, y_2) = (1, 2), (x_3, y_3) = (0, 0).$$

13. The last equation is a linear combination of the other two, in fact their sum. Therefore the system consisting of the first two has the same solution set as the system consisting of the three. A system of two equations in three variables has an infinite number of solutions.

14.  $a + b + c = 0$

$$4a + 2b + c = 5 \quad (a, b, c) = \left(\frac{3}{2}, \frac{1}{2}, -2\right)$$

$$9a + 3b + c = 13$$

15. Let  $x$  be the number of packages of the first kind;  $y$  of the second kind.

$$4x + 3y = 38$$

$$3x + 5y = 45 \quad (x, y) = (5, 6)$$

16. Let  $x$  be the number of elementary school students,  $y$  the number of high school students,  $z$  the number of college students.

$$x + y + z = 100$$

$$25 + 50y + 100z = 6375$$

$$25x + 35y + 75z = 4850 \quad (x, y, z) = (75, 25, 40).$$

### An Interesting Application of Linearity

The following problem appears in Davis' The Mathematics of Matrices (p. 251). It might serve as the subject of an



interesting report or class discussion. It helps to explain the meaning of linearity as applied to a mechanical device. The essential mechanical principle is that a (movement) change in  $x$  (or  $y$ ) is accompanied by a change of  $k_1 x$  in the attached arm, and that changes in  $k_1 x$  and  $k_2 y$  of the left arms in the box produce a change of  $k_1 x + k_2 y$  in the output.

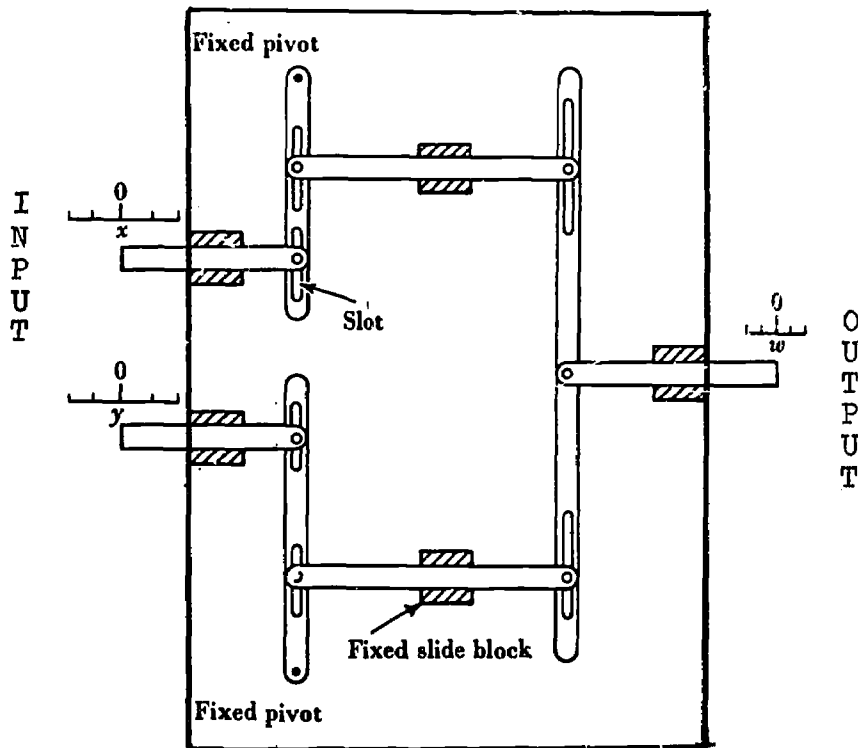

"Black Box" device

Figure A

Figure A depicts a "black box" device. Values of  $x$  and  $y$  (INPUT) are fed into the box and a result,  $w$  (OUTPUT), comes out. In this black box input values of  $x$  and  $y$  are determined by adjusting (pulling out or pushing in) the two levers  $x$  and  $y$ . The result can be read from the  $w$  (output) indicator.

The question is whether this device is linear--is the input  $(x, y)$  related to the output,  $w$ , by a linear relationship:

$$(x, y) \text{ -----} \rightarrow w = ax + by?$$

For example, if we had:

INPUT	OUTPUT
$(1,1)$ ----->	0
$(3,1)$ ----->	2
$(2,6)$ ----->	-4
$(6,2)$ ----->	4

you would suspect that you could write

$$(x,y) \text{ -----} \rightarrow w = x - y$$

$$(x,y) \text{ -----} \rightarrow w = 1x + -1y. \text{ Hence this input is}$$

related linearly to the output.

Determine whether the "black box" in Figure A is a linear device.

### Suggested Test Items and Answers

1. Using pivotal operations on a tableau solve each of the following systems. Use set notation to express infinite solution set.

$$(a) \quad \begin{cases} 3x + 2y = 5 \\ 5x + 4y = 7 \end{cases} \quad \text{Answer } (x, y) = (3, -2)$$

$$(b) \quad \begin{cases} x + 2y - z = 3 \\ x + 3y - 2z = 5 \\ 2x - y + z = -6 \end{cases} \quad \text{Answer } (x, y, z) = (-2, 3, 1)$$

(c) 
$$\begin{cases} x + 2y = 3 \\ x + 3y = 5 \\ 2x - y = 6 \end{cases}$$
 Answer: no solution

(d) 
$$\begin{cases} x - 2y + z = 0 \\ 2 - y - z = 0 \\ 3x + y - 2z = 0 \end{cases}$$

(e) 
$$\begin{aligned} x_1 + x_2 - 2x_3 &= 8 \\ 2x_1 - x_2 + 3x_3 &= 3 \\ 3x_1 + x_3 &= 11 \end{aligned}$$

Answer:  $\{(x_1, x_2, x_3) : x_1 = \frac{11}{3} - \frac{1}{3}t$

$x_2 = \frac{13}{3} + \frac{7}{3}t, x_3 = t, t \in \mathbb{R}\}.$

2. Find the inverse, if any, of 
$$\begin{bmatrix} 1 & 0 & -1 \\ -1 & 1 & 0 \\ 0 & -1 & 1 \end{bmatrix}$$

Answer: no inverse.

3. A dealer packages pens and pencils in only two ways. In one kind of package he puts 3 pens and 6 pencils. In the other he puts 5 pens and 2 pencils. Investigate whether or not it is possible to buy some packages of each kind to obtain a total of 50 pens and 50 pencils.

Answer: If  $x$  and  $y$  represent numbers of packages

$(x, y) = (\frac{25}{4}, \frac{25}{4})$  Impossible.

4. Buying 6 and 10 cent stamps, altogether 20 of them, I paid \$1.48. How many of each did I buy?

Answer: 13 6¢ stamps and 7 10¢ stamps.

### Chapter 3

#### THE ALGEBRA OF MATRICES

Time Estimate: 13 - 15 days

Below is a highly tentative schedule for covering Chapter 3. The first lessons may go much more quickly than here indicated - the latter ones may take more time. Depending on how Chapters 1 and 2 will have gone - the time limit on this chapter might be 2-4 weeks.

The suggested homework assignments for the first few lessons are proposed even more tentatively and hesitatingly than the lesson sequence. They are intended to hint at a spiral approach to the work - and at a stretching out of the problem materials beyond the time of the first considerations of a topic. In all instances, the simple and concrete exercises should be given first - the theoretical ones, the proofs - several days after the topic was first discussed.

<u>Lesson</u>	<u>Homework</u>
1. General Motivation Review occurrence of matrices Symbolism Equality	3.2 - 1, 3a, 4 Some problems from Chapters 1 and 2
2. Addition of Matrices Subtraction	3.2 - 2, 3b, 5 3.4 - 1a, 6a, 2 Some problems from Chapters 1 and 2
3. Review equality, add, subtract Go over homework problems	3.4 - 1b, 6b, 4a Some problems from Chapters 1 and 2

- |     |   |   |
|-----|---|---|
| 4.  | Multiplication by a scalar  | 3.4 - 1c, 4b, 6, c<br>3.6 - 1a, e; 2a, 4, 5a                            |
| 5.  | Continue with scalar multiplication   | 3.4 - 1d, 3, 6d<br>3.6 - 1b, 8; 2b, 3a, 5b                              |
| 6.  | Multiplication of matrices<br>Review Chapters 1 and 2<br>Theorems 6 and 7           | 3.8 - selection<br><br>Pick up from 3.4, 3.6<br>Some from Chapters 1, 2 |
| 7.  | Multiplication of matrices<br>Theorem 8   |   |
| 8.  | Review Sections 3.1-3.7   |   |
| 9.  | Multiplicative inverses   |   |
| 10. | Multiplicative inverses<br>Solution of equations<br>Review Chapter 2                |   |
| 11. | Complete Multiplicative Inverses  |   |
| 12. | Ring of $2 \times 2$ Matrices<br>Definition of Ring<br>Varieties of Rings<br>Fields |   |
| 13. | Various types of rings<br>Review homework problems                                  |   |
| 14. | A field of $2 \times 2$ Matrices  |   |
| 15. | Review Rings and Fields   |   |
| 16. | General Review  |   |
| 17. | Chapter Test  |   |

## Introduction

The primary aim of this chapter is to examine sets of matrices from a structural point of view. We want the students to examine the algebra of matrices as operational systems. They should attempt to determine which of the properties they have previously studied apply to matrices. This search for structural properties is not purely an academic exercise. A knowledge of these properties is the background against which we judge whether or not a problem involving matrices can be solved, and if so, how we might approach the solution.

In this search for group properties we shall find that a set of matrices having the same dimensions is an additive group, but a set of matrices that can be multiplied does not constitute a multiplicative group, even with the deletion of the additive identity. We shall find that a set of square matrices forms an operational system under multiplication, but not a group, resembling  $(\mathbb{Z}_4, \cdot)$  in this respect. But we shall find that a set of invertible (square) matrices of the same order, with the additive identity deleted, does form a multiplicative group.

After we study matrix addition and scalar multiplication we could introduce the very important concept of a vector space. However we have chosen to defer that study until it again arises naturally (and as it did in fact, historically) in connection with our study of vector geometry. At that point we will utilize certain subsets of matrices as additional illustrations of vector spaces. In this chapter subsets of  $2 \times 2$  matrices serve as illustrations of rings and fields. In 3.11 the ring of  $2 \times 2$  matrices is discussed. The ring structure will also appear

in Course III, Section 7.7 when polynomials are discussed. In 3.13 the field of special  $2 \times 2$  matrices is examined.

We have stressed matrices whose elements are real numbers. Another use for matrices is their relation to transformations which were described in terms of reals. However, the elements of matrices need not be real numbers, and it is advisable to give students some experiences with other fields, for instance, matrices whose elements are those of  $Z_3$ . Of course we should then add and multiply the elements of these matrices in accordance with the operation definitions of  $(Z_3, +, \cdot)$ . You may recall that we used matrices to describe bus routes among some towns, in which we used only whole numbers, another example where matrices did not use reals.

#### References

- Andree, Richard. Selections From Modern Abstract Algebra. New York: Henry Holt and Co., 1958.
- Davis, P. J. Mathematics of Matrices. New York: Interscience Publishers Inc., 1965.
- Eves, Howard. Elementary Matrix Theory. Boston: Allyn and Bacon Inc., 1966.
- Kelley, J. L. Algebra: A Modern Introduction. Princeton, N. J.: D. Van Nostrand Co., Inc., 1965.
- Kemeny, J., Snell, Thompson. Introduction to Finite Mathematics. Englewood Cliffs, N. J.: Prentice Hall Inc., 1965.
- Sawyer, W. W. A Concrete Approach to Abstract Algebra. San Francisco: W. H. Freeman Co., 1959.
- School Mathematics Study Group. Introduction to Matrix Algebra. Pasadena: A. C. Vroman Inc., 1965.

This chapter is heavily theoretical but, since it only formalizes the intuitive and notational uses of matrices from Chapters 1 and 2, it is easy to restate and summarize the theory rather quickly. However, you are urged to strike a balance between spending enough time on the theory to have its significance sink in - and spending too much time on theory. Do not wait until all the problems in any section have been done before you go on to the next section. Always save a few problems in any section for future uses in a good spiral review as you get into sections ahead. In fact - you should have problems left over from Chapters 1 and 2 to incorporate in the assignments of this chapter.

### 3.1 The World of Matrices (1 day)

The purpose of this section is stated in the students' text. We simply give a formal definition of an operation that has been performed and was motivated by real interpretations before. If the subscript notation gives difficulties - make up additional oral problems of the sort given in Examples 1 and 2 in Section 3.2.

The equality of matrices is defined - and the fact that it is an equivalence relation is left as an exercise.

Exercise 5 in Section 3.2 prepares the way for a formal definition in Section 3.3.



### 3.2 Exercise Solutions

1. a)  $4 \times 5$

b)  $5, 4, -7, -1, -1$

c)  $i = 1, j = 5$

$i = 2, j = 5$

$i = 4, j = 2$

$i = 4, j = 5$

2.  $a_{11} = 3 \cdot 1 - 2 \cdot 1 + 2 = 3$

$a_{21} = 3 \cdot 2 - 2 \cdot 1 + 2 = 6$

$a_{12} = 3 \cdot 1 - 2 \cdot 2 + 2 = 1$

$a_{22} = 3 \cdot 2 - 2 \cdot 2 + 2 = 4$

$a_{13} = 3 \cdot 1 - 2 \cdot 3 + 2 = -1$

$a_{23} = 3 \cdot 2 - 2 \cdot 3 + 2 = 2$

$$\begin{bmatrix} a_{11} & a_{12} & a_{13} \\ a_{21} & a_{22} & a_{23} \end{bmatrix} = \begin{bmatrix} 3 & 1 & -1 \\ 6 & 4 & 2 \end{bmatrix}$$

3. a)  $x + 3 = 1$

$x = -2$

$2 - y = 3$

$y = -1$

b)  $x^2 = 1$                        $y = -1$

$x = -1$                        $y^2 = 1$

$x = -1$                        $y = -1$                        $(x, y) = (-1, -1)$

5. a) By definition two matrices are equal iff they have the same dimension and corresponding entries are equal. Since, for all  $A$ ,  $a_{ij} = a_{ij}$ , then  $A = A$ .

b) If  $A = B$ , then  $a_{ij} = b_{ij}$ , for all  $i, j$ . By the symmetry property for real numbers, if  $a_{ij} = b_{ij}$ , then  $b_{ij} = a_{ij}$ . Hence  $B = A$ .

- c) If  $A = B$  and  $B = C$ , then  $a_{ij} = b_{ij}$  and  $b_{ij} = c_{ij}$  for all  $i, j$ . By the transitive property for real numbers,  $a_{ij} = b_{ij} = c_{ij}$ . Hence  $A = C$ .

4. 
$$\begin{bmatrix} \underline{1} & 1 & \underline{0} \\ 1 & 1 & 1 \\ 1 & -1 & 1 \\ \underline{2} & 0 & \underline{1} \end{bmatrix}$$

### 3.3 Addition of Matrices (1 - 1 $\frac{1}{2}$ days)

Students should be made aware of the fact that addition of matrices is defined only for matrices that have the same dimensions, and that addition of corresponding elements is performed as defined in the system from which the elements are taken. Thus, for instance,  $2 + 1 = 0$  if the elements of the matrix are taken from  $Z_3$ . Some books describe matrices that can be added as "conformable for addition" or "addition conformable". We have not used these terms in the text, but your students may find them convenient in their discussions.

The highlight of this section is the theorem that  $(M, +)$  is a group, where  $M$  is a set of matrices having the same dimensions. This is one of the properties of a vector space. The additive inverse group property makes possible the inverse operation of subtraction.

Equality between two matrices was defined only for two matrices that have the same dimensions. This implies that for each entry in one matrix there is an equal corresponding entry

in the other. This equality relation is an equivalence relation, and hence any member of a set of equal matrices may be used to name the set.

The notion of equality between matrices makes possible writing as many scalar equations as there are entries in each matrix. This lies behind a number of exercises in the section that follows.

### 3.4 Exercise Solutions

1. a)  $\begin{bmatrix} \bar{3} & 4 & \bar{3} \\ \underline{3} & 0 & \underline{3} \end{bmatrix}$

b) Cannot be added

c)  $\begin{bmatrix} \bar{a} & b & \bar{c} \\ \underline{d} & e & \underline{f} \end{bmatrix}$

d)  $\begin{bmatrix} \bar{0} & \bar{0} \\ \underline{0} & \underline{0} \end{bmatrix}$

2. a)  $\begin{bmatrix} \bar{1} & -1 & \bar{0} \\ \underline{5-\sqrt{2}} & -10 & \underline{2} \end{bmatrix}$

b) Cannot be subtracted

3. a) By definition  $(-A)$  is the matrix such that  $A + (-A) = \bar{0}$ . Thus  $(-A)$  has elements  $-a_{ij}$ .

Since  $a_{ij} = -(-a_{ij})$  it follows that  $A = -(-A)$ .

b) By (a),  $-(A + B)$  has elements  $-a_{ij} - b_{ij} = (-a_{ij}) + (-b_{ij})$ .

$$\therefore -(A + B) = (-A) + (-B).$$

c)  $-\bar{0} = \bar{0}$  since  $\bar{0} + (-\bar{0}) = \bar{0}$ .

4. a)  $a - 2 = 3, 2b + 1 = -5, a + 3 = c, 16 = 3d - 2$

$$\therefore a = 5, b = -3, c = 8, d = 6$$

b)  $3a = 15, 10 = 2b, 2a + c = 10, 2b - d = 0.$

$$\therefore a = 5, b = 5, c = 0, d = 10$$

5. a) Since  $a_{ij} + b_{ij} = b_{ij} + a_{ij}$ ,  $A + B = B + A$ .  
 b) Since  $(a_{ij} + b_{ij}) + c_{ij} = a_{ij} + (b_{ij} + c_{ij})$ ,  
 $(A + B) + C = A + (B + C)$ .  
 c) Since  $a_{ij} + 0 = 0 + a_{ij} = a_{ij}$ ,  $A + \bar{0} = \bar{0} + A = A$ .  
 d) If  $b_{ij} = -a_{ij}$ , then  $a_{ij} + b_{ij} = b_{ij} + a_{ij} = 0$ , and  
 $A + B = B + A = \bar{0}$ . (The uniqueness of B follows  
 from the uniqueness of  $b_{ij}$ ).

6. a) 
$$\begin{bmatrix} 2 & 10 \\ 3 & 21 \\ 3 & 14 \\ 8 & 45 \end{bmatrix}$$

b) 
$$\begin{bmatrix} 1 & 2 & 0 \\ 2 & & \\ -8 & 10 & 0 \\ 3 & 3 & \end{bmatrix}$$

c) 
$$\begin{bmatrix} a + 1 & b & c \\ d & e + 1 & f \\ g & h + 1 & i + 1 \end{bmatrix}$$

d) 
$$\begin{bmatrix} a & b \\ 4a + b & 2a \end{bmatrix}$$

### 3.5 Multiplication of a Matrix by a Scalar (1 - 2 days)

Note in the definition of  $k \cdot A$ , where  $k$  is a scalar and  $A$  is a matrix,  $k$  is always written first. Perhaps your students will ask whether  $A \cdot k$  means the same as  $k \cdot A$ . This is a natural question since we have been interested on many occasions whether multiplication over a set of numbers is commutative. In some books  $k \cdot A$  and  $A \cdot k$  are defined to be equal. However we prefer to talk only about  $k \cdot A$  for a reason that may elude, and perhaps confuse them. We therefore leave it for you to decide whether or not to answer the question. If you decide to answer the explanation might be offered as follows:

We must first recognize that  $k$  and  $A$  are members of

different sets. In this respect alone we note immediately that we do not have multiplication in the ordinary sense. Then we must recognize that  $k \cdot A$  is never a scalar; it is always a matrix. The two observations should convince us that we do not have an operation in the sense that multiplication over the set of reals is an operation. It is unfortunate then that we use the term "multiplication" in the title of this section.

Operations over the set of reals - in which pairs of numbers are mapped onto the set of reals are what are sometimes called "internal operations" (Bourbaki). Multiplication of a matrix by a scalar is an example of an "external" operation.

However we do recognize that an assignment is made to every ordered pair consisting of a scalar and a matrix. The notion of an assignment belongs to a mapping also. And we actually have here a mapping, whose domain and range is a set of matrices. To follow through on this analysis we call  $k$  the mapping and the rule of the mapping is to multiply each number of the matrix by the number  $k$ . Hence  $k$  is used to mean both a mapping and the number used in the rule of the mapping. This explains why we do not write  $A \cdot k$ , for our notation calls for writing mapping first, then the object to be mapped. It also explains why the word multiplication is used. It is hoped that the two meanings given to  $k$  in  $k \cdot A$  will be clearly differentiated.

It is in this connection that we say "closure makes no sense" here. Not too much should be made of this because by virtue of our definitions we still have a sort extension on

the notion of closure. We insist that  $R \cdot A$  must be in the set of matrices.

Incidentally, if  $\mathcal{M}$  is a set of matrices having the same dimensions and  $A$  is a fixed member of  $\mathcal{M}$ , then  $\{k \cdot A, k \in R\}$  is a module, for it is a subset of an additive group, and is itself an additive group.

### 3.6 Exercise Solutions

Note: Exercises that have a number of parts, as 1, 2, 3, 5 - should not be assigned all at once at any one time. Use them sparingly - assign two or three at a given time and save the other parts for review aspects later on - possibly even in future chapters.

1. a)  $\begin{bmatrix} 6 & -2 & 0 \\ 8 & 4 & 2\sqrt{3} \end{bmatrix}$

b)  $\begin{bmatrix} 9 & -3 & 0 \\ 12 & 6 & 3\sqrt{3} \end{bmatrix}$

c)  $\begin{bmatrix} -6 & 2 & 0 \\ -8 & -4 & -2\sqrt{3} \end{bmatrix}$

d)  $\begin{bmatrix} 0 & 0 & 0 \\ 0 & 0 & 0 \end{bmatrix}$

e)  $\begin{bmatrix} 3\sqrt{3} & -\sqrt{3} & 0 \\ 4\sqrt{3} & 2\sqrt{3} & 3 \end{bmatrix}$

f)  $\begin{bmatrix} 6+3\sqrt{3} & -2-\sqrt{3} & 0 \\ 8+4\sqrt{3} & 4+2\sqrt{3} & 2\sqrt{3}+3 \end{bmatrix}$

g)  $\begin{bmatrix} 1 & -\frac{1}{3} & 0 \\ \frac{4}{3} & \frac{2}{3} & \frac{\sqrt{3}}{3} \end{bmatrix}$

h)  $\begin{bmatrix} .6 & -.2 & 0 \\ .8 & .4 & .2\sqrt{3} \end{bmatrix}$

2. a)  $2A + B - C = \begin{bmatrix} 6 & 4 \\ 10 & 2 \end{bmatrix} + \begin{bmatrix} -3 & 4 \\ 0 & -4 \end{bmatrix} - \begin{bmatrix} 2 & 0 \\ 0 & 5 \end{bmatrix} = \begin{bmatrix} 1 & 8 \\ 10 & -7 \end{bmatrix}$

b)  $3A + 2B - 4C = \begin{bmatrix} 9 & 6 \\ 15 & 3 \end{bmatrix} + \begin{bmatrix} -6 & 8 \\ 0 & -8 \end{bmatrix} - \begin{bmatrix} 8 & 0 \\ 0 & 20 \end{bmatrix} = \begin{bmatrix} -5 & 14 \\ 15 & -25 \end{bmatrix}$

$$c) 2(A + 2C) - 3C = \begin{bmatrix} 6 & 4 \\ 10 & 2 \end{bmatrix} + \begin{bmatrix} -12 & 16 \\ 0 & -16 \end{bmatrix} - \begin{bmatrix} 6 & 0 \\ 0 & 15 \end{bmatrix} = \begin{bmatrix} -12 & 20 \\ 10 & -29 \end{bmatrix}$$

$$d) \sqrt{2}(A + B + C) = \sqrt{2} \begin{bmatrix} 2 & 6 \\ 5 & 2 \end{bmatrix} = \begin{bmatrix} 2\sqrt{2} & 6\sqrt{2} \\ 5\sqrt{2} & 2\sqrt{2} \end{bmatrix} - \begin{bmatrix} 3 & 2 \\ 5 & 1 \end{bmatrix} =$$

$$\begin{bmatrix} 2\sqrt{2} - 3 & 6\sqrt{2} - 2 \\ 5\sqrt{2} - 5 & 2\sqrt{2} - 1 \end{bmatrix}$$

$$3. a) A + B + C = \begin{bmatrix} 1 & 1 & 1 \\ 1 & 2 & 0 \\ 1 & 0 & 2 \end{bmatrix}$$

$$b) A + B - C = \begin{bmatrix} -1 & 1 & 1 \\ 1 & 0 & 0 \\ 1 & 0 & 0 \end{bmatrix}$$

$$c) A - (B + C) = \begin{bmatrix} -1 & -1 & 1 \\ -1 & 0 & 0 \\ 1 & 0 & -2 \end{bmatrix}$$

$$d) 2A + 3B + 4C = \begin{bmatrix} 0 & 0 & 2 \\ 0 & 2 & 0 \\ 2 & 0 & 0 \end{bmatrix} + \begin{bmatrix} 0 & 3 & 0 \\ 3 & 0 & 0 \\ 0 & 0 & 3 \end{bmatrix} + \begin{bmatrix} 4 & 0 & 0 \\ 0 & 4 & 0 \\ 0 & 0 & 4 \end{bmatrix} =$$

$$\begin{bmatrix} 4 & 3 & 2 \\ 3 & 6 & 0 \\ 2 & 0 & 7 \end{bmatrix}$$

$$e) 3(A - B) + 2C = \begin{bmatrix} 0 & -3 & 3 \\ -3 & 3 & 0 \\ 3 & 0 & -3 \end{bmatrix} + \begin{bmatrix} 2 & 0 & 0 \\ 0 & 2 & 0 \\ 0 & 0 & 2 \end{bmatrix} = \begin{bmatrix} 2 & -3 & 3 \\ -3 & 5 & 0 \\ 3 & 0 & 1 \end{bmatrix}$$

4. a) \_\_\_\_\_

$$b) \begin{bmatrix} 3 & -2 \\ 0 & 2 \end{bmatrix} = 3 \begin{bmatrix} 1 & 0 \\ 0 & 0 \end{bmatrix} + 2 \begin{bmatrix} 0 & 1 \\ 0 & 0 \end{bmatrix} + 0 \begin{bmatrix} 0 & 0 \\ 1 & 0 \end{bmatrix} + 2 \begin{bmatrix} 0 & 0 \\ 0 & 1 \end{bmatrix}.$$

$$c) \begin{bmatrix} a & b & c \\ d & e & f \end{bmatrix} = a \begin{bmatrix} 1 & 0 & 0 \\ 0 & 0 & 0 \end{bmatrix} + b \begin{bmatrix} 0 & 1 & 0 \\ 0 & 0 & 0 \end{bmatrix} + c \begin{bmatrix} 0 & 0 & 1 \\ 0 & 0 & 0 \end{bmatrix} \\ + d \begin{bmatrix} 0 & 0 & 0 \\ 1 & 0 & 0 \end{bmatrix} + e \begin{bmatrix} 0 & 0 & 0 \\ 0 & 1 & 0 \end{bmatrix} + f \begin{bmatrix} 0 & 0 & 0 \\ 0 & 0 & 1 \end{bmatrix} .$$

$$5. a) \begin{bmatrix} 3 & 2 \\ 5 & 1 \end{bmatrix} + X = \begin{bmatrix} -3 & 4 \\ 0 & -4 \end{bmatrix} + \begin{bmatrix} 2 & 0 \\ 0 & 5 \end{bmatrix}, X = \begin{bmatrix} -4 & 2 \\ -5 & 0 \end{bmatrix}$$

$$b) \begin{bmatrix} 3 & 2 \\ 5 & 1 \end{bmatrix} + 2X = \begin{bmatrix} -3 & 4 \\ 0 & -4 \end{bmatrix} - \begin{bmatrix} 2 & 0 \\ 0 & 5 \end{bmatrix}, 2X = \begin{bmatrix} -8 & 2 \\ -5 & -10 \end{bmatrix}, X = \\ \begin{bmatrix} -4 & 1 \\ -\frac{5}{2} & -5 \end{bmatrix}$$

$$c) \frac{1}{2} \left( \begin{bmatrix} 3 & 2 \\ 5 & 1 \end{bmatrix} + X \right) = 3X + 2 \begin{bmatrix} -3 & 4 \\ 0 & -4 \end{bmatrix}$$

$$\begin{bmatrix} 3 & 2 \\ 5 & 1 \end{bmatrix} + X = 6X + 4 \begin{bmatrix} -3 & 4 \\ 0 & -4 \end{bmatrix}$$

$$\begin{bmatrix} 3 & 2 \\ 5 & 1 \end{bmatrix} - \begin{bmatrix} -12 & 16 \\ 0 & -16 \end{bmatrix} = 5X$$

$$\begin{bmatrix} 15 & -14 \\ 5 & 17 \end{bmatrix} = 5X, X = \begin{bmatrix} 3 & -\frac{14}{5} \\ 1 & \frac{17}{5} \end{bmatrix}$$

$$d) 3 \left( \begin{bmatrix} -3 & 4 \\ 0 & -4 \end{bmatrix} - X \right) = 2 \left( X - \begin{bmatrix} 2 & 0 \\ 0 & 5 \end{bmatrix} \right) - \begin{bmatrix} -3 & 4 \\ 0 & -4 \end{bmatrix}$$

$$\begin{bmatrix} -9 & 12 \\ 0 & -12 \end{bmatrix} - 3X = 2X - \begin{bmatrix} 4 & 0 \\ 0 & 10 \end{bmatrix} - \begin{bmatrix} -3 & 4 \\ 0 & -4 \end{bmatrix}$$

$$\begin{bmatrix} -8 & 16 \\ 0 & -6 \end{bmatrix} = 5X, X = \begin{bmatrix} -\frac{8}{5} & \frac{16}{5} \\ 0 & -\frac{6}{5} \end{bmatrix}$$

$$6. a) (k + l)(a_{ij}) = ka_{ij} + la_{ij}. \text{ Therefore } (k + l)A \\ = kA + lA.$$



b)  $(kl)(a_{ij}) = k(la_{ij})$ . Therefore  $(kl)A = k(la)$ .

c) If  $k = 0$ ,  $k(a_{ij}) = 0$ .  $\therefore kA = \bar{0}$ .

If  $A = 0$ ,  $a_{ij} = 0$ , and  $k(a_{ij}) = 0$ .  $\therefore kA = \bar{0}$ .

If  $kA = \bar{0}$  then for all  $i, j$ ,  $k \cdot a_{ij} = 0$ .

Then in turn if  $k = 0$  or  $a_{ij} = 0$ . If  $a_{ij} = 0$  then

$A = \bar{0}$ .

d) For all  $i, j$ ,  $1 \cdot a_{ij} = a_{ij}$ .  $\therefore 1A = A$ .

e)  $kA = kB$  implies  $ka_{ij} = kb_{ij}$ . Since  $k \neq 0$ ,  $a_{ij} = b_{ij}$ . Hence  $A = B$ .

7. Since  $k \in R$ ,  $-k \in R$ . For each matrix in  $\{kA\}$  there is a matrix  $-kA$ . Since  $kA + (-k)A = (-k)A + kA = \bar{0}$ ,  $-kA$  is the additive inverse of  $kA$ .

8. a)  $Z_3 = \{0, 1, 2\}$ . Hence each entry can be one of three numbers. The total number matrices in  $P$  is therefore  $3 \cdot 3 \cdot 3 \cdot 3 = 81$ .

b)  $(P, +)$  is a group for

(i) The sum of any two matrices in  $P$  is in  $P$  since  $Z_3$  is a group under addition.

(ii) For any three matrices in  $P$ ,  $A + (B + C) = (A + B) + C$ , since addition in  $Z_3$  is associative.

(iii) The matrix  $\begin{bmatrix} 0 & 0 \\ 0 & 0 \end{bmatrix}$  is the additive identity.

(iv) For each matrix in  $P$  there is an additive inverse since for each number in  $Z_3$  there is an additive inverse. For instance, the

additive inverse of  $\begin{bmatrix} 0 & 1 \\ 2 & 1 \end{bmatrix}$  is  $\begin{bmatrix} 0 & -1 \\ -2 & -1 \end{bmatrix}$ .

$$c) \quad 0A = \begin{bmatrix} 0 & 0 \\ 0 & 0 \end{bmatrix}, \quad 1A = \begin{bmatrix} 1 & 2 \\ 0 & 1 \end{bmatrix}, \quad 2A = \begin{bmatrix} 2 & 1 \\ 0 & 2 \end{bmatrix}.$$

The set  $\{kA\}$  is a group.

The table

+	0A	1A	2A
0A	0A	1A	2A
1A	1A	2A	0A
2A	2A	0A	1A

can be used to facilitate the presentation of the proof.

$$d) \quad 0B = \begin{bmatrix} 0 & 0 \\ 0 & 0 \end{bmatrix}, \quad 1B = \begin{bmatrix} 1 & 1 \\ 1 & 1 \end{bmatrix}, \quad 2B = \begin{bmatrix} 2 & 2 \\ 2 & 2 \end{bmatrix}.$$

$\{kB\}$  is a group under addition. A Cayley table (as in c)) facilitates the presentation of the proof.

$$\{kA\} \cap \{kB\} = \begin{bmatrix} 0 & 0 \\ 0 & 0 \end{bmatrix}.$$

e) If C, D, E are the given matrices, then the table

	E	D	C
E	E	D	C
D	D	C	E
C	C	E	D

is the group table.

$$f) \quad X + \begin{bmatrix} 1 & 1 \\ 1 & 0 \end{bmatrix} = 2 \left( X + \begin{bmatrix} 1 & 2 \\ 1 & 0 \end{bmatrix} \right), \quad X + \begin{bmatrix} 1 & 1 \\ 1 & 0 \end{bmatrix} \\ = 2X + \begin{bmatrix} 2 & 4 \\ 2 & 0 \end{bmatrix}, \quad X = \begin{bmatrix} -1 & -3 \\ -1 & 0 \end{bmatrix}.$$

9. Let  $A = \begin{bmatrix} 1 & 1 \\ 2 & 3 \end{bmatrix}$ . Then  $\{0A, 1A, 2A, 3A\}$  do form a group under addition.

Let  $A = \begin{bmatrix} 2 & 2 \\ 2 & 2 \end{bmatrix}$ . Then  $\{0A, 1A\}$  form a group.  $\begin{bmatrix} 0 & 0 \\ 0 & 0 \end{bmatrix}$

is also a group. The answer is: yes.

### 3.7 Multiplication of Matrices ( $1\frac{1}{2}$ - 2 days)

In this section we formalize the definition of the multiplication of matrices. If your students have difficulty - in the first stages - with the procedure "multiply row by column" - you might try a pictorial device that Papy uses in his Modern Mathematics 6 Chapter 6. With the use of colors he shows:

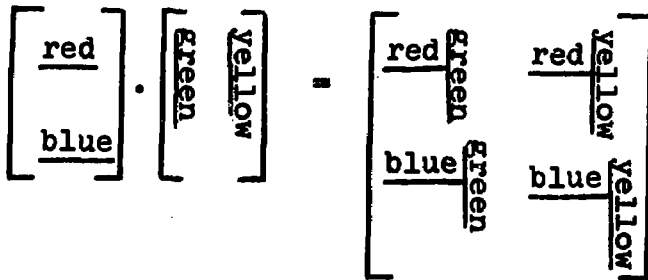

This can also be shown by:

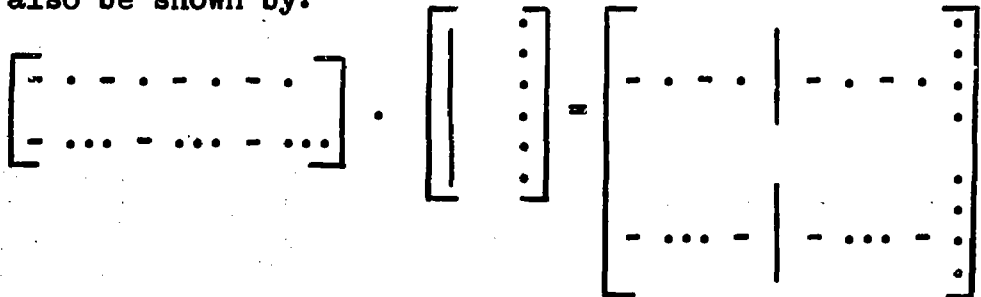

It will help your students if they understand clearly that two matrices can be multiplied only if the first matrix has as many columns as the second has rows, and that the product has

as many rows as the first and as many columns as the second. They may find the following mnemonic helpful.

$$[i, j] \cdot [j, k] = [i, k].$$

Note, in passing, that if the order of the matrices indicated in this mnemonic is reversed, we no longer have the required condition satisfied. It becomes immediately apparent that it is idle to ask whether the multiplication of matrices is commutative, because we do not even have a product in the second case.

However, if  $i = j = k$ , that is, if the two matrices are square matrices of the same order, then a reversal of order results in a possible multiplication. Hence, for square matrices of the same order, the question of commutativity of multiplication is a meaningful one.

Since multiplicative inverses are defined  $A \cdot B = B \cdot A = I$ , the question of the invertibility of a matrix applies only to square matrices, and  $I$ , the unit matrix, is necessarily a square matrix.

Moreover, when we investigate whether a set of matrices is a multiplicative group we need concern ourselves with a set of square matrices having the same order. Limited to such sets multiplication is indeed an operation since the product of any two of its members is a member of the set since the product has the same order as that of its factors.

Most of our attention in this section is devoted to  $\mathcal{M}_2$ , the set of matrices of order 2. We see that  $(\mathcal{M}_2, \cdot)$  is not a group because not all its members have multiplicative inverses.

In this respect  $(\mathcal{M}_2, \cdot)$  resembles  $(Z_6, \cdot)$ , in which neither 2 nor 3 have inverses since there is no number in  $Z_6$  for which  $2x = 1$  or for which  $3x = 1$ . But  $(\mathcal{M}_2, \cdot)$  like  $(Z_6, \cdot)$  enjoys the associative property, and they differ in that  $\cdot$  is not commutative in  $(\mathcal{M}_2, \cdot)$  but  $\cdot$  is commutative in  $(Z_6, \cdot)$ . However the set of invertible matrices in  $\mathcal{M}_2$  do form a (non-commutative) multiplicative group, as we see in Section 3.11, Theorem 14.

### 3.8 Exercise Solution

$$1. \quad a) \quad AB = \begin{bmatrix} 0 & 1 \\ 1 & 0 \end{bmatrix} \cdot \begin{bmatrix} 0 & -1 \\ 1 & 0 \end{bmatrix} = \begin{bmatrix} 1 & 0 \\ 0 & -1 \end{bmatrix}$$

$$b) \quad AC = \begin{bmatrix} 0 & 1 \\ 1 & 0 \end{bmatrix} \cdot \begin{bmatrix} 1 & 0 \\ 0 & -1 \end{bmatrix} = \begin{bmatrix} 0 & -1 \\ 1 & 0 \end{bmatrix}$$

$$c) \quad BC = \begin{bmatrix} 0 & -1 \\ 1 & 0 \end{bmatrix} \cdot \begin{bmatrix} 1 & 0 \\ 0 & -1 \end{bmatrix} = \begin{bmatrix} 0 & 1 \\ 1 & 0 \end{bmatrix}$$

$$d) \quad BA = \begin{bmatrix} 0 & -1 \\ 1 & 0 \end{bmatrix} \cdot \begin{bmatrix} 0 & 1 \\ 1 & 0 \end{bmatrix} = \begin{bmatrix} -1 & 0 \\ 0 & 1 \end{bmatrix}$$

$$e) \quad CA = \begin{bmatrix} 1 & 0 \\ 0 & -1 \end{bmatrix} \cdot \begin{bmatrix} 0 & 1 \\ 1 & 0 \end{bmatrix} = \begin{bmatrix} 0 & 1 \\ -1 & 0 \end{bmatrix}$$

$$f) \quad CB = \begin{bmatrix} 1 & 0 \\ 0 & -1 \end{bmatrix} \cdot \begin{bmatrix} 0 & -1 \\ 1 & 0 \end{bmatrix} = \begin{bmatrix} 0 & -1 \\ -1 & 0 \end{bmatrix}$$

2.  $AB = -BA$ ;  $AC = -CA$ ;  $BC = -CB$ . For any two matrices D and E in  $M_2$ , it is not true that  $DE = -ED$ . For instance

$$\begin{bmatrix} 1 & 2 \\ 0 & 1 \end{bmatrix} \cdot \begin{bmatrix} 3 & 1 \\ 4 & 2 \end{bmatrix} = \begin{bmatrix} 11 & 5 \\ 4 & 2 \end{bmatrix} \quad \text{but} \quad \begin{bmatrix} 3 & 1 \\ 4 & 2 \end{bmatrix} \cdot \begin{bmatrix} 1 & 2 \\ 0 & 1 \end{bmatrix} = \begin{bmatrix} 3 & 7 \\ 4 & 10 \end{bmatrix}$$

$$3. \quad A^2 = \begin{bmatrix} -2 & 3 \\ 2 & 1 \end{bmatrix} \cdot \begin{bmatrix} -2 & 3 \\ 2 & 1 \end{bmatrix} = \begin{bmatrix} 10 & -3 \\ -2 & 7 \end{bmatrix}$$

$$A^3 = A \cdot (A \cdot A) = \begin{bmatrix} -2 & 3 \\ 2 & 1 \end{bmatrix} \cdot \begin{bmatrix} 10 & -3 \\ -2 & 7 \end{bmatrix} = \begin{bmatrix} -26 & 27 \\ 18 & 1 \end{bmatrix}$$

$$\text{or } A^3 = (A \cdot A) \cdot A = \begin{bmatrix} 10 & -3 \\ -2 & 7 \end{bmatrix} \cdot \begin{bmatrix} -2 & 3 \\ 2 & 1 \end{bmatrix} = \begin{bmatrix} -26 & 27 \\ 18 & 1 \end{bmatrix}$$

4. If there is a multiplicative inverse let it be  $\begin{bmatrix} x & y \\ z & w \end{bmatrix}$ .

$$\text{Then } \begin{bmatrix} a & a \\ b & b \end{bmatrix} \cdot \begin{bmatrix} x & y \\ z & w \end{bmatrix} = \begin{bmatrix} ax + az & ay + aw \\ bx + bz & by + bw \end{bmatrix} = \begin{bmatrix} 1 & 0 \\ 0 & 1 \end{bmatrix}$$

$$(1) \quad ax + az = 1 \qquad (2) \quad ay + aw = 0$$

$$(3) \quad bx + bz = 0 \qquad (4) \quad by + bw = 1$$

From (1) and (3),  $a(x + z) = 1$  and  $b(x + z) = 0$ . Since  $x + z \neq 0$ , then  $b = 0$ . But (4) says that  $b(y + w) = 1$ .

Hence  $b \neq 0$ . Therefore,  $\begin{bmatrix} a & a \\ b & b \end{bmatrix}$  has no multiplicative inverse.

5. a) true    b) false ( $AC \neq CA$ )    c) false    d) false

$$6. \quad a) \quad EF = \begin{bmatrix} a & b \\ -b & a \end{bmatrix} \cdot \begin{bmatrix} c & d \\ -d & c \end{bmatrix} = \begin{bmatrix} ac - bd & ad + bc \\ -bc - ad & -bd + ac \end{bmatrix}$$

$$FE = \begin{bmatrix} c & d \\ -d & c \end{bmatrix} \cdot \begin{bmatrix} a & b \\ -b & a \end{bmatrix} = \begin{bmatrix} ac - bd & bc + ad \\ -ad - bc & -bd + ac \end{bmatrix}$$

$\therefore EF = FE$ .

b) In  $g = E \cdot F$ ,  $g_{11} = g_{22}$  and  $g_{12} = -g_{21}$ .

$$c) \quad \text{When } b = 0, \quad E \cdot F = \begin{bmatrix} a & 0 \\ 0 & a \end{bmatrix} F = a \begin{bmatrix} 1 & 0 \\ 0 & 1 \end{bmatrix} F = aF$$

$$7. \quad a) \quad \begin{bmatrix} 2 & 0 \\ 0 & 2 \end{bmatrix} - 2 \begin{bmatrix} 1 & 0 \\ 0 & 1 \end{bmatrix} = \begin{bmatrix} 2 & 0 \\ 0 & 2 \end{bmatrix} - \begin{bmatrix} 2 & 0 \\ 0 & 2 \end{bmatrix} = \bar{O}_2$$

$$b) \quad A^3 - 2A - 3I_2 = \left( \begin{bmatrix} -1 & 2 \\ 0 & 3 \end{bmatrix} \cdot \begin{bmatrix} -1 & 2 \\ 0 & 3 \end{bmatrix} \right) - 2 \begin{bmatrix} -1 & 2 \\ 0 & 3 \end{bmatrix} - 3 \begin{bmatrix} 1 & 0 \\ 0 & 1 \end{bmatrix}$$

$$= \begin{bmatrix} 1 & 4 \\ 0 & 9 \end{bmatrix} - \begin{bmatrix} -2 & 4 \\ 0 & 6 \end{bmatrix} - \begin{bmatrix} 3 & 0 \\ 0 & 3 \end{bmatrix} = \begin{bmatrix} 0 & 0 \\ 0 & 0 \end{bmatrix} = \bar{O}_2$$

$$\begin{aligned}
 \text{c) } A^2 - 2A + 2I_2 &= \begin{bmatrix} 1 & 1 \\ -1 & 1 \end{bmatrix} \cdot \begin{bmatrix} 1 & 1 \\ -1 & 1 \end{bmatrix} - 2 \begin{bmatrix} 1 & 1 \\ -1 & 1 \end{bmatrix} + 2 \begin{bmatrix} 1 & 0 \\ 0 & 1 \end{bmatrix} \\
 &= \begin{bmatrix} 0 & 2 \\ -2 & 0 \end{bmatrix} - \begin{bmatrix} 2 & 2 \\ -2 & 2 \end{bmatrix} + \begin{bmatrix} 2 & 0 \\ 0 & 2 \end{bmatrix} = \begin{bmatrix} 0 & 0 \\ 0 & 0 \end{bmatrix} \\
 &= O_2
 \end{aligned}$$

$$\begin{aligned}
 \text{8. a) } (A + B)(A - B) &= \left( \begin{bmatrix} 2 & -1 \\ 0 & 1 \end{bmatrix} + \begin{bmatrix} 0 & 1 \\ 2 & 1 \end{bmatrix} \right) \left( \begin{bmatrix} 2 & -1 \\ 0 & 1 \end{bmatrix} - \begin{bmatrix} 0 & 1 \\ 2 & 1 \end{bmatrix} \right) \\
 &= \begin{bmatrix} 2 & 0 \\ 2 & 2 \end{bmatrix} \cdot \begin{bmatrix} 2 & -2 \\ -2 & 0 \end{bmatrix} = \begin{bmatrix} 4 & -4 \\ 0 & -4 \end{bmatrix}
 \end{aligned}$$

$$\begin{aligned}
 A^2 - B^2 &= \begin{bmatrix} 2 & -1 \\ 0 & 1 \end{bmatrix} \cdot \begin{bmatrix} 2 & -1 \\ 0 & 1 \end{bmatrix} - \begin{bmatrix} 0 & 1 \\ 2 & 1 \end{bmatrix} \cdot \begin{bmatrix} 0 & 1 \\ 2 & 1 \end{bmatrix} \\
 &= \begin{bmatrix} 4 & -3 \\ 0 & 1 \end{bmatrix} - \begin{bmatrix} 2 & 1 \\ 2 & 3 \end{bmatrix} = \begin{bmatrix} 2 & -4 \\ -2 & -2 \end{bmatrix} \neq \begin{bmatrix} 4 & -4 \\ 0 & -4 \end{bmatrix}
 \end{aligned}$$

$$\therefore (A + B)(A - B) \neq A^2 - B^2.$$

$$\begin{aligned}
 \text{b) } (A + B)(A + B) &= \left( \begin{bmatrix} 2 & -1 \\ 0 & 1 \end{bmatrix} + \begin{bmatrix} 0 & 1 \\ 2 & 1 \end{bmatrix} \right) \left( \begin{bmatrix} 2 & -1 \\ 0 & 1 \end{bmatrix} + \begin{bmatrix} 0 & 1 \\ 2 & 1 \end{bmatrix} \right) \\
 &= \begin{bmatrix} 2 & 0 \\ 2 & 2 \end{bmatrix} \cdot \begin{bmatrix} 2 & 0 \\ 2 & 2 \end{bmatrix} = \begin{bmatrix} 4 & 0 \\ 8 & 4 \end{bmatrix}
 \end{aligned}$$

$$\begin{aligned}
 A^2 + 2AB + B^2 &= \begin{bmatrix} 2 & -1 \\ 0 & 1 \end{bmatrix} \cdot \begin{bmatrix} 2 & -1 \\ 0 & 1 \end{bmatrix} + 2 \begin{bmatrix} 2 & -1 \\ 0 & 1 \end{bmatrix} \cdot \begin{bmatrix} 0 & 1 \\ 2 & 1 \end{bmatrix} \\
 &+ \begin{bmatrix} 0 & 1 \\ 2 & 1 \end{bmatrix} \cdot \begin{bmatrix} 0 & 1 \\ 2 & 1 \end{bmatrix} = \begin{bmatrix} 4 & -3 \\ 0 & 1 \end{bmatrix} + 2 \begin{bmatrix} -2 & 1 \\ 2 & 1 \end{bmatrix} \\
 &+ \begin{bmatrix} 2 & 1 \\ 2 & 3 \end{bmatrix} + \begin{bmatrix} 2 & 0 \\ 6 & 6 \end{bmatrix} \neq \begin{bmatrix} 4 & 0 \\ 8 & 4 \end{bmatrix}
 \end{aligned}$$

$$\therefore (A + B)(A + B) \neq A^2 + 2AB + B^2.$$

c) In using the distributive property in the set of reals  $(a + b)(a - b) = (a + b)a - (a + b)b = a^2 + ba - ab - b^2$ , this last expression is  $a^2 - b^2$  if  $ba - ab = 0$ . That is, if  $ba = ab$ . This is true.  $\therefore (a + b)(a - b) = a^2 - b^2$ . However, the multiplication over the set of matrices is not commutative. We cannot assert  $BA = -BA$ . Hence  $(A + B)(A - B) \neq A^2 - B^2$ .

d)  $(a + b)(a + b) = a^2 + ab + ba + b^2$ .  $ab + ba = 2ab$  if  $ab = ba$ . This is true for real numbers--not for matrices. Hence, if  $a, b$  are reals,  $(a + b)^2 = a^2 + 2ab + b^2$ . But if  $A$  and  $B$  are matrices,  $(A + B)^2 \neq A^2 + 2AB + B^2$ .

9. 
$$\begin{bmatrix} 0 & 0 \\ 1 & 0 \end{bmatrix} \cdot \begin{bmatrix} 0 & 0 \\ 1 & 0 \end{bmatrix} = \begin{bmatrix} 0 & 0 \\ 0 & 0 \end{bmatrix} = \bar{O}_2. \text{ Hence } A = \begin{bmatrix} 0 & 0 \\ 1 & 0 \end{bmatrix}$$

satisfies  $X^2 = \bar{O}_2$ . To find another matrix that

satisfies  $X^2 = \bar{O}_2$ , let  $X = \begin{bmatrix} x & y \\ z & w \end{bmatrix}$ . Then

$$\begin{bmatrix} x & y \\ z & w \end{bmatrix} \cdot \begin{bmatrix} x & y \\ z & w \end{bmatrix} = \begin{bmatrix} 0 & 0 \\ 0 & 0 \end{bmatrix} \text{ or}$$

$$(1) \quad x^2 + yz = 0 \qquad (2) \quad xy + yw = 0$$

$$(3) \quad xz + zw = 0 \qquad (4) \quad yz + w^2 = 0.$$

From (2),  $y(x + w) = 0$ ; from (3),  $z(x + w) = 0$ .

If  $x + w \neq 0$ ,  $y = 0$ ,  $z = 0$ ,  $w = 0$ .  $X = \begin{bmatrix} 0 & 0 \\ 0 & 0 \end{bmatrix}$ .

If  $x + w = 0$ , then values of  $x, y,$  and  $z$  that satisfy  $x^2 + yz = 0$  will give suitable values. For instance,



if  $y = -9$ ,  $z = 4$ , then  $x = 6$  (or  $-6$ ), and  $w = -6$  (or  $6$ ). Thus,

$$\begin{bmatrix} 6 & -9 \\ 4 & -6 \end{bmatrix} \cdot \begin{bmatrix} 6 & -9 \\ 4 & -6 \end{bmatrix} = \begin{bmatrix} 0 & 0 \\ 0 & 0 \end{bmatrix}.$$

10. a)  $\begin{bmatrix} 1 & 0 \\ 0 & 1 \end{bmatrix} \cdot \begin{bmatrix} 1 & 0 \\ 0 & 1 \end{bmatrix} = \begin{bmatrix} 1 & 0 \\ 0 & 1 \end{bmatrix}$

b)  $\begin{bmatrix} 1 & 0 \\ 0 & -1 \end{bmatrix} \cdot \begin{bmatrix} 1 & 0 \\ 0 & -1 \end{bmatrix} = \begin{bmatrix} 1 & 0 \\ 0 & 1 \end{bmatrix}$

c)  $\begin{bmatrix} -1 & 0 \\ 0 & 1 \end{bmatrix} \cdot \begin{bmatrix} -1 & 0 \\ 0 & 1 \end{bmatrix} = \begin{bmatrix} 1 & 0 \\ 0 & 1 \end{bmatrix}$

d)  $\begin{bmatrix} -1 & 0 \\ 0 & -1 \end{bmatrix} \cdot \begin{bmatrix} -1 & 0 \\ 0 & -1 \end{bmatrix} = \begin{bmatrix} 1 & 0 \\ 0 & 1 \end{bmatrix}$

There certainly are at least four square roots for the given matrix!

Yes, there are others.

In fact if  $x \neq 0$ , then

$$\begin{bmatrix} 0 & x \\ \frac{1}{x} & 0 \end{bmatrix} \cdot \begin{bmatrix} 0 & x \\ \frac{1}{x} & 0 \end{bmatrix} = \begin{bmatrix} 1 & 0 \\ 0 & 1 \end{bmatrix}$$

We have just examined the equation

$$X_2^2 - I_2 = \bar{0}_2$$

which is equivalent to

$$X_2^2 = I_2$$

and we have found that it has an infinite set for a solution set.

### 3.9 Multiplicative Inverses in $\mathcal{M}_2$ ( $1\frac{1}{2}$ - 2 days)

Having discovered that not all matrices in  $\mathcal{M}_2$  have inverses, the question naturally arises: How can one determine whether or not a given matrix is invertible? The answer is obtained in an

attempt to solve  $\begin{bmatrix} a & b \\ c & d \end{bmatrix} \cdot \begin{bmatrix} x & y \\ z & w \end{bmatrix} = \begin{bmatrix} 1 & 0 \\ 0 & 1 \end{bmatrix}$ , where the given

is  $\begin{bmatrix} a & b \\ c & d \end{bmatrix}$  and  $\begin{bmatrix} x & y \\ z & w \end{bmatrix}$  is a matrix that is the inverse of

$\begin{bmatrix} a & b \\ c & d \end{bmatrix}$ , if there is one. In the course of seeking a solution

of the four associated scalar equations, we find that a unique solution exists if and only if  $ad - bc \neq 0$ . This gives the expression  $ad - bc$  an importance, sufficient to give it a special representation. We use  $h$  as that representation, in accordance with some usage. Of course,  $h$  is the determinant of a  $2 \times 2$  matrix. We refrain from using the term "determinant," for we do not want to give beginners the impression that only  $\mathcal{M}_2$  matrices have determinants, and we do not want to face questions about determinants in general in an already full chapter.

Inverses are used extensively in this section to solve pairs of linear equations in two unknowns. Of course there are the classical methods to which our students have already been introduced, and they may be more comfortable with familiar methods. Nevertheless they should be encouraged to learn how to use the inverse of the coefficient matrix for two reasons.

First, they are building the notion of a matrix equation at least in the simple form  $AX = B$ , where  $A$  is the coefficient matrix (not necessarily a  $2 \times 2$  matrix),  $X = \begin{bmatrix} x \\ y \end{bmatrix}$  and  $B = \begin{bmatrix} a \\ b \end{bmatrix}$ . Second, they review the method introduced in Chapter 2 that can easily be programmed for electronic computers that solves a system of  $n$  linear equations in  $m$  unknowns, if a solution exists. This arises in many operation research problems, including linear programming. A third reason, if it is needed, is that the matrix method works exactly the same way for all systems of equations, while the classic methods can vary with the ingenuity that a student can bring to bear. (This last reason, of course, can be used to argue in favor of the classic method.)

We repeat here the suggestions: Do not assign all parts of a given exercise at once! Save some problems for review purposes as you go along in the text.

### 3.10 Exercise Solutions

1. a) The inverse of  $\begin{bmatrix} 2 & 0 \\ 0 & 1 \end{bmatrix}$  is  $\begin{bmatrix} \frac{1}{2} & 0 \\ 0 & 1 \end{bmatrix}$  ( $h = 2$ ).

b)  $\begin{bmatrix} 3 & 9 \\ 2 & 6 \end{bmatrix}$  has no inverse.  $h = 3 \cdot 6 - 9 \cdot 2 = 0$ .

c)  $\begin{bmatrix} 2 & 2 \\ 2 & 2 \end{bmatrix}$  has no inverse.  $h = 2 \cdot 2 - 2 \cdot 2 = 0$ .

d) For  $\begin{bmatrix} 4 & 2 \\ 3 & 1 \end{bmatrix}$ ,  $h = -2$ . Its inverse is  $\begin{bmatrix} -\frac{1}{2} & 1 \\ \frac{3}{2} & -2 \end{bmatrix}$ .

e) For  $\begin{bmatrix} -1 & 0 \\ 3 & 4 \end{bmatrix}$ ,  $h = -4$ . Its inverse is  $\begin{bmatrix} -1 & 0 \\ \frac{3}{4} & \frac{1}{4} \end{bmatrix}$ .

f) For  $\begin{bmatrix} 2 & -6 \\ -1 & 3 \end{bmatrix}$ ,  $h = 0$ . It has no inverse.

g) For  $\begin{bmatrix} 2 & 1 \\ -1 & -1 \end{bmatrix}$ ,  $h = -1$ . Its inverse is  $\begin{bmatrix} 1 & 1 \\ -1 & -2 \end{bmatrix}$ .

h) For  $\begin{bmatrix} a & b \\ \frac{1}{b} & \frac{1}{a} \end{bmatrix}$ ,  $h = 0$ . It has no inverse.

2. To be singular,  $h$  must equal 0.

a)  $3x - 6 = 0$ ,  $x = 2$ .

b.  $x^2 = 36$ ,  $x = 6$  or  $-6$ .

c)  $x^2 - 2x - 8 = 0$ ,  $(x - 4)(x + 2) = 0$ ,  $x = 4$  or  $-2$ .

d)  $x^2 - 3x + 2 - 2 = 0$ ,  $x(x - 3) = 0$ ,  $x = 0$  or  $3$ .

3. a)  $\begin{bmatrix} 2 & 0 \\ 0 & 2 \end{bmatrix} \cdot \begin{bmatrix} \frac{1}{2} & 0 \\ 0 & \frac{1}{2} \end{bmatrix} = \begin{bmatrix} 1 & 0 \\ 0 & 1 \end{bmatrix} = \begin{bmatrix} \frac{1}{2} & 0 \\ 0 & \frac{1}{2} \end{bmatrix} \cdot \begin{bmatrix} 2 & 0 \\ 0 & 2 \end{bmatrix} \therefore \begin{bmatrix} \frac{1}{2} & 0 \\ 0 & \frac{1}{2} \end{bmatrix} = A^{-1}$ .

b)  $kI = k \begin{bmatrix} 1 & 0 \\ 0 & 1 \end{bmatrix} = \begin{bmatrix} k & 0 \\ 0 & k \end{bmatrix} \frac{1}{k} I = \frac{1}{k} \begin{bmatrix} 1 & 0 \\ 0 & 1 \end{bmatrix} \cdot \begin{bmatrix} k & 0 \\ 0 & k \end{bmatrix}$

$$\begin{bmatrix} k & 0 \\ 0 & k \end{bmatrix} \cdot \begin{bmatrix} \frac{1}{k} & 0 \\ 0 & \frac{1}{k} \end{bmatrix} = \begin{bmatrix} 1 & 0 \\ 0 & 1 \end{bmatrix} = \begin{bmatrix} \frac{1}{k} & 0 \\ 0 & \frac{1}{k} \end{bmatrix} \cdot \begin{bmatrix} k & 0 \\ 0 & k \end{bmatrix}$$

4. Let  $\begin{bmatrix} x & y \\ z & w \end{bmatrix}$  be its own inverse. Then  $\begin{bmatrix} x & y \\ z & w \end{bmatrix} \cdot \begin{bmatrix} x & y \\ z & w \end{bmatrix}$

$$= \begin{bmatrix} 1 & 0 \\ 0 & 1 \end{bmatrix}$$

(1)  $x^2 + yz = 1$       (2)  $xy + yw = 0$       (3)  $xz + zw = 0$

(4)  $yz + w^2 = 1$       From (2),  $y(x + w) = 0$ ;

From (3),  $z(x + w) = 0$ . If  $y + w \neq 0$ ,  $y = 0$ ,  $z = 0$ ,  
 $x^2 = w^2 = 1$ ,  $x = \pm 1$ ,  $w = \pm 1$ .

Four possibilities arise, each of which gives a matrix that is its own inverse, namely

$$\begin{bmatrix} 1 & 0 \\ 0 & 1 \end{bmatrix}, \begin{bmatrix} 1 & 0 \\ 0 & -1 \end{bmatrix}, \begin{bmatrix} -1 & 0 \\ 0 & 1 \end{bmatrix}, \begin{bmatrix} -1 & 0 \\ 0 & -1 \end{bmatrix}$$

If  $x + w = 0$ , then  $x = -w$  and from (1) or (4),

$x^2 + yz = 1$ . This yields many possibilities, for

instance  $x = 6$ ,  $y = 7$ ,  $z = -5$ ,  $w = -6$  and

$$\begin{bmatrix} 6 & 7 \\ -5 & -6 \end{bmatrix} \cdot \begin{bmatrix} 6 & 7 \\ -5 & -6 \end{bmatrix} = \begin{bmatrix} 1 & 0 \\ 0 & 1 \end{bmatrix}.$$

In general, let  $x = a$ ,  $y = b$ , then  $z = \frac{1 - a^2}{b}$ ,  $w = -a$

and  $\begin{bmatrix} a & b \\ \frac{1 - a^2}{b} & -a \end{bmatrix}$  is its own inverse for any value of

$a$  and any non-zero value of  $b$ .

5. For  $\bar{U}_2$ ,  $h = 0$ .  $\therefore \bar{U}_2$  is a singular matrix.

6. Assume  $A$  has inverse  $A^{-1}$ . Then  $A^{-1}AB = A^{-1}\bar{U}$  or  $B = \bar{U}$ .

But  $B \neq \bar{U}$ . Therefore  $A$  is not invertible.

7. Let  $A = \begin{bmatrix} a & b \\ c & d \end{bmatrix}$  and  $B = \begin{bmatrix} e & f \\ g & h \end{bmatrix}$ . Then  $AB = \begin{bmatrix} ae+bg & af+bh \\ ce+dg & cf+dh \end{bmatrix}$

$h$  of  $AB = aecf + aedh + bgcf + bdgh - ceaf - cebh -$

$dgaf - dgbh$

$$= aedh + bgcf - cebh - dgaf$$

$$= (ad - bc)(eh - gf).$$

The last product is the product of the  $h$ 's of  $A$  and  $B$ .

Since  $B$  is not invertible,  $eh - gf = 0$ . Then  $h$  of  $AB = 0$

and  $AB$  is not invertible. By the same reasoning  $BA$  is also not invertible.

8. a) Using the results in the proof of Exercise 7, both  $h$  of  $A$  and  $h$  of  $B$  are not zero. Hence  $h$  of  $AB$  or  $BA$  is not zero, and  $BA$  and  $AB$  are invertible.
- b) Consider  $AB \cdot B^{-1}A^{-1}$ , associating its factors in a variety of ways.  $A(B \cdot B^{-1})A^{-1} = AA^{-1} = I$ . Also  $AB \cdot B^{-1}A^{-1} = (AB)(B^{-1}A^{-1})A^{-1} = I$ .  $\therefore (AB)^{-1} = B^{-1}A^{-1}$ .

9. a) The inverse of  $\begin{bmatrix} 1 & 3 \\ 2 & 5 \end{bmatrix}$  is  $\begin{bmatrix} -5 & 3 \\ 2 & -1 \end{bmatrix}$  ( $h = -1$ )

$$\begin{bmatrix} -5 & 3 \\ 2 & -1 \end{bmatrix} \cdot \begin{bmatrix} 1 \\ 2 \end{bmatrix} = \begin{bmatrix} -1 \\ 2 \end{bmatrix}. \quad (x, y) = (-1, 2).$$

Check.  $-1 + 3(2) = 5, 2(-1) + 5(2) = 8.$

- b) The inverse of  $\begin{bmatrix} 3 & 2 \\ 2 & 1 \end{bmatrix}$  is  $\begin{bmatrix} -1 & 2 \\ 2 & -3 \end{bmatrix}$  ( $h = -1$ )

$$\begin{bmatrix} -1 & 2 \\ 2 & -3 \end{bmatrix} \cdot \begin{bmatrix} 3 \\ 2 \end{bmatrix} = \begin{bmatrix} 1 \\ 1 \end{bmatrix}. \quad (x, y) = (1, 1).$$

Check.  $3(1) + 2(1) = 5, 2(1) + (-1)(1) = 1.$

- c) The inverse of  $\begin{bmatrix} 5 & 3 \\ 2 & 1 \end{bmatrix}$  is  $\begin{bmatrix} -1 & 3 \\ 2 & -5 \end{bmatrix}$  ( $h = -1$ )

$$\begin{bmatrix} -1 & 3 \\ 2 & -5 \end{bmatrix} \cdot \begin{bmatrix} 5 \\ 2 \end{bmatrix} = \begin{bmatrix} 2 \\ 1 \end{bmatrix} \quad (x, y) = (2, 1).$$

Check.  $5(2) + 3(1) = 13, 2(2) + (-1)(1) = 3.$

- d) The inverse of  $\begin{bmatrix} 2 & -7 \\ 1 & -3 \end{bmatrix}$  is  $\begin{bmatrix} -3 & 7 \\ -1 & 2 \end{bmatrix}$  ( $h = 1$ )

$$\begin{bmatrix} -3 & 7 \\ -1 & 2 \end{bmatrix} \cdot \begin{bmatrix} 2 \\ 1 \end{bmatrix} = \begin{bmatrix} 5 \\ 1 \end{bmatrix} \quad (x, y) = (5, 1).$$

Check.  $2(5) - 7(1) = 3$ ,  $(5) - 3(1) = 2$ .

e) The inverse of  $\begin{bmatrix} 3 & 1 \\ 4 & 2 \end{bmatrix}$  is  $\begin{bmatrix} 1 & \frac{1}{2} \\ -2 & 3 \end{bmatrix}$  ( $h = -2$ )

$$\begin{bmatrix} 1 & \frac{1}{2} \\ -2 & 3 \end{bmatrix} \cdot \begin{bmatrix} 14 \\ 20 \end{bmatrix} = \begin{bmatrix} 4 \\ 2 \end{bmatrix}. \quad (x, y) = (4, 2)$$

Check.  $3(4) + 2 = 14$ ,  $4(4) + 2(2) = 20$ .

f) The inverse of  $\begin{bmatrix} 4 & 3 \\ 5 & -1 \end{bmatrix}$  is  $\frac{1}{19} \begin{bmatrix} 1 & 3 \\ 5 & -4 \end{bmatrix}$  ( $h = -19$ )

$$\frac{1}{19} \begin{bmatrix} 1 & 3 \\ 5 & -4 \end{bmatrix} \cdot \begin{bmatrix} 26 \\ 4 \end{bmatrix} = \frac{1}{19} \begin{bmatrix} 38 \\ 114 \end{bmatrix}. \quad (x, y) = (2, 6)$$

Check.  $4(2) + 3(6) = 26$ ,  $5(2) - 6 = 4$

g) The inverse of  $\begin{bmatrix} 3 & 4 \\ 5 & -7 \end{bmatrix}$  is  $\frac{1}{41} \begin{bmatrix} 7 & 4 \\ 5 & -3 \end{bmatrix}$  ( $h = -41$ )

$$\frac{1}{41} \begin{bmatrix} 7 & 4 \\ 5 & -3 \end{bmatrix} \cdot \begin{bmatrix} 1 \\ -12 \end{bmatrix} = \frac{1}{41} \begin{bmatrix} -41 \\ -41 \end{bmatrix}. \quad (r, s) = (-1, 1).$$

Check.  $3(-1) + 4(1) = 1$ ,  $5(-1) - 7(1) = -12$ .

h) The inverse of  $\begin{bmatrix} 5 & -3 \\ 6 & 2 \end{bmatrix}$  is  $\frac{1}{28} \begin{bmatrix} 2 & 3 \\ -6 & 5 \end{bmatrix}$  ( $h = 28$ )

$$\frac{1}{28} \begin{bmatrix} 2 & 3 \\ -6 & 5 \end{bmatrix} \cdot \begin{bmatrix} 27 \\ 10 \end{bmatrix} = \frac{1}{28} \begin{bmatrix} 84 \\ -112 \end{bmatrix} \quad (u, y) = (3, -4).$$

Check.  $5(3) - 3(-4) = 27$ ,  $6(3) + 2(-4) = 10$ .

i) The inverse of  $\begin{bmatrix} a & b \\ b & a \end{bmatrix}$  is  $\frac{1}{a^2 - b^2} \begin{bmatrix} a & -b \\ -b & a \end{bmatrix}$

( $h = a^2 - b^2$ )

$$\frac{1}{a^2 - b^2} \begin{bmatrix} a & -b \\ -b & a \end{bmatrix} \cdot \begin{bmatrix} a \\ b \end{bmatrix} = \frac{1}{a^2 - b^2} \begin{bmatrix} a^2 - b^2 \\ 0 \end{bmatrix} \quad (x, y) = (1, 0).$$

Check.  $a(1) + b(0) = a$ ,  $b(1) + a(0) = b$ .

j) The inverse of  $\begin{bmatrix} a & b \\ b & a \end{bmatrix}$  is  $\frac{1}{a^2 - b^2} \begin{bmatrix} a & -b \\ -b & a \end{bmatrix}$ .

$$\frac{1}{a^2 - b^2} \begin{bmatrix} a & -b \\ -b & a \end{bmatrix} \cdot \begin{bmatrix} 1 \\ 2 \end{bmatrix} = \frac{1}{a^2 - b^2} \begin{bmatrix} a & -2b \\ -b & +2a \end{bmatrix}, (x, y) = \left( \frac{a - 2b}{a^2 - b^2}, \frac{2a - b}{a^2 - b^2} \right).$$

Check.  $a\left(\frac{a - 2b}{a^2 - b^2}\right) + b\left(\frac{2a - b}{a^2 - b^2}\right) = \frac{a^2 - b^2}{a^2 - b^2} = 1$

$$b\left(\frac{a - 2b}{a^2 - b^2}\right) + a\left(\frac{2a - b}{a^2 - b^2}\right) = \frac{2a^2 - 2b^2}{a^2 - b^2} = 2.$$

k) The inverse of  $\begin{bmatrix} a & -b \\ b & -a \end{bmatrix}$  is  $\frac{1}{b^2 - a^2} \begin{bmatrix} -a & b \\ -b & a \end{bmatrix}$

$(h = b^2 - a^2).$

$$\frac{1}{b^2 - a^2} \begin{bmatrix} -a & b \\ -b & a \end{bmatrix} \cdot \begin{bmatrix} b \\ a \end{bmatrix} = \frac{1}{b^2 - a^2} \begin{bmatrix} 0 \\ -b^2 + a^2 \end{bmatrix}.$$

$(x, y) = (0, -1).$

Check.  $a(0) - b(-1) = b$ ,  $b(0) - a(-1) = a$ .

l) The inverse of  $\begin{bmatrix} \frac{1}{2} & \frac{1}{3} \\ \frac{1}{3} & \frac{1}{4} \end{bmatrix}$  is  $72 \begin{bmatrix} \frac{1}{4} & -\frac{1}{3} \\ -\frac{1}{3} & \frac{1}{2} \end{bmatrix}$ .

$(h = \frac{1}{8} - \frac{1}{9} = \frac{1}{72})$

$$72 \begin{bmatrix} \frac{1}{4} & -\frac{1}{3} \\ -\frac{1}{3} & \frac{1}{2} \end{bmatrix} \cdot \begin{bmatrix} 20 \\ 14 \end{bmatrix} = 72 \begin{bmatrix} \frac{1}{3} \\ \frac{1}{3} \end{bmatrix}. (x, y) = (24, 24)$$

Check.  $\frac{1}{2}(24) + \frac{1}{3}(24) = 20$ ,  $\frac{1}{3}(24) + \frac{1}{4}(24) = 14$ .



10. Proof of Theorem 11: " $A^{-1}$  is unique"

Suppose  $A$  has another inverse, say  $C$ . Then

$CA = I_2$	hypothesis
$(CA)A^{-1} = I_2A^{-1}$	right operation
$C(AA^{-1}) = I_2A^{-1}$	associativity
$C(AA^{-1}) = A^{-1}$	identity property
$CI_2 = A^{-1}$	definition of inverse
$C = A^{-1}$	identity property

3.11 The Ring of 2 X 2 Matrices (1 -  $1\frac{1}{2}$  days)

A ring is a less restrictive mathematical system than a field. While every field is a ring - the converse statement is not true. Note and emphasize that in the definition of a ring we do not assume that 1) multiplication is commutative; 2) there is a multiplicative identity; 3) there is a multiplicative inverse for each element. We can have, therefore, examples of rings which in addition to the basic properties of a ring also the properties 1), 2), or 3). A ring which has all the properties 1), 2), and 3) is a field.

Emphasize the importance of proving all the postulates for a ring in showing that a given system is a ring.

Rings arose from a study of the integers - and the integers, matrices (certain subsets of them), and finite number systems whose moduli are not prime are the best illustrations of rings that are not also fields.

The exercises attempt to give samples of rings which lack

one or more of the three additional properties listed above.

### 3.12 Exercises

1. a)  $(M_2, +)$  is an abelian group since it is a subset of  $m \times n$  matrices with matrix addition - which we proved to be a group.

b)  $(M_2, \cdot)$  is an operational system for

$$\begin{bmatrix} a & b \\ c & d \end{bmatrix} \cdot \begin{bmatrix} e & f \\ g & h \end{bmatrix} = \begin{bmatrix} ae + bg & af + bh \\ ce + dg & cf + dh \end{bmatrix}$$

which is a  $2 \times 2$  matrix.

$(M_2, \cdot)$  has the distributive property for:

$$\begin{aligned} \begin{bmatrix} a & b \\ c & d \end{bmatrix} \cdot \left( \begin{bmatrix} e & f \\ g & h \end{bmatrix} + \begin{bmatrix} k & l \\ m & n \end{bmatrix} \right) &= \begin{bmatrix} a & b \\ c & d \end{bmatrix} \cdot \begin{bmatrix} e+k & f+l \\ g+m & h+n \end{bmatrix} \\ &= \begin{bmatrix} a(e+k) + b(g+m) & a(f+l) + b(h+n) \\ c(e+k) + d(g+m) & c(f+l) + d(h+n) \end{bmatrix} \end{aligned}$$

and

$$\begin{aligned} \begin{bmatrix} ae + bh & af + bh \\ ce + dg & cf + dh \end{bmatrix} + \begin{bmatrix} ak + bm & al + bn \\ ck + dm & cl + dn \end{bmatrix} \\ = \begin{bmatrix} ae + bh + ak + bm & af + bh + al + bn \\ ce + dg + ch + dm & cf + dh + cl + dn \end{bmatrix} \end{aligned}$$

Similarly for right hand distributivity,  $(M_2, \cdot)$  has associativity for:

$$\begin{aligned} \begin{bmatrix} a & b \\ c & d \end{bmatrix} \cdot \left( \begin{bmatrix} e & f \\ g & h \end{bmatrix} \cdot \begin{bmatrix} k & l \\ m & n \end{bmatrix} \right) &= \begin{bmatrix} a & b \\ c & d \end{bmatrix} \cdot \begin{bmatrix} ek + fm & el + fd \\ gk + hm & gl + hn \end{bmatrix} \\ = \begin{bmatrix} a(ek + fm) + b(gk + hm) & a(el + fd) + b(gl + hn) \\ c(ek + fm) + d(gk + hm) & c(el + fd) + d(gl + hn) \end{bmatrix} \end{aligned}$$

and

$$\left( \begin{bmatrix} a & b \\ c & d \end{bmatrix} \cdot \begin{bmatrix} e & f \\ g & h \end{bmatrix} \right) \cdot \begin{bmatrix} k & l \\ m & n \end{bmatrix} = \begin{bmatrix} ae + bg & af + bh \\ ce + dg & cf + dh \end{bmatrix} \cdot \begin{bmatrix} k & l \\ m & n \end{bmatrix}$$

$$= \begin{bmatrix} (ae + bg)k + (af + bh)m & (ae + bg)l + (af + bh)n \\ (ce + dm)k + (cf + dh)m & (ce + dm)l + (ce + dm)n \end{bmatrix}$$

2. The crux of the proof lies in showing that if A and B are invertible 2 X 2 matrices, then so is AB.

$$\text{Let } A = \begin{bmatrix} a & b \\ c & d \end{bmatrix} \quad \text{and } B = \begin{bmatrix} e & f \\ g & h \end{bmatrix}$$

If A and B are invertible then

$$ah - cb \neq 0 \quad \text{and} \quad eh - gf \neq 0$$

$$\text{Now } AB = \begin{bmatrix} ae + bg & af + bh \\ ce + dg & cf + dh \end{bmatrix}$$

To show that AB is invertible we must show that

$$(ae + bg)(cf + dh) - (ce + dg)(af + bh) \neq 0$$

By expanding this product we get

$$\begin{aligned} & \cancel{aeaf} + aedh + bgcf + \cancel{bgdh} - \cancel{ceaf} - cebh - dgaf - \cancel{dgbh} \\ &= aedh - dgaf - cebh + bgcf \\ &= ad(eh - gf) - cb(eh - gf) \\ &= (ad - bc)(eh - gf) \neq 0 \end{aligned}$$

3. We know that  $(\mathbb{Z}, +)$  is an abelian group. We also know that  $(\mathbb{Z}, \cdot)$  is an operational group which obeys the commutative, associative, and distributive principle. Therefore  $(\mathbb{Z}, +, \cdot)$  is a ring. It is distributive and has an identity but there are no multiplicative inverses.
4.  $(\mathbb{E}, +)$  is a commutative group with 0 as its identity.  $(\mathbb{E}, \cdot)$  is an operational group - with commutativity, associativity, and distributivity - but no identity.

Therefore  $(E, +, \cdot)$  is a commutative ring without identity or multiplicative inverses.

5.  $(R, +)$  and  $(R, \cdot)$  are both commutative groups. We have the additive identity 0, and the multiplicative identity, 1.  $(R, +, \cdot)$  therefore is a ring. If we exclude, as we usually do, the multiplicative identity - there is a multiplicative inverse for each element and therefore  $(R, +, \cdot)$  is a field.

6. The Cayley tables for  $(Z_7, +, \cdot)$  are

+	0	1	2	3	4	5	6	.	0	1	2	3	4	5	6
0	0	1	2	3	4	5	6	0	0	0	0	0	0	0	0
1	1	2	3	4	5	6	0	1	0	1	2	3	4	5	6
2	2	3	4	5	6	0	1	2	0	2	4	6	1	3	5
3	3	4	5	6	0	1	2	3	0	3	6	2	5	1	4
4	4	5	6	0	1	2	3	4	0	4	1	5	2	6	3
5	5	6	0	1	2	3	4	5	0	5	3	1	6	4	2
6	6	0	1	2	3	4	5	6	0	6	5	4	3	2	1

It is clear that  $(Z_7, +)$  and  $(Z_7, \cdot)$  are abelian groups with identity elements 0 and 1. Therefore,  $(Z_7, +, \cdot)$  is a commutative ring with an identity. Moreover the elements 1, 2, 3, 4, 5, 6 (the non-zero elements) also form an abelian group under multiplication. Therefore,  $(Z_7, +, \cdot)$  is a field - a finite one.

7. The Cayley tables for  $(Z_6, +, \cdot)$  are

+	0	1	2	3	4	5
0	0	1	2	3	4	5
1	1	2	3	4	5	0
2	2	3	4	5	0	1
3	3	4	5	0	1	2
4	4	5	0	1	2	3
5	5	0	1	2	3	4

·	0	1	2	3	4	5
0	0	0	0	0	0	0
1	0	1	2	3	4	5
2	0	2	4	0	2	4
3	0	3	0	3	0	3
4	0	4	2	0	4	2
5	0	5	4	3	2	1

$(Z_6, +)$  is a commutative group and  $(Z_6, \cdot)$  is an operational system which obeys the commutative, associative, and distributive property.  $(Z_6, +, \cdot)$  is a commutative ring with identity elements 0 and 1. However, we find

$$2 \cdot 3 = 3 \cdot 2 = 0$$

$$3 \cdot 4 = 4 \cdot 3 = 0$$

and yet  $2 \neq 0$ ,  $3 \neq 0$ ,  $4 \neq 0$ .

Here we have examples of

$$ab = 0 \text{ with } a \neq 0 \text{ and } b \neq 0.$$

Remember, such numbers in a system are called divisors of zero. Consequently,  $(Z_6, +, \cdot)$  is not a field.

8. a)

·	$e_{11}$	$e_{12}$	$e_{21}$	$e_{22}$
$e_{11}$	$e_{11}$	$e_{12}$	0	0
$e_{12}$	0	0	$e_{11}$	$e_{12}$
$e_{21}$	$e_{21}$	$e_{22}$	0	0
$e_{22}$	0	0	$e_{21}$	$e_{22}$

b) We know - aside from the table - that the set  $e_{11}, e_{12}, e_{21}, e_{22}$  form a commutative group under addition. We note, from the table, that the system is an operational system obeying the associative and distributive laws. Therefore  $(e_{ij}, +, \cdot)$  is a non-commutative ring without an identity. We also note that  $e_{11}, e_{12}, e_{21}, e_{22}$  are all divisors of zero.

$$c) e_{11} + e_{22} = \begin{bmatrix} 1 & 0 \\ 0 & 1 \end{bmatrix} = I_2 .$$

### 3.13 A Field of 2 X 2 Matrices (1 day)

One of the purposes of this section is to emphasize that a field is a special kind of ring and a ring is a generalized kind of field.

Another purpose is to select a special subset of 2 X 2 matrices that has a useful connection with a future topic - complex numbers.

The set  $Y$ , of course, is isomorphic with the field of complex numbers. Complex numbers are treated in Course IV, and they should not be introduced now. However, for your information let's point out the correspondence that can be set up.

$$\begin{bmatrix} a & -b \\ b & a \end{bmatrix} = a \begin{bmatrix} 1 & 0 \\ 0 & 1 \end{bmatrix} + b \begin{bmatrix} 0 & -1 \\ 1 & 1 \end{bmatrix} = a \cdot I + b \cdot J$$

$$a \cdot 1 + b \cdot i \quad \text{where } i = \sqrt{-1}.$$

### 3.14 Exercise Solutions

1. d), 8), h), i), possibly, j)

2. d) does not have an inverse.

$$g) \begin{bmatrix} \frac{1}{2} & \frac{-1}{2} \\ \frac{1}{2} & \frac{1}{2} \end{bmatrix}$$

$$h) \begin{bmatrix} \frac{\sqrt{3}}{5} & \frac{1}{5} \\ \frac{-1}{5} & \frac{\sqrt{3}}{5} \end{bmatrix}$$

i) If  $a = d$  and  $b = -c$  and  $ad - bc = a^2 + b^2 \neq 0$  then the matrix has an inverse and it is

$$\begin{bmatrix} \frac{a}{a^2 + b^2} & -\frac{a}{a^2 + b^2} \\ \frac{b}{a^2 + b^2} & \frac{a}{a^2 + b^2} \end{bmatrix}$$

$$j) \begin{bmatrix} \frac{\sqrt{2} + 1}{4\sqrt{2}} & -\frac{1 - \sqrt{2}}{4\sqrt{2}} \\ -\frac{\sqrt{2} - 1}{4\sqrt{2}} & \frac{\sqrt{2} + 1}{4\sqrt{2}} \end{bmatrix}$$

3. Since  $Y$  is a subset of  $m \times n$  matrices (in fact of  $2 \times 2$  matrices), we know by previous work that  $(Y, +)$  is an abelian group.

Since in  $\begin{bmatrix} x & -y \\ y & x \end{bmatrix}$   $x^2 + y^2$  is positive if  $x \neq 0$  and

$y \neq 0$ , we know that every element of  $Y$  has a multiplicative inverse. To show that  $Y$  is a field, we need to show that

$$Y_1 Y_2 \in Y$$

$$\text{and } Y_1 Y_2 = Y_2 Y_1.$$

$$\text{Let } Y_1 = \begin{bmatrix} x_1 & -y_1 \\ y_1 & x_1 \end{bmatrix} \text{ and } Y_2 = \begin{bmatrix} x_2 & -y_2 \\ y_2 & x_2 \end{bmatrix}$$

$$\text{Now: } Y_1 Y_2 = \begin{bmatrix} x_1 x_2 - y_1 y_2 & -x_1 y_2 - y_1 x_2 \\ y_1 x_2 + x_1 y_2 & -y_1 y_2 + x_1 x_2 \end{bmatrix}$$

and this is of the form

$$\begin{bmatrix} x & -y \\ y & x \end{bmatrix}$$
$$Y_1 Y_2 = \begin{bmatrix} x_1 x_2 - y_1 y_2 & -x_1 y_2 - y_1 x_2 \\ y_1 x_2 + x_1 y_2 & -y_1 y_2 + x_1 x_2 \end{bmatrix}$$

and

$$Y_2 Y_1 = \begin{bmatrix} x_2 x_1 - y_2 y_1 & -x_2 y_1 - y_2 x_1 \\ y_2 x_1 + x_2 y_1 & -y_2 y_1 + x_2 x_1 \end{bmatrix}$$

and therefore  $Y_1 Y_2 = Y_2 Y_1$  and  $Y$  is a field.

4. Consider the set  $G$  of  $2 \times 2$  matrices

$$\begin{bmatrix} x & -y \\ y & x \end{bmatrix}$$

such that  $x^2 + y^2 = 1$ . The system  $(G, \cdot)$  is a group.

This is a special case of Theorem 14.

5. Consider the points  $(a, b)$  in the plane such that  $a^2 + b^2 = 1$ . They are clearly the points on the circle with center at the origin and radius 1 - the unit circle.

The correspondence

$$(a, b) \longleftrightarrow \begin{bmatrix} a & -b \\ b & a \end{bmatrix}$$

is one-to-one.



The inverse of  $\begin{bmatrix} a & -b \\ b & a \end{bmatrix}$  is  $\begin{bmatrix} a & b \\ -b & a \end{bmatrix}$

and, with the above correspondence in mind,

$$\begin{bmatrix} a & b \\ -b & a \end{bmatrix} \longleftrightarrow (x, -y)$$

or, the reflection of the point  $(x, y)$  in the x-axis.

### 3.16 Review Exercise Solutions

$$1. \quad 2X + \begin{bmatrix} 3 & 2 \\ 1 & 5 \end{bmatrix} = 3X - \begin{bmatrix} 3 & 6 \\ 9 & 12 \end{bmatrix}, \quad \begin{bmatrix} 6 & 8 \\ 10 & 17 \end{bmatrix} = X$$

Check.  $2 \begin{bmatrix} 6 & 8 \\ 10 & 17 \end{bmatrix} + \begin{bmatrix} 3 & 2 \\ 1 & 5 \end{bmatrix} = 3 \begin{bmatrix} 6 & 8 \\ 10 & 17 \end{bmatrix} - \begin{bmatrix} 1 & 2 \\ 3 & 4 \end{bmatrix},$

$$\begin{bmatrix} 15 & 18 \\ 21 & 39 \end{bmatrix} = 3 \begin{bmatrix} 5 & 6 \\ 7 & 13 \end{bmatrix}.$$

2. To show that  $(Z_4, +, \cdot)$  is a ring, we show

(i)  $(Z_4, +)$  is an abelian group. This has already been done in preceding courses.

(ii)  $(Z_4, \cdot)$  is an operational system, as can be shown in its Cayley table; also, it is associative.

(iii) Using tables for  $(Z_4, +)$  and  $(Z_4, \cdot)$ , we can show that  $\cdot$  distributes over  $+$ , by considering cases.

3. a) The inverse of  $\begin{bmatrix} 4 & 1 \\ 11 & 3 \end{bmatrix}$  is  $\begin{bmatrix} 3 & -1 \\ -11 & 4 \end{bmatrix}$ . ( $h = 1$ ).

b)  $\begin{bmatrix} 4 & 6 \\ 2 & 3 \end{bmatrix}$  has no inverse because  $h = 0$ .

c) The inverse of  $\begin{bmatrix} 4 & 6 \\ 3 & 2 \end{bmatrix}$  ( $h = -10$ ) is  $\frac{-1}{10} \begin{bmatrix} 2 & -6 \\ -3 & 4 \end{bmatrix}$ .

d)  $\begin{bmatrix} -4 & -2 \\ -2 & -1 \end{bmatrix}$  has no inverse because  $h = (-4)(-1) - (-2)(-2) = 0$ .

4.  $\begin{bmatrix} x & y \end{bmatrix} \cdot \begin{bmatrix} 3 & 2 \\ -1 & 2 \end{bmatrix} \cdot \begin{bmatrix} x \\ y \end{bmatrix} = [3x - y \quad 2x + 2y] \cdot \begin{bmatrix} x \\ y \end{bmatrix} = [3x^2 - y + 2xy + 2y^2] = [3x^2 + xy + 2y^2]$ .

5.  $\begin{bmatrix} 1 & 4 \\ 2 & 3 \end{bmatrix} \cdot \begin{bmatrix} 1 & 4 \\ 2 & 3 \end{bmatrix} - 4 \begin{bmatrix} 1 & 4 \\ 2 & 3 \end{bmatrix} - 5 \begin{bmatrix} 1 & 0 \\ 0 & 1 \end{bmatrix} = \begin{bmatrix} 9 & 16 \\ 8 & 17 \end{bmatrix} - \begin{bmatrix} 4 & 16 \\ 8 & 12 \end{bmatrix} - \begin{bmatrix} 5 & 0 \\ 0 & 5 \end{bmatrix} = \begin{bmatrix} 0 & 0 \\ 0 & 0 \end{bmatrix}$ .

6. To be a multiplicative identity,  $A \begin{bmatrix} 1 & 4 \\ 2 & 3 \\ 5 & 5 \end{bmatrix}$  should equal

$I_3$  for all  $A \in M_3$ . This is not so.

7.  $\begin{bmatrix} 1 & 1 & 1 & 1 & 1 \\ 1 & 2 & 2 & 2 & 2 \\ 1 & 2 & 3 & 3 & 3 \\ 1 & 2 & 3 & 4 & 4 \end{bmatrix}$

8. Since  $x^2 + x - 1 = 0$ ,  $x^2 + x = 1$  and  $-1 = -x^2 - x$ . Also  $x = x$  and  $0 = 0$ .

Therefore  $\begin{bmatrix} x^2+x & -1 \\ x & 0 \end{bmatrix} = \begin{bmatrix} 1 & -x^2-x \\ x & 0 \end{bmatrix}$ .

9. Transpose of A  $\begin{bmatrix} 3 & 0 & 1 \\ -1 & 0 & 2 \end{bmatrix}$

Transpose of B  $\begin{bmatrix} 1 \\ 2 \\ 3 \end{bmatrix}$

$$10. \begin{bmatrix} 0 & 0 \\ 1 & 0 \end{bmatrix} \cdot \begin{bmatrix} 0 & 0 \\ 1 & 0 \end{bmatrix} = \begin{bmatrix} 0 & 0 \\ 0 & 0 \end{bmatrix}$$

Any matrix  $\begin{bmatrix} 0 & 0 \\ a & 0 \end{bmatrix}$   $a \in \mathbb{R}$ .

$$11. \begin{bmatrix} 0 & 1 \\ 1 & 0 \end{bmatrix} \cdot \begin{bmatrix} 0 & -1 \\ 1 & 0 \end{bmatrix} = \begin{bmatrix} 1 & 0 \\ 0 & -1 \end{bmatrix}$$

$$\begin{bmatrix} 0 & -1 \\ 1 & 0 \end{bmatrix} \cdot \begin{bmatrix} 0 & 1 \\ 1 & 0 \end{bmatrix} = \begin{bmatrix} -1 & 0 \\ 0 & 1 \end{bmatrix}$$

We note that  $AB = -BA$ .

In this case we say that multiplication is anti-commutative.

12. a) It is a ring.

It is easy to see that, if  $Q$  is the set of numbers  $a + b\sqrt{3}$  ( $a$  and  $b$  rational),  $(Q, +)$  is a commutative group.

$$\text{Let } x_1 = a_1 + b_1\sqrt{3} \quad x_2 = a_2 + b_2\sqrt{3}$$

$$\begin{aligned} \text{Then } x_1 x_2 &= (a_1 + b_1\sqrt{3})(a_2 + b_2\sqrt{3}) \\ &= (a_1 a_2 + 3b_1 b_2) + (a_1 b_2 + a_2 b_1)\sqrt{3} \end{aligned}$$

so  $(Q, \cdot)$  is an operational system. Associativity and distributivity can be proved similarly.

b) It is not a ring - and we need only a counter-example.

$$\text{e.g. } \frac{1}{2} \cdot \frac{3}{2} = \frac{3}{4} \text{ is not in the set.}$$

13. Suppose  $A$  has an inverse  $A^{-1}$

$$\text{Then } A^{-1} \cdot \bar{0} = \bar{0}$$

$$A^{-1}(AB) = \bar{0}$$

$$(A^{-1}A)(B) = \bar{0}$$

$$I \cdot B = \bar{0}$$

$$\text{or } B = \bar{0} \quad \text{contrary to hypothesis}$$

that  $B \neq \bar{0}$ .

B can have an inverse only if  $A = \bar{0}$ .

If B has an inverse  $B^{-1}$

$$\text{Then } \bar{0} = \bar{0}B^{-1} = (AB)B^{-1}$$

$$= A(BB^{-1})$$

$$= AI = A$$

$$\text{i.e. } A = \bar{0}.$$

### Chapter Test Items

1. Write a 3 X 3 matrix with elements  $a_{ij}$  such that

$$a_{ii} = 0, a_{ij} = 3i - 2j \quad \text{for } i \neq j.$$

2. If

$$A = \begin{bmatrix} 8 & 12 \\ 3 & 5 \end{bmatrix}, \quad B = \begin{bmatrix} 8 & 2 \\ 7 & 2 \end{bmatrix}, \quad C = \begin{bmatrix} 8 & -4 \\ -2 & 1 \end{bmatrix}$$

find the matrix

$$2A - B - C.$$

3. For the matrices A, B, C in ex. 2, find:

a)  $A(B \cdot C)$

b)  $AB - BC$

c)  $3A - IB + IC$

4. Find the inverses, if they exist, for matrices A, B, C in ex. 2.

5. Show that the set of invertible 2 X 2 matrices form a multiplicative group that is not abelian.

6. Prove: If a matrix  $D$  in  $M_2$  is invertible and  $E$  is its left inverse, then  $E$  is also its right inverse.
7. Prove that multiplication is commutative for matrices of the form

$$\begin{bmatrix} x & y \\ -y & x \end{bmatrix} \quad x, y \in \mathbb{R}.$$

Y. Suggested Test Items - Solutions

1. 
$$\begin{bmatrix} 0 & -1 & -3 \\ 4 & 0 & 0 \\ 7 & 5 & 0 \end{bmatrix}$$

2. 
$$2 \begin{bmatrix} 8 & 12 \\ 3 & 5 \end{bmatrix} - \begin{bmatrix} 8 & 2 \\ 7 & 2 \end{bmatrix} - \begin{bmatrix} 8 & -4 \\ -2 & 1 \end{bmatrix}$$

$$\begin{bmatrix} 16 & 24 \\ 6 & 10 \end{bmatrix} - \begin{bmatrix} 8 & 2 \\ 7 & 2 \end{bmatrix} - \begin{bmatrix} 8 & -4 \\ -2 & 1 \end{bmatrix} = \begin{bmatrix} 0 & 26 \\ 1 & 7 \end{bmatrix}$$

3. a) 
$$\begin{bmatrix} 8 & 12 \\ 3 & 5 \end{bmatrix} \cdot \begin{bmatrix} 8 & 2 \\ 7 & 2 \end{bmatrix} \cdot \begin{bmatrix} 8 & -4 \\ -2 & 1 \end{bmatrix}$$

$$= \begin{bmatrix} 8 & 12 \\ 3 & 5 \end{bmatrix} \cdot \begin{bmatrix} 60 & -30 \\ 52 & -26 \end{bmatrix} = \begin{bmatrix} 1104 & -312 \\ 440 & -220 \end{bmatrix}$$

b) 
$$\begin{bmatrix} 8 & 12 \\ 3 & 5 \end{bmatrix} \cdot \begin{bmatrix} 8 & 2 \\ 7 & 2 \end{bmatrix} - \begin{bmatrix} 8 & 2 \\ 7 & 2 \end{bmatrix} \cdot \begin{bmatrix} 8 & -4 \\ -2 & 1 \end{bmatrix}$$

$$\begin{bmatrix} 148 & 40 \\ 70 & 16 \end{bmatrix} - \begin{bmatrix} 60 & -30 \\ 52 & -26 \end{bmatrix} = \begin{bmatrix} 88 & 70 \\ 18 & 42 \end{bmatrix}$$

c) 
$$3 \begin{bmatrix} 8 & 12 \\ 3 & 5 \end{bmatrix} - \begin{bmatrix} 8 & 2 \\ 7 & 2 \end{bmatrix} + \begin{bmatrix} 8 & -4 \\ -2 & 1 \end{bmatrix}$$

$$\begin{bmatrix} 24 & 36 \\ 9 & 15 \end{bmatrix} - \begin{bmatrix} 8 & 2 \\ 7 & 2 \end{bmatrix} + \begin{bmatrix} 8 & -4 \\ -2 & 1 \end{bmatrix} = \begin{bmatrix} 24 & 30 \\ 0 & 14 \end{bmatrix}$$

4. a) Inverse is  $\frac{1}{4} \begin{bmatrix} 5 & -12 \\ -3 & 8 \end{bmatrix}$

b) Inverse is  $\frac{1}{2} \begin{bmatrix} 2 & -2 \\ 7 & 8 \end{bmatrix}$

c) Has no inverse since  $(8)(1) - (-2)(-4) = 0$

5. We already know that the multiplication of 2 X 2 matrices is associative - therefore the multiplication of 2 X 2 invertible matrices is associative. There is an identity element,  $I_2$ , such that

$$AI_2 = I_2A = A$$

Every element for every  $A$ ,  $A^{-1}$ .

To prove that the set of 2 X 2 invertible matrices, under multiplication, we need only show that the product of two invertible matrices is an invertible matrix. We did this in Exercise 8 of section 3.10.

Moreover, the inverse of  $AB$  is  $B^{-1}A^{-1}$

$$\begin{aligned} \text{for } (AB) \cdot (B^{-1}A^{-1}) &= A(B \cdot B^{-1})A^{-1} \\ &= AI_2A^{-1} \\ &= AA^{-1} \\ &= I_2 \end{aligned}$$

$$\begin{aligned} \text{also } (BA)(A^{-1}B^{-1}) &= B(A \cdot A^{-1})B^{-1} \\ &= BI_2B^{-1} \\ &= BB^{-1} \\ &= I_2 \end{aligned}$$

6. Let the left inverse  $E$  of  $D$  be  $D^{-1}$ .

Then  $E \cdot D = D^{-1}D = I_2$

But  $D \cdot E = D \cdot D^{-1} = I_2$

7. Let  $A = \begin{bmatrix} x_1 & y_1 \\ -y_1 & x_1 \end{bmatrix}$  and  $B = \begin{bmatrix} x_2 & y_2 \\ -y_2 & x_2 \end{bmatrix}$   
 $x_1, x_2, y_1, y_2 \in \mathbb{R}.$

Then  $A \cdot B = \begin{bmatrix} x_1 x_2 - y_1 y_2 & x_1 y_2 + y_1 x_2 \\ -y_1 x_2 - x_1 y_2 & -y_1 y_2 + x_1 x_2 \end{bmatrix}$

and  $B \cdot A = \begin{bmatrix} x_2 x_1 - y_2 y_1 & x_2 y_1 + y_2 y_1 \\ -y_2 x_1 - x_2 y_1 & -y_2 y_1 + x_2 x_1 \end{bmatrix}$

Comparing the elements of  $A \cdot B$  and  $B \cdot A$  and recalling the commutative properties of the real numbers we see that

$$A \cdot B = B \cdot A$$

## Chapter 4

### GRAPHS AND FUNCTIONS

Time Estimate: 15 - 18 days

In this chapter the concepts of graphing a function and graphing a condition in two variables are studied and the concepts unified. Graphs are used to extend the study of operations on functions, applications of functions, and properties of functions. It is hoped that after completing this picture the student will have a graphic picture in mind of the various concepts introduced in this chapter and will be able to operate with these concepts graphically and, to a lesser extent, algebraically.

An estimated time for the completion of the chapter is 15-18 class days.

#### 4.1 Conditions and Graphs ( $2\frac{1}{2}$ - 3 days)

We consider a condition to be an open sentence. A condition in two variables is an open sentence in two variables. In this chapter the domain of the variables is considered to be  $R$ , the real numbers. Such conditions may also be referred to as conditions on  $R \times R$ , and are denoted generally by  $C(x, y)$ .

Associated with  $C(x, y)$  is its solution set  $S = \{(x, y) : x \in R, y \in R, \text{ and } C(x, y) \text{ is true}\}$ . This set of ordered pairs then has a graph,  $T$ , where  $T$  is the set of points of the plane whose coordinates with respect to a coordinate system are the ordered pairs of  $S$ . We refer directly to  $T$  as the graph of  $C(x, y)$ . The coordinate system is standardized as a rectangular coordinate



system.

With this background in mind, the student should be led to recognize the relationship between equality, inequality, and absolute value conditions and the subsets of points of the plane which are their graphs.

In this section exploration of the relation between symmetry of graphs (sets of points in a coordinatized plane) and the conditions which determine them is begun. The following general definitions of symmetry of sets of points apply here and later.

Definition: If  $F$  is a set of points in a plane,

- (1)  $F$  is symmetric in line  $l$  (has line symmetry) if and only if  $F$  is its own image under the line reflection in  $l$ .
- (2)  $F$  is symmetric in point  $P$  (has point symmetry) if and only if  $F$  is its own image under the point reflection in  $P$ .

Exercise 6 of 4.2 is essential to future development.

Problems 1 and 2 could be done in class.

All problems in 3 and 5 need not be assigned.

4.2 Exercises

1. (a) - (d)

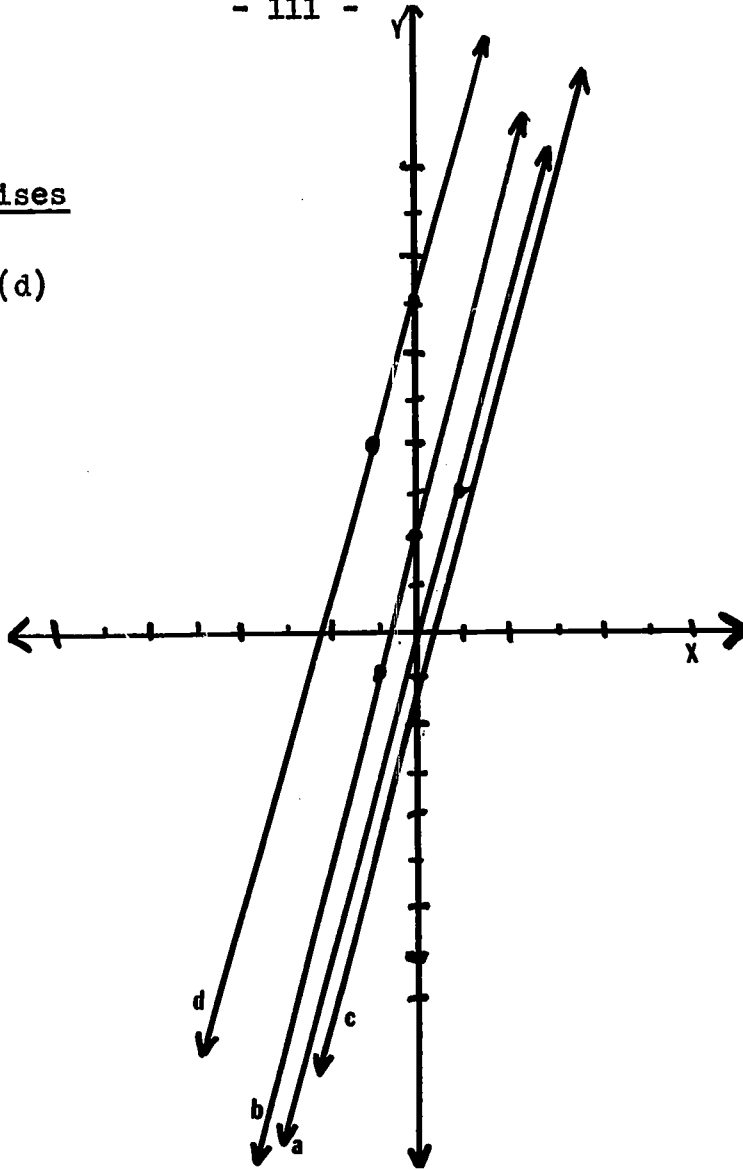

(e) All the graphs have a slope of 3.

(f) The slope.

2. (a) - (d)

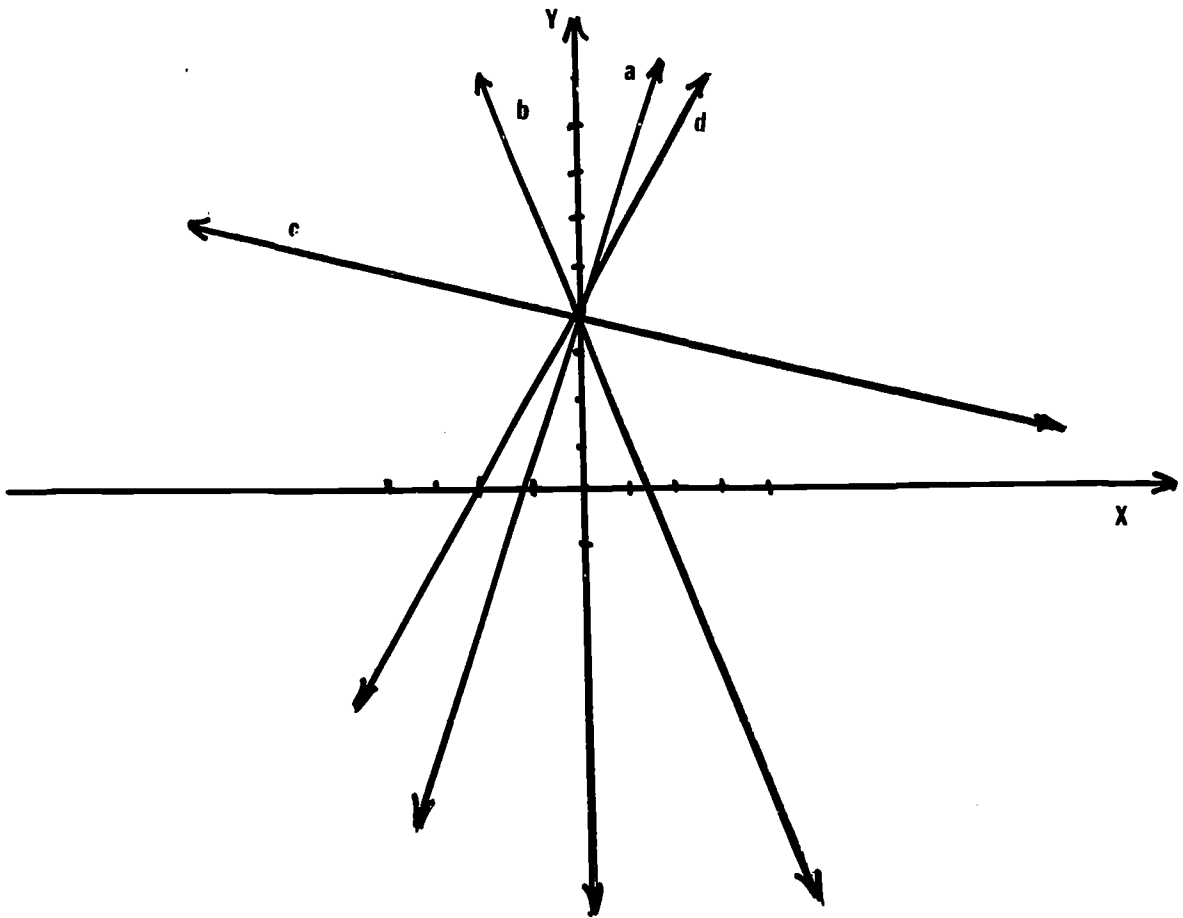

(e) All lines intersect at  $(0, 4)$ .

(f) The y intercept. The line intersects the y axis at  $(0, b)$ .

3.

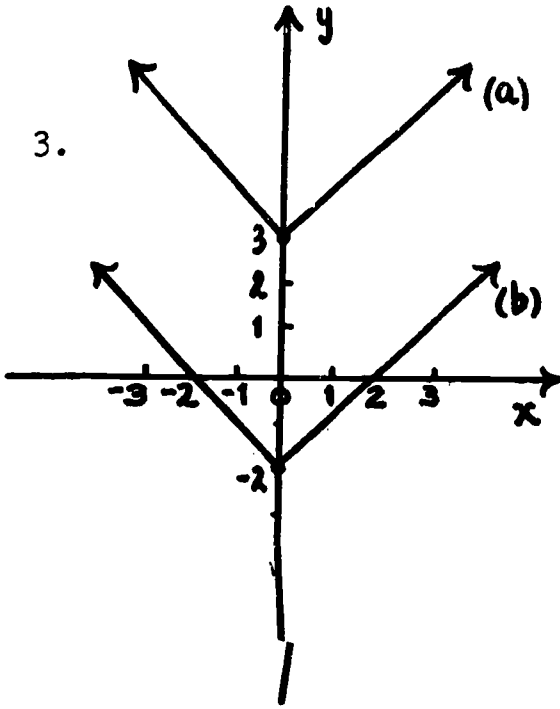

Both are symmetric with respect to the y - axis.

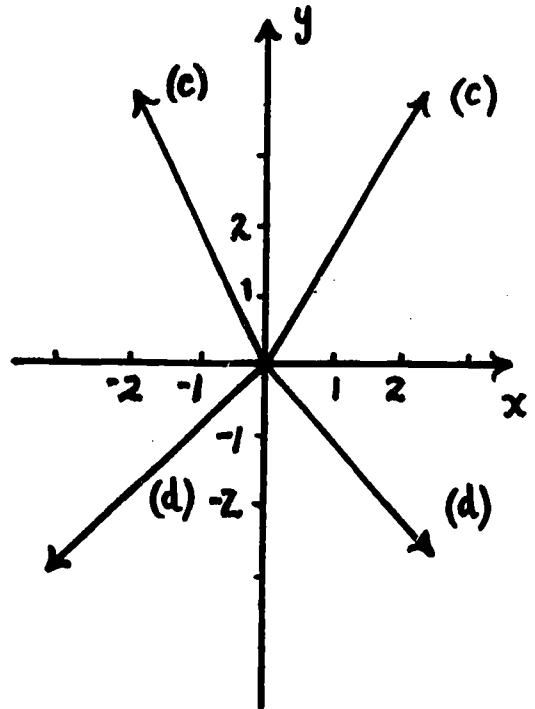

Both are symmetric with respect to the y - axis.

(e) Same as (c)

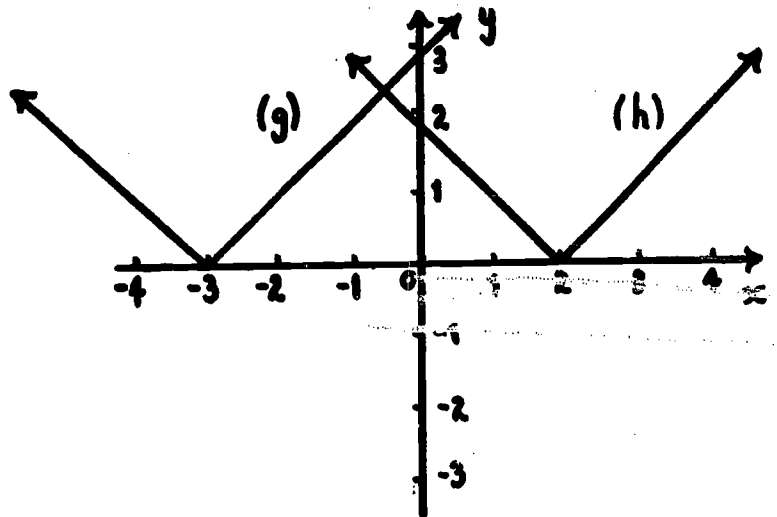
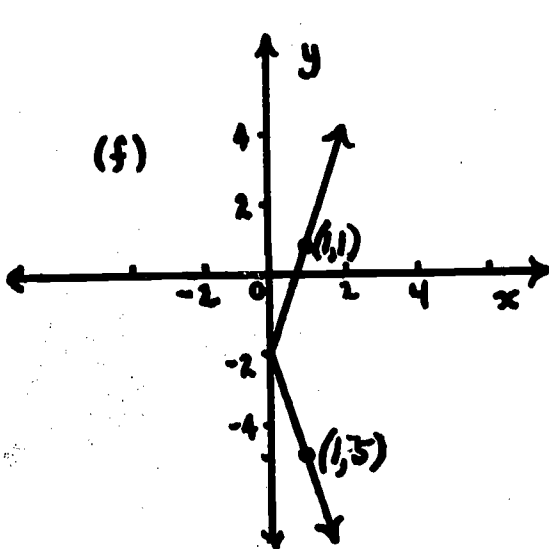

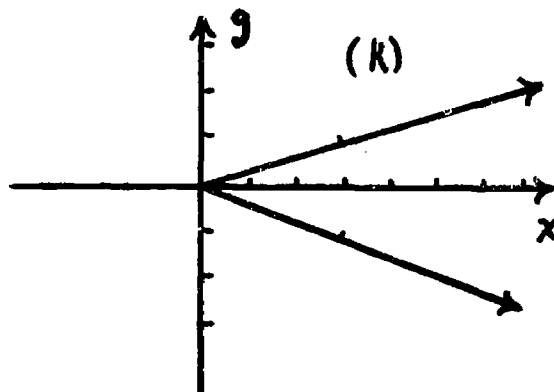
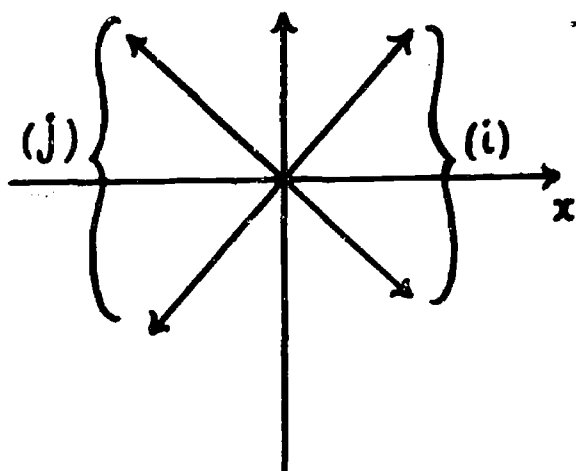

i) Symmetric with respect to x - axis.

Symmetric with respect to x - axis.

j) Symmetric with respect to x - axis.

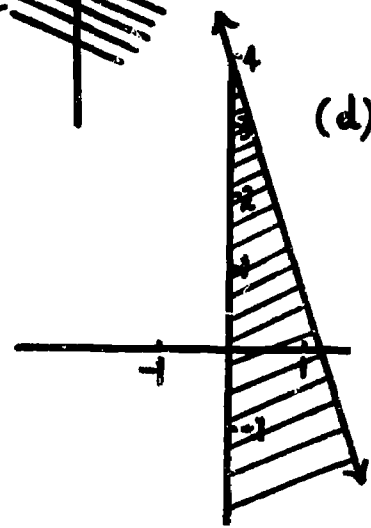
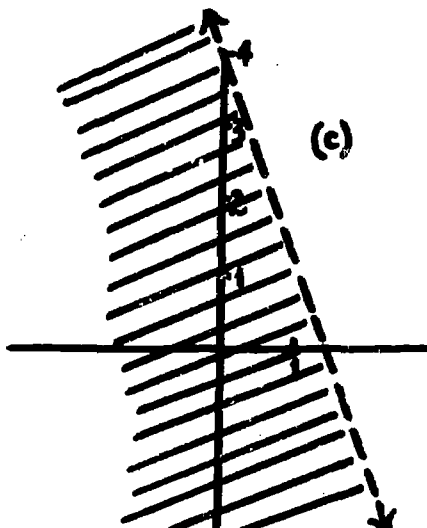
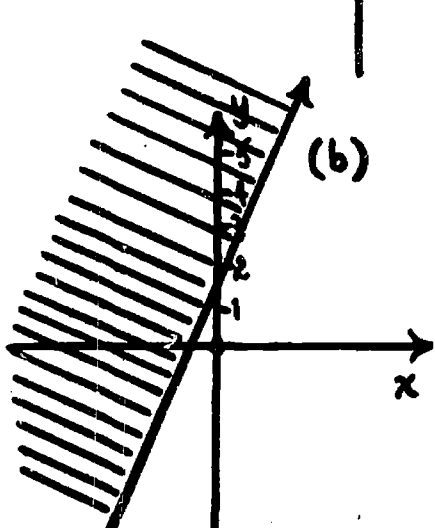
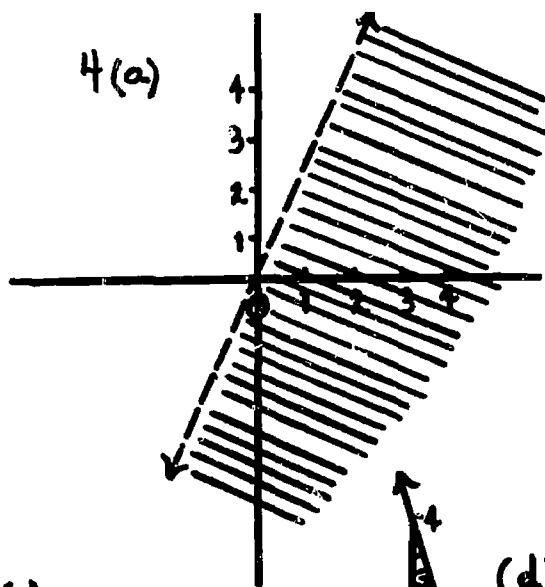
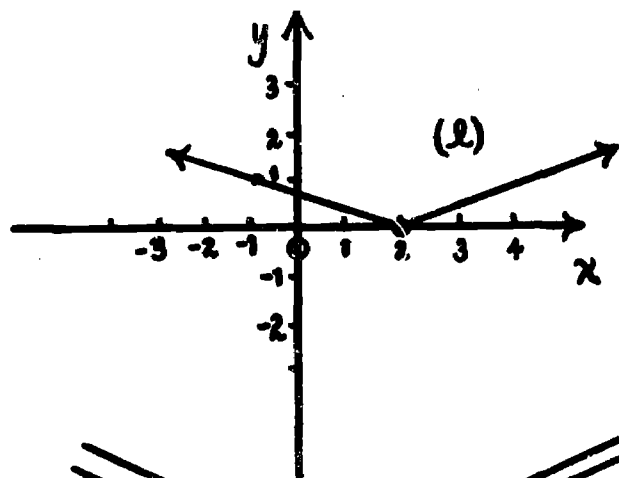

(e) Triangle is bounded by  $x = 0$ ,  $y = 0$  and  $y = -3x + 4$  in exercise 4(d).

5. (a)

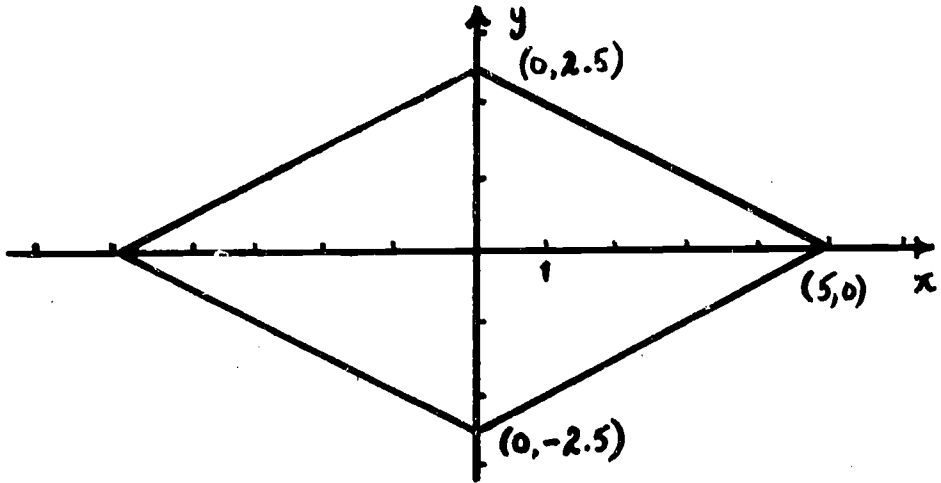

(b)

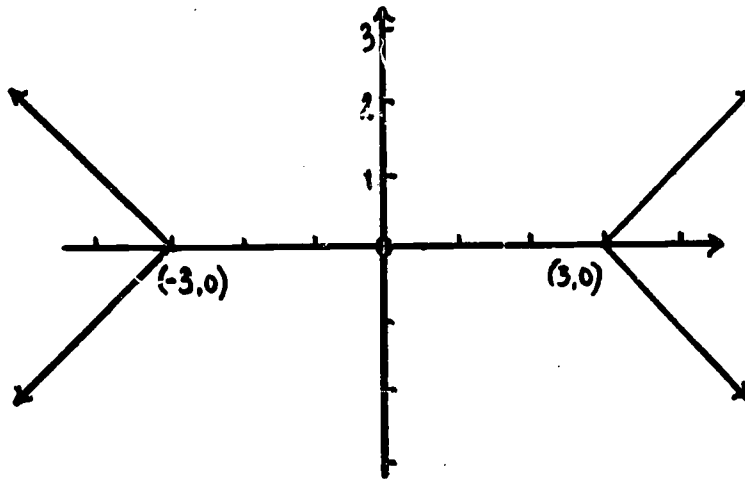

(c)

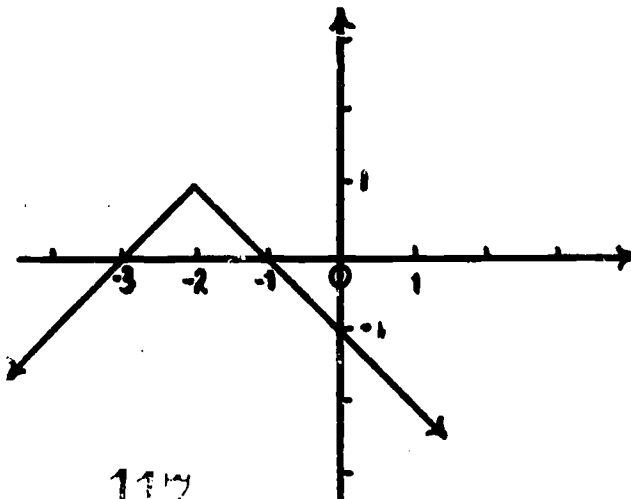

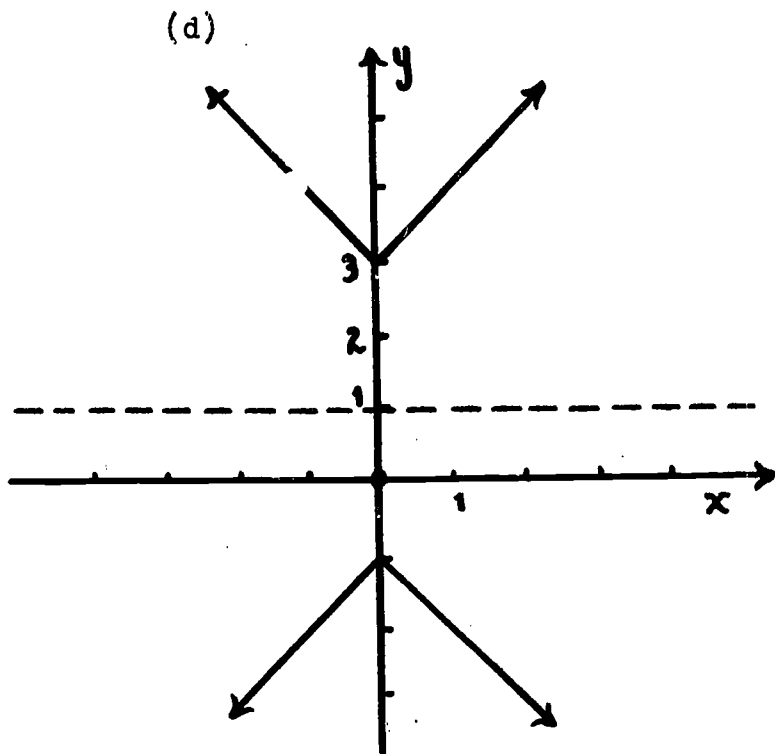

$$\begin{aligned}
 &x \geq 0, y \geq 1 \\
 &x - y + 1 = -2 \\
 &y = x + 3 \\
 &x \leq 0, y \geq 1 \\
 &-x - y + 1 = -2 \\
 &y = -x + 3 \\
 &x \leq 0, y \leq 1 \\
 &-x + y - 1 = -2 \\
 &y = x - 1 \\
 &x \geq 0, y \leq 1 \\
 &x + y - 1 = -2 \\
 &y = -x - 1
 \end{aligned}$$

(e)  $x + 2y = 4$  or  $x + 2y = -4$

$$2y = -x + 4 \text{ or } 2y = -x - 4$$

$$y = -\frac{1}{2}x + \frac{4}{2} \text{ or } y = -\frac{1}{2}x - \frac{4}{2} \text{ or } y = -\frac{1}{2}x - 2$$

The graph is a pair of parallel lines of slope  $-\frac{1}{2}$ . One line has  $y$ -intercept 2, the other -2.

(f)  $2y = |x| + x$

$$y = \frac{1}{2}|x| + \frac{1}{2}x$$

$$y = \frac{1}{2}x + \frac{1}{2}x = x$$

if  $x \geq 0$

$$y = -\frac{1}{2}x + \frac{1}{2}x = 0$$

if  $x < 0$

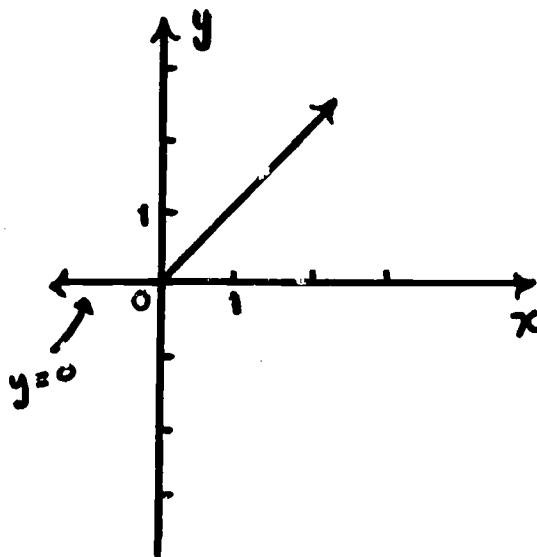

(g)

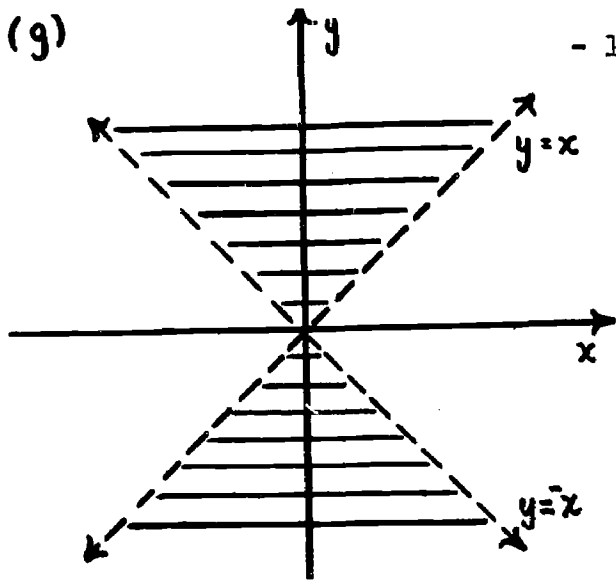

- 117 - (h)

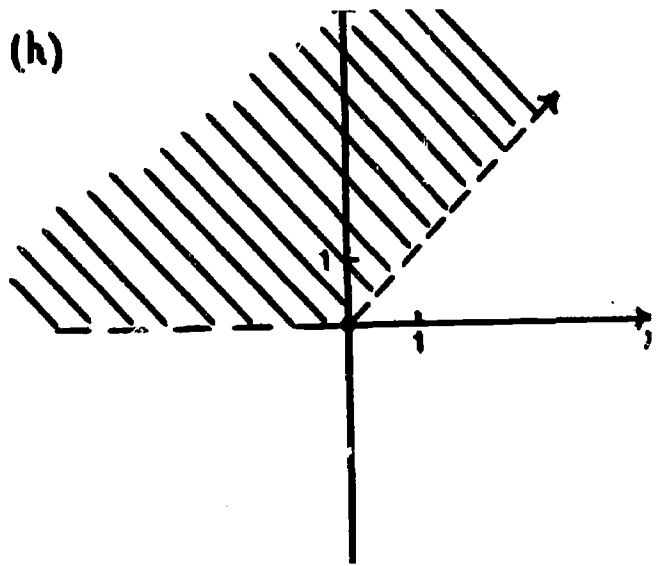

6. (a) Yes. No.

(b)  $C(x, y)$  if  $(-x, -y)$ .

(c) Yes.

7. (a) Symmetries (1), (2), (3), and (4).

(b) Symmetries (1), (2), and (3).

(c) Symmetries (2).

(d) Symmetries (3), (4).

8. (a)

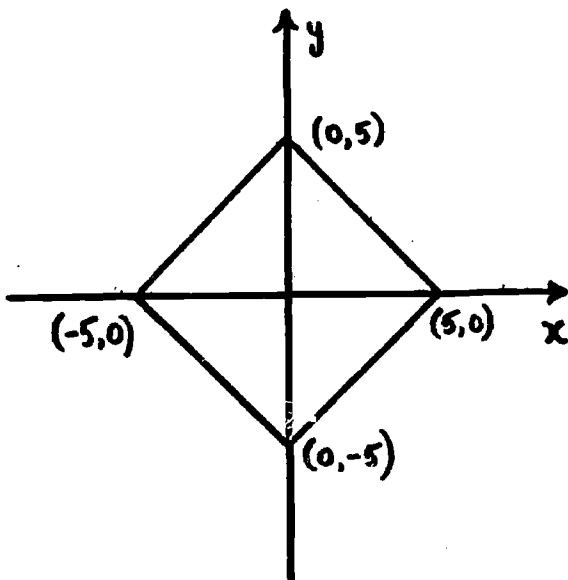

(b)

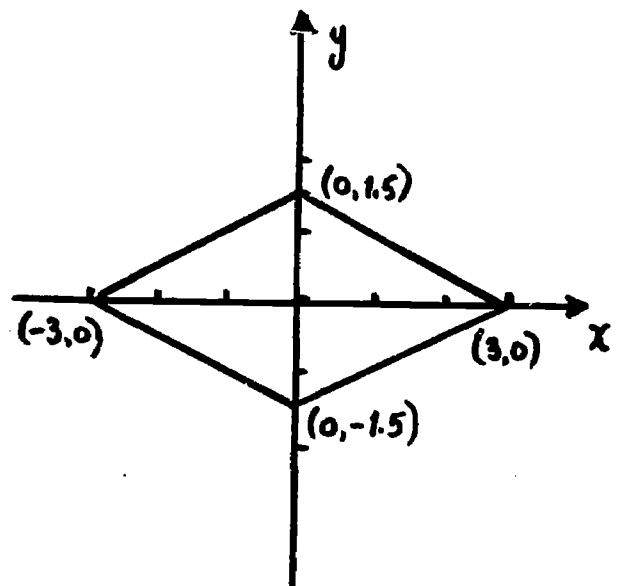



(c)

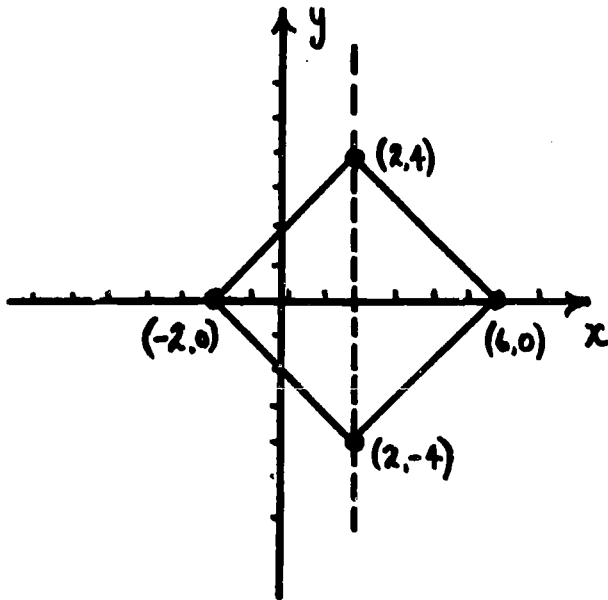

(d)

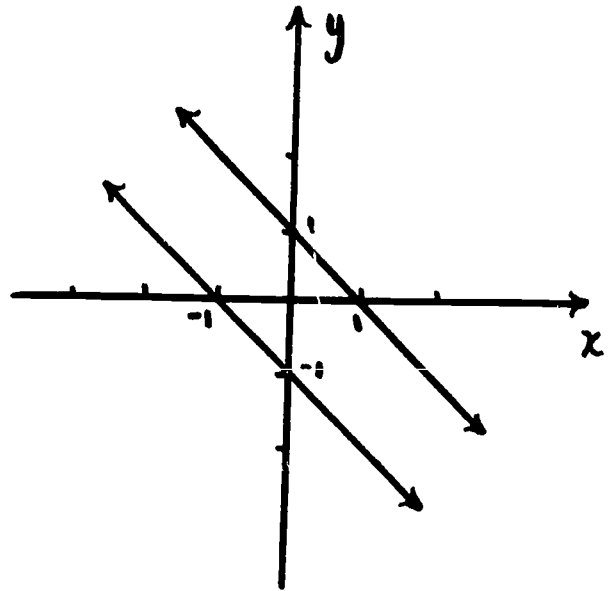

$$x + y = 1 \text{ or } x + y = -1$$

$$y = -x + 1$$

$$\text{or } y = -x - 1$$

#### 4.3 Regions of the Plane and Translations (2 - 2 $\frac{1}{2}$ days)

The main idea of this chapter is embodied in Figure 4.8. In many traditional texts, the emphasis is on change of coordinates by a translation but here we emphasize that since a translation is an isometry, the region and its image under a translation are congruent.

The student should gain the insight that the graph of  $C'(x + a, y + b)$  is the image of the graph of  $C(x, y)$  under the translation  $(x, y) \xrightarrow{T} (x - a, y - b)$ . Note the change in sign.

For example, consider the graph of  $|x - 5| + |y - 3| = 2$ , Example 2 in the text. There it is noted that the graph  $G'$  of  $|x - 5| + |y - 3| = 2$  is the image of the graph  $G$  of  $|x| + |y| = 2$  under  $(x, y) \xrightarrow{T} (x + 5, y + 3)$ . But we can also consider the graph  $G'$  of  $|x - 5| + |y - 3| = 2$  to be the graph of  $|x'| + |y'| = 2$  where  $x'$  and  $y'$  are the coordinates of points of  $G'$  if new  $x'$  and  $y'$  axes are chosen with origin at  $(5, 3)$  and axes parallel to the  $x$  and  $y$  axes. Thus, if a point has coordinates  $(a, b)$  in the  $x, y$  coordinate system it has coordinates  $(a - 5, b - 3)$  in the  $x', y'$  coordinate system. If a point has coordinates  $(a', b')$  in the  $x', y'$  coordinate system, it has coordinates  $(a' + 5, b' + 3)$  in the  $x, y$  coordinate system.

However, because of the students' familiarity with translations as isometries the point of view here is to treat the properties of a region in terms of an isometric region lying conveniently with respect to a given  $x, y$  coordinate system. In other words, the coordinate system is fixed.

4.4 Exercises

1. (a)

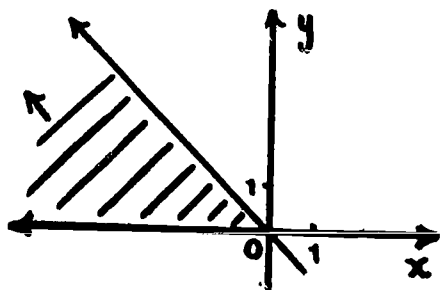

(b)

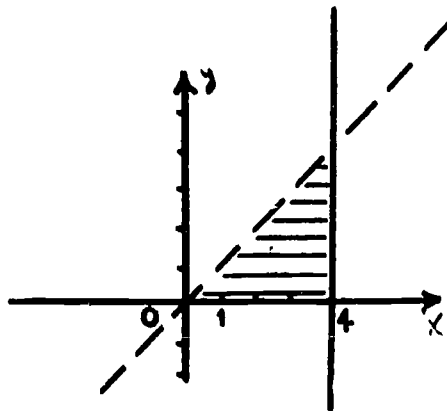

(c)

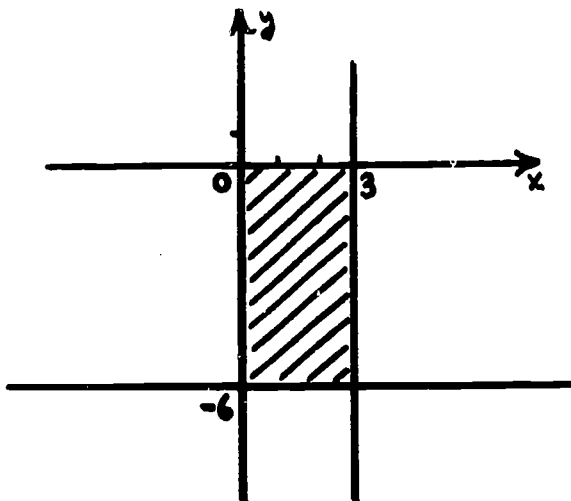

(d)

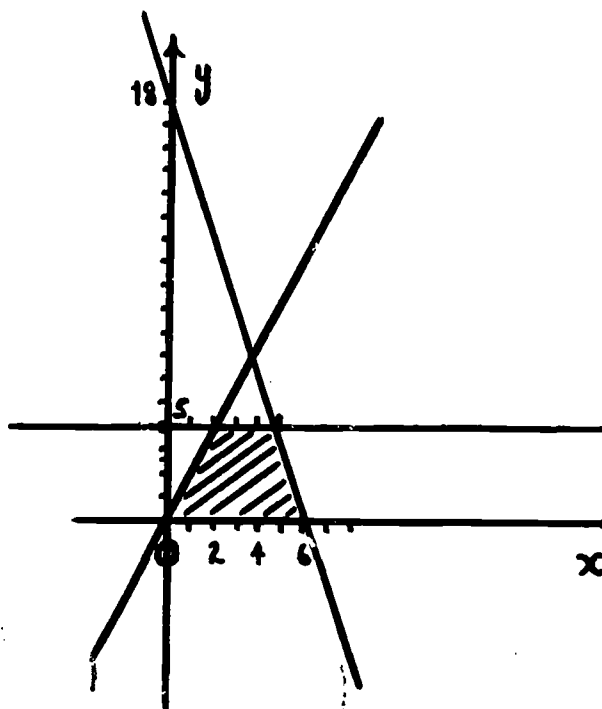

(e)

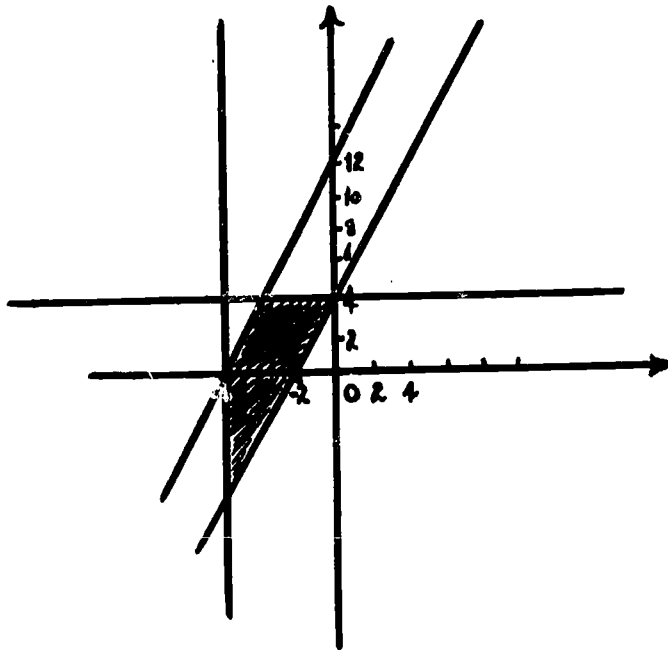

2. (a)

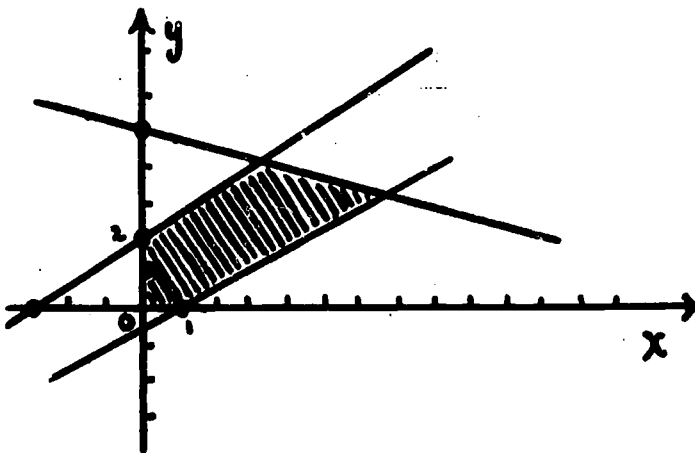

(b)

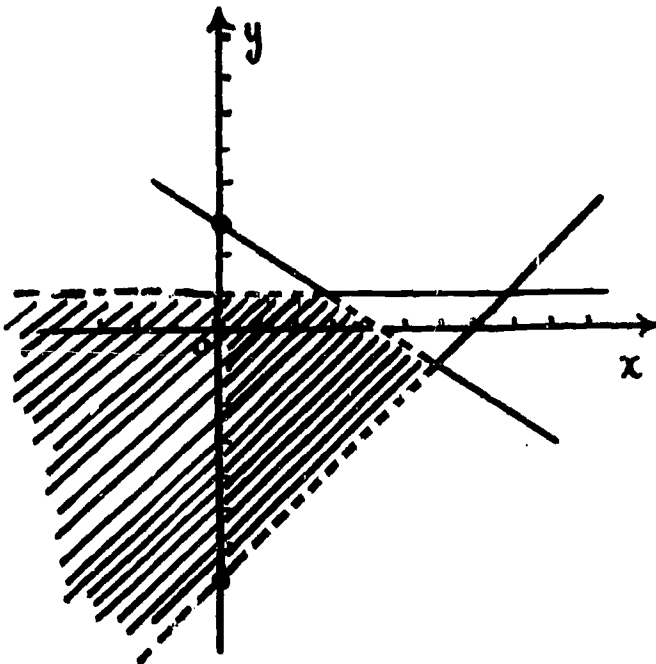

(c)  $x < 0$  or  $3y - 2x > 6$  or  $5y - 3x < -3$  or  $4y + x > 20$   
or  $y < 0$ . (any correct equivalent)

(d)  $3y + 2x \geq 9$  or  $y \geq 1$  or  $y \leq x - 7$ .  
(any equivalent form)

3. (a)

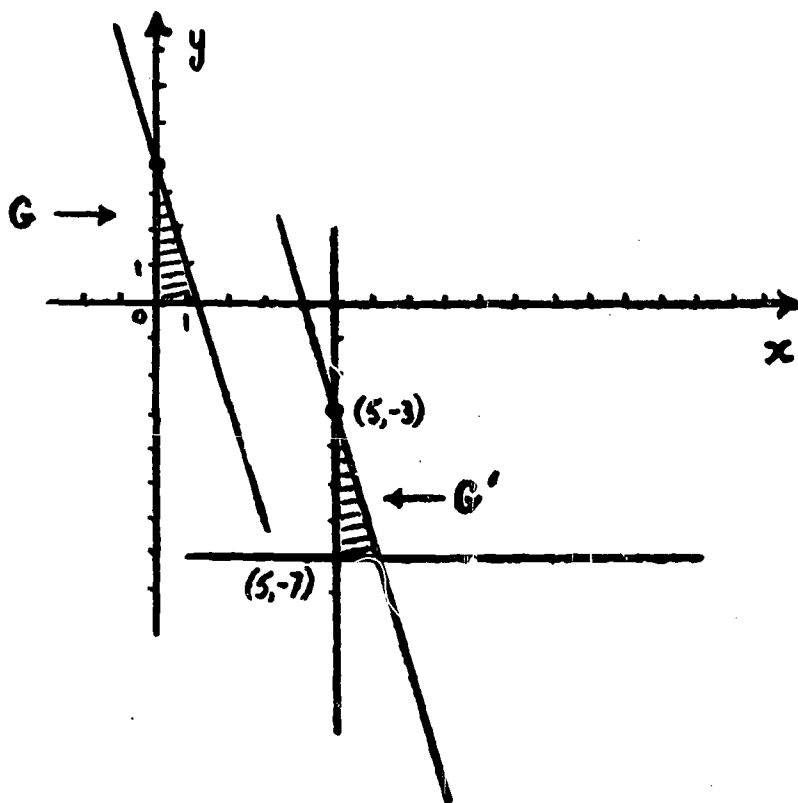

(b)  $y + 3 \geq -3(x - 5)$  and  $x - 5 \geq 0$  and  $y \geq -7$ .

(or equivalent form)  $y + 7 \leq -3(x - 5) + 4$  and

$x - 5 \geq 0$  and  $y + 7 \geq 0$

4. (a) - (c)

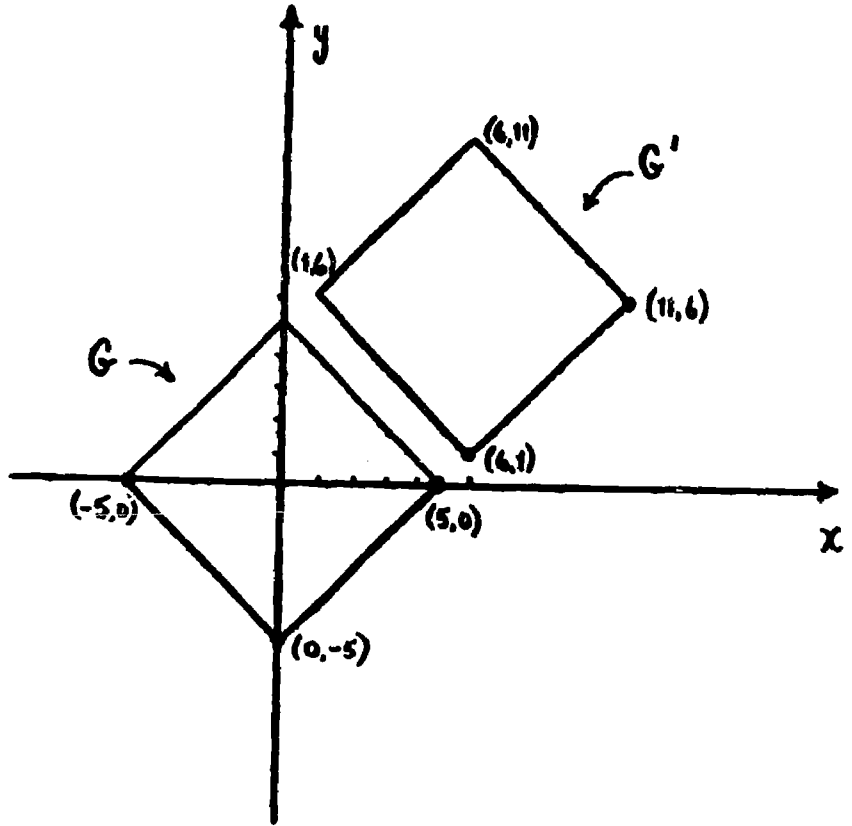

5. (a) - (b)

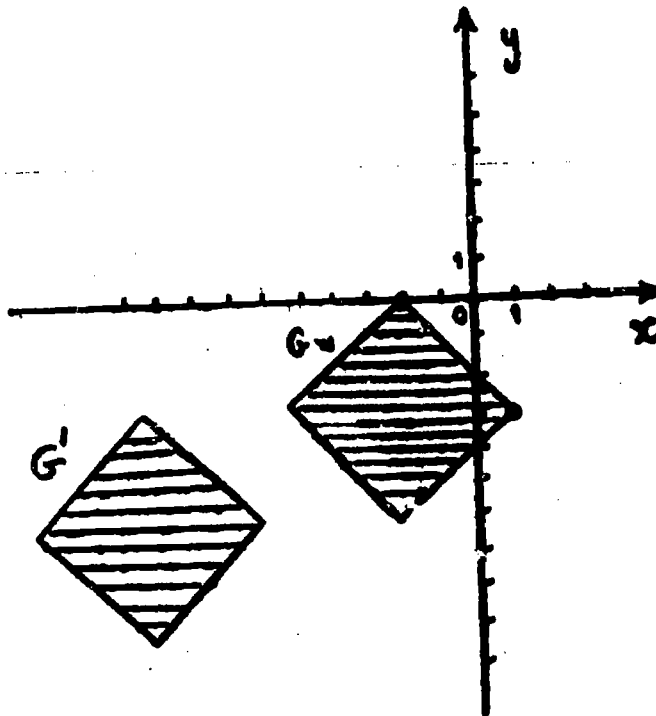

(c)  $|x + 9| + |y + 6| \leq 3$

6. (a), (b)

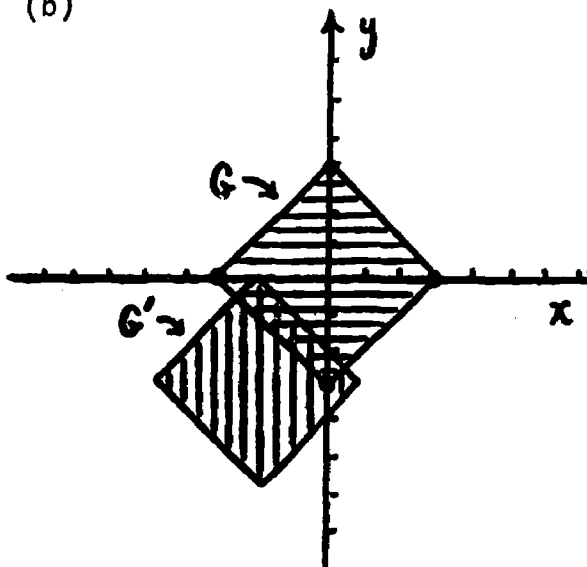

7. (a)

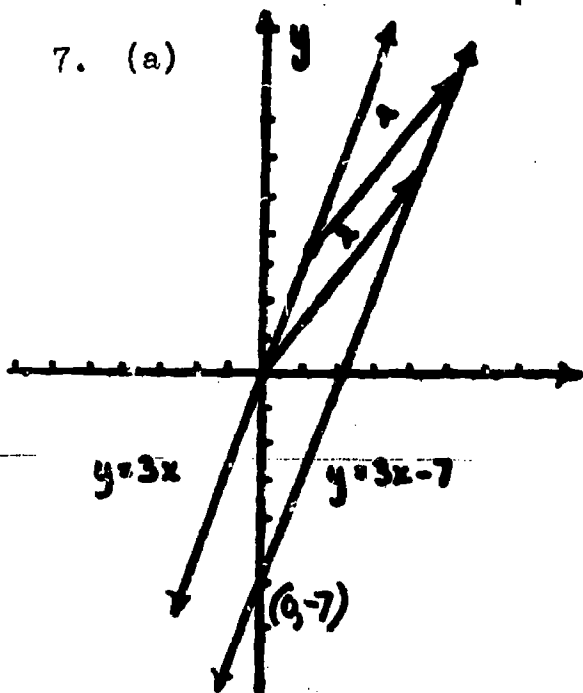

$(y - 5) = 3(x - 4)$

if  $y = 3x - 7$

- (b) Translations map lines onto parallel lines.
- (c) 3
- (d) Yes, because any line with slope 3 is parallel to  $y = 3x$  and differs only in its intercept. If  $b$  is the  $y$ -intercept, i.e.,  $y = 3x + b$  is the line, then the translation  $T_{O,b}$  will map  $y = 3x$  onto  $y = 3x + b$



4.5 Functions and Conditions ( $1\frac{1}{2}$  - 2 days)

The following points are central to the development of this section.

- (1) A real function  $f: A \longrightarrow B$  determines a set of ordered pairs  $\{(x, f(x)) : x \xrightarrow{f} f(x) \text{ and } x \in A\}$  and this set of ordered pairs determines the function  $f$ . From the ordered pairs or their graph the assignments  $x \xrightarrow{f} f(x)$  can be recovered. Thus, this set of ordered pairs may be called the set of ordered pairs of  $f$ .
- (2) Associated with  $f$  is the equation  $y = f(x)$ , called an associated function equation. The solution set of this equation as a condition in  $x$  and  $y$  may or may not be the set of ordered pairs of  $f$ . The condition  $y = f(x)$  and  $x \in A$  has as solution set the set of ordered pairs of  $f$ . Graphing a function then becomes equivalent to graphing a condition. The solution set of  $y = f(x)$  and  $x \in A$  thus also determine the function of  $f$ .
- (3) A set of ordered pairs may determine a function only if no two pairs have the same first element (for the graph, the vertical line test holds).
- (4) Any condition  $C(x, y)$  potentially determines a function. The solution set of  $C(x, y)$  must satisfy (3) above in order to determine a function. However, even if this is true,  $C(x, y)$  in itself uniquely

determine a function unless the codomain is specified.

In dealing with each of these ideas emphasis should be placed on specifying the domain and in the properties of the ordered pairs and their graph. Codomain should be discussed but it is not a central issue here. If, as is noted,  $\mathbb{R}$  is taken as a standard codomain,  $y = f(x)$  and  $x \in A$  completely determines a function, as does any function condition.

The treatment of symmetry should be handled with reference to  $y = f(x)$  as a condition in  $x$  and  $y$  and with strong reference to the graph itself.

The greatest integer function is introduced here as a special function so that it is available for use in examples and exercises later on.

Note that  $x \in [a, b]$  means that  $a \leq x \leq b$ :  $x \in \mathbb{R}$ .

#### 4.6 Exercises

1. (a)  $y = 1 + x^2$  (d)  $y = \frac{|x|}{1 + x^2}$   
(b)  $y = |x|$  (e)  $y = 3x + 5$   
(c)  $y = \frac{1}{x}$
2. (a) Yes. Graph is a line. Vertical line test holds.  
(b) Yes. No two ordered pairs have the same first element.  
(c) Yes. No two ordered pairs have the same first element.  
(d) Yes. Same reason.  
(e)  $|y| = x$ . No. For  $x = 3$ ,  $y = \pm 3$ .  
(f) No. Graph is a pair of parallel lines:  $x + y = 7$ ,  
 $x + y = -7$ .

- (g) No. Vertical lines test fails. Also, no ordered pair exists for  $x = 23$ .
- (h) No. For  $x = 3$ ,  $y = \pm 1$ .
- (i) No. For  $x > 1$ ,  $y$  is imaginary number and thus not in standard codomain  $\mathbb{R}$ .
- (j) No. For  $x = 1$ ,  $y = \pm 216$ .

2. (a)  $y = 2x - 7$ ,  $x \in \mathbb{R}$  (b)

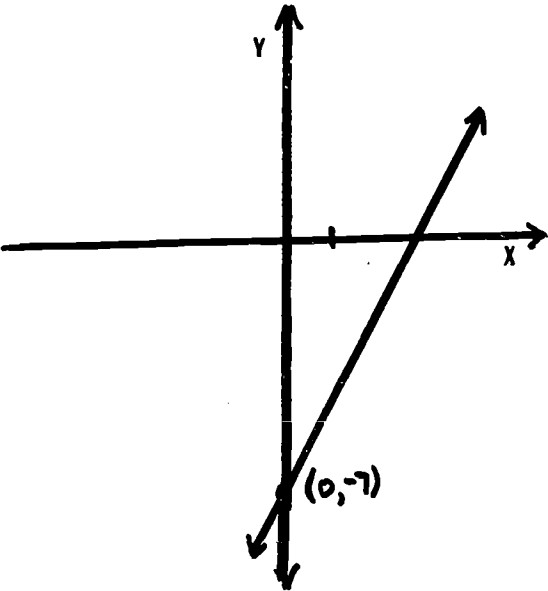

(c)

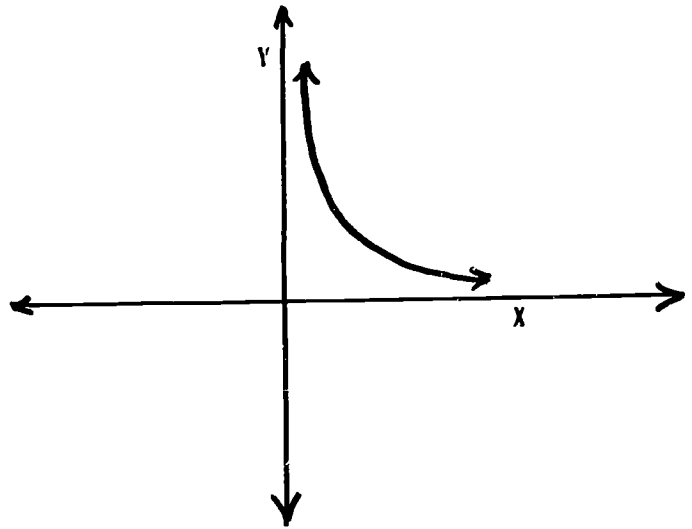

(d)

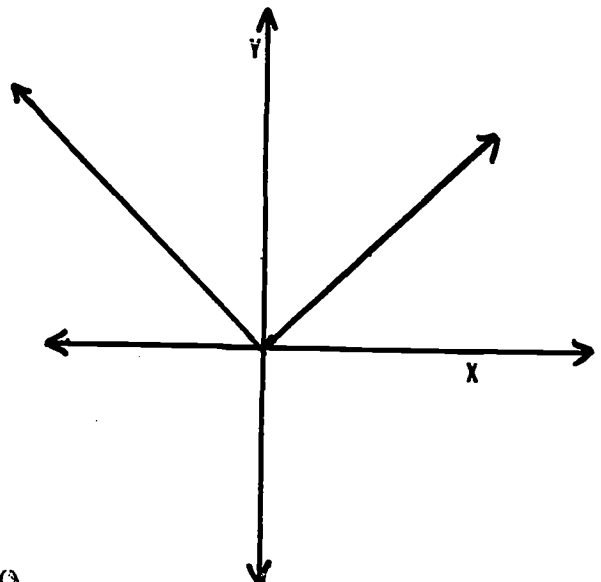
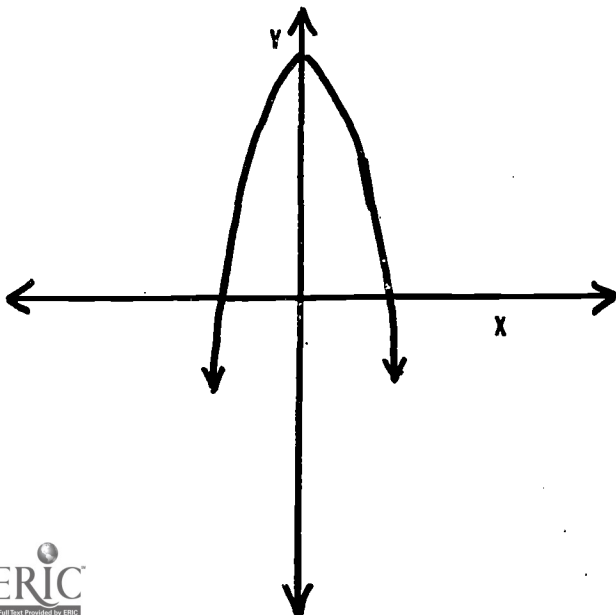

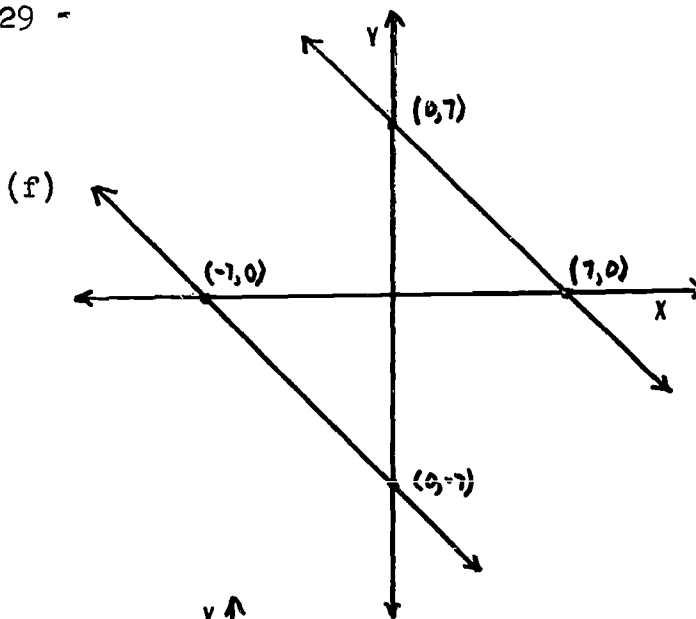
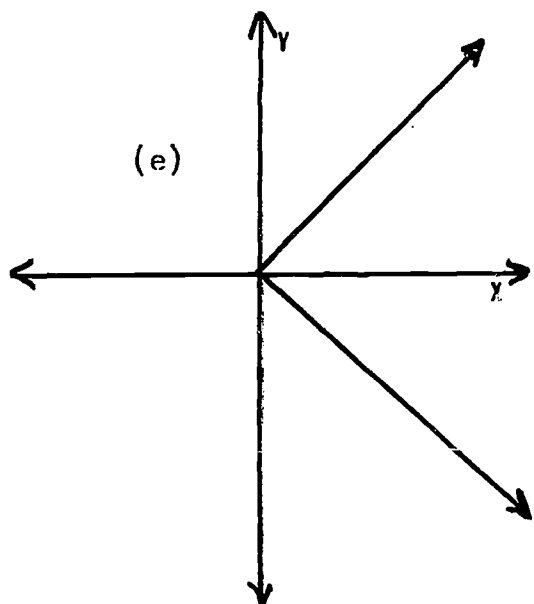

(g)  $|x| + |y| = 17 \quad x \in \mathbb{R}$

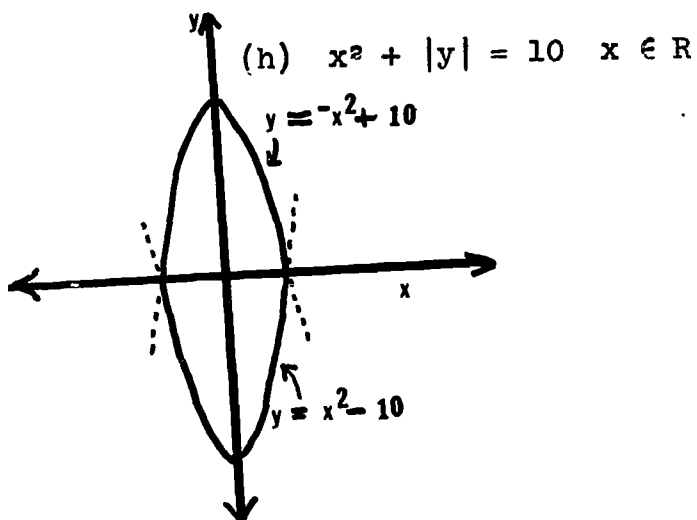
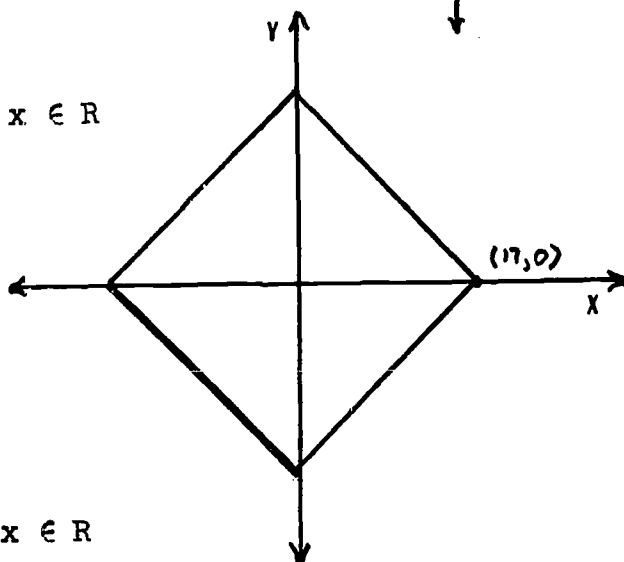

(i) For  $x > 1$ ,  $y$  is imaginary  $\therefore$  no graph.

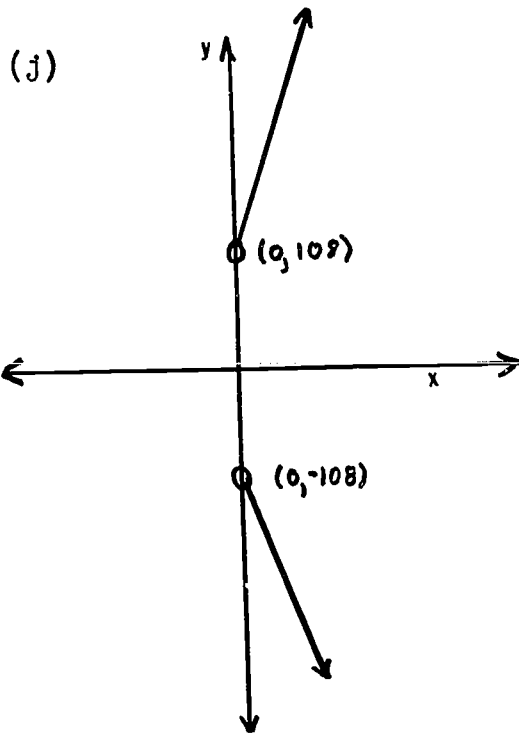

3. (a) Symmetry in y - axis.  
 (b) None  
 (c) Symmetry in origin  
 (d) Symmetry in origin

- (e) None  
 (f) None  
 (g) Symmetry in origin  
 (h) Symmetry in y - axis

4. (a)

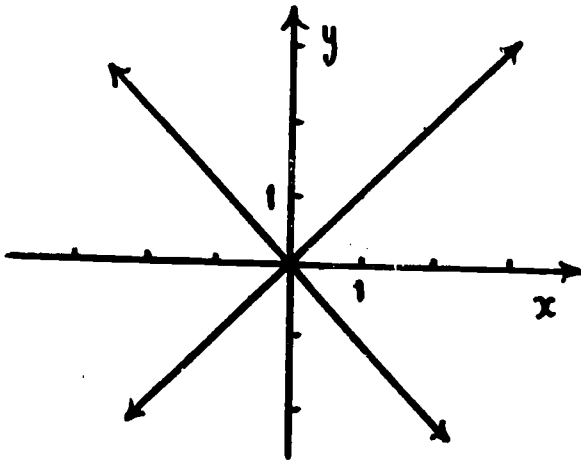

No. Vertical line test.

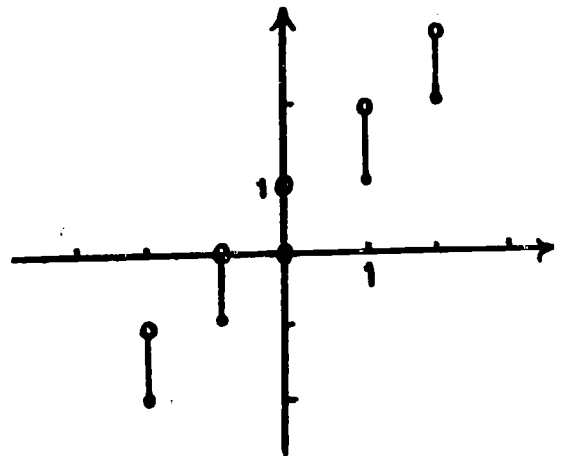

No.  $1 \rightarrow 1, 1 \rightarrow 1\frac{1}{2}$

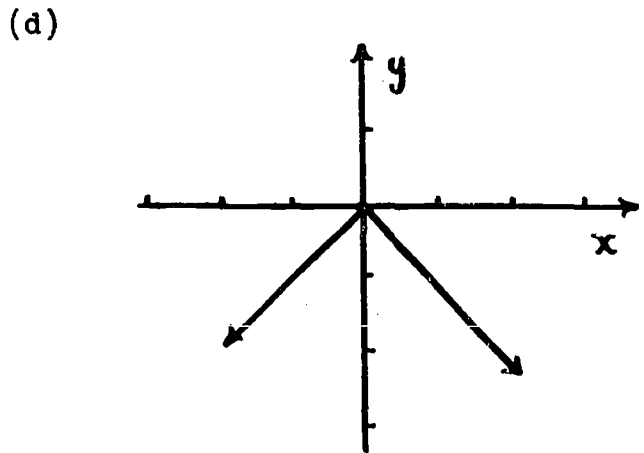
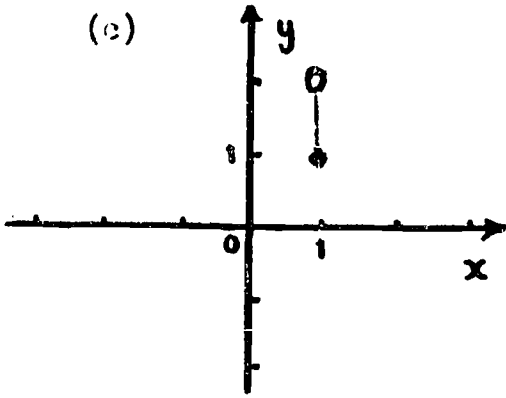

Graph is the single point  
(1, 1). Yes. Domain = {1}.

Yes. Vertical line test holds.

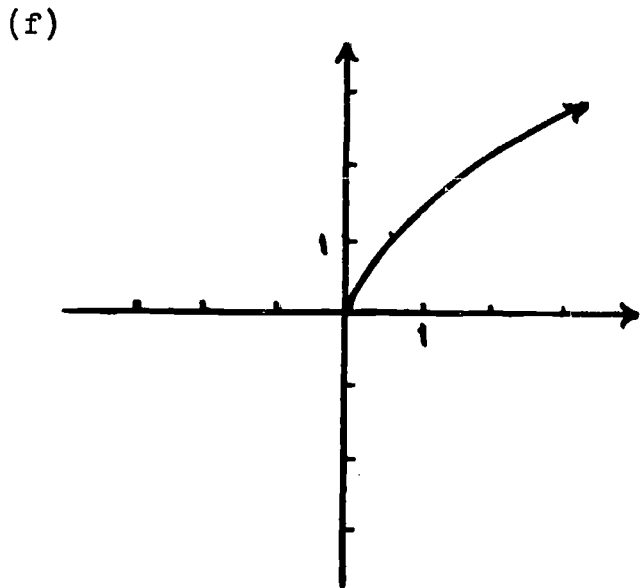
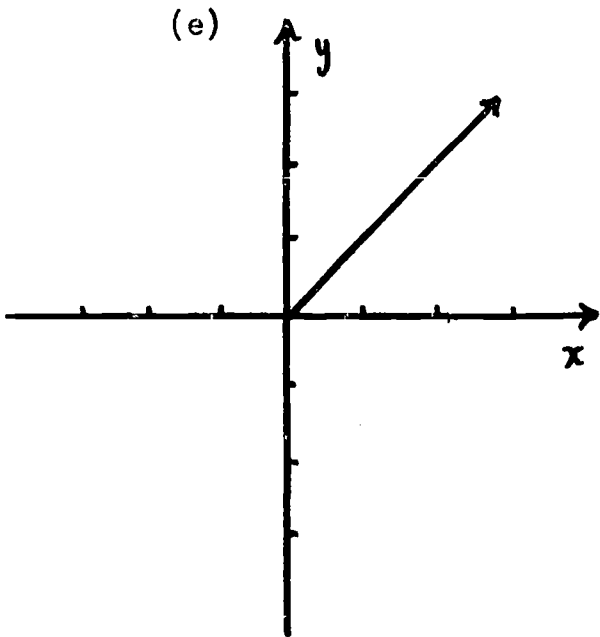

Yes. Vertical line test  
holds.

Yes.

(g)

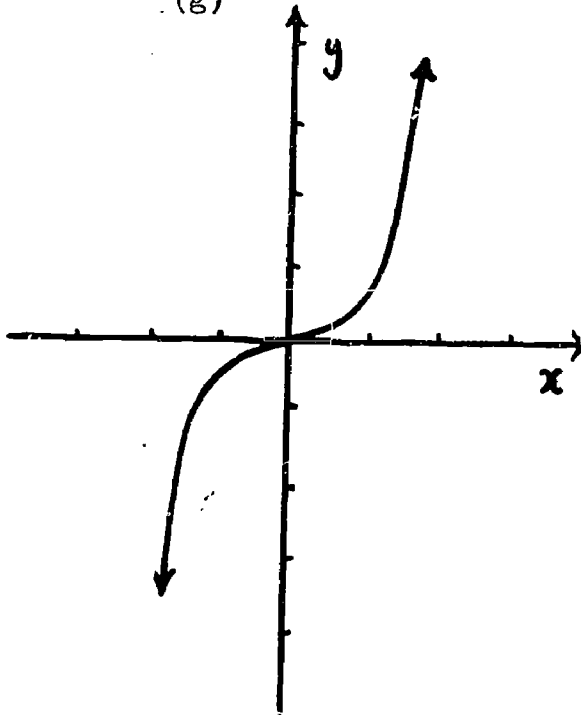

Yes.

(h)

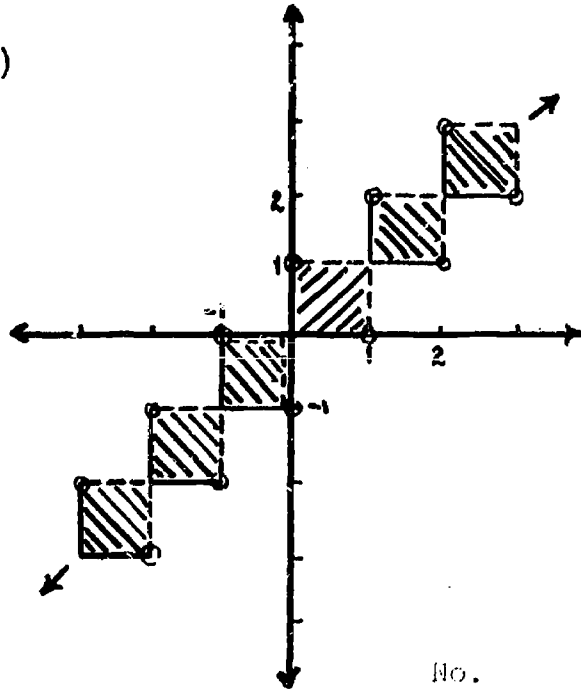

No.

No. Vertical line test fails.

#### 4.7 Functions and Solution of Equations ( $1\frac{1}{2}$ - 2 days)

The fundamental aim of this section is to tie together the work involving graphing of functions, graphing of conditions, and the solution of equations. Whenever possible, try to show how several equations or systems of equations can be solved using a single graph of function in terms of "a - points" or **zero - points**.

In using graphs, the fact that only approximate solutions are obtained should be discussed and how, practically, the approximations can be made more precise.

The space - time examples provide a practical application of these techniques and are generalized somewhat in the exercises.

Other typical "verbal problems" that appear in the usual elementary algebra text such as "mixture" problems may be solved by similar graphic techniques.

Exercises 4 and 5 should be done completely and as many parts of Exercise 6 as are deemed necessary.

#### 4.8 Exercises

1. (a) 200 miles (d) Yes  
(b) 200 miles (e) 200 mph,  $66\frac{2}{3}$  mph,  
(c)  $2\frac{1}{2}$  hours  $133\frac{1}{3}$  mph.  
(f) Wind, gaining attitude, losing attitude, etc.
2. (a) 125 miles (b) (4.6, 600)  
(a) { (b) 200 miles No  
(c) 3 hours (c) Yes. No explanation  
needed.
3. The plane in f started 400 miles from the base and travelled for 8 hours, while the plane in g starts from the base but 2 hours later than f and travels 6 hours.



4.

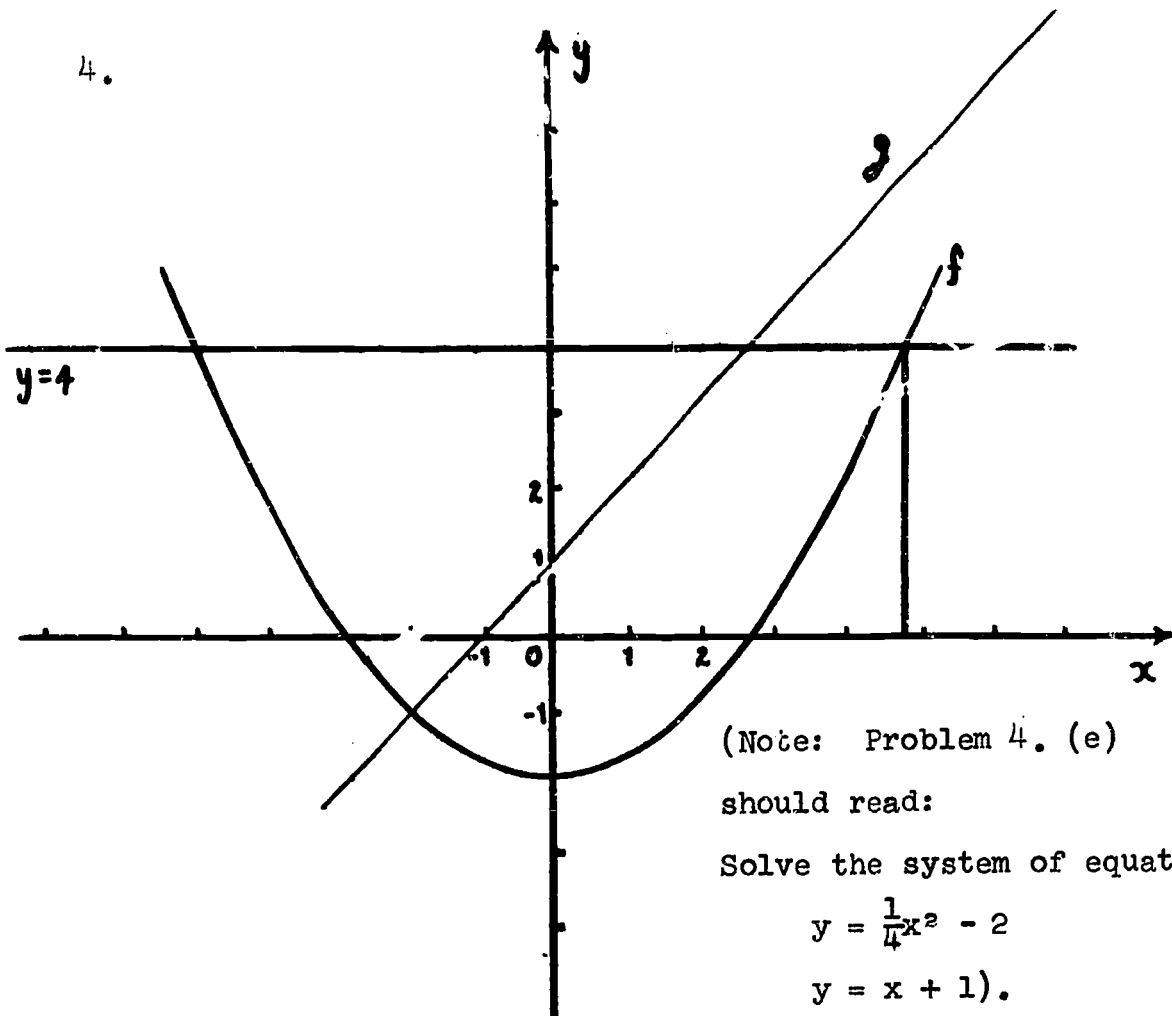

(Note: Problem 4. (e) should read:

Solve the system of equations

$$y = \frac{1}{4}x^2 - 2$$

$$y = x + 1).$$

(a) \_\_\_\_\_

(b) approximately  $(-2.8, 0)$   
 $(2.8, 0)$

(c)  $(-1, 0)$

(d)  $\{-4.8, 4.8\}$

(e)  $\{(-2, 1), (6, 7)\}$

These are the coordinates of the points where the graphs intersect.

5. (a)  $x \xrightarrow{f} -\frac{3}{2}x + \frac{7}{2}$

(b)  $x, 6\frac{1}{4}$

$x \xrightarrow{g} \frac{1}{2}x - 9$

(c)  $(6\frac{1}{4}, -5\frac{7}{8})$

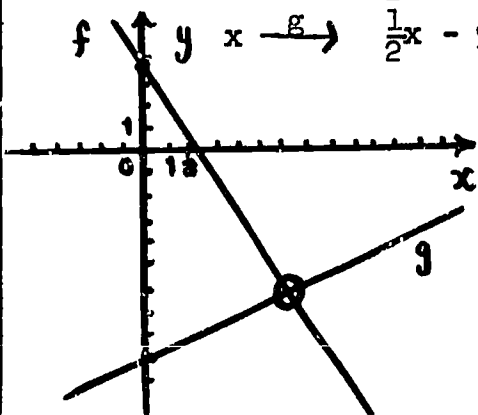

6. (a)  $x \xrightarrow{f} -\frac{1}{2}x + 2$

$x \xrightarrow{g} \frac{2}{2}x - 3$

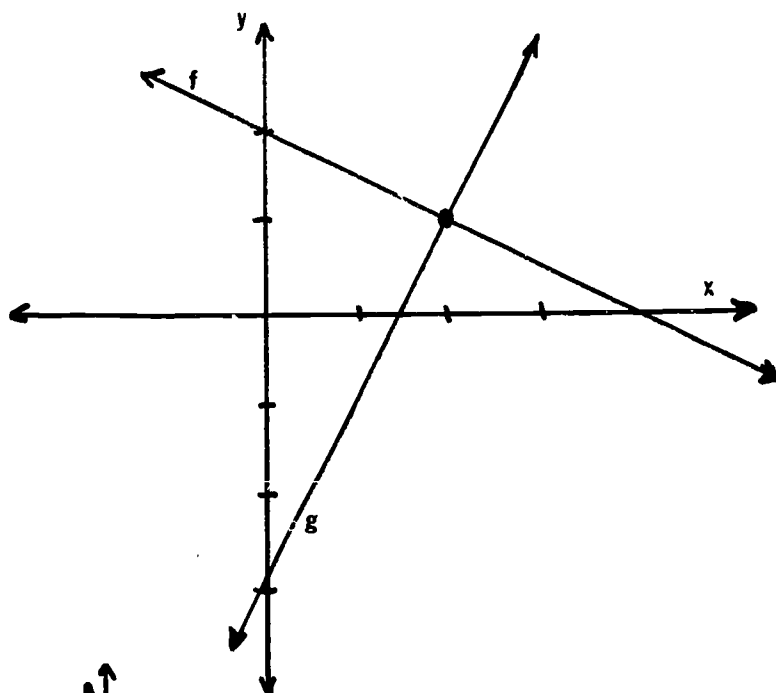

$x = 2$

$(2, 1)$

(b)  $x \xrightarrow{f} -5x + 10$

$x \xrightarrow{g} 4 - x$

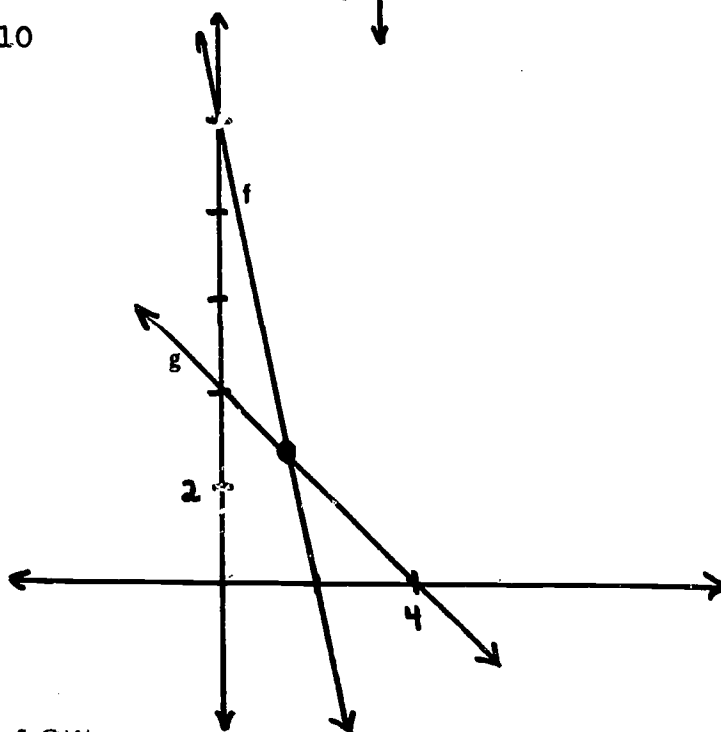

$x = 1.5$

$(1.5, 2.5)$

(c)  $x \xrightarrow{f} -\frac{2}{3}x + \frac{10}{3}$   
 $x \xrightarrow{g} -\frac{2}{3}x + \frac{20}{3}$

No solution. The graphs show parallel lines.

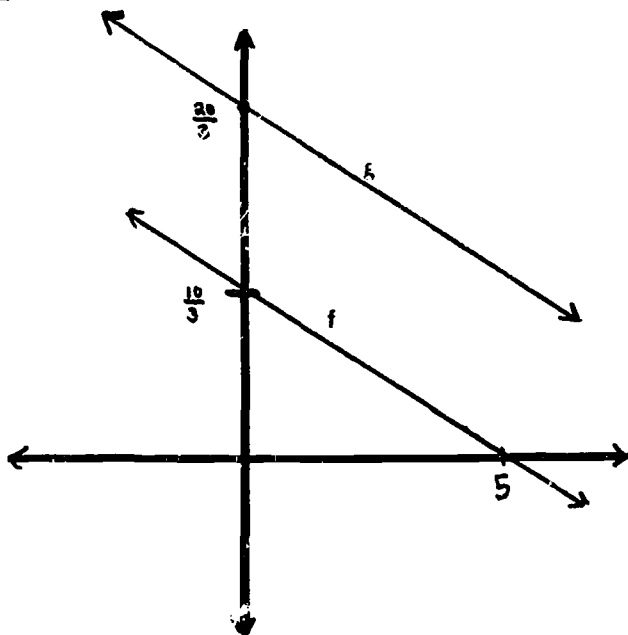

(d)  $x \xrightarrow{f} \frac{1}{3}x - \frac{17}{3}$   
 $x \xrightarrow{g} \frac{1}{3}x - \frac{17}{3}$

The graphs are the same line. Therefore all values of  $x$  that satisfies  $f(x)$  satisfies  $g(x)$ .

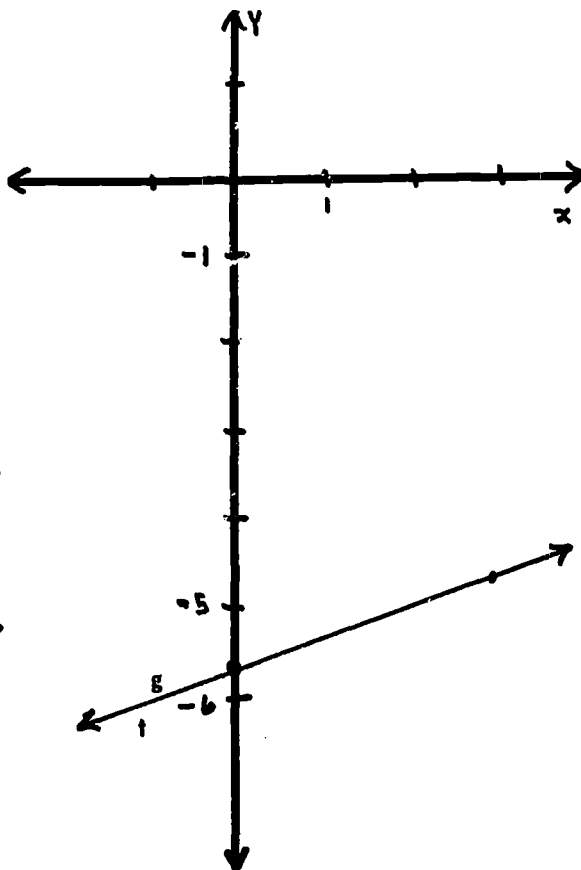

(e)  $x \xrightarrow{f} \frac{1}{2}x + 2$   
 $x \xrightarrow{g} 4x - 12$

$x = 4$

$(4, 4)$

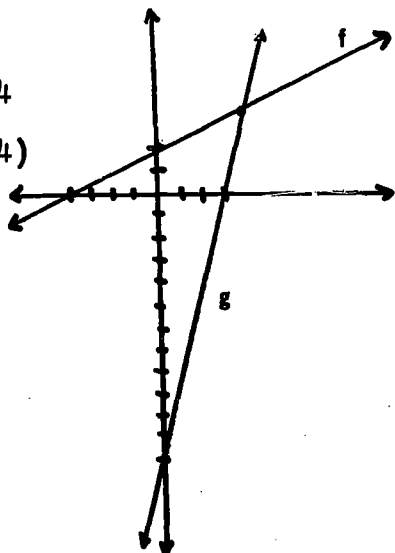

$$(f) \quad x \xrightarrow{f} -3x + 7$$

$$x \xrightarrow{g} -\frac{1}{3}x + 3$$

$$x = 1.5$$

$$(1.5, 2.5)$$

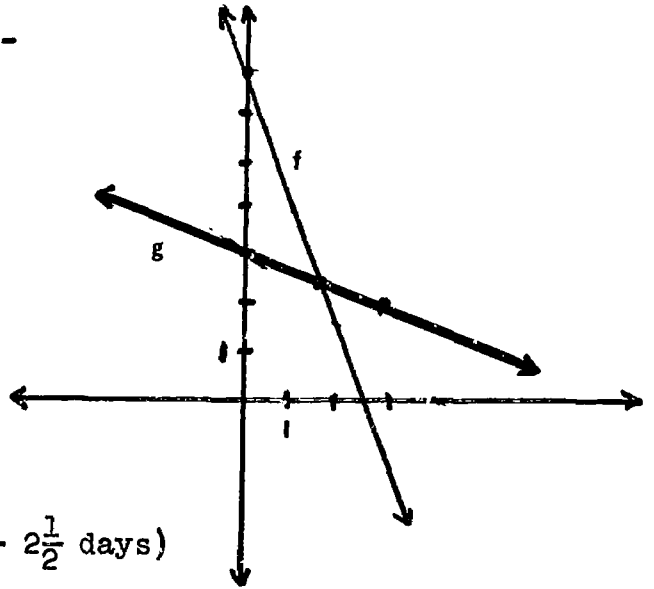

#### 4.9 Operations on Functions (2 - 2 $\frac{1}{2}$ days)

The treatment of the functions  $[f + C_a] = [f + a]$  and  $[C_a \cdot f] = [af]$  for  $a \in P$  is an extension of the work done with operations on functions in Course II, Chapter 7. These notions, together with  $[f + g]$  and  $[f \cdot g]$  will be utilized in Chapter 5 in developing polynomial functions and polynomials.

Given a function  $f$ , new functions  $f_1$  and  $f_2$  may be constructed by the rules

$$f_1(x) = f(x + a), \quad a \in R \setminus \{0\}$$

$$f_2(x) = f(ax), \quad a \in R \setminus \{0\}.$$

But defining them in this way obscures the fact that  $f_1$  is in fact a composite function, as is  $f_2$ . If  $g_1(x) = x + a$  and  $g_2(x) = ax$ , then  $f_1 = f \circ g_1$  and  $f_2 = f \circ g_2$ . The general case may be studied for  $g_3 = ax + b$ . Then  $f_3 = f \circ g_3$  is the function with rule  $f_3(x) = f(ax + b)$ . This particular composition is important in trigonometry where for example  $f(x) = \sin x$  so that  $f \circ g_3(x) = \sin(ax + b)$ . Note that in the examples  $g_1$  and  $g_2$  in effect respectively translate and dilate the  $x$  - axis before applying  $f$ .  $g_3$  is an affine transformation of the  $x$  - axis.

Care should be taken to point out the use of composition in

constructing the graphs as in Figure 4.24 and Figure 4.25.

Emphasis should be placed on doing all the work, if possible, on the graph itself, working from the graph of a simple function, or a given graph, to the graph of the function required. Encourage students to elaborate or simplify the graphic techniques. Try not to insist on a single approach.

Suggestion: It may be desirable for students to make master copies of graphs of such standard functions as  $q$  where  $q(x) = x^2$  and to trace the functions when using them in graphing others.

Exercises: 2. (e) is troublesome because of the scale factor involved. You may use  $k_1(x) = 2x$  instead if you like. Also, suggest appropriate intervals of the domain in troublesome exercises on which to graph the function. Symmetry may also be used here as an aid to graphing.

Exercises 1. (a) and (b) are good classroom exercises.

#### 4.10 Exercises

1. (a)  $f : y = |x|$                        $j : y = x$   
 $g : y = [x]$                                $c_1 : y = 1$   
 $h : y = x + 5$                              $q : y = x^2$   
 $k : y = 4x$
- (b) (i)  $y = |x| + [x]$                       (ii)  $y = |x| + x + 5$   
(iii)  $y = 5x + 5$                             (iv)  $y = |x| \cdot [x]$   
(v)  $y = [x + 5]$                             (vi)  $y = 4x|x|$   
(vii)  $y = x + 5$                             (viii)  $y = x^2 + x + 5$   
(ix)  $y = x^2 + 4x$                             (x)  $y = [4x]$   
(xi)  $y = x^2 + 4x + 1$                       (xii)  $y = x^2$

(xiii)  $y = x^2 + 4x + 1$

(xiv)  $y = 4x^2 + 20x$

(xv)  $y = [x^2]$

(c)

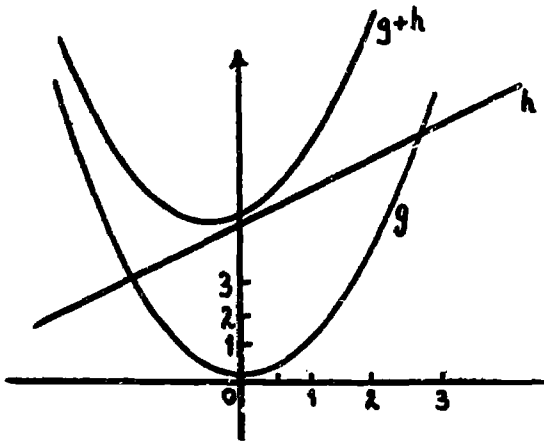

(e)

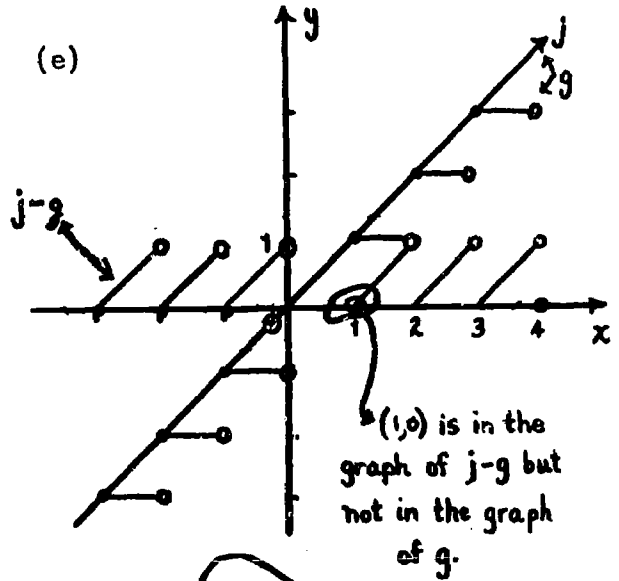

(d)

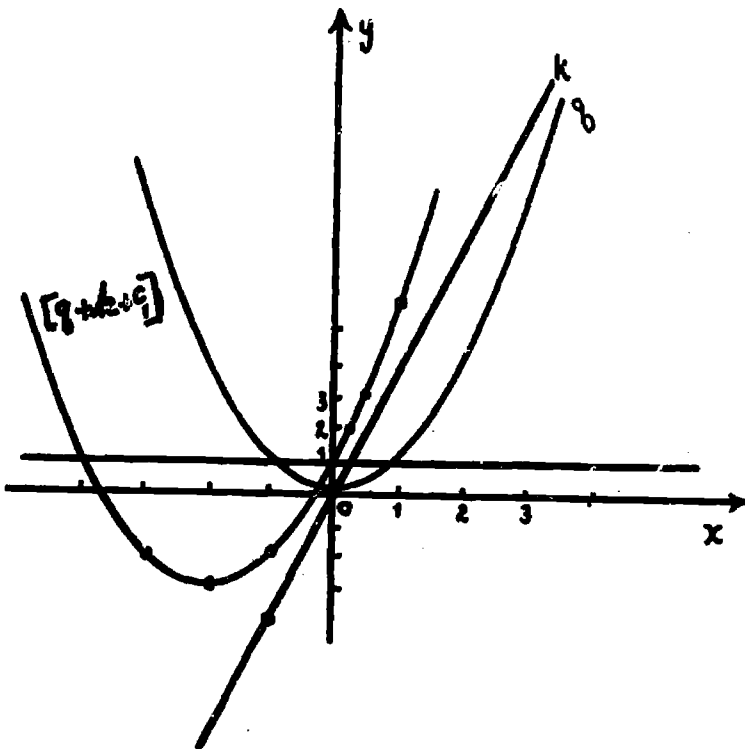

(f)

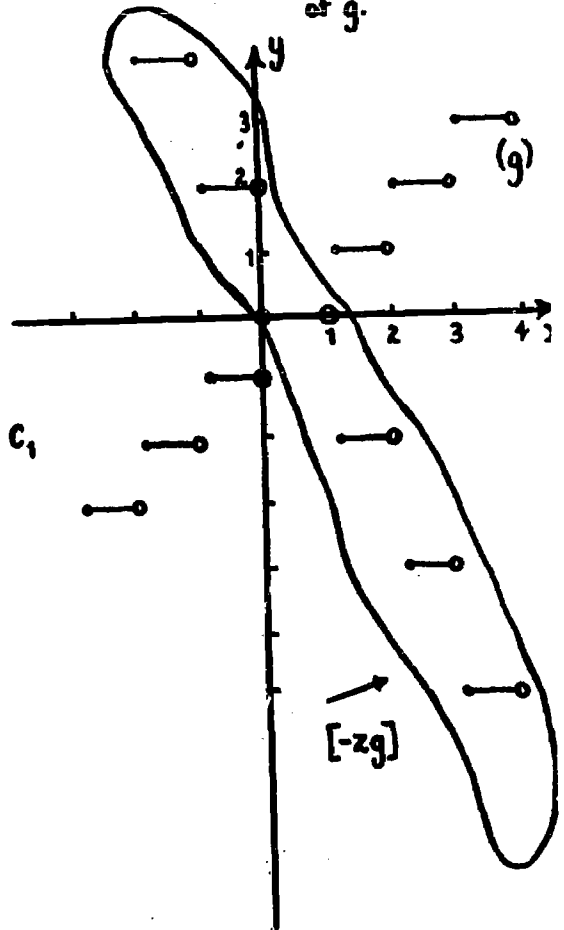

(g)

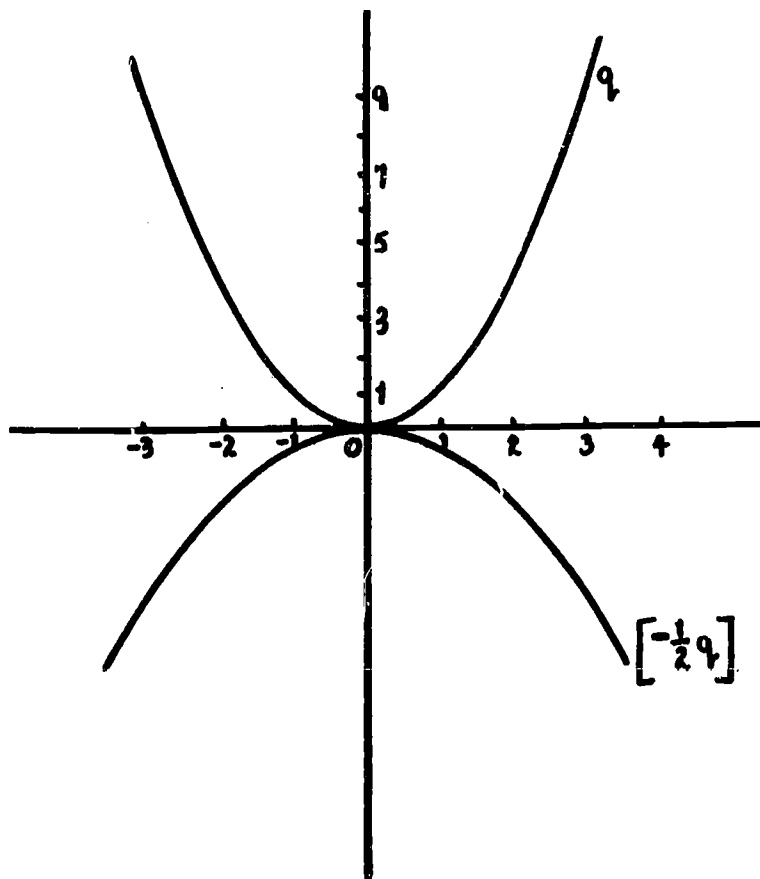

(h)

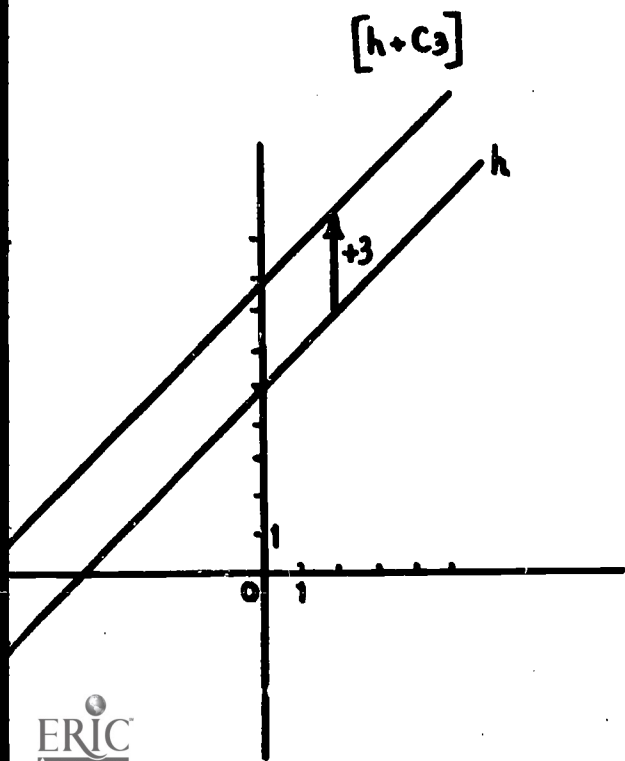

(i)

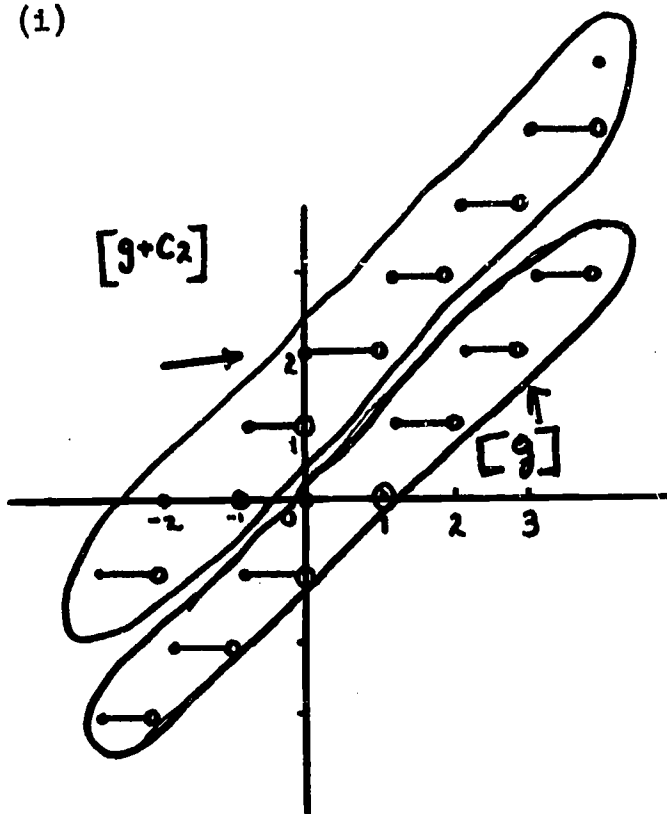

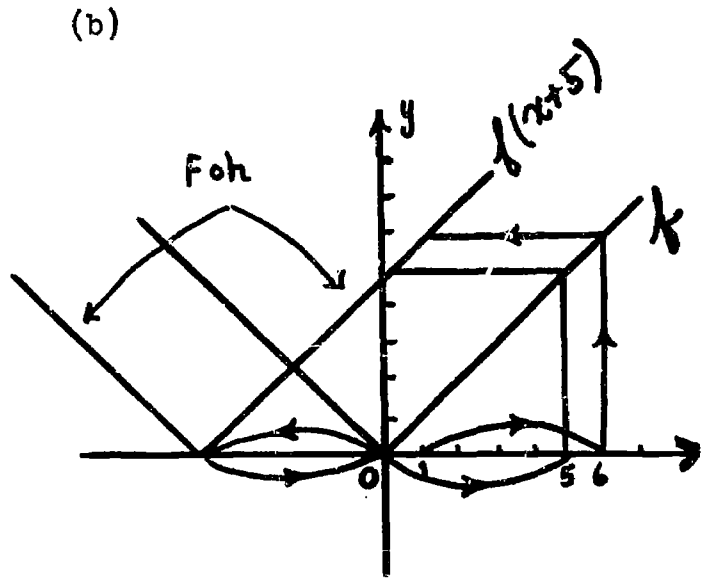
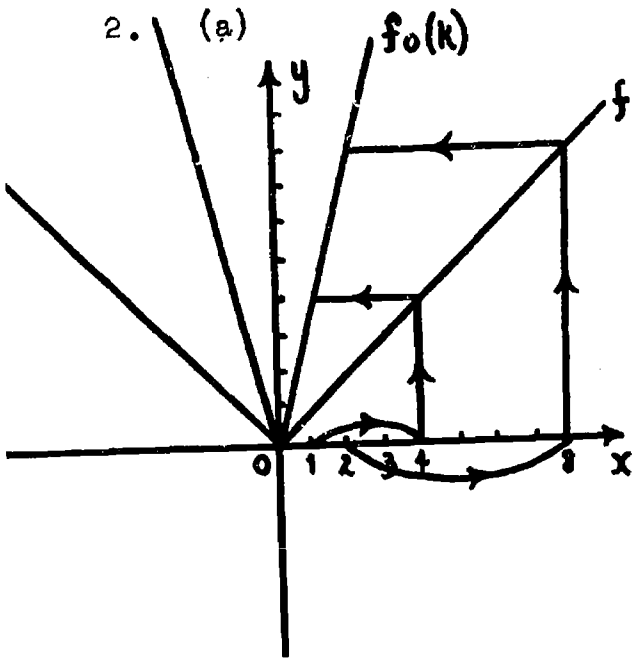

2. (c) - (f) are done in a similar fashion. The finished graphs are shown below.

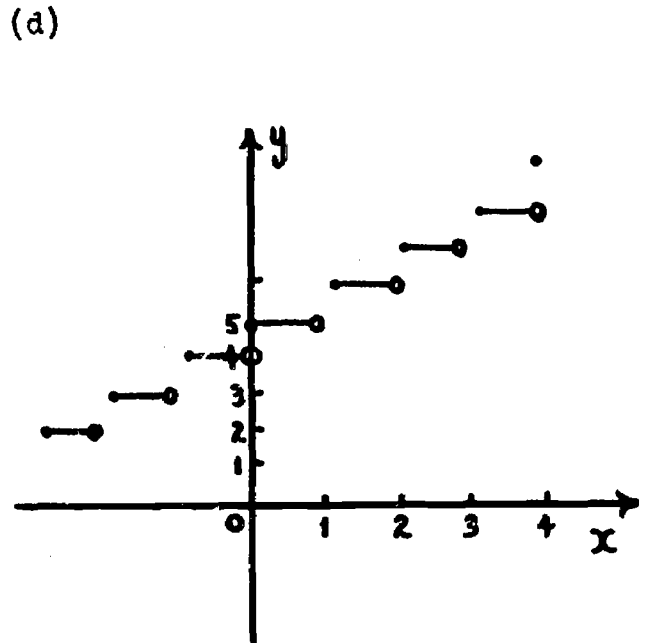
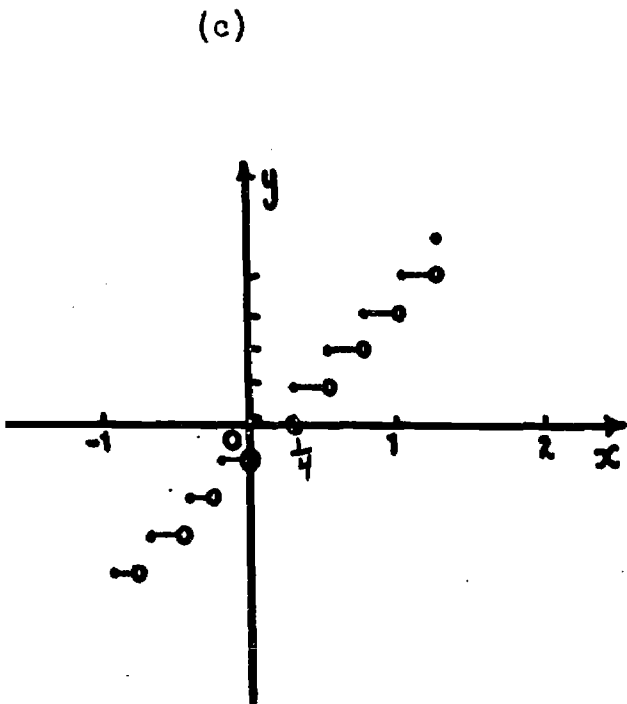



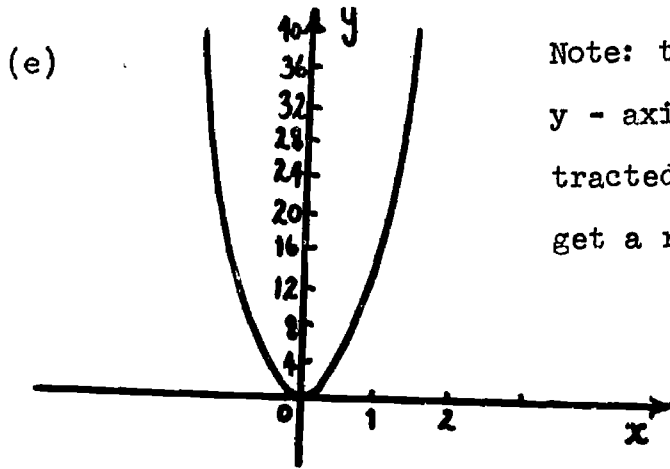

Note: the scale on the y - axis must be contracted drastically to get a reasonable picture.

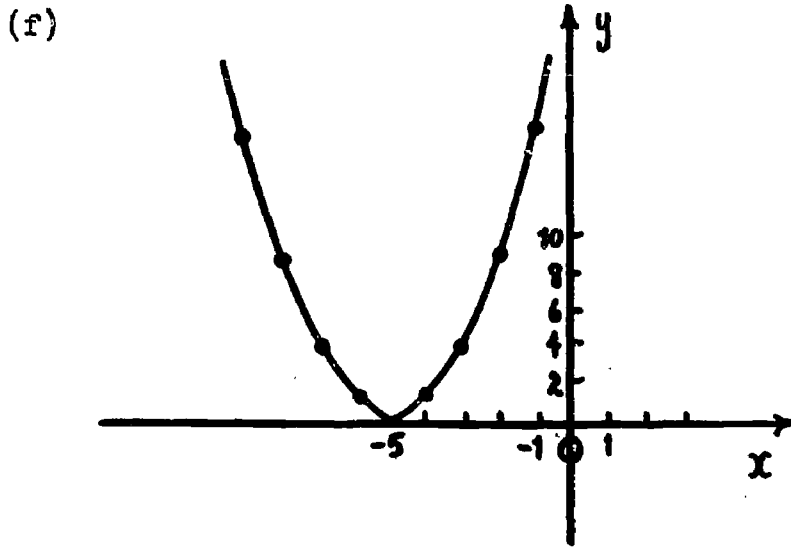

3. The completed graphs are shown.

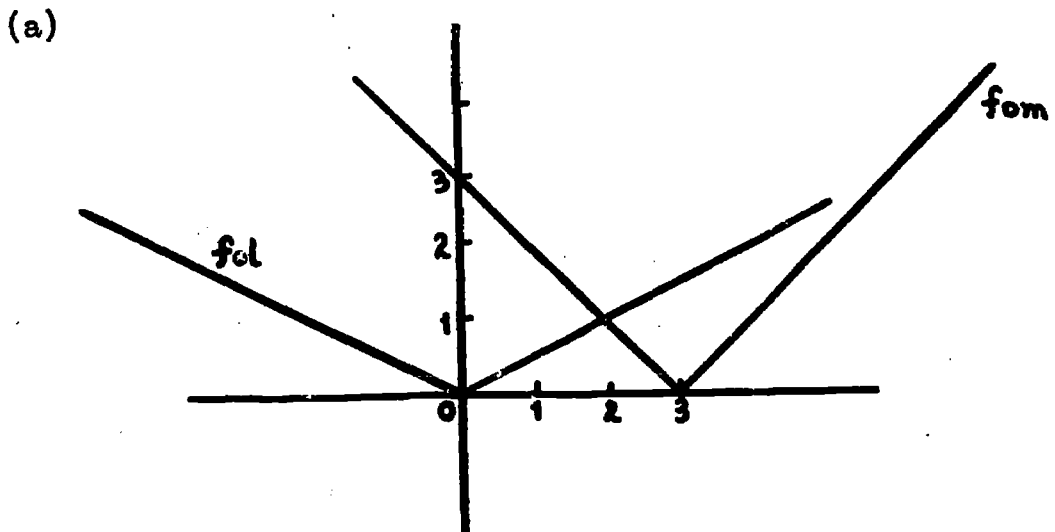

(b)

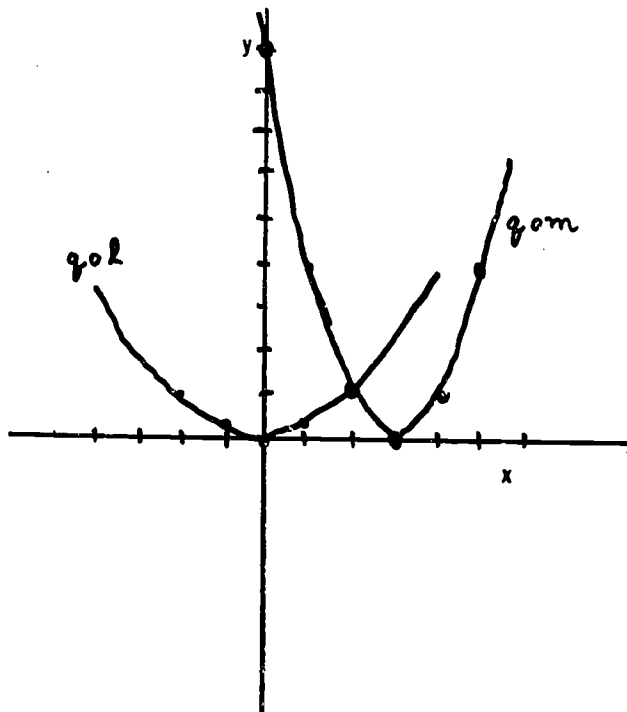

(c)  $l$  has a dilating effect and  $m$  a translating effect.  $k$  has a dilating effect in just the opposite way from  $l$ .  $l$  tends to enlarge while  $k$  shrinks. Both  $m$  and  $h$  translate the original graph.

4. (a) - (b)

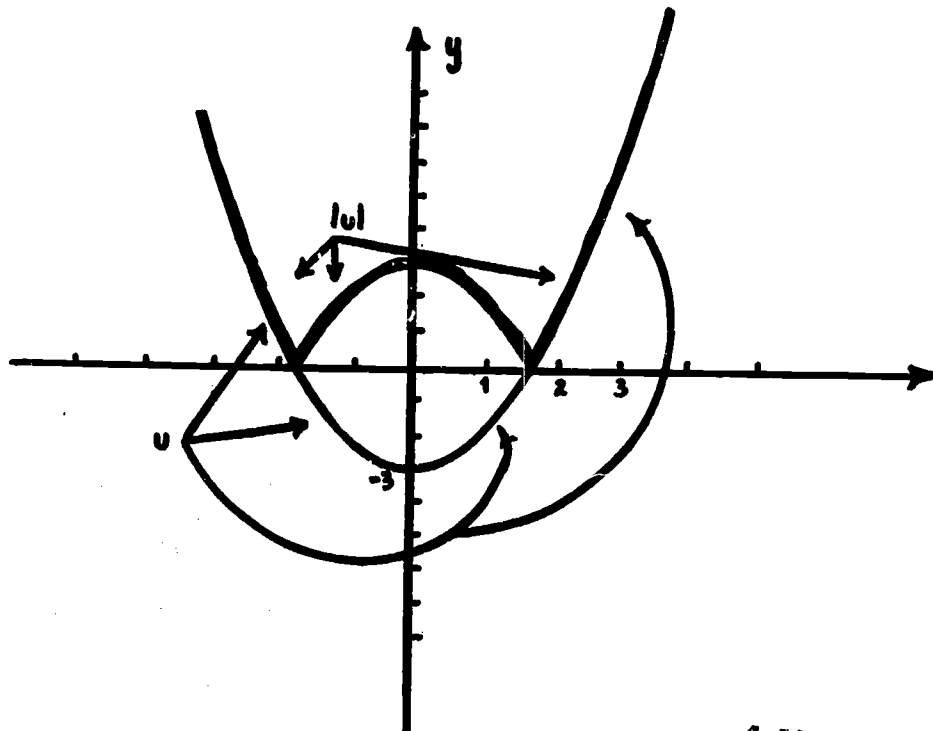

5.

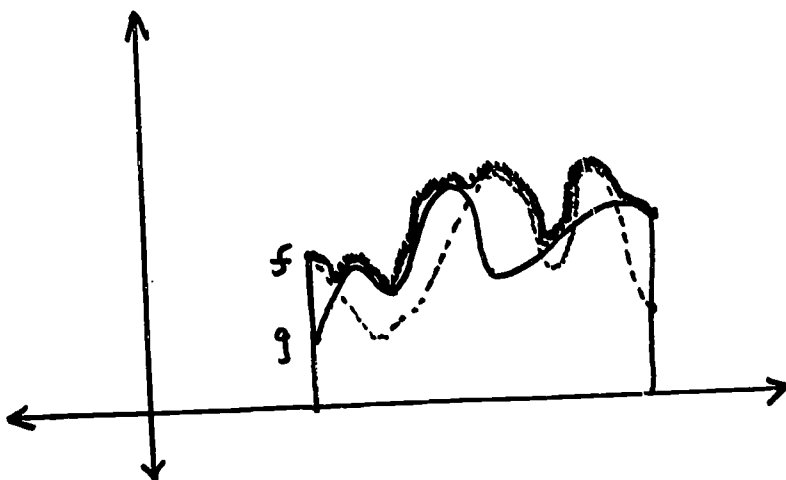

$\max(f, g)$  is the shaded part of the graph.

4.11 Bounded Functions and Asymptotes (2 -  $2\frac{1}{2}$  days)

Note that  $\frac{1}{f}$  is really  $j \circ f$ , where  $j$  is the function with rule  $x \xrightarrow{j} \frac{1}{x}$ . Thus, the study of  $\frac{1}{x}$  tells us how to expect  $\frac{1}{f}$  to behave for small values of  $|f(x)|$ , for large values of  $|f(x)|$  and for values of  $|f(x)|$  near 1. However, this approach is not used directly in the text since we wish to define  $\frac{1}{f}$  directly and illustrate by constructing  $1/j$ , where  $x \xrightarrow{j} x$ .

Note the assumption of continuity and that  $f(x)$  continues to increase as  $x$  increases for  $x > x_0$  and continues to decrease as  $x$  decreases for  $x < x_1$ .

Exercise 3 should be assigned, but it is not expected that students will be able to carry it through completely. Do it thoroughly but informally (graphically if possible) in class.

4.12 Exercises

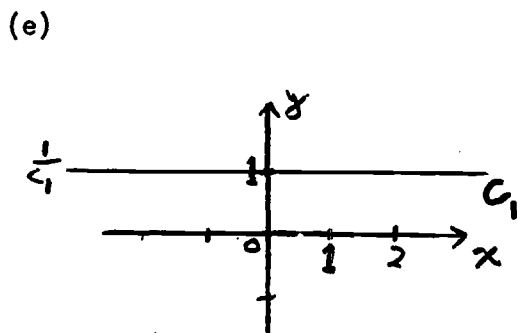
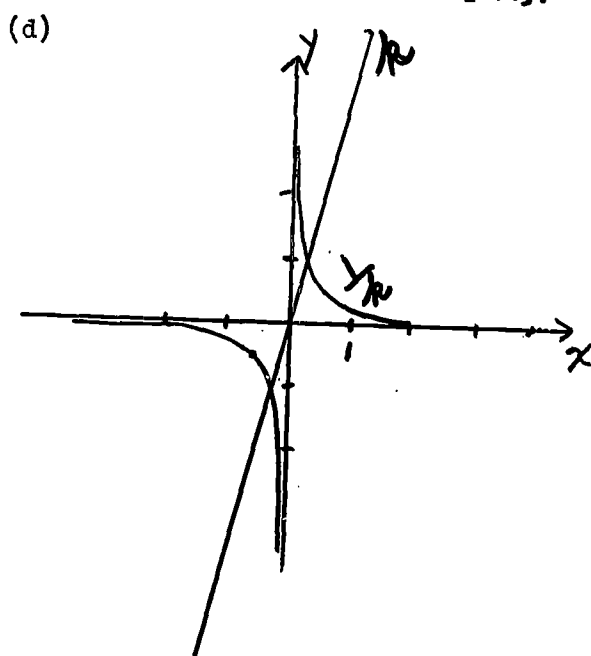
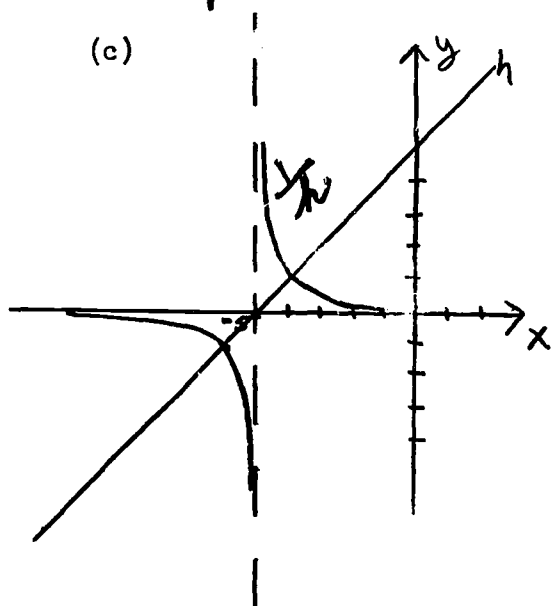
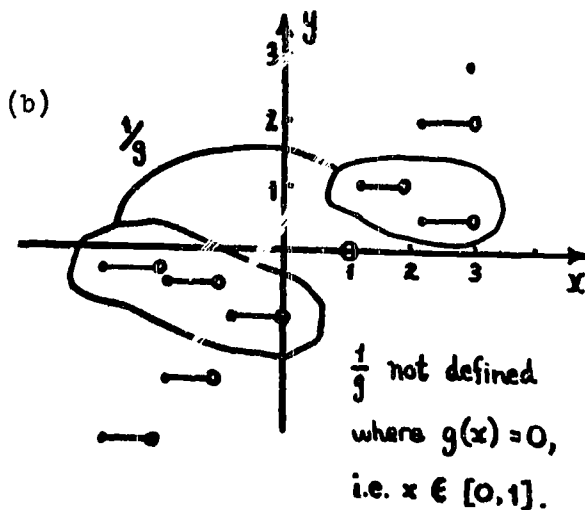
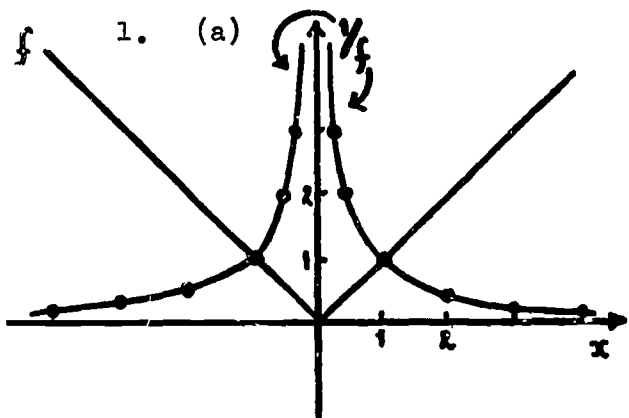

2. (a)  $\frac{1}{f} : y = 0$  ||  $c_1 : \text{none}$   
 $\frac{1}{g} : \text{none}$  ||  $c_3 : \text{none}$   
 $\frac{1}{h} : y = 0$  ||  $c_4 : \text{none}$   
 $\frac{1}{k} : y = 0$  ||  $q : y = 0$

(b)  $f : x = 0$  ||  $c_1 : \text{none}$   
 $g : \text{none}$  ||  $c_3 : \text{none}$   
 $h : x = -5$  ||  $c_4 : \text{none}$   
 $k : x = 0$  ||  $q : x = 0$

(c)  $\frac{1}{g}, \frac{1}{c_1}, \frac{1}{c_3}, \frac{1}{c_4}$  all have a local max and a local min at each point of their domain, technically. However, the student's intuitive answer will no doubt be no for all the reciprocal functions in (1) and this should be accepted as correct.

(d)  $f : \text{not bounded}$     $c_1 : \text{bounded}$       (e)  $\frac{1}{g}$  is bounded;  
 $g : \text{not bounded}$     $c_3 : \text{bounded}$       also, so are  
 $h : \text{not bounded}$     $c_4 : \text{bounded}$        $\frac{1}{c_1}, \frac{1}{c_3}, \frac{1}{c_4}$ .  
 $k : \text{not bounded}$     $q : \text{not bounded}$    (f) \_\_\_\_\_

3. (a) Yes. Since  $|f(x)| \leq k_1$  for all  $x \in [0, 1]$ ,  $k_1 > 0$ , and  $|g(x)| \leq k_2$  for all  $x \in [0, 1]$ ,  $k_2 > 0$ ,  
 $|f(x)| + |g(x)| \leq k_1 + k_2$  for all  $x \in [0, 1]$ .  
 But  $|f(x) + g(x)| \leq |f(x)| + |g(x)|$  by the triangle inequality.  $\therefore |[f + g](x)| \leq k_1 + k_2 = k$  for all  $x$  in  $[0, 1]$ .
- (b) Yes. The identity is 0.  $f + g$  is restricted to  $[0, 1]$ , which is clearly a bounded function.  $-f \in B$  since for all  $x \in [0, 1]$ ,  $|-f(x)| = |f(x)| \leq k$ .
- (c) Yes since  $|\alpha f(x)| = |\alpha| |f(x)| \leq |\alpha| k$  where  $|f(x)| \leq k$ .

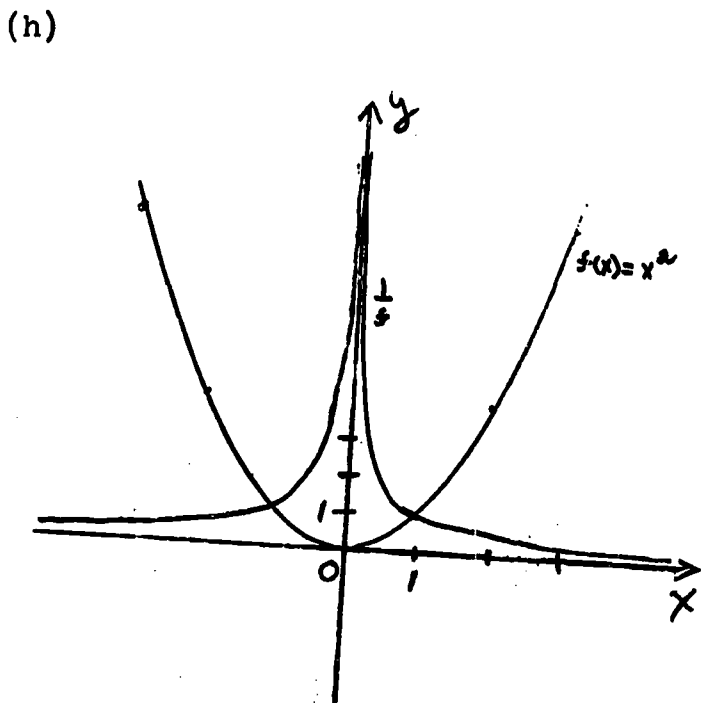
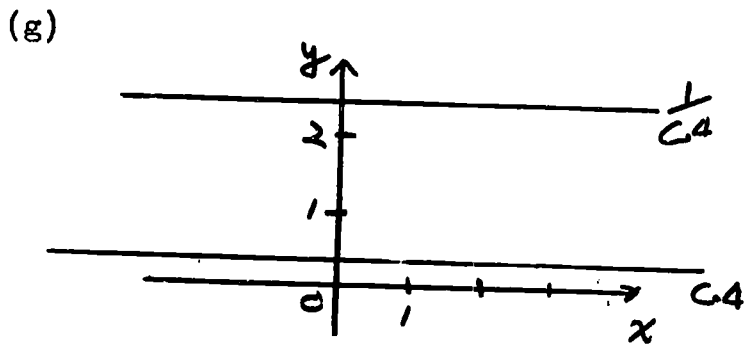
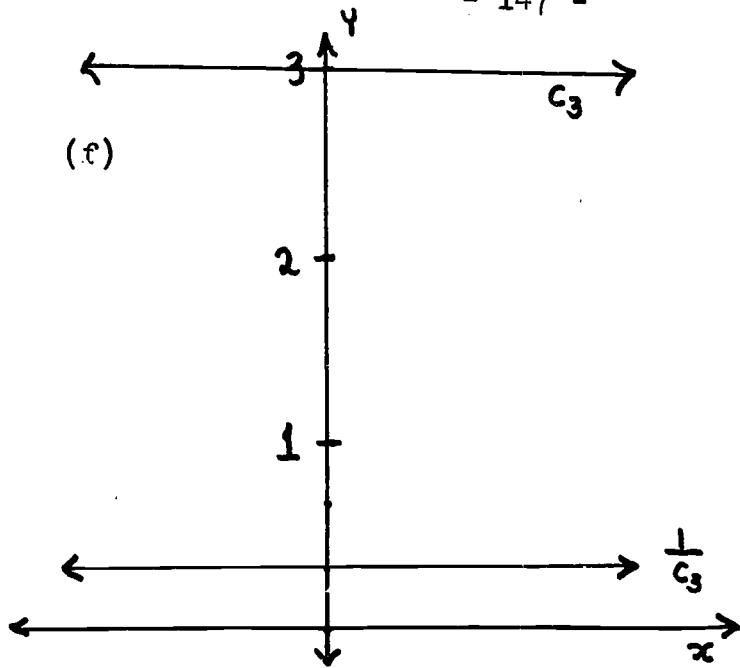

4.14 Exercises

1.

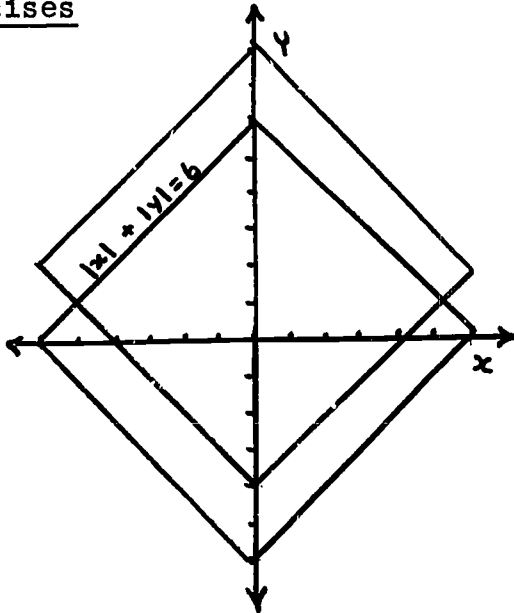

2. Each of the following are isolated examples. There are, however, many such examples possible.

(a)

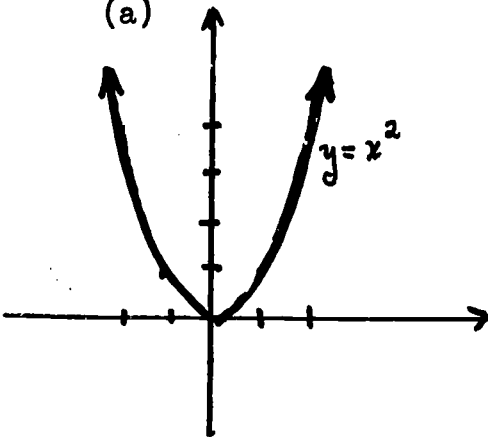

(b)

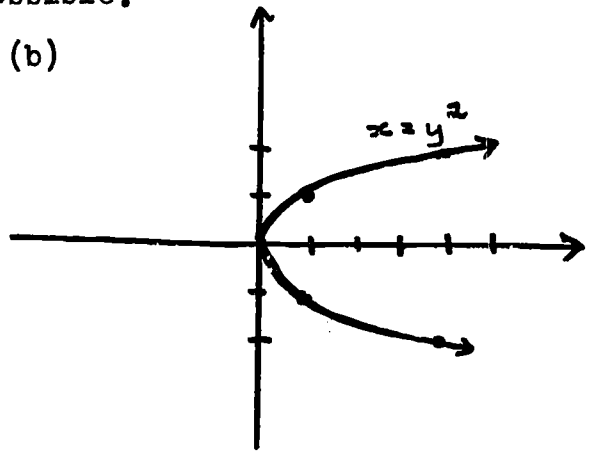

(c)

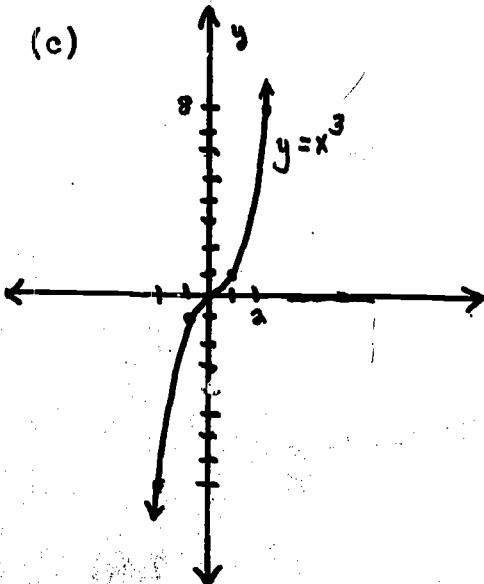

(d)

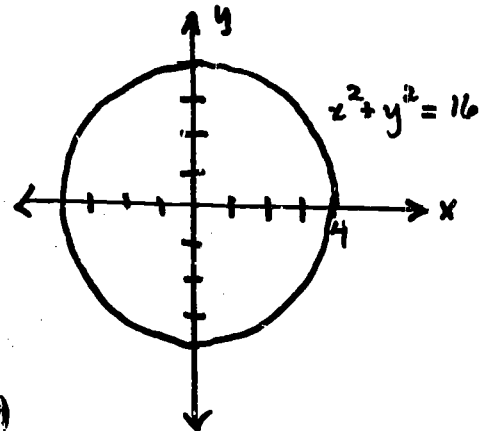

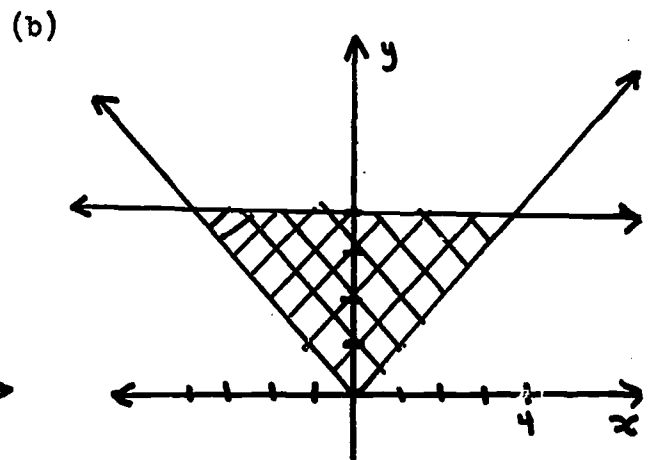
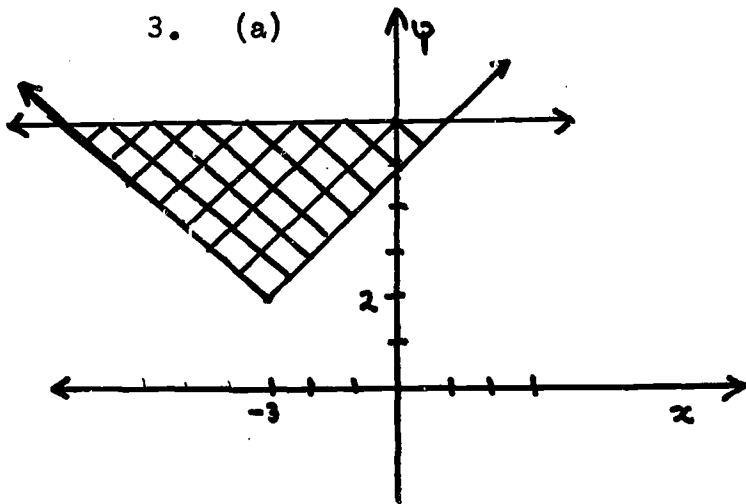
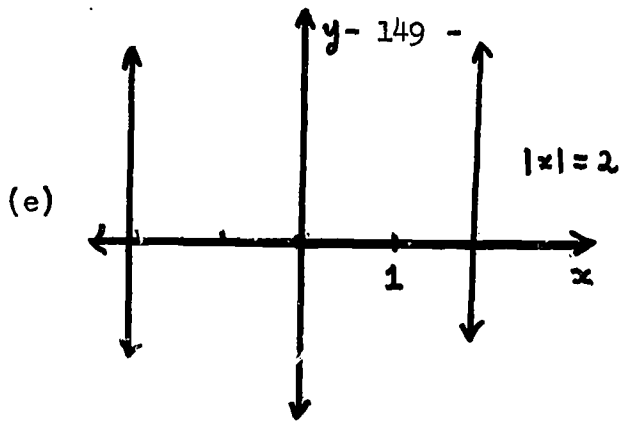

(c)  $y \geq |x|$  and  $y \leq 4$

4. No

5. (a)

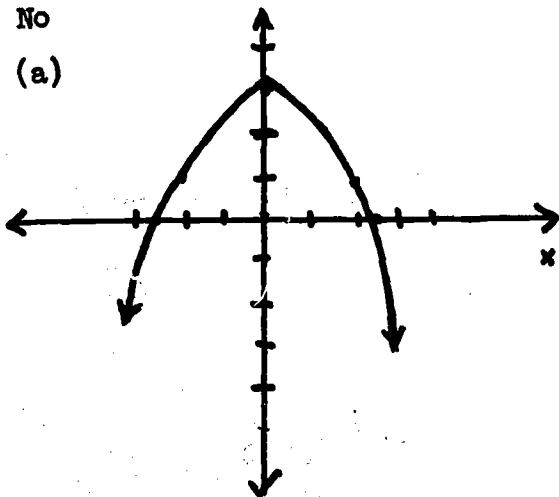



(b) (i)  $\{\sqrt{6}, -\sqrt{6}\}$ , (ii)  $\{-2, 2\}$ , (iii)  $\{-\sqrt{10}, \sqrt{10}\}$

(c)

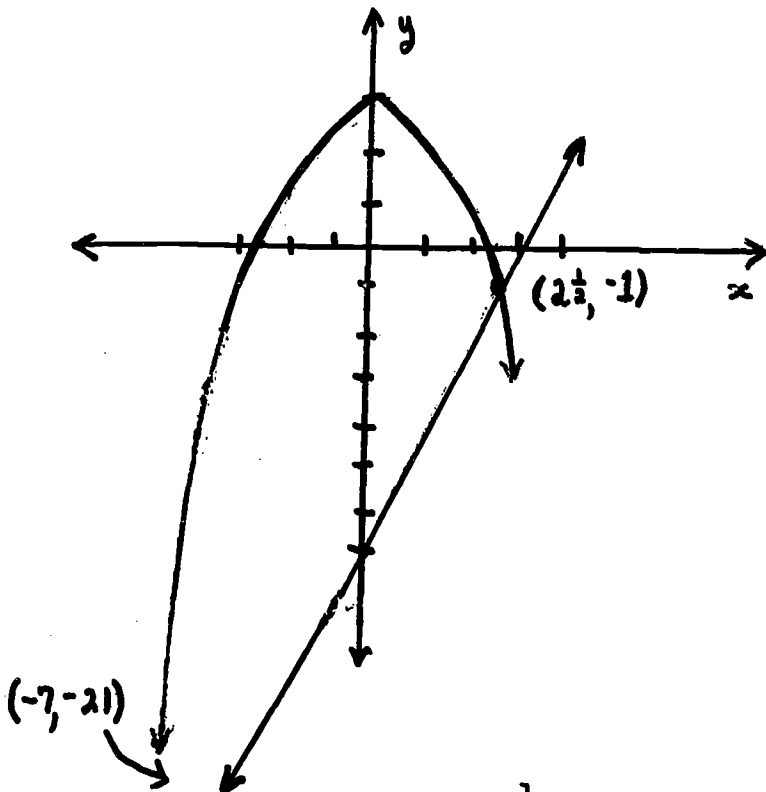

These answers are approximate.

6. (a)  $x^f \rightarrow \frac{1}{2}x^2, x \in \mathbb{R}$

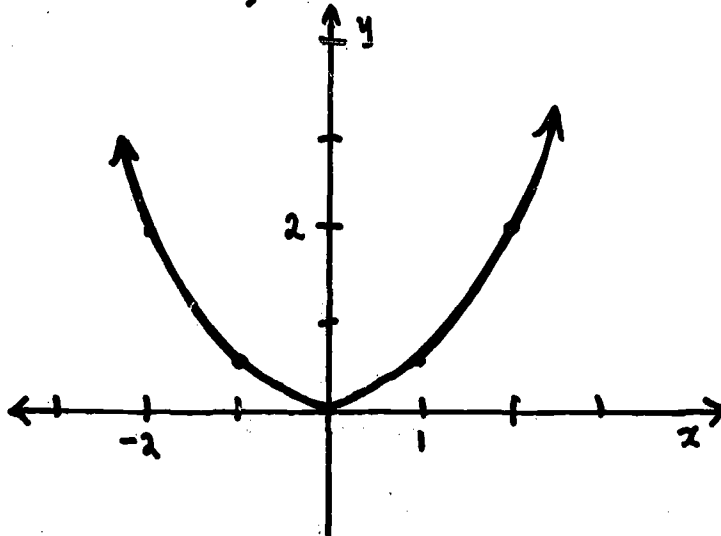

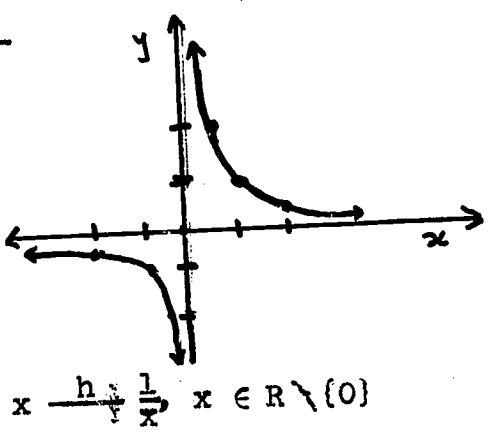
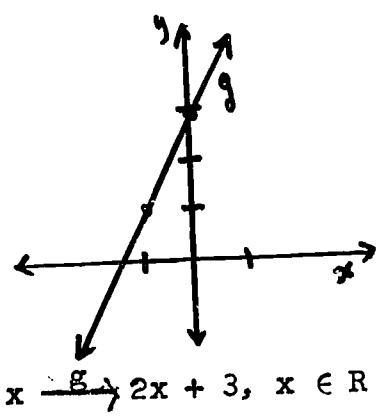

(b)  $x \xrightarrow{f} \frac{1}{8}x^2$

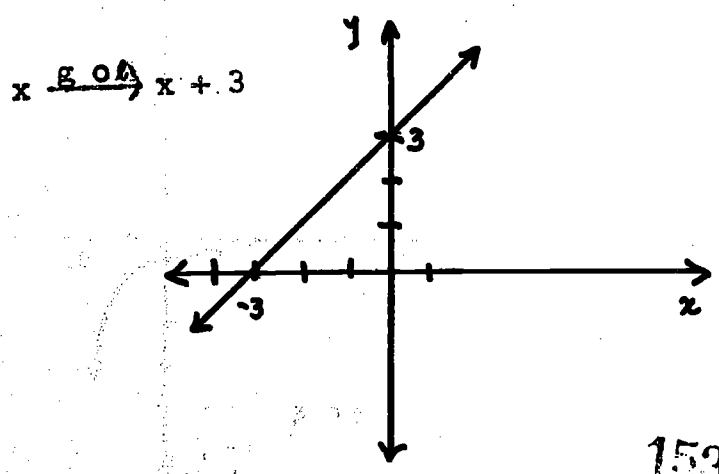
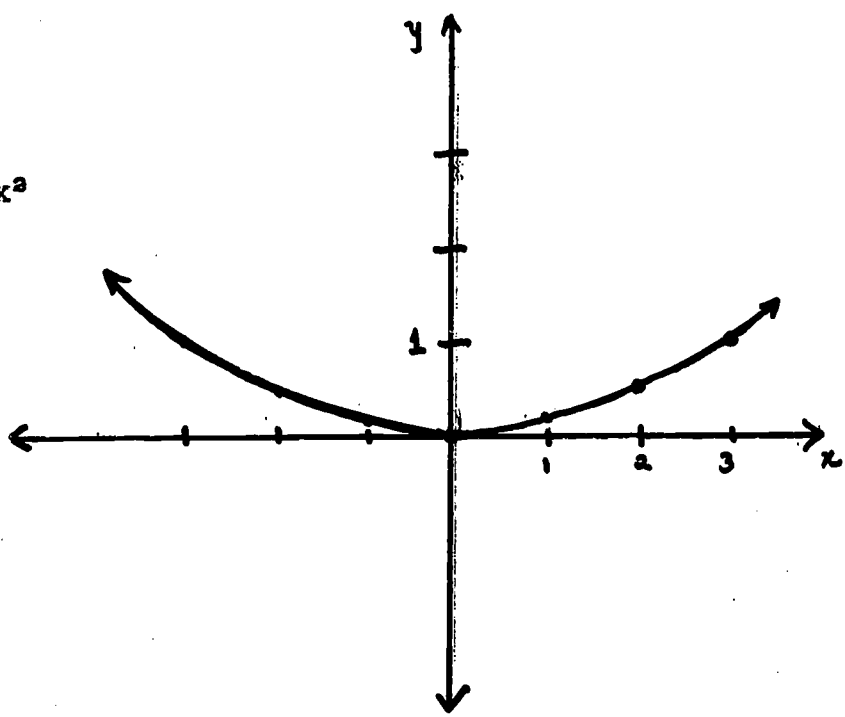

$$x \xrightarrow{\text{hol}} \frac{2}{x}$$

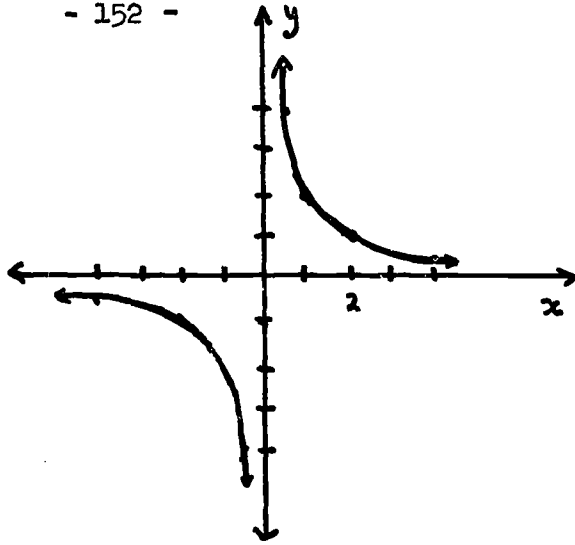

(c)  $x \xrightarrow{\text{fom}} \frac{x^2}{2} - 2x + 2$

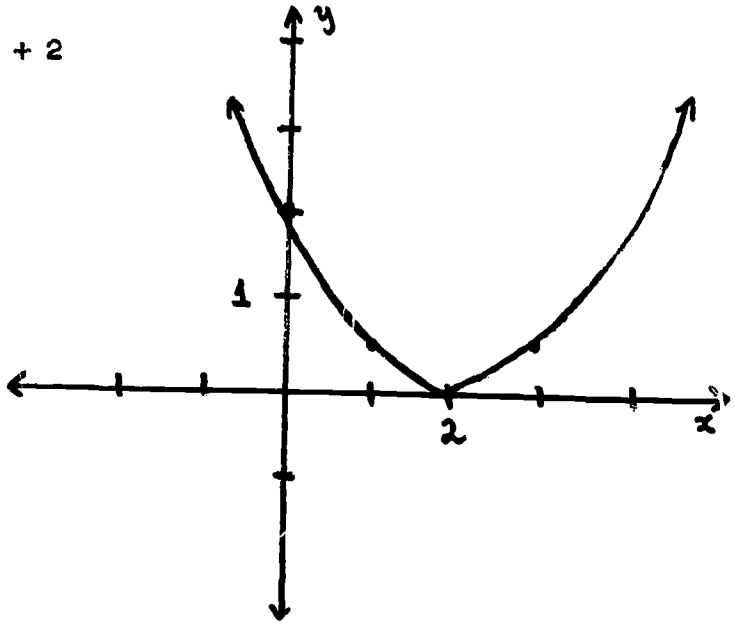

$$x \xrightarrow{\text{gom}} 2x - 1$$

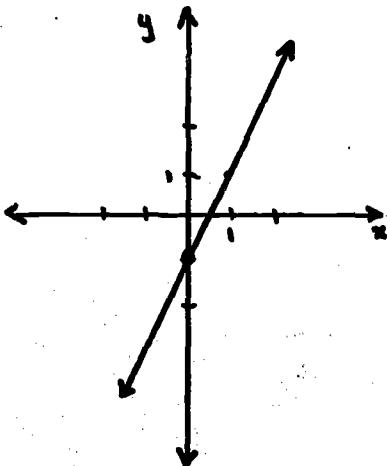

$$x \xrightarrow{\text{hom}} \frac{1}{x-2}$$

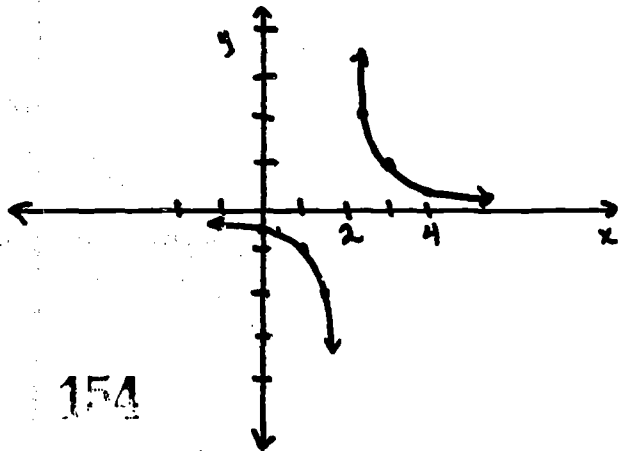

7. (a)  $\frac{1}{f}$  is the dotted graph.

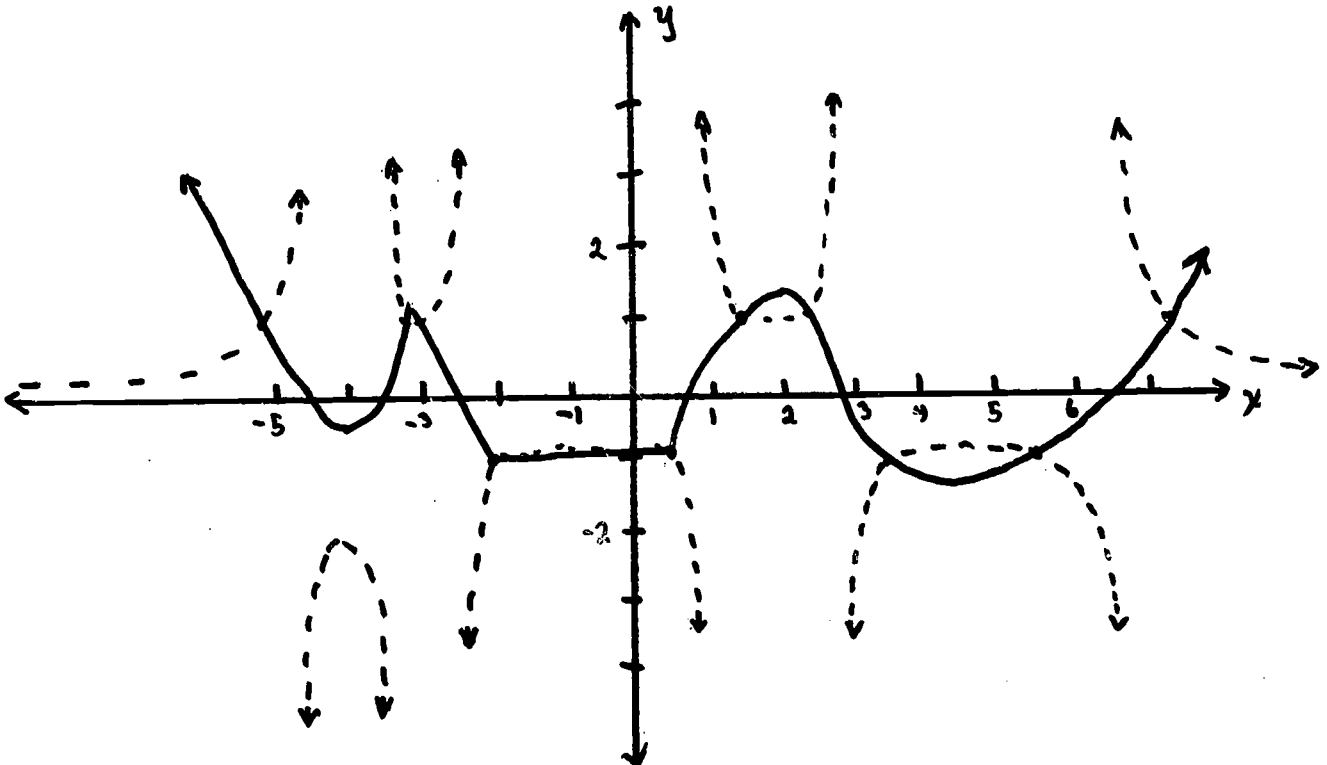

(b) Local Max. $(-4, -\frac{1}{4})$ ; $(2, \frac{1}{4})$	} for $\frac{1}{f}$
Local Min. $(-3, -\frac{1}{3})$ ; $(4, -\frac{1}{4})$	
Local Max. $(-3, 1)$ ; $(2, 1)$	} for $f$
Local Min. $(-4, -2)$ ; $(4, -2)$	

(c)  $x = -4\frac{3}{4}, x = -3\frac{1}{2}, x = -2\frac{1}{2}, x = \frac{3}{4}, x = 2\frac{3}{4}, x = 6\frac{1}{2}$

$y = 0$

(d)  $-4 \leq x \leq 1$  for  $f$

$-2 \leq x \leq 0$  for  $\frac{1}{f}$

Chapter 4 Sample Test on Graphs and Functions

I. Tell whether each of the following is a function equation for the domain specified. If it is not, explain why not.

(a)  $y = x^2 + 4, x \in \mathbb{R}.$

(b)  $y = x + 4, x \in \mathbb{R}.$

(c)  $y = \frac{1}{x+4}, x \in \mathbb{R}.$

(d)  $|y| = |x| + 4, x \in \mathbb{R}$

(e)  $x^2 + y^2 = 4, x \in [-2, 2]$

II. Discuss the symmetry of the graphs of each of the following conditions.

(a)  $|x| + |y| = 3$

(b)  $y = 3x^2$

(c)  $y = 3x - 1$

(d)  $y = |x + 3|$

(e)  $y = x^3$

III. Graph the compound condition :  $y \geq 0, y \leq -x + 5,$   
 $x \leq 0,$  and  $y \leq \frac{4}{3}x + 8.$

IV. Given the following functions of  $\mathbb{R}$  to  $\mathbb{R}$  with rules:

$x \xrightarrow{f} x + 3$        $x \xrightarrow{h} [x]$        $x \xrightarrow{k} x^2$

(a) Draw the graph of  $k$ . Then use it to construct the graph of  $-3k$ . Label each graph carefully. Write the function equation for  $-3k$ .

(b) Draw the graph of  $h$ . Then use it to construct the graph of  $h \circ f$ . Label each graph carefully.

V. Study the 3 graphs {a, b, c} at the right and then answer these questions:

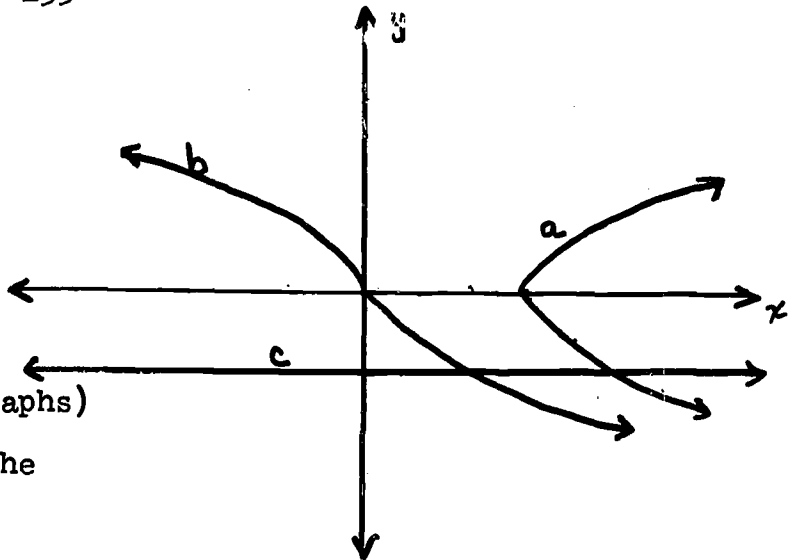

- (a) Which graph (or graphs) are symmetric in the origin?
- (b) Which graph (or graphs) are symmetric in the  $y$  - axis?
- (c) Which graph (or graphs) are functions of  $x$ ?
- (d) Which graph (or graphs) are bounded?

VI. At the right is a graph of the function  $f$ .

(a) On the same axes, sketch the graph of  $\frac{1}{f}$ .

(b) Write the equations ( $x = a$ ;  $y = b$ ) for asymptotes of  $\frac{1}{f}$ .

(c) Give an interval in which  $\frac{1}{f}$  is bounded:

(d) If a local maximum of  $\frac{1}{f}$  exists, give its coordinates. (If none exists, write "none").

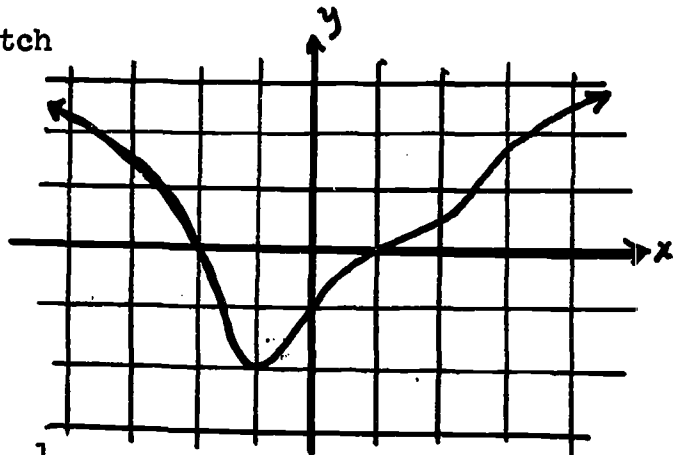

Answers to Test Questions

I. (a) Yes

(b) Yes

(c) Yes

(d) No,  $1 \rightarrow 5$ ;  $1 \rightarrow -5$

(e) No,  $0 \rightarrow 2$ ;  $0 \rightarrow -2$

II. (a) Symmetric to x - axis, y - axis and origin.

(b) Symmetric to y - axis.

(c) No symmetry

(d) No symmetry

(e) Symmetric to origin

III.

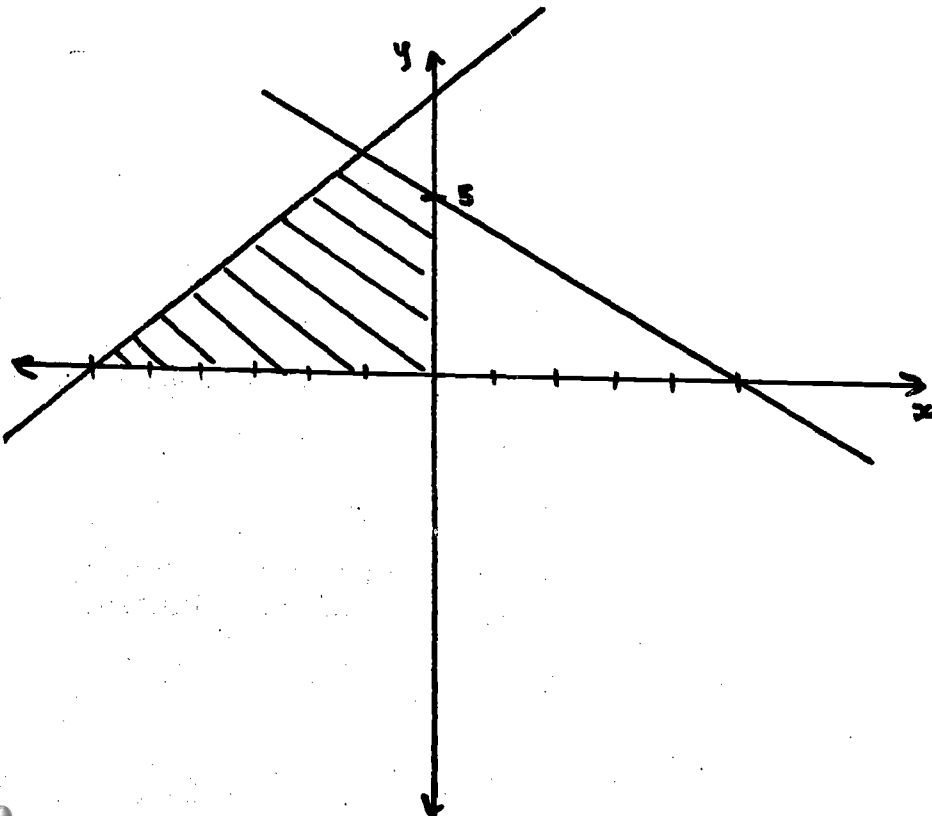

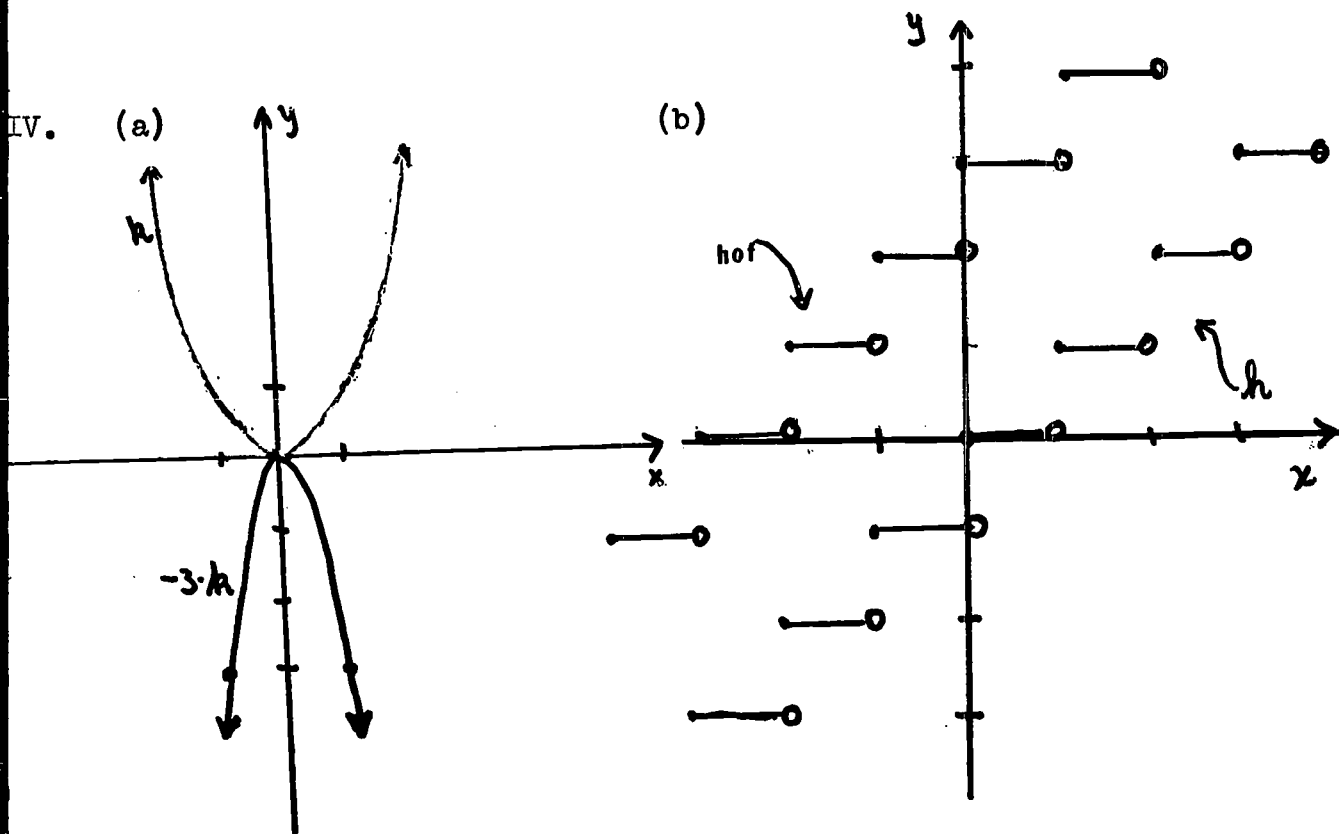

- V. (a) b  
 (b) c  
 (c) b, c  
 (d) c

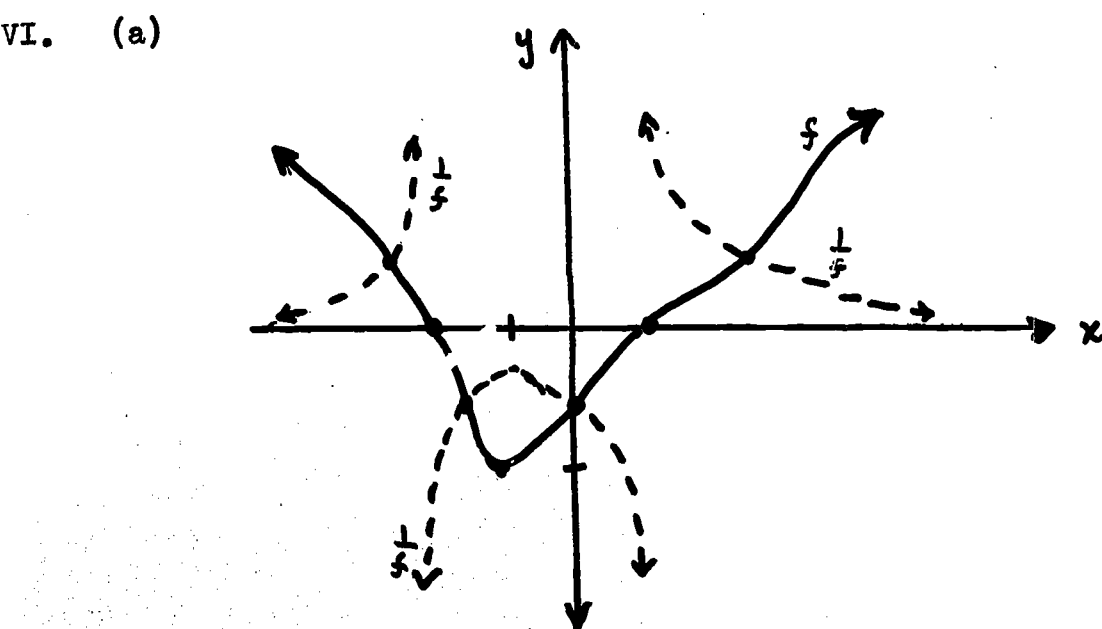



(b)  $x = -2; x = 1$

$y = 0$

(c)  $2 \leq x \leq 4$

(d)  $(-1, -\frac{1}{2})$

Chapter 5  
COMBINATORICS

Time Estimate: 21 days

General Introduction

This chapter formalizes some of the principles involved in combinatorics with its application to the binomial expansion and in preparation for the chapter on Probability which follows. Section 5.9 postulates the Principle of Mathematical Induction.

The teacher should restrict the time to the concepts and skills introduced in the chapter. There are a few problems in the sections involving probability. These should be done with the use of previous knowledge of the students or by informal methods. Students could be asked to list the successful events and all possible outcomes to derive the probability of an event. The emphasis must be on combinatorial counting with application to simple problems.

The development of the concepts of permutation and combination is closely tied to previous work with 1:1 mappings and subsets. A permutation is defined as a 1:1 mapping of a set A into a set B. Examples in 5.2 develop the notion of permutation as a 1:1 mapping between two sets.  $(n)_r$  denotes the number of permutations of  $n$  objects taken  $r$  at a time (number of

1:1 mappings from a set A consisting of  $r$  elements into a set B with  $n$  elements).

Section 5.4 reviews the meaning of the power set of a given set, and 5.5 employs the concept of subset in developing the meaning of the term combination.  $\binom{n}{r}$  denotes the number of combinations of  $n$  objects taken  $r$  at a time, or in subset terminology, it refers to the number of  $r$ -element subsets of a given set of  $n$  elements.

In section 5.7 the concept of subset is used in determining the coefficients in a binomial expansion. Problems dealing with the binomial theorem (5.8) and mathematical induction (5.10) provide students with practice in algebraic manipulation.

Experiences of teachers have shown the need for additional problems on applications of combinations and permutations. Some additional problems are provided in this commentary (see end of answer keys to sections 5.3 and 5.6).

In the next chapter, Probability (Section 6.6) students will need to apply their knowledge about permutations and combinations to some probability problems. (See Teachers Commentary, Chapter 6, p. 212, 226-227.)

## 5.1 Introduction

The purpose of the introduction is to give the student a little insight into the idea that combinatorics has become a branch of mathematics in its own right. Much research is being done; there are many unsolved problems for people who are interested to work on; and there are many applications of

combinatorics to other branches of mathematics.

5.2 The Counting Principle and Permutations (Time: 4 days  
or 5.2--Supplementary problems)

Several examples are given at the outset to develop the idea of a counting principle on an intuitive level. In each case the examples involve a set of tasks, each of which may be performed in any of a number of ways. The product of the numbers of ways in which the tasks may be performed individually is the number of ways that the set of tasks may be performed one after the other. The examples are self-explanatory and need no additional background. They should be discussed in detail with the class.

Wherever mappings are used to develop an idea, for example in the case of the number of permutations of  $n$  elements taken  $r$  at a time with  $r$  less than or equal to  $n$ , it is important that the students find each of the mappings involved and represent them with arrow diagrams. This is simply a "brute force" technique at first but yields a real payoff later in understanding.

A more general counting principle, CP', is presented after the intuitive one. It uses the set operation Cartesian product where the product of the numbers of elements in the two sets individually is the number of elements in the Cartesian product. (It is a coincidence that "counting principle" and "Cartesian product" have the same initials, C.P.)

It should be emphasized to the students that even though the sets involved are sometimes related to one another, it is not really necessary that they be related. The counting principle in any of its forms may be extended to more than two sets. (See Theorem 1, CP).

It may be that the diagrams illustrating all possible mappings in one picture may be a little confusing. In this case it might be worthwhile to have students represent each mapping individually on the board.

The counting principle is used to derive the formula for computing numbers of permutations. The symbol " $(n)_r$ " is becoming widely accepted in the textbooks at all levels.

### 5.3 Exercises

1. This exercise may be done two ways. Students should be told which way to interpret the problem or asked to do the problem with both interpretations. Answers with no letter used more than once.

(a) 7            (b) 42            (c) 210            (d) 840  
(e) 2520        (f) 5040        (g) 5040

Answers with letters repeating:

(a) 7            (b) 49            (c) 243            (d) 1701  
(e) 11,907        (f) 83,349        (g) 583,443

2. The students should see that the questions in Exercise 1 with no letters repeating and Exercise 2 are essentially the same. They represent different applications of  $(7)_r$ .

(a) 7    (b) 42    (c) 210    (d) 840    (e) 2520    (f) 5040    (g) 5040

3. Same as Exercise 2.

4.  $8 \cdot 7 \cdot 6 \cdot 5 \cdot 4 = 6720$

5.  $5! = 5 \cdot 4 \cdot 3 \cdot 2 \cdot 1 = 120$

6.  $5 \cdot 4 \cdot 3 = 60$

Exercises 7, 8 and 11 are not 1-1 mappings from one set to another. These permit all mappings from set A to B. If A has  $a$  elements and B has  $b$  elements and  $a \leq b$ , then the number of possible mappings (not necessarily 1-1) is  $b^a$ .

7. (a)  $26 \cdot 26 \cdot 10 \cdot 10 \cdot 10 = 676000$

(b)  $24 \cdot 24 \cdot 10 \cdot 10 \cdot 10 = 576000$

8. (a)  $10^{10}$  (b)  $9 \cdot 10^9$

(c)  $9 \cdot 10 \cdot 10 \cdot 9 \cdot 10^6$  or  $9^2 \cdot 10^8$

9.  $10 \cdot 4 = 40$

10.  $5 \cdot 4 = 20$

11.  $6^2$  or 36

12. (a)  $5 \cdot 4 \cdot 3 \cdot 2 = 120$  (b)  $8 \cdot 7 \cdot 6 = 336$

(c)  $8 \cdot 7 \cdot 6 \cdot 5 \cdot 4 = 6720$

(d)  $20 \cdot 19 = 380$  (e) 15,120

13. (a)  $8 \cdot 7 \cdot 6 = 336$

(b)  $8 \cdot 7 \cdot 6 \cdot 5 \cdot 4 \cdot 3 \cdot 2 \cdot 1 = 40,320$

(c)  $5 \cdot 4 \cdot 3 \cdot 2 \cdot 1 = 120$

(d) 336

14. (a)  $6 \cdot 5 \cdot 4 \cdot 3 = 360$

(b)  $6 \cdot 5 \cdot 4 \cdot 3 \cdot 2 \cdot 1 = 720$

(c)  $2 \cdot 1 = 2$

(d) 360

15. (a)  $10 \cdot 9 \cdot 8 = 720$   
(b)  $10 \cdot 9 \cdot 8 \cdot 7 \cdot 6 \cdot 5 \cdot 4 \cdot 3 \cdot 2 \cdot 1 = 3,628,800$   
(c)  $7 \cdot 6 \cdot 5 \cdot 4 \cdot 3 \cdot 2 \cdot 1 = 5040$   
(d) 720
16. Since  $(n - r)!$  gives the product of all counting numbers from 1 to  $(n - r)$ , then multiplying this by the product of the counting numbers from  $(n - r + 1)$  to  $n$  will give  $n!$  by definition of  $n!$ . Note that  $(n - r + 1)$  is the successor of  $(n - r)$ .

17. On the basis of the result for Exercise 16,  $n! = (n)_r \cdot (n - r)!$ . It then follows by dividing both sides of the above equation by  $(n - r)!$  that:

$$(n)_r = \frac{n!}{(n - r)!}$$

18. (a)  $(11)_3 = \frac{11!}{(11 - 3)!} = 11 \cdot 10 \cdot 9 = 990$   
(b)  $(7)_5 = \frac{7!}{(7 - 5)!} = 7 \cdot 6 \cdot 5 \cdot 4 \cdot 3 = 2520$   
(c)  $(15)_3 = \frac{15!}{(15 - 3)!} = 15 \cdot 14 \cdot 13 = 2730$   
(d)  $(100)_2 = \frac{100!}{(100 - 2)!} = 100 \cdot 99 = 9900$

19. Answers may vary. Students may give straightforward answers such as "number of permutations of 8 elements taken 2 at a time." Or they may do it in terms of mappings, in terms of applications.

21. (a)  $8! = 40,320$  (b)  $12! = 479,001,600$   
(c)  $6 + 2 + 1 + 1 = 10$  (d) 288  
(e) 33

22. 2-digit, 4; 3-digit, 8; 4-digit, 16. 166

In order to give the students additional practice in the kinds of word problems involving permutations, the following set of problems are included to be used at the discretion of the teacher.

1. In how many ways can 4 seats in a row be filled by selecting from 6 people?
2. In how many ways can 4 people seat themselves in 6 seats?
3. Two dice are tossed. In how many ways can they fall?
4. How many distinct license plates for cars can be made if each plate consists of 2 different capital letters (not 0) one at each end and a number (not using 0) less than 100,000 between the end letters.
5. How many 4-digit numbers greater than 5000 can be formed using the digits 0, 2, 3, 4, 8, 9 (no repetition of digits)?
6. How many numbers of 4 digits each can be formed from the digits 0, 2, 3, 5, 6, 9? Of these how many are even? How many are divisible by 5?
7. In how many relative orders can 8 people be seated at a round table?
8. How many different 9-bead necklaces can be made from 9 different colored beads? (necklace has no clasp).
9. In how many relative orders can 4 men and 4 women be seated at a round table if men and women are to alternate?
10. In how many ways can 3 girls and 2 boys sit in a row of 5 seats if the boys are not to sit together?
11. How many different numbers of 8 digits each can be formed by the use of three 1's, two 4's, one 5, and two 7's.



12. From the digits 1 through 9, all possible numbers of 5 digits are formed. How many are divisible by 5?
13. In how many ways can 4 different novels and 3 different mystery books be arranged in a row on a shelf, if books of the same variety are to be side by side?

Answers to supplementary problems.

1.  $6 \cdot 5 \cdot 4 \cdot 3 = 360$

2.  $6 \cdot 5 \cdot 4 \cdot 3 = 360$

3.  $6 \cdot 6 = 36$

4.  $25 \cdot 9 \cdot 9 \cdot 9 \cdot 9 \cdot 9 \cdot 24 = 59,999,400$

5.  $2 \cdot 5 \cdot 4 \cdot 3 = 120$

6. (a)  $5 \cdot 5 \cdot 4 \cdot 3 = 300$

(b)  $\frac{5 \cdot 4 \cdot 3 \cdot 1}{\text{ending in } 0} + \frac{4 \cdot 4 \cdot 3 \cdot 2}{\text{not ending in } 0} = 156$

(c)  $\frac{5 \cdot 4 \cdot 3 \cdot 1}{\text{ending in } 0} + \frac{4 \cdot 4 \cdot 3 \cdot 1}{\text{ending in } 5} = 108$

7. Since the placement of the first person at any one of the 8 chairs will not change the relative order of the people, the placement of the other seven are only to be considered. Hence  $7! = 5040$ .

8.  $\frac{8!}{2} = 20,160$ .

9.  $3! \cdot 4!$  The placement of the first man or first woman does not matter after seating the first man or woman there are  $4!$  ways of placing the 4 men or women and  $3!$  ways of placing the rest of the sex seated first.

10. The number of ways of placing the 5 people without regard to order is  $5!$ . The number of ways of placing them so that

the boys sit together is  $(2 \cdot 1 \cdot 3 \cdot 2 \cdot 1) \cdot 4$  hence the number of ways where the boys do not sit together is  $5! - 2 \cdot 1 \cdot 3 \cdot 2 \cdot 1 \cdot 4 = 72$ .

11.  $\frac{8!}{3! 2! 2!} = 1680$ .

12.  $8 \cdot 7 \cdot 6 \cdot 5 \cdot 1$

13.  $4! \cdot 3! \cdot 2 = 288$ .

5.4 The Power Set of a Set and 5.5 Number of Subsets of a Given Size (Time: 4 days at least)

Before considering the problem of finding the number of subsets having  $r$  elements that can be formed from a set having  $n$  elements, we consider the more general problem of finding the power set of a set. The power set of a set  $S$ , denoted  $\mathcal{P}(S)$ , is the set whose elements are the subsets of  $S$ . Thus  $\mathcal{P}(S)$  contains all of the  $r$ -member subsets of a set  $S$ , with  $n$  elements, where  $r \leq n$ .  $\mathcal{P}(S)$  is developed inductively making use of mapping diagrams and CP' and  $n(\mathcal{P}(S))$  is found to be  $2^n$ . Then for any  $r$  and  $n$  with the above restrictions, the set, whose members are the  $r$ -member subsets of  $S$ , is a subset of  $\mathcal{P}(S)$ . For sets with a reasonably small finite cardinal number of members, it is easy enough to tabulate the power set and thus find the number of  $r$ -member subsets for any  $r \leq n$ . However, since this is not always practicable, a general formula is developed to find the number of  $r$ -member subsets as mentioned above.

In example 2,  $\binom{5}{2}$  refers to the number of subsets having 2

elements which can be formed from a set having 5 elements. Traditionally in the literature this has been called the number of combinations of 5 things taken 2 at a time. However, we introduce this idea in terms of sets and mappings and CP in order to relate to the rest of the course; also, the word "combinations" does little to elucidate the concept. In this particular example the number of one-to-one mappings of the set  $\{1, 2\}$  to the 2-member subset  $\{a, b\}$  of the 5-member set  $\{a, b, c, d, e\}$  is found to be  $2!$ . Since  $2!$  would be the number of such mappings from any 2 - member subset of the above 5 - member set, the product of  $2!$  and  $\binom{5}{2}$ , the number of 2 - member subsets, would give the total number of mappings of a 2 - member set to a 5 - member set. Since we have already learned that this is  $(5)_2$ , the counting principle yields:

$$\begin{aligned} 2! \binom{5}{2} &= (5)_2 \\ \text{Furthermore, } \binom{5}{2} &= \frac{(5)_2}{2!} = \frac{5 \cdot 4}{2 \cdot 1} = 10. \end{aligned}$$

Then another specific case is developed to find the number of 3-member subsets of a 7-member set. The formula for the general case of finding the number of  $r$ -member subsets of an  $n$ -member set then becomes an exercise in proof.

Since it is often easier to compute the number of  $(n - r)$  member subsets than the number of  $r$ -member subsets, and since these two numbers are the same for a given  $r$  and  $n$ , we have another theorem to prove:  $\binom{n}{r} = \binom{n}{n - r}$

### 5.6 Exercises

1. 35

2. 792

3.  $2^6 = 64$ ; 20

4. (a) 35

(b) 792

(c) 20

5. (a) 56

(b)  $8 \cdot 7 \cdot 6 = 336$

6. (a)  $\binom{5}{2} + \binom{5}{3} = \binom{6}{3}$

$$\frac{5 \cdot 4}{2} + \frac{5 \cdot 4 \cdot 3}{3 \cdot 2} = \frac{6 \cdot 5 \cdot 4}{3 \cdot 2}$$

$$10 + 10 = 20$$

(b)  $\binom{n}{m-1} + \binom{n}{m} =$  For all  $m \leq n$

$$= \frac{n(n-1)\dots(n-(m-1)+1)(n-m+1)!}{(m-1)!} + \frac{n(n-1)\dots(n-m+1)(n-m)!}{(m)!} + \frac{n(n-1)\dots(n-m+1)(n-m)!}{(n-m)!}$$

$$= \frac{n(n-1)\dots(n-(m-1)+1)}{(m-1)!} + \frac{n(n-1)\dots(n-m+1)}{m!}$$

$$= \frac{n(n-1)\dots(n-m+2)}{(m-1)!} + \frac{n(n-1)\dots(n-m+1)}{m!}$$

$$= \frac{n(n-1)\dots(n-m+2)}{(m-1)!} + \frac{n(n-1)\dots(n-m+2)(n-m+1)}{m(m-1)!}$$

$$= \frac{m[n(n-1)\dots(n-m+2)]}{m(m-1)!} + \frac{[n(n-1)\dots(n-m+2)](n-m+1)}{m(m-1)!}$$

$$= \frac{(m+n-m+1)(n(n-1)\dots(n-m+2))}{m!}$$

$$= \frac{(n+1)(n)(n-1)\dots(n-m+2)}{m!} \cdot \frac{[(n+1) - m]!}{[(n+1) - m]!}$$

$$= \frac{(n+1)(n)(n-1)\dots((n+1)-m+1)((n+1)-m)!}{m! ((n+1)-m)!}$$

$$= \frac{(n+1)!}{m! ((n+1) - m)}$$

$$= \binom{n+1}{m}$$

Q.E.D.

7. (a)  $\binom{x-1}{y} + \binom{x-1}{y+1} = \binom{x}{y+1}$

(b) Since  $y \leq x-1 \wedge y+1 \leq x-1 \wedge y+1 \leq x$   
 then  $x \geq y+1 \wedge x \geq y+2 \wedge x \geq y+1$   
 therefore  $x \geq y+2$

8. If  $n \geq 0$   $\binom{n}{0} = \frac{n!}{(n-0)! 0!} = \frac{n!}{n! 1!} = \frac{n!}{n!} = 1$

9.

A	1	1	1	1
1	2	3	4	5
1	3	6	10	15
1	4	10	20	35
1	5	15	35	70
				B

Problem No. 10 should have been eliminated from text and each of the problem numbers following be decreased by 1.

10. If  $n \geq 0 \implies \binom{n}{1} = \frac{n!}{(n-1)! 1!} = \frac{n(n-1)!}{(n-1)!} = n$

11. If  $n = 4 \implies \sum_{r=0}^4 \binom{4}{r} = \binom{4}{0} + \binom{4}{1} + \binom{4}{2} + \binom{4}{3} + \binom{4}{4}$   
 $1 + 4 + 6 + 4 + 1$   
 $= 16 \quad \text{or} \quad 2^4.$

12. (a) Since this is a problem of finding the number of subsets of a set with  $n$  elements, one can simply observe that selecting any subset is a matter of making one of two possible choices for each of the  $n$  elements. In other words, for each of the  $n$  elements, one selects or rejects. The Counting Principle shows that the number of ways of making this set of selections is:



17. There are 2 choices of an image for each of the 3 elements in the domain. Therefore, by CP the number of mappings is  $2^3 = 8$ .

18. In this case you have a choices for the image of each of b elements. By CP the number of possible mappings is  $a^b$ .

19. (a) Since each pair of the four nodes determines a path, the number of paths in each graph is the number of pairs that can be selected from 4 nodes.

This is  $\binom{4}{2}$  and the number for the two graphs is  $2 \cdot \binom{4}{2}$ .

(b) Since each of the 4 nodes in Graph I is connected to each of the 4 nodes in Graph II, the CP gives  $4 \cdot 4$  or 16 additional paths to complete the graph for 8 nodes.

(c) Since each pair of the 8 nodes determines a path, there are  $\binom{8}{2}$  or  $\binom{2 \cdot 4}{2}$  paths in the new graph.

(d) We started with 2 graphs each of 4 nodes, and  $\binom{4}{2}$  paths. Then we added 16 paths to complete the 8-node graph. The result would be the number of paths in an 8-node graph:

$$2 \cdot \binom{4}{2} + 4^2 = \binom{8}{2} \text{ or,}$$

$$12 + 16 = 28$$

20. (a)  $2 \binom{5}{2} + 5^2 = \binom{2 \cdot 5}{2}$

(b)  $2 \binom{n}{2} + n^2 = \binom{2 \cdot n}{2}$

(c)  $\binom{6}{2} + \binom{4}{2} + 6 \cdot 4 = \binom{6+4}{2}$  or

$15 + 6 + 24 = 45$

(d)  $\binom{n}{2} + \binom{m}{2} + n \cdot m = \binom{n+m}{2}$ .

21. Show that  $2 \binom{n}{2} + n^2 = \binom{2n}{2} \iff n(n-1) + n^2 = n(2n-1)$

$$\frac{2(n)(n-1)}{2} + n^2 = \frac{2n(2n-1)}{2}$$

$$n(n-1) + n^2 = n(2n-1)$$

$$n^2 - n + n^2 = n(2n-1)$$

$$2n^2 - n = n(2n-1)$$

$$n(2n-1) = n(2n-1)$$

$$n(n-1) + n^2 = n(2n-1)$$

$$n^2 - n + n^2 = n(2n-1)$$

$$2n^2 - n = n(2n-1)$$

$$n(2n-1) = n(2n-1)$$

hence the original statements are equivalent.

22. (a) Using the axioms of the affine geometry in chapter III it is easy to show that any one of the lines with  $k$  points will be intersected by each of a set of  $k$  mutually parallel lines in each of the  $k$  points. This gives  $k^2$  points. The question remains to show that these are all of the points of  $\pi$ . Adding another point will force you to add another point to each line and another line to each point if you don't wish to violate the parallel axiom. See the teaching guide on affine geometry for more detailed information on the geometric aspects.



(b) There are  $k^2$  points and  $k + 1$  lines on each point. If you form the product,  $k^2(k + 1)$ , you will be counting each line  $k$  times, since there are  $k$  points on each line. So one must divide  $k^2(k + 1)$  by  $k$  giving  $k(k + 1)$  lines in  $\pi$ .

(b) First alternate solution.

If there are  $k^2$  points in space then you can take  $\binom{k^2}{2}$  (2 element subsets) to name lines in space, however there will be  $\binom{k}{2}$  of these pairs that will name the same lines. Therefore the actual number of lines in space will be:

$$\begin{aligned} \frac{\binom{k^2}{2}}{\binom{k}{2}} &= \frac{\frac{k^2(k^2 - 1)}{2}}{\frac{k(k - 1)}{2}} = \frac{k^2(k^2 - 1)}{k(k - 1)} \\ &= \frac{k \cdot k(k + 1)(k - 1)}{k(k - 1)} = k(k + 1). \end{aligned}$$

(b) Second alternate solution:

Every line contains  $k$  points there are  $k + 1$  lines that pass through each of these  $k$  points (by axiom 3 and theorem 11 of affine geometry chapter 3 of Course III). Hence there are  $k(k + 1)$  lines in space.

23.  $r! \binom{n}{r} = (n)_r$ , where  $r \leq n$  and  $r, n \in \mathbb{Z}^+$ . Consider the one-to-one mappings of a set,  $A$ , of  $r$  members onto an  $r$ -member subset of a set,  $B$ , of  $n$  members. We already know that there are  $r!$  such mappings. Therefore for each  $r$ -member subset of  $B$  there are  $r!$  one-to-one mappings of  $A$  to such a subset. The number of  $r$ -member subsets of  $B$

is  $\binom{n}{r}$ . Therefore the total number of one-to-one mappings of A to B is  $r! \binom{n}{r}$ . But by definition, the number of such mappings is  $(n)_r$ . Therefore  $r! \binom{n}{r} = (n)_r$ .

$$24. \binom{n}{n-r} = \frac{n!}{(n-r)! (n-(n-r))!} = \frac{n!}{(n-r)! r!} = \frac{n!}{r! (n-r)!} = \binom{n}{r}$$

Therefore,  $\binom{n}{n-r} = \binom{n}{r}$ .

The following are additional word problems relating to combinations and their answers to be used at the discretion of the teacher.

#### Combinations

1. How many triangles can be drawn if their vertices are chosen from 10 points, no 3 points are collinear?
2. How many parallelograms are formed if a set of 4 parallel lines intersects another set of 6 parallel lines?
3. From a suit of 13 cards, how many hands of 5 cards each can be dealt to a player?
4. In Number 3, how many of these hands must include a king?
5. In how many ways can a hostess select 6 luncheon guests from 10 women if she must avoid having 2 particular women together?
6. From a group of 6 men in how many ways can you choose a committee of at least 4 men?
7. If 2 dice are tossed, in how many ways can a sum of 6 be thrown?
8. How many combinations of 3 letters each can be formed from 5 given distinct letters if repetitions are allowed?
9. In how many ways can 6 objects be divided into 2 equal groups?

10. If 6 coins are tossed together, in how many ways will  
(a) all fall heads? (b) just 2 fall heads?
11. If 7 coins are tossed together, in how many ways can they fall with at most 3 heads?
12. One bag contains 6 white and 8 black balls. A second bag contains 3 white and 6 black balls. How many ways can 6 balls consisting of 4 black and 2 white balls be drawn if all the balls must come from the same bag?
13. How many distinguishable combinations can be formed from the digits (2, 2, 2, 3, 4, 5, 6) taken 3 at a time?
14. From the digits (1, 2, 3, 4, 5, 6, 7) how many numbers of 4 different digits each can be formed if each number must contain 2 odd and 2 even digits?

Answers to Problems on Combination

1.  $\binom{10}{3} = \frac{10 \cdot 9 \cdot 8}{3 \cdot 2} = 120$

2.  $\binom{4}{2}\binom{6}{2} = 6 \cdot 15 = 90$

3.  $\binom{13}{5} = \frac{13 \cdot 12 \cdot 11 \cdot 10 \cdot 9}{5 \cdot 4 \cdot 3 \cdot 2 \cdot 1} = 1287$

4.  $\binom{12}{4} = \frac{12 \cdot 11 \cdot 10 \cdot 9}{4 \cdot 3 \cdot 2 \cdot 1} = 495$

5.  $\binom{10}{6} - \binom{8}{4} = 140$  or  $2\binom{8}{5} + \binom{8}{6} = 112 + 28 = 140$   
any 6 always includes 2

6.  $\binom{6}{4} + \binom{6}{5} + \binom{6}{6} = 15 + 6 + 1 = 22.$

7.  $(1, \textcircled{2})$   $(2, \textcircled{2})$   $(3, \textcircled{1})$  5 ways.

8. none repeated + one repeated twice + one repeated 3 times

$$\binom{5}{3} + \binom{5}{1} \binom{1}{1} \binom{4}{1} + \binom{5}{1} \binom{1}{1} \binom{1}{1} = 10 + 20 + 5 = 35.$$

9.  $\frac{\binom{6}{3} \binom{3}{3}}{2!} = 10$

10. (a) 1 (b)  $\binom{6}{2} = \frac{6 \cdot 5}{2 \cdot 1} = 15$

11. all tails + one head + 2 heads + 3 heads

$$\binom{7}{7} + \binom{7}{1} \binom{6}{6} + \binom{7}{2} \binom{5}{5} + \binom{7}{3} \binom{4}{4} = 1 + 7 + 21 + 35 = 64.$$

12.  $\binom{8}{4} \cdot \binom{6}{2} + \binom{6}{4} \cdot \binom{3}{2} = 1095.$

13. 3 - 2's + 2 - 2's + 1 - 2 + no. 2's.

$$\binom{3}{3} + \binom{2}{2} \cdot \binom{4}{1} + \binom{1}{1} \binom{4}{2} + \binom{4}{3} = 1 + 4 + 6 + 4 = 15$$

14.  $\binom{4}{2} \cdot \binom{3}{2} \cdot 4! = 432.$

### 5.7 The Binomial Theorem (Time: 4 days)

The ideas in this section that lead to a statement of the binomial theorem are from those that have already been presented in this chapter on combinatorics along with mapping diagrams and examples.

In particular the sequence of ideas and activities is as follows:

- (a) Raising a binomial to the 5th power by multiplication and observing not only the difficulty but also certain resulting patterns;

- (b) Raising a binomial to a power by repeated applications of the distributive property and examining the result which is the sum of products broken down into factors a and b;
- (c) Observing that the same products could have been found by selecting just one of a or b from each of the binomial factors and illustrating all such selections with mapping diagrams.
- (d) The combinatoric form of the theorem is then developed through considering the number of mappings in which the second term in the binomial is the image of each particular number from 0 to n.
- (e) This is then summarized in summation form and several examples are given.

The material in this section should be mostly self-explanatory but discussion and experimenting will be helpful to students.

### 5.8 Exercises

1.  $(3+2)^2 = 5^2 = 25$

$$3^2 + 2(3)(2) + 2^2 = 9 + 12 + 4 = 25$$

2.  $(1+2)^3 = 3^3 = 27$

$$1^3 + 3(1)^2(2) + 3(1)(2)^2 + 2^3 = 1 + 6 + 12 + 8 = 27$$

3. (a)  $a^4 + 4a^3b + 6a^2b^2 + 4ab^3 + b^4$

(b)  $x^6 + 6x^5y + 15x^4y^2 + 20x^3y^3 + 15x^2y^4 + 6xy^5 + y^6$

(c)  $c^7 + 7c^6d + 21c^5d^2 + 35c^4d^3 + 35c^3d^4 + 21c^2d^5 + 7cd^6 + d^7$

(d)  $a^{10} + 10a^9b + 45a^8b^2 + 120a^7b^3 + 210a^6b^4 + 252a^5b^5 +$

$$210a^4b^6 + 120a^3b^7 + 45a^2b^8 + 10ab^9 + b^{10} .$$

4. (a)  $a^3 - 3a^2b + 3ab^2 - b^3$

(b)  $x^4 - 4x^3y + 6x^2y^2 - 4xy^3 + y^4$

(c)  $a^5 - 5a^4b + 10a^3b^2 - 10a^2b^3 + 5ab^4 - b^5$

(d)  $x^6 - 6x^5y + 15x^4y^2 - 20x^3y^3 + 15x^2y^4 - 6xy^5 + y^6$

5. 11 .

6.a.  $(x+1)^3 = x^3 + 3x^2(1) + 3x(1)^2 + (1)^3$

$$= x^3 + 3x^2 + 3x + 1$$

b.  $(x-1)^3 = x^3 - 3x^2(1) + 3x(1)^2 - (1)^3$

$$= x^3 - 3x^2 + 3x - 1$$

7.a.  $(x+2)^4 = x^4 + 4x^3(2) + 6x^2(2)^2 + 4x(2)^3 + (2)^4$

$$= x^4 + 8x^3 + 24x^2 + 32x + 16.$$

b.  $(x-2)^4 = x^4 - 8x^3 + 24x^2 - 32x + 16.$

c.  $(x-\frac{1}{2})^4 = x^4 - 2x^3 + \frac{3}{2}x^2 - \frac{1}{2}x + \frac{1}{16}$

8.a.  $(2x+1)^5 = 32x^5 + 16x^4 + 8x^3 + 4x^2 + 2x + 1$

b.  $(2x - 1)^5 = 32x^5 - 16x^4 + 8x^3 - 4x^2 + 2x - 1$

9.a.  $1x^{20} - 20x^{19} + 190x^{18}$

b.  $1x^8 + 4x^7 + 7x^6$

c.  $-128x^7 - 64x^6 - 32x^5$

10.  $(1+1)^n = \binom{n}{0} 1^n + \binom{n}{1} 1^{n-1}(1) + \dots + \binom{n}{n} 1^n$

$$= \binom{n}{0} + \binom{n}{1} + \dots + \binom{n}{n} = 2^n .$$

The above sum is the number of subsets of a set with n elements

From previous work we know that this is  $2^n$ .

11. (a)  $(1.01)^5 = 1.0510100501$  .

(b)  $(.99)^5 = 0.9509900499$  .

12. For  $n = 1$  this becomes  $(1+x)^1 \geq 1 + 1x$  which is true.

For  $n = 2$  this becomes  $(1+x)^2 \geq 1 + 2x$  or  $1 + 2x + x^2 \geq 1 + 2x$  .

This is also true since  $x^2 \geq 0$ .

Then for all  $n$  greater than 2, the first two terms of the expansion on the left will be  $1 + nx$  and in addition there will be other terms all of which will be positive. Therefore the expression on the left will represent a number greater than or equal to the number represented by the expression on the right for all  $x \geq 0$  and positive values of  $n$ .

13. We shall consider the task of selecting exactly one of the two numbers  $a$  or  $b$  from each of the six factors  $(a+b)$  in  $(a+b)^6$ . Since the number of times  $a$  is selected is uniquely determined by the number of times  $b$  is selected in performing the above task, we can find the coefficients of the binomial expansion by finding the number of ways that  $b$  can be selected 0 times, 1 time, etc. up to 6 times.

The number of ways that  $b$  may be selected from 0 of the 6 factors is  $\binom{6}{0}$  or 1. But this is the same as selecting  $a$  from each of the 6 factors producing  $a^6$  for which the coefficient will then be 1 or  $\binom{6}{0}$  . Therefore the first term in the binomial expansion will be

$$\binom{6}{0} a^6 .$$

The other terms may be found in a similar manner giving:

$$\binom{6}{0} a^6 + \binom{6}{1} a^5 b + \binom{6}{2} a^4 b^2 + \binom{6}{3} a^3 b^3 + \binom{6}{4} a^2 b^4 + \binom{6}{5} a b^5 + \binom{6}{6} b^6$$

is can be summarized as:  $(a+b)^6 = \sum_{r=0}^6 \binom{6}{r} a^{6-r} b^r$  .

5.9 Mathematical Induction (Time: At least 5 days)

The first example stated in the text was designed to make students wary of generalizing too quickly; in particular, generalizing on the validity of a finite number of cases. It might be meaningful and dramatic to ask various members of the class to replace  $n$ , in the expression  $n^2 - n + 41$ , by natural numbers from 1-41 (at least). Have the group observe that you really do generate primes until  $n = 41$ . An interesting group discussion question might be:

How can you predict, before replacement, that  $n^2 - n + 41$  is composite when  $n = 41$ ? Could any quadratic expression,  $ax^2 + bx + c$ , generate only primes when  $x$  is successively replaced by natural numbers?

The first problem in the text that leads into PMI is to prove that for every  $n$ ,

$$1 + 2 + 3 + \dots + n = \frac{n(n+1)}{2}.$$

Students may legitimately question the verification of such a formula for very large  $n$ . The text does this only for  $n = 8$  and  $n = 11$ . How might we informally justify such a seemingly magical result? If you consider the sum in question, written two different ways,

$$1 + 2 + 3 + \dots + i + \dots + n \quad \text{and}$$
$$\underline{n + (n - 1) + (n - 2) + \dots + (n - i + 1) + \dots + 1}$$

and add you get  $(n + 1) + (n + 1) + (n + 1) + \dots + (n + 1) + \dots + (n + 1)$ .



Thus,  $2(1 + 2 + 3 + \dots + n) = (n + 1) + (n + 1) + \dots + (n + 1) = n(n + 1)$ . Consequently,  $1 + 2 + 3 + \dots + n = \frac{n(n + 1)}{2}$ .

Though this method, attributed to Gauss, does suggest the result, there is a concealed use of mathematical induction; one has to apply PMI to show that

$$\sum_{i=1}^n i = \sum_{i=1}^n (n - i + 1) \text{ and that}$$

$$\begin{aligned} \sum_{i=1}^n i + \sum_{i=1}^n (n - i + 1) &= \sum_{i=1}^n [i + (n - i + 1)] \\ &= n(n + 1). \end{aligned}$$

The domino effect was included as a visual aid to explain PMI. It must be emphasized that the dominoes have to be properly oriented and space for the effect to be applicable. The situation is summarized as:

1. The first domino falls down
2. If a particular domino falls, then the next one falls too.
3. (Therefore), all dominoes fall down.

Translated into mathematical terms, say in terms of a sequence of statements  $f_1, f_2, \dots, f_n, \dots$  the argument takes the form:

- (1)  $f_1$  is true. ( $f_n$  can be verified for  $n = 1$ )
- (2) Whenever  $f_k$  is true, then  $f_{k+1}$  is true too.

(Whenever  $f_n$  can be verified for  $n = k$ , it can also be verified for  $n = k + 1$ ).

- (3) (Therefore)  $f_n$  is true, for every  $n \in \mathbb{Z}^+$ .

The pedagogical difficulty that must be recognized here is that the arguments above are not logically sound; in other words, the use of the word "therefore" is not justified by logic. The acceptance of the "conclusion" must be considered as the acceptance of a hitherto unobserved property of the natural numbers. This means that we take the principle of mathematical induction as an axiom of the natural numbers. This was precisely what Peano did in his characterization of the natural numbers.

Following Peano, we consider a set  $N$  and a function  $g: N \rightarrow N$  (the set of natural numbers  $N$  and the successor function  $g$ ) such that:

Axiom 1. for each natural number  $n \in N$ , there is a unique successor  $g(n) \in N$  (the next natural number).

Axiom 2. If  $m, n \in N$  and  $m \neq n$ , then  $g(m) \neq g(n)$ .

Axiom 3. There is a unique natural number, denoted as 1, that is not the successor of any natural number.

Axioms 1, 2, and 3 simply state that  $g$  is a 1-1 mapping of  $N$  onto  $N \setminus \{1\}$ . Now, the principle of mathematical induction assumes the form:

Axiom 4. If  $S \subset N$  such that  $1 \in S$  and  $k \in S \rightarrow g(k) \in S$ , then  $S = N$ .

To show the necessity of postulating "mathematical induction" to characterize the natural numbers (up to isomorphism); that is, to show that Axiom 4 does not follow logically from Axioms 1, 2, and 3; it is sufficient to exhibit a set  $N_1 \neq N$  for

which Axioms 1, 2, and 3 are true but for which Axiom 4 is not true.

Let  $Z = \{(a, b): a \in N \text{ and } b \in N\}$ .  $Z \cap N = \emptyset$ .

Let  $N_1 = N \cup Z$  and define the successor function  $g_1: N_1 \rightarrow N_1$  as follows:

If  $n \in N_1$ , then  $n \in N$  or  $n \in Z$ .

If  $n \in N$ , define  $g_1(n) = g(n)$  where  $g$  is the successor function of  $N$ .

If  $n \in Z$ , then  $n = (p, q)$  where  $p, q \in N$ .

Define  $g_1(n) = g_1(p, q) = (p + 1, q)$ .

Verify that  $N_1$  and  $g_1$  satisfy Axioms 1, 2, and 3. To show that Axiom 4 is not true, consider  $S = N$ . Now  $1 \in S$  and  $k \in S \rightarrow (k + 1) \in S$ . However,  $S \neq N_1$ . The principle of mathematical induction does not characterize  $N_1$  and is seen to be independent of Axioms 1, 2, and 3. Starting with the Peano axioms and general set-theoretic principles, it is possible to go on to construct the integers, rational numbers, real numbers, and complex numbers.

If one is willing, however, to begin with the real number system, then the natural numbers may be defined in such a way that the principle of mathematical induction becomes a theorem. This, of course, is not the position taken in the text. It is presented solely as background material for the instructor.

Beginning with  $R$ , the set of Reals, we define:

Definition 1. If  $x \in R$ , then  $x + 1$  is called the successor of  $x$ .

Definition 2. If  $S \subset R$ , then  $S$  is called a successor subset of  $R$  if and only if:

(a)  $1 \in S$

(b)  $S$  contains the successor of each of its members. ( $x \in S \rightarrow (x+1) \in S$ ).

Observe that there are many sets that are successor subsets of  $R$  as well as many that are not.  $R$ , itself;  $Q$ , the set of rational numbers and  $Z$ , the set of integers are all successor subsets of  $R$ . On the other hand, the set of irrational numbers, the even integers, and the prime numbers are not.

Theorem 1. The intersection of any collection of successor subsets of  $R$  is a successor subset of  $R$ .

Proof. Let  $S_1, S_2, S_3, \dots, S_\alpha, \dots$  be a collection of successor subsets of  $R$ . Let  $P = \bigcap S_\alpha$ .

$1 \in S_\alpha$ , for each  $\alpha$ , since  $S_\alpha$  is a successor subset of  $R$ . Thus  $1 \in P$ . Let  $k \in P$ . This means that  $k \in S_\alpha$ , for every  $\alpha$ . But again, since each  $S_\alpha$  is a successor subset of  $R$ ,

$(k + 1) \in S_\alpha$ . Thus,  $(k + 1) \in P$ . We have shown that

(a)  $1 \in P$

(b)  $k \in P \rightarrow (k + 1) \in P$ .

This means that  $P$  is a successor subset of  $R$ .

Definition 3. Let  $N$  be the intersection of all successor subsets of  $R$ . The members of  $N$  are called natural numbers.

By Theorem 1,  $N$  itself is a successor subset of  $R$ . Though the definition avoids naming the elements of  $N$ ,  $N$  must include precisely the elements  $1, 1+1, 1+1+1$  etc. The principle of mathematical induction, phrased in the language of "successor subsets," may now be stated as a theorem.

Theorem 2. Let  $N$  be the set of natural numbers. If  $S \subset N$  and if  $S$  is a successor subset of  $R$ , then  $S = N$ .

Proof. It is given that  $S \subset N$ . Now,  $S$  is a successor subset of  $R$  and, by Definition 3,  $N$  is the intersection of all successor subsets of  $R$ . Thus,  $N \subset S$ . Consequently,  $S = N$ .

The text states the principle of mathematical induction in set-theoretic language (PMI) and in terms of a sequence of statements (PMI<sup>1</sup>). The definition of a sequence will have to be reviewed. Since the domain of a sequence is always  $Z^+$ , it is customary to describe the sequence by its terms (range values)  $f_1, f_2, \dots, f_n, \dots$ . In the context of this section, the student is concerned only with sequences whose codomains consist entirely of statements; hence the expression "sequence of statements." In Course IV, Chapter 2, the emphasis will be on sequences of numbers; that is on sequences whose codomains consist of real numbers. The student should have some experience approaching a problem through PMI and through PMI<sup>1</sup> but neither orientation should be emphasized as being intrinsically more acceptable.

Students will probably need help in interpreting statements such as  $1 + 2 + 3 + \dots + n = \frac{n(n+1)}{2}$  or  $2 + 4 + 6 + \dots + 2n = n(n+1)$ ; in particular, what do such statements mean when  $n = 1$ . Also, in going from the assumption that  $f_k$  is true to the proof that  $f_{k+1}$  is true, there may be some difficulty transforming the statement  $f_k$  into the statement  $f_{k+1}$ . Adding a particular term to both sides of an equation is not a magical process, reserved for mathematicians. This, in fact, is a good opportunity to review the student's present algebraic skills and to prepare him for the next chapter.

The Exercises in Section 5.10 illustrate the necessity of both conditions in the principle of mathematical induction. Though the greater effort is usually invested in the second condition ( $k \in S \rightarrow (k+1) \in S$ ), the first condition ( $1 \in S$ ) is equally as important. Exercise 4 is a simple but striking example that this is so.

Don't expect all students to understand mathematical induction the first time around. Now that it is included in Course III, it will be relied on frequently in subsequent course work. Students will have many opportunities to ponder over this principle and to apply it to a great variety of mathematical situations.

5.10 Solutions

1. (a) Prove  $\sum_{i=1}^n 7a_i = 7 \sum_{i=1}^n a_i$

Let  $S = \{x: x \in \mathbb{Z}^+ \text{ and } \sum_{i=1}^x 7a_i = 7 \sum_{i=1}^x a_i\}$

Since  $\sum_{i=1}^1 7a_i = 7a_1$  and  $7 \sum_{i=1}^1 a_i = 7 \cdot a_1$ ,  $1 \in S$ .

Assume  $k \in S$  and show  $k + 1 \in S$ .  $k \in S$  implies

$$7a_1 + 7a_2 + \dots + 7a_k = 7(a_1 + a_2 + \dots + a_k)$$

Add  $7a_{k+1}$  to both sides.

$$\begin{aligned} 7a_1 + 7a_2 + \dots + 7a_k + 7a_{k+1} &= 7(a_1 + a_2 + \dots + a_k) + 7a_{k+1} \\ &= 7(a_1 + a_2 + \dots + a_k + a_{k+1}) \end{aligned}$$

Thus,  $k + 1 \in S$ .

By PMI,  $S = \mathbb{Z}^+$ .

(b) Prove:

$$1^2 + 2^2 + 3^2 + \dots + n^2 = \frac{n(n+1)(2n+1)}{6} \text{ for every } n \in \mathbb{Z}^+.$$

Define the sequence of statements  $f_1, f_2, \dots, f_n, \dots$  where  $f_n$  is the statement  $1^2 + 2^2 + \dots + n^2 = \frac{n(n+1)(2n+1)}{6}$ .

Since  $\frac{1(1+1)(2 \cdot 1 + 1)}{6} = \frac{1(2)(3)}{6} = 1 = 1^2$  we may say

that  $f_1$  is true.

Assume  $f_k$  is true and show that  $f_{k+1}$  is true

$$1^2 + 2^2 + \dots + k^2 = \frac{k(k+1)(2k+1)}{6}$$

Add  $(k+1)^2$  to both sides.

$$\begin{aligned} 1^2 + 2^2 + \dots + k^2 + (k+1)^2 &= \frac{k(k+1)(2k+1)}{6} + (k+1)^2 \\ &= \frac{k(k+1)(2k+1) + 6(k+1)^2}{6} \\ &= \frac{(k+1)[(k(2k+1) + 6(k+1))]}{6} \\ &= \frac{(k+1)(2k^2 + 7k + 6)}{6} \\ &= \frac{(k+1)(k+2)(2k+3)}{6} \\ &= \frac{(k+1)((k+1) + 1)(2(k+1) + 1)}{6} \end{aligned}$$

Thus  $f_{k+1}$  is true.

By PMI<sup>1</sup>,  $f_n$  is true for every  $n \in \mathbb{Z}^+$ .

(c) Prove:

$$\frac{1}{2} + \frac{1}{3} + \frac{1}{4} + \dots + \frac{1}{2^n} < n.$$

Since  $\frac{1}{2} < 1$ , we see that  $f_1$  is true.

Assume  $f_k$  is true and show that  $f_{k+1}$  must be true.



$f_k$  is the statement  $\frac{1}{2} + \frac{1}{3} + \frac{1}{4} + \dots + \frac{1}{2^k} < k$

and  $f_{k+1}$  is the statement

$$\frac{1}{2} + \frac{1}{3} + \frac{1}{4} + \dots + \frac{1}{2^k} + \underbrace{\frac{1}{2^{k+1}} + \frac{1}{2^{k+2}} + \dots + \frac{1}{2^{k+1}}}_{2^k \text{ terms}} < k+1$$

where the number of terms added to the left hand side of  $f_k$  is  $2^k$ . To prove  $f_{k+1}$  true we must show that the sum of these  $2^k$  terms is less than 1

$$\text{i.e. } \frac{1}{2^{k+1}} + \frac{1}{2^{k+2}} + \dots + \frac{1}{2^{k+1}} < 1.$$

Since each term on the left is less than  $\frac{1}{2^k}$ ,

$$\underbrace{\frac{1}{2^{k+1}} + \frac{1}{2^{k+2}} + \dots + \frac{1}{2^{k+1}}}_{2^k \text{ terms}} < \underbrace{\frac{1}{2^k} + \frac{1}{2^k} + \dots + \frac{1}{2^k}}_{2^k \text{ terms}}$$

which is equal to  $2^k \cdot \frac{1}{2^k} = 1$ .

Therefore,

$$\frac{1}{2^{k+1}} + \frac{1}{2^{k+2}} + \dots + \frac{1}{2^{k+1}} < 1$$

Thus,

$$\frac{1}{2} + \frac{1}{3} + \frac{1}{4} + \dots + \frac{1}{2^k} + \frac{1}{2^{k+1}} + \dots + \frac{1}{2^{k+1}} < k+1.$$

Consequently  $f_{k+1}$  is true.

By PMI<sup>1</sup>, the statement  $f_n$  is true, for every  $n \in \mathbb{Z}^+$ .

(d) Using PMI to prove that  $\frac{6^n - 2^n}{4} \in \mathbb{N}$  for every  $n \in \mathbb{Z}^+$

Let  $S = \{x: x \in \mathbb{Z}^+ \text{ and } \frac{6^x - 2^x}{4} \in \mathbb{N}\}$

Since  $\frac{6^1 - 2^1}{4} = \frac{4}{4} = 1$   $1 \in \mathbb{Z}^+ \Rightarrow 1 \in S$ .

Assume that  $k \in S$  and show that  $k + 1 \in S$ .

Let  $\frac{6^k - 2^k}{4} = p$  where  $p \in \mathbb{N}$

then  $6^k - 2^k = 4p$ ,

and  $6^k = 4p + 2^k$ .

$$\begin{aligned} \frac{6^{k+1} - 2^{k+1}}{4} &= \\ &= \frac{6 \cdot 6^k - 2 \cdot 2^k}{4} \\ &= \frac{6(4p + 2^k) - 2 \cdot 2^k}{4} \\ &= \frac{24p + 6 \cdot 2^k - 2 \cdot 2^k}{4} \\ &= \frac{24p + 2^k(6 - 2)}{4} \\ &= \frac{24p + 2^k(4)}{4} \\ &= \frac{4(6p + 2^k)}{4} \end{aligned}$$

$$= 6p + 2^k$$

Since  $6p + 2^k \in \mathbb{Z}^+$  then  $k + 1 \in S$ .

Hence by PMI  $S = \mathbb{Z}^+$ .

(e) Prove that  $\frac{n(n+1)}{2}$  is a natural number for every  $n \in \mathbb{Z}^+$ .

Define the sequence of statements  $f_1, f_2, \dots, f_n, \dots$

where  $f_n$  is the statement

$$\frac{n(n+1)}{2} \text{ is a natural number.}$$

Since  $\frac{1(1+1)}{2} = \frac{1(2)}{2} = 1$  and 1 is a natural number, we may say that  $f_1$  is true.

Let us assume  $f_k$  is true and prove that  $f_{k+1}$  is true.

$$\frac{k(k+1)}{2} = p, \text{ where } p \text{ is a natural number.}$$

$$\begin{aligned} \text{Now } \frac{(k+1)[(k+1)+1]}{2} &= \frac{(k+1)(k+2)}{2} = \frac{(k+1)k}{2} + \frac{(k+1)(2)}{2} \\ &= p + (k+1) \end{aligned}$$

Since  $p \in \mathbb{Z}^+$  and  $(k+1) \in \mathbb{Z}^+$ ,  $p + (k+1) \in \mathbb{Z}^+$ .

Thus  $f_{k+1}$  is true.

By PMI,  $f_n$  is true, for every  $n$ .

(f) Prove  $\frac{1}{3} + \frac{1}{9} + \frac{1}{27} + \dots + \frac{1}{3^n} = \frac{1}{2}(1 - \frac{1}{3^n})$  for every  $n \in \mathbb{Z}^+$ .

$$\text{Let } S = \{x : x \in \mathbb{Z}^+ \text{ and } \frac{1}{3} + \frac{1}{9} + \dots + \frac{1}{3^x} = \frac{1}{2}(1 - \frac{1}{3^x})\}$$

Since  $\frac{1}{2}(1 - \frac{1}{3^1}) = \frac{1}{2}(\frac{2}{3}) = \frac{1}{3}$ , we may say that  $1 \in S$ .

Let us assume that  $k \in S$  and show that  $(k+1) \in S$ .

$$\frac{1}{3} + \frac{1}{9} + \frac{1}{27} + \dots + \frac{1}{3^k} = \frac{1}{2}(1 - \frac{1}{3^k})$$

Add  $\frac{1}{3^{k+1}}$  to both sides.

$$\frac{1}{3} + \frac{1}{9} + \frac{1}{27} + \dots + \frac{1}{3^k} + \frac{1}{3^{k+1}} = \frac{1}{2}(1 - \frac{1}{3^k}) + \frac{1}{3^{k+1}}$$

$$\begin{aligned} &= \frac{1}{2} \left( 1 - \frac{1}{3^k} + \frac{2}{3^{k+1}} \right) \\ &= \frac{1}{2} \left( 1 - \frac{3}{3^{k+1}} + \frac{2}{3^{k+1}} \right) \\ &= \frac{1}{2} \left[ 1 - \left( \frac{3-2}{3^{k+1}} \right) \right] \\ &= \frac{1}{2} \left[ 1 - \frac{1}{3^{k+1}} \right] \end{aligned}$$

Thus,  $(k + 1) \in S$ .

By PMI,  $S = \mathbb{Z}^+$ .

(g) Prove:  $1 + 2 + 4 + 8 + \dots + 2^{n-1} = 2^n - 1$  for every  $n \in \mathbb{Z}^+$ .

Let  $f_1, f_2, \dots, f_n, \dots$  be a sequence of statements where  $f_n$  is the statement:

$$1 + 2 + 4 + 8 + \dots + 2^{n-1} = 2^n - 1$$

Since  $1 = 2^1 - 1$  we may say that  $f_1$  is true.

Let us assume  $f_k$  is true and show that  $f_{k+1}$  is true.

$$1 + 2 + 4 + 8 + \dots + 2^{k-1} = 2^k - 1$$

Add  $2^k$  to both sides

$$\begin{aligned} 1 + 2 + 4 + 8 + \dots + 2^{k-1} + 2^k &= 2^k - 1 + 2^k \\ &= 2^k + 2^k - 1 \\ &= 2 \cdot 2^k - 1 \\ &= 2^{k+1} - 1 \end{aligned}$$

Thus,  $f_{k+1}$  is true.

By PMI,  $f_n$  is true, for every  $n \in \mathbb{Z}^+$ .

2. Let  $A_1, A_2, \dots, A_k$  be non-empty sets and let  $n(A_i) = r_i$  for  $i = 1, 2, \dots, k$ , where each  $r_i \in \mathbb{Z}^+$ . Let  $A_1 \times A_2 \times \dots \times A_k = \{(a_1, a_2, \dots, a_k) : a_i \in A_i \text{ } i = 1, 2, \dots, k\}$ .

Then,  $n(A_1 \times A_2 \times \dots \times A_k) = r_1 \cdot r_2 \cdot \dots \cdot r_k$ .

Define the sequence of statements  $f_1, f_2, \dots, f_k, \dots$

where  $f_k$  is the statement:

$$n(A_1 \times A_2 \times \dots \times A_k) = r_1 \cdot r_2 \cdot \dots \cdot r_k \text{ (assuming that } n(A_i) = r_i \text{)}$$

Since  $n(A_1) = r_1$ , the statement  $f_1$  is true.

Let us assume that  $f_k$  is true and show that  $f_{k+1}$  is true

$$n(A_1 \times A_2 \times \dots \times A_k) = r_1 \cdot r_2 \cdot \dots \cdot r_k$$

Now  $A_1 \times A_2 \times \dots \times A_k \times A_{k+1} = \{(a_1, a_2, \dots, a_k, a_{k+1})$  where  $a_i \in A_i$  for  $i = 1, 2, \dots, k + 1\}$ . The  $(k + 1)$  tuple  $(a_1, a_2, \dots, a_k, a_{k+1})$  may be viewed as the adjuncting of  $a_{k+1}$  to the  $k$ -tuple  $(a_1, a_2, \dots, a_k)$ . In this way, we see that we form the elements of  $A_1 \times A_2 \times \dots \times A_{k+1}$  by adjuncting the elements of  $A_{k+1}$ , one at a time, to the elements of  $A_1 \times A_2 \times \dots \times A_k$ . If two elements in  $A_1 \times A_2 \times \dots \times A_k$  are distinct, then the adjuncting of an element in  $A_{k+1}$  to each will product two distinct elements in  $A_1 \times A_2 \times \dots \times A_k \times A_{k+1}$ . Since  $n(A_1 \times A_2 \times \dots \times A_k) = r_1 \cdot r_2 \cdot \dots \cdot r_k$  and  $n(A_{k+1}) = r_{k+1}$ , the number of elements in  $A_1 \times A_2 \times \dots \times A_k \times A_{k+1}$  is  $(r_1 \cdot r_2 \cdot r_3 \cdot \dots \cdot r_k) \cdot r_{k+1} = r_1 r_2 r_3 \cdot \dots \cdot r_k \cdot r_{k+1}$ . Thus,  $f_{k+1}$  is true. By PMI<sup>1</sup>,  $f_k$  is true, for every  $k \in \mathbb{Z}^+$ .

3. When one reasons by "induction," one reaches his conclusions based upon the verification of a finite number of cases (hopefully large). We observed, in the text, that the inferences drawn through inductively reasoning are not always conclusive; that is, inductive reasoning does not constitute mathematical "proof." The Principle of Mathematical Induction is a postulate about the natural numbers, which permits generalizations to be made about all natural numbers under specified conditions (PMI or PMI<sup>1</sup>).

4.  $T = \{n: n \in \mathbb{Z}^+ \text{ and } n = n + 1\}$

Let  $k \in T$ . This means that  $k \in \mathbb{Z}^+$  and

(1)  $k = k + 1$ . Add 1 to both sides of (1).

$$k + 1 = (k + 1) + 1.$$

This means that  $(k + 1) \in T$ .

We may not conclude that  $T = \mathbb{Z}^+$  since we cannot show that  $1 \in T$ .

5. Let  $S = \{n: n \in \mathbb{Z}^+ \text{ and the number of diagonals in a polygon of } n \text{ sides is } \frac{n(n-3)}{2}\}$ . If  $n = 3$ , the polygon is a triangle --no diagonals may be drawn. In the case  $n = 3$ ,

$$\frac{n(n-3)}{2} = \frac{3(3-3)}{2} = 0; \text{ we see that } 3 \in S.$$

Let us assume that  $k \in S$  and show that  $(k + 1) \in S$ .

We are assuming that in a polygon of  $k$  sides,  $\frac{k(k-3)}{2}$

diagonals may be drawn. Suppose the polygon in Figure 1

has  $k$  sides.

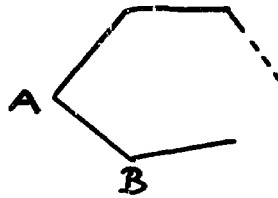

Figure 1

If we now have  $(k + 1)$  sides, we have one addition vertex, say  $X$ . This is illustrated in Figure 2.

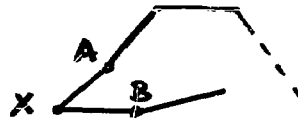

Figure 2

Each diagonal that can be drawn in Figure 1 can be drawn in Figure 2. The side  $\overline{AB}$  in Figure 1 is now a diagonal of Figure 2. Thus, we gain one diagonal. In addition, we may connect  $X$  and any vertex other than  $A$  or  $B$  to form a new diagonal in the polygon of Figure 2. This produces  $(k - 2)$  new diagonals.

Thus, the total number of diagonals in Figure 2 is

$$\begin{aligned}
 \frac{k(k-3)}{2} + 1 + (k-2) &= \frac{k(k-3)}{2} + k - 1 \\
 &= \frac{k(k-3) + 2(k-1)}{2} \\
 &= \frac{k^2 - 3k + 2k - 2}{2} \\
 &= \frac{k^2 - k - 2}{2} \\
 &= \frac{(k+1)(k-2)}{2} \\
 &= \frac{(k+1)[(k+1) - 3]}{2}
 \end{aligned}$$

Thus,  $k + 1 \in S$ .

By PMI (modified),  $S$  contains every natural number  $x \geq 3$ .

6. Prove or disprove the assertion:

For every natural number  $n$ ,  $2^n > 3n$ .

When  $n = 1$ ,  $2^1 = 2$  and  $3n = 3$ . Thus, the assertion is not true for every natural number. Table 1 reveals that

$n$	$2^n$	$3n$
1	2	3
2	4	6
3	8	9
4	16	12
5	32	15

the assertion seems to be true, beginning with  $n = 4$ .

Let  $S = \{n : n \in \mathbb{Z}^+ \text{ and } 2^n > 3n\}$ .

We know  $1 \notin S$ ,  $2 \notin S$ ,  $3 \notin S$ , but  $4 \in S$ .

Let us assume that  $k \in S$  and show that  $(k + 1) \in S$ .

We assume  $2^k > 3k$ .

Now,  $2^{k+1} = 2 \cdot 2^k > 2 \cdot 3k = 3k + 3k > 3k + 3 = 3(k + 1)$ .

Thus,  $(k + 1) \in S$ .

By the modified Principle of Mathematical Induction, we may say that  $S$  contains every natural number  $n \geq 4$ .

7. Let  $f_1, f_2, f_3, \dots, f_n, \dots$  be a sequence of statements where  $f_n$  is the statement

$$a + ar + ar^2 + \dots + ar^n = \frac{a(1 - r^{n+1})}{1 - r} \text{ for } r \neq 1.$$

$$\begin{aligned} \text{Since } \frac{a(1 - r^{1+1})}{1 - r} &= \frac{a(1 - r^2)}{1 - r} = \frac{a(1 + r)(1 - r)}{1 - r} \\ &= a(1 + r) = a + ar, \end{aligned}$$

we see that  $f$  is true.

Let us assume  $f_k$  is true and show that  $f_{k+1}$  is true.



- 198 -

$$a + ar + ar^2 + \dots + ar^k = \frac{a(1 - r^{k+1})}{1 - r}$$

Add  $ar^{k+1}$  to both sides.

$$\begin{aligned} a + ar + ar^2 + \dots + ar^k + ar^{k+1} &= \frac{a(1 - r^{k+1})}{1 - r} + ar^{k+1} \\ &= \frac{a(1 - r^{k+1}) + ar^{k+1}(1 - r)}{1 - r} \\ &= \frac{a[1 - r^{k+1} + r^{k+1} - r^{k+1} \cdot r]}{1 - r} \\ &= \frac{a(1 - r^{(k+1)+1})}{1 - r} \end{aligned}$$

Thus,  $f_{k+1}$  is true.

By PMI<sup>1</sup>, we conclude that  $f_n$  is true, for every  $n \in \mathbb{Z}^+$ .

8. a. Assertion  $x^3 - x = 0$

Let  $S = \{n: n \in \mathbb{Z}^+ \text{ and } n^3 - n = 0\}$ .

Since  $1^3 - 1 = 0$ ,  $1 \in S$ .

Assume  $k \in S$  and try to show that  $(k + 1) \in S$ .

$k^3 - k = 0$  or  $k^3 = k$ .

$$\begin{aligned} (k + 1)^3 - (k + 1) &> k^3 + 1 - (k + 1) = k^3 + 1 - k - 1 \\ &= k^3 - k = 0. \end{aligned}$$

Since  $(k + 1)^3 - (k + 1) > 0$ , then  $(k + 1)^3 > k + 1$ .

Thus,  $(k + 1) \notin S$ .

PMI fails to be satisfied.

b. We may say that the statement  $f_n$ : if  $10|n$ , then  $10|n + 10$  is true for each  $n \in \mathbb{Z}^+$ .

The form of this statement is  $(P \Rightarrow Q) \Rightarrow R$ .

We must show that  $R$  is false since  $P \Rightarrow Q$  is always true.

Therefore if we show that  $1 \notin T$  then  $T \neq \mathbb{Z}^+$  and

therefore  $R$  is false, because PMI is not satisfied.

Since  $10 \nmid 1$  then  $1 \notin T$  hence  $T \neq \mathbb{Z}^+$ .

c.  $3 + 5 + 7 + \dots + (2n + 1) = n^2 + 2$  for every  $n \in \mathbb{Z}^+$ .

Let  $S = \{n : n \in \mathbb{Z}^+ \text{ and } 3 + 5 + 7 + \dots + (2n + 1) = n^2 + 2\}$ .

Since  $3 = 1^2 + 2$ , we may say that  $1 \in S$ .

Assume that  $k \in S$  and try to show that  $(k + 1) \in S$ .

$$3 + 5 + 7 + \dots + (2k + 1) = k^2 + 2$$

Add  $2(k + 1) + 1$  to both sides.

$$\begin{aligned} 3 + 5 + 7 + \dots + (2k + 1) + [2(k + 1) + 1] \\ &= k^2 + 2 + [2(k + 1) + 1] \\ &= k^2 + 2k + 5 \\ &= k^2 + 2k + 1 + 4 \\ &= (k + 1)^2 + 4. \end{aligned}$$

Thus,  $k + 1 \notin S$ .

PMI fails to be satisfied.

8. d.  $100n \geq n^2$  for every  $n \in \mathbb{Z}^+$ .

Let  $S = \{n : n \in \mathbb{Z}^+ \text{ and } 100n \geq n^2\}$ .

Since  $100(1) \geq 1^2$ , we see that  $1 \in S$ .

Assume that  $k \in S$  and try to show that  $(k + 1) \in S$ ;

that is, assume  $100k \geq k^2$  and show that

$$100(k + 1) \geq (k + 1)^2.$$

$$\begin{aligned} 100(k + 1) - (k + 1)^2 &= 100k + 100 - (k^2 + 2k + 1) \\ &= (100k - k^2) + 99 - 2k. \end{aligned}$$

By hypothesis, we know that  $100k - k^2 \geq 0$ . However,

we cannot say that  $99 - 2k \geq 0$ . We are unable to

conclude that  $100(k + 1) - (k + 1)^2 \geq 0$ .

Thus, we cannot show that  $(k + 1) \in S$ .

Of course, the counter-example  $n = 101$  also shows that

$100n \geq n^2$  is false.

9. For every  $n \in \mathbb{Z}^+$ ,  $2n \leq 2^n$ .

I. Let  $S = \{n: n \in \mathbb{Z}^+ \text{ and } 2n \leq 2^n\}$

Since  $2 \cdot 1 \leq 2^1$ ,  $1 \in S$ .

Assume  $k \in S$  and show that  $k + 1 \in S$ .

Assume  $2k \leq 2^k$ .

$$\begin{aligned} \text{Now } 2(k + 1) &= 2k + 2 \leq 2^k + 2 \leq 2^k + 2^k = 2 \cdot 2^k \\ &= 2^{k+1}. \end{aligned}$$

Thus,  $k + 1 \in S$ .

By PMI,  $S = \mathbb{Z}^+$ .

II. Let  $f_1, f_2, f_3, \dots, f_n, \dots$  be a sequence of statements where  $f_n$  is the statement:

$$2n \leq 2^n.$$

Since  $2 \cdot 1 \leq 2^1$ , the statement  $f_1$  is true.

Assume the statement  $f_k$  is true and show that  $f_{k+1}$  is true.

Assume  $2k \leq 2^k$ .

$$\begin{aligned} 2(k + 1) &= 2k + 2 \leq 2^k + 2 \leq 2^k + 2^k = 2 \cdot 2^k \\ &= 2^{k+1}. \end{aligned}$$

Thus,  $f_{k+1}$  is true.

By PMI, all the statements  $f_n$  in the sequence are true.

10. Prove that for every  $n \in \mathbb{Z}^+$ ,

$$\begin{aligned} 1 + 2 + 3 + \dots + n &= n + (n - 1) + (n - 2) + (n - 3) \\ &+ \dots + 1. \end{aligned}$$

Let  $f_1, f_2, f_3, \dots, f_n, \dots$  be a sequence of statements

where  $f_n$  is the statement:

$$\begin{aligned} 1 + 2 + 3 + \dots + n &= n + (n - 1) + (n - 2) + (n - 3) \\ &+ \dots + 1. \end{aligned}$$

$f_1$  is the statement  $1 = 1$ . Thus,  $f_1$  is true.

Assume  $f_k$  is true and show that  $f_{k+1}$  is true.

Assume  $1 + 2 + 3 + \dots + k = k + (k - 1) + (k - 2) + \dots + 1$

Add  $(k + 1)$  to both sides.

$$\begin{aligned} [1 + 2 + 3 + \dots + k] + (k + 1) \\ = [k + (k - 1) + (k - 2) + \dots + 1] + (k + 1) \\ = (k + 1) + [k + (k - 1) + (k - 2) + \dots + 1] \end{aligned}$$

replace each  $k$  by  $(k + 1) - 1$

$$\begin{aligned} \text{Thus, } 1 + 2 + 3 + \dots + k + (k + 1) \\ = (k + 1) + [[(k + 1) - 1] + ((k + 1) - 2) + (k + 1) - 3 + \dots +] \end{aligned}$$

Consequently  $f_{k+1}$  is true. By PMI<sup>1</sup>,  $f_n$  is true, for every  $n \in \mathbb{Z}^+$ .

5.11 Summary. (Time: 5.11, 5.12 = 2 days)

5.12 Review Exercises Solutions.

1. (a)  $6! = 6 \cdot 5 \cdot 4 \cdot 3 \cdot 2 \cdot 1 = 720$       (b)  $6^6 = 216 \cdot 216 = 46,656$
2.  $5 \cdot 6 \cdot 2 = 60$
3.  $1 \cdot \frac{3}{6} \cdot \frac{1}{2} = \frac{3}{12} = \frac{1}{4}$
4.  $1 \cdot 26 \cdot 26 \cdot 26 = 26^3 = 17,576$
5.  $2 \cdot 26^3 = 2 \cdot 17,576 = 35,152$
6.  $\binom{6}{2} = \frac{6!}{2!2!} = \frac{6 \cdot 5}{2 \cdot 1} = 15$  selections.
7.  $\binom{5}{2} = \frac{5!}{3!2!} = \frac{5 \cdot 4}{2 \cdot 1} = 10$  lines.
8.  $8 \cdot 7 \cdot 6 = 336$

9.  $\binom{8}{3} = \frac{8!}{5!3!} = \frac{8 \cdot 7 \cdot 6}{3 \cdot 2 \cdot 1} = 56$  committees.

10.

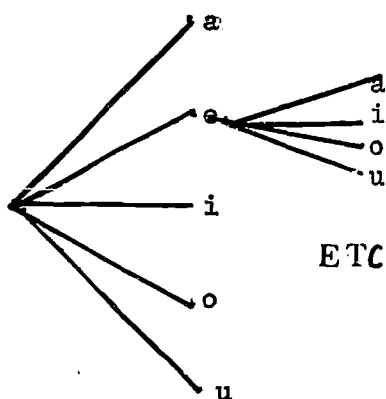

$5 \cdot 4 = 20$

11.  $\binom{7}{1} \cdot \binom{5}{1} = 7 \cdot 5 = 35$

12.  $9 \cdot 14 = 126$

13.  $9 \cdot 10 \cdot 10 = 900$

14. (a)  $9 \cdot 9 \cdot 8 = 728$  (b)  $9 \cdot 1 \cdot 1 = 9$  (c)  $900 - (728 + 9) = 163$

15. (a)  $(7)_5 = 2520$  (b)  $(5)_5 = 120$  (c)  $(8)_2 = 56$

16. (a)  $(8)_2 = 56$  (b)  $(10)_2 = 151,200$

17. (a)  $\binom{10}{3} = \frac{10!}{7!3!} = \frac{10 \cdot 9 \cdot 8}{3 \cdot 2} = 120$  (b)  $\binom{10}{7} = 120$

(c)  $\binom{10}{10} = 1$  (d)  $\binom{10}{1} = 1$  (e)  $\binom{10}{0} = \binom{10}{10-0} = \binom{10}{10} = 1$

18.  $\binom{5}{2} \cdot \binom{10}{2} = 10 \cdot 45 = 450$

19. (a)  $\binom{9}{2} = 36$  (b)  $\binom{11}{8} = 165$  (c)  $\binom{7}{6} = 7$

(d)  $\binom{6}{7} = 0$  (e)  $\binom{16}{0} = 1$

20.  $\binom{10}{8} = \binom{10}{2} = 45$  different ways

21.  $\binom{4}{1} \cdot \binom{5}{2} \cdot \binom{6}{2} = 600$

$$22. \binom{100}{5} = \frac{100 \cdot 99 \cdot 98 \cdot 97 \cdot 96}{5 \cdot 4 \cdot 3 \cdot 2 \cdot 1} = 75,287,520$$

$$23. \binom{8}{6} + \binom{8}{7} = \binom{9}{7}$$

$$24. (a + b)^4 = \binom{4}{0}a^4 + \binom{4}{1}a^3b + \binom{4}{2}a^2b^2 + \binom{4}{3}ab^3 + \binom{4}{4}b^4$$

$$= a^4 + 4a^3b + 6a^2b^2 + 4ab^3 + b^4$$

$$25. (a - b)^4 = a^4 - 4a^3b + 6a^2b^2 - 4ab^3 + b^4$$

$$26. (a + b)^n = \binom{n}{0}a^n + \binom{n}{1}a^{n-1}b^1 + \binom{n}{2}a^{n-2}b^2 + \binom{n}{3}a^{n-3}b^3 +$$

$$\binom{n}{4}a^{n-4}b^4 + \binom{n}{5}a^{n-5}b^5 + \binom{n}{6}a^{n-6}b^6 + \dots$$

$$27. (2u + v)^6 = 64u^6 + 192u^5v + 240u^4v^2 + 160u^3v^3 + 60u^2v^4 + 12uv^5 + v^6$$

$$28. \text{ Prove by induction } \sum_{k=1}^n \frac{k}{2^k} = 1 - \frac{n}{2^n}$$

Let  $f_1, f_2, \dots, f_n$  be a sequence of statements where  $f_n$  is the statement

$$\frac{1}{2^1} + \frac{2}{2^2} + \dots + \frac{n}{2^n} = 1 - \frac{n}{2^n}$$

Since  $\frac{1}{2^1} = 1 - \frac{1}{2^1} = \frac{1}{2}$ , we see that  $f_1$  is true.

Assume  $f_k$  is true and show  $f_{k+1}$  is true.

$$\text{Given: } \frac{1}{2^1} + \frac{2}{2^2} + \dots + \frac{k}{2^k} = 1 - \frac{k}{2^k}$$

$$\text{prove } \frac{1}{2^1} + \frac{2}{2^2} + \dots + \frac{k+1}{2^{k+1}} = 1 - \frac{k+1}{2^{k+1}}$$

$$\frac{1}{2^1} + \frac{2}{2^2} + \dots + \frac{k}{2^k} = 1 - \frac{k}{2^k}$$

adding  $\frac{k+1}{2^{k+1}}$  to both sides we have

$$\frac{1}{2^1} + \frac{2}{2^2} + \dots + \frac{k}{2^k} + \frac{k+1}{2^{k+1}} = 1 - \frac{k}{2^k} + \frac{k+1}{2^{k+1}}$$

$$= 1 - \left( \frac{k}{2^k} - \frac{k+1}{2^{k+1}} \right)$$

$$= 1 - \left( \frac{2k - (k+1)}{2^{k+1}} \right)$$

hence  $k+1 \notin S$  therefore the

$$= 1 - \left( \frac{k-1}{2^{k+1}} \right)$$

Second solution:

A counter example shows that this is only true for  $f_1$ .

For example let  $n = 2 \Rightarrow \frac{1}{2^1} + \frac{2}{2^2} \neq 1 - \frac{2}{2^2}$

$$\frac{1}{2} + \frac{1}{2} \neq 1 - \frac{1}{2}$$

$$1 \neq \frac{1}{2}$$

\*29.

$n(A) = x$	1	2	3	4	5	6
$n(B) = y$	720	NO	10	NO	6	6

Since  $6! = 720$ ,  $x = 6$  and  $y = 6$  will probably be an answer quickly given by the students. Since the maps must be 1:1,  $n(A) \leq n(B)$  and if  $n(A) > 6$  then there will be more than 720 permutations. Thus  $1 \leq n(A) \leq 6$ . You can use a table to find  $y$ -values for the possible values of  $x = 1, 2, 3, 4, 5, 6$ . If  $x = 3$ ,  $(y)_3 = y \cdot (y - 1) \cdot (y - 2) = 720$  and  $y = 10$ . Other  $x$ -values are examined in a similar fashion.

30.  $\binom{n}{2} = 15 \implies \frac{n(n-1)}{2} = 15 \implies n^2 - n = 30$  so  $n^2 - n - 30 = (n - 6)(n + 5) = 0$ .  $n = 6$

\*31. (a) a and (c or d),  $1 \cdot 3 = 3$  ways

(b) I. (a or c) and (b or d),  $3 \cdot 3 = 9$

II.  $2^3 - 1 = 7$

III.  $3 \cdot 7 = 21$  IV.  $2^5 - 1 = 31$

(c)  $n = 8$ ,  $2^n - 1 = 255$

Sample Test on Chapter V

(Time: 1 day)

I. Evaluate each of the following:

(a)  $(5)_8$

(b)  $(6)_7$

(c)  $(7)_3$

(d)  $(5)_{10}$

(e)  $\binom{6}{1}$

(f)  $\binom{23}{21}$

(g)  $\binom{8}{0}$

(h)  $\binom{10}{3}$

(i)  $\binom{9}{6}$

(j)  $\binom{4}{5}$

II. A set S has 6 elements.

(a) How many subsets does it have?

(b) How many proper subsets does it have?

(c) How many of its subsets has exactly 4 elements?

III. Expand:

(a)  $(p + q)^5$

(b)  $(a - 1)^4$

IV. For each of the following, tell how many one-to-one mappings are possible from set A to set B.

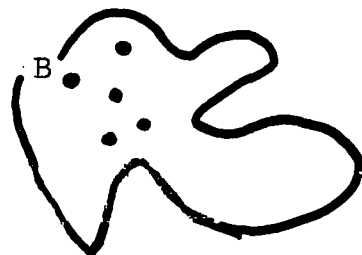
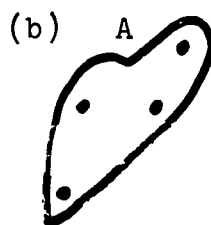
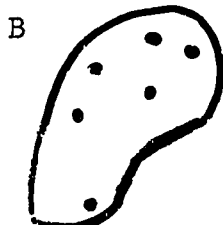
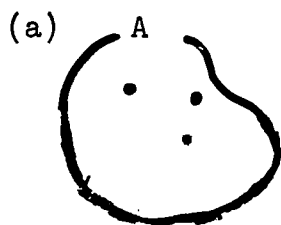

V. (a) How many four - digit numbers are there with the first digit not 0?

(b) How many four - digit numbers are there with no two digits alike (first digit not 0)?



NOTE: You do not have to multiply out the answers in problem VI - IX.

- VI. Five boys compete in a race. In how many ways can first and second places be won if there is no tie?
- VII. A carpenter needs 4 men and 10 men apply for the job. In how many ways can he pick out 4 men?
- VIII. Given ten points, no three of which are in a straight line, find the number of line segments that can be drawn by joining pairs of the points.
- IX. In how many ways can a teacher give out 9 grades of A in a class with 15 pupils?
- X. Use the binomial expansion to find  $(1.02)^4$ .
- XI. In the expansion of  $(x + y)^{12}$ , what is the complete term that contains  $x^9$ ? Give the coefficient as an integer.
- XII. Use PMI or PMI<sup>1</sup> to prove one of the following:
- (a)  $\frac{n(n+1)}{2}$  is a natural number for every  $n \in \mathbb{Z}^+$ .
- (b)  $\sum_{k=0}^n \frac{1}{2^k} = 1 - \frac{1}{2^{n+1}}$
- (c)  $\frac{5^n - 2^n}{3}$  is a natural number for every  $n \in \mathbb{Z}^+$ .

Bonus Question (optional)

1. Expand  $(x - 2y)^5$
2. Show that  $2 \cdot \binom{n}{2} + n^2 = \binom{2n}{2}$

Answers for Sample Test

I a)  $(5)_n = 5! = 5 \cdot 4 \cdot 3 \cdot 2 \cdot 1 = 120$

b)  $(6)_2 = \frac{6!}{5!} = 6$

c)  $(7)_3 = \frac{7!}{(7-3)!} = 7 \cdot 6 \cdot 5 = 210$

d)  $\binom{5}{5} = \frac{5!}{(5-5)!5!} = \frac{5!}{5!} = 1$

e)  $\binom{6}{1} = \frac{6!}{(6-1)! \cdot 1!} = \frac{6!}{5! \cdot 1!} = \frac{6!}{5!} = 6$

f)  $\binom{23}{21} = \binom{23}{2} = \frac{23!}{(23-2)!(2!)} = \frac{23 \cdot 22}{2 \cdot 1} = 253$

g)  $\binom{8}{0} = \frac{8!}{(8-0)!0!} = \frac{8!}{8!} = 1$

h)  $\binom{9}{3} = \frac{9!}{(9-3)!3!} = \frac{9!}{6!3!} = \frac{9 \cdot 8 \cdot 7}{3 \cdot 2 \cdot 1} = 84$

i)  $\binom{9}{5} = \binom{9}{3} = 84$  by h).

j)  $\binom{4}{5} = 0$  by def.

II a)  $n(\mathcal{P}(S)) = 2^6 = 64$

b) proper subsets =  $64 - 1 = 63$

c)  $\binom{6}{4} = \binom{6}{2} = \frac{6!}{4! \cdot 2!} = \frac{6 \cdot 5}{2 \cdot 1} = 15$

III a)  $(p + q)^5 = \binom{5}{0}p^5 + \binom{5}{1}p^4q + \binom{5}{2}p^3q^2 + \binom{5}{3}p^2q^3 +$

$$\binom{5}{4}pq^4 + \binom{5}{5}q^5$$

$$= p^5 + 5p^4q + 10p^3q^2 + 10p^2q^3 + 5pq^4 + q^5$$

$$\begin{aligned} \text{b) } (a - 1)^4 &= \binom{4}{0}a^4 - \binom{4}{1}a^3 + \binom{4}{2}a^2 - \binom{4}{3}a + \binom{4}{4} \\ &= a^4 - 4a^3 + 6a^2 - 4a + 1 \end{aligned}$$

$$\text{IV a) } (6)_3 = \frac{6!}{(6-3)!} = \frac{6!}{3!} = 6 \cdot 5 \cdot 4 = 120$$

$$\text{b) } (5)_4 = \frac{5!}{(5-4)!} = \frac{5!}{1!} = 5 \cdot 4 \cdot 3 \cdot 2 = 120$$

$$\text{V a) } 9 \cdot 10 \cdot 10 \cdot 10 = 9000$$

$$\text{b) } 9 \cdot 9 \cdot 8 \cdot 7 = 4536$$

$$\text{VI } 5 \cdot 4 = 20$$

$$\text{VII } \binom{10}{4} = \frac{10 \cdot 9 \cdot 8 \cdot 7}{4 \cdot 3 \cdot 2 \cdot 1} = 210$$

$$\text{VIII } \binom{10}{2} = \frac{10 \cdot 9}{2 \cdot 1} = 45$$

$$\begin{aligned} \text{IX } \binom{15}{9} &= \binom{15}{6} = \frac{15!}{(15-6)!6!} = \frac{15!}{9!6!} = \frac{15 \cdot 14 \cdot 13 \cdot 12 \cdot 11 \cdot 10}{6 \cdot 5 \cdot 4 \cdot 3 \cdot 2 \cdot 1} \\ &= 5005 \end{aligned}$$

$$\begin{aligned} \text{X } (1 + .02)^4 &= \binom{4}{0}1^4 + \binom{4}{1}1^3 \cdot (.02) + \binom{4}{2}1^2 \cdot (.02)^2 + \\ &\quad \binom{4}{3}1 \cdot (.02)^3 + \binom{4}{4}(.02)^4 \\ &= 1^4 + 4(.02) + 6(.0004) + 4(.000008) \\ &\quad + (.00000016) \\ &= 1 + .08 + .0024 + .000032 + .00000016 \\ &= 1.08243216 \end{aligned}$$

$$\text{XI } 4\text{th term} = \binom{12}{3}x^9y^3 = \frac{12 \cdot 11 \cdot 10}{3 \cdot 2 \cdot 1} = 220x^9y^3$$

$$\text{XII a) } \frac{1(1+1)}{2} = \frac{1 \cdot 2}{2} = 1, \text{ Since } 1 \in S$$

$$\text{assume } \frac{k(k+1)}{2} = p, \quad p \in \mathbb{Z}^+$$

prove  $\frac{(k+1)(k+1+1)}{2} \in \mathbb{Z}^+$

$$\begin{aligned}\frac{(k+1)(k+2)}{2} &= \frac{k^2 + 3k + 2}{2} = \frac{k^2 + k + 2k + 2}{2} \\ &= \frac{k(k+1) + 2(k+1)}{2} = \frac{k(k+1)}{2} + \frac{2(k+1)}{2} \\ &= \frac{k(k+1)}{2} + k + 1 \\ &= p + k + 1\end{aligned}$$

Since  $p, k,$  and  $1 \in \mathbb{Z}^+, p + k + 1 \in \mathbb{Z}^+$

Hence  $k + 1 \in S$  and  $S = \mathbb{Z}^+$

b) To prove  $\sum_{k=1}^n \frac{1}{2^k} = 1 - \frac{1}{2^n}$

Let  $S = \{x: x \in \mathbb{Z}^+ \text{ and } \sum_{k=1}^x \frac{1}{2^k} = 1 - \frac{1}{2^x}\}$

Since  $\sum_{k=1}^1 \frac{1}{2^k} = 1 - \frac{1}{2^1} = \frac{1}{2}, 1 \in S$

Assume  $k \in S. k \in S \implies \sum_{k=1}^k \frac{1}{2^k} = 1 - \frac{1}{2^k}$

To show  $k + 1 \in S,$  add  $\frac{1}{2^{k+1}}$  to both sides

$$\begin{aligned}\frac{1}{2^1} + \frac{1}{2^2} + \frac{1}{2^3} + \dots + \frac{1}{2^k} + \frac{1}{2^{k+1}} &= 1 - \frac{1}{2^k} + \frac{1}{2^{k+1}} \\ &= 1 - \left(\frac{2 - 1}{2^{k+1}}\right) \\ &= 1 - \frac{1}{2^{k+1}}\end{aligned}$$

Thus  $k + 1 \in S.$  Hence by PMI  $S = \mathbb{Z}^+.$

c) To prove  $\frac{5^n - 2^n}{3}$  is a natural number for every  $n \in \mathbb{Z}^+$

Define a sequence of statements  $f_1, f_2, \dots, f_n \dots$

where  $f_n = \frac{5^n - 2^n}{3}$  and  $f_n \in \mathbb{Z}^+$

Since  $\frac{5^1 - 2^1}{3} = \frac{5 - 2}{3} = \frac{3}{3} = 1$   $f_1$  is true.

Assume  $f_k$  is true,  $\frac{5^k - 2^k}{3} = p$ ,  $p \in \mathbb{Z}^+$

$$\frac{5^k - 2^k}{3} = p \implies 5^k - 2^k = 3p \implies 5^k = 3p + 2^k$$

Show that  $\frac{5^{k+1} - 2^{k+1}}{3} \in \mathbb{Z}^+$

$$\begin{aligned} \frac{5^{k+1} - 2^{k+1}}{3} &= \frac{5^k \cdot 5 - 2^k \cdot 2}{3} \\ &= \frac{5(3p + 2^k) - 2^k \cdot 2}{3} \\ &= \frac{15p + 5 \cdot 2^k - 2^k \cdot 2}{3} \\ &= \frac{15p + 2^k(5 - 2)}{3} \\ &= \frac{15p + 2^k(3)}{3} = 5p + 2^k \end{aligned}$$

Since  $5p + 2^k \in \mathbb{Z}^+$ ,  $\frac{5^{k+1} - 2^{k+1}}{3} \in \mathbb{Z}^+$

Hence  $f_{k+1}$  is true. By PMI,  $f_n$  is true for every  $n \in \mathbb{Z}^+$

### Bonus Questions

$$\begin{aligned} 1) (x - 2y)^5 &= \binom{5}{0}x^5 - \binom{5}{1}x^4 \cdot 2y + \binom{5}{2}x^3(2y)^2 - \\ &\quad \binom{5}{3}x^2(2y)^3 + \binom{5}{4}x(2y)^4 - \binom{5}{5}(2y)^5 \\ &= x^5 - 10x^4y + 40x^3y^2 - 80x^2y^3 + 80xy^4 \\ &\quad - 32y^5 \end{aligned}$$

2) To prove:  $2\binom{n}{2} + (n^2) = \binom{2n}{2}$

$$\frac{2 \cdot n(n-1)}{2} + \frac{2n^2}{2} = \frac{2n(2n-1)}{2}$$

$$2n(n-1) + 2n^2 = 2n(2n-1)$$

$$2n^2 - 2n + 2n^2 = 2n(2n-1)$$

$$4n^2 - 2n = 2n(2n-1)$$

$$2n(2n-1) = 2n(2n-1)$$

## Chapter 6

### PROBABILITY

Time Estimate: 12 - 15 days

#### General Remarks

Before they study Chapter 6 on probability it would be desirable that students have studied the probability in Course I, the statistics in Course II, and combinatorics in Course III. If the students do not have this background then the topics that should be presented, either before starting the chapter or as the topic is needed in the chapter, are as follows:

#### I. From Statistics:

- a) Frequency and cumulative tables and diagrams,
- b) Summation with emphasis on examples and symbolism,
- c) Perhaps the Chebyshev Inequality, since this is an important theorem and deals with relative frequency which in turn is closely related to probability.

#### II. From Combinatorics:

- a) The Counting Principle,
- b) Permutations, subsets (combinations) and Cartesian product,
- c) The power set of an outcome set,  $S$ ,
- d) Perhaps the Binomial Theorem in a combinatorics setting.

In general the purpose of this chapter is to use the intuitive

and experimental background from Course I and the statistics in Course II and combinatorics as a foundation on which to build a set theoretic approach to probability leading to the notion of a probability space. Then definitions and theorems related to a probability space are carefully developed. This material on a probability is the "keystone" of probability theory.

From the pedagogical viewpoint the extensive use made of graphics in the presentation is a most important feature of giving the student an understanding of the concepts before they are presented in a strictly theoretical setting. Proofs without preliminary motivation are usually difficult for secondary school students at the level for which this material is intended.

Some of the graphics used in this chapter are:

- a) Venn diagrams which are very good for illustrating relations among events,
- b) Arrow diagrams to illustrate functions,
- c) Tree diagrams to illustrate outcome sets and probabilities,
- d) One-dimensional, two-dimensional and three-dimensional Cartesian graphs are used extensively to illustrate outcome sets, events and relations defined on events,
- e) Although they are not presented in this chapter, there might be situations which arise in class where the teacher would want to use bar diagrams to illustrate a probability measure on the singletons of an outcome set.



Some important features of this chapter are:

- a) An occasional review of ideas at the beginning of a section to serve as a foundation for new ideas,
- b) Several examples worked out in detail and illustrated on the topic in each section,
- c) Proofs of difficult theorems are included in the text to avoid discouragement of some students,
- d) Use of terminology that is in the spirit of the latest terminology used by mathematicians,
- e) A chapter summary and review exercises.

## 6.1 Introduction

The purpose of the introduction is to give the student a little glimpse of the "humanities" side of mathematics by including some historical background related to probability and some indication of the usefulness of probability in fields other than mathematics.

## 6.2 Outcome Sets and Events (2 - 3 days)

The ideas in this section are, for the most part, not new to the students and are not very difficult. With the background that the students have had in sets and mappings along with the material in the Course I chapter on probability, much of the section will be review.

The power set of an outcome set may be a new idea, if the students have not covered the chapter on combinatorics. Also

using the terminology intersection event, union event, differences event, and complementary event may be new but is basic to the development of the chapter.

The method is to discuss, illustrate with diagrams, and give many examples of experiments, trials, outcomes, outcome sets, and events. The more this is the result of original student thinking the better.

The important goal here should be to follow up informal work in developing ideas with careful and precise definitions and to extend the ideas wherever possible. For example, the idea of disjoint sets is extended to three or more sets.

Some specifics in the chapter are:

- a) A short review of some basic terminology and notions used in probability experiments with finite outcome sets,
- b) Several worked out examples which the students should have chance to discuss,
- c) Experiments to perform such as the one with the peripatetic bug taking walks on the edges of a cube and the card matching experiment; in the card matching experiment a nice extension is for the teacher to have the students find the average number of matches for a set of trials with a particular size deck where it is a surprising discovery for the students to find that the average tends to be 1 for any size deck.

- d) The experiment of tossing two dice and finding the sums leads to the idea (later) of a random variable,
- e) Tossing three coins gives a nice opportunity to graph an outcome set and events in three dimensions,
- f) Other ideas are events as subsets, power set, singleton events, union events, intersection events, complementary events, difference events and disjoint sets for 2, 3 and  $n$  events.

### 6.3 Exercises

1.
  - a)  $\{(H, up), (H, down), (T, Up), (T, down)\}$
  - b)  $\{(rye, honey), (rye, marmalade), (rye, caviar), (wheat, honey), (wheat, marmalade), (wheat, caviar)\}$
  - c)  $\{(d < .99), (.99 \leq d \leq 1.01), (d > 1.01)\}$
  - d)  $\{(red, blue, h < 5'), (red, blue, 5' \leq h < 6'), (red, blue, h \geq 6'), \dots, (blonde, brown, h \geq 6')\}$
2.
  - a) Let urn I contain 1 red bead, 5 blue beads and 7 white beads; and urn II contain 2 black beads and 3 yellow beads. Then the experiment could be to first select one of the two urns and then select a bead from that urn. Several answers are possible, based on changes in the number of beads.
  - b) Selecting a flavor of ice-cream and then a sundae

topping.

- c) Selecting a girlfriend on the basis of weight. Or perhaps more accurately, classifying a set of girls on the basis of weight. I don't know why I am prejudiced in favor of girls. It could be boys or pigs or most anything that can be weighed!
- d) Tossing three coins or tossing one coin three times, etc.
- e) Forming two-letter "words" from the set of vowels without repetition.

3. a)  $A = \{H4, H2, H3, D4, D2, D3\}$   
 b)  $B = \{H3, D3, S3, C3\}$   
 c)  $A \cup B = \{H4, H2, H3, D4, D2, D3, S3, C3\}$   
 d)  $A \cap B = \{H3, D3\}$   
 e)  $\bar{A} = \{S4, S2, S3, C4, C2, C3\}$   
 f)  $A \setminus B = \{H4, H2, D4, D2\}$   
 g) Let  $C = \{H4, D4\}$ ;  $D = \{S4, C2, D3\}$ ;  $E = \{C4\}$ .

Then C, D and E are disjoint events since they are pairwise disjoint. There are many other solutions.

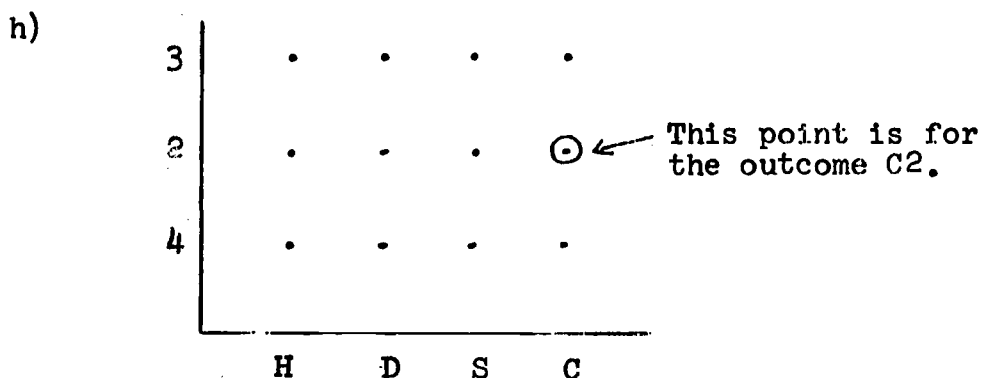

4. a)  $\{(1,1), (1,2), \dots, (4,3), (4,4)\}$   
 b)  $\{(2,4), (3,3), (4,2)\}$

c)  $\{(4,1), (4,2), (4,3), (4,4)\}$

d), e) and f)

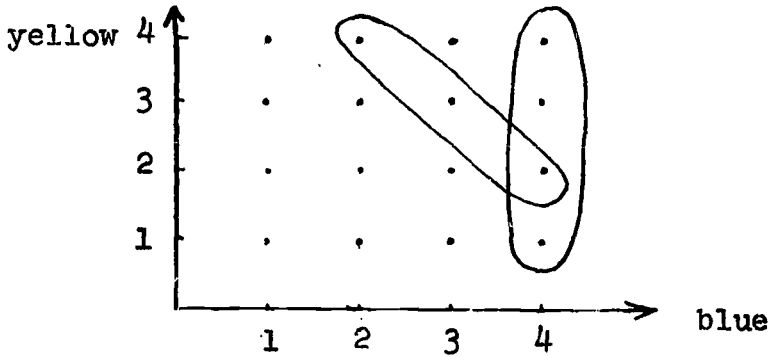

5. a)  $(\bar{A} \cap \bar{B} \cap \bar{C}) \cup (A \cap B \cap C)$ .  
 b)  $(\bar{A} \cap \bar{B} \cap C) \cup (A \cap B \cap \bar{C})$ .  
 c)  $(\bar{A} \cap B) \cup C$ .

a)

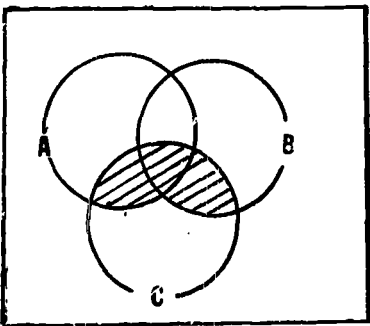

$(A \cup B) \cap C$

b)

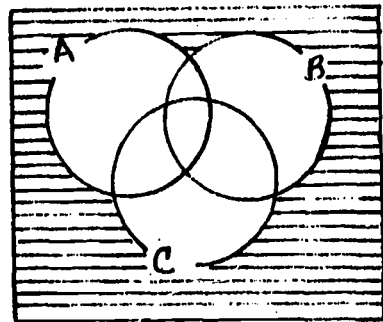

$\bar{A} \cap \bar{B} \cap \bar{C}$

Note: There should be some discussion on diagrams a and g. It should be related to distributivity of " $\cap$ " over " $\cup$ ".

c)

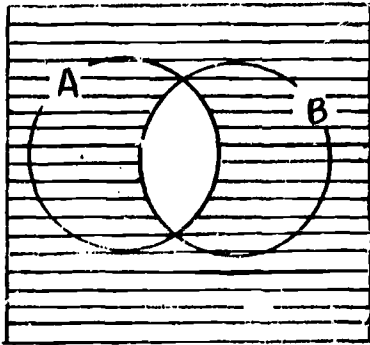

$$\overline{(A \cap B)}$$

d)

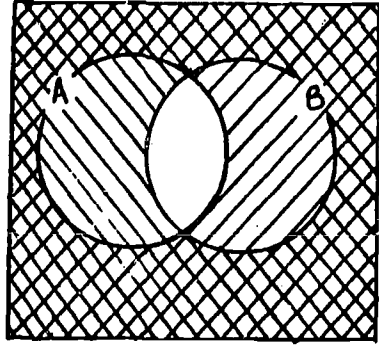

$$\overline{A} \cup \overline{B}$$

(all shaded regions included)

e)

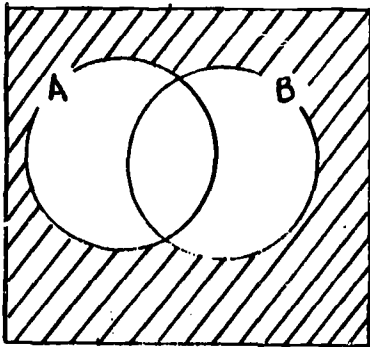

$$A \cup B$$

f)

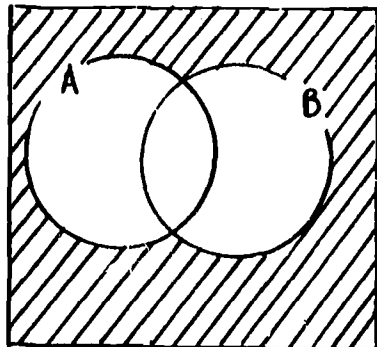

$$\overline{A \cup B}$$

(This can also be represented by the cross-hatched region in d above.)

7. The diagrams for c and d should have the same regions shaded even if they have been done in two different ways. One relationship statement might be, "The complement of the intersection of two events A and B is equal to the union of the complements of A and B." Another statement that would demonstrate good thinking would be, "If x is not in A and B, then it is not in A or it is not in B."
8. The diagrams for e and f should have the same regions shaded. Acceptable statements could be, "The complement of the union of two events A and B is the intersection of the complements of A and B." or "If x is not in A or B, then it is not in A and it is not in B."
9. Each event that includes the outcome a has occurred. That is, {a,b,c}, {a,b}, {a,c}, {a}.

#### 6.4 Probability Measure ( $2\frac{1}{2}$ - $3\frac{1}{2}$ days)

This section is perhaps one of the most important of the chapter because this is the first fairly formal presentation of ideas which are at the foundation of probability theory. Concepts such as a probability measure  $P$ , the probability of the event  $A$ ,  $P(A)$ , and a probability space,  $(S,P)$  should be discussed thoroughly in connection with the definitions and the examples. Additional examples should be given and students should be able to give original examples themselves if they understand the material.

Theorem 2 should be discussed carefully and each step should be related (in the students' thinking) with the properties of a

probability measure, the definitions, or parts of the theorem previously presented. Example 8 provides an opportunity to understand the theorem a little better by illustrating certain parts.

Theorem 3 gives a more general formula for the probability of the union of two events as it includes both the disjoint and non-disjoint cases. Here example 9 provides illustration. Property three of a probability measure is extended to the case of  $n$  events. This can be proved for  $n = 3$  by using associativity of union and addition. Then the case for  $n$  in general can be proved by induction. It might be better here to assume the case for  $n$  in general.

Other ideas of this section are that:

- a) Every event with 2 or more members can be expressed as the union of singletons (i.e., sets, each of which include exactly one of the outcomes in the event);
- b) These singletons are pair-wise disjoint;
- c) Thus using the extension of property 3 of a probability measure, the probability of an event is the summation of the probabilities of the singletons which are subsets of the event.

The probabilities of the singletons are called elementary probabilities.

Examples 1,2,3,4,5 and 6 in this section present probability measures where the probabilities of the singletons are not all equal. In example 7 the probability measure is uniform. That is, the elementary probabilities are all equal.



6.5 Exercises: Note that problem number 4 is not numbered in the text.

1. a) .3    b) .5    c) .8    d) .7    e) 0    f) 1

2. a) .40    b) .33    c) .45

3.  $\frac{7}{8}$

4. a) 64

b)  $(0, 0) \longrightarrow (0, 1) \longrightarrow (1, 1) \longrightarrow (1, 0)$

$(0, 0) \longrightarrow (0, -1) \longrightarrow (1, -1) \longrightarrow (1, 0)$

$(0, 0) \longrightarrow (1, 0) \longrightarrow (0, 0) \longrightarrow (1, 0)$

$(0, 0) \longrightarrow (0, 1) \longrightarrow (0, 0) \longrightarrow (1, 0)$

$(0, 0) \longrightarrow (-1, 0) \longrightarrow (0, 0) \longrightarrow (1, 0)$

$(0, 0) \longrightarrow (0, -1) \longrightarrow (0, 0) \longrightarrow (1, 0)$

$(0, 0) \longrightarrow (1, 0) \longrightarrow (2, 0) \longrightarrow (1, 0)$

$(0, 0) \longrightarrow (1, 0) \longrightarrow (1, 1) \longrightarrow (1, 0)$

$(0, 0) \longrightarrow (1, 0) \longrightarrow (1, -1) \longrightarrow (1, 0)$

c)  $\frac{9}{64}$

d)  $P(1, 0) = P(0, 1) = P(0, -1) = P(-1, 0) = \frac{9}{64}$

$P(1, -2) = P(1, 2) = P(-1, 2) = P(-1, -2) =$

$P(2, -1) = P(2, 1) = P(-2, 1) = P(-2, -1) = \frac{3}{64}$

$P(3, 0) = P(-3, 0) = P(0, 3) = P(0, -3) = \frac{1}{64}$

5. a)  $\frac{24}{64}$  (or  $\frac{3}{8}$ )

c)  $\frac{24}{64}$  (or  $\frac{3}{8}$ )

b)  $\frac{8}{64}$  (or  $\frac{1}{8}$ )

d)  $\frac{8}{64}$  (or  $\frac{1}{8}$ )

6. a)  $\frac{36}{64} = \frac{9}{16}$

b)  $\frac{28}{64} = \frac{7}{16}$

7. 1) Since  $\{a_1\}, \{a_2\}, \{a_3\}, \{a_4\}$  are events property 1 of a probability measure applies to each. Therefore for each  $a_i$ ,  $P(\{a_i\}) \geq 0$ .

Also  $S = \{a_1\} \cup \{a_2\} \cup \{a_3\} \cup \{a_4\}$

Therefore  $P(S) = P(\{a_1\} \cup \{a_2\} \cup \{a_3\} \cup \{a_4\})$  and since  $P(S) = 1$ , so does  $P(\{a_1\} \cup \{a_2\} \cup \{a_3\} \cup \{a_4\})$ .

But since the  $a_i$  are disjoint we have,

$$P(\{a_1\}) + P(\{a_2\}) + P(\{a_3\}) + P(\{a_4\}) = P(S) = 1.$$

- 2) The proof for the case of  $n$  outcomes is perfectly analogous except for slight changes in notation.

8. a) If  $x \in \{0, 1, 2\}$  then:

$\binom{2}{x}$  is non-negative;

if  $0 \leq p \leq 1$ , then  $p^x$  is non-negative

and  $(1-p)^{2-x}$  is non-negative.

Therefore  $\binom{2}{x} p^x (1-p)^{2-x}$  is non-negative and this satisfies the first condition.

For the next condition consider the summation, where  $x$  goes from 0 to 2 inclusive of  $\binom{2}{x} p^x (1-p)^{2-x}$

This can be expressed as:

$$(1-p)^2 + 2p(1-p) + p^2 = 1 - 2p + p^2 + 2p - 2p^2 + p^2 = 1$$

- b) In a manner similar to that in part a) it can be shown that for any  $n \in \mathbb{N}$  and any  $x \in \mathbb{N}$  from 0 to  $n$  inclusive, each of the expressed factors in  $\binom{n}{x} p^x (1-p)^{n-x}$  is non-negative provided that  $0 \leq p \leq 1$ . This satisfies condition 1 in Exercise 5.

To show that condition 2 is satisfied,  $\binom{n}{x} p^x (1-p)^{n-x}$  is the expression for a term of the expansion of the binomial

$[p+(1-p)]^n$ . But since  $p+(1-p) = 1$ , and  $1^n = 1$ . The summation where  $x$  goes from 0 to  $n$  for any  $n \in \mathbb{N}$ , of  $\binom{n}{x} p^x (1-p)^{n-x}$  is equal to 1.

9.a)  $1/4$       b)  $3/4$       c)  $9/16$       d)  $1/16$

10.a)  $.12$       b)  $.88$

11.a) If  $x$  is a member of  $A \cap B$ , then it is a member of  $A$ . So  $A \cap B$  is a subset of  $A$ .

Then by theorem 1d,  $P(A \cap B) \leq P(A)$ .

b) If  $x$  is a member of  $A$ , then  $x$  is a member of  $A \cup B$ . So  $A$  is a subset of  $A \cup B$ .

Again by theorem 1d,  $P(A) \leq P(A \cup B)$ .

c) From theorem 2,  $P(A \cup B) = P(A) + (P(B) - P(A \cap B))$ .

So  $P(A \cup B) + P(A \cap B) = P(A) + P(B)$

But since  $P(A \cap B) \geq 0$ ,  $P(A \cup B) \leq P(A) + P(B)$

12.  $.3$

13. The event that exactly one of  $A$  and  $B$  occurs, is the event  $[(A \setminus B) \cup (B \setminus A)]$ . And since  $(A \setminus B)$  and  $(B \setminus A)$  are disjoint,  $P[(A \setminus B) \cup (B \setminus A)] = P(A \setminus B) + P(B \setminus A)$ . Then using theorem 2c and substituting in the right side of the equation above we get  $P(A) - P(A \cap B) + P(B) - P(B \cap A)$ . Then rearranging the terms and using the fact that  $A \cap B = B \cap A$ , we get  $P(A) + P(B) - 2P(A \cap B)$ . That's it!!

14. If  $P(A) > .5$ , then  $P(\bar{A}) < .5$  since  $P(A) + P(\bar{A}) = 1$ . In this case  $P(A) > P(\bar{A})$  and therefore  $P(A)/P(\bar{A}) > 1$ . This means that  $O(A) > 1$ .

Now to go in the other direction, suppose  $O(A) > 1$ .

Then  $P(A)/P(\bar{A}) > 1$ , which means  $P(A) > P(\bar{A})$ .

Then since  $P(A) + P(\bar{A}) = 1$ ,  $P(A) > .5$ .

15. Proof:

1)  $P(A \cup B \cup C) = [P(A \cup B) \cup C]$ , since union of sets is associative.

2)  $P[(A \cup B) \cup C] = P(A \cup B) + P(C) - P[(A \cup B) \cap C]$ ; theorem 3.

3)  $P(A \cup B) = P(A) + P(B) - P(A \cap B)$ ; theorem 3.

4)  $(A \cup B) \cap C = (A \cap C) \cup (B \cap C)$  by the distributive property of intersection over union.

5)  $P[(A \cup B) \cap C] = P[(A \cap C) \cup (B \cap C)]$ , since the two events in step 4 are equal their probabilities are equal.

6)  $P[(A \cap C) \cup (B \cap C)] = P(A \cap C) + P(B \cap C) - P[(A \cap C) \cap (B \cap C)]$ .

Step 6 is an instance of theorem 3.

7) But  $[(A \cap C) \cap (B \cap C)] = (A \cap B \cap C)$  from a theorem about sets involving the associative and commutative property of intersection of sets and the fact that  $C \cap C = C$ ;

8) And therefore  $P[(A \cap C) \cap (B \cap C)] = P(A \cap B \cap C)$ , since the events in step 7 are equal and thus their probabilities are equal.

9) Now using the transitive property of equality on steps 5 and 6 and substituting the right side of 8 for the last term in 6:

$$P[(A \cup B) \cap C] = P(A \cap C) + P(B \cap C) - P(A \cap B \cap C)$$

10) Now substituting the right side of 3 in place of  $P(A \cup B)$  on the right side of 2, and substituting the right

side of 9 for  $P[(A \cup B) \cap C]$  on the right side of 2, we get:  
 $P(A \cup B \cup C) = P(A) + P(B) + P(C) - P(A \cap B) - P(A \cap C) - P(B \cap C) + P(A \cap B \cap C).$

16. 1)  $P(\overline{A \cup B}) = 1 - P(A \cup B)$  by theorem 1b.  
2) But from a set theorem,  $\overline{(A \cup B)} = \overline{(A \cap B)}$ .  
3) So substituting the right side of step 2 for  $\overline{(A \cup B)}$  in step 1 gives the result.

#### 6.6 Uniform Probability Measure. ( $2\frac{1}{2}$ - $3\frac{1}{2}$ days)

The initial examples of probability measures given before this section were non-uniform. If the students see non-uniform examples first, then the uniform cases never come as a surprise. To give the specialized case of a uniform measure first often gives students the impression that this is the only kind. It is important to emphasize in your teaching that this is a special case.

The points that should be stressed in this section are: the definition of a uniform probability measure, Theorem 4, which justifies the formula  $P(A) = \frac{n(A)}{n(S)}$  for finding the probability of an event A in a space where the probability measure is uniform, and the 4 examples each of which, although different from the others in nature, involves uniform probability measure. Some discussion of random numbers should take place and the table on page 48 may be used for a class experiment by assigning each student a different row in the table and having them find the frequency of each digit in that row. Then accumulate the frequencies obtained and use the information to calculate the

relative frequencies for each of the digits with respect to that portion of the table.

It should be stressed that the expression, "at random" as it is used here, simply means that for the experiment being considered, each outcome is equally likely.

If the students have not previously had some exposure to the counting principle, permutations and number of subsets, then it must be treated here since it is necessary information for understanding the examples and the exercises. In selecting an outcome set it is vital to know in certain cases whether to select ordered n-tuples or n-membered subsets.

### 6.7 Exercises

1. .4
2. a) .5      b) .74      c) .1
3. a) The set of all ordered triples of digits.  
b) .5      c) .1 (Don't forget that 000 is less than 100.)  
d) .1
4. a)  $1/6$       b)  $5/18$       c)  $11/36$       d)  $1/4$       e)  $8/9$
5. a)  $1/455$       b)  $1/910$       c)  $6/455$
6. The problem here is to first find the total number of 3-jump trips the rat can make starting at (0, 0). This number is 64 and can be justified quite easily by observing that there are 4 jumps that the rat can make from the point (0, 0) and from each of the points that the rat can reach at the end of 1 jump there are 4 choices and from every one of the points that the rat can reach at the end of 2 jumps there are

4 choices. Therefore by the counting principle there are  $4 \cdot 4 \cdot 4 = 64$  possible 3-jump trips that the rat can make.

Nine of these terminate at (0, 1). Thus the probability that the rat will be at (0, 1) at the end of a 3-jump trip is  $9/64$ .

The 9 possible trips which end at (0, 1) are:

1st trip		2nd trip		3rd trip	
(0,0)	to	(0,1)	to	(0,0)	to (0,1)
(0,0)	to	(0,1)	to	(0,2)	to (0,1)

and so on .....

7. The first probability ( $x=0$ ) is  $\binom{5}{0} (1/3)^0 (2/3)^5 = 32/243$ .

The next is, ( $x=1$ ),  $\binom{5}{1} (1/3)^1 (2/3)^4 = 80/243$

and so on .....

8. An estimate based on my computation is  $3/54145$ .

At any rate a more sensible answer is:

$$\frac{\binom{4}{3} \binom{4}{2}}{\binom{52}{5}}$$

9. a)  $21^3 \times 5^2$   
b) misprint  
c) 10  
d)  $21^3 \times 5^2 \times 10$

e)  $\frac{1}{21^3 \times 5^2 \times 10}$

f) part a -  $[21 \times 20 \times 19 \times 5 \times 4]$

10. For the experiment of tossing 3 dice, the nature of the outcome set is that of a set of ordered triples.

A sketch of the outcome set would be  $\{(1, 1, 1), (1, 1, 2) \dots (1, 2, 1) \dots (6, 6, 5), (6, 6, 6)\}$ .  $n(S) = 6 \cdot 6 \cdot 6 = 216$ .

a) The probability of 3 sixes here is  $\frac{1}{216}$ .

b) 3

c) The probability of 2 fives and 1 six is  $3/216 = 1/72$ .

d) The probability of 0 sixes is  $125/216$ .

11. The probability that one of the cards drawn was the 5 card is  $3/10$ .

The probability that all three of the cards were even is  $1/12$ .

The probability that all three were even or one of the cards was the 5 card is  $3/10 + 1/12 = 23/60$ .

A theorem is, if two events are disjoint, then the probability of their union is the sum of the probabilities of the two events.

12. a)  $\{3, 4, \dots, 18\}$

b) 3

c)  $\frac{3}{216}$

d)  $P(3) = \frac{1}{216}$ ;  $P(4) = \frac{3}{216}$ ;  $P(5) = \frac{6}{216}$ ;

$P(6) = \frac{10}{216}$ ;  $P(7) = \frac{15}{216}$ ;  $P(8) = \frac{21}{216}$ ;

$P(9) = \frac{25}{216}$ ;  $P(10) = \frac{27}{216}$ ;  $P(11) = \frac{27}{216}$ ;

$P(12) = \frac{25}{216}$ ;  $P(13) = \frac{21}{216}$ ;  $P(14) = \frac{15}{216}$ ;

$P(15) = \frac{10}{216}$ ;  $P(16) = \frac{6}{216}$ ;  $P(17) = \frac{3}{216}$ ;

$P(18) = \frac{1}{216}$ .



e.g.,  $P(12) =$

$$P(\{(1, 5, 6), (1, 6, 5), (5, 1, 6), (6, 1, 5), (5, 6, 1), (6, 5, 1), (2, 4, 6), (2, 6, 4), (4, 2, 6), (6, 2, 4), (4, 6, 2), (6, 4, 2), (3, 3, 6), (3, 6, 3), (6, 3, 3), (2, 5, 5), (5, 2, 5), (5, 5, 2), (3, 4, 5), (3, 5, 4), (4, 5, 3), (5, 4, 3), (4, 3, 5), (5, 3, 4), (4, 4, 4)\}) \\ = \frac{25}{216} .$$

### 6.8 Looking Back (1 day)

The important ideas to be stressed in this section are:

- 1) The stability of relative frequencies developed experimentally and illustrated graphically;
- 2) The concept of probability as a predication of relative frequency;
- 3) The choice of a probability measure may be based on the nature of experimental objects, on evidence based on experimental data, or on assumptions as long as it satisfies the properties of the definition.

### 6.9 Exercises

The purpose of exercises 1 and 2 is to give the students some practice in performing experiments, recording the results, and making a decision about the kind of probability measure that might be appropriate.

3. a) Uniform      b) non-uniform      c) non-uniform  
d) non-uniform      e) uniform      f) non-uniform  
g) uniform

4. One would predict the frequency, 34, for the outcome, tails.  
One would predict a relative frequency of  $2/3$  for tails.

6.10 Looking Ahead. (1 day)

The big idea in this section is the idea of a random variable. Random variables have been implicit in the material on probability in Course I and in the statistics in Course II. Here the term is defined and examples are given. The students should be given opportunity to provide many more examples. Since a random variable is neither random nor a variable, it is important to emphasize the fact that it is really a mapping or function. In Course IV, Chapter 6 theory and applications related to independent events are developed. Two events A and B are independent if and only if  $P(A \cap B) = P(A) \cdot P(B)$ .

6.11 Exercises

1. a) and b) The answers to these are contained in the diagram for c).

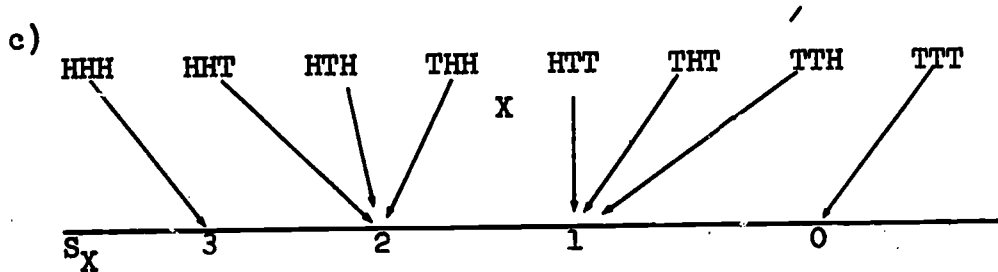

- d) and e)

$P_X$	$\frac{1}{8}$	$\frac{3}{8}$	$\frac{3}{8}$	$\frac{1}{8}$
-------	---------------	---------------	---------------	---------------

2. a) and b)

$\frac{1}{2}$	$-\frac{1}{2}$	$P(\{x\})$
.	.	
0	1	x

(If this doesn't satisfy the requirements of a probability measure check your computation again.)

3. a)  $\{(1,2), (1,3), (1,4), (1,5), (2,1), (2,3), (2,4)$   
 $(2,5), (3,1), (3,2), (3,4), (3,5), (4,1), (4,2)$   
 $(4,3), (4,5), (5,1), (5,2), (5,3), (5,4)\}$



7. a) 49

b) c) and d):

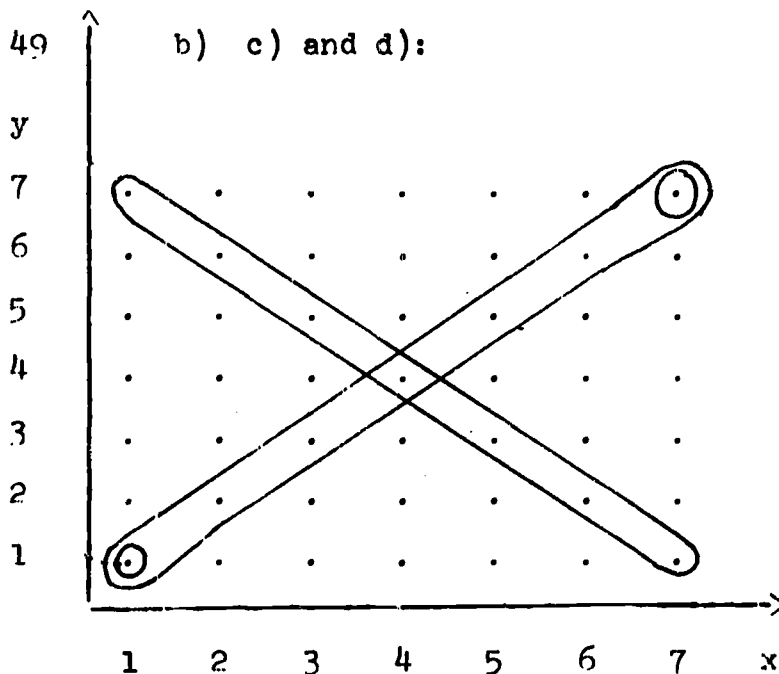

8. The project in 8 is to copy and complete the arrow diagram.  
diagram.

**REVIEW TESTS**

Test A.

Use the following information for exercises 1 to 6. There were 4 entrances to the first floor of a store called the North, South, East and West entrances respectively. Once you were inside, there were 3 choices of ways to get to the 2nd. floor; elevator, escalator or walking up stairs.

1. Tabulate the outcome set for the experiment of selecting a way to get from the street to the 2nd. floor.
2. How many ways are there to get from the street to the 2nd. floor?
3. Assuming a uniform probability measure for the outcome set in Exercise 1, what is the probability of selecting a path which includes riding to the 2nd. floor from the 1st? What is the probability of selecting an outcome by which one walks from the street to the 2nd. floor?

5. What is the probability that one uses the North or South entrance and then takes the elevator or walks to the 2nd. floor?
6. What is the probability that one takes the East entrance and rides the escalator to the 2nd. floor?

Use the following information in answering questions 7 to 10.

The guidance director in a school found, on the basis of previous records, that the relative frequency with which a senior received a grade of A in mathematics was .06; of A in English was .09; and of A in both mathematics and English was .02. These relative frequencies were then used in connection with predicting results for the following year.

7. What is the probability of getting an A in mathematics and not in English?
8. What is the probability of getting an A in English and not in mathematics?
9. What is the probability of getting an A in neither mathematics nor English?
10. Draw a Venn diagram for the events related to the guidance directors survey and label regions with the appropriate probabilities.
11. Draw a Venn diagram for the event:  
 $(A \cap B \cap C) \cup (A \cap B \cap \bar{C}).$
12. Use the operations of union, intersection and complementation to express the set relationship as indicated by the shaded region in the following Venn diagram.

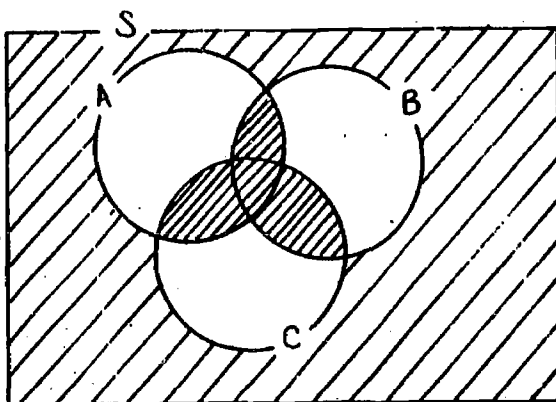

Use the following information in answering questions 13 to 18.  
 For the outcome set  $\{a_1, a_2, a_3\}$  the probability of  $\{a_1\}$  is .15; of  $\{a_2\}$  is .45; and of  $\{a_3\}$  is .40.

- |                                      |                                 |
|--------------------------------------|---------------------------------|
| 13. Compute $P(\{a_1, a_2\})$ .      | 14. Compute $P(\{a_1, a_3\})$ . |
| 15. Compute $P(\{a_1, a_2, a_3\})$ . | 16. Compute $O(\{a_1\})$ .      |
| 17. Compute $O(\{a_2\})$ .           | 18. Compute $O(\{a_3\})$ .      |

Test B.

Use the following information to answer questions 1 to 9.

.....  
 \_\_\_\_\_  
 4W   3W   2W   1W   Home   1E   2E   3E   4E

The starting point in this game is the point labeled "Home."  
 Toss a symmetric coin. If the coin lands heads, go 1 unit East.  
 If the coin lands tails, go 1 unit West. Keep repeating this  
 procedure from the last destination until you have tossed the  
 coin 4 times. What is the probability that after 4 tosses you  
 will be at:

- |          |        |        |       |
|----------|--------|--------|-------|
| 1. Home? | 2. 1E? | 3. 2E? | 4. 1W |
| 5. 2W    | 6. 3E  | 7. 4E  | 8. 3W |
|          |        |        | 9. 4W |

Questions 10 to 14 refer to selecting 3 cards at random from a standard bridge deck.

What is the probability that:

10. All 3 will be hearts?
11. All 3 will be number cards?
12. All 3 will be picture cards?
13. Two will be kings and one will be a queen?
14. All 3 will be numbered with the same number?

### Test C.

Questions 1 to 6 will refer to selecting two-digit random numbers from a table of random numbers.

What is the probability that the number will be:

1. Less than 10 or greater than 89?
2. Greater than 15 and less than 26?
3. Less than or equal to 3?
4. Not less than or equal to 3?
5. Less than 12 and greater than 23?
6. Less than 5 or less than 3?

Use the following information in answering questions 7 to 13. Two symmetric cubes, one blue and one red, are each labeled with numeral 3 on two sides and the numeral 5 on the other 4 sides. The experiment is to roll the two cubes and record the ordered pair of numbers indicated on the upper faces. Let the number shown by the blue cube be the first component and the number on the red cube be the second component.

7. Tabulate the outcome set.
8. Assuming that each face of such a cube is equally likely, make a table showing the probability of each outcome.
9. Let the random variable  $X$  assign the sum of the components of an outcome to that outcome. Make a table showing the assignments made by  $X$ .
10. Make a table showing the assignment of probabilities to the images under the random variable  $X$ .

#### B I B L I O G R A P H Y

Fehr, Howard F. et al., An Introduction to Sets, Probability and Hypothesis Testing, D. C. Heath.

Goldberg, Samuel, Probability, An Introduction, Prentice-Hall.

Mosteller, F., Rourke, R. E. K., and Thomas, G. B., Probability with Statistical Applications, Addison-Wesley.

Feller, W., An Introduction to Probability Theory and its Applications, John Wiley.

Mosteller, F., Fifty Challenging Problems in Probability, Addison-Wesley.

Introduction to Probability, Parts 1 and 2, School Mathematics Study Group.

Owen, G., Finite Mathematics, W.B. Saunders Company, 1970.

Huff, D. and Geis, I., How to Take a Chance, W.W. Norton Inc.



## Chapter 7

### POLYNOMIAL AND RATIONAL FUNCTIONS

Time Estimate: 17 - 21 days

#### Introduction

The overall concern of this chapter is that of introducing and developing basic algebraic skills within the framework of a structured course. Specifically, the objectives of this chapter are:

1. to realize the nature of a polynomial function;
2. to introduce and develop skill in operations with polynomial functions:
  - (a) addition, multiplication, and division,
  - (b) reinforcement of the Binomial Theorems and the division Algorithm;
3. to factor functions of second and third degree polynomials;
4. to study and graph the quadratic function, using applications of transformation geometry;
5. to extend polynomials to rational functions:
  - (a) operations with algebraic fractions,
  - (b) graphing of rational functions,
  - (c) understanding limitations on the domain of Reals;
6. to investigate a commutative ring with unity.

7.1 Polynomial Functions (Time for 7.1 and 7.2 = 1 day)

Students should come to this chapter with an understanding of the identity function  $j$  on the set of real numbers, and of constant functions  $c_a$ ,  $a \in R$ . The principal concern of this section is to develop an understanding of the definition of a polynomial function over the real numbers. Students should be made aware that a polynomial function may be generated by addition only, by multiplication only, or by a combination of both addition and multiplication. However, no other operations may be used. One productive activity might be that of presenting the class with the identity function and several constant functions, then having them compile a list of polynomial functions they can generate. One student might put his list on the board, with other students called upon to explain how each was generated.

One point which is not mentioned in the text, but which might arise is this:  $\frac{x}{3}$ , when considered as the quotient of  $j_R$  by  $c_3$  is technically not a polynomial function. However,  $\frac{x}{3} = \frac{1}{3}x$ , which is the product of  $c_{\frac{1}{3}}$  and  $j_R$ . Since this equivalent form is a result of the multiplication of functions, then  $\frac{x}{3}$  may be considered as a polynomial.

As noted in the text, a polynomial is associated with every polynomial function, and much of our study of these functions will be done in terms of the associated polynomials. Actually, "polynomial expression" might be a better name to

use than "polynomial". But until such time as students study abstract polynomial theory, there seems to be little chance of confusion in using the shorter (and common) term "polynomial" in the context of this chapter.

Encourage students to think independently about the two questions posed in the first paragraph of the section, even though they have no formal machinery with which to compute answers. (Solutions: 2 seconds; 16 feet).

## 7.2 Exercises

- |   |                                    |
|---|------------------------------------|
| (a) 10  | (b) 7                              |
| (c) $x$                                       | (d) $1 + x$                        |
| (e) $-4x^3 + \sqrt{2x} - 10$                  | (f) $x^8 + x$                      |
| (g) $(x + x + x + x + x) \cdot x$ , or $5x^2$ | (h) $7x^2 - x + 0$ , or $7x^2 - x$ |
| (i) $-x^3 + 12x^2 + 4x + 9$                   | (j) $0x$ , or $0$                  |
| (k) $x^2 + 1$                                 | (l) $8x^4 - 3x^2 + 7$              |
- |                            |                        |
|----------------------------|------------------------|
| (a) $x^5 + 3x + 4$         | (b) $-7x^5 - x^2 + 4x$ |
| (c) $x^9 + x^8 + x^3$      | (d) $-3x^2 - 2x + 7$   |
| (e) $8x^3 - 7x^2 + 3x + 4$ |                        |
- |  |
|--|
| (a) $[(c_2 \cdot j \cdot j \cdot j \cdot j \cdot j \cdot j) + (c_3 \cdot j \cdot j \cdot j \cdot j \cdot j) + c_6]$  |
| (b) Not a polynomial; requires <u>division</u> by $j$ .  |
| (c) $[(c_1 \cdot j) + c_1]$  |
| (d) Technically not a polynomial, since it requires division by $c_3$ . However, it is equivalent to the polynomial in part (c), and so may be considered as a polynomial. (See Teacher's Commentary, Section 7.1) |

- (e) Not a polynomial, requiring division by  $j_R$ .
- (f) Technically not a polynomial, since it requires division by  $c_2$ . However, equivalent to polynomial  $\frac{1}{2}x$ .
- (g)  $(c_{-1} \cdot j \cdot j) + (c_{-5} \cdot j) + (c_{-10})$ .
4. (a)  $x + 2$   
 (b)  $2 - x$   
 (c)  $2x$   
 (d) not a polynomial  
 (e)  $\frac{1}{2}x$
5.  $[(C_{a_n} \cdot \underbrace{j \cdot j \cdots j}_{n \text{ factors}}) + (C_{a_{n-1}} \cdot \underbrace{j \cdot j \cdots j}_{n-1 \text{ factors}}) + \dots + (C_{a_1} \cdot j) + C_{a_0}]$
6. Answers vary.
7. (a)  $-14\frac{1}{3}$  (b)  $-8$   
 (c)  $19$  (d)  $-25\frac{1}{3}$   
 (e)  $128\frac{2}{3}$
8. (a)  $C_0$  is of form  $C_a$ ,  $a \in R$ . The range is  $\{0\}$ .  
 (b)  $C_1$  is of form  $C_a$ ,  $a \in R$ . The range is  $\{1\}$ .  
 (c)  $j$   
 (d)  $C_0$   
 (e)  $j$
9. (a) Yes, by definition  
 Yes,  $2 \cdot x = x + x \quad \forall x$   
 (b) True;  $3 \cdot x = x + x + x \quad \forall x$   
 (c)  $[C_m \cdot j]$
10. (a)  $C_0$  (b)  $C_8$   
 (c)  $C_2 \cdot j \cdot j$  (d)  $C_0$   
 (e)  $C_2 \cdot j \cdot j$

### 7.3 Degree of a Polynomial (Time for 7.3 and 7.4 = 1 day)

The object of this section is primarily to introduce vocabulary, although the concept of degree of a polynomial function is not an unimportant one. Notice in this section, as indeed throughout the chapter, that there is a kind of dual development. If one defines degree of a polynomial function, he has automatically defined degree of a polynomial (expression). Thus, the degree of the function  $x \longrightarrow x^3$  is three, and the degree of the polynomial " $x^3$ " is three.

The altogether simple use of the phrases "coefficient," "constant term," and "leading coefficient" is probably best established by numerous examples.

Point out the importance that  $a_n \neq 0$  in the definition of degree. This importance is brought out in  $f: x \longrightarrow 0x^3 + 5x - 2$ . Here, it is quite all right (and in fact more commensurate with abstract polynomial theory) to consider the coefficient of  $x^3$  to be 0. However the degree is the greatest exponent associated with a nonzero coefficient.

Stress the fact that the zero polynomial function ( $c_0: x \longrightarrow 0$ ) has no degree; therefore the polynomial "0" has no degree. However, for  $a \neq 0$ , any polynomial function  $c_a$  has degree zero.

7.4 Exercises

1. (a) 3 (b) 5 (c) 3 (d) 0 (e) no degree  
 2. (a) 2 (b) 1 (c) 0 (d) no degree  
 (e) 7 (f) 2 (g) 4 (h) 10 (i) 1 (j) 2  
 3. (a)  $\sqrt{7}$  (b) -5 (c)  $-\frac{2}{3}$  (d) third (e) 3 (f) -5  
 4. (a) 6 (b) -8 (c) third (d) second (e) 2 (f) -8  
 5. (a) -7 (b) -10 (c) 0 (d) 0 (e) -4  
 6. (a) -3 (b) -3 (c) 5 (d) 0 (e) 0  
 7. (a) 0 (b) 1 (c) 1 (d) 0 (e) 0  
 (f) no degree (g) 1

8.

	Polynomial Over Integers	Polynomial Over Rationals	Real Polynomials
(a)	<u>          x          </u>	<u>          x          </u>	<u>          x          </u>
(b)	<u>                          </u>	<u>                          </u>	<u>                          </u>
(c)	<u>          x          </u>	<u>          x          </u>	<u>          x          </u>
(d)	<u>          x          </u>	<u>          x          </u>	<u>          x          </u>
(e)	<u>          x          </u>	<u>          x          </u>	<u>          x          </u>
(f)	<u>          x          </u>	<u>          x          </u>	<u>          x          </u>
(g)	<u>                          </u>	<u>          x          </u>	<u>          x          </u>
(h)	<u>                          </u>	<u>                          </u>	<u>                          </u>
(i)	<u>          x          </u>	<u>          x          </u>	<u>          x          </u>

7.5 Addition of Polynomials (P, +). (Time for 7.5 and 7.6 = 1 to  $1\frac{1}{2}$  days)

The purposes of this section are twofold:

1. to develop an understanding that  $(P, +)$  is an operational system. Here  $P$  is the set of polynomial functions and  $+$  is function addition.
2. to develop skill in the addition of polynomials.

The purpose of Example 1 -- and of several of the exercises in Section 7.6 -- is to remind students that, for instance, " $4x^2 - 3x + 6$ " is a legitimate substitution for " $(9x^2 + 3x - 2) + (-5x^2 - 6x + 8)$ " since for every  $x \in R$ ,  $(9x^2 + 3x - 2) + (-5x^2 - 6x + 8) = 4x^2 - 3x + 6$ . Lest some students miss the importance of this, it is important to use some numerical instances. (See Section 7.6, exercise 1)

Emphasis is placed on the fact that  $(P, +)$  is a commutative group by developing some of the properties within the exposition and leaving others to be done as exercises. It is therefore important that exercises 19, 20, 21, 22, 23 and 29 (in Section 7.6) be completed.

The theorem (it is not stated as a theorem in the text) concerning the degree of a sum of two polynomial functions should follow easily from consideration of specific illustrations. Note that the general theorem does not apply if either of the functions  $p, q$  is  $c_0$ . "Max" is an operation on the real numbers; so both  $\deg(p)$  and  $\deg(q)$  must be numbers in order

for the theorem to have meaning. Since  $\deg(c_0)$  is not a number, the exclusion is necessary.

## 7.6 Exercises

NOTE: Teacher discretion is advised in assigning only a limited number of problems. Imperative in the assignment should be 1, 19 to 23, 29, 30, 31, and 38 c,d.

1. (a)  $3x^3 - 4x^2 - 4x$   
(b)  $0$ ;  $24 - 16 - 8 = 0$ ; check:  $-10 + 10 = 0$   
(c)  $0$ ;  $0 - 0 - 0 = 0$ ; check:  $4 + (-4) = 0$   
(d)  $-455$ ;  $-375 - 100 + 20 = -455$ ; check:  $-311 + (-144) = -455$
2.  $4x^3 - 24x - 17$
3.  $-13x^3 - 12x^2 - 5x + 17$
4.  $-30x$
5.  $\frac{5}{4}x^3 - \frac{2}{3}x^2 + \frac{5}{3}x$
6. 0 (zero polynomial)
7.  $2\sqrt{2}x^2 + (\frac{3}{5} - \sqrt{5})x + (-\sqrt{7} + \frac{1}{2})$
8.  $2x^{10}$
9.  $x^4 + 1.2x^3 + x^2 - .4x + .7$
10.  $\frac{26}{5}x^2 + x + \frac{4}{5}$
11.  $-7x^4 + \frac{1}{2}x^3 + \frac{5}{6}x^2 - 7x + 6$
12.  $(a_2 + b_2)x^2 + (a_1 + b_1)x + (a_0 + b_0)$



13.  $5x^3 + x + 11$
14.  $-11x^3 - 4x^2 + 14 + 4x$
15.  $20x^4 + 3x^3 - x^2 + 4x - 17$
16. 0 (zero polynomial)
17.  $42x^3 - 16x^2 + 6x + 25$
18.  $\frac{1}{2}x^4 + x^3 - x^2 + \frac{3}{4}x + \frac{5}{2}$
19. (a)  $-20x^2 + 9x - 15$  (b)  $14x^{10} - 7x^8 + 6x^6 + (16 + \sqrt{6})$   
(c)  $7x^2 - 3x + 8$  (d)  $7x^2 - 3x + 8$   
(e)  $10x^3 + 8x^2 - 7x - 19$  (f)  $41x^3 + 19x^2 - 22$
20. (a) 0 (zero polynomial) (b) 0 (zero polynomial)  
(c) 0 (zero polynomial) (d) 0 (zero polynomial)
21. (a) 0 (zero polynomial) (b)  $g: x \longrightarrow -3x^2 + 4x - 6$
22. (a)  $-f: x \longrightarrow -\frac{1}{2}x^3 + 3x - 7$  (b)  $C_0$
23. (a)  $-g: x \longrightarrow -3x^3 - 14x^2 + 35x + 19$  (b)  $C_0$
24.  $-3x^3 - 14x^2 + 35x + 19$
25.  $x^2 + 7x - 5$
26.  $-7x^4 + 5x^3 - 8x^2 + 14x + 8$
27.  $-17x^3 + 8x - 9$
28.  $-4x^2 + 9x - 10$
29. (a) associativity, commutativity, identity element, inverse for each element  
(b) yes
30. (a) yes (b) yes
31.  $5x^2 - 12x + 39$
32.  $6x^3 - 14x^2 + 13x + 11$
33.  $-2.5x^4 - 5.4x^2 - 2.8$
34.  $\frac{1}{2}x^2 + \frac{7}{4}x - \frac{1}{6}$

35.  $2\sqrt{2}x + 9$
36.  $-17x^4 + 8x^3 - 19x^2 - 12x + 10$
37.  $5x^3 - 3x^2 + 20x - 18$
38. (a)  $4x^3 - 2x^2 - 4x - 1$       (b)  $4x^3 - 2x^2 - 4x - 1$   
(c)  $6x^3 + 2x^2 - 10x + 11$       (d)  $4x^3 + 4x^2 - 12x + 13$   
(e)  $4x^3 - 2x^2 - 4x - 1$       (f)  $6x^3 + 2x^2 - 10x + 11$
39. (a)  $\deg(f+g) = 5$       (b)  $\deg(f+g) = 3$   
(c)  $\deg(f+g) = 6$
40.  $(P_Q, +)$  is a subgroup of  $(P, +)$ .  
 $(P_Z, +)$  is a subgroup of  $(P_Q, +)$ .

### 7.7 Multiplication of Polynomial Functions $(P, +, \cdot)$

(Time for 7.7, 7.8 = 2 to  $2\frac{1}{2}$  days)

In this section the emphasis is on the operational system  $(P, \cdot)$  and on developing skill in multiplication of polynomials. An interesting aspect is that  $(P, \cdot)$  forms an operational system while it does not form a group. While stressing that the product of two polynomials is always a single polynomial, it can be said that the group structure fails only because the inverse property fails.

In studying two specific cases to demonstrate closure under multiplication, students must accept the theorem that

$$\deg(p \cdot q) = \deg(p) + \deg(q); \quad p \neq c_0; \quad q \neq c_0.$$

Incidentally the proof that  $(P, \cdot)$  is not a group, involving proof that at least one polynomial  $x^2$ , does not have an inverse, might be used to remind students that one counter-example is enough to prove that a general statement does not hold.

The question in the text, "Can you identify some polynomial functions that do have inverses in  $(P, \cdot)$ ?" is easily answerable. It is precisely the subset of polynomial functions of form  $c_a$ ,  $a \in R$  and  $a \neq 0$ . (Example: inverse of  $x \rightarrow 4$  is  $x \rightarrow \frac{1}{4} \cdot c_4 \cdot c_{\frac{1}{4}} = c_1$ ). No other polynomial has a polynomial multiplicative inverse.

TO THE TEACHER:

In summarizing the properties of  $(P, +, \cdot)$ , the text notes that these are the defining properties of a commutative ring with unity. (This might be omitted, with omission also of Exercise 58 and 59 in Section 7.8).

PROPERTIES	RING	COMMUTATIVE RING	RING WITH UNITY	COMMUTATIVE RING WITH UNITY
$(S, +)$ operational system	YES	YES	YES	YES
$(S, +)$ associativity	YES	YES	YES	YES
$(S, +)$ identity	YES	YES	YES	YES
$(S, +)$ inverses	YES	YES	YES	YES
$(S, +)$ commutativity	YES	YES	YES	YES
$(S \setminus \{0\}, \cdot)$ operational system	YES	YES	YES	YES
$(S \setminus \{0\}, \cdot)$ associativity	YES	YES	YES	YES
$(S \setminus \{0\}, \cdot)$ identity			YES	YES
$(S \setminus \{0\}, \cdot)$ inverses				
$(S \setminus \{0\}, \cdot)$ commutativity		YES		YES
$(S, +, \cdot)$ distributives over +	YES	YES	YES	YES

## 7.8 Exercises

NOTE: Teacher discretion should again be employed in assigning a limited number of these exercises. Imperative to any assignment should be 1 to 5, 20, 21, 26, 29, 49, 54, and 57.

1. (a)  $x^3 + x^2 - 2x - 8$  (b)  $0 = 0.14$   
(c)  $-20 = (-5)(4)$  (d)  $-8\frac{5}{8} = (-\frac{3}{2})(5\frac{3}{4})$
2.  $x^2 + 7x + 10$
3.  $x^2 - 3x + 10$
4.  $x^2 + 3x - 10$
5.  $x^2 - 7x + 10$
6.  $2x^2 + 17x + 21$
7.  $10x^2 + 13x - 30$
8.  $2x^3 - 15x^2 - 7x - 8$
9.  $x^4 + 4x^3 - 8x^2 + 11x + 40$
10.  $12x^5 + 28x^4 + 32x^3 - 21x^2 - 49x - 56$
11.  $\frac{1}{3}x^2 + \frac{1}{15}x - \frac{1}{20}$
12.  $\frac{21}{64}x^2 - \frac{1}{32}x - \frac{1}{8}$
13.  $.06x^2 + .01x - .35$
14.  $2x^{10} - 6x^9 + 10x^8 + 5x^4 - 15x^3 + 25$
15.  $x^{18} - 2x^8 + 8x^7 - 16$
16.  $x^2 + 14x + 49$

17.  $x^2 - 16x + 64$

18.  $9x^2 - 60x + 100$

19.  $4x^2 + 20x + 25$

20.  $y^2 + 8y + 16$

21.  $a^2 - 18a + 81$

22.  $t^2 + t + \frac{1}{4}$

23.  $x^2 + 2\sqrt{2}x + 2$

24.  $t^2 + 32t + 256$

25.  $x^2 + 2bx + b^2$

26.  $a^2x^2 + 2abx + b^2$

27.  $x^4 + 4x^3 + 6x^2 + 4x + 1$

28.  $a^2x^4 + 2abx^3 + (2ac + b^2)x^2 + 2bcx + c^2$

29.  $y^2 - 16$

30.  $x^2 - 36$

31.  $t^2 - \frac{1}{9}$

32.  $a^2 - .36$

33.  $4x^2 - 49$

34.  $9x^2 - 16$

35.  $36a^2 - 49$

36.  $\frac{1}{4}x^2 - \frac{4}{25}$

37.  $x^2 - 5$

38.  $9t^2 - 6$

39.  $x^2 - b^2$

40.  $a^2x^2 - b^2$

41.  $x^3 + 8$

42.  $a^3 - 125$

43.  $z^4 - 5z^3 + 14z^2 + 8z - 96$

44.  $8n^4 + 56n^3 + n + 7$

45.  $a^3 + b^3$

46.  $a^3 - b^3$

47.  $30x^9 - 2x^8 + 29x^7 + 51x^6 - 57x^5 - 6x^4 + 107x^3 + 62x^2 - 59x - 40$

48.  $-5x^{15} + 5x^{13} + 3x^{12} + 42x^{10} - 2x^9 - 25x^7 - 12x^5 + 18x^4 + 12x^3 + 108$

49.  $-3x^5 + 2x - 7$

50.  $-3x^5 + 2x + 7$

51.  $x^2 - \sqrt{5}$

52.  $x^2 - \sqrt{5}$

53.  $-6x^2 + 5x + 56$

54. (a)  $-x^5 - 5x^4 - 6x^3 + 3x^2 + 16x + 14$

(b)  $-x^5 - 5x^4 - 5x^3 + 4x^2 + x - 6$

(c) 0

(d)  $x^2 + 5x + 6$

(e)  $x^5 + 4x^4 + 10x^3 - 3x^2 - 12x - 30$

(f)  $-x^2 - 5x - 6$

(g)  $-x^2 - 5x - 6$

(h)  $x^2 + 5x + 7$

(i)  $x^2 + 5x + 6$

(j)  $-x^6 - x^5 + 14x^4 + 27x^3 + 3x^2 - 42x - 72$

(k)  $x^6 - 6x^3 + 9$

(l)  $x^6 - x^4 - 16x^3 - 37x^2 - 60x - 27$

(m)  $x^3 - 3$

(n)  $x^3 - 3$

55. yes

yes

57. (a)  $x^8 + 3x^4 + 1 + 3x^2$   
(b)  $x^2 + 1$   
(c)  $2x^5 + x$   
(d)  $4x^{10} + 4x^8 + x^2 + 1$   
(e)  $2(x^2 + 1)^5 + (x^2 + 1)$ ; or  $2x^{10} + 10x^8 + 20x^6 + 20x^4 + 11x^2 + 3$   
(f) yes  
(g) j  
(h)  $m \cdot n$  or  $n \cdot m$
58. All except (a) and (g)
59. In (a),  $(W, +, \cdot)$  has no additive inverses. (except 0)  
In (g),  $(2 \times 2 \text{ matrices}, +, \cdot)$  is not commutative under multiplication,

7.9 Division of Polynomial Functions (Time for 7.9, 7.10 = 2 to 3 days)

$(P, \cdot)$  is not a group since it lacks inverses. Students should realize that they cannot readily change  $a \div b$  to the form  $a \cdot b^{-1}$ . It is necessary here to view the division of polynomials from the standpoint of the division algorithm:

"given positive integers  $a$  and  $b$ ,  $b \neq 0$ , there exist unique whole numbers  $q$  and  $r$  such that  $a = b \cdot q + r$  where  $0 \leq r < b$ ."

Simple arithmetical problems using the division algorithm should be done in class by the teacher, both for review and as an introduction to the more complicated polynomials.

The development of this algorithm is done by a series of examples in the text but certainly more are needed for

meaningful student comprehension. Emphasis for  $(f \div p)$  is placed

on the identity

$$f = [(q \cdot p) + r]$$

where  $q$  and  $r$  can be thought of as quotient and remainder.

This eventually takes on function notation to allow for polynomial functions:

$$f(x) = [q(x)p(x)] + r(x)$$

To the teacher:

While the proof (because of length and difficulty) is omitted from the text, it can be proved that, given two polynomial functions  $p \neq c_0$  and  $f$ , there exists unique polynomial functions  $q$  and  $r$ ,  $\deg(r) < \deg(p)$ , such that  $f = [(q \cdot p) + r]$ . The proof is outlined below.

Proof of existence:

$$(1) \text{ Let } f(x) = a_n x^n + a_{n-1} x^{n-1} + \dots + a_1 x + a_0 \quad (a_n \neq 0)$$
$$p(x) = b_m x^m + b_{m-1} x^{m-1} + \dots + b_1 x + b_0 \quad (b_m \neq 0)$$
$$n = \deg(f); \quad m = \deg(p)$$

(2) If  $n < m$ , then  $q$  must be  $c_0$ , and  $r = f$ .

(3) If  $n \geq m$ , consider the general case:

$$\frac{f(x)}{p(x)} = q(x) + \frac{r(x)}{p(x)}$$

$$\frac{f(x)}{p(x)} = \frac{a_n x^{n-m}}{b_m} + \frac{r(x)}{p(x)}$$

$$f(x) = \frac{a_n x^{n-m}}{b_m} \cdot p(x) + r(x)$$

$$f(x) - \frac{a_n x^{n-m}}{b_m} \cdot p(x) = r(x)$$

Here,  $r(x) = c_0$  or  $\deg(r) < n$ .



$$(4) \text{ If } r(x) = c_0, \text{ then } f(x) = \frac{a_n x^{n-m}}{b_m} \cdot p(x).$$

$$(5) \text{ If } \deg(r) < n, \text{ then } f(x) = \frac{a_n x^{n-m}}{b_m} \cdot p(x) + r(x)$$

**Proof of Uniqueness:**

- (1) Assume there are two pairs of polynomials  $\underline{q}$  and  $\underline{r}$  satisfying the required conditions.

$$f = qp + r$$

$$f = q'p + r'$$

$$(2) \quad qp + r = q'p + r'$$

$$(3) \quad qp - q'p = r' - r$$

$$(4) \quad (q - q')p = (r' - r)$$

$$(5) \text{ If } (q - q') \neq c_0, \text{ then } \deg(p) \leq \deg(r' - r)$$

$$(6) \text{ But } \deg(r) < \deg(p)$$

$$\deg(r') < \deg(p)$$

$$\text{Thus } \deg(r' - r) < \deg(p)$$

$$\text{or } \deg(p) > \deg(r' - r).$$

- (7) This contradicts the last statement, thus proving uniqueness.

The last part of this section deals with the divisibility of  $x^n - r^n$  by  $x - r$ , where both are real polynomials. This is of some interest in its own right of course, but its use in this chapter is primarily in proving the Factor Theorem (Section 7.13). Thus, if one plans to omit the Factor Theorem, part of the present section might also be omitted. If it is included, be sure students understand that divisibility by  $x + r$  is included since  $x + r = x - (-r)$  is of the desired form.

7.10 Exercises

Note: The teacher should limit the number of exercises assigned to students to comply with the ability of the individual student and/or class.

1.  $q: x \rightarrow x + 10$   
 $r: x \rightarrow 35$   
 $\deg(p) = 1; \deg(r) = 0$
2.  $q: x \rightarrow 3x^2 - 7x + 4$   
 $r: x \rightarrow 27x - 27$   
 $\deg(p) = 2; \deg(r) = 1$
3.  $q: x \rightarrow x^3$   
 $r: x \rightarrow 12$
4.  $q(x) = x^2; r(x) = 0$
5.  $q(x) = 0; r(x) = x$
6.  $q(x) = x + 2; r(x) = -1$
7.  $q(x) = x^2 + 2x + 4; r(x) = 0$
8.  $q(x) = 0; r(x) = x - 2$
9.  $q(x) = \frac{1}{2}x^8 - \frac{7}{2}x^6 + 7x^4 - \frac{5}{2}x^2 + 4x^2 - \frac{3}{2}x + \frac{5}{2}; r(x) = 0$
10.  $q(x) = x + 2; r(x) = -4$
11.  $q(x) = x - 3; r(x) = 0$
12.  $q(x) = 1; r(x) = 0$

13.  $q(x) = 2x + \frac{1}{2}$ ;  $r(x) = -\frac{9}{2}$

14.  $q(x) = 2x^2 + 3x - \frac{2}{3}$ ;  $r(x) = \frac{8}{3}$

15.  $q(x) = 5x - 2$ ;  $r(x) = -10x$

16.  $q(x) = x^5 + x^3 - 3x^2 + 7x - 1$ ;  $r(x) = -4$

17.  $q(x) = 2x + 3$ ;  $r(x) = 0$

18.  $q(x) = 2x + 2$ ;  $r(x) = 3$

19.  $q(x) = \frac{1}{2}x - 2$ ;  $r(x) = 0$

20.  $q(x) = x^2 - 3x + 9$ ;  $r(x) = 0$

21. (a)  $q: x \longrightarrow x - 5$ ;  $r: x \longrightarrow -7$

(b)  $-7 = (0)(3) + (-7)$

(c)  $21 = (-7)(-4) + (-7)$

(d)  $-7 = (-3)(0) + (-7)$

22. (a)  $q: x \longrightarrow 2x^2 - 15x + 67$ ;  $r: x \longrightarrow -321$

(b)  $3 = (54)(6) + (-321)$

(c)  $14 = (67)(5) + (-321)$

(d)  $-321 = -321$

23. In the first case,  $\deg(r) \neq \deg(p)$

24. (a) T (b) T (c) F (d) T (e) F (f) T (g) F

(h) T (i) T (j) T (k) T (l) T (m) T (n) F

(o) T (p) F

25. (a) T (b) T (c) F (d) F (e) T

26. (a) T (b) T (c) F (d) F (e) T

27.  $q(x) = x^5 + x^4 r + x^3 r^2 + x^2 r^3 + x r^4 + r^5$

28.  $q(x) = x^5 + x^5 r + x^4 r^2 + x^3 r^3 + x^2 r^4 + x r^5 + r^6$

29. (a)  $q(x) = x^2 + 2x + 4$

(b)  $x^2 - 2x + 4$

(c)  $q(x) = x^2$

30.  $q(x) = x^9 + x^8r + x^7r^2 + x^6r^3 + x^5r^4 + x^4r^5 + x^3r^6 + x^2r^7 + xr^8 + r^9$

### 7.11 Polynomial Factors and the Factor Theorem

(Time estimate for chapter 7.11, 7.12 = 2 to  $2\frac{1}{2}$  days.)

Whereas students previously factored polynomials with leading coefficients of "1" (see Course II, Chapter 4), this section is a natural extension to polynomials with various leading coefficients.

The method used here is a rather general one for trinomial quadratics, being based on distributivity. The student should see that it applies equally well if the leading coefficient is 1, as in earlier examples he has met. Thus,

$$x^2 + 2x - 15 = x^2 + (R + S)x - 15.$$

$$R + S = 2, \text{ and } RS = -15.$$

$$\text{So } R = 5, S = -3$$

$$\begin{aligned}x^2 + 2x - 15 &= x^2 + (5 + -3)x - 15 \\ &= x^2 + 5x - 3x - 15 \\ &= x(x + 5) - 3(x + 5) \\ &= (x - 3)(x + 5).\end{aligned}$$

One must be careful about the use of the words "factor" and "prime". The number 5, for instance, is prime over the set of whole numbers, since in that set it has no factors other than itself and 1. Over the set of rational numbers, however,

it is not prime; among others, it has the factors  $\frac{1}{2}$  and 10. Similarly, 5 is not prime over the set of real numbers. Thus, the words "prime" and "factor" are relative to the domain under discussion. In number theory, it is usually the whole numbers (or at most the integers) which constitute the domain, and thus 5 is classified as prime.

A similar situation exists when one considers factoring polynomials, specifically in this case trinomials of degree two. Here the domain must be specified for the allowable coefficients. Consider, for instance, " $x^2 + 4$ ". We are used to calling it prime, as indeed it is if the domain is the set of integers, the only factorization then being  $1(x^2 + 4)$  or  $(-1)(-x^2 - 4)$ . However, if one were to allow rational coefficients, the factorization  $\frac{1}{2}(2x^2 + 8)$ , among others, would be possible; clearly it is the product of two polynomials, neither of which is a unit. As one other example,  $x^2 - 2$  is not prime if one chooses  $\mathbb{R}$  as domain, for the factorization  $(x + \sqrt{2})(x - \sqrt{2})$  is then available.

The truth of the matter is that if the complex numbers are chosen as domain, any quadratic  $ax^2 + bx + c$  ( $a \neq 0$ ) has factors:

$$\left(x - \frac{-b - \sqrt{b^2 - 4ac}}{2a}\right)\left(x - \frac{-b + \sqrt{b^2 - 4ac}}{2a}\right)$$

For these reasons, the student is reminded that we are looking for factors of a particular kind, namely  $(ax + b)(cx + d)$ , where the coefficients are integers (we are "factoring over the integers").

The Factor Theorem has many uses in mathematics (see for instance Example 5, in which the graph of a function is sketched, using zeroes of the function.) Point out the assumption here that the graph of a polynomial is a "smooth curve". However, it might be omitted at this time if the chapter seems to be consuming too much time. In that case, omit also Exercises 21, 22, 23, 24, and 25 of Section 7.14.

#### 7.12 Exercises

1.  $f: x \longrightarrow x + 7$        $g: x \longrightarrow x - 4$
2.  $f: x \longrightarrow 3x - 5$        $g: x \longrightarrow x + 4$
3.  $(x - 8)(x - 3)$
4.  $(x + 11)(x + 3)$
5.  $(x - 8)(x + 1)$
6.  $(x + 7)(x - 5)$
7.  $(2x + 3)(x - 7)$
8.  $(4x - 3)(x + 5)$
9.  $(5x + 2)(x + 2)$
10.  $(7x - 2)(x + 3)$
11.  $(5x + 1)(3x - 2)$
12. prime over the integers
13.  $(6x + 5)(x - 10)$
14.  $(2x + 3)(3x - 8)$
15.  $(9x - 2)(x + 3)$

16. (a)  $(x + 2)(x - 2)$   
(b)  $(x + 4)(x - 4)$   
(c)  $(n + 10)(n - 10)$   
(d)  $(2x + 3)(2x - 3)$   
(e)  $(5y + 7)(5y - 7)$   
(f)  $(x + b)(x - b)$   
(g)  $(ax + b)(ax - b)$

17. NOTE: Students may, by this time, recognize these as  $(a + b)^2$  and  $(a - b)^2$ .

- (a)  $(x + 3)(x + 3)$   
(b)  $(a + 5)(a + 5)$   
(c)  $(x - 4)(x - 4)$   
(d)  $(x - 12)(x - 12)$   
(e)  $(x - a)(x - a)$   
(f)  $(x + a)(x + a)$

18. (a)  $+49$   
(b)  $+81$   
(c)  $+\frac{25}{4}$   
(d)  $+\frac{1}{4}$   
(e)  $+\frac{b^2}{4}$   
(f)  $+\frac{b^2}{4a^2}$

19. b, c, and d are prime

20. a and d are prime

21. (a) 0 (b) yes (c)  $x^2 + x + 2$

22. (a) -28 (b) no (c) 0 (d) yes

(e)  $-x^2 + x - 5$

23. (a) 0, (b) yes (c)  $x^2 + \frac{1}{2}x + \frac{1}{4}$
24. (a)  $p(5) = 0$  (b)  $(x - 5)(x - 3)(x + 1)$   
 (c)

x	y
-1	0
0	15
1	16
2	9
3	0
4	-5
5	0

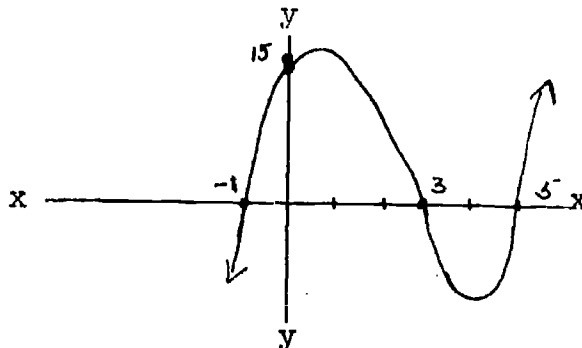

25. (a)

x	y
-1	0
0	-15
1	-16
2	-9
3	0
4	5
5	0

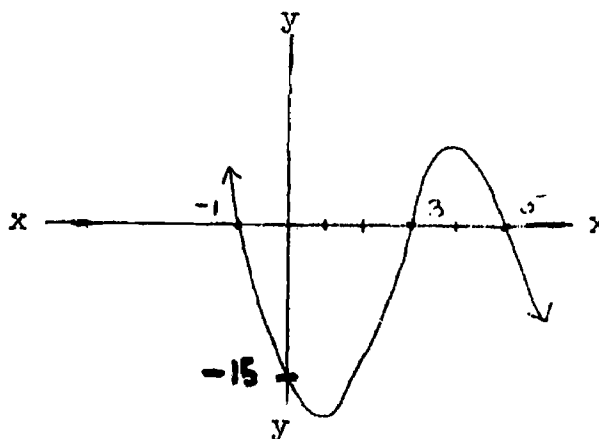

- (b)  $(5 - x)(x - 3)(x + 1)$

7.13 Quadratic Functions and Equations (Time for 7.13, 714 = 2 to  $2\frac{1}{2}$  days.)

The student has had extensive work with the graph of  $x^2$ , and in Chapter 4, of  $ax^2$  and  $ax^2 + b$ . In this section we work to the more general form

$$a(x - h)^2 + k$$



Students should see that this may be considered as the graph of a condition  $C'(x',y')$ , obtained from the graph of  $ax^2$  (condition  $C(x,y)$ ) by the translation  $(x + h, y + k)$ .

The various possible intersections of the graph of a quadratic function with the X-axis should lead naturally to a discussion of the number of zeroes--none, one, or two--and hence to the possible number of real solutions of a quadratic equation.

The technique of completing the square is not an easy one for students, and it is quite likely that Example 3, and similar examples, will have to be carefully explained in class. The teacher should refer back to problem 18 of Section 7.12 (completing the square) and could present quadratics with leading coefficients = 1 before doing Example 3.

NOTE: Special attention should be paid to problem 7(i) in Section 7.14, since it develops the general solution for a quadratic equation. A good deal of class time should be devoted to its development and meaning. Various other approaches can be taken here:

Approach 1:  $ax^2 + bx + c = 0, \quad a \neq 0$

$$a\left(x^2 + \frac{b}{a}x\right) + c = 0$$

$$a\left(x^2 + \frac{b}{a}x + \frac{b^2}{4a^2}\right) + c = a\left(\frac{b^2}{4a^2}\right)$$

$$\left(x^2 + \frac{b}{a}x + \frac{b^2}{4a^2}\right) + \frac{c}{a} = \frac{b^2}{4a^2}$$

$$\left(x^2 + \frac{b}{a}x + \frac{b^2}{4a^2}\right) = \frac{b^2}{4a^2} - \left(\frac{4a}{4a}\right)\frac{c}{a}$$

$$\left(x + \frac{b}{2a}\right)^2 = \frac{b^2 - 4ac}{4a^2}$$

$$x + \frac{b}{2a} = \frac{\pm\sqrt{b^2 - 4ac}}{2a}$$
$$x = \frac{-b \pm \sqrt{b^2 - 4ac}}{2a}$$

Approach 2:  $ax^2 + bx + c = 0, a \neq 0$

$$4a(ax^2 + bx + c) = 4a(0)$$

$$4a^2x^2 + 4abx + 4ac = 0$$

$$4a^2x^2 + 4abx = -4ac$$

$$4a^2x^2 + 4abx + b^2 = b^2 - 4ac$$

$$(2ax + b)^2 = b^2 - 4ac$$

$$2ax + b = \pm\sqrt{b^2 - 4ac}$$

$$2ax = -b \pm \sqrt{b^2 - 4ac}$$

$$x = \frac{-b \pm \sqrt{b^2 - 4ac}}{2a}$$

### 7.14 Exercises

1.

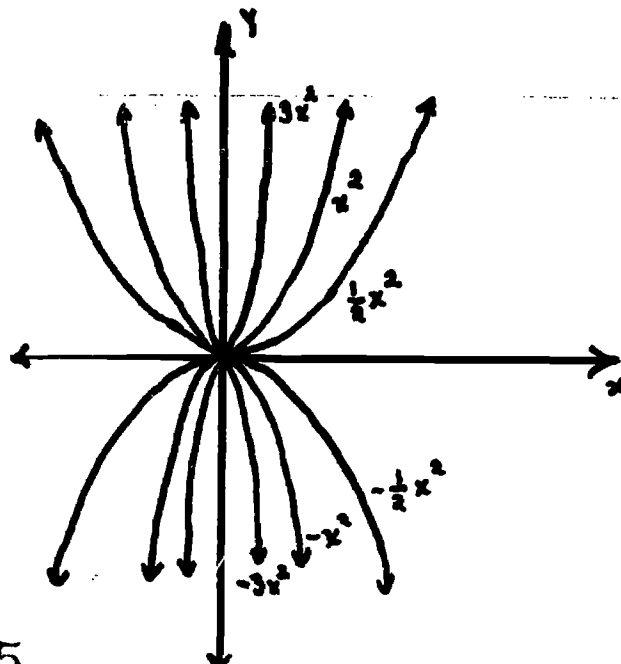

2.

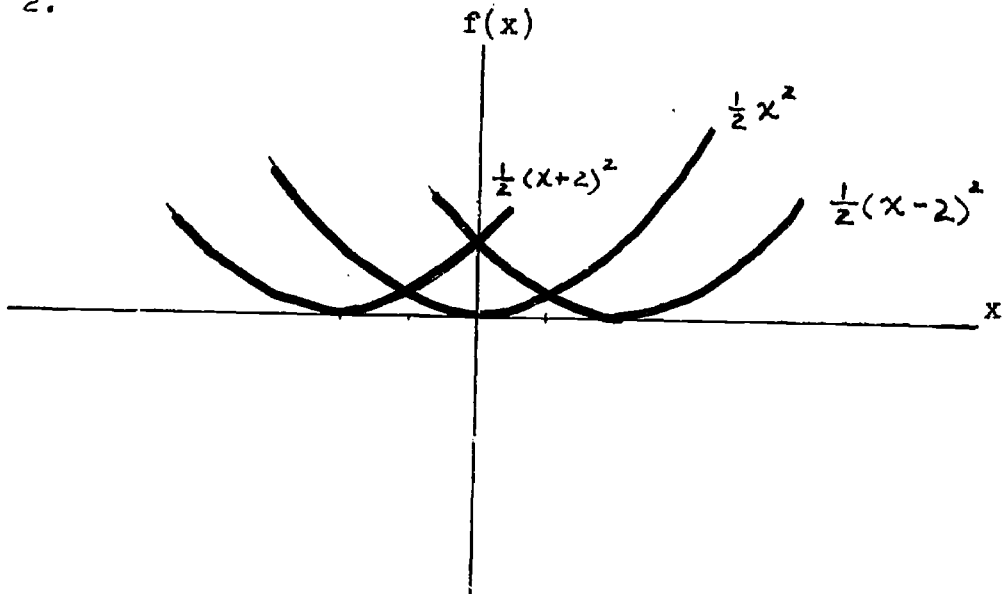

3.

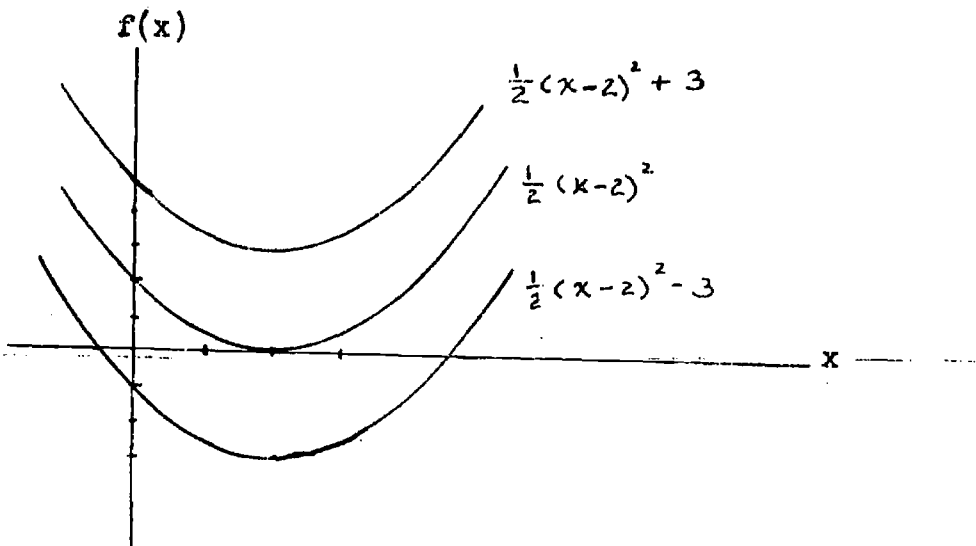

**NOTE:** Scales used in graphs indicate affine systems.

4. (a)  $(x - 6, y + \frac{3}{4})$   $[-6, \frac{3}{4}]$   
(b)  $(x + 2, y + 4)$   $[2, 4]$   
(c)  $(x + \frac{1}{2}, y - 3)$   $[\frac{1}{2}, -3]$   
(d)  $(x - 7, y - 10)$   $[-7, -10]$   
(e)  $(x + 0, y + 2)$   $[0, 2]$

5. (a)

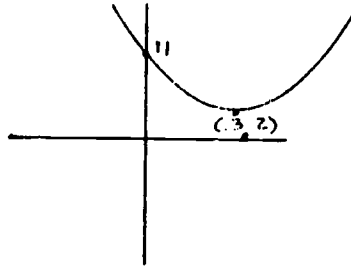

(b)

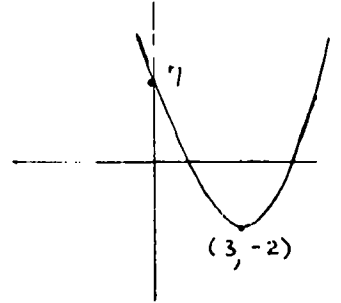

(c)

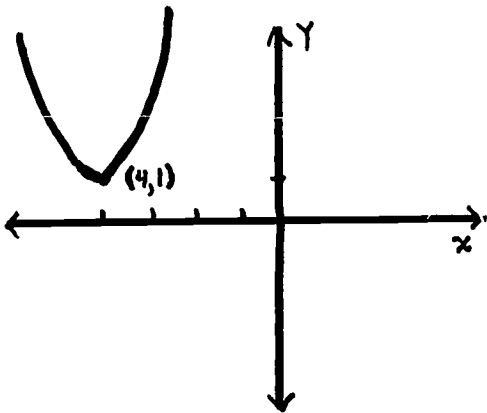

(d)

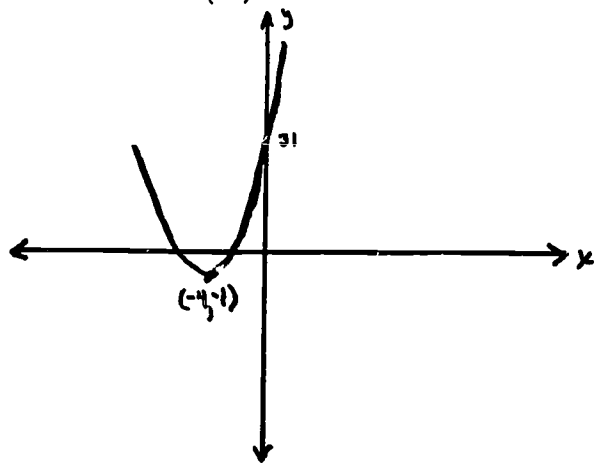

(e)

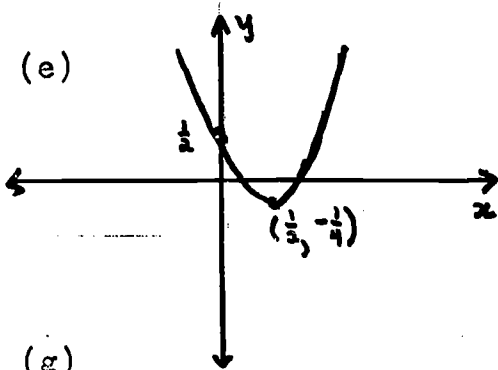

(f)

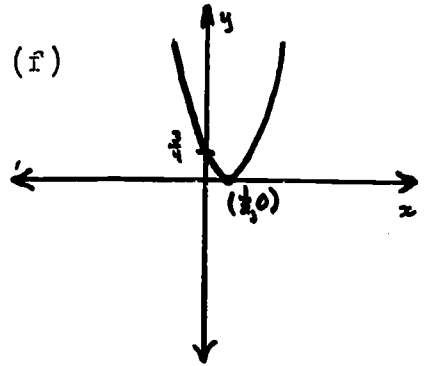

(g)

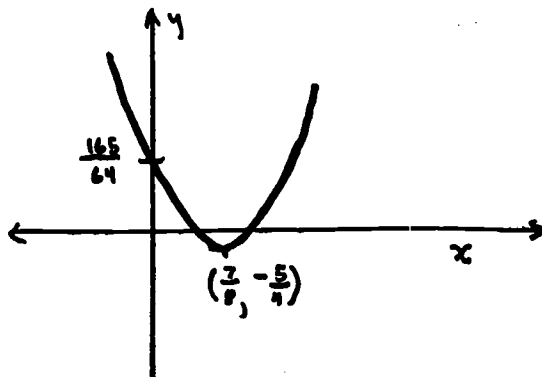

6. These problems should be approached from the concept of completing the square and finding the zeroes of the function as indicated in section 6.13.

(a)

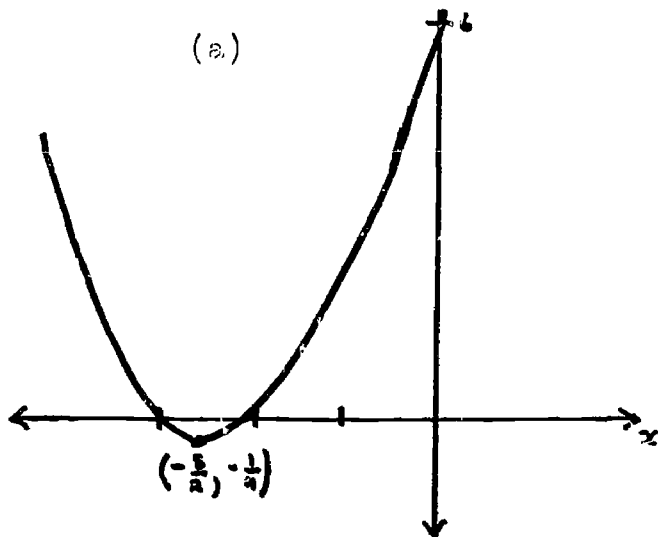

$$(x + \frac{5}{2})^2 - \frac{1}{4}$$

$\{-3, -2\}$  = zeroes of the function

(b)

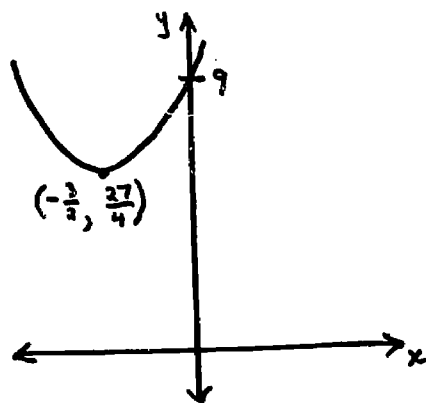

$$(x + \frac{3}{2})^2 + \frac{27}{4}$$

no real zeroes

(c)

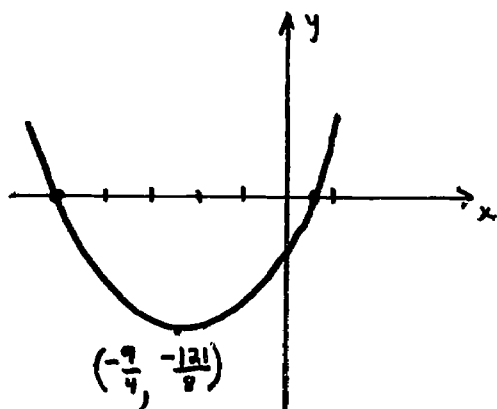

$\{\frac{1}{2}, -5\}$  = zeroes of the function

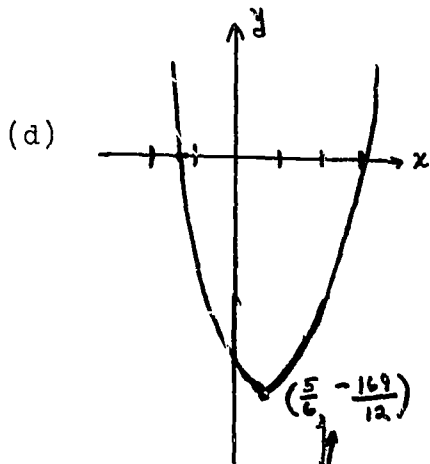

$$3(x - \frac{5}{6})^2 - \frac{169}{12}$$

$\{3, -\frac{4}{3}\} = \text{zero points}$

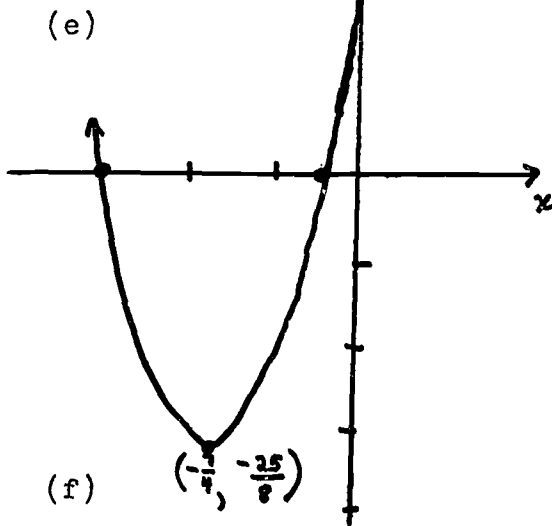

$$2(x + \frac{7}{4})^2 - \frac{25}{8}$$

$\{-3, -\frac{7}{2}\} = \text{zero points}$

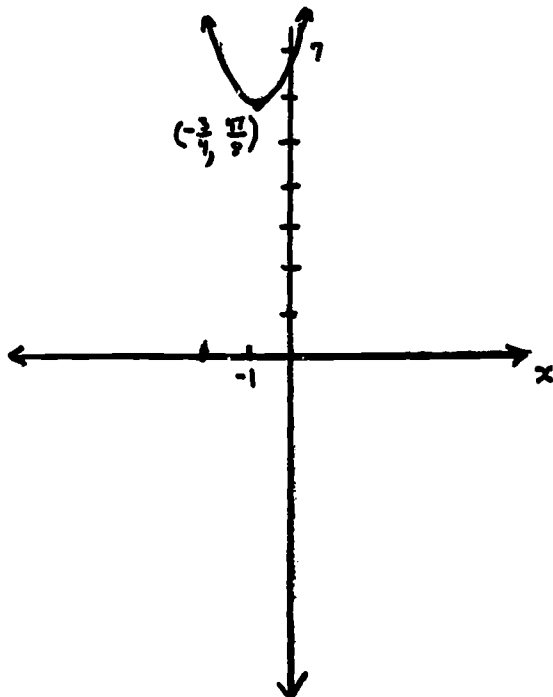

$$2(x + \frac{3}{4})^2 + \frac{47}{8}$$

no real zeroes

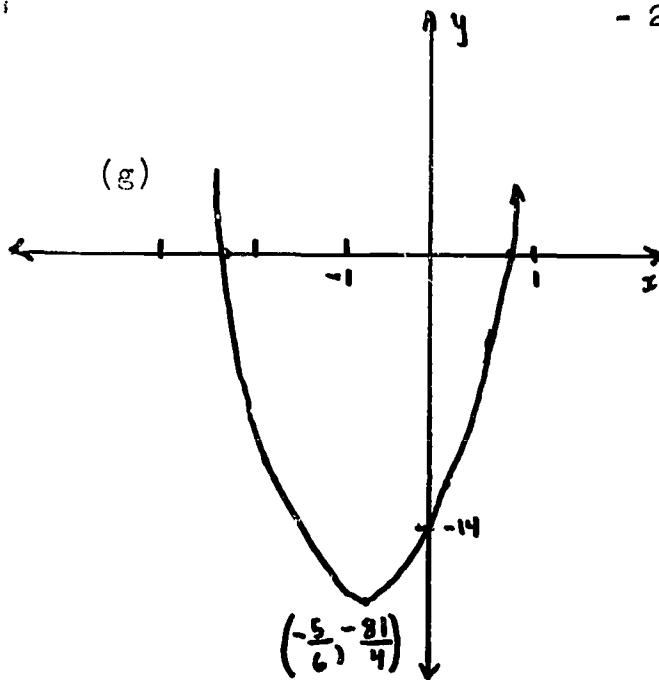

$$9\left(x + \frac{15}{18}\right)^2 - \frac{729}{36}$$

$$\text{or } 9\left(x + \frac{5}{6}\right)^2 - \frac{81}{4}$$

$$\left\{\frac{2}{3}, -\frac{7}{3}\right\} = \text{zero points}$$

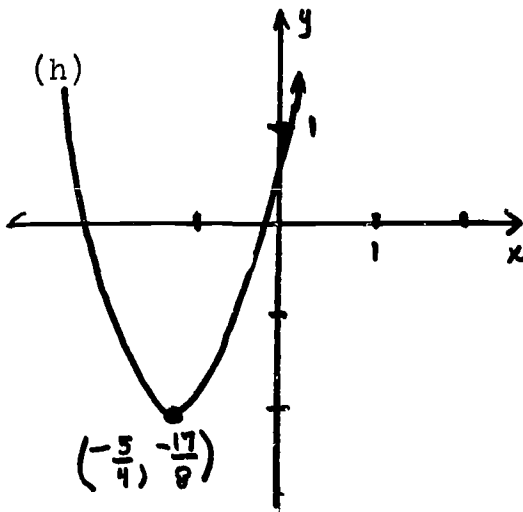

$$2\left(x + \frac{5}{4}\right)^2 - \frac{17}{8}$$

$$\left\{\frac{-5 + \sqrt{17}}{4}, \frac{-5 - \sqrt{17}}{4}\right\}$$

(i)

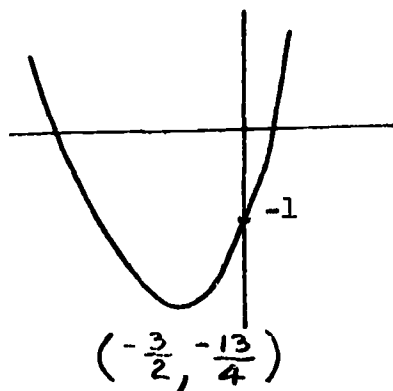

$$\left(x + \frac{3}{2}\right)^2 - \frac{13}{4}$$

$$\left\{\frac{-3 + \sqrt{13}}{2}, \frac{-3 - \sqrt{13}}{2}\right\}$$

(j)

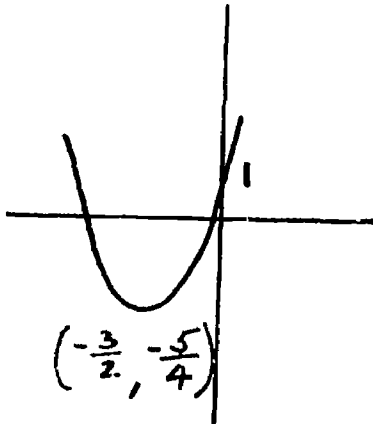

$$(x + \frac{3}{2})^2 - \frac{5}{4}$$

$$\{ \frac{-3 + \sqrt{5}}{2}, \frac{-3 - \sqrt{5}}{2} \}$$

(k)

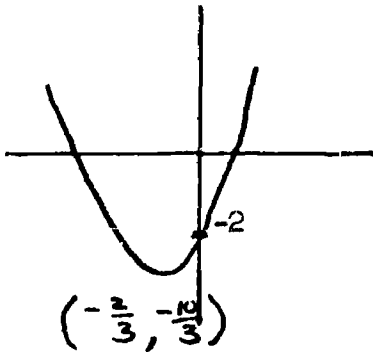

$$3(x + \frac{2}{3})^2 - \frac{10}{3}$$

$$\{ \frac{-2 + \sqrt{10}}{3}, \frac{-2 - \sqrt{10}}{3} \}$$

(1)  $a(x + \frac{b}{2a})^2 + \frac{4ac - b^2}{4a}$

(7)(a) 4, -3

(b)  $\frac{-1 \pm \sqrt{5}}{2}$

(c)  $\frac{1}{7}, -3$

(d) -1,  $\frac{1}{2}$

(e) no real solutions (f)  $-\frac{3}{2}, 1$

(g)  $-\frac{5}{3}, 1$

(h)  $\frac{1}{2}, 3$

(i)  $\frac{-b \pm \sqrt{b^2 - 4ac}}{2a}$

(8)(a)

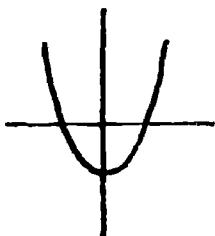

2 zero points

(b)

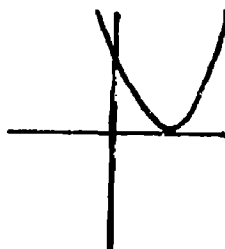

1 zero point

(c)

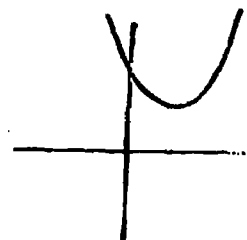

No zero points



7.15 Rational Functions (Time for 7.15, 7.16 = 1 to  $1\frac{1}{2}$  days)

The first definition of a rational function presented in this section is a natural extension of the definition of polynomial function. The generating functions in both cases are the same --  $j_R$  and  $c_a$ ,  $a \in R$ . However, in the case of a rational function, division is also permitted. Of course it is also useful to think of a rational function as simply the quotient of polynomial functions, and this is presented as a second and alternative definition in the section. Be sure students understand that every polynomial function is a rational function (denominator = 1).

Whereas the domain of a polynomial function presented no difficulty (unless there is some external reason to restrict the domain, it is always  $R$ ) the domain of a rational function is always important to consider. A rational function considered as the quotient of two polynomials  $p/q$  will never have the zeroes of  $q$  in its domain; the class might discuss once more the reason for this, the inability to define division by zero. We shall generally assume the domain of a rational function to be the greatest possible subset of  $R$ .

The graphs of rational functions included in this section and in the exercises are meant to be simply rough sketches and highly intuitive. Emphasis should be placed on using the excluded values to draw asymptotes, and on locating enough specific points to get an idea of how the graph "behaves". "Gets bigger and bigger", "gets closer and closer", etc. are phrases that probably will have much meaning for students in connection with these graphs.

7.16 Exercises

1. (a) yes (b) no (c) no (d) yes (e) yes (f) no
2. (a) Polynomial and rational (b) Rational  
 (c) Rational (d) Rational  
 (e) Rational (f) Neither  
 (g) Polynomial and rational (h) Polynomial and rational  
 (i) Neither (j) Polynomial and rational  
 (k) Rational (l) Neither
3. (a)  $R \setminus \{0\}$  (b)  $R \setminus \{3\}$   
 (c)  $R \setminus \{-5\}$  (d)  $R \setminus \{-5\}$   
 (e)  $R$  (f)  $R \setminus \{-7, 3\}$   
 (g)  $R \setminus \{-2, 5, -\frac{1}{2}\}$  (h)  $R \setminus \{0, 3, -12, -\sqrt{2}\}$

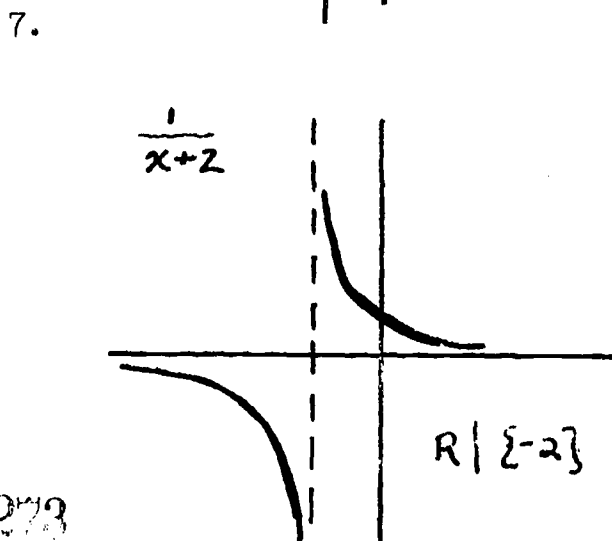
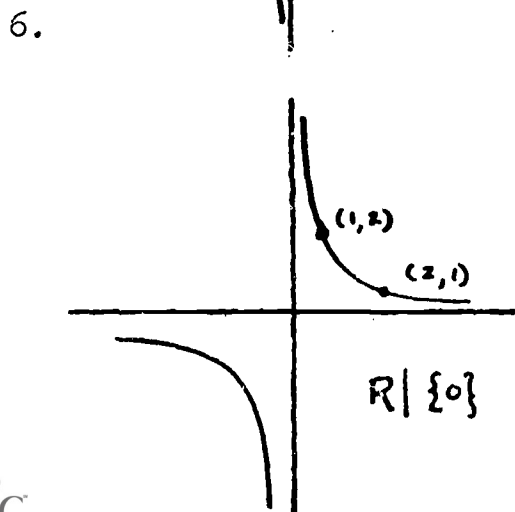
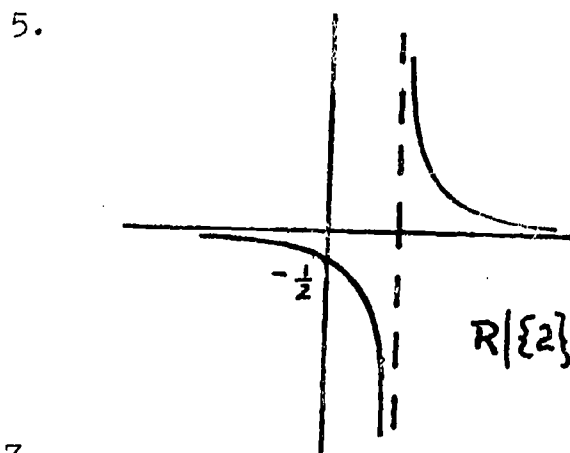
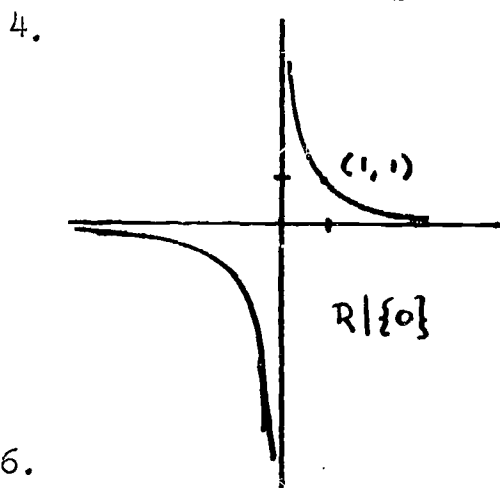

8.

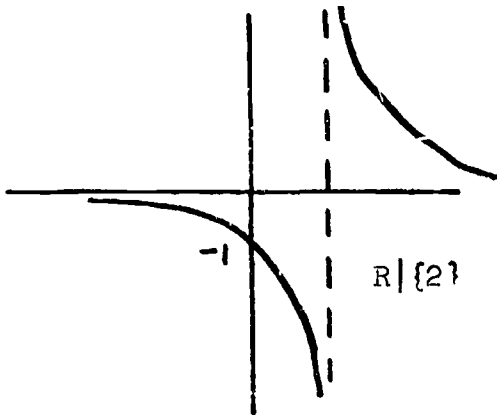

9.

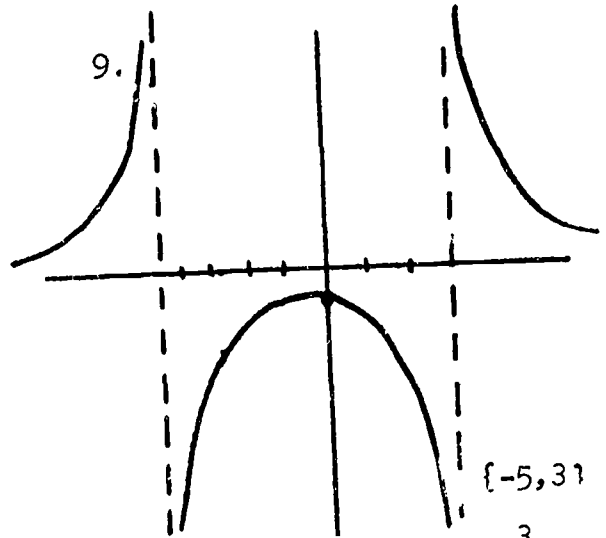

10.

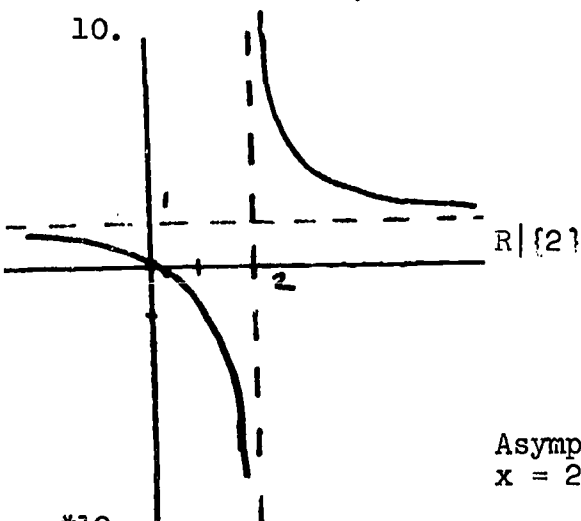

11.

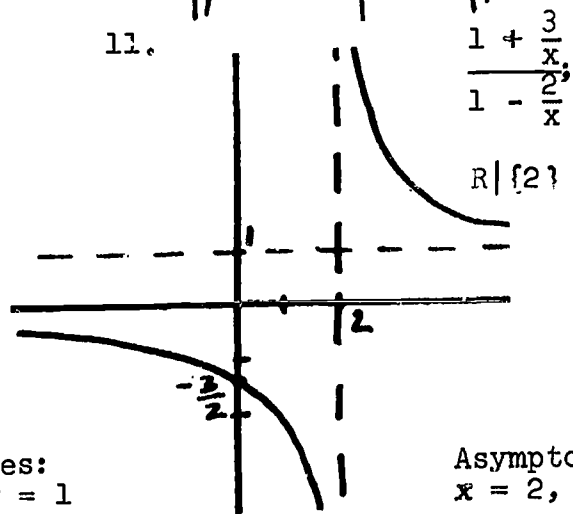

$$\frac{1 + \frac{3}{x}}{1 - \frac{2}{x}}$$

Asymptotes:  
 $x = 2; y = 1$

Asymptotes:  
 $x = 2, y = 1$

\*12.

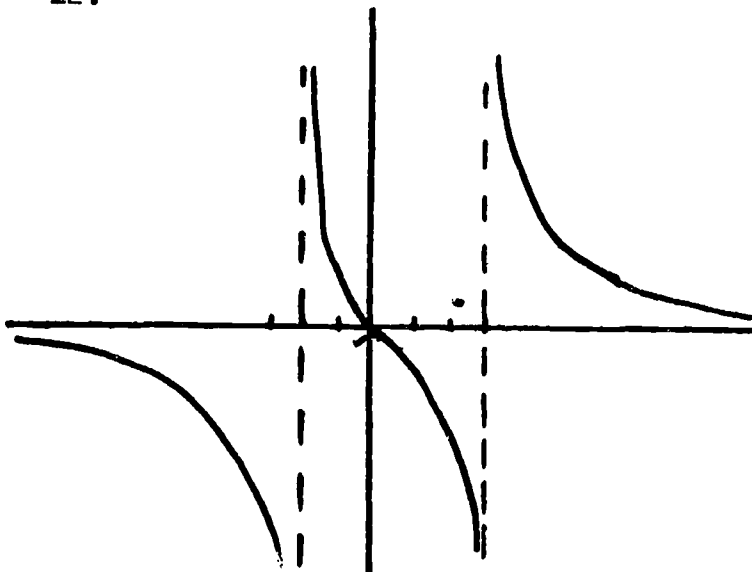

$R \setminus \{3, -2\}$

### 7.17 Operations with Rational Functions

(Time for 7.17, 7.18 = 3 to  $3\frac{1}{2}$  days)

The work of this section is concerned with the now familiar concept of operations on functions. This time, however, the functions are rational functions, and the work is done primarily by means of the associated rational expressions. Thus the student encounters the traditional high school algebra content of "algebraic fractions". Also traditionally, this work has not been easy for students, and the examples in the text will almost surely have to be explained carefully and buttressed by similar examples.

Again it is important to emphasize the domain of rational functions. In a division problem the zeroes of the numerator of the divisor must also be excluded. As an example, in  $\frac{x+3}{x+4} \div \frac{x-2}{x-7}$ , the domain is  $R \setminus \{-4, 2, 7\}$ .

The text does not discuss the structure of  $(RF, +, \cdot)$ , where  $RF$  is the set of rational functions. This is because of some inherent difficulties whose resolution would only add to the length of an overlong chapter. For instance, while the function  $c_1$  is surely the identity function for multiplication, the product of  $x$  and  $\frac{1}{x}$  is not exactly the function  $c_1$ , whose domain is  $R$ , but rather the function  $x \longrightarrow 1$ , with domain  $R \setminus \{0\}$ . Similarly, the product  $(x-2) \cdot \frac{1}{x-2}$  is not  $c_1$ , but the function  $x \longrightarrow 1$ , with domain  $R \setminus \{2\}$ . A similar difficulty arises in the additive structure. Here  $c_0$  is the identity.

Yet  $\frac{1}{x} + \frac{-1}{x}$  is not  $c_0$ , but the function  $x \longrightarrow 0$ , with domain  $R \setminus \{0\}$ . In this connection, see Exercises 3 and 4 of Section 7.18. Except for these difficulties with domain,  $(R, +, \cdot)$  would of course be a field.

Even so, analogy with the field of rational numbers is probably a good one to emphasize. The text does some of this, and Exercise 1 of Section 7.18 is directed to this analogy, helping students relate new learning to old.

### 7.18 Exercises

1. (a)  $\frac{22}{15}$   $\frac{8x - 5}{(x + 2)(x - 5)}$  or  $\frac{8x - 5}{x^2 - 3x - 10}$
  - (b)  $\frac{29}{105}$   $\frac{3x^2 - x}{(x - 2)(x + 1)(x + 3)}$  or  $\frac{3x^2 - x}{x^3 + 2x^2 - 5x - 6}$
  - (c)  $\frac{10}{21}$   $\frac{(x + 2)(x + 5)}{(x - 12)(x^2 - x)}$  or  $\frac{x^2 + 7x + 10}{x^3 - 13x^2 + 12x}$
  - (d)  $\frac{15}{49}$   $\frac{5x^2}{x - 2}$
2. (a)  $\frac{x^2 - 3x + 12}{(x - 7)(x + 3)}$   $R \setminus \{7, -3\}$
  - (b)  $\frac{-x^2 + 11x + 12}{(x - 7)(x + 3)}$   $R \setminus \{7, -3\}$
  - (c)  $\frac{4x}{(x - 7)(x + 3)}$   $R \setminus \{7, -3\}$
  - (d)  $\frac{x^2 + 4x + 12}{(x - 7)(x + 3)}$   $R \setminus \{7, -3\}$
  - (e)  $\frac{7x}{(x - 7)(x + 3)}$   $R \setminus \{7, -3\}$
  - (f)  $\frac{4x + 12}{x^2}$   $R \setminus \{0, 7, -3\}$
  - (g)  $\frac{x^2 - 3x + 12}{x^2}$   $R \setminus \{0, 7, -3\}$

3. (a)

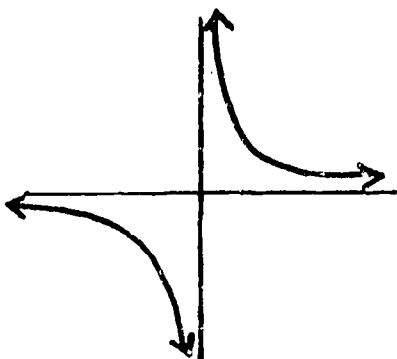

(b) by  $T_{5,0}$

(c)  $\frac{1}{x(x-5)}$   $R \setminus \{0,5\}$

$(x - 5)$  is a polynomial function with domain  $R \setminus \{5\}$ . Therefore  $a(x - h) + k$ , where  $h = 5$ ,  $k = 0$ .

4. (a)

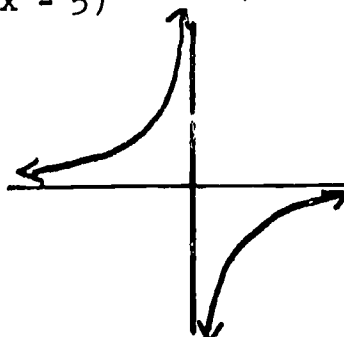

(b) Reflection in  $x$  - axis  $(a,b) \in f \Rightarrow (a,-b) \in h$

(c)  $\frac{0}{x}$   $R \setminus \{0\}$

(d) False (not true for  $x = 0$ )

5.  $\frac{x^2 + 6x - 10}{x(x + 5)}$   $x \neq 0, -5$

6.  $\frac{x^2 + 4x}{(x + 2)(x - 2)}$   $x \neq 2, -2$

7.  $\frac{x + 3}{x + 2}$   $x \neq 2, -2, 3$

8. 1  $x \neq 2$

9. 0  $x \neq 0$

10.  $\frac{x + 3}{x^2 + 3}$   $x \neq 2, -3$

11.  $\frac{25}{x^2}$   $x \neq 0$

12.  $\frac{x^2 + 2x + 4}{x + 2}$   $x \neq -2, 2$
13.  $\frac{13x^2 - 6x - 1}{(3x + 1)(5x - 2)}$   $x \neq -\frac{1}{3}, \frac{2}{5}$
14.  $\frac{13x^3 - 6x - 1}{(3x + 1)(5x - 2)}$   $x \neq -\frac{1}{3}, \frac{2}{5}$
15.  $\frac{x + 7}{(x - 7)(x - 2)}$   $x \neq 7, 2, 5, -7, -2$
16.  $\frac{x^3 - 5x^2 - 9x + 115}{(x + 2)(x - 3)(x - 5)}$   $x \neq -2, 3, 5$

#### 7.19 Summary

#### 7.20 Review Exercises

1. (a) polynomial and rational  
(b) neither  
(c) neither  
(d) polynomial and rational  
(e) rational
- 2 (f) rational  
(g) polynomial and rational  
(h) rational  
(i) neither  
(j) polynomial and rational
2.  $7x^3 - \frac{1}{2}x^2 + x - \frac{1}{6}$
3.  $x^3 - 15x^2 + 43x - 84$
4.  $\frac{1}{4}x^3 - 4x^2 + 17x + \frac{42}{3}$
5.  $x^2 - 2$
6.  $9x^2 + 42x + 49$

7.  $6x^3 - 42x^2 + 14x - 98$

8. 0

9.  $8x^3 - 16x^2 - 20$

10.  $x^3 - 21x^2 + 147x - 343$

11. (a)  $q(x) = 2x - \frac{17}{2}$   $r(x) = \frac{105}{2}$

(b)  $q(x) = x^2 + 2x + 4$   $r(x) = 0$

(c)  $q(x) = x^2 + x + 1$   $r(x) = -7$

(d)  $q(x) = \frac{1}{2}x + \frac{9}{4}$   $r(x) = \frac{33}{4}$

12. (a)  $(3x - 2)(2x + 7)$

(b) prime over integers

(c)  $(5x - 2)(5x - 2)$

13. (a)  $2(x + 1)^2 - 2$

$T_{-1, -2}$

(b)  $2(x - \frac{7}{4})^2 - \frac{49}{8}$

$T_{\frac{7}{4}, -\frac{49}{8}}$

(c)  $2(x + \frac{1}{4})^2 + \frac{39}{8}$

$T_{-\frac{1}{4}, \frac{39}{8}}$

(d)  $2(x - \frac{3}{4})^2 + \frac{55}{8}$

$T_{\frac{3}{4}, \frac{55}{8}}$

14.

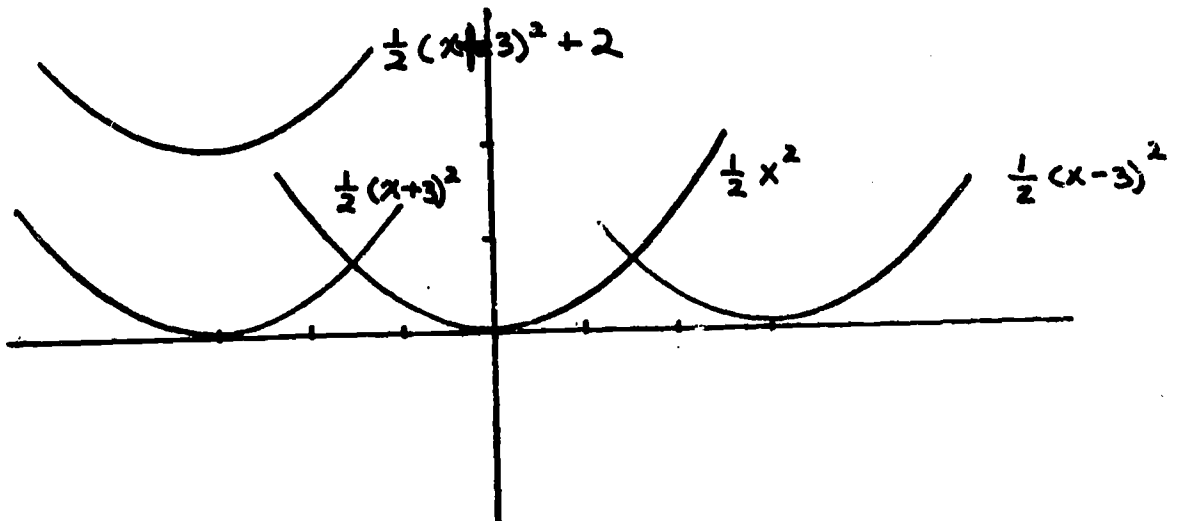



15. (a) -4, -3 (b) -3, 1  
 (c) no real zeroes (d)  $\frac{3}{2}$
16. (a)  $\{\sqrt{7}, -\sqrt{7}\}$  (b) no real solutions  
 (c)  $\{-\frac{3}{2}, 5\}$  (d)  $\{-1 + \sqrt{3}, -1 - \sqrt{3}\}$   
 (e)  $\{0, \frac{1}{3}\}$  (f)  $\{\frac{3 + \sqrt{41}}{4}, \frac{3 - \sqrt{41}}{4}\}$

17.

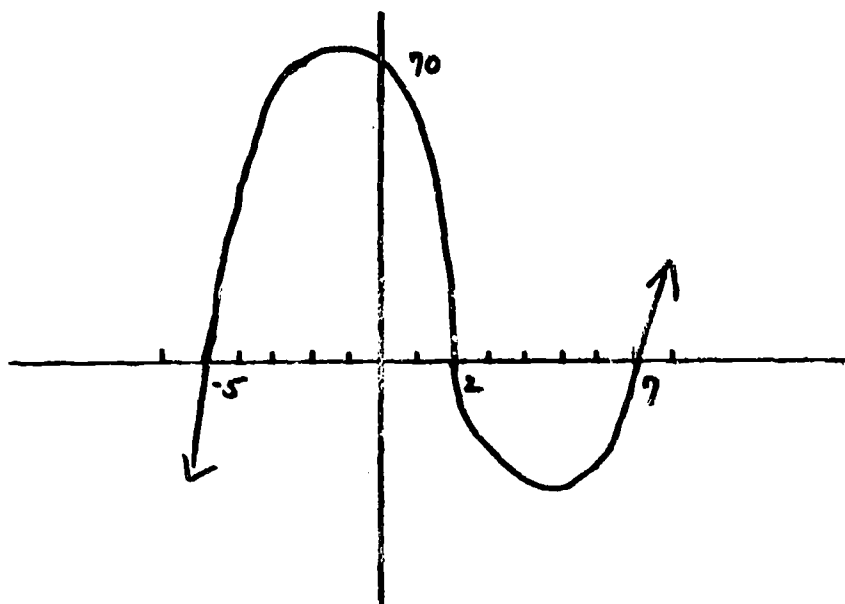

$x \longrightarrow (x-7)(x-2)(x+5)$  becomes

$x \longrightarrow x^3 - 4x^2 - 31x + 70.$

This is a polynomial function since it can be expressed as the addition and multiplication of the identity function,  $J_R$ , and the constant functions  $(c_{-4}, c_{-31}, c_{70})$ .

18. (a)

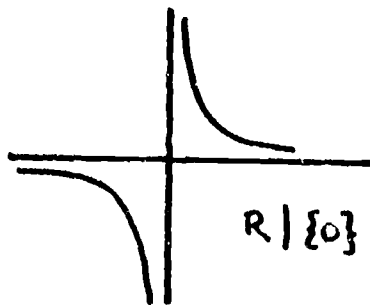

(b)

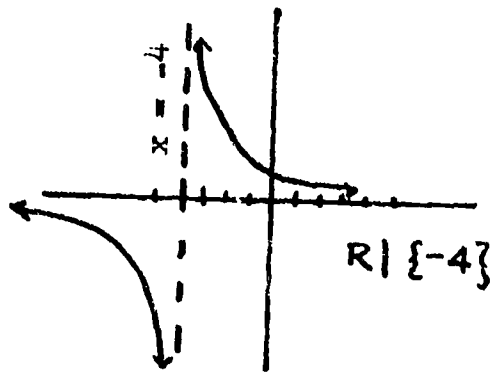

(c)

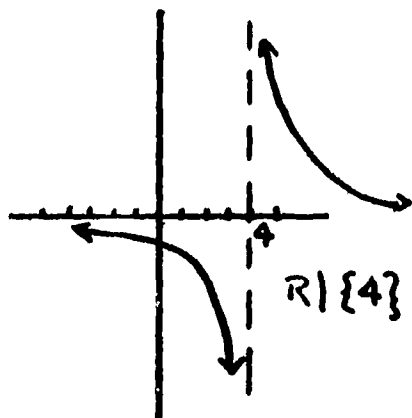

(d)

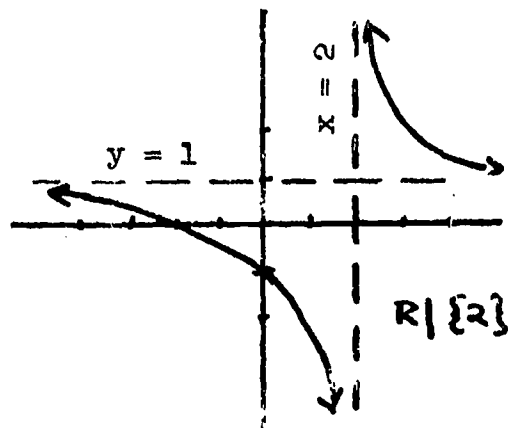

SAMPLE ITEMS:    CHAPTER TEST ON POLYNOMIAL FUNCTIONS

Part I:    Select the best answer and rewrite the "letter" only at the right.

1. Which is NOT a polynomial: 1. \_\_\_\_\_  
(a)  $x^3 - \frac{3}{5}x$     (b)  $x^2 + 7$     (c)  $x - \frac{1}{x}$     (d)  $5 + \sqrt{x}$
2. Which polynomial functions represent the polynomial  $(2x^3)$ ? 2. \_\_\_\_\_  
(a)  $c_2 \cdot j_R \cdot c_3$     (b)  $c_2 \cdot j_R \cdot j_R \cdot j_R$     (c)  $c_2 \cdot j_R \cdot c_2 \cdot j_R \cdot c_2 \cdot j_R$     (d) none
3. Which of the following is equivalent to  $(c_{-2} \cdot j_R)$ ? 3. \_\_\_\_\_  
(a)  $j_R \cdot j_R$     (b)  $c_{-1} \cdot j_R \cdot j_R$     (c)  $c_{-1} \cdot j_R + c_{-1} \cdot j_R$     (d)  $c_{-1} + c_{-1}$
4. The degree of the function  $x \rightarrow 0$  is: 4. \_\_\_\_\_  
(a) 1    (b) 0    (c) none
5.  $3x^2 + \sqrt{9}x - \frac{1}{2}$  is NOT a polynomial over the! 5. \_\_\_\_\_  
(a) reals    (b) rationals    (c) integers
6. If  $\deg(f) = 3$  and  $\deg(g) = 4$ , then  $\deg(f \cdot g) =$  6. \_\_\_\_\_  
(a) 4    (b) 7    (c) 12    (d) 4 or less
7. If  $\deg(f) = 3$  and  $\deg(g) = 3$ , then  $\deg(f + g) =$  7. \_\_\_\_\_  
(a) 3    (b) 6    (c) 9    (d) 3 or less
8. Which is NOT a commutative ring with unity? 8. \_\_\_\_\_  
(a)  $(Z, +, \cdot)$     (b)  $(R, +, \cdot)$     (c)  $(Z_5, +, \cdot)$     (d)  $(W, +, \cdot)$
9. The domain of  $\frac{x+3}{x+4} \div \frac{x-1}{x-2}$  is: 9. \_\_\_\_\_  
(a)  $R$     (b)  $R \setminus \{-4, 2\}$     (c)  $R \setminus \{-4, 1\}$     (d)  $R \setminus \{-4, 1, 2\}$
10. Given  $f: x \rightarrow 3x^2 - 2x + 1$ , the value of  $f(-2)$  is: 10. \_\_\_\_\_  
(a) 5    (b) 9    (c) 17    (d) 41
11. For  $(x^2 + 6x + k)$  to be a perfect square polynomial, 11. \_\_\_\_\_  
k must equal: (a) 3    (b) 9    (c) 12    (d) 36
12. The zeroes in  $R$  of the function  $k$  are 3 and 2. Which is 12. \_\_\_\_\_  
the function  $k$ ? (a)  $x^2+6$     (b)  $x^2+5x+6$     (c)  $x^2-5x+6$     (d)  $(x+3)(x+2)$

Part II - Answer all questions with regard to the polynomial:

$$0x^5 + 3x^4 + -2x^3 + 7x - 8.$$

1. What is the coefficient of  $x$ ? \_\_\_\_\_
2. What is the constant term? \_\_\_\_\_
3. What is the degree of the polynomial? \_\_\_\_\_
4. What is the leading coefficient? \_\_\_\_\_
5. What is the coefficient of  $x^3$ ? \_\_\_\_\_
6. What is the coefficient of  $x^2$ ? \_\_\_\_\_
7. What is the exponent of  $7x$ ? \_\_\_\_\_
8. What is  $a_4$ ? \_\_\_\_\_

Part III -  $f(x) = x^2 - 4$  ;  $g(x) = x + 2$  ;  $h(x) = x - 5$

Perform the operations as indicated and simplify all answers.

1.  $[g \cdot h](x) =$
2.  $[g \cdot g](x) =$
3.  $[f - g \cdot g](x) =$
4.  $[f - h](x) =$
5.  $[f + g](x) =$
6.  $[f \div g](x) =$

Part IV:

Perform the indicated operations: (Simplify your answers)

1.  $(3x - 8)(2x^2 - 5)$  1) \_\_\_\_\_
2.  $(4x^2 - 7x + 10) + (x^3 - 2x - 5)$  2) \_\_\_\_\_

3.  $(x^2 - 3x + 7) - (5x^2 - x - 4)$  3. \_\_\_\_\_
4.  $\frac{2x^2}{x^2 - 9} + \frac{4x}{x - 3}$  4. \_\_\_\_\_
5.  $\frac{x^2 + 10x + 25}{2x + 6} \div \frac{x^2 - 25}{x^2 - 2x - 15}$  5. \_\_\_\_\_
6.  $3(2x^2 - 6x + 4) - 2(3x^2 + 9x + 6)$  6. \_\_\_\_\_
7.  $(2x - 5)(2x - 5)$  7. \_\_\_\_\_
8.  $(2x - 5)(2x + 5)$  8. \_\_\_\_\_
9.  $(2x - 5)(3x + 1)$  9. \_\_\_\_\_
10.  $(x^2 + x + 1)(x - 1)$  10. \_\_\_\_\_

Part V:

Identify each of the following as a polynomial expression, a rational expression, both, or neither.

1.  $\frac{1}{2}x^2 + 3x$  1. \_\_\_\_\_
2.  $x^3 + \frac{3}{x}$  2. \_\_\_\_\_
3.  $x^3 + \sqrt{3}x^2 + 5$  3. \_\_\_\_\_
4.  $x^3 + 2x^2 + \sqrt{x} + 5$  4. \_\_\_\_\_
5. 3 5. \_\_\_\_\_

Part VI:

Write each of the following in the form  $3(x - h)^2 + k$ . Then tell how the graph of that function can be obtained from the graph of  $f: x \rightarrow 3x^2$ .

1.  $3x^2 + 6x$  1. \_\_\_\_\_
- \_\_\_\_\_

2.  $3x^2 - 2x + 5$

2. \_\_\_\_\_  
\_\_\_\_\_

Part VII:

For each of the following pairs of polynomials,  $f$  and  $p$ , find polynomials  $q$  and  $r$ , with  $r = c_0$  or  $\deg(r) < \deg(p)$ , such that  $f = ([p \cdot q] + r)$ .

1.  $f(x) = 6x^2 - 7x + 10$   
 $p(x) = 3x + 4$

1.  $q$ : \_\_\_\_\_  
 $r$ : \_\_\_\_\_

2.  $f(x) = x^3 - 27$   
 $p(x) = x - 3$

2.  $q$ : \_\_\_\_\_  
 $r$ : \_\_\_\_\_

3.  $f(x) = x + 1$   
 $p(x) = x^2$

3.  $q$ : \_\_\_\_\_  
 $r$ : \_\_\_\_\_

Part VIII: Find the zeroes in  $R$  of the following quadratic functions.

1.  $x^2 - 8x + 16$

1. \_\_\_\_\_

2.  $x^2 - 5$

2. \_\_\_\_\_

3.  $2x^2 + 7x + 3$

3. \_\_\_\_\_

4.  $5x^2 - 4x$

4. \_\_\_\_\_

5.  $2x^2 + 4x - 1$

5. \_\_\_\_\_

Answer Key for Chapter Test

- Part I: 1. c    4. c    7. d    10. c  
2. b    5. c    8. d    11. b  
3. c    6. b    9. d    12. c

- Part II: 1. 7    4. 3    7. 1  
2. -8    5. -2    8. 3  
3. 4    6. 0

- Part III: 1.  $x^2 - 3x - 10$                       4.  $x^2 - x + 1$   
2.  $x^2 + 4x + 4$                                 5.  $x^2 + x - 2$   
3.  $-4x - 8$                                       6.  $x - 2$

- Part IV: 1.  $6x^3 - 16x^2 - 15x + 40$             6.  $-36x$   
2.  $x^3 + 4x^2 - 9x + 5$                         7.  $4x^2 - 20x + 25$   
3.  $-4x^2 - 2x + 11.$                             8.  $4x^2 - 25$   
4.  $\frac{6x^2 + 12x}{x^2 - 9}$                                     9.  $6x^2 - 13x - 5$   
5.  $\frac{x + 5}{2}$     10.  $x^3 - 1$

- Part V: 1. Both                                    3. Both                                    5. Both  
2. Rational                                    4. Neither

- Part VI: 1.  $3(x + 1)^2 - 3$                       2.  $3(x - \frac{1}{3})^2 + \frac{14}{3}$   
Translation  $-1, -3$                               Translation  $\frac{1}{3}, \frac{14}{3}$

- Part VII : 1. q:  $2x - 5$                               r: 30  
2. q:  $x^2 + 3x + 9$                                 r: 0  
3. q: 0    r:  $x + 1$

- Part VIII: 1. 4                                        2.  $\sqrt{5}, -\sqrt{5}$                               3.  $-\frac{1}{2}, -3$   
4.  $0, \frac{4}{5}$     5.  $-1 + \frac{\sqrt{6}}{2}, -1 - \frac{\sqrt{6}}{2}$

## Chapter 8

### CIRCULAR FUNCTIONS

Time Estimate: 18 - 22 days

The basic concepts of mapping and function have played a prominent role in preceding chapters and in earlier courses; and two special classes of functions--polynomial and rational--have been studied rather extensively. In this chapter the function theme is picked up once again, this time with the introduction of the circular--or trigonometric--functions. These functions differ markedly from the algebraic functions encountered earlier; one of these differences, the property of periodicity, is cited in the introduction, although a fuller appreciation of periodicity must await the introduction of a wrapping function in Course IV.

Traditionally, the study of trigonometry has begun with the problem of solving right triangles, moving on to the solution of triangles in general. While this topic has some importance (e.g., resolving forces in physics) it is an outgrowth of a more analytic study of the circular functions, rather than a beginning point. Thus, in the present chapter, triangle solving appears in the final section, 8.15.

The chapter begins with a definition of sensed angles. The geometric concept of angle, introduced in Course I, is not sufficient for analysis. For example, the angle shown at the right must be construed as measuring either  $90^\circ$  or  $270^\circ$ , and injecting the notion of order to pairs of coterminal

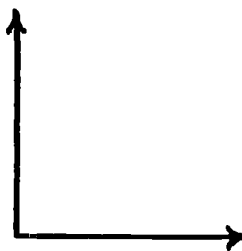



rays allows for this.

Sensed angles in fact play an important part in the entire chapter. The first circular functions developed, SINE and COSINE, are functions of sensed angles; functions of numbers are introduced in a subsequent section. In this chapter, we confine ourselves to a measure function ( $m$ ) which assigns to sensed angles only numbers between 0 and  $2\pi$  (not including  $2\pi$ ). With the introduction of a wrapping function in Course IV, any real number may be interpreted as an angle measure. Even so, the measures assigned by the  $m$  function remain the principal measures, and so assume special importance.

Following is a list of the major topics (concepts and skills) of the chapter:

Definition of sensed angle

Congruence of sensed angles

Standard position of a sensed angle

Measuring sensed angles ( $m$  function)

Circular functions of angles: SINE and COSINE

Circular functions of numbers: sine and cosine

Addition of sensed angles

Graphs of circular functions

Solution of triangles: Law of Sines and Law of Cosines

### 8.1 Sensed Angles ( $1\frac{1}{2}$ - 2 days)

The specific purpose of this section is to present the definition of sensed angle--i.e., to introduce the notion of

order when considering a pair of coterminal rays. Notice that the definition here involves simply the rays themselves, not the region "bounded" by them; this stands in contrast to the earlier work with geometric angles.

The definition of congruent sensed angles is made in terms of direct isometries, a concept of transformation geometry with which students should be familiar by this time. For background here, we offer a rationale for this definition, though it would probably mean little to students at this

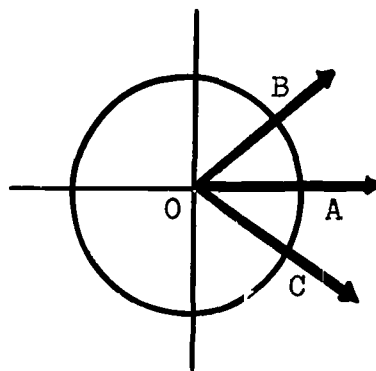

time. In the accompanying diagram,  $\angle AOB$  and  $\angle AOC$ , as geometric angles, are congruent. However, considering the sensed angles,  $\vec{\angle}AOB$  and  $\vec{\angle}AOC$ , the SINES of the angles are not the same; the SINE of  $\vec{\angle}AOB$  is positive, whereas the SINE of  $\vec{\angle}AOC$  is negative. Also, the two sensed angles do not have the same measure; the measure of  $\vec{\angle}AOB$  is  $45^\circ$ , while the measure of  $\vec{\angle}AOC$  is  $315^\circ$ , or  $-45^\circ$ . Hence, because we want congruent sensed angles to have the same measure and the same SINE (i.e., we want the same assignments made to all members of a congruence equivalence class), we do not want the angles AOB and AOC above to be congruent. And the definition of congruent sensed angles makes it clear that these two angles are indeed not congruent, for there is no direct isometry mapping initial side onto initial side and terminal side onto terminal side.

Note that the definition of sensed angle does not rule out "straight angles" (where the two rays are distinct but collinear)

and "zero angles" (where the two rays of the pair are indeed the same ray). Such angles in fact play a crucial role in analysis; they are introduced in Exercises 9, 10, and 11 of Section 8.2 and should not be omitted.

### 8.2 Exercises

1. (a)  $\overrightarrow{RD}$  and  $\overrightarrow{RN}$  (b)  $\overrightarrow{XC}$  and  $\overrightarrow{XR}$   
(c)  $\overrightarrow{LG}$  and  $\overrightarrow{LT}$  (d)  $\overrightarrow{EO}$  and  $\overrightarrow{EA}$
2. (a) False--no direct isometry will map initial side onto initial side and terminal side onto terminal side.  
(b) True--for instance, a translation carrying E to H, followed by a rotation, will map one angle on the other; both of these are direct isometries.  
(c) False (d) True
3. (a) Translation mapping B on E  
(b) Yes, since a direct isometry maps initial side onto initial side and terminal side.  
(c) Translation mapping E on B  
(d) Yes  
(e) Yes, it is symmetric; the inverse of a direct isometry is also a direct isometry.
4.  $\angle RTN \cong \angle ASD$   
 $(\overrightarrow{TN}, \overrightarrow{TR}) \cong (\overrightarrow{SD}, \overrightarrow{SA})$   
 $\angle NTR \cong \angle DSA$
5. (a) Identity transformation  
(b) Yes  
(c) Yes

- (d) Yes
  - (e) No--a single line reflection would give the required mapping, but this is not a direct isometry
6. (a) Translation mapping B on E
- (b) Yes
  - (c) Translation mapping E on H
  - (d) Yes
  - (e) Translation mapping B on H
  - (f) Yes
  - (g) Yes (the preceding parts are an illustration of this)
7. Yes, since it is reflexive, symmetric, and transitive. (Note therefore that a single sensed angle may be taken as representative of an entire equivalence class of sensed angles. In later sections a standard position sensed angle will often be taken as such a representative.)
8. (a) Translation, mapping S onto M, followed by a rotation
- (b) Yes--the two mappings in part a are both direct isometries; thus their composition is also a direct isometry.
  - (c) No--a line reflection will be required, which makes the isometry an opposite one rather than direct.
9. (a) Yes
- (b) Half-turn
10. (a) Yes; translation--D to B--followed by rotation
- (b) Yes; translation followed by rotation
11. (a) Yes; translation--O to A--followed by rotation
- (b) Yes; translation followed by rotation will give the

required mapping.

12. [Student construction]

8.3. Standard Position (1 -  $1\frac{1}{2}$  days)

Standard position of a sensed angle is introduced in the usual way: the initial side of the angle is the "positive half" of the x-axis. The work with ratio of arc length to radius of circle should be treated lightly and intuitively, passing quickly to the unit circle on which all later work will be based.

The m function introduced in this section is to play an important role in following sections, both in this course and subsequent ones. Essentially it assigns a unique real number between 0 and  $2\pi$  (not including  $2\pi$ ) to each sensed angle in standard position. Thus it is a one-to-one mapping from the set SPSA (standard position sensed angles) to the set  $[0, 2\pi)$ . (Be sure students understand that the symbol " $[0, 2\pi)$ " indicates that 0 is included, but  $2\pi$  excluded.) Later, in Course IV, a wrapping function will be introduced so that an infinite number of numbers (or "measures") may be associated with a given angle; for example, a quarter-turn may be associated not only with  $\frac{\pi}{2}$ , but also with  $\frac{5\pi}{2}$ ,  $\frac{3\pi}{2}$ , etc. Nevertheless, the numbers assigned by the m function will remain the principal measures.

Notice that the choice of  $[0, 2\pi)$  as the range of m means that intuitively we move counterclockwise, about the unit circle to determine the arc length for a given angle in standard position. Thus for a three-quarter turn, the arc length is  $\frac{3\pi}{2}$ , not  $\frac{\pi}{2}$ .

In Section 8.7, trigonometric functions of real numbers will be developed by means of composition of functions. One of the functions in the composition is the function  $m^{-1}$ . Therefore, the inverse of the  $m$  function merits some attention in the present section. Since  $m$  is one-to-one and onto, it has an inverse; the domain is  $[0, 2\pi)$ , and the range is SPSA. Some of the exercises in Section 8.4 (see, for instance, Exercise 8) deal with this inverse function.

It was established in Exercise 7 (and preceding exercises) of Section 8.2 that congruence of sensed angles is an equivalence relation. Thus every sensed angle, in standard position or not, is congruent to some standard position sensed angle. Emphasize the principle stated in this section to the effect that all angles in the same equivalence class are assigned the same measure. Thus the  $m$  function indirectly determines a measure for every sensed angle.

#### 8.4 Exercises

1. For radius 3, circumference is  $6\pi$ . Thus  $\theta$  is  $\frac{1}{6} \times 6\pi$ , or  $\pi$ .  
Since  $r=3$ ,  $\frac{\theta}{r} = \frac{\pi}{3}$ .

For radius 2, circumference is  $4\pi$ . Thus  $\theta$  is  $\frac{1}{6} \times 4\pi$ , or  $\frac{2}{3}\pi$

Since  $r=2$ ,  $\frac{\theta}{r} = \frac{\frac{2}{3}\pi}{2} = \frac{\pi}{3}$ .

For radius 1, circumference is  $2\pi$ ,  $\theta$  is  $\frac{1}{6} \times 2\pi$ , or  $\frac{1}{3}\pi$ , and

$$\frac{\theta}{r} = \frac{\pi}{3} = \frac{\pi}{3}.$$

Emphasize that the results are the same, illustrating the principle discussed in the text.

2. (a)  $\frac{\pi}{2}$  (one-fourth of the circumference)
- (b)  $\frac{2}{3}\pi$  (one-third of the circumference)
- (c)  $\frac{1}{6}\pi$  (one-twelfth of the circumference)
- (d)  $\frac{5}{4}\pi$  (five-eighths of the circumference)
- (e)  $\frac{7}{4}\pi$  (seven-eighths of the circumference)
- (f)  $\pi$  (one-half of the circumference)
3. [student drawings]
4. [student drawings]
5. The measure of  $(\overrightarrow{RS}, \overrightarrow{RS})$  is 0, since this angle is congruent to the standard position zero angle. Congruent sensed angles--all in the same equivalence class--are assigned the same measure.
6. (a) No; we do not at this time consider negative arc lengths.
- (b) Yes; the "zero angle" is assigned measure 0.
- (c) The arc length  $2\pi$  corresponds to point  $(1,0)$ ; this brings us back to the zero angle, which has been assigned measure 0.
- (d) No [In Course IV, the wrapping function will assign many numbers to each sensed angles, but the principal measures will remain those numbers between 0 and  $2\pi$ ]
- (e)  $\{x: 0 \leq x < 2\pi\}$

The m function is one-to-one.

8. [student drawings] Be sure students understand that  $m^{-1}$  maps from  $\{x: 0 \leq x < 2\pi\}$  to the set of standard position sensed angles. This inverse function will play an important role in subsequent sections and in Course IV.
- (a)  $\frac{3}{2}\pi$  (The initial side is  $\overrightarrow{OX}$ , not  $\overrightarrow{OR}$ ; by way of contrast, note  $m\angle ROX = \frac{\pi}{2}$  )
- (b)  $\frac{7}{4}\pi$
- (c)  $\pi$
- (d)  $\frac{3}{4}\pi$
- (e)  $\frac{1}{8}\pi$
- (f)  $\frac{5}{8}\pi$
- (g)  $\frac{13}{8}\pi$

### 8.5 Circular Functions of Angles (2 - $2\frac{1}{2}$ days)

In this section, the SINE and COSINE functions are introduced, with the usual definitions of ordinate and abscissa, respectively, of the point where the terminal ray of a sensed angle intersects the unit circle.

Emphasize that the domain of each of these functions is the set SPSA. It is for this reason that the function names are capitalized, distinguishing them from functions of numbers to be introduced in Section 8.7 and to be denoted by the lower case names "sine" and "cosine." Thus SINE and sine are distinct functions, and the upper and lower case designations help to keep this



distinction intact.

Note that SINE (and also COSINE) is not one-to-one, since two angles may have the same SINE. This can be made clear on the overhead projector with a diagram such as that below, where

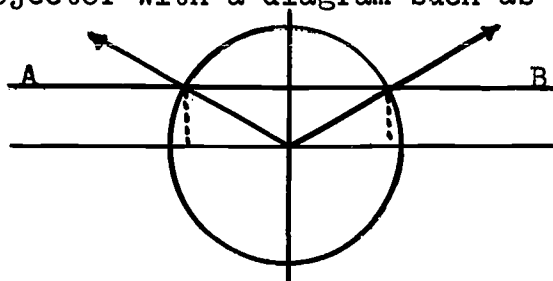

the horizontal line AB is represented by a thin stick placed on the projector so as to be parallel to the x-axis. Since this line intersects two points on the unit circle having the same ordinate, the two angles so determined have the same SINE. The same thing may be done with COSINE, this time placing the stick parallel to the y-axis.

The section includes the principle that angles have the same sense if and only if their SINES have the same sign (both positive or both negative). There is a physical way in which students may think about two angles having the same sense or opposite sense. In angle ABC below, think of transversing a path from A to B to C and back to A.

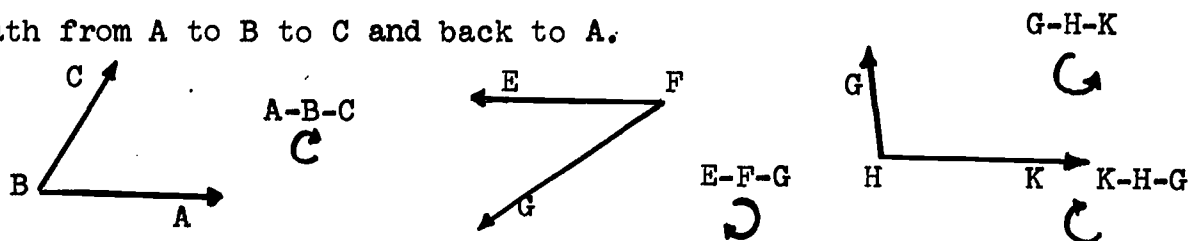

Such a path could be described as counterclockwise. Similarly the path E-F-G-E is counterclockwise. Thus the sensed angles ABC and EFG have the same sense (counterclockwise). On the other hand,  $\angle$ GHK is of opposite (clockwise) sense, since the

path G-H-K-G is physically construed as a clockwise one. (Notice, however, that  $\overrightarrow{KHG}$  does have the same sense as  $\overrightarrow{ABC}$ .) This is not intended as a definition of same sense and opposite sense, but rather as a physical aid for students in bringing some sort of meaning to the phrase "same sense."

### 8.6 Exercises

1. (a) 0 and -1  
(b) -1 and 0  
(c) 1 and 0
2. (a) 0  
(b) 1
3. (a) No point of the unit circle has y-coordinate greater than 1  
(b) No point of the unit circle has y-coordinate less than -1  
(c)  $\{x \mid -1 \leq x \leq 1\}$   
(d) No. For instance, two different angles will be assigned the number  $\frac{1}{2}$ . In fact, except for 1 and -1, every number in the range is assigned to two distinct angles.
4. (a)  $\{x \mid -1 \leq x \leq 1\}$   
(b) No
5. SINE  $\angle AOB = y$  and COSINE  $\angle AOB = x$ , where  $(x, y)$  is a point of the unit circle,  $x^2 + y^2 = 1$ . Thus. by substitution,  $[\text{SINE } (\angle AOB)]^2 + [\text{COS } (\angle AOB)]^2 = 1$
6. (a) positive  
(b) positive  
(c) negative  
(d) negative

7. (a) negative  
 (b) positive  
 (c) positive  
 (d) negative

8. (a)

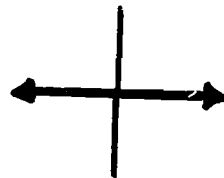

(b)

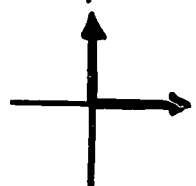

9. (a)

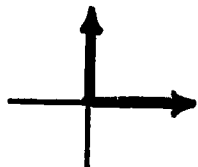

(b)

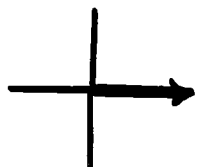

10. There are two such standard position sensed angles. They are determined by the x-axis and the line  $y=x$ .

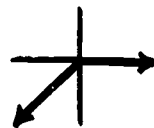
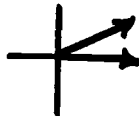

\*11. From Exercise 5,  $[\sin(\vec{\angle}AOB)]^2 + [\cos(\vec{\angle}AOB)]^2 = 1$

And if  $\sin \vec{\angle}AOB = \cos \vec{\angle}AOB$ , we have

$$[\sin(\vec{\angle}AOB)]^2 + [\sin(\vec{\angle}AOB)]^2 = 1$$

$$2[\sin(\vec{\angle}AOB)]^2 = 1$$

$$[\sin(\vec{\angle}AOB)]^2 = \frac{1}{2}$$

$$\sin(\vec{\angle}AOB) = \pm \frac{1}{\sqrt{2}} = \pm \frac{\sqrt{2}}{2}$$

The SINE function assigns  $\frac{\sqrt{2}}{2}$  to the first quadrant angle, and  $-\frac{\sqrt{2}}{2}$  to the third quadrant angle.

12.



These angles are determined by the x-axis and the line  $y = -x$ .

13. Since  $(\frac{1}{2})^2 + (\frac{1}{2}\sqrt{3})^2 = \frac{1}{4} + \frac{3}{4} = 1$ , the point  $(\frac{1}{2}, \frac{1}{2}\sqrt{3})$  satisfies the equation  $x^2 + y^2 = 1$  of the unit circle.

14. (a)

$(-\frac{1}{2}, \frac{1}{2}\sqrt{3})$

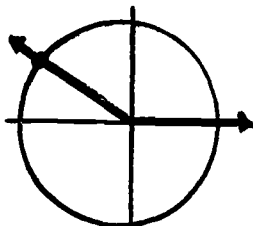

(b)

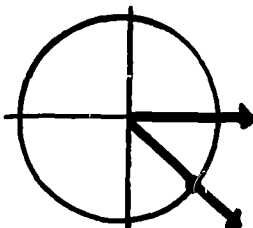

$(\frac{1}{2}, \frac{1}{2}\sqrt{3})$

(c)

$(-\frac{1}{2}, -\frac{1}{2}\sqrt{3})$

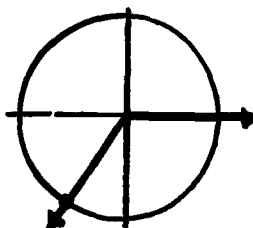

15.  $P(-a, b)$ ,  $Q(-a, -b)$ ,  $R(a, -b)$

16.

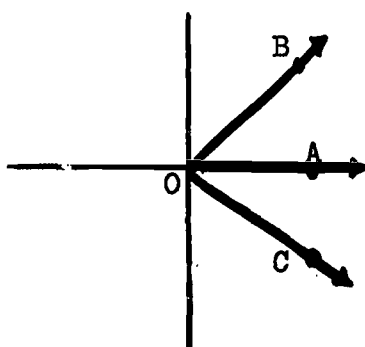

$\angle AOB$  and  $\angle AOC$  both have a positive number assigned by the COSINE function.

However, A-O-B is a "clockwise" orientation, whereas A-O-C is a "counter clockwise" orientation.

### 8.7 Circular Functions of Real Numbers ( $2 - 2\frac{1}{2}$ days)

Before this section is taught, it is might be wise to be sure that the class is clear on the SINE and COSINE functions, and on the function  $m^{-1}$ , the inverse of the  $m$  function. It may also be well to review briefly the notion of composition of functions, a concept that has been met a number of times before. Thus if  $f$  and  $g$  are functions, then the composition  $g \circ f$  is meaningful if the domain of  $g$  is a subset of the range of  $f$ .

Putting these ideas together, it is apparent that the composition  $\text{SINE} \circ m^{-1}$  is meaningful, since the domain of SINE is the set SPSA, which is also the range of  $m^{-1}$ . This composition is then a new function, denoted "sine." Its domain is  $[0, 2\pi)$  and its range is  $[-1, 1]$ . Similarly, the cosine function is defined as the composition  $\text{COSINE} \circ m^{-1}$ .

The distinguishing feature of these new functions is that they assign numbers to numbers rather than to angles as was the case with the SINE and COSINE functions. Thus students get a first notion of the idea of, say,  $\text{sine } 2$ , where 2 is a measure of something other than an angle (e.g., time).

In Course IV, with the introduction of a wrapping function, we shall be able to speak of the sine and cosine of any real number. But at the present time, with only the  $m$  function available (which deals just with principal measures) we are limited to speaking of sine (or cosine)  $x$ , where  $0 \leq x < 2\pi$ .

8.8 Exercises

1.  $(-\frac{1}{2}\sqrt{3})^2 + (\frac{1}{2})^2 = \frac{3}{4} + \frac{1}{4} = 1$

2. (a)  $\frac{5}{6}\pi$

(b)  $\angle AOB$

(c)  $\frac{1}{2}$

(d)  $\frac{1}{2}$

(e)  $-\frac{1}{2}\sqrt{3}$

(f)  $-\frac{1}{2}\sqrt{3}$

3.  $(\frac{1}{2}\sqrt{2})^2 + (-\frac{1}{2}\sqrt{2})^2 = \frac{2}{4} + \frac{2}{4} = 1$

4. (a)  $\frac{7}{4}\pi$

(b)  $\angle AOB$

(c)  $-\frac{1}{2}\sqrt{2}$

(d)  $-\frac{1}{2}\sqrt{2}$

(e)  $-\frac{1}{2}\sqrt{2}$

(f)  $\frac{1}{2}\sqrt{2}$

(g)  $\frac{1}{2}\sqrt{2}$

(h)  $\frac{1}{2}\sqrt{2}$

5. (a) -1

(b) 0

6. (a) 1

(b) -1

(c) 0

(d) 0

(e) 0

(f) 0

(g) -1

(h) 1

7. (a)  $\sin\theta > 0$ ;  $\cos\theta < 0$   
(b)  $\sin\theta < 0$ ;  $\cos\theta < 0$   
(c)  $\sin\theta > 0$ ;  $\cos\theta > 0$   
(d)  $\sin\theta < 0$ ;  $\cos\theta > 0$
8. (a) true (b) false  
(c) false (d) false  
(e) false (f) true  
(g) false (h) true  
(i) true (j) true  
(k) true (l) false
9. (a)  $\frac{1}{3}\pi$  (b)  $\frac{1}{3}\pi$   
(c)  $\frac{1}{2}\sqrt{3}$  (d)  $\frac{1}{2}\sqrt{3}$   
(e)  $\frac{1}{2}\sqrt{3}$  (f)  $\frac{1}{2}$
10. (a)  $\frac{3}{4}\pi$  (b)  $\frac{3}{4}\pi$   
(c)  $\frac{1}{2}\sqrt{2}$  (d)  $\frac{1}{2}\sqrt{2}$   
(e)  $\frac{1}{2}\sqrt{2}$  (f)  $-\frac{1}{2}\sqrt{2}$
11. (a) SPSA, the set of sensed angles in standard position  
(b) no; two angles may be assigned the same number  
(c)  $\{x | 0 \leq x < 2\pi\}$   
(d) no  
(e) SPSA  
(f) no  
(g)  $\{x | 0 \leq x < 2\pi\}$   
(h) no

### 8.9 Degree Measure, Radian Measure, and Angle Addition ( $2 - 2\frac{1}{2}$ days)

A number of principles are introduced in this section. First, the "degree protractor," familiar from earlier work, is extended to a full circular protractor so that every standard position angle may have a measurement expressed in degree units as well as in radian units. While the  $m$  function, as originally defined, assigns numbers which can be interpreted as measurements in radians but not in degrees, it is nevertheless common to see such notation as " $m(\angle AOB) = 30^\circ$ ." We avoid it as much as possible, however, saying instead such things as " $\angle AOB$  has a degree measurement of  $30^\circ$ ."

The two principles presented next (concerning the relation between the measurement of an angle and its reflection in the  $x$ -axis, and between an angle and the angle obtained by interchanging initial and terminal sides) should be clearly understood as they will be used in the development of Section 8.11. With the aid of a diagram, the two principles are very easy to understand, and the rationale in the text should make them seem reasonable to students. In terms of logical structure, they may be viewed simply as postulates.

Also to be used in Section 8.11 is the definition of angle addition, which makes up the final portion of this section. The rationale for the definition may be illustrated physically by drawing two angles, say  $\angle ABC$  and  $\angle DEF$  on the overhead projector,



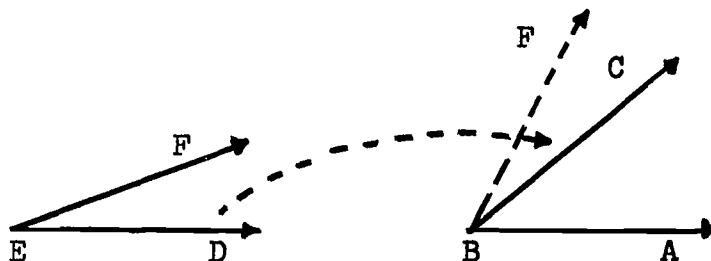

making a tracing of  $\angle DEF$ , and moving the tracing over so that  $\overline{ED}$  coincides with  $\overline{AC}$ . The angle  $\angle ABF$  so formed illustrates the sum  $\angle ABC + \angle DEF$ . Of course students should understand that the definition itself, while suggested by the picture, is independent of it.

Angle addition may serve the purpose of probing once again the fundamental concept of binary operation. Here the operation is defined on the set of sensed angles, and so we have an operational system  $(SA,+)$ . It may be of interest to investigate the properties of this system. It is associative, as a demonstration on the overhead projector may illustrate. There is an identity element; in fact, any zero angle functions as an identity. Each angle has an inverse; specifically, the inverse of  $\angle ABC$  is  $\angle CBA$ , since, by definition of angle addition,  $\angle ABC + \angle CBA = \overline{BA}$ , a zero angle. Angle addition is not commutative when one considers individual sensed angles. Thus,  $\angle ABC + \angle DEF$  is not the same as  $\angle DEF + \angle ABC$  (in the first case,  $\angle DEF$  is "moved over" to  $\angle ABC$ , while in the second  $\angle ABC$  is "moved over" to  $\angle DEF$ .) However, if one considers the operation as being defined on equivalence classes of congruent sensed angles, then the operation is commutative; in the case above, the results are not identical, but are congruent and hence in the same equivalence class. Thus, considering the operation as one of equivalence classes, the

structure is that of a commutative group.

### 8.10 Exercises

1. 0 radians
2.  $\frac{\pi}{6}$  radians
3.  $\frac{\pi}{4}$  radians
4.  $\frac{\pi}{3}$  radians
5.  $\frac{\pi}{2}$  radians
6.  $180^\circ$
7.  $120^\circ$
8.  $150^\circ$
9.  $135^\circ$
10.  $\frac{7}{4}\pi$  radians
11.  $\frac{11}{6}\pi$  radians
12.  $\frac{5}{3}\pi$  radians
13.  $\frac{3}{2}\pi$  radians
14.  $225^\circ$
15.  $240^\circ$
16.  $210^\circ$
17.  $(15 \times \frac{\pi}{180})$  radians, or  $\frac{\pi}{12}$
18.  $(\frac{360}{\pi})^\circ$
19.  $\frac{\pi}{90}$

20.  $(r \cdot \frac{180}{\pi})^\circ$
21.  $d \cdot (\frac{\pi}{180})$  radians
22. (a)  $305^\circ$  (b)  $160^\circ$   
(c)  $305^\circ$  (d)  $160^\circ$   
(e)  $55^\circ$  (f)  $200^\circ$
23. [student construction] Note that the two results here represent distinct sensed angles, and hence a lack of commutativity. However, the two sums are equivalent in the sense that they are congruent to the same standard position sensed angle.
24. (a) zero angle (b) half-turn  
(c) zero angle (d) half-turn
25.  $\angle AOB$  (note that the zero angle is an identity element for angle addition)
26. zero angle  $\angle AOB + \angle BOA = (\overline{OA}, \overline{OA})$

### 8.11 Some Special Angles ( $1\frac{1}{2}$ - 2 days)

This is one of those sections in which the unification theme is especially prominent. Essentially the purpose of the section is that of determining the SINE and COSINE of certain angles (e.g., those measuring  $30^\circ$ ,  $45^\circ$ ,  $60^\circ$ , etc.) In the development concepts from geometry (e.g., Pythagorean theorem) and transformation geometry (e.g., line reflections) are used as well as the definition of addition of sensed angles and the two principles from Section 8.9.

In the text itself, angles measuring  $60^\circ$ ,  $120^\circ$ ,  $240^\circ$ , and  $300^\circ$  are treated, with the others left for the exercises (see Exercises 1 and 2 of Section 8.12). You may wish to use these exercises as class projects, with students participating in the development. If the explanation for those angles treated in the text is understood, there should be little difficulty with the exercises.

Be sure to emphasize that it is the  $30^\circ$ ,  $45^\circ$ , and  $60^\circ$  angles which are in a sense essential here; if they are known, the others can be obtained quickly by using basic facts of transformation geometry.

### 8.12 Exercises

- |        |                        |     |                        |
|--------|------------------------|-----|------------------------|
| 1. (a) | $-\frac{1}{2}$         | (b) | $\frac{1}{2}\sqrt{3}$  |
| (c)    | $\frac{1}{2}$          | (d) | $-\frac{1}{2}\sqrt{3}$ |
| (e)    | $-\frac{1}{2}$         | (f) | $-\frac{1}{2}\sqrt{3}$ |
| 2. (a) | $-\frac{1}{2}\sqrt{2}$ | (b) | $\frac{1}{2}\sqrt{2}$  |
| (c)    | $\frac{1}{2}\sqrt{2}$  | (d) | $-\frac{1}{2}\sqrt{2}$ |
| (e)    | $-\frac{1}{2}\sqrt{2}$ | (f) | $-\frac{1}{2}\sqrt{2}$ |

3.	<u>sine</u>	<u>cosine</u>
$0^\circ$	0	1
$30^\circ$	$\frac{1}{2}$	$\frac{1}{2}\sqrt{3}$
$45^\circ$	$\frac{1}{2}\sqrt{2}$	$\frac{1}{2}\sqrt{2}$

	<u>sine</u>	<u>cosine</u>
60°	$\frac{1}{2}\sqrt{3}$	$\frac{1}{2}$
90°	1	0
120°	$\frac{1}{2}\sqrt{3}$	$-\frac{1}{2}$
135°	$\frac{1}{2}\sqrt{2}$	$-\frac{1}{2}\sqrt{2}$
150°	$\frac{1}{2}$	$-\frac{1}{2}\sqrt{3}$
180°	0	- 1
210°	$-\frac{1}{2}$	$-\frac{1}{2}\sqrt{3}$
225°	$-\frac{1}{2}\sqrt{2}$	$-\frac{1}{2}\sqrt{2}$
240°	$-\frac{1}{2}\sqrt{3}$	$-\frac{1}{2}$
270°	-1	0
300°	$-\frac{1}{2}\sqrt{3}$	$\frac{1}{2}$
315°	$-\frac{1}{2}\sqrt{2}$	$\frac{1}{2}\sqrt{2}$
330°	$-\frac{1}{2}$	$\frac{1}{2}\sqrt{3}$

4. (a)  $\frac{1}{2}\sqrt{2}$  (b)  $\frac{1}{2}\sqrt{2}$   
 (c)  $\frac{1}{2}\sqrt{2}$  (d)  $-\frac{1}{2}\sqrt{2}$   
 (e)  $-\frac{1}{2}\sqrt{2}$  (f)  $-\frac{1}{2}\sqrt{2}$   
 (g)  $-\frac{1}{2}\sqrt{2}$  (h)  $\frac{1}{2}\sqrt{2}$   
 (i)  $\frac{1}{2}$  (j)  $-\frac{1}{2}\sqrt{3}$   
 (k)  $-\frac{1}{2}$  (l)  $\frac{1}{2}\sqrt{3}$   
 (m)  $\frac{1}{2}\sqrt{3}$  (n)  $-\frac{1}{2}$   
 (o)  $-\frac{1}{2}\sqrt{3}$  (p)  $\frac{1}{2}$

5. (a)  $30^\circ, 150^\circ$  (b)  $210^\circ, 330^\circ$   
(c)  $45^\circ, 225^\circ$  (d)  $135^\circ, 315^\circ$
6. (a)  $0, \pi$  (b)  $\frac{\pi}{3}, \frac{5\pi}{3}$   
(c)  $\frac{5}{4}\pi, \frac{7}{4}\pi$  (d)  $0, \frac{\pi}{2}, \pi, \frac{3}{2}\pi$
7. (a)  $\frac{1}{2}$  (b)  $\frac{1}{2}\sqrt{3}$   
(c) 1 (d)  $\frac{1}{2}\sqrt{2}$   
(e)  $\frac{1}{2}\sqrt{2}$  (f) 1  
(g)  $\frac{1}{2}$  (h)  $\frac{1}{2}\sqrt{3}$   
(i) 1

8. Let  $m^{-1}(\theta) = \angle AOB$ .

$$\text{Then } \sin^2 \theta = (\sin \angle AOB)^2$$

$$\cos^2 \theta = (\cos \angle AOB)^2$$

From Exercise 5, Section 8.6,

$$(\sin \angle AOB)^2 + (\cos \angle AOB)^2 = 1$$

Therefore, by substitution,

$$\sin^2 \theta + \cos^2 \theta = 1$$

9. (a)  $\frac{1}{2}\sqrt{3}$   
(b)  $\frac{1}{2}$   
(c) False (note that the sine function does not possess the linearity property)  
(d) 1  
(e)  $\frac{1}{2}\sqrt{2}$   
(f)  $\frac{1}{2}$   
(g) False

10. 1.414, .707, .707

11.	1.732,	.866,	.866
12.	0	0.000	1.000
	$\frac{\pi}{6}$	.500	.866
	$\frac{\pi}{4}$	.707	.707
	$\frac{\pi}{3}$	.866	.500
	$\frac{\pi}{2}$	1.000	0.000
	$\frac{2}{3}\pi$	.866	-.500
	$\frac{3}{4}\pi$	.707	-.707
	$\frac{5}{6}\pi$	.500	-.866
	$\pi$	0.000	-1.000
	$\frac{7}{6}\pi$	-.500	-.866
	$\frac{5}{4}\pi$	-.707	-.707
	$\frac{4}{3}\pi$	-.866	-.500
	$\frac{3}{2}\pi$	-1.000	0.000
	$\frac{5}{3}\pi$	-.866	.500
	$\frac{7}{4}\pi$	-.707	.707
	$\frac{11}{6}\pi$	-.500	.866

### 8.13 Graphs of Circular Functions ( $2\frac{1}{2}$ - 3 days)

Graphs of functions should by now be a familiar concept, and it seems quite natural to investigate briefly the graphs of the sine and cosine functions. These graphs can be sketched with relative ease by using points based on the "special value"

determined in Section 8.11, together with an intuitive feeling for continuity. Thus with the points plotted in the text for  $\sin x$ , the nature of the curve becomes apparent.

The full periodic nature of the sine and cosine functions is lacking from the graphs here, since the domain at this time is restricted to  $\{x \mid 0 \leq x < 2\pi\}$ . In Course IV, with the introduction of a wrapping function, the domain is extended to the full set of real numbers, and the nature of periodicity explored.

It may be profitable to investigate the sine and cosine graphs for symmetry, a transformation geometry concept developed earlier. For example, the sine graph does not have line symmetry but it is symmetric to the point  $(\pi, 0)$ . It also has rotational symmetry about this point. Similarly the cosine graph has both symmetry and rotational symmetry about the point  $(\frac{\pi}{2}, 0)$ . (See exercises 13-16 of Section 8.14) Students may want to discuss the point that technically these symmetries do not exist unless the point  $(0, 0)$  is suppressed; this results from the fact that the number  $2\pi$  is not in the domain.

#### 8.14 Exercises

1. (a) .454 (b) .891  
(c) .643 (d) .643  
(e) .174 (f) .174  
(g) .743 (h) .743
2.  $\sin 130^\circ = \sin 50^\circ = .766$



3. (a)  $\cos 130^\circ = -\cos 50^\circ = -.643$   
 (b)  $\sin 250^\circ = -\sin 70^\circ = -.940$   
 (c)  $\cos 200^\circ = -\cos 20^\circ = -.940$   
 (d)  $\sin 290^\circ = -\sin 70^\circ = -.940$   
 (e)  $\cos 290^\circ = \cos 70^\circ = .342$   
 (f)  $\sin 179^\circ = \sin 1^\circ = .017$   
 (g)  $\cos 269^\circ = -\cos 89^\circ = -.017$   
 (h)  $\sin 359^\circ = -\sin 1^\circ = -.017$

4.

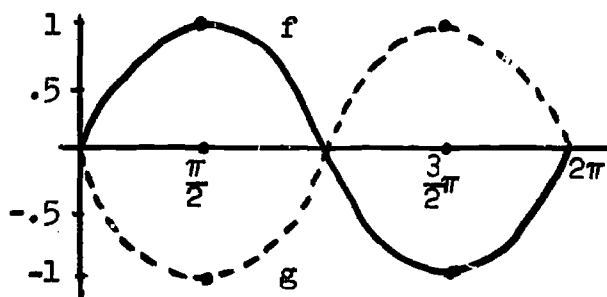

f and g are reflections of each other in the x-axis

5.

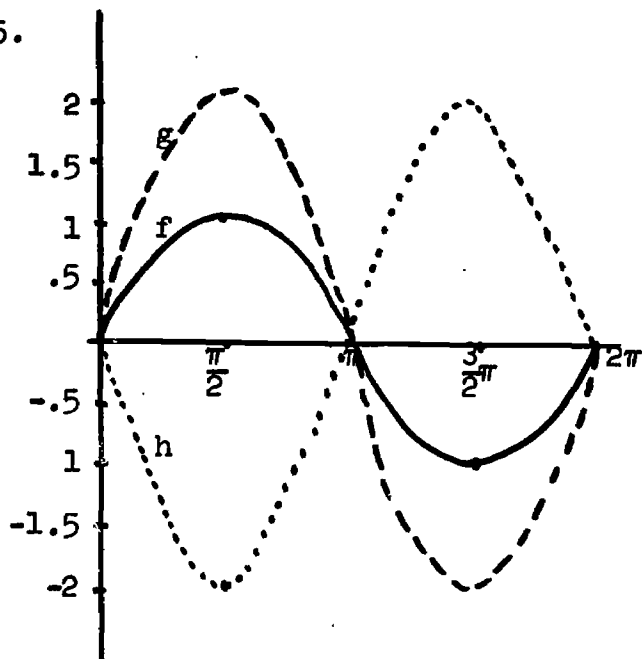

f:  $\sin x$   
 g:  $2 \sin x$   
 h:  $-2 \sin x$

Note that g and h are reflections of each other in the x-axis

(d) The range of f is  $\{y \mid -1 \leq y \leq 1\}$

The range of both g and h is  $\{y \mid -2 \leq y \leq 2\}$

6.

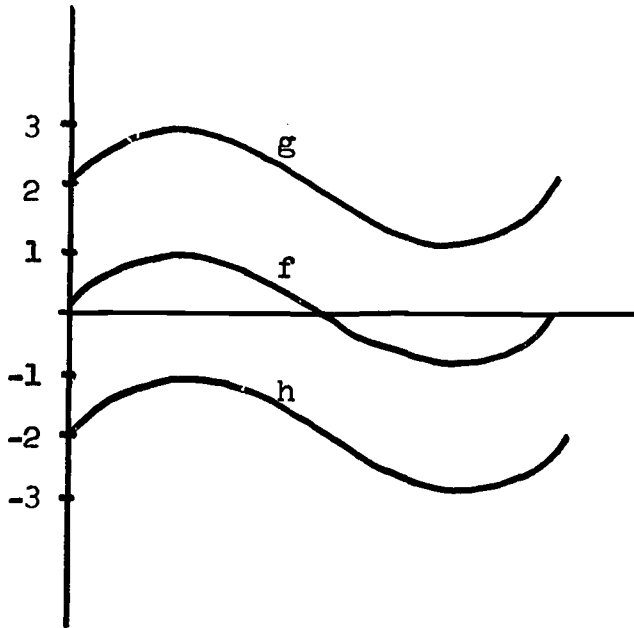

$\underline{g}$  may be obtained from  
 $\underline{h}$  by the translation  
 $(x,y) \rightarrow (x,y+4)$ ,  
 $\underline{h}$  from  $\underline{g}$  by the inverse  
translation  
 $(x,y) \rightarrow (x,y-4)$

7.

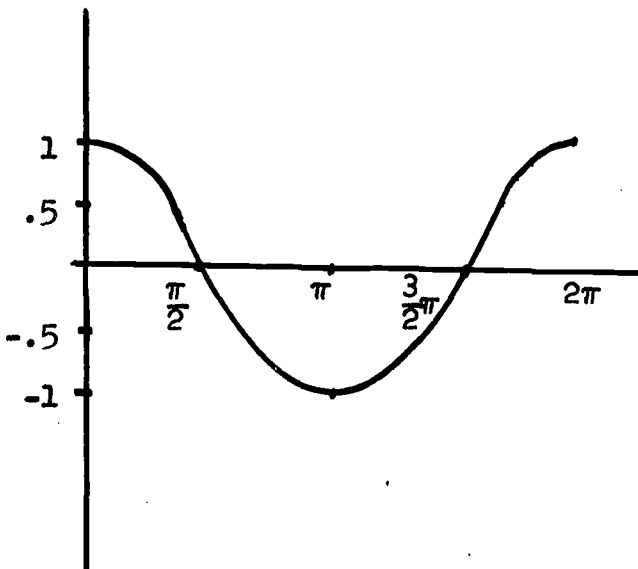

8.

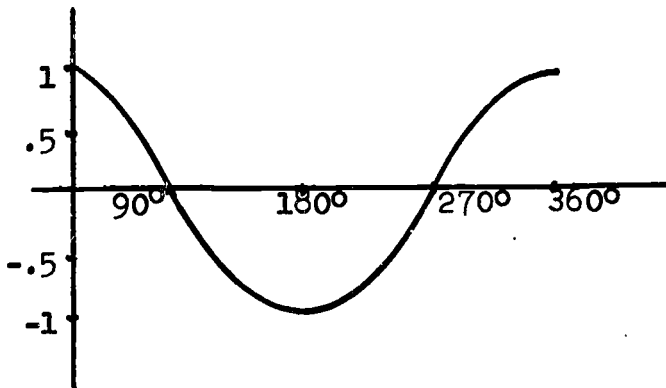

9.

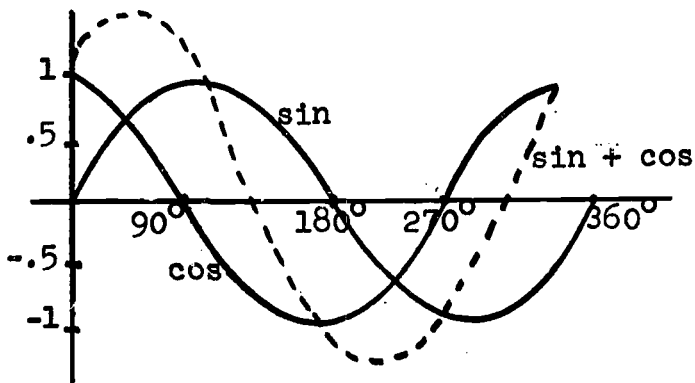

obtain the graph by  
addition of ordinates

10.

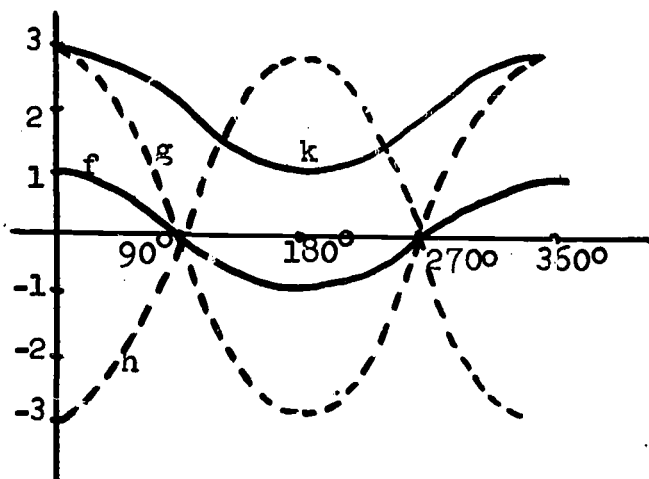

11.

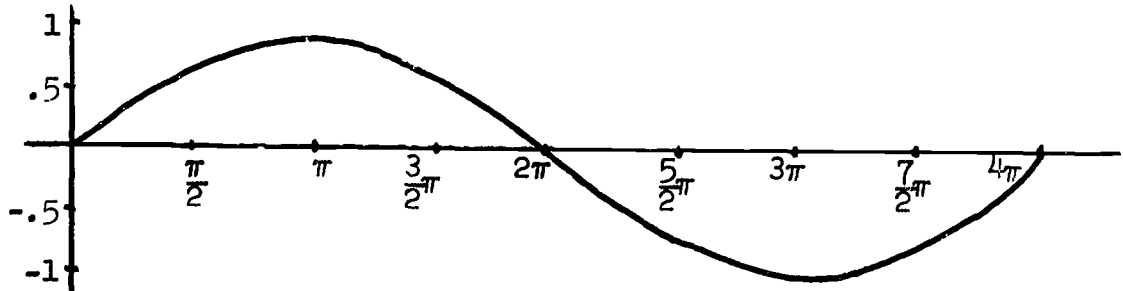

12.

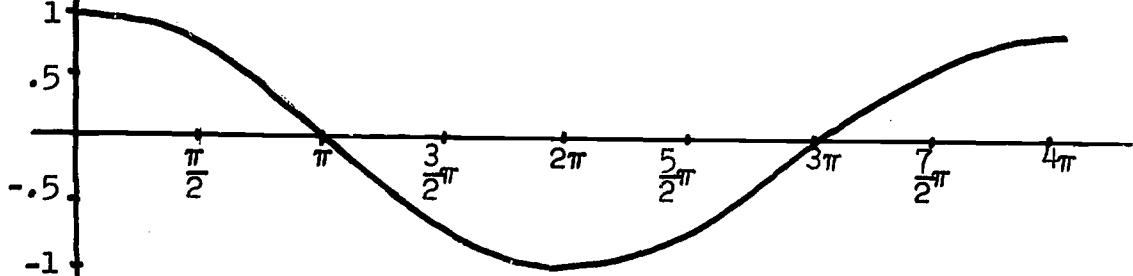

13. (a) 0

(b) The point  $(\frac{3}{4}\pi, \sin\frac{3}{4}\pi)$  and the point  $(\frac{5}{4}\pi, \sin\frac{5}{4}\pi)$  are symmetric about the point  $(\pi, 0)$ .

14. (a) 0

(b) 0

(c)  $190^\circ$

15. (a) 0

(b) The points  $(\frac{1}{3}\pi, \cos\frac{1}{3}\pi)$  and  $(\frac{2}{3}\pi, \cos\frac{2}{3}\pi)$  are symmetric with respect to the point  $(\frac{\pi}{2}, 0)$ .

16. (a) 0

(b) 0

(c)  $90^\circ + 47^\circ = 137^\circ$

8.15 Law of Cosines and Law of Sines ( $2\frac{1}{2}$  - 3 days)

The purpose of the present section is quite clearly that of developing ability to "solve triangles", once the principle concern of an elementary course in trigonometry. Instead of beginning with the solution of right triangles, we first develop the Law of Cosines and the Law of Sines; then solutions of right triangles appear simply as special cases of these (see, for instance, Exercise 11 of Section 8.16).

The derivation of the Law of Cosines involves a number of ideas encountered earlier in the program: the distance formula, the plane transformation known as a dilation, and the definition of SINE and COSINE of an angle. Thus here a new and important principle.

The derivation of the Law of Sines too calls upon some past experiences, principally those dealing with finding the area of a triangle.

Students should understand that there is not always sufficient information to solve a triangle. ("To solve" a triangle is usually taken to mean determining without ambiguity its other parts.) Exercise 14 of Section 8.16 is directed to this issue. Part (a) of that exercise is the famous "ambiguous case" of trigonometry. Thus, suppose we want to "build" a physical triangle having these parts:



There are clearly two ways to do it:

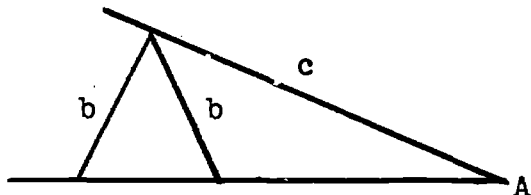

Hence, we cannot say that these three parts determine a triangle.

Let Exercise 8 in Section 8.16 come as a surprise to students; obviously the Law of Sines won't work in a "triangle" that does not exist in the first place!

### 8.16 Exercises

$$\begin{aligned} 1. \quad c^2 &= 400 + 100 - (400) (.940) \\ &= 500 - 376 \\ &= 124 \end{aligned}$$

$$\text{Thus } c = \sqrt{124} \approx 11.1$$

[The answer of course is an approximation, since  $\sqrt{124}$  has been approximated, and even .940 is an approximation of cosine  $20^\circ$ ]

$$\begin{aligned} 2. \quad c^2 &= 144 + 25 - (120) (0) \\ &= 169 - 0 \\ &= 169 \end{aligned}$$

$$c = \sqrt{169} = 13$$

[This exercise can be used to show that the Pythagorean principle is a special instance of the Law of Cosines.]

$$3. \quad (a) \quad a^2 = b^2 + c^2 - (2bc) (\cos A)$$

$$(b) \quad b^2 = a^2 + c^2 - (2ac) (\cos B)$$

4. The other two sides, as well as the angle opposite the unknown side.

5.  $a^2 = 36 + 144 - (144)(.616) \approx 91.3$

Thus  $a \approx 9.5$

6.  $b^2 = 36 + 144 - (144)(-.616)$

$\approx 268.7$

Thus  $b \approx 16.4$

[Note here that  $\cos 128^\circ = -(\cos 52^\circ)$ ]

7. (a) 0

(b) 0

(c) Pythagorean principle [See also Exercise 2, which is a particular case of this]

8.  $\frac{\sin A}{12} = \frac{\sin 60^\circ}{10}$

Thus  $\sin A \approx \frac{1}{10} \times 12 \times .866 \approx 1.0392$

But this is impossible, since no angle has a sine greater than one.

Therefore, no such triangle exists.

[Encourage doubtful students to try constructing it.]

9. approximately 4.9 and 6.6

10. First, it is a right triangle by the Pythagorean principle.

Thus, the angle opposite the 5-side is  $90^\circ$ . The other two are approximately  $53^\circ$  and  $37^\circ$ . [Either the Law of Sines or the Law of Cosines may be used here.]

11. (a)  $\frac{a}{\sin A} = \frac{c}{1}$ ; therefore  $c \cdot \sin A = a \cdot 1$

and  $\sin A = \frac{a}{c}$

(b)  $\frac{b}{\sin B} = \frac{c}{1}$ ; so,  $\sin B = \frac{b}{c}$

[Point out that these are valid in any right triangle; you may want to inject the common verbiage "side opposite over hypotenuse"]

12.  $\sin 40^\circ = \frac{a}{15}$

$a = 15(\sin 40^\circ) \approx 15 (.643) \approx 9.6$

13.  $\sin 60^\circ = \frac{b}{20}$

$b = 20(\sin 60^\circ) \approx 20 (.866) \approx 17.3$

14. (a) There are two possibilities--see discussion in preceding commentary
- (b) no
- (c) yes--use Law of Cosines
- (d) yes--use Law of Sines
- (e) yes--use Law of Cosines

8.18 Review Exercises ( $1\frac{1}{2}$  - 2 days)

1. (a)  $\overrightarrow{SR}$

(b)  $\overrightarrow{ST}$

2.  $\angle DCF$  and  $\angle FCD$

3. A sensed angle is in standard position if and only if its initial side is the "positive ray" of the x-axis.

4. (a)  $\frac{\pi}{8}$

(b)  $\frac{\pi}{4}$

5. [student drawings]

6. (a)  $\frac{1}{4}\sqrt{15}$

(b)  $\frac{1}{4}$

7. (a)  $\frac{2}{3}\sqrt{2}$  and  $-\frac{2}{3}\sqrt{2}$

(b)  $\sqrt{1-a^2}$  and  $-\sqrt{1-a^2}$

of course  $|a|$  must be less than or equal to 1.



8. (a)  $\frac{\sqrt{2}}{2}$   
(b)  $\frac{3}{4\pi}$   
(c)  $\frac{3}{4\pi}$   
(d)  $\frac{\sqrt{2}}{2}$   
(e)  $\frac{\sqrt{2}}{2}$
9. (a) The domain is  $SPSA$ , and the range is  $[-1, 1]$   
(b) The domain is  $[0, 2\pi)$  and the range is  $[-1, 1]$

10.  $\cos^2\theta = 1 - \sin^2\theta$

Since  $\sin^2\theta$  must be positive,  $\cos^2\theta$  is a number less than 1.  
Therefore,  $\cos\theta$  must be less than 1; otherwise, its square  
would exceed 1.

11. (a)  $\frac{\pi}{6}$   
(b) 180  
(c) 270  
(d) 60  
(e)  $\frac{11}{6\pi}$   
(f)  $\frac{5}{6\pi}$
12. (a)  $\frac{\sqrt{2}}{2}$   
(b)  $\frac{\sqrt{2}}{2}$   
(c)  $\frac{1}{2}\sqrt{3}$   
(d)  $-\frac{1}{2}\sqrt{3}$
13. (a) false  
(b) true  
(c) false  
(d) false

14.

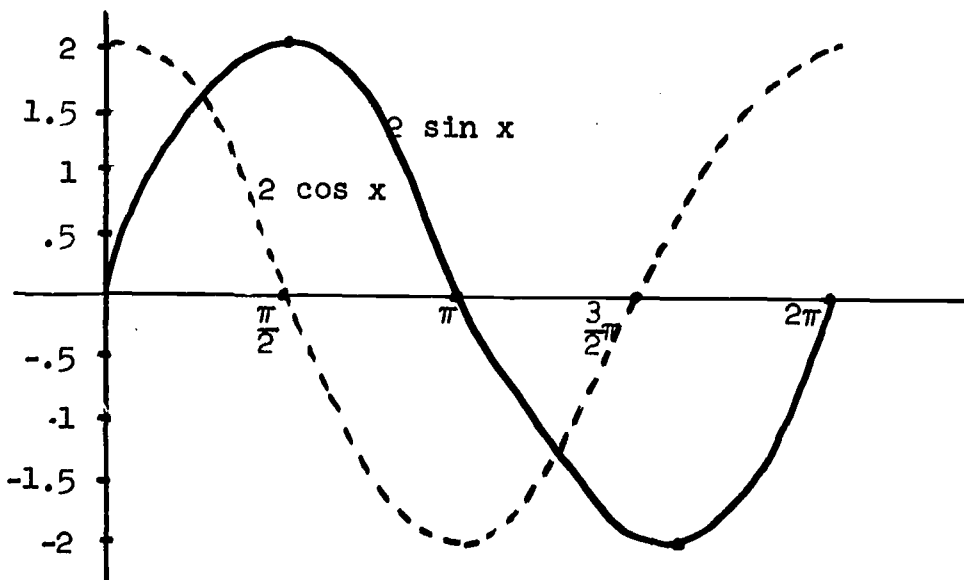

15. (a) Symmetric about the point  $(\pi, 0)$ , except that the image of  $(0, 0)$  is not contained in the graph. With  $(0, 0)$  excluded there is a point symmetry.  
(b) No
16. (a)  $70^\circ$   
(b)  $AB \approx 4.9$ ,  $AC \approx 4.5$
17.  $AB = 10$  (the triangle is isosceles)  
 $AC \approx 17.3$

17. (a)  $120^\circ$   
(b) Both sides measure approximately 5.8.

Suggested Test Items

- I. (a) A sensed angle in standard position intercepts an arc of 8 units on a circle of radius 4 units.  
What is the radian measure of the angle?
- (b) In a unit circle, a sensed angle in standard position has a radian measure of  $\frac{2\pi}{3}$ . What is the length of the arc intercepted by this angle?
- (c) A sensed angle has a measure of  $140^\circ$ . Find its radian measure.
- (d) A sensed angle has a measure of  $\frac{7\pi}{6}$  radians. Find its degree measure.
- II. (a) The terminal side of a sensed angle in standard position intersects the unit circle at  $(\frac{1}{3}, -\frac{2}{3}\sqrt{2})$ .  
If the angle is  $\angle AOB$ ,
- (1) What is Sine ( $\angle AOB$ )?
- (2) What is Cosine ( $\angle AOB$ )?
- (b) (1) If Cosine ( $\angle RST$ ) =  $\frac{3}{5}$ , what are the possible values of Sine ( $\angle RST$ )?
- (2) If Sine ( $\angle AOB$ ) =  $\frac{a}{b}$ , what are the possible values of Cosine ( $\angle AOB$ )?

III. Using the unit circle below, draw the following sensed angles in standard position, as indicated:

- (a)  $m(\angle AOB)$ ,  $\frac{3\pi}{2}$       (b)  $m(\angle AOC) = \frac{5\pi}{6}$   
 (c)  $m(\angle AOD)$ ,  $\frac{5\pi}{4}$       (d)  $m(\angle AOE) = \frac{5\pi}{3}$

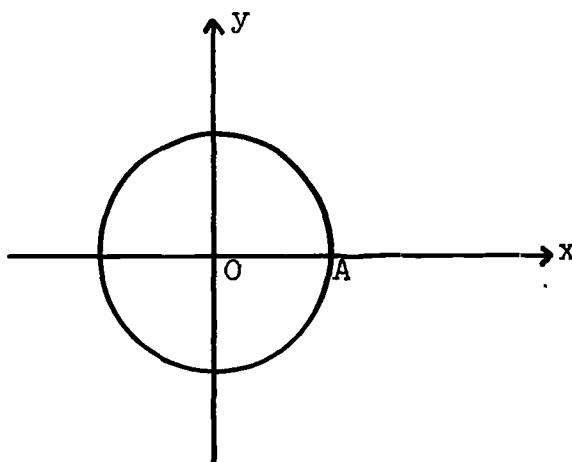

- IV. (a) What is the domain of the sine function?  
 (b) What is the domain of the Sine function?  
 (c) What is the range of the sine function?

V. Complete the following:

- (a)  $\sin 225^\circ$       (b)  $\cos 150^\circ$   
 (c)  $\cos \frac{5\pi}{3}$       (d)  $\sin 90^\circ$   
 (e)  $\cos 0$       (f)  $\cos \frac{3\pi}{2}$   
 (g)  $\sin 240^\circ$       (h)  $\sin \frac{5\pi}{6} + \sin \pi$   
 (i)  $\sin^2 30^\circ + \cos^2 30^\circ$       (j)  $\sin 60^\circ + \cos 150^\circ$

VI. Draw graphs of the following functions on the same set of axes:

- (a)  $f : x \longrightarrow \sin x \quad 0 \leq x < 2\pi$   
 (b)  $g : x \longrightarrow -\sin x \quad 0 \leq x < 2\pi$   
 (c)  $h : x \longrightarrow 2 \cos x \quad 0 \leq x < 2\pi$

- VI. In  $\triangle ABC$ ,  $AC = 4''$ ,  $AB = 5''$ , and  $\angle A = 60^\circ$ .
- (a) Find the length of  $BC$  to the nearest tenth of an inch.
- (b) By using Law of Sines find the measure of  $\angle C$  to the nearest degree.

Answers to Suggested Test Items

- I. (a) 2 radians  
(b)  $\frac{2\pi}{3}$   
(c)  $\frac{7\pi}{9}$   
(d)  $210^\circ$
- II. (a) (1)  $-\frac{2}{3}\sqrt{2}$   
(2)  $\frac{1}{3}$   
(b) (1)  $\pm \frac{4}{5}$   
(2)  $\pm \frac{\sqrt{b^2 - a^2}}{b}$
- III.

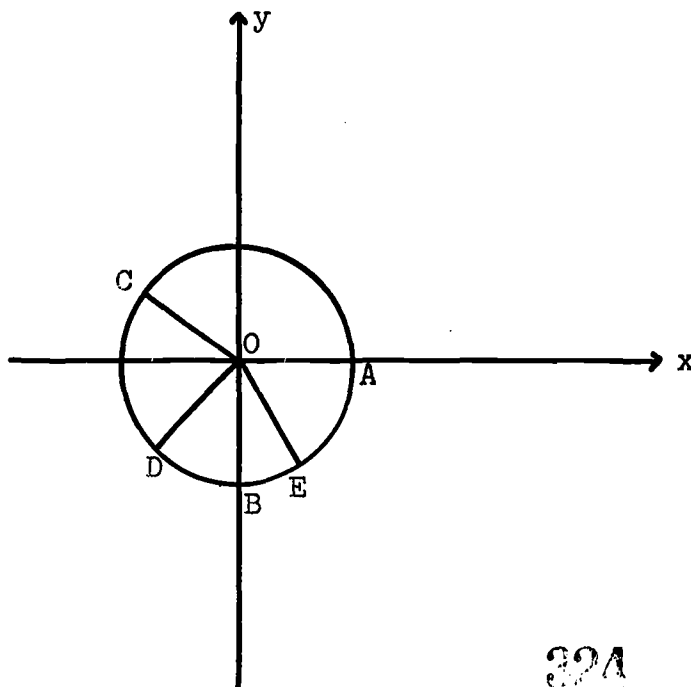

IV. (a)  $\{x : 0 \leq x < 2\pi\}$

(b) Set of sensed angles in standard position

(c)  $\{y : -1 \leq y \leq 1\}$

V. (a)  $-\frac{\sqrt{2}}{2}$  (b)  $-\frac{\sqrt{3}}{2}$  (c)  $\frac{1}{2}$

(d) 1 (e) 1 (f) 0

(g)  $-\frac{\sqrt{3}}{2}$  (h)  $\frac{1}{2}$  (i) 1

(j) 0

VI.

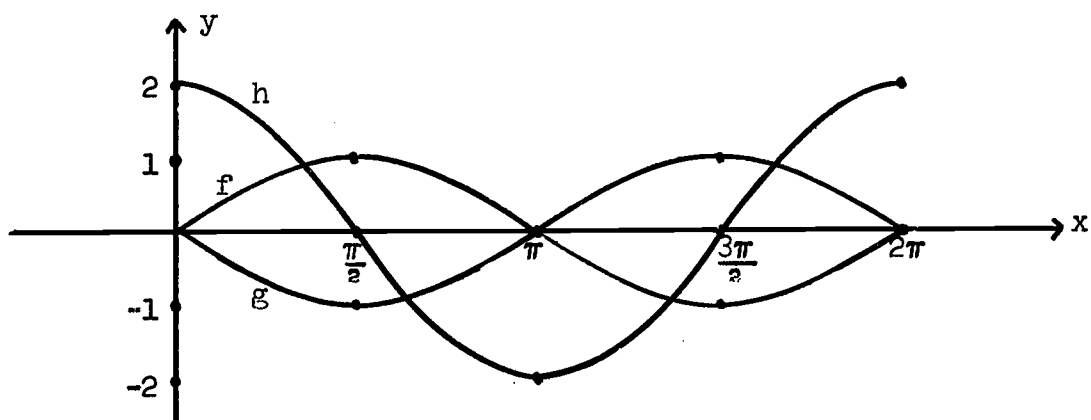

VII. (a) 4.6

(b)  $70^\circ$

## Chapter 9

### INFORMAL SPACE GEOMETRY

Time Estimate: 10 - 13 days

This chapter extends the study of geometry to three dimensional space. An introduction to incidence and parallelism of lines and planes in space is followed by a short section exposing students to deductive processes for an affine geometry in three dimensions. Following this, coordinate systems are introduced into affine 3-space using the same coordinatization axioms previously used in Course II in connection with the affine plane.

An informal discussion of perpendicularity in space follows. Rectangular coordinate systems are introduced and the distance formula for points in space is developed. The chapter ends with a short study of certain surfaces. Included are set notation descriptions of the sphere, cylinder of revolution and right circular cone.

A basic objective of the chapter is to acquaint the student with a body of information and experiences which will provide adequate background for future study of topics requiring familiarity with space geometry. Also, the chapter's content and scope reflect a desire to expose the student who might not pursue an educational program involving geometry at a higher level to as broad a sampling of space geometric notions as time will allow.

Coming as it does at the end of a course, the teacher may find that there is inadequate time available to cover all the material of the chapter. In that event, it is recommended that priority be given to Sections 1-5 on lines and planes in space, and Sections 10-15 on perpendicularity and rectangular coordinate systems.

### 9.2 Planes in Space (1 day)

A set of activities are suggested leading to a number of "Observations" which are not formalized to the status of axioms in the section. The students are expected to accept these observations as statements concerning physical reality, conforming with their life-experiences.

### 9.3 Solutions to Exercises

1. (a) infinite number (b) infinite number (c) infinite number
2. one
3. one
4. one
5. (a) no (b) three (c) no; none; six
6. (a) yes (b) one or four; yes
7. (a) none (b) four (c) infinite number
8. no
9. It depends on Observation 2 and the fact that two given points can lie in infinitely many planes.
10. Have fun arguing with your class on this.



11. (a) a line                      (b) yes, Observation 1  
12. (a) yes                      (b) no                      (c) no  
    (d) no                      (e) yes

#### 9.4 Parallel Lines and Parallel Planes in Space (1 day)

This section includes intuitive exploration designed to make the standard definitions of parallelism plausible and leading also to Observation 5 which is the generalization of the parallel postulate to space. In the activities it is very important to stress the fact that physical models are only suggestive of geometric properties. To avoid limiting the applicability of geometric results we should obtain abstract idealizations of limited physical objects.

#### 9.5 Solutions to Exercises

1. given in text
2. false
3. true
4. false
5. false
6. false
7. true
8. true
9. false
10. true

11. true
12. true
13. false

### 9.6 Deductive Processes in Affine Space Geometry ( $1\frac{1}{2}$ -2 days)

No attempt is made in this section to develop a formal synthetic geometry paralleling the approach for plane geometry in Course II, Chapter 3.

Accepting the five Observations (axioms), the student observes how certain statements (theorems) can be deduced by use of the Observations. There is danger, of course, that the students will confuse "truth" with validity. The teacher should take pains to emphasize that we accept the Observations as being "true"; the statements are then necessary consequences.

The proofs in the first two Examples are rather informal. For the third, an indirect approach is outlined and the student is led to the point where he should be able to complete the proof himself.

Because of limited experience with writing proofs, it might be unwise to assign more than a few of the exercises of Section 9.7 immediately. A better procedure might be to proceed to subsequent sections after covering the first few exercises, the remainder being assigned one or two at a time as subsequent sections of the chapter are studied.

### 9.7 Solution to Exercises

1. Suppose  $m$  and  $n$  are a distinct pair of parallel lines. There is a plane  $\pi_1$  which contains both  $m$  and  $n$  (see Section 9.4). Suppose  $\pi_2 \neq \pi_1$  contains  $m$  and  $n$ . Let  $P, Q \in m$  and let  $R \in n$ .  $P, Q,$  and  $R \in \pi_1$ , since  $m, n \in \pi_1$ . If  $m, n$  also  $\in \pi_2$ , then  $P, Q$  and  $R$  also  $\in \pi_2$ . But this contradicts Observation 2 which states that three non-collinear points lie in exactly one plane. Consequently  $m$  and  $n$  are contained in exactly one plane.
2. Let  $\pi_1$  and  $\pi_2$  be two distinct parallel planes and let  $\pi_3$  intersect  $\pi_1$ . Suppose  $m$  is the intersection of  $\pi_1$  and  $\pi_3$ . (we assume that  $\pi_3$  is distinct from  $\pi_1$  and  $\pi_2$ .) If we claim that  $\pi_3$  does not intersect  $\pi_2$ , then it must be parallel to it. If  $A$  is a point in  $m$ , then  $\pi_1$  and  $\pi_3$  are two distinct planes containing point  $A$  in space which are both parallel to  $\pi_2$ . This violates Observation 5. Consequently  $\pi_3$  must intersect  $\pi_2$  as well as  $\pi_1$ .
3. Let  $\pi_1$  and  $\pi_2$  be parallel planes and let  $\pi_3$  intersect both  $\pi_1$  and  $\pi_2$ . Also, let the intersection be  $m = \pi_3 \cap \pi_1$  and  $n = \pi_3 \cap \pi_2$ . Are  $m$  and  $n$   $\parallel$ ? Suppose they are not. Then they intersect at some point  $P$ .  $P \in m \longrightarrow P \in \pi_1$ ;  $P \in n \longrightarrow P \in \pi_2$ .  $\therefore P$  is a point of intersection of  $\pi_1$  and  $\pi_2$ . But this violates our given information that  $\pi_2$  and  $\pi_1$  are parallel and therefore have no intersection. Consequently  $m \parallel n$ .

4. Let  $m$  and  $n$  be two parallel lines (suppose them to be distinct), and let  $A$  be the intersection of  $m$  with plane  $\pi$ . Will  $\pi$  intersect  $n$  also? Suppose it does not, that is, that  $n \parallel \pi$ . According to Example 3, parallel lines  $m$  and  $n$  are contained in exactly one plane  $\pi'$ .  $\pi'$  will intersect  $\pi$  in some line  $p$  which contains  $A$ .  $p$  and  $n$  are distinct coplanar lines which are not parallel, hence, have an intersection point  $B$ . But  $B$  must be in both  $\pi$  and  $\pi'$  since every point of  $p$  lies in  $\pi$  and  $\pi'$ . So  $\pi$  intersects  $n$  at  $B$ , and our assumption that  $n \parallel \pi$  was incorrect. Therefore,  $\pi$  intersects  $n$ .
5. Let  $\pi_1$  and  $\pi_2$  be two parallel planes, and let  $m \cap \pi_1 = A$ . Will  $m$  intersect  $\pi_2$  in a point also? (Assume  $\pi_1$  and  $\pi_2$  to be distinct planes.) Suppose  $m \parallel \pi_2$ . Let  $n$  be an arbitrary line in  $\pi_1$  which includes  $A$ . By Example 2,  $m$  and  $n$  are contained in a unique plane  $\pi_3$ . In Exercise 3 above we proved that if two parallel planes are intersected by a third plane, the intersection lines are parallel. Suppose  $p$  is the intersection of  $\pi_3$  and  $\pi_2$ . Then  $p \parallel n$ . Now,  $p$  and  $n$  are both in  $\pi_3$ . If they are parallel then we have  $m$  and  $n$  in  $\pi_3$ . If they are not parallel then we have  $m$  and  $n$  in  $\pi_3$  containing  $A \notin p$  and parallel to  $p$ . This violates the parallel postulate. Therefore,  $m$  intersects  $\pi_2$ .
6. Let  $\ell$  and  $m$  be parallel, and let  $\pi$  contain  $\ell$ . Is  $m \parallel \pi$ ? Suppose not. Then  $m \cap \pi = A$ . Let  $\pi'$  be the unique plane

containing  $l$  and  $m$  (Example 3).  $A \in m$  implies that  $A$  is in  $\pi'$ , and therefore  $A$  is in both planes. But the only points in the intersection of both planes are in the line  $l$ . Therefore  $A$  is an intersection point of  $l$  and  $m$ . This violates our given information that  $l$  and  $m$  are parallel. Consequently  $m \parallel \pi$ .

7. (Reflexivity). Every plane is parallel to itself by definition.

(Symmetry). If  $\pi_1 \parallel \pi_2$ , then  $\pi_2 \parallel \pi_1$  by definition of parallel planes.

(Transitivity). Let  $\pi_1 \parallel \pi_2$  and  $\pi_2 \parallel \pi_3$ . We must prove that  $\pi_1 \parallel \pi_3$ . Suppose  $\pi_1 \not\parallel \pi_3$ . Then  $\pi_1$  and  $\pi_3$  are distinct intersecting planes. Since  $\pi_1 \parallel \pi_2$ , and  $\pi_3$  intersects  $\pi_1$ , then  $\pi_3$  must intersect  $\pi_2$ , contradicting the fact that  $\pi_2 \parallel \pi_3$ , therefore  $\pi_1 \parallel \pi_3$ .

\*8. (Reflexivity). Every line is parallel to itself by definition.

(Symmetry). If  $l \parallel m$ , then  $m \parallel l$  by definition of parallel lines.

(c) (Transitivity): Let  $l \parallel m$  and  $m \parallel n$ .

We must now prove that  $l \parallel n$ .

(1) If  $l = m$  or  $m = n$ , there is nothing further to prove. Hence we may assume that  $l$ ,  $m$  and  $n$  are distinct lines in which case they are disjoint.

(Why?)

- (2) There is a plane  $\pi_1$  containing  $l$  and  $m$  and a plane  $\pi_2$  containing  $m$  and  $n$ . (Example 3.)
- (3) If  $\pi_1 = \pi_2$  then  $l$ ,  $m$  and  $n$  are coplanar in which case the theorem follows from transitivity of parallelism in a plane (see Course II, Chapter 3, Theorem 15). Hence take  $\pi_1 \neq \pi_2$ . If  $P$  is any point in line  $n$ , then there is a plane  $\pi_3$  that contains line  $l$  and point  $P$ .

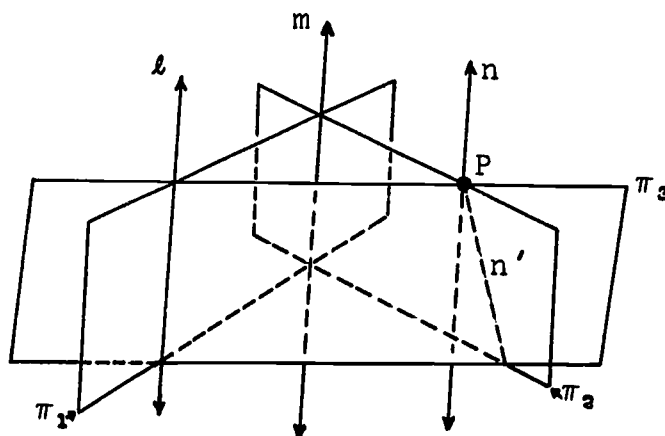

- (4)  $\pi_1$ ,  $\pi_2$  and  $\pi_3$  are distinct planes.
- (5) Since  $\pi_2$  and  $\pi_3$  are distinct planes both containing  $P$ , these two planes must intersect in some line  $n'$  containing  $P$ .
- (6) The points common to  $\pi_1$  and  $\pi_3$  are all in line  $l$ ; the points common to  $\pi_1$  and  $\pi_2$  are all in line  $m$ . Therefore line  $n'$  cannot intersect plane  $\pi_1$ .
- (7) Therefore  $l \parallel n'$  and  $m \parallel n'$ .
- (8) Since  $m \parallel n$  and  $m \parallel n'$ ,  $n = n'$ . But these were distinct lines!
- (9) Consequently  $l \parallel n$ .

## 9.8 Coordinate Systems in 3-Space (1 - $1\frac{1}{2}$ days)

This section extends the coordinatization of the plane begun in Course II to all of three-space. The procedure is the natural generalization of the one used in that chapter. It depends on the fact that if three planes (the  $xy$ ,  $xz$ , and  $yz$ -planes) meet in a single point, then any triple of planes parallel respectively to the three given planes also intersect in a single point.

Since 3-dimensional diagrams are not easy to sketch "off-the cuff" it might be desirable to prepare some of the diagrams in advance on transparencies suitable for use with an overhead projector.

## 9.9 Solutions to Exercises

1. (a) If  $P$  is any point on the  $y$ -axis, then the plane  $\pi_1$  (which contains  $P$  and is parallel to the  $yz$ -coordinate plane) is identical with the  $yz$ -coordinate plane because point  $P$  is contained in this plane. Since this plane intersects the  $x$ -axis at  $O$ , the  $x$ -coordinate of  $P$  is  $0$ .  $P$  is also in  $\pi_2$ , which intersects the  $z$ -axis at  $O$ . Consequently its  $z$ -coordinate is  $0$ . Hence the  $y$ -axis contains points whose  $x$  and  $z$ -coordinates are both  $0$ .
- (b)  $\{P(x, y, z): x = 0, y = 0\}$ .

To assign a  $z$ -coordinate to a point  $P$ , we use

Observation 5 to obtain a unique plane  $\pi_3$  which contains P and is parallel to the xy-plane. This plane  $\pi_3$  must intersect the z-axis in a unique point Z. The point Z thus determined has a unique  $(0, J)$  line coordinate which we assign as the "z-coordinate of point P."

3. (a) All points on the positive y-axis.

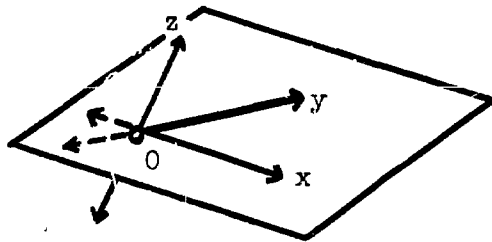

- (b) All points on the negative x-axis (ray not including its endpoint).

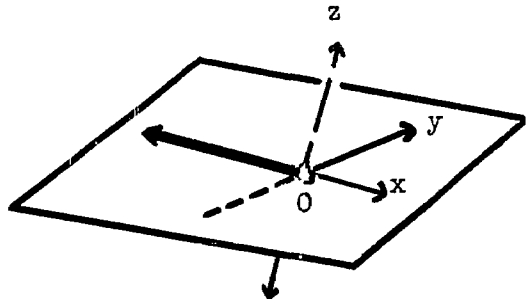

- (c) All points on the positive z-axis together with the origin (ray including its endpoint).

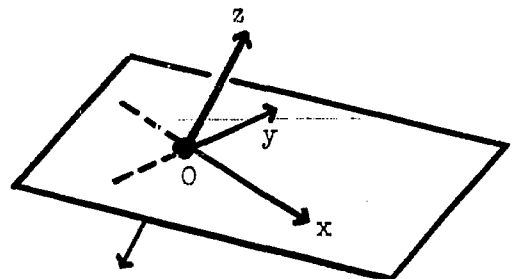

- (d) A segment consisting of all points on the x-axis between the origin O, and the point P(4,0,0). (The endpoints O and P are not included.)

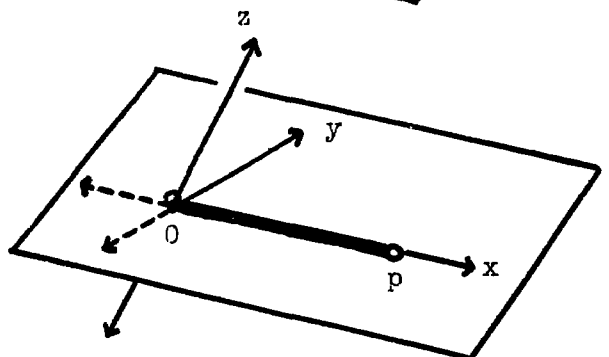



- (e) All points in the  $xz$ -coordinate plane. (Indicated by shading in diagram).

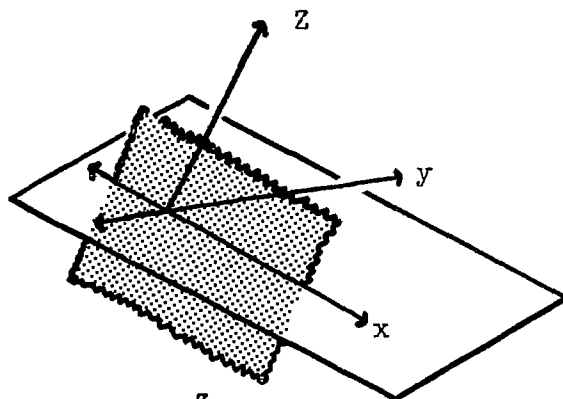

- (f) All points in space which are on the "positive side" of the  $xz$ -coordinate plane.

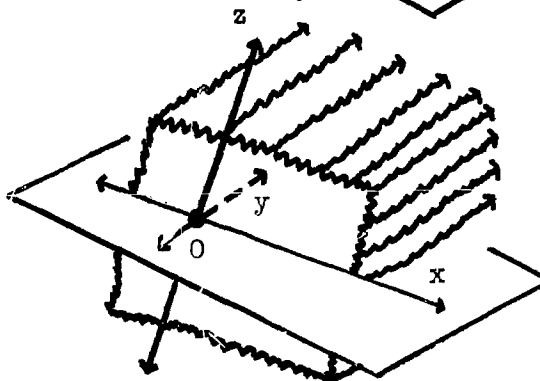

- (g) All points in space which are on the "negative side" of the  $xz$ -coordinate plane.

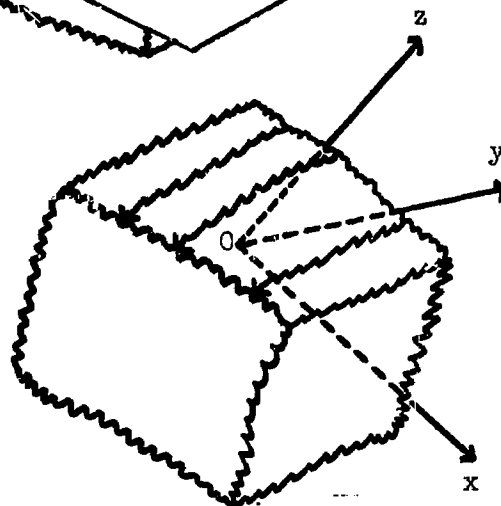

- (h) All points in a plane parallel to the  $xz$ -plane containing the point  $Y(0, 5, 0)$  (Shaded)

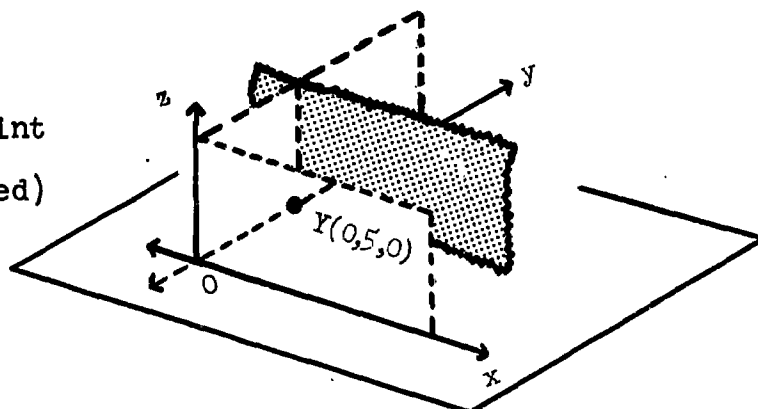

- (i) All points between the  $xz$ -coordinate plane and the plane indicated in the diagram

4. (a)  $\{P(x, y, z): x = 0\}$   
 (b)  $\{P(x, y, z): x = 0, y = 0, z < 0\}$   
 (c)  $\{P(x, y, z): z = 5\}$   
 (d)  $\{P(x, y, z): 0 < z < 5\}$
5. (a)  $\{P(x, y, z): z = 4\}$   
 (b)  $\{P(x, y, z): x = 2\}$   
 (c)  $\{P(x, y, z): y = 0\}$
6. (a)

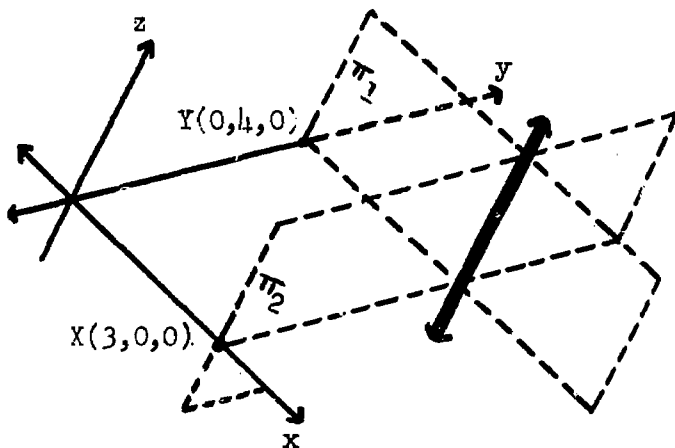

The line of intersection of two planes:  $\pi_1$ , parallel to the  $xz$  coordinate plane, and  $\pi_2$ , parallel to  $yz$  coordinate plane.

(b)

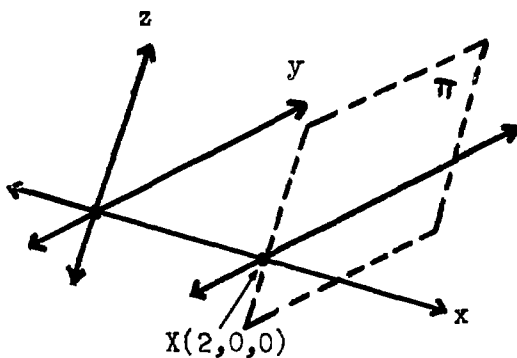

The line of intersection of the  $xy$ -coordinate plane with a plane  $\pi$  parallel to the  $yz$ -coordinate plane. (Note the line is parallel to the  $y$ -axis.)

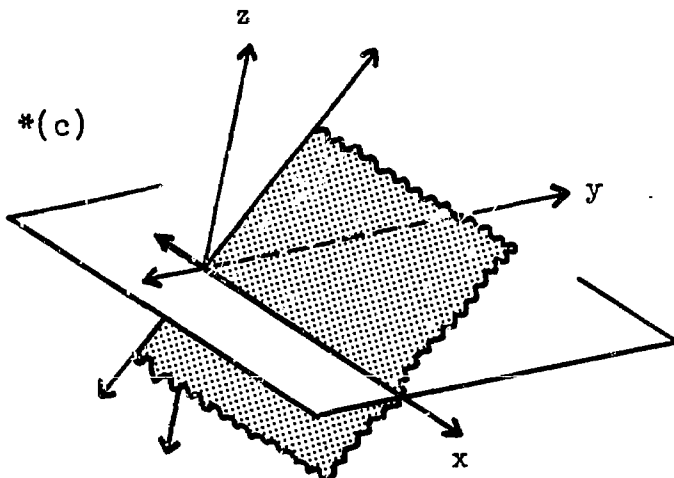

A plane containing the x-axis and intersecting the yz-coordinate plane along a line where  $y = z$ .

7. (a)  $\{P(x, y, z): x = 0, y = 2\}$   
 (b)  $\{P(x, y, z): x = 2, y = 3\}$   
 (c)  $\{P(x, y, z): y = 2x, z = 0\}$   
 \*(d)  $\{P(x, y, z): y = 3x\}$

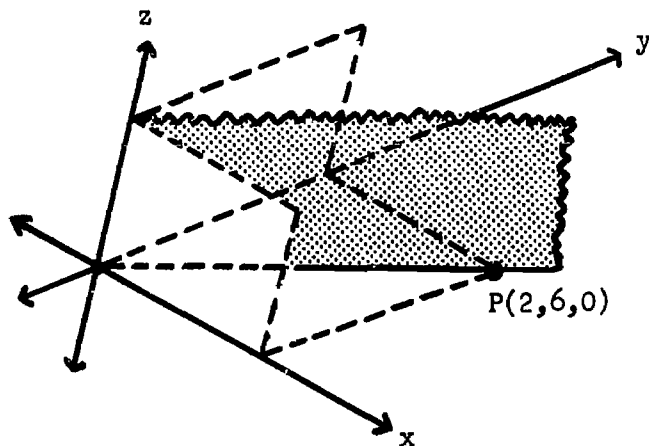

8.

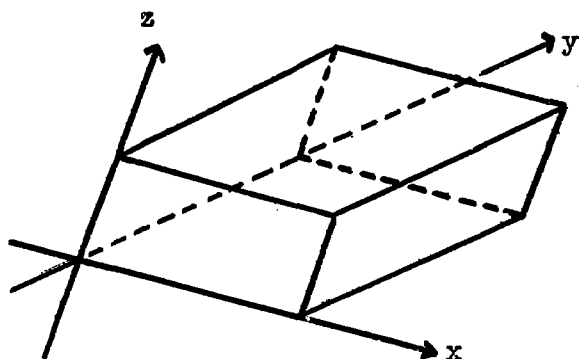

This set consists of all points within as well as on the surface of a parallelepiped whose edges are 4, 3, and 2 units.

9. (a)  $O = (0, 0, 0)$ ,  $A = (1, 0, 0)$ ,  $B = (0, 1, 0)$ ,  $C = (0, 0, 1)$   
 (b)  $L = (\frac{1}{2}, 0, 0)$ ,  $M = (0, \frac{1}{2}, 0)$ ,  $N = (0, 0, \frac{1}{2})$   
 $P = (\frac{1}{2}, \frac{1}{2}, 0)$ ,  $Q = (\frac{1}{2}, 0, \frac{1}{2})$ ,  $R = (0, \frac{1}{2}, \frac{1}{2})$

9.10 Perpendicularity of Lines and Planes in Space (1 day)

Four major points should be made in this section. First, a line is perpendicular to a plane if it is perpendicular to every line in the plane through the point of intersection of the original line and the plane, and the lesser sufficient condition that perpendicularity to two lines guarantees perpendicularity to the plane. Second, there is a unique perpendicular to a plane at a point on the plane and from a point not on the plane, but in space there is not a unique perpendicular line to a given line at a point on that line. Third, two intersecting planes are perpendicular if and only if there is a line in each plane perpendicular to their line of intersection and these two lines are perpendicular. Fourth, if a line is perpendicular to a plane, then any plane containing that line is perpendicular to the given plane.

9.11 Solution to Exercises

1. Yes, no, no, 2
2. The lines are parallel to each other
3. The perpendicular from a point to a plane is the shortest distance between these two point sets.
4. false
5. true
6. true
7. true

- 8. false
- 9. false

9.12 Rectangular Coordinate Systems in Space (1 day)

The classroom space is utilized as a simple example of a rectangular coordinate system in space. The mid-point formula for 3-space is introduced by an example and as a natural extension of the corresponding formula in two dimensions.

9.13 Solutions to Exercises

- 1. (a) (36,13,5)      (b) (18,26,5)      (c) (18,0,5)  
    (d) (36,0,10)      (e) (36,0,0)      (f)  $(9,6\frac{1}{2},2\frac{1}{2})$
- 2. Answers will vary.
- 3. (a) (6,8,9)      (b) (-6,8,9)      (c) (-1,-2,6)      (d) (6,2,-9)
- 4. (a) (2,3,-2)      (b) (-3,0,-9)      (c) (13,0,0)      (d) (16,-6,10)
- 5. (a) (-2,-3,2)      (b) (-7,-6,-5)      (c) (9,4,4)      (d) (12,-12,14)
- 6. Yes,  $(x+a, y+b, z+c) = (x+a', y+b', z+c')$  implies  $x+a = x+a'$  which implies  $a = a'$ , etc.
- 7. Yes. The pre-image of  $(x,y,z)$  is  $(x-a, y-b, z-c)$ .

9.14 Distance in Space (1 -  $1\frac{1}{2}$  days)

It should be stressed that this section pre-supposes the adoption of a rectangular coordinate system for 3-space, because a proof of the distance formula is based on the Pythagorean

property for right triangles. In a general affine coordinate system, the triangle OBC in Figure 9.33 would not be a right triangle and the length of  $\overline{OB}$  would not be  $\sqrt{(18)^2 + (13)^2}$  as indicated in the text.

### 9.15 Solutions to Exercises

1. (a) 13 (b) 26, (c) 13 (d) 13
2. (a)  $OP = 26, (3, 4, 12), 13$   
(b)  $OP = 13, (-\frac{3}{2}, -2, -6), 6\frac{1}{2}$   
(c)  $OP = \sqrt{50}, (\frac{3}{2}, 2, 2\frac{1}{2}), \frac{1}{2}\sqrt{50}$   
(d)  $OP = 2\sqrt{50}, (3, 4, 5), \sqrt{50}$
3. Should confirm.
4. (a) 3 (b) 6 (c) 1 (d)  $\sqrt{97}$
5. (a)  $(5, -2, 4)$   
(b)  $AM = 3, MB = 3, AB = 6$   
(c) Since  $AM + MB = AB$ , the point M must lie on segment  $\overline{AB}$  and since  $AM = MB$  this point must be the midpoint of segment  $\overline{AB}$ .
6. Midpoint of side  $\overline{AB}$  is  $M(-1, 0, 4)$   
Length of median:  $CM = \sqrt{(1-(-1))^2 + (2-0)^2 + (-4-2)^2}$   
 $= \sqrt{2^2 + 2^2 + 6^2}$   
 $= \sqrt{42}$

### 9.16 Surfaces in Space ( $1\frac{1}{2}$ - 2 days)

This section presents some familiar surfaces with precise

descriptions in set theoretic terms. Using rectangular coordinates, set expressions are derived for the sphere, right circular cylinder and cone of revolution. For simplicity, the center of the sphere is located at the origin and the axes of the cylinder and cone coincide with coordinate axes. If time permits, set descriptions of these surfaces with other center and axis locations can be investigated with the aid of translations, - possibly even rotations. (See Exercise 8 in the chapter summary.)

The right circular cone displayed in coordinatized space has an element angle of 45 degrees. Since the tangent function is not introduced until Course IV, the general description, with cone angle  $\alpha$ , of a cone oriented as in the text example might be inappropriate at this time. It is  $\{p(x,y,z): x^2 + y^2 = \frac{z^2}{\tan^2 \alpha}\}$ . However, a description in terms of sine and cosine might be derived by students in a "project" setting.

### 9.17 Solutions to Exercises

1. circle
2. circles of varying diameter with centers lying on an axis of the sphere.
3. circles of varying diameter, the longest being that determined by the plane that also passes through the center of the sphere.

4. (a)

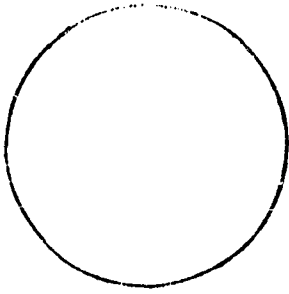

(b)

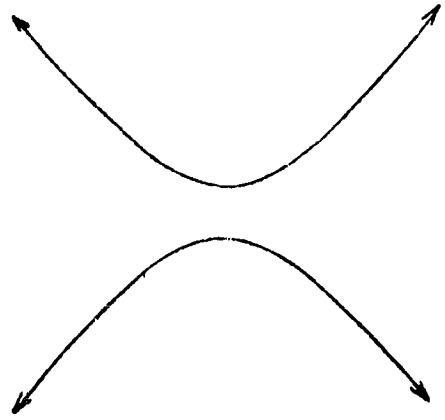

(c)

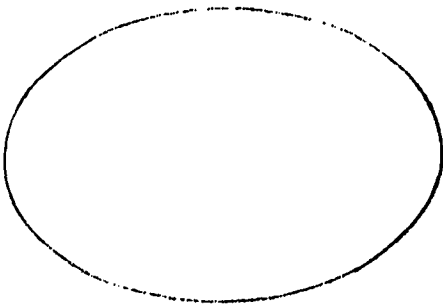

OR



5. (a)

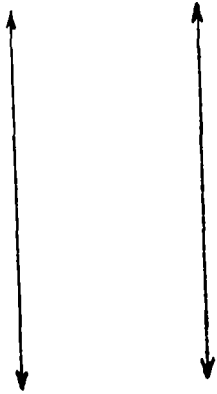

(b)

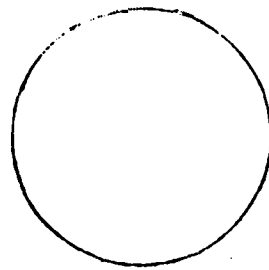

(c)

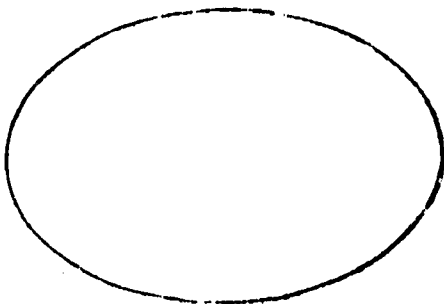



6. It is a plane except that one line is missing, the line through the vertex of the cone and parallel to the generating curve.

7. It is a plane.

8. (a) a sphere centered at the origin with radius 1

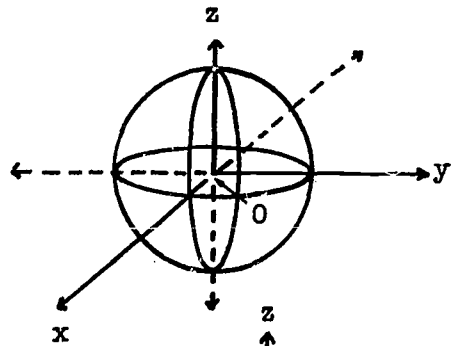

(b) a sphere centered at the origin with radius  $\sqrt{2}$

See above diagram

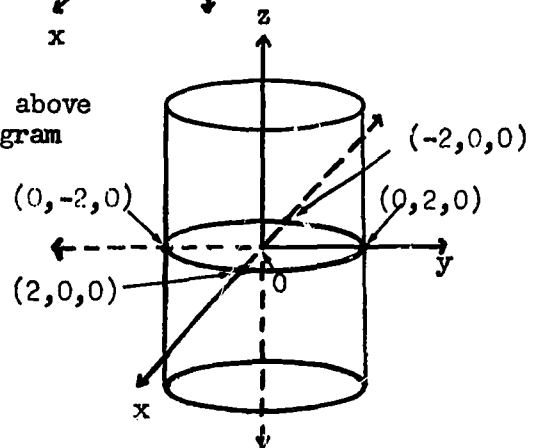

(c) a right circular cylinder, axis the z-axis, and with radius 2

(d) a right circular cylinder axis the x-axis, and with radius 1

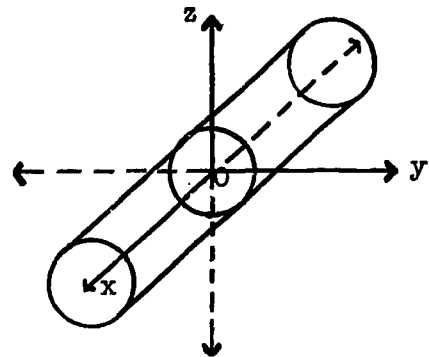

(e) a right circular cylinder, axis the y-axis, and with radius 3.

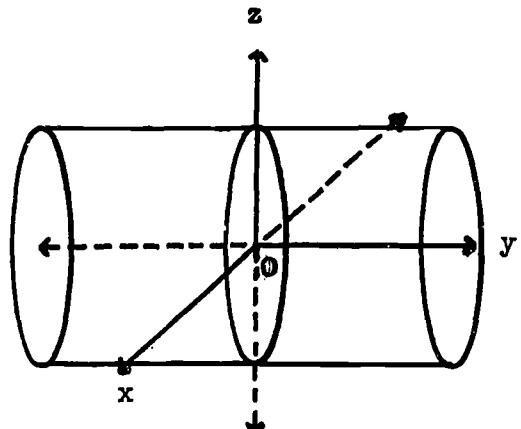

- (f) a right circular cone,  
axis the  $y$ -axis, vertex  
at the origin, and  $\alpha = 45$

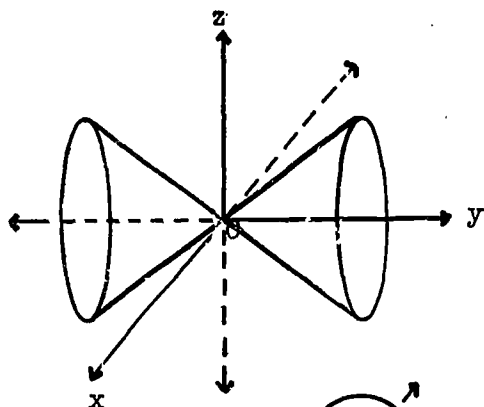

- (g) a right circular cone,  
axis the  $x$ -axis, vertex  
at the origin, and  $\alpha = 45$

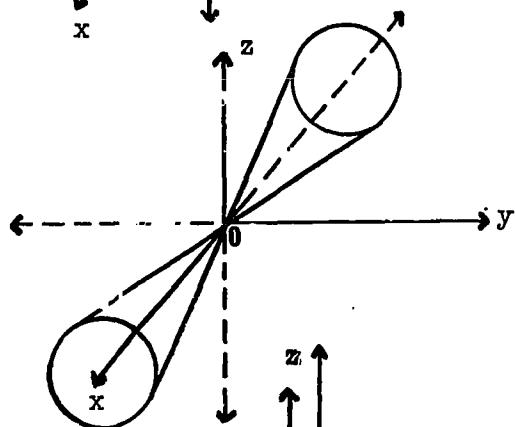

9. (a) a line containing the point  
 $(1,1,0)$  and parallel to the  
 $z$ -axis intersects the sphere  
in the points  $(1,1,\sqrt{2})$  and  
 $(1,1,-\sqrt{2})$

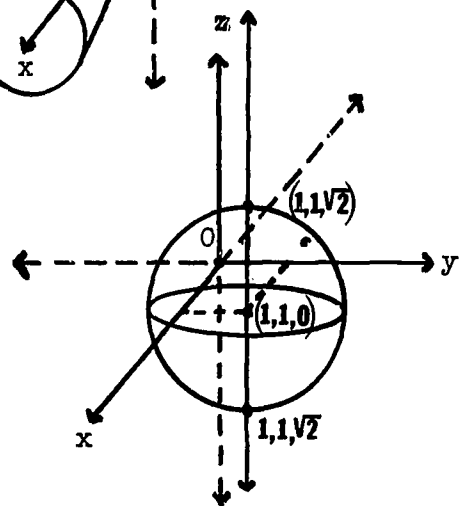

- (b) a plane containing the point  
 $(0,0,1)$  and parallel to the  
 $xy$ -coordinate plane intersects  
the sphere in a circle centered  
at  $(0,0,1)$  and with radius  $\sqrt{3}$ .  
The plane of the circle is  
parallel to the  $xy$ -coordinate  
plane.

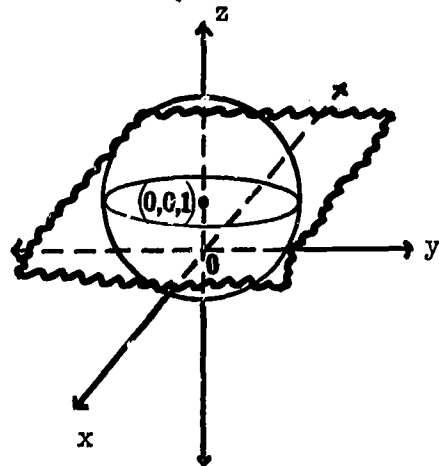

(c) A right circular cylinder with axis the  $z$ -axis and with radius 2 intersects the sphere in a circle in the  $xy$ -plane. The center of the circle is at the origin and the radius is 2.

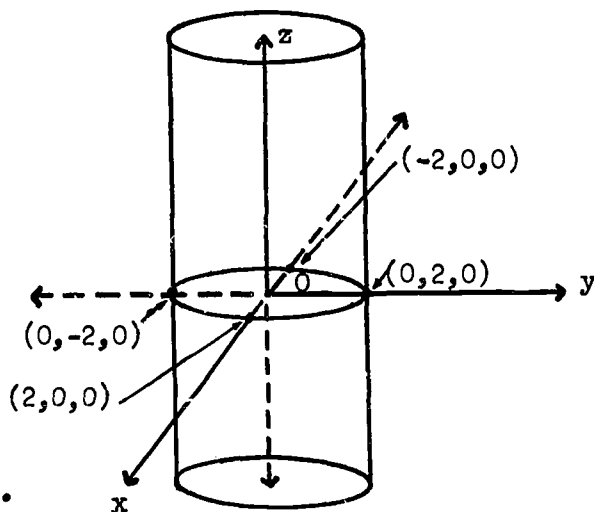

\* (d) A "sandwich" consisting of the points on and between the planes  $y = -1$  and  $y = 1$  intersect the sphere in a portion of the sphere such as the one depicted on the right.

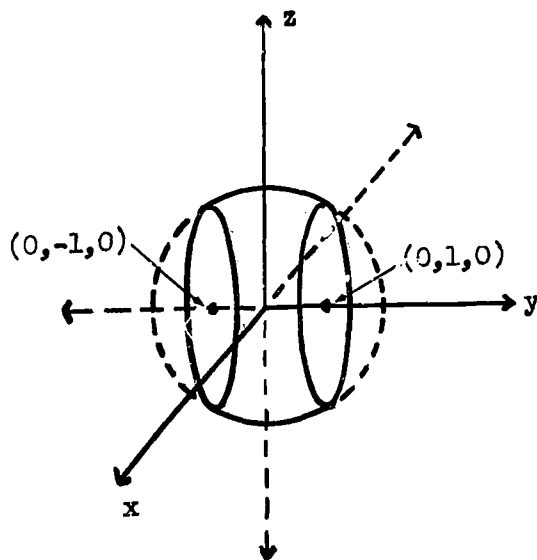

### 9.19 Solutions to Review Exercises

1. Perhaps the football field, but this could be contested.
2. (a) infinitely many      (b) infinitely many      (c) one
3. (a) true  
 (b) false  
 (c) false  
 (d) false  
 (e) true

4. (a)  $(2, 2, 2)$

(b)  $(-14, -14, -7\frac{1}{2})$

5. square root of 50, square root of 338 or  $13\sqrt{2}$

6. (a) 5

(b) 13

(c) 9

7. (a)

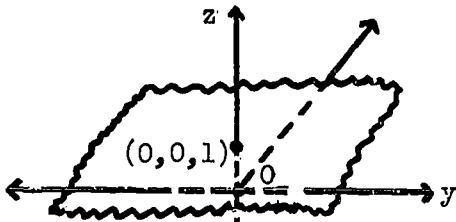

(b)

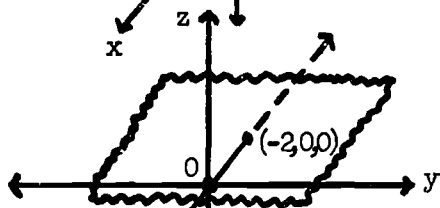

(c)

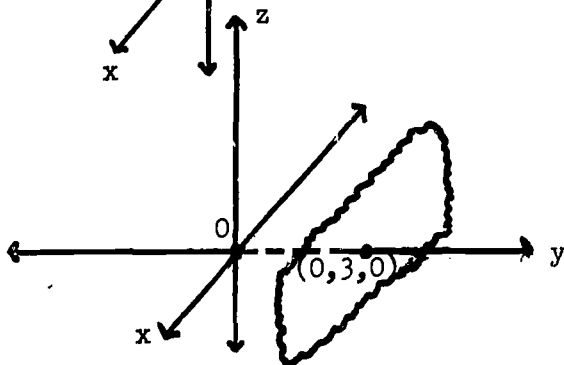

\*8. (a) See previous sketches of sphere with center at origin. Radius of this sphere will be 3.

(b) The result would be a sphere because a transformation is an isometry.

(c)

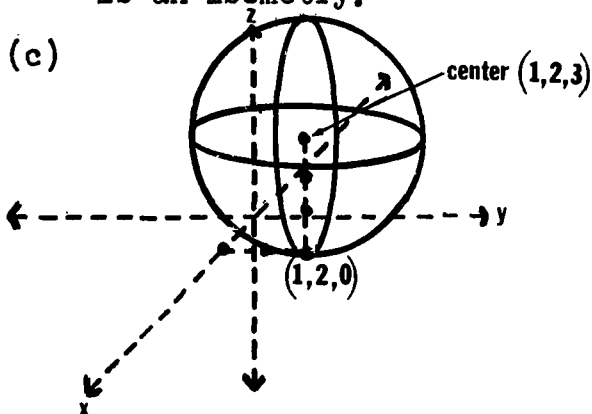

- (d) A sphere centered at the point  $(2,1,3)$  and with radius 2.

Suggested Chapter Test Items

- I. Complete each sentence by writing the words always, sometimes, or never in the space provided.
- (a) Two distinct parallel lines are \_\_\_\_\_ contained in exactly one plane.
- (b) Three parallel planes \_\_\_\_\_ intersect in a line.
- (c) Given three points, there is \_\_\_\_\_ one and only one plane that contains them.
- (d) Two planes \_\_\_\_\_ intersect in a point:
- (e) Two distinct planes which are both perpendicular to a third plane are \_\_\_\_\_ parallel to each other.
- (f) A line \_\_\_\_\_ intersects a plane in exactly one point if it is not contained in the plane.
- (g) If a line intersects one of two parallel planes, then it \_\_\_\_\_ intersects the other plane.
- II. Using an indirect approach, give a convincing argument to show that a line which is neither in a given plane nor parallel to it must intersect the plane in exactly one point.

III. Give a verbal description of each of the following sets of points in affine 3-space.

- (a)  $\{P(x,y,z): y = 0, z = 0\}$
- (b)  $\{P(x,y,z): x = 1, y = 2\}$
- (c)  $\{P(x,y,z): z = 3\}$

IV. The given figure depicts a cube in a rectangular coordinate system. Each side of the cube is 4 units long.

- (a) Find the coordinates of Points D, F, and C.
- (b) Find the coordinates of M, the mid-point of  $\overline{DF}$ .
- (c) Find the lengths of  $\overline{MC}$ ,  $\overline{DM}$ , and  $\overline{DC}$ .
- (d) Show that D, M and C are vertices of a right triangle.

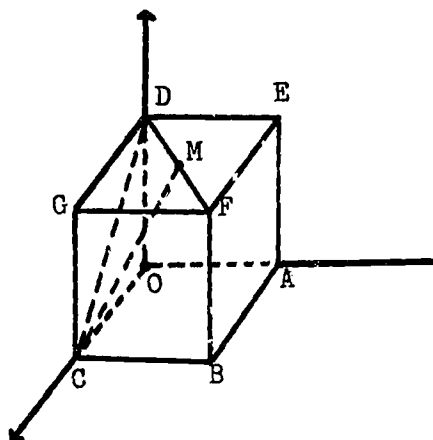

V. Give set descriptions for each of the following surfaces in rectangular space.

- (a) The set of all points with z-coordinate equal to 3.
- (b) The set of all points which are 5 units distant from the origin.
- (c) The cylinder of revolution with the x-axis as its axis and with radius equal to 3.
- (d) The right circular cone with center at the origin, the z-axis as its axis, and with  $\alpha = 45^\circ$ .

Answers to Test Items

- I. (a) always  
(b) sometimes  
(c) sometimes  
(d) never  
(e) sometimes  
(f) always  
(g) sometimes (the line might be contained in one plane).
- II. Suppose line  $\ell \notin \pi$  intersects  $\pi$  in A. Could B be another intersection point of  $\ell$  and  $\pi$  and be distinct from A? Two points A and B determine a line  $\overleftrightarrow{AB}$  which must be contained in  $\pi$ , since we observed that if two points of a line are in a plane, then the entire line is contained in that plane. But this would contradict our assumption that  $\ell \notin \pi$ . Consequently A is the only intersection point of  $\ell$  and  $\pi$ .
- III. (a) A line, the x-axis  
(b) A line parallel to the z-axis and including the point (1,2,0).  
(c) A plane, parallel to the xy-coordinate plane and including the point (0,0,3).
- IV. (a) D(0,0,4); F(4,4,4); C(4,0,0)  
(b) M(2,2,4)  
(c)  $MC = \sqrt{24}$ ;  $DM = \sqrt{8}$ ;  $DC = \sqrt{32}$

(d) Since  $(\sqrt{24})^2 + (\sqrt{8})^2 = (\sqrt{32})^2$ , the triangle DFC is a right triangle by the converse of the Pythagorean theorem.

- V. (a)  $\{P(x,y,z): z = 3\}$   
(b)  $\{P(x,y,z): x^2 + y^2 + z^2 = 25\}$   
(c)  $\{P(x,y,z): y^2 + z^2 = 9\}$   
(d)  $\{P(x,y,z): x^2 + y^2 = z^2\}$