

DOCUMENT RESUME

ED 045 854

08

VT 012 411

AUTHOR Leporini, Frank E.; And Others
 TITLE The General Woodworking Core Curriculum. Project
 ABLE: Development and Evaluation of an Experimental
 Curriculum for the New Quincy (Mass.)
 Vocational-Technical School.
 INSTITUTION American Institutes for Research, Pittsburgh, Pa.:
 Quincy Public Schools, Mass.
 SPONS AGENCY Office of Education (DHEW), Washington, D.C. Bureau
 of Research.
 REPORT NO TR-16
 BUREAU NO ER-5-0009
 PUB DATE Jul 70
 CONTRACT CEC-5-85-019
 NOTE 209p.

EDRS PRICE MF-\$1.00 HC-\$10.55
 DESCRIPTORS Behavioral Objectives, *Core Curriculum, *Curriculum
 Development, *Individualized Instruction,
 Individualized Programs, *Industrial Education, Job
 Analysis, Learning Activities, Occupational
 Clusters, Occupational Information, Performance
 Criteria, Task Performance, *Woodworking
 IDENTIFIERS *Project ABLE

ABSTRACT

This report describes the development of the Project
 ABLE General Woodworking Core Curriculum and is intended as an
 administrator's and instructor's manual for those schools field
 testing the instructional system. In the developmental process,
 analysis of a large number of occupations related to the woodworking
 family identified clusters or sub-families which were then analyzed
 for common skills and knowledges. Job descriptions and task
 enumeration were followed by task descriptions and analyses, and
 behaviorally stated performance objectives, derived from task and
 analyses, were translated into criterion tests called performance
 evaluation sets. To meet a major project objective of individualized
 instruction, learner activity guides which include student-instructor
 options for selecting media and methods of instruction to meet
 individual needs, were developed and are appended. Additional
 documentation of other developmental efforts are also appended. For
 use in field testing, this report must be supported by descriptions
 and documents provided in the Project ABLE Fifteenth Technical
 Report, available as ED 042 920. (Author/SB)

ED0 45854

21

SEP 24 1970

SIXTEENTH TECHNICAL REPORT

PROJECT ABLE

DEVELOPMENT AND EVALUATION OF AN
EXPERIMENTAL CURRICULUM FOR THE
NEW QUINCY (MASS.) VOCATIONAL-TECHNICAL SCHOOL

*THE GENERAL WOODWORKING
CORE CURRICULUM*

U.S. DEPARTMENT OF
HEALTH, EDUCATION, AND WELFARE
Office of Education
Bureau of Research

July 1970

ED0 45854

DEVELOPMENT AND EVALUATION OF AN EXPERIMENTAL CURRICULUM
FOR THE NEW QUINCY (MASS.) VOCATIONAL-TECHNICAL SCHOOL

Project ABLE

The General Woodworking Core Curriculum

Project No. 5-0009
Contract No. OE-5-85-019

Frank E. Leporini, Shop Supervisor
Quincy Vocational-Technical School

Glen E. Neifing, AIR

J. William Ullery, AIR

July 1970

The research reported herein was performed pursuant to a contract with the Office of Education, U. S. Department of Health, Education, and Welfare. Contractors undertaking such projects under Government sponsorship are encouraged to express freely their professional judgment in the conduct of the project. Points of view or opinions stated do not, therefore, necessarily represent official Office of Education position or policy.

Quincy Public Schools
Quincy, Massachusetts

and

American Institutes for Research
Pittsburgh, Pennsylvania

U.S. DEPARTMENT OF HEALTH, EDUCATION
& WELFARE
OFFICE OF EDUCATION
THIS DOCUMENT HAS BEEN REPRODUCED
EXACTLY AS RECEIVED FROM THE PERSON OR
ORGANIZATION ORIGINATING IT. POINTS OF
VIEW OR OPINIONS STATED DO NOT NECES-
SARILY REPRESENT OFFICIAL OFFICE OF EDU-
CATION POSITION OR POLICY.

TABLE OF CONTENTS

	Page
FOREWORD	iv
ACKNOWLEDGEMENT	v
PROJECT ABSTRACT	vi
REPORT SUMMARY	vii
INTRODUCTION	1
RATIONALE	9
DEVELOPMENT	
Methodology for Selection of Training Programs	11
Management and Evaluation	18
Target Population	20
Course Organization and Strategy	22
Initial Testing and Validation	30
RECOMMENDATIONS	35
SELECTED REFERENCES	37

LIST OF FIGURES

	Page
1. Goals for Vocational-Technical Education	6
2. Do You Have An Instructional System for Vocational and Technical Education?	7
3. Individualized Learner Activity Process Within An Instructional System	8
4. Frequency Chart of Job Skills	12
5. Chart of Developmental Activity by Sub-Families	13
6. Three Year General Woodworking Program	16
7. Diagram of Sample Job Structure	17
8. Flow Chart of Instructional Systems Development Process	19
9. Self-Scoring Response Card	24
10. Occupational Readiness Record	25
11. Student Tracking System	26
12. Training Aids (not filmed) (photograph)	28
13. Performance Evaluation (not filmed - photograph)	33

APPENDIX

- A. JOB TITLE ENUMERATION
- B. GENERAL WOODWORKING OCCUPATIONAL ANALYSES
- C. PERFORMANCE OBJECTIVES BY JOB FAMILY CLUSTERS
- D. PERFORMANCE OBJECTIVES FOR BASIC WOODWORKING CORE PROGRAM
- E. LEARNER ACTIVITY GUIDE AND PERFORMANCE EVALUATION SET:
SAMPLE MODULE
- F. TIME REQUIRED TO COMPLETE LEARNING AND PERFORMANCE
ASSESSMENT ACTIVITIES
- G. RECOMMENDED EQUIPMENT, TOOLS, SUPPLIES, AND TRAINING AIDS

FOREWORD

This report is intended to serve a number of purposes. For example:

- (1) The contract with USOE requires the project to file periodic reports on research and development activities.
- (2) The contract obligates the project to disseminate the results of its research. Thus, the job analyses, the behavioral objectives, and the other documents in the appendices will be made available with the distribution of this report. (Distribution, generally speaking, will be limited to ES'70 network members and member cities of the Council of Great City Schools.)
- (3) An instructor's manual is needed to support dissemination of General Woodworking curriculum materials for field testing in selected schools.

Information on the management of instructional systems development process, job and task analysis, criterion test construction, and evaluation is available in the Project ABLE Fifteenth Technical Report. That report also includes the necessary evaluation instruments, implementation and evaluation procedures, instructor performance checklists, progress charts, management control documents, etc. Thus, the report on the General Woodworking Core Curriculum must be used in conjunction with other ABLE manuals where replication of the instructional system is to be attempted.

ACKNOWLEDGMENT

The General Woodworking Core Curriculum has had the benefit of intensive effort over a period of several years. Mr. Maurice J. Daly, Assistant Superintendent of Schools in Quincy (and one of the initiators of Project ABLE) provided both a framework for the identification of job family clusters and methods of identifying common tasks such as that described in this report. Mr. Robert E. Pruitt, former Superintendent of the Quincy Public Schools, worked with Mr. Daly in the establishment of Project ABLE. Mr. Pruitt is well known for his efforts in furthering innovative approaches to individualized instruction. Dr. Robert M. Gagné, formerly of AIR (and co-initiator of ABLE with Mr. Daly and Mr. Pruitt) contributed his expertise in the areas of behavioral science and instructional technology. Mr. Joseph S. Nicastro, Quincy Project ABLE Coordinator during the past three years, has provided extensive administrative guidance in the areas of systems development and public school operations. The present Quincy members of the Project ABLE Policy Board--Dr. Lawrence P. Creedon, Mr. William Phinney and Mr. Maurice Daly--have devoted many hours to the early operational problems in the Woods program. Mr. Laurence H. Babin, Director of the Quincy Vocational-Technical School, has also provided much support for the new curriculum and research efforts within the Quincy Vocational School. Mr. Boyd Kowal, an AIR Research Scientist and learning psychologist, assisted in the behavioral analysis of the Woodworking job family. Many other persons have contributed much time and effort including teachers and administrators from Quincy, and research support personnel from AIR.

ABSTRACT: Project ABLE

USOE Project No. 5-0009
Contract No. OE-5-85-019

A Joint Research Project of: Public Schools of Quincy, Massachusetts and American Institutes for Research

Title: DEVELOPMENT AND EVALUATION OF AN EXPERIMENTAL CURRICULUM FOR THE NEW QUINCY (MASS.) VOCATIONAL-TECHNICAL SCHOOL

Objectives: The principal goal of the project is to demonstrate increased effectiveness of instruction whose content is explicitly derived from analysis of desired behavior after graduation and which, in addition, attempts to apply newly developed educational technology to the design, conduct, and evaluation of vocational education. Included in this new technology are methods of defining educational objectives, deriving topical content for courses, preparing students in prerequisite knowledges and attitudes, individualizing instruction, measuring student achievement, and establishing a system for evaluating program results in terms of outcomes following graduation.

Procedure: The procedure begins with the collection of vocational information for representative jobs in eleven different vocational areas. Analysis will then be made of the performances required for job execution, resulting in descriptions of essential classes of performance which need to be learned. On the basis of this information, a panel of educational and vocational scholars will develop recommended objectives for a vocational curriculum which incorporates the goals of (1) vocational competence; (2) responsible citizenship; and (3) individual self-fulfillment. A curriculum will then be designed in topic form to provide for comprehensiveness and also flexibility of coverage for each of the vocational areas. Guidance programs and prerequisite instruction to prepare junior high students will also be designed. Selection of instructional materials, methods, and aids, and design of materials, when required, will also be undertaken. An important step will be the development of performance measures tied to the objectives of instruction. Methods of instruction will be devised to make possible individualized student progression and selection of alternative programs, and teacher-training materials will be developed to accomplish inservice teacher education of Quincy School personnel. A plan will be developed for conducting program evaluation not only in terms of end-of-year examinations, but also in terms of continuing follow-up of outcomes after graduation.

REPORT SUMMARY

This report describes the development of the Project ABLE General Woodworking Core Curriculum. A brief review of the goals and objectives of the Project is included along with a rationale for the development of instructional systems.

The process was initiated by a careful analysis of a large number of occupations related in one way or another in the Woodworking family. This enabled the identification of a number of clusters or sub-families. Such occupations were then analyzed for common skills and knowledges. One method employed was a frequency count of common tasks utilizing a matrix of job titles by tasks performed. Also considered were job requirements, conditions, trends and other factors. Flow charts for job family training were developed. Job descriptions and task enumerations were followed by task descriptions and task analyses. Behaviorally stated performance objectives derived from the task analyses were translated into criterion tests called performance evaluation sets. Extensive documentation of such efforts is provided in the appendices.

Learner activity guides, which include student-instructor options for maximum flexibility in selecting media and methods of instruction appropriate to each individual learner's needs, have been provided. Such devices are examples of attempts to meet major project objectives of individualization of instruction through the application of modern educational technology. Many documents and samples of instruments, performance evaluation modules, and other materials are included in the report. A description of the initial procedures used in testing and revising program materials is also included.

The report will serve as an administrator's and instructor's manual for those schools wishing to field test the instructional system. However, the report, for field testing applications, must be supported by descriptions and documents provided in the Project ABLE Fifteenth Technical Report, "The Management and Evaluation Plan for Instructional Systems Development for Vocational-Technical Education."

INTRODUCTION

Project ABLE is a "systems" approach to occupational education. It is: (1) based upon a unique combination of the most effective features of modern educational technology; (2) an appropriate use of the state-of-the-art in vocational education using some of the best existing innovative methods; (3) A program in which there are no student failures; (4) an operational system within the financial capability of most school systems; (5) an emphasis on student activities in the study of vocational skills and knowledges; and (6) a research and development program centered in a local school system.

Characteristics

Individualized instruction: each student

Enters chosen job family program at a level corresponding to his previous experience and knowledge.

Is guided to learning experiences consistent with goals agreed upon by him and his instructor.

Learns at a rate based on his own ability by using self-instructional materials and techniques.

Has greater flexibility in allowing for a change of program with fewer penalties.

Experiences successes in learning--there are no failures. Some students simply take longer than others to accomplish goals.

New roles for teachers and students

The teacher is more able to perform as a diagnostician, tutor and manager of learning.

The instructor is freed to assist the individual student with accomplishment of the student's goals and in accordance with his needs.

Students participate in the selection of learning materials from a variety of educational media.

Each student is required to be actively involved in not only the learning process but his evaluation and program management.

There is student and teacher involvement in program development and testing.

Job-based instructional units

Detailed job analyses are used to determine needed skills.

Jobs are organized into clusters and skill families.

Brief performance evaluation tests and learning activity guides are developed for each task within the occupational family.

New methods of sequencing instruction by job levels and hierarchies of skills and knowledges are used.

Clearly stated performance objectives are based on a scientific task analysis.

The focus is on job entry level skills and knowledges by job levels within a family cluster.

There are no age or grade level restrictions to programs organized by job levels.

Units are activity and job-oriented rather than classroom or theory-oriented.

At whatever point the student chooses to leave he does so with job-related proficiencies.

Students know the standards of performance and the nature of all evaluation.

Students know exactly where to concentrate remedial study.

Flexibility

Better integration of cooperative work-study programs.

Use of existing or new course materials possible.

Programs of study which can be easily modified to fit the unique needs of any school system or student.

Changes more easily accomplished with technological advances in job family (evaluation and management plan).

Student advancement by job levels (not grade levels) with multiple entry and exit points.

Performance evaluation

Provides self-evaluation tools, preventing premature formal testing, while saving teacher time and student embarrassment.

Standards are derived from a task analysis.

Test structure informs student where to concentrate any remedial study.

Students are permitted to skip instructional units by simply demonstrating an adequate level of knowledge and skill.

Occupational readiness certification specifies skills of graduates.

Testing procedures provide students with immediate "knowledge of results."

Performance standards are provided for instructional staff.

Some Anticipated Benefits

Students build self-confidence through successful learning experiences (especially important for slow learners).

Fewer discipline problems (50% fewer in one instance).

Fewer dropouts.

Greater flexibility for students desiring a change of program of study.

Marketable job-related skills for every student.

Greater dignity for the student; no failures combined with a joint student-teacher learning effort in objective accomplishment.

Evaluation methods (student, teacher, program) economical and simple for students, teachers and administrators.

Minimal instructor training to operate system with emphasis and focus on inservice training.

Systems techniques and better management with quality control throughout the developmental process and ongoing operation.

Reduction of clerical chores for teachers.

More easily adapted to new school-wide flexible scheduling systems.

Efficiency and cost savings in equipment and supplies because of the detailed specification of instructional objectives.

Ability to specify to publishers, precise instructional objectives for better learning material development.

Instructional Example

1. A student enters the study of a particular job family in light of his present skills and interests.
2. He is provided a brief activity guide for each job task, giving him
 - a. a clear statement of what he should be able to do.
 - b. a suggested guide to optional learning experiences (also method, media, materials, etc.).
 - c. self-evaluation aids to check his own progress.
3. He follows the guide, obtaining from the teacher counsel and advice as necessary. Team approaches, where students help each other, are frequently used. He does not work in a vacuum all alone.

4. When he feels competent to perform the unit task requirements, he goes to the teacher who evaluates his task performance and knowledges according to a guide provided to both student and teacher. (There are no secret test items; the student is told at the outset what abilities he will have to demonstrate.) If the student has had job experience and can demonstrate the required level of skills and knowledges, he can bypass most of the instruction and move rapidly to more advanced tasks.
5. If he demonstrates competence, the student and teacher select the next task to be learned. In view of his experience and interests he may shift goals within a job family or even change job families. The modules are short and related to job tasks providing flexibility for such changes at any time.
6. The student moves along as rapidly as he is ABLE, not in lock-step with other students. He moves at a pace at which he can be successful.

Questions and Answers

- Q. Does this Program seek to standardize vocational education everywhere?
- A. No. Project ABLE permits, more readily than any other system, flexibility in both choice of program and choice of teaching materials. The rigor is in the method of job analysis and quality control procedures in systems development.
- Q. Does it involve the preparation of the instructional material itself (texts, films, tapes, etc.)?
- A. No. Not unless absolutely necessary. The learning experience used for developing a particular behavior is the option of the student and teacher in light of available school materials and opportunities. ABLE provides references and options to materials which could be used. The system permits complete freedom and flexibility in the choice of any learning materials or methods (for readers and nonreaders) which will help in the accomplishment of unit objectives for each student. Such research projects should identify topics where improved materials are needed, especially audio-visual materials. Publishers should then be encouraged to build materials to fit the precisely stated instructional objectives. This should result in more supervision and control by school systems over the materials being marketed by educational publishers.
- Q. Would cooperating school systems have to adopt the same series of modules as used in Project ABLE?
- A. No. Schools can recombine the task related modules into other job groupings where desired. It is, however, suggested that ABLE groupings be used during the initial

field testing. On the other hand, any teacher can select individual units to be used to teach specific job tasks. Once several families are developed, many flexible groupings will be possible--such as the commonalities in the autobody and sheet metal clusters.

- Q. Where does the program for teaching related academic subjects (reading, math, science, etc.) fit into this plan?
- A. Methodology used in dealing with the vocational curriculum is also applicable to academic curriculum as it is used as a component of vocational education. Some academic curriculum materials have already been accumulated in this manner through ABLE and other projects. However, this is a significant and expensive undertaking. Until development is more advanced, a thorough search should be made for materials proven successful in upgrading student abilities in the various academic areas and appropriate guidelines to their use should be devised. Clearly stated instructional objectives must be available for a number of job family areas before relevant academic program development can be realized.
- Q. Is it envisioned that ABLE will include a guidance program (career decision making, student assessment, prescribing individual learner needs, etc.)?
- A. A complete guidance package must be developed, but the effort involved is significant. Again, some work in such areas has been completed by ABLE and other groups.
- Q. What about evaluation of ABLE programs?
- A. As learning units are tried out, they are modified wherever it is found that students cannot understand the objectives, follow the instructions, or pass the performance requirements. The development of a unit is marked "completed" only after evidence indicates that it really works. Evaluation is also based on several measures of student involvement. Evaluation, in general, takes place on several levels. There is a system of revision based on validation against employees on the job. Another is based on how students perform in an ongoing training program. Thirdly, there will be a post-graduation revision based on how students perform on jobs. A rather technical discussion of project, program, student and teacher evaluation is presented in the 15th Technical Report. This, in part, represents an application of "new educational technology."

GOALS FOR VOCATIONAL – TECHNICAL EDUCATION

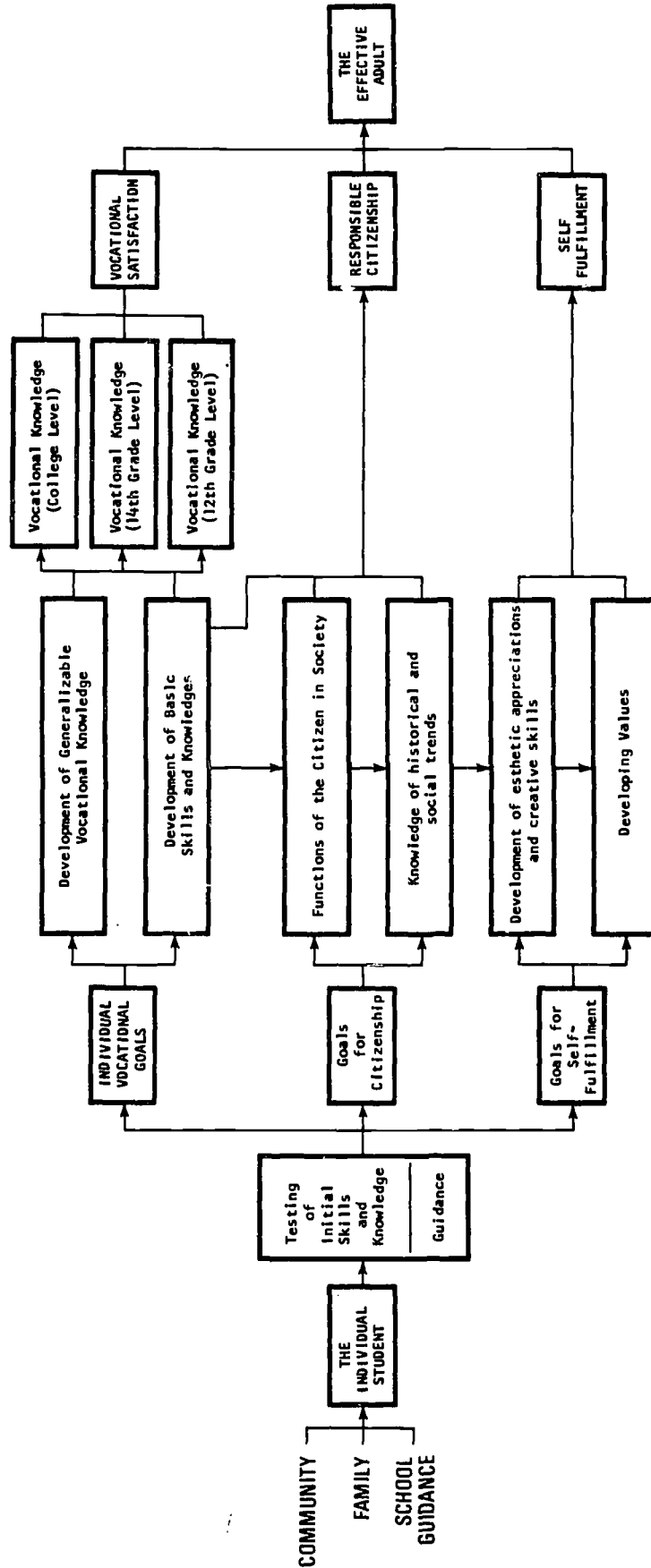

Figure 1.

DO YOU HAVE A LEARNER-CENTERED INSTRUCTIONAL SYSTEM FOR VOCATIONAL AND TECHNICAL EDUCATION?

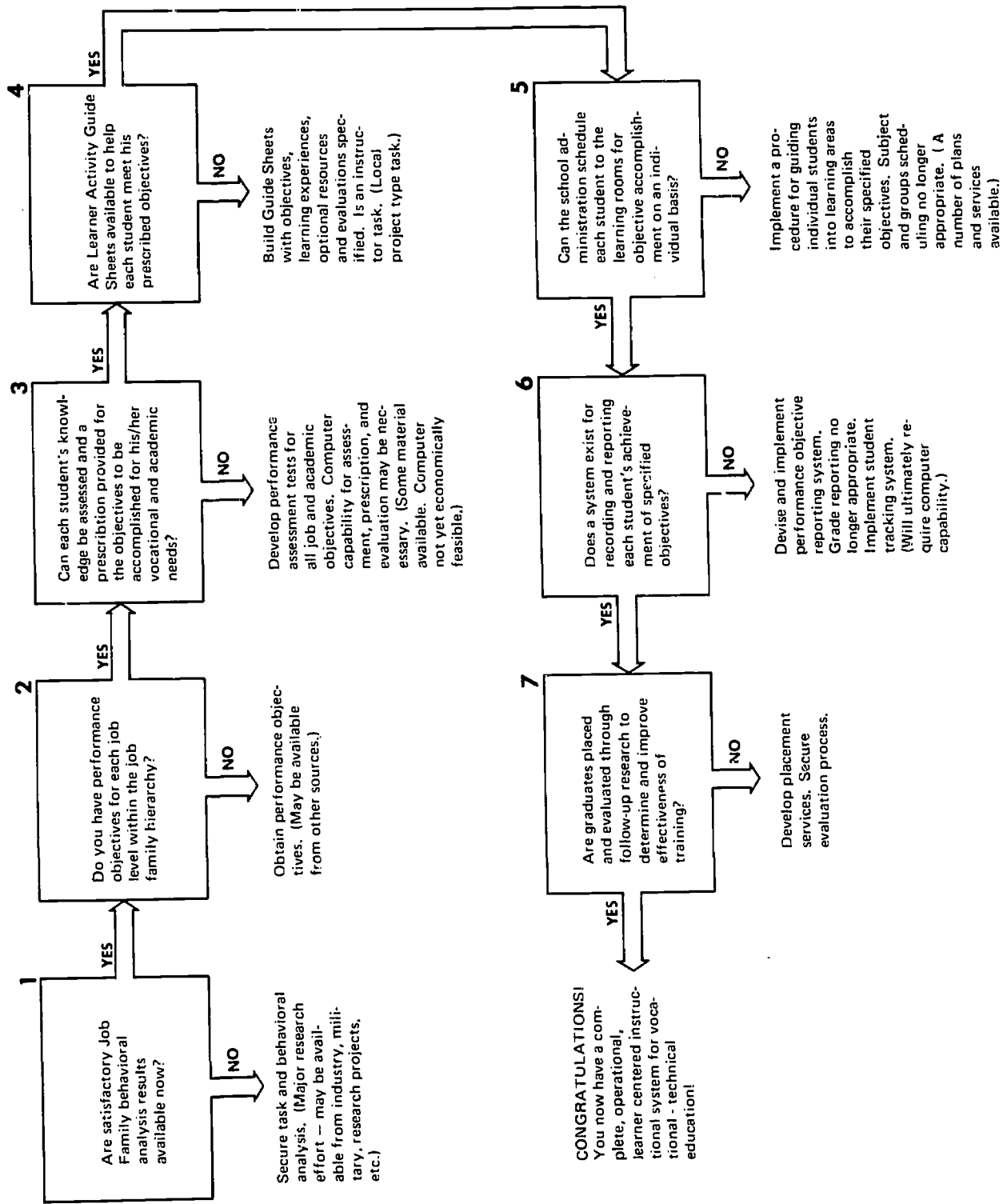

Figure 2.

INDIVIDUALIZED LEARNER ACTIVITY PR

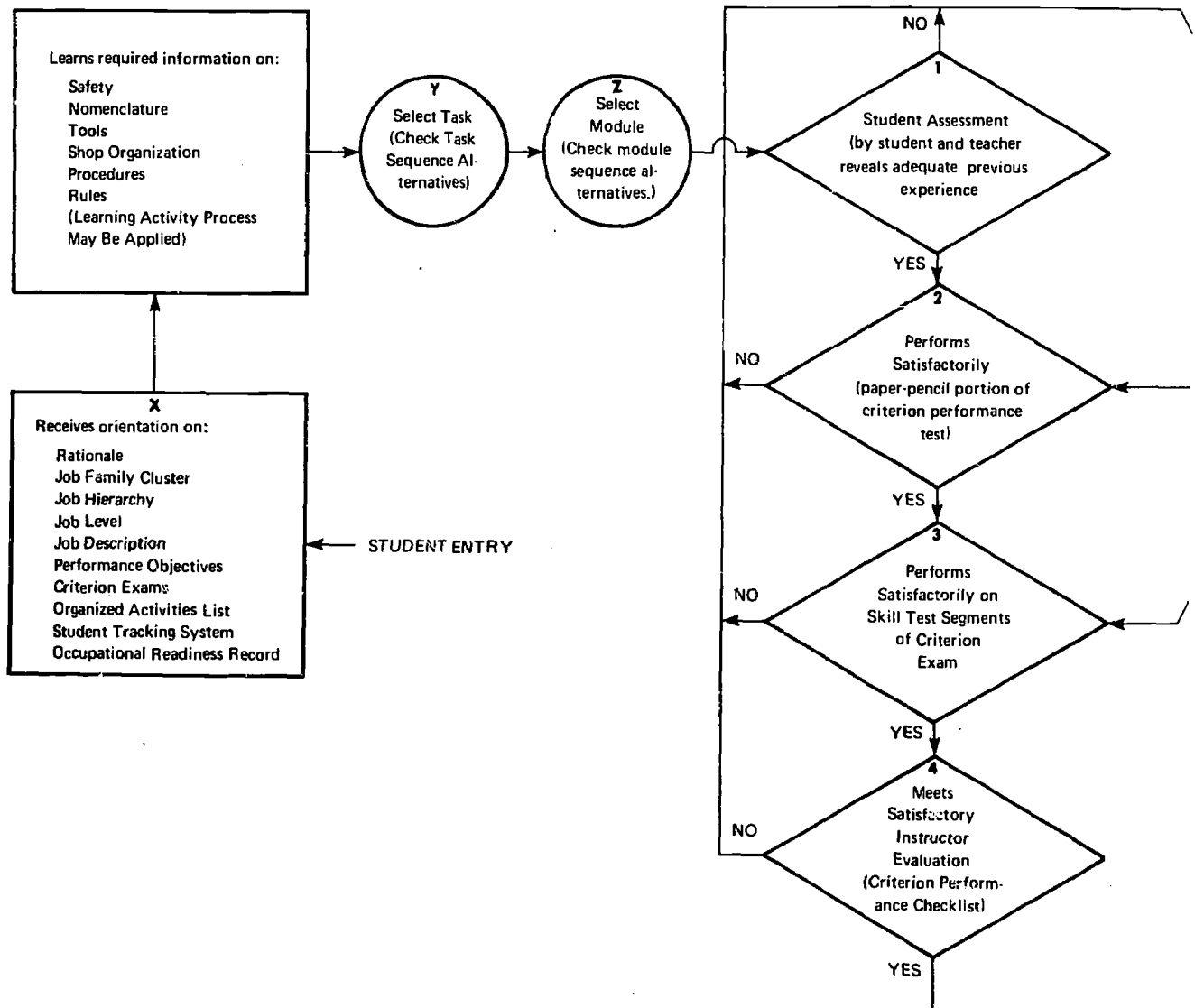
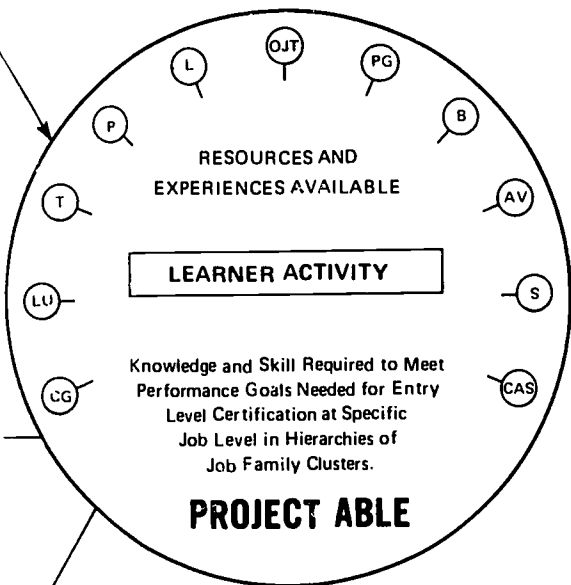

Figure 3.

PROCESS WITHIN AN INSTRUCTIONAL SYSTEM



CODE FOR RESOURCES AND EXPERIENCES AVAILABLE

- LU = ABLE adjunctive type learning unit
- T = Teacher assistance and tutoring
- P = Programmed materials
- L = Laboratory practice and experience
- OJT = On-the-job experience and practice
- PG = Peer group tutoring and assistance
- B = Books, manuals, technical materials, various printed media, and available shelf materials.
- AV = Audio visuals such as CCTV, film loops, photographs, drawings, samples.
- S = Simulators, mock-ups, and various mechanical teaching-learning devices.
- CG = Career guidance
- CAS = Critical Academic Skills

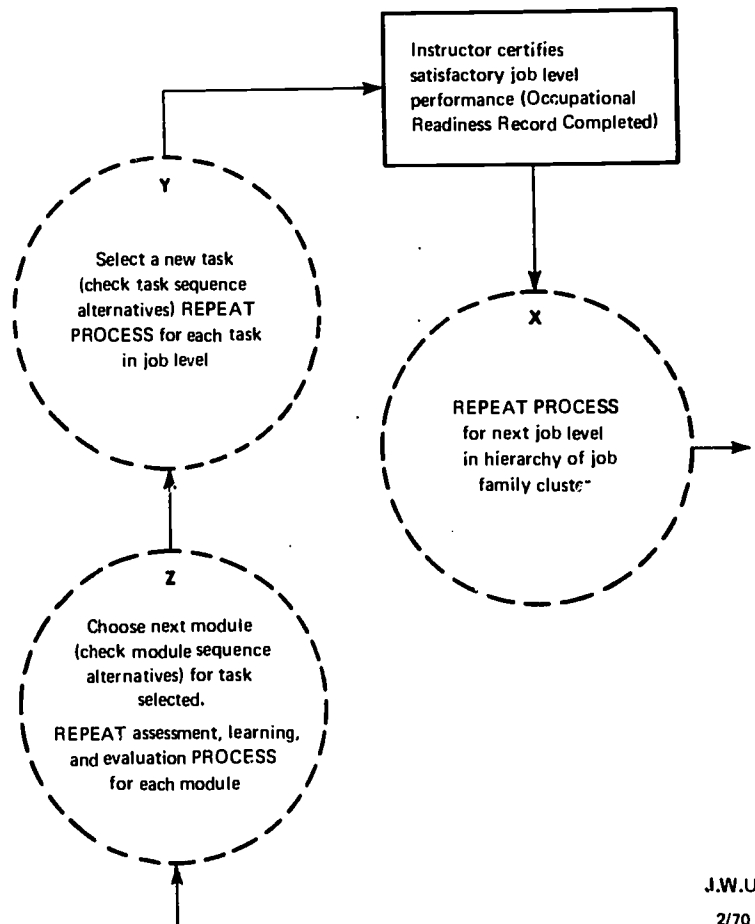

RATIONALE

The methodology for the selection of training programs for development by Project ABLE has been defined in the First Quarterly Technical Report, AIR, 1965. The criteria and considerations outlined in the report and applied to the development of Woodworking curricula focused on jobs which:

1. In comparison with related jobs, require performances of a wider variety of tasks and a larger range of skill levels.
2. Require an appropriate amount of vocational training time (given various limitations of a vocational-technical school program).
3. Have entrance, apprenticeship, or on-the-job training requirements which can be met better as a result of vocational training. Thus, jobs for which the training graduate could substantially meet the entrance requirements, or would be allowed to progress more rapidly through apprenticeship and additional training programs, could be favored for selection. Jobs which could be entered only after long service in another job, or only after an extended, fixed period of apprenticeship, or additional training, or only by meeting requirements beyond the control of the training agency would be less desirable candidates for selection. This principle is not intended to imply that the content of vocational training should include only that which pays off immediately in a job. It is intended to foster meaningful and lasting vocational rewards for the student who performs successfully in training.
4. Are appropriate with respect to the cost, size, support requirements, and expected usage of training facilities and training equipment.

5. Are predictable with respect to the skills and knowledges which will be required in the next five years. Of course, radical changes may take place unexpectedly in any vocational area. In such a case, training plans can be prepared or modified when the performance, skills and knowledges can be identified, but not before.
6. Have favorable employment expectations in the time period for which training is being prepared.

Such steps are an important part of the broader feasibility study.

One of the major goals of the Project is that of applying newly developed educational technology to the design, conduct and evaluation of vocational education. Techniques of identifying objectives and stating the behaviors desired of a student when he has completed the particular course of instruction are basic to the "newly developed educational technology." The behaviors for vocational areas are derived from an analysis of tasks or job activity in the occupational family in which training is to be offered. The "newly developed educational technology" then includes the processes of job and task description and analysis. Careful attention to such procedures should provide the basis for the identification of learnable skills and knowledges. (Refer to other Project ABLE documents for a more detailed discussion of instructional systems development.)

DEVELOPMENT

Methodology for Selection of Training Programs

In recent years, many curriculum experts and vocational educators have advocated the need for defining and developing basic core content curriculum for the General Woodworking job family. Such a course is now in operation at the grade ten level in Quincy. (Actually, because of the nature of the job family analysis, such programs have no grade or age level restrictions.)

This identification was accomplished by describing all selected occupations in the Woods area, listing all basic tasks, conducting a task description and analysis for each job and developing course and topic objectives for the tasks. (See Appendices A, B, and C.) A frequency count of objectives identified the extent to which given skills and knowledges appeared in a number of selected occupations. (See Figure 4.)

The results of the frequency count served as a basis for selecting those skills and knowledges to be included in the Basic Woodworking Core Curriculum. By definition, those skills and knowledges which are required by all or a large number of occupations in the area can be considered as "basic" or "core" to the job family.

Objectives were then prepared for the basic program (see Appendix D) and arranged in order of frequency. (Such a structure may not be related to the desired sequencing of instruction and learning.) The exact number of objectives to be completed in the basic program was not specified, since it was only possible to make a rough estimate of the number of learning activities an individual student could complete in one year. Obviously, a program of individualized instruction will operate by job levels--not grade levels. And, accomplishment of goals and objectives will vary with the ability, experience, and effort of each learner. Thus, some students simply take longer than others to certify competency at the basic job level.

At this writing, it appears that the Basic Woodworking course covers the requirements of approximately one-third or ten occupa-

WOODWORKING FAMILY
CORE PROGRAM

FREQUENCY CHART
of
JOB SKILLS

	Reading Blueprints	Measuring to Nearest Inch	Computing Lumber Reqrmts.	Using Spirit Level	Using Hammer	Using Six-Foot Rule	Computing Area	Using Tin Snips	Computing Costs	Sawing Lumber	Using Level	Measuring to Nearest 1/4"	Measuring Angles	Using Hand Drill	Using Straightedge	Using Jigsaw	Measuring to Nearest 1/16"	Using Scriber	Using Planes	Using Nailset	Using Square	Using Screwdrivers	Identifying Lumber	Layout	Using Knife	Using Chisels	Identifying Joinery	Computing Dimensions	Fitting Joints	Milling
Cribber	✓	✓	✓	✓	✓	✓	✓	✓	✓	✓	✓	✓	✓	✓	✓	✓	✓	✓	✓	✓	✓	✓	✓	✓	✓	✓	✓	✓	✓	
Roofer	✓	✓	✓	✓	✓	✓	✓	✓	✓	✓	✓	✓	✓	✓	✓	✓	✓	✓	✓	✓	✓	✓	✓	✓	✓	✓	✓	✓	✓	
Framer	✓	✓	✓	✓	✓	✓	✓	✓	✓	✓	✓	✓	✓	✓	✓	✓	✓	✓	✓	✓	✓	✓	✓	✓	✓	✓	✓	✓	✓	
Finishman (INSIDE)	✓	✓	✓	✓	✓	✓	✓	✓	✓	✓	✓	✓	✓	✓	✓	✓	✓	✓	✓	✓	✓	✓	✓	✓	✓	✓	✓	✓	✓	
Finishman (OUTSIDE)	✓	✓	✓	✓	✓	✓	✓	✓	✓	✓	✓	✓	✓	✓	✓	✓	✓	✓	✓	✓	✓	✓	✓	✓	✓	✓	✓	✓	✓	
Lather (Wallboard Carp.)	✓	✓	✓	✓	✓	✓	✓	✓	✓	✓	✓	✓	✓	✓	✓	✓	✓	✓	✓	✓	✓	✓	✓	✓	✓	✓	✓	✓	✓	
Tile Applicator	✓	✓	✓	✓	✓	✓	✓	✓	✓	✓	✓	✓	✓	✓	✓	✓	✓	✓	✓	✓	✓	✓	✓	✓	✓	✓	✓	✓	✓	
Cabinet Installer	✓	✓	✓	✓	✓	✓	✓	✓	✓	✓	✓	✓	✓	✓	✓	✓	✓	✓	✓	✓	✓	✓	✓	✓	✓	✓	✓	✓	✓	
Siding Applicator	✓	✓	✓	✓	✓	✓	✓	✓	✓	✓	✓	✓	✓	✓	✓	✓	✓	✓	✓	✓	✓	✓	✓	✓	✓	✓	✓	✓	✓	
Floor Layer	✓	✓	✓	✓	✓	✓	✓	✓	✓	✓	✓	✓	✓	✓	✓	✓	✓	✓	✓	✓	✓	✓	✓	✓	✓	✓	✓	✓	✓	
Millman	✓	✓	✓	✓	✓	✓	✓	✓	✓	✓	✓	✓	✓	✓	✓	✓	✓	✓	✓	✓	✓	✓	✓	✓	✓	✓	✓	✓	✓	
Sash and Door Carpenter	✓	✓	✓	✓	✓	✓	✓	✓	✓	✓	✓	✓	✓	✓	✓	✓	✓	✓	✓	✓	✓	✓	✓	✓	✓	✓	✓	✓	✓	
Furniture Maker	✓	✓	✓	✓	✓	✓	✓	✓	✓	✓	✓	✓	✓	✓	✓	✓	✓	✓	✓	✓	✓	✓	✓	✓	✓	✓	✓	✓	✓	
Kitchen Cabinet Maker	✓	✓	✓	✓	✓	✓	✓	✓	✓	✓	✓	✓	✓	✓	✓	✓	✓	✓	✓	✓	✓	✓	✓	✓	✓	✓	✓	✓	✓	
Sprayer/Finisher	✓	✓	✓	✓	✓	✓	✓	✓	✓	✓	✓	✓	✓	✓	✓	✓	✓	✓	✓	✓	✓	✓	✓	✓	✓	✓	✓	✓	✓	
Wood Former	✓	✓	✓	✓	✓	✓	✓	✓	✓	✓	✓	✓	✓	✓	✓	✓	✓	✓	✓	✓	✓	✓	✓	✓	✓	✓	✓	✓	✓	
Formica (Plastic Top) Installer	✓	✓	✓	✓	✓	✓	✓	✓	✓	✓	✓	✓	✓	✓	✓	✓	✓	✓	✓	✓	✓	✓	✓	✓	✓	✓	✓	✓	✓	
Wood Turner	✓	✓	✓	✓	✓	✓	✓	✓	✓	✓	✓	✓	✓	✓	✓	✓	✓	✓	✓	✓	✓	✓	✓	✓	✓	✓	✓	✓	✓	
Layout Man	✓	✓	✓	✓	✓	✓	✓	✓	✓	✓	✓	✓	✓	✓	✓	✓	✓	✓	✓	✓	✓	✓	✓	✓	✓	✓	✓	✓	✓	
Hardware Applicator	✓	✓	✓	✓	✓	✓	✓	✓	✓	✓	✓	✓	✓	✓	✓	✓	✓	✓	✓	✓	✓	✓	✓	✓	✓	✓	✓	✓	✓	
Assembly Man	✓	✓	✓	✓	✓	✓	✓	✓	✓	✓	✓	✓	✓	✓	✓	✓	✓	✓	✓	✓	✓	✓	✓	✓	✓	✓	✓	✓	✓	
Boat Builder	✓	✓	✓	✓	✓	✓	✓	✓	✓	✓	✓	✓	✓	✓	✓	✓	✓	✓	✓	✓	✓	✓	✓	✓	✓	✓	✓	✓	✓	
Model Maker	✓	✓	✓	✓	✓	✓	✓	✓	✓	✓	✓	✓	✓	✓	✓	✓	✓	✓	✓	✓	✓	✓	✓	✓	✓	✓	✓	✓	✓	
Mockup Man	✓	✓	✓	✓	✓	✓	✓	✓	✓	✓	✓	✓	✓	✓	✓	✓	✓	✓	✓	✓	✓	✓	✓	✓	✓	✓	✓	✓	✓	
Pattern Rigger	✓	✓	✓	✓	✓	✓	✓	✓	✓	✓	✓	✓	✓	✓	✓	✓	✓	✓	✓	✓	✓	✓	✓	✓	✓	✓	✓	✓	✓	
Pattern Finisher	✓	✓	✓	✓	✓	✓	✓	✓	✓	✓	✓	✓	✓	✓	✓	✓	✓	✓	✓	✓	✓	✓	✓	✓	✓	✓	✓	✓	✓	
Plaster Patternmaker	✓	✓	✓	✓	✓	✓	✓	✓	✓	✓	✓	✓	✓	✓	✓	✓	✓	✓	✓	✓	✓	✓	✓	✓	✓	✓	✓	✓	✓	
Metal Patternmaker	✓	✓	✓	✓	✓	✓	✓	✓	✓	✓	✓	✓	✓	✓	✓	✓	✓	✓	✓	✓	✓	✓	✓	✓	✓	✓	✓	✓	✓	

Figure 4.

GENERAL WOODWORKING JOB FAMILY

CHART OF DEVELOPMENTAL ACTIVITY BY SUB-FAMILIES

	# of Jobs Identified	Sub-families Identified	Jobs Desc, Form II	% Selected Jobs	Jobs W/ Tasks	% Selected Jobs	Essays Jobs Desc.
<u>Sub-families</u>							
Carpentry	134		27	100%	27	100%	1
Mill Carpentry	44		13	100%	13	100%	1
Boat Building	22		9	100%	9	100%	1
Pattern Making	21		8	100%	7	88%	1
JOB FAMILY TOTALS	221	4	57	100%	56	98%	4/4

Figure 5.

tions in the sample. In addition, it serves as a base for the higher-level or more complex occupations in the hierarchy. The transition from the basic course into more specific jobs in different families can be a smooth one. The completion of the basic course also assists the student in deciding what career in woodworking to pursue. Important also is the fact that students completing the first level program are employable. They possess skills and knowledges typically required at job entry levels. The approach is uniquely suited to cooperative work-study programs, since it is likely that the early practice and reinforcement of learning will be a natural condition of the real-life experience.

The entire job family sequence provides for exit levels at various points on the hierarchy. In effect, these points serve as goals for the individual student. After he satisfies the requirements of an exit level (represented by an occupation), he knows that he has met the basic entry requirements of that occupation and can progress to the next higher job or task level. More important, he possesses the prerequisite skills and knowledges (conditions of learning) to the next higher level of learning or class of capabilities in the hierarchy. (The discussion here is in relation to Conditions of Learning, Gagné, 1965.)

General Woodworking as an occupational family was divided into three groups or clusters: General Carpentry, Mill Carpentry and Pattern Making. The Mill Carpentry sub-family is frequently labeled Cabinet Making, but it goes beyond the limited notion of constructing and/or assembling cabinets. With the trend to pre-fabrication for home units, cabinet making in the traditional sense is disappearing from the occupational world. However, Mill Carpentry remains as a craft and demands precision skills and knowledge customarily associated with the building of cabinets and furniture. (See Appendix B for a listing of jobs in each cluster, flow charts and job descriptions.)

For certain of the selected jobs to be used as the focus of training, such as All-Round Pattern Maker, a number of directly related occupations and specialties have been identified. For example, the tasks required of the All-Round Pattern Maker actu-

ally overlap seven of the eight selected jobs in the Pattern-making clusters. For the General Carpentry group, there were thirteen such jobs selected from a list of fifty-four job titles. In the Mill Carpentry cluster, sixteen jobs were judged to be representative of the forty-four job descriptions identified for that family. Specialty tasks for each of the "selected" jobs were identified and analyzed. Thus, each student can expand upon his core or common task preparation for learning activity in any one or more of the number of selected jobs within the three general clusters. Of course, study of advanced and specialty tasks in each of the three major clusters is generally undertaken after completion of the core program.

Figure 6 illustrates the options open to the student electing woodworking as his vocational area at the Quincy Vocational-Technical School. All entering students are assigned to the first level core program. Advanced or transfer students claiming experience in woodworking, are given the opportunity to demonstrate an acceptable level of performance on each of the basic job tasks. Of course, the basic core program is organized so that each student can advance at his own rate. This includes the option of bypassing instruction in those tasks in which the student feels competent. In other words, the post-performance test is also used as a pre-test for task certification. This procedure enables many students to progress more rapidly to advanced tasks. Figure 7 presents a diagram of a sample job structure showing the breakdown into duties, tasks, and activities.

After completing the first level or core program, most students elect a Woods program at the second level. If the student continues in Woods, he must choose between the three clusters offered at the second level. While there are some common advanced tasks, each of the three programs necessarily provides a different type of occupational training. For example, the Patternmaking cluster requires the capability to work to close tolerances and detail. Mill Carpentry and General Carpentry are not quite as meticulous, but offer a greater number of alternative jobs at each

Project ABLE
THREE YEAR GENERAL WOODWORKING PROGRAM

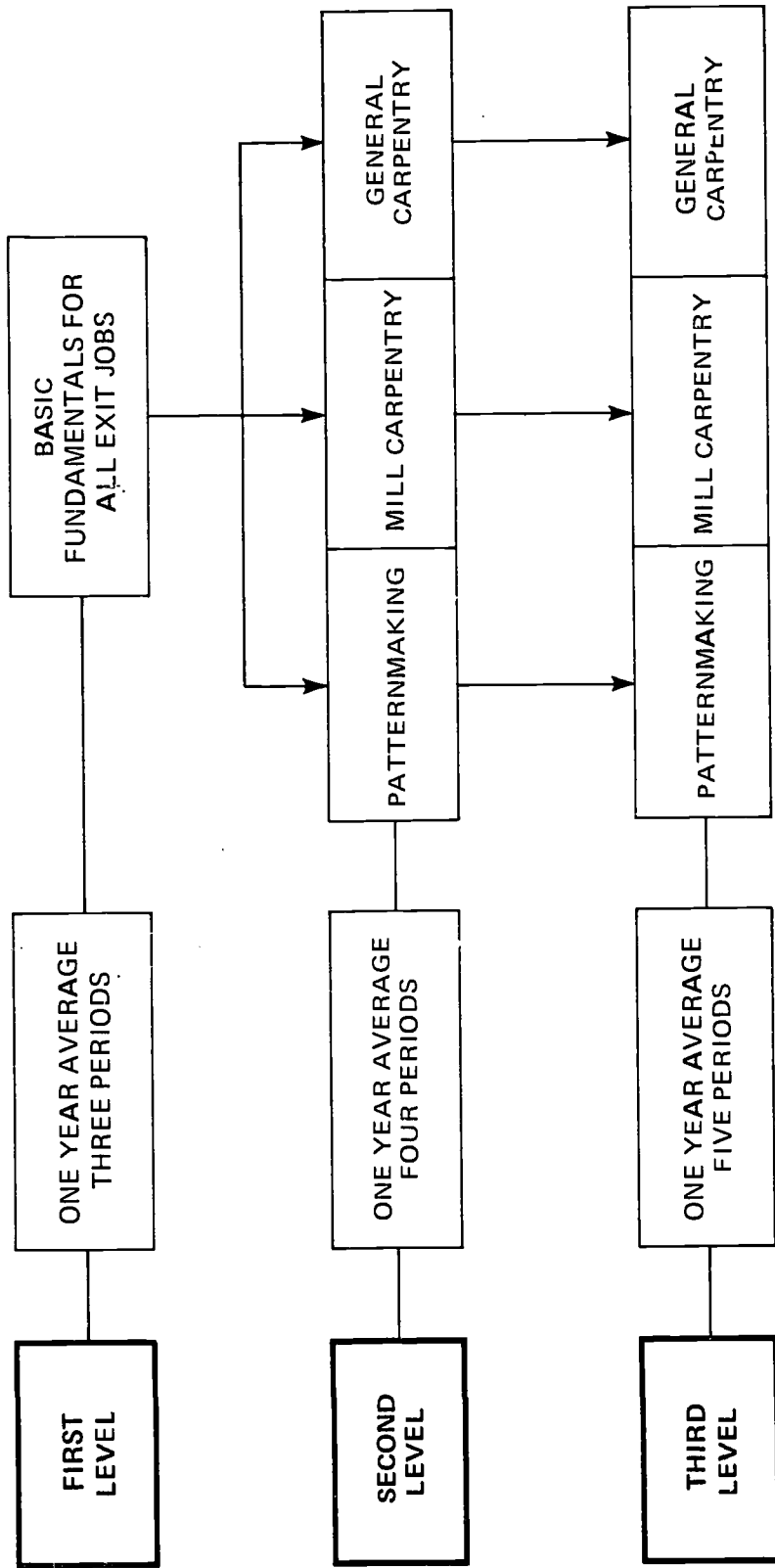

Figure 6.

DIAGRAM OF SAMPLE JOB STRUCTURE

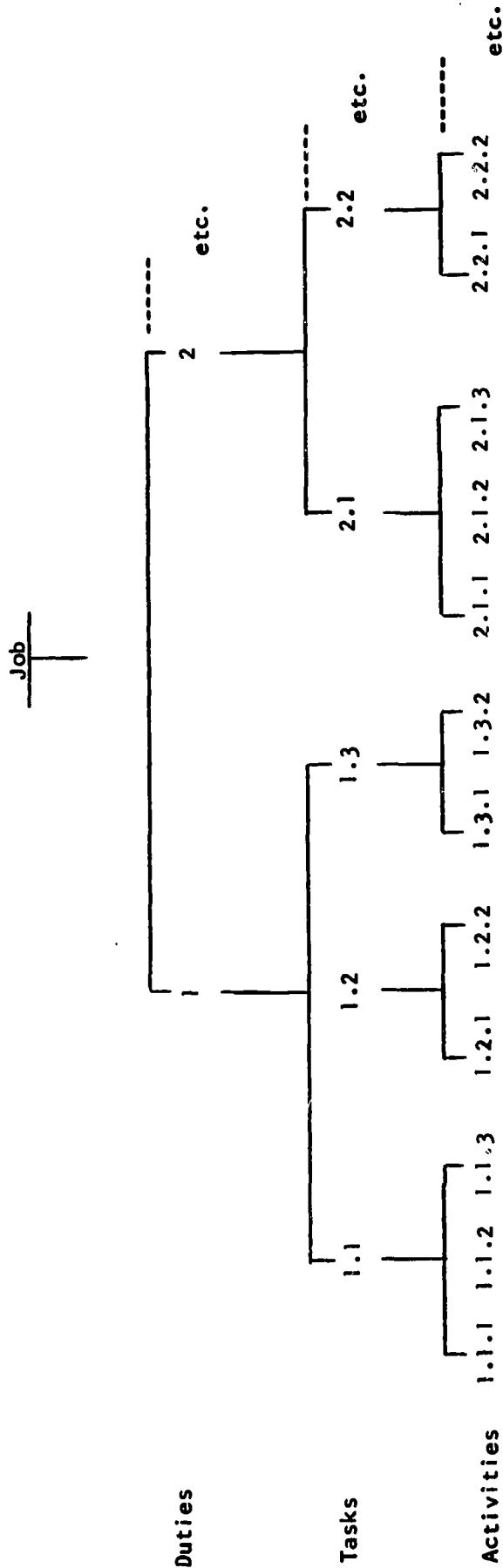

Diagram of a sample job structure showing the breakdown into duties, tasks, and activities.

Figure 7.

exit level. Students advancing to the third level programs continue to develop skills in a chosen occupation and specialty. Any student completing all three levels of a Woods program should be able to enter industry with a high degree of confidence in his ability to progress to the skilled trade and technician levels following an appropriate period of apprenticeship and advanced study. Furthermore, students mastering such training programs have proven their capability to succeed in proprietary and supervisory roles. Such persons also typically demonstrate a high success rate in two- and four-year college programs at both the technician and professional levels.

Management and Evaluation

Figure 8 illustrates many of the features of the management and evaluation of the instructional systems development process. The recently completed Fifteenth Technical Report, "Management and Evaluation Plan for Instructional Systems Development for Vocational-Technical Education," defines such activities in great detail. The Fifteenth Technical Report also includes most of the evaluation instruments, management control documents and explanations needed to develop, evaluate and field test systems such as presented in the Sixteenth Technical Report. Thus, one report compliments the other. In terms of dissemination obligations of Project ABLE and the Quincy Public Schools (primarily ES'70 network members and members of the Council of Great City Schools), persons and organizations receiving this report will have also received the Fifteenth Technical Report.

It should be noted that Project ABLE Power Mechanics and General Woodworking pilot programs (an Electronics program is also under development) were evolved concurrently with the "Management and Evaluation Plan." Here, the question of, "Which comes first-- the chicken or the egg?" has been a difficult issue for Project ABLE. Many of the problems of project management were not resolved until instructional programs were operational thus enabling various techniques and instruments to be tested and modified in an environment typical of vocational education in a public school system. (The project staff has documented in the Eighth Quarterly

PROJECT ABLE
FLOW CHART OF INSTRUCTIONAL SYSTEM DEVELOPMENT PROCESS

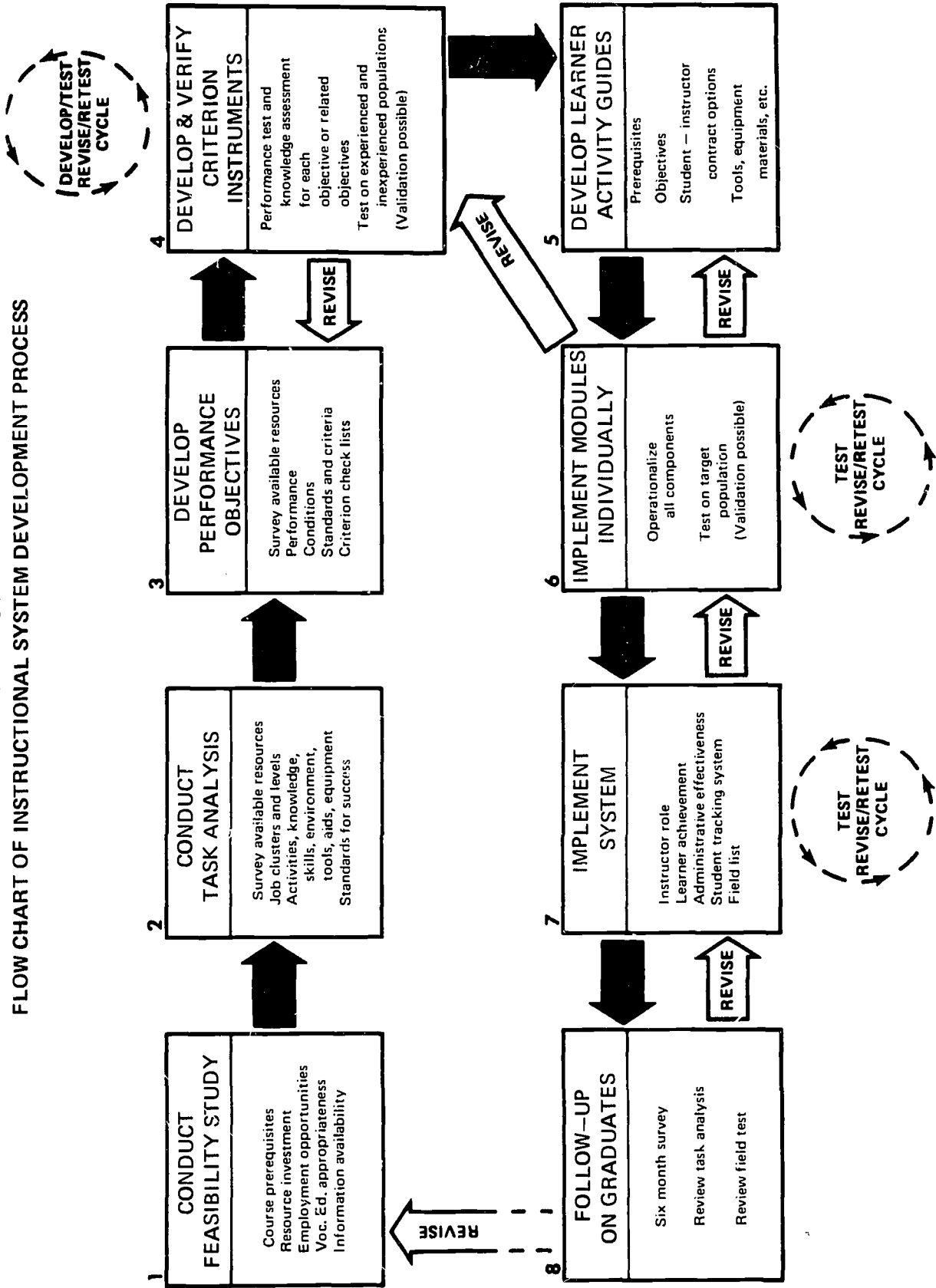

Figure 8.

Technical Report, the problems encountered in the development of experimental curricula.)

Target Population

Recent changes occurring in vocational education have altered, in some ways, the population of students to be served. In many vocational programs students have been traditionally selected on their potential to succeed at the skilled trade journeyman job level. Furthermore, much of the training offered has been limited to a rather small number of apprenticeable trade areas. However, most vocational educators, as a result of recent changes in Federal legislation, are now attempting to service a broader student population with considerably more breadth in course options. It is now recognized that training at job levels below that of the journeyman must be provided for a sizeable number of students not widely serviced in the past by vocational education. Of course, expansion is also taking place at the technician levels through a rapid proliferation of post-high school programs.

Vocational educators have frequently prepared instructional objectives for job training with standards and criteria appropriate to the experienced practitioner. Typically, three-year vocational programs have had one terminal exit point with instruction organized by content units and grade levels. Project ABLE, recognizing the national goal of servicing a more varied student population, has organized the job families by occupational levels and job tasks within those levels rather than by content units by grade levels. Important also is the fact that ABLE has prepared instructional objectives with criteria and standards pegged at ENTRY levels for each of the job segments in an occupational family hierarchy. Such methods should be more congruent with accepted theories of conditions of learning where consideration is given to prerequisite skills and knowledges in the accomplishment of higher level tasks. Furthermore, the method of job analysis should result in no grade or age level conditions or restrictions on instructional programs. Such methods are also more conducive to individualized instruction--an approach now widely advocated by educators throughout the country.

The selection of students for vocational programs (or the selection of vocational programs by the students) typically occurs during grades eight and nine. Here, guidance counselors and industrial arts teachers play an important role through referrals, suggestions, etc. It appears as though the lower ability groups among the vocational students (in terms of academic achievement and industrial arts grades), are often steered toward the Woodworking and Power Mechanics (auto body and auto mechanics) programs. In Quincy, for example, the I.Q. scores of Woods students tend to fall in the 85 to 102 range. Such characteristics are likely typical across the country. On the other hand, the ABLE Electronics programs tend to draw the "better" students and this too seems to be typical. It has been found that the Quincy vocational students, as a school group, are normally distributed on a scale of I.Q. scores with the median score above 100.

An analysis of reading requirements for the Woodworking family--blueprints, reference manuals, machine instructions, etc.--indicates a minimum reading level requirement at the sixth or seventh grade level. The tenth grade Woods students in Quincy tend to fall in the fifth to eighth grade range. Thus, for some students, remedial reading instruction will be necessary if instruction and employment at higher job levels is to be a realistic goal. In this respect, the ABLE "hands-on" approach through individualized instruction should be uniquely flexible for an integrated and concurrent program of remedial reading--especially in the terminology required for acceptable job performance and advancement. Related to the problem of student reading difficulties is the recommendation that any application of the Woods program, in urban ghetto areas or with student groups of low reading ability, be supplemented with a well designed, multi-media instructional package. Such materials would also tend to broaden the potential target population.

One characteristic of the target population observed in the Quincy programs is the pragmatic orientation of the entering students. They typically object to abstract learning activities in which no clear relationship exists to their career goals. In the

past, academic class-type work and reading assignments have created serious discipline and group control problems. If learning cannot be structured through predominately activity-type experiences, then trouble can be expected. Other group characteristics would include the probability that most students entering such programs will have had some experience in Woodworking in an industrial arts or craft class at the junior high level or through community service programs of one kind or another. Many students will have gained some experience through hobby activities and others will possess job experience in helper positions.

It should be noted that several basic assumptions, for the Quincy effort, were made of the intended target population: (1) It was expected that a majority of the trainees would be willing and able to read the blueprints, product information, catalogs, manuals, equipment instructions, etc., required for employment; (2) It was felt that student evaluation and instructional materials could be prepared to reflect the reading requirements and terminology common to each job level and therefore appropriate for the target population; (3) It was also assumed that most trainees would not leave the program at the first exit level, but would continue with many completing the second and some the third level programs; (4) Furthermore, it was assumed that most students would prefer the "hands-on" individualized self-paced program over the more traditional type class activities (typically relying on more group lectures, demonstration lessons and classroom reading assignments) and would accept slightly more reading activity in short steps as a part of the shop activity. Such assumptions have generally proved to be correct with the students in the Quincy program.

Course Organization and Strategy

The individualized learner activity process within an instructional system has been graphically illustrated in Figure 3. As can be seen, not only is the learner responsible for much of his own learning, he is also responsible for much of his own evaluation and program management. The sample Performance Evaluation Set and Learner Activity Guide included in Appendix E provides the

major vehicle for the effective management of such individualized instructional systems. Again, rather detailed explanations are offered in other ABLE documents and should not be repeated here. Note, however, the flexibility in the selection of instructional materials, media and methods. Note also, in the sample in Appendix E, the checkpoints for safety and evaluation review.

A self scoring response card, Figure 9 contributes one effective means of providing immediate "knowledge of results" for each student on various kinds of assessment items, item by item. Such aids also reduce paper work for the instructor. The Occupational Readiness Record, Figure 10, provides a means of certifying task accomplishment and summarizing information recorded on the Criterion Checklist (attached to the Learner Activity Guide and Performance Evaluation Set, Appendix E). Such assessment techniques contribute alternatives to traditional grading whereby students are compared to one another on a "curve." Thus, A-B-C-D-F letter grades have little practical value in ABLE programs. Note also, that failures are not recordable with the ABLE system. The student is certified only on those tasks (skills and knowledge) in which a minimum level of competency can be demonstrated. Some students simply take longer than others to reach the various criterion levels task-by-task and job-by-job within the occupational hierarchy. The Student Tracking System, Figure 11, is another information feedback device related to the Criterion Checklists and Occupational Readiness Record. This is a low cost, student operated mechanical system which incorporates much of the student and group guidance information available through several of the new computer supported programs. Again, the working details of such features of Project ABLE instructional systems are included in previous ABLE reports.

Determining methods of sequencing instruction has always been a problem. However, the stratification of job clusters by hierarchies alleviates some of the difficulties such as that experienced when courses are built primarily on content analyses and structured by content units. Thus, the ABLE categorization of modules or units by job tasks and job levels enables more

* TRAINER-TESTER® Self-Scoring RESPONSE CARDS

FEATURING
ALPHA/NUMERIC COMBINATION RESPONSE for **CORRECTIVE FEEDBACK**

.... IF and WHEN desired!

In addition to **HIGH-DISCRIMINATION SELF-SCORING** and **ITEM-OF-DIFFICULTY IDENTIFICATION**

VAN VALKENBURGH, NOOGER & NEVILLE, INC.

NAME NORMAN CROWDER RIGHT 23/30 WRONG

CLASS/COURSE Psych. 101 MODULE/TEST NO. 4-2 SCORE C-

DATE 8/11/70 TIME 9:00-9:20 ITEMS OF DIFFICULTY 4-6-8-10

Self-Scoring TRAINER-TESTER® Response Card

Directions—Alphabetical Response Mode: (For Alpha/Numeric response mode see Direction Sheet)
 Erase the oval where you think correct answer is. Preferably use a clean, firm abrasive pencil eraser, with a reasonably sharp edge. "T" means "right"; any other alphabetical response—"E", "H" or "L"—means "wrong". However, your instructor may designate alphabetical responses other than "T" as the correct answer responses for a particular exercise. If you uncover other than the response designated as correct, and the instructor wishes you to learn the correct answer, continue erasing until that response is revealed; make as few erasures as possible. For scoring and item-of-difficulty identification see Direction Sheet.

UNIT	ANSWER RESPONSE	SCORING POINTS	UNIT	ANSWER RESPONSE	SCORING POINTS
NUMBER	(a) (b) (c) (d)		NUMBER	(a) (b) (c) (d)	
1	a T b	3	21		
2		3	22		
3	c T d	3	23		
4		2	24		
5	e T f	3	25		
6		1	26		
7		3	27		
8		1	28		
9		3	29		
10		1	30		
11			31		
12			32		
13			33		
14			34		
15			35		
16			36		
17			37		
18			38		
19			39		
20			40		

JULY 1970 Total 23

Copyright 1966-1970 by Von Valkenburgh, Nooger & Neville, Inc.
 13 Morden Lane, New York, N. Y. 10020. All rights reserved.
 Printed in U. S. A.

U. S. Patents 2,764,626; 2,861,717; 2,866,820; 3,055,717. Patents in other English speaking and foreign language countries issued and pending. Trademark registered in U. S. and abroad (U. S. 825,625)

T-T No. Z11C Third Series

EXAMPLE OF USING ALPHA/NUMERIC RESPONSE MODE FOR CORRECTIVE FEEDBACK IN INDIVIDUALIZING INSTRUCTION

ALPHA/NUMERIC COMBINATION (Z11C and D, THIRD SERIES)

Variable-answer Response Pattern "H-E-T-L" coupled with discrete, random, Digital Response Pattern "354-676-524-720," etc. For further detail, see inside L. H. page, yellow folder X-196ac

CORRECT ANSWER DESIGNATION
 For this particular illustrative exercise, "T" has been designated the "correct" answer for immediate knowledge of results; all other letter responses are "wrong".

ALPHABETICAL RESPONSE MODE
 Upon erasure of selected answer 10(d), the alphabetical answer response "L" immediately signals the student that he is "wrong"

ALPHA/NUMERIC RESPONSE MODE
 If so desired at this point, "720" — a discrete, random, digital response — can be utilized as a discrete, controlled-access, corrective-feedback programming signal which can be coded to:

- Refer to specific text/reference material, training aids, etc., for remedial and/or further study;
- Comment tutorially on "why" the answer was wrong;
- Branch to other portions of the program;
- Etc... whatever and whenever you wish

NUMERIC RESPONSE MODE
 See Example of Use T-T-10, which utilizes Digital Programming Device Z10



TRAINER-TESTER® RESPONSE CARDS

featuring

- **HIGH-DISCRIMINATION SELF-SCORING** for Short, Frequent Tests/Quizzes
- **ITEM-OF-DIFFICULTY IDENTIFICATION** for Immediate Item Analysis

EXAMPLE OF USING HIGH-DISCRIMINATION SCORING PROCEDURE FOR A 10-QUESTION QUIZ

ITEMS-OF-DIFFICULTY...
(THOSE WITH MORE THAN ONE ERASURE) RECEIVE LESS THAN 3 POINTS-



SCORING
DONE BY STUDENTS-
NOT INSTRUCTORS

MARKS MADE BY STUDENTS ON EDGE OF CARD IDENTIFY ITEMS-OF-DIFFICULTY...

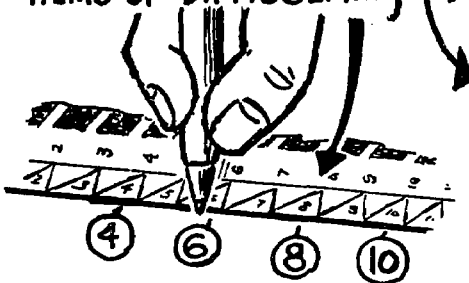

STACKING OF RESPONSE CARDS GIVES IMMEDIATE GRAPHIC ITEM ANALYSIS

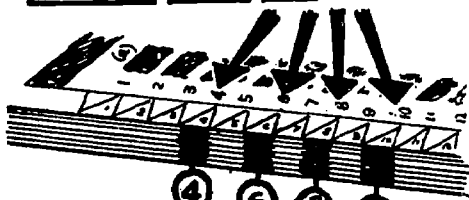

EDGE VIEW OF STACKED CARDS

VAN VALKENBURGH, NOOGER & NEVILLE, INC.

NAME NORMAN CROWDER 23/30
 CLASS COURSE EDUCATIONAL PSYCHOLOGY G-SCORE
 DATE 8/11/69 4-6-8-10

Auto-Instructional TRAINER-TESTER® Response Card

DIRECTIONS:
 Rub off the block below where you think the correct answer is. Use eraser suited to your hand. "T" means "right" any other alphabetical response—"E", "H" or "L"—means "wrong." However, for a particular exercise your instructor may choose "E", "H" or "L" instead of "T" as the correct answer. If you uncover a response differing from that designated as correct, and the instructor wishes you to learn the correct answer, continue erasing until that response is revealed; erase as little as possible. FOR ITEM OF DIFFICULTY AND SCORING SEE THE STUDENT DIRECTION SHEET.

QUESTION NUMBER	ANSWER OR TUTORIAL FEEDBACK				SCORING POINTS	QUESTION NUMBER	ANSWER OR TUTORIAL FEEDBACK				SCORING POINTS
	(a)	(b)	(c)	(d)			(a)	(b)	(c)	(d)	
1	T				3	21					
2				T	3	22					
3		T			3	23					
4			L	T	2	24					
5	T				3	25					
6		L	T	H	1	26					
7			T		3	27					
8	T	H	E		1	28					
9	T				3	29					
10		E	L	T	1	30					
11						31					
12						32					
13						33					
14						34					
15						35					
16						36					
17						37					
18						38					
19						39					
20					23	40					

© Copyright 1966-1969 by Van Valkenburgh, Nooger & Neville, Inc. U.S. Patents 2,784,821, 2,881,172, 2,888,820, 3,051,117 Patents in other English-speaking and foreign language countries issued and pending. Trademark registered in U.S. and abroad (U.S. 625,025). Printed in U.S.A. **T-T No. Z-11** Second Series

COMMENTS

OCCUPATIONAL READINESS RECORD

TO THE EMPLOYER:

This occupational readiness record is both an instructional tool and a learning course content and level of proficiency or achievement. It is demonstrated by the graduate. Graduates can provide potential employers with more complete performance check lists which identify in great detail the skills and knowledge in which he has demonstrated proficiency. It is recognized that persons working at the specific occupational level will function with direction and assistance from supervisors as part of the training, the graduate's task. Furthermore, graduates should be provided with a job description that backs the authority and training to perform certain functions and operations. He will expect and seek supervision, assistance and direction where appropriate. Note that the job tasks as identified are basic to the next higher or more sophisticated job level. Work experience and further training may qualify the graduate for more complicated tasks, a new job title, and higher pay.

KEY TO PROFICIENCY CODE:

Level L: Limited Skill—does simple parts of task using required tools but requires instruction and supervision to do most parts of the job. Identifies parts by name, knows simple facts about the job.
 Level M: Moderate Skill—requires help on some parts, but can use most tools and special equipment needed. Knows work procedures but may not meet minimum demands for speed or accuracy.
 Level S: Skilled—understands operating principles and accomplishes all parts of task with only spot checks of finished work. Meets minimum demands for speed and accuracy.

All graduates receiving this document have satisfactorily demonstrated to the training staff their ability to work safely, understand and carry out instructions, and cooperate with other employees. This document also attests to their punctuality, reliability, and general work habits.

Project AEL/Quincy Public Schools/American Institutes for Research

BEST AVAILABLE COPY

JOB FAMILY: Woodworker and Related Occupations
 EXIT LEVEL: Millman Apprentice (Dot 669.380) and Related Occupations

OCCUPATIONAL READINESS RECORD

PROJECTABLE

Name _____
 Soc. Sec. No. _____ Date _____
 Length of Training _____
 Certified by _____ Director
 School _____
 Address _____

PERMISSION TO REPRODUCE THIS COPY-RIGHTED MATERIAL HAS BEEN GRANTED BY *Eric D. ...* TO ERIC AND ORGANIZATIONS OPERATING UNDER AGREEMENTS WITH THE U.S. OFFICE OF EDUCATION. FURTHER REPRODUCTION OUTSIDE THE ERIC SYSTEM REQUIRES THE MISSION OF THE COPYRIGHT OWNER.

JOB FAMILY: Woodworker and Related Occupations EXIT LEVEL: Millman Apprentice (Dot 669.380) and Related Occupations	
Name _____ Date _____	Length of Training _____ Title _____
LMS	Comments
<input type="checkbox"/>	Observes shop safety.
<input type="checkbox"/>	Measures angles.
<input type="checkbox"/>	Makes stock list.
<input type="checkbox"/>	Makes isometric sketches.
<input type="checkbox"/>	Makes multiview drawings.
<input type="checkbox"/>	Reads blueprints.
<input type="checkbox"/>	Identifies handtools.
<input type="checkbox"/>	Assembles jobs using hammer and nails.
<input type="checkbox"/>	Assembles jobs using screwdriver and screws.
<input type="checkbox"/>	Constructs components with handtools.
<input type="checkbox"/>	Drills and countersinks using handdrill.
<input type="checkbox"/>	Checks surfaces and lays out lines using straightedge.
<input type="checkbox"/>	Sharpens tools and planes.
<input type="checkbox"/>	Identifies and classifies lumber.
<input type="checkbox"/>	Cuts angles and bevels on a circular saw.
<input type="checkbox"/>	Cuts dados and rabbets on a circular saw.
<input type="checkbox"/>	Drills holes and routs on a drill press.
<input type="checkbox"/>	Curnes irregular shapes with chisels and gouges.
<input type="checkbox"/>	Prepares stock with circular saw, surface planer, sander, mortiser and drill press.

LMS	<input type="checkbox"/>	Sands work smooth with abrasive paper.
<input type="checkbox"/>	<input type="checkbox"/>	Makes mortise and tenon joints with miter and circular saw.
<input type="checkbox"/>	<input type="checkbox"/>	Assembles drawer frames with clamps.
<input type="checkbox"/>	<input type="checkbox"/>	Glues lumber to width and thickness.
<input type="checkbox"/>	<input type="checkbox"/>	Dresses stock to size using hand planes and other handtools.
<input type="checkbox"/>	<input type="checkbox"/>	Computes areas.
<input type="checkbox"/>	<input type="checkbox"/>	Computes board feet.
<input type="checkbox"/>	<input type="checkbox"/>	Computes time and materials.
<input type="checkbox"/>	<input type="checkbox"/>	Cuts stock to length and width using hand saws.
<input type="checkbox"/>	<input type="checkbox"/>	Makes layouts of components and assemblies with layout tools.
<input type="checkbox"/>	<input type="checkbox"/>	Constructs rails, aprons, and stretchers using wood milling machines.
<input type="checkbox"/>	<input type="checkbox"/>	Makes and uses templates.
LMS	<input type="checkbox"/>	Lays out accurate dimensions using knife, square, and scribe.
<input type="checkbox"/>	<input type="checkbox"/>	Measures dimensions to 1/32 and 1/64 using scales and rulers.
<input type="checkbox"/>	<input type="checkbox"/>	Lays out geometric constructions.
<input type="checkbox"/>	<input type="checkbox"/>	Scrapes wood surfaces using scrapers.
<input type="checkbox"/>	<input type="checkbox"/>	Turns stock to shape and size on a lathe.
<input type="checkbox"/>	<input type="checkbox"/>	Constructs drawers.
<input type="checkbox"/>	<input type="checkbox"/>	Cuts dovetails with router and drill press.
<input type="checkbox"/>	<input type="checkbox"/>	Cuts and fits panels with power tools.
<input type="checkbox"/>	<input type="checkbox"/>	Turns on a faceplate on a lathe.
<input type="checkbox"/>	<input type="checkbox"/>	Makes miter joints on a miter box.
<input type="checkbox"/>	<input type="checkbox"/>	Constructs drawer dividers and inserts with power routers.
<input type="checkbox"/>	<input type="checkbox"/>	Turns fine detail shapes on a lathe.
<input type="checkbox"/>	<input type="checkbox"/>	Prepares surfaces for finishing using abrasives and cleaning solvents.

LMS	<input type="checkbox"/>	Sets components in place with chisels and gouges.
<input type="checkbox"/>	<input type="checkbox"/>	Applies stain using rags and brushes.
<input type="checkbox"/>	<input type="checkbox"/>	Applies sealers using a sprayer and/or brush.
<input type="checkbox"/>	<input type="checkbox"/>	Poliates finished surfaces using pumice and oil.
LMS	<input type="checkbox"/>	Inserts and fastens hardware using drill and screwdriver.
<input type="checkbox"/>	<input type="checkbox"/>	Identifies sizes and types of fasteners using gauges and charts.
<input type="checkbox"/>	<input type="checkbox"/>	Uses woodglue and flat bottom bits to cover screwheads.

The trainee has had limited experience in dispensing, receiving credit and cash payments, and keeping records and inventory. On-the-job training required in these and other areas.

operational flexibility. It is interesting to note that many of the tasks within a specific job level need not precede or follow one another. Here, it is expected that the instructor and students will take advantage of such flexibility in the individualization of learner activity. Thus, sequence of task accomplishment should be structured, wherever possible, on the basis of individual student needs. For example, those students involved in cooperative work-study programs or working at related part-time jobs should select instructional activities to precede or coincide with their occupational activity.

Instructional strategy in the ABLE programs has been molded by the heavy emphasis on activity kinds of experiences through "hands-on" learning and assessment. This is a situation in which realistic job performance activity is provided. The program, then, is built around laboratory or shop work in which the student handles the tools, equipment or materials with which he must gain proficiency or operates under the conditions (simulation possible) and in an environment similar to the one he has selected for future employment. Classroom lectures, classroom reading assignments and large group demonstrations are eliminated wherever possible. Where instructional modules have been developed, reading has been broken into short steps and integrated into the laboratory activity. Training aids and devices, simulations, mock-ups, etc., play an important role in all aspects of the program (see Figure 12). With the focus of learning activity in the laboratory, study carrels and audio-visual equipment become as much a part of the area as are the benches, machines and the other training aids and devices.

One way of organizing a manageable program to enable individual accomplishment of major training objectives is to identify a typical product or project which incorporates most of the required job tasks. Here, a mass production project in which a saleable product can be acquired is a well accepted technique among vocational educators and has been successfully used in the ABLE Woods program. Interchangeable parts built to specification provides one means of working to industrial standards with an

application of quality control procedures. Reinforcement and practice of such learning, while integrated into all such activity, is greatly dependent upon: continuation in a second level program; cooperative work-study programs; and the anticipated early use of job skills and knowledge possible because of the means of structuring the program by job levels in the hierarchy of skills and knowledges. Of course, some students will require more time and effort (study and practice) to accomplish various basic job task requirements--both during the term of the first level training activity and the following higher level instructional programs or on-the-job activity.

Most vocational schools offering Woods programs similar to that provided in Quincy will likely find a portion of the students enrolled in the Woods area afflicted with various reading problems. In the Quincy program, several students, although maintaining a satisfactory rate of progress, did experience difficulties with the required reference and assessment materials. Special assistance must be provided for such persons and this can be accomplished in many ways in a flexible program of individualized instruction. However, the research staff of ABLE strongly feel that multi-media support materials must be developed. This will be essential if the program is to be of any value for the large number of students with special needs. (Of course, the Federal government has established national priorities in the servicing of disadvantaged students and those with special needs.) Film loops, such as those listed in Appendix G will be of help. However, other kinds of devices and techniques will be necessary for an ABLE-type program where heavy emphasis is placed on individual student performance assessment and job task certification.

The design of toolroom and storage facilities has been strongly influenced by the problems of pilferage and equipment security. Experience gained during the initial testing of the ABLE Woods program showed a considerable saving in small tool and supply purchases through the use of individual student tool kits and storage compartments. Vocational educators have found many ways of dealing with such problems, and as in Quincy, some methods

are more effective than others depending on the conditions at hand. For the convenience of school systems electing to field test the ABLE Woods program, equipment lists with estimated costs are included in Appendix G. The storage of Learner Activity Guides and Performance Evaluation Sets, self-scoring response cards, Occupational Readiness Record cards and other materials will require a lockable file drawer cabinet. The cabinet should be centrally located in the shop for ease of instructor access while maintaining visual control of students.

More detailed explanations on implementation, field testing, instructor duties and performance, research data and information collection, shop and course organization, and other essential information including teacher training and inservice training, are presented in the Fifteenth Technical Report.

Initial Testing and Validation

Initial project development was undertaken in January 1965. With the opening of school in the fall of 1965, some preliminary work in the Woodworking job family was underway. Generally, this could be described as the feasibility study phase in which the employment outlook, pay potential, appropriateness for training, available information and other factors were analyzed. By the end of 1968, considerable work had been completed in the job family analyses. This was accomplished utilizing part-time staff. Several documents, including the behaviorally stated performance objectives (Appendix C and D) and the Occupational Analyses (Appendix B) were completed during that time.

The method of job and task analysis and validation of objectives included a variety of accepted techniques. A general review of literature with assistance from the Department of Labor and the Massachusetts State Employment Service produced much of the available information and data on most of the job families under investigation by ABLE, including the General Woodworking clusters. Simulated methods of task analysis, which trade experienced persons performed job tasks under observation along with various interview techniques, were applied depending on the job or job tasks being analyzed. Results were submitted to a re-

view panel which included an advisory group of trade and industrial experts which served the vocational school (one for each of the major job families) in a consulting role. The list of behaviorally stated objectives for the core program was again subjected to verification with the testing of the Woods program during the 1969-70 school year. It should be noted that fully operational programs in the Woods family exist only at the basic or core first level. The advanced second and third level programs have only the performance objectives available for instructor use. This is not considered adequate to meet the overall project objectives which include the individualization of instruction and the application of advanced instructional technology to the conduct of vocational programs.

The first full tests of the Woods curriculum, during the second semester of the 1967-68 school year, used only the behavioral objectives and brief instructor guide sheets in the structuring of learning activity. The approach was found to be quite inadequate with few innovative changes taking place in terms of student and instructor behavior and method of operation. During the 1968-69 school year, a highly structured and sequenced course utilizing linear type of step-by-step programs was attempted. Each student was required to work with the newly developed self-paced set of instructional modules. The variation of student activity came about primarily as a result of variance in rate of progress. Most of the learning and assessment activity involved simulated task practice utilizing test blocks, practice materials and similar devices. No projects or products were included in the initial test of the basic skill training program. Much reading was required in order for the student to follow step-by-step each of the operations to be performed. Paper work for both students and teacher became time consuming. It was observed that many of the fragmented skill training activities could not be related by the students to their career goals. Needless to say, many problems arose. Only 8 of 26 students completed the core program job tasks.

For the 1969-70 school year, many of the techniques reported

in the Twelfth Quarterly Technical Report on the Power Mechanics Curriculum were applied to the General Woodworking program. Criterion instruments (performance tests) and learner activity guide sheets were developed and implemented on a trial basis. A group mass production project was initiated which enabled a more flexible activity oriented program. More attention was given to the relationship of class activities to future job and employment requirements. Furthermore, the structure provided a vehicle for testing, on a module-by-module basis, the Performance Evaluation Sets and Learner Activity Guides such as that included in Appendix E. By the end of the 1969-70 school year, all such modules had been through the test/revise/retest cycles and were ready for final typing during the summer of 1970. Figure 13 depicts a situation in which a performance evaluation is taking place.

At the end of the first semester in January 1970, the following comparison was made and reported in the Monthly Progress Letter to USOE.

General Woodworking, First Level	First Semester	
	Sept. 1968 to Jan. 1969 (26 students)	Sept. 1969 to Jan. 1970 (27 students)
Average number of tasks practiced by the top 1/3 of the class	21	45
Average number of behavioral objectives achieved by the top 1/3 of the class	35	72
Individual projects completed--entire group	2	20
Discipline problems handled and recorded--entire group	35	5

By the end of the school year (June 1970) only four students in two basic Woods classes totaling 27 students, had not completed all of the required job tasks for first level certification. Several students had advanced to the second level program by February and March. It is interesting to note that the four students not

completing the first level program have reelected Woods for the 1970-71 school year. In doing so, the four have agreed to complete all first level tasks before moving into advanced work. Thus, graduation to advanced tasks and second level learning activity in the hierarchy of the Woods job family began in February 1970 and will likely continue through September or October 1970. All but four of the students in the basic program acquired saleable job skills by the end of their tenth school year (with the four slower students likely to achieve such a level by the early months of their eleventh grade program). All but one of the students completing the basic program elected to continue advanced level training in the Woods family.

During the course of the school year, three students left the program. The reasons as recorded by the guidance department were as follows: One student moved to another city; the other two are considered dropouts from school. However, one of those two students secured employment in a woodworking occupation.

Advance registration for the 1970-71 school year indicates an 85% increase in enrollment in the Basic Woods course. This compares to an overall rate of increase in enrollment of 45% for the vocational school across all job family areas. Other information comparing ABLE and non-ABLE students on dropout rates, absenteeism, recorded discipline problems and other factors will be compiled for inclusion in the final project report. However, the Woods program can be considered in the formative stages of development. Therefore, until adequate field testing has been accomplished, extensive statistical analyses and experimental-control group comparisons would not be appropriate.

Samples of the evaluation instruments used in the early testing of the Woods curriculum can be found in the Twelfth Quarterly Technical Report. The revised instruments, management control documents, and general procedures are, however, presented in the Fifteenth Technical Report. It should be noted here that the Management and Evaluation Plan was tested and revised concurrently with the extensive changes undertaken in the Woods and Power Mechanics curricula.

RECOMMENDATIONS

1. Dissemination of this report should be undertaken among the members of the Council of Great City Schools and among the members of the ES'70 network.
2. Dissemination of the Performance Evaluation Sets and Learner Activity Guides for the General Woodworking Core curriculum should be undertaken among the Council and ES'70 members.
3. A preliminary evaluation should be secured on this report and on the Woods curriculum materials from the Council and ES'70 members. Here, a review by content and curriculum experts, teachers and administrators from the various systems would be most valuable.
4. Working agreements for the field testing of the Woods instructional system should be established among those Council and ES'70 members wishing to cooperate with Quincy and AIR in such activities. Here, an appropriate evaluation will require a test population of adequate size. Furthermore, a broader distribution in terms of student population and geographic location than that possible in one vocational school will be required if validity and reliability of test results are to be assured. The proposed experimental field test programs should be considered pilot demonstration projects with the additional objectives of acquainting school instructors and administrators with instructional systems of the type described in this report. The proposed programs should also serve the function of training local school staff in the procedures of developing, implementing and evaluating systematized programs of individualized instruction. Inservice training in the process of individualizing instruction should be initiated and carried through. Every effort should be made to establish such pilot programs as exemplary demonstration models. This means equipping with appropriate audio-visual materials and equipment, training aids, references, furniture and shop equipment.

5. Implementation and evaluation of the proposed field testing of the Woods system should follow precisely the procedures established through ABLE research (and reported in the Fifteenth Technical Report).
6. Reactivation of development of the second and third level Woods curricula should be undertaken. (Much development has been completed in such areas as can be seen from the documents included in the appendices. However, activity has been curtailed due to problems of funding and project continuation.)

SELECTED REFERENCES

(NOTE: References are listed by the sections shown below. However, references are listed under one section only. This was done even though several such publications could appropriately have been included in two or more of the subject groupings.)

PROJECT ABLE

INDIVIDUALIZED INSTRUCTION

FEASIBILITY STUDIES

JOB ANALYSIS: TASK DESCRIPTION AND TASK ANALYSIS

ALLOCATION OF TRAINING

INSTRUCTIONAL OBJECTIVES

PROFICIENCY MEASUREMENT AND CRITERION REFERENCED ASSESSMENT

SYSTEMS ANALYSIS AND APPROACH TO INSTRUCTIONAL SYSTEMS
DEVELOPMENT

FORMATIVE AND SUMMATIVE CURRICULUM EVALUATION

PROJECT ABLE

- American Institutes for Research. An Experimental Program. Development and Evaluation of an Experimental Curriculum for the New Quincy (Mass.) Vocational-Technical School. Pittsburgh: Institutes for Performance Technology, November 1964.
- American Institutes for Research. Development and Evaluation of an Experimental Curriculum for the New Quincy (Mass.) Vocational-Technical School. Pittsburgh: Institute for Performance Technology:
- First quarterly technical report, June 1965. Morrison, E. J.
- Second quarterly technical report, The Problem of Defining Objectives, September 1965. Morrison, E. J.
- Third quarterly technical report, Curriculum Implications of the Study of Objectives, December 1965. Gagne, R. M. and Morrison, E. J.
- Fifth quarterly technical report, The Roles, Characteristics, and Development Procedures for Measurement of Individual Achievement, June 1966. Lecznar, W. B. and Morrison, E. J.
- Sixth quarterly technical report, The Development of Learning Units, September 1966. Lecznar, W. B. and Morrison, E. J.
- Seventh quarterly technical report, The Sequencing of Learning Units, December 1966. Lecznar, W. B. and Morrison, E. J.
- Eighth quarterly technical report, Problems Relating to the Development and Implementation of a Vocational Curriculum, March 1967. Butler, F. C., Hudak, V. M.
- Eleventh quarterly technical report, The Electronics Curriculum, January 1969. Butler, F. C. and Crozier, P. W.
- Twelfth quarterly technical report, The Power Mechanics Curriculum, July 1969. Ullery, J. W. and Forsyth, R. W.
- Leporini, F., Neifing, G., and Ullery, J. W. General Woodworking Core Curriculum, Project ABLE Sixteenth Technical Report. Pittsburgh: American Institutes for Research, July 1970.
- Ullery, J. W. Project ABLE: Progress Report. Paper presented at the 63rd annual American Vocational Association Convention, Boston, December, 1969.
- Ullery, J. W. Management and Evaluation Plan for Instructional Systems Development for Vocational-Technical Education. Project ABLE Fifteenth Technical Report. Pittsburgh: American Institutes for Research, April, 1970.

INDIVIDUALIZED INSTRUCTION

- American Institutes for Research. Talent + Plan = A New Humanism. Reprint from Greater Pittsburgh Magazine, September 1967.
- Brown, J. W. and Norberg, M. D. Administering Educational Media. New York: McGraw-Hill, 1965.

- Gagné, R. M. The Conditions of Learning, New York: Holt, Rinehart, & Winston, 1965 (a).
- Gagné, R. M. (Ed.) Learning and Individual Differences. Columbus: Charles E. Merrill, 1967.
- Gagné, R. M. Curriculum Research and the Promotion of Learning. In Tyler, R. W., Gagne, R. M. and Scriven, M. Perspectives of Curriculum Evaluation. AERA monograph series, Chicago: Rand McNally, 1967.
- Glaser, R. L. The Program for Individually Prescribed Instruction. Paper read at the annual meeting of the American Educational Research Association, Chicago, February 1966.
- Henry, N. B. (Ed.) Individualizing Instruction. 61st Yearbook of the National Society for the Study of Education. University of Chicago Press, 1962.
- Mager, Robert F. and McCann, J. Learner-Controlled Instruction. Palo Alto, California: Varian Associates, 1961.
- Meierberry, Wesley, C. (Ed.) Learning Theory and Audio-Visual Utilization. Audio-Visual Communications Review. Vol. 9. Supplement 4. September, October 1961.
- Postlethwait, S. N. and others. An Integrated Approach to Learning: With Emphasis on Independent Study. Minneapolis, Minnesota: Burgess Publishing Company, 1964.
- Rahmlow, Harold F. Use of Student Performance Data for Improvement of Individualized Instructional Materials. Paper read at the American Psychological Association meeting in Washington, D.C., September 1969.

FEASIBILITY STUDIES

- Altman, J. W. Research on General Vocational Capabilities (Skills and Knowledges). Pittsburgh: American Institutes for Research, March 1966.
- Altman, J. W. and Morrison, E. J. School and Community Factors in Employment Success of Trade and Industry Course Graduates. Pittsburgh: American Institutes for Research, August 1966.
- Arnold, Walter M. Statewide Planning Studies: Pennsylvania. Paper read at American Vocational Association Annual Convention, December 1969.
- Eninger, M. U. The Process and Product of T&I High School Level Vocational Education in the United States. Pittsburgh: American Institutes for Research, September 1965.

Gagné, R. M. Methods of Forecasting Maintenance Job Requirements, in Symposium on Electronics Maintenance, Report PPT 202/4, Advisory Panel on Personnel and Training Research, Office of the Assistant Secretary of Defense, Research and Development, Washington, August 1955, pp. 47-522.

Rosenfeld, M., Kowal, B., and Seiler, E. L. Assessing the Progress of Education: Vocational Education--Phase I. Pittsburgh: American Institutes for Research, November 1965.

Rosenfeld, Michael. An Evaluation Plan for the Greene Joint Vocational School. Pittsburgh: American Institutes for Research, 1967.

Schill, W. J. Curriculum Content for Technical Education. Cooperative Research Project No. 2048. University of Illinois. Urbana, Illinois, 1964.

Schill, W. J. and Arnold, J. P. Curricula Content for Six Technologies. University of Illinois. Urbana, Illinois: Bureau of Educational Research, 1965.

Warmbrod, J. R. Review and Synthesis of Research on the Economics of Vocational-Technical Education. Columbus, Ohio: ERIC Clearing House. The Center for Vocational and Technical Education, Ohio State University, November 1968.

JOB ANALYSIS: TASK DESCRIPTION AND TASK ANALYSIS

Bryan, G. L. Empirical Evaluation of Various Job-Analysis Methods in Symposium on Electronics Maintenance, Report PPT 202/4, Advisory Panel on Personnel and Training Research, Office of the Assistant Secretary of Defense, Research and Development, Washington, August 1955, pp. 35-46.

Gustafson, H. W., Honsberger, W. D., and Michelson, S. Determination of Task Analysis Content in Uses of Task Analysis in Deriving Training and Training Equipment Requirements, Technical Report 60-593, Behavioral Sciences Laboratory, Aerospace Medical Laboratory, Wright-Patterson AFB, Ohio, December 1960, pp. 5-10.

Jones, Edna M., and Fairman, Jean B. Identification and Analysis of Human Performance Requirements, in Human Factors Methods for System Design, John D. Folley, Jr. (ed.), The American Institute for Research, Pittsburgh, 1960, pp. 43-62.

Kershner, Alan M. A Report on Job Analysis, ONR Report ACR-5, Office of Naval Research, Department of the Navy, Washington, 1955, 72 pp.

- Miller, R. B. Analysis and Specification of Behavior for Training, in Training Research and Education, Robert Glaser (ed.), University of Pittsburgh Press, Pittsburgh, 1962, pp. 31-62.
- Miller, R. B. A Method for Man-Machine Task Analysis, Technical Report 53-137, Aero Medical Laboratory, Wright Air Development Center, Wright-Patterson AFB, Ohio, June 1953, pp. 60.
- Miller, R. B. A Suggested Guide to Position-Task Description, Technical Memorandum ASPRL-TM-56-6, Armament Systems Personnel Research Laboratory, Air Force Personnel and Training Research Center, Air Research and Development Command, Lowry AFB, Colorado, April 1956; reprinted May 1960, pp. 39.
- Miller, R. B. Task Description and Analysis. In Gagne, R. M. (Ed.), Psychological Principles in System Development. New York: Holt, Rinehart, & Winston, 1962.
- Morsh, J. E., Madden, Maj. J. M., and Christal, R. E. Job Analysis in the United States Air Force, Technical Report 61-113, Personnel Laboratory, Wright Air Development Division, Air Research and Development Command, Lackland AFB, Texas, February 1961, pp. 37 plus Apps.
- Rupe, J. C. Research Into Basic Methods and Techniques of Air Force Job Analysis-I, Technical Report 52-16, Research and Development Group (Technical Training Research Laboratory), Human Resources Research Center, Air Training Command, Chanute AFB, Ill., December 1952, pp. 68.
- Rupe, J. C. Research Into Basic Methods and Techniques of Air Force Job Analysis-IV, Research Report AFPTRC-TN-56-51, Training Aids Research Laboratory, Air Force Personnel and Training Research Center, Air Research and Development Command, Chanute AFB, Ill., April 1956, pp. 49.
- Rupe, J. C., and Weston, Risdon J. Research into Basic Methods and Techniques of Air Force Job Analysis--II, Research Report AFPTRC-TN-55-51, Training Aids Research Laboratory, Air Force Personnel and Training Research Center, Air Research and Development Command, Chanute AFB, Ill., November 1956, pp. 66 plus Apps.
- Rupe, J. C. and Westen, Risdon J. Research into Basic Methods and Techniques of Air Force Job Analysis-III, Research Report AFPTRC-TN-55-53, Training Aids Research Laboratory, Air Force Personnel and Training Research Center, Air Research and Development Command, Chanute AFB, Ill., December 1955, pp. 67 plus Apps.

Snyder, M. B. Methods of Recording and Reporting Task Analysis Information, in Uses of Task Analysis in Deriving Training and Training Equipment Requirements, Technical Report 60-593, Behavioral Sciences Laboratory, Aerospace Medical Laboratory, Wright-Patterson AFB, Ohio, December 1960, pp. 11-31.

ALLOCATION OF TRAINING (Whether a task should be taught and level to which it should be taught.)

American Institutes for Research. Maintenance Technicians Performance Curves (Monthly Status Report #14) Pittsburgh, November 1969.

Flanagan, J. C. The Critical Incidence Technique. Psychological Bulletin, 51, 327-358.

Gagne, R. M. Human Functions in Systems, In Psychological Principles in System Development, Robert M. Gagne (Ed.), Holt, Rinehart and Winston, New York, 1962, pp. 35-73.

Gagne, R. M. The Acquisition of Knowledge, Psychol, Review, Volume 69, No. 4, July 1962, pp. 355-365.

Jones, E. M. and Fairman, J. B. Identification and Analysis of Human Performance Requirements, In Human Factors Methods for System Design, John D. Folley, Jr. (Ed.), The American Institute for Research, Pittsburgh, 1960, pp. 43-62.

Miller, R. B. and Van Cott, H. P. The Determination of Knowledge Content for Complex Man-Machine Jobs, The American Institute for Research, Pittsburgh, December 1955, pp. 49 plus Apps.

INSTRUCTIONAL OBJECTIVES

Baker, Eva. Establishing Performance Standards. Los Angeles: Vimcet Associates, 1966.

Briggs, L. J. Sequencing of Instruction in Relation to Hierarchies of Competence. Palo Alto, California: American Institutes for Research, October 1967.

Gagné, R. M. The Analysis of Instructional Objectives for the Design of Instruction. In Glaser, R. (Ed.) Teaching Machines and Programmed Learning. II: Data and Directions. Washington, D.C., National Education Association, 1965, 21-65 (a).

Gagné, R. M. Educational Objectives and Human Performance. In Learning and the Educational Process, Krumboltz, J. D. (ed.), Chicago, Rand McNally, 1965 (b).

Gerlach, V. S. and Sullivan, H. J. Constructing Statements of Outcomes. Inglewood, California: Southwest Regional Laboratory for Educational Research and Development, 1967.

Harrison, G. V. The Instructional Value of Presenting Explicit Versus Vague Objectives. Wilson, J. A. R. (Ed.) California Educational Research Studies, University of California, Santa Barbara, 1967.

Mager, R. B. Preparing Objectives for Programmed Instructors. San Francisco: Tearon Publication (1962)

Popham, W. J. Objectives of Instruction. In Popham, W. J., Eisner, E. W., Sullivan, H. J. and Tyler, L. L. Instructional Objectives. AERA monograph series on curriculum evaluation, No. 3, Chicago: Rand McNally, 1969.

Sullivan, H. J. Objectives, Evaluation, and Improved Learner Achievement. In Popham, W. J., Eisner, E. W., Sullivan, H. J., and Tyler, L. L. Instructional Objectives, AERA monograph series on curriculum evaluation, No. 3. Chicago: Rand McNally, 1969.

PROFICIENCY MEASUREMENT AND CRITERION REFERENCED ASSESSMENT

Astin, Alexander W. Criterion-Centered Research. Educational and Psychological Measurement, No. 24, 807-822.

DuBois, Philip H., Teel, K. S., and Petersen, R. L. On the Validity of Proficiency Tests, Educ. Psychol. Measmt, Vol. 14, No. 4, Winter 1954, pp. 605-616.

Foley, John P., Jr. Performance Testing: Testing for What Is Real, AMRL Memorandum P-42, 6570th Aerospace Medical Research Laboratories, Aerospace Medical Division, Wright-Patterson AFB, Ohio, June 1963, pp. 18.

Frederiksen, N. Proficiency Tests for Training Evaluation. In Glaser, R. (Ed.), Training Research and Education. Pittsburgh: University of Pittsburgh Press, 1962.

Fredricksen, N. Proficiency Tests for Training Evaluation, In Psychological Research in Training and Education, Robert Glaser (Ed.), University of Pittsburgh Press, Pittsburgh, 1961, pp. 323-346.

Gagné, R. M. Training Devices and Simulators: Some Research Issues, Amer. Psychologist, Vol. 9, No. 3, March 1954, pp. 95-107.

Gagné, R. M. and Paradise, Noel E. Abilities and Learning Sets In Knowledge Acquisition, Psychol. Monogr., Vol 75, No. 14 (whole no. 518), 1961, pp. 23.

APPENDIX A

JOB TITLE ENUMERATION

JOB TITLE ENUMERATION

THE GENERAL WOODWORKING CORE CURRICULUM

<u>JOB NAME</u> (Carpentry)	<u>SELECT</u>		<u>REASON</u>
	<u>Yes</u>	<u>No</u>	
Cribber	/		
Roofer	/		
Framer (light)	/		
Finishman	/		
Shorer		/	#2
Stage carpenter		/	#2
Wooden tank carpenter		/	#2
Display carpenter		/	#2
Tileman	/		
Painter	/		
Bank carpenter		/	#2
Welder		/	#3
Hotel carpenter		/	#2
Maintenance carpenter		/	#5
Bench carpenter		/	#5
Mold carpenter		/	#2
Millman	/		
Diver		/	#3
Accoustical carpenter		/	#2
Wood sawyer		/	#2
Wallboard carpenter	/		
Wood technologist		/	#3
Box maker		/	
Flask carpenter	/		
Sash and frame carpenter		/	
Door hanger		/	#3
Stair builder		/	
Store fixture carpenter		/	
Hardware inserter		/	
Floor sander		/	#2
Ship carpenter		/	
Carpenter's helper		/	
Refrigerator carpenter		/	#3
Set-up man		/	#3
Tool grinder		/	#3
Bridge carpenter		/	
Cabinet installer	/		
Estimator		/	#5
Church carpenter		/	#3
Glazer		/	
Boat builder	/		
(a) Layout	/		
(b) Framer	/		
(c) Planker	/		
(d) Finish man	/		
(e) Painter	/		
Circular saw operator		/	#3
Cut off saw operator		/	#3
Jointer machine operator		/	#3

JOB NAME (Carpentry)	SELECT		REASON
	Yes	No	
Surface plane operator		/	#3
Bandsaw operator		/	#3
Siding applicator	/		
Trench bracer		/	
Bit sharpener		/	#2
Boat oar maker		/	#2 & 3
Bench carpenter		/	#9
Check grader		/	#2
Dry lumber grader		/	#8 & 9
Dry transfer man		/	#2
Foreman		/	#8 & 9
Grader		/	#8
Green lumber grader		/	#8
Green transfer man		/	#3
Kiln car puller		/	#8
Knife grinder		/	#9
Laborer		/	#2
Lister		/	#9
Lumber checker		/	#8 & 9
Lumber handler		/	#2
Lumber inspector		/	#8
Lumber piler		/	#2
Lumber sealer		/	#8 & 9
Milled lumber grader		/	#8 & 9
Nailer		/	#2
Off bearer		/	#2
Pick up man		/	#2
Rough lumber grader		/	#2
Sticker off bearer		/	#2
Yard foreman		/	#8

(Patternmaking)

Model maker	/		
Mock up man		/	#9
Layout man	/		
Estimator		/	#5
Patternmaking apprentice		/	#6
Shoe patternmaker		/	#6
Metal patternmaker		/	#6
Plaster patternmaker	/		
Plastic patternmaker	/		
Duplicator		/	#9
Pattern finisher	/		
Pattern rigger	/		
Gate man		/	#9
Wood patternmaker	/		
Pattern engineer		/	#2
Pattern checker		/	
Foreman (pattern)		/	#6 & 7
Metal pattern maker apprentice		/	#9

JOB NAME	SELECT		REASON
	Yes	No	
(Patternmaking)			
Die - layout man		/	#5
Pattern repair man		/	#9
Form builder		/	#9
Machine set up man		/	#9
Pattern girl		/	#2
(Mill Carpentry)			
Assembly man	/		
Bench man		/	
Cabinet frame assembler		/	
Hardware applicator	/		
Store furniture man		/	#7
Layout man	/		
Formica installer	/		
Furniture maker	/		
Cabinet and furniture repairer		/	
Millwright or millman		/	
Shaper operator		/	
Saw operator		/	#3
Foreman		/	#5 & 7
Lathe hand		/	#7
Wood turner	/		
Estimator		/	#5
Kitchen cabinet man	/		
Sprayer and finish man	/		
Bed maker		/	#3
Case framer		/	
Door maker		/	
Chair maker	/		
Frame maker	/		
Parts assembler		/	#2
Table maker		/	#3
Table assembler		/	#3
Furniture designer		/	#5
Cabinet designer		/	#5
Furniture reproducer		/	
Furniture inspector		/	
Furniture finisher		/	
Furniture apprentice		/	#7
Furniture packer or crater		/	
Paint and stain maker	/		
Mortiser operator		/	#2
Tennon operator		/	#2
Dovetailer		/	#2
Cut off saw operator		/	#2
Wood carver	/		
Cornice (plaster and plastics)		/	
Glazer		/	#2
Veneer man		/	#8

JOB NAME (Mill Carpentry)	SELECT		REASON
	Yes	No	
Wood former	/		
Toy maker		/	#8
Band-ripsaw operator		/	#2
Band-scroll saw operator		/	#2
Band-scroll saw helper		/	#2
Belt sander operator		/	#2
Belt sander horizontal operator		/	#2
Belt sander vertical operator		/	#2
Boring machine operator		/	#2
Horizontal boring machine operator		/	#2
Multiple boring machine operator		/	#2
Vertical boring machine operator		/	#2
Top bench hand		/	#9
Cabinet maker forman		/	#8
Cabinet maker maintenance		/	#9
Circular rip saw operator		/	#2
Cluster bore operator		/	#2
Cut off saw automatic operator		/	#2
Cut off saw operator		/	#2
Cut off saw helper		/	#2
Dado operator		/	#2
Double cut off saw operator		/	#2
Double spindle shaper operator		/	#2
Double surface operator		/	#2
Gangbore operator		/	#2
Glue clamp operator		/	#2
Glue man		/	#2
Jig saw operator		/	#2, 8 & 9
Jointer operator		/	#2, 8 & 9
Kiln operator		/	#8
Kiln operator apprentice		/	#8
Kiln stacker		/	#3
Lumberman's janitor		/	#3
Machine stacker		/	#2 & 3
Machine feeder		/	#2
Matcher operator		/	#2
Matcher off bearer		/	#2
Mill man apprentice		/	#2
Mill man helper		/	#2
Mitre sawer		/	#2
Molder feeder		/	#2
Molder off bearer		/	#2
Painting machine operator		/	#8 & 9
Molder operator		/	#2
Molder operator helper		/	#2
Molding grader		/	#2
Molding sander		/	#2
Mounter		/	#2
Nailer, grain doors		/	#2
Planer feeder		/	#2
Planer off bearer		/	#2

<u>JOB NAME</u> (Mill Carpentry)	<u>SELECT</u>		<u>REASON</u>
	<u>Yes</u>	<u>No</u>	
Planer operator	/		#2
Planer operator helper	/		#2
Power saw operator	/		#2
Re-run lumber grader	/		#2
Ripper	/		#2
Rip saw off bearer	/		#2
Rip saw operator	/		#2
Sampleman	/		#2
Sander	/		#2
Sanding machine off bearer	/		#2
Shaper operator	/		#2
Side-matcher-machine feeder	/		#2
Single-surface operator	/		#2
Square shaper operator	/		#2
Steam grader	/		#2 & 3
Stick man	/		#2
Sticker operator	/		#2
Straight run grader	/		#2
Swamper	/		#2 & 3
Swinging cut-off saw operator	/		#2
Tilt-head shaper operator	/		#2
Turning-sander operator	/		#2
Machine operator	/		#9
Variety saw operator	/		#9
Woodworking machine feeder	/		#2 & 3
Machine maintenance man	/		#9

APPENDIX B
GENERAL WOODWORKING
OCCUPATIONAL ANALYSES

A description of the characteristics and requirements of occupations for which preparation is offered by the public schools of Quincy, Massachusetts.

INTRODUCTION

The occupational analyses (ABLE/GUIDANCE/FORM G-1) provide both students and guidance counselors with quick-reference comprehensive guides to the jobs selected for a general woodworking job family vocational-technical curriculum and to some jobs usually associated with college degree educational plans.

Each analysis includes a brief description of the occupation and some of the tasks involved: listings of RELATED and LOWER LEVEL JOBS, where applicable, and PLACEMENT OPPORTUNITIES; indications of the expected EMPLOYMENT OUTLOOK, HOURS worked per week, and AVERAGE EARNINGS; information concerning the HIGH SCHOOL COURSE OF STUDY, EDUCATIONAL and TRAINING REQUIREMENTS, work conditions and PHYSICAL DEMANDS of the job; RELATION TO data, people, and things; personal INTERESTS, APTITUDES, and TEMPERAMENT compatible with the occupation. The analyses are arranged according to occupational areas.

Insofar as possible, the material reflects this information as it pertains to the Eastern Massachusetts metropolitan and similar areas. Local data and estimates were used in PLACEMENT OPPORTUNITIES, for example, in order to suggest potential nearby employment in the event that local opportunities change in the future.

Sources for the information contained in these occupational analyses are: the 1965 Dictionary of Occupational Titles, the 1966-67 Occupational Outlook Handbook, the 1964 Manpower Skills Survey, the Project ABLE coordinators, and various trade and professional associations, publications, and individual consultants in the community.

Various parts of the FORM G-1 are explained on the "SAMPLE: Occupational Analysis." It should be emphasized, however, that the labels used to indicate factors checked under CONDITIONS, PHYSICAL DEMANDS, INTERESTS, TEMPERAMENT, and RELATION TO are further explained in the appendix to the Dictionary of Occupational Titles, Volume II. For ease of reference, the content of these pages is reproduced and appended to these analyses.

SAMPLE

OCCUPATIONAL ANALYSIS

Brief description of job tasks.

Defined related titles as listed in D.O.T. (see Vol. II, p. vi).

Jobs with similar tasks at lower skill levels.

Employers who hire persons in this occupation.

Outlook for job openings in next 5-10 years in the Quincy and Greater Boston area.

Average regular work week for full-time job, with other time conditions noted as appropriate. (Hours for self-employed persons may vary considerably from the range indicated on this form.)

Regular earnings, excluding overtime and fringe benefits. (Income of self-employed persons may vary considerably from the range indicated on this form.)

On-the-job training required after high school other than short-term orientation in specific job or company procedures.

Formal apprenticeship program required after high school to reach journeyman status.

Requirements not otherwise indicated in other sections of this form.

Principal related tests indicated by D.O.T. Tests (DAT).

OCCUPATIONAL ANALYSIS																																		
VOC AREA	General Woodworking																																	
SUB FAMILY	Mill Carpentry																																	
<p>The ASSEMBLER working from a layout or blueprint, assembles furniture, fixtures, cabinets, etc., using clamps, squares, jigs, glue, etc.</p> <p>Assembling is a unit in the mill carpenter's apprenticeship training</p>																																		
<p>RELATED JOBS: subassembly man top-case assembler</p>																																		
<p>LOWER LEVEL JOBS: helper</p>																																		
<p>PLACEMENT OPPORTUNITIES: home and building construction furniture manufacturing custom and job shops</p>																																		
<p>EMPLOYMENT OUTLOOK: good</p>																																		
<p>HOURS: 40/week</p>																																		
<p>AVG. EARNINGS: \$1.50-3.00/hour</p>																																		
<p>HIGH SCHOOL COURSE OF STUDY:</p> <table border="1"> <tr><td>1 Business Education</td><td></td></tr> <tr><td>2 College Preparatory</td><td></td></tr> <tr><td>3 Computer Data Processing</td><td></td></tr> <tr><td>4 Electro Electronics</td><td></td></tr> <tr><td>5 Food Preparation</td><td></td></tr> <tr><td>6 General Piping</td><td></td></tr> <tr><td>7 General Woodworking</td><td>X</td></tr> <tr><td>8 Graphic & Commercial Art</td><td></td></tr> <tr><td>9 Health Occupations</td><td></td></tr> <tr><td>0 Home Economics</td><td></td></tr> <tr><td>X Metals & Machines</td><td></td></tr> <tr><td>Y Power Mechanics</td><td></td></tr> </table>		1 Business Education		2 College Preparatory		3 Computer Data Processing		4 Electro Electronics		5 Food Preparation		6 General Piping		7 General Woodworking	X	8 Graphic & Commercial Art		9 Health Occupations		0 Home Economics		X Metals & Machines		Y Power Mechanics										
1 Business Education																																		
2 College Preparatory																																		
3 Computer Data Processing																																		
4 Electro Electronics																																		
5 Food Preparation																																		
6 General Piping																																		
7 General Woodworking	X																																	
8 Graphic & Commercial Art																																		
9 Health Occupations																																		
0 Home Economics																																		
X Metals & Machines																																		
Y Power Mechanics																																		
<p>TOTAL EDUC/TRNG REQUIREMENTS:</p> <table border="1"> <tr><td>1 HS Grade Completed:</td><td>10</td><td>X</td></tr> <tr><td>2</td><td>11</td><td></td></tr> <tr><td>3</td><td>12</td><td></td></tr> <tr><td>4</td><td>13 & '4</td><td></td></tr> <tr><td>5 On-The-Job Training</td><td>1 year</td><td></td></tr> <tr><td>6 Apprentice Training</td><td></td><td></td></tr> <tr><td>7 Post-HS Tech/Trade</td><td></td><td></td></tr> <tr><td>8 Business College</td><td></td><td></td></tr> <tr><td>9 Jr College (2 yr)</td><td></td><td></td></tr> <tr><td>0 College Graduate</td><td></td><td></td></tr> <tr><td>X Graduate School</td><td></td><td></td></tr> </table>		1 HS Grade Completed:	10	X	2	11		3	12		4	13 & '4		5 On-The-Job Training	1 year		6 Apprentice Training			7 Post-HS Tech/Trade			8 Business College			9 Jr College (2 yr)			0 College Graduate			X Graduate School		
1 HS Grade Completed:	10	X																																
2	11																																	
3	12																																	
4	13 & '4																																	
5 On-The-Job Training	1 year																																	
6 Apprentice Training																																		
7 Post-HS Tech/Trade																																		
8 Business College																																		
9 Jr College (2 yr)																																		
0 College Graduate																																		
X Graduate School																																		
<p>SPECIAL REQUIREMENTS:</p> <p>Minimum age: 16</p>																																		

ABLE/GUIDANCE/FORM G-1

Job title as generally used in the local area.

Job title used in D.O.T. if differing from local usage.

Code number according to 1965 Dictionary of Occupational Titles (D.O.T.) classification system. (If a specific job is not defined in the D.O.T., the number for a similar job is used as the basis for this analysis.)

OCCUPATIONAL ANALYSIS

FAMILY Mill Carpentry **JOB** Assembler **D.O.T.** 763.884
(D.O.T.: Furniture Assembler)

SCHOOL COURSE OF STUDY:	
Business Education	
College Preparatory	
Computer Data Processing	
Electro Electronics	
Food Preparation	
General Piping	
General Woodworking	X
Graphic & Commercial Art	
Health Occupations	
Home Economics	
Metals & Machines	
Power Mechanics	

CONDITIONS:	
1 Inside	X
2 Outside	
3 Both	
4 Cold temp	
5 Hot temp	
6 Wet, humid	
7 Noise, vibration	
8 Hazards *	X
9 Fumes	
10 Odors	
11 Toxic	
12 Dust	
13 Poor ventilation	
14 Other	X
Work area some times messy	
* Falling objects	

APTITUDES:	
1 Verbal	
2 Numerical	
3 Abstract	
4 Spatial	
5 Clerical	
6 Mechanical	X
7 Spelling	
8 Grammar	

PHYSICAL DEMANDS:	
1 Strength	L-M
2 Climbing, balancing	
3 Stooping, kneeling, crawling	X
4 Manual dexterity	X
5 Talking, hearing	
6 Visual acuity	X
7 Other	
Standing for long time periods	

INTERESTS:	
1 Dealing with things & objects	X
2 Business contact with people	
3 Routine, system	X
4 Social welfare	
5 Prestige, esteem	
6 Communication of ideas	
7 Science & technology	
8 Abstraction, creativity	
9 Machines, procedures	X
10 Tangible results	X

TEMPERAMENT:	
1 Varied duties, frequent change	
2 Repeated, set procedures	X
3 Matching specified instructions	
4 Directing & planning for others	
5 Working with others	
6 Working alone & apart	
7 Influencing other people's ideas	
8 Risks, unexpected events, emergencies	
9 Making empirical judgments, decisions	
10 Analyzing facts and figures	
11 Interpreting personal feelings	
12 Precision, accuracy	X

RELATION TO:	
1 Data:	
2 People:	
3 Things: Manipulating	X

SPECIAL EDUC/TRNG REQUIREMENTS:	
Grade Completed:	10 X
	11
	12
	13 & 14
On-The-Job Training	1 year
Apprentice Training	
Post-HS Tech/Trade	
Business College	
4 yr College (2 yr)	
College Graduate	
Graduate School	

SPECIAL REQUIREMENTS:	
Minimum age:	16

ABLE/GUIDANCE/FORM G-1

For detailed explanations and definitions of

INTERESTS
CONDITIONS
TEMPERAMENT
PHYSICAL DEMANDS
RELATION TO Data, People, Things

refer to the attached appendix.

Strength requirements:

S Sedentary
L Light
M Medium
H Heavy
VH Very Heavy

PRIMARY SOURCES OF OCCUPATIONAL ANALYSIS DATA

Project ABLE coordinators
U. S. Department of Labor. Dictionary of occupational titles. Washington: U. S. Government Printing Office, 1965.

Principal related aptitudes as indicated by Differential Aptitude Tests (DAT).



Additional Specific Notes

HOURS: Though the workweek in many cases is currently 40 hours, a trend to a shorter week is already evident.

AVG. EARNINGS: The figures given show the range of income that most people in a vocation are apt to make; a few individuals may make less or considerably more. A person in a supervisory position, for example, may make much more than others who have essentially the same occupation. Earnings figures would also vary due to other factors: part-time workers are sometimes paid less per hour than full-time personnel; persons who work at night, on holidays, or weekends, etc., may receive extra compensation; the wage scale for a given occupation may differ according to location and other specific employment conditions.

SPECIAL REQUIREMENTS: Attention is called to a minimum age requirement only when it is required by law, employers, or local practice for a specific job or task; child-labor-law and other requirements that apply generally to all employees are not specified.

Some Terms Defined

BENCH HAND: a person who works at a worktable, using his hands or hand tools.

JOURNEYMAN: a worker who has trained to a high skill level in a craft; an artisan; usually has completed apprenticeship training or extended on-the-job training; usually must have passed an examination and may be required to have a license.

MECHANIC: a skilled worker; in some trades, synonymous with JOURNEYMAN.

APPRENTICESHIP TRAINING: a period of journeyman-supervised, on-the-job training and classroom instruction which has been formalized by agreement between a union or other employee group and representatives of employers or employer groups in order to produce all-round proficiency in a craft. The agreement usually specifies: the number of trainees; apprentice qualifications such as minimum and maximum age limits, education (usually high school degree or its equivalent), aptitude, and physical prerequisites; length and arrangement of the total training period and of major segments of training; rate of pay at successive intervals; policies concerning whether advanced standing is given for vocational-technical school training, military or job experience in the trade. The apprentice signs a contract with the joint apprenticeship committee supervising the program, or with his employer if no registered apprenticeship program is set up in his location or specific trade; he agrees to complete the program and in some cases to work for the employer furnishing the training for a specified period of time after completion.

INTERNSHIP: a period of closely supervised on-the-job training providing practical experience for graduates of some professional curricula.

ON-THE-JOB TRAINING: informal training acquired in the course of actually working with the materials and tools of the occupation, usually starting with simple tasks performed under close supervision and progressing to more difficult work and more independence of action.

HAND TOOL: a tool held and guided by the hands alone; e.g., hammer, chisel, file, wrench, screwdriver, handsaw, brace, vise, plane.

POWER TOOL: a portable electric- or pneumatic-powered tool; e.g., portable electric handsaw, portable electric drill, portable grinder, pneumatic impact wrench.

MACHINE TOOL: a power driven machine that shapes or cuts metal, wood, and/or other materials; it holds both the work and the cutting tool, driving one or the other, and feeding either the cutting tool into the work or the work into the cutting tool; e.g., jointer, vertical drill, band saw, turret lathe, vertical milling machine, box and pan brake.

PRECISION MEASURING INSTRUMENT: a device which indicates extremely accurate measurements, even in some cases to millionths of an inch; e.g., micrometer caliper, micrometer depth gage, electronic height gage, sine bar, jo block.

CAPTIVE SHOP: a shop or department in or controlled by a company or organization to provide services or materials for the company's own use and not necessarily related to its market functions; e.g., a large insurance company might have a captive printing shop (department) to publish forms used in its business operations.

JOB SHOP: a shop that does odd-lot, occasional, and/or variable pieces of work, usually in limited quantities; opposed to a production shop that makes large numbers of identical or similar items; e.g., a machine job shop might make to order six pumps for a water system whereas a machine production shop would manufacture thousands of identical automotive water pumps.

CUSTOM SHOP: a shop or business that does work, usually one-of-a-kind, on individual order; e.g., a carpentry custom shop may specialize in custom installations of kitchen cabinets and other built-ins, remodeling work, etc.

GENERAL WOODWORKING

CARPENTRY

cribber	GW-1
scaffold carpenter	GW-2
flask carpenter	GW-3
painter	GW-4
roofer	GW-5
framer	GW-6
tile man	GW-7
wallboard carpenter	GW-8
cabinet installer	GW-9
siding applicator	GW-10
finishman	GW-11
millman	GW-12
boatbuilder	GW-13
construction technician	GW-14

MILL CARPENTRY

assembler	GW-15
hardware applicator	GW-16
wood turner	GW-17
plastic-top installer	GW-18
paint and stain mixer	GW-19
sprayer and finish man	GW-20
furniture maker	GW-21
kitchen cabinet maker	GW-22
layout man (mill carpentry)	GW-23
interior designer	GW-24

PATTERNMAKING

molder (pattern)	GW-25
pattern finisher	GW-26
pattern rigger	GW-27
metal patternmaker	GW-28
plaster patternmaker	GW-29
plastics patternmaker	GW-30
model maker	GW-31
layout man (pattern)	GW-32
general patternmaker	GW-33
pattern technician	GW-34

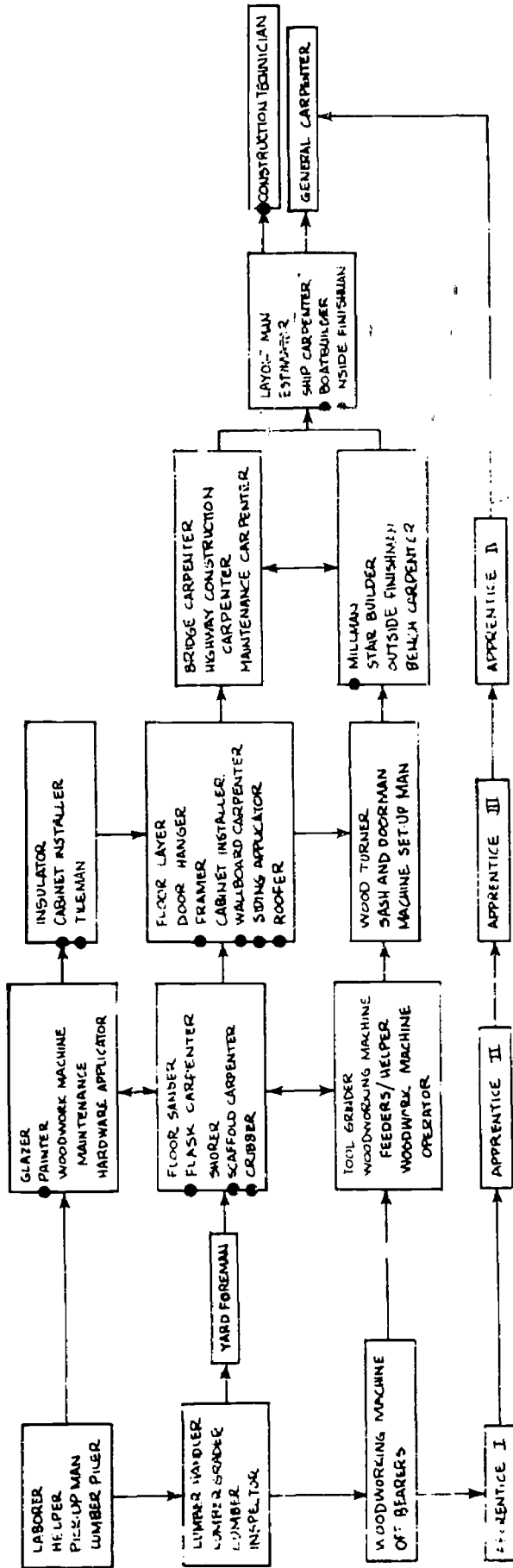

GENERAL WOODWORKING
CARPENTRY

GENERAL WOODWORKING: CARPENTRY

Carpenters make up the largest group of craftsmen in the building trades. Great skill is required to work with the materials, tools, and methods developed for use in construction today.

Construction work includes not only residential, commercial, industrial, and public buildings but also roads, bridges, dams, tunnels, and similar structures, as well as ships and other transportation equipment. In urban areas, carpenters tend to specialize in a particular field of construction and sometimes in the particular type of work performed. Thus a carpenter working for a homebuilding firm, for example, may install only hardwood floors or acoustic panels or millwork, and so on.

Although the general (journeyman) carpenter is not specified as a job in this curriculum, some of the skills he must develop are represented in the specialized carpentry jobs selected. That is, apprenticeship training for carpentry would include cribbing, roofing, framing, tile setting, siding, finishing, and other types of work. Vocational-technical training in these skills would be credited against apprenticeship time, or a carpenter may qualify to work in this field by augmenting vocational-technical training with on-the-job training.

The outlook for employment for carpenters is directly related to the economic outlook for the construction industry in general. In addition, a new development in this field is businesses specializing in repair and remodeling of homes and other buildings. Many carpenters do maintenance work in factories, office buildings, and other large establishments or work in captive shops in non-construction firms or governmental agencies. Some are self-employed or supplement other employment by doing small jobs on their own time.

OCCUPATIONAL ANALYSIS

VOC AREA General Woodworking SUB FAMILY Carpentry JOB Cribber (D.O.T.: Shorer) D.O.T. 860.884

The CRIBBER
sets up timbers, cross braces, and sheathing to form a temporary retaining wall to hold concrete until it sets. He uses both hand and power tools. A man trained only in cribbing would work for a large construction company or a company specializing in cribbing or form work; cribbing is also a unit in apprenticeship training for carpenter.

LOWER LEVEL JOBS:
apprentice, helper, laborer

PLACEMENT OPPORTUNITIES:
home and building construction foundries
aircraft, missile, and space-craft manufacturing
railroad, bridge, and highway construction; boatbuilding
maintenance, repair, remodeling

EMPLOYMENT OUTLOOK: increasing
HOURS: 40/week
AVG. EARNINGS: \$1.75-4.50/hour

HIGH SCHOOL COURSE OF STUDY:

1	Business Education	
2	College Preparatory	
3	Computer Data Processing	
4	Electro Electronics	
5	Food Preparation	
6	General Piping	
7	General Woodworking	X
8	Graphic & Commercial Art	
9	Health Occupations	
0	Home Economics	
X	Metals & Machines	
Y	Power Mechanics	

TOTAL EDUC/TRNG REQUIREMENTS:

1	HS Grade Completed:	10	X
2		11	
3		12	
4		13 & 14	
5	On-The-Job Training	1 year	
6	Apprentice Training		
7	Post-HS Tech/Trade		
8	Business College		
9	Jr College (2 yr)		
0	College Graduate		
X	Graduate School		

SPECIAL REQUIREMENTS:

Minimum age:	16
Knowledge of building codes	

CONDITIONS:

1	Inside	
	Outside	X
	Both	
2	Cold temp	
3	Hot temp	
4	Vet, humid	
5	Noise, vibration	
6	Hazards*	X
7	Fumes	
	Odors	
	Toxic	
	Dust	X
	Poor ventilation	
8	Other	X
	Exposure to dirt	
	Working at heights	

*Power tools; flying chips

APTITUDES:

1	Verbal	
2	Numerical	
3	Abstract	
4	Spatial	X
5	Clerical	X
6	Mechanical	X
7	Spelling	
8	Grammar	

PHYSICAL DEMANDS:

1	Strength	M
2	Climbing, balancing	H
3	Stooping, kneeling, crawling	X
4	Manual dexterity	X
5	Talking, hearing	
6	Visual acuity	X
7	Other	X
	Standing for long time periods	

INTERESTS:

1	Dealing with things & objects	X
2	Business contact with people	
3	Routine, system	X
4	Social welfare	
5	Prestige, esteem	
6	Communication of ideas	
7	Science & technology	
8	Abstraction, creativity	
9	Machines, procedures	X
0	Tangible results	X

TEMPERAMENT:

1	Varied duties, frequent change	
2	Repeated, set procedures	X
3	Matching specified instructions	
4	Directing & planning for others	
5	Working with others	
6	Working alone & apart	
7	Influencing other people's ideas	
8	Risks, unexpected events, emergencies	
9	Making empirical judgments, decisions	
0	Analyzing facts and figures	
X	Interpreting personal feelings	
Y	Precision, accuracy	X

RELATION TO:

1	Data:	
2	People:	
3	Things: Manipulating	X

AREA General Woodworking

SUB FAMILY Carpentry

JOB Scaffold Carpenter

O.O.T. 860,781

(D.O.T.: Rough Carpenter)

The SCAFFOLD CARPENTER

erects, moves, and removes wooden staging and scaffolding on and around construction jobs and ship structures to afford access to sites of work. He installs ladders, handrails, walkways, platforms, and gangways and provides rigging to support machines. He is responsible for insuring the safety of those who will be working at the site. Carpenters specializing in scaffold building are usually employed by large construction firms; in small firms this work is part of the general carpenter's job.

LOWER LEVEL JOBS:

helper, apprentice, laborer

PLACEMENT OPPORTUNITIES:

home and building construction
missile, spacecraft, and aircraft industry
bridge and highway construction
foundries
shipbuilding

EMPLOYMENT OUTLOOK: increasing

HOURS: 40/week

AVG. EARNINGS: \$1.75-4.50/hour

HIGH SCHOOL COURSE OF STUDY:

1	Business Education
2	College Preparatory
3	Computer Data Processing
4	Electro Electronics
5	Food Preparation
6	General Piping
7	General Woodworking <input checked="" type="checkbox"/>
8	Graphic & Commercial Art
9	Health Occupations
10	Home Economics
X	Metals & Machines
Y	Power Mechanics

TOTAL EDUC/TRNG REQUIREMENTS:

1	HS Grade Completed:	10	<input checked="" type="checkbox"/>
2		11	
3		12	
4		13 & 14	
5	On-The-Job Training	1 year	
6	Apprentice Training		
7	Post-HS Tech/Trade		
8	Business College		
9	Jr College (2 yr)		
10	College Graduate		
X	Graduate School		

SPECIAL REQUIREMENTS:

Minimum age: 16
Knowledge of building codes

CONDITIONS:

1	Inside
	Outside
	Both <input checked="" type="checkbox"/>
2	Cold temp
3	Hot temp
4	Wet, humid
5	Noise, vibration
6	Hazards * <input checked="" type="checkbox"/>
7	Fumes
	Odors
	Toxic
	Dust
	Poor ventilation
8	Other <input checked="" type="checkbox"/>
	Exposure to dirt
	Working at heights

*Power tools; flying chips

APTITUDES:

1	Verbal
2	Numerical
3	Abstract
4	Spatial <input checked="" type="checkbox"/>
5	Clerical <input checked="" type="checkbox"/>
6	Mechanical <input checked="" type="checkbox"/>
7	Spelling
8	Grammar

PHYSICAL DEMANDS:

1	Strength	M/R
2	Climbing, balancing	<input checked="" type="checkbox"/>
3	Stooping, kneeling, crawling	<input checked="" type="checkbox"/>
4	Manual dexterity	<input checked="" type="checkbox"/>
5	Talking, hearing	
6	Visual acuity	<input checked="" type="checkbox"/>
7	Other	
	Standing for long time periods	<input checked="" type="checkbox"/>

INTERESTS:

1	Dealing with things & objects	<input checked="" type="checkbox"/>
2	Business contact with people	
3	Routine, system	
4	Social welfare	
5	Prestige, esteem	
6	Communication of ideas	
7	Science & technology	
8	Abstraction, creativity	
9	Machines, procedures	<input checked="" type="checkbox"/>
10	Tangible results	<input checked="" type="checkbox"/>

TEMPERAMENT:

1	Varied duties, frequent change	<input checked="" type="checkbox"/>
2	Repeated, set procedures	
3	Matching specified instructions	
4	Directing & planning for others	
5	Working with others	
6	Working alone & apart	
7	Influencing other people's ideas	
8	Risks, unexpected events, emergencies	
9	Making empirical judgments, decisions	<input checked="" type="checkbox"/>
10	Analyzing facts and figures	<input checked="" type="checkbox"/>
X	Interpreting personal feelings	
Y	Precision, accuracy	<input checked="" type="checkbox"/>

RELATION TO:

1	Data:
2	People:
3	Things: Precision Working <input checked="" type="checkbox"/>

The FLASK CARPENTER

makes and repairs flasks used in foundries where large castings are manufactured. (A flask is a frame which holds a pattern around which sand is rammed to make a mold.) He operates woodworking machines, power and hand tools.

LOWER LEVEL JOBS: helper

PLACEMENT OPPORTUNITIES:

ferrous and nonferrous foundries

EMPLOYMENT OUTLOOK:
slight increase

HOURS: 40/week

AVG. EARNINGS: \$1.50-3.50/hour

HIGH SCHOOL COURSE OF STUDY:

1 Business Education	
2 College Preparatory	
3 Computer Data Processing	
4 Electro Electronics	
5 Food Preparation	
6 General Piping	
7 General Woodworking	X
8 Graphic & Commercial Art	
9 Health Occupations	
0 Home Economics	
X Metals & Machines	
Y Power Mechanics	

TOTAL EDUC/TRNG REQUIREMENTS:

1 HS Grade Completed:	10 X
2	11
3	12
4	13 & 14
5 On-The-Job Training	1-1 year
6 Apprentice Training	
7 Post-HS Tech/Trade	
8 Business College	
9 Jr College (2 yr)	
0 College Graduate	
X Graduate School	

SPECIAL REQUIREMENTS:

Minimum age: 18

CONDITIONS:

1 Inside	X
Outside	
Both	
2 Cold temp	
3 Hot temp	
4 Wet, humid	
5 Noise, vibration	
6 Hazards *	X
7 Fumes	X
Odors	X
Toxic	X
Dust	X
Poor ventilation	
8 Other	X
Exposure to dirt	

*Power tools; flying chips

APTITUDES:

1 Verbal	
2 Numerical	X
3 Abstract	
4 Spatial	X
5 Clerical	X
6 Mechanical	X
7 Spelling	
8 Grammar	

PHYSICAL DEMANDS:

1 Strength	M-H
2 Climbing, balancing	
3 Stooping, kneeling, crawling	X
4 Manual dexterity	X
5 Talking, hearing	
6 Visual acuity	X
7 Other	X
Standing for long time periods	

INTERESTS:

1 Dealing with things & objects	X
2 Business contact with people	
3 Routine, system	
4 Social welfare	
5 Prestige, esteem	
6 Communication of ideas	
7 Science & technology	
8 Abstraction, creativity	
9 Machines, procedures	X
0 Tangible results	X

TEMPERAMENT:

1 Varied duties, frequent change	
2 Repeated, set procedures	
3 Matching specified instructions	
4 Directing & planning for others	
5 Working with others	
6 Working alone & apart	
7 Influencing other people's ideas	
8 Risks, unexpected events, emergencies	
9 Making empirical judgments, decisions	
0 Analyzing facts and figures	X
X Interpreting personal feelings	
Y Precision, accuracy	X

RELATION TO:

1 Data: Compiling	X
2 People:	
3 Things: Precision Working	X

In carpentry the PAINTER applies priming paint to pieces which will not be accessible when assembled or which will be exposed to weather before they can be painted (backs of gutters, window casings, exterior finish, doors, etc.). When necessary he sands, fills, and otherwise prepares the wood before priming it.

LOWER LEVEL JOBS:
helper, apprentice

PLACEMENT OPPORTUNITIES:
all wood industries

EMPLOYMENT OUTLOOK:
slight increase

HOURS: 40/week

AVG. EARNINGS: \$1.50-3.00/hour

HIGH SCHOOL COURSE OF STUDY:

1 Business Education	
2 College Preparatory	
3 Computer Data Processing	
4 Electro Electronics	
5 Food Preparation	
6 General Piping	
7 General Woodworking	X
8 Graphic & Commercial Art	
9 Health Occupations	
10 Home Economics	
X Metals & Machines	
Y Power Mechanics	

TOTAL EDUC/TRNG REQUIREMENTS:

1 HS Grade Completed:	10	X
2	11	
3	12	
4	13 & 14	
5 On-The-Job Training		
6 Apprentice Training		
7 Post-HS Tech/Trade		
8 Business College		
9 Jr College (2 yr)		
10 College Graduate		
X Graduate School		

SPECIAL REQUIREMENTS:

Minimum age: 16

CONDITIONS:

1 Inside	
Outside	
Both	X
2 Cold temp	
3 Hot temp	
4 Wet, humid	
5 Noise, vibration	
6 Hazards	
7 Fumes	
Odors	X
Toxic	X
Dust	
Poor ventilation	
8 Other	X
Working at heights	

APTITUDES:

1 Verbal	
2 Numerical	
3 Abstract	
4 Spatial	X
5 Clerical	X
6 Mechanical	X
7 Spelling	
8 Grammar	

PHYSICAL DEMANDS:

1 Strength	L,M
2 Climbing, balancing	X
3 Stooping, kneeling, crawling	X
4 Manual dexterity	X
5 Talking, hearing	
6 Visual acuity	X
7 Other	X
Standing for long time periods	

INTERESTS:

1 Dealing with things & objects	X
2 Business contact with people	
3 Routine, system	
4 Social welfare	
5 Prestige, esteem	
6 Communication of ideas	
7 Science & technology	
8 Abstraction, creativity	
9 Machines, procedures	X
10 Tangible results	X

TEMPERAMENT:

1 Varied duties, frequent change	X
2 Repeated, set procedures	
3 Matching specified instructions	
4 Directing & planning for others	
5 Working with others	
6 Working alone & apart	
7 Influencing other people's ideas	
8 Risks, unexpected events, emergencies	
9 Making empirical judgments, decisions	X
10 Analyzing facts and figures	X
X Interpreting personal feelings	
Y Precision, accuracy	X

RELATION TO:

1 Data:	
2 People:	
3 Things: Precision Working	X

The ROOFER

computes the amount of roofing materials needed to surface or repair a roof; cuts materials, if necessary, to fit edges, corners, around pipes, etc.; applies and fastens materials to roofing base. He may be employed by a roofing contractor or by a general construction company.

Roofing is also part of the carpenter's apprenticeship training.

LOWER LEVEL JOBS:

helper, apprentice

PLACEMENT OPPORTUNITIES:

construction and repair of homes and other buildings

EMPLOYMENT OUTLOOK: increasing

HOURS: 40/week

AVG. EARNINGS: \$1.50-5.00/hour

HIGH SCHOOL COURSE OF STUDY:

1 Business Education	
2 College Preparatory	
3 Computer Data Processing	
4 Electro Electronics	
5 Food Preparation	
6 General Pipng	
7 General Woodworking	X
8 Graphic & Commercial Art	
9 Health Occupations	
0 Home Economics	
X Metals & Machines	
Y Power Mechanics	

TOTAL EDUC/TRNG REQUIREMENTS:

1 HS Grade Completed:	10
2	11 X
3	12
4	13 & 14
5 On-The-Job Training	6 months
6 Apprentice Training	
7 Post-HS Tech/Trade	
8 Business College	
9 Jr College (2 yr)	
0 College Graduate	
X Graduate School	

SPECIAL REQUIREMENTS:

Minimum age:	16
--------------	----

CONDITIONS:

1 Inside	
Outside	X
Both	
2 Cold temp	
3 Hot temp	
4 Wet, humid	
5 Noise, vibration	
6 Hazards *	X
7 Fumes	X
Odors	
Toxic	
Dust	X
Poor ventilation	
8 Other	X
Exposure to dirt Working at heights	
Flying pebbles & grit	

*APTITUDES:

1 Verbal	
2 Numerical	X
3 Abstract	
4 Spatial	X
5 Clerical	X
6 Mechanical	X
7 Spelling	
8 Grammar	

PHYSICAL DEMANDS:

1 Strength	M, H
2 Climbing, balancing	X
3 Stooping, kneeling, crawling	X
4 Manual dexterity	X
5 Talking, hearing	
6 Visual acuity	X
7 Other	

INTERESTS:

1 Dealing with things & objects	X
2 Business contact with people	
3 Routine, system	
4 Social welfare	
5 Prestige, esteem	
6 Communication of ideas	
7 Science & technology	
8 Abstraction, creativity	
9 Machines, procedures	X
0 Tangible results	X

TEMPERAMENT:

1 Varied duties, frequent change	
2 Repeated, set procedures	
3 Matching specified instructions	
4 Directing & planning for others	
5 Working with others	
6 Working alone & apart	
7 Influencing other people's ideas	
8 Risks, unexpected events, emergencies	
9 Making empirical judgments, decisions	
0 Analyzing facts and figures	X
X Interpreting personal feelings	
Y Precision, accuracy	X

RELATION TO:

1 Data:Compiling	X
2 People:	
3 Things:Precision Working	X

(D.O.T.: Carpenter, Framing)

HIGH SCHOOL COURSE OF STUDY:

1 Business Education	
2 College Preparatory	X
3 Computer Data Processing	
4 Electro Electronics	
5 Food Preparation	
6 General Piping	
7 General Woodworking	X
8 Graphic & Commercial Art	
9 Health Occupations	
0 Home Economics	
X Metals & Machines	
Y Power Mechanics	

The FRAMER erects outside, inside, and roof framing according to blueprint and layout specifications. He also applies sheathing to the framing and he may do some finish or trim work. Using hand and power tools, he may specialize in framing work for a general construction company or he may be employed by a framing contractor. Framing is also a unit in the carpenter's apprenticeship training.

LOWER LEVEL JOBS:

helper, apprentice, laborer

PLACEMENT OPPORTUNITIES:

home and building construction
missile, spacecraft, and aircraft
manufacturing
boatbuilding

EMPLOYMENT OUTLOOK: increasing

HOURS: 40/week

AVG. EARNINGS: \$ 1.75-5.00/hour

CONDITIONS:

1 Inside	
Outside	X
Both	
2 Cold temp	
3 Hot temp	
4 Wet, humid	
5 Noise, vibration	
6 Hazards *	X
7 Fumes	
Odors	
Toxic	
Dust	X
Poor ventilation	
3 Other	X

Working at heights

*Power tools; flying chips

APTITUDES:

1 Verbal	
2 Numerical	X
3 Abstract	
4 Spatial	X
5 Clerical	X
6 Mechanical	X
7 Spelling	
8 Grammar	

PHYSICAL DEMANDS:

1 Strength	MH
2 Climbing, balancing	X
3 Stooping, kneeling, crawling	X
4 Manual dexterity	X
5 Talking, hearing	
6 Visual acuity	X
7 Other	X

Standing for long periods of time

INTERESTS:

1 Dealing with things & objects	X
2 Business contact with people	
3 Routine, system	
4 Social welfare	
5 Prestige, esteem	
6 Communication of ideas	
7 Science & technology	
8 Abstraction, creativity	
9 Machines, procedures	X
0 Tangible results	X

TEMPERAMENT:

1 Varied duties, frequent change	
2 Repeated, set procedures	
3 Matching specified instructions	
4 Directing & planning for others	
5 Working with others	
6 Working alone & apart	
7 Influencing other people's ideas	
8 Risks, unexpected events, emergencies	
9 Making empirical judgments, decisions	
0 Analyzing facts and figures	X
X Interpreting personal feelings	
Y Precision, accuracy	X

RELATION TO:

1 Data: Compiling	X
2 People:	
3 Things: Precision Working	X

The TILE MAN

applies soft-tile coverings (such as composition tile) to walls, floors, and sometimes ceilings according to specifications or designs. He shapes the tile when necessary by heating it and cutting it with a knife, shears, or power tool.

The journeyman carpenter's apprenticeship training would include some tile work.

LOWER LEVEL JOBS:

helper, apprentice

PLACEMENT OPPORTUNITIES:

home and building construction maintenance, repair, remodeling work floor-covering companies self-employment

EMPLOYMENT OUTLOOK: increasing

HOURS: 40/week

AVG. EARNINGS: \$1.75-5.00/hour

HIGH SCHOOL COURSE OF STUDY:

1 Business Education	
2 College Preparatory	
3 Computer Data Processing	
4 Electro Electronics	
5 Food Preparation	
6 General Piping	
7 General Woodworking	X
8 Graphic & Commercial Art	
9 Health Occupations	
0 Home Economics	
X Metals & Machines	
Y Power Mechanics	

TOTAL EDUC/TRNG REQUIREMENTS:

1 HS Grade Completed:	10
2	11 X
3	12
4	13 & 14
5 On-The-Job Training	6 mo.
6 Apprentice Training	
7 Post-HS Tech/Trade	
8 Business College	
9 Jr College (2 yr)	
0 College Graduate	
X Graduate School	

SPECIAL REQUIREMENTS:

Minimum age: 16
Knowledge of building codes

CONDITIONS:

1 Inside	X
Outside	
Both	
2 Cold temp	
3 Hot temp	
4 Wet, humid	
5 Noise, vibration	X
6 Hazards *	X
7 Fumes	X
Odors	
Toxic	X
Dust	
Poor ventilation	
8 Other	

*Power tools; flying chips

APTITUDES:

1 Verbal	
2 Numerical	
3 Abstract	
4 Spatial	X
5 Clerical	X
6 Mechanical	X
7 Spelling	
8 Grammar	

PHYSICAL DEMANDS:

1 Strength	M
2 Climbing, balancing	
3 Stooping, kneeling, crawling	X
4 Manual dexterity	X
5 Talking, hearing	
6 Visual acuity	X
7 Other	

INTERESTS:

1 Dealing with things & objects	X
2 Business contact with people	
3 Routine, system	
4 Social welfare	
5 Prestige, esteem	
6 Communication of ideas	
7 Science & technology	
8 Abstraction, creativity	
9 Machines, procedures	X
0 Tangible results	X

TEMPERAMENT:

1 Varied duties, frequent change	X
2 Repeated, set procedures	
3 Matching specified instructions	
4 Directing & planning for others	
5 Working with others	
6 Working alone & apart	
7 Influencing other people's ideas	
8 Risks, unexpected events, emergencies	
9 Making empirical judgments, decisions	X
0 Analyzing facts and figures	X
X Interpreting personal feelings	
Y Precision, accuracy	X

RELATION TO:

1 Data:	
2 People:	
3 Things: Precision Working	X

The WALLBOARD CARPENTER

cuts, fits, and applies paneling, wallboard, and ceilings in buildings and dwellings. He uses woodworking machines, such as portable circular saws, planers, or jointers, as well as various hand tools.

Apprenticeship training for the general carpenter would include wallboard work.

RELATED JOBS:

acoustical carpenter
building-insulating carpenter

LOWER LEVEL JOBS:

helper, apprentice

PLACEMENT OPPORTUNITIES:

home and building construction
repair and alteration work
bridge and highway construction
defense and spacecraft industries

EMPLOYMENT OUTLOOK: good

HOURS: 40/week

AVG. EARNINGS: \$1.75-5.00/hour

HIGH SCHOOL COURSE OF STUDY:	
1 Business Education	
2 College Preparatory	
3 Computer Data Processing	
4 Electro Electronics	
5 Food Preparation	
6 General Piping	
7 General Woodworking	X
8 Graphic & Commercial Art	
9 Health Occupations	
0 Home Economics	
X Metals & Machines	
Y Power Mechanics	

TOTAL EDUC/TRNG REQUIREMENTS:	
1 HS Grade Completed:	10
2	11 X
3	12
4	13 & 14
5 On-The-Job Training	1 year
6 Apprentice Training	
7 Post-HS Tech/Trade	
8 Business College	
9 Jr College (2 yr)	
0 College Graduate	
X Graduate School	

SPECIAL REQUIREMENTS:	
Minimum age:	16
Knowledge of building codes	

CONDITIONS:	
1 Inside	X
Outside	
Both	
2 Cold temp	
3 Hot temp	
4 Wet, humid	
5 Noise, vibration	
6 Hazards*	X
7 Fumes	
Odors	
Toxic	
Dust	X
Poor ventilation	X
8 Other	X
Exposure to dirt	
Working at heights	

*Power tools; flying chips

APTITUDES:	
1 Verbal	
2 Numerical	X
3 Abstract	
4 Spatial	X
5 Clerical	X
6 Mechanical	X
7 Spelling	
8 Grammar	

PHYSICAL DEMANDS:	
1 Strength	M/H
2 Climbing, balancing	X
3 Stooping, kneeling, crawling	X
4 Manual dexterity	X
5 Talking, hearing	
6 Visual acuity	X
7 Other	
Standing for long time periods	X

INTERESTS:	
1 Dealing with things & objects	X
2 Business contact with people	
3 Routine, system	
4 Social welfare	
5 Prestige, esteem	
6 Communication of ideas	
7 Science & technology	
8 Abstraction, creativity	
9 Machines, procedures	X
0 Tangible results	X

TEMPERAMENT:	
1 Varied duties, frequent change	
2 Repeated, set procedures	
3 Matching specified instructions	
4 Directing & planning for others	
5 Working with others	
6 Working alone & apart	
7 Influencing other people's ideas	
8 Risks, unexpected events, emergencies	
9 Making empirical judgments, decisions	
0 Analyzing facts and figures	X
X Interpreting personal feelings	
Y Precision, accuracy	X

RELATION TO:	
1 Data: Compiling	X
2 People:	
3 Things: Precision Working	X

The CABINET INSTALLER

using hand and/or power tools, cuts and fits prefabricated cabinets and counters to specified positions. He also cuts, applies, and fastens soffits and moldings to the cabinets and counters.

A journeyman carpenter would also have training in cabinet installation as part of his apprenticeship.

LOWER LEVEL JOBS:

helper, apprentice

PLACEMENT OPPORTUNITIES:

home and building construction repair and alteration work retail outlets and jobbers selling prefabricated cabinets

EMPLOYMENT OUTLOOK: good

HOURS: 40/week

AVG. EARNINGS: \$1.50-5.00/hour

HIGH SCHOOL COURSE OF STUDY:	
1 Business Education	
2 College Preparatory	
3 Computer Data Processing	
4 Electro Electronics	
5 Food Preparation	
6 General Piping	
7 General Woodworking	X
8 Graphic & Commercial Art	
9 Health Occupations	
0 Home Economics	
X Metals & Machines	
Y Power Mechanics	

TOTAL EDUC/TRNG REQUIREMENTS:	
1 HS Grade Completed:	10
2	11 X
3	12
4	13 & 14
5 On-The-Job Training	1 year
6 Apprentice Training	
7 Post-HS Tech/Trade	
8 Business College	
9 Jr College (2 yr)	
0 College Graduate	
X Graduate School	

SPECIAL REQUIREMENTS:	
Minimum age:	16
Knowledge of building codes	

CONDITIONS:	
1 Inside	X
Outside	
Both	
2 Cold temp	
3 Hot temp	
4 Wet, humid	
5 Noise, vibration	X
6 Hazards *	
7 Fumes	
Odors	
Toxic	
Dust	X
Poor ventilation	
8 Other	

***Working with power tools and machines**

APTITUDES:	
1 Verbal	
2 Numerical	X
3 Abstract	X
4 Spatial	X
5 Clerical	X
6 Mechanical	X
7 Spelling	
8 Grammar	

PHYSICAL DEMANDS:	
1 Strength	M,H
2 Climbing, balancing	X
3 Stooping, kneeling, crawling	X
4 Manual dexterity	X
5 Talking, hearing	X
6 Visual acuity	X
7 Other	
Standing for long time periods	X

INTERESTS:	
1 Dealing with things & objects	X
2 Business contact with people	
3 Routine, system	
4 Social welfare	
5 Prestige, esteem	
6 Communication of ideas	
7 Science & technology	
8 Abstraction, creativity	
9 Machines, procedures	X
0 Tangible results	X

TEMPERAMENT:	
1 Varied duties, frequent change	
2 Repeated, set procedures	
3 Matching specified instructions	
4 Directing & planning for others	
5 Working with others	
6 Working alone & apart	
7 Influencing other people's ideas	
8 Risks, unexpected events, emergencies	
9 Making empirical judgments, decisions	
0 Analyzing facts and figures	X
X Interpreting personal feelings	
Y Precision, accuracy	X

RELATION TO:	
1 Data:	Compiling
2 People:	
3 Things:	Precision Working

The SIDING APPLICATOR

applies shingles, clapboards, exterior paneling, and other types of siding to buildings and dwellings. He uses power and hand tools to cut materials to fit to the walls.

A journeyman carpenter would have training in siding application during his apprenticeship.

LOWER LEVEL JOBS:

helper, apprentice laborer

PLACEMENT OPPORTUNITIES:

construction and repair of homes and other buildings
missile, spacecraft, aircraft manufacturing
self-employment

EMPLOYMENT OUTLOOK:

good

HOURS:

40/week

AVG. EARNINGS:

\$1.75-5.00/hour

HIGH SCHOOL COURSE OF STUDY:

1 Business Education	
2 College Preparatory	X
3 Computer Data Processing	
4 Electro Electronics	
5 Food Preparation	
6 General Piping	
7 General Woodworking	X
8 Graphic & Commercial Art	
9 Health Occupations	
0 Home Economics	
X Metals & Machines	
Y Power Mechanics	

TOTAL EDUC/TRNG REQUIREMENTS:

1 HS Grade Completed:	10
2	11 X
3	12
4	13 & 14
5 On-The-Job Training	1-1 year
6 Apprenticeship Training	
7 Post-HS Tech/Trade	
8 Business College	
9 Jr College (2 yr)	
0 College Graduate	
X Graduate School	

SPECIAL REQUIREMENTS:

Minimum age: 18
Knowledge of building codes

CONDITIONS:

1 Inside	
Outside	X
Both	
2 Cold temp	
3 Hot temp	
4 Wet, humid	
5 Noise, vibration	
6 Hazards *	X
7 Fumes	
Odors	
Toxic	
Dust	X
Poor ventilation	
8 Other	X
Working at heights	
Power machines and tools; flying chips	

APTITUDES:

1 Verbal	
2 Numerical	
3 Abstract	
4 Spatial	X
5 Clerical	X
6 Mechanical	X
7 Spelling	
8 Grammar	

PHYSICAL DEMANDS:

1 Strength	M,H
2 Climbing, balancing	X
3 Stooping, kneeling, crawling	X
4 Manual dexterity	X
5 Talking, hearing	
6 Visual acuity	X
7 Other	
Standing for long time periods	

INTERESTS:

1 Dealing with things & objects	X
2 Business contact with people	
3 Routine, system	X
4 Social welfare	
5 Prestige, esteem	
6 Communication of ideas	
7 Science & technology	
8 Abstraction, creativity	
9 Machines, procedures	X
0 Tangible results	X

TEMPERAMENT:

1 Varied duties, frequent change	
2 Repeated, set procedures	X
3 Matching specified instructions	
4 Directing & planning for others	
5 Working with others	
6 Working alone & apart	
7 Influencing other people's ideas	
8 Risks, unexpected events, emergencies	
9 Making empirical judgments, decisions	
0 Analyzing facts and figures	
X Interpreting personal feelings	
Y Precision, accuracy	X

RELATION TO:

1 Data:	
2 People:	
3 Things: Manipulating	X

The FINISH MAN

cuts, fits, and installs moldings, baseboards, door frames, doors, hardwood floors, windows, panels, porches, stairs, cornices, kitchen and bathroom cabinets (usually prefabricated) and performs a variety of other duties classed as finishing or trim work and requiring the skillful use of carpenter's tools and machines. He may also do rough work.

Training in finish work is part of the carpenter's apprenticeship.

LOWER LEVEL JOBS:
apprentice

PLACEMENT OPPORTUNITIES:
home and building construction
boatbuilding

EMPLOYMENT OUTLOOK: increasing

HOURS: 40/week

AVG. EARNINGS: \$1.75-5.00/hour

HIGH SCHOOL COURSE OF STUDY:

1 Business Education	
2 College Preparatory	
3 Computer Data Processing	
4 Electro Electronics	
5 Food Preparation	
6 General Piping	
7 General Woodworking	X
8 Graphic & Commercial Art	
9 Health Occupations	
0 Home Economics	
X Metals & Machines	
Y Power Mechanics	

TOTAL EDUC/TRNG REQUIREMENTS:

1 HS Grade Completed:	10
2	11
3	12
4	13 & 14
5 On-The-Job Training	1 year
6 Apprentice Training	
7 Post-HS Tech/Trade	
8 Business College	
9 Jr College (2 Yr)	
0 College Graduate	
X Graduate School	

SPECIAL REQUIREMENTS:

Minimum age: 16

CONDITIONS:

1 Inside	
2 Outside	
3 Both	X
4 Cold temp	
5 Hot temp	
6 Wet, humid	
7 Noise, vibration	
8 Hazards *	X
9 Fumes	
0 Odors	
X Toxic	
Y Dust	X
0 Poor ventilation	
8 Other	X
Working at heights	

***Power tools; flying chips**

APTITUDES:

1 Verbal	
2 Numerical	X
3 Abstract	
4 Spatial	X
5 Clerical	X
6 Mechanical	X
7 Spelling	
8 Grammar	

PHYSICAL DEMANDS:

1 Strength	M
2 Climbing, balancing	X
3 Stooping, kneeling, crawling	X
4 Manual dexterity	X
5 Talking, hearing	
6 Visual acuity	X
7 Other	X
Standing for long time periods	

INTERESTS:

1 Dealing with things & objects	X
2 Business contact with people	
3 Routine, system	
4 Social welfare	
5 Prestige, esteem	
6 Communication of ideas	
7 Science & technology	
8 Abstraction, creativity	
9 Machines, procedures	X
0 Tangible results	X

TEMPERAMENT:

1 Varied duties, frequent change	
2 Repeated, set procedures	
3 Matching specified instructions	
4 Directing & planning for others	
5 Working with others	
6 Working alone & apart	
7 Influencing other people's ideas	
8 Risks, unexpected events, emergencies	
9 Making empirical judgments, decisions	
0 Analyzing facts and figures	X
X Interpreting personal feelings	
Y Precision, accuracy	X

RELATION TO:

1 Data: Compiling	X
2 People:	
3 Things: Precision Working	X

The MILLMAN

fabricates such lumber products as sashes, window and door frames, doors, dressed lumber, and furniture parts. He uses hand tools and woodworking machinery, including molders, planers, shapers, and hand and power saws.

The journeyman carpenter's apprenticeship training might include some mill work.

LOWER LEVEL JOBS: helper

PLACEMENT OPPORTUNITIES:

home and building construction. maintenance, repair, remodeling work furniture manufacturing

EMPLOYMENT OUTLOOK: good

HOURS: 40/week

AVG. EARNINGS: \$1.75-4.50/week

HIGH SCHOOL COURSE OF STUDY:	
1 Business Education	
2 College Preparatory	
3 Computer Data Processing	
4 Electro Electronics	
5 Food Preparation	
6 General Piping	
7 General Woodworking	X
8 Graphic & Commercial Art	
9 Health Occupations	
0 Home Economics	
X Metals & Machines	
Y Power Mechanics	

TOTAL EDUC/TRNG REQUIREMENTS:	
1 HS Grade Completed:	10
2	11
3	12
4	13 & 14
5 On-The-Job Training	6 mo.
6 Apprenticeship Training	
7 Post-'3 Tech/Trade	
8 Business College	
9 Jr College (2 yr)	
0 College Graduate	
X Graduate School	

SPECIAL REQUIREMENTS:	
Minimum age:	18

CONDITIONS:	
1 Inside	X
Outside	
Both	
2 Cold temp	
3 Hot temp	
4 Wet, humid	
5 Noise, vibration	X
6 Hazards *	X
7 Fumes	
Odors	
Toxic	
Dust	X
Poor ventilation	
8 Other	

***Power tools & machines; flying chips**

APTITUDES:	
1 Verbal	
2 Numerical	X
3 Abstract	
4 Spatial	X
5 Clerical	X
6 Mechanical	X
7 Spelling	
8 Grammar	

PHYSICAL DEMANDS:	
1 Strength	M,H
2 Climbing, balancing	
3 Stooping, kneeling, crawling	
4 Manual dexterity	X
5 Talking, hearing	
6 Visual acuity	X
7 Other	
Standing for long time periods	X

INTERESTS:	
1 Dealing with things & objects	
2 Business contact with people	
3 Routine, system	
4 Social welfare	
5 Prestige, esteem	
6 Communication of ideas	
7 Science & technology	
8 Abstraction, creativity	X
9 Machines, procedures	X
0 Tangible results	X

TEMPERAMENT:	
1 Varied duties, frequent change	X
2 Repeated, set procedures	
3 Matching specified instructions	
4 Directing & planning for others	
5 Working with others	
6 Working alone & apart	
7 Influencing other people's ideas	
8 Risks, unexpected events, emergencies	
9 Making empirical judgments, decisions	
0 Analyzing facts and figures	X
X Interpreting personal feelings	
Y Precision, accuracy	X

RELATION TO:	
1 Data: Compiling	X
2 People:	
3 Things: Setting-Up	X

The BOATBUILDER

constructs, finishes, repairs, maintains, or remodels small wooden or plastic boats, floats, and pontoons. Highly skilled carpentry operations are involved in assembling hulls, laying decks, and installing other parts and members. In addition, he finishes and installs spars, masts, hardware, etc. He may also supervise the work of helpers.

LOWER LEVEL JOBS: helper.

PLACEMENT OPPORTUNITIES:

boat factories
retail and custom boat yards
self-employment

EMPLOYMENT OUTLOOK:

good, depending on continued prosperity

HOURS: 40/week

AVG. EARNINGS: \$1.75-5.00/hour

HIGH SCHOOL COURSE OF STUDY:

1	Business Education	
2	College Preparatory	
3	Computer Data Processing	
4	Electro Electronics	
5	Food Preparation	
6	General Piping	
7	General Woodworking	X
8	Graphic & Commercial Art	
9	Health Occupations	
0	Home Economics	
X	Metals & Machines	
Y	Power Mechanics	

TOTAL EDUC/TRNG REQUIREMENTS:

1	HS Grade Completed:	10
2		11
3		12
4		13 & 14
5	On-The-Job Training	1-2 years
6	Apprentice Training	
7	Post-HS Tech/Trade	
8	Business College	
9	Jr College (2 yr)	
0	College Graduate	
X	Graduate School	

SPECIAL REQUIREMENTS:

Minimum age: 18

CONDITIONS:

1	Inside	
	Outside	
	Both	X
2	Cold temp	
3	Hot temp	
4	Wet, humid	
5	Noise, vibration	
6	Hazards *	X
7	Fumes	
	Odors	
	Toxic	X
	Dust	X
	Poor ventilation	
8	Other	

* **Power machines and tools; flying chips**

APTITUDES:

1	Verbal	
2	Numerical	X
3	Abstract	
4	Spatial	X
5	Clerical	X
6	Mechanical	X
7	Spelling	
8	Grammar	

PHYSICAL DEMANDS:

1	Strength	M,H
2	Climbing, balancing	X
3	Stooping, kneeling, crawling	X
4	Manual dexterity	X
5	Talking, hearing	
6	Visual acuity	X
7	Other	

INTERESTS:

1	Dealing with things & objects	X
2	Business contact with people	
3	Routine, system	
4	Social welfare	
5	Prestige, esteem	
6	Communication of ideas	
7	Science & technology	
8	Abstraction, creativity	
9	Machines, procedures	X
0	Tangible results	X

TEMPERAMENT:

1	Varied duties, frequent change	
2	Repeated, set procedures	
3	Matching specified instructions	
4	Directing & planning for others	
5	Working with others	
6	Working alone & apart	
7	Influencing other people's ideas	
8	Risks, unexpected events, emergencies	
9	Making empirical judgments, decisions	
0	Analyzing facts and figures	X
X	Interpreting personal feelings	
Y	Precision, accuracy	X

RELATION TO:

1	Data: Compiling	X
2	People:	
3	Things: Precision Working	X

The CONSTRUCTION TECHNICIAN

supervises construction projects. He must be familiar with carpentry, electrical, plumbing, masonry, and sheet metal work. He reads and interprets blueprints, computes cost and time estimates, schedules work forces, issues tools and materials, checks on progress and verifies quality of work against specifications. He may have to overcome production problems which would interfere with the time schedule or man-hour efficiency.

HIGH SCHOOL COURSE OF STUDY:

1 Business Education	
2 College Preparatory	
3 Computer Data Processing	
4 Electro Electronics	
5 Food Preparation	
6 General Piping	
7 General Woodworking	X
8 Graphic & Commercial Art	
9 Health Occupations	
0 Home Economics	
X Metals & Machines	
Y Power Mechanics	

RELATED JOBS: lister

LOWER LEVEL JOBS:

- carpenter
- electrician
- plumber
- bricklayer
- sheet metal worker

PLACEMENT OPPORTUNITIES:

home and building construction and remodeling
federal governmental agencies
railroad, bridge, highway construction; boatbuilding

EMPLOYMENT OUTLOOK: moderate

HOURS: 40/week

AVG. EARNINGS: \$5.00-7.00/hour

TOTAL EDUC/TRNG REQUIREMENTS:

1 HS Grade Completed:	10
2	11
3	12
4	13 & 14 X
5 On-The-Job Training	5-7 years
6 Apprentice Training	
7 Post-HS Tech/Trade	
8 Business College	
9 Jr College (2 yr)	
0 College Graduate	
X Graduate School	

SPECIAL REQUIREMENTS:

Minimum age: 18
Knowledge of building codes

CONDITIONS:

1 Inside	
Outside	
Both	X
2 Cold temp	
3 Hot temp	
4 Wet, humid	
5 Noise, vibration	
6 Hazards *	X
7 Fumes	
Odors	
Toxic	
Dust	X
Poor ventilation	X
8 Other	X
Working at heights	
* Falling objects	

APTITUDES:

1 Verbal	X
2 Numerical	X
3 Abstract	X
4 Spatial	X
5 Clerical	X
6 Mechanical	X
7 Spelling	
8 Grammar	X

PHYSICAL DEMANDS:

1 Strength	M-H
2 Climbing, balancing	X
3 Stooping, kneeling, crawling	X
4 Manual dexterity	X
5 Talking, hearing	X
6 Visual acuity	X
7 Other	

INTERESTS:

1 Dealing with things & objects	
2 Business contact with people	X
3 Routine, system	
4 Social welfare	
5 Prestige, esteem	
6 Communication of ideas	X
7 Science & technology	X
8 Abstraction, creativity	
9 Machines, procedures	X
0 Tangible results	

TEMPERAMENT:

1 Varied duties, frequent change	X
2 Repeated, set procedures	
3 Matching specified instructions	
4 Directing & planning for others	X
5 Working with others	X
6 Working alone & apart	
7 Influencing other people's ideas	X
8 Risks, unexpected events, emergencies	
9 Making empirical judgments, decisions	X
0 Analyzing facts and figures	X
X Interpreting personal feelings	
Y Precision, accuracy	X

RELATION TO:

- 1 Data: Coordinating X
- 2 People: Supervising X
- 3 Things: Precision-Working X

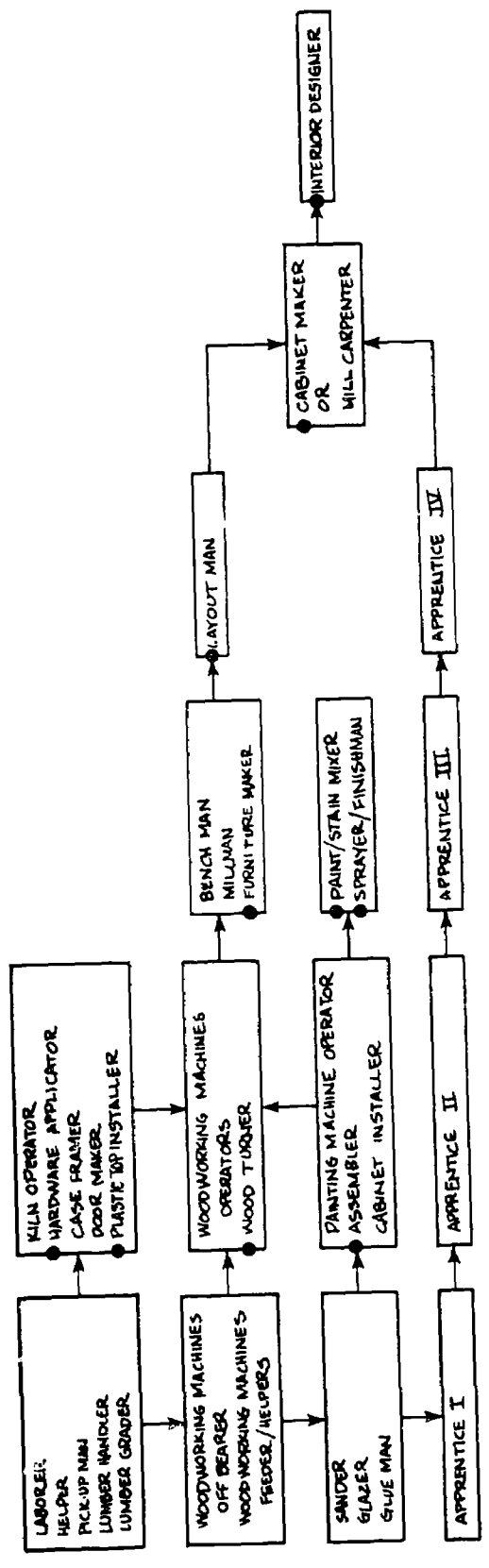

GENERAL WOODWORKING
MILL CARPENTRY

● SELECTED JOBS

GENERAL WOODWORKING: MILL CARPENTRY

Furniture and cabinets have developed from crude, simple designs of years ago to the many beautiful styles available today. All of the cutting and carving of these furnishings used to be done by hand, but to meet today's demands for quantity, much of the work is now done by machine. Similarly, many cabinet units are now constructed in the mill or shop and then taken to the building site to be installed.

Whether doing production or custom work, the journeyman mill carpenter or cabinetmaker must be knowledgeable in wood characteristics, drafting and layout work, assembling and finishing operations. He must also be skilled in the operation and care of the hand and machine tools used in woodworking.

High school graduation or its equivalent is required for entering apprenticeship program for mill carpentry, and vocational-technical training in these skills will be credited as part of the time in apprenticeship. In this locality, however, apprenticeship opportunities are scarce and many of these craftsmen depend on on-the-job training to supplement their initial technical training.

Although prefabrication will have some effect on the employment outlook in this field, a skilled furniture or cabinetmaker can nearly always find work. Also, woodworking is rewarding not only as a vocation but to make things for personal or home use.

AREA General Woodworking

SUB FAMILY Mill Carpentry

JOB Assembler

D.O.T. 763.884

(D.O.T.: Furniture Assembler)

The ASSEMBLER

working from a layout or blueprint, assembles furniture, fixtures, cabinets, etc., using clamps, squares, jigs, glue, etc.

Assembling is a unit in the mill carpenter's apprenticeship training.

RELATED JOBS:

subassembly man
top-case assembler

LOWER LEVEL JOBS:

helper

PLACEMENT OPPORTUNITIES:

home and building construction
furniture manufacturing
custom and job shops

EMPLOYMENT OUTLOOK:

good
HOURS: 40/week

AVG. EARNINGS: \$1.50-3.00/hour

HIGH SCHOOL COURSE OF STUDY:

1 Business Education	
2 College Preparatory	
3 Computer Data Processing	
4 Electro Electronics	
5 Food Preparation	
6 General Piping	
7 General Woodworking	X
8 Graphic & Commercial Art	
9 Health Occupations	
0 Home Economics	
X Metals & Machinis	
Y Power Mechanics	

TOTAL EDUC/TRNG REQUIREMENT:

1 HS Grade Completed:	10	X
2	11	
3	12	
4	13 & 14	
5 On-The-Job Training:	1	year
6 Apprentices Training		
7 Post-HS Tech/Trade		
8 Business College		
9 Jr College (2 yr)		
0 College Graduate		
X Graduate School		

APTITUDES:

1 Verbal	
2 Numerical	
3 Abstract	X
4 Spatial	X
5 Clerical	X
6 Mechanical	X
7 Spelling	
8 Grammar	

SPECIAL REQUIREMENTS:

Minimum age: 16

CONDITIONS:

1 Inside	X
Outside	
Both	
2 Cold temp	
3 Hot temp	
4 Wet, humid	
5 Noise, vibration	
6 Hazards*	X
7 Fumes	
Odors	
Toxic	
Dust	
Poor ventilation	
Other	X
Work area sometimes messy	

*Falling clamps

1 Verbal	
2 Numerical	
3 Abstract	X
4 Spatial	X
5 Clerical	X
6 Mechanical	X
7 Spelling	
8 Grammar	

PHYSICAL DEMANDS:

1 Strength	L,M
2 Climbing, balancing	
3 Stooping, kneeling, crawling	X
4 Manual dexterity	X
5 Talking, hearing	
6 Visual acuity	X
7 Other	
Standing for long time periods	

INTERESTS:

1 Dealing with things & objects	X
2 Business contact with people	
3 Routine, system	X
4 Social welfare	
5 Prestige, esteem	
6 Communication of ideas	
7 Science & technology	
8 Abstraction, creativity	
9 Machines, procedures	X
0 Tangible results	X

TEMPERAMENT:

1 Varied duties, frequent change	
2 Repeated, set procedures	X
3 Matching specified instructions	
4 Directing & planning for others	
5 Working with others	
6 Working alone & apart	
7 Influencing other people's ideas	
8 Risks, unexpected events, emergencies	
9 Making empirical judgments, decisions	
0 Analyzing facts and figures	
X Interpreting personal feelings	
Y Precision, accuracy	X

RELATION TO:

1 Data:	
2 People:	
3 Things: Manipulating	X

HARDWARE APPLICATOR

attaches hardware (handles, locks, ornaments) to finished furniture and cabinets. He also applies reinforcing metal clips to drawers and door frames.

Hardware application is a unit in the carpenter's apprenticeship training.

LOWER LEVEL JOBS: helper

PLACEMENT OPPORTUNITIES:

home and building construction furniture manufacturing custom and job shops boatbuilding

EMPLOYMENT OUTLOOK: good

HOURS: 40/week

AVG. EARNINGS: \$1.50-2.50/hour

HIGH SCHOOL COURSE OF STUDY:	
1 Business Education	
2 College Preparatory	
3 Computer Data Processing	
4 Electro Electronics	
5 Food Preparation	
6 General Piping	
7 General Woodworking	X
8 Graphic & Commercial Art	
9 Health Occupations	
0 Home Economics	
X Metals & Machines	
Y Power Mechanics	

TOTAL EDUC/TRNG REQUIREMENTS:	
1 HS Grade Completed:	10 X
2	11
3	12
4	13 & 14
5 On-The-Job Training	
6 Apprentice Training	
7 Post-HS Tech/Trade	
8 Business College	
9 Jr College (2 yr)	
0 College Graduate	
X Graduate School	

SPECIAL REQUIREMENTS:	
Minimum age:	16

CONDITIONS:	
1 Inside	X
Outside	
Both	
2 Cold temp	
3 Hot temp	
4 Wet, humid	
5 Noise, vibration	
6 Hazards (tools)	X
7 Fumes	
Odors	
Toxic	
Dust	X
Poor ventilation	
8 Other	

APTITUDES:	
1 Verbal	
2 Numerical	
3 Abstract	
4 Spatial	X
5 Clerical	X
6 Mechanical	X
7 Spelling	
8 Grammar	

PHYSICAL DEMANDS:	
1 Strength	L
2 Climbing, balancing	
3 Stooping, kneeling, crawling	X
4 Manual dexterity	X
5 Talking, hearing	
6 Visual acuity	X
7 Other	
Standing for long time periods	

INTERESTS:	
1 Dealing with things & objects	X
2 Business contact with people	
3 Routine, system	X
4 Social welfare	
5 Prestige, esteem	
6 Communication of ideas	
7 Science & technology	
8 Abstraction, creativity	
9 Machines, procedures	X
0 Tangible results	X

TEMPERAMENT:	
1 Varied duties, frequent change	
2 Repeated, set procedures	X
3 Matching specified instructions	
4 Directing & planning for others	
5 Working with others	
6 Working alone & apart	
7 Influencing other people's ideas	
8 Risks, unexpected events, emergencies	
9 Making empirical judgments, decisions	
0 Analyzing facts and figures	
X Interpreting personal feelings	
Y Precision, accuracy	X

RELATION TO:	
1 Data:	
2 People:	
3 Things: Manipulating	X

The WOOD TURNER

cuts specified designs of furniture parts, automatic lathe patterns, and other circular cross-section pieces by holding hand tools against wood stock rotating in a lathe. After measuring and marking, he cuts the cylinder to shape using appropriate chisels and checking occasionally with calipers.

Woodturning is included in the mill carpentry apprenticeship training.

PLACEMENT OPPORTUNITIES:

furniture manufacturing cabinet, mill, and captive shops
toy manufacturing
self-employment

EMPLOYMENT OUTLOOK: good

HOURS: 40/week

EARNINGS: \$1.75-3.50/hour

HIGH SCHOOL COURSE OF STUDY:

1	Business Education	
2	College Preparatory	
3	Computer Data Processing	
4	Electro Electronics	
5	Food Preparation	
6	General Piping	
7	General Woodworking	X
8	Graphic & Commercial Art	
9	Health Occupations	
10	Home Economics	
X	Metals & Machines	
Y	Power Mechanics	

TOTAL EDUC/TRNG REQUIREMENTS:

1	HS Grade Completed:	10	X
2		11	
3		12	
4		3 & 14	
5	On-The-Job Training	1 year	
6	Apprentice Training		
7	Post-HS Tech/Trade		
8	Business College		
9	Jr College (2 yr)		
10	College Graduate		
X	Graduate School		

SPECIAL REQUIREMENTS:

Minimum age: 18

CONDITIONS:

1	Inside	X
	Outside	
	Both	
2	Cold temp	
3	Hot temp	
4	Wet, humid	
5	Noise, vibration	
6	Hazards*	X
7	Fumes	
	Odors	
	Toxic	
	Dust	X
	Floor ventilation	
	Other	

*Power tools, machines, flying chips

APTITUDES:

1	Verbal	
2	Numerical	
3	Abstract	
4	Spatial	X
5	Clerical	X
6	Mechanical	X
7	Spelling	
8	Grammar	

PHYSICAL DEMANDS:

1	Strength	L,M
2	Climbing, balancing	
3	Stooping, kneeling, crawling	
4	Manual dexterity	X
5	Talking, hearing	
6	Visual acuity	X
7	Other	

Standing for long time periods

INTERESTS:

1	Dealing with things & objects	X
2	Business contact with people	
3	Routine, system	
4	Social welfare	
5	Prestige, esteem	
6	Communication of ideas	
7	Science & technology	
8	Abstraction, creativity	
9	Machines, procedures	X
10	Tangible results	

TEMPERAMENT:

1	Varied duties, frequent change	
2	Repeated, set procedures	
3	Matching specified instructions	
4	Directing & planning for others	
5	Working with others	
6	Working alone & apart	
7	Influencing other people's ideas	
8	Risks, unexpected events, emergencies	
9	Making empirical judgments, decisions	
10	Analyzing facts and figures	X
X	Interpreting personal feelings	
Y	Precision, accuracy	X

RELATION TO:

1	Data:	
2	People:	
3	Things: Operating-Controlling	X

The PLASTIC-TOP INSTALLER

applies plastic sheeting (e.g. Formica) to furniture, cabinets, counters, etc., trimming rough or extruding pieces.

Installing plastic is usually one of the cabinetmaker's tasks but with so much furniture being plastic-veneered today, large manufacturers employ men who specialize in this work.

LOWER LEVEL JOBS:

bench hand, helper

PLACEMENT OPPORTUNITIES:

home and building construction furniture manufacturing custom and job shops

EMPLOYMENT OUTLOOK: good

HOURS: 40/week

AVG. EARNINGS: \$1.50-3.50/hour

HIGH SCHOOL COURSE OF STUDY:	
1	Business Education
2	College Preparatory
3	Computer Data Processing
4	Electro Electronics
5	Food Preparation
6	General Piping
7	General Woodworking X
8	Graphic & Commercial Art
9	Health Occupations
10	Home Economics
X	Metals & Machines
Y	Power Mechanics

TOTAL EDUC/TRNG REQUIREMENTS:	
1	HS Grade Completed: 10 X
2	11
3	12
4	13 & 14
5	On-The-Job Training 1 year
6	Apprentice Training
7	Post-HS Tech/Trade
8	Business College
9	Jr College (2 yr)
10	College Graduate
X	Graduate School

SPECIAL REQUIREMENTS:	
Minimum age: 18	

CONDITIONS:	
1	Inside X
	Outside
	Both
2	Cold temp
3	Hot temp
4	Wet, humid
5	Noise, vibration
6	Hazards* X
7	Fumes
	Odors
	Toxic X
	Dust X
	Poor ventilation
8	Other
	*Cutting machines; flying chips

APTITUDES:	
1	Verbal
2	Numerical
3	Abstract
4	Spatial X
5	Clerical X
6	Mechanical X
7	Spelling
8	Grammar

PHYSICAL DEMANDS:	
1	Strength L,M
2	Climbing, balancing
3	Stooping, kneeling, crawling
4	Manual dexterity X
5	Talking, hearing
6	Visual acuity X
7	Other

INTERESTS:	
1	Dealing with things & objects X
2	Business contact with people
3	Routine, system X
4	Social welfare
5	Prestige, esteem
6	Communication of ideas
7	Science & technology
8	Abstraction, creativity
9	Machines, procedures X
10	Tangible results X

TEMPERAMENT:	
1	Varied duties, frequent change
2	Repeated, set procedures X
3	Matching specified instructions
4	Directing & planning for others
5	Working with others
6	Working alone & apart
7	Influencing other people's ideas
8	Risks, unexpected events, emergencies
9	Making empirical judgments, decisions
10	Analyzing facts and figures
X	Interpreting personal feelings
Y	Precision, accuracy X

RELATION TO:	
1	Data:
2	People:
3	Things: Manipulating X

The PAINT AND STAIN MIXER

prepares stains, paints, and other coatings to color specifications. He also blends colors to get custom shades. He may also test specific gravity of the mixture using a hydrometer.

Large shops employ men who do nothing but mix paints and stains; in small shops the painter and sprayer also does the mixing. It is also a unit in mill carpentry apprenticeship training.

LOWER LEVEL JOBS:

painter and sprayer apprentice

PLACEMENT OPPORTUNITIES:

furniture manufacturing
cabinet shops
machine manufacturing
boatbuilding

EMPLOYMENT OUTLOOK: good

HOURS: 40/week

EARNINGS: \$1.50-3.50/hour

HIGH SCHOOL COURSE OF STUDY:

1 Business Education	
2 College Preparatory	
3 Computer Data Processing	
4 Electro Electronics	
5 Food Preparation	
6 General Piping	
7 General Woodworking	X
8 Graphic & Commercial Art	
9 Health Occupations	
10 Home Economics	
X Metals & Machines	
Y Power Mechanics	

TOTAL EDUC/TRNG REQUIREMENTS:

1 HS Grade Completed:	10
2	11 X
3	12
4	13 & 14
5 On-The-Job Training	1 year
6 Apprentice Training	
7 Post-HS Tech/Trade	
8 Business College	
9 Jr College (2 yr)	
10 College Graduate	
X Graduate School	

SPECIAL REQUIREMENTS:

Minimum age: 18

CONDITIONS:

1 Inside	X
Outside	
Both	
2 Cold temp	
3 Hot temp	
4 Wet, humid	
5 Noise, vibration	
6 Hazards	
7 Fumes	X
Odors	X
Toxic	
Dust	
Poor ventilation	
3 Other	X
Dirty conditions sometimes	

APTITUDES:

1 Verbal	
2 Numerical	
3 Abstract	
4 Spatial	X
5 Clerical	X
6 Mechanical	X
7 Spelling	
8 Grammar	

PHYSICAL DEMANDS:

1 Strength	L
2 Climbing, balancing	
3 Stooping, kneeling, crawling	
4 Manual dexterity	X
5 Talking, hearing	
6 Visual acuity	X
7 Other	

INTERESTS:

1 Dealing with things & objects	X
2 Business contact with people	
3 Routine, system	X
4 Social welfare	
5 Prestige, esteem	
6 Communication of ideas	
7 Science & technology	
8 Abstraction, creativity	
9 Machines, procedures	X
10 Tangible results	

TEMPERAMENT:

1 Varied duties, frequent change	
2 Repeated, set procedures	X
3 Matching specified instructions	X
4 Directing & planning for others	
5 Working with others	
6 Working alone & apart	
7 Influencing other people's ideas	
8 Risks, unexpected events, emergencies	
9 Making empirical judgments, decisions	
10 Analyzing facts and figures	
X Interpreting personal feelings	
Y Precision, accuracy	X

RELATION TO:

1 Data:	
2 People:	
3 Things: Tending	X

REA General Woodworking

SUB FAMILY Mill Carpentry

JOB Sprayer and Finish Man
(D.O.T.: Furniture Finisher)

D.O.T. 763.381

The SPRAYER AND FINISH MAN

applies paint, varnish, and other coatings to parts or completed pieces of wood and metal furniture. He sands between successive coats and after the final coat is dry rubs with pumice or polishes with wax.

Finishing is a unit in the apprenticeship training in mill carpentry.

LOWER LEVEL JOBS:

apprentice, helper

PLACEMENT OPPORTUNITIES:

furniture manufacturing
retail stores selling furniture
custom and captive shops
machine manufacturing

EMPLOYMENT OUTLOOK:

good

HOURS:

40/week

EARNINGS:

\$1.50-3.50/hour

HIGH SCHOOL COURSE OF STUDY:

1	Business Education	
2	College Preparatory	
3	Computer Data Processing	
4	Electro Electronics	
5	Food Preparation	
6	General Piping	
7	General Woodworking	X
8	Graphic & Commercial Art	
9	Health Occupations	
0	Home Economics	
X	Metals & Machines	
	Power Mechanics	

TOTAL EDUC/TRNG REQUIREMENTS:

1	HS Grade Completed:	10
2		11
3		12
4		13 & 14
5	On-The-Job Training	1 year
6	Apprentice Training	
7	Post-HS Tech./Trade	
8	Business College	
9	Jr College (2 yr)	
0	College Graduate	
X	Graduate School	

SPECIAL REQUIREMENTS:

Minimum age:	16
---------------------	----

CONDITIONS:

1	Inside	X
	Outside	
	Both	
2	Cold temp	
3	Hot temp	
4	Wet, humid	
5	Noise, vibration	
6	Hazards	
7	Fumes	
	Odors	X
	Toxic	X
	Dust	
	Poor ventilation	
8	Other	X
	Dirty conditions	
	sometimes	

APTITUDES:

1	Verbal	
2	Numerical	X
3	Abstract	
4	Spatial	X
5	Clerical	X
6	Mechanical	X
7	Spelling	
8	Grammar	

PHYSICAL DEMANDS:

1	Strength	L
2	Climbing, balancing	
3	Stooping, kneeling, crawling	X
4	Manual dexterity	X
5	Talking, hearing	
6	Visual acuity	X
7	Other	
	Standing for long time periods	

INTERESTS:

1	Dealing with things & objects	X
2	Business contact with people	
3	Routine, system	
4	Social welfare	
5	Prestige, esteem	
6	Communication of ideas	
7	Science & technology	
8	Abstraction, creativity	
9	Machines, procedures	X
0	Tangible results	X

TEMPERAMENT:

1	Varied duties, frequent change	
2	Repeated, set procedures	
3	Matching specified instructions	
4	Directing & planning for others	
5	Working with others	
6	Working alone & apart	
7	Influencing other people's ideas	
8	Risks, unexpected events, emergencies	
9	Making empirical judgments, decisions	
0	Analyzing facts and figures	X
X	Interpreting personal feelings	
Y	Precision, accuracy	X

RELATION TO:

1	Data: Compiling	X
2	People:	
3	Things: Precision Working	X

The FURNITURE MAKER

cuts out parts of furniture and assembles them as either complete units or subassemblies. He must be proficient with both hand and power tools. He may also repair and maintain furniture.

RELATED JOBS:
furniture reproducer

LOWER LEVEL JOBS:

helper, apprentice wood turner assembler hardware applicator plastic-top installer sprayer and finish man paint and stain mixer

PLACEMENT OPPORTUNITIES:

home and building construction cabinet and captive shops

EMPLOYMENT OUTLOOK: good

HOURS: 40/week

EARNINGS: \$1.75-4.50/hour

HIGH SCHOOL COURSE OF STUDY:

1 Business Education	
2 College Preparatory	
3 Computer Data Processing	
4 Electro Electronics	
5 Food Preparation	
6 General Piping	
7 General Woodworking	X
8 Graphic & Commercial Art	
9 Health Occupations	
10 Home Economics	
11 Metals & Machines	
12 Power Mechanics	

TOTAL EDUC/TRNS REQUIREMENTS:

1 HS Grade Completed:	10
2	11 X
3	12
4	13 & 14
5 On-The-Job Training	2 years
6 Apprentices Training	
7 Post-HS Tech/Trade	
8 Business College	
9 Jr College (2 yr)	
10 College Graduate	
11 Graduate School	

SPECIAL REQUIREMENTS:

Minimum age: 18

CONDITIONS:

1 Inside	X
2 Outside	
3 Both	
4 Cold temp	
5 Hot temp	
6 Wet, humid	
7 Noise, vibration	
8 Hazards *	X
9 Fumes	
10 Odors	
11 Toxic	
12 Dust	X
13 Poor ventilation	
14 Other	X
15 Dirty conditions sometimes	

*Power tools; flying chips

APTITUDES:

1 Verbal	
2 Numerical	X
3 Abstract	
4 Spatial	X
5 Clerical	X
6 Mechanical	X
7 Spelling	
8 Grammar	

PHYSICAL DEMANDS:

1 Strength	L,M
2 Climbing, balancing	
3 Stooping, kneeling, crawling	
4 Manual dexterity	X
5 Talking, hearing	
6 Visual acuity	X
7 Other	
8 Standing for long time periods	

INTERESTS:

1 Dealing with things & objects	
2 Business contact with people	
3 Routine, system	
4 Social welfare	
5 Prestige, esteem	
6 Communication of ideas	
7 Science & technology	
8 Abstraction, creativity	
9 Machines, procedures	X
10 Tangible results	X

TEMPERAMENT:

1 Varied duties, frequent change	X
2 Repeated, set procedures	
3 Matching specified instructions	
4 Directing & planning for others	
5 Working with others	
6 Working alone & apart	
7 Influencing other people's ideas	
8 Risks, unexpected events, emergencies	
9 Making empirical judgments, decisions	
10 Analyzing facts and figures	X
11 Interpreting personal feelings	
12 Precision, accuracy	X

RELATION TO:

1 Data: Analyzing	X
2 People:	
3 Things: Setting-up	X

The KITCHEN CABINETMAKER

constructs upper and lower kitchen cabinets to stock or custom specifications, using hand and power woodworking tools. He also applies plastic tops on counters, using plastic cutting machines.

RELATED JOBS:
refrigerator cabinetmaker

LOWER LEVEL JOBS:
helper, apprentice wood turner

assembler
hardware applicator
plastic-top installer
layout man
finish man
paint and stain mixer

PLACEMENT OPPORTUNITIES:
captive, job shops
self-employment

EMPLOYMENT OUTLOOK: good

HOURS: 40/week

AVG. EARNINGS: \$1.75-4.50/hour

HIGH SCHOOL COURSE OF STUDY:

1 Business Education	
2 College Preparatory	
3 Computer Data Processing	
4 Electro Electronics	
5 Food Preparation	
6 General Piping	
7 General Woodworking	X
8 Graphic & Commercial Art	
9 Health Occupations	
10 Home Economics	
X Metals & Machines	
Y Power Mechanics	

TOTAL EDUC/TRNG REQUIREMENTS:

1 HS Grade Completed:	10
2	11
3	12
4	13 & 14
5 On-The-Job Training	1 year
6 Apprentice Training	
7 Post-HS Tech/Trade	
8 Business College	
9 Jr College (2 yr)	
10 College Graduate	
X Graduate School	

SPECIAL REQUIREMENTS:

Minimum age 18

CONDITIONS:

1 Inside	X
Outside	
Both	
2 Cold temp	
3 Hot temp	
4 Wet, humid	
5 Noise, vibration	
6 Hazards*	X
7 Fumes	
Odors	
Toxic	X
Dust	X
Poor ventilation	
8 Other	

*Power tools, machines; flying chips

APTITUDES:

1 Verbal	
2 Numerical	X
3 Abstract	
4 Spatial	X
5 Clerical	X
6 Mechanical	X
7 Spelling	
8 Grammar	

PHYSICAL DEMANDS:

1 Strength	M,H
2 Climbing, balancing	
3 Stooping, kneeling, crawling	X
4 Manual dexterity	X
5 Talking, hearing	
6 Visual acuity	X
7 Other	

Standing for long time periods

INTERESTS:

1 Dealing with things & objects	
2 Business contact with people	
3 Routine, system	
4 Social welfare	
5 Prestige, esteem	
6 Communication of ideas	
7 Science & technology	
8 Abstraction, creativity	
9 Machines, procedures	X
10 Tangible results	X

TEMPERAMENT:

1 Varied duties, frequent change	X
2 Repeated, set procedures	
3 Matching specified instructions	
4 Directing & planning for others	
5 Working with others	
6 Working alone & apart	
7 Influencing other people's ideas	
8 Risks, unexpected events, emergencies	
9 Making empirical judgments, decisions	
10 Analyzing facts and figures	X
X Interpreting personal feelings	
Y Precision, accuracy	X

RELATION TO:

1 Data: Analyzing	X
2 People:	
3 Things: Setting-up	X

The LAYOUT MAN

in mill carpentry marks on stock lumber the outlines of frames, furniture parts, and other wood sections to guide the machine operators, arranging the cardboard or wood patterns so as to obtain the most effective utilization of wood grain.

Training in layout work is part of the apprenticeship program for a journeyman mill carpenter.

LOWER LEVEL JOBS: bench hand

PLACEMENT OPPORTUNITIES:

home and building construction
furniture manufacturing
custom and job shops
boatbuilding

EMPLOYMENT OUTLOOK: good

HOURS: 40/week

AVG. EARNINGS: \$1.75-4.50/hour

HIGH SCHOOL COURSE OF STUDY:

1 Business Education	
2 College Preparatory	
3 Computer Data Processing	
4 Electro Electronics	
5 Food Preparation	
6 General Piping	
7 General Woodworking	X
8 Graphic & Commercial Art	
9 Health Occupations	
0 Home Economics	
X Metals & Machines	
Y Power Mechanics	

TOTAL EDUC/TRNG REQUIREMENTS:

1 HS Grade Completed:	10
2	11
3	12 X
4	13 & 14
5 On-The-Job Training	1-2 years
6 Apprentices Training	
7 Post-HS Tech/Trade	
8 Business College	
9 Jr College (2 yr)	
0 College Graduate	
X Graduate School	

SPECIAL REQUIREMENTS:

Minimum age: 16

CONDITIONS:

1 Inside	X
2 Outside	
3 Both	
4 Cold temp	
5 Hot temp	
6 Wet, humid	
7 Noise, vibration	
8 Hazards *	X
9 Fumes	
0 Odors	
X Toxic	
Y Dust	X
0 Poor ventilation	
9 Other	

*Power tools, machines

APTITUDES:

1 Verbal	
2 Numerical	X
3 Abstract	
4 Spatial	X
5 Clerical	X
6 Mechanical	X
7 Spelling	
8 Grammar	

PHYSICAL DEMANDS:

1 Strength	L
2 Climbing, balancing	
3 Stooping, kneeling, crawling	X
4 Manual dexterity	X
5 Talking, hearing	
6 Visual acuity	X
7 Other	
Standing for long time periods	

INTERESTS:

1 Dealing with things & objects	X
2 Business contact with people	
3 Routine, system	
4 Social welfare	
5 Prestige, esteem	
6 Communication of ideas	
7 Science & technology	
8 Abstraction, creativity	
9 Machines, procedures	X
0 Tangible results	X

TEMPERAMENT:

1 Varied duties, frequent change	
2 Repeated, set procedures	
3 Matching specified instructions	
4 Directing & planning for others	
5 Working with others	
6 Working alone & apart	
7 Influencing other people's ideas	
8 Risks, unexpected events, emergencies	
9 Making empirical judgments, decisions	
0 Analyzing facts and figures	X
X Interpreting personal feelings	
Y Precision, accuracy	X

RELATION TO:

1 Data: Compiling	X
2 People:	
3 Things: Precision Working	X

AREA General Woodworking

SUB FAMILY Mill Carpentry

JOB Interior Designer

D.O.T. 142.051

INTERIOR DESIGNER

The interior designer works on design projects for the interior of homes and buildings, both new and old. He makes drawings and sketches of room layouts, including fixtures and equipment (e.g. counters, cabinets, display cases); calculates cost of construction and installation; submits plans and estimates to customer for approval; arranges for completion of the project, including purchasing and sometimes the manufacturing of furnishings and materials; supervises the craftsmen performing the work (e.g. cabinetmaker, floor finisher). Some interior designers also design furniture and accessories.

RELATED JOBS:

interior decorator

LOWER LEVEL JOBS:carpenter
cabinetmaker
furniture makerPLACEMENT OPPORTUNITIES:large department stores
architects
industrial designers
hotels and restaurants
repair and remodeling work
furniture manufacturers, wholesalers, retailers
self-employmentEMPLOYMENT OUTLOOK: goodHOURS: 40/week; may be irregularAVG. EARNINGS: \$5.00-7.00/hour; some make more

HIGH SCHOOL COURSE OF STUDY:	
1 Business Education	
2 College Preparatory	
3 Computer Data Processing	
4 Electro-Electronics	
5 Food Preparation	
6 General Piping	
7 General Woodworking	X
8 Graphic & Commercial Art	
9 Health Occupations	
0 Home Economics	
X Metals & Machines	
Y Power Mechanics	

TOTAL EDUC/TRNG REQUIREMENTS:

1 HS Grade Completed:	10
2	11
3	12
4	3 & 14 X
5 On-The-Job Training	4 years
6 Apprentice Training	
7 Post-HS Tech/Trade	
8 Business College	
9 Jr College (2 yr)	
0 College Graduate	
X Graduate School	

SPECIAL REQUIREMENTS:

CONDITIONS:	
1 Inside	X
Outside	
Both	
2 Cold temp	
3 Hot temp	
4 Wet, humid	
5 Noise, vibration	
6 Hazards	
7 Fumes	
Odors	
Toxic	
Dust	X
Poor ventilation	
8 Other	X
May have irregular hours; may travel	

APTITUDES:

1 Verbal	X
2 Numerical	X
3 Abstract	X
4 Spatial	X
5 Clerical	X
6 Mechanical	X
7 Spelling	
8 Grammar	X

PHYSICAL DEMANDS:

1 Strength	S/L
2 Climbing, balancing	
3 Stooping, kneeling, crawling	
4 Manual dexterity	X
5 Talking, hearing	X
6 Visual acuity	X
7 Other	

INTERESTS:	
1 Dealing with things & objects	
2 Business contact with people	X
3 Routine, system	
4 Social welfare	
5 Prestige, esteem	
6 Communication of ideas	X
7 Science & technology	
8 Abstraction, creativity	X
9 Machines, procedures	
0 Tangible results	

TEMPERAMENT:

1 Varied duties, frequent change	
2 Repeated, set procedures	
3 Matching specified instructions	
4 Directing & planning for others	X
5 Working with others	X
6 Working alone & apart	
7 Influencing other people's ideas	X
8 Risks, unexpected events, emergencies	
9 Making empirical judgments, decisions	X
0 Analyzing facts and figures	
X Interpreting personal feelings	X
Y Precision, accuracy	

RELATION TO:

1 Data: Synthesizing	X
2 People: Persuading	X
3 Things: Precision Working	X

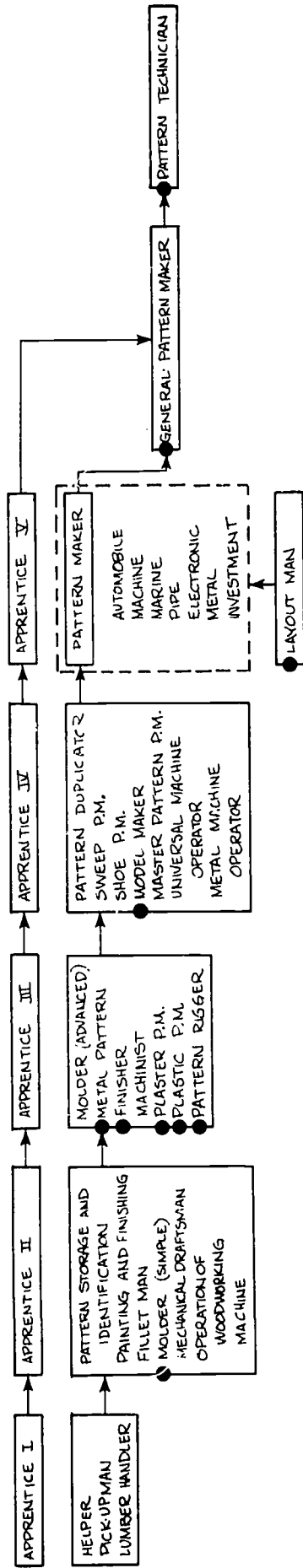

GENERAL WOODWORKING
PATTERNMAKING

● SELECTED JOBS

GENERAL WOODWORKING: PATTERNMAKING

The patternmaker is primarily engaged in the production, alteration, repair, and maintenance of patterns and core boxes. A pattern is a model of a product, part, or other object that is to be cast in metal. To make the casting mold, sand is rammed around a pattern mounted in a frame (flask); when removed, the pattern leaves a cavity into which molten metal is poured. Core boxes are used to make inserts which form interior cavities, or projections in a casting. Patterns may be made of wood, plaster, plastic, or metal; master patterns, which are used to make metal and plastic patterns, are usually wood.

The general patternmaker must be able to work with all patternmaking materials. Apprenticeship is the principal means of qualifying as a journeyman in this field, but vocational-technical training may be credited toward completion of the 5-year apprenticeship period. In some cases, on-the-job training may also be substituted for formal apprenticeship training.

A majority of patternmakers are employed in specially equipped foundry shops in plants which manufacture such products as machinery, transportation equipment, and fabricated metal products. Others work in independent foundries or in job shops that make patterns to order.

A highly skilled craftsman, the patternmaker usually earns more than other woodworkers or foundry workers. In addition, with his metalworking and woodworking skills, he can transfer to related jobs in other fields when foundry work is not available.

The MOLDER

prepares a sand mold by ramming sand around a pattern in a flask; when removed, the pattern leaves a cavity into which molten metal will be poured to make a casting. He may do hand, bench, floor, or machine molding.

RELATED JOBS:
sweep molder

LOWER LEVEL JOBS:
apprentice

PLACEMENT OPPORTUNITIES:
ferrous and nonferrous foundries
die casting
missile, spacecraft manufacturing
plumbing
electronics industry

EMPLOYMENT OUTLOOK:
slight rise

HOURS: 40/week

AVG. EARNINGS: \$1.75-3.00/hour

HIGH SCHOOL COURSE OF STUDY:	
1	Business Education
2	College Preparatory
3	Computer Data Processing
4	Electro Electronics
5	Food Preparation
6	General Piping
7	General Woodworking X
8	Graphic & Commercial Art
9	Health Occupations
0	Home Economics
X	Metals & Machines
Y	Power Mechanics

TOTAL EDUC/TRNG REQUIREMENTS:	
1	HS Grade Completed: 10 X
2	11
3	12
4	13 & 14
5	On-the-Job Training $\frac{1}{2}$ year
6	Apprentice Training
7	Post-HS Tech/Trade
8	Business College
9	Jr College (2 yr)
0	College Graduate
X	Graduate School

SPECIAL REQUIREMENTS:	
Minimum age:	18

CONDITIONS:	
1	Inside X
	Outside
	Both
2	Cold temp X
3	Hot temp
4	Wet, humid
5	Noise, vibration
6	Hazards* X
7	Fumes X
	Odors X
	Toxic
	Dust
	Poor ventilation
8	Other

* Burns; dropped heavy objects; power tools and machines

APTITUDES:	
1	Verbal
2	Numerical X
3	Abstract
4	Spatial X
	Clerical X
5	Mechanical X
7	Spelling
8	Grammar

PHYSICAL DEMANDS:	
1	Strength L,M
2	Climbing, balancing X
3	Stooping, kneeling, crawling X
4	Manual dexterity X
6	Talking, hearing X
7	Visual acuity X
	Standing for long time periods

INTERESTS:	
1	Dealing with things & objects X
2	Business contact with people
3	Routine, system
4	Social welfare
5	Prestige, esteem
6	Communication of ideas
7	Science & technology
8	Abstraction, creativity
9	Machines, procedures X
0	Tangible results X

TEMPERAMENT:	
1	Varied duties, frequent change
2	Repeated, set procedures
3	Matching specified instructions X
4	Directing & planning for others
5	Working with others
6	Working alone & apart
7	Influencing other people's ideas
8	Risks, unexpected events, emergencies
9	Making empirical judgments, decisions
0	Analyzing facts and figures
X	Interpreting personal feelings
Y	Precision, accuracy X

RELATION TO:	
1	Data: Compiling X
2	People:
3	Things: Precision Working X

performs all the finishing operations on a pattern: sanding, putting in fillets, stamping on identification numbers, and applying sealant and finish coating, including color-identifying the body, core prints, etc.

Pattern finishing is part of the apprenticeship training for patternmaking.

LOWER LEVEL JOBS:
apprentice, helper

PLACEMENT OPPORTUNITIES:
ferrous and nonferrous foundries
captive, job shops

EMPLOYMENT OUTLOOK: moderate

HOURS: 40/week

AVG. EARNINGS: \$2.25-5.50/hour

HIGH SCHOOL COURSE OF STUDY:

1 Business Education	
2 College Preparatory	
3 Computer Data Processing	
4 Electro Electronics	
5 Food Preparation	
6 General Piping	
7 General Woodworking	X
8 Graphic & Commercial Art	
9 Health Occupations	
0 Home Economics	
X Metals & Machines	
Y Power Mechanics	

TOTAL EDUC/TRNG REQUIREMENTS:

1 HS Grade Completed:	10
2	11 X
3	12
4	13 & 14
5 On-The-Job Training	0-3 year
6 Apprentices Training	
7 Post-HS Tech/Trade	
8 Business College	
9 Jr College (2 yr)	
0 College Graduate	
X Graduate School	

SPECIAL REQUIREMENTS:

Minimum age: 16

CONDITIONS:

1 Inside	X
2 Outside	
3 Both	
4 Cold temp	
5 Hot temp	
6 Wet, humid	
7 Noise, vibration	
8 Hazards	
9 Fumes	X
0 Odors	X
X Toxic	X
Y Dust	
Other	

APTITUDES:

1 Verbal	
2 Numerical	X
3 Abstract	
4 Spatial	X
5 Clerical	X
6 Mechanical	X
7 Spelling	
8 Grammar	

PHYSICAL DEMANDS:

1 Strength	L
2 Climbing, balancing	
3 Stooping, kneeling, crawling	
4 Manual dexterity	X
5 Talking, hearing	
6 Visual acuity	X
7 Other	
Standing for long time periods	

INTERESTS:

1 Dealing with things & objects	X
2 Business contact with people	
3 Routine, system	
4 Social welfare	
5 Prestige, esteem	
6 Communication of ideas	
7 Science & technology	
8 Abstraction, creativity	
9 Machines, procedures	X
0 Tangible results	X

TEMPERAMENT:

1 Varied duties, frequent change	
2 Repeated, set procedures	
3 Matching specified instructions	
4 Directing & planning for others	
5 Working with others	
6 Working alone & apart	
7 Influencing other people's ideas	
8 Risks, unexpected events, emergencies	
9 Making empirical judgments, decisions	
0 Analyzing facts and figures	X
X Interpreting personal feelings	
Y Precision, accuracy	X

RELATION TO:

1 Data: Analyzing	X
2 People:	
3 Things: Precision Working	X

(For purposes of trait analysis: Patternmaker, Apprentice)

The PATTERN RIGGER

constructs cope and drag boards, mounts patterns on boards, and inserts pins and plates. He also makes and fastens risers, runners, and gates, and applies finish coat.

Pattern rigging is part of the apprenticeship training for patternmaking.

LOWER LEVEL JOBS:
apprentice, helper

PLACEMENT OPPORTUNITIES:
ferrous and nonferrous foundries
plastics manufacturing

EMPLOYMENT OUTLOOK: moderate

HOURS: 40/week

AVG. EARNINGS: \$2.25-\$3.00/hour

HIGH SCHOOL COURSE OF STUDY:

1 Business Education	
2 College Preparatory	
3 Computer Data Processing	
4 Electro Electronics	
5 Food Preparation	
6 General Piping	
7 General Woodworking	X
8 Graphic & Commercial Art	
9 Health Occupations	
0 Home Economics	
X Metals & Machines	
Y Power Mechanics	

TOTAL EDUC/TRNG REQUIREMENTS:

1 HS Grade Completed:	10
2	11 X
3	12
4	13 & 14
5 On-The-Job Training	1-1 year
6 Apprenticeship Training	
7 Post-HS Tech/Trade	
8 Business College	
9 Jr College (2 yr)	
0 College Graduate	
X Graduate School	

SPECIAL REQUIREMENTS:

Minimum age: 18

(D.O.T.: Pattern Caster)

CONDITIONS:

1 Inside	X
2 Outside	
3 Both	
4 Cold temp	
5 Hot temp	
6 Wet, humid	
7 Noise, vibration	
8 Hazards *	X
9 Fumes	
0 Odors	
X Toxic	
Y Dust	X
Other	
* Cutting tools and machines	

APTITUDES:

1 Verbal	
2 Numerical	
3 Abstract	
4 Spatial	X
5 Clerical	X
6 Mechanical	X
7 Spelling	
8 Grammar	

PHYSICAL DEMANDS:

1 Strength	L,M
2 Climbing, balancing	
3 Stooping, kneeling, crawling	X
4 Manual dexterity	X
5 Talking, hearing	
6 Visual acuity	X
7 Other	
Standing for long time periods	

INTERESTS:

1 Dealing with things & objects	X
2 Business contact with people	
3 Routine, system	X
4 Social welfare	
5 Prestige, esteem	
6 Communication of ideas	
7 Science & technology	
8 Abstraction, creativity	
9 Machines, procedures	X
0 Tangible results	X

TEMPERAMENT:

1 Varied duties, frequent change	
2 Repeated, set procedures	X
3 Matching specified instructions	
4 Directing & planning for others	
5 Working with others	
6 Working alone & apart	
7 Influencing other people's ideas	
8 Risks, unexpected events, emergencies	
9 Making empirical judgments, decisions	
0 Analyzing facts and figures	
X Interpreting personal feelings	
Y Precision, accuracy	X

RELATION TO:

1 Data:	
2 People:	
3 Things: Manipulating	X

The METAL PATTERNMAKER

performs all machine operations on rough metal castings designed as metal patterns or core boxes: Milling, boring, drilling, grinding, and lathe turning. He checks results against blueprints with calipers, gages, etc. He may construct or fabricate sweeps to make symmetrical castings.

Apprenticeship training in general pattermaking includes working with metal.

RELATED JOBS:

- wood patternmaker
- plaster patternmaker
- plastics patternmaker
- pattern repairman

LOWER LEVEL JOBS:

- apprentice, helper
- molder
- pattern finisher
- pattern rigger
- model maker

PLACEMENT OPPORTUNITIES:

ferrous and nonferrous foundries
die casting and forging industries
missile, spacecraft manufacturing
electronics industry
automobile manufacturing
corporation and job shops
plastics manufacturing

EMPLOYMENT OUTLOOK: moderate

HOURS: 40/week

AVG. EARNINGS: \$2.25-5.50/hour

BEST AVAILABLE COPY

ABLE/GUIDANCE/FORM G-1

HIGH SCHOOL COURSE OF STUDY:

1 Business Education	
2 College Preparatory	
3 Computer Data Processing	
4 Electro Electronics	
5 Food Preparation	
6 General Piping	
7 General Woodworking	X
8 Graphic & Commercial Art	
9 Health Occupations	
0 Home Economics	
X Metals & Machines	
Y Power Mechanics	

TOTAL EDUC/TRNG REQUIREMENTS:

1 HS Grade Completed:	10
2	11 X
3	12
4	13 & 14
5 On-The-Job Training	3-5 years
6 Apprentices Training	
7 Post-HS Tech/Trade	
8 Business College	
9 Jr College (2 yr)	
0 College Graduate	
X Graduate School	

SPECIAL REQUIREMENTS:

Minimum age:	18
--------------	----

CONDITIONS:

1 Inside	X
Outside	
Both	
2 Cold temp	
3 Hot temp	
4 Wet, humid	
5 Noise, vibration	
6 Hazards*	X
7 Fumes	
8 Odors	
9 Toxic	
Dust	X
Poor ventilation	
0 Other	
*Cutting tools and machines	

APTITUDES:

1 Verbal	
2 Numerical	X
3 Abstract	
4 Spatial	X
5 Clerical	X
6 Mechanical	X
7 Spelling	
8 Grammar	

PHYSICAL DEMANDS:

1 Strength	L,M
2 Climbing, balancing	
3 Stooping, kneeling, crawling	
4 Manual dexterity	X
5 Talking, hearing	
6 Visual acuity	X
7 Other	
Standing for long time periods	

INTERESTS:

1 Dealing with things & objects	
2 Business contact with people	
3 Routine, system	
4 Social welfare	
5 Prestige, esteem	
6 Communication of ideas	
7 Science & technology	
8 Abstraction, creativity	
9 Machines, procedures	X
0 Tangible results	X

TEMPERAMENT:

1 Varied duties, frequent change	X
2 Repeated, set procedures	
3 Matching specified instructions	
4 Directing & planning for others	
5 Working with others	
6 Working alone & apart	
7 Influencing other people's ideas	
8 Risks, unexpected events, emergencies	
9 Making empirical judgments, decisions	
0 Analyzing facts and figures	X
X Interpreting personal feelings	
Y Precision, accuracy	X

RELATION TO:

1 Data: Analyzing	X
2 People:	
3 Things: Setting-up	X

THE PLASTER PATTERNMAKER

casts and finishes plaster patterns and core boxes used in making sand molds for dies, tools, and machine parts. He also makes plaster molds for checking patterns and core boxes.

Apprenticeship training in general patternmaking includes working with plaster.

RELATED JOBS:

- metal patternmaker
- plastics patternmaker
- wood patternmaker
- pattern repairman

LOWER LEVEL JOBS:

- apprentice, helper
- molder
- pattern finisher
- pattern rigger

PLACEMENT OPPORTUNITIES:

- ferrous and nonferrous foundries
- die casting and forging industries
- missile, spacecraft, and aircraft manufacturing
- electronics industry
- automobile manufacturing corporation and job shops
- plastics manufacturing

EMPLOYMENT OUTLOOK: moderate

HOURS: 40/week

AVG. EARNINGS: \$2.25-5.50/hour

BEST AVAILABLE COPY

ABLE/GUIDANCE/FORM G-1

HIGH SCHOOL COURSE OF STUDY:	
1 Business Education	
2 College Preparatory	
3 Computer Data Processing	
4 Electro Electronics	
5 Food Preparation	
6 General Piping	
7 General Woodworking	X
8 Graphic & Commercial Art	
9 Health Occupations	
0 Home Economics	
X Metals & Machines	
Y Power Mechanics	

TOTAL EDUC/TRNG REQUIREMENTS:	
1 HS Grade Completed:	10
2	11 X
3	12
4	13 & 14
5 On-the-Job Training	3-5 years
6 Apprentices Training	
7 Post-HS Tech/Trade	
8 Business College	
9 Jr College (2 yr)	
0 College Graduate	
X Graduate School	

SPECIAL REQUIREMENTS:	
Minimum age:	18

CONDITIONS:	
1 Inside	X
2 Outside	
3 Both	
4 Cold temp	
5 Hot temp	
6 Wet, humid	
7 Noise, vibration	
8 Hazards	
9 Fumes	
0 Odors	
X Toxic	
Dust	
Poor ventilation	
Other	X
Plaster is damp and messy to work with.	

APTITUDES:	
1 Verbal	
2 Numerical	X
3 Abstract	
4 Spatial	X
5 Clerical	X
6 Mechanical	X
7 Spelling	
8 Grammar	

PHYSICAL DEMANDS:	
1 Strength	L,M
2 Climbing, balancing	
3 Stooping, kneeling, crawling	
4 Manual dexterity	X
5 Talking, hearing	
6 Visual acuity	X
7 Other	
Standing for long time periods	

INTERESTS:	
1 Dealing with things & objects	X
2 Business contact with people	
3 Routine, system	
4 Social welfare	
5 Prestige, esteem	
6 Communication of ideas	
7 Science & technology	
8 Abstraction, creativity	
9 Machines, procedures	X
0 Tangible results	X

TEMPERAMENT:	
1 Varied duties, frequent change	
2 Repeated, set procedures	
3 Matching specified instructions	
4 Directing & planning for others	
5 Working with others	
6 Working alone & apart	
7 Influencing other people's ideas	
8 Risks, unexpected events, emergencies	
9 Making empirical judgments, decisions	
0 Analyzing facts and figures	X
X Interpreting personal feelings	
Y Precision, accuracy	X

RELATION TO:	
1 Data: Compiling	X
2 People:	
3 Things: Precision Working	X

PLASTICS PATTERNMAKER

makes and finishes patterns and core boxes of synthetic plastics, starting with wood patterns and plaster molds. He also fastens the finished patterns on production plates.

Apprenticeship training in general patternmaking includes working with plastics.

RELATED JOBS:

- metal patternmaker
- plaster patternmaker
- wood patternmaker
- pattern repairman

LOWER LEVEL JOBS:

- apprentice, helper
- pattern rigger
- pattern finisher
- molder

PLACEMENT OPPORTUNITIES:

- plastics manufacturing
- ferrous and nonferrous foundries
- die casting and forging industries
- missile, spacecraft manufacturing
- electronics industry
- automobile manufacturing
- corporation and job shops

EMPLOYMENT OUTLOOK: moderate

HOURS: 40/week

AVG. EARNINGS: \$2.25-5.50/hour

HIGH SCHOOL COURSE OF STUDY:

1 Business Education	
2 College Preparatory	
3 Computer Data Processing	
4 Electro Electronics	
5 Food Preparation	
6 General Piping	
7 General Woodworking	X
8 Graphic & Commercial Art	
9 Health Occupations	
0 Home Economics	
X Metals & Machines	
Y Power Mechanics	

TOTAL EDUC/TRNG REQUIREMENTS:

1 HS Grade Completed:	10
2	11 X
3	12
4	13 & 14
5 On-The-Job Training	3-5 years
6 Apprentice Training	
7 Post-HS Tech/Trade	
8 Business College	
9 Jr College (2 yr)	
0 College Graduate	
X Graduate School	

SPECIAL REQUIREMENTS:

Minimum age:	i8
--------------	----

CONDITIONS:

1 Inside	X
Outside	
Both	
2 Cold temp	
3 Hot temp	
4 Wet, humid	
5 Noise, vibration	
6 Hazards *	X
7 Fumes	
Odors	
Toxic	X
Dust	
Poor ventilation	
9 Other	
Power tools and machines	

TALENTS:

1 Verbal	
2 Numerical	X
3 Abstract	
4 Spatial	X
5 Clerical	X
6 Mechanical	X
7 Spelling	
8 Grammar	

PHYSICAL DEMANDS:

1 Strength	L, M
2 Climbing, balancing	
3 Stooping, kneeling, crawling	X
4 Manual dexterity	X
5 Talking, hearing	
6 Visual acuity	X
7 Other Standing for long periods	

INTERESTS:

1 Dealing with things & objects	X
2 Business contact with people	
3 Routine, system	
4 Social welfare	
5 Prestige, esteem	
6 Communication of ideas	
7 Science & technology	
8 Abstraction, creativity	
9 Machines, procedures	X
0 Tangible results	X

TEMPERAMENT:

1 Varied duties, frequent change	
2 Repeated, set procedures	
3 Matching specified instructions	
4 Directing & planning for others	
5 Working with others	
6 Working alone & apart	
7 Influencing other people's ideas	
8 Risks, unexpected events, emergencies	
9 Making empirical judgments, decisions	
0 Analyzing facts and figures	X
X Interpreting personal feelings	
Y Precision, accuracy	X

RELATION TO:

1 Data: Compiling	X
2 People:	
3 Things: Precision Working	X

The MODEL MAKER

working from blueprints, constructs wood, plaster, plastic, or metal models to scale or full size. He uses metalworking and woodworking machines and tools and precision instruments. These models may be used for testing, display, or as models for making molds for casting.

Apprenticeship training in general patternmaking includes model making.

LOWER LEVEL JOBS:
apprentice, helper

PLACEMENT OPPORTUNITIES:

model shops
ferrous and nonferrous foundries
furniture shops
captive, job shops
marine equipment manufacturing
electronics industry
architecture and building construction
aircraft, missile, and spacecraft manufacturing

EMPLOYMENT OUTLOOK: moderate

HOURS: 40/week

AVG. EARNINGS: \$2.25-4.50/hour

HIGH SCHOOL COURSE OF STUDY:	
1 Business Education	
2 College Preparatory	
3 Computer Data Processing	
4 Electro electronics	
5 Food Preparation	
6 General Piping	
7 General Woodworking	X
8 Graphic & Commercial Art	
9 Health Occupations	
0 Home Economics	
X Metals & Machines	
Y Power Mechanics	

TOTAL EDUC/TRNG REQUIREMENTS:	
1 HS Grade Completed:	10
2	11
3	12 X
4	13 & 14
5 On-The-Job Training	2-4 years
6 Apprentices Training	
7 Post-HS Tech/Trade	
8 Business College	
9 Jr College (2 yr)	
0 College Graduate	
X Graduate School	

SPECIAL REQUIREMENTS:	
Minimum age:	18

CONDITIONS:	
1 Inside	X
Outside	
Both	
2 Cold temp	
3 Hot temp	
4 Wet, humid	
5 Noise, vibration	
6 Hazards *	X
7 Fumes	
Odors	X
Toxic	X
Dust	X
Poor ventilation	
8 Other	
*Cutting machinery; flying particles	

APTITUDES:	
1 Verbal	
2 Numerical	X
3 Abstract	
4 Spatial	X
5 Clerical	X
6 Mechanical	X
7 Spelling	
8 Grammar	

PHYSICAL DEMANDS:	
1 Strength	L-H
2 Climbing, balancing	
3 Stooping, kneeling, crawling	
4 Manual dexterity	X
5 Talking, hearing	
6 Visual acuity	X
7 Other	
Standing long time periods	

INTERESTS:	
1 Dealing with things & objects	
2 Business contact with people	
3 Routine, system	
4 Social welfare	
5 Prestige, esteem	
6 Communication of ideas	
7 Science & technology	
8 Abstraction, creativity	
9 Machines, procedures	X
0 Tangible results	X

TEMPERAMENT:	
1 Varied duties, frequent change	X
2 Repeated, set procedures	
3 Matching specified instructions	
4 Directing & planning for others	
5 Working with others	
6 Working alone & apart	
7 Influencing other people's ideas	
8 Risks, unexpected events, emergencies	
9 Making empirical judgments, decisions	
0 Analyzing facts and figures	X
X Interpreting personal feelings	
Y Precision, accuracy	X

RELATION TO:	
1 Data: Compiling	X
2 People:	
3 Things: Setting-up	X

The pattern LAYOUT MAN

makes scale drawings of one or more views of a pattern or core box. The layout enables the pattermaker to make a pattern to precise dimensions, allowing for draft, cores, finish, shrinkage, and other construction and molding features. The layout man, who is usually the shop foreman, instructs and supervises pattermakers and checks the finished pattern before it is shipped out.

LOWER LEVEL JOBS:

- pattermakers
- bench hand
- apprentice, helper
- molder

PLACEMENT OPPORTUNITIES:

- ferrous and nonferrous foundries
- die casting and forging industries
- missile, spacecraft manufacturing
- electronics industry
- automobile manufacturing
- corporation and job shops

EMPLOYMENT OUTLOOK: moderate

HOURS: 40/week

AVG. EARNINGS: \$4.00-6.00/hour

HIGH SCHOOL COURSE OF STUDY:

1 Business Education	
2 College Preparatory	
3 Computer Data Processing	
4 Electro Electronics	
5 Food Preparation	
6 General Piping	
7 General Woodworking	X
8 Graphic & Commercial Art	
9 Health Occupations	
0 Home Economics	
X Metals & Mechanics	
Y Power Mechanics	

TOTAL EDUC/TRNG REQUIREMENTS:

1 HS Grade Completed:	10
2	11
3	12
4	13 & 14
5 On-The-Job Training	3-5 years
6 Apprentive Training	
7 Post-HS Tech/Trade	
8 Business College	
9 Jr College (2 yr)	
0 College Graduate	
X Graduate School	

SPECIAL REQUIREMENTS:

Minimum age: 16

CONDITIONS:

1 Inside	X
Outside	
Both	
2 Cold temp	
3 Hot temp	
4 Wet, humid	
5 Noise, vibration	
6 Hazards *	X
7 Fumes	
Odors	
Toxic	
Dust	
Poor ventilation	
8 Other	

* Cutting tools and machines

APTITUDES:

1 Verbal	
2 Numerical	X
3 Abstract	X
4 Spatial	X
5 Clerical	X
6 Mechanical	X
7 Spelling	
8 Grammar	

PHYSICAL DEMANDS:

1 Strength	L
2 Climbing, balancing	
3 Stooping, kneeling, crawling	
4 Manual dexterity	X
5 Talking, hearing	
6 Visual acuity	X
7 Other	
Standing for long time periods	

INTERESTS:

1 Dealing with things & objects	X
2 Business contact with people	
3 Routine, system	
4 Social welfare	
5 Prestige, esteem	
6 Communication of ideas	
7 Science & technology	
8 Abstraction, creativity	
9 Machines, procedures	X
0 Tangible results	X

TEMPERAMENT:

1 Varied duties, frequent change	
2 Repeated, set procedures	
3 Matching specified instructions	
4 Directing & planning for others	X
5 Working with others	
6 Working alone & apart	
7 Influencing other people's ideas	
8 Risks, unexpected events, emergencies	
9 Making empirical judgments, decisions	
0 Analyzing facts and figures	X
X Interpreting personal feelings	
Y Precision, accuracy	X

RELATION TO:

1 Data: Compiling	X
2 People:	
3 Things: Precision Work	X

THE GENERAL PATTERNMAKER

(also ALL-ROUND PATTERNMAKER) works from blueprints to construct, repair, alter, and maintain wood, metal, plaster, and plastic patterns and core boxes. Using various tools and machines, he selects and lays out the appropriate stock, cuts and shapes the parts, assembles and finishes the pattern. He may estimate costs and advise customer on design and other factors.

LOWER LEVEL JOBS:

- apprentice, helper molder
- pattern finisher
- pattern rigger
- specialized patternmakers

PLACEMENT OPPORTUNITIES:

- ferrous and nonferrous foundries
- die casting and forging industries
- missile, spacecraft manufacturing
- electronics industry
- automobile manufacturing
- corporation and job shops
- plastics manufacturing

EMPLOYMENT OUTLOOK: moderate

HOURS: 40/week

AVG. EARNINGS: \$2.25-5.50/hour

HIGH SCHOOL COURSE OF STUDY:	
1	Business Education
2	College Preparatory
3	Computer Data Processing
4	Electronics
5	Food Preparation
6	General Planning
7	General Woodworking X
8	Graphic & Commercial Art
9	Health Occupations
0	Home Economics
X	Metals & Machines
Y	Power Mechanics

TOTAL EDUC/TRNG REQUIREMENTS:

1	HS Grade Completed: 10
2	11
3	12 X
4	13 & 14
5	On-The-Job Training 5 years
6	Apprentice Training
7	Post-HS Tech/Trade
8	Business College
9	Jr College (2 yr)
0	College Graduate
X	Graduate School

SPECIAL REQUIREMENTS:

Minimum age: 18

CONDITIONS:	
1	Inside X
	Outside
	Both
2	Cold temp
3	Hot temp
4	Wet, humid
5	Noise, vibration
6	Hazards * X
7	Fumes X
	Odors X
	Toxic X
	Dust X
	Poor ventilation
8	Other
	Cutting tools and machines

APTITUDES:

1	Verbal
2	Numerical X
3	Abstract X
4	Spatial X
5	Clerical X
6	Mechanical X
7	Spelling
8	Grammar

PHYSICAL DEMANDS:

1	Strength L-H
2	Climbing, balancing
3	Stooping, kneeling, crawling
4	Manual dexterity X
5	Talking, hearing
6	Visual acuity X
7	Other
	Standing for long time periods

INTERESTS:	
1	Dealing with things & objects
2	Business contact with people
3	Routine, system
4	Social welfare
5	Prestige, esteem
6	Communication of ideas
7	Science & technology
8	Abstraction, creativity
9	Machines, procedures X
0	Tangible results X

TEMPERAMENT:

1	Varied duties, frequent change X
2	Repeated, set procedures
3	Matching specified instructions
4	Directing & planning for others
5	Working with others
6	Working alone & apart
7	Influencing other people's ideas
8	Risks, unexpected events, emergencies
9	Making empirical judgments, decisions
0	Analyzing facts and figures X
X	Interpreting personal feelings
Y	Precision, accuracy X

RELATION TO:

1	Data: Analyzing X
2	People:
3	Things: Setting-up X

The PATTERN TECHNICIAN

works with engineers or machine designers and the foundry staff in determining appropriate parts and equipment for molding and pattern construction. He also solves problems which may arise concerning pattern-making and foundry work. He estimates costs, schedules delivery, and checks patterns for accuracy and workmanship. He must be familiar with machine design as well as all kinds of pattermaking, foundry practices and techniques.

LOWER LEVEL JOBS:

- wood patternmaker
- metal patternmaker
- plaster patternmaker
- plastics patternmaker
- tool and die maker
- molder

PLACEMENT OPPORTUNITIES:

- ferrous and nonferrous foundries
- pattern job shops
- machine design industries
- governmental agencies

EMPLOYMENT OUTLOOK: moderate

HOURS: 40/week

AVG. EARNINGS: \$4.00-6.00/hour

HIGH SCHOOL COURSE OF STUDY:

1 Business Education	
2 College Preparatory	
3 Computer Data Processing	
4 Electro Electronics	
5 Food Preparation	
6 General Piping	
7 General Woodworking	X
8 Graphic & Commercial Art	
9 Health Occupations	
0 Home Economics	
X Metals & Machines	
Y Power Mechanics	

TOTAL EDUC/TRNG REQUIREMENTS:

1 HS Grade Completed:	10
2	11
3	12
4	13 & 14
5 On-The-Job Training	6 years
6 Apprentices Training	
7 Post-HS Tech/Trade	
8 Business College	
9 Jr College (2 yr)	
0 College Graduate	
X Graduate School	

SPECIAL REQUIREMENTS:

Minimum age:	18
--------------	----

CONDITIONS:

1 Inside	X
Outside	
Both	
2 Cold temp	
3 Hot temp	
4 Wet, humid	
5 Noise, vibration	
6 Hazards*	X
7 Fumes	
Odors	
Toxic	
Dust	
Poor ventilation	
8 Other	

*Power tools and machines

APTITUDES:

1 Verbal	X
2 Numerical	X
3 Abstract	X
4 Spatial	X
5 Clerical	X
6 Mechanical	X
7 Spelling	
8 Grammar	X

PHYSICAL DEMANDS:

1 Strength	
2 Climbing, balancing, kneeling, crawling	
3 Stooping, kneeling, crawling	
4 Manual dexterity	X
5 Talking, hearing	
6 Visual acuity	X
7 Other	

INTERESTS:

1 Dealing with things & objects	
2 Business contact with people	
3 Routine, system	
4 Social welfare	
5 Prestige, esteem	
6 Communication of ideas	
7 Science & technology	X
8 Abstraction, creativity	X
9 Machines, procedures	X
0 Tangible results	

TEMPERAMENT:

1 Varied duties, frequent change	
2 Repeated, set procedures	
3 Matching specified instructions	
4 Directing & planning for others	X
5 Working with others	
6 Working alone & apart	
7 Influencing other people's ideas	
8 Risks, unexpected events, emergencies	
9 Making empirical judgments, decisions	
0 Analyzing facts and figures	X
X Interpreting personal feelings	
Y Precision, accuracy	X

RELATION TO:

1 Data: Synthesizing	X
2 People:	
3 Things: Precision Working	X

**For purposes of trait analysis: Pattern Engineer

For ease of reference, the following material is excerpted from Appendix A and Appendix B of Volume II of the 1965 Dictionary of Occupational Titles:

RELATION TO DATA, PEOPLE, AND THINGS

. . . The last three digits of the occupational code number of a job express the job's relationship to Data, People, and Things. Only those relationships which are significant in terms of the requirements of the job are reflected in the code numbers. The incidental relationships which every worker has to Data, People, and Things--but which do not seriously affect successful performance of the essential duties of the job--are not reflected. Each successive relationship includes those that are simpler . . .

DATA (4th digit)	PEOPLE (5th digit)	THINGS (6th digit)
0 Synthesizing	0 Mentoring	0 Setting-Up
1 Coordinating	1 Negotiating	1 Precision Working
2 Analyzing	2 Instructing	2 Operating-Controlling
3 Compiling	3 Supervising	3 Driving-Operating
4 Computing	4 Diverting	4 Manipulating
5 Copying	5 Persuading	5 Tending
6 Comparing	6 Speaking-Signaling	6 Feeding-Offbearing
7 } No significant relationship	7 Serving	7 Handling
8 }	8 No significant relationship	8 No significant relationship

INTERESTS

Preferences for certain types of work activities or experiences, with accompanying rejection of contrary types of activities or experiences. Five pairs of interest factors are provided so that a positive preference for one factor of a pair also implies rejection of the other factor of that pair.

- 1 Situations involving a preference for activities dealing with things and objects. vs. 6 Situations involving a preference for activities concerned with people and the communication of ideas.
- 2 Situations involving a preference for activities involving business contact with people. vs. 7 Situations involving a preference for activities of a scientific and technical nature.
- 3 Situations involving a preference for activities of a routine, concrete, organized nature. vs. 8 Situations involving a preference for activities of an abstract and creative nature.
- 4 Situations involving a preference for working for people for their presumed good, as in the social welfare sense, or for dealing with people and language in social situations. vs. 9 Situations involving a preference for activities that are nonsocial in nature, and are carried on in relation to processes, machines, and techniques.
- 5 Situations involving a preference for activities resulting in prestige or the esteem of others. vs. 0 Situations involving a preference for activities resulting in tangible, productive satisfaction.

WORKING CONDITIONS

Working conditions are the physical surroundings of a worker in a specific job.

- 1 Inside, Outside, or Both:
 - 1 Inside: Protection from weather conditions but not necessarily from temperature changes.
 - 0 Outside: No effective protection from weather.
 - B Both: Inside and outside.

A job is considered "inside" if the worker spends approximately 75 per cent or more of his time inside, and "outside" if he spends approximately 75 per cent or more of his time outside. A job is considered "both" if the activities occur inside or outside in approximately equal amounts.
- 2 Extremes of Cold Plus Temperature Changes:
 - (1) Extremes of Cold: Temperature sufficiently low to cause marked bodily discomfort unless the worker is provided with exceptional protection.
 - (2) Temperature Changes: Variations in temperature which are sufficiently marked and abrupt to cause noticeable bodily reactions.
- 3 Extremes of Heat Plus Temperature Changes:
 - (1) Extremes of Heat: Temperature sufficiently high to cause marked bodily discomfort unless the worker is provided with exceptional protection.
 - (2) Temperature Changes: Same as 2(2).
- 4 Wet and Humid:
 - (1) Wet: Contact with water or other liquids.
 - (2) Humid: Atmospheric condition with moisture content sufficiently high to cause marked bodily discomfort.
- 5 Noise and Vibration:

Sufficient noise, either constant or intermittent, to cause marked distraction or possible injury to the sense of hearing and/or sufficient vibration (production of an oscillating movement or strain on the body or its extremities from repeated motion or shock) to cause bodily harm if endured day after day.
- 6 Hazards:

Situations in which the individual is exposed to the definite risk of bodily injury.

7 Fumes, Odors, Toxic Conditions, Dust, and Poor Ventilation:

- (1) Fumes: Smoky or vaporous exhalations, usually odorless, thrown off as the result of combustion or chemical reaction.
- (2) Odors: Noxious smells, either toxic or nontoxic.
- (3) Toxic Conditions: Exposure to toxic dust, fumes, gases, vapors, mists, or liquids which cause general or localized disabling conditions as a result of inhalation or action on the skin.
- (4) Dust: Air filled with small particles of any kind, such as textile dust, flour, wood, leather, feathers, etc., and inorganic dust, including silica and asbestos, which make the workplace unpleasant or are the source of occupational diseases.
- (5) Poor Ventilation: Insufficient movement of air causing a feeling of suffocation; or exposure to drafts.

TEMPERAMENTS

Different types of occupational situations to which workers must adjust.

- 1 Situations involving a variety of duties often characterized by frequent change.
- 2 Situations involving repetitive or short cycle operations carried out according to set procedures or sequences.
- 3 Situations involving doing things only under specific instruction, allowing little or no room for independent action or judgment in working out job problems.
- 4 Situations involving the direction, control, and planning of an entire activity or the activities of others.
- 5 Situations involving the necessity of dealing with people in actual job duties beyond giving and receiving instructions.
- 6 Situations involving working alone and apart in physical isolation from others, although the activity may be integrated with that of others.
- 7 Situations involving influencing people in their opinions, attitudes, or judgments about ideas or things.
- 8 Situations involving performing adequately under stress when confronted with the critical or unexpected or when taking risks.
- 9 Situations involving the evaluation (arriving at generalizations, judgments, or decisions) of information against sensory or judgmental criteria.
- 0 Situations involving the evaluation (arriving at generalizations, judgments, or decisions) of information against measurable or verifiable criteria.
- X Situations involving the interpretation of feelings, ideas, or facts in terms of personal viewpoint.
- Y Situations involving the precise attainment of set limits, tolerances, or standards.

PHYSICAL DEMANDS

Physical demands are those physical activities required of a worker in a job.

The physical demands referred to in this Dictionary serve as a means of expressing both the physical requirements of the job and the physical capacities (specific physical traits) a worker must have to meet the requirements. For example, "seeing" is the name of a physical demand required by many jobs (perceiving by the sense of vision), and also the name of a specific capacity possessed by many people (having the power of sight). The worker must possess physical capacities at least in an amount equal to the physical demands made by the job.

The Factors

- 1 Lifting, Carrying, Pushing, and/or Pulling (Strength). These are the primary "strength" physical requirements, and generally speaking, a person who engages in one of these activities can engage in all. Specifically, each of these activities can be described as:
 - (1) Lifting: Raising or lowering an object from one level to another (includes upward pulling).
 - (2) Carrying: Transporting an object, usually holding it in the hands or arms or on the shoulder.
 - (3) Pushing: Exerting force upon an object so that the object moves away from the force (includes slapping, striking, kicking, and treadle actions).
 - (4) Pulling: Exerting force upon an object so that the object moves toward the force (includes jerking).

The five degrees of Physical Demands Factor No. 1 (Lifting, Carrying, Pushing, and/or Pulling), are as follows:

S Sedentary Work

Lifting 10 lbs. maximum and occasionally lifting and/or carrying such articles as dockets, ledgers, and small tools. Although a sedentary job is defined as one which involves sitting, a certain amount of walking and standing is often necessary in carrying out job duties. Jobs are sedentary if walking and standing are required only occasionally and other sedentary criteria are met.

L Light Work

Lifting 20 lbs. maximum with frequent lifting and/or carrying of objects weighting up to 10 lbs. Even though the weight lifted may be only a negligible amount, a job is in this category when it requires walking or standing to a significant degree, or when it involves sitting most of the time with a degree of pushing and pulling of arm and/or leg controls.

M Medium Work

Lifting 50 lbs. maximum with frequent lifting and/or carrying of objects weighing up to 25 lbs.

H Heavy Work

Lifting 100 lbs. maximum with frequent lifting and/or carrying of objects weighing up to 50 lbs.

V Very Heavy Work

Lifting objects in excess of 100 lbs. with frequent lifting and/or carrying of objects weighing 50 lbs. or more.

2 Climbing and/or Balancing:

- (1) Climbing: Ascending or descending ladders, stairs, scaffolding, ramps, poles, ropes, and the like, using the feet and legs and/or hands and arms.
- (2) Balancing: Maintaining body equilibrium to prevent falling when walking, standing, crouching, or running on narrow, slippery, or eratically moving surfaces; or maintaining body equilibrium when performing gymnastic feats.

3 Stooping, Kneeling, Crouching, and/or Crawling:

- (1) Stooping: Bending the body downward and forward by bending the spine at the waist.
- (2) Kneeling: Bending the legs at the knees to come to rest on the knee or knees.
- (3) Crouching: Bending the body downward and forward by bending the legs and spine.
- (4) Crawling: Moving about on the hands and knees or hands and feet.

4 Reaching, Handling, Fingering, and/or Feeling:

- (1) Reaching: Extending the hands and arms in any direction.
- (2) Handling: Seizing, holding, grasping, turning, or otherwise working with the hand or hands (fingering not involved).
- (3) Fingering: Picking, pinching, or otherwise working with the fingers primarily (rather than with the whole hand or arm as in handling).
- (4) Feeling: Perceiving such attributes of objects and materials as size, shape, temperature, or texture, by means of receptors in the skin, particularly those of the finger tips.

5 Talking and/or Hearing:

- (1) Talking: Expressing or exchanging ideas by means of the spoken word.
- (2) Hearing: Perceiving the nature of sounds by the ear.

6 Seeing:

Obtaining impressions through the eyes of the shape, size distance, motion, color, or other characteristics of objects. The major visual functions are: (1) acuity, far and near, (2) depth perception, (3) field of vision, (4) accommodation, (5) color vision. The functions are defined as follows:

- (1) Acuity, far--clarity of vision at 20 feet or more.
Acuity, near--clarity of vision at 20 inches or less.
- (2) Depth perception--three dimensional vision. The ability to judge distance and space relationships so as to see objects where and as they actually are.
- (3) Field of vision--the area that can be seen up and down or to the right or left while the eyes are fixed on a given point.
- (4) Accommodation--adjustment of the lens of the eye to bring an object into sharp focus. This item is especially important when doing near-point work at varying distances from the eye.
- (5) Color vision--the ability to identify and distinguish colors.

BIBLIOGRAPHY

Bureau of Business Research. Manpower skills survey. Chestnut Hill, Massachusetts: Boston College Press, 1964.

U. S. Department of Labor. Dictionary of occupational titles, Volumes I and II. Washington: U. S. Government Printing Office, March 1965.

U. S. Department of Labor. Occupational outlook handbook. Washington: U. S. Government Printing Office, 1966-1967.

APPENDIX C

Performance Objectives
By Job Family Clusters:
General Carpentry
Mill Carpentry
Patternmaking

GENERAL CARPENTRY

Construction Technician 160.131

Task 1. Estimates the amount of materials necessary to complete a job.

C.0. 1 Given blueprints and specifications and pencil and paper, the student will compute the amount of materials needed for a given job to the nearest \$100.

Task 2. Compiles a schedule of materials.

C.0. 1 Given blueprints and specifications and pencil and paper, the student will compile a schedule of materials, itemizing each type (2 x 4's, concrete, sheeting, finish, etc.).

Task 3. Arranges time schedule.

C.0. 1 Given a job, the student will compute work, tools, equipment, delivery and completion schedules resulting in minimum loss of time.

 Task 4. Identifies construction work progress.

C.0. 1 Given a time schedule, the student will identify work progress in all phases of construction.

Task 5. Computes strength and stress of material.

C.0. 1 Given blueprints, a chart listing strengths of materials and pencil and paper, the student will compute the stresses at various points and identify the appropriate materials needed for these points.

Task 6. Performs soil test.

C.0. 1 Given a construction site, test bar, soil test equipment, and pencil and paper, the student will identify the type of soil and its characteristics.

Task 7. Computes construction costs.

C.0. 1 Given the bill of materials, time records, pencil and paper, the student will compute the cost of the construction (profit or loss statement).

Cribber 860.884

Task 1. Reviews blueprint.

C.0. 1 Given the foundation plans for a house, identify the following dimensions from the blueprint: foundation length, width, and height, foundation openings, wall thickness and direction of the house.

C.0. 2 Verify the blueprint dimensions with supervisor, including location and heights of apertures, windows, openings for carrying beams and foundation heights.

Task 2. Supervises leveling of area.

C.0. 1 Given an excavated area, the student prepares and supervises the ground for erection of forms by leveling the ground to within one inch.

Task 3. Prepares forms.

- C.0. 1 Given a number of primary wall boards and 2 x 4 studs higher than foundation, the student erects first course forms by placing studs at the joints of the boards and approximately 8 to 10 feet apart.
- C.0. 2 Student erects second course and subsequent course forms by adding forms boards as required by height of foundation and a second set of studs so that no more than three boards are jointed in the same place.
- C.0. 3 Given prefabricated forms of panels, the student erects form by computing the number of forms required and attaching them to meet the required wall length, placing them approximately every 4 or 5 panels.

Task 4. Straightens and plumbs wall.

- C.0. 1 Given wall, the student attaches clamp-stringers, tie rods, and braces to the forms approximately one foot from the top and one foot from the bottom.
- C.0. 2 Given straight edge and spirit level and necessary basing, the student plumbs the wall by moving the wall until it's perpendicular and braced.

Task 5. Inserts boxes for openings.

- C.0. 1 Given location and dimensions (length by width by wall thickness) of opening, the student tacks nail boxes of given dimensions to wall form to 1/2 inch.

Floor Layer 864.781

Task 1. Identifies the type and amount of flooring materials necessary.

C.0. 1 Given a floor plan and specifications, the student will identify the type of flooring materials required and compute the amount needed to the nearest board foot.

Task 2. Installs floor finish.

C.0. 1 Given the type and amount of flooring material, saw, hammer, hand plane, square, and flooring nails, the student will cut and position the first course of flooring material parallel to the longer baseboard and fasten it in place.

C.0. 2 Given installed floor (with the exception of last course), scribe, coping saw, block plane, hammer and nails, the student will scribe the last course floor material to the contour of the wall, cut it, and fit and fasten the material in place.

Task 3. Installs flooring around irregular finish.

C.0. 1 Given flooring materials, scribe, hand plane, coping saw, hammer and nails, the student will scribe the flooring material to contour of finish, cut it, and fit and fasten the material in place so that all joints are tight (hairline).

Task 4. Sands floor.

C.0. 1 Given an installed floor, power sanders, sandpaper, scrapers, and sandpaper blocks, the student will sand the floor surface to an even, smooth finish.

Task 5. Applies coating material to floor.

C.0. 1 Given a sanded floor surface, coating material, brushes or rollers, power sanders and sandpaper, the student will apply two coats of floorsealer to the floor, (sanding down between coats).

Inside Finishman 860.381

Task 1. Reviews blueprint.

C.0. 1 Given a blueprint including the finish details, the student will identify the type of finish required.

Task 2. Joins finish using the miter method.

C.0. 1 Given a length of finish material, a room of a house ready for finish, miter box and saw, the student will miter the ends of the finish material as determined by room size and blueprint specifications.

C.0. 2 Given a mitered length of finish material, miter box and saw, the student will miter the material (width) to a fit which will result in a hairline joint.

Task 3. Joins finish using the coping method.

C.0. 1 Given a length of finish material, a room of a house ready for finish, measuring stick, jig saw, miter box, hammer, and nails, the student will cut the proper miter and undercut the end to the contour of the molding and fasten in place to form a hairline joint at the intersection.

Task 4. Reviews the blueprint for detail for doors.

C.O. 1 Given a blueprint showing finish details for doors, the student will identify the type and joinery of finish required.

Task 5. Constructs door jambs.

C.O. 1 See Task 7, C.O. 1, Finishman (outside).

Task 6. Fits finish around door jamb.

C.O. 1 Given an installed door and door jamb, required door trim (finish), saw, six-foot rule, miter box, hammer and nails, the student will measure, cut, and fit the trim and fasten it to the door jamb and wall in a way that hairline joints will result.

Task 7. Reviews blueprint which includes detail of standing finish (base trim).

C.O. 1 Given a blueprint which includes detail of standing finish (base trim), the student will identify the type and joinery of material required.

Task 8. Fits and fastens baseboard to both sides of room.

C.O. 1 Given the type and joinery of finish required, measuring stick, scribing tool, saw, hammer, and finish nails (8d), the student will measure the length of the room with a measuring stick, transfer the length to the finish stock, cut the stock, and fit and fasten it in place to the nearest 1/16 inch.

C.0. 2 Given baseboard trim fastened on both lengths of the room, measuring stick, finish saw, scribe, hammer, and finish nails, the student will measure the required length and scribe to contour, cut the trim, and fasten in place so that a hairline joint will result.

Task 9. Fits windows.

C.0. 1 See Task 16, C.0. 1 and 2, Finishman (outside).

Task 10. Inserts weights and parting strings in windows.

C.0. 1 Given a fitted window, weights, rope, parting stop, and knife, the student will tie the rope to the weight, insert the weight in the window, cut the rope to required length, tie a knot at the end of the rope, and insert the rope in the recess on the edge of the window so that when the window is open, the weight will be two to three inches from the window sill.

C.0. 2 Given installed upper sash, stop bead, ruler, block plane, saw, hammer, 4d finish nails, and nailset, the student will measure and cut the stop bead to length, and fit and fasten the stop bead in place.

Task 11. Fits aprons and trim and stools around windows.

C.0. 1 Given a fitted window, trim, stool, and apron stock, hammer, nails, saw, six-foot rule, square, scribe, and nailset, the student will measure and scribe the required dimensions, cut the stock to size and fasten it in position so that hairline joints will result.

Task 12. Installs window hardware.

C.O. 1 Given an installed window, required hardware, push drill, screwdriver and a six-foot rule, the student will locate positions of hardware, drill necessary pilot holes, and fasten the hardware to the window with screws.

Task 13. Reviews blueprint which includes detail of stairs.

C.O. 1 Given a blueprint which includes detail of stairs, the student will identify the type and jointery of materials required.

Task 14. Computes the run and rise.

C.O. 1 See Task 18, C.O. 1 and 2, Finishman (outside).

Task 15. Computes the platforms and wind if required.

C.O. 1 Given a blueprint which includes platforms and wind, the student will compute the amount of materials and the type of construction required.

Task 16. Lays out stringers.

C.O. 1 See Task 18, C.O. 2, Finishman (outside).

Task 17. Cuts out stringers.

C.O. 1 See Task 19, C.O. 1, Finishman (outside).

Task 18. Lays out rabbet on skirtboard or stringer.

C.O. 1 Given the dimensions, square, finish stock for rise and tread, pencil, six-foot rule, knife, the student will lay out the rabbet to size.

Task 19. Cuts rabbet.

C.0. 1 Given stringer with rabbet layed out, hand or power router, hammer and chisel, the student will cut out the rabbet to an even depth and straight edges on the face so that a hairline joint will appear between the riser and the tread.

Task 20. Fits risers.

C.0. 1 Given rabbeted skirtboards or stringers, tread and riser stock, hammer, nails and nailset, the student will fit the riser and tread material into the rabbeted stringers or skirtboards and fasten into place with finish nails so that there will be hairline joints between the rabbets and the treads and risers.

Task 21. Fastens finish molding to risers.

C.0. 1 See Task 2, C.0. 1 and 2 and Task 3, C.0. 1.

C.0. 2 Given a stairway with riser facing attached, railing material, balusters, saw, hammer, nails, and six-foot rule, the student will erect the posts, rails, or balusters as specified in the blueprint.

Task 22. Nails treads in place.

C.0. 1 Given erected stringers and required trimmings (rails, balusters, etc.), tread material, saw, hammer, and nails, the student will fasten treads to specifications listed in the blueprint.

Task 23. Newel posts, balusters, and handrails.

C.O. 1 Given erected stairs, newel post, baluster, and handrail materials, spirit level, saw, bit brace, dividers, six-foot rule, hammer, nails or screwdriver and screws, the student will cut, fit, and attach the materials to specifications in a blueprint.

Outside Finishman 860.381

Task 1. Reviews blueprint.

C.O. 1 Given a blueprint of house (detail of outside finish), the student will identify the type of finish required.

Task 2. Prepares staging.

C.O. 1 See Task 13, C.O. 1 and 2, Framing.

Task 3. Installs required trim.

C.O. 1 Given a required trim (open or box type--specified on the blueprint), trim-finish material, hammer, nails, saw, hand plane, chalk line, and level, the student will fasten the finish to rafters.

Task 4. Computes amount of material required.

C.O. 1 Given specifications on a blueprint, the student will compute the amount of fascia material gutter, plancher molding, and board feet of lumber required to the nearest board feet.

Task 5. Consults blueprint for door sizes.

C.O. 1 Given blueprints which include the locations and dimensions of doors and windows, the student will identify these locations and dimensions and the number of doors and windows required.

Task 6. Procures materials and tools.

C.0. 1 Given specifications on a blueprint, the student identifies and procures the appropriate materials and tools required for doors and windows.

Task 7. Constructs door jambs (frames).

C.0. 1 Given blueprint specifications, materials, and tools, the student will measure and cut the materials to appropriate size and assemble the frame to size (within 1/16").

Task 8. Fastens and squares door jambs together.

C.0. 1 Given assembled door jambs, square, brace stick, hammer, and nails, the student will square the door jamb (frame) and tack-nail the brace stick (strong-back) from corner to corner.

C.0. 1 Given a squared door jamb (frame), a rough door opening, level, shims, straightedge, hammer, and finish nails, the student will insert the door jamb (frame) in the rough opening, and plumb and fasten it.

Task 9. Checks dimension of door jamb (frame).

C.0. 1 Given a placed door jamb, six-foot rule, straightedge, spirit level, and square, the student will measure for correct dimensions, squareness, plumb and straightness of the door jamb.

Task 10. Fits door.

- C.O. 1 Given a properly placed door jamb, door and appropriate tools (hammers, planes, straightedge, etc.), the student will cut, square, and bevel the door to correct size (within 1/8").

Task 11. Inserts hinges.

- C.O. 1 Given a properly fitted door, dimensions for placement of hinges, hinges, and tools (chisel, screwdriver, bit brace, etc.), the student will fit hinges to door and door jamb.
- C.O. 2 Given properly fitted hinges, screws, and necessary tools, the student will recess the hinge flush with the surface of the edge of the door, install screws.
- C.O. 3 Given a door with properly mounted hinges and necessary tools, the student will set hinges into the door jamb, flush with the surface of the door jamb (allowing for 1/16" clearance) and install the screws.
- C.O. 4 Given installed hinges on door and door jambs and pins, the student will mount door on door frame, insert pins in hinges and check the clearance and fit of door.

Task 12. Inserts locksets.

- C.O. 1 Given lockset, instructions, mounted door and appropriate tools (square, auger bit, etc.), the student will insert the locksets according to the instructions so that the bolt is positioned properly in the striker plate.

Task 13. Checks alignment of lockset.

C.0. 1 Given an installed lockset, the student will check the alignment of the bolt and striker plate, making certain that the face of the door is flush with door jamb rabbet and that there is clearance between the bolt and striker plate.

Task 14. Reviews blueprints for window sizes and locations.

C.0. 1 Given a blueprint of a house, the student will identify the types, locations, and dimensions of windows.

Task 15. Constructs window frames.

C.0. 1 Given window dimensions, lumber, and necessary tools, the student will assemble the window frame to required size (within 1/16").

C.0. 2 Given an assembled window frame, brace or strongback, square, hammer, and nails, the student will square the window frame and brace it from corner to corner.

C.0. 3 Given a squared and braced window frame, hammer, spirit level, and nails, the student will position and fasten the frame in the opening, making certain that the window is level and plumb.

C.0. 4 Given an installed window frame, six-foot rule, and spirit level, the student will check the dimensions of the frame.

Task 16. Fits windows.

C.0. 1 Given an installed window frame, sash, plane, and rule, the student will plane the sash to fit the window frame to 1/16" clearance on each side.

C.O. 2 Given a fitted window placed in a frame, window stop, hammer, and nails, the student will tack-nail the temporary window-stop to prevent the window from falling out.

Task 17. Reviews blueprints for stairs.

C.O. 1 Given blueprints of a house, the student will identify the rise (height) and the run of the stairs.

Task 18. Determines the height and length of stairs.

C.O. 1 Given the height and length of stairs, the student will compute the number of risers required.

C.O. 2 Given height, length, number of risers, required square, and pencils, the student will procure required stringer material and lay out the treads and rises.

Task 19. Cuts out stringers.

C.O. 1 Given layed out stringers, power or hand saw, the student will cut out the waste material.

Task 20. Erects stringers in place.

C.O. 1 Given cut-out stringers, spirit level, hammer, and spikes (20d), the student will fasten stringers in place so that they are level.

Task 21. Installs riser finish.

C.O. 1 Given installed stringers, riser finish, saw, plane, rule, hammer, and nails, the student will measure and cut the lumber to length and width and fasten in place.

Framer 860.381

Task 1. Reviews blueprint.

C.O. 1 Given a blueprint of a house, the student will identify the type and amount of wall board material required (amount to the nearest square foot).

C.O. 2 Given blueprints indicating all elevations and details (kitchens, openings, recommended construction, etc.), the student will identify the location and dimensions of rooms, floor joists, carrying beams, and sills.

Task 2. Installs sills.

C.O. 1 Given a poured foundation and lumber, the student cuts lumber to length and joins the cut lumber at points in a way which minimizes waste.

C.O. 2 Given installed sills, tools, leveling devices, and slate or shingle material, the student levels the sills by placing the slate or shingle material approximately three feet apart.

Task 3. Installs carrying beam.

C.O. 1 Given a leveled sill, 2 x 4 jack material, and carrying beam material, the student installs the carrying beam level with sills, locating the jack approximately 10 feet apart and one jack as close to the joint as possible.

Task 4. Nails joists to carrying beams and sills.

C.O. 1 Given installed carrying beams and sills and joist location, the student nails the joists in place to the nearest 1/4".

Task 5. Inserts joist bracing.

C.O. 1 Given installed joists, hammer, nails, and joist bracing (rough flooring material), the student tack-nails joist bracing to every joist.

Task 6. Applies (installs) sub-floor to joists.

C.O. 1 Given installed joists, openings (stairwells, fireplaces, chimneys, etc.), rough flooring material and necessary tools, the student will nail rough boarding to joists either at 45-degree or 90-degree angle to the joist or nail 5/8 inch plywood at 45-degree or 90-degree angles to joist (optional).

Task 7. Erects corner posts.

C.O. 1 Given ceiling height dimensions, lumber, tools (spirit level, hammer, saws, straightedge), the student cuts required number of corner posts to size and erects and braces them plumb.

Task 8. Erects plates and studs for outside walls.

C.O. 1 Given a plate with required stud locations, lumber, and necessary tools, the student will cut the required number of studs for all the outside walls to correct length and nail the studs to the plate.

C.O. 2 Given a stud-assembled plate and one-inch stock for wall braces and tools, the student will erect the wall by raising the wall into position and tying the wall to the corner post and brace to approximate plumb position. (This must be done for all outside walls.)

Task 9. Inserts headers for openings such as windows, doors, etc.

C.O. 1 Given erected walls with correct openings between studs for windows and doors, etc., template for window heights, header material and necessary tools, the student will cut the headers to correct lengths for all openings and nail them in template marked positions.

Task 10. Erects main partitions.

C.O. 1 See Task 8, C.O. 1 and 2.

Task 11. Places and nails ceiling joists.

C.O. 1 See Task 5, C.O. 1.

Task 12. Installs room partitions.

C.O. 1 See Task 8, C.O. 1 and 2.

Task 13. Installs stage brackets.

C.O. 1 Given a partially boarded up wall, wall brackets, hand drill, the student locates and drills holes in the wallboard high enough for accessibility and maximum height.

C.O. 2 Given located and drilled holes and wall brackets, the student inserts brackets through holes, clamps, and braces in place.

Task 14. Determines length of rafters.

C.O. 1 Given a blueprint which includes the pitch of the roof, the student determines the length and angle cut of the rafters.

Task 15. Cuts rafters to size.

C.O. 1 Given the length and angle of rafters, lumber, framing square and saw, the student cuts the required number of rafters to the appropriate size (including the notches).

Task 16. Erects end rafters.

C.O. 1 Given rafters cut to correct size, ridge board, plumb bob or spirit level, straightedge, hammer, and nails, the student erects the end rafter by nailing the rafters to the ridge board and the side walls.

C.O. 2 Given erected end rafters, plumb bob or spirit level, straight-edge, hammer, nails, and lumber, the student moves the end rafters until they are in plumb and then braces them.

Task 17. Installs rafters.

C.O. 1 Given erected end rafters and ridge boards, lumber, hammer, nails, and proper instructions, the student nails the required rafters into marked positions leaving openings for dormers and chimneys, if necessary.

Task 18. Fastens collar ties (rafter braces).

C.O. 1 Given erected rafters, ceiling height, collar ties of appropriate dimensions, hammer, and nails, the student nails the collar ties to the rafters.

Lather 342.781

Task 1. Reviews blueprint for type and amount of material required.

C.O. 1 Given a blueprint of a house, the student will identify the type and amount of wallboard material required (amount to the nearest square foot).

Task 2. Installs rock-lath.

C.O. 1 Given a studded 8 x 8 room, rock-lath, hammer, and nails, the student will apply rock-lath to ceiling and walls so that the joints will be staggered and the lath will be straight.

C.O. 2 Given installed rock-lath, corner beads and grounds, hammer, and nails, the student will fasten the corner beads and grounds so that there will be room for 3/4" of plaster.

Task 3. Installs drywall (rock, gypsum, etc.) panels.

C.O. 1 Given drywall paneling, blueprint specifications, scribe, saw, knife, level, straightedge, and six-foot rule, the student will measure, scribe, and cut the drywall paneling to size.

C.O. 2 Given drywall paneling cut to size, straightedge, level, hammer, and nails, the student will fasten the paneling to studs so that they are in plumb.

Task 4. Installs metal lath.

C.O. 1 Given a studded area, metal lath, hammer, and nails, the student will apply metal lath to the ceiling and walls so that each piece will be stretched tight and straight with overlapped joints.

Roofer 866.381

Task 1. Computes amounts of roofing material required.

C.O. 1 Given roof dimensions, the student will compute the amount of roofing material required to cover the entire area of the roof to the nearest 30 square feet.

Task 2. Prepares staging.

C.O. 1 See Task 13, C.O. 1 and 2 (Framer).

Task 3. Removes old roofing material.

C.O. 1 Given a roof with worn or damaged roof covering, pinch bar and claw hammer, the student removes the roofing material by pulling the roofing nails with pinch bar and/or claw hammer until only the plain wood surface remains.

Task 4. Computes spacing (amount shingle exposure to weather)

C.O. 1 Given a roof area covered with underlayment, chalk line, and six-foot rule or tape, the student will compute and mark off the spacing on both ends of the roof and then snap off the required number of lines with a chalk line.

Task 5. Applies first the first course (layer of wood shingle at gutter).

C.O. 1 Given a roof ready for covering, wood shingles, chalk line, hammer and shingle nails, the student will fasten a course of wood shingles to the gutter edge of the roof, keeping the shingle in a straight line parallel to the roof and/or gutter.

Task 6. Applies shingles as marked for spacing.

C.O. 1 Given marked off roof, wood shingles, roll material or asphalt shingles, hammer, and roofing nails, the student fastens the roof material by positioning it on marked lines and nailing it in place.

Task 7. Erects roof brackets for staging.

C.O. 1 Given a partially covered roof, roof brackets, hammer, and 6 d nails, the student will nail the bracket to a roof rafter and then adjust the bracket to the pitch of the roof (approximately at right angles to the roof).

Task 8. Applies flashing.

C.O. 1 Given roof locations requiring flashing (valleys, dormers, steps, etc.), flashing material, tin snips, and six-foot rule, the student will measure the amount of flashing required, cut it to size, and position it in place, starting at the bottom of the slope and placing top sections overlapping the bottom sections.

Task 9. Prepares bill or invoice

C.O. 1 Given a completed roof (materials used, time finish job, etc.), the student will compute the cost of the job.

Siding Applicator 863.884

Task 1. Reviews blueprint.

C.O. 1 Given a blueprint of a house, the student will identify the type and amount of siding required.

Task 2. Prepares scaffolding (wood).

C.O. 1 Given a ten-foot high and ten-foot wide wall, lumber (2 x 4), saw, straightedge, level, hammer, and nails, the student will erect uprights and supports which will be braced plumb to an eight-foot straightedge.

C.O. 2 Given erected uprights and supports, ledger boards, braces, saw, hammer, and nails, the student will locate and fasten the ledger boards to the structure.

C.O. 3 Given erected scaffold structure, lumber (2 x 10), hammer, and nails, the student will place the 2 x 10 boards on the ledger boards and tack in place.

Task 3. Prepares scaffolding (staging brackets).

C.O. 1 See Task 13, C.O. 1 and 2 (Framer).

Task 4. Computes spacing for courses of clapboard.

C.O. 1 Given a 26 x 45 garrison-type house, a six-foot rule, snap line, leveling device, and straightedge, the student will measure the side of the house and compute spacing and number of courses of siding material required to cover the side(s).

Task 5. Applies underlayment clapboards.

C.O. 1 Given a 26 x 45 garrison-type house ready for siding, scaffolding, clapboards, and siding tools, the student will locate the lowest point above the foundation and from this point locate a level line around the building.

- C.O. 2 Given the lowest point above the foundation and a level line around the building from this point, water-table and drip-board material and siding tools, the student will fasten the water table and drip board so that they will be level throughout the distance of the house.
- C.O. 3 Given installed water table and drip board, marked off side of house, siding materials, and siding tools. the student will build up the corners so that they will be plumb with course lines.
- C.O. 4 Given erected corner, straightedge or strapping, siding material and siding tools, the student will fasten the siding materials flush with the straightedge which is positioned on the scrapped chalk line chairline joints where the siding meets or abutts.

Tile Applicator 861.781

Task 1. Computes kind and amount of material required.

- C.O. 1 Given instructions by the foreman or customer as to what type of tile is required, the student will identify the type of material specified.
- C.O. 2 Given an area (room, hallway, etc.), which requires tile application, paper, pencil and six-foot rule, the student will measure the area and compute the square footage to the nearest square foot.

Task 2. Locates center lines of floor and/or walls.

C.O. 1 Given an area requiring tile application, six-foot rule, and chalk line, the student will measure the area, locate the horizontal centerline and a perpendicular line which bisects the horizontal line.

Task 3. Locates lowest point on the wall.

C.O. 1 Given a wall requiring tile application, straightedge, and spirit level, the student will locate the lowest point on the wall.

C.O. 2 Given the lowest point on a wall, spirit level, chalk line, straightedge, and several tiles, the student will establish the first course of tile so that it will be level.

Task 4. Check linearity of joints.

C.O. 1 Given applied tile, mallet, level, and straightedge, the student will check the linearity and plumb of joints so that all joints will be level or plumb.

MILL CARPENTRY

Assembly Man 763.884

Task 1. Reviews blueprint.

C.0. 1 Given an isometric sketch of an upper cabinet 12" x 32" x 36" with each part labeled and a blueprint of the same with dimensions missing, the student will extract from the sketch the parts of the job and write their dimensions in their proper places on the blueprint within 45 minutes.

Task 2. Cleans assembly area.

C.0. 1 Given an assembly area cluttered with rags, clamps and pieces of wood, the learner must clean the assembly area and arrange his clamps in an appropriate manner for easy procurement within 15 minutes.

Task 3. Procures materials and tools.

C.0. 1 Given a blueprint of a 12 x 32 x 36 birch wall cabinet, clamps, glue and standard small hand tools, the worker must gather all parts of the job and position them for gluing in 15 minutes.

Task 4. Lays out parts according to order of assembly.

C.0. 1 Given a sketch of blueprint and job parts for 12' x 32" x 36" wall cabinet, the learner will arrange the parts so that they will be assembled in order in 15 minutes.

Task 5. Applies glue to joints.

C.O. 1 Given parts of a face frame for 12" x 32 x 36 wall cabinet, glue and clamps, the learner must apply glue to the joints, clamping the frame together, square the opening, wipe off excessive glue and allow to set until dry. He must then clean assembly area.

Task 6. Computes Invoice.

C.O. 1 Given a time card, the student must add up all his time and materials used.

Boat Building 860.381

Task 1. Identifies boat sections.

C.O. 1 Given sketches of sections in stages of construction of a boat with each part or member labeled on the sketch and a blueprint of a similar boat, the student must extract and list each part from the blueprint and write its size.

Task 2. Lays out frames, keel, etc. to full size.

C.O. 1 Given a blueprint of 18' cabin cruiser, drawing, lofting paper and standard drawing tools, the student must draw to scale the half sections of all the frames and transom, the keel and the stem with a tolerance of $\pm 1/32$ in 12 hours.

Task 3. Makes templates.

C.O. 1 Given template material and above criteria, transfer layouts of scale drawings to template stock and cut out templates to coincide to layouts.

Task 4. Erects trestle.

C.O. 1 Given templates of frames, stem and keel of an 18' cabin cruiser, the student will clear area for fabricator and erect a trestle level so that the bubble will fit between two hairlines.

Task 5. Mills out stock.

C.O. 1 Given a drawing or sketch for a trestle on which will be built an 18' cruiser and standard woodwork machinery, mill out two longitudinal stringers $1\frac{3}{4} \times 4' \times 10'$, three lateral members and two transom posts within a tolerance of $\pm 1/32$.

Task 6. Fashions and assembles stem and keel.

C.O. 1 Given a positioned trestle, templates of keel and stem and a blueprint for an 18' cabin cruiser, the student must cut to shape and fasten stem and keel to blueprint requirements on the trestle.

Task 7. Steam bends ribs.

C.O. 1 Given a form and white oak rib stock and a steam box, the learner must steam and bend rib stock to fit contour of form to tolerance of $\pm 1/32$.

Task 8. Marks off frame locations.

C.O. 1 Given a blueprint for an 18' cabin cruiser and necessary tools, mark off rib or frame locations on keel to blueprint specifications within $1/32$.

Task 9. Cuts out ribs to desired shape.

C.O. 1 Given frame template and layout of an 18' cabin cruiser, the student will mill, cut to shape, and fasten all frames to fit layouts to within 1/32.

Task 10. Installs ribs or frames.

C.O. 1 Given ribs cut or steamed to shape, the student must set up, fasten, and brace the frames or ribs on keel location, plumb and level (bubble must center between hairlines).

Task 11. Fastens frame with proper fasteners.

C.O. 1 Given a white oak frame for 18' cabin cruiser, the holding power of screws, screw nails and bolts, and the action of salt water on galvanized iron, iron, bronze, and their properties, the student will identify the proper fastener to use and tell why, then fasten frames to keel.

Task 12. Mills out chines and battens.

C.O. 1 Given stock and blueprint, the student must extract the part from the blueprint, cut it to size, make the necessary cut-out in frames to receive battens and chines and fasten them in place with proper screws.

Task 13. Fares chines and battens.

C.O. 1 Given battens and chines fitted and fastened in place, but not trimmed flush with edge of frame, the student will trim or fare battens and chines so that they will be flush as possible with all frames and keel.

Task 14. Checks accuracy of work.

C.O. 1 Given a blueprint and assembled frame work of an 18' cruiser, the student must identify each part and its dimension.

Task 15. Applies planking.

C.O. 1 Given blueprint and framework of an 18' cruiser ready for planking, the student must apply planking to the framework to $\pm 1/16''$.

Task 16. Lays out template for plywood planking.

C.O. 1 Given bottom framework ready for plywood planking on an 18' cruiser, the student must obtain heavy paper templates of sides, if necessary, of the bottom and side to fit framework.

C.O. 2 Given templates of bottom and side and the formula $A-LXW$, the student must compute the amount of plywood or planking required and cut to the templates.

Task 17. Determines the shape of planks by spiling.

C.O. 1 Given a framework, a spiling board, and instructions and demonstrations on spiling, the student must spile planking to fit contour of boat.

Task 18. Identifies steps needed to apply trim, hardware and finish.

C.O. 1 Given a blueprint of an 18' cruiser, a cruiser planked and ready for trim, the student will identify the steps necessary to install hardware, trim and inside finish.

Task 19. Caulks all seams and screw holes.

C.O. 1 Given a demonstration showing examples of effects of water on exposed screws, seams, and appearance, the student must caulk or fill in all cavities and exposed screw holes with caulking material or wood plugs.

Task 20. Constructs stringers, bulkheads, compartments, decking, superstructures, and sheathing.

C.O. 1 Given blueprint and hull of an 18' cabin cruiser, the student must construct and fit all interior stringers, bulkheads, compartments, decking, superstructures and sheathing from templates when necessary.

Task 21. Plugs all screws.

C.O. 1 Given a demonstration on why and how we use wood plugs, a piece of mahogany decking with 6 5/8" holes, the student will make six plugs, using a plug cutter, and insert them in the holes with glue, so that the grain of the wood is in the proper direction and finally chisel and sand the plugs smooth.

Task 22. Installs hardware.

C.O. 1 Given a 6" boat cleat and a 6" boat chock, the student must locate, bed, drill pilot holes, and fasten the cleat and chock securely in one-half hour.

Task 23. Lays out waterline.

C.O. 1 Given a pair of horses, a snap line, a level, a blueprint, and a transit, the student must lay out and scribe the waterline using three methods in 45 minutes.

Task 24. Sands boat surface.

C.O. 1 Given the decking of an 18' cabin cruiser, No. 0 and No. 000 garnet sandpaper, the student will sand the decking clean and smooth in one-half hour.

Task 25. Paints boat surfaces.

C.O. 1 Given an 18' cabin cruiser, the student must paint the cruiser to specifications and to a smooth, neat appearance.

Task 26. Applies fiberglass.

C.O. 1 Given a demonstration on the use of fiberglass, glass cloth and resin with other necessary materials such as a piece of 1/2 plywood, the student must apply fiberglass to the plywood.

Task 27. Sands fiberglass.

C.O. 1 Given a 4 x 4 piece of 1/4 plywood on which fiberglass has been applied, power sander, file and sandpaper, worker must sand the fiberglass very smooth and even to the touch in one hour.

Task 28. Sands, putties, and paints holes in fiberglass.

C.O. 1 Given three pieces of 1/4 x 3/4 plywood, two of which are just sanded smooth, the other a layer of fiberglass sanded smooth, stained and painted, the student must apply a coat of filler stain to one, brush primer on one, and spray the fiberglass within 45 minutes.

Task 29. Sprays sealer and applies paints.

C.O. 1 Given the above and a spray gun, the student will spray clear sealer on the stained piece and the fiberglassed piece, and brush a coat of paint on the other in thirty minutes.

Cabinet Installer 860.381

Task 1. Identifies locations of cabinets.

Task 2. Installs upper cabinets.

C.O. 1 Given assembled upper cabinets, scribe, saw, hammer and nails, the student will fit the cabinets in place by scribing and cutting to contour of the walls and fastening the cabinets in place.

Task 3. Fastens molding and trim.

C.O. 1 See Task 2, C.O. 1 & 2 and Task 3, C.O. 1 under Finishman (inside).

Task 4. Putties up holes.

C.0. 1 Given installed upper cabinets and trim, putty knife, and filler material, the student will fill in all cavities with the filler material so that it will be flush with the finish surface.

Task 5. Locates counters.

C.0. 1 Given blueprint of a house, the student will identify the location of counters.

Task 6. Installs counters.

C.0. 1 Given location of counters, assembled counters, and counter tops, scribe, saw, hammer and nails, the student will scribe and cut counters and counter tops to contour of walls, and fasten them in place.

Task 7. Installs molding and trim.

C.0. 1 See Task 2, C.0. 1 and 2 and Task 3, C.0. 1 under Finishman (inside).

Task 8. Cleans and sandpapers work.

C.0. 1 Given installed cabinets, counters and counter tops, sandpaper and turpentine, the student will clean all surfaces with turpentine and sandpaper all surfaces until they are clean and smooth.

Formica Installer 763.884

Task 1. Installs Formica

C.0. 1 Given a 26 x 10' counter top, plastic, adhesive and basic tools, the learner must cut the laminate to fit the counter edges and counter, apply the adhesive to the bottom surface of the plastic, top surface of the counter top, position and adhere plastic to top, and trim edges so that the plastic is flat, firmly adhered and pleasing to the eye in three hours.

Task 2. Cleans Installation.

C.0. 1 Given above and cleaning solvent with cloths, the student must clean the plastic of any dirt, glue or printing to a clean new luster in 1/2 hour.

Furniture Maker 763.884

Task 1. Lays out templates.

C.0. 1 Given a blueprint or drawing of any piece of furniture, the worker must make the necessary layout and templates to within $\pm 1/64$, make a stock list and the size of each part.

Task 2. Fabricates stock to required dimensions.

C.0. 1 Given required templates and necessary tools, the student will mill the stock to size, make up Joints and shapes by using jointing machines and shaping machines as well as make up any necessary jigs which the job may require.

Task 3. Assembles furniture.

C.0. 1 Given stock fabricated to required dimensions, glue, stain, polish, and required tools and equipment, the student will glue and assemble, stain and spray, and polish the job to trade requirements.

Task 4. Computes costs of furniture making.

C.0. 1 Given a time card and the formula $BDFT = \frac{TWL}{T2}$ the student will compute his time and amount of material or stock used on the job.

Hardware Applicator 763.884

Task 1. Installs Hardware.

C.0. 1 Given a 12 x 32 x 36 wall cabinet ready for hardware applications, hardware, basic tools, the student must apply and fasten hinges, catches, and handles by marking locations, spotting screw holes, drilling pilot holes for screws and fastening this hardware so that the door will be aligned perfectly straight, even and pleasing to the eye within two hours.

C.0. 2 Given a time card, the learner must list time and any material used.

Interior Designer 142.051

Task 1. Estimates jobs.

C.0. 1 Given a selection of jobs, student must compute the cost of materials and labor involved to give a cost estimation for each job.

Task 2. Designs fixtures and furniture.

C.0. 1 Given photograph of interiors, worker must design and arrange as many possible ways that he can think of for improving its interior design so that it is eye-appealing, practical and infers a comfortable atmosphere.

Task 3. Consults customers.

C.0. 1 Given a customer inquiring on remodeling suggestions, the pupil must suggest renovations acceptable to customer.

Task 4. Makes sketches and drawings.

C.0. 1 Given customer's desires and suggestions, student must make drawing and sketches of suggested renovations.

Task 5. Supervises installations.

C.0. 1 Given a job requiring several workers, the student must organize the schedule of workers so that job is completed in the least amount of time and interference from start to finish.

Task 6. Prepares dimensions. (details of work)

C.0. 1 Given accepted drawing for renovations, pupil must draw up a detailed drawing to scale with dimensions.

Task 7. Computes time and labor for profit or loss.

C.0. 1 Given a completed job, the student computes cost of materials and labor to the nearest dollar.

Kitchen Cabinet Maker 660.280

Task 1. Cuts out stock to required dimensions.

C.0. 1 Given a sketch or blueprint of kitchen, layout, stock list and templates, the student must mill out all stiles, rails and mutins to size and mill the type of joint used.

Task 2. Assembles cabinets.

C.0. 1 Given stock cut out to size, glue, and necessary tools, the student will cut out the doors and attach face frames.

Task 3. Installs shelving and hardware.

C.0. 1 Given assembled cabinets, hardware and necessary tools, the student will arrange for adjustable shelves, attach soffits and molding on uppers and fit the counter top.

Layout Man 761.381

Task 1. Lays out job to dimensions.

C.0. 1 Given a blueprint of a counter 10' long with 6 door openings, sink and 4 drawers, the student must extract measurements, acquire a layout stick and layout to scale the heights, lengths and widths of the counter to within $\pm 1/32$.

Mill Man 669.380

Task 1. Operates woodworking machines.

C.0. 1 Given a variety of shapes, joints, and sizes and woodwork machines, the worker must be able to sharpen and grind cutters to shape and set up the following to make the job to specifications, templates and layouts to $\pm 1/32$.

- | | |
|-------------------|----------------------------------|
| A. Circular saw | F. Mortiser |
| B. Surface planer | G. Molder |
| C. Shaper | H. Sander (Sprindle, Disc, belt) |
| D. Borer | I. Jointer |
| E. Tenoner | |

Mill Man - Wood Former 669.380

Task 1. Makes up a forming block.

C.0. 1 Given a blueprint of 60" archery bow, layout tools, pine stock and basic woodworking tools, the student must dress the stock to rough $\pm 1/2$ " large enough to lay out the outer and inner part of the bow in half an hour.

Task 2. Fabricates a Forming Block.

C.0. 1 Given the above but 100 or more of the bows are to be made, the learner will fabricate from wood and aluminum plate and inner and outer form of the bow to dimensions on blueprint to a tolerance of $\pm 1/32$ ".

Task 3. Cuts and shapes form block to size.

C.0. 1 Given Task 1, C.0. 1, the student will use this stock to lay-out and cut out to within $\pm 1/16$ " to be used as a forming block.

Task 4. Computes and mills out laminated material needed.

C.O. 1 Given a demonstration, samples and method of wood forming, the student will compute the amount of 1/16" birch laminate required and proceed to mill this amount out for 60" bow.

Task 5. Steams material to be formed.

C.O. 1 Given a piece of 3/4 x 2 x 66" birch, a steam box, form block for 60" bow, clamps and a demonstration on steam bending, the learner will steam and bend the piece to shape using the form block.

Paint and Stain Maker 550.885

Task 1. Paints and refinishes furniture.

C.O. 1 Given a Duncan Phyfe chair to be refinished, stain to be mixed to match the rest of the chairs, color and colorcharts being provided, the student must mix color or pigments to match sample and then the stain or paint to consistency for application.

Sash and Door Carpenter 669.380

Task 1. Fabricates doors and sashes.

C.O. 1 Given a 28 x 7' 6" door sketch, standard woodworking machines, the learner must make a stock list, procure all the stock required, will cut out all the stiles to size, lay out mortise and tenon joints, groove out for paneling, mill out paneling and glue, assemble the job to specifications.

Task 2. Installs glass.

C.O. 1 Given sash with 8 x 10 glass size, glass putty and standard tools, the learner must cut the glass to size, insert glazing points, and putty the glass to form a tight seal, and bevel the putty with a putty knife from the top of the rabbet to a feather edge.

Spray and Finisher 763.381

Task 1. Determines equipment and supplies required.

C.O. 1 Given a 12 x 32 x 36 wall cabinet and 26" x 36" x 10' counter, spraying equipment and masking tape, the learner must compute the amount of paint materials required for the job, sand and de-wax the job and repair the surface.

Task 2. Paints assemblies.

C.O. 1 Given the necessary equipment and supplies, the student will mask hardware, mix color stain required and apply it or primer to the job, putty up holes with color putty or putty stick, sand smooth and apply a second coat of sealer.

Task 3. Applies additional coats (if necessary).

C.O. 1 Given assemblies already sprayed, the student will then sand and apply a third coat, if necessary, and finally rub it down smooth to the touch by using steel wool and wax or pumice and polish to a smooth luster.

Wood Turner 664.782

Task 1. Turns wood to shape.

C.O. 1 Given a blueprint of any turning, lathe, required tools and material, and templates, the student must turn between centers or on a face plate to a size within $\pm 1/32$.

Task 2. Sands and seals turning.

C.O. 1 Given turned stocks, sandpaper and sealer, the student will sand the stock smooth and apply the sealer to the surface.

PATTERNMAKING

Model Maker 661.380

Task 1. Reads blueprint and constructs layout.

C.O. 1 Given a blueprint of a pattern, the student will construct the layout for the parts and match it to the sample or the master layout. (Time limits will be determined by patterns to be layed out).

Task 2. Identifies materials to be used on a job.

C.O. 1 Given pieces of maple, birch, pine, mahogany, and white wood, the student will identify each in a total of one minute.

Task 3. Identifies the scale required.

C.O. 1 Given a blueprint of a pattern, the student will identify the scale required for making the pattern.

Task 4. Breaks job down into parts or sections.

C.O. 1 Given a blueprint of a pattern, the student will identify the parts and their dimensions and add $1/4''$ to each dimension for cutting-off material (Time limits will be determined by the patterns.)

Task 5. Draws layouts and templates.

C.O. 1 Given a blueprint of a pattern, scratch gage, knife, pencil, hand plane, and a pair of dividers, the student will construct a layout and templates to tolerance of $\pm 1/64''$. (Time limits will be determined by the pattern.)

Task 6. Mills and dresses stock to size.

C.O. 1 Given pieces of stock, hand tools and measuring tools, the student will mill, dress, or cut the stock to size indicated by the layout to a tolerance of $\pm 1/64''$. (Time limits will be determined by the pattern.)

Task 7. Glues and assembles parts of patterns or models.

C.O. 1 Given a rule, glue, layout, brads and dressed stock, the student will glue and assemble the parts together to fit the layout and to measure to the blueprint to a tolerance of $\pm 1/64''$. (Time will be determined by the job.)

Task 8. Checks for accuracy and location of parts.

C.O. 1 Given a blueprint of a model or pattern, the model or pattern, the student will measure the parts to conform with the blueprint. (Time limits are determined by the job.)

Task 9. Lays out details and paints.

C.O. 1 Given a blueprint of a model or pattern, the model or pattern, layout tools, color code, brush, and laquers (red, black, yellow and clear), the student will layout the detail lines and laquer the model or pattern according to blueprint specifications. (Time limits are determined by model or pattern.)

Task 10. Computes time and material costs for invoicing.

C.O. 1 Given the formula:

$$\frac{L' \times W' \times T'}{12} = \text{Bd. Ft.}$$

hourly rates, pencil and paper, the student will compute the cost of constructing a model or pattern.

Task 11. Cuts out cavities.

C.O. 1 Given a piece of wood $\frac{1}{4} \times 8 \times 12$ with a round hole 4" diameter layed out in the center and standard woodworking tools, the student will cut out the hole with a \pm tolerance of $1/64$ ", in $\frac{1}{2}$ hr.

Task 12. Cleans and sands surfaces.

C.O. 1 Given a 6 x 12 surface plate mockup, 1 piece of No. 80 sandpaper, a piece of No. 100 garnet paper, fillet gage, and a sanding block, the student will sand the plates, and must clean and smooth all surfaces perfectly flat without scratch marks. (All sharp corners should be broken to $1/32$ radius in $\frac{1}{2}$ hr.)

Task 13. Determines parting for molding.

C.O. 1 Given a 6 x 12 surface plate pattern, the student will identify which part is the cope and which is the drag.

Task 14. Lays out parting lines and cores.

C.O. 1 Given a layout of a 6 x 12 surface plate, blueprints, layout board and necessary layout tools, the student will layout parting lines and coreprints.

Task 15. to Task 20.

Not written out because they are identical to tasks in Basic Woodworking.

Pattern Rigger 801.884

Task 21. Locates match holes.

C.O. 1 Given a split pattern and match board cut to flask size, the student will position the pattern on the board and locate the match holes.

Task 22. Drills match holes through the cope and drag.

C.O. 1 Given located match holes and a drill, the student will drill the match holes through the match board.

Task 23. Aligns both halves of pattern:

C.O. 1 Given located and drilled match holes and dowel pins, the student will align the halves of the pattern by inserting dowel pins in each half and then fastening these to the match board.

Task 24. Makes up cope and drag board to sizes.

C.O. 1 Given a sketch of a cope and drag board set, standard woodworking tools and machines, the student will construct a cope board and a drag board to specifications so that each will be smooth and flat (in three hours).

Task 25. Lays out flask centers on both the cope and the drag board.

C.O. 1 Given a cope and drag board set, pins and plates, and standard woodworking hand tools and machines, the student will insert the pins in the cope board and plates in the drag board to fix the foundry flock (in at least two hours).

Task 26. Locates and tacks drag pattern to drag board and drills the match hole through the board.

C.O. 1 Given a set of cope and drag boards with pins and plates, the student will drill the cope and drag boards.

Task 27. Locates the pattern halves on the cope and drag boards and fastens together.

C.O. 1 Given a matched cope and drag board set, pattern halves, hand tools and screws, the student will locate or match the pattern halves on the cope and drag board and fasten the assembly with screws so that both halves of the pattern will match perfectly.

Task 28. Constructs gating.

C.O. 1 Given instructions to shape a gate and a runner to foundry standards, hand tools and woodworking tools, the student shapes the gate and runner to stated specifications.

Pattern Finisher 661.281

Task 29. Sands patterns.

C.O. 1 Given a pine pattern of an angular block, lacquer, sanding block and garnet paper, the student will sand the pattern smooth, fill in any imperfections and lacquer to a clean smooth finish.

Task 30. Procures correct size fillet and fillet iron and insert fillet.

C.O. 1 Given a pine bracket pattern without fillets, one coat of sealer or lacquer on the pattern and a number of different sized fillets, the student will identify the No. 3 or 3/16 R and insert this into all corners so that they will be clean and smooth to the touch.

Task 31. Attaches identification tags.

C.O. 1 Given a part number, job number, metal stamps and/or an embossing machine, the student will stamp on the pattern or emboss on the tag the part number, job number and the name of the company. (If a tag is embossed, the student will attach the tag to the pattern in a straight, orderly fashion.)

Plaster Patternmaking 777.381

Task 32. Selects plaster area and procures materials and equipment needed.

C.O. 1 Given a plaster area and bench littered with bits of plaster and wood, scrapers, cloths, water, dust pan and brush, the student will clean and wash the bench, remove unusable material and replace any material that needs to be replaced.

Task 33. Constructs framing.

C.O. 1 Given a blueprint of a 6" tee pattern and corebox, the student will construct the necessary framing and templates for duplicating the job in plaster.

Task 34. Computes the amount of plaster required and mixes it with water.

C.O.. 1 Given the above instructions and formulas, the student will compute the amount of plaster required and mix the plaster with water.

Task 35. Roughs forms the job and with the use of templates forms the shape to size.

C.O. 1 Given mixed plaster when it begins to gel, the student will pour the plaster into the frame and immediately rough form the pattern with paddles and shape to size with templates.

C.O. 2 Given a rough formed pattern, chisels, gouges and sandpaper, the student will trim and smooth the pattern to size.

Task 36. Installs corestick to a board.

C.O. 1 Given a corestick for a 6" tee, the student will fasten the corestick to a board to provide at least 1" of plaster around the corestick.

Task 37. Determines metal thickness of core box and builds a frame or flask around it.

C.O. 1 Given an installed corestick, measuring tools, handtools, and required material, the student will build a frame around the corestick $\frac{1}{4}$ " higher than the corestick.

Task 38. Coats the plug with a release agent and prepares for pouring plaster.

C.O. 1 Given a pattern and corebox ready for pouring and plaster release agent, the student will coat the entire surface of the core plug.

Task 39. Mixes plaster and water and pours the mixture into the flask.

C.O. 1 Given a pattern and corebox ready for pouring, plaster, and water, the student will compute the amount of plaster required, mix the plaster to a creamy consistency and pour the mixture into the frame.

Task 40. Strikes or shapes the mold with a template.

C.O. 1 Given a poured corebox and templates, the student will strike plaster to the desired shape with templates (as the plaster begins to gel).

Task 41. Withdraws plug from mold, smooths, if necessary, and allows it to dry overnight.

C.O. 1 Given a shaped, warm thermosetting mold and sandpaper, the student will withdraw the core plug, smooth it if necessary, and place it in an oven to dry overnight at 100° F.

Metal Patternmaker 600.280

Task 42. Uses correct shrink rule to check metal pattern or core box.

C.O. 1 Given two rough metal pattern castings (one made with the use of a shrink rule and the other with a common rule), machine shop tools (micrometers, vernier calipers, surface gage, etc.) and a metal core box for the job, the student will identify how each casting was prepared and compare the patterns with the core box for alignment and metal thicknesses to within .002 within one hour.

Task 43. Lays out center lines and finishing dimensions on a casting for machining.

C.0. 1 Given Prussian Blue, a blueprint and casting of a 3 x 4 shoulder bushing, the appropriate pattern, corebox and measuring tools, the student will lay out the center lines and finishing dimensions.

Task 44. Machines casting to size.

C.0. 1 Given a casting with center lines and finishing dimensions layed out, and appropriate metal-working machines, the student will machine the casting to required dimensions within .002 inches.

Task 45. Fills cavities with solder or other suitable material.

C.0. 1 Given two damaged castings, and an aluminum solder and plastic (with instructions on their use), the student will repair one casting with aluminum solder and the other with plastic so that the cavities are completely filled (within $\frac{1}{2}$ hr.).

Task 46. Files or machines all surfaces smooth, straight and flat to dimensions.

C.0. 1 Given a blueprint and layout, correlated castings, measuring instruments, and metal lathe, the student will turn patterns required dimensions within .002 inches.

C.0. 2 Given blueprints, coreboxes, milling machine and measuring instruments, the student will mill the coreboxes to dimensions to coincide with the patterns.

C.O. 3 Given blueprints, pattern coreboxes, aluminum files, scrapers, and measuring instruments, the student will file and scrape unmachinable parts flat, to a straight edge and smooth to the touch.

APPENDIX D

Performance Objectives
Basic Woodworking Core Program

BASIC WOODWORKING

Task 1. Reads blueprints.

- C.O. 1 Given a blueprint, the student interprets the meanings of various lines and symbols, identifies dimensions, and extracts the pertinent facts such as scales, materials required, etc.
- T.O. 1 Given a blueprint, the student identifies dimensions, and interprets the meaning of various lines and symbols.
- T.O. 2 Given a blueprint, the student identifies the dimensions, tolerances, and scales.
- T.O. 3 Given a blueprint, the student identifies all views given and the relationship between the views.
- T.O. 4 Given a blueprint, the student discriminates between isometric and orthographic projection and their applications.
- T.O. 5 Given a blueprint, the student extracts information from the title block (such as materials used, quantity, scale, etc.)

Task 2. Makes measurements with the 1, 3, and 6-foot rule.

- C.O. 1 Given a blueprint, stock or area to be measured, the student measures the required dimensions to $\pm 1/32$ inch.
- T.O. 1 Given a blueprint, prepared stock, and 1-foot, 3-foot, or 6-foot rule, the student measures the dimensions stated in the blueprint to $\pm 1/32$ inch.

Task 3. Computes dimensions.

- C.O. 1 Given a blueprint, the student computes the dimensions not indicated on the blueprint.
- T.O. 1 Given a blueprint and pencil and paper, the student computes any required dimensions not indicated on the blueprint by subtracting or adding segments.

Task 4. Uses square to check flatness and squareness.

- C.O. 1 Given a piece of planed stock and a square, the student positions the square on the stock and checks the flatness and squareness of the stock. (The blade of the square and the stock must be flush.)

- T.O. 1 Given a framing square and combination square, the student identifies each by its function and appearance.
- T.O. 2 Given a piece of planed stock and a square, the student checks the stock for flatness by placing the square on the surface (along the length, width, and from corner to corner), checking that the blade of the square is flush with all points.
- T.O. 3 Given a piece of prepared stock and a square, the student checks the squareness of the edges and ends by positioning the inside edges of the square head and square blade on the edges and ends of stock. (The stock must be flush with the edges of the head and the blade.)
- T.O. 4 Given two pieces of stock fastened together to form a square angle and a square, the student checks the squareness of the joint by positioning the outside edges of the blade and head on the inside of the joint and the inside edges of the blade and head on the outside of the joint. (All surfaces must be flush.)

Task 5. Makes stock lists.

- C.O. 1 Given a blueprint or drawing of a job and pencil and paper, the student makes up a stock list by computing board feet of lumber and listing all materials and hardware required.
- T.O. 1 Given a blueprint or a diagram of a job, pencil and a paper, the student makes a stock list by computing the board feet of lumber (to the nearest board feet) and all materials and hardware required.

Task 6. Saws lumber.

- C.O. 1 Given a piece of marked stock and various handsaws, the student selects the saw required to make the cut and cuts the stock along the marked lines.
- T.O. 1 Given various handsaws, the student identifies each by its appearance and function.
- T.O. 2 Given a piece of marked stock and a crosscut saw, the student saws the lumber to desired length along the markline (compensates for kerf).
- T.O. 3 Given a piece of marked stock and a rip saw, the student saws the lumber to desired width along the markline (compensates for kerf).
- T.O. 4 Given a piece of prepared and marked lumber, the student saws the lumber to desired shape along the cutting line, square to the surface.

Task 7. Uses hammer.

C.O. 1 Given a variety of hammers, nails, and stock to be nailed, the student selects a proper hammer and nails, and drives in the nails without damaging the stock or bending the nails.

T.O. 1 Given a variety of hammers, the student identifies each by its function, weight, and appearance.

T.O. 2 Given a claw hammer, nails, and stock, the student drives the nails into the stock without bending the nails or damaging the stock.

T.O. 3 Given a claw hammer, brads, and stock, the student drives the brads into the stock by toe-nailing (without bending brad or damaging the stock).

C.O. 2 Given a bent nail (driven in wood) and a claw hammer, the student removes the nail without damaging the stock.

T.O. 1 Given a bent nail (driven in wood) and a claw hammer, the student removes the nail from the wood without damaging the surface or hammer. (This can be accomplished by placing a piece of flat material between the head of the hammer and the surface of the stock.)

Task 8. Uses the bit brace.

C.O. 1 Given a bit brace and various bits, the student identifies the bits and installs them into the brace.

T.O. 1 Given a bit brace and various bits, the student associates the bits with their uses and installs bits into braces so that they are straight.

C.O. 2 Given a bit brace with an installed bit, the student bores or countersinks holes or tightens screws without damaging the stock, bit or screw heads.

T.O. 1 Given a bit brace and an installed auger bit and a piece of marked stock, the student bores a hole in the stock and prevents the splintering by backing the stock with scrap material or reversing the boring as soon as the spur penetrates the stock.

T.O. 2 Given a bit brace, an installed countersink, and stock with bored holes, the student countersinks the holes to form a 1/8 inch countersink or chamfer.

T.O. 3 Given a bit brace, an installed screwdriver bit, and partially installed screws, the student tightens the screws without damaging the screw heads, the stock, or the bit.

Task 9. Identifies lumber.

- C.O. 1 Given various samples of lumber, the student identifies each by its characteristics, grades, and uses.
- T.O. 1 Given several pieces of stock, the student will identify each piece by its color and grain structure.
- T.O. 2 Given several pieces of stock, the student states the grade by its labels and imperfections.
- T.O. 3 Given various pieces of identified stock, the student states the common application or uses of each.

Task 10. Planes lumber.

- C.O. 1 Given a variety of planes, the student identifies each plane and disassembles and assembles each.
- T.O. 1 Given various planes, the student identifies each by its characteristics and functions.
- T.O. 2 Given various planes, the student disassembles and assembles each and adjusts the blade to various depths.
- C.O. 2 Given a plane, grinder, India stone, and strop, the student sharpens the plane blade.
- T.O. 1 Given a plane blade, a grinder, #2 fine India bench stone, and a strop, the student sharpens the plane blade to a razor sharp edge.
- C.O. 3 Given a piece of marked stock to be planed and a variety of planes, the student selects the proper plane and planes the stock to desired dimensions.
- T.O. 1 Given a piece of stock to be planed and various planes, the student associates the type of plane with the planing required.
- T.O. 2 Given a selected plane and a piece of marked stock, the student planes the stock flat and smooth.

Task 11. Uses straightedge.

- C.O. 1 Given prepared stock and a straightedge, the student uses the straightedge to draw a straight line between two points and checks the surfaces and edges for flatness and straightness.
- T.O. 1 Given a straightedge, the student identifies its functions.

- T.O. 2 Given a straightedge and prepared stock, the student checks the flatness and straightness of the surfaces and the edges by placing the straightedge on the surfaces and the edges (straightedge and stock surfaces must be flush).
- T.O. 3 Given a straightedge, a prepared surface marked with center points, and a pencil or scribe, the student draws a straight line through the two points.

Task 12. Uses chisels.

- C.O. 1 Given a variety of chisels, mallet, dull chisel, and stock, the student identifies and sharpens the dull chisel and cuts to a line using the correct chisel.
 - T.O. 1 Given a variety of chisels, the student identifies each by appearance and function.
 - T.O. 2 Given a paring chisel and prepared stock with a radius cut out, the student secures the material to a bench and chisels to the line so that the radius will be smooth and square to the surfaces.
 - T.O. 3 Given a butt chisel, a mallet, and prepared stock with a recess layed out, the student chisels out the recess using a chisel and the mallet for rough cuts and finishes the cut with a paring chisel to the nearest 1/64".
 - T.O. 4 Given a chisel requiring grinding and sharpening, a grinder, a No. 2 fine India stone, and a strop or a buffer, the student grinds the cutting edge of the chisel (without burning it), whets the chisel on the stone, and strops it to a razor edge.

Task 13. Sands surfaces.

- C.O. 1 Given abrasive papers and stock, the student selects the appropriate grade and abrasive paper and sands the surface of lumber to desired smoothness.
 - T.O. 1 Given various samples of sandpaper, the student identifies the grades, types, and functions of the paper.
 - T.O. 2 Given a piece of stock to be sanded, and various pieces of sandpaper, the student selects the proper type of paper to be used to finish the stock to the smoothness desired.
 - T.O. 3 Given a piece of stock to be sanded and selected sandpaper, the student sands the stock to desired smoothness (sanding is done with the grain).

- T.O. 4 Given a pattern requiring sanding and selected sandpaper, the student sands the pattern to desired smoothness (sanding with the grain).

Task 14. Uses scribes.

- C.O. 1 Given various scribes, blueprint, stock, and measuring tools, the student identifies and selects the most appropriate sciber and scribes required lines.
 - T.O. 1 Given various scribes, the student identifies each by appearance and application.
 - T.O. 2 Given a piece of prepared stock to be scribed and various scribes, the student associates the proper scriber with the kind of scribing to be done.
 - T.O. 3 Given a piece of prepared stock to be scribed, a selected scribe, measuring tools, and a blueprint or sketch, the student scribes desired lines following the grain of the wood.

Task 15. Uses wood bits.

- C.O. 1 Given a selection of wood bits and stock with centerlines for holes, the student selects the most appropriate bit and drills the required holes without damaging the stock surfaces.
 - T.O. 1 Given four types of wood bits, the student differentiates between them by appearance and application.
 - T.O. 2 Given a piece of prepared stock with bore holes layed out and various wood bits, the student selects the proper bit to bore the hole.
 - T.O. 3 Given a piece of prepared stock with bore holes layed out and a selected wood bit, the student bores the hole in the stock and prevents splintering of wood by backing the stock with scrap material or by reversing the side of the stock when the spur penetrates the wood.

Task 16. Glues materials together.

- C.O. 1 Given a selection of glues, stock, clamps, and scrapers, the student identifies the glue required by a job, glues stock to specified width or thickness, and scrapes off excess glue with a glue scraper.
 - T.O. 1 Given various glues, the student identifies each characteristics and functions.

- T.O. 2 Given stock to be glued and various kinds of glues, the student selects the most appropriate glue to be used.
- T.O. 3 Given stock to be glued, selected glue, and clamps, the student spreads the glue on the stock, positions the joints, and clamps the stock with the appropriate clamps.
- T.O. 4 Given a glued assembly and a glue scraper, the student scrapes off all excess glue from the assembly.

Task 17. Uses the spirit level.

- C.O. 1 Given a spirit level and vertical and horizontal surfaces, the student uses the level and indicates whether or not the vertical surface is plumb and the horizontal surface level.
 - T.O. 1 Given a spirit level, the student states its various applications.
 - T.O. 2 Given a spirit level and a surface to be leveled (table, cabinet, etc.), the student positions the spirit level on the surface at various points to determine if the surface is level. (The bubble in the middle bubble indicator must have equal distance between the two lines.)
 - T.O. 3 Given a spirit level and a surface to be plumbed (vertical), the student positions the level on the surface at various points and determines plumb. (The bubbles in the two outside bubble indicators must have equal distance between the two lines on each indicator.)

Task 18. Operates the circular saw.

- C.O. 1 Given a circular saw, blades, stock, and a drawing, the student identifies the different types and sizes of blades and cuts stock to specifications.
 - T.O. 1 Given various circular saws, the student identifies each by blade size.
 - T.O. 2 Given the circular saw, the student identifies all its parts by appearance and function.
 - T.O. 3 Given various circular saw blades, the student identifies each by appearance and function.
 - T.O. 4 Given a piece of stock to be cut, the student associates the type of cut with appropriate saw blade and installs the blade in the saw so that the blade is tight.
 - T.O. 5 Given specific dimensions, a piece of stock to be cut, and a properly installed blade, the student makes all necessary adjustments to cut the stock to desired dimensions.

- T.O. 6 Given specified dimensions, a piece of stock and saw which is set up, the student makes the necessary cuts observing all safety precautions. (Rough work to $\pm 1/16''$ and finish work to $\pm 1/64''$.)

Task 19. Identifies lumber.

- C.O. 1 Given a selection of different kinds of woods, the student identifies and states the common use for each.
- T.O. 1 Given several pieces of stock, the student will identify each piece by its color and grain structure.
- T.O. 2 Given several pieces of stock, the student states the grade by its labels and imperfections.
- T.O. 3 Given various pieces of identified stock, the student states the common applications or uses of each.

Task 20. Uses layout tools.

- C.O. 1 Given a selection of layout tools, blueprint and stock, the student uses the correct tools and lays out a job to blueprint specifications.
- T.O. 1 Given various layout tools, the student identifies each by appearance and function.
- T.O. 2 Given a required layout (on paper, wood, or metal) a blueprint, and layout board, the student selects the appropriate tools to complete the layout.
- T.O. 3 Given a blueprint, selected layout tools, layout material (paper, wood, or metal, etc.) and a layout board, the student completes the layout to specifications in the blueprint.

Task 21. Computes costs.

- C.O. 1 Given time and cost of materials, the student computes the total cost of a job.
- T.O. 1 Given a stock list, time and labor costs, the student computes total partial costs to the nearest \$.01.

Task 22. Uses screwdrivers.

- C.O. 1 Given a selection of screwdrivers, screws, and stock, the student fastens two pieces of stock together using the appropriate screws and screwdriver.

- T.O. 1 Given a variety of hand screwdrivers, the student identifies each by size and shape of point and states the function of each.
- T.O. 2 Given two pieces of stock and screws, the student selects the appropriate screwdriver for applying the screws.
- T.O. 3 Given two pieces of stock, screws, and screwdriver, the student fastens the two pieces of stock as required without damaging the screw head, screwdriver tip, or the stock.

Task 23. Operates the band saw.

- C.O. 1 Given a band saw, a selection of blade types and sizes, and stock, the student selects an appropriate blade, mounts it in the machine and cuts the stock to specifications.
 - T.O. 1 Given a band saw machine, the student identifies it by its size and function.
 - T.O. 2 Given a band saw machine, the student identifies its parts and their functions.
 - T.O. 3 Given a variety of band saw blades, the student identifies each by width, length, and types of materials and cuts most appropriately used for.
 - T.O. 4 Given a selected band saw blade and band saw machine, the student installs the blade on the machine with the teeth facing the operator and the proper tension of the blade by being able to pull the blade sideways 1/4" with a minimum amount of pressure and adjusting the guide wheels so that the gullet of the saw teeth are 1/16" outward from the guide.
 - T.O. 5 Given a piece of marked stock, the student adjusts the table to the desired angle and the guide to proper height, activates the machine and makes the desired cuts, observing appropriate safety precautions, to the nearest 1/32".

Task 24. Applies sealer.

- C.O. 1 Given various kinds of sealers, sandpaper, and brushes, the student prepares a surface and applies the required number of coats of sealer.
 - T.O. 1 Given various kinds of sealers, the student identifies each by type and application.
 - T.O. 2 Given a prepared surface and various types of sealers, the student associates types of sealers with the requirement of the surface.

- T.O. 3 Given a prepared surface, selected sealer, and a brush, the student applies the sealer to the surface evenly so that an even film is formed.
- T.O. 4 Given a surface covered with a first coat of sealer, sandpaper, additional sealer, and a brush, the student sands the first coat of sealer and reapplies required number of sealer coats. (The surface must be even and smooth.)

Task 25. Uses files.

- C.O. 1 Given a variety of files and stock, the student selects the correct file and files a surface to specifications.
- T.O. 1 Given a variety of files, the student identifies each by appearance and function.
- T.O. 2 Given stock or metal to be filed and various files, the student associates the type or kind of file with the filing operation required.
- T.O. 3 Given a blueprint or specifications, stock or metal to be filed, and selected files, the student files the stock or metal according to a procedure (rough filing done first, then smooth filing) so that the material is filed to the smoothness and tolerance required by the specifications or blueprint.

Task 26. Operates saw filing machine.

- C.O. 1 Given a dull handsaw or band saw, and a saw filing machine, the student adjusts the saw filing machine and sharpens the saw to industrial standards.
- T.O. 1 Given a saw filing machine, the student identifies all its parts and their functions.
- T.O. 2 Given a band saw blade to be sharpened and a saw filing machine, the student makes all necessary adjustments to sharpen the blade.
- T.O. 3 Given a band saw blade to be sharpened and an adjusted saw filing machine, the student positions the blade on the machine, makes its final adjustments and sharpens the band saw blade. (The file must be at the proper angle during the sharpening operation.)

Task 27. Files circular saws.

- C.O. 1 Given a dull circular saw, file and a saw vise, the student will sharpen a circular saw to industrial requirements.

- T.O. 1 Given a saw vise, a circular saw to be sharpened, and appropriate file, the student sharpens the saw by filing the teeth to a specified angle, forming sharp cutting points at the tip of each tooth.

Task 28. Uses scale.

- C.O. 1 Given a blueprint and an architect's scale, the student identifies the scales on the rule and computes the scale on a drawing.

- T.O. 1 Given an architect's scale, the student identifies the different scales on the rule and states their applications.

- T.O. 2 Given several drawings and an architect's scale, the student uses the scale to compute the scale of the drawing and its dimensions to the nearest $1/32$ ".

Task 29. Operates the jointer.

- C.O. 1 Given a jointer and stock, the student makes the proper adjustments and planes the surface and edge of a piece of stock straight, flat and square.

- T.O. 1 Given a jointer, the student adjusts the cutting blade and planes one surface flat and true and one edge straight and square.

Task 30. Applies finish.

- C.O. 1 Given several types of finishing liquids, sandpaper, and types of stock, the student prepares the surface and applies the appropriate finish.

- T.O. 1 Given several kinds of finishing liquids, the student identifies them by name and states the application of each.

- T.O. 2 Given a job ready for sanding and sandpaper, the student selects the appropriate sandpaper and sands the job to a clean, smooth surface.

- T.O. 3 Given a surface ready for finish application, stain, fillers, selected finish, and applicator, the student applies stain to the job covering all surfaces, applies filler to the open grain to produce a nonporous surface, and finishes to a smooth, glassy surface.

Task 31. Cleans work area.

- C.O. 1 Given an untidy shop area and cleaning utensils, the student cleans the area to school standards.
 - T.O. 1 Given a shop area, the student identifies areas to be cleaned.
 - T.O. 2 Given an untidy shop and various cleaning utensils and materials, the student associates the cleaning utensils and cleaning materials with various cleaning operations.
 - T.O. 3 Given an untidy shop area and selected cleaning utensils and materials, the student cleans the area using appropriate procedures.

Task 32. Uses nail sets.

- C.O. 1 Given various sized nail sets, hammer, nails and stock, the student fastens stock with nails, setting the nails below the stock surface.
 - T.O. 1 Given various sizes of nail sets and nails, the student associates the sizes of the nail sets which are used with various sizes of nails.
 - T.O. 2 Given two pieces of stock nailed together, various nail sets, and a hammer, the student selects the appropriate nail set size and sets the nail or brad 1/32" below the surface of the stock.

Task 33. Uses the coping saw.

- C.O. 1 Given a variety of saws, marked stock, and saw blades, the student identifies the coping saw, inserts the blade and cuts to a line.
 - T.O. 1 Given a variety of saws, the student identifies the coping saw by its appearance and function.
 - T.O. 2 Given a coping saw and various blades, the student identifies the appropriate blade for the saw by the type of cut required.
 - T.O. 3 Given a coping saw and a selected blade, the student installs the blade into the saw frame (with teeth pointing away from the handle).
 - T.O. 4 Given a coping saw with the blade installed and a piece of worked stock, the student cuts the stock to the markings without bending or breaking the blade.

Task 34. Uses the knife.

- C.O. 1 Given a blueprint, knife, prepared lumber and sharpening equipment, the student sharpens the knife, lays out lines across the grain and whittles a surface to shape.
- T.O. 1 Given a knife, the student identifies its functions.
- T.O. 2 Given a knife, layout board, blueprint or sketch, and layout tools, the student draws all lines crossing the grain to required specifications.
- T.O. 3 Given a knife and a piece of scrap stock, the student identifies the sharpness of the knife by cutting shavings from the stock observing the smoothness of the cut and noting the resistance of the cut.
- T.O. 4 Given a dull knife, grinder, oil stone, and a strop, the student sharpens the knife by grinding the blade to form two concave edges without burning the blade and then by whetting on an oil stone and stropping the knife to a razor-like edge so that it will cut a piece of paper.
- T.O. 5 Given a sharp knife and a piece of marked stock, the student uses the knife to whittle the stock to the shape of markings or template.

Task 35. Uses the mallet.

- C.O. 1 Given a variety of mallets, the student selects the appropriate mallet to be used for chiseling, gouging, and mounting stock on a lathe.
- T.O. 1 Given wooden, fiber, and rubber mallets, the student identifies each by its appearance and use.
- T.O. 2 Given a job requiring chiseling or between center turning on a lathe, and a tail center, the student associates the proper mallet required with each operation.
- T.O. 3 Given a piece of stock requiring chiseling, a chisel and a selected mallet, the student demonstrates the proper use of the mallet with the chisel.
- T.O. 4 Given a piece of stock to be turned, a lathe, and a selected mallet, the student demonstrates the proper use of the mallet and centering the tail center.

Task 36. Uses the hand drill.

- C.O. 1 Given a variety of hand drills, bits, and prepared lumber, the student states the difference between hand drills by their size and appearance, inserts a drill bit, and drills a straight hole in lumber.
- T.O. 1 Given a hand drill and a breast drill, the student differentiates between the two by appearance and application.
- T.O. 2 Given a hand drill, a breast drill, and drill bits, the student inserts the bits into the chuck and tightens the chuck making sure the drill bit is straight and tight.
- T.O. 3 Given a piece of marked stock and a hand drill with the bit installed, the student positions the bit on the center mark and drills the hole in the stock keeping the bit straight by turning the hand drill slowly when drilling and removing the bit.

Task 37. Selects drill bits.

- C.O. 1 Given an assortment of twist drills, metal stock, and a portable electric drill, the student inserts the correct bit into the drill and drills a hole in metal to specifications.
- T.O. 1 Given a selection of drill bits, the student identifies each by name, appearance, size, and application.
- T.O. 2 Given a piece of marked metal stock 1/8" thick, a hand drill, and an assortment of bits, the student selects the most appropriate bit to drill the hole at the center point.

Task 38. Uses push drill.

- C.O. 1 Given a variety of hand drills, push drill, bits and stock, the student identifies the push drill by its shape and size, inserts a bit and push drills a hole for a specified fastener.
- T.O. 1 Given various hand drills, the student differentiates the push drill from the others by its appearance and function.
- T.O. 2 Given a push drill with a selected drill bit and hardware located on a cabinet frame, the student uses the push drill to drill a screw hole straight and in the center of the hole located on the hardware.

Task 39. Sharpens drill bits.

- C.O. 1 Given a drill, drill bit, grinder, and drill grinding jig, the student sharpens the drill to industrial standards using a grinding jig.

- T.O. 1 Given an assortment of sharp and dull drill bits, the student differentiates the sharp drill from the dull drill by its appearance and feel.
- T.O. 2 Given a grinder, a drill grinding jig, and a dull drill, the student grinds the drill at the proper angle and sharpness without burning it.

Task 40. Uses clamps.

- C.O. 1 Given prepared stock, glue, and a selection of clamps, the student will glue the stock to required length or thickness using appropriate clamps and clamping procedures.
- T.O. 1 Given various clamps, the student identifies each by appearance and function.
- T.O. 2 Given stock to be glued and various clamps, the student associates the type of clamp with the clamping requirements of the job.
- T.O. 3 Given glued stock and selected clamps, the student clamps the stock so that all the joints are tight with equally distributed pressure. (Clamps must be placed alternately.) When using clamps on finished work, filler pieces must be used between the clamps so that the stock will not be damaged.

Task 41. Uses glue scrapers.

- C.O. 1 Given a selection of scrapers and glued stock, the student selects the appropriate glue scraper for the job to be done and scrapes all hardened glue from a wood joint.
- T.O. 1 Given several scrapers, the student identifies the glue scraper by its appearance and its functions.
- T.O. 2 Given a block of glued stock on which the glue has hardened and several scrapers, the student selects the glue scraper and scrapes off all traces of hardened glue so that the stock is clean of all glue particles.

Task 42. Uses the scratch awl.

- C.O. 1 Given a selection of layout tools, blueprint, stock, and layout fluid, the student selects the scratch awl and makes a layout on metal to within 1/64 of specified dimensions.
- T.O. 1 Given a selection of layout tools, the student identifies the scratch awl by its appearance and states its functions.

- T.O. 2 Given a blueprint, Prussian Blue layout fluid, layout tools, and metal stock, the student selects the scratch awl and lays out specifications from the drawing onto the metal stock to the nearest 1/64" (applies Prussian Blue to surface area of stock before laying out).

Task 43. Uses wood scraper.

- C.O. 1 Given a selection of scraping tools, mill file, burnishing tool, and prepared stock, the student selects the appropriate scraper for the task, sharpens the scraper and smooths a surface.
- T.O. 1 Given a selection of scraping tools, the student identifies the wood scraper by its appearance and states its functions.
- T.O. 2 Given a mill file and a burnishing tool, the student selects the wood scraper, files the blade edge at right angles to the surfaces (forming a slightly convex edge), and then, using the burnishing tool, burnishes or curls the edge of the blade to form a slightly curled lip on the cutting edges.
- T.O. 3 Given a piece of machine-milled stock and a sharp wood scraper, the student scrapes the machine marks from the stock by drawing the blade toward the user at an angle as to peel a small shaving from the surface of the stock.

Task 44. Uses the burnishing tool.

- C.O. 1 Given a burnishing tool and a ground scraper blade, the student forms a cutting edge on the blade.
- T.O. 1 Given a selection of tools, the student identifies it by its appearance and states its functions.
- T.O. 2 Given a dull wood scraper and a burnisher, the student selects the burnishing tool and draws or forms a cutting lip to the cutting edge of the scraper.

Task 45. Mills stock.

- C.O. 1 Given a variety of woodmilling machines and stock, the student establishes the working surfaces and mills the stock to size using appropriate machine for each task.
- T.O. 1 Given a list of dimensions, a cut-off saw, band saw, jointer, a thickness planer, and a circular saw, the student associates the use of each machine as to its function in milling stock to dimensions by stating the procedure in milling a stock to dimensions.

- T.O. 2 Given various wood milling machines, a piece of rough stock to be milled on one surface, and one edge long enough to be milled on a machine, the student selects the appropriate machine and mills one surface straight and flat and one edge straight and at a right angle to the surface.
- T.O. 3 Given a piece of stock, which has been milled on one side and one edge, and various wood milling machines, the student selects the appropriate one for milling and planes the stock to required thickness.
- T.O. 4 Given a piece of stock which has been milled to thickness and having one edge straight and square, the student selects the appropriate machine and squares one end straight and square and cuts the piece to the required length.

Task 46. Operates the thickness or surface planer.

- C.O. 1 Given a blueprint, thickness planer, grinding attachment, and stock, the student checks the sharpness of the blades and grinds, if necessary, adjusts the machine and planes the stock to within $1/32''$ of required thickness.
 - T.O. 1 Given a thickness planer, the student identifies the machine, its function, its parts, and their functions.
 - T.O. 2 Given a thickness planer, the student identifies appropriate procedures for eliminating dangers by stating precautions.
 - T.O. 3 Given dimensions, a thickness planer, and a piece of stock long enough to go through the machine, the student makes the necessary adjustments and planes the stock to the nearest $1/32''$ in thickness.
 - T.O. 4 Given a thickness planer with a blade sharpening attachment, the student associates the sharpener parts with their functions.
 - T.O. 5 Given a thickness planer with dull blades and a grinding attachment, the student operates the grinding attachment and sharpens the blades so that they will have a sharp, keen edge.

Task 47. Works to the nearest $1/32''$.

- C.O. 1 Given a blueprint, measuring instruments, and wood shaping tools and equipment, the student shapes the object to within $1/32''$ of specified dimensions.
 - T.O. 1 Given a scale or rule, the student identifies the $1/32''$ markings by counting or observations.

Task 51. Arranges assembly sequence.

C.O. 1 Given a blueprint and prepared members of a job, the student arranges and orders stock for assembly.

T.O. 1 Given a blueprint or sketch, the student analyzes the drawing and identifies methods of constructing and assembling the job.

T.O. 2 Given a blueprint or sketch and methods of constructing an assembly, the student selects the most appropriate way to construct and assemble the job in a sequence in the least amount of time.

Task 52. Computes areas.

C.O. 1 Given a surface area and formulae, the student computes the area contained on the surface.

T.O. 1 Given length and width dimensions of a surface and a formula for computing areas of various geometric shapes, the student performs the arithmetic computations to find the area to the nearest square inch.

Task 53. Uses adhesive tools.

C.O. 1 Given a variety of adhesives and adhesive tools, the student selects the correct adhesive and tools for the job and applies glue to required surfaces.

T.O. 1 Given a variety of adhesive tools, the student identifies each by appearance and function.

T.O. 2 Given various types of adhesives, the student identifies their application and associates the tools used with them.

T.O. 3 Given a job requiring the use of an adhesive and tools for application, the student selects the appropriate adhesive and identifies the procedure for completing the job.

T.O. 4 Given a job requiring the use of adhesive tools and adhesives, the student performs the procedures to complete the job. (The surface areas must be clean and the material must be cemented firmly.)

Task 54. Operates the power router (portable).

C.O. 1 Given a power router, router bits, and stock, the student selects and installs the bit for required shape and cuts the specified edges or surfaces.

- T.O. 1 Given a portable power router, the student identifies all of its parts and their functions.
- T.O. 2 Given a portable router, the student identifies the operation of the router.
- T.O. 3 Given a selection of router bits, the student associates the types of cuts with the bits.
- T.O. 4 Given a job requiring the use of a router and various router bits, the student selects and installs the proper bit and makes the necessary cuts.

Task 55. Uses gouges.

- C.O. 1 Given a variety of gouges, sharp and dull, sharpening equipment, and prepared stock, the student sharpens the dull gouges and shapes the stock to size.
 - T.O. 1 Given various types of gouges, the student identifies each by its name, sweep, appearance, size, and function.
 - T.O. 2 Given a cluster of sharp and dull gouges, the student identifies the dull gouges by using them to cut cross grain on a piece of scrap stock and noticing that the cut is not smooth and/or the gouge has great resistance to being pushed across the grain.
 - T.O. 3 Given a bench grinder with a round faced wheel and buffer, and a slip stone, the student grinds the gouge to a sharp edge without burning the edge, uses the slip stone to produce a fine cutting edge, and then buffs the gouge to form a razor-sharp edge to produce a fine smooth cut when cutting across the grain of a piece of sugar pine.
 - T.O. 4 Given a job layed out requiring the use of gouges, and a selection of sharp gouges, the student selects the most appropriate gouge and pares the excessive stock to the line so that the contour is straight and smooth.

Task 56. Uses the spoke shave.

- C.O. 1 Given various spoke shaves, the student identifies the boxwood and metal framed spokeshave, adjusts either one selected and shapes an object to size.
 - T.O. 1 Given various types of spoke shaves (wood and metal frame), the student differentiates between them by their appearance and function.
 - T.O. 2 Given a boxwood spoke shave and a metal spoke shave, the student identifies their parts and their functions.

- T.O. 3 Given a spoke shave, the student adjusts the cutting blade to produce the desired shaving by trying it on a piece of scrap wood. (The shavings produced should be fine and smooth.)
- T.O. 4 Given a template, layed out stock, and a sharp spoke shave, the student uses the spoke shave to shave the stock to the shape layed out and to the template.

Task 57. Operates the drill press.

- C.O. Given a drill press, bits, and marked stock, the student adjusts the machine speed, adjusts depth of cut, installs the bit, and drills a hole to within 1/32" between centers.
 - T.O. 1 Given a drill press, the student identifies its parts by their appearance and their functions.
 - T.O. 2 Given a drill press, the student identifies the operating and safety procedures associated with the drill press.
 - T.O. 3 Given a piece of marked stock to be drilled, drill press, and drill bit, the student positions the stock on the table and drills the required holes in the stock.

Task 58. Operates the lathe.

- C.O. Given a wood lathe, blueprint, and turning tools, the student turns stock to specified size and shape.
 - T.O. 1 Given a selection of lathes, the student identifies each by its type and size.
 - T.O. 2 Given a selection of lathes, the student identifies their parts and attachments and states their functions.
 - T.O. 3 Given a lathe, the student identifies the operating and safety procedures for using a lathe.
 - T.O. 4 Given a piece of stock, a blueprint, and turning tools, the student shapes the stock to the dimensions specified on the blueprint.

Task 59. Uses shapers and cutters.

- C.O. 1 Given a shaper, shaper cutters, and the specified contour, the student selects the required contour cutter, mounts it on the machine, and cuts the specified contours.
 - T.O. 1 Given a shaper, the student identifies its parts by their appearance and functions.

- T.O. 2 Given a selection of cutting blades used in a shaper, the student associates the blades with the type of cuts they make.
- T.O. 3 Given a shaper and a cutter, the student identifies the operation and the safety procedures of the shaper, including the installation of cutting blades.
- T.O. 4 Given a piece of stock and a blueprint, the student selects and installs the appropriate cutter for the desired cut.
- T.O. 5 Given a piece of stock, blueprint, and a set-up shaper, the student makes the necessary cuts specified on the blueprint.

Task 60. Uses the jig saw.

- C.O. 1 Given a jig saw, prepared stock, and blades, the student inserts the blade and stock on the machine, and cuts to the contour line.
 - T.O. 1 Given a jig saw, the student identifies its parts and states their functions.
 - T.O. 2 Given a jig saw and blade, the student identifies the operation and safety procedures for the jig saw.
 - T.O. 3 Given a piece of marked stock and a jig saw, the student operates the saw and cuts the stock to marked outline.

Task 61. Uses snip shears.

- C.O. 1 Given a variety of shears and prepared stock, the student selects the correct shears for the job to be done and cuts the sheet metal stock to the contour marked.
 - T.O. 1 Given a variety of shears, the student identifies the snip shears by appearance and function.
 - T.O. 2 Given a pair of snip shears, the student identifies their procedure of operation.
 - T.O. 3 Given a pair of snip shears and flashing material marked to size and shape, the student cuts the material to desired dimensions developing a smooth cut.

Task 62. Mixes plasters and plastics.

- C.O. 1 Given a selection of plasters and plastics, the student differentiates between them by their appearance and characteristics, and mixes each according to product directions.

- T.O. 1 Given a selection of plasters and plastics, the student differentiates them by their characteristics.
- T.O. 2 Given a selection of plasters and plastics, the student associates the ingredients and the procedures for mixing each.
- T.O. 3 Given selected plastics or plasters, water, epoxy, and hardeners, the student mixes the plastics or plasters to a creamy consistence (having no lumps or air bubbles).

Task 63. Operates the tenoner.

- C.O. 1 Given a tenoner and layed out stock, the student adjusts the machine for the desired cut and cuts a tenon.
 - T.O. 1 Given a tenoner, the student identifies the parts of the machine and their functions.
 - T.O. 2 Given a tenoner, the student identifies the adjustment and operating procedure of the machine.
 - T.O. 3 Given a tenoner, a piece of stock, and blueprint specifications, the student adjusts the cutting depth and makes the cut to desired dimensions.

Task 64. Uses the drawknife.

- C.O. 1 Given a drawknife and square stock to be turned on a lathe, the student cuts off the square corners to eliminate extra turning.
 - T.O. 1 Given a drawknife, the student identifies its functions and how it is used.
 - T.O. 2 Given a piece of stock which is to be rounded, the student removes excess stock with a drawknife. (Only rough cutting is required.)

Task 65. Makes joints.

- C.O. 1 Given a job requiring various kinds of joinery, the student completes the construction using the specified joints.
 - T.O. 1 Given several types of joinery, the student identifies each by its appearance and application.
 - T.O. 2 Given woodworking tools, machinery, and a job requiring joints, the student makes the following joints: butt, dado, rabbit, lap, mortise, tenon, miter, tongue and groove to a fit snug by industrial standards.

APPENDIX E

Learner Activity Guide
and Performance Evaluation Set:
Sample Modules

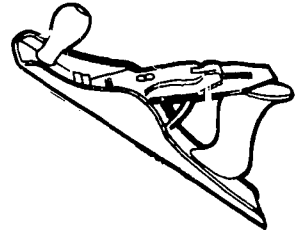
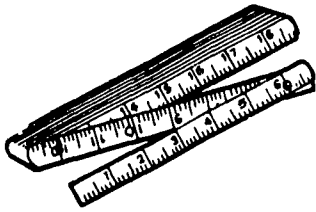

PERFORMANCE EVALUATION SET & LEARNER ACTIVITY GUIDE

CORE WOODWORKING PROGRAM

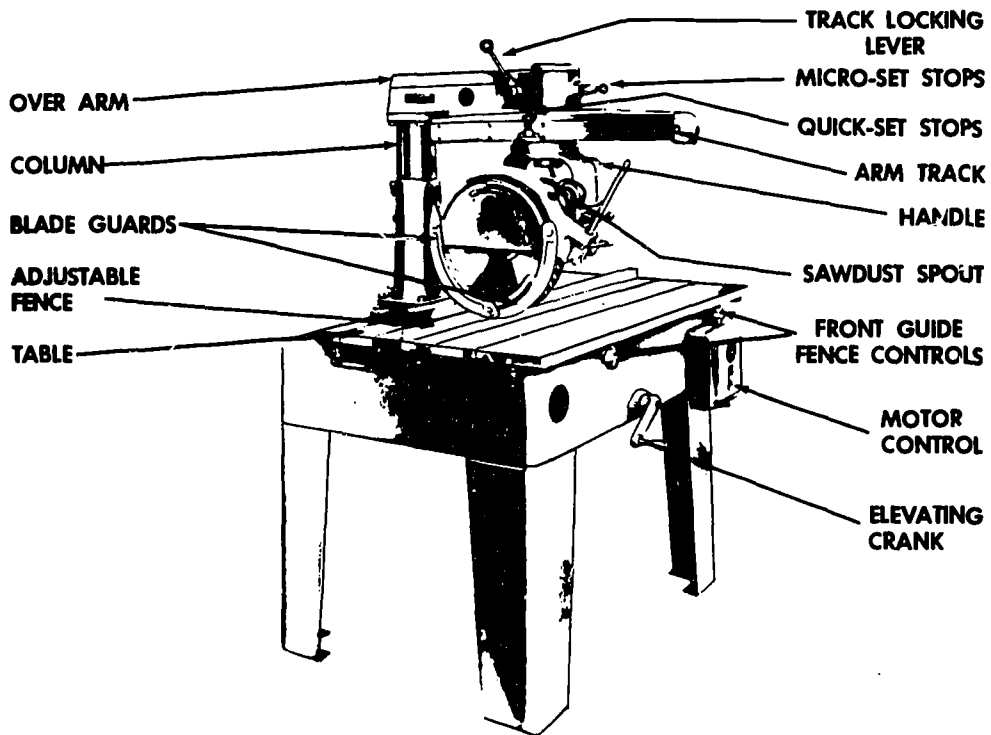

5-2 RADIAL SAW OPERATION

PERFORMANCE EVALUATION SET
& LEARNER ACTIVITY GUIDE

OPS/AIR/ABLE
GENERAL
WOODWORKING
LEVEL I

RADIAL SAW OPERATION
PE 5-2

TASK	C. O.	T. O.
45	1	1

NAME _____
DATE _____

LEARNER ACTIVITY GUIDE

PREREQUISITES: PE 1-1.

OBJECTIVES: Given a radial saw, rough stock and dimensions, you will:

1. Identify the parts of the saw and state the function of each.
2. Cut stock to rough length.

COMMENTS: Because the radial saw can be used for so many cutting purposes, you should know the names of the important parts of the machine and their function.

STUDENT-INSTRUCTOR CONTRACT OPTIONS:

- 1. Student-instructor conference.
- 2. Steps on back of drawing KD-4.
- 3. Read text Technical Woodworking, pages 158-163.
- 4. Other--Specify _____.

EQUIPMENT, TOOLS, MATERIALS: Radial saw and rough stock.

Copyright applied for - All rights reserved - Project ABLE
(Limited copyright protection for materials developed under
grants and contracts from the U.S.O.E.)

QPS/AIR/ABLE
GENERAL
WOODWORKING
LEVEL I

RADIAL SAW OPERATION
PE 5-2

TASK	C. O.	T. O.
45	1	1

NAME _____
DATE _____

PERFORMANCE ACTIVITY KNOWLEDGE
(Pre and/or Post Assessment)

NOTE: Use response card T-T #Z-11 for answering questions below.
The correct answer is H.

Given a radial saw, rough stock and dimensions, you will:

Step A. Identify the parts of a radial saw and state their function.

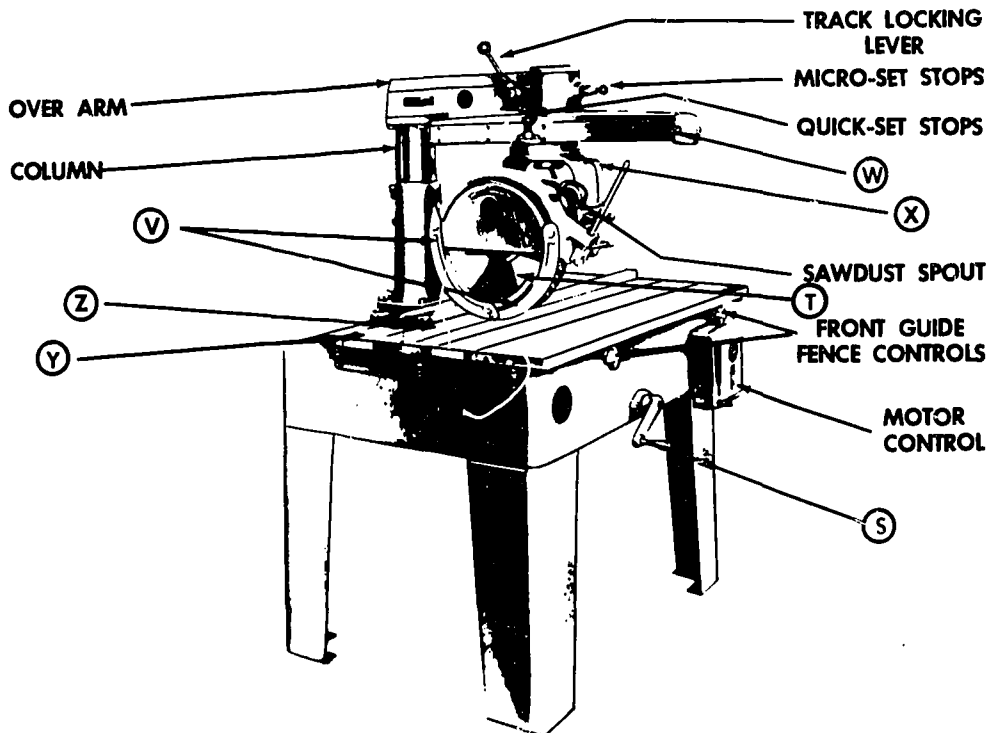

1. The part of the radial saw which supports stock when it is being cut is
 - c. Z
 - d. Y

2. When stock is being cut to length it is held hard against
 - a. X
 - b. Y
3. The motor and blade is fastened to the
 - a. X
 - b. W
4. The motor and blade ride on
 - b. W
 - c. X
5. On some radial saws, the radial arm is also called
 - c. Overarm
 - d. Yoke
6. The saw is raised and lowered by
 - c. Z
 - d. S
7. The item which protects the operator from the saw blade is
 - c. T
 - d. V
8. When the radial saw is used for cutting stock to length, it is best to use a small toothed saw for the
 - a. V
 - b. T

Step B. Cut stock to rough length.

9. In a basic woodworking shop, the radial saw is primarily used for
 - a. ripping.
 - b. planing.
 - c. rabbeting.
 - d. crosscutting.

10. When making adjustments on a radial saw, the most important thing to do is
 - a. shut off the power.
 - b. clean the floor area.
 - c. clean off the table.
 - d. wear safety glasses.

11. Waste particles and sawdust on the table are useful for supporting a twisted piece of stock when cutting it to length.
 - c. False
 - d. True

12. The depth of the saw should be set to cut about $1/8$ " below the surface of the table.
 - a. True
 - b. False

13. When cutting several pieces of stock to the same length it is best to nail a wood stop at the desired length on the table.
 - c. True
 - d. False

14. When cutting stock that is cupped, the cupped surface must be up on the table.
 - c. True
 - d. False

15. You can be sure of cutting close to the desired length if the saw is pulled up to your mark before starting.
 - a. True
 - b. False

16. When cutting stock on a radial saw, it is wise not to pull the saw too rapidly because you might jam the blade to the stock.
 - c. False
 - d. True

17. The function of the fence is to
 - a. support the table.
 - b. keep scraps of stock from the blade.
 - c. provide backing for stock.
 - d. provide a setting for length.

18. The part on the radial saw which can be moved on the track arm and holds the arbor and blades is the
- a. yoke.
 - b. over arm.
 - c. guide fence.
 - d. motor.
19. The part which allows the yoke to move forward and backward is called the
- a. over arm.
 - b. track arm.
 - c. fence.
 - d. base.

NOTE: Now use the saw to do the work specified by your instructor.

OPS/AIR/ABLE
GENERAL
WOODWORKING
LEVEL I

RADIAL SAW OPERATION
PE 5-2

TASK	C. O.	T. O.
45	1	1

NAME _____
DATE _____
MAN-HOURS _____
INSTRUCTOR _____

CRITERION CHECKLIST

L M S

Identify the parts of a radial saw and state their function.

U S

1. Locates the following parts and states their function.
 - a. Table
 - b. Guide Fence
 - c. Yoke
 - d. Track Arm
 - e. Radial Arm
 - f. Blade Guard
 - g. Saw Blade
 - h. Elevating Crank

L M S

Cut stock to rough length.

U S

1. Clears table of waste particles and checks depth setting of blade.
2. Measures and marks length of piece to be cut.
3. Places stock cup side down against the fence.
4. Cuts stock to marked length.

SAMPLE

TOOLS AND MACHINES TO USE

JOINTER - THICKNESS PLANNER - DRILL PRESS - DRILL - DISC SANDER - SCREWS
 SCREWDRIVER - COUNTERSINK - SQUARE - MARKING GAGE - T BEVEL - RULE
 KNIFE - STRAIGHTEDGE - CIRCULAR SAW - DIVIDERS - MACHINE BIT - WIRE - GAGE
 RADIAL SAW

ACTIVITIES

DRESSING LUMBER - USING POWERTOOLS - CHAMFERING - LAYING OUT - BORING
 DRILLING - COUNTERSINKING - FASTENING WITH WOOD SCREWS - SPACING ON
 DIAMETERS - BLUEPRINT READING - SCREW SHANK CLEARANCE HOLES

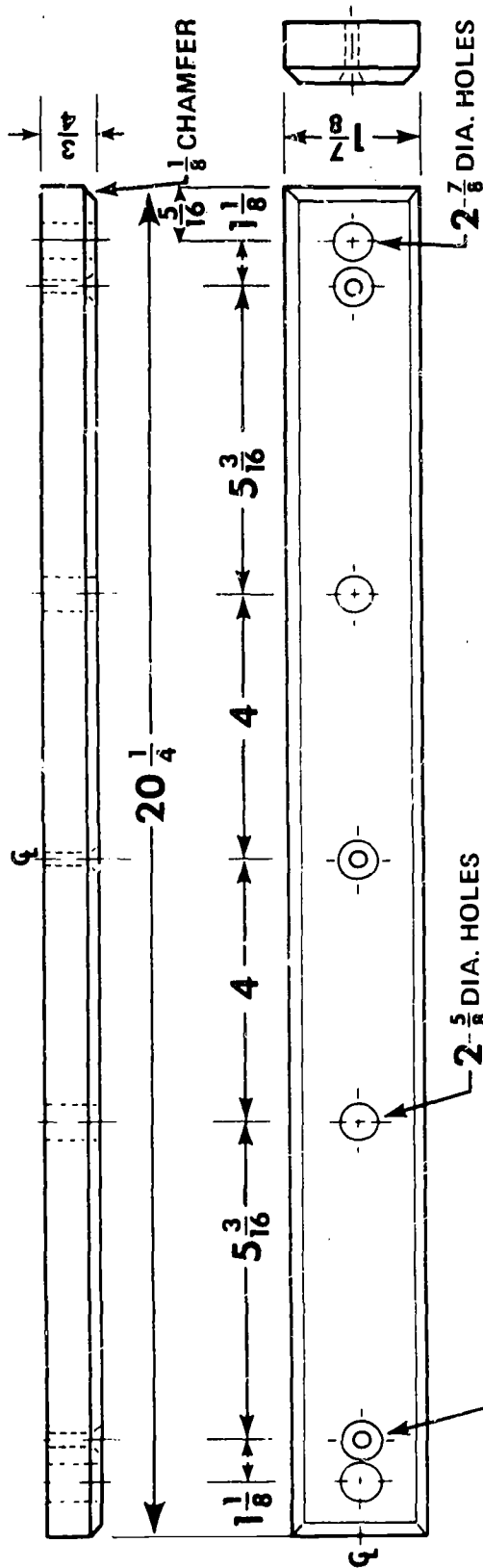

3 - HOLES DRILLED AND COUNTERSUNK FOR $1 \frac{1}{2}$ - NO. 10 F. H. SCREWS

KIND OF WOOD SPECIFIED BY INSTRUCTOR

QUINCY VOC TECH GEN WOOD DEPT	KNEEHOLE DESK LEG CLEAT	DWN BY FL. P.T.	QUANT 1	SCALE	DATE 6-69	PART NO. 31	DWG NO. KD-4	MAT'L TO SUIT	REV. 2-70
----------------------------------	----------------------------	--------------------	------------	-------	--------------	----------------	-----------------	------------------	--------------

RADIAL SAW OPERATION FOR
COMPONENT CONSTRUCTION OF KNEEHOLE DESK (DWG KD-4)
OR FOR TASK OF EQUIVALENT DIFFICULTY

- Step 1. Have your instructor assign you to a radial saw and then shut off the power at the power panel.
2. Use a long stick or bench brush and clean all scraps of wood from the table top and the floor area.
3. Check the table of the saw assigned you. It should be kept clean, flat, and true at all times. Check to see if it is square with the blade.
4. Look for the guide fence inserted into the table. Check to see if it is straight or damaged. Be sure that it is not scored or charred or has saw cuts, cracks, or breaks. If any of these conditions exist, the fence is to be replaced. The fence must also be square with the travel of the saw. Check it with a framing square held against the fence.
5. Find the base of the saw. It must be set level to prevent twisting or misalignment to the machine.
6. Locate the yoke. The yoke can be turned 360 degrees but is normally moved only 180 degrees. The blade and motor unit on the yoke can be tilted 90 degrees to the left or right. Set the yoke so that a 30 degree cut can be made on a board at a 90 degree angle.

STOP _____ INSTRUCTOR CHECK
initials

7. Locate the track arm which enables the yoke to move forward or backward. It is commonly adjustable to any degree within 180 degrees to the left or right. Loosen the mitre clamp handle and set the track arm so that a 45 degree cut can be made. Be sure to tighten the clamp after it is set.

STOP _____ INSTRUCTOR CHECK
initials

8. Get a piece of rough stock and cut it to 20 7/8" long for drawing KD-4, or cut one specified by your instructor.

APPENDIX F

TIME REQUIRED TO COMPLETE
LEARNING AND PERFORMANCE ASSESSMENT ACTIVITIES

Time Required to Complete
Learning and Performance Assessment Activities

<u>Module No.</u>	<u>Activity</u>	<u>Time Hr:Min</u>
1-1	General Shop Safety	3:30
2-1	Blueprint Component Identification	5:00
2-2	Isometric Sketching	7:30
2-3	Blueprint Interpretation	7:30
3-1	Use of Handtools for Component Construction	12:30
4-1	Bandsaw Operation	1:40
4-2	Jointer Operation	5:20
4-3	Thickness Planer Operation	3:20
4-4	Disc Sander Operation	1:40
5-1	Use of Handboring Tools	5:20
5-2	Radial Saw Operation	3:20
5-3	Circular Saw Operation	6:40
5-4	Drill Press Operation	5:20
5-5	Use of Abrasive Papers	2:30
6-1	Stock List Construction	2:30
6-2	Joinery & Frame Assembly	12:30
6-3	Advanced Frame Assembly	10:00
6-4	Joinery & Gluing	10:00
6-5	Joinery & Layout	12:30
6-6	Leg and Rail Construction	5:50
6-7	Joinery & Milling Operations	3:20
6-8	Joinery & Milling Operations	7:30
6-9	Rail & Apron Construction	6:40
6-10	Drawer Front Construction	12:30
6-11	Joinery & Routing	12:30
6-12	Panel Cutting	2:30
7-1	Lathe Operation	10:00
7-2	Lathe Operation (Short Work)	10:00
7-3	Lathe Operation (Long Work)	12:30
7-4	Crosslap Joinery	5:00
7-5	Fine Detail Lathe Work	12:30

<u>Module No.</u>	<u>Activity</u>	<u>Time Hr:Min</u>
7-6	Lathe Turning (Faceplate)	12:30
7-7	Special Component Construction	11:40
7-8	Major Assembly	10:50
7-9	Hardware Application	5:00
7-10	Stain Finishing	10:50
7-11	Final Finishing	12:30

Average time required to complete performance assessment certification by experienced students with a minimum of instruction and practice TOTAL 133 Hours

Average time required to complete all learning and performance assessment activities for the majority of general woodworking students at the 10th grade level TOTAL 266 Hours

Average time required to complete learning and performance assessment for those students experiencing reading problems or other difficulties TOTAL 400 Hours

APPENDIX G

Recommended Equipment, Tools,
Supplies, and Training Aids

Wood Milling Equipment

<u>ITEM</u>	<u>ESTIMATED CCST</u>
Bandsaw 14"	\$ 300.00
Spindle sander	480.00
Desk sander 12"	250.00
Drill press 15"	300.00
2 lathes 48"	1,000.00
Jointer 8"	300.00
Circular saw 10"	540.00
Jig saw	240.00
Mortising attachment	150.00
Saw filer	300.00
Grinder	110.00
Thickness planer	700.00
Portable 1/4 drill and portable router	255.00
Estimated TOTAL:	<u>\$4,925.00</u>

Student Tool Kits

(Recommended for highest productivity potential)

<u>ITEM</u>	<u>ESTIMATED COST</u>
1-smooth plane	10.25
1-1" flat sweep paring gouge	8.35
1-1/2" medium sweep paring gouge	6.90
1-1/4" full sweep paring gouge	6.50
1-1" outside ground gouge (flat sweep)	4.30
1-1/2" outside ground gouge (medium sweep)	4.60
1-1/4" outside ground gouge (full sweep)	5.85
1-1/16 nail set	.50
1-10" try square	3.85
1-6" marking gauge	1.35
1-sloyd knife	1.65
1-6" OD calipers	2.35
1-6" divider	2.35
1-13 oz. hammer	3.55
1-screwdriver	2.00
1-woodworker's vise	23.10
1-zig zag rule	2.50
1-1/4" paring chisel	3.35
1-1/2" paring chisel	3.65
1-1" paring chisel	3.85
Cost per individual student kit:	<u>\$101.00</u>

Central Tool Crib

<u>ITEM</u>	<u>ESTIMATED COST</u>
1-rabbit plane	9.50
1-flexible bottom plane	15.00
2-jointer planes	40.20
2-jack planes	23.00
6-block planes	28.00
2-combination squares	8.50
2-framing squares	13.00
1-24" level	5.25
1-1/2" full sweep gouge	6.90
1-1/4" medium sweep gouge	6.50
1-1" butt chisel	2.00
1-1/2" butt chisel	1.75
1-1/4" butt chisel	1.50
2-hand drills	10.00
1-6" universal wrench	3.00
1-burnishing tool	2.10
2-scribes	3.00
1-set of carving tools	13.50
12-wood files	24.00
6-bit braces	48.00
6-countersinks	12.00
6-screwdriver bits	6.00
1-auger bit set	20.20
1-set forstner bits	70.00
1-set twist drills	32.00
2-push drills	16.00
6-router bits assortment	18.00
1-8" oilstone (India combination)	3.40
1-6" slip stone, medium	2.60
6-awls	9.00
3-Phillips screwdrivers	3.00
2-sets of drawing instruments	30.00
2-pairs of pliers	3.00
1-embossing machine	8.75
1-miter box	85.00
1-set trammels	12.00
1-set of socket wrenches	35.00
1-set of open end wrenches	20.00
1-wheel dresser	3.50
1-8" draw knife	5.20
3-back saws	18.00
6-6" T-bevels	15.00
1-wire gauge	6.00
6-I.D calipers	14.35
2-file cards	3.00
1-oil can	1.50
1-pinch bar	3.00
1-set dado blades	28.00
3-circular saw blades--cross, rip and combination	15.00

1-expansion bit	4.15
2-wooden mallets	4.00
2-coping saws	6.00
24-pinch dogs	24.00
2-lathe tool sets	23.00
24-bar clamps	96.00
12-6" C clamps	48.00
12-6" hand screws	84.00
12-2" spring clamps	8.40
1-nest of keyhole saw	5.75
1-hacksaw	1.70
2-handsaws--rip and crosscut	20.00
6-glue scrapers	9.00
6-wood scrapers	30.00
1-panel gauge	6.00
1-prick punch	.90
2-hand routers	30.00
2-hollow chisels-- 1/4 and 5/16	16.30
2-chisel bits--1/4 and 5/16	8.10
2-putty knives	2.60
1-5/8" plug cutter	1.90
Estimated TOTAL:	<u>\$1,193.00</u>

Training Aids

27 models for blueprint drawing sketch interpretation
 Types of lumber cuts
 Defects in lumber
 Hardware identification
 Plywood identification
 Wood identification
 Abrasive papers
 Gluing techniques
 Construction Techniques
 Angle block pattern

Also, knockdown parts and samples of jobs typical of work performed at the first level of training.

Suggested 8MM Loop Films

Woodworking 8MM Loop Films (Super eight) McGraw Hill
Publishing Company, May 15, 1969. (Cost given at \$20.
each or \$680. per set.)

<u>ITEM</u>	<u>ORDER NUMBER</u>
The Compass Saw	698717
Drilling	689718
Boring with an Auger Bit	698719
Boring with the Forstner Bit	698720
Setting a Plane	698721
Planing a Chamfer	698722
Methods of Planing End Grain	698723
Squaring Up Stock	698724
Filing Wood	698725
Scraping Wood	698726
Using Spoke Shoves	698727
Using a Gouge	698728
Chiseling to a Finished Line	698729
Gluing Edge to Edge	698730
Grinding a Chisel	698743
Whetting a Chisel	698744
Sharpening a Handscraper	698741
Cutting a Dado	698738
Gluing and Fastening a Mitre Joint with a Spline	698737
Gluing a Dowel Joint	698734
Wood Terminology and Measurement	698702
Combination Square and Its Use	698703
Using the Marking Gauge	698704
Driving and Setting Nails	698706
Laying Out Corner Radii	698705
Drawing Nails	698707
Methods of Driving Screws	698708
Dilling Anchor Holes, Clearance Holes and Countersinking	698709
Using Handscrews	698710
Smoothing with Abrasive Paper	698711
Using a Crosscut Saw	698712
The Hacksaw	698713
Coping Saw	698714
Coping Saw for Thin Material	698715