

## ERIC REPORT RESUME

ERIC ACC. NO. ED 043 790		IS DOCUMENT COPYRIGHTED? YES <input type="checkbox"/> NO <input checked="" type="checkbox"/>	
CH ACC. NO. AA 000 625	P.A. 48	PUBL. DATE Aug 70	ISSUE RIEMAR71
		ERIC REPRODUCTION RELEASE? YES <input type="checkbox"/> NO <input checked="" type="checkbox"/>	
		LEVEL OF AVAILABILITY I <input checked="" type="checkbox"/> II <input type="checkbox"/> III <input type="checkbox"/>	
AUTHOR Furey, Mary Z.			
TITLE Multi-Media Economic Analysis Project: Final Evaluation Report.			
SOURCE CODE BBB02043	INSTITUTION (SOURCE) Sterling Inst., Wash., D.C.		
SP. AG. CODE BBB02778	SPONSORING AGENCY DHEW, Nat'l Ctr. for Educ Res & Dev.		
EDRS PRICE 0.75;7.65	CONTRACT NO.		GRANT NO.
REPORT NO.	BUREAU NO. BR-8-0447		
AVAILABILITY			
JOURNAL CITATION			
DESCRIPTIVE NOTE 151p.			
DESCRIPTORS *Course Evaluation; *Media Research; *Military Schools; *Academic Achievement; *Economics			
IDENTIFIERS			
ABSTRACT This report presents the findings obtained in evaluating several important aspects of the Multi-Media Economic Analysis Course as it was presented in the United States Naval Academy during the evaluation semester (Fall 1969-70). This course was presented to 39 randomly selected third class (sophomore) and second class (junior) Midshipmen who had not previously had any economics courses. In the course, the students proceeded at their own pace and exercised options in the selection of media and enrichment, and thus maintained a significant degree of control over when and how they studied. The following aspects of the course were evaluated: (1) student performance, (2) student and instructor acceptance, (3) course management, and (4) general operational environment. A summary and two appendices are included. (CK)			

ED 043 790

8,0447  
PA 48

FINAL EVALUATION REPORT  
MULTI-MEDIA ECONOMIC ANALYSIS PROJECT

Educational Technology Center  
of Sterling Institute, Inc.  
2600 Virginia Avenue, N.W.  
Washington, D.C. 20037

August 1970

1 000 625

**FINAL EVALUATION REPORT**

**Contract No. N00600-68-750**

**Mary Z. Furey  
Educational Technology Center  
of Sterling Institute, Inc.  
2600 Virginia Avenue, N.W.  
Washington, D.C. 20037**

**August 1970**

**U.S. DEPARTMENT OF  
HEALTH, EDUCATION, AND WELFARE**

**Office of Education  
National Center for Educational Research and Development**

## TABLE OF CONTENTS

1. Introduction
2. Summary
3. Student Population and Limitations to Data
4. Student Performance
  - 4.1 Number of objectives learned
  - 4.2 Test results
  - 4.3 Gain in learning
  - 4.4 Learning time required
  - 4.5 Studies of subgroups
    - 4.5.1 Five high-scoring and five low-scoring students
    - 4.5.2 Five students using the greatest total learning time and five who used the least total learning time
    - 4.5.3 Students who finished the course early
    - 4.5.4 Summary
5. Media Usage
  - 5.1 Audio tape -- workbook
  - 5.2 Films
  - 5.3 Computer simulations
6. Student and Instructor Acceptance
  - 6.1 Reaction to the course as a whole
  - 6.2 Reaction to films
  - 6.3 Reaction to audio tape - workbook segments

Appendices

- A. Excerpts from TR-5.37
- B. Excerpts from TR-5.39
- C. Number of Core Segments and Core Objectives,  
Fall 1969
- D. Summaries of Responses on Student Critique Sheets

## 1. INTRODUCTION

The fact that the Multi-Media Economic Analysis Course, which represents a radical departure from the conventional way economics is taught, continues to be offered at the Naval Academy several semesters after its introduction attests to its acceptability, practicality, and success. The purpose of this report is to present the findings obtained in evaluating several important aspects of the Multi-Media Economic Analysis Course as it was presented at the United States Naval Academy during the evaluation semester (Fall 1969-70).

The following aspects of the course were evaluated:

1. Student performance
2. Student and instructor acceptance
3. Course management
4. General operational environment.

The questions related to these topics and the findings are summarized below and are discussed fully later on in the report. It is assumed that the reader is familiar with the contents of TR-5.37 (Economics Course Evaluation) and TR-5.39 (Final Validation Report); however, for convenience of the reader certain parts of these reports are included in Appendix A and Appendix B, respectively.

## 2. SUMMARY

The Multi-Media Economic Analysis Course in its fully operational mode was presented at the United States Naval Academy during the Fall Semester, 1969-70, to 39 randomly selected third class (sophomore) and second class (junior) Midshipmen who had not previously had any economics courses. In the course, the students proceeded at their own pace and exercised options in the selection of media and enrichment, and thus maintained a significant degree of control over when and how they studied. Whenever students have such freedom of choice, many questions arise concerning how well they learn, whether they can complete the course in the required time, whether they like having the responsibility for their learning, etc. During the evaluation of the course these and similar questions were investigated. Both the questions investigated and the findings are presented below.

1. Did the Midshipmen achieve at the expected level of performance?

Ninety-seven percent of the students achieved 80 percent or more of the core objectives of the course. Furthermore, 100 percent of the Midshipmen, in order to meet their learning contracts, accomplished varying numbers of enrichment objectives in addition to those in core. The Academy awarded a grade of "C" to students who achieved the core objectives.

Ninety percent of the students earned sufficient option points from their enrichment activities to obtain a final grade of "A" or "B".

2. What was the relationship between a student's rank in test performance and his rank in QPR, SATV and SATQ?

The correlations between rank in test performance and rank in QPR, SATV and SATQ were low and positive; however, for five tests the correlation between rank in QPR and rank in test performance was statistically significant. In the case of four tests the correlation between rank in SATQ and rank in test performance was also statistically significant. Consequently, it may be assumed that Midshipmen who rank high in SATQ and in QPR also tend to rank high in tests.



3. Did the students show a gain in learning?

From both the practical and statistical points of view all students showed a significant gain in learning. The amount of new information acquired and the increase in their ability to work with economic principles and concepts, as reflected in the difference between the scores on pretests and post tests, indicated a great increase in learning. In response to questionnaires, the Midshipmen reported that as a result of taking the course, they could perform better in activities such as discussing economic problems with parents, read with greater understanding newspaper stories related to economics, and criticize economic policy with a reasoned, stronger basis for their arguments.

4. Were the Midshipmen able to complete the course in one semester?

Although it is generally recognized that the Multi-Media Economic Analysis Course is the equivalent of a two-semester course, thirty-two percent of the students completed the course six weeks before the end of the semester. All of these students earned a final grade of A or B, which required that they also achieve enrichment objectives. One objective in designing the course was to produce course segments that the median student in the conventional course could complete in about 50 minutes' learning time. The median learning time

per segment for the Midshipmen in all concept areas was less than 50 minutes, as were the mean and modal learning times. The mean total learning time used by the Midshipmen for all the core materials in the Multi-Media Economics Course was 51 hours and 29 minutes, only 10 to 15 hours more than the time required for class attendance in the conventional course. The Naval Academy student with the greatest total learning time used 97 hours and 39 minutes for core materials, while the one with the least used 30 hours and 33 minutes.

Of considerable interest is the fact that both were among the group who completed the course in only nine calendar weeks. All others completed the economics course in one semester.

All correlations between a Midshipman's total learning time per test and his score on the corresponding test, as well as between his rank in total learning time per post test and his rank in SATV, SATQ and QPR, were low. Therefore, it may be concluded that little or no relationship existed between total learning time per test and any of these variables.

5. Did the five Midshipmen who made the highest scores on each control test differ significantly from those five who made the lowest scores in respect to mean total learning time? What was the correlation between rank in test scores and rank in learning time for each group? Was there any significant difference between the groups in respect to mean QPR and mean scores on SATV and SATQ?

The individuals included in the group making the five highest scores or in the group making the five lowest scores varied for every test. The mean total learning time of the five Midshipmen making the lowest scores was greater than that of the five making the highest scores in six of the nine tests; in the other three, the students with the highest scores had the greatest mean total learning time. Although the mean differences between the groups were statistically significant in only two tests, almost all were significant from a practical point of view because they usually amounted to an hour or more. A student and instructor, knowing of this difference, might be able to plan more efficient learning contracts.

The correlations between rank in test scores and rank in total learning time for the five Midshipmen with the highest test scores were either zero or less than .30 in all but two tests. On those two, the correlations, though high and negative (indicating a high, inverse relationship between learning time and test score) were not statistically significant. Correlations between the same variables for the groups making the lowest scores tended to be low and in three cases, the correlations were negative. These findings indicated little relationship between rank in test scores and rank in learning time among the low-scoring groups.

In general, the Midshipmen who were among the five making the highest scores on each test also scored higher on SATV and SATQ and had higher QPR's than the five making the

lowest scores. The difference in the mean QPR's of the groups was in all but one case statistically significant in favor of those with the high scores. However, in only three or four tests were the mean differences in SATV and SATQ scores statistically significant in favor of the groups of high scorers. Since the differences amounted to approximately 50 points, they had practical significance also.

6. Did the five Midshipmen who used the greatest total learning time differ significantly from the five who used the least total learning time in respect to test scores? What was the correlation between rank in learning time and rank in test scores for each group? Was there any significant difference between the groups in respect to mean QPR and mean SATV and SATQ scores?

The five Midshipmen using the least total learning time usually had a mean test score slightly higher (always less than 2 points) than those using the greatest total learning time. In no test was this difference either statistically or practically significant. These findings are typical of courses requiring the mastery of a high percentage of core material.

Correlations between rank in total learning time per test and rank in test scores for the group using the least total learning time were, with one exception, low and were inclined to be negative. The correlation between these variables on test 16 was  $-.84$ , indicating a high degree of inverse relationship. Students who took the least total learning time for this test

tended to have the lowest scores. Correlations between rank in total learning time per test and rank in test scores for the group using the greatest total learning time also were generally negative and low. However, on three tests the correlations were  $+0.89$ ,  $+0.87$ , and  $+0.84$ , showing a high, direct relationship between the two rankings. Among all these correlations only  $.89$  and  $.87$  were statistically significant. In the case of test 11 the correlation of  $-0.80$  indicates that students who required the greatest total learning time for this test tended to make the highest scores on it.

The personnel of the group of five Midshipmen using the least learning time and of the group using the greatest learning time varied from test to test. Although the mean QPR and the mean SATV and SATQ scores of the groups with the least learning time were higher than those of the other groups, the difference in the means for all three variables were generally neither statistically nor practically significant. However, the mean differences in SATQ of about 50 points favoring the group requiring the least total learning time for tests 72, 80 and 95 had both practical and statistical significance.

7. Did the group of Midshipmen who completed the course six weeks before the end of the semester differ significantly from the class as a whole in total learning time, test scores, QPR, SATV or SATQ scores?

The group of Midshipmen who completed the Multi-Media Economics Course in nine weeks were not different from the

class as a whole in total learning time, test scores, QPR, SATV or SATQ scores. They probably were different in motivation. Both the Midshipman who used the greatest total learning time for core content and the one who used the least were in the group. Moreover, three others who were in the groups taking the least total learning time per test and four who had been in the groups taking the greatest total learning time completed the course six weeks early. Eight of this group had been among the five with the highest test scores; four had been among the five with the lowest test scores. All statistical evidence pointed to the fact that these students were like the rest of the class in respect to total learning time, test scores, QPR, SATV scores and SATQ scores.

8. What conclusions can be drawn from these findings concerning the performance of the Midshipmen in the Multi-Media Economic Analysis Course?

The findings of these studies present conclusive evidence that the core materials in this economics course can be achieved in one semester or less by Naval Academy students similar to those in the experimental program at a 90/80 level of performance and that many can complete additional enrichment material at an equally high performance level within this same time period. The self-pacing feature of the course permits students who require a greater total learning time than their classmates to complete the course in one semester or less, also. These results imply that the design of the instructional

materials, which incorporated the sequencing of objectives, the conditions suitable for the type of learning inherent in each objective, and the reinforcement of correct responses, is sound. Eliminating any part of the design in revising this course could result in less spectacular student performance. On the basis of the findings concerning the performance of the Midshipmen, the Multi-Media Economics Course must be evaluated as highly successful in promoting efficient learning of economics by students at the Naval Academy.

9. Did Midshipmen who used audio packages learn the objectives for these segments as well as they learned those presented in the printed texts? How did the performance of these Midshipmen compare with that of the rest of the class in respect to test scores and total learning time?

The Midshipmen who elected to use the audio tape-workbook packages in general did not show great variation in their performance on test items referenced to the segments in the audio packages and on test items referenced to segments immediately preceding and immediately following the audio, which were presented in another medium printed text.

Comparisons of the percentage of correct items related to those segments prepared in alternate media for the group who used the audio and for the rest of the class were not significantly different, statistically or practically. On the whole, the mean total learning time of the audio group was somewhat less (5 - 10 minutes) than that of the rest of the class. For

one audio package the mean total learning time of the audio group was 17 minutes less; for a different package it was 20 minutes greater. These differences would be important to a busy Midshipman in deciding whether or not to try an audio package.

10. Did the Midshipmen who viewed the films have significantly better scores on test items related to the films?

Midshipmen who saw the films had a mean score on items referenced to them in test 27 which was one point higher than that of those not viewing the films. This difference was both practically and statistically significant. The difference in mean scores of viewers and non-viewers on items referenced to films in tests 48 and 72 was statistically but not practically significant.

11. How effective were the computer simulations?

The course included eleven computer simulations of economic systems. Some of these simulations are meant to challenge the most advanced student. No conclusions can be drawn concerning the effectiveness of the simulations, since the computer was usually down when a student needed it. With down time rates reportedly running as high as 80 percent for some students, students typically had to replan their schedules several times in order to run one simulation.



12. What was the student reaction to the course as a whole? What was the instructor's reaction?

Student reaction to the course was overwhelmingly favorable. They found it neither too easy, nor too hard and preferred the self-instructional approach to the traditional lecture approach. When asked to tell what they liked best about the course, they responded most frequently that they liked to be able to determine when, where, and how to study and to decide what final grade to work for. In response to a request for suggestions for improvement, they asked that more non-mandatory seminars relating economic principles to current policies and problems be held.

The instructor, too, was highly complimentary of the course because it promoted the learning of economics easily and well. Although he likes the lecture method, he appreciated the opportunity to work on a more individual basis with students which the self-instructional course afforded him. He, too, suggested there should be seminars concerning current problems and policies. (As the course is designed, the instructor determines when seminars are to be held and their topics. This may suggest that "required" seminars should be built into the course.)

13. What was student reaction to the films?

Reaction to the films was mixed. On the one hand, a majority of the students said that the films were an effective supplement to the course, and that they were relevant and

interesting; yet, a majority also reported under the category of what was least liked about the films that they were boring and a waste of time. There were other opinions expressed which were just as contradictory. In view of this reaction, the whole question of films should be reviewed.

14. What was student reaction to the audio tape-workbook packages?

Forty percent of the Midshipmen elected to use any audio-package series. Two of them used all three of the series; the others used one or two. About eighty percent of all the students utilizing this medium were favorably impressed because the tapes made learning easier for them and provided a change in pace. Those who disliked the tapes said they could not concentrate on economics while listening and found it difficult to go back over material they did not understand. A majority of those who used this medium suggested that more audio packages should be included in the course.

15. What problems, if any, existed in the general operational environment of the course?

A self-paced, self-instructional course requires that all materials and media be available to any student when he is ready for them. Operating such a course in the normal environment of the traditional school posed a number of problems in logistics. The Naval Academy solved many of these; however, a few such as coping with computer down-time apparently remain unsolved. Since the films were rented, they could be

shown only on a group, not individual, basis at a specified time. Consequently, the content of the films was not always congruent with that which the Midshipmen were learning. The facility in which the films were viewed and the hours when they could be seen were not completely satisfactory. The security of the space in which all materials, including control test and student records, were stored could not be ensured. Some breakdown in communication between instructor and students in respect to the scheduling of seminars and appointments was experienced. All these were problems typically connected with inaugurating a different type of course in any school.

### 3. STUDENT POPULATION AND LIMITATIONS TO DATA

In any detailed discussion of the Multi-Media Economic Analysis Course, the characteristics of the sample population who took the course should be considered at the outset. Thirty-nine Midshipmen at the United States Naval Academy, 13 second classmen (juniors) and 26 third classmen (sophomores), were randomly selected by the Academy to take the course during the Fall semester 1969-70. None of the students reported having previously had a course in economics. Table 1 presents the scores of the whole group on the SAT Verbal and the SAT Quantitative, as well as their Cumulative Quality Point Rank (QPR) as of 9/1/69. These data reveal a fairly wide range in all three measures as would be found in a random sample. The difference of 82 points between the mean score on the SATV and

the mean score on the SATQ is statistically significant at  $P < .01$  in favor of the SATQ and is probably characteristic of students in an institution oriented to Naval science and engineering such as the Naval Academy.

TABLE 1

The Mean, SD, Median, and Range of the QPR and of the Scores of 39 Midshipmen on the SATV and SATQ, 9/1/69

<u>Index</u>	<u>Mean</u>	<u>SD</u>	<u>Median</u>	<u>Range</u>
QPR	2.5	.5	2.315	1.66 - 3.83
SATV	587.4	59.3	580.00	486.00 - 719.00
SATQ	669.5	54.2	670.00	550.00 - 771.00

Figures 1, 2, 3 and 4 represent frequency distributions of the scores on the SATV and SATQ and the QPR for the Midshipmen. Although the mean QPR for the group is 2.5 (C+), 51 percent of the students have QPR's between 2.0 and 2.49, which is average or C level performance (see Figure 3 ).

The finding noted above, that there is a significant statistical difference between the mean SATV and the mean SATQ scores, is corroborated by the fact that, when frequency polygons are drawn and the means indicated on them as in Figure 4, the mean scores for the two tests do not fall in the same plane, giving rise to the assumption that the verbal and quantitative abilities of these students are different.

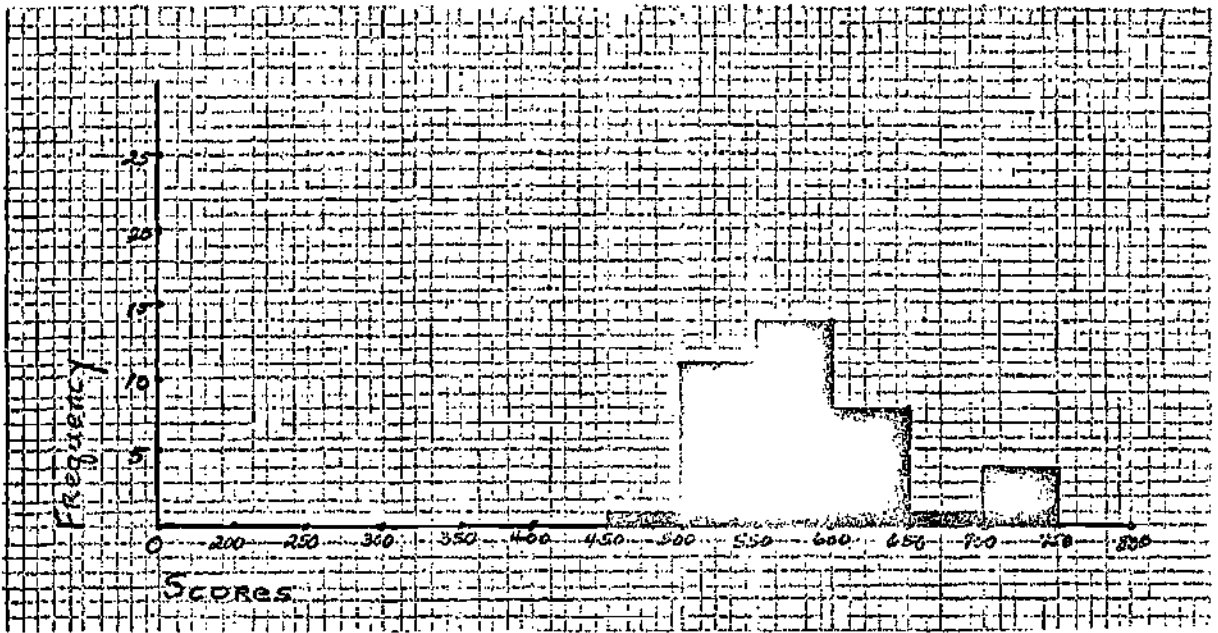

Fig. 1--Distribution of Score SATV

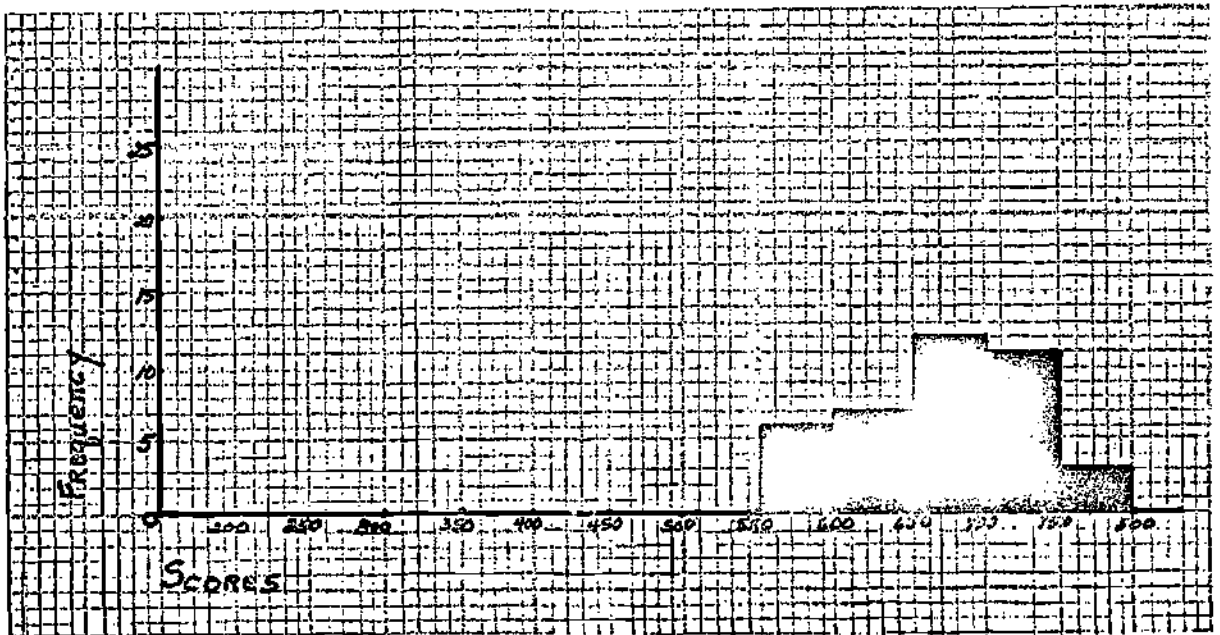

Fig. 2--Distribution of Scores SATQ

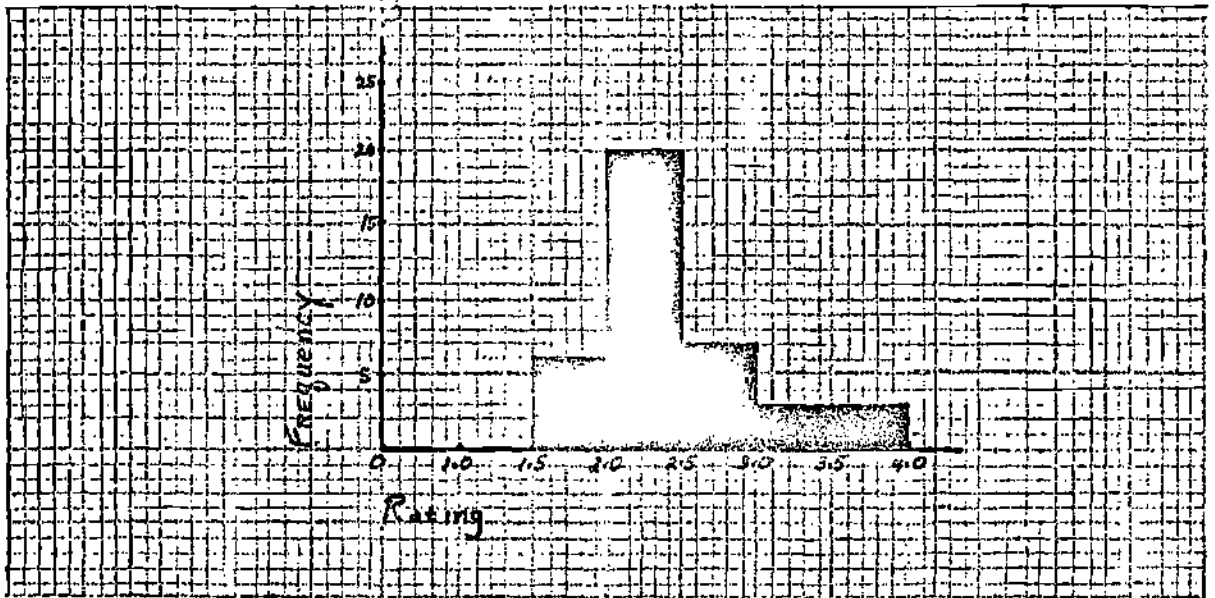

Fig. 3--Distribution of QPR

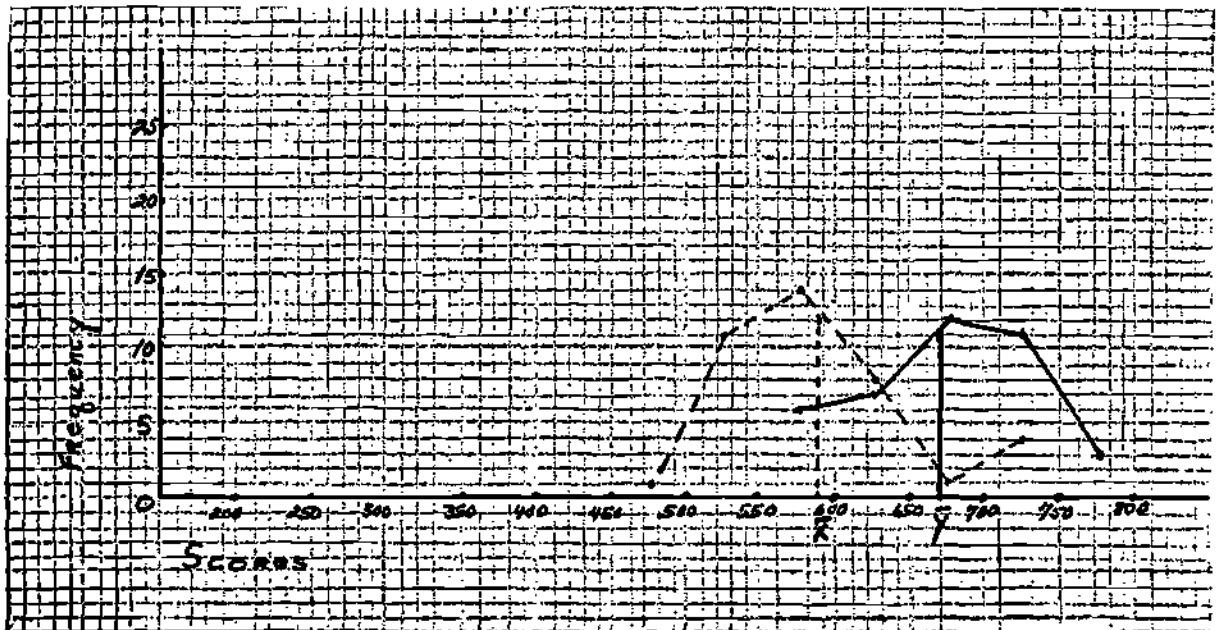

Fig. 4--Distributions and Means of  
 SATV and SATQ  
 SATV (X) -----  
 SATQ (Y) \_\_\_\_\_

Questions concerning the relationship of a student's rank in one variable with his rank in each of the other variables were also investigated. A test of the significance of the correlations reveals that the relationship between rank<sup>S</sup> in SATV and rank in QPR and between rank in SATQ and QPR are both significant (Table 2), indicating that students who rank high in SATV and SATQ also tend to rank high in QPR.

TABLE 2

Correlations of Ranks of 39 Midshipmen on SATV, SATQ and in QPR, 9/1/69

	<u>SATV</u>	<u>SATQ</u>	<u>QPR</u>
SATV	---	.28	.38*
SATQ	.28	---	.54**
QPR	.38*	.54**	---

\*P < .05  
\*\*P < .01

Although the key information in this report concerns the performance of Midshipmen who took the course during the Fall Semester, 1969-70, it is worthwhile, in the interest of determining how representative of the Naval Academy population these students are, to compare their mean scores on the SATV, SATQ and rank in QPR at the beginning of the course with the mean scores and rank on the same variables of the Midshipmen who took the course during the validation semester, Spring

<sup>S</sup> The rank order used was from high to low, the highest score receiving a rank of one.

1968-69.<sup>1</sup> That the two samples are from the same population is evidenced both from inspection of the mean scores and mean QPR of the two which are almost identical, as well as from a t-test of the significance of the difference between the means of the two groups in all three variables (Table 3).

TABLE 3

Comparison of the Mean Scores on SATV and SATQ and of the Mean QPR of Two Groups of Midshipmen Who Took the Multi-Media Economics Course

<u>Index</u>	<u>Mean-Group I</u> <u>Spring, 1968-9</u>	<u>Mean-Group II</u> <u>Fall, 1969-70</u>	<u>d<sub>f</sub></u>	<u>t-test</u>
SATV	589	587	68	.1413
SATQ	674	670	68	.3145
QPR	2.7	2.5	68	1.4717

The Midshipmen who took the course during the Fall semester, 1969-70 received a completely revised version of the one used during the validation phase, 1968-69. All changes were based on empirical evidence obtained during the validation trials. Although the course content remained essentially unchanged, some segments were rewritten; objectives were rearranged in segments; objectives were combined or omitted because they had already been presented in an earlier segment, and all tests

---

<sup>1</sup>It would have been interesting to compare the performance of the samples in these variables with the performance of the total population at the Naval Academy; however, the latter information was not available to us.



were revised.<sup>2</sup> Therefore, any comparisons of performance of the two groups on tests which might carry the same identification number would be spurious because, since the revision, the same objectives are not necessarily included in the two tests. Consequently, this study is generally limited to a report of what the Midshipmen who took the Fall, 1969 revision of the Multi-Media Economics Course did.

The collection of data was greatly facilitated during the evaluation semester by the course manager, who gathered the hundreds of Dymedia cards and saw that the needed information was recorded on them. As a result, there were only very minor data gaps, the most important of which concerns the amount of time used for review. The students recorded the total time spent in reviewing a group of segments, rather than the amount of time spent in reviewing each segment in the group. Since the review time was added to the segment just preceding the test, the total learning time for that segment was increased disproportionately; however, all other data concerning learning time was not affected. It has been noted also that one or two students may have recorded as their self-test time the total amount of time required for both the learning of the segment and the taking of the self-test, rather than only the latter. This tended to increase the total learning time.

---

<sup>2</sup>The number of core segments and core objectives in the Fall, 1969 Multi-Media Economics Course is given in Appendix C.

Not every student handed in a questionnaire after each test, and the instructor's critiques were obtained mainly from informal conversations rather than from the instructor's critique forms. Therefore, data concerning student acceptance is based on about 85 percent return of questionnaires.

Although there are the few flaws mentioned above, we found the data available quite complete and useful in obtaining meaningful analyses of the Multi-Media Economics Course, Fall semester 1969-70.

#### 4. STUDENT PERFORMANCE

##### 4.1 Number of Core Objectives Learned

A 90/80 (90 percent of the students learn 80 percent of the core objectives) goal was established for the evaluation semester of the course. However, not only 90 percent but 97 percent of the Midshipmen learned 80 percent of the core objectives of the course. It should be noted that along with the 595 explicit core objectives, of necessity, there are many implicit core objectives to be learned in the course. The latter are not represented in tests but should be recognized as additional learning which took place. Moreover, 100 percent of the Midshipmen elected as part of their learning contracts to take some enrichment which also entailed learning more objectives. How many enrichment objectives each student learned depended upon how much he contracted to learn. A student could earn option points to increase his grade by learning enrichment, and 90 percent of the Midshipmen earned sufficient option points

from their enrichment experiences to be awarded a final grade in the course of A or B.<sup>3</sup> In the light of the fact that 51 percent of the Midshipmen had, prior to taking this course, a QPR of C (2.0 through 2.49), having 90% of the students earn an A or B would seem to imply that this type of course motivated these students to learn.

How many objectives a student learned was indicated by his score on a post test given when the student had completed the work of each of the four concept areas. The post test consists of criterion referenced questions for each terminal objective in the concept area. Since the course is hierarchical in nature, it has been assumed that correctly answering the criterion referenced question for one terminal objective represents the learning not only of the terminal objective itself but also of all the enabling objectives supporting it. Thus, if the Midshipmen answered correctly 95 percent of the items on a post test, it was assumed that he had learned at least 95 percent of the terminal objectives and all the objectives subsumed under them. Tables 4, 5, 6 summarize the percentages of students in the validation semester and in the evaluation semester who learned 90 percent or more, 85 percent or more, and 80 percent or more of the core objectives.

---

<sup>3</sup>A grade of "C" was awarded by the Academy for successful completion of the core objectives of the course. A student could elect to earn a C, B, or A, depending on the number of objectives he achieved.

TABLE 4

The Percentage of Midshipmen Who Learned 90% or More of the Core Objectives Spring Semester 1968-69 and Fall Semester 1969-70, by Concept Area

<u>Concept Area</u>	<u>Spring Semester 1968-1969</u>	<u>Fall Semester 1969-1970</u>
I	13	95
II	58	64
III	17	33
IV	10	59

For both groups of students Concept Area III seems the most difficult since in both the percentage of students able to pass 90 percent or more of the terminal objectives is small. This may be accounted for in part by the fact that this concept area has more objectives to be learned than any other concept area and that the suggested number of weeks for learning the objectives is comparatively shorter than that for any other concept area. The increase in the percentage passing Concept Area I during 1969-70 probably reflects everyone's familiarity with the self-instructional course and improvements resulting from revisions.

TABLE 5

The Percentage of Midshipmen Who Learned 85% or More of the Core Objectives Spring Semester 1968-1969 and Fall Semester 1969-1970, by Concept Area

<u>Concept Area</u>	<u>Spring Semester 1968-1969</u>	<u>Fall Semester 1969-1970</u>
I	39	98
II	90	95
III	57	82
IV	23	84

The remarkable increase in the percentage of students who passed 85 percent or more of the objectives during the evaluation semester undoubtedly is due to the revisions made after the validation tryouts.

TABLE 6

The Percentage of Midshipmen Who Learned 80% or More of the Core Objectives Spring Semester 1968-1969 and Fall Semester, 1969-1970, by Concept Area

<u>Concept Area</u>	<u>Spring Semester 1968-1969</u>	<u>Fall Semester 1969-1970</u>
I	80	100
II	90	100
III	70	100
IV	50	97

Only one student did not learn 80 percent of the core objectives. He learned 76 percent and reported that he could have learned more had he not spent so much time working on

enrichment. Although his pattern of falling behind the proposed deadlines was apparent when he finished Concept Area II a month beyond the suggested deadline, he did not heed the warnings given to him at that time. The incident suggests that in the future those in charge of the course should be on the lookout for this type of student and that learning contracts for such students stipulate that core work must be satisfactorily completed before any enrichment may be attempted. The latter course of action was voluntarily chosen by several of the successful students during the evaluation semester.

#### 4.2 Test Results

Scores on all unit and post tests follow a pattern usually found in courses where students are required to master core learnings. The mean score on each test is very close to the highest possible score, and the measures of dispersion (range, standard deviation, standard error) are generally quite small (see Table 7).

TABLE 7

A Summary of Test Results for a Group of 39  
Midshipmen Who Took the Multi-Media Economics  
Course. Fall Semester 1969-70\*\*

<u>Test Number</u>	<u>Highest Possible Score</u>	<u>Mode</u>	<u>Median</u>	<u>Mean</u>	<u>Standard Devia- tion</u>	<u>Standard Error</u>	<u>Range</u>
2R*	30	14	13	12	5.1	.82	20 (00-20)
11T*	39	35	36	36	1.3	.21	5 (33-38)
16P*	30	28	28	28	1.8	.28	6 (24-30)
18R	51	0	10	11	8.4	1.34	35 (00-35)
27T	34	31,33	31	32	1.7	.28	5 (29-34)
39T	44	40,42	41	41	1.9	.30	7 (37-44)
48P	51	46	46	46	2.3	.37	9 (41-50)
50R	51	10	9	10	6.4	1.02	24 (00-24)
61T	32	31	31	30	1.3	.21	5 (27-32)
72T	38	34	34	34	1.3	.21	4 (32-36)
80P	51	44	44	45	2.5	.40	9 (41-50)
83R	37	0	3	5	5.7	.91	22 (00-22)
95P	37	32,35	33	33	2.1	.34	9 (27-36)

\*R indicates a pretest; T--a unit test; P--a post test.

\*\*All test results are reported in raw scores throughout the report.

Figures 5, 6, 10 and 11 are typical of the distributions of scores on mastery tests. Figures 7, 8, 12 and 13 illustrate the bi-modality of the test scores with one mode below and one mode above the mean in each test. The lone score of 27 shown

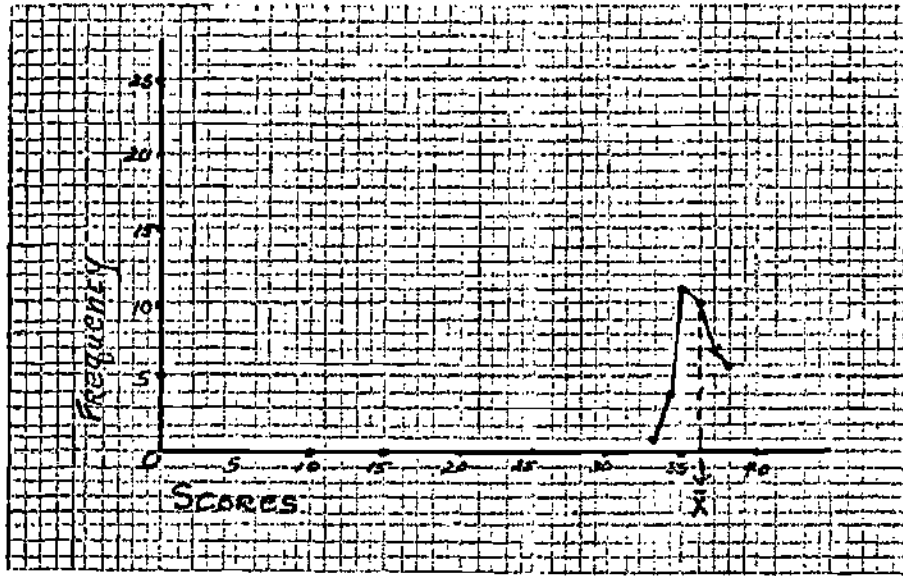

Fig. 5--Distribution of Scores Unit Test 11

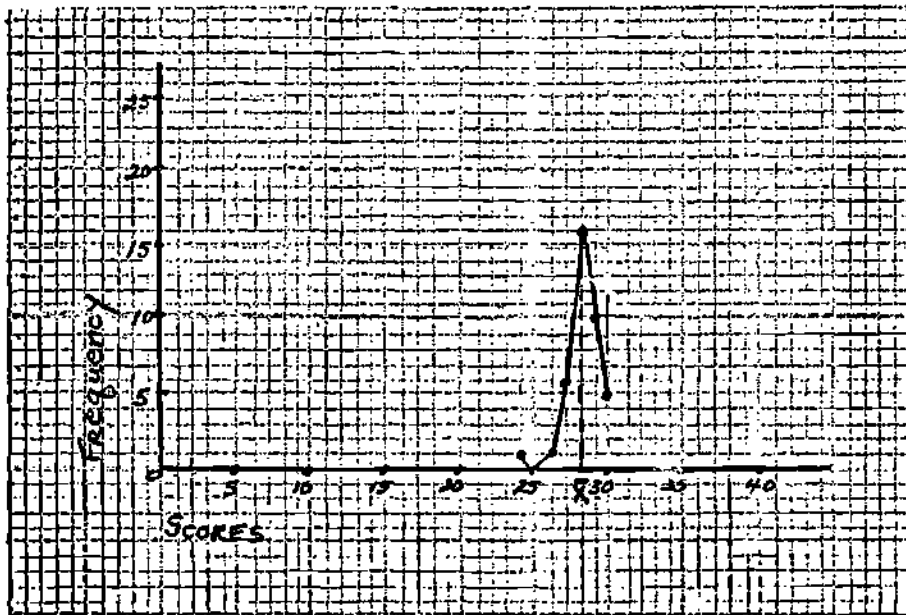

Fig. 6--Distribution of Scores Post Test 16



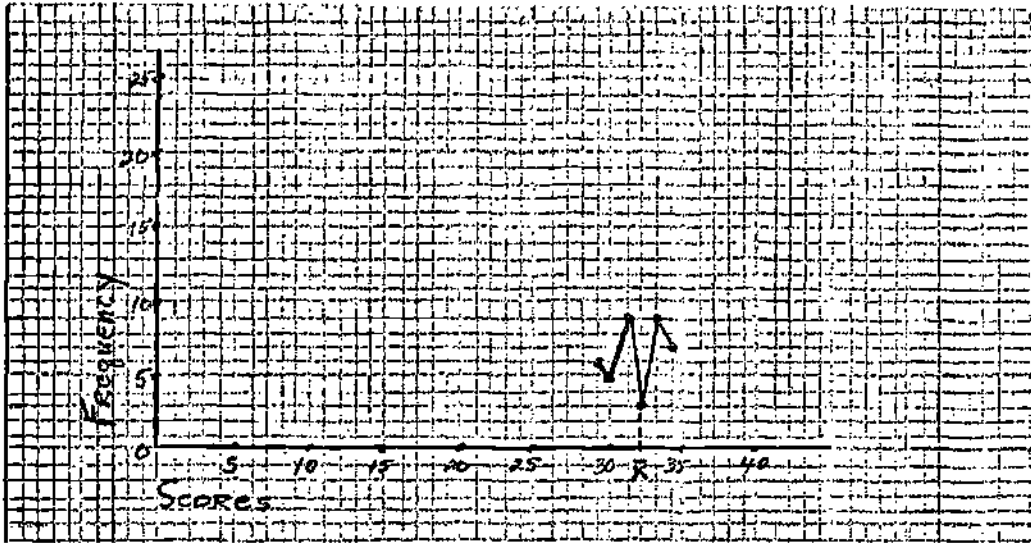

Fig. 7--Distribution of Scores Unit Test 27

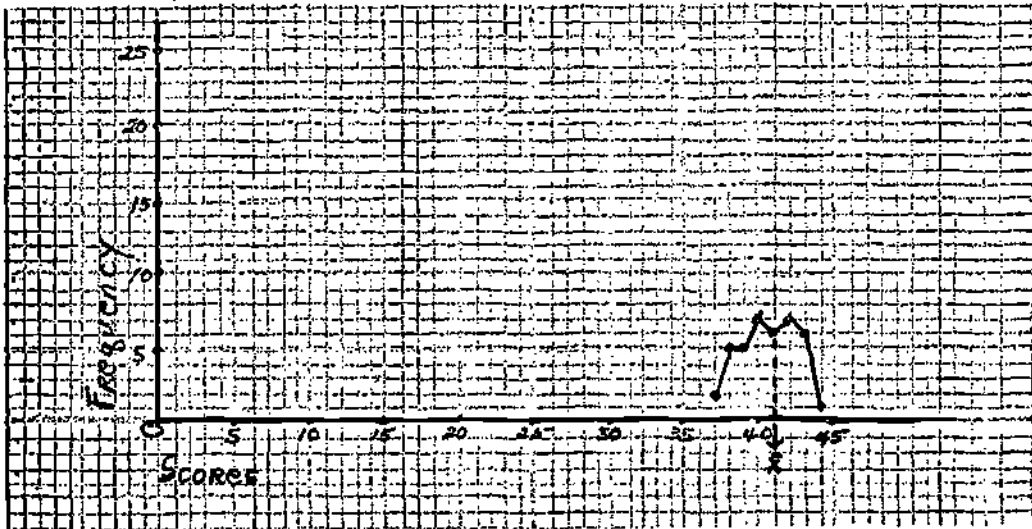

Fig. 8--Distribution of Scores Unit Test 39

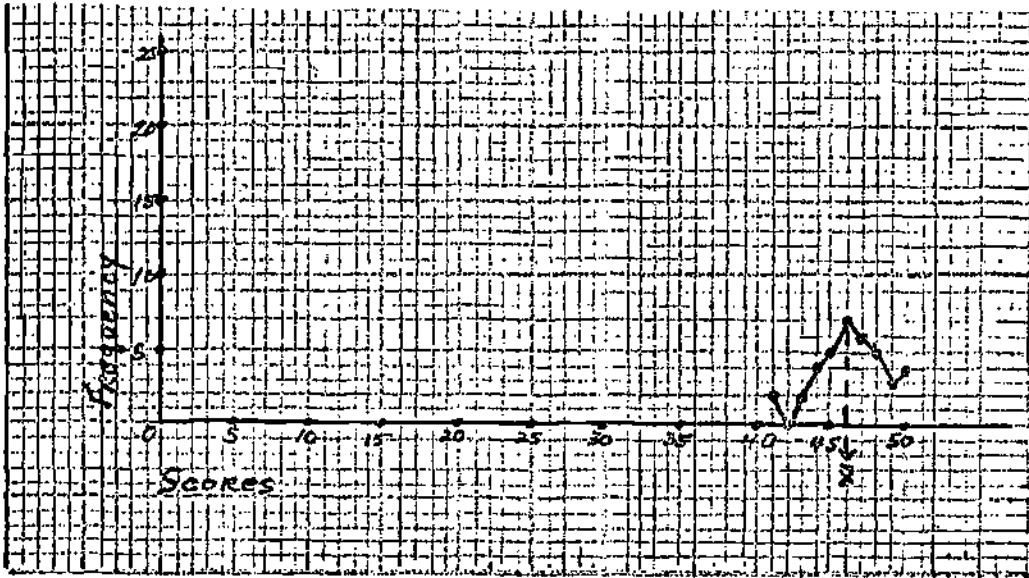

Fig. 9--Distribution of Scores Post Test 48

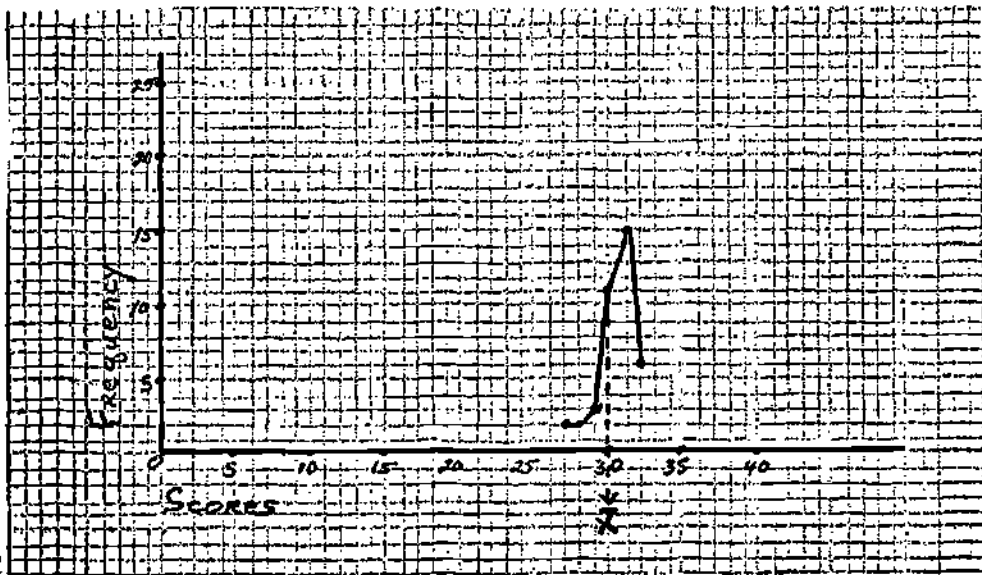

Fig. 10--Distribution of Scores Unit Test 61

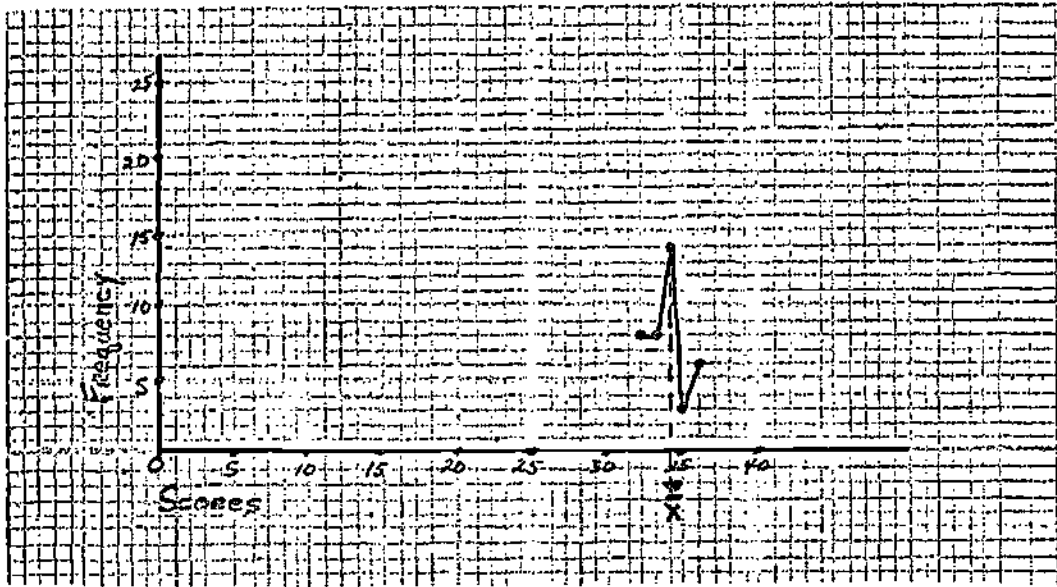

Fig. 11--Distribution of Scores Unit Test 72

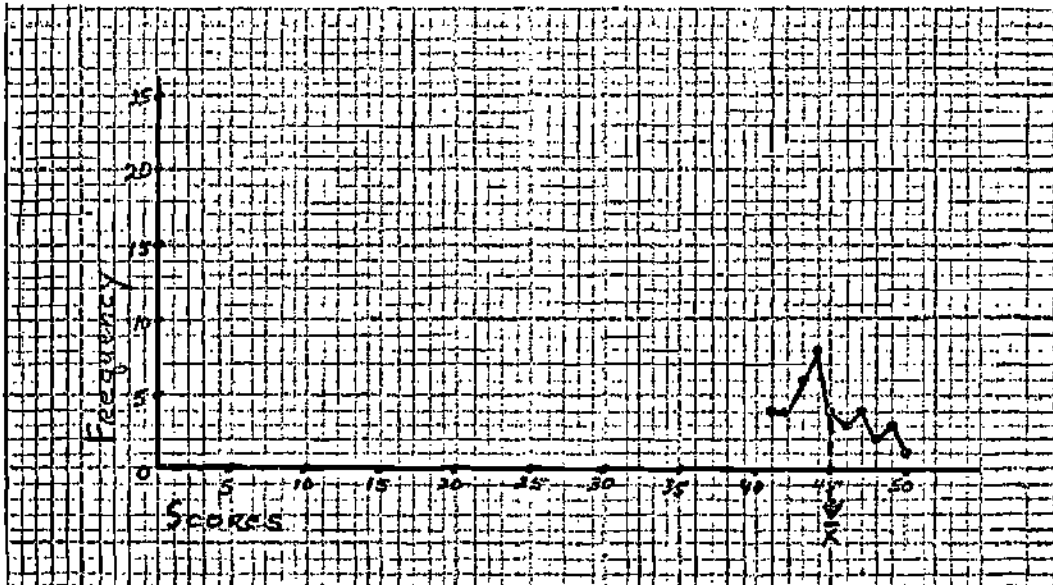

Fig. 12--Distribution of Scores Post Test 80

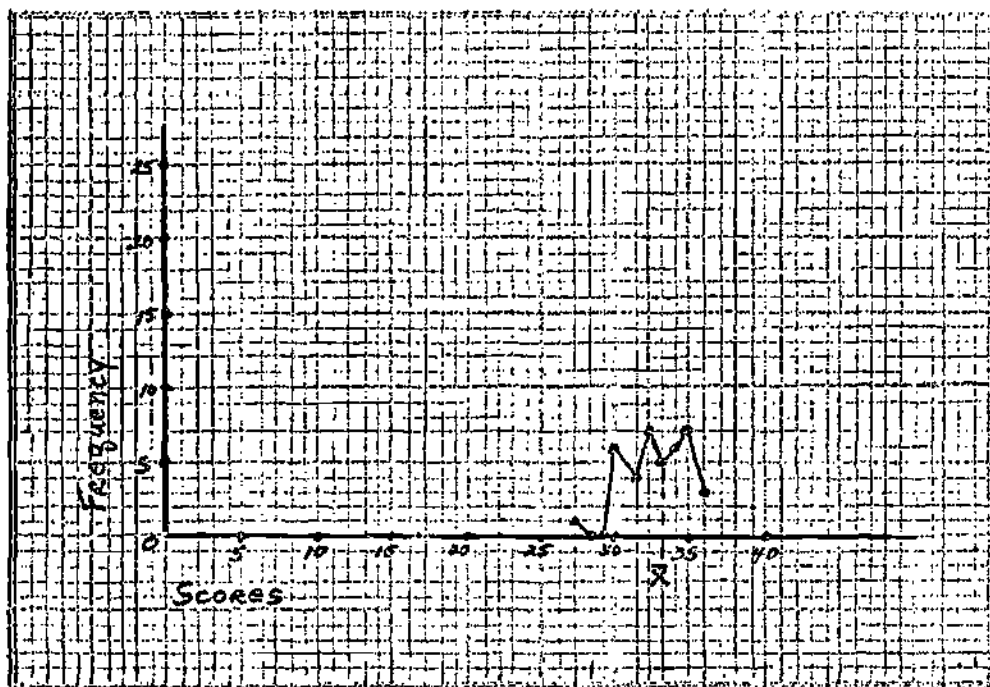

Fig. 13--Distribution of Scores Post Test 95

in Figure 13 belongs to the student who learned only 76 percent of the core objectives. All other low scores in any of Figures 5-13 represent learning a minimum of 80 or 85 percent of the core objectives.

Although there exists some correlation between rank in QPR and rank on SATV and SATQ, whether there exists a correlation between rank in these variables and rank in scores on tests was also investigated. Inasmuch as the self-instructional packages basically involve reading and comprehension skills, it might be assumed that students ranking high on the SAT Verbal would also rank high in their test scores. It might

also be expected that students ranking<sup>E</sup> high in QPR would also rank high in test performance. However, one of the main objectives of the project was to design an economics course such that any Midshipman, no matter what his previous ranks or classifications had been, could learn the core materials. In such a situation, there would be little relationship between the student's rank in SATV, SATQ, and QPR and his rank in test results.

The Multi-Media Economics Course meets the above objective to some extent. However, there exists as shown in the case of 5 tests, a significant correlation between rank in QPR and rank in test performance, and in the case of 4 tests a significant correlation between rank in SATQ and rank in test performance (see Table 8). Thus it would seem that students who ranked high in QPR and SATQ would tend also to rank high on tests.

---

<sup>E</sup>Rank order is from high to low with the highest score receiving a rank of one.

TABLE 8

Correlation of Rank in Test Performance with  
Rank in SATV, SATQ and QPR for  
39 USNA Midshipmen, Fall 1969-70

<u>Test</u>	<u>SATV</u>	<u>SATQ</u>	<u>QPR</u>
11T <sup>o</sup>	.13	.11	.23
16P <sup>o</sup>	.26	.38 *	.31
27T	.03	.27	.40 *
39T	.20	.55 **	.34 *
48P	.11	.42 **	.54 **
61T	.29	.28	.44 **
72T	.08	.05	.09
80P	.31	.40 *	.36 *
95P	.48 **	.13	.22

<sup>o</sup>T = Unit test; P = Post test

\*P < .05

\*\*P < .01

The correlations in Table 8 are very similar to those obtained during the validation phase (see Appendix B, p. 15). Obtaining similar results in both the evaluation and validation semesters tends to corroborate the conclusion that Midshipmen who rank high in SATQ and QPR also tend to rank high in tests.

### 4.3 Gain in Learning

Although the findings thus far indicate that the students learned the core objectives of the economics course, does this learning represent a significant increase in knowledge of economic concepts over that which they already possessed prior to taking the Multi-Media Economics Course? At the beginning of a concept area each student took a pretest designed to measure what he knew about the topics included in that concept area. Midshipmen were cautioned on the pretest to respond only to those questions for which they knew the answer and to leave the others blank. A study of pretest data shows that there was not one instance where a student achieved criterion performance (80 per cent) on any pretest. On the most elementary material contained in the first concept area, which involved the enabling objectives for all subsequent advanced objectives, no student achieved criterion performance. Since in no case did a student demonstrate on a pretest that he had mastered the objectives of a concept area, it was considered valid for the students to study the objectives. Later when a Midshipman had completed learning all the segments in the concept area, he was given a post test on those topics, a scrambled form of the pretest. It has been assumed that the difference between the scores on the two tests represents gain in learning.

The post test scores of the Midshipmen, both as individuals and as a group, are remarkably higher than the corresponding pretest scores, and inspection of the mean difference (Table 9) shows a gain in learning substantial enough

to be practical. Moreover, in their responses to questionnaires some students wrote that they had learned enough economics to enable them now to read newspaper articles concerning economic policies with more understanding than prior to taking the course; some that now they could discuss various topics in economics with their fathers; and others that their attitudes toward economics had become more favorable. (The questionnaires are discussed in greater detail later in the section "Student Acceptance.") A t-test of the significance of the difference between the mean score of each pretest and the mean score of each post test is statistically significant at  $P < .01$  (Table 9).

Therefore, we may conclude from this and the findings given in the preceding paragraphs that the gain in the learning of economics exhibited by the Midshipmen is both practically and statistically significant. And we may further conclude from the t-test that this increase is due not to chance but to some other intervening variable, in this case, to the self-instructional course materials.

TABLE 9

Comparison of the Mean Scores for Midshipmen  
on the Pretest and Post Test for Each Concept  
Area, Fall Semester 1969-70

Concept Area	Pretest Mean	Post Test Mean	Mean Difference	$d_f$	t-test
I	11.9	27.9	16.0	76	15.0*
II	10.5	46.3	35.8	76	29.5*
III	9.9	44.6	34.7	76	29.1*
IV	5.1	32.7	27.6	76	25.5*

\* $P < .01$



#### 4.4 Learning Time Required

"Learning time," as used in this report, refers to the number of minutes a student used in learning a segment of the course. Because all of the following activities, according to the design of the Multi-Media Economics Course, are integral parts of the conditions of learning, the learning time for a segment includes the number of minutes spent in reading the material related to each objective and completing the practice exercises embedded in it plus the time spent in taking the self-test and restudying objectives which, as revealed by the results of that test, had not been learned. The amount of time required for such tasks is quite different from that which would be spent in merely reading, scanning or covering the materials written about an objective. A student's total learning time for a test is the sum of the learning times for all segments included in the particular test. For example, the total learning time for Unit Test 11 is the sum of the student's learning time for segments 4, 5, 6, 7, 8, 9, and 10, while the total learning time for Post Test 16 represents the sum of the student's learning time for segments 4, 5, 6, 7, 8, 9, 10, 12, 13, 14 and 15. The amount of time spent in taking a unit test, a pretest or a post test is never included in learning time.

In section 4.1 we reported on the attainment of one of the objectives of the project; namely, to design a course in which 80 percent of the core materials could be learned by 90 percent of the students. Another objective was to design a

course whose core materials could be learned in one semester at the above mentioned level of performance by any student, regardless of his learning habits and abilities. This goal has also been achieved.

Thirty-two percent of the Midshipmen had completed the Multi-Media Economics Course by December 9, 1969, approximately six weeks before the end of the semester. All of these students had fulfilled contracts for an A or B grade, which meant that, in addition to learning core material, they had successfully completed the learning of several enrichment segments. One student who earned an A had completed the course as of November 14, 1969. Since the Multi-Media Economics Course has been generally recognized as the equivalent of a two-semester course, the fact that a third of the students completed it six weeks before the end of the semester indicates that the design of this self-instructional course is highly motivating and promotes efficient learning; i.e., the learning of large amounts of materials in less than the usually required amount of time.

Each segment has been designed to require approximately 50 minutes of learning time for the "C" student in the conventional system; however, the Midshipmen as a group have found this a generous estimate. Not only is their mean learning time per segment less than 50 minutes but so too are the median and mode (number of minutes most frequently recorded by the Midshipmen), and this occurs even though the range in learning time per segment is wide. Table 10 presents these data.

TABLE 10

The Mean, Median, Mode and Range of the Learning Time (in Minutes) Used by a Group of 39 Midshipmen, per Segment in Each Concept Area

<u>Concept Area</u>	<u>Mean</u>	<u>Median</u>	<u>Mode</u>	<u>Range</u>
I	49	45	45	15-180
II	39	33	25	11-208
III	42	35	30	10-440
IV	42	38	40	8-150

The broad range in learning time per segment is due in part to the fact that in several instances the students added their review time to the segment immediately preceding the test and also in part to the fact that some students found certain concepts very difficult and needed additional review time.<sup>3</sup>

The correlation of learning time with other variables has been investigated. What is the degree of relationship between a student's rank in total learning time<sup>5</sup> for each post test and his rank in SATV, SATQ and QPR? It might be postulated that students having the highest SATV scores would require less learning time than other students, (thus ranking high in learning time), giving a high positive correlation or that students having

---

<sup>3</sup>The limitations to the data have been discussed in section 3 of this report.

<sup>5</sup>Rank order of total learning time was from least to greatest, with the student who used the least total learning time receiving a rank of one.

the highest QPR would take more learning time than other students, giving a high negative correlation between these variables. However, the correlations between rank in total learning time per post test and rank in SATV, SATQ and QPR are low and not significant except for test 48 (Table 11). It may be concluded, therefore, that in general little or no relationship exists between a Midshipman's rank in the total learning time for each post test and his rank in either SATV, SATQ or QPR. Hence, how much learning time a certain type of student will need is not predictable from these data.

TABLE 11

Correlation of Rank in SATV, SATQ and QPR with Rank in Learning Time Required for Post Tests for 39 Midshipmen, Fall 1969

<u>Post Test</u>	<u>SATV</u>	<u>SATQ</u>	<u>QPR</u>
16	.24	.13	.13
48	.16	.35*	.12
80	.20	.28	.04
95	-.08	.25	.04

\*  $p < .05$

Does this same degree of relationship hold true between test scores and total amount of learning time used per test? Can it be said with any degree of certainty that students who spend the greatest amount of time in learning the core objectives score high on tests? The correlations between a Midshipman's total learning time per test and his corresponding test score are also very low and tend to be negative (Table 12). Therefore,

it may be concluded that there is little or no relationship between these variables. Also, this slight relationship tends to be inverse, indicating that those Midshipmen who take the least amount of learning time tend to score high on tests and vice versa. However, the correlations are so low that the only conclusion which can be reached with any degree of certainty is that there is little or no relationship between these variables. Consequently, no predications concerning the relationship between learning time and test performance can be made from these data.

TABLE 12

Correlations of Test Scores with Total Learning Time for that Test

<u>Test</u>	<u>r</u>
11T*	-.16
16P*	-.13
27T	.02
39T	-.19
48P	-.01
61T	-.05
72T	-.27
80P	.01
95P	-.05

\*T = Unit test; P = Post test

Since students, instructors and others when planning their work are usually interested in approximately how much learning time will be needed to complete learning the segments for a test, the mean total learning time required by the group of Midshipmen per control test has been determined. Inasmuch as post tests include items from each segment in an entire concept area, the mean total learning time for these tests is considerably larger than that for unit tests.

Although there are more objectives in all of Concept Area III, tested by 80P, than in all of Concept Area II, tested by 48P, students took on the average about an hour less total learning time for Concept Area III than for Concept Area II. On the other hand, however, in Concept Area III there was a smaller percentage of students who learned 90 percent and 85 percent of the core objectives than in Concept Area II (see Tables 4 and 5). All students passed 48P on the first try, whereas three students did not pass 80P on the first try. It is pertinent to note that during a fall semester Concept Area III is usually studied in the period between Thanksgiving and Christmas, and in a spring semester in the weeks around Easter. Both are times when motivation to study economics may be difficult for students to maintain, and this may account in part for the above findings.

TABLE 13

The Mean, SD, Standard Error, and Range of Total Learning Time  
(in Minutes) Used by 39 Midshipmen, Fall 1969, per Control Test

<u>Test Number</u>	<u>No. of Segments Tested</u>	<u>No. of Objectives Tested</u>	<u>Mean Total Learning Time</u>	<u>SD</u>	<u>SE</u>	<u>Range</u>
11T*	7	81	374 (6'14")	87.9 (1'28")	14	400 (255-655) (6'40")
16P*	11	122	535 (8'55")	132.1 (2'12")	21.2	661 (349-1010) (11'1")
27T	9	60	298 (4'58")	94.0 (1'34")	15.1	370 (148-518) (6'10")
39T	11	85	456 (7'36")	150.9 (2'31")	24.2	579 (241-820) (9'39")
48P	27	192	1046 (17'26")	326.0 (5'26")	52.2	1251 (619-1870) (20'51")
61T	9	63	303 (5'3")	110.3 (1'50")	17.7	420 (165-585) (7')
72T	9	74	428 (7'8")	155.7 (2'36")	24.9	433 (230-663) (7'13")
80P	25	204	1003 (16'43")	354.7 (5'55")	56.8	1700 (545-2245) (28'20")
95P	12	77	508 (8'28")	194.3 (3'14")	31.1	921 (240-1161) (15'21")

\*T = Unit test; P = Post test

The final question to be answered concerning total learning time is: What is the mean total learning time used by Midshipmen to complete all core segments in the entire Multi-Media Economics Course? The mean total learning time for this group of Midshipmen is 51 hours and 29 minutes (Table 14). The student taking the least amount of total learning time spent 30 hours and 33 minutes, while the student taking the greatest amount used 97 hours and 39 minutes, a difference of 67 hours and 6 minutes. It should be noted again that each Midshipman upon completing a segment recorded the number of minutes he used in learning it, and the above results were obtained from the students' figures. The total learning time does not include time spent in taking pretests, post tests and unit tests, which would be an additional 7 hours and 45 minutes.

TABLE 14

The Mean, SD, SE and Range of the Total Learning Time Used by a Group of 39 Midshipmen in Learning Core Objectives of the Multi-Media Economics Course, Fall 1969

<u>Mean</u>	<u>SD</u>	<u>SE</u>	<u>Range</u>
51'39"	15'52"	2'32"	30'33" - 97'39" (67'06")

Usually the student in a conventional economics course spends 36 to 45 hours per semester just attending class, and he is expected to spend an additional 72 to 90 hours in outside reading and study, a total of 108 to 135 hours for a three-credit course. However, the majority of students do not use



that much time in learning the conventional economics course, and the question of how much real time is used by them was not investigated for this report. But whether Midshipmen taking the greatest total learning time can in one semester finish the Multi-Media Economics Course, including taking tests and completing enough enrichment activities for a final grade of A, has been investigated. The findings indicate that students can do this. In fact, the Midshipman who required the greatest total learning time and the one who required the least were among those who completed the economics course six weeks before the end of the semester, and both earned a final grade of A.

When we remember that the Multi-Media Economics Course has been recognized as the equivalent of a two semester course, the fact that the Midshipmen required a mean total learning time for core materials of 51½ hours (59½ hours including testing), only a few hours more than class time in a conventional lecture course, and that they exceeded a 90/80 performance level, is strong evidence of the success of this economics course in promoting effective and efficient learning. The self-instructional, self-paced aspects of this course permitted the Midshipmen to meet their individual requirements as to when and how they would study and for what final grade they would work, and obviously this resulted in learning a large amount of material, in a comparatively short time, at a high level of performance. It should not be assumed, however, that since the total learning time for the Naval Academy students for the

core materials, including taking the tests, is on the average the equivalent of approximately eight 8-hour days, that we recommend learning the core materials in eight days or less. We do not. The economics course abounds in fairly complex and abstract principles which need to be assimilated and seen in perspective, and participating over time in seminars or in enrichment activities permits assimilation and seeing relationships. Therefore, we recommend that students continue to set their own goals and their own paces, but that they be encouraged to consider recommended time frames when making their decisions in these matters.

#### 4.5 Studies of Subgroups

To examine in depth the relationships between total learning time and test performance, three subgroups of Midshipmen were studied. One subgroup comprises 10 Midshipmen, the five who scored lowest and the five who scored highest on each control test; a second, also 10 Midshipmen, the five who took the greatest amount and the five who took the least amount of total learning time; and a third, of 12 Midshipmen who completed the Multi-Media Economics Course six weeks before the end of the semester. The findings related to each subgroup are treated separately. Since small differences in the performance of these subgroups may be of practical significance to instructors, students and administrators, we have used a .2 probability level for the statistical test of the significance of the differences in means.

#### 4.5.1 Midshipmen with Highest Test Scores and with Lowest Test Scores

The relationship between learning time and either high or low test performance is of major importance in this project. Originally, the evaluation design proposed a study of the relationship between the scores and learning time of those students scoring in the top ten per cent and bottom ten per cent on each test. However, at that time estimates of the number of students who might be chosen to take the Multi-Media Economics Course varied from 15 to 44, a range of 1.5 to 4.4 students in the top or bottom ten per cent. In order to preclude the possibility of having only one or two students in a group and in order to keep within a small percentage range, it was decided to study the five Midshipmen who scored low on each test and the five who scored high and the five who took the greatest total learning time and the five who took the least. The first question studied was: Do the Midshipmen who score highest (Group H) differ significantly in mean total learning time per control test from the 5 who score lowest (Group L)? The findings are summarized in Table 15.

TABLE 15

Comparison of the Mean Total Learning Time (Minutes)  
Used by the 5 Midshipmen Who Scored Highest (Group H)  
and the 5 Who Scored Lowest (Group L) on Each Control  
Test, Fall 1969

Test Number	Total Learning Time Group H		Total Learning Time Group L		Mean Difference	t-test
	Mean	SD	Mean	SD		
11T <sup>o</sup>	338 (5'38")	66 (1'06")	393 (6'33")	42 (42")	-55 (55")	1.5544*
16P <sup>o</sup>	562 (9'22")	178 (2'58")	674 (11'14")	203 (3'23")	-112 (1'52")	.9306
27T	218 (3'38")	43 (43")	304 (5'04")	137 (2'17")	-86 (1'26")	1.3401
39T	422 (7'02")	63 (1'03")	517 (8'37")	164 (2'44")	-95 (1'35")	1.2159
48P	1161 (19'21")	417 (6'57")	998 (16'38")	286 (4'46")	+163 (2'43")	.7218
61T	312 (5'12")	157 (2'37")	289 (4'49")	105 (1'45")	+23 (23")	.2715
72T	456 (7'26")	114 (1'54")	668 (11'08")	265 (4'25")	-212 (3'32")	1.7254*
80P	988 (16'28")	414 (6'54")	906 (15'06")	282 (16'28")	+82 (1'22")	.3641
95P	445 (7'25")	99 (1'39")	439 (7'19")	102 (1'42")	-06 (06")	.0977

<sup>o</sup> T = Unit test; P = post test

\*  $P < .2$

In all but three tests the lowest scoring students have a greater mean total learning time than the highest scoring students. In the three others the reverse is true. For unit test 61 and post test 95, the mean difference between the two groups is so low as to have neither practical nor statistical significance. However, the additional time spent by low scoring students in learning materials for tests 11, 16, 27, 72 and 80 has practical significance for instructors or course managers who, armed with such information, may be able to assist Midshipmen planning contracts to more realistically determine how much they may be able to accomplish with suggested time limits. In the case of tests 11 and 72 the mean difference is also statistically significant.

The same students do not consistently appear in either group on every test. Only one Midshipman scored among the lowest in 7 out of 9 tests, one in 6 out of the nine, and only three or four in 2 or 3 of the nine. The remainder appear only once in this group. This is also true for those in the high-scoring groups, with the exception that only 1 Midshipman scored high in 6 out of 9, and none in 7 out of 9 tests. Whether the group with high scores differs significantly in QPR and scores on SATV and SATQ from the group with low scores is a question raised for this investigation. In general, the Midshipmen who were among those making the five highest scores have higher QPR's and score higher in SATV and SATQ (Table 16).

TABLE 16

Comparison of the Mean QPR of the 5 Midshipmen  
Who Scored Highest (Group H) and the 5 Who Scored  
Lowest (Group L) on Each Control Test, Fall 1969

Test Number	QPR-Group H		QPR - Group L		Mean Difference	t-test
	Mean	SD	Mean	SD		
11T <sup>o</sup>	2.47	.37	2.15	.23	.32	1.6370*
16P <sup>o</sup>	2.89	.50	2.22	.22	.67	2.7102*
27T	2.83	.67	2.01	.25	.82	2.6005*
39T	2.91	.54	2.38	.47	.53	1.6400*
48P	2.62	.65	1.94	.17	.68	2.2875*
61T	2.53	.32	2.14	.46	.39	1.5720*
72T	2.43	.34	2.22	.38	.21	0.9112
80P	3.18	.57	2.13	.10	1.05	4.0304**
95P	2.53	.41	2.02	.08	.51	2.7216*

<sup>o</sup>T = Unit test; P = Post test

\* P < .2

\*\*p < .2 and P < .01

The difference in the mean QPR of the two groups is generally about .50 (half a rank point), and the standard deviations are large enough so that there is overlapping between groups. However, the Midshipmen with high scores tend to have a mean QPR above 2.50 (C+ or better), whereas those with the low tend to have one nearer 2.00 (C). In all but one test the mean difference between groups is statistically significant in favor of Group H. These

findings concerning QPR are consistent with those for the class as a whole, reported on Table 1 of this report.

TABLE 17

Comparison of the Mean SATV Score of the 5 Midshipmen Who Scored Highest (Group H) and the 5 Who Scored Lowest (Group L) on Each Control Test, Fall 1969

Test Number	SATV-Group H		SATV-Group L		Mean Difference	t-test
	Mean	SD	Mean	SD		
11T <sup>O</sup>	549	34	571	32	-22	1.0735
16P <sup>O</sup>	576	37	541	62	35	1.0858
27T	583	47	581	42	02	0.0641
39T	624	83	578	81	46	0.8953
48P	597	80	574	53	23	0.5165
61T	629	24	572	52	57	2.2034*
72T	553	35	531	33	22	1.0027
80P	662	48	588	69	74	1.9705*
95P	604	63	543	42	61	1.7987*

<sup>O</sup>T = Unit test; P = Post test  
\*P < .2

TABLE 18

Comparison of the Mean SATQ Score of the 5 Midshipmen Who Scored Highest (Group H) and the 5 Who Scored Lowest (Group L) on Each Control Test, Fall 1969

Test Number	SATQ-Group H		SATQ-Group L		Mean Difference	t-test
	Mean	SD	Mean	SD		
11T <sup>o</sup>	646	84	647	39	-01	-0.0338
16P <sup>o</sup>	702	40	645	39	57	2.2544*
27T	711	32	648	42	63	2.6886*
39T	728	57	650	43	78	2.4481*
48P	686	75	634	37	52	1.4061
61T	674	67	647	49	27	0.7188
72T	670	53	643	42	27	0.8850
80P	727	20	634	60	93	3.2777*
95P	683	78	644	52	39	0.9253

<sup>o</sup>T = Unit test; P = Post test  
\*p < .2

In test 11 the low-scoring group has a higher mean score on both the SATV and the SATQ than the high scoring group; however, in neither case is the difference of practical or statistical significance. In those tests where the mean difference between the groups in either the SATV or the SATQ scores is 50 points or more, the difference is statistically significant. However, the mean SATV scores for both the high scorers and the low scorers are somewhat lower than would be expected when compared to the mean of the class as a whole (Table 1). On the



other hand, except in the case of test 11, the mean SATQ scores for the high and low scoring groups are consistent with those reported for the class as a whole in Table 1.

Having determined the significance of the mean difference for the groups in respect to total learning time, QPR, SATV and SATQ scores, there remains the question of how great is the correlation between their rank in test performance and their rank in learning time.<sup>S</sup> In both tests 39T and 80P the r's

TABLE 19

Correlation of Rank in Test Scores and Rank in Learning Time per Test for the 5 Midshipmen Who Scored Highest (Group H) and the 5 Who Scored Lowest (Group L), Fall 1969

<u>Test Number</u>	<u>Group H</u>	<u>Group L</u>
11T <sup>O</sup>	.00	.40
16P <sup>O</sup>	.00	.37
27T	.00	.00
39T	-.82	-.64
48P	.28	-.10
61T	.00	.65
72T	.00	.00
80P	-.71	-.43
95P	.07	.42

<sup>O</sup>T = Unit test; P = Post test

<sup>S</sup>The rank order for test performance was from high score to low score; for total learning time from least to greatest. The highest score was ranked 1 and the least total learning time also was ranked 1.

of  $-.82$  and  $-.71$  respectively indicate a high degree of inverse relationship between test score rank and rank in learning time for the Midshipmen with highest scores (Table 19), although for this small sample neither of these correlations is significant at  $P < .05$ . This means that the Naval Academy students who scored high on these tests generally took the greatest amount of learning time. The correlation of  $-.64$  in test 39 for the group with the lowest scores is also noteworthy. It indicates that those Midshipmen who made the lowest scores on test 39 tended to use the least amount of learning time; whereas, the correlation of  $+.65$  in test 61 shows a tendency for the same Midshipmen to use a great amount of learning time for that test. The very low or zero correlations obtained for these variables on all other tests and for both groups may be interpreted as indicating little or no relationship between test scores and learning time.

#### 4.5.2 Midshipmen Using the Least Learning Time and the Greatest Learning Time

The question, do the test scores of the 5 Midshipmen who used the least total learning time (Group LLT) per control test differ significantly from the scores of the 5 who took the greatest total learning time (Group GLT), was also studied. Table 20 summarizes the results of this investigation.

TABLE 20

Comparison of the Mean Test Scores of the 5 Midshipmen Who Used the Least Learning Time (Group LLT) and the 5 Who Used the Greatest Learning Time (Group GLT) per Control Test Fall, 1969

Test Number	Group LLT		Group GLT		Mean Difference	t-test
	Mean	SD	Mean	SD		
11T <sup>o</sup>	36.4	1.6	34.6	2.7	1.8	1.2990
16P <sup>o</sup>	28.2	1.1	27.4	2.2	0.8	0.7303
27T	31.6	1.9	32.0	1.9	-0.4	0.3310
39T	40.2	1.1	39.8	2.0	0.4	0.3849
48P	45.4	2.7	46.8	2.2	-1.4	0.9037
61T	30.6	1.1	30.6	1.3	0.0	0.0000
72T	34.0	0.7	33.2	1.8	0.8	0.9300
80P	44.2	2.9	44.8	3.1	-0.6	0.3128
95P	32.8	2.4	32.6	1.1	0.2	0.1690

<sup>o</sup>T = Unit test; P = Post test

In no case is the difference between the mean scores of the groups two points; in fact, it is generally merely a fraction of one point. Midshipmen using the least learning time have a mean score slightly higher than those with the greatest learning time, except on test 48 for which the reverse is true. From both a practical and a statistical point of view, there is no difference in the performance of the groups, a finding which is to be expected in a course requiring the mastery of a high percentage of core material.

One Midshipman consistently appeared in every group using the greatest total learning time; another appeared in the group for 8 out of 9 tests; and 2 students in 6 out of nine. Among those using the least total learning time, one Midshipman appeared in the group 7 out of 9 times, and 2 in 6 out of 9. On the whole, a very few students consistently were among those using the greatest or the least total learning time for a test. The personnel of the groups varied. In view of this fact, do the two groups differ significantly in respect to QPR and scores on SATV and SATQ?

TABLE 21

Comparison of the Mean QPR of the 5 Midshipmen Who Used the Least Total Learning Time (Group LLT) and the 5 Who Used the Greatest Total Learning Time (Group GLT) per Control Test, Fall 1969

<u>Test Number</u>	<u>Group LLT</u>		<u>Group GLT</u>		<u>Mean Difference</u>	<u>t-test</u>
	<u>Mean</u>	<u>SD</u>	<u>Mean</u>	<u>SD</u>		
11T <sup>o</sup>	2.35	.48	2.23	.40	.12	0.4141
16P <sup>o</sup>	2.35	.48	2.34	.37	.01	0.0220
27T	2.68	.83	2.60	.39	.08	0.1851
39T	2.53	.82	2.38	.33	.15	0.3947
48P	2.57	.81	2.38	.32	.19	0.4960
61T	2.40	.83	2.22	.21	.18	0.4902
72T	2.61	.69	2.20	.24	.41	1.2587
80P	2.61	.69	2.20	.23	.41	1.2742
95P	2.48	.33	2.20	.24	.28	1.5598*

<sup>o</sup>T = Unit test; P = Post test  
\* P < .2

The mean difference in QPR between the groups is less than .50 (one half a rank point) in all cases (Table 21), and except for tests 72 and 80 there is no practical difference in the mean QPR of the groups. The Naval Academy students requiring the least total learning time for tests 72 and 80 have a mean which is .41 points higher than that of the other group, indicating that these students may tend to have a C+ or better average while the others tend to have a somewhat lower one of C. This difference, however, is not statistically significant. A smaller mean difference for test 95 is statistically significant, although the latter, from a practical point of view is not as significant as the mean differences occurring in tests 72 and 80.

TABLE 22

Comparison of the Mean SATV Scores of the 5 Midshipmen Who Used the Least Total Learning Time (Group LLT) and the 5 Who Used the Greatest Total Learning Time (Group GLT) per Control Test, Fall 1969

Test Number	Group LLT		Group GLT		Mean Difference	t-test
	Mean	SD	Mean	SD		
11T <sup>o</sup>	594	55	586	47	08	0.2273
16P <sup>o</sup>	594	55	582	53	12	0.3486
27T	634	65	610	83	24	0.5189
39T	622	52	579	63	43	1.1640
48P	607	55	579	63	28	0.7469
61T	616	64	553	64	63	1.5765*
72T	590	56	554	60	36	0.9876
80P	590	56	566	57	24	0.6644
95P	578	58	566	57	12	0.3189

<sup>o</sup>T = Unit test; P = Post test

\*P < .2

Referring to Table 22, we see that for only one test is the difference in the mean SATV score for Group LLT significantly different, both practically and statistically, from that of Group GLT. In all other tests the mean scores are very similar to the mean SATV for the class as a whole (Table 1).

TABLE 23

Comparison of the Mean SATQ Scores of the 5 Midshipmen Who Used the Least Total Learning Time (Group LLT) and the 5 Who Used the Greatest Total Learning Time (Group GLT) per Control Test, Fall 1969

<u>Test Number</u>	<u>Group LLT</u>		<u>Group GLT</u>		<u>Mean Difference</u>	<u>t-test</u>
	<u>Mean</u>	<u>SD</u>	<u>Mean</u>	<u>SD</u>		
11T <sup>o</sup>	693	41	678	34	15	0.6613
16P <sup>o</sup>	693	41	671	33	22	0.9614
27T	679	86	652	64	27	0.5597
39T	664	71	651	63	13	0.3101
48P	661	70	651	63	10	0.2467
61T	662	70	638	56	24	0.6143
72T	696	24	649	42	47	2.1500*
80P	696	24	627	60	69	2.3626*
95P	701	22	627	60	74	2.5827*

<sup>o</sup>T = Unit test; P = Post test  
\*p < .2

As summarized in Table 23, the data concerning the mean difference in SATQ scores for the two groups show that on tests 72, 80 and 95 fairly large differences exist between the means

of the two groups favor of Group LLT. Since the standard deviation of the mean of the latter group is small, the mean difference for all three tests is statistically significant. It is also interesting to note that although the mean scores of the two groups on all tests are within one standard deviation (plus or minus) of the mean SATQ score for the class as a whole, a closer inspection of the mean and standard deviation of Group GLT for tests 61, 80 and 95 reveals the probability that half of these students are among those with the lowest SATQ scores for the class as a whole. These facts have some practical significance for the relationship between the content of the Multi-Media Economics Course and learning time. Midshipmen who use the least total learning time on tests 72, 80 and 95, as a group, have SATQ scores 50 or more points higher than those using the greatest total learning time. Inasmuch as the materials for the objectives tested in tests 72 and 80 contain many quantitative analyses, students with higher quantitative abilities probably find these concepts easier to learn and spend less time in the process. This information could be helpful to students and instructors when planning learning contracts for Concept Area III.

In addition to the studies of the test scores of Groups LLT and GLT, an investigation of the degree of relationship between rank in test performance and rank in total learning time of the students in these groups was also conducted. The results are summarized in Table 24 below.

TABLE 24

Correlation of Rank in Test Scores and Rank in Total Learning Time per Test for the 5 Midshipmen Who Used the Least Total Learning Time (Group LLT) and the 5 Who Used the Greatest Total Learning Time (Group GLT), Fall 1969

<u>Test Number</u>	<u>Group LLT</u>	<u>Group GLT</u>
11T <sup>o</sup>	.15	-.80
16P <sup>o</sup>	-.84	-.04
27T	.35	-.10
39T	.02	-.11
48P	.07	-.53
61T	-.48	-.41
72T	-.44	+ .89 *
80P	-.31	+ .87 *
95P	.01	+ .84

<sup>o</sup>T = Unit test; P = Post test

\*P < .05

The five correlations of .30 or above indicate a high degree of relationship between the variables in the case of those particular tests, but only two of these correlations are statistically significant. The fact that there is one more negative than positive correlation among all those reported shows a tendency for the variables to be inversely related. The r of  $-.84$  for Group LLT shows that the Midshipmen who took the least total learning time for test 16 frequently made the lowest scores on that test; however, in the case of such a small group this correlation is not statistically significant. Although there are other negative correlations reported for this group, they are so low as to



warrant the conclusion that there is little or no relationship between test performance and learning time for Midshipmen who take the least total learning time.

However, can the same conclusions be drawn regarding Group GLT? The correlation of  $-.80$  indicates an inverse relationship between total learning time and test performance<sup>s</sup> on test 11. In other words, those Midshipmen who spend the greatest total learning time for test 11 frequently score high on that test. On the other hand, the positive correlations of  $.89$ ,  $.87$  and  $.84$  between total learning time and scores on tests 72, 80 and 95 respectively show a strong tendency for Midshipmen using the greatest learning time for these tests to score low on them. It should be noted that only the correlations  $.89$  and  $.87$  are statistically significant. The remaining correlations are so low that it can only be concluded that in these instances there is little or no relationship between the variables, and the little relationship which exists is of an inverse nature.

In summary, it can be said that although a few strong relationships between learning time and test scores on some tests do exist, as has been noted in the above discussions, the majority of the correlations are low. Therefore, the only general conclusion which can be drawn for both groups is that except for a few instances there is little or no relationship between the two variables.

---

<sup>s</sup>The rank order for total learning time was from least to greatest with the student taking the least time having a rank of 1. The rank order for test scores was from high to low with the student making the highest score having a rank of 1.

#### 4.5.3 Midshipmen Who Completed the Course Six Weeks Early

It has been reported earlier in this paper that twelve Midshipmen, about 32 percent of the class, completed the Multi-Media Economics Course by December 9, 1969, approximately six weeks before the end of the semester, and that all twelve earned a final grade of A or B. This finding raises several questions concerning the characteristics of these particular students.

The first question which comes to mind is whether all the students who accomplished this feat were always among the group of Midshipmen who used the least total learning time per test. In the study of the latter group it was found that both the Midshipman who used the least total learning time to complete the course and the one who used the greatest amount were among the 12 who completed the course early. In addition to these two, three other Midshipmen who numbered among the group taking the least total learning time as well as four from the group taking the greatest total learning time, were among the twelve. Having students with such a wide range of learning time complete the course six weeks before the end of the semester leads to the conclusion that the students who work most slowly as well as those who work at faster speeds can complete both the core and enrichment learnings of the Multi-Media Economics Course in one semester or less. How long the student takes and his grade seem to be a function of how the individual student organizes his schedule and exercises his options in order to accomplish his own goals. Table 25 presents

the number of "early finishers" per control test in each group-- those taking the least total learning time or those taking the most. All five Midshipmen who required the greatest total learning time for test 27 completed the course ahead of schedule.

TABLE 25

Number of Midshipmen Completing the Multi-Media Economics Course Six Weeks Early Who Were Among the Groups Using the Least Total Learning Time (Group LLT) and the Groups Using the Greatest Total Learning Time (Group GLT) per Control Test, Fall 1969

<u>Test Number</u>	<u>Group LLT</u>	<u>Group GLT</u>
11T <sup>o</sup>	3	2
16P <sup>o</sup>	3	2
27T	2	5
39T	3	4
48P	2	4
61T	2	3
72T	2	2
80P	2	3
95P	3	4

<sup>o</sup>T = Unit test; P = Post test

Another question raised concerning the 12 "early finishers" is whether they consistently scored high on all tests. They were not, as a group, always among the Midshipmen making the highest scores. Eight of the 12 on some one of the tests were among those making the highest scores, while four of the 12 were in

the group making the lowest scores on one test or another.

Table 26 presents the information for each test.

TABLE 26

Number of Midshipmen Completing the Multi-Media Economics Course Six Weeks Early Who Were Among the Group with High Scores (Group H) and the Group with Low Scores (Group L) per Control Test, Fall 1969

<u>Test Number</u>	<u>Group H</u>	<u>Group L</u>
11T <sup>O</sup>	2	0
16P <sup>O</sup>	2	2
27T	2	1
39T	0	1
48P	1	1
61T	3	1
72T	0	1
80P	2	1
95P	1	0

---

<sup>O</sup>T = Unit test; P = Post test

To further investigate test performance, the mean scores of the 12 who finished early were compared with the means of the others in the class who finished at the end of the semester. The study shows a difference of one point in four of the tests and of only a fraction of a point in the other five tests, with the mean scores of the "early finishers" higher than those of the rest of the class in all but two instances (see Table 27). The one point difference in the means of the groups in the case of tests 11, 48 and 95 is statistically but not practically significant.

TABLE 27

Comparison of the Mean Scores of the Midshipmen Completing the Multi-Media Economics Course Six Weeks Early (Group I) and of the Rest of the Class Taking that Course (Group II) per Control Test, Fall 1969

<u>Test Number</u>	<u>Group I (N=12)</u>	<u>Group II (N=27)</u>	<u>Mean Difference</u>	<u>t-test</u>
11T <sup>o</sup>	36.6	35.6	1.00	2.3564*
16P <sup>o</sup>	28.4	28.1	.30	0.8315
27T	32.0	31.5	.50	0.8527
39T	40.3	40.6	-.30	0.4653
48P	47.0	46.0	1.00	1.3441*
61T	30.8	30.1	.70	0.6852
72T	33.7	33.8	-.10	0.3883
80P	45.3	44.3	1.00	1.0791
95P	33.6	32.3	1.30	1.9675*

<sup>o</sup> T = Unit test; P = Post test

\* P < .2

Two other comparisons of the group which completed the course ahead of schedule with the rest of the class were made. The first concerned the mean total learning time per test and explored the question of whether the mean total learning time of the group completing the course ahead of schedule is significantly different from that of the group finishing it at the end of the semester. For every test the mean total learning time for the early finishers is greater than that of the class (Table 28); however, none of the differences in mean total learning time is statistically significant. Although the mean difference in total learning time of more than an hour

for tests 48, 80 and 95 might have some practical significance, if it pertained to one segment, the fact that the hour or two difference represents only a few minutes additional time for each of some 20 segments (a whole Concept Area) lessens the practical significance of this finding.

TABLE 28

Comparison of the Mean Total Learning Time (Minutes) per Control Test of the Group of Midshipmen Who Completed the Multi-Media Economics Course 6 Weeks Early (Group I) and of the Rest of the Class (Group II), Fall 1969

<u>Test Number</u>	<u>Group I (N=12)</u>	<u>Group II (N=27)</u>	<u>Mean Difference</u>	<u>t-test</u>
11T <sup>o</sup>	391 (6'31")	366 (6'06")	25 (25")	0.6236
16P <sup>o</sup>	556 (9'16")	525 (8'45")	31 (31")	0.5038
27T	336 (5'34")	282 (4'42")	52 (52")	1.2667
39T	497 (8'17")	438 (7'18")	59 (59")	0.8611
48P	1152 (19'12")	998 (16'38")	154 (2'34")	1.0624
61T	328 (5'28")	291 (4'51")	37 (37")	0.8144
72T	443 (7'23")	421 (7'01")	22 (22")	0.3653
80P	1088 (18'08")	966 (16'06")	122 (2'02")	0.8189
95P	577 (9'37")	477 (7'57")	100 (1'40")	1.1986

<sup>o</sup>T = Unit test; P = Post test

The final comparison of the "early finishers" with the rest of the class concerns their QPR, SATV and SATQ scores.

Whether the mean QPR and the mean scores on the SATV and SATQ of the two groups are significantly different was examined. The findings show that in the case of all three variables the difference in the means of the two groups is neither practically nor statistically significant (Table 29).

TABLE 29

Comparison of the Mean QPR and the Mean SATV and SATQ Scores of Midshipmen Who Completed the Multi-Media Economics Course Six Weeks Early (Group I) and of the Rest of the Class (Group II), Fall 1969

<u>Index</u>	<u>Group I (N=12)</u>	<u>Group II (N=27)</u>	<u>Mean Diff.</u>	<u>t-test</u>
QPR	2.7	2.4	.3	1.4656
SATV	613	574	39.0	1.6485
SATQ	668	670	-2.0	0.1475

#### 4.5.4 Summary

Studies of the performance of the entire group of Midshipmen who were enrolled in the Multi-Media Economics Course, Fall 1969, as well as of the performance of subgroups, give conclusive evidence that the core materials of the course can be achieved by Naval Academy students in one semester or less at a 90/80 level of performance. Moreover, the results show that 90 percent of the students in the class complete additional enrichment material at an 85 percent level of performance within this same time period. Because of the self-pacing

feature of the course, students who require a greater total learning time than their classmates are able to complete the course in one semester or less, also. On the basis of these findings the course must be evaluated as highly successful in promoting efficient learning of economics by Midshipmen. These results also imply that the design of the instructional materials, which incorporates the sequencing of objectives, the conditions<sup>4</sup> suitable for the type of learning inherent in each objective, and the reinforcement of correct responses, is sound. Eliminating any part of the design could result in less spectacular performances by Midshipmen.

#### 4.6 Enrichment

In the Multi-Media Economics Course the Midshipmen along with their instructor determined the type and amount of enrichment the student would pursue. Many of the enrichment objectives were in a different domain (affective) from that of the objectives in the core (cognitive) and thus were beyond the scope of this contract. Among the enrichment activities were included seminars, readings, special projects and reports which afforded both the student and the instructor an opportunity to generate new objectives in the affective domain and include them in the contract. There were also a few validated instructional packages which showed the

---

<sup>4</sup>These conditions were outlined by Robert M. Gagné in The Conditions of Learning, New York: Holt, Rinehart and Winston, Inc., 1965.



instructor whether the student had achieved the associated instructional objectives.

The primary concern was whether or not the student elected to take enrichment and whether he completed it. The concern was with the affective element rather than with a predefined performance related to the content. The instructor was given the prerogative of assigning pass-fail weights to individual enrichment segments but within the bounds of the learning contract negotiated with the students. Therefore, an evaluation of the enrichment has not been included in this report. All formal instructional packages used in enrichment went through the same validation process as core material, and this has been documented in TR-5.39.

## 5. MEDIA USAGE

Throughout the Multi-Media Economics Course the Midshipmen can exercise various options concerning media. Three groups of core material segments have been prepared in an audio tape-workbook format as an alternative to the printed text. Although all enrichment is optional, there are choices of films, printed segments and computer simulations within the enrichment materials. Since a number of Midshipmen selected each of the media, the impact of each is discussed separately in the sections below.

### 5.1 Audio Tape-Workbook

The audio-tape-workbook segments are completely self-instructional, and the tapes, which run about 28 minutes, contain the same learning material as is in the printed segments. Interspersed throughout the taped explanation at appropriate points are references to the associated workbook which has the same diagrams, practice exercises, and self-test as the printed segments. Students choosing the audio tape-workbook format also used the student response board for recording their responses to practice exercises and self-tests, so that test data from the groups using different media for core materials are easily compared. The three series of audio segments have been designated Audio A (Segments 8-10, Concept Area I), Audio B (Segments 22-26, Concept Area II), and Audio C (Segments 43-46, Concept Area III).

No Midshipman was assigned audio tapes; anyone who used this format did so of his own volition. Most of those

who selected the audio reported they did so because they found tapes easy to understand and time-saving. Some also reported they preferred listening to reading, while others wanted a change in pace. Inasmuch as the same options were open to all Naval Academy students in the Multi-Media Economic Analysis Course, it may be assumed, then, that just by virtue of the fact they made this choice, those who elected to use audio are probably different from their classmates in some respect. They may prefer at times to learn through the sensory channel of hearing rather than of sight, or it may be that they have more curiosity. The difference could be attributed to any one or to a number of factors. Two Midshipmen chose all three groups of audio segments; two others chose two of the three groups; and all others selected just one group.

To determine whether any difference in QPR, SATV and SATQ scores existed between the students who used the audio and those who did not, the means of the two groups on each of these indices were compared using the t-test (Tables 30, 31, 32). The mean SATV score of the students selecting Audio A is 46 points lower than that of the rest of the class, a difference which is statistically and practically significant. Since this mean score is also 35 points lower than the mean for the class as a whole (Table 1), it might be concluded that students with SATV scores 30 points or so below the class mean will prefer audio. However, considering that this same phenomenon does not occur in the cases of Audio B (where the

one point difference in favor of those selecting audio is statistically significant), nor in Audio C, and inasmuch as the scores of the two students who consistently chose audio are at the class mean, there is not a strong case for such a conclusion. The same is true for the statistically significant difference of .25 points in QPR between the Audio A groups. All other statistical evidence shows no significant differences in the means of the group for any of the variables; therefore, it may be concluded that the groups are similar in these characteristics.

TABLE 30

Comparison of the Mean QPR and the Mean SATV and SATQ Scores of the Midshipmen Who Used Audio Package A and of the Midshipmen Who Used Comparable Printed Segments, Fall 1969

<u>Index</u>	<u>Audio A (N=10)</u>		<u>Printed (N=29)</u>		<u>t-test</u>
	<u>M</u>	<u>SD</u>	<u>M</u>	<u>SD</u>	
QPR	2.20	.30	2.57	.55	2.6561*
SATV	552	41	598	61	2.6330*
SATQ	668	51	670	56	0.1251

---

\*P < .2

TABLE 31

Comparison of the Mean QPR and the Mean SATV and SATQ Scores of the Midshipmen Who Used Audio Package B and of the Midshipmen Who Used Comparable Printed Segments, Fall 1969

<u>Index</u>	<u>Audio B (N=5)</u>		<u>Printed (N=34)</u>		<u>t-test</u>
	<u>M</u>	<u>SD</u>	<u>M</u>	<u>SD</u>	
QPR	2.26	.41	2.50	.53	1.2099
SATV	573	52	572	110	4.6417*
SATQ	685	44	667	56	0.7885

\*p < .2

TABLE 32

Comparison of the Mean QPR and the Mean SATV and SATQ Scores of the Midshipmen Who Used Audio Package C and of the Midshipmen Who Used Comparable Printed Segments, Fall 1969

<u>Index</u>	<u>Audio C (N=7)</u>		<u>Printed (N=32)</u>		<u>t-test</u>
	<u>M</u>	<u>SD</u>	<u>M</u>	<u>SD</u>	
QPR	2.46	.47	2.48	.54	0.0848
SATV	611	61	581	59	1.1861
SATQ	687	69	666	51	0.7635

Whenever a student chooses an activity, it is generally assumed that he does so because he likes it and that he will be motivated to perform at a higher level of competence than for an assigned one. However, it is possible for him to make the selection out of curiosity or for some other reason. If this is the case and the person finds he dislikes or is frustrated with his choice, his performance may deteriorate. In order to determine whether the audio tape-workbook format had any significant impact on the learning of the Midshipmen who opted to use it, the percentage of test items referenced to the objectives in the audio segments which were answered correctly by these Midshipmen was compared with the percentage of items referenced to the two segments preceding and to the two segments following the audio answered correctly by them. Prior to making this comparison, it was necessary to determine the difficulty level of the pertinent items on each test by means of an item analysis. The latter shows all items to be within the same range of difficulty, consequently, differences in performance within a test may not be attributed to the fact that some questions are more difficult than others.

The percentages of test items relating to objectives in either Audio A, Audio B or Audio C which the Midshipmen answered correctly are not significantly different, either statistically or practically, from the percentages of correct items referenced to objectives in the two segments preceding each of the audios (Table 33).

TABLE 33

Comparison of the Percentage of Correct Test Items Referenced to Objectives in Audio Segments with the Percentage of Correct Test Items Referenced to Objectives in Two Segments Preceding the Audio for Midshipmen Using the Audio Segments, Fall 1969

<u>Test</u>	<u>No. of Students</u>	<u>Non-Audio Items</u>		<u>Audio Items</u>		<u>t-test</u>
		<u>Segments</u>	<u>%</u>	<u>Segments</u>	<u>%</u>	
11T <sup>o</sup> (Audio A)	10	6,7	92.0	8-10	91.0	0.0834
16P <sup>o</sup> (Audio A)	10	6,7	87.2	8-10	90.1	0.2143
27T (Audio B)	5	21A,21B	95.6	22-26	91.6	0.2667
48P (Audio B)	5	21A,21B	80.0	22-26	85.6	0.2531
48P (Audio C)	7	41,42	94.0	43-46	88.6	0.3378

<sup>o</sup>T = Unit test; P = Post test

In some instances it was not possible to obtain data for the two segments immediately following the audio because they were part of a new concept area and were not included in the same tests as the audio; therefore, the comparisons are limited to Audio A and Audio B (Table 34). The percentage of correct test items referenced to objectives in the two segments following Audio B was significantly higher from a practical but not from a statistical point of view than the percentage of correct items referenced to objectives in the segments in Audio B. The fact that Segments 28,29 introduce a new topic may

have had a bearing on student performance, or the difference may have stemmed from the possibility that the content of Segments 22-26 is not especially well-suited to this particular format and does not promote a high degree of learning. We can only speculate as to the reason for the difference.

TABLE 34

Comparison of the Percentage of Correct Test Items Referenced to Objectives in Audio Segments with the Percentage of Correct Test Items Referenced to the Two Segments Following the Audio For Midshipmen Using Audio Segments, Fall 1969

<u>Test</u>	<u>No. of Students</u>	<u>Audio Items</u>		<u>Non-Audio Items</u>		<u>t-test</u>
		<u>Segments</u>	<u>%</u>	<u>Segments</u>	<u>%</u>	
16P <sup>o</sup> (Audio A)	10	8-10	90.1	12,13	97.3	0.6422
48P <sup>o</sup> (Audio B)	5	22-26	85.6	28,29	100.0	0.9434

<sup>o</sup>p = Post test

From the data on Tables 33, 34 it can be concluded that the Midshipmen who elected to use audio tape-workbook segments in general do not show great variation in performance from segment to segment, regardless of media used.

The next question investigated was: How does the percentage of test items, referenced to objectives in the audio segments which Midshipmen using the audio answered correctly compare with



the percentage of these same items answered correctly by the rest of the class? The difference in the percentages is not statistically significant (Table 35). Moreover, the difference is so small that it has no practical significance, and it may be concluded that students who opt to use audio tape-workbook format learn the objectives equally as well as the Midshipmen who use printed text.

TABLE 35

Comparison of the Percentage of Test Items Referenced to Objectives in Audio Segments Correctly Answered by Midshipmen Using Audio-Tape Workbook Packages (Group I) and Those Using the Printed Texts (Group II), Fall 1969

<u>Test</u>	<u>Group I</u>	<u>Group II</u>	<u>t-test</u>
11T <sup>o</sup> (Audio A)	91.0 (N=10)	90.8 (N=29)	0.0192
16P <sup>o</sup> (Audio A)	90.1 (N=10)	89.9 (N=29)	0.1667
27T (Audio B)	91.6 (N=5)	95.6 (N=34)	0.3175
48P (Audio B)	85.6 (N=5)	85.7 (N=34)	0.0064
48P (Audio C)	88.6 (N=7)	93.9 (N=32)	0.3942

<sup>o</sup>T = unit test; P = post test

Although the tapes generally have a 28 minute playing time, some run about three minutes less. The playing time of the tapes should not be confused with learning time. The total

learning time for an audio segment includes not only the time used in listening to the tape, but also the time required for completing the practice exercises and the self-test plus the time for any replaying of the tape which the individual might find necessary. Was the total learning time of the Naval Academy students with the audio tape-workbook packages greater than that of others in the class? For Segments 8-10 (Audio A), Midshipmen using the audio tape-workbook format required on the average 17 minutes less total learning time than those using the printed text (Table 36). This difference is statistically significant because there is a wide range of total learning time within the latter group. However, the students using the tapes for Audio B (Segments 22-26) on an average used 20 minutes more than the rest of the class, but this difference is not statistically significant. The mean difference for Segments 43-46 (Audio C) is only eight minutes, with the audio requiring less time. For the student who uses all the audio segments, the differences would almost strike a balance; but on the whole, he would probably take a little less learning time with these than with the regular materials. However, the majority of the Naval Academy Midshipmen used only one audio package; therefore, the fact that the mean learning time for those using Audio B is 20 minutes longer than the mean time for the users of the regular segments could have some influence on the decision of Midshipmen interested in selecting audio.

TABLE 36

Comparison of the Mean Total Learning Time (Minutes) for Midshipmen Using Audio Tape-Workbook Package (Group I) and for Those Using Printed Materials (Group II) for Segments Prepared in the Two Media, Fall 1969

<u>Segments</u>	<u>N</u>	<u>Group I</u>		<u>Group II</u>		<u>t-test</u>
		<u>Mean</u>	<u>SD</u>	<u>Mean</u>	<u>SD</u>	
8-10 (Audio A)	10	144 (2'24")	22 (22")	161 (2'41")	41 (41")	1.7231*
22-26 (Audio B)	5	155 (2'35")	61 (1'01")	135 (2'15")	52 (52")	0.6923
43-46 (Audio C)	7	115 (1'55")	25 (25")	123 (2'03")	46 (46")	0.7060

---

\*P < .2

The findings reported above lead to the conclusion that the use of audio packages did not have an appreciable impact on the learning of the objectives in those segments, for the performance of the Midshipmen selecting these did not vary significantly from segment to segment. On the other hand, the students with the audio learned the objectives equally as well as those who studied the printed segments and in somewhat less total learning time.

## 5.2 Films

Films used in the Multi-Media Economic Analysis Course were reproductions of a few of the lessons from The American Economy, a TV course in economics. Each one contains information which has direct bearing on specific objectives in the Multi-Media Economic Analysis Course. The films really serve a dual purpose: to introduce a topic or to review it. Questions referenced to each objective in the film were prepared for distribution at the beginning of the film period to direct the attention of the students to the relevant material. After the film had been shown, the students were to answer the questions as a self-test. However, several logistics problems arose in connection with the showing of the films (these will be discussed in a later section of this report), and the routine designed for showing films and giving questions was not actually followed. Nevertheless, in an attempt to determine what effect, if any, the films had on the learning of the specific objectives discussed in them, a comparison was made of the mean performance of viewers and non-viewers on test items referenced to those objectives. The results are given in Table 37.

Although the t-tests indicate statistically significant differences for items in three tests, in two of them, the difference is a fraction of a point and has no practical significance. In the case of test 27 the difference of one point in favor of those seeing the films has practical significance, because getting credit for that one item might spell the

difference between passing 80 percent or more of the objectives and being able to go ahead in the course, or passing fewer than 80 percent and having to stop for review.

TABLE 37

Comparison of the Mean Scores on Test Items Related to Films for Midshipmen Who Viewed the Film (Group I) and for Those Who Did Not View Them (Group II), Fall 1969

<u>Test and Film</u>	<u>N</u> <u>I,II</u>	<u>Group I</u>		<u>Group II</u>		<u>t-test</u>
		<u>Mean</u>	<u>SD</u>	<u>Mean</u>	<u>SD</u>	
16P <sup>o</sup> (10M)	34,5	2.8	.43	2.6	.55	0.6438
27T <sup>o</sup> (21M)	29,10	13.0	.87	12.1	1.40	1.6270*
39T <sup>o</sup> (38M)	30,9	9.4	.68	9.8	.67	1.2216
48P (42M)	32,7	5.1	.66	5.6	.53	1.9136*
72T (65M)	26,13	2.0	.00	1.8	.38	1.4771*
72T (70M)	30,9	4.9	.43	4.9	.33	0.1628

\*P < .2

<sup>o</sup>T = unit test; P = post test

### 5.3 Computer Simulations

Running computer simulations of economic systems is another optional enrichment activity in the Multi-Media Economic Analysis Course. There are eleven such simulations, and some of them are designed to challenge the most advanced first-year student.

Six Midshipmen elected not to work any of the simulations; others in the group worked various numbers of them, but no one worked all. No conclusions can be drawn concerning the effectiveness of the simulations, since the computer was usually down when a student was scheduled to run a simulation. With down time rates reportedly running as high as 80 percent for some students, students typically had to replan their schedules several times in order to run one simulation.

## 6. STUDENT AND INSTRUCTOR ACCEPTANCE

### 6.1 Reaction to the Course, as a Whole

Student acceptance of the Multi-Media Economic Analysis Course has been overwhelmingly favorable each semester the course has been given. The main reason for the favorable reaction is the self-paced aspect which eliminates the necessity of attending regularly scheduled class sessions and gives each Midshipman full responsibility for his own learning. Every Naval Academy student who took the course indicated on the "End of Course Critique" that the learning efficiency (the amount of information learned per unit of time spend) in this course is greater than that in the traditional lecture course. Although the instructor continues to like the lecture method and recommends that some topics in the course receive less emphasis and that new topics be included, he is highly complimentary of the Multi-Media Economic Analysis Course because the students in it learn economic theory easily and well. He also likes the freedom which the

release from meeting regular classes gives him to work with individuals and small groups. He suggests that there should be seminars to help the students see the relationship between economic principles and current problems. His enthusiasm for the course grows as he becomes more familiar with the new role which the instructor in the Multi-Media Economic Analysis Course must assume.

Student reaction to the course has been checked throughout the semester by means of a Student Critique sheet which the Midshipmen were asked to fill out upon the completion of each test. Since response was voluntary, not every student returned a critique after each test, but about sixty percent replied each time. The results have been summarized by test and are included in Appendix 4. In addition to commenting on the course each test period, the Midshipmen upon completing the course turned in an "End of Course" critique, and those who selected the audio tape-workbook format for any segments made an appraisal of them. Summaries of all responses given on these forms may be found in Appendix 4.

It is appropriate at this point to compare responses given to questions on the test critiques with those given to questions posed on the "End of Course" critique. The total number of responses to the test critique sheets is 284, to those at the completion of the course, 39. Although the questions on both are not exactly the same, they concern the same general areas, so that there is a validity check.

When asked on the test critique about the level of difficulty of the materials in the economics course, the Midshipmen checked that it was neither too easy nor too hard in 91 percent of all responses. Three percent of the responses given indicated that it was too easy, and four percent that it was too hard. At the end of the course about 70 percent of the Midshipmen reported they had never referred to one of the standard texts for additional explanations (detailed references to pages were provided in the materials), and 60 percent had never consulted their professor for help with any part of the course. Twenty percent had studied standard texts less than an hour, and about 26 percent had had half-hour conferences with the professor to obtain help with some special difficulties. All these facts seem to substantiate the conclusions that the course content is neither too easy nor too hard for the Midshipmen and that the materials are indeed self-instructional.

In all instances where the Midshipmen were asked to compare the approach of the Multi-Media Economic Analysis Course with traditional approaches, the students registered a decided preference for the self-instructional method of the experimental instructional program. Only one percent of the total replies on the test critiques showed a preference for the lecture method. Two students (less than one percent of the class) checked that the experimental program was less valuable than the lecture method, while fewer than ten percent checked that the two approaches had about the same value for them.



On the "End of Course" critique the Naval Academy students were asked to make suggestions for improving the Multi-Media Economic Analysis Course. Twenty-two, or about 60 percent, asked that the course be made more relevant to present day economics policies and problems through occasional non-mandatory seminars, discussions, lectures or films (which, incidentally, are included in the course plan). Analysis of the test critiques shows that only three students indicated that they wanted class discussions, and these three repeated their request on several of the critiques. Only once or twice was relevancy mentioned on the test critiques; however, the fact that over half the students suggested this at the end of the course indicates that upon looking back over the course as a whole, they recognized a need for this type of activity. The lack of such activities is not the fault of the design of the course, but rather of the way in which it has been implemented. In the course plan, there are opportunities to have seminars, and some segments (e.g., 47, 57, 71, 99) have been set aside for such activities. Thus, since the course plan anticipates and encourages such activities, it would be possible within the scope of the course to act upon the request of the students.

Although throughout the course eleven students mentioned repeatedly that there should be more periods scheduled for test taking, only six suggested this at the end of the course. Five Midshipmen suggested revising the computer simulations, yet twenty-three indicated they had

to spend time with the professor because of procedural difficulties with the simulations. During the first few weeks of the course, fourteen Midshipmen said they disliked the student response board. However, after Concept Area II, no one mentioned the student response board,, and on the End of Course critique only one person suggested eliminating it. There were other suggestions, such as having more audio and having more test questions on enrichment which were mentioned by only one or two students. All of these are recorded in Appendix 4.

There was no opportunity on the End of Course critique for the Midshipmen to note what they liked best about the economics course; however, on the test critique, as mentioned before, the self-pacing aspect was mentioned not only most frequently but by 80 percent of the students at one time or another. Six of those who said the self-pacing aspect was the best thing about the course also wrote that their tendency to procrastinate and to put off studying until the last minute was one of the things they liked least about the experimental course! Many commented that they liked the clear, concise format, but others sometimes found the explanations wordy and a few became bored with the sameness of the format. Some disliked one thing, while others liked it; however, the course as a whole has been most favorably received by both the students and the instructor.

## 6.2 Reaction to Films

A section of the End of Course critique was devoted to the Midshipmen's reactions to films. Their answers were somewhat conflicting and indicate that both the films themselves as well as the question of whether they should be retained in the course should be reviewed. For example, 27 Midshipmen answered that the films were effective as a supplement to make the course relevant and interesting; yet, 23 of them wrote that they found the films boring and a waste of time. Just as many students mentioned that the films were too long, and poorly constructed as said that they were realistic, relevant, clear, good presentations of economic concepts. There is a dichotomy of opinion which leads to the conclusion that the whole question of films should be reviewed.

## 6.3 Reaction to Audio Tape-Workbook Segments

Forty percent of the students used at least one of the audio tape - workbook series. Two students elected to use all three series, and four chose two. Only two of all the Midshipmen who selected the audio packages did not finish the segments using tape medium. These two returned to the printed version, and reported that they were spending much more time learning by audio than by reading because they could not concentrate on economics when listening to the tapes. A few Midshipmen liked the audio because they could do other things, e.g., polish shoes, while listening to the

tapes; however, this was not the typical reason for liking the audio packages. About 80 percent were favorably impressed by this medium because it made learning easier for them and provided a stimulating variety in learning. They also indicated they would like to see more audio options in the course.

Adverse criticisms included those mentioned earlier in this section and the fact that it was difficult to go back over materials when using tapes.

In spite of the fact that the audio tape-workbook packages were not widely used by the Midshipmen, they did fill a need for those students who prefer to learn using auditory senses, and they also provided a change of pace in the course. Probably more audio packages should be included in the course, but the question of what kind of content is most suited to this treatment should be investigated before making any additions or changes.

Although some of the Midshipmen became weary of filling out critique sheets, they were on the whole very faithful in performing this task, and their suggestions and comments concerning what they did not like were candid, circumspect and valuable.

## APPENDIX A

Excerpts from TR-5.37

(This appendix consists of:  
pages 4, 5, 6, 7, 8, 9, 10,  
11, 12, 13, 14, 15, 16, 17  
of TR-5.37.)

employed in the analysis is described in a brief, non-technical form in Appendix D and, in more detail in Appendix B.

Our use of the term "validation," then, appears to correspond to the term "evaluation" as described by Stolurow and employed by Brennan.

In our planning activities we tend to think of validation as a task that precedes "evaluation." We have viewed validation as being primarily concerned with the instructional effectiveness of the course. On the other hand, we have looked upon evaluation as being the process of assessing the interactive effects of the new course and its administrative-operational environment, including the acceptability of the course and its component parts to faculty and students involved in course activities. This "evaluation," of course, includes key aspects of the validation process. As in the validation activities, student performance data must be obtained. Accordingly, student achievement is measured in terms of data gathered with criterion-referenced pre and post tests, and data are obtained on the amount of study time taken. However, the focus is on the question of how well a highly individualized learning program can fit within an existing, conventional administrative-operational environment. Regardless of the instructional effectiveness of the course, an acceptable "fit" must be found if the course is to continue to function at the Academy.

In summary, our use of the term "validation" seems to be comparable to Stolurow and Brennan's use of the term "evaluation." As used in this report, "evaluation" refers to the process of determining the degree of fit between a fully operational, highly individualized course and its administrative-operational environment.

### III. Basic Methodological Considerations

In the fully operational economic analysis course, as it is currently designed, students will be able to proceed through the course at their own pace, make many of their own decisions on media usage and optional enrichment areas, and otherwise exert a significant degree of control over when and how they study. In other words, the course is highly individualized in its intended operational state. It is very desirable that the course be evaluated in that highly individualized state.

A methodological problem can arise if one wishes to perform controlled media research during the "evaluation semester." An experimental design necessarily calls for extensive control of variables. And only when an experiment is carefully controlled are its results of value. The type of control generally required, however, is directly at odds with the concept of a highly individualized course. The very essence of a highly individualized course--the flexibility and options--presents the problem. It is possible to be faced with the alternative of either conducting a carefully controlled experiment or evaluating a highly individualized course of instruction.

Media studies conducted in the past have been particularly guilty of following neither alternative well. In his review of instructional design and media selection factors, Saettler (1968) points out that the predominate type of media study conducted has been the media comparison study, usually yielding a finding of no significant difference. He concurs with the observations by Knowlton (1964) that these studies were not actually research on media because their experimental designs did not provide for separating the physical characteristics of the media from the sign vehicles of the message they carried. Lumsdaine and May (1965) and Lumsdaine (1963) in their reviews of media research have stressed the inherent limitations of such studies.

In the present case, it is of critical importance that the evaluation apply to the course as it will be operating in the future. Any media studies conducted during the evaluation semester should disturb as little as possible the intended course operations. Only then will the results of the evaluation be useful. And of course, the results of media studies which do not disturb the normal operations will have greater value for a curriculum development model than studies conducted in a temporary artificial atmosphere.

One last point should be made regarding evaluation methodology. There is usually a "shakedown" period after a new system is first placed into full operation. During this period, it may become necessary to modify the system slightly



to overcome an unexpected problem. The previous tryouts of the economics course have tended to validate its subsystems and its plan of operation. The shakedown period for the operational course will be the evaluation semester, which begins in September, 1969. The evaluation methodology must be such as to permit necessary changes to be made in the administration of the course during this period.

#### IV. Evaluation Approach

Evaluation activities may be described as falling into four basic categories:

1. Student performance
2. Student and Instructor acceptance
3. Course management
4. General operational environment

The ultimate measure of the success of a learning program is, of course, the performance of the students in achieving the learning objectives. However, the other three categories of activities listed above are important in facilitating or hampering the achievement of the desired performance. Each of the four categories is discussed below in terms of objectives, data required, method of data collection, and data analysis. It is assumed that a randomly selected student group of between thirty and forty students will take the course and that all of the selected students will be in their third year at the Academy and have had no previous course in economics in college or high school.

## A. Student Performance Evaluation

Purpose: The primary purpose of this area of evaluation is to determine the efficiency of instruction. Efficiency is measured in terms of learning-time-taken and achievement scores on criterion-referenced examinations.

Data Required: Two classes of data are required.

1. Achievement scores on criterion referenced examinations, for each student on each control test
2. Amount of learning time taken by each student on each instructional segment.

Method of Collection: The criterion-referenced control tests will be administered to students by the course administrator in the area provided for such testing. A student will be permitted to take such a test as soon as he believes he can pass it. If he fails to achieve criterion performance in two tries, he will be required to see his professor, who will make a diagnosis and individual learning prescription. This arrangement should deter students from taking criterion tests more than once, without having studied, in the hopes they might pass some by chance. It should also serve to identify early the students who may have a serious learning problem which needs the diagnostic skills of the instructor. The final achievement score obtained by a student on a control test will be used as the measure of his "performance."

Time-taken will be recorded on a segment-by-segment basis by each student and he will submit his study time record to the Course Administrator at the time he takes a control test. The total study time accumulated prior to the student's passing the control test will constitute his learning time-taken for the level of achievement he obtained as indicated by his test score.

Data Analysis: The data analysis will include the following:

a. Group measures

1) Group achievement per control test

- . range
- . mean
- . median

2) Group study-time-taken per control test

- . range
- . mean
- . median

3) Average study-time-taken of bottom and top five achievers

4) Average achievement of five slowest and five fastest students in regard to study-time-taken

b. Individual measures

1) Achievement on individual control tests

2) Relative standing on achievement tests

3) Average time-taken per segment

4) Relative standing in time taken

## B. Student-Instructor Acceptance Evaluation

It is important to take into account the attitudes and opinions of the students and the instructors involved in the multi-media course. Provided the course is effective from an instructional learning standpoint, it becomes important that the course is "acceptable" to those who are involved in it as instructors or students. There are different levels of acceptance, ranging upward from barely tolerable. The key level of acceptability is the level at which a student or instructor would be willing to continue with a course such as this in the next semester.

Purpose: The purpose of this evaluation area is (a) to ascertain if students and/or instructors are willing to continue in a course designed as this one, and (b) to determine what aspects of the course might be changed to increase the acceptability while meeting the learning objectives.

Data Required: Students' and instructors' comments on specific aspects of the course, as well as the course in general, will be solicited. The specific aspects of the course on which comments will be solicited will include each media-materials combination and other planned instructional activities.

Method of Collection: Critique sheets will be issued with instructor materials and student materials and will otherwise be made available to the instructors and students. These sheets will be sufficiently structured so that information will be solicited regarding specific and general aspects of the course. However, the reply requested will be "open-ended," so that no restrictions are placed on obtaining possible negative comments.

Data Analysis: Critique sheets turned in for evaluation purposes will be subjected to an analysis to determine (a) what aspects of the course were reported as best liked and (b) what aspects were negatively criticized. Absence of a negative response on an aspect of the course will imply that that aspect is acceptable. The specific negative and positive comments can serve as the basis for revising the course administration to increase the general level of acceptability.

### C. Course Management

The course management concerns instructor-student-media-materials logistics, schedules, learning prescriptions, and other aspects of providing for and monitoring instructional activities. Course management planning is done by the instructors within the context of previously established course management policies and procedures.

A course Administrator will be responsible for administering the plan (though he will perform no instructional or guidance function). Effective course management is crucial to the success of a highly-individualized, self-paced program.

Purpose: The purpose of this evaluation area is to assess the adequacy of the course management plan and its administration and to ascertain what improvements might be made.

Data Required: Information on problems that arise regarding course management is needed. This information should include a description of the problem, the date it first was detected, the circumstances under which it arose, what was done about it, who was involved, and what future action seems advisable.

Method of Collection: The multi-media course instructors, the course administrator, and the liaison personnel of the contractor will be given a notebook and instructions for recording critical incidents.

Data Analysis: The various notebooks will be brought together for an analysis of the events recorded. A determination will be made of what action, if any, should be taken for each negative event recorded, to prevent its reoccurrence.

#### D. General Operational Environment

A highly individualized instructional program cannot be designed without regard to the constraints that may be imposed by the general environment in which the program will be carried out. Similarly, such a course cannot be successfully introduced into a conventional educational environment without the environment being changed to some extent. The "environment," as used here, refers to policies, procedures, staffing, facilities, and similar factors that constitute the situation within which the program, or course, operates.

Several examples may be given of the kinds of "conflicts" between the old and new often created by introducing such a course. A grading policy may have been established only after long and careful deliberation, but when are mid-term grades submitted if a program is self-paced and students are at many different places in the course? Similarly, a media-materials resource center has a set of new requirements to meet when it must serve a highly individualized, multi-media course.

Purpose: The purpose of this area of evaluation is to assess the effects of the course on the operational environment and the effects of the environment on the operation of the course. This will provide information regarding what changes in the course or its environment might be advisable to further the learning goals.

Data Required: Information regarding conflicts between the multi-media course and its operational environment is necessary. This information should include a description of the conflict, the date it was first detected, its implications, what was done about it, and what future action seems advisable.

Method of Collection: The multi-media course instructors, the course administrator, and the contractor liaison personnel will be given a notebook and instructions for recording operational conflicts.

Data Analysis: The various notebooks will be brought together for an analysis of the events recorded. Recommendations will be made about what action, if any, should be taken to eliminate course-environment conflicts.

## V. Special Media Analyses

The special media analyses tend to fall into two categories, one concerning alternate media and one concerning the cumulative effects of the media configurations used by individual students. The primary value of the data gained by these analyses is to (a) produce insights into instructor-student-media-operations interrelationships and (b) produce hypotheses which may be tested in subsequent research activities at the Naval Academy or elsewhere.

### A. Alternate Media

There are two classes of alternate media in the course that are amenable to a comparative assessment.\*

\* The term "assessment" is used because of the judgmental factors that will enter into the comparisons. The complexity of the situation within a fully operational course does not permit the control of variables that would be desired in a "true" experimental design.



One class is the self-instructional packages. There are both self-instructional audio packages and self-instructional printed packages prepared for certain instructional topics. It would be possible to compare the success of students who use the alternate medium, for the same instructional content and behavioral objectives. The questions of concern are (1) whether or not some students like to learn in a situation like this, using one sensory channel as opposed to another, and (2) whether or not some students do learn better, in situations like this, using one sensory channel as opposed to another.

The second class of alternate media which should permit a reasonably acceptable comparative assessment to be made concerns the economics simulation models. Certain models may be presented in two ways, one which uses the computer and one which does not. In the case where the computer is used, the student can manipulate the model as many times as he wishes in order to see what effects are produced. In the alternate case, without the computer, the student would get a learning package, a key part of which would be the computer printouts showing the effects produced when variables are manipulated in certain ways. The question of concern would be whether or not it was necessary for students to actually manipulate a simulation model at a computer terminal in order to benefit from the simulation approach used in this course.

One must resist the impulse to require certain students to use certain media simply to insure that an adequate sample of students use each alternate media. Not only would this be incompatible with the objective of a fully operational course, but the net result might be to produce a general negative effect on course activities and achievement. However, it would seem appropriate to (a) accept volunteers for each of the alternate media and (b) where a student is not doing well, generate a prescription for an alternate media. Our records, of course, would note whether a given alternate medium was prescribed or the student volunteered. Given a student group of about forty, it would seem reasonable that at least twenty-five percent of them would use each alternate medium under these circumstances.

Data Required: Achievement scores on criterion-referenced examinations, media used, whether media were selected voluntarily or prescribed, time-taken per segment, and media "acceptance" results, for each student.

Method of Collection: All of the data required will be obtained as part of the evaluation activities described in section IV of this report.

Data Analysis: Students will be grouped according to the alternate media they used. An analysis will then be made of the characteristics of the students who (a) perform better using one medium than the other and (b) perform

relatively better than other students on a single given medium. The characteristics that will be employed in the analysis include a student's SAT-verbal score, his SAT-math score, whether or not the alternate medium was used by him voluntarily, and the student's achievement in other areas of the course.

#### B. Cumulative Effects

Each student's media-usage in the course could differ from that of other students. The effects of a given sequence of media usage may be cumulative. For example, we may find that certain media-usage patterns produce an increasingly rapid rate of learning throughout the course. Conversely, some media, after prolonged use, may tend to induce boredom. We may find that certain media have a "halo" effect, either positive or negative, on general achievement in the course.

Data Required: Achievement scores on criterion-referenced control tests, study time-taken, and media usage, for each student.

Method of Collection: All of the data required will be obtained as part of the evaluation activities described in section IV of this report.

Data Analysis: The media-usage of individual students will be analyzed to determine if any media-usage patterns can be found to account for differences in performance levels, and performance trends. As used here, "performance" refers to achievement and time taken by the student.

APPENDIX B  
Excerpts from TR-5.39

(This appendix consists of:  
pages 2, 3, 4, 5, 6, 7, 8, 9, 10  
& 15 of TR-5.39; pages 20-27  
of same report.)

## 2. Population and Limitations to Data

The Multi-Media Economics Course was validated during the spring of 1969 on two groups, one made up of 31 Midshipmen enrolled in two of the Economic Analysis classes at the United States Naval Academy and a second consisting of 10 male students from various universities in the Washington area who came to the Educational Technology Center of Sterling Institute to take the course. The individuals comprising the latter group were chosen because of their similarity to the Midshipmen in various characteristics. (See Appendix A.)

Although it was not possible to obtain a QPR for the in-house group, the individual SAT Verbal and SAT Quantitative Scores were available. The means of the two groups in each of these tests were compared using a t-test. The data in Table 1 indicate that the mean SAT Verbal scores of the two groups were not significantly different; however, the mean SAT Quantitative scores of the group were significantly different, the Midshipmen having a mean score approximately one standard deviation above the in-house group. Although the two groups were from the same population from the standpoint of SAT V performance, they were not from the same population from the standpoint of SAT Q performance. The difference in quantitative scores may have some practical significance for student performance in Concept Area III of the economics course and will be discussed later.

TABLE 1

Comparison of the Mean SAT Verbal and the Mean SAT Quantitative Scores of USNA and In-House Students

<u>Test</u>	<u>USNA Mean</u>	<u>In-House Mean</u>	<u>df</u>	<u>t</u>
SAT V	589	632	35	1.7125
SAT Q	674	590	35	3.710*

\*P < .01

The data used in this report were collected using student response boards which produced punched cards (informally referred to as "Dymedia cards"). This data collection process is described in Appendix B.

At least ten Educational Technology Center (ETC) in-house student-subjects completed all of the major concept areas of the course, with the exception of the last concept area. Concept Area IV represents about 10% or less of the course. Ten

students from the original sample completed Concept Area III, but for an assortment of reasons (none of them related to the experimental course) only two could be present to complete Concept Area IV.

Several junior members of the staff of the Educational Technology Center, who had no previous knowledge of economics, also completed the course, including Concept Area IV. The data generated by these junior staff were used as informal additional information during the preliminary tryouts. Since these data were informal in nature, they are excluded from this report.

While the key information in this report concerns the performance of the Midshipmen during the tryout of the course at the Naval Academy, there are a number of reasons why information on the in-house tryouts may be of interest to the reader. Accordingly, data on in-house tryouts are given, and often in the same table as comparable data from the tryouts at the Naval Academy.

In reviewing such data, particularly if one wishes to make comparisons, it must be understood that the Midshipmen were presented with a revised version, in the case of many instructional segments, of what was used by the in-house students. Moreover, some in-house students received a revised version of what other in-house students had tried. For example, five students might try an instructional segment, which was then revised before the five other students were permitted to try it. The data from these tryouts by in-house students were grouped together in this report for the convenience of the reader. Thus, a mean score for a test would be based on the actual scores of ten students, though some of the students were subjected to a slightly different version of instructional materials.

While the N of the in-house students showed a rapid decline for the last part of the course, the N for the Midshipmen remained the same throughout the tryout at the Naval Academy. On the other hand, while data collection activities where in-house students were involved could be controlled, certain data collection activities insofar as Midshipmen were concerned were beyond complete control and minor data gaps occurred.

Midshipmen were required to turn in literally hundreds of Dymedia cards. Such cards were used to capture their responses to learning-embedded tests, self-tests, and various kinds of unit tests, pretests, and post-tests. At various points, some cards were lost and others were improperly filled out so that data could not be identified or otherwise used. Some students also found it difficult to remember to record their study/learning time.

In the case of tests, it was not possible to ascertain whether the student had actually studied all the material before taking a segment, unit, or post test. Also, it is highly unlikely that all students followed the prescriptions and thoroughly reviewed course materials prior to taking a make-up test, since scores on the make-up tests in some instances were not different from the original scores.

The tests for Concept Area IV were scheduled during final exam week, so that students had no time for make-ups. In addition, one class was told that Post Test 95 (the post test for Concept Area IV) would not count, and would not affect the students' grades. Consequently, these data defy interpretation, for whether scores reflect an effort comparable to that exercised in other areas or whether they represent just guesses cannot be determined.

Despite these deficiencies, the data available are meaningful and demonstrate that the Multi-Media Economics Analysis Course was an effective instructional system during the spring semester of 1969.<sup>1/</sup> This document reports the findings of an analysis of the available data.

### 3. Validation of Course Materials

#### 3.1 Content Validity

In determining the validity of the instructional materials, one of the first questions to be answered was: Is the subject matter of the course compatible with that which is usually taught in courses of "Economics" or "Principles of Economics"? The answer to this question called for extensive use of expert opinion in the development and writing of the materials, and also in the revision of materials.

The economic content of the materials used in the Multi-Media Economics Course was written by approximately twenty experts in the field of economics, including professors of economics on the staffs of universities in various parts of the United States, as well as economists associated with governmental or private institutes in both the United States and Canada. Following the tryouts, revisions of the materials were written by an economist employed full-time by Sterling Institute.

---

<sup>1/</sup> The course was revised during the summer of 1969, based on the detailed empirical data produced in Spring Semester tryout.

Although the materials were the original work of each economist-writer, they were referenced to two well-known texts in economics, Economics<sup>2/</sup> by McConnell and Economics<sup>3/</sup> by Samuelson. The Multi-Media Economics Course differs from the two texts most markedly in the arrangement of topics and in presentation, and not in economic content. In these two ways, then, by comparison of the economic content of the Naval Academy course with the content of the two most widely-used textbooks in the field and by review of subject matter experts the content validity of the course materials was established.

### 3.2 Student Performance - Number of Core Objectives Learned

Validation also refers to those activities which were designed to determine whether the instructional materials, procedures and techniques produced the expected changes in behavior in the students at the United States Naval Academy of the kind and level anticipated. In other words, validation of the course materials, procedures and techniques rested on the answer to the question, "Have the students learned?" or even more specifically:

1. Have 90 to 100 percent of the students learned 75 percent of the core objectives?
2. Did this learning represent a significant increase in knowledge over that which was known prior to studying the materials?
3. Has this learning been accomplished in one semester?

Student performances on various tests given at specified intervals during the course have provided the data from which the answers to the above questions have been derived. Throughout the course the students checked their own learning by means of self-tests which were included in the self-instructional package at the end of each segment. At predetermined points in the course, pretests, unit tests, and post tests were administered in order to assess the individual's progress and to diagnose his difficulties. It may be of value at this point to summarize briefly the structure and kinds of tests used in the economics course.

<sup>2/</sup> Campbell R. McConnell, Economics, New York, McGraw-Hill Book Company, 1969.

<sup>3/</sup> Paul A. Samuelson, Economics, New York, McGraw-Hill Book Company, 1967.



### 3.2.1 Segment Self-test

Whenever the student completed studying the economic content of a segment and the solving of the problems embedded in that content, he took the short, self-administered, multiple-choice test which accompanied each segment. Each question was referenced to one of the objectives which he had just learned; every objective discussed in the segment was represented. Whenever he chose an incorrect response, he checked the prescription given with the test for suggestions for obtaining additional information related to the particular objective he had not learned. Although the segment self-test was not graded, it provided each student with immediate feedback concerning how well he had learned a group of concepts and gave him the opportunity for remediation, if necessary. Each student turned in his records of performance which were used in the revision of materials. (See Appendices A, B, C.)

### 3.2.2 Unit Test

At predetermined intervals in the course, the student was graded on his performance on a unit test which included questions referenced to some but not all of the terminal objectives for a group of segments, as well as questions referenced to some of the enabling objectives subsumed under each terminal objective. (See Figure 1.) Since the course content was written in hierarchical arrangement as in Figure 1, it was assumed that when a student passed an item referenced to a terminal such as 2571, he had learned the enabling objectives leading to it. For example, if he passed the item related to terminal Objective 2571, but failed one of the enabling objectives, either 2568 or 2538, it was assumed either that the student had made an educated guess in answering the question related to terminal Objective 2571 and needed to study further the materials for Objectives 2568 or 2538, or that the course materials were not effectively producing learning and needed revision. Students who answered correctly fewer than 90% of the items on a unit test had to take an alternate form (Z) of the test as a make-up. The Z form of the test contained new items referenced to the same objectives as occurred on the original test.

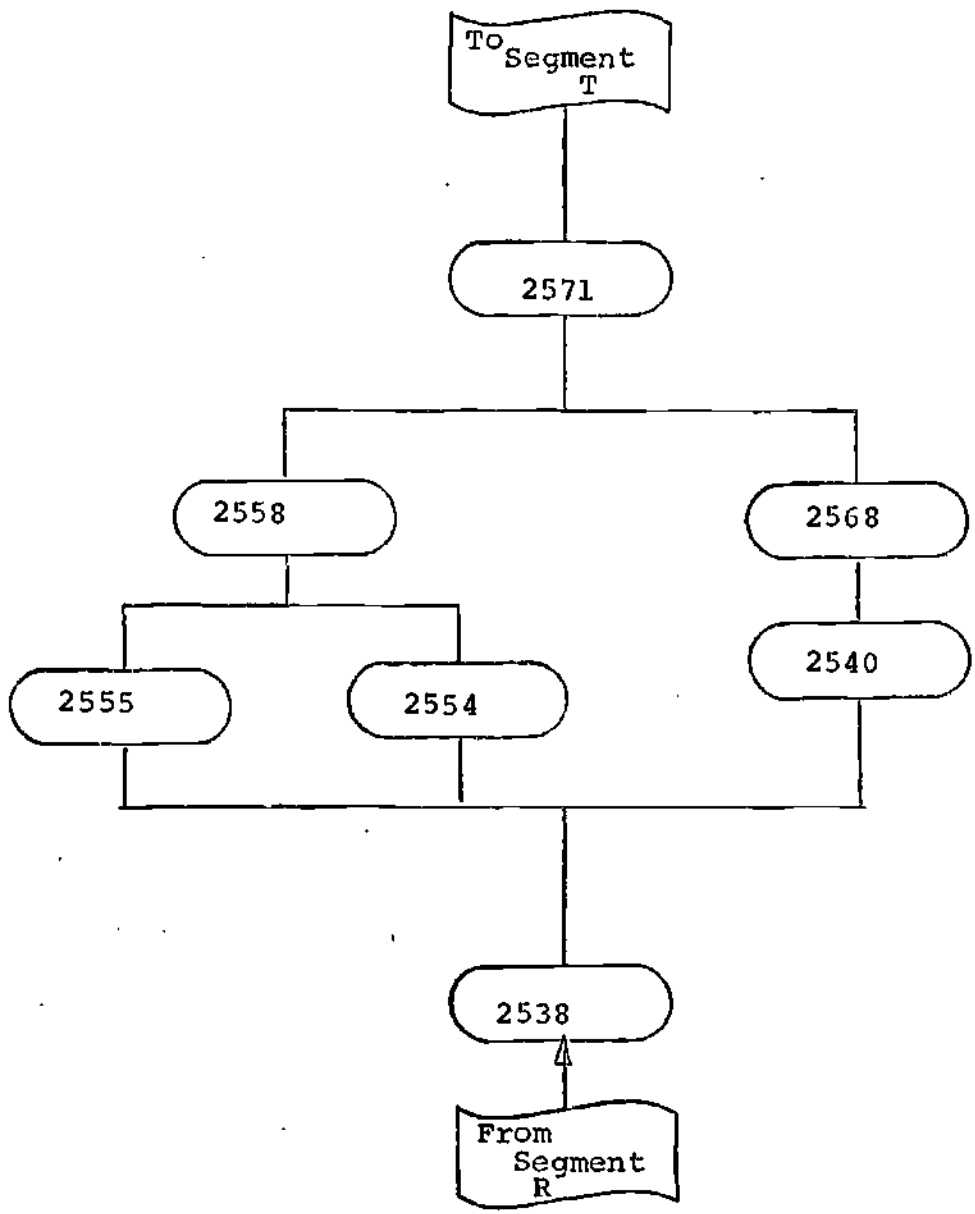

**Fig. 1** - Hierarchy Chart for Hypothetical Segment S Showing Terminal Objective 2571 with its Enabling Objectives

### 3.2.3 Pretests

Prior to attempting any learning in any concept area, a pretest to determine what he already knew about the area was given to each student. The pretest consisted of questions referenced to each core terminal objective in the concept area. Students were cautioned to attempt only those questions for which they were absolutely certain of the correct answer; therefore, items answered correctly would represent topics with which the student was thoroughly familiar. The extent of his knowledge, however, would be investigated, and depending upon those findings he would be given some options, such as exploring the area in depth or increasing knowledge in one part of the area, etc., to avoid needless repetition. This was one method of individualizing instruction.

### 3.2.4 Post Tests

When a student had completed all the core learning required in the concept area, he took a post test. Like the pretest, the post test included items referenced to each core terminal objective in that concept area, and as in the case of the unit tests, it was assumed that if the student correctly answered a criterion referenced question for a terminal objective, he had learned the objectives subsumed under it. Whenever a student answered correctly fewer than 90% of the items on the post test, he was given a prescription for remediation of his weaknesses and was required to take an alternate form (Z) of the post test. The Z form was usually the pretest for the concept area, but both the order of the questions and the order of the distractors had been rearranged. The scores on the post tests were used for grading purposes.

### 3.2.5 Enrichment Tests

In addition to the pre-, post and unit tests there were two enrichment tests in the course. These were very short tests including only criterion referenced items for each terminal objective in the enrichment segments, and students ensured credit for enrichment segments by passing 90% of the related test items. There were no make-up tests for enrichment, as it was envisioned that enrichment would frequently involve a special project designed cooperatively by the student and his instructor.

Figure 2 illustrates the testing sequence.

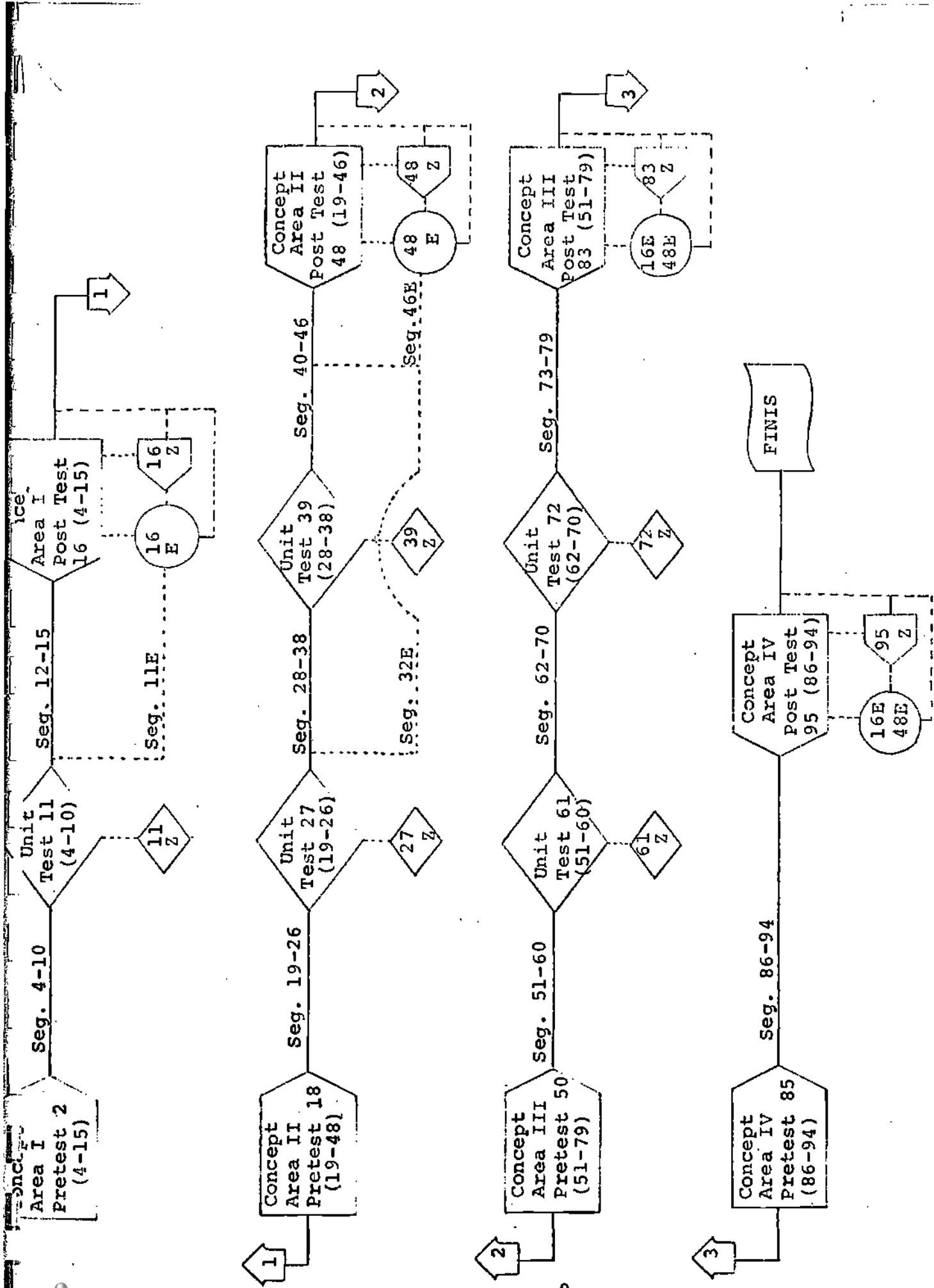

Fig. 2 - Testing Sequence for Multi-Media Economics Course

Did the analysis of the scores on the various tests indicate that the students had learned economics from studying the course materials? The answer to that is an unequivocal "yes." Student performance on the post tests, since these consisted of criterion referenced questions for each terminal objective in the concept area, was the main source of data used in answering this question. In view of the hierarchical nature of the course, the learning of one terminal objective represented not only the learning of the terminal objective itself but also of all the enabling objectives supporting it. The data in Table 2 show that the average number of objectives subsumed under a terminal objective did not vary widely from one concept area to another, whereas the approximate total number of specified objectives in each concept area varied widely. The total number of specified core objectives in the whole course was approximately 875, and in many cases students of necessity learned many more implied core objectives.

TABLE 2

Average Number of Enabling Objectives Supporting Each Terminal Objective in the Core Materials and Approximate Total Number of Objectives for Each Concept Area

<u>Concept Area</u>	<u>Ave. Number Enabling Obj.</u>	<u>Approx. Total Number Obj.</u>
I (Post Test 16)	8	135
II (Post Test 48)	7	296
III (Post Test 83)	7	344
IV (Post Test 95)	6	93

Analysis of all post test data for both groups considering the course as a whole reveals that approximately 88% of the entire body of students learned 75% or more of the core objectives. However, the breakdown of the data by concept area and group (see Table 3) gives a more complete picture of the performance.

TABLE 8

Correlation of Rank in Test Performance with  
Rank in SAT V, SAT Q and QPR for  
USNA Midshipmen

<u>Test</u>	<u>SAT V</u>	<u>SAT Q</u>	<u>QPR</u>
Unit 11	-.09	-.07	.33
Post Test 16	.12	.16	.07
Unit 27	.33	-.07	.30
Unit 39	.38	.45	.44
Post Test 48	.01	.00	.29
Unit 61	.24	-.09	.07
Unit 72	.25	-.34	.25
Post Test 83	.08	.24	.38
Post Test 95	-.52	-.05	.03

### 3.4 Learning Time

And now, the question of how long the students took to accomplish this learning should be considered. In this report learning time refers to the number of minutes a student used in learning one segment of self-instructional material. Each segment was designed to require approximately 50 minutes for the "C" student in the conventional system to complete; however, in light of the data, this amount of time seems generous. The difference between the in-house students and the Midshipmen in the mean length of time used in learning a segment was not very large, nor was the difference in the mean learning time for a segment in each concept area very great. Table 9 summarizes the mean number of minutes required by each group to learn one segment.

one semester. Had it been planned that a Midshipman could take the tests whenever he was ready to do so, undoubtedly some would have finished the course in less than one semester. In the usual 3 credit college course, 45 hours are spent in class, and students are expected to spend 90 hours in study outside of class for a total of 145 hours course time. The Multi-Media Course included 73 core segments, each designed to be learned in 50 minutes. Inasmuch as students used a mean time of less than 40 minutes to learn each of 49 segments, the real time required to learn the Multi-Media Economics Course, including all simulations, tests and enrichment, was considerably less than that theoretically expected in a 3-hour one semester course.

In a discussion of the practicality of the course materials some mention must be made of the Dymedia Response Board which was used by students for recording responses to all problems and tests and for obtaining immediate feedback as to their correctness. When interviewed about the course, the students were enthusiastic about the instant feedback and felt they learned because they were forced, when they made an error, to reread and to rethink a problem before they could go on. However, they found the board cumbersome and noisy, the latter being their major complaint. In view of the fact that the Dymedia device was effective in promoting learning, attention is being given to finding a substitute which would promote learning but lack the above-mentioned drawbacks.

### 3.7 Conclusion

The course materials can be viewed as "validated" because (a) students achieve the pre-established proportion of instructional objectives, (b) the students achieve these objectives within the time constraints that apply to the course, and (c) senior economists have judged the content and objectives to be "valid" economics.

## 4. Validation of Tests

The amount of learning which took place during the validation tryouts of the Multi-Media Economics Course was determined by analysis of student performance on tests. The analysis of the data would be meaningless, if the tests were not valid; therefore, an important task has been to establish the validity of the tests, i.e., to show the faithfulness with which the tests measure what they purport to measure. Validity also includes the reliability and practicality of the tests.

### 4.1 Content Validity of the Items

The content validity of the course materials was established by submitting them to the judgment of experts and comparing them with outstanding texts in the field. In establishing the content validity of test items again the judgment of subject matter experts was used.

When an economist-writer contracted to write course materials, he received not only the objectives for each segment but also three criterion referenced, multiple-choice test items which had been previously written for each objective in that segment. One of the tasks of the economist-writer was to check each item for content validity. Specifically, he answered these questions concerning each item:

- (1) Does the item test the objective?
- (2) Does the correct answer paraphrase or repeat the objective?
- (3) Are the distractors appropriate for the question and are they incorrect?
- (4) Is the item stated clearly and correctly?

If the content of the item needed revision, the economist-writer made the necessary changes; otherwise, the items remained as originally written.

Content validity was initially built into test items by making each one criterion-referenced. Each item paraphrased or was written in language equivalent to that of the objective it tested. At the same time, as they critically reviewed the objectives for the course, both the Naval Academy and Sterling Institute economists reviewed the criterion-referenced test items for the objectives and made appropriate changes. Moreover, prior to the validation tryouts at the Naval Academy, the in-house tryouts of the tests indicated that the items tested the objectives.

#### 4.2 Reliability

Inasmuch as a test cannot be considered valid unless it is reliable, several coefficients of reliability were obtained. The reliability of each test as a whole was established using the Kuder-Richardson Formula 20. Table 14 summarizes the coefficient of reliability obtained for each test and includes both the number of students who took the tests and the number of objectives tested. From the data it is apparent that Post Test 16 had practically no reliability, and that Unit Test 78 and Enrichment Tests 16E and 48E had little reliability. One factor present in all three which could account in part for the low reliability coefficient was the length of these tests. All had relatively few items. Some items in these tests were poorly written and as a result were ambiguous. During the summer 1969 all tests were revised in view of student error and the critiques of the Naval Academy instructors. Items were rewritten and the length of tests was changed. In some instances it was possible to substitute good items which had already been tried out by the Academy Midshipmen for poor ones which they had also tried. In light of these changes the reliability coefficients should increase.



TABLE 14

Coefficients of Reliability for Each Test  
in the Multi-Media Economics Course

<u>Test</u>		<u>N Students</u>	<u>N Objectives</u>	<u>r</u>
Pretest	2	38	15	.67
"	18	36	37	.91
"	50	40	38	.87
"	85	33	30	.86
Unit Test	11	39	18	.64
"	27	39	25	.79
"	39	37	38	.90
"	61	37	32	.72
"	72	53*	36	.46
Post Test	16	39	15	.15
"	48	38	37	.64
"	83	50*	52	.67
"	95	34	30	.81
Enrichment	16E	28	10	.46
"	48E	23	11	.48

\* In this N some students who inadvertently repeated the test are counted twice.

Since at least three test items were written for each objective, the question of the equivalency of these items arose. In other words, did students who answered the A item for objective X correctly, also answer the B item and the C item correctly? Some of the tests were constructed so that the B item for an objective occurred at the beginning of the test and the C item came toward the end of the same test. In others, the A and B or A and C items were used in the same way. A Pearson r was calculated to determine what relationship existed between the forms of the test items. Correlation coefficients of .72 and .78 for the B and C items, and .76 and .92 for the A and B and A and C items were obtained.

Because there were many objectives to be learned in Concept Area III, Post Test 83 retested terminal objectives previously tested in Unit Tests 61 and 72. A little more than two weeks elapsed between the original test and retest situations so that the possibility of any recall affecting the correlation was not great. A Pearson  $r$  of .76 between Unit Test 72 and Post Test 83 and of .61 between Unit Test 61 and Post Test 83 was obtained. The above-mentioned correlations for different forms of the test items indicate some degree of equivalency for the items.

#### 4.3 Item Difficulty and Discrimination Index

For the usual test, an item difficulty level<sup>5/</sup> of 40 to 60 is considered ideal, while an item with a level of 80 is considered very easy, and one with a level below 30 very difficult. The Multi-Media Economics Course was designed so that all students could successfully learn all core objectives, which meant that all students would pass every test item. Theoretically, then, the level of difficulty of each item should be 1.00. Item analysis of all the tests in the economics course indicated that 66% of the items had a difficulty level of 80 or above. Although the theoretically ideal level was not reached, two-thirds of the items approached that level. Table 15 presents the percentages of items in each test within the various levels of difficulty.

---

<sup>5/</sup> Item difficulty refers to the percentage of students who pass the item; item discrimination refers to the number of high-scoring students and the number of low-scoring students who pass a particular item.

TABLE 15

Percentages of Test Items Found at Each Level  
of Difficulty  
80+, 60-79, 40-59, below 39

<u>Test Number</u>	<u>% Items/Diff. Level 80+</u>	<u>% Items/Diff. Level 60-79</u>	<u>% Items/Diff. Level 40-59</u>	<u>% Items/Diff. Level Below 39</u>
11	72	28	0	0
16	60	7	13	20
27	88	12	0	0
39	89	5	5	1
48	78	16	3	3
61	56	31	13	0
72	53	36	11	0
83	60	35	4	1
95	40	37	17	6

Theoretically, there would be zero discrimination between the number of high scoring students and the number of low scoring students who pass an item, in the Multi-Media Economics Course, if its design were successful. Item analysis of all test data revealed that 54% of the items had a discrimination index of 20 or less. Over half of the items were approaching the ideal. Table 16 presents the percentage of items having a discrimination index of 20 or less for each test.

TABLE 16

Percentages of Items with Discrimination  
Index of 20 or Less

<u>Test Number</u>	<u>% Items Disc. Index 20 or less</u>
11	39
16	47
27	44
39	66
48	59
61	53
72	19
83	62
95	63

4.4 Practicality

That the tests be practical is an essential requisite of validity. The tests and test items of the economics course were practical in that they were easily and quickly scored, either manually or by machine. The self-tests and learning-embedded problems were readily corrected with immediate feedback from the Dymedia. No test required more than 50 minutes to be completed, and this included time for administrative procedures. It was possible to prescribe remedial work based on the individual's performance and designed to help him overcome his unique difficulties. With two equivalent forms available for each test, a make-up could be given and any gain in learning ascertained. Although all the tests to date have been objective, the instructor has retained the option to give essay type tests.

That the course has been tried out and students have successfully learned the course materials and passed the criterion referenced tests add to the practicality of both the tests and the course materials. Student reaction to the course as revealed in interviews with twenty-five randomly selected Midshipmen was enthusiastic and positive. They particularly liked being able to learn at their own speeds, and they appreciated knowing exactly what they were supposed to learn.

Only two students expressed unfavorable criticism. One of these, as he talked about the fact that he did not have enough time to study the course, realized that his problem was one of budgeting his time to include and not to exclude economics. The other student said there was too much reading required. All students were in agreement that learning in this course seemed more efficient and gave them a feeling of independence.

The instructors, too, were generally favorably impressed with the course, though it required them to adjust to a new role. They had more time for individual students, but they missed the role of lecturer.

Both students and instructors were most positive in declaring that the Multi-Media Economics Course effectively taught economics to the Midshipmen, a convincing argument for its validity.

## 5. Summary

The validation of the Multi-Media Economics Course, a self-paced, self-instructional course, took place at the United States Naval Academy and at the Educational Technology Center of Sterling Institute during the spring of 1969. Two sections of students regularly scheduled for economics at the Academy and a group of 10 students from universities in the Washington area participated in the tryouts. The data obtained were analyzed to determine whether the course materials did promote the expected changes in behavior at the predetermined levels and whether the tests and test items tested the instructional materials.

In order to establish the content validity of both the course materials and the test items, about twenty subject matter experts (economists) wrote the objectives and course materials, and also reviewed the test items for accuracy and suitability of content. In addition, the instructional material of the Multi-Media Economics Course was compared with the topics treated in two well-known economics texts. A high degree of similarity was found to exist in the topics discussed and in the points of view; however, the examples, presentation and depth of discussion in the Multi-Media Course were the original work of the economist-writers.

The self-instructional materials were effective in promoting the learning of economics at the expected level of performance, as evidenced by the following:

1. Approximately 80% of the students learned 80% or more of the core objectives. (The exception to this was the performance in Concept Area IV, explained in Table 3.)

2. Approximately 90 to 100% of the students learned 75% or more of the core objectives. (The exception to this was the performance in Concept Area IV. explained in Table 3.)
3. The mean difference in post test and pretest performance (learning gain) was statistically significant, at the .01 level of probability.
4. All students, regardless of rank in class and previous performances, were able to learn the core objectives.
5. The amount of learning time used to complete the course, which was generally recognized as being the equivalent of a two-semester course, was considerably less than the 145 hours allotted to a regular one semester 3-credit course. Most segments required a mean learning time of approximately 40 minutes.

In addition to establishing the content validity of the test items, it was necessary to check on their reliability. Analysis of test results revealed that with the exception of three of them, all tests were reliable and the three forms of the test items were found to have some degree of equivalence. The level of difficulty and the discrimination index of the majority of the test items were very satisfactory for this course. It should be noted that the economics course was designed so that all students could learn all core objectives. Consequently, the test items theoretically should have a difficulty level of 1.00 and a discrimination index of 0. All the tests were easily scored and administered and could be completed in 50 minutes, including the administration procedures. In addition, it was possible to prescribe remediation on an individual basis, depending on the student's test performance.

Most of the subjects found the course a welcome change in pace and were enthusiastic about learning economics by means of self-instructional materials. The instructors also found that this method brought about effective learning of economics.

Analysis of the data from the tryouts revealed that the Multi-Media Economics Course, including both instructional materials and tests, effectively produced the learning of economics at the expected levels of performance; therefore, this particular set of instructional materials in economics may be considered valid.

APPENDIX C

Number of Core Segments and Core Objectives

After the validation tryouts, Spring 1969, the Multi-Media Economic Analysis Course was revised. Materials were rewritten and in some instances reorganized to eliminate unnecessary repetition of objectives and to give a more logical sequence to them. Consequently, some segments were moved from one concept area to another, objectives were rewritten and sometimes a few were dropped. Table X summarizes by concept area the number of objectives and segments in the Fall 1969 Revision of the Multi-Media Economic Analysis Course.

TABLE X

Number of Core Segments and Core Objectives  
in Each Concept Area of the Multi-Media  
Economic Analysis Course, Fall 1969

<u>Concept Area</u>	<u>Segments</u>	<u>Objectives</u>
I	11	122
II	27	192
III	25	204
IV	12	77



APPENDIX D

Summaries of Student Critiques

Summary

STUDENT CRITIQUE SHEET

Student No. N=36

Control Test No. 11T

Date Fall 1969

1. Did you think the material was generally either too easy or too hard?

4 Yes, generally too easy

0 Yes, generally too hard

32 No, on the whole, neither too easy nor too hard

2. Were there any learning activities for which you felt that you did not have the necessary background?

35 No

1 Yes (If yes, please briefly describe them.)

3. Considering the experience you have had so far with this experimental instructional program, how would you compare it with the conventional lecture method of teaching courses?

35 I prefer the experimental instructional program.

0 I prefer the conventional lecture method.

1 I like the two approaches about the same.

4. Since your last Control Test, have you had any problem you feel is significant in one or more of the following areas?

Yes No

- 6  30 Having enough study time
- 1  35 Meeting with the instructor
- 1  35 Obtaining instructional materials
- 0  36 Obtaining equipment (tape recorders, projectors)
- 0  36 Getting help in understanding difficult material
- 4  32 Equipment operation
- 1  35 Reports on your progress
- 3  33 Arrangements for test-taking
- 1  Other (Please describe) *I need a better explanation of quantity demanded vs. demand.*

5. In one sentence, what do you now like best about the experimental instructional program?

- Work at own pace and convenience - 28*
- Concise format makes it easy to study and eliminates useless chatter - 6*
- Self-tests - 2*
- Immediate feedback - 1*
- Tapes - 1*
- Determining by contract goals and grade - 1*
- Time saved - 1*
- Objectives clearly stated - 1*
- No busy work - 1*
- More interesting - 1*

6. In one sentence, what do you now like least about the experimental instructional program?

- Nothing - 9*
- Difficult to arrange tests - 5*
- Filling out and punching cards - 4*
- Carrying Dymedia board - 4*
- It's too easy to procrastinate and let segments pile up - 3*
- Dymedia's do not always work - 3*
- Difficult to ask questions when help is needed - 2*
- Not enough taped segments - 1*
- Material too easy - 1*
- Material no repetitions - 1*
- No class discussions to relate to problems of today - 1*
- If person gets only a "C" for passing 9 core tests - 1*
- Instructions are redundant - 1*
- Forces you to think ahead and organize work - 1*
- Too many segments are tested in one test - 1*

*Summary*  
STUDENT CRITIQUE SHEET

16

Student No. N=33 Control Test No. 16P Date Fall 1969

1. Did you think the material was generally either too easy or too hard?

Yes, generally too easy

Yes, generally too hard

No, on the whole, neither too easy nor too hard

2. Were there any learning activities for which you felt that you did not have the necessary background?

No

Yes (If yes, please briefly describe them.)

3. Considering the experience you have had so far with this experimental instructional program, how would you compare it with the conventional lecture method of teaching courses?

I prefer the experimental instructional program.

I prefer the conventional lecture method.

I like the two approaches about the same.

4. Since your last Control Test, have you had any problem you feel is significant in one or more of the following areas?

*Two students checked NO answers to this question.*

Yes No

- 27* Having enough study time  
  *29* Meeting with the instructor  
  *29* Obtaining instructional materials  
  *30* Obtaining equipment (tape recorders, projectors)  
  *29* Getting help in understanding difficult material  
  *24* Equipment operation  
  *29* Reports on your progress  
  *29* Arrangements for test-taking  
  *0* Other (Please describe)

*Dymedia board broke down. Some pages were missing from one segment.*

5. In one sentence, what do you now like best about the experimental instructional program?

*Work at own pace and convenience - 22*

*Material is easy to understand because you learn specific points and then have examples or problems concerning them immediately - 3*

*Self-testing with feedback - 2*

*Concise explanations - faster and better - 2*

*No scheduled classes - 2*

*Everything - 1*

*Nothing - 1*

6. In one sentence, what do you now like least about the experimental instructional program?

*Nothing - 11*

*Dymedia - carrying machine, fillinout cards - 6*

*Schedule for tests - very limited - 3*

*Lack of opportunity for discussions - 2*

*Difficult to pace oneself - 2*

*Excessive repetition - 2*

*Impossible to find out exactly which question was missed - 2*

*Contract - 1*

*So many tests - 1*

*Explanation of material on tape not adequate - 1*

*Availability of material - 1*

*Questions are not in good format for learning - 1*

Summary

STUDENT CRITIQUE SHEET

Student No. N=35 Control Test No. 29T Date Fall 1969

1. Did you think the material was generally either too easy or too hard?

Yes, generally too easy

Yes, generally too hard

No, on the whole, neither too easy nor too hard

2. Were there any learning activities for which you felt that you did not have the necessary background?

No

Yes (If yes, please briefly describe them.)

*Personal Income, MNP, Investment*

3. Considering the experience you have had so far with this experimental instructional program, how would you compare it with the conventional lecture method of teaching courses?

I prefer the experimental instructional program.

I prefer the conventional lecture method.

I like the two approaches about the same.

4. Since your last Control Test, have you had any problem you feel is significant in one or more of the following areas?

Yes No

- 11  24 Having enough study time
- 2  33 Meeting with the instructor
- 1  34 Obtaining instructional materials
- 0  35 Obtaining equipment (tape recorders, projectors)
- 2  33 Getting help in understanding difficult material
- 1  34 Equipment operation
- 1  34 Reports on your progress
- 6  29 Arrangements for test-taking
- 0  0 Other (Please describe)

5. In one sentence, what do you now like best about the experimental instructional program?

- Can go at own speed -14*
- Allows personal initiative -6*
- Eliminates unnecessary reading, clear and precise presentation -4*
- Self-paced approach increases comprehension -3*
- You know what to learn and what not to learn -2*
- No classes -2*
- Time saved -1*
- Everything -1*

6. In one sentence, what do you now like least about the experimental instructional program?

- No complaints -7*
- Not enough test times scheduled -5*
- Dymedex - too heavy; run out of cards -4*
- Difficult to pace one self -3*
- Poor movies and hot room -3*
- Little opportunity to ask questions -2*
- Too much paper work -2*
- Organization of material - arrangement of segments -2*
- Concept Area II takes more time to learn than Concept Area I -1*
- Cannot see questions missed -1*
- Schedules for films are hard to obtain -1*
- Not all material is ready -1*
- Practice Exercises are too repetitive -1*
- Some concepts are not explained enough -1*
- Too repetitive -1*
- Too much reading -1*
- Must study 2-3 hrs. for a test and study must take place near test time -1*

SUMMARY  
STUDENT CRITIQUE SHEET

Student No. N=32 Control Test No. 39T Date Fall 1969

1. Did you think the material was generally either too easy or too hard?
- Yes, generally too easy
- Yes, generally too hard
- No, on the whole, neither too easy nor too hard
2. Were there any learning activities for which you felt that you did not have the necessary background?
- No
- Yes (If yes, please briefly describe them.)
3. Considering the experience you have had so far with this experimental instructional program, how would you compare it with the conventional lecture method of teaching courses?
- I prefer the experimental instructional program.
- I prefer the conventional lecture method.
- I like the two approaches about the same.



4. Since your last Control Test, have you had any problem you feel is significant in one or more of the following areas?

Yes No

- 14  18 Having enough study time  
 1  31 Meeting with the instructor  
 3  29 Obtaining instructional materials  
 0  32 Obtaining equipment (tape recorders, projectors)  
 1  31 Getting help in understanding difficult material  
 5  27 Equipment operation  
 2  30 Reports on your progress  
 7  25 Arrangements for test-taking  
 0  0 Other (Please describe)

5. In one sentence, what do you now like best about the experimental instructional program?

*Can work at own speed, self-paced - 21*  
*Working independently - 5*  
*Clear and precise presentation - 2*  
*Everything - 1*  
*No classes - 1*  
*Can learn more material quicker and better - 1*  
*Tests are consistent with material learned - 1*

6. In one sentence, what do you now like least about the experimental instructional program?

*No complaints - 14*  
*Heavy Dymedia Board; filling out cards - 4*  
*Too few test times scheduled - 2*  
*Takes too much time - 3*  
*Lack of classroom discussion - 2*  
*Too much repetition - 2*  
*Enrichment takes too long; no partial credit - 2*  
*Reading and reading when in difficulty does not increase understanding - 1*  
*Difficult to get help when needed - 1*  
*Difficult to budget time*

*Too many requirements for a high grade - 1*  
*Explanations of graphs - too wordy - 1*

*Summary*  
STUDENT CRITIQUE SHEET

Student No. N=35 Control Test No. 48P Date Fall 1969

1. Did you think the material was generally either too easy or too hard?
- 2 Yes, generally too easy
- 2 Yes, generally too hard
- 31 No, on the whole, neither too easy nor too hard
2. Were there any learning activities for which you felt that you did not have the necessary background?
- 35 No
- 0 Yes (If yes, please briefly describe them.)
3. Considering the experience you have had so far with this experimental instructional program, how would you compare it with the conventional lecture method of teaching courses?
- 34 I prefer the experimental instructional program.
- 0 I prefer the conventional lecture method.
- 1 I like the two approaches about the same.

4. Since your last Control Test, have you had any problem you feel is significant in one or more of the following areas?

Yes No

- 12  23 Having enough study time
- 2  33 Meeting with the instructor
- 6  29 Obtaining instructional materials
- 1  34 Obtaining equipment (tape recorders, projectors)
- 2  33 Getting help in understanding difficult material
- 4  31 Equipment operation
- 2  33 Reports on your progress
- 7  28 Arrangements for test-taking
- 2  0 Other (Please describe)

*Assignments too long  
Reg. 46 unclear*

5. In one sentence, what do you now like best about the experimental instructional program?

- Self-pacing independence; flexibility of program -21*
- Clear and precise presentation -6*
- No answers given -3*
- No classes -2*
- Everything -1*
- Continuous review of points from past segments which have bearing on new work makes learning easy -1*
- Audio segments for they cut reading time -1*

6. In one sentence, what do you now like least about the experimental instructional program?

- No complaints -12*
- There should be more test periods -2*
- Critique sheets after every test -2*
- Difficult to keep up because of <sup>lack of</sup> outside pressure -2*
- Repetition -2*
- Too much required for an A or B grade -2*
- Too much paper work - time keeping -2*
- Difficult to get help -1*
- Great amounts of material covered by tests -1*
- Not having a course similar to this next semester -1*
- Repts on progress -1*
- Too time consuming -1*
- Audio because it loses the effect of teaching oneself -1*
- Lack of classroom discussion -1*
- Style format getting dull -1*
- No Relevancy -1*

Summary

STUDENT CRITIQUE SHEET

Student No. N=33

Control Test No. 61T

Date Fall 1969

1. Did you think the material was generally either too easy or too hard?

Yes, generally too easy

Yes, generally too hard

No, on the whole, neither too easy nor too hard

2. Were there any learning activities for which you felt that you did not have the necessary background?

No

Yes (If yes, please briefly describe them.)

*Explanation for elasticity not clear*

3. Considering the experience you have had so far with this experimental instructional program, how would you compare it with the conventional lecture method of teaching courses?

I prefer the experimental instructional program.

I prefer the conventional lecture method.

I like the two approaches about the same.

4. Since your last Control Test, have you had any problem you feel is significant in one or more of the following areas?

Yes No

- 7     26    Having enough study time
- 1     32    Meeting with the instructor
- 1     32    Obtaining instructional materials
- 0     33    Obtaining equipment (tape recorders, projectors)
- 1     32    Getting help in understanding difficult material
- 2     31    Equipment operation
- 1     32    Reports on your progress
- 2     31    Arrangements for test-taking
- 4     0    Other (Please describe)

*Materials incorrect  
 Misleading questions on test  
 Proof reading bad*

5. In one sentence, what do you now like best about the experimental instructional program?

- Self-paced; freedom to work at own times; having responsibility for learning 23*
- Concise, clear, easy to follow -3*
- Quick way to learn -2*
- Everything -1*
- Self-tests -1*
- No classes -1*
- Not having to listen to a lecture -1*
- Can now discuss economics with parents & friends; can understand newspaper stories re economics -6*

6. In one sentence, what do you now like least about the experimental instructional program?

- No complaints -8*
- Filling out cards -4*
- Tendency to procrastinate and neglect course -3*
- Lack of classroom discussion -2*
- Format - dull, slow -2*
- Computer simulation - spend too much time for amount of learning -2*
- Can't take enrichment tests over -1*
- Course seems long -1*
- Repetition -1*
- Not enough times scheduled for taking tests -1*
- Can't learn from questions on tests -1*
- (4 Did not answer this part)*
- Can't get help when needed -1*
- Length of problems in segments -1*
- Some explanations not clear -1*
- Tests cover too much -1*

*Summary*  
STUDENT CRITIQUE SHEET

Student No. N-29

Control Test No. 72 T Date Fall 1969

1. Did you think the material was generally either too easy or too hard?
- Yes, generally too easy
- Yes, generally too hard
- No, on the whole, neither too easy nor too hard
2. Were there any learning activities for which you felt that you did not have the necessary background?
- No
- Yes (If yes, please briefly describe them.)
3. Considering the experience you have had so far with this experimental instructional program, how would you compare it with the conventional lecture method of teaching courses?
- I prefer the experimental instructional program.
- I prefer the conventional lecture method.
- I like the two approaches about the same.

4. Since your last Control Test, have you had any problem you feel is significant in one or more of the following areas?

Yes No

- 4  25 Having enough study time
- 1  28 Meeting with the instructor
- 1  28 Obtaining instructional materials
- 0  29 Obtaining equipment (tape recorders, projectors)
- 2  27 Getting help in understanding difficult material
- 1  28 Equipment operation
- 0  29 Reports on your progress
- 0  29 Arrangements for test-taking
- 0  0 Other (Please describe)

5. In one sentence, what do you now like best about the experimental instructional program?

- Self-paced, freedom, independence -17
- No class -3
- Fast and efficient, saves time and learn more -2
- The way the lessons make you draw conclusions -1
- No final exams - exams as you go along -1
- Self-tests -1
- Concise and clear materials -1
- Learning more about my country's economy -1

*2 people did not write an answer*

6. In one sentence, what do you now like least about the experimental instructional program?

- No complaints - 8
- Long segments - 3
- Repetition - 2
- There should be a course like this 2nd semester - 2
- Inability to get help when needed -1
- No daily requirements leads to neglect of course -1
- Lack of classroom discussion -1
- Way graphs are handled -1
- All segments alike in format -1
- Must do work in one sitting rather than bit by bit -1

*4 did not write an answer to this question*

*Nine examples with bad concepts -1*

Summary

STUDENT CRITIQUE SHEET

Student No. N=29

Control Test No. 80P

Date Fall 1969

1. Did you think the material was generally either too easy or too hard?

0 Yes, generally too easy

2 Yes, generally too hard

27 No, on the whole, neither too easy nor too hard

2. Were there any learning activities for which you felt that you did not have the necessary background?

29 No

0 Yes (If yes, please briefly describe them.)

3. Considering the experience you have had so far with this experimental instructional program, how would you compare it with the conventional lecture method of teaching courses?

24 I prefer the experimental instructional program.

0 I prefer the conventional lecture method.

5 I like the two approaches about the same.



4. Since your last Control Test, have you had any problem you feel is significant in one or more of the following areas?

Yes No

*1 person did NOT answer question 4.*

- 0  22 Having enough study time
- 0  28 Meeting with the instructor
- 0  28 Obtaining instructional materials
- 0  28 Obtaining equipment (tape recorders, projectors)
- 1  27 Getting help in understanding difficult material
- 2  26 Equipment operation
- 2  26 Reports on your progress
- 2  26 Arrangements for test-taking
- 1  0 Other (Please describe)

*Should be able to have test questions.*

5. In one sentence, what do you now like best about the experimental instructional program?

- Self-pacing; independence - 18*
- Learn more per unit of time - 5*
- Clear, concise, easy to understand - 2*
- Self-testing - 2*
- Highly standardized - all students get same materials - 1*
- No grades - 1*
- Everything - 1*
- Segments cover full field of economics - 1*

6. In one sentence, what do you now like least about the experimental instructional program?

- No complaints - 6*
- Some segments - ambiguous - 2*
- Punching cards - 2*
- Lack of class discussion - 1*
- Too abstract - 1*
- Too many ideas in Concept Area III - 2*
- No daily requirements lead to neglect - 1*
- Too few test times - 1*
- All or nothing for enrichment tests - 1*
- Cannot learn from mistakes - 1*
- References to previous statements, not class - 1*

*6 students wrote nothing for this question.*

- Would like similar course next semester but non-scheduled - 1*
- Can't spread out work without loss of comprehension - 2*
- Filling out critique sheet - 1*



4. Since your last Control Test, have you had any problem you feel is significant in one or more of the following areas?

Yes No

- 5  17 Having enough study time
- 1  21 Meeting with the instructor
- 0  22 Obtaining instructional materials
- 0  22 Obtaining equipment (tape recorders, projectors)
- 0  22 Getting help in understanding difficult material
- 0  22 Equipment operation
- 2  20 Reports on your progress
- 0  22 Arrangements for test-taking
- 2  22 Other (Please describe)

5. In one sentence, what do you now like best about the experimental instructional program?

- Self-paced, plan own course, independent study - 15*
- No classes - 3*
- Teaches important aspects, clearly and concisely - 3*
- Self-testing - 1*
- Possibility of teaching large nos. of students with - 1*
- Minimum # of instructors*

6. In one sentence, what do you now like least about the experimental instructional program?

- No complaints - 8*
- Some materials - confusing and too difficult - 4*
- Lack of class discussions - 2*
- Not able to contact instructor - 2*
- Films not beneficial - 1*
- Need self-discipline to keep going - 1*
- Dy media Board - 1*
- Takes more time to study than regular program - 1*
- Computer simulations - 1*
- Filling out critique sheets - 1*

END OF COURSE CRITIQUE

N=39

Films

1. Do you think the films were effective as a supplement to make the course more relevant and interesting?

<u>Yes</u>	<u>No</u>
27	12

2. Do you think the films helped you to learn and to retain economic theory and/or policy that you would not have learned or retained had you not attended the films?

<u>Yes</u>	<u>No</u>	<u>Some</u>
15	20	4

3. Did the material presented in the films dovetail well with the material presented in the printed or audio self-instructional segments?

<u>Yes</u>	<u>No</u>	<u>Sometimes</u>	<u>No Answer</u>
28	6	3	2

4. How often did films conflict with or contradict materials in the regular segments?

<u>Never</u>	<u>Seldom</u>	<u>Don't Know</u>	<u>No Answer</u>
12	15	1	5

5. Do you think the films helped you do better on the unit and post tests?

<u>Yes</u>	<u>No</u>	<u>Sometimes</u>
12	20	7

Films (Continued)

6. What did you like best about the films?
- (1) Change of pace; variety..... 5
  - (2) Aid in clarifying material; review; augmented printed material; reinforcement of printed segments..... 12
  - (3) Realistic examples; relevant material..... 7
  - (4) Good presentation; logical; clear, concise..... 7
  - (5) More interesting than reading..... 2
  - (6) Extra points earned..... 9
  - (7) Nothing..... 1
  - (8) No answer given..... 4
7. What did you like least about the films?
- (1) Room where given needed better circulation. 2
  - (2) Boring; out of date; waste of time..... 23
  - (3) Irrelevant to segment or lessons I was studying at that time..... 7
  - (4) Too long; poorly constructed; poor narrator..... 9
  - (5) Film test - ambiguous questions; too little time for it..... 2
  - (6) Instructed less well than printed segments. 3
  - (7) Schedule of films inconvenient..... 5
  - (8) Not enough films..... 1
  - (9) Nothing..... 1
  - (10) No answer given..... 2

## END OF COURSE CRITIQUE

### Course as a Whole

8. Do you think that the knowledge you will take away from this course will be more or less valuable than the knowledge you would take away from an economic analysis course taught by the traditional lecture method, assuming an average instructor for the latter?

<u>More Valuable</u>	<u>Less Valuable</u>	<u>Same</u>	<u>No Answer Given</u>
30	2	3	4

9. How do you think this course would compare in learning efficiency (that is, in the amount of information or concepts learned per unit of time spent) with the traditional lecture course in economic analysis?

This course is:

<u>Much More Efficient</u>	<u>Somewhat More Efficient</u>	<u>About as Efficient</u>	<u>Less Efficient</u>
23	16		

10. How much time throughout the whole course would you estimate that you spent referring to or studying one of the standard texts?

<u>None</u>	<u>Less than 1 hr.</u>	<u>4-5 hrs.</u>	<u>No Answer Given</u>
27	8	2	2

11. How much time throughout the course did you spend talking to your professor about the course content to gain a better understanding of the content?

<u>None</u>	<u>1/2 hr. or less</u>	<u>1½ to 3 hrs.</u>	<u>No Answer Given</u>
22	10	7	0

Course as a Whole (continued)

12. How much time throughout the course did you spend talking to your professor about procedural problems or difficulties with getting the computer simulations to run right?

<u>None</u>	<u>Very Little (less than ½ hour)</u>	<u>2 - 3 hrs.</u>	<u>No Answer Given</u>
14	21	2	2

13. How do you think the material or structure and functioning of this course might be improved?

- (1) Occasional non-mandatory seminars, discussions, or lecture to make course relevant to present-day economic policies and problems..... 22 students, 27 times
- (2) More times scheduled for test taking..... 6
- (3) Eliminate, deemphasize or improve computer simulations..... 5
- (4) Update films..... 3
- (5) More audios..... 2
- (6) Review sessions at the end of a concept area..... 2
- (7) Vary form of printed segments..... 2
- (8) More questions on enrichment..... 2

Audio Critique

1. For which segments did you use audio materials alone, without referring to printed segments?

<u>8-10</u>	<u>8 only</u>	<u>22-26</u>	<u>43-46</u>	<u>43,44 only</u>
7	1	3	4	1 1

2. For which segments did you use both the audio material and the printed packages?

<u>None</u>	<u>9</u>	<u>10</u>	<u>22</u>	<u>23</u>	<u>24</u>	<u>25</u>	<u>26</u>	<u>44</u>	<u>45</u>	<u>46</u>
14	1	1	1	1	1	1	1	1	1	1

3. What things did you like about the audio materials?

(1) Saves time.....	7
(2) A change.....	4
(3) Easy to concentrate.....	3
(4) Easy to understand.....	6
(5) Nothing.....	1

4. What things did you dislike about the audio materials?

(1) Nothing.....	8
(2) Boring.....	2
(3) Could not concentrate.....	1
(4) Takes longer than reading.....	3
(5) Explanations not as good; seems to dwell on details.....	3
(6) Could not go back over it easily.....	1



Audio Critique (continued)

5. Did you find that the audio materials made learning easier? If yes, why?

	<u>Yes</u>	<u>No</u>
	12	6
(1) Easier to concentrate.....		6
(2) Material followed a more logical sequence.	1	
(3) Easier to listen than to read.....	1	
(4) Relaxing; novelty.....	2	
(5) Good supplement to printed segments.....	1	

6. Did you find that audio materials made learning harder? If yes, why?

	<u>Yes</u>	<u>No</u>
	2	14
(1) Did not learn as much.....		1
(2) Boring.....		2
(3) Could not go back over materials easily..		1

7. Do you think that the audio options are valuable as a means of providing a stimulating variety of learning modes for the student to choose from?

<u>Yes</u>	<u>No</u>
14	3

8. Do you think there should be more audio options in the course?

<u>Yes</u>	<u>No</u>
13	4