

DOCUMENT RESUME

ED 040 875

SE 008 985

AUTHOR Oguntunde, P. A.; And Others
TITLE Modern Mathematics for the Junior High School,
Geometry 1, Part 1.
INSTITUTION Comprehensive High School, Aiyetoro (Nigeria).
PUB DATE Aug 66
NOTE 231p.

EDRS PRICE EDRS Price MF-\$1.00 HC-\$11.65
DESCRIPTORS *Curriculum Development, Geometric Concepts,
*Geometry, *Instructional Materials, *Secondary
School Mathematics, *Textbooks
IDENTIFIERS Nigeria

ABSTRACT

This textbook is a part of a four-volume experimental series dealing with basic concepts and ideas in modern mathematics. It was the wish of the authors to present material which the students would understand, rather than memorize. Professional assistance was provided by Harvard University. The material is divided into four chapters: (1) sets of points, (2) plane figures, (3) congruent figures, and (4) basic constructions. Cumulative tests are provided at the end of each chapter. (RS)

F-AID
SE

THIS DOCUMENT HAS BEEN REPRODUCED EXACTLY AS RECEIVED FROM THE
PERSON OR ORGANIZATION ORIGINATING IT. POINTS OF VIEW OR OPINIONS
STATED DO NOT NECESSARILY REPRESENT OFFICIAL OFFICE OF EDUCATION
POSITION OR POLICY.

MODERN

MATHEMATICS

For the

Junior High School

GEOMETRY 1

Part 1

**MATHEMATICS DEPARTMENT
COMPREHENSIVE HIGH SCHOOL
AIYETORO, WESTERN NIGERIA.**

ED0 40875

SE 008 985

COPYRIGHT 1966 by the PRESIDENT AND FELLOWS OF HARVARD COLLEGE

Reproduction in whole or in part permitted for any purpose of the Ministry of Education, Government of Nigeria or of the Government of the United States.

**"PERMISSION TO REPRODUCE THIS
COPYRIGHTED MATERIAL HAS BEEN GRANTED
BY the President and Fellows
of Harvard College**

**TO ERIC AND ORGANIZATIONS OPERATING
UNDER AGREEMENTS WITH THE U.S. OFFICE OF
EDUCATION. FURTHER REPRODUCTION OUTSIDE
THE ERIC SYSTEM REQUIRES PERMISSION OF
THE COPYRIGHT OWNER."**

Lagos, Nigeria 1966

PREFACE

This series of textbooks in modern mathematics for the Junior Secondary School is printed in four volumes: Geometry 1, Part 1 and Part 2, which appears here, and Algebra 1, Part 1 and Part 2, which was printed in January 1966.

The primary purpose of this series is to introduce Secondary School Form I and Form II students to some basic concepts and ideas in modern mathematics. These books assume a knowledge of mathematics through the Primary 6 Programme in Nigeria. The material contained in these volumes takes the students through some mathematics with which they are already familiar, but approaches it from a different and modern point of view. This material also introduces the students to ideas with which they are not familiar. The combination of these two approaches will help lay a firm foundation for further work in modern mathematics.

This series of books can be utilized in the following ways:

(1) as a transition course from a traditional Primary School background to a Secondary Grammar School Programme in modern mathematics, such as that represented by the Entebbe Mathematics Series, or the Southampton Mathematics Project.

(2) as a complete two-year course Programme in modern mathematics for those students in a Junior Secondary School.

(3) in conjunction with other material, as a three-year course Programme in modern mathematics for those students in a Grammar School who do not plan to take mathematics up to the School Certificate Examination level.

This series of books was written by members of the Mathematics Department of the Comprehensive High School, Aiyetoro, Western Provinces, during the school year 1965 and the first term of 1966. The material was initially written,

taught in the classroom by five different teachers to seven Sections, and then rewritten in the light of that classroom experience. These books are still experimental texts, and any comments, suggestions, and criticism would be greatly appreciated.

The authors feel that the material is presented in such a way that the student will understand the basic concepts and structure of mathematics, rather than commit them to memory. Also, there are many and varied exercises to help reinforce the student's understanding of these basic ideas.

The authors wish to thank the Ministry of Education of the Western Provinces and the Chief Inspector, Mr. H.M.B. Somade, for the freedom to develop this material; they wish to thank Mr. J.B.O. Ojo, Principal of the Comprehensive High School, for his faith in their work; they wish to thank Harvard University for its professional assistance; they wish to thank Professor Merrill E. Shanks of Purdue University for his helpful criticism of the Geometry 1 material; they wish to thank the Communications Media Services and Mr. Richard Wolford of the United States Agency for International Development, Lagos, for printing these books; and they wish to thank their wives for much patience and understanding throughout the school year.

Mathematics Department

P.A. Oguntunde, Chairman

Mrs. A. Odusanwo Daniels

Richard A. Little

J.B.O. Ojo

Joseph P. Pavlovich

Comprehensive High School
Aiyetoro, Western Provinces
August 1966

TO THE TEACHER

This series of textbooks in modern mathematics was written for a broad spectrum of students' ability: for the very good student on the one hand, to the rather poor student on the other. This series can be taught to a wide ability spectrum by properly pacing the material according to the needs of the class. The following table may serve as a rough guide to help you estimate your time:

<u>Type of Student</u>	<u>Length of Time</u>	
	<u>Algebra 1</u>	<u>Geometry 1</u>
Very Good	2 $\frac{1}{2}$ Terms	1 $\frac{1}{2}$ Terms
Average	3 Terms	2 Terms
Poor	3 $\frac{1}{2}$ Terms	2 $\frac{1}{2}$ Terms

The exercises are the key to proper pacing. Included are more than enough exercises for all but the very slow student. In your assignments for homework, give enough exercises from each section of the text to occupy the students for 30-45 minutes per day. The fast student may require only a judicious selection of exercises from each section in order to master the idea involved, whereas a slow student may have to spend two or three assignments on one section of exercises for full comprehension.

This series of books was designed to give you the teacher a wide choice for adaptation to your own purposes and needs. You may wish to use the Algebra 1, Part 1 and Part 2 texts during most of Form I, then teach from Geometry 1, Part 1 and Part 2 during the Form II year. Or, you may wish to use the texts in the order in which they are presented at the Comprehensive High School: Algebra 1, Part 1, followed by Geometry 1, Part 1 during most of the Form I year, and then Algebra 1,

Part 2 and Geometry 1, Part 2 at the end of Form I and during the beginning of the Form II year.'

The present plan at the Comprehensive High School is to use the new, revised version of Entebbe Mathematics Series, C-One to C-Four, during the remainder of Form II, and in Forms III, IV and V for those students in the Academic Programme. We feel that our series of books, in conjunction with the Entebbe series, offers a modern and complete curriculum of Secondary School mathematics. This curriculum will prepare the student for the new School Certificate Examination in mathematics, to be offered by the West African Examinations Council for the first time in 1967.

Included at the end of each chapter of Algebra 1 and Geometry 1 are two Revision Tests and one Cumulative Revision Test. These tests are included not only for revision purposes, but perhaps more important, to give you the teacher a good idea of the type of question which you may ask on a test of your own. There are true-false questions, short answer questions, sentence completion questions, and matching questions, in addition to the more traditional type of essay questions, for you to change, modify and adapt to your own particular needs.

We all agree that testing is an important part of the learning experience. The included tests will not only help you to devise different types of your own tests, but they will also help you to test more frequently. Thus testing will become not only a method of measuring your students' achievement, but it will also become an integral part of their learning experience.

.....

TABLE OF CONTENTS

PART I

Chapter 1 Sets of Points

1-1	Introduction	1
1-2	What is a Point ?	1
1-3	What is a Line ?	3
1-4	What is a Line Segment ?	9
1-5	Measure of Line Segments	14
1-6	What is a Ray ?	21
1-7	What is an Angle ?	26
1-8	Measure of Angles	31
1-9	Types of Angles	38
1-10	Perpendicular and Parallel Lines	49
	<u>Revision Test # 1</u>	56
	<u>Revision Test # 2</u>	59

Chapter 2 Plane Figures

2-1	What is a Plane ?	63
2-2	More About Angles	64
2-3	Closed Plane Figures	71
2-4	Polygons	74
2-5	Triangles	79
2-6	Line Segments and Triangles	87
2-7	More About Parallel Lines	94
2-8	Quadrilaterals	99
2-9	Special Parallelograms	105
2-10	Polygons of More Than Four Sides	113
2-11	Sum of Measures of the Interior Angles of a Polygon	116

2-12	Sum of Measures of the Exterior Angles of a Polygon	120
2-13	Circles	122
	<u>Revision Test # 3</u>	125
	<u>Revision Test # 4</u>	127
	<u>Cumulative Revision Test # 1</u>	129

Chapter 3 Congruent Figures

3-1	Introduction	133
3-2	Congruent Segments and Congruent Angles ...	134
3-3	Congruent Figures	136
3-4	Congruent Triangles	139
3-5	Congruence of Triangles: Two Sides and the Included Angle (SAS)	143
3-6	Congruence of Triangles: Three Sides (SSS).	148
3-7	Congruence of Triangles: Two Angles and One Side (ASA or AAS)	153
3-8	Congruence of Right Triangles: Hypotenuse and a Side (RHS)	160
3-9	Summary of Congruent Triangles	164
3-10	Corresponding Parts of Congruent Triangles .	169
	<u>Revision Test # 5</u>	174
	<u>Revision Test # 6</u>	176
	<u>Cumulative Revision Test # 2</u>	179

Chapter 4 Basic Constructions

4-1	Introduction	183
4-2	Set Squares	184
4-3	Straightedge and Compass	188
4-4	To Draw the Perpendicular to a Line Through a Point On the Line	190

4-5	To Draw the Perpendicular to a Line Through a Point Not On the Line	192
4-6	To Draw the Perpendicular Bisector of a Line Segment	197
4-7	To Copy An Angle	201
4-8	To Bisect An Angle	204
4-9	To Draw a Line Parallel to a Given Line Through a Given Point Not On that Line	208
4-10	Construction of Triangles	211
	<u>Revision Test # 7</u>	214
	<u>Cumulative Revision Test # 3</u>	216
	<u>Cumulative Revision Test # 4</u>	219

Chapter 1

Sets of Points

1-1 Introduction

Thus far in your study of mathematics, you have been working with numbers. You have studied sets of numbers, such as the set of natural numbers, and the set of whole numbers. You have studied some basic properties of these sets of numbers. You have also learned about a variable. You used the properties of numbers to help you find truth sets of sentences which contained a variable. All of these ideas which you have studied thus far are in that branch of mathematics called algebra.

We shall now begin a study of another branch of mathematics called geometry.

We said that algebra is primarily concerned with numbers, and sets of numbers. Geometry is primarily concerned with points, and sets of points.

1-2 What is a Point ?

When you started your work in algebra, you first learned about a number. You learned that the idea of a number is one of the basic concepts of algebra. We then developed other ideas from the concept of number.

A basic concept in geometry is that of a point. We shall use the concept of point to build other ideas in geometry.

Here is a picture of a point A:

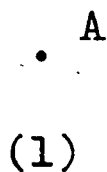

In figure (1), we represented the point A by a dot on this paper. However, the dot in figure (1) is not the

2. Make a picture of five different points, and label them D, E, F, G and H.
- Why are the points D, E, F, G and H different from each other ?
 - Why are the points D, E, F, G and H different from the points A, B and C in Exercise 1 above ?

1-3 What is a Line ?

Here is a picture of a line AB:

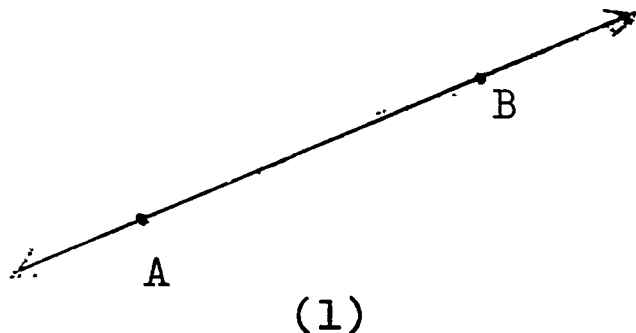

Notice that figure (1) is a straight line through two points A and B. Also notice the arrowheads on the line AB in figure (1). These arrowheads tell us that the line AB goes on infinitely in both directions. Thus, a line has no endpoint.

When we speak of a line which contains points A and B, we say "line AB". Let us agree to write " \overleftrightarrow{AB} " for "line AB". Hence, " \overleftrightarrow{AB} " means "the set of all points on the line which contains points A and B".

Using set notation, we may write this in the following way:

$$\overleftrightarrow{AB} = \left\{ \begin{array}{l} \text{All points on the line which} \\ \text{contains points A and B} \end{array} \right\}$$

Notice that the symbol " $\overleftrightarrow{\quad}$ " is an arrow in both directions. This symbol reminds us that the line AB goes on

infinitely in both directions. Also notice that we may write either " line AB " or " \overleftrightarrow{AB} ". We shall not write " line \overleftrightarrow{AB} ". Also, we shall not write simply " AB " .

Since both points A and B are on line AB, we could also speak of " line BA " . What can you say about \overleftrightarrow{AB} and \overleftrightarrow{BA} ?

We know that a line is an infinite set of points. We also know that two sets are equal when they contain the same elements. Now:

$$\overleftrightarrow{BA} = \left\{ \begin{array}{l} \text{all points on the line which} \\ \text{contains points B and A} \end{array} \right\} .$$

Since the two sets \overleftrightarrow{AB} and \overleftrightarrow{BA} contain the same points, we may write:

$$\overleftrightarrow{AB} = \overleftrightarrow{BA} .$$

If we wish to draw two lines in the same picture, we must use different letters because the lines contain different points.

For example, here is a picture of two lines:

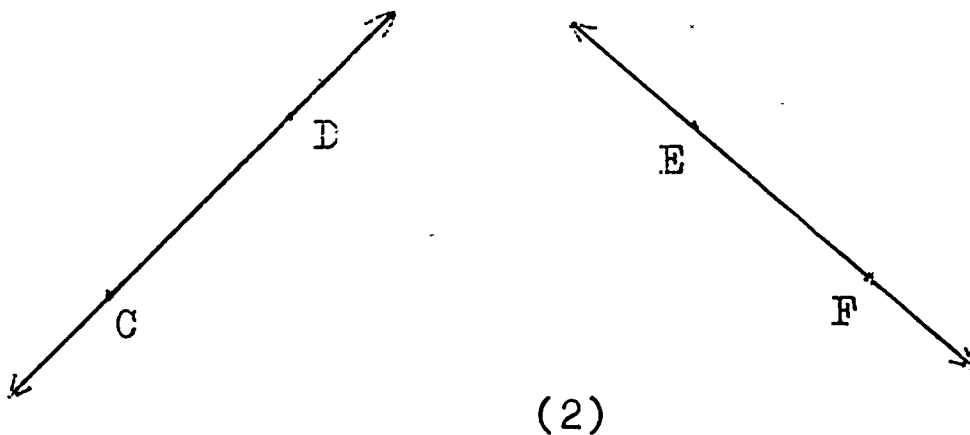

We can easily see that in figure (2), \overleftrightarrow{CD} is different from \overleftrightarrow{EF} . We may write:

$$\overleftrightarrow{CD} \neq \overleftrightarrow{EF} .$$

We know that \overleftrightarrow{CD} and \overleftrightarrow{EF} extend infinitely in both directions. Let us extend the two lines in figure (2) so that

they cross or intersect each other at a point P, as in this picture:

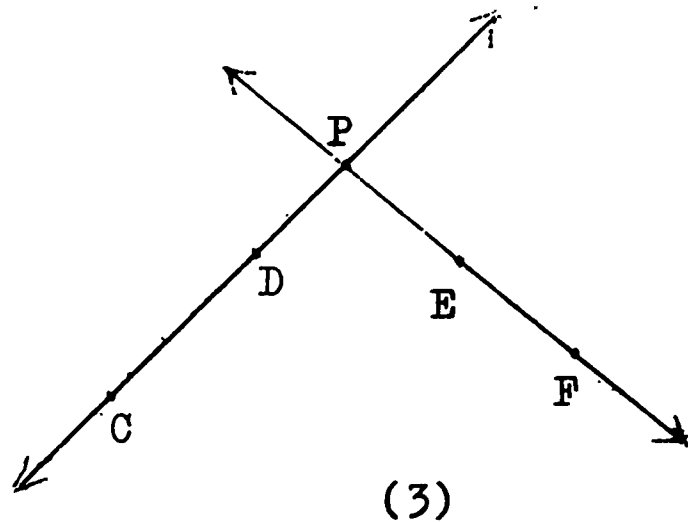

The point P is a member of the set of points \overleftrightarrow{CD} .
The point P is also a member of the set of points \overleftrightarrow{EF} .

Recall that for any two sets Q and R, Q intersection R is the set of all elements in both Q and R. We write " $Q \cap R$ " for "Q intersection R".

Now \overleftrightarrow{CD} and \overleftrightarrow{EF} are sets of points. In figure (3), the point P is the point of intersection of \overleftrightarrow{CD} and \overleftrightarrow{EF} . Hence we may write:

$$\overleftrightarrow{CD} \cap \overleftrightarrow{EF} = \{P\}.$$

Notice that we wrote $\{P\}$, using set brackets. Since \overleftrightarrow{CD} is a set, and \overleftrightarrow{EF} is a set, then the intersection of two sets is a set.

Now look at this picture of \overleftrightarrow{GH} and \overleftrightarrow{HJ} :

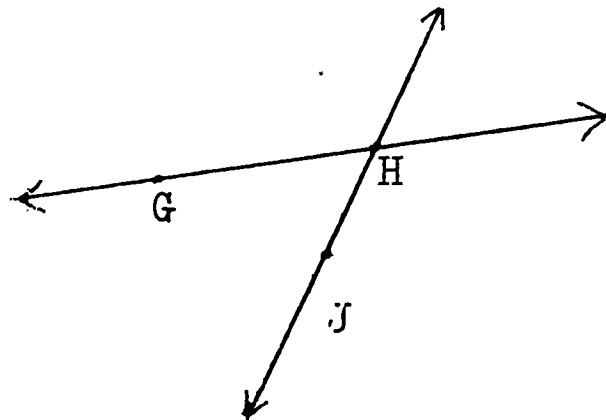

Because we used the same letter H in both \overleftrightarrow{GH} and \overleftrightarrow{HJ} ,

the point H must be on both lines. H is the point of intersection of \overleftrightarrow{GH} and \overleftrightarrow{HJ} . We may write:

$$\overleftrightarrow{GH} \cap \overleftrightarrow{HJ} = \{H\}$$

Let us now study a line in which we have three points on the line. The picture may look like this:

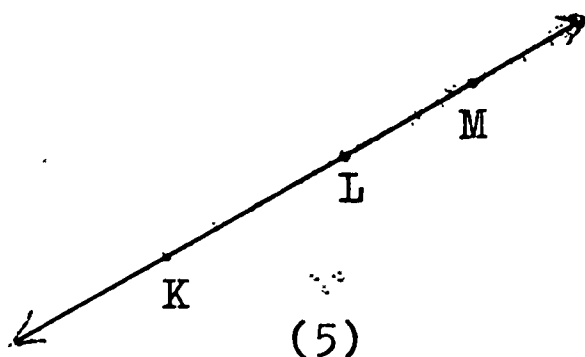

Notice that in figure (5), the point M is on \overleftrightarrow{KL} opposite from K . However, we could have taken the point M between K and L on \overleftrightarrow{KL} . We could also have taken the point M on \overleftrightarrow{KL} opposite from L .

However, in the representation of \overleftrightarrow{KL} in figure (5), \overleftrightarrow{KL} , \overleftrightarrow{LM} , \overleftrightarrow{MK} , and \overleftrightarrow{ML} are all names for the same line.

Since \overleftrightarrow{KL} , \overleftrightarrow{LM} , \overleftrightarrow{MK} , and \overleftrightarrow{ML} are the same set of points in the representation of \overleftrightarrow{KL} in figure (5), we may write:

$$\overleftrightarrow{KL} = \overleftrightarrow{KM} = \overleftrightarrow{LM} = \overleftrightarrow{MK} = \overleftrightarrow{ML} .$$

(1) A picture of a line AB looks like this:

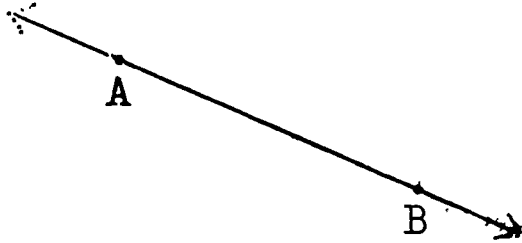

(2) The symbol for "line AB" is " \overleftrightarrow{AB} ".

(3) \overleftrightarrow{AB} extends infinitely in both directions.

(4) $\overleftrightarrow{AB} = \left\{ \begin{array}{l} \text{All points on the line which} \\ \text{contains points A and B} \end{array} \right\}$

(5) If C is a third point on \overleftrightarrow{AB} , then \overleftrightarrow{AB} , \overleftrightarrow{AC} , \overleftrightarrow{BC} , \overleftrightarrow{BA} , \overleftrightarrow{CA} , and \overleftrightarrow{CB} all name the same line.

Exercises 1-3

1. a. Draw one point A in your notebook.
 b. Draw a line which contains point A.
 c. Draw a second line which contains point A.
 d. Draw a third line which contains point A.
 e. How many lines can you draw which contain point A?
2. a. Draw any two points E and F in your notebook.
 b. Draw the line which contains both E and F.
 c. Can you draw a second line which also contains E and F?
 d. What is the minimum number of points which you need to determine exactly one line?
3. a. Draw any three points G, H and I in your notebook. Make sure that the three points are not on one straight line.
 b. Draw \overleftrightarrow{GH} , \overleftrightarrow{HI} , and \overleftrightarrow{GI} .

- c. Is $\overleftrightarrow{GH} = \overleftrightarrow{HG}$? Do \overleftrightarrow{HG} and \overleftrightarrow{GH} contain the same points?
Is \overleftrightarrow{GI} another name for \overleftrightarrow{IG} ?
- d. $\overleftrightarrow{GH} \cap \overleftrightarrow{HI} = ?$; $\overleftrightarrow{HI} \cap \overleftrightarrow{GI} = ?$; $\overleftrightarrow{GH} \cap \overleftrightarrow{GI} = ?$
- e. If only two lines intersect at a point, what is the maximum number of points of intersection of three lines?
- f. Is it possible to have three lines such that no two of them intersect? What do you think is the minimum number of points of intersection of three lines?
4. a. Draw any four points J, K, L, and M in your notebook. Make sure that no three of the four points are on a straight line.
- b. Draw \overleftrightarrow{JM} , \overleftrightarrow{JK} , \overleftrightarrow{KL} , and \overleftrightarrow{LM} .
- c. $\overleftrightarrow{JK} \cap \overleftrightarrow{LK} = ?$; $\overleftrightarrow{KL} \cap \overleftrightarrow{ML} = ?$; $\overleftrightarrow{ML} \cap \overleftrightarrow{MJ} = ?$; $\overleftrightarrow{MJ} \cap \overleftrightarrow{JK} = ?$
- d. Do \overleftrightarrow{MJ} and \overleftrightarrow{KL} intersect in a point? Do \overleftrightarrow{ML} and \overleftrightarrow{JK} ?
If only two lines intersect at a point, what is the maximum number of points of intersection of four lines?
- e. Is it possible to have four lines such that no two of them intersect? What do you think is the minimum number of points of intersection of four lines?
5. Given the following picture:

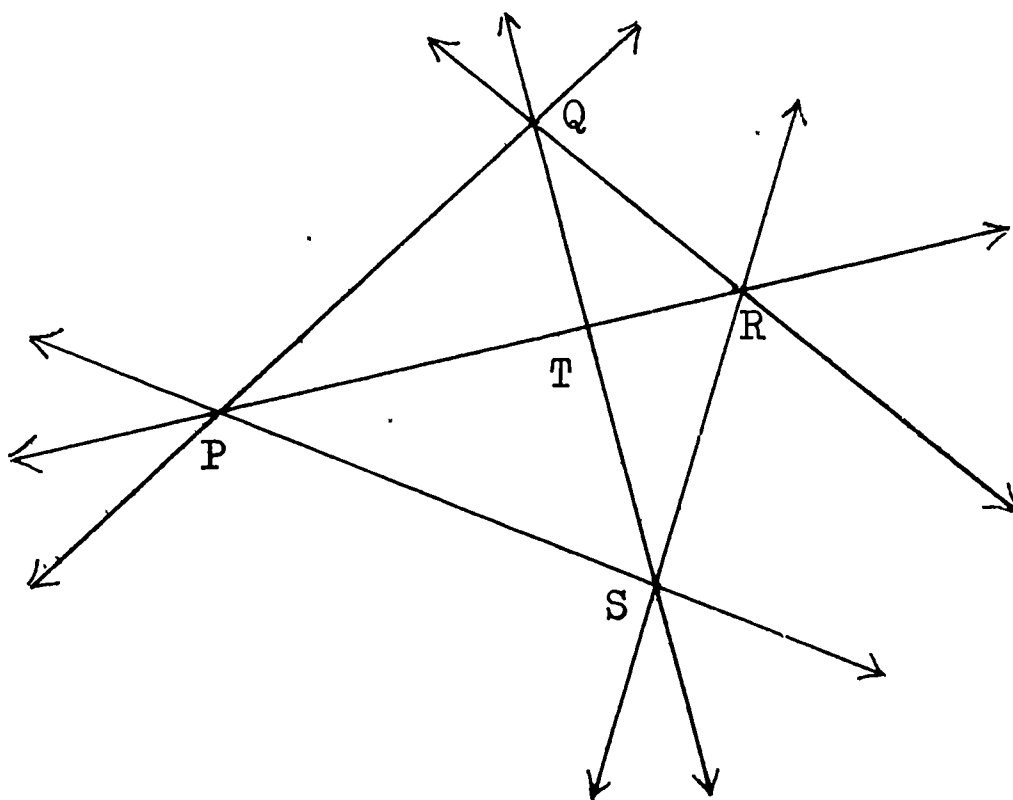

a. $\overleftrightarrow{PQ} \cap \overleftrightarrow{QR} = ?$

d. $\overleftrightarrow{PQ} \cap \overleftrightarrow{PR} \cap \overleftrightarrow{PS} = ?$

b. $\overleftrightarrow{QR} \cap \overleftrightarrow{SQ} = ?$

e. $\overleftrightarrow{PS} \cap \overleftrightarrow{SQ} \cap \overleftrightarrow{RS} = ?$

c. $\overleftrightarrow{PT} \cap \overleftrightarrow{TR} = ?$

6. a. Make the following drawing in your notebook:

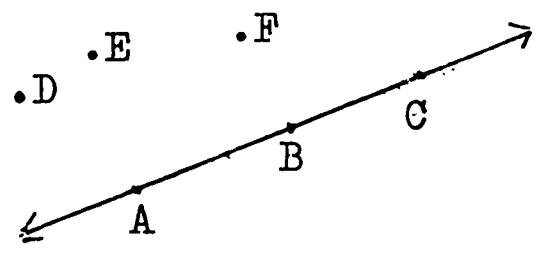

- b. Draw all lines which contain two of the named points.
- c. How many lines have you drawn in part (b) above ?

7. Give five different names for this line:

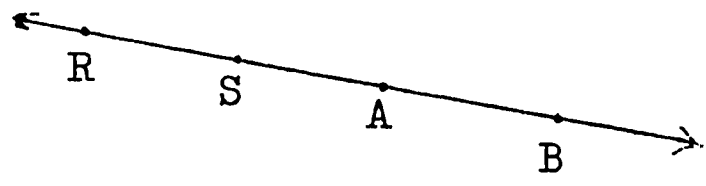

8. a. Copy this figure into your notebook.

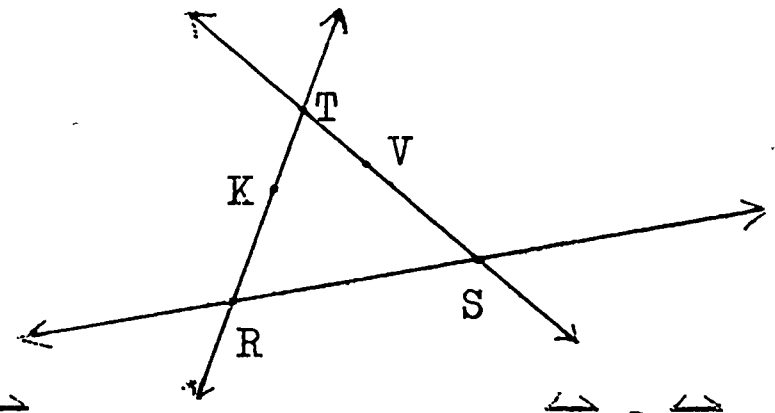

- b. Draw \overleftrightarrow{KS} .
- c. Draw \overleftrightarrow{RV} .
- d. Write two different names for \overleftrightarrow{TS} .
- e. $\overleftrightarrow{KV} \cap \overleftrightarrow{TR} = ?$
- f. $\overleftrightarrow{KV} \cap \overleftrightarrow{RS} = ?$

1-4 What is a Line Segment ?

Here is a picture of a line segment AB:

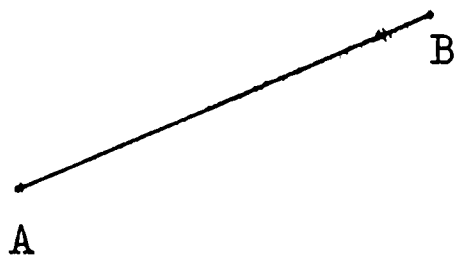

Notice in figure (1) that the line segment AB stops at points A and B. The line segment AB is the set of all points between A and B, including the points A and B. We call A and B the endpoints of the line segment AB.

Let us agree to write " \overline{AB} " for "line segment AB". Hence, \overline{AB} means "the set of all points on the line between A and B, including points A and B."

Using set notation, we may write:

$$\overline{AB} = \left\{ \begin{array}{l} \text{all points on the line between A and B,} \\ \text{including points A and B} \end{array} \right\}$$

Notice that " $\overline{\quad}$ " has no arrows. This symbol reminds us that the line segment stops at points A and B. Also, if we write the words "line segment AB", then we do not need to place the " $\overline{\quad}$ " over AB. If we write " \overline{AB} ", then we mean "line segment AB". We shall not write "line segment \overline{AB} ". Also, we shall not write simply "AB".

In figure (1), the line segment AB and the line segment BA both contain the same points. Is $\overline{AB} = \overline{BA}$?

Now consider \overline{CD} on which E is between C and D, as in this picture:

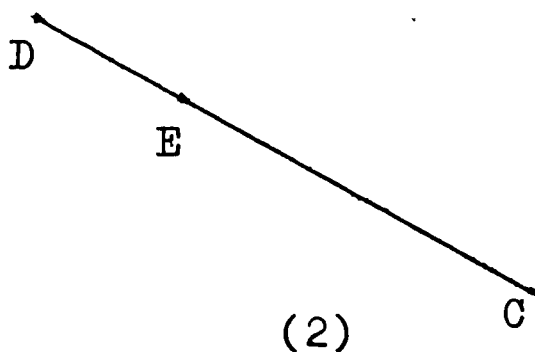

In Section 1-3, we said that if C is a point on \overleftrightarrow{AB} , then \overleftrightarrow{AC} , \overleftrightarrow{AB} , and \overleftrightarrow{BC} are names for the same line. Hence, $\overleftrightarrow{AB} = \overleftrightarrow{BC} = \overleftrightarrow{AC}$.

In figure (2) above, do you think that \overline{CE} , \overline{ED} , and \overline{CD} contain the same set of points? Are \overline{CE} , \overline{ED} , and \overline{CD} names

for the same line segment? Is $\overline{CE} = \overline{ED} = \overline{CD}$? Why?

Recall that for any two sets P and Q , P union Q is the set of all elements in either P or Q . We write " $P \cup Q$ " for " P union Q ".

In figure (2), \overline{CE} and \overline{ED} are sets of points. The union of \overline{CE} and \overline{ED} is \overline{CD} . Do you agree? We may write:

$$\overline{CE} \cup \overline{ED} = \overline{CD} .$$

Here are other examples using intersection and union of line segments in figure (2) :

$$\overline{CE} \cap \overline{ED} = \{E\}$$

$$\overline{CD} \cap \overline{ED} = \overline{ED}$$

$$\overline{CE} \cup \overline{CD} = \overline{CD}$$

Now consider the two line segments \overline{FG} and \overline{HI} , as in this picture:

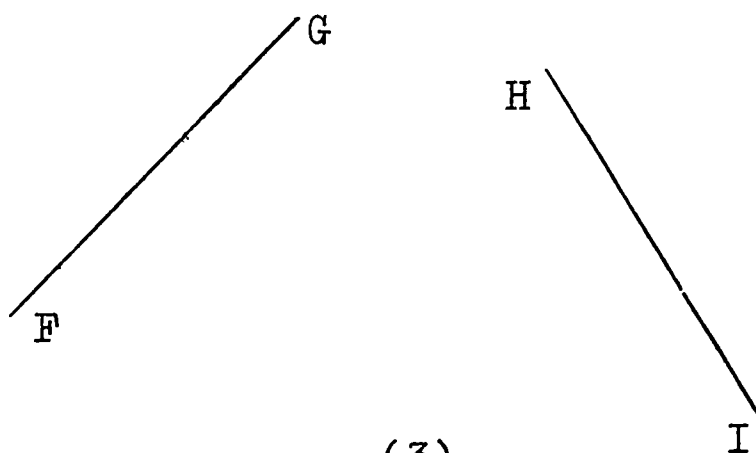

(3)

Can we say that \overline{FG} and \overline{HI} have any points in common in figure (3)?

Recall that the empty set \emptyset is that set which contains no elements. Since \overline{FG} and \overline{HI} in figure (3) do not intersect, then they have no point in common. Hence, we may write:

$$\overline{FG} \cap \overline{HI} = \emptyset$$

Now consider two line segments \overline{JK} and \overline{KL} , where K is on both \overline{JK} and \overline{KL} . The picture could look like this:

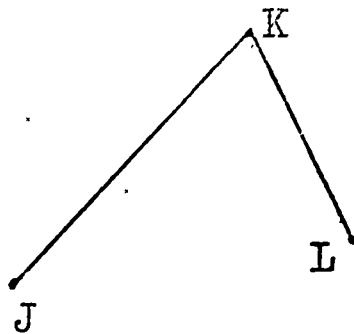

(4)

In figure (4), do you agree that $\overline{JK} \cap \overline{KL} = \{K\}$?

However, $\overline{JK} \cup \overline{KL} \neq \overline{JL}$, because J , K , and L are not on the same straight line in figure (4) .

(1) A picture of a line segment AB looks like this:



(2) The symbol for "line segment AB " is " \overline{AB} ".

(3) $\overline{AB} = \left\{ \begin{array}{l} \text{all points between } A \text{ and } B, \\ \text{including points } A \text{ and } B \end{array} \right\}$

Exercises 1-4

1. a. Draw any two points A and B .
- b. Draw \overline{AB} .
- c. Draw \overleftrightarrow{AB} .
- d. Is every point on \overline{AB} also on \overleftrightarrow{AB} ? Is \overline{AB} a subset of \overleftrightarrow{AB} ? Is $\overleftrightarrow{AB} \subset \overline{AB}$?

2. a. Draw any two points Q and R.
 b. Draw \overline{QR} .
 c. Let S be a point on \overline{QR} .
 d. Is \overline{QS} another name for \overline{QR} ? Is \overline{SR} another name for \overline{QR} ?
 e. Draw \overleftrightarrow{QR} .
 f. Is \overleftrightarrow{QS} another name for \overleftrightarrow{QR} ? Is \overleftrightarrow{SR} another name for \overleftrightarrow{QR} ?

3. a. Draw any two points C and D.
 b. Draw \overline{CD} .
 c. Let E be any point on \overline{CD} .
 d. $\overline{CE} \cup \overline{ED} = ?$
 e. $\overline{CE} \cap \overline{ED} = ?$
 f. $\overline{CD} \cap \overline{ED} = ?$
 g. $\overline{CD} \cap \overline{CE} = ?$

4. Given the following picture:

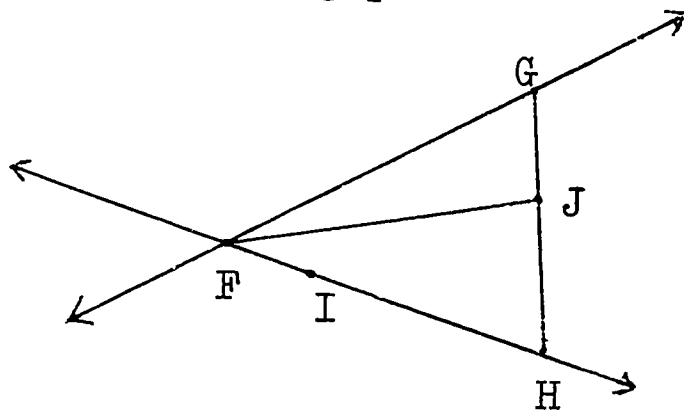

- a. $\overleftrightarrow{FG} \cap \overleftrightarrow{FH} = ?$
 b. $\overleftrightarrow{FI} \cap \overleftrightarrow{FH} = ?$
 c. $\overline{FI} \cap \overline{FH} = ?$
 d. $\overline{FJ} \cap \overline{FI} = ?$
 e. $\overline{FI} \cup \overline{IH} = ?$
 f. $\overline{FI} \cup \overline{IH} = ?$
 g. Is $\overline{FH} \cup \overline{JH} = \overline{FJ}$?
 h. Is $\overline{GJ} \cup \overline{JH} = \overline{GH}$?
5. Follow the directions and draw the figure in your notebook:
 a. Draw any two points K and L.
 b. Draw \overleftrightarrow{KL} .
 c. Draw a point M on one side of \overleftrightarrow{KL} , and a point N on the opposite side of \overleftrightarrow{KL} from M.
 d. Draw \overline{MN} . Let the point of intersection of \overline{MN} and \overleftrightarrow{KL} be point P.

e. Is $\{P\} \subset \overleftrightarrow{KL}$? Is $\{P\} \subset \overleftrightarrow{MN}$?

f. Draw \overline{ML} , \overline{LN} , \overline{NK} , and \overline{KM} .

6. Draw two line segments PQ and RS so that they intersect at T.

a. Write one name for each line segment in your picture.

b. $(\overline{PT} \cap \overline{TQ}) \cup \overline{RT} = ?$

c. $(\overline{RT} \cup \overline{ST}) \cap \overline{QP} = ?$

7. Given the following figure:

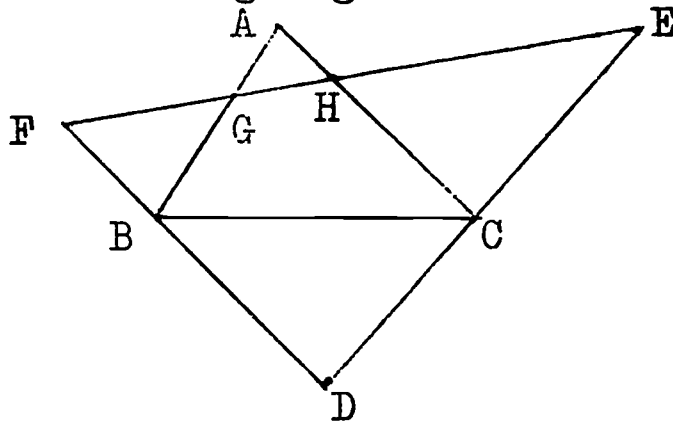

a. Write one name for each line segment in the figure.

b. $\overline{BG} \cap \overline{GH} = ?$

e. $\overline{AH} \cup \overline{HC} = ?$

c. $\overline{FE} \cap \overline{BC} = ?$

f. $\overline{FB} \cap \overline{DF} = ?$

d. $\overline{BD} \cap \overline{EC} = ?$

g. $\overline{BG} \cup \overline{GA} = ?$

1-5 Measure of Line Segments

You learned in the previous Section that a line segment AB is the set of all points between A and B, including A and B.

In this Section, we want to learn about the measure of a line segment. We want to be able to answer such questions as: "How long is the line segment AB?" and "Which one of two line segments AB and CD is longer?"

For example, look at these two line segments:

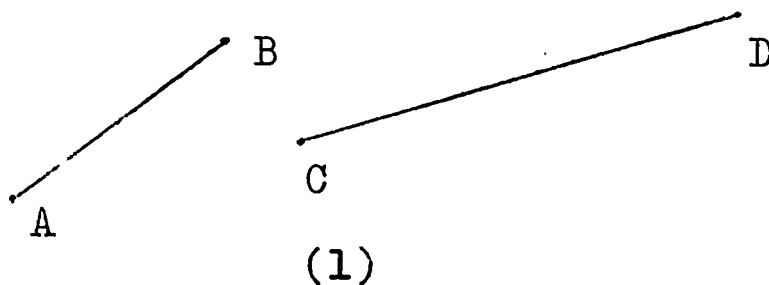

Which one of the line segments in figure (1) is longer? You would probably say that \overline{CD} is longer than \overline{AB} . Why? Your reason might be: "I can see that \overline{CD} is longer than \overline{AB} ". Now which one of these two line segments is longer?

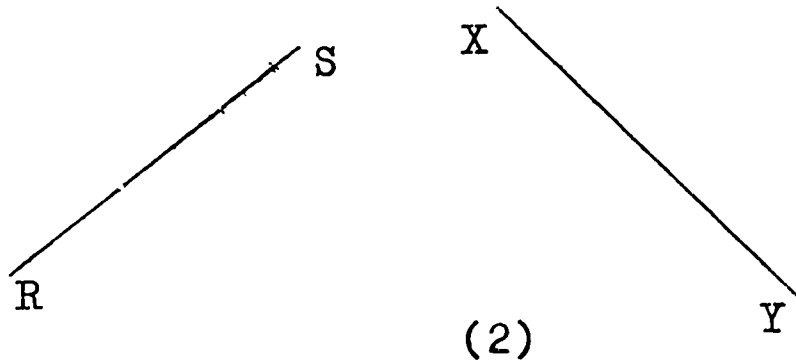

You cannot simply look at the two line segments \overline{RS} and \overline{XY} and decide which one is longer. You need an instrument to help you measure each line segment. You can then compare the two measures. Then you can decide which one of \overline{RS} and \overline{XY} is longer. The instrument you need is a ruler.

Here is a picture of a ruler:

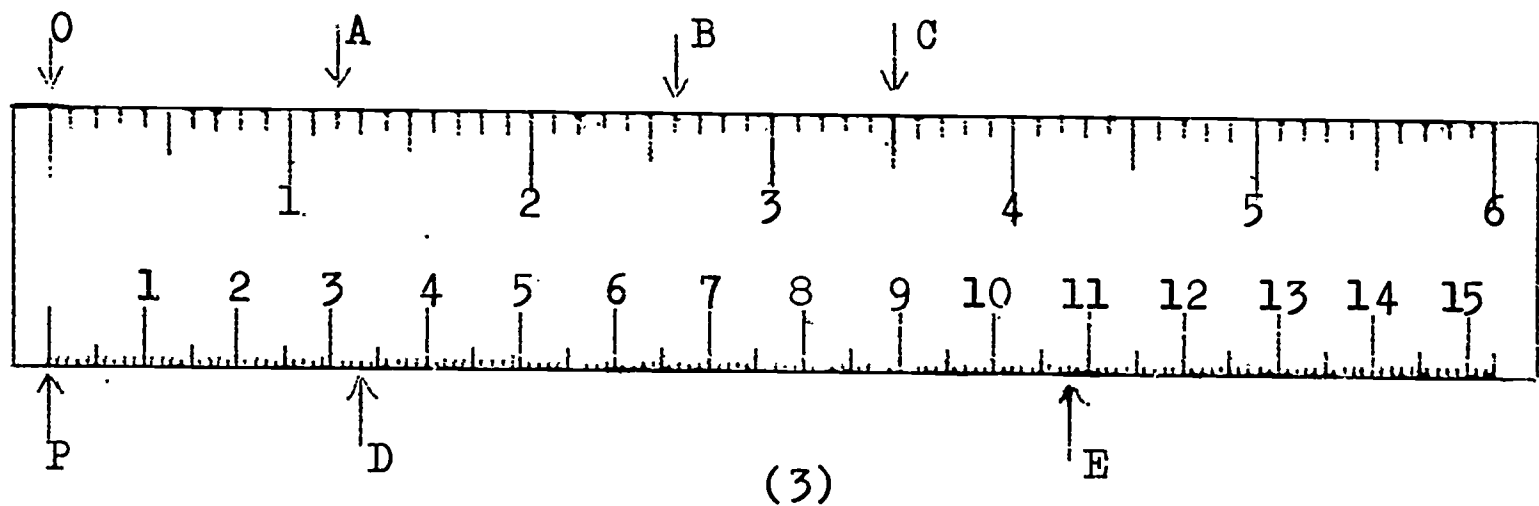

The top edge of the ruler in figure (3) is marked in inches. Notice that in figure (3), each inch is divided into 10 equal parts. Each of these equal parts is called one-tenth of an inch. The mark labelled A is 1.2 inches from the mark labelled 0. Notice that the mark labelled 0 is not at the end of the ruler in figure (3). The mark B is 2.6 inches from the mark 0. The mark C is 3.5 inches from the mark 0.

If we had a ruler with 12 inches marked on it, then that ruler would be one foot long. If we had a ruler with 36 inches marked on it, then that ruler would be one yard long. Each yard contains 3 feet. How many inches does one yard contain ?

With your ruler, measure line segment \overline{RS} in figure (2) to the nearest tenth of an inch. If you measure accurately, you will find that the length of \overline{RS} is 1.5 inches.

We write: $m \overline{RS} = 1.5$.

We say: " The measure of the line segment \overline{RS} is 1.5, where the unit of measure is one inch ". We also say: " The line segment \overline{RS} is 1.5 inches long ".

Notice that $m \overline{RS}$ is a number. When we write " $m \overline{RS}$ ", we are thinking of a number. The number is associated with the length of the line segment \overline{RS} . But when we write " \overline{RS} ", we are thinking of the line segment \overline{RS} itself.

(1) $m \overline{RS}$ is a number.

(2) \overline{RS} is a line segment.

In figure (2), if you measure \overline{XY} accurately, using one inch as a unit of measure, you will find that $m \overline{XY} = 1.7$.

Now which one of the two line segments \overline{XY} and \overline{RS} is longer ? We can compare the numbers 1.5 and 1.7 .

Is $1.5 > 1.7$? Is $1.5 = 1.7$? We know that $1.5 < 1.7$. Since $m \overline{RS} = 1.5$, and $m \overline{XY} = 1.7$, then $m \overline{RS} < m \overline{XY}$.

Notice that exactly one of the following statements is true:

(1) $m \overline{RS} < m \overline{XY}$

(2) $m \overline{RS} = m \overline{XY}$

(3) $m \overline{RS} > m \overline{XY}$

For any two line segments AB and CD ,
exactly one of the following is true:

$$(1) \quad m \overline{AB} < m \overline{CD}$$

$$(2) \quad m \overline{AB} = m \overline{CD}$$

$$(3) \quad m \overline{AB} > m \overline{CD}$$

Let us again look at the picture of the ruler in figure (3). The bottom edge of the ruler is marked in centimetres. Notice the numerals 1, 2, 3, ..., 15 marked on the bottom edge of this ruler. Each of these numerals indicates the number of centimetres from the point marked P to that given numeral. For example, the numeral 6 means that there are 6 centimetres from P to the mark at 6. We often write "cm." for "centimetres". Thus, "6 centimetres" can be written "6 cm."

If we had a ruler with 100 centimetres marked on it, then that ruler would be one metre long. The word centimetre means one-hundredth of a metre. Therefore, one metre contains 100 centimetres.

Notice that there are smaller marks between any two centimetre marks on the ruler in figure (3). Each of these smaller marks contains one millimetre. Each centimetre contains 10 millimetres. Since one metre contains 100 centimetres, then one metre contains $100 \times 10 = 1000$ millimetres. Hence, one millimetre is one-thousandth of a metre.

In figure (3), the mark labelled D is 3.3 centimetres, or 33 millimetres, from the mark labelled P. The mark labelled E is 10.8 centimetres, or 108 millimetres, from P.

Now measure the line segments RS and XY in figure (2) again. This time use one centimetre as your unit of measure, and measure to the nearest tenth of a centimetre. If you measure

accurately, you will find that $m \overline{RS} = 3.8$ and $m \overline{XY} = 4.3$. We say: " \overline{RS} is 3.8 centimetres long", and " \overline{XY} is 4.3 centimetres long". We also say: "The measure of line segment \overline{RS} is 3.8, where the unit of measure is one centimetre", and "The measure of line segment \overline{XY} is 4.3, where the unit of measure is one centimetre".

Notice again that $m \overline{RS}$ and $m \overline{XY}$ are numbers. Since $3.8 < 4.3$, we can conclude that $m \overline{RS} < m \overline{XY}$. Is $m \overline{RS}$ less than $m \overline{XY}$ when we measure in inches? Is $m \overline{RS}$ less than $m \overline{XY}$ when we measure in centimetres? Does changing the unit of measure change the relationship between $m \overline{RS}$ and $m \overline{XY}$?

Exercises 1-5

1. Measure each of the following line segments:

- a. to the nearest tenth of an inch.
- b. to the nearest millimetre.

- i. A _____ B
- ii. C _____ D
- iii. E _____ F
- iv. G _____ H
- v. I _____ J

- c. Arrange your measures of the line segments above in order, from the smallest measure to the largest. Use the inequality symbol.
- d. Are your measures in the same order when you measure in centimetres as when you measure in inches?

2. Given the following figure. Find the measurements which are asked for, and then record these measures in your notebook.

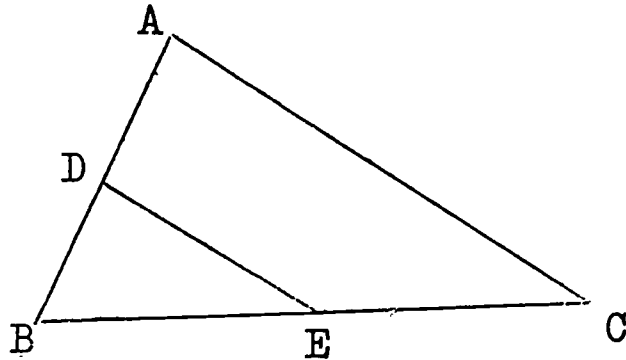

- $m \overline{AD} = ?$; $m \overline{DB} = ?$; Is $m \overline{AD} = m \overline{DB}$?
 - $m \overline{BE} = ?$; $m \overline{EC} = ?$; Is $m \overline{BE} = m \overline{EC}$?
 - $m \overline{DE} = ?$; $m \overline{AC} = ?$
 - What do you notice about $m \overline{DE}$ and $m \overline{AC}$ in part (c) above ?
3. Given the following figure. Find the measurements which are asked for, and then record these measures in your notebook.

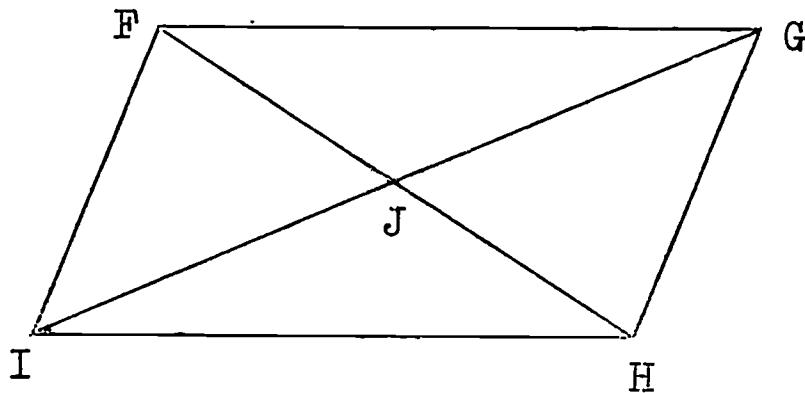

- $m \overline{FG} = ?$; $m \overline{IH} = ?$; What do you notice about these two measures ?
- $m \overline{IF} = ?$; $m \overline{GH} = ?$; What do you notice about these two measures ?
- $m \overline{IJ} = ?$; $m \overline{JG} = ?$; What do you notice about these two measures ?
- $m \overline{FJ} = ?$; $m \overline{JH} = ?$; What do you notice about these two measures ?

4. Given the following figure. Find the measures which are asked for, and then record these measures in your notebook.

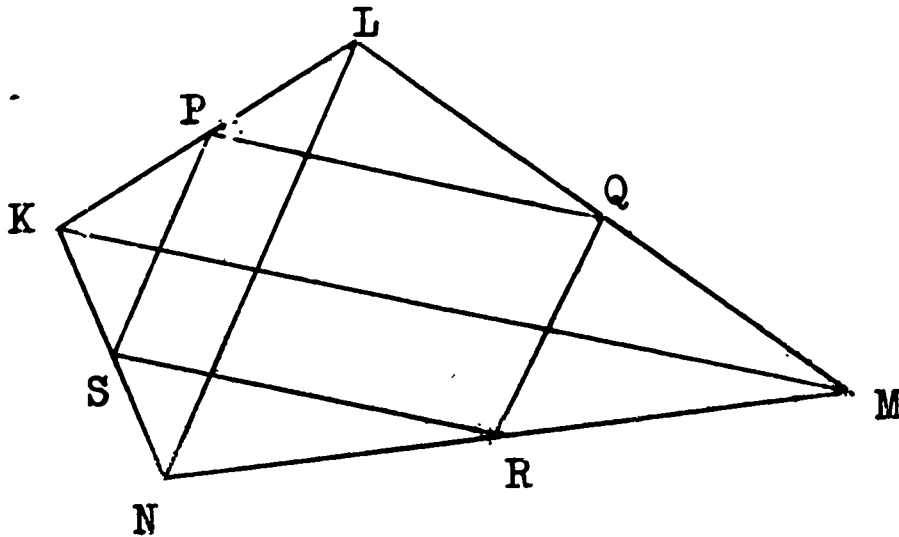

- a. $m \overline{KP} = ?$; $m \overline{PL} = ?$; Is $m \overline{KP} = m \overline{PL}$? Is $m \overline{KP} = (m \overline{KL}) \div 2$?
- b. $m \overline{LQ} = ?$; $m \overline{QM} = ?$; Is $m \overline{LQ} = m \overline{QM}$?
Is $2 \times (m \overline{LQ}) = m \overline{LM}$?
- c. $m \overline{MR} = ?$; $m \overline{RN} = ?$; Is $m \overline{NR} = (m \overline{NM}) \div 2$?
- d. $m \overline{NS} = ?$; $m \overline{SK} = ?$; What do you notice about these two measures ? What do you think is true about $m \overline{SN}$ and $m \overline{KN}$?
- e. $m \overline{PQ} = ?$; $m \overline{RS} = ?$; What do you notice about these two measures ?
- f. $m \overline{PS} = ?$; $m \overline{QR} = ?$; What do you notice about these two measures ?
- g. $m \overline{KM} = ?$; What do you notice about $m \overline{PQ}$ and $m \overline{KM}$? ;
What do you notice about $m \overline{SR}$ and $m \overline{KM}$?
- h. $m \overline{LN} = ?$; What do you notice about $m \overline{PS}$ and $m \overline{LN}$?
What do you notice about $m \overline{QR}$ and $m \overline{LN}$?

1-6 What is a Ray ?

Let C be a point on the line AB as shown in this figure:

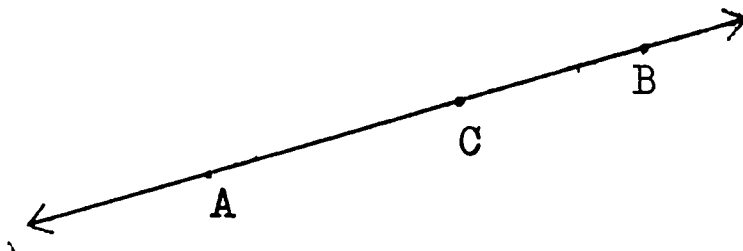

(1)

In figure (1), let us call the set of all points to the right of point C a half-line. The set of all points to the left of point C is another half-line.

The point C separates the line AB into three subsets:

- (1) { all points on the half-line of \overleftrightarrow{AB} }
 { which contains the point B }
- (2) { C }
- (3) { all points on the half-line of \overleftrightarrow{AB} }
 { which contains the point A }

Is the point C on either half-line ?

The union of point C and the half-line of \overleftrightarrow{AB} containing point B is called ray CB . Here is a picture of ray CB :

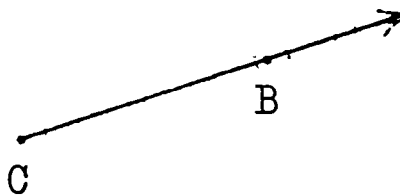

(2)

Let us agree to write " \overrightarrow{CB} " for "ray CB ". Notice the " \overrightarrow " over CB . This " \overrightarrow " reminds us that the ray CB

begins at point C and extends infinitely through point B.

If we write \overrightarrow{BC} , we would mean the ray beginning at point B and extending infinitely through point C. \overrightarrow{BC} would look like this:

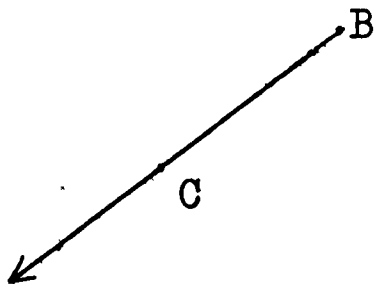

(3)

Do you think that $\overrightarrow{BC} = \overrightarrow{CB}$?

Now consider a point F on ray DE, as in this picture:

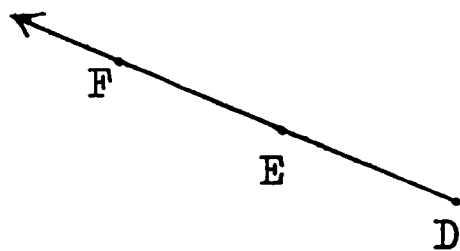

(4)

In figure (4), the set of points of ray DE is the same as the set of points of ray DF. Hence, $\overrightarrow{DE} = \overrightarrow{DF}$. What is $\overrightarrow{DE} \cap \overrightarrow{DF}$? What is $\overrightarrow{DE} \cup \overrightarrow{DF}$?

However, in figure (4), $\overrightarrow{DF} \neq \overrightarrow{EF}$, because \overrightarrow{DF} contains the point D, but \overrightarrow{EF} does not contain the point D. Do you agree? What is $\overrightarrow{DE} \cap \overrightarrow{EF}$? What is $\overrightarrow{DE} \cup \overrightarrow{EF}$?

Consider two different rays, \overrightarrow{GH} and \overrightarrow{JK} , as in this picture:

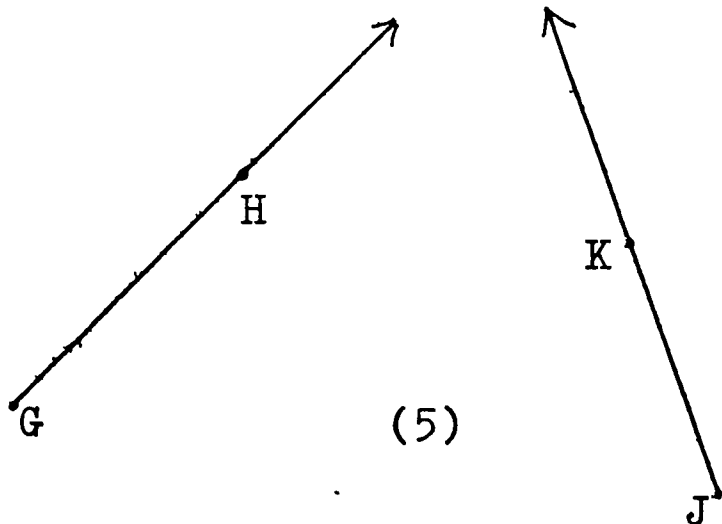

(5)

Since G , H , J , and K are four different points in figure (5), then \overrightarrow{GH} and \overrightarrow{JK} are different rays.

Now let the endpoint of two rays be the same point. For example, let two rays be \overrightarrow{LM} and \overrightarrow{LN} , where L is the endpoint of both \overrightarrow{LM} and \overrightarrow{LN} . The picture could look like this:

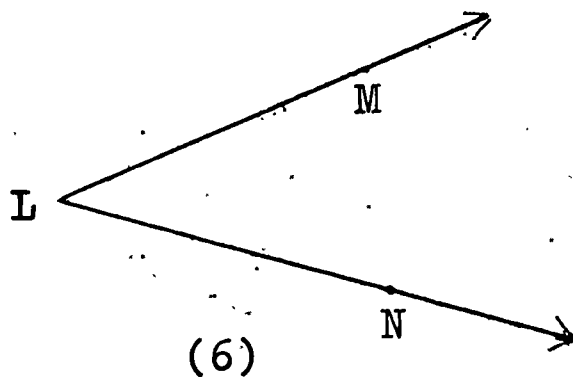

Notice that figure (6) represents the union of two rays with a common endpoint. We shall discuss the union of two rays with a common endpoint in the next Section. In figure (6), what is $\overrightarrow{LM} \cap \overrightarrow{LN}$?

(1) A picture of a ray AB looks like this:

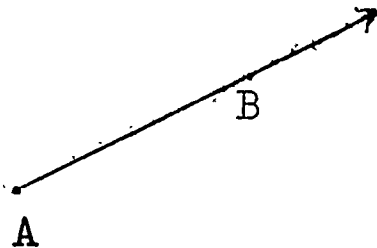

(2) The symbol for "ray AB " is " \overrightarrow{AB} ".

(3) \overrightarrow{AB} is the union of the point A and the half-line containing point B .

Exercises 1-6

1. Name the three sets into which a point P separates a line QR .

2. In Exercise (1), the ray \overrightarrow{PR} is the union of _____ and the _____ which contains the point R.

3. Given the following figure:

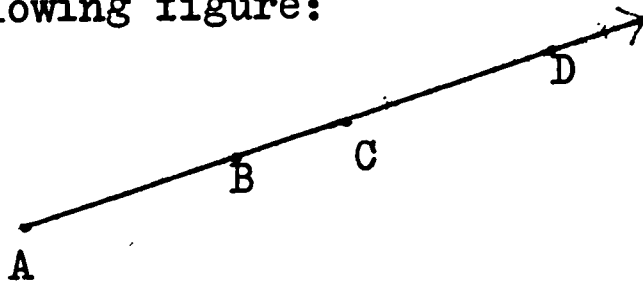

a. Write four names for the ray in the figure above.

b. Is $\overrightarrow{AB} = \overrightarrow{AC}$? ; Is $\overrightarrow{AC} = \overrightarrow{AD}$? Why ?

c. Is $\overline{AB} = \overline{AC}$? ; Is $\overline{AC} = \overline{AD}$? Why ?

d. Is $\overline{AB} \subset \overline{AC}$? ; Is $\overline{AB} \subset \overline{AD}$? Why ?

e. Is $\overline{AC} \subset \overline{BD}$? ; Is $\overline{AC} \subset \overline{AD}$? Why ?

f. $\overline{AB} \cap \overline{AC} = ?$; $\overline{AB} \cup \overline{AC} = ?$

g. $\overrightarrow{AB} \cap \overrightarrow{BC} = ?$; $\overrightarrow{AB} \cup \overrightarrow{BC} = ?$

h. $\overline{AB} \cap \overline{AC} = ?$; $\overline{AB} \cup \overline{AC} = ?$

i. $\overline{AB} \cap \overline{CD} = ?$; $\overline{AB} \cap \overline{AD} = ?$

j. $\overline{AB} \cup \overline{BD} = ?$; $\overline{AB} \cap \overline{BD} = ?$

4. Given the following figure:

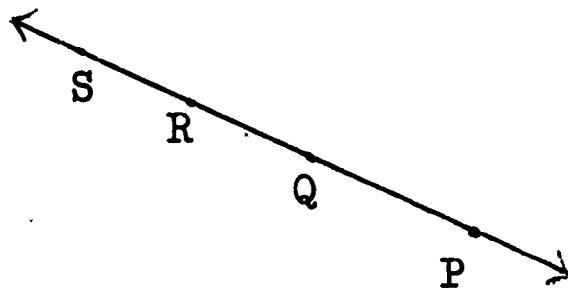

a. $\overrightarrow{QP} \cup \overrightarrow{QS} = ?$

f. $\overline{PQ} \cup \overline{QR} = ?$

b. $\overline{QR} \cap \overline{QP} = ?$

g. $\overrightarrow{PQ} \cup \overrightarrow{QR} = ?$

c. $\overrightarrow{QS} \cap \overrightarrow{RP} = ?$

h. $\overline{QR} \cup \overline{QP} = ?$

d. $\overrightarrow{RS} \cap \overrightarrow{QP} = ?$

i. $\{Q\} \cup \overrightarrow{QP} = ?$

e. $\overline{RP} \cup \overline{QS} = ?$

j. $\{Q\} \cap \overrightarrow{QP} = ?$

5. Given the following figure. Use this figure to answer all parts of this Exercise. Write your answers in your notebook.

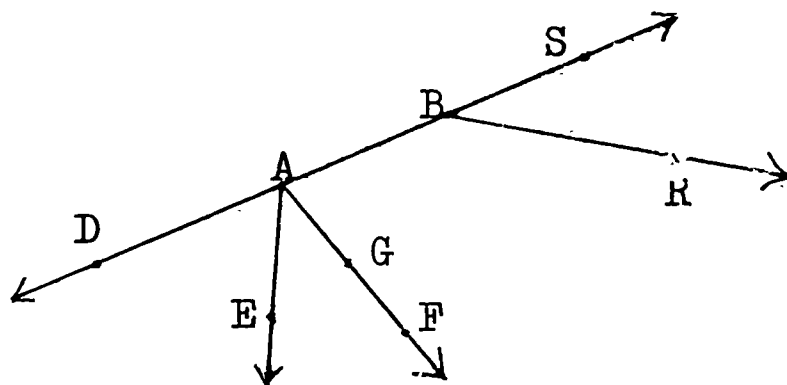

- Name four rays in the figure above.
- Write four other names for \overrightarrow{AB} .
- $\overline{AE} \cap \overline{AF} = ?$
- $\overline{AB} \cup \overline{AD} = ?$
- $\overrightarrow{AB} \cap \overrightarrow{BA} = ?$
- $\overline{AE} \cap \overline{GF} = ?$
- $\overline{BS} \cap \overline{BR} = ?$
- $\overrightarrow{AD} \cup \overrightarrow{AS} = ?$
- $\overrightarrow{AB} \cap \overrightarrow{GF} = ?$
- $\overrightarrow{AG} \cup \overrightarrow{GF} = ?$
- $\overrightarrow{DA} \cap \overline{BA} = ?$
- $\overrightarrow{DS} \cup \overline{BA} = ?$

6. Given the following figure:

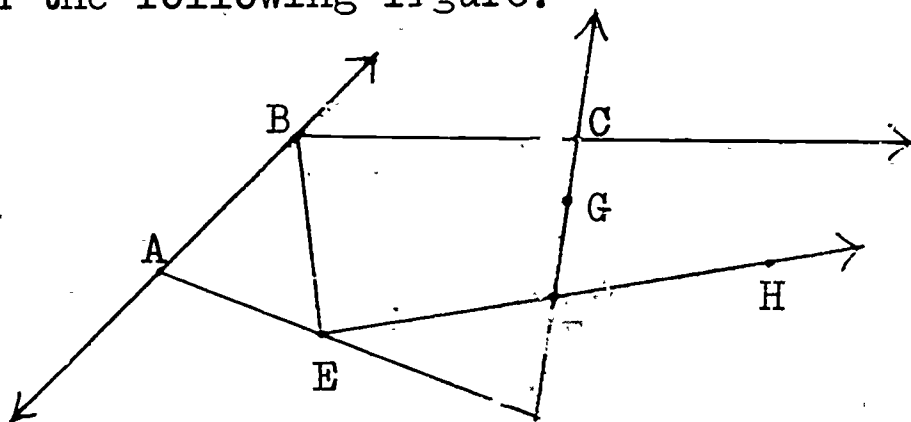

- $\overrightarrow{BC} \cap \overrightarrow{FC} = ?$
- $\overrightarrow{AB} \cap \overline{AB} = ?$
- $\overline{DF} \cup \overrightarrow{FC} = ?$
- $\overline{EF} \cap \overline{FD} = ?$
- $\overline{CG} \cup \overline{GF} = ?$
- $\overrightarrow{GC} \cup \overline{GD} = ?$
- $\overline{AE} \cap \overline{AD} = ?$
- $\overline{AB} \cap \overline{FG} = ?$
- $\overline{FH} \cap \overrightarrow{GC} = ?$
- $\overline{CG} \cup \overline{GF} = ?$

1-7 What is an Angle ?

Recall from Section 1-6 that a ray AB is the union of point A and the half-line containing point B.

Let us draw two rays AB and AC, where A is a common endpoint, as in this figure:

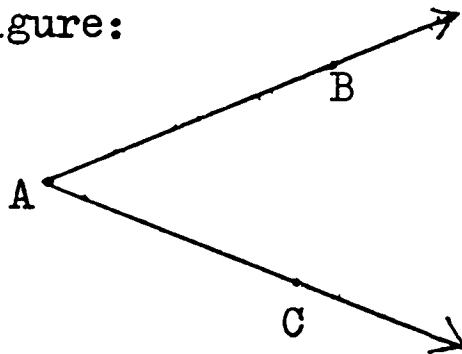

(1)

Figure (1) is called an angle. An angle is the union of two rays with a common endpoint. When we speak of angle BAC in figure (1), we shall write $\angle BAC$, or \widehat{BAC} . The symbols " \angle " and " $\widehat{}$ " mean "angle". We read " $\angle BAC$ " as "angle BAC". Another name for $\angle BAC$ is $\angle CAB$.

Since angle BAC is the union of two rays AB and AC, we may write:

$$\overrightarrow{AB} \cup \overrightarrow{AC} = \angle BAC .$$

The point A is called the vertex of $\angle BAC$. When we write $\angle BAC$, we write the letter A associated with the vertex point between the two letters B and C. The rays AB and AC are called the sides of $\angle BAC$.

Look at the following picture:

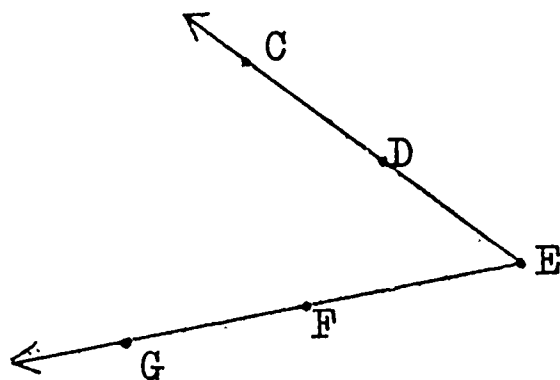

(2)

In figure (2), there is only one angle. However, there are many names for that angle. For example, some names for the angle in figure (2) are: $\angle CEG$, $\angle FEC$, $\angle DEG$, and $\angle FED$. Notice again that the vertex point E is between the other two points in each name for the angle in figure (2).

Since an angle is a set of points, and since the set of points in figure (2) is one angle, then we can write:

$$\angle CEG = \angle FEC = \angle DEG = \angle FED .$$

Look at this picture of a line JK with any point L on \overleftrightarrow{JK} between J and K:

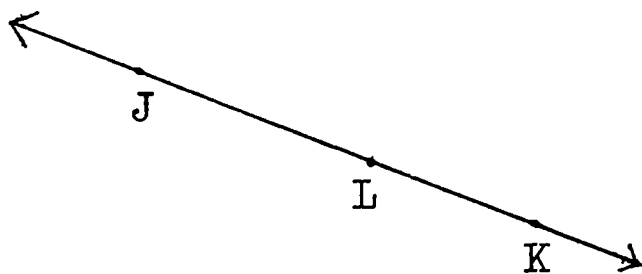

(3)

We may think of figure (3) as an angle. \overrightarrow{LJ} is a ray, and \overrightarrow{LK} is a ray. Point L is the common endpoint. Hence,

$$\overrightarrow{LJ} \cup \overrightarrow{LK} = \angle JLK$$

$\angle JLK$ in figure (3) is a special angle. Since $\angle JLK$ forms a straight line, we call $\angle JLK$ a straight angle. The rays LJ and LK are in opposite directions on the line JK.

- (1) Angle ABC is the union of the two rays BA and BC with the common endpoint B .
- (2) " $\angle ABC$ " and " \widehat{ABC} " mean "angle ABC ".
- (3) $\overrightarrow{BA} \cup \overrightarrow{BC} = \angle ABC$.
- (4) The common endpoint B of the rays BA and BC is called the vertex of $\angle ABC$.

Exercises 1-7

1. a. Draw a ray AB .
 b. Draw another ray AC .
 c. $\overrightarrow{AB} \cup \overrightarrow{AC} = ?$
 d. $\overrightarrow{AB} \cap \overrightarrow{AC} = ?$

2. Given the following figure:

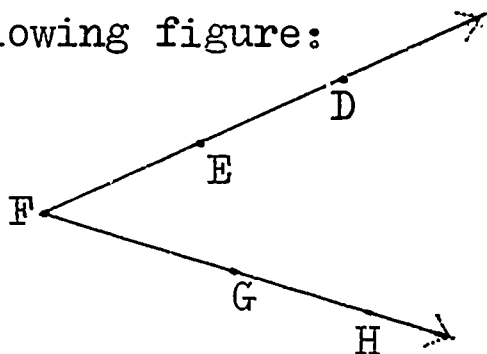

- a. Write eight different names for the angle in the figure.
 b. Is $\angle DFG = \angle EFH$? ; Is $\angle EFG = \angle HFD$?
3. Given the following picture:

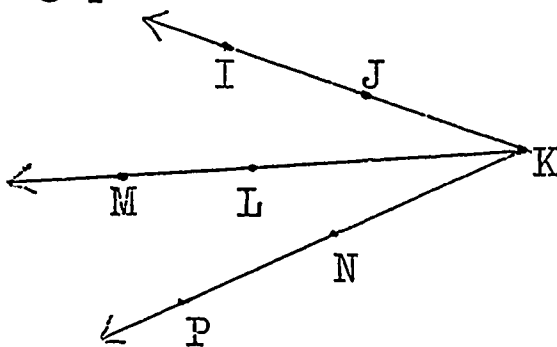

- a. How many different angles are there in the figure ?
- b. Write two names for each of these different angles.
- c. Is $\widehat{JKL} = \widehat{IKN}$? ; Is $\widehat{IKM} = \widehat{JKL}$?

4. Given the following figure:

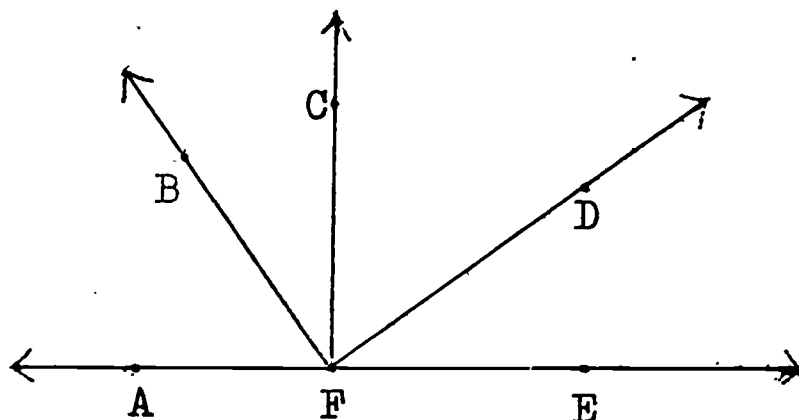

- a. How many different angles are there in the figure ?
 - b. Write one name for each of these different angles.
 - c. $\overrightarrow{FA} \cup \overrightarrow{FE} = ?$; $\overrightarrow{FC} \cup \overrightarrow{FD} = ?$
5. a. Draw a ray OP .
- b. Rotate \overrightarrow{OP} about point O one-fourth of a complete rotation. Label the final position \overrightarrow{OQ} .
- c. Write two different names for the angle so formed.
6. Stand facing the direction of the north.
- a. Which direction will you be facing if you make a quarter of a complete turn to the right ? half of a complete turn to the right ? three-quarters of a complete turn to the right ? one complete turn to the right ?
7. Draw pictures of angles to illustrate your answers in Exercise (6) above . How do you think that you can draw an angle which represents three-fourths of a complete turn to the right ? one complete turn to the right ?

8. Copy the following picture in your notebook. Then answer the questions asked.

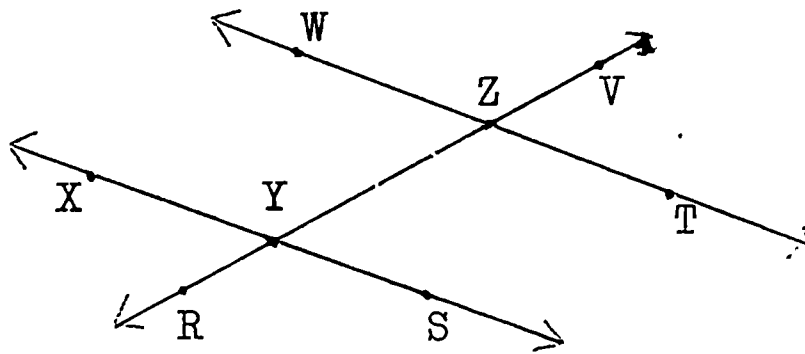

- Draw \overline{RS} on the figure in your notebook.
 - Draw \overleftrightarrow{WX} .
 - Draw \overleftrightarrow{TV} .
 - Name two angles which have Y as a vertex.
 - Name two rays contained in \overleftrightarrow{XS} .
 - Give two different names for \overleftrightarrow{YZ} .
 - $\overrightarrow{YR} \cup \overrightarrow{YS} = ?$
 - $\overrightarrow{WZ} \cup \overrightarrow{ZT} = ?$
 - $\overrightarrow{ZU} \cap \overrightarrow{ZT} = ?$
 - $\overleftrightarrow{WT} \cap \overleftrightarrow{RY} = ?$
 - $\overleftrightarrow{WT} \cup \overleftrightarrow{ZT} = ?$
 - $\overleftrightarrow{WT} \cap \overrightarrow{WZ} = ?$
 - $\overrightarrow{YS} \cup \overrightarrow{YX} = ?$
 - $\overrightarrow{ZT} \cap \overrightarrow{YX} = ?$
9. Follow the directions and draw the figure in your notebook.
- Draw any two points A and B.
 - Draw \overrightarrow{AB} .
 - Measure \overline{AB} and record $m \overline{AB}$ in your notebook.
 - Draw a point C so that C is not on \overrightarrow{AB} , and let $m \overline{AC}$ be equal to $m \overline{AB}$.
 - Draw \overrightarrow{AC} .
 - Name the figure which you have drawn.
 - Draw \overline{BC} .
 - Let D be a point on \overline{BC} so that $m \overline{CD} = m \overline{BD}$.
 - Draw \overrightarrow{AD} .
 - What do you think \overrightarrow{AD} does to $\angle BAC$?

1-8 Measure of Angles

In Section 1-5, you learned how to measure a line segment AB with a ruler. You learned that with a line segment AB , there is associated a number. We call that number the measure of \overline{AB} . We write " $m \overline{AB}$ " to mean "the measure of \overline{AB} ". You also learned that we can compare the lengths of two line segments AB and CD by comparing their measures.

In this Section, we wish to measure angles. We shall answer such questions as: "What is the measure of an angle ABC ?" and "Which one of the two angles ABC and CDE is larger?"

Look at this picture of two angles ABC and DEF :

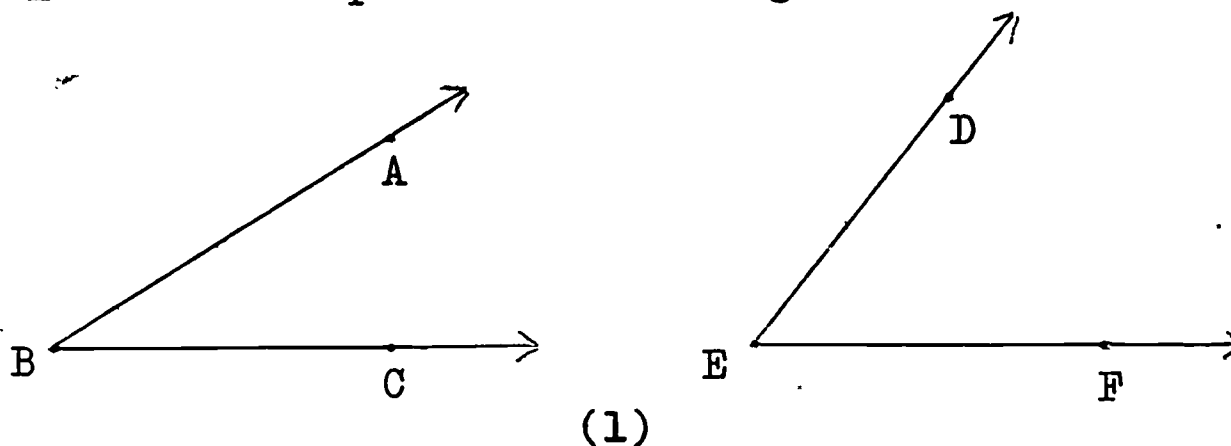

We would like to decide which angle in figure (1) is larger. How can we compare these angles?

Let us consider the amount of rotation of the ray BA from the ray BC in $\angle ABC$, and the amount of rotation of the ray ED from the ray EF in $\angle DEF$, as in this picture:

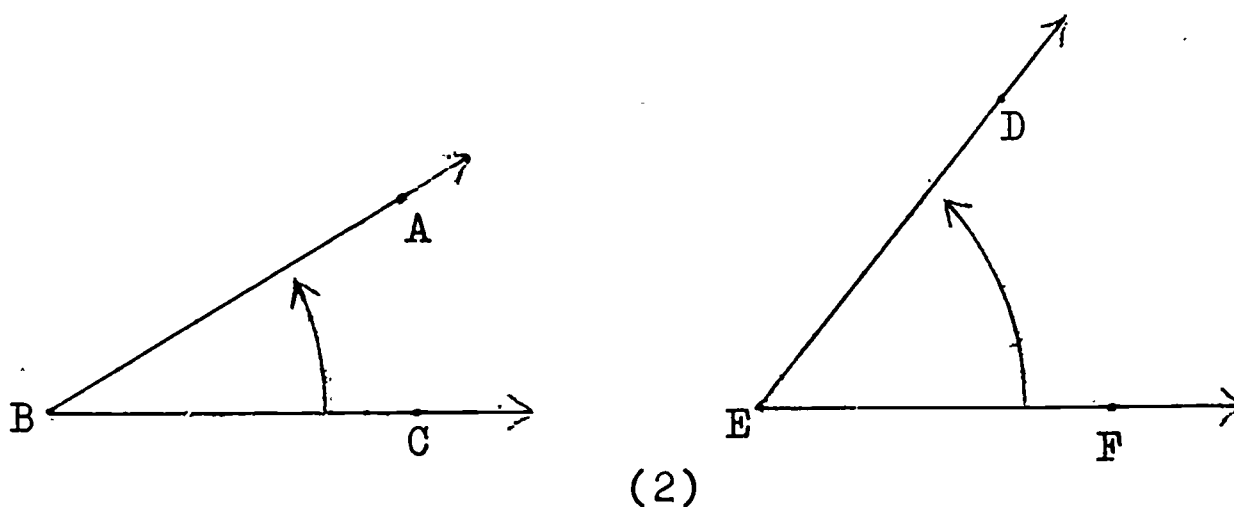

In figure (2), the amount of turning from \overrightarrow{EF} to \overrightarrow{ED} in $\angle DEF$ looks greater than the amount of turning from \overrightarrow{BC} to \overrightarrow{BA} in $\angle ABC$. Do you agree? We think that $\angle DEF$ is greater than $\angle ABC$ in figure (2).

Now look at this picture of two angles:

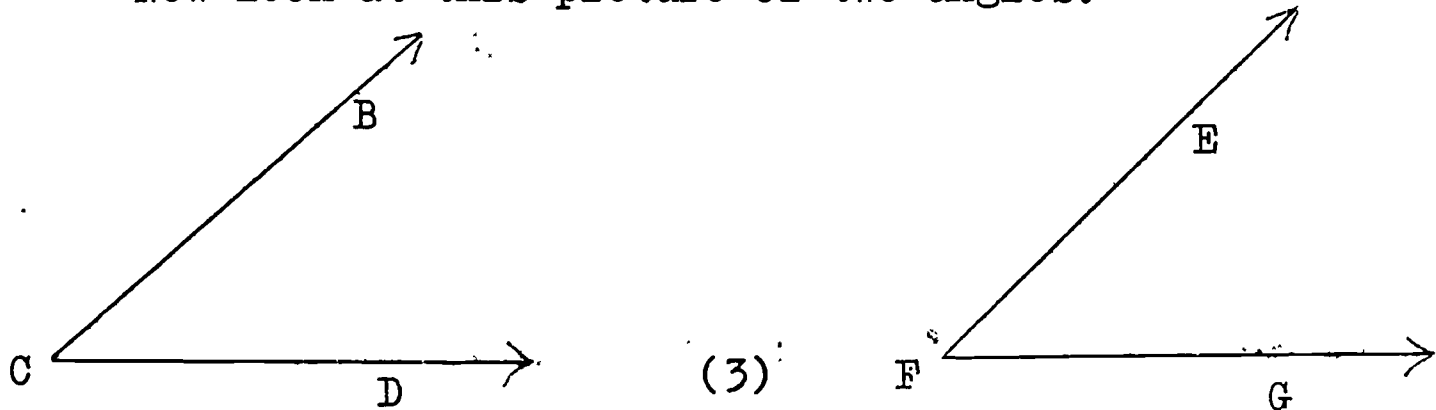

In figure (3), the amount of rotation from \overrightarrow{CD} to \overrightarrow{CB} in $\angle BCD$ looks almost the same as the amount of rotation from \overrightarrow{FG} to \overrightarrow{FE} in $\angle EFG$. We can no longer decide which angle is greater by simply looking at the amount of turning of the rays. We need an instrument to help us measure the amount of rotation. The instrument we need is called a protractor.

Here is a picture of a protractor:

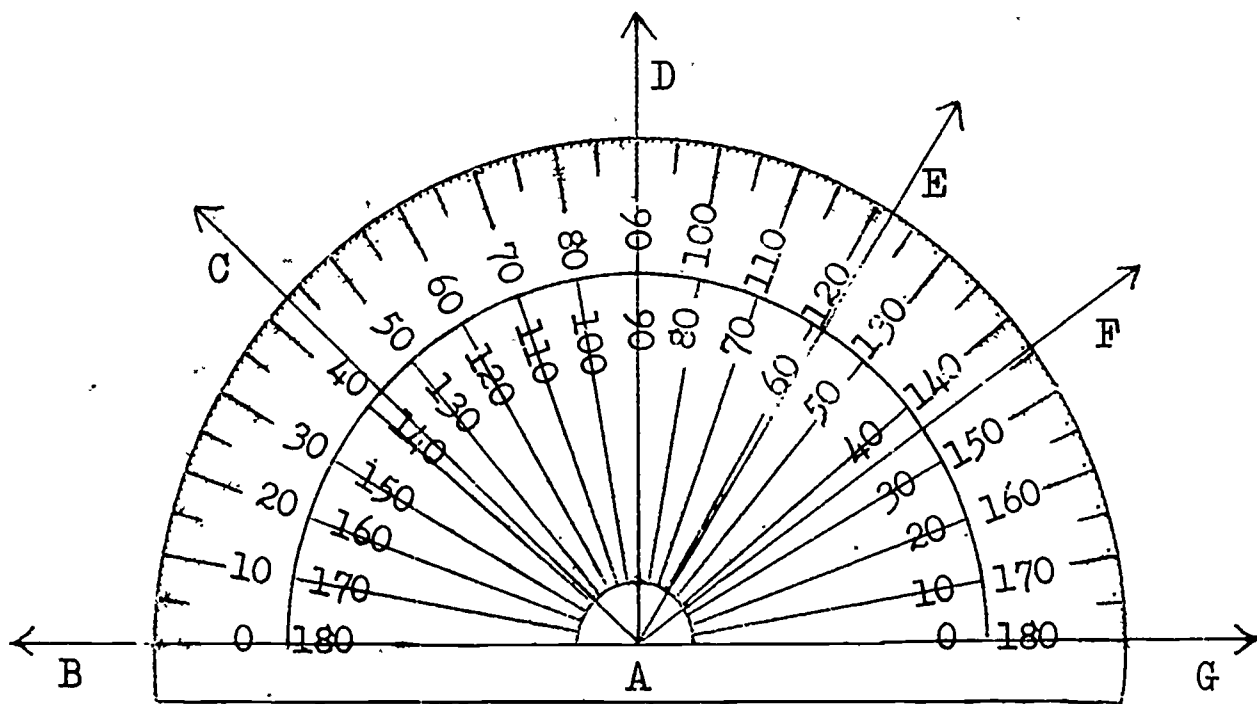

(4)

A protractor is usually divided into degrees. A degree is a unit of angle measure. There are 180 degrees in the straight angle BAG in figure (4). Hence, one degree is $(1 \div 180)$ of a straight angle.

Notice in figure (4) that the numerals on the outer scale begin with 0 on ray AB, then increase through 10, 20, 30, ..., to 180. Each of these numerals represents the number of degrees of rotation from \overrightarrow{AB} . For example, the number of degrees of rotation from \overrightarrow{AB} to \overrightarrow{AC} is 43.

However, the numerals on the inner scale in figure (4) begin with 0 on ray AG, then increase through 10, 20, 30, ..., to 180. Each of these numerals represents the number of degrees of rotation from \overrightarrow{AG} . For example, the number of degrees of rotation from \overrightarrow{AG} to \overrightarrow{AE} is 58.

What is the measure of $\angle GAF$ in figure (4)? We write: $m \angle GAF = 36$. We say: "The measure of $\angle GAF$ is 36, where the unit of measure is one degree". We also say: "The angle GAF is 36 degrees". We may write "36 degrees" as "36°". The "°" above 36 is a symbol for "degree".

When we write " $m \angle GAF$ ", we are thinking of a number. When we write " $\angle GAF$ ", we are thinking of a set of points.

For any angle XYZ,

- (1) $m \angle XYZ$ is a number.
- (2) $\angle XYZ$ is a set of points.
- (3) One degree is a unit of angle measure.

Now what is the measure of $\angle BAF$ in figure (4)? The measure of $\angle BAF$ is the amount of rotation from \overrightarrow{AB} to \overrightarrow{AF} . Hence, we shall read the numeral on the outer scale.

We write: $m \angle BAF = 144$.

We say: "The measure of $\angle BAF$ is 144, where the unit of measure is one degree". We also say: " $\angle BAF$ contains 144 degrees".

From figure (4), we may read the following measures of angles:

$$m \angle BAC = 43$$

$$m \angle GAC = 137$$

$$m \angle BAD = 90$$

$$m \angle GAD = 90$$

$$m \angle BAE = 122$$

$$m \angle GAE = 58$$

We are now ready to compare the measures of $\angle BCD$ and $\angle EFG$ in figure (3). By measuring the two angles accurately with your protractor, and by measuring to the nearest degree, you will find that $m \angle BCD = 40$, and $m \angle EFG = 43$. Since $40 < 43$, then $m \widehat{BCD} < m \widehat{EFG}$.

Notice that for any two angles CDE and FGH , exactly one of the following statements is true:

$$(1) \quad m \widehat{CDE} < m \widehat{FGH}$$

$$(2) \quad m \widehat{CDE} = m \widehat{FGH}$$

$$(3) \quad m \widehat{CDE} > m \widehat{FGH}$$

For any two angles $\angle XYZ$ and $\angle KLM$,
exactly one of the following is true:

$$(1) \quad m \widehat{XYZ} < m \widehat{KLM}$$

$$(2) \quad m \widehat{XYZ} = m \widehat{KLM}$$

$$(3) \quad m \widehat{XYZ} > m \widehat{KLM}$$

Look at this picture of $\angle ABC$:

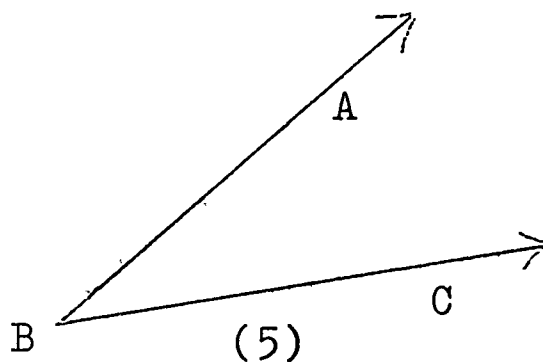

Let us agree that the amount of rotation from \overrightarrow{BC} to \overrightarrow{BA} is the same as the amount of rotation from \overrightarrow{BA} to \overrightarrow{BC} in figure (5). Hence, associated with angle ABC is one number: $m \angle ABC$.

Here are pictures of angles with a protractor placed in a correct position to measure them:

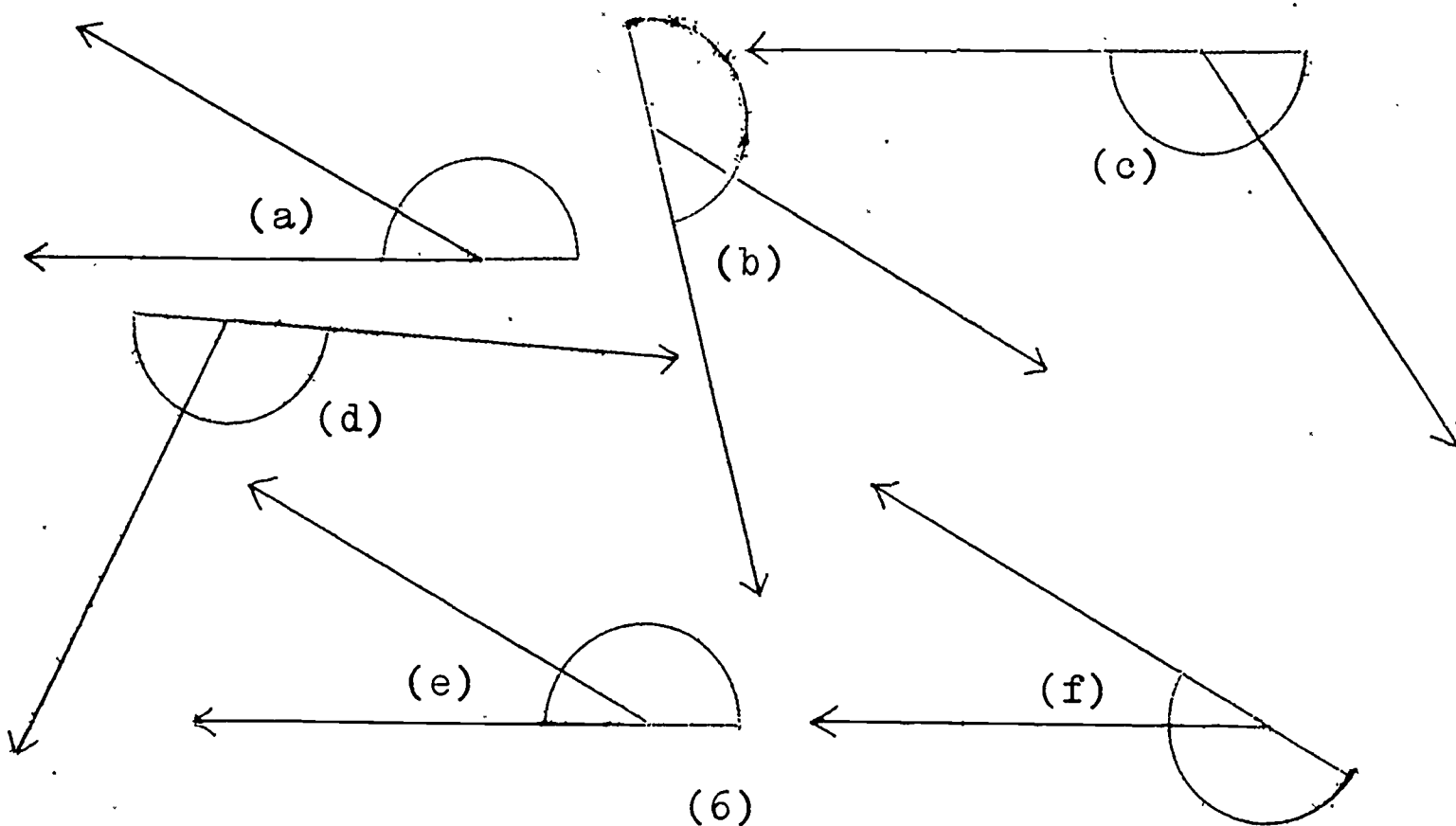

Can the protractor in each picture in figure (6) be placed in another correct position to measure each angle ?

Exercises 1-8

1. Measure each of the following angles to the nearest degree, and record your measures in your notebook.

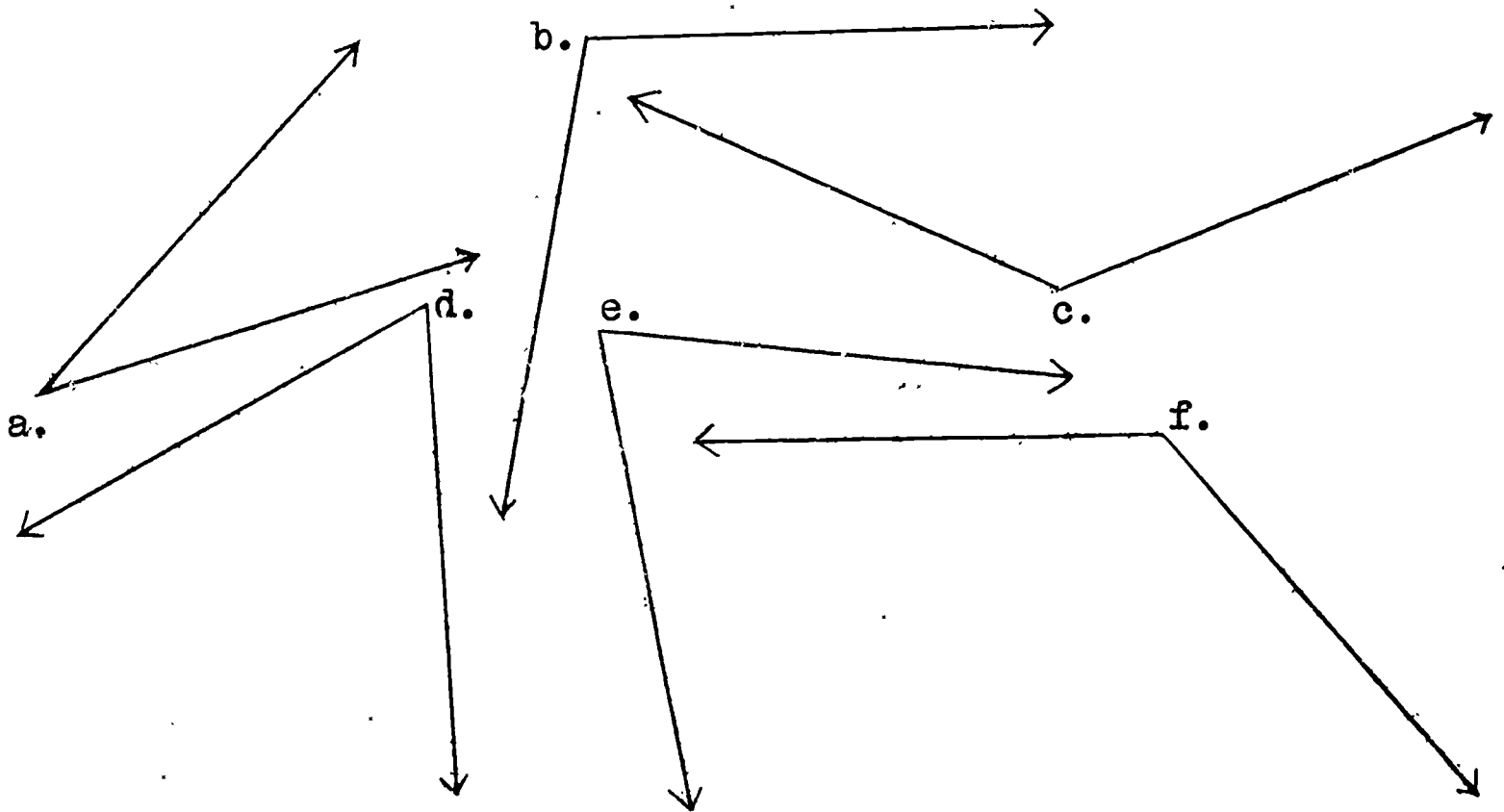

2. In figure (6), measure each angle two ways by placing the protractor in two different correct positions. Record both measures for each angle in your notebook.

3. Given the following figure:

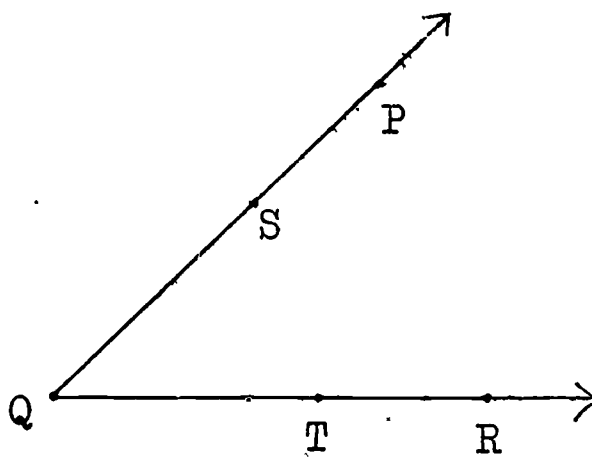

- $m \angle PQR = ?$; $m \angle RQP = ?$
- Is $m \angle PQR = m \angle RQP$?
- Is $\angle PQR = \angle RQP$?
- Is $m \angle PQT = m \angle SQR$?
- Is $\angle RQS = \angle PQT$?

4. Given the following figure:

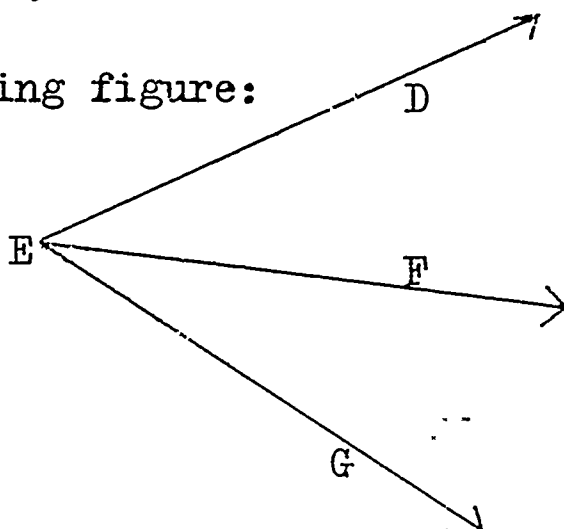

- $m \angle DEG = ?$
- $m \angle DEF = ?$
- $m \angle FEG = ?$
- Is $m \widehat{DEF} < m \widehat{DEG}$? Why ?
- Is $m \widehat{FEG} > m \widehat{DEF}$? Why ?
- Is $m \widehat{DEG} > m \widehat{FEG}$? Why ?
- Is $(m \widehat{DEF}) + (m \widehat{FEG}) = m \widehat{DEG}$? Why ?

5. Given the following figure:

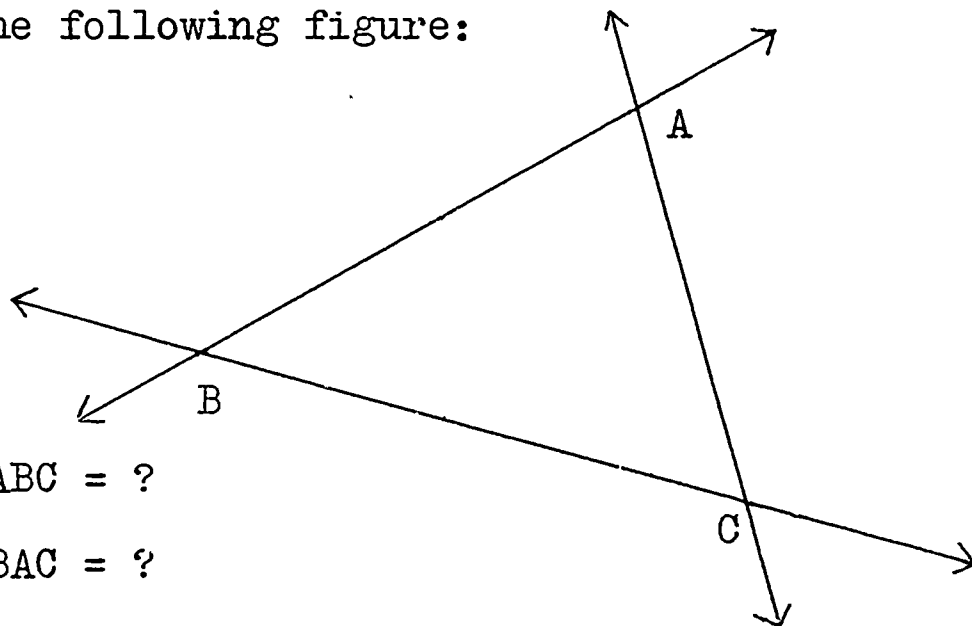

- $m \angle ABC = ?$
- $m \angle BAC = ?$
- $m \angle ACB = ?$
- Add the three measures in parts (a), (b), and (c) above. What is the sum of these measures ?

6. Given the following figure:

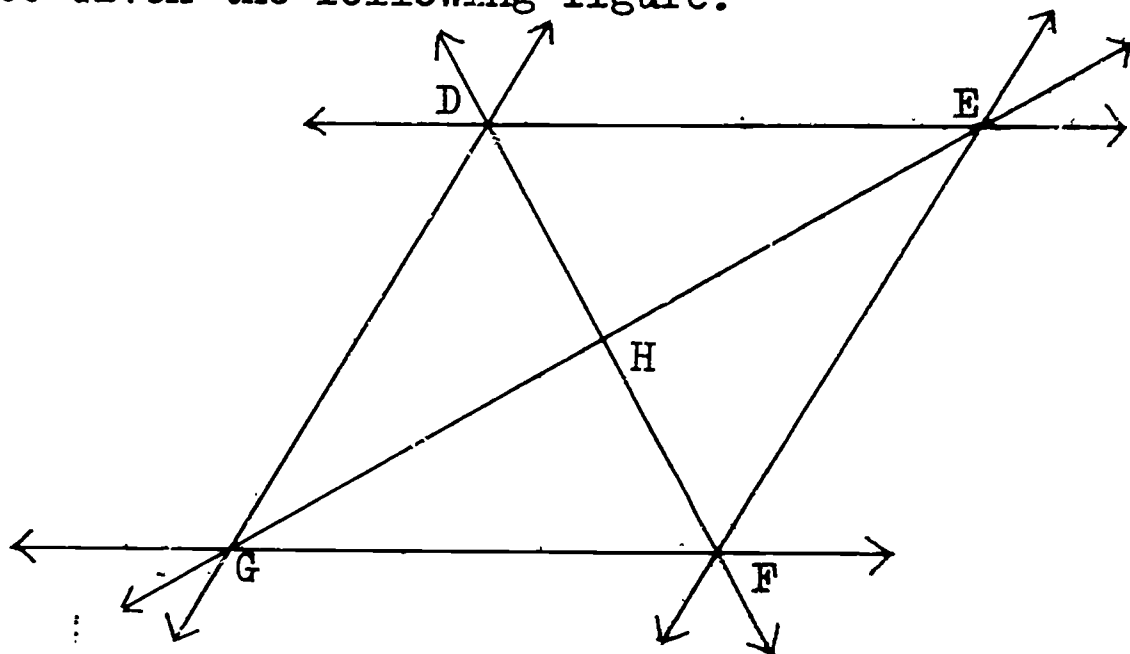

- $m \angle DEF = ?$; $m \angle DGF = ?$; What do you notice about these two measures ?
- $m \angle GDE = ?$; $m \angle GFE = ?$; What do you notice about these two measures ?
- $m \angle DEH = ?$; $m \angle FGH = ?$; What do you notice about these two measures ?
- $m \angle FED = ?$; $m \angle GFE = ?$; What is the sum of these two measures ?
- $m \angle GHD = ?$; $m \angle GHF = ?$; What do you notice about these two measures ? ; What is the sum of these two measures ?

1-9 Types of Angles

Measure the angle ABC in this picture:

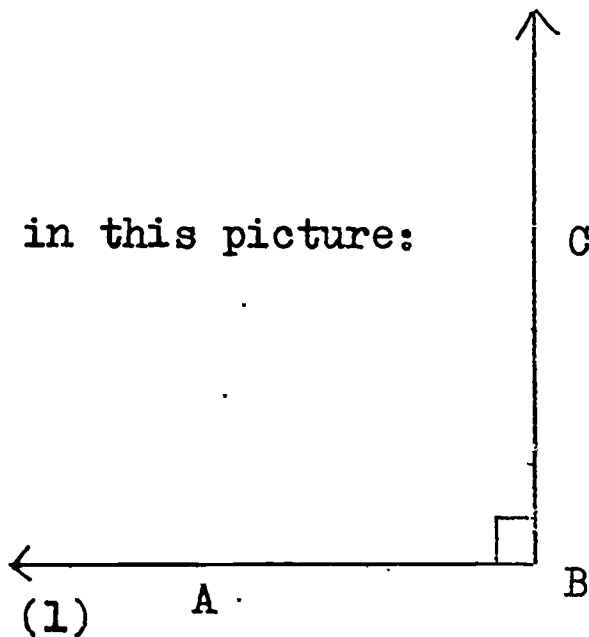

If you measure accurately, you will find that $m \widehat{ABC} = 90$.

An angle whose measure is 90 is given a special name: a right angle. Thus, $\angle ABC$ in figure (1) is a right angle. Notice the symbol " \square " at the vertex B. This symbol is used only when we refer to a right angle. Here are other pictures of right angles:

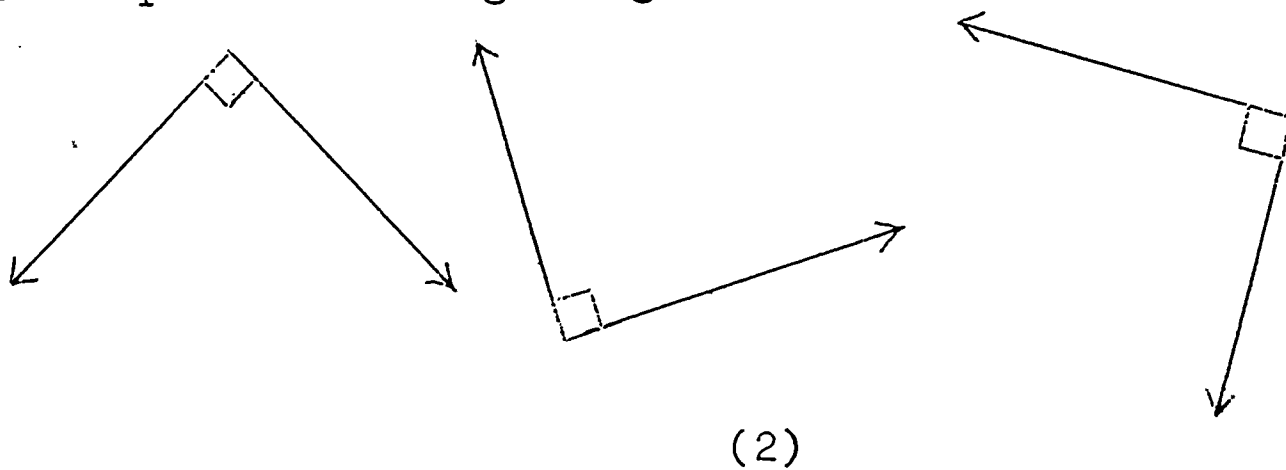

Now measure the angle BCD in this picture:

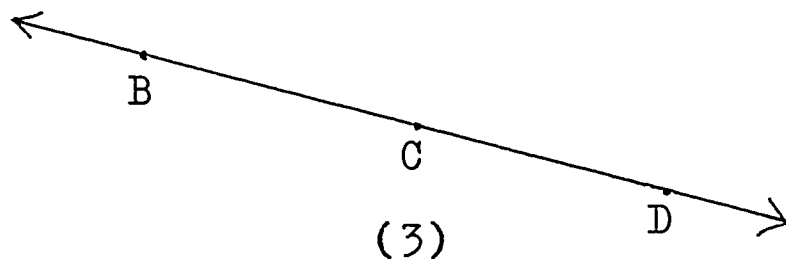

If you measure accurately, you will find that $m \angle BCD = 180$. We have already given a name to an angle such as angle BCD in Section 1-7. We called $\angle BCD$ a straight angle. Hence, the measure of a straight angle is 180.

Look at this picture of angle DEF:

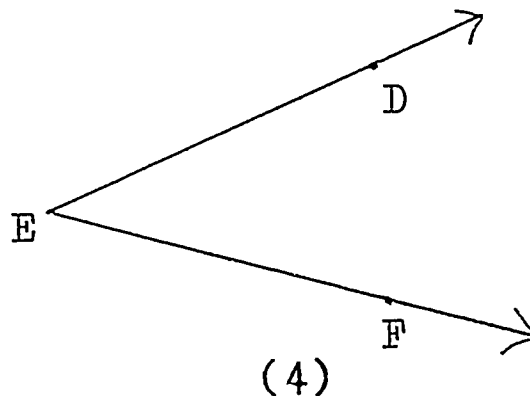

We have agreed that the measure of $\angle DEF$ is the amount of rotation from \overrightarrow{ED} to \overrightarrow{EF} , or from \overrightarrow{EF} to \overrightarrow{ED} . Associated with $\angle DEF$ is one number: $m \angle DEF$. That number is between

0 and 180 inclusive. That is,

$$0 \leq m \widehat{DEF} \leq 180 .$$

However, we occasionally wish to speak of an angle whose measure is between 180 and 360. For example, the measure of the angle whose rotation is three-fourths of a complete turn is 270. Let us agree to mark the picture of that angle as follows:

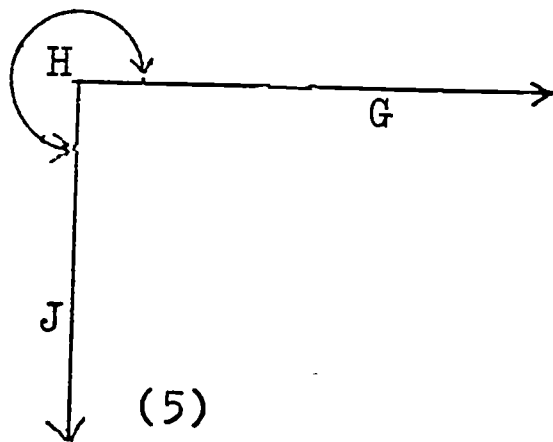

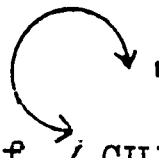
The symbol "" in figure (5) tells us that the amount of rotation of $\angle GHJ$ is between 180 and 360.

In this book, when we refer to the picture of an angle which has no symbol "" marked, we shall always mean that angle whose measure is less than or equal to 180.

Now look at these pictures of angles:

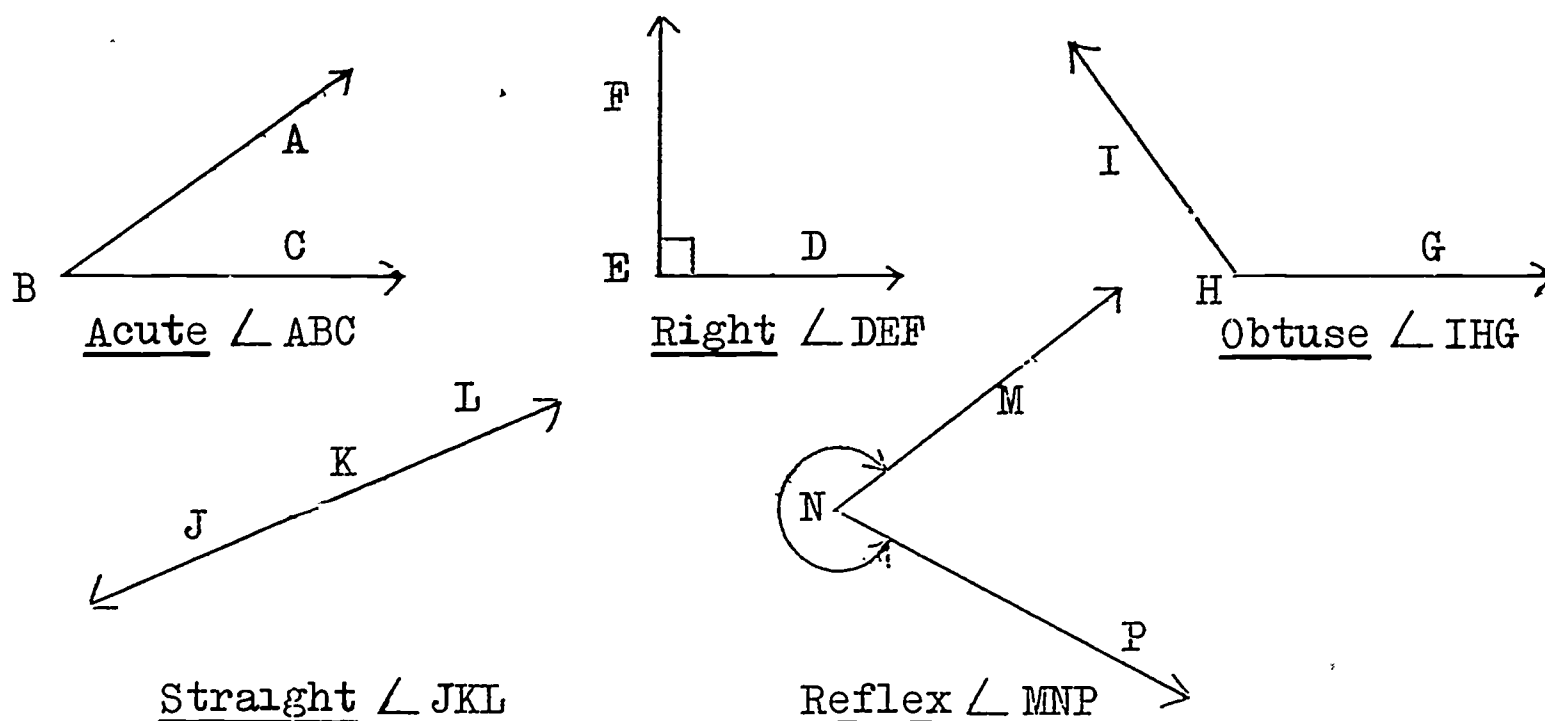

(6)

Angle ABC in figure (6) is called an acute angle. An angle is called acute if its measure is less than 90. We may write:

$$0 < m \widehat{ABC} < 90$$

Notice that the amount of rotation in an acute angle is less than one-quarter of a complete rotation.

You have already learned that $\angle FED$ in figure (6) is called a right angle. An angle is called right if its measure is 90. We may write:

$$m \widehat{FED} = 90$$

Notice that the amount of rotation in a right angle is exactly one-quarter of a complete rotation.

Angle IHG in figure (6) is called an obtuse angle. An angle is called obtuse if its measure is between 90 and 180. We may write:

$$90 < m \widehat{IHG} < 180$$

Notice that the amount of rotation in an obtuse angle is between one-fourth and one-half of a complete rotation.

You have learned that $\angle JKL$ in figure (6) is called a straight angle. An angle is called a straight angle if its measure is 180. We may write:

$$m \widehat{JKL} = 180$$

Notice that the amount of rotation in a straight angle is exactly one-half of a complete rotation.

$rm \widehat{MNP}$ is called the reflex measure of angle MNP. The reflex measure of an angle is a number between 180 and 360. We call an angle whose reflex measure is between 180 and 360 a reflex angle. Thus, $\angle MNP$ in figure (6) is called a reflex angle. We may write:

$$180 < rm \widehat{MNP} < 360$$

Notice that we write "rm" for the reflex measure of an angle.

Also notice that the amount of rotation in a reflex angle is between one-half and one complete rotation.

Remember that we must make a special symbol "  " if we wish to refer to a reflex angle in a figure.

By looking at an angle, you can easily see if it is acute or obtuse. This should help you to read your protractor correctly. If the angle is acute, you should read the numeral which is less than 90. If the angle is obtuse, you should read the numeral which is greater than 90.

How would you measure with your protractor a reflex angle? Can you measure the corresponding angle whose measure is less than 180, and then subtract that measure of the corresponding angle from 360?

For example, measure the following reflex angle:

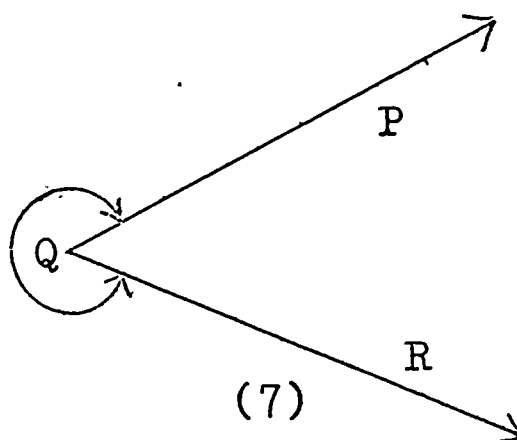

The measure of the corresponding acute angle PQR in figure (7) is:

$$m \widehat{PQR} = 48$$

Hence, the reflex measure of angle PQR in figure (7) is:

$$\begin{aligned} \text{rm } \widehat{PQR} &= 360 - 48 \\ &= 312 \end{aligned}$$

An angle XYZ is:

- (1) an acute angle if $0 < m \widehat{XYZ} < 90$
- (2) a right angle if $m \widehat{XYZ} = 90$
- (3) an obtuse angle if $90 < m \widehat{XYZ} < 180$
- (4) a straight angle if $m \widehat{XYZ} = 180$
- (5) a reflex angle if $180 < \text{rm } \widehat{XYZ} < 360$

Exercises 1-9

1. a. Measure each of the following angles, and record these measures in your notebook.
- b. State whether each angle is an acute, right, obtuse, straight, or reflex angle.

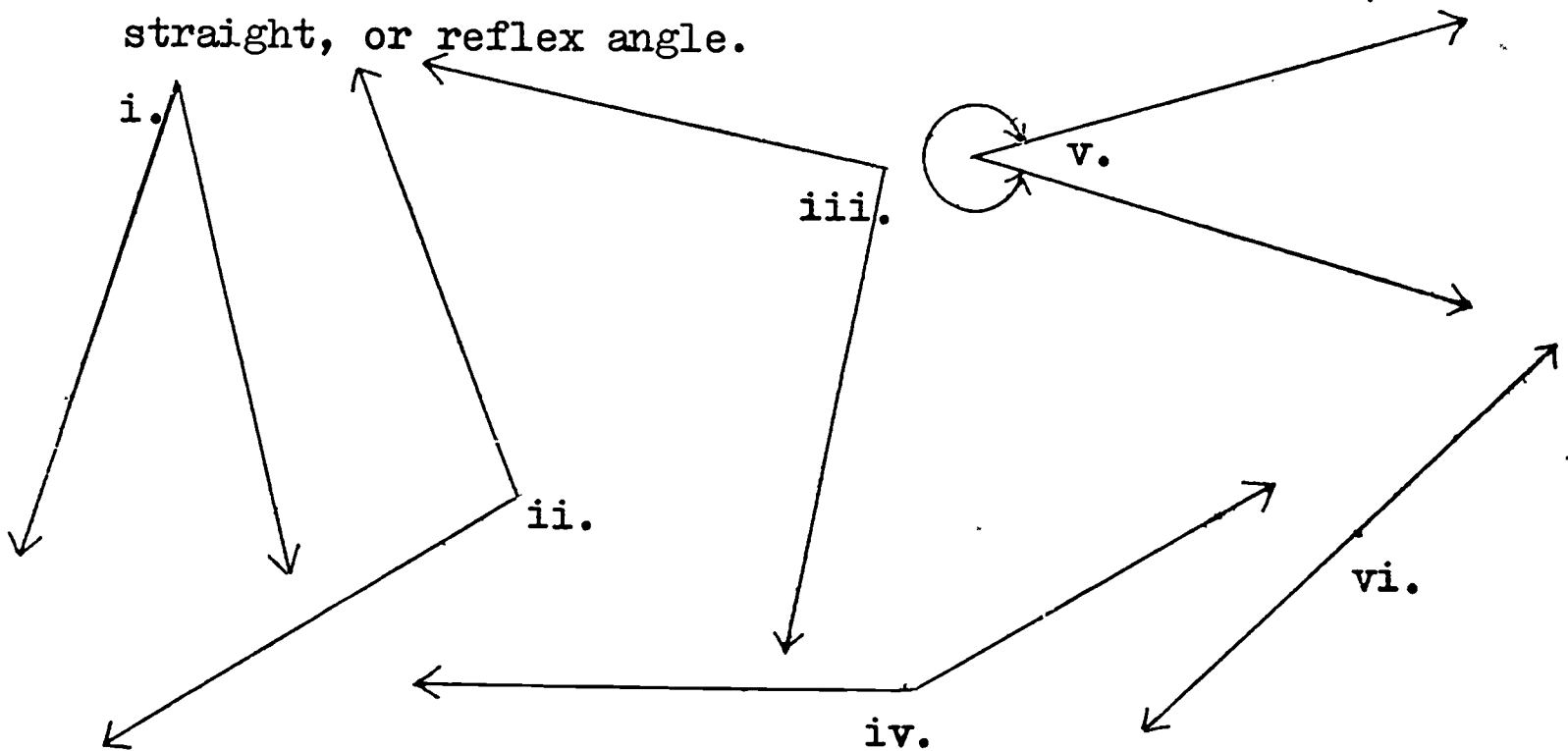

2. Given the following figure:

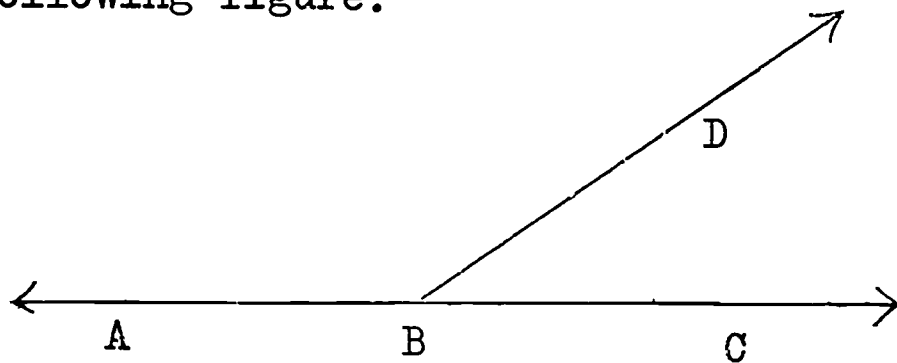

- a. $m \angle DBC = ?$; $\angle DBC$ is called an _____ angle.
- b. $m \angle ABD = ?$; $\angle ABD$ is called an _____ angle.
- c. $m \angle ABC = ?$; $\angle ABC$ is called a _____ angle.
- d. $(m \widehat{ABD}) + (m \widehat{DBC}) = ?$

3. Draw two different pictures of each of the following:
- an acute angle.
 - a right angle.
 - an obtuse angle.
 - a straight angle.
 - a reflex angle.

4. Given the following figure:

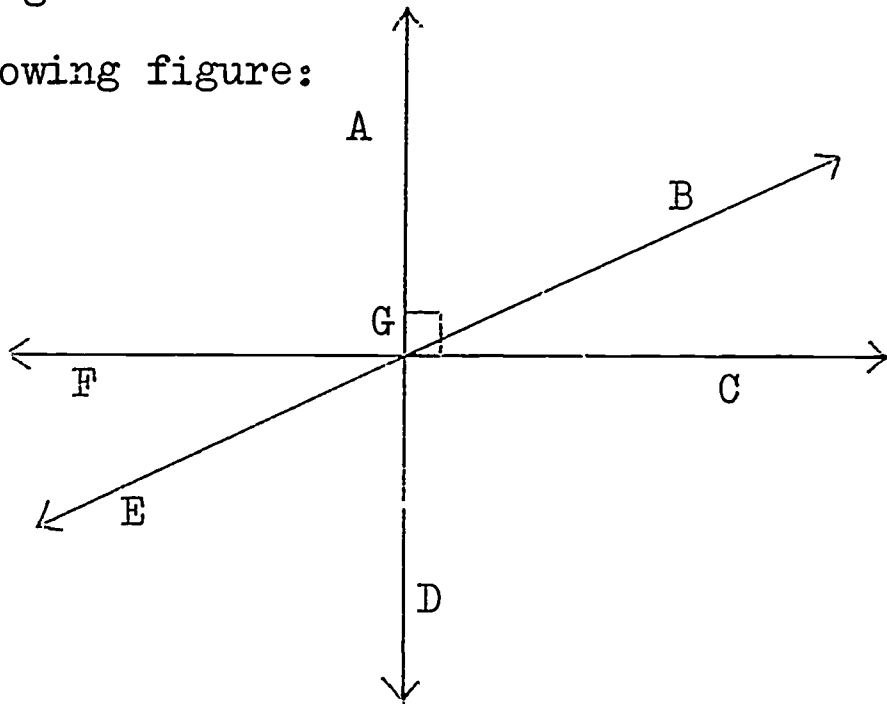

- Write one name for each acute angle in the figure.
- Measure each of the acute angles in part (a) above, and record these measures in your notebook.
- What do you notice about $m \angle AGB$ and $m \angle EGD$?
- Write one name for each right angle in the figure.
- What do you notice about $m \widehat{AGC}$, $m \widehat{AGF}$, $m \widehat{FGD}$, and $m \widehat{DGC}$?
- Write one name for each obtuse angle in the figure.
- Measure each of the obtuse angles in part (f) above, and record these measures in your notebook.
- What do you notice about $m \angle AGE$ and $m \angle BGD$?
- Write one name for each straight angle in the figure.

5. Given the following figure:

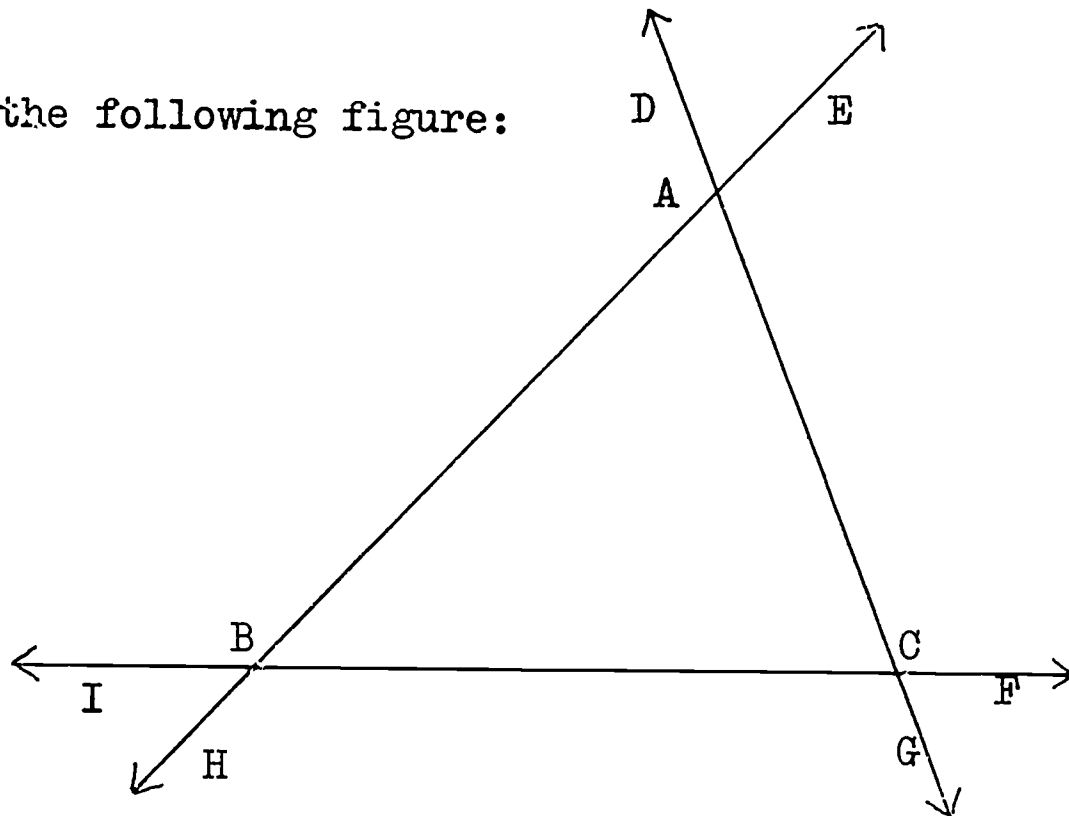

- Write one name for each acute angle in the figure.
- Measure each of the acute angles in part (a) above, and record these measures in your notebook.
- Is $m \angle BAC = m \angle DAE$? ; Is $m \angle IBH = m \angle ABC$?
Is $m \angle GCF = m \angle BCA$?
- $(m \widehat{BAC}) + (m \widehat{ACB}) + (m \widehat{ABC}) = ?$
- Write one name for each obtuse angle in the figure.
- Measure each obtuse angle in part (e) above, and record these measures in your notebook.
- Is $m \widehat{ACF} = (m \widehat{BAC}) + (m \widehat{ABC})$?
- What do you notice about $m \widehat{EAC}$ and $(m \widehat{ABC}) + (m \widehat{BCA})$?
- What do you notice about $m \widehat{IBA}$ and $(m \widehat{BAC}) + (m \widehat{ACB})$?

6. Given the following figure:

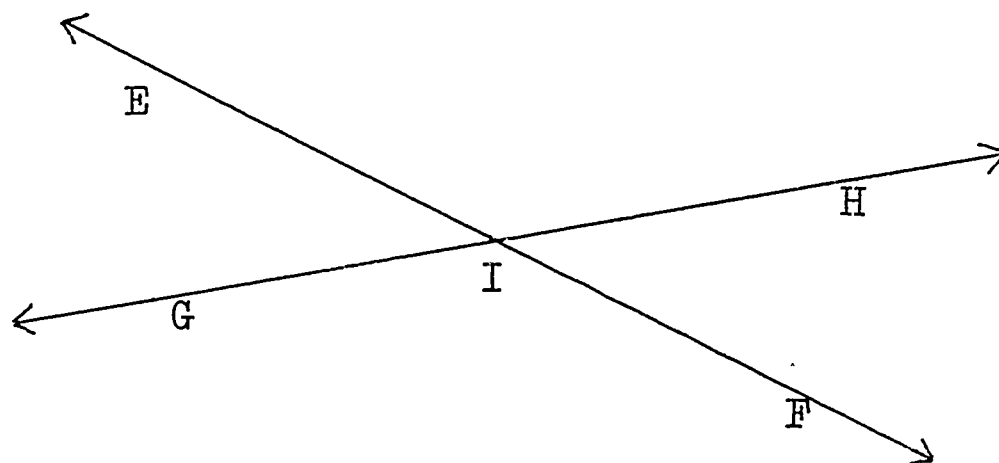

- $m \angle EIG = ?$; $\angle EIG$ is called an _____ angle.
 - $m \angle HIF = ?$; $\angle HIF$ is called an _____ angle.
 - What do you notice about the measures of $\angle EIG$ and $\angle HIF$?
 - $m \widehat{EIH} = ?$; \widehat{EIH} is called a _____ angle.
 - $m \widehat{GIF} = ?$; \widehat{GIF} is called a _____ angle.
 - What do you notice about the reflex measures of $\angle EIH$ and $\angle GIF$?
7. Copy and complete the following sentences in your notebook.
- A ray is the union of a _____ and its _____.
 - An angle is the _____ of two _____ with a common _____.
 - The measure of a right angle is _____.
 - An acute angle has its measure _____ than 90 but _____ to 0.
 - For any ray AB , $m \angle BAB =$ _____.
 - An obtuse angle has its measure _____ than _____ but less than _____.
 - The measure of a reflex angle is between _____ and _____.
 - A ruler is to a line segment as a _____ is to an angle.
 - A rotation of five-eighths of a complete turn would measure _____ degrees.

8. A compass is used to indicate direction. Here is a picture of a face of a compass:

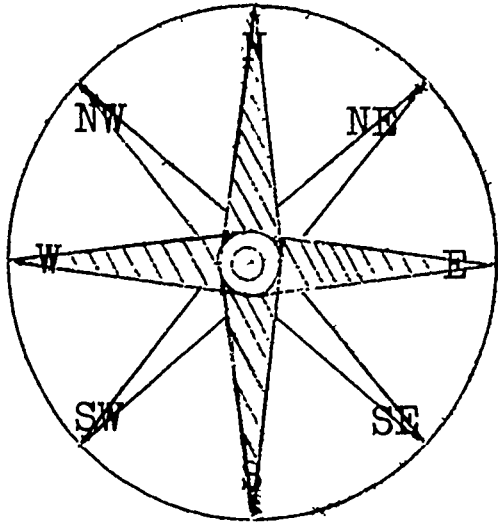

In a clockwise direction, "NE from N" has a degree measure of 45. Find the degree measure of each of the following, where the rotation is clockwise:

- | | |
|--------------|--------------|
| a. E from NE | f. NE from S |
| b. NW from S | g. W from N |
| c. SE from N | h. E from N |
| d. SW from N | i. NW from S |
| e. SE from S | j. N from S |
9. Direction or bearing is often given as the number of degrees east or west from the north or from the south. For example, N 56° E means: "From the north, 56 degrees to the east", and S 23° W means: "From the south, 23 degrees to the west". Draw an angle which represents each of the following bearings:
- | | |
|-------------|-------------|
| a. N 48° E | g. N 154° E |
| b. N 85° E | h. S 72° W |
| c. N 123° W | i. S 156° E |
| d. S 17° E | j. N 59° W |
| e. S 115° W | k. S 158° W |
| f. N 75° W | l. S 119° E |

1-10 Perpendicular and Parallel Lines

Look at the following picture:

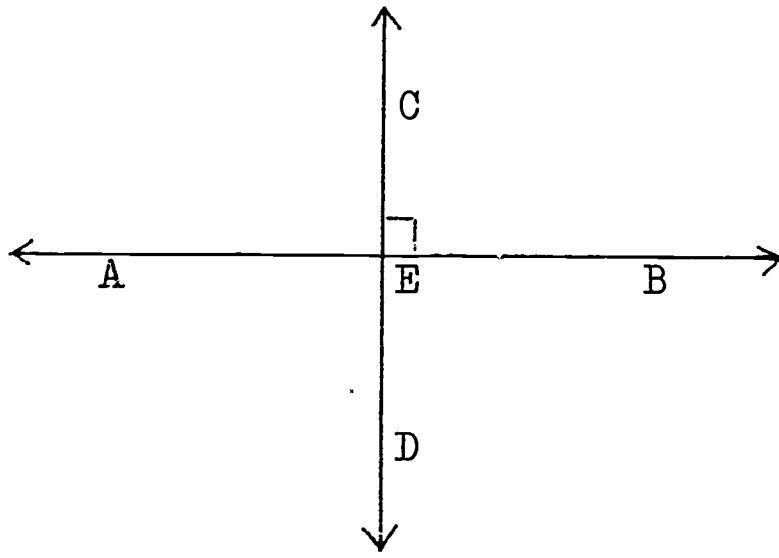

In figure (1), \overline{AB} and \overline{CD} intersect at point E to form four angles: $\angle CEB$, $\angle CEA$, $\angle BED$, and $\angle DEA$. Notice the symbol " \square " at $\angle CEB$. We know that this symbol means that $\angle CEB$ is a right angle. $\angle AEB$ is a straight angle. What is the measure of $\angle CEA$? Why?

We say that the lines AB and CD are perpendicular to each other at the point E. The lines AB and CD are perpendicular to each other because they intersect at a right angle. We write:

$$\overleftrightarrow{AB} \perp \overleftrightarrow{CD} .$$

The symbol " \perp " means "is perpendicular to" .

Since $\overline{AB} \subset \overleftrightarrow{AB}$, and $\overline{CD} \subset \overleftrightarrow{CD}$, then we can also say that $\overline{AB} \perp \overline{CD}$. Do you agree?

Now look at this picture:

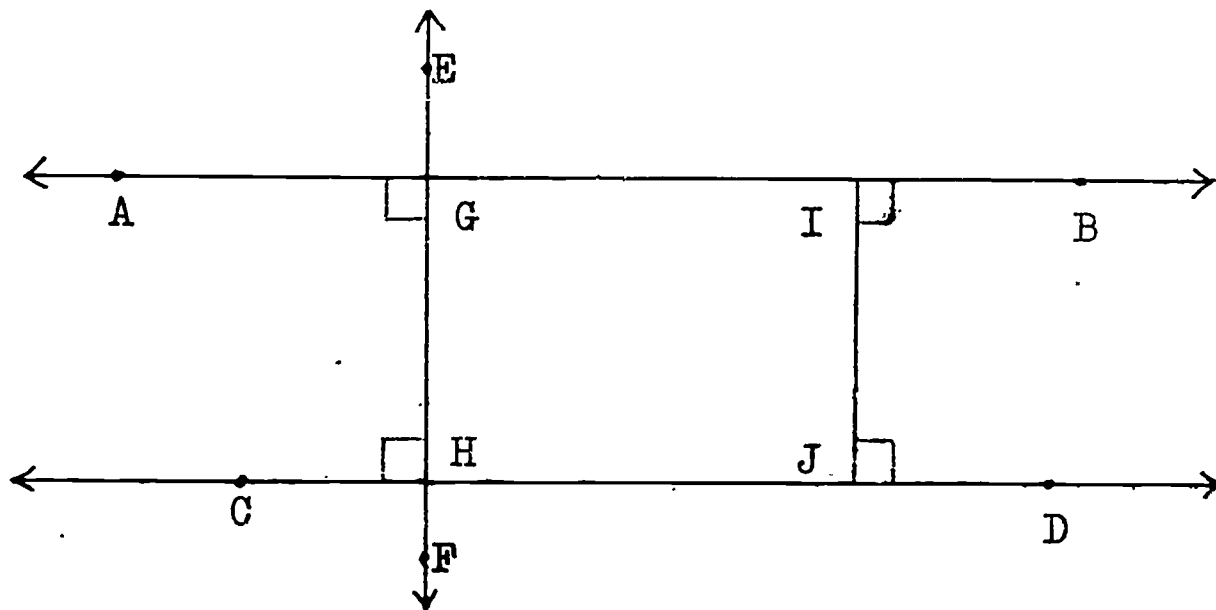

In figure (2), \overleftrightarrow{AB} is drawn perpendicular to \overleftrightarrow{EF} , and \overleftrightarrow{CD} is drawn perpendicular to \overleftrightarrow{EF} .

If you measure the length of \overline{GH} , using one inch as your unit of measure, you will find that $m\overline{GH} = 1.2$. Also, if you measure \overline{IJ} , you will find that $m\overline{IJ} = 1.2$.

Hence, $m\overline{GH} = m\overline{IJ}$. If we draw a perpendicular from point C to \overleftrightarrow{AB} , meeting \overleftrightarrow{AB} at K, and find its measure, do you think that $m\overline{CK} = 1.2$? Do you think that if any line segment XY is drawn perpendicular to \overleftrightarrow{AB} and \overleftrightarrow{CD} , then $m\overline{XY} = 1.2$? Do you think that the lines \overleftrightarrow{AB} and \overleftrightarrow{CD} will ever intersect?

Two lines which never intersect are called parallel lines. Thus \overleftrightarrow{AB} and \overleftrightarrow{CD} are parallel lines. We write:

$$\overleftrightarrow{AB} \parallel \overleftrightarrow{CD} .$$

The symbol " \parallel " means "is parallel to".

We know that a line is a set of points. The two parallel lines AB and CD in figure (2) do not intersect in any point. Hence, we can write:

$$\overleftrightarrow{AB} \cap \overleftrightarrow{CD} = \emptyset$$

Since $\overline{AB} \subset \overleftrightarrow{AB}$, and $\overline{CD} \subset \overleftrightarrow{CD}$, then we can also say that $\overline{AB} \parallel \overline{CD}$. Do you agree?

Exercises 1-10

1. Follow the directions and draw the figure in your notebook.
 - a. Draw a line PQ .
 - b. Let R be a point on \overleftrightarrow{PQ} .
 - c. Draw a line RS so that $m \angle QRS = 90^\circ$.
 - d. What can you say about \overleftrightarrow{RS} and \overleftrightarrow{PQ} ?
 - e. Draw a line ST so that $m \angle TSR = 90^\circ$.
 - f. What is true about \overleftrightarrow{ST} and \overleftrightarrow{SR} ?
 - g. With your protractor, draw $\overline{TV} \perp \overleftrightarrow{RQ}$. V is on \overleftrightarrow{PQ} .
 - h. $m \overline{SR} = ?$; $m \overline{TV} = ?$; What do you notice about these two measures?
 - i. Do you think that any line segment with endpoints on \overleftrightarrow{ST} and \overleftrightarrow{PQ} perpendicular to \overleftrightarrow{PQ} will have its measure equal to $m \overline{SR}$?
 - j. What conclusion can you state about \overleftrightarrow{ST} and \overleftrightarrow{PQ} ?
 - k. $\overleftrightarrow{ST} \cap \overleftrightarrow{PQ} = ?$

2. Given the following figure in which $\overleftrightarrow{AB} \parallel \overleftrightarrow{CD}$.

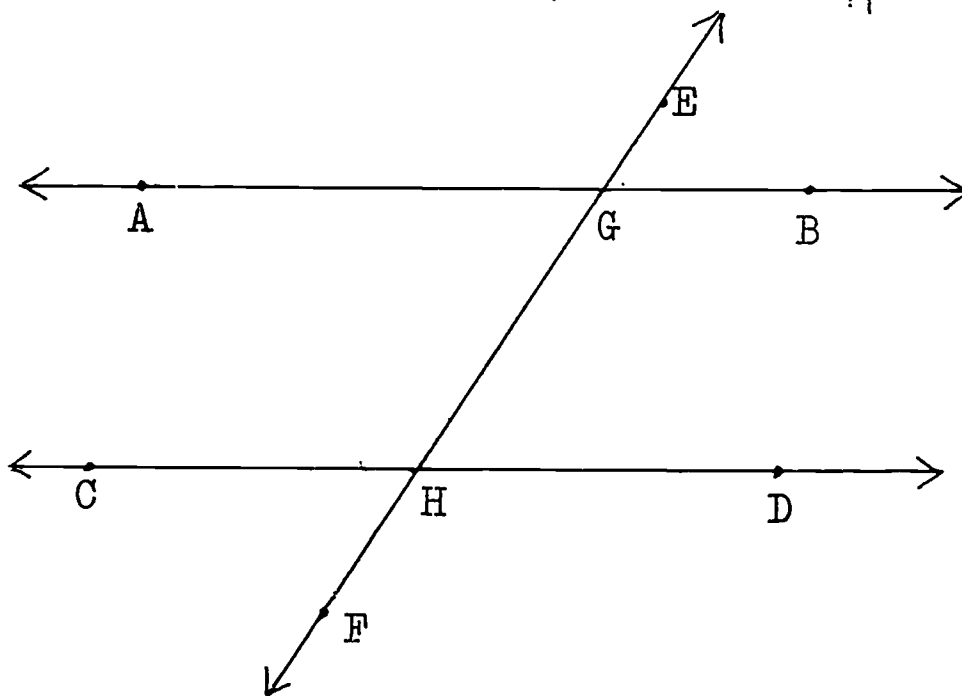

- a. $m \angle EGB = ?$; $m \angle GHD = ?$; What do you notice about these two measures ?
- b. $m \angle HGB = ?$; $m \angle GHC = ?$; What do you notice about these two measures ?
- c. $m \angle AGH = ?$; $m \angle CHG = ?$; $(m \widehat{AGH}) + (m \widehat{CHG}) = ?$;
What do you notice about the sum of these two measures ?
- d. $m \angle EGB = ?$; $m \angle AGE = ?$; What do you notice about the sum of these two measures ?
- e. $m \angle CHF = ?$; $m \angle BGE = ?$; What do you notice about these two measures ?

3. Given the following figure:

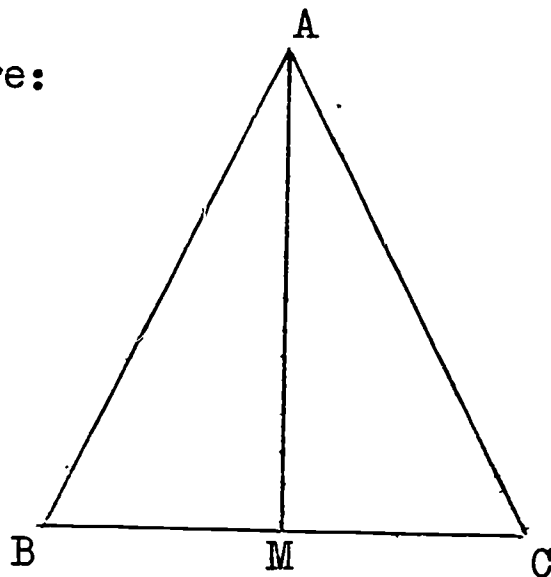

- a. $m \overline{AB} = ?$; $m \overline{AC} = ?$; What do you notice about these two measures ?
- b. $m \overline{BM} = ?$; $m \overline{MC} = ?$; What do you notice about these two measures ?
- c. $m \angle AMB = ?$; $m \angle AMC = ?$; What do you notice about these two measures ?
- d. What conclusion can you state about \overline{AM} and \overline{BC} ?

4. Given the following figure:

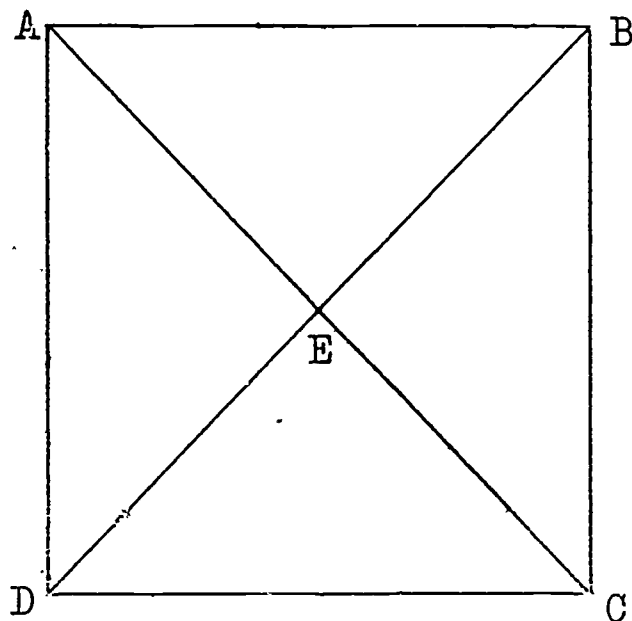

- a. $m \angle DAB = ?$; $m \angle ADC = ?$; What conclusion can you state about \overline{BA} and \overline{AD} ? ; about \overline{CD} and \overline{AD} ?
- b. $m \overline{AD} = ?$; $m \overline{BC} = ?$; What conclusion can you state about \overline{AB} and \overline{CD} ?
- c. $m \overline{AB} = ?$; $m \overline{DC} = ?$; What conclusion can you state about \overline{AD} and \overline{BC} ?
- d. $m \overline{AC} = ?$; $m \overline{DB} = ?$; What do you notice about these two measures ?
- e. $m \angle DEA = ?$; $m \angle DEC = ?$; What do you notice about these two measures ?
- f. What conclusion can you state about \overline{AC} and \overline{DB} ?

5. Given the following figure:

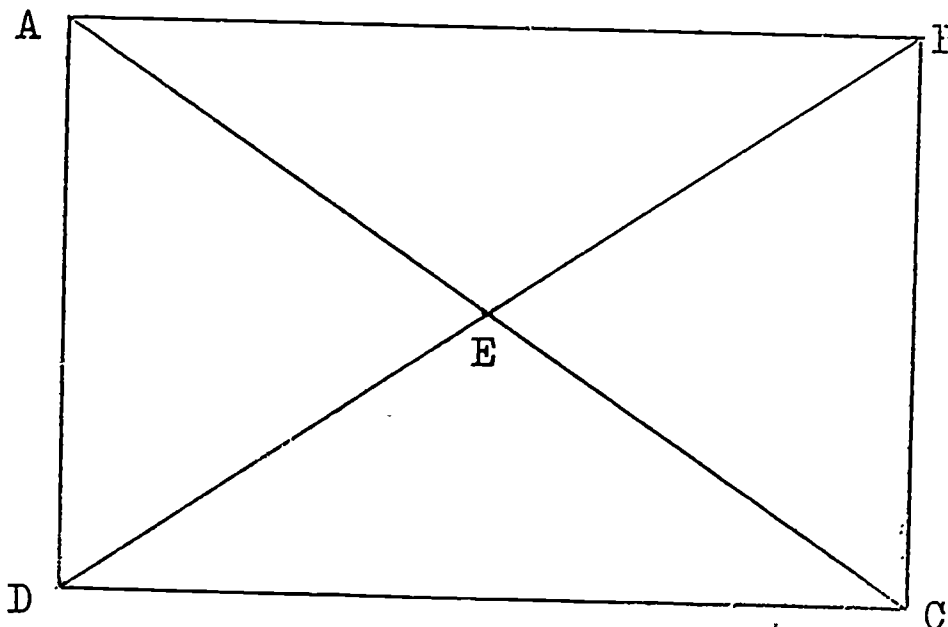

Answer parts (a) - (f) of Exercise 4 above, using this figure.

6. Given the following figure in which $\overline{PQ} \parallel \overline{SR}$ and $\overline{PS} \parallel \overline{QR}$.

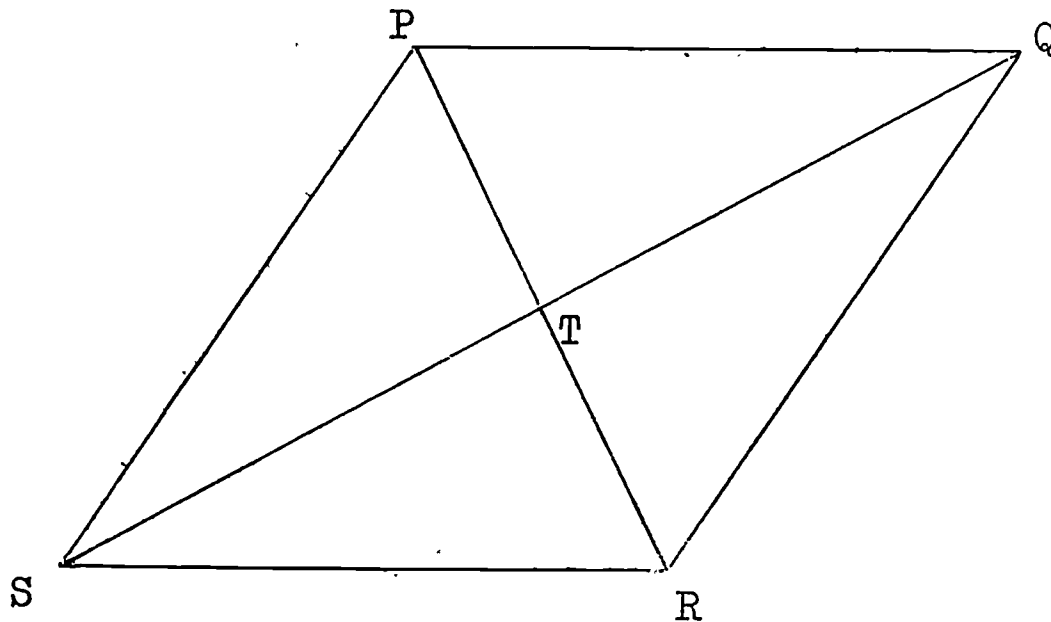

- $m \overline{PQ} = ?$; $m \overline{SR} = ?$; What do you notice about these two measures ?
- $m \overline{PS} = ?$; $m \overline{QR} = ?$; What do you notice about these two measures ?
- What do you notice about the four measures in parts (a) and (b) above ?

- d. $m \angle RPQ = ?$; $m \angle PRS = ?$; What do you notice about these two measures ?
- e. $m \angle PSR = ?$; $m \angle PQR = ?$; What do you notice about these two measures ?
- f. $m \angle SPQ = ?$; $m \angle RSP = ?$; What do you notice about the sum of these two measures ?
- g. $m \angle STP = ?$; $m \angle STR = ?$; What do you notice about these two measures ?
- h. What conclusion can you state about \overline{PR} and \overline{SQ} ?
- i. $m \overline{PT} = ?$; $m \overline{TR} = ?$; What do you notice about these two measures ?
- j. $m \overline{ST} = ?$; $m \overline{TQ} = ?$; What do you notice about these two measures ?

7. Given the following figure in which $\overline{PQ} \parallel \overline{SR}$, and $\overline{PS} \parallel \overline{QR}$.

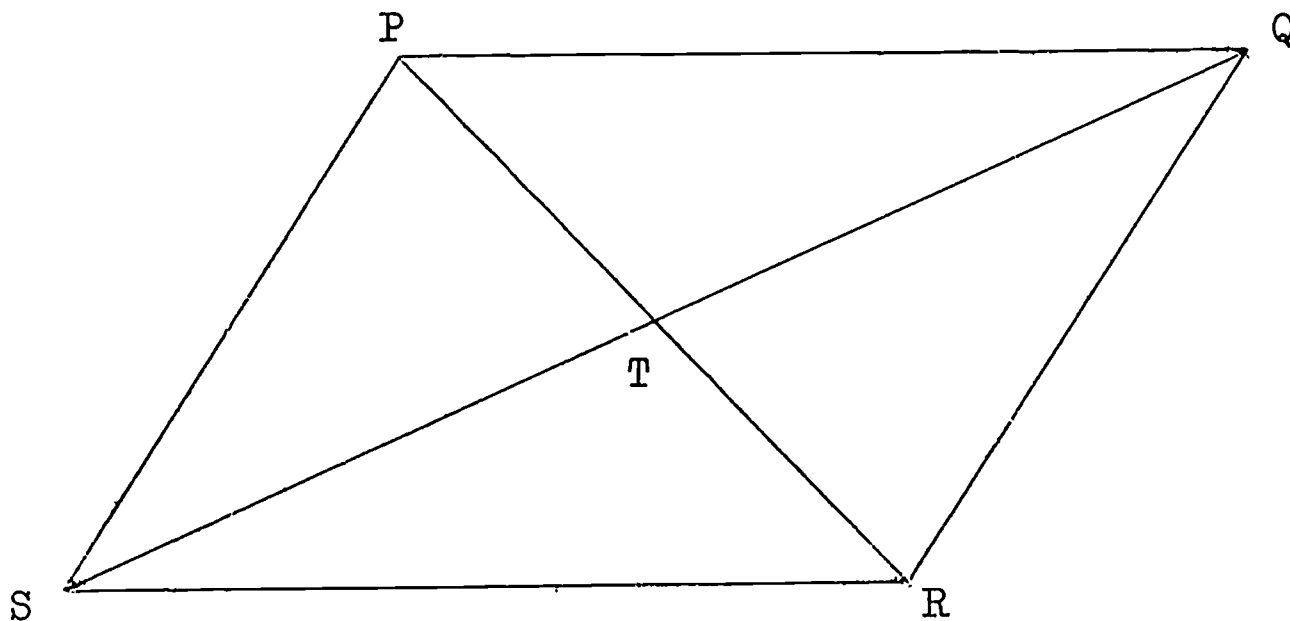

Answer parts (a) - (j) of Exercise 6 above, using this figure.

Revision Test # 1

1. Fill in the blanks to make each sentence true. Show all work in your notebook.
 - a. A point P has no _____, but it has _____.
 - b. A line AB is a set of points extending _____ in _____ directions.
 - c. A ray CB is the _____ of point C and the _____ containing point B.
 - d. In angle CAB, the point A is called the _____ point.
 - e. Through two points A and B, only _____ line AB can be drawn.
 - f. If two lines PQ and RS intersect at T so that $m \angle RTQ = 90$, then \overrightarrow{PQ} and \overrightarrow{RS} are _____ to each other.
 - g. If $m \widehat{DEF} = 47$, and $m \widehat{GHI} = 47$, then $m \widehat{DEF}$ _____ $m \widehat{GHI}$.
 - h. If $m \widehat{ABC} = 90$, then $\angle ABC$ is called a _____ angle.
 - i. If $m \widehat{KLM} = 227$, then \widehat{KLM} is called a _____ angle.
 - j. The measure of the angle which represents the rotation of SE from N in a clockwise direction is _____.
 - k. If T is a point on \overline{PQ} , then \overline{PT} _____ \overline{TQ} .
 - l. If T is a point on \overrightarrow{PQ} , then \overrightarrow{PQ} _____ \overrightarrow{PT} .
 - m. All straight angles have a measure of _____.
 - n. A unit of measure for angles is called a _____.
 - o. If $\angle ABC$ is acute, then 0 _____ $m \widehat{ABC}$ _____ 90 .

2. Find the set in W whose name is given in J by writing the correct letter in the space provided. Do your work in your notebook. Point A is between B and C on \overleftrightarrow{BC} .

J	W
.....1. Line AB	A. $\overleftrightarrow{AB} \cup \overleftrightarrow{AC}$
.....2. Ray AB	B. $\overline{AC} \cap \overline{BC}$
.....3. Line segment AB	C. $\overline{BA} \cup \overleftrightarrow{AC}$
.....4. angle BAC	D. $\overline{BA} \cap \overleftrightarrow{AC}$
.....5. Line segment AC	E. \overleftrightarrow{AB}
.....6. Ray BC	F. $\overline{BA} \cup \overline{AC}$
.....7. $\{A\}$	G. \overline{AB}
.....8. Line segment BC	H. $\overline{BA} \cap \{\text{half-line } AC\}$
.....9. \emptyset	I. $\{C\} \cup \{\text{half-line } CB\}$
.....10. Ray CB	J. $\{A\} \cup \{\text{half-line } AC\}$
	K. \overleftrightarrow{AB}

3. Given the following figure:

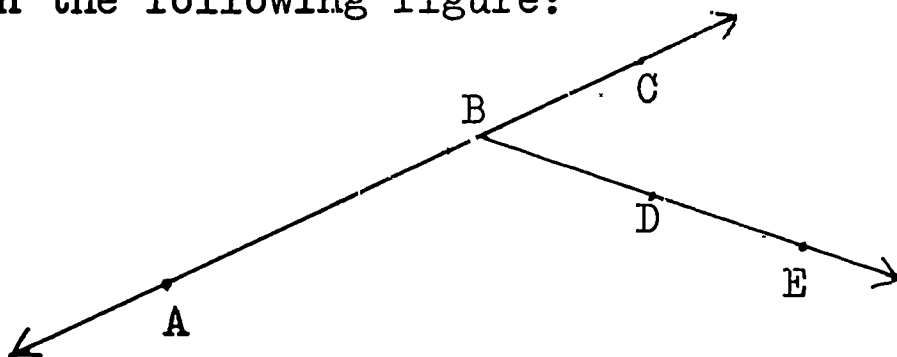

a. $\overleftrightarrow{AB} \cup \overleftrightarrow{BC} = ?$

b. $\overleftrightarrow{AB} \cap \overleftrightarrow{BC} = ?$

c. $\overleftrightarrow{AB} \cap \overline{BC} = ?$

d. $\overline{BC} \cup \overleftrightarrow{BD} = ?$

e. $\overline{BC} \cap \overleftrightarrow{BE} = ?$

f. $\overline{DE} \cap \overleftrightarrow{BC} = ?$

g. $\overline{BC} \cap \overline{AC} = ?$

h. $\overline{BA} \cap \overleftrightarrow{AB} = ?$

i. $\{B\} \cup \{\text{half-line } BE\} = ?$

j. $\overline{BA} \cup \overleftrightarrow{BD} = ?$

4. Given the following figure in which $\overline{AB} \parallel \overline{DC}$, and $\overline{AD} \parallel \overline{BC}$.

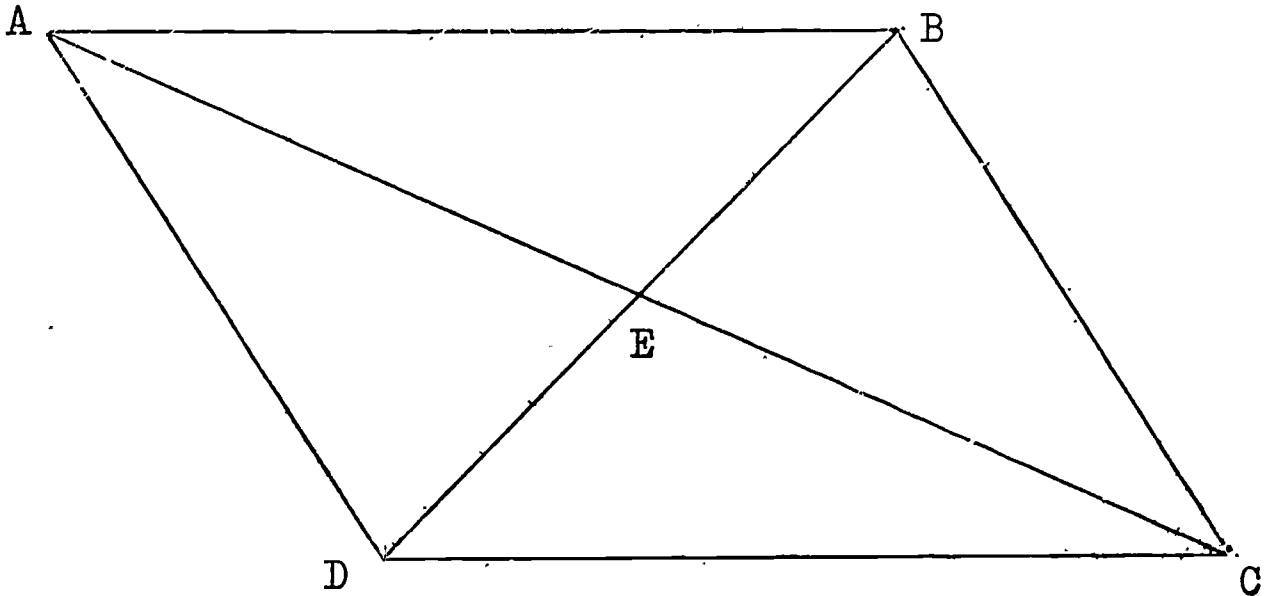

- a. $m \overline{AB} = ?$; $m \overline{DC} = ?$; What do you notice about these two measures ?
- b. $m \overline{AD} = ?$; $m \overline{BC} = ?$; What do you notice about these two measures ?
- c. $m \angle DAB = ?$; $m \angle ADC = ?$; What do you notice about the sum of these two measures ?
- d. $m \angle ABC = ?$; $m \angle BCD = ?$; What do you notice about the sum of these two measures ?
- e. $m \overline{AE} = ?$; $m \overline{EC} = ?$; What is true of these two measures ?
- f. $m \overline{DE} = ?$; $m \overline{EB} = ?$; What is true of these two measures ?

Revision Test # 2

1. Fill in the blanks to make each sentence true. Write your answer in your notebook.
- Two points B and C are different points because they occupy _____ positions.
 - The points C and D on \overline{CD} are called _____.
 - Angle CAB is the _____ of two _____ AC and AB.
 - Through one point, an _____ number of lines can be drawn.
 - If two lines PQ and RS never intersect, then \overleftrightarrow{PQ} is _____ to \overleftrightarrow{RS} .
 - If $m \overline{CD} = 3.6$, and $m \overline{EF} = 3.8$, then $m \overline{CD}$ _____ $m \overline{EF}$.
 - If \overleftrightarrow{PQ} and \overleftrightarrow{RS} are parallel, then $\overleftrightarrow{PQ} \cap \overleftrightarrow{RS} =$ _____.
 - If $m \widehat{DEF} = 172$, then \widehat{DEF} is called an _____ angle.
 - N 36° W means: "From the _____, 36 degrees to the _____."
 - If T is a point on \overleftrightarrow{PQ} , then \overleftrightarrow{PT} and \overleftrightarrow{TQ} are the _____ line.
 - If T is a point on \overleftrightarrow{PQ} , then \overleftrightarrow{PQ} _____ \overleftrightarrow{TQ} .
 - An obtuse angle has its measure between _____ and _____.
 - A unit of measure for line segment AB is one _____ or one _____.
 - If $\angle ABC$ is acute then 0 _____ $m \widehat{ABC}$ _____ 90
 - If PQ is a ray, then $m \angle QPQ =$ _____.

2. Find the set in X whose name is given in Y, then write the correct letter in the space provided. Do your work in your notebook. Points R and S are between P and Q, and R is between P and S on \overline{PQ} .

Y	X
.....1. Line segment PR	A. \overrightarrow{PR}
.....2. Line PR	E. $\overline{RS} \cup \overrightarrow{SQ}$
.....3. Ray PR	C. $\{S\} \cup \{\text{half-line } SQ\}$
.....4. Ray RS	D. $\overline{PR} \cap \overline{RS}$
.....5. Angle PRS	E. $\overline{PR} \cap \overline{SQ}$
.....6. \overrightarrow{SQ}	F. \overline{PR}
.....7. $\{R\}$	G. $\overrightarrow{SR} \cap \overrightarrow{SQ}$
.....8. \overline{SQ}	H. $\overrightarrow{PQ} \cap \overrightarrow{RQ}$
.....9. \emptyset	I. $\overline{RQ} \cap \overline{SQ}$
.....10. $\{S\}$	J. $\overrightarrow{RP} \cup \overrightarrow{RS}$
	K. \overleftrightarrow{PR}

3. Given the following figure:

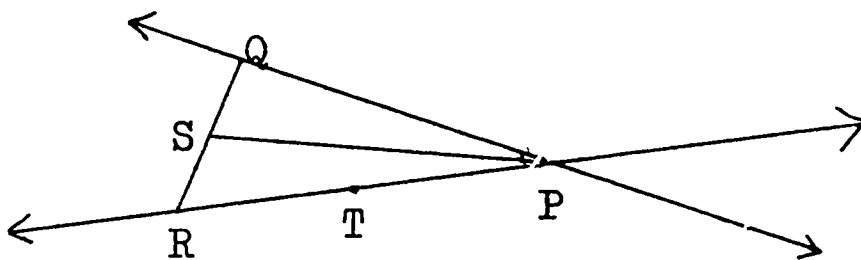

- | | |
|---|--|
| a. $\overleftrightarrow{QP} \cap \overleftrightarrow{RP} = ?$ | f. $\overline{PT} \cup \overline{TR} = ?$ |
| b. $\overleftrightarrow{RT} \cap \overleftrightarrow{RP} = ?$ | g. $\overrightarrow{QP} \cup \overrightarrow{QR} = ?$ |
| c. $\overline{RT} \cap \overline{RP} = ?$ | h. Is $\overline{RP} \cup \overline{PS} = \overline{SR}$? |
| d. $\overline{PS} \cap \overline{PT} = ?$ | i. Is $\overline{QS} \cup \overline{SR} = \overline{QR}$? |
| e. $\overline{PT} \cup \overline{TR} = ?$ | j. $\overline{QS} \cap \overline{RT} = ?$ |

4. Given the following figure in which $\overline{AB} \parallel \overline{DC}$.

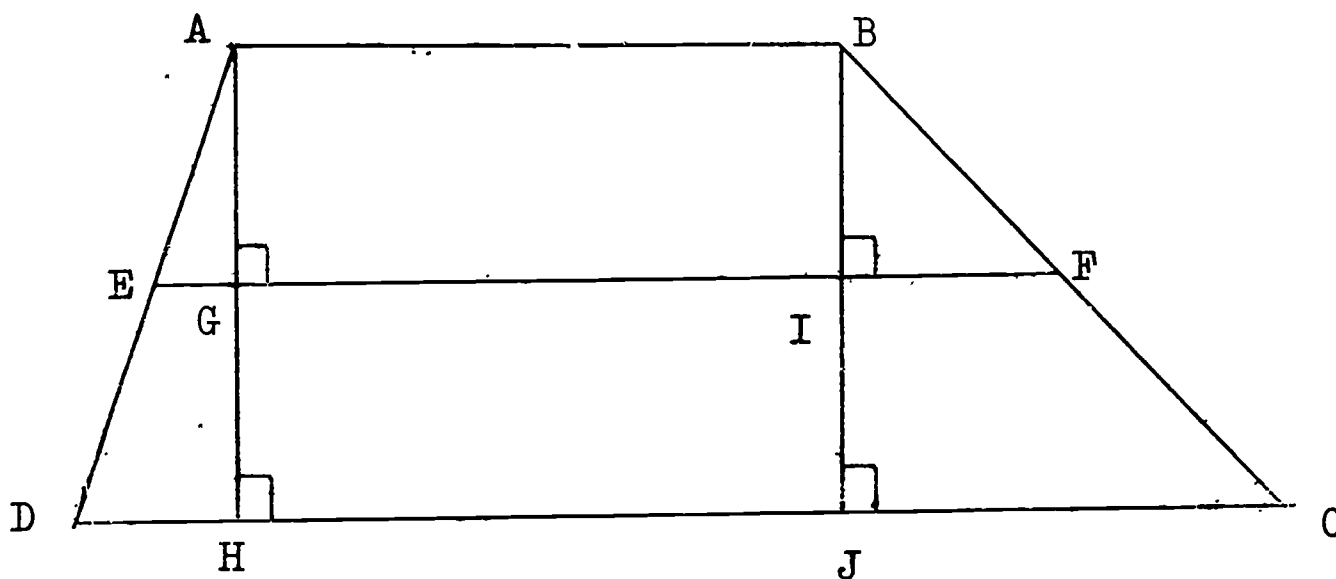

- a. $m \overline{AE} = ?$; $m \overline{ED} = ?$; What do you notice about these two measures ?
- b. Is $m \overline{AE} = (m \overline{AD}) \div 2$?
- c. $m \overline{BF} = ?$; $m \overline{FC} = ?$; What do you notice about these two measures ?
- d. Is $m \overline{BF} = (m \overline{BC}) \div 2$?
- e. $m \overline{EF} = ?$; $m \overline{AB} = ?$; $m \overline{DC} = ?$
- f. $2 \times (m \overline{EF}) = ?$; $(m \overline{AB}) + (m \overline{DC}) = ?$
- g. What do you notice in part (f) above ?
- h. $m \overline{AG} = ?$; $m \overline{BI} = ?$; What is true of these two measures ?
- i. What conclusion can you state about \overline{AB} and \overline{GI} ? about \overline{AB} and \overline{EF} ?
- j. $m \overline{GH} = ?$; $m \overline{IJ} = ?$; What is true of these two measures ?
- k. What conclusion can you state about \overline{GI} and \overline{HJ} ? about \overline{EF} and \overline{DC} ? about \overline{AB} , \overline{EF} , and \overline{DC} ?

5. Given the following figure:

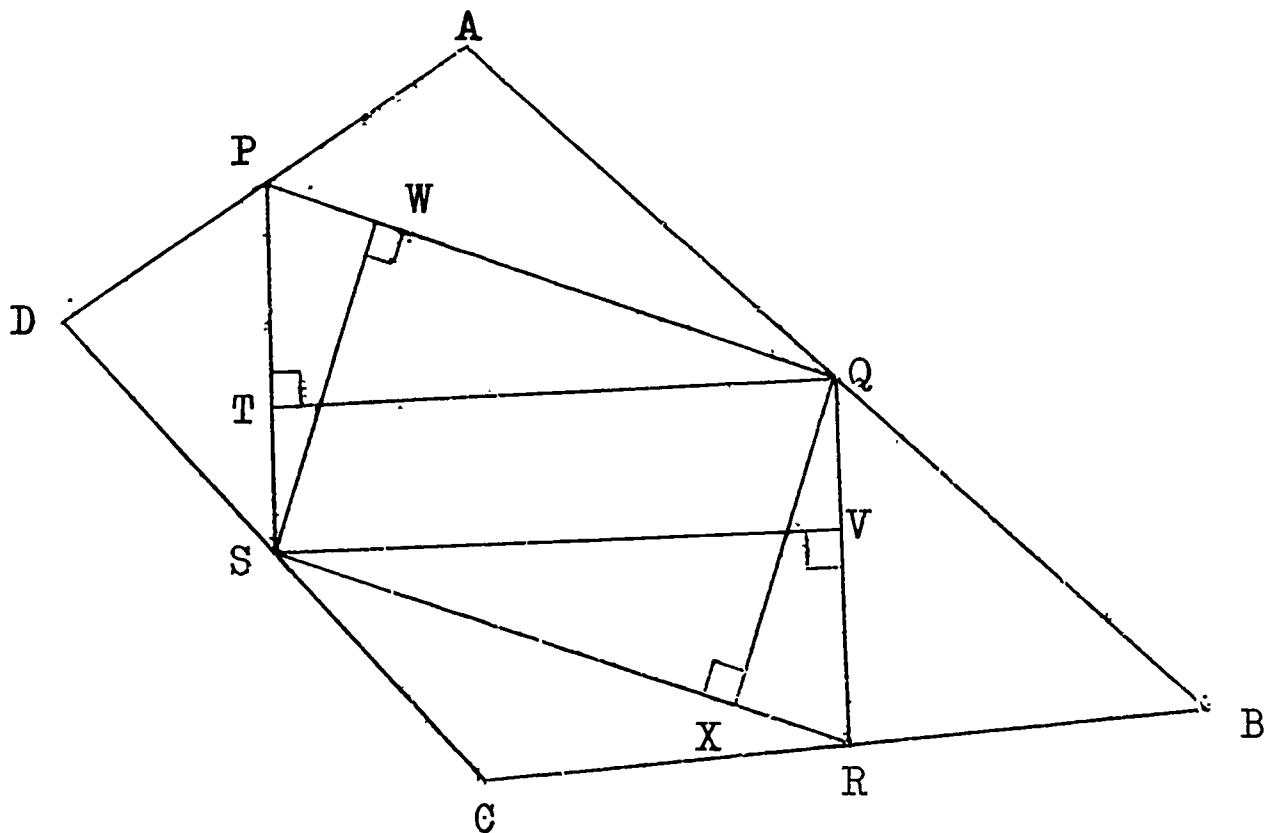

- a. $m \overline{AP} = ?$; $m \overline{PD} = ?$; What do you notice about these two measures ? ; Is $m \overline{AP} = (m \overline{AD}) \div 2$?
- b. $m \overline{AQ} = ?$; $m \overline{QB} = ?$; What do you notice about these two measures ? ; Is $m \overline{AQ} = (m \overline{AB}) \div 2$?
- c. $m \overline{BR} = ?$; $m \overline{RC} = ?$; What do you notice about these two measures ? ; Is $m \overline{BR} = (m \overline{BC}) \div 2$?
- d. $m \overline{CS} = ?$; $m \overline{SD} = ?$; What do you notice about these two measures ? ; Is $m \overline{CS} = (m \overline{CD}) \div 2$?
- e. $m \overline{TQ} = ?$; $m \overline{SV} = ?$; What is true of these two measures ?
- f. What can you conclude about \overline{PS} and \overline{QR} ?
- g. $m \overline{SW} = ?$; $m \overline{QX} = ?$; What is true of these two measures ?
- h. What can you conclude about \overline{PQ} and \overline{SR} ?
- i. $m \angle SPQ = ?$; $m \angle PQR = ?$; What is the sum of these two measures ?
- j. $m \angle PSR = ?$; $m \angle SRQ = ?$; What is the sum of these two measures ?
- k. What do you notice about $m \angle SPQ$ and $m \angle SRQ$? about $m \angle PQR$ and $m \angle PSR$?

Chapter 2

Plane Figures

2-1 What is a Plane ?

In Chapter 1 you learnt about lines, line segments, rays and angles. You learnt that these figures are determined by sets of points. When you draw one of these figures in your notebook, you are drawing it in a plane. The page of your notebook represents a part of that plane.

The surface of the blackboard is part of a plane. The top of your desk is part of a plane. Can you name other surfaces in your classroom which are parts of planes ?

Notice that a blackboard is only a part of a plane. In mathematics, a plane has no end and no thickness. Imagine the blackboard extending infinitely in all directions. The surface of this infinite blackboard is what we call a plane.

Exercises 2-1

1. Name five different surfaces in your classroom which represent portions of a plane.
2. Given a point A.
 - a. Is there one plane which contains point A ?
 - b. Is there a second plane which also contains point A ?
 - c. Is there a third plane which also contains A ? a fourth plane? ... a fifth plane? ... a tenth plane?
 - d. How many different planes are there which contain A ?
3. Given a line AB.
 - a. Is there one plane which contains \overleftrightarrow{AB} ?
 - b. Is there a second plane which also contains \overleftrightarrow{AB} ?
 - c. Is there a third plane which also contains \overleftrightarrow{AB} ? a fourth plane? ... a fifth plane? ... a hundredth plane ?
 - d. How many different planes are there which contain \overleftrightarrow{AB} ?

4. Given three points A, B and C.
- Is there one plane which contains all three points A, B and C ?
 - Can you draw a second plane which also contains the three points A, B and C ?
 - What is the minimum number of points which you need to determine exactly one plane ?
5. Given four points D, E, F and G.
- Is there exactly one plane which contains all four points D, E, F and G ?
 - Can there be no plane which contains all four points D, E, F and G ?
 - Can there be one plane which contains all four points ?
 - Can there be two planes which contain all four points ?
three planes ?
 - What is the maximum number of different planes which contain any three of the four points D, E, F and G ?

2-2 More About Angles

Look at this picture:

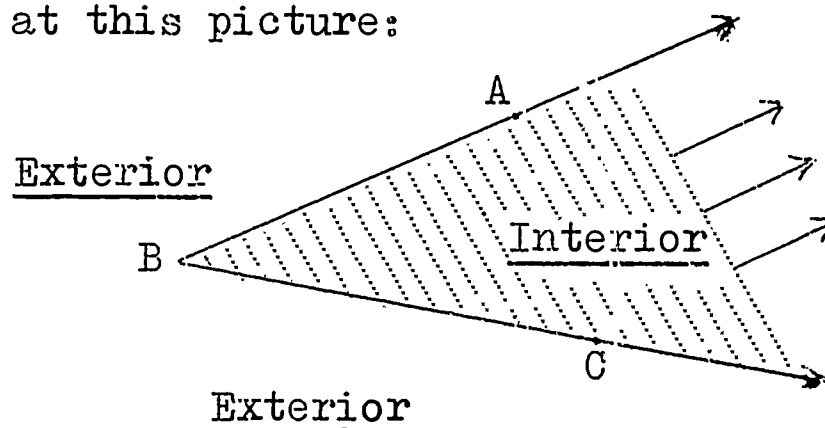

In figure (1), $\angle ABC$ separates the plane of this page into three sets of points:

- $\angle ABC$
- The interior of $\angle ABC$
- The exterior of $\angle ABC$

Now look at this picture:

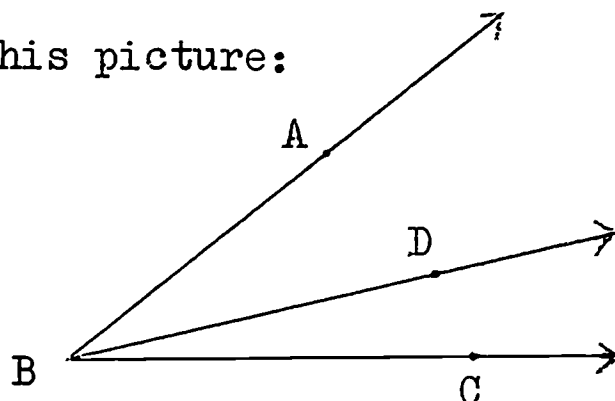

(2)

In figure (2), notice that \overrightarrow{BD} lies in the interior of $\angle ABC$. The endpoint of \overrightarrow{BD} is the vertex of $\angle ABC$. We say that \overrightarrow{BD} lies between \overrightarrow{BA} and \overrightarrow{BC} .

In figure (3), \overrightarrow{RS} is between \overrightarrow{RT} and \overrightarrow{RV} .

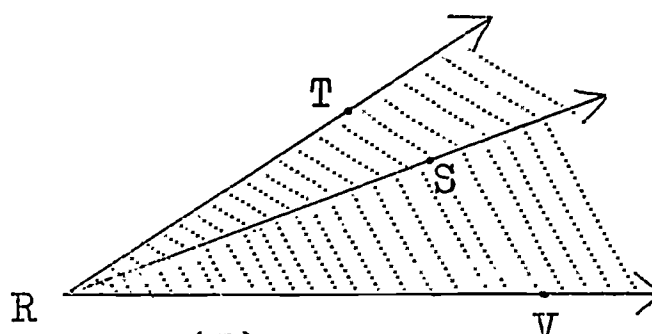

(3)

Notice that the interior of $\angle TRS$ has no points in common with the interior of $\angle SRV$. $\angle TRS$ is adjacent to $\angle SRV$ in figure (3). Two angles with a common vertex and a common side are called adjacent angles if their interiors do not intersect.

Look at this picture:

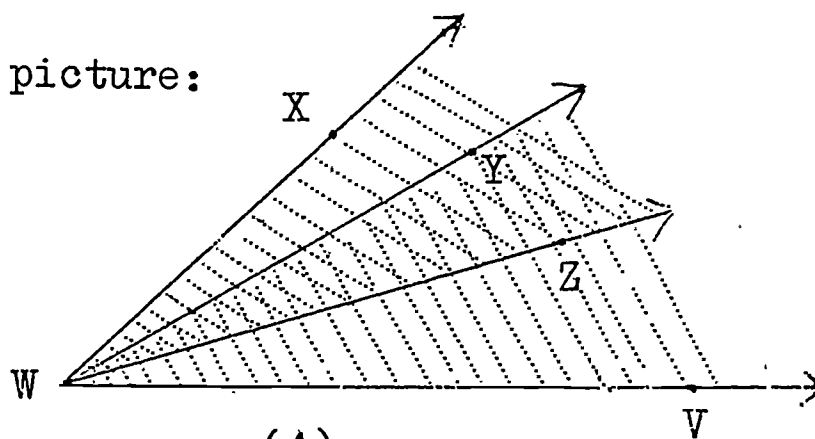

(4)

In figure (4), $\angle YWV$ is not adjacent to $\angle XWZ$ because their interiors intersect. We also say that the angles YWV and XWZ overlap in figure (4).

Look at this picture:

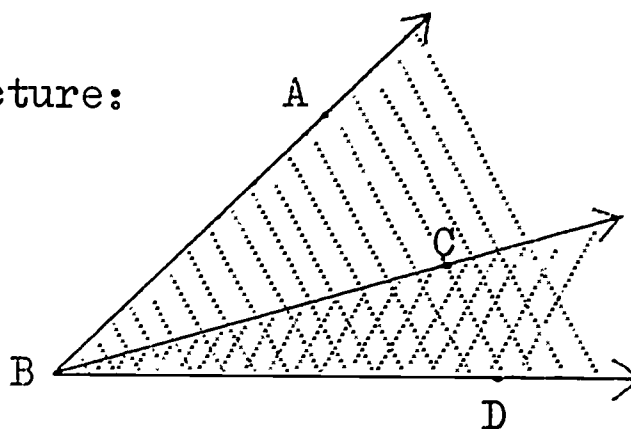

(5)

In figure (5), $\angle ABD$ is not adjacent to $\angle CBD$ because their interiors intersect. $\angle ABD$ and $\angle CBD$ are overlapping angles.

Adjacent angles have a common vertex, a common side, and the intersection of their interiors is the empty set.

In figure (6), line AC intersects line DF at point B:

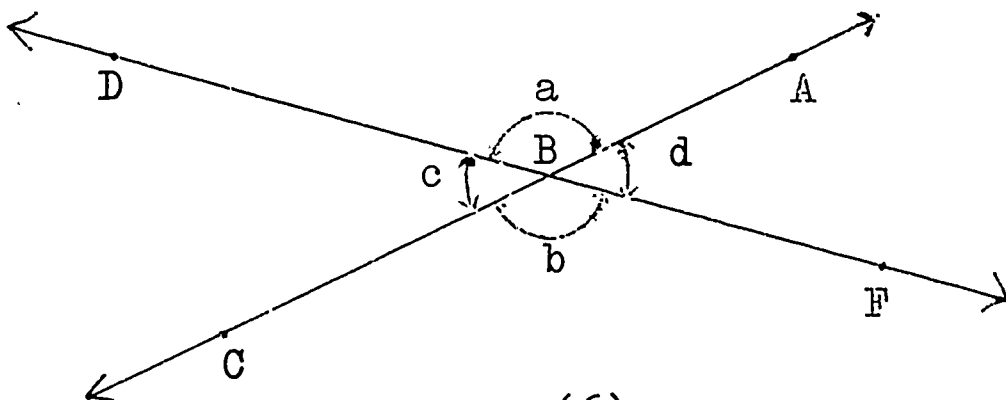

(6)

$\angle a$ and $\angle b$ are called vertically opposite angles.

$\angle c$ and $\angle d$ are called vertically opposite angles.

When two lines intersect, the pairs of opposite angles thus formed are called vertically opposite angles.

Measure $\angle a$ and $\angle b$. What do you find? Measure $\angle c$ and $\angle d$. What do you find?

Do you think that vertically opposite angles have the same measure?

When two lines intersect, the opposite angles thus formed are called vertically opposite angles.

If the sum of the measures of two angles is 90, then those angles are called complementary angles. In figure (7), $\angle ABC$ and $\angle RST$ are complementary angles. Why?

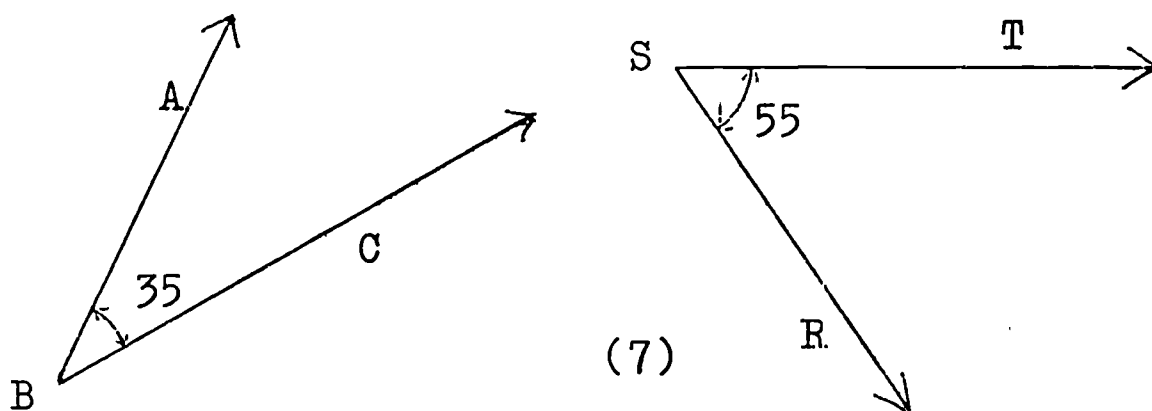

In figure (8), $\angle SYZ$ is a right angle.

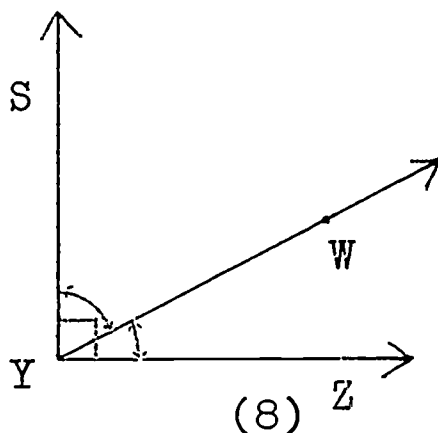

What is the measure of a right angle? Notice that $\angle SYW$ and $\angle WYZ$ are adjacent angles which form a right angle. Are they complementary? Why?

If the sum of the measures of two angles is 180, then those angles are called supplementary angles. In figure (9), are $\angle ABC$ and $\angle EFG$ supplementary? Why?

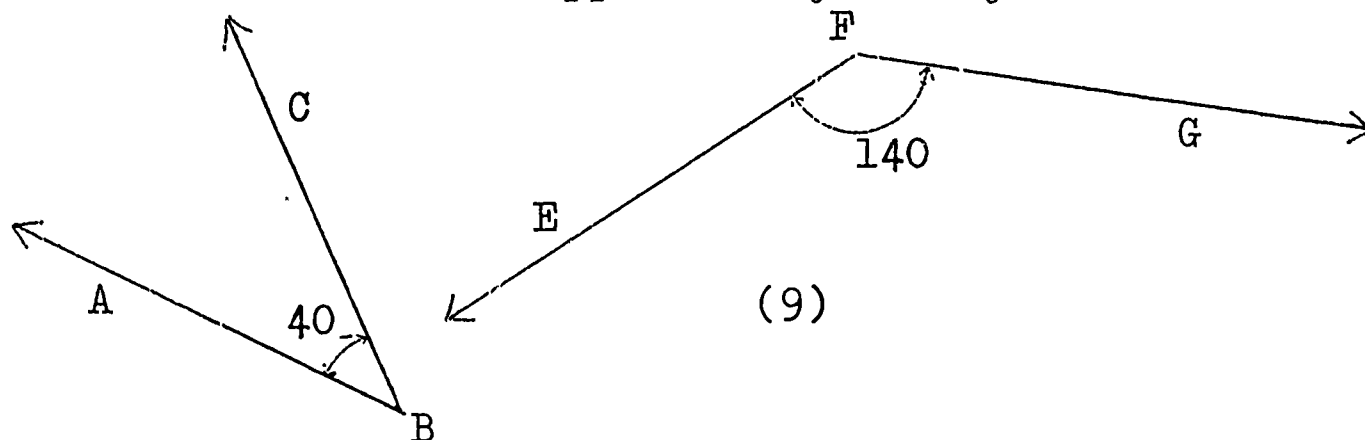

In figure (10), $\angle RST$ is a straight angle.

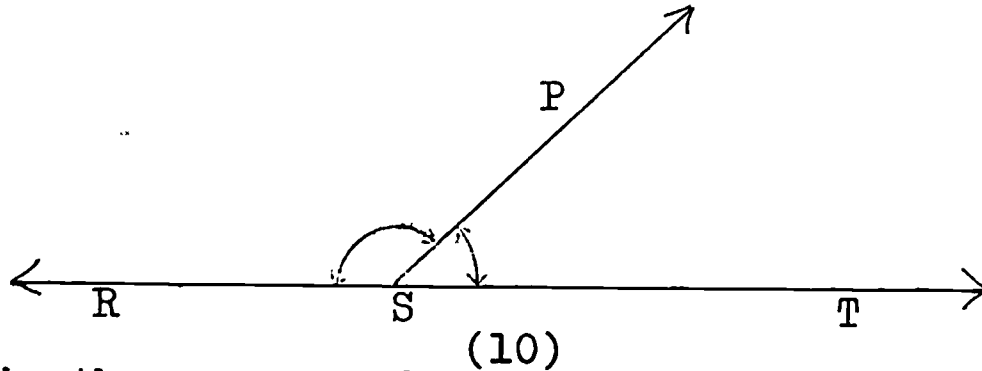

What is the measure of a straight angle? Notice that $\angle RSP$ and $\angle PST$ are adjacent angles which form a straight angle. Are $\angle RSP$ and $\angle PST$ supplementary? Why?

- (1) Two angles are complementary when the sum of their measures is 90.
- (2) Two angles are supplementary when the sum of their measures is 180.

Exercises 2-2

1. Complete the following table by writing the correct number for the measure of the angle: Write all work in your notebook.

	$m \widehat{ABC}$	Measure of complement of $\angle ABC$	Measure of supplement of $\angle ABC$
a.	25	-	-
b.	-	42	-
c.	-	-	120
d.	53	-	-
e.	-	62	-
f.	119	-	-
g.	-	-	74
h.	17	-	-
i.	-	9	-
j.	-	-	154

2. Given $P = \{15^\circ, 56^\circ, 78^\circ, 105^\circ, 146^\circ\}$ and
 $Q = \{102^\circ, 34^\circ, 165^\circ, 124^\circ, 75^\circ\}$.

Pair members of P with members of Q so that the pairs are:

- supplementary .
 - complementary .
3. a. Draw any angle ABC into your notebook.
 b. Draw a ray BD in the interior of $\angle ABC$.
 c. Draw another ray BE in the exterior of $\angle ABC$.
 d. Is $\angle DBC$ in the interior of $\angle ABE$?
 e. Draw \overline{AE} . Does \overline{AE} intersect \overrightarrow{BD} ? Does \overline{AE} intersect \overrightarrow{BC} ?
 f. Draw \overline{ED} . Does \overline{ED} intersect \overrightarrow{BC} ? Does \overline{ED} intersect \overrightarrow{BA} ? Is \overrightarrow{BA} in the interior of $\angle DBE$?

4. Given the following figure:

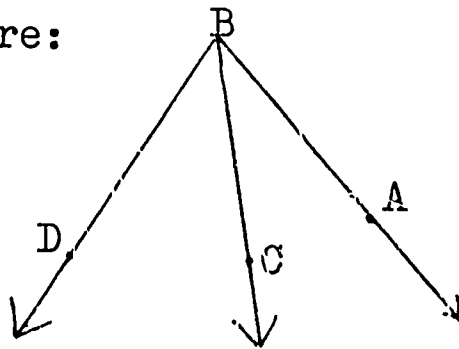

- Name a pair of adjacent angles in the figure.
 - Name a pair of angles which are not adjacent angles in the figure.
 - If $m \widehat{ABD} = 82$ and $m \widehat{CBD} = 42$, then $m \widehat{ABC} = \underline{\hspace{2cm}}$.
5. a. Draw a right angle DEF .
 b. Draw a ray EG in the interior of $\angle DEF$.
 c. What are the angles DEG and GEF called ?
 d. What is the sum of the measures of angles DEG and GEF ?
 e. If $m \angle GEF = 20$, then $m \angle DEG = ?$
 f. If $m \angle GEF = 37$, then $m \angle DEG = ?$
 g. If $m \angle GEF = a$, then $m \angle DEG = ?$

6. Given the following figure in which \overleftrightarrow{EF} and \overleftrightarrow{AC} are lines, and $\overline{DB} \perp \overleftrightarrow{AC}$ at B .

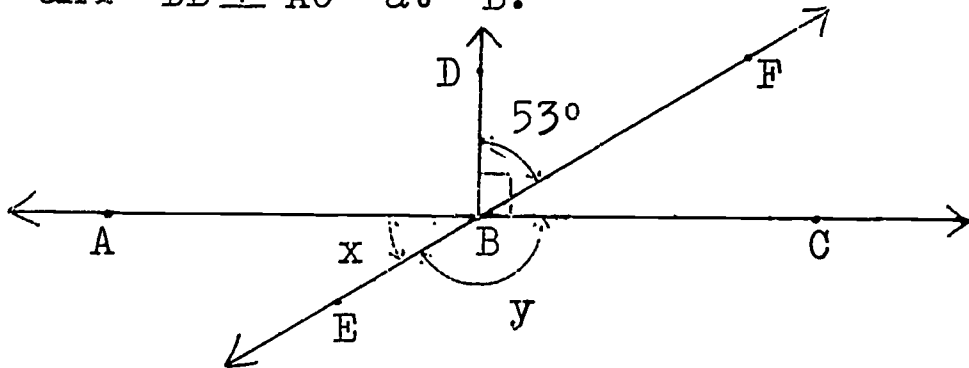

- a. Without measuring, find $m \angle x$ and $m \angle y$.
7. a. Draw a straight angle XYZ .
 b. Draw a ray YW .
 c. What are the angles $\angle XYW$ and $\angle WYZ$ called?
 d. What is the sum of the measures of $\angle XYW$ and $\angle WYZ$?
 e. If $m \widehat{XYW} = 120$, then $m \widehat{WYZ} = ?$
 f. If $m \widehat{XYW} = 72$, then $m \widehat{WYZ} = ?$
 g. If $m \widehat{XYW} = a$, then $m \widehat{WYZ} = ?$
8. Given the following figure:

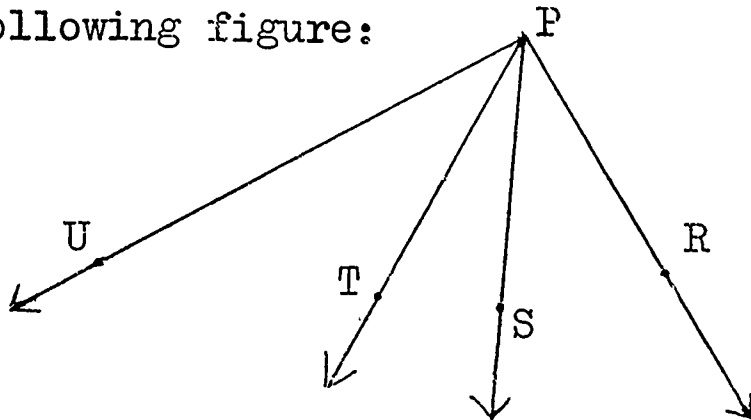

- a. Name a ray between \overline{PS} and \overline{PU} .
- b. Name a point in the exterior of $\angle TPU$.
- c. What is the intersection of the interior of $\angle RPS$ and the interior of $\angle TPU$?
- d. What is the intersection of the interior of $\angle SPU$ and the interior of $\angle TPU$?
- e. If $m \widehat{RPS} = 32$, $m \widehat{SPT} = 27$, and $m \widehat{RPU} = 108$, then:
 $m \widehat{RPT} = \underline{\hspace{2cm}}$; $m \widehat{TPU} = \underline{\hspace{2cm}}$; $m \widehat{SPU} = \underline{\hspace{2cm}}$.

9. a. If one of two complementary angles has a measure of 45° , then the other angle has a measure of _____ .
- b. If one of two supplementary angles has a measure of 105° , then the other angle has a measure of _____ .
- c. The measure of one of two complementary angles is 21 less than twice the measure of the other. Find the measure of each angle.
- d. The measure of one of two supplementary angles is 20 more than 3 times the measure of the other. Find the measure of the smaller angle.
- e. The measure of the supplement of an acute angle is 3 times the measure of the complement. Find the measure of the angle.

2-3 Closed Plane Figures

Place your pencil on a piece of paper. Now without lifting your pencil, draw any figure you like. Your figure might look like one of these:



(a)



(b)

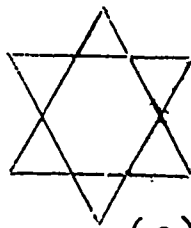

(c)

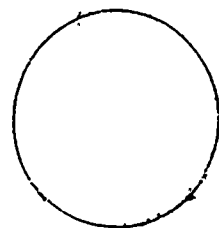

(d)

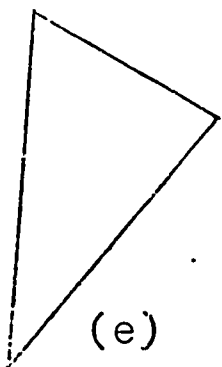

(e)



(f)



(g)

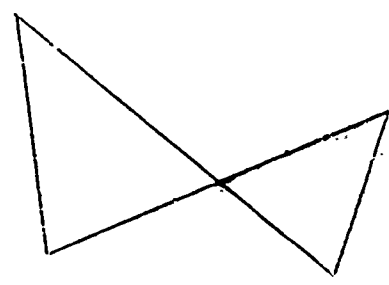

(h)

(1)

Each of the figures in (1) above is called a curve.

On page 71, figures b, d, e, f and g are called simple curves. A simple curve does not intersect itself.

Figures d, e and g are called simple closed curves. A simple closed curve does not intersect itself; a simple closed curve must return to the starting point.

If you draw a simple closed curve, will your pencil point ever leave the paper? Will your pencil point ever cross a part of the curve already drawn? Will your pencil point return to the starting point?

Here are pictures of more curves which are not simple closed curves. Why is each curve in figure (2) not a simple closed curve?

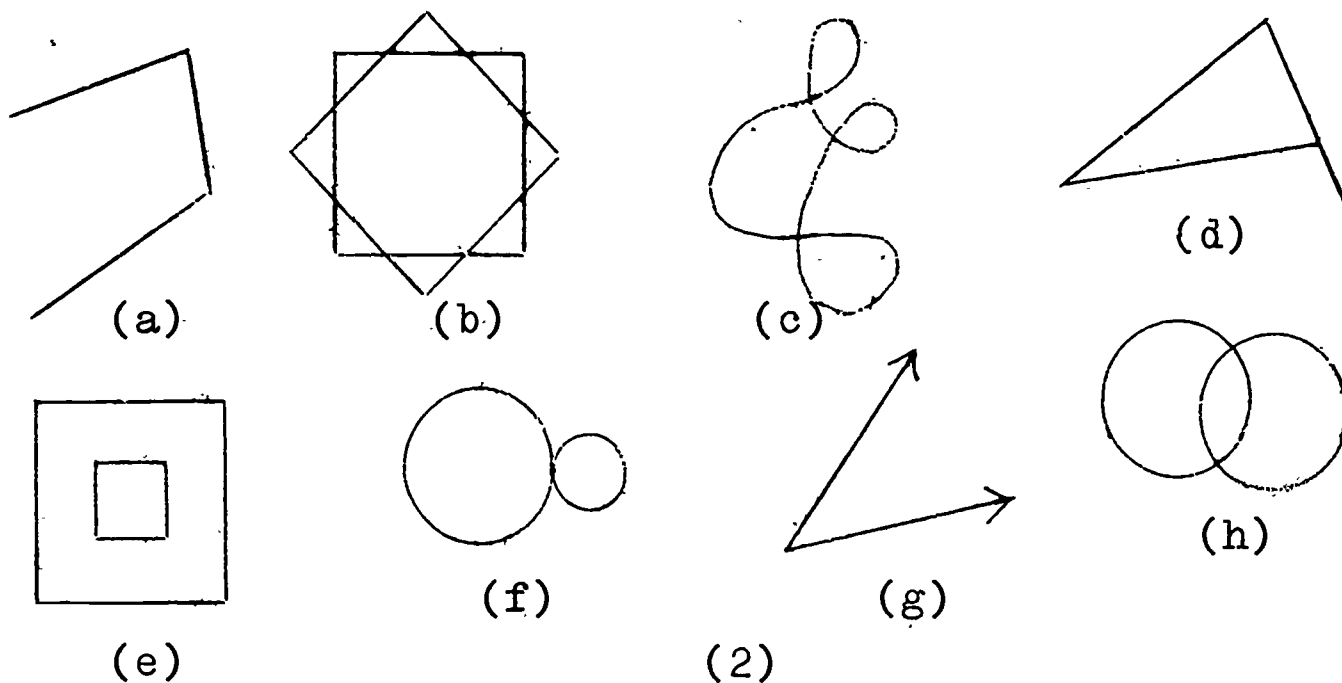

Consider a simple closed curve as in figure (3), and draw line segments connecting points on the curve as in figure (4):

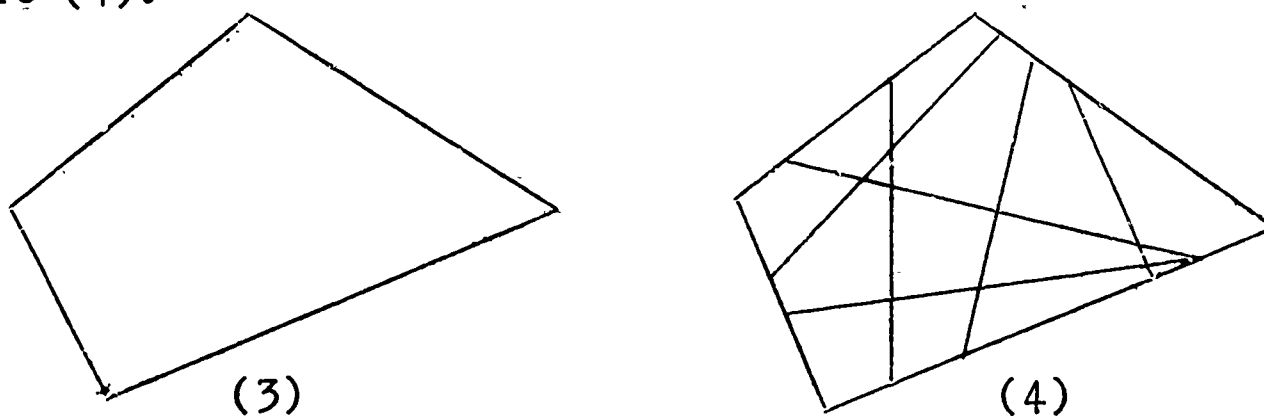

If all possible segments were drawn in figure (4), the picture would look like this:

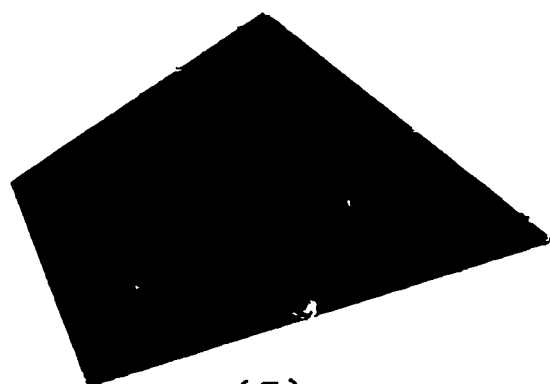

(5)

The figure in (5) is called a region. A region is the union of a simple closed curve and its interior. Here are pictures of some more regions:

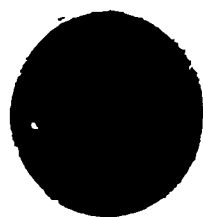

(a)



(b) (6)



(c)

The curve which determines the region is part of the region. Points which are not in the region are in the exterior of the region.

Exercises 2-3

1. State whether each figure is a simple closed curve or not a simple closed curve:

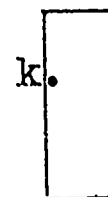
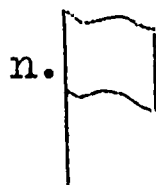
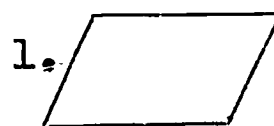
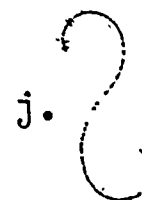
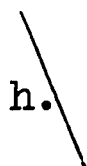
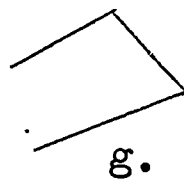
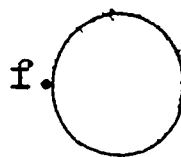
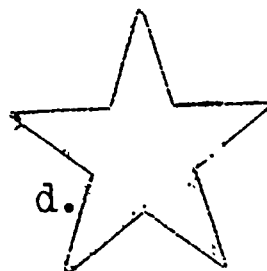
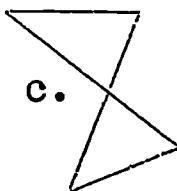
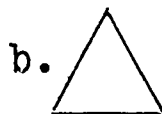
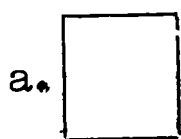

2. a. Draw any simple closed curve in your notebook.
 b. Take any point A in the interior of your curve.
 c. Take any point B in the exterior of your curve.
 d. Draw the line segment AB.
 e. Does \overline{AB} intersect the curve? What is the intersection:
 a point? a line? a curve? a plane?
3. a. Into how many different subsets of a plane does a simple closed curve separate the plane?
 b. What are these different subsets?
4. Copy the following simple closed curve into your notebook:

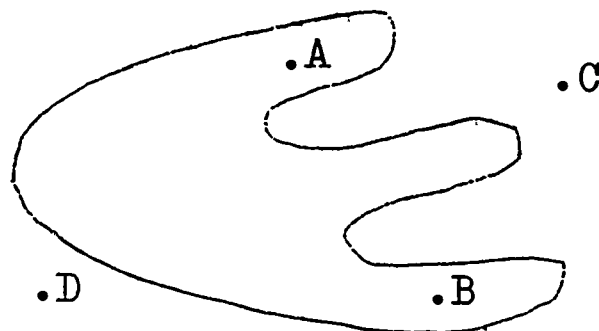

Without lifting your pencil point from the paper, and without intersecting the figure, can you draw a curve from:

- a. point A to point B?
- b. point A to point C?
- c. point C to point D?
- d. Are points A and B in the interior of the curve?
- e. Where are the points C and D?

2-4 Polygons

In the last section, you learnt about simple closed curves. Let us now consider simple closed curves made up of line segments. A simple closed curve made up of line segments is called a polygon.

Here are pictures of some polygons:

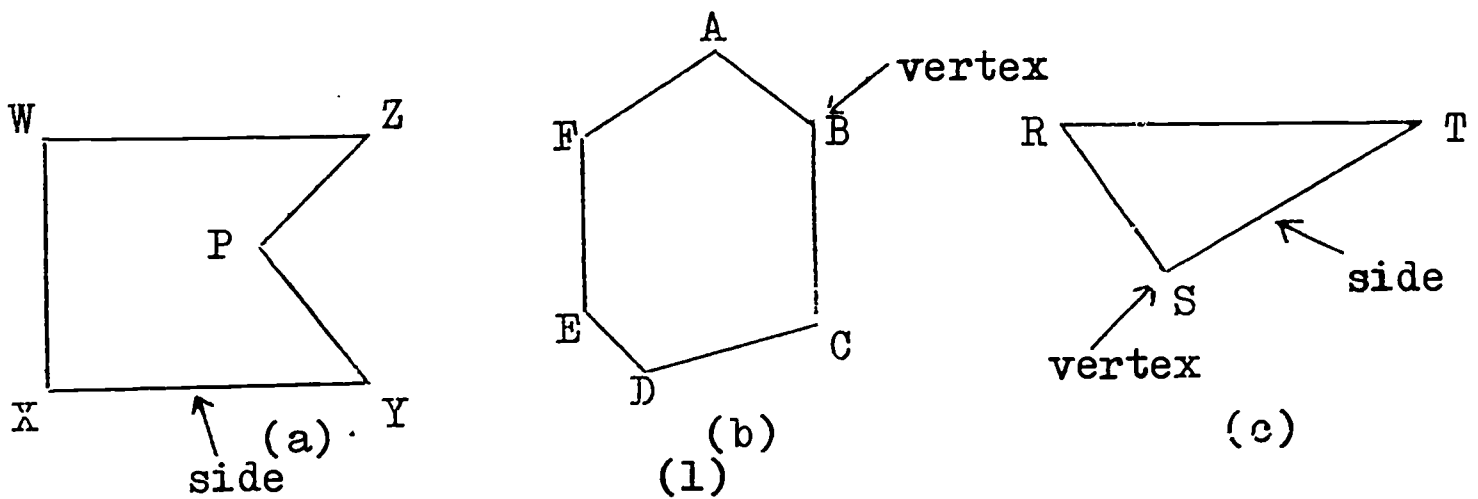

A polygon is a simple closed curve which is the union of line segments. For example, in figure (1)

$$\text{Polygon RST} = \overline{RS} \cup \overline{ST} \cup \overline{TR}$$

The line segments of a polygon intersect only at their endpoints. The line segments are called the sides of the polygon.

The endpoints of the line segments are called the vertices of the polygon. How many sides does polygon (1a) have? How many vertices does it have? What is the relation between the number of sides and the number of vertices of a polygon?

Here are some pictures of curves which are not polygons. Why is each curve in figure (2) not a polygon?

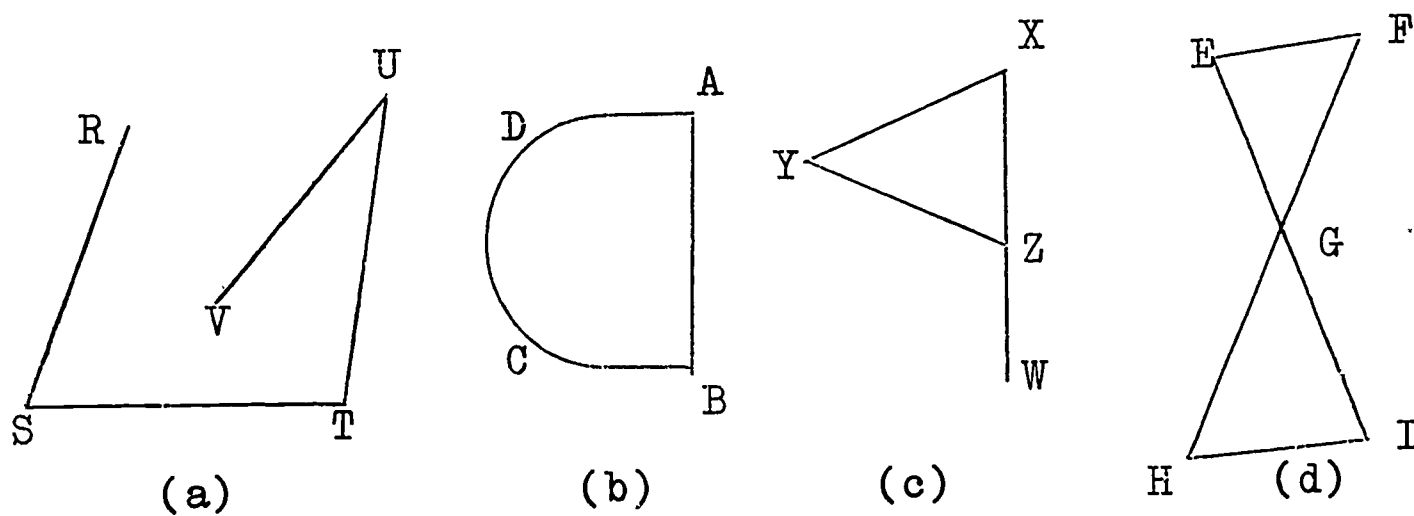

(2)

Look at polygon RSTU:

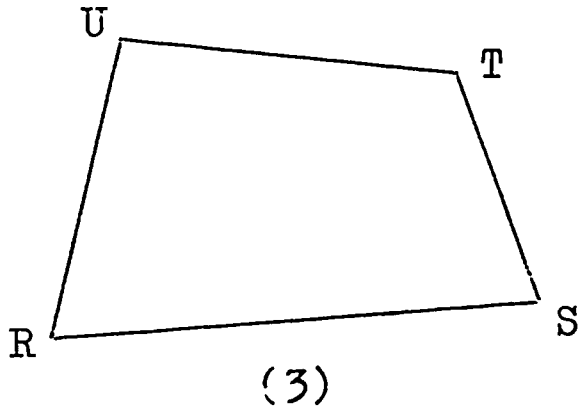

Notice that we name the polygon by naming the vertices in order around the polygon.

UTSR is another name for the polygon in figure (3). However, USTR is not a name for the polygon in figure (3). How many names can you write for the polygon RSTU ?

Notice in figure (3) that:

$$\overline{UR} \cup \overline{RS} = \angle URS .$$

Since there is only one angle with vertex R, we often write $\angle R$ for $\angle URS$. What is another name for $\angle S$? What is another name for $\angle RUT$?

Exercises 2-4

1. State which figures are polygons, and which are not polygons:

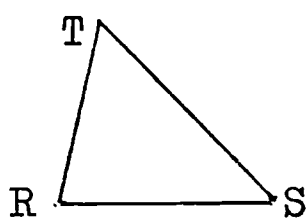

a.

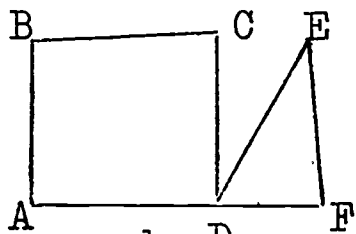

b.

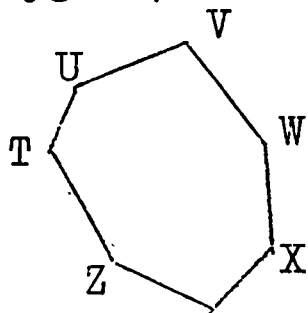

c.

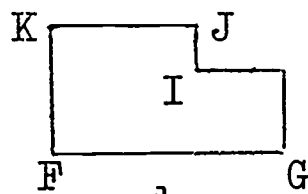

d.

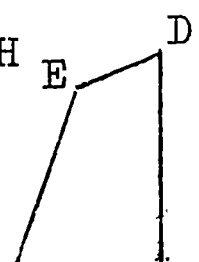

e.

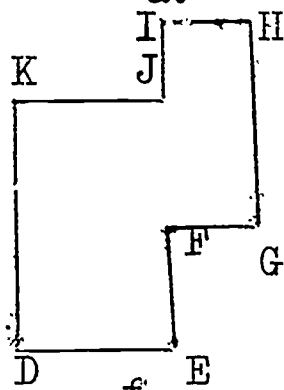

f.

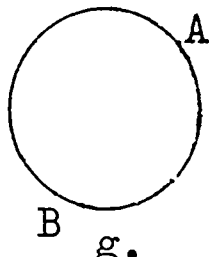

g.

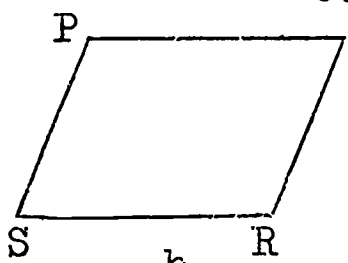

h.

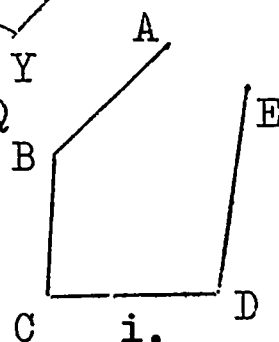

i.

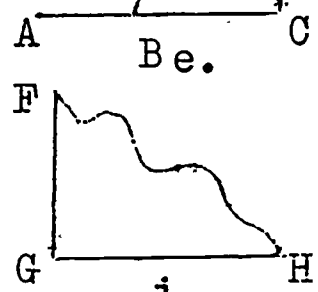

j.

2. Write two different names for each of those figures which are polygons in Exercise (1) above.

3. Which of the following are correct names for this polygon ?

- | | | |
|---------|---------|---------|
| a. DEFG | d. FDEG | g. EFGD |
| b. DEGF | e. FEDG | h. EDGF |
| c. GFED | f. GEFD | i. EFDG |

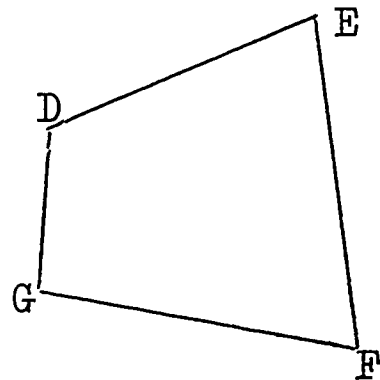

4. Copy each of the following figures into your notebook. Then answer the questions asked.

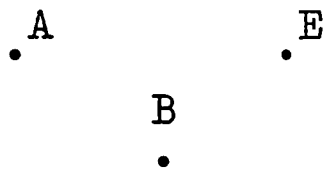

- a. Draw polygon
ABCDE.

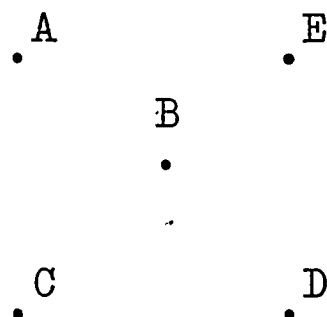

- b. Draw polygon
ACDBE.

5. Copy the following figure into your notebook. Then answer the questions asked.

- a. Draw curve ADCBEF. Is this a polygon ? Why ?

- b. Copy the figure again and draw

AFEDCB. Is this a polygon ? Why ?

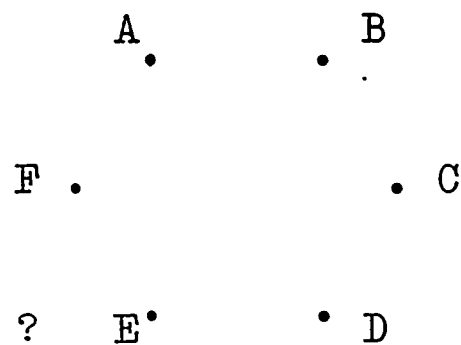

6. A polygonal region is the union of a polygon and its interior. Here is a picture of a polygonal region:



Copy each of these figures into your notebook, and then answer the questions asked:

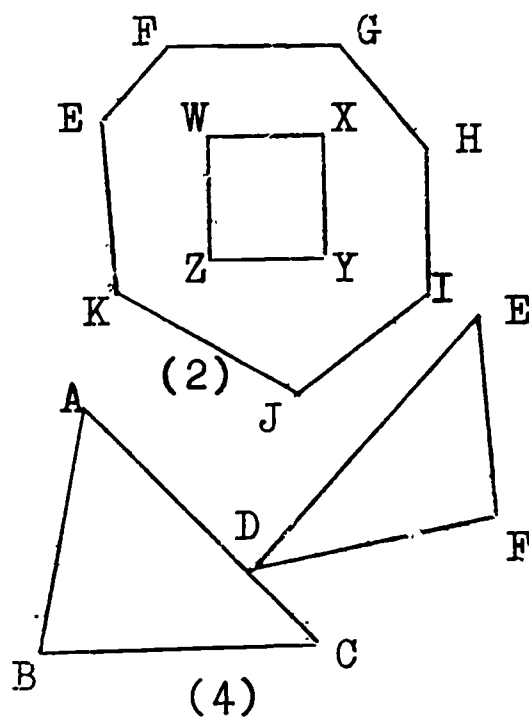
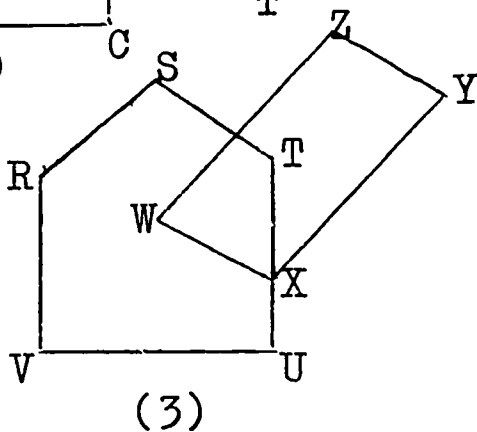
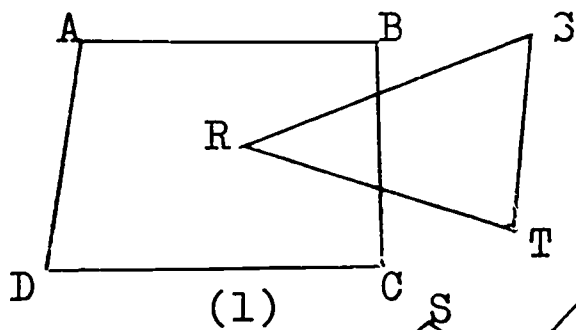

- In figure (1), shade $(\text{Region } ABCD) \cap (\text{Region } RST)$. Is the intersection also a polygonal region? Why?
- In figure (2), shade $(\text{Region } EFGHIJK) \cap (\text{Region } WXYZ)$. Is the intersection also a polygonal region? Why?
- In figure (3), shade $(\text{Region } RSTUV) \cup (\text{Region } WXYZ)$. Is the union also a polygonal region? Why?
- In figure (4), shade $(\text{Region } ABC) \cup (\text{Region } DEF)$. Is the union also a polygonal region? Why?
- In figure (4), is $(\text{Region } ABC) \cap (\text{Region } DEF)$ a polygonal region? Why?

2-5 Triangles

In Section 2-4, you studied simple closed curves called polygons. A polygon with exactly three sides is called a triangle. Here is a picture of a triangle:

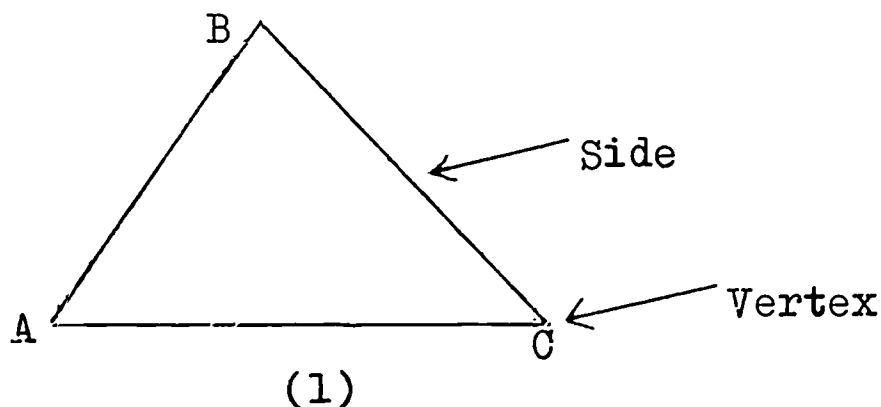

We call the polygon in figure (1) "triangle ABC" or " $\triangle ABC$ ". Triangle ABC is the union of three segments: \overline{AB} , \overline{BC} , and \overline{CA} . We write:

$$\triangle ABC = \overline{AB} \cup \overline{BC} \cup \overline{CA} .$$

Notice that the segments intersect only at their endpoints. Points A, B and C are the vertices of $\triangle ABC$.

Segments \overline{AB} , \overline{BC} and \overline{CA} are the sides of $\triangle ABC$.

The word "triangle" means "three angles". The three angles in $\triangle ABC$ are $\angle BAC$, $\angle ACB$, and $\angle CBA$. We can write: $\angle BAC = \angle A$, $\angle ACB = \angle C$, and $\angle CBA = \angle B$.

$\triangle ABC$ in figure (1) is a set of points. $\triangle BCA$ is the same set of points. Hence $\triangle BCA$ is another name for $\triangle ABC$. There are six names for $\triangle ABC$. Can you write all six names ?

We classify triangles according to the measures of their angles. On the next page are pictures of triangles classified according to their angles.

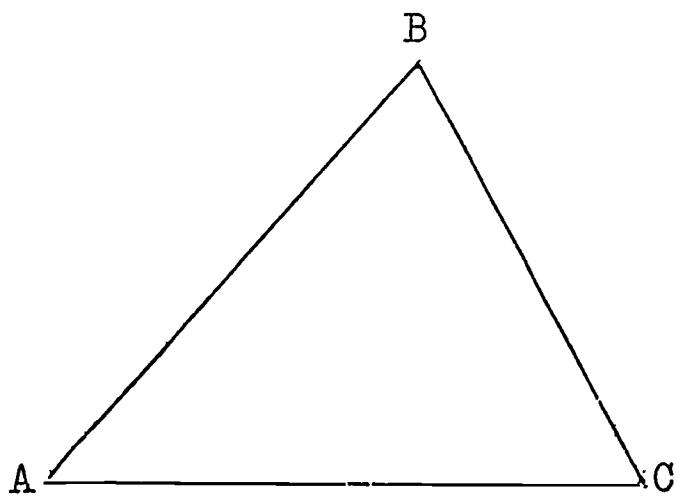

Acute Triangle
All angles are acute

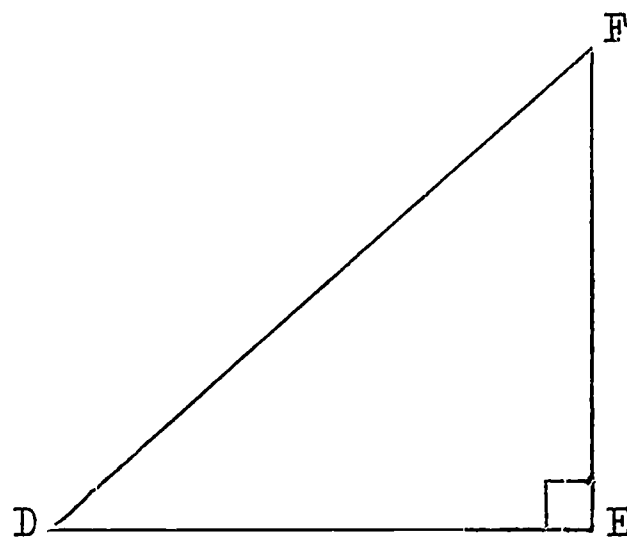

Right Triangle
One right angle

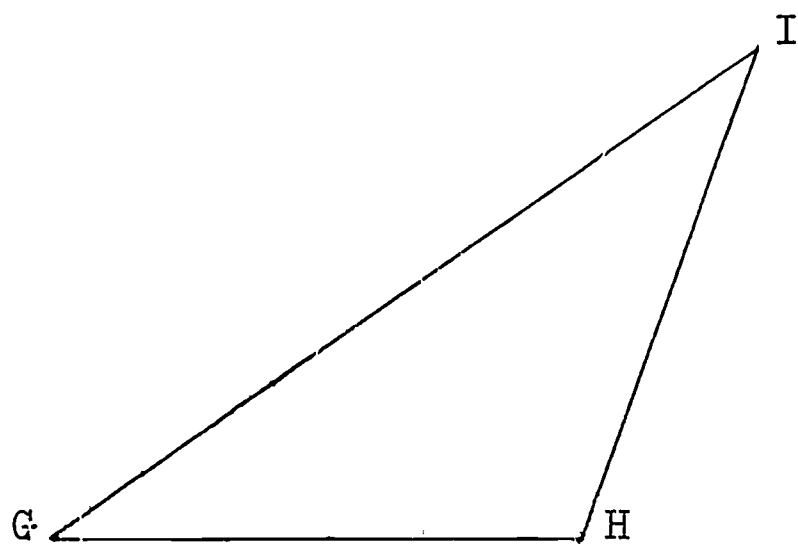

Obtuse Triangle
One obtuse angle

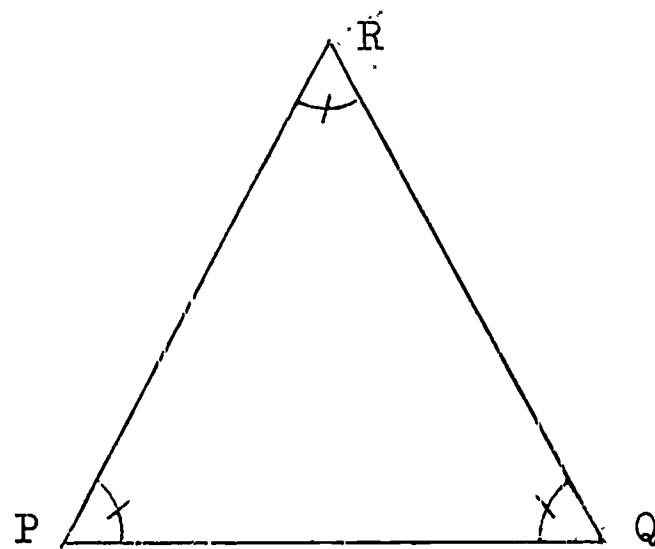

Equiangular Triangle
 All angles have equal
 measure

(1)

We also classify triangles according to the measures of their sides. Here are pictures of triangles classified according to their sides:

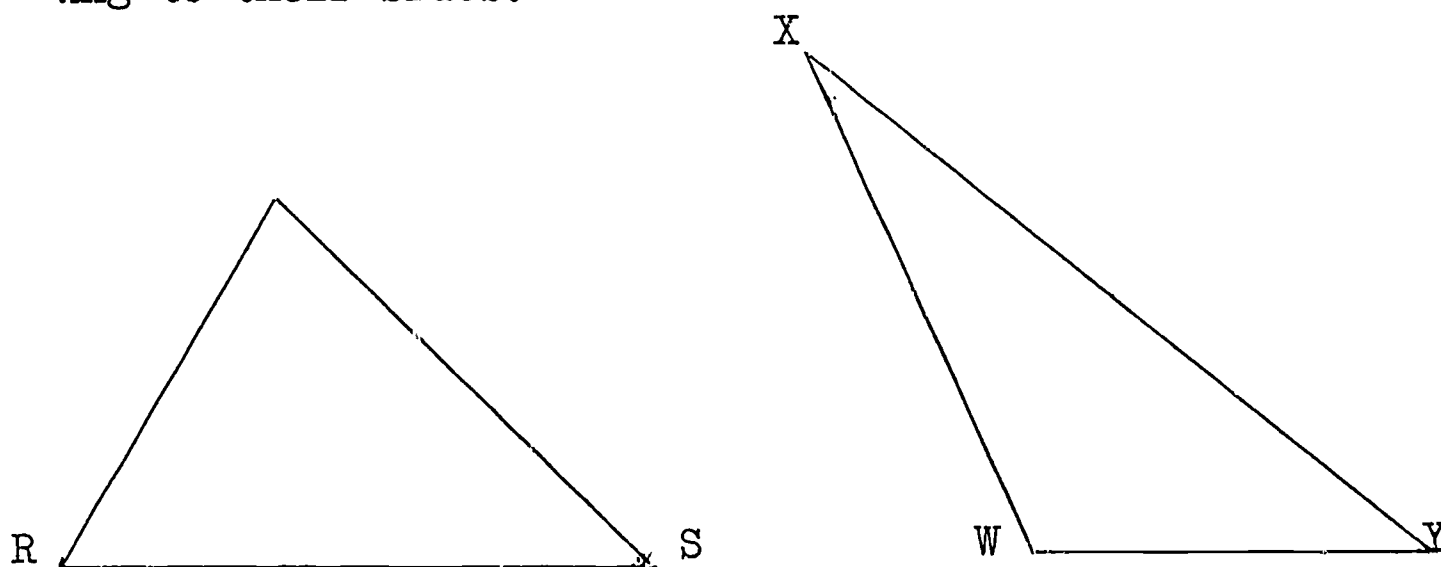

Scalene Triangles
No two sides have the same measure

(2)

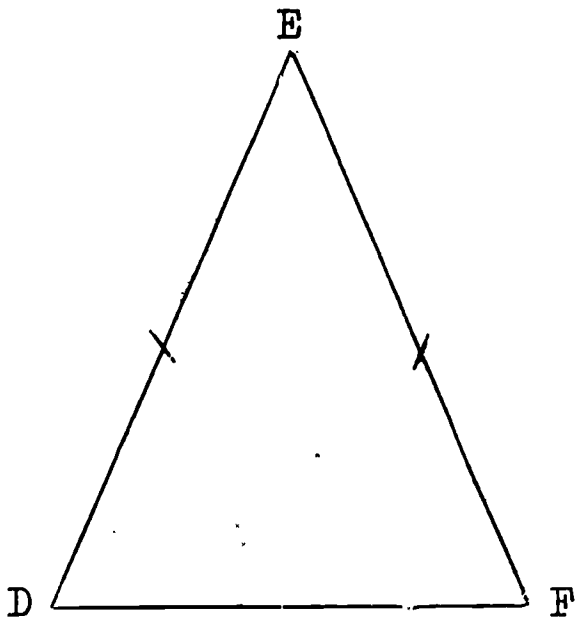

Isosceles Triangle
Two sides have the same measure.

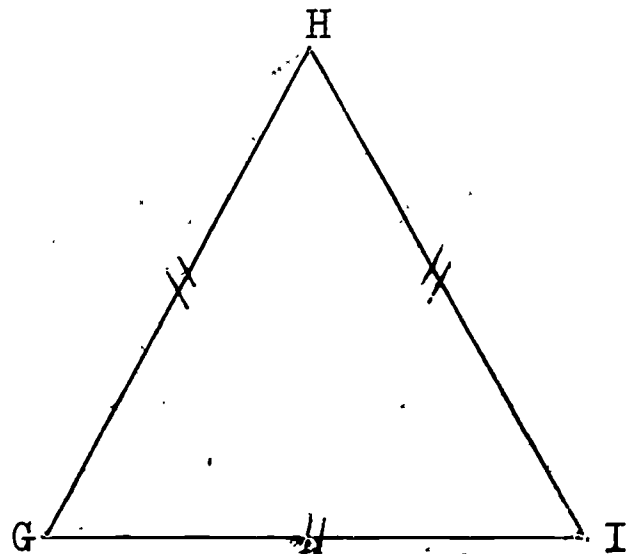

Equilateral Triangle
All sides have the same measure.

(3)

Every equilateral triangle is also isosceles. Why? Notice the mark on \overline{DE} and \overline{EF} in $\triangle DEF$. The marks indicate that the sides have the same measure. What do you think the marks on \overline{GH} , \overline{HI} , and \overline{IG} mean? On $\angle P$, $\angle Q$, and $\angle R$ of figure (1)?

Now look at this figure:

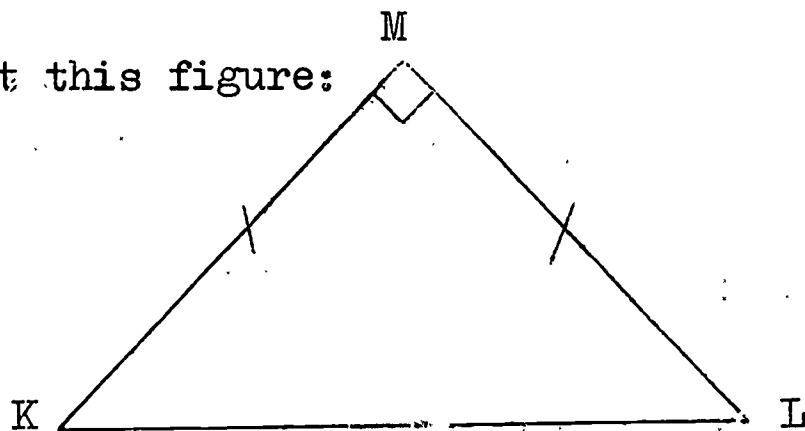

Isosceles Right Triangle

(4)

In figure (4), $\triangle KLM$ is an isosceles right triangle because $m\overline{KM} = m\overline{ML}$ and $\angle M$ is a right angle.

When you are asked to draw any triangle, you should draw a scalene triangle. Otherwise, you are drawing one of the special triangles pictured above.

Measure the angles of each triangle in figures (1), (2), (3) and (4) above. Add the measures of the angles of each triangle. What is the sum of the measures of the angles in each triangle? Is the sum of the measures of the angles in each triangle 180? Do you think that the sum of the measures of the angles of every triangle is 180? If you measure very accurately, you will indeed find that the sum of the measures of the angles of any triangle is 180.

The sum of the measures of the angles in any triangle is 180.

Do you think that a triangle can have more than one right angle? Can a triangle have more than one obtuse angle?

Exercises 2-5

1. a. In $\triangle RST$, $m\angle R = 60$, $m\angle S = 70$. $m\angle T = ?$
- b. In $\triangle XYZ$, $m\angle X = 2m\angle Y$. $m\angle Y = 40$. $m\angle Z = ?$
- c. In $\triangle ABC$, $m\angle A = m\angle B = 35$. $m\angle C = ?$
- d. In each of the following figures, find x :

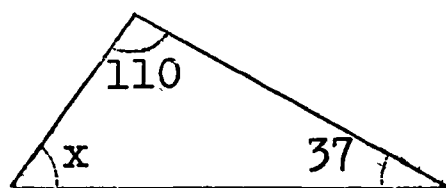

i.

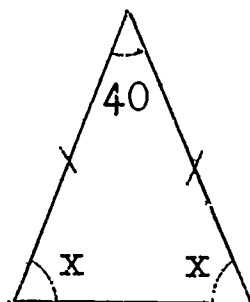

ii.

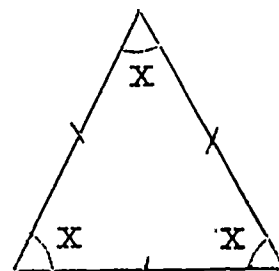

iii.

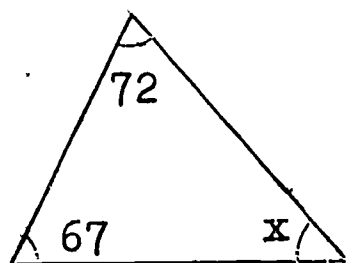

iv.

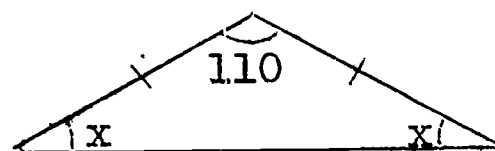

v.

2. a. In your notebook, draw any triangle ABC .
 b. Name the side opposite $\angle A$.
 c. Name the angle opposite side \overline{AC} .
 d. Name the angle opposite side \overline{BC} .
 e. Name the side opposite $\angle B$.
 f. How many angles does a triangle have? How many sides?
 g. On your figure, shade the region of $\triangle ABC$.
 h. Are the points A , B and C in the interior of $\triangle ABC$?
 in the exterior of $\triangle ABC$? on $\triangle ABC$?

3. Classify each of the following triangles according to its sides or angles:

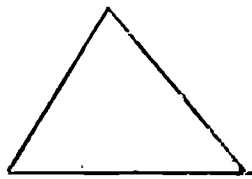

a.

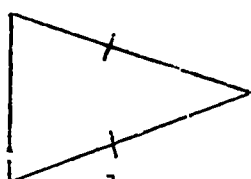

b.

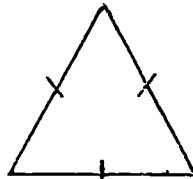

c.

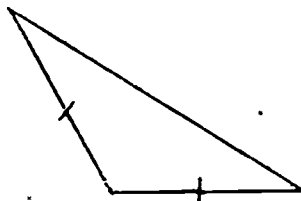

d.

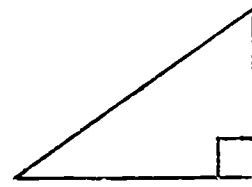

e.

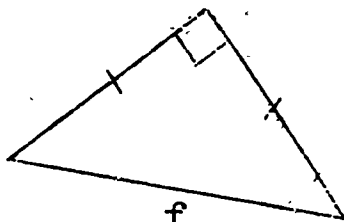

f.

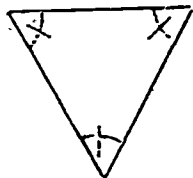

g.

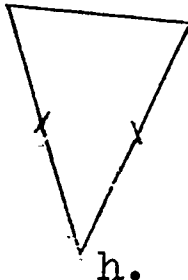

h.



i.

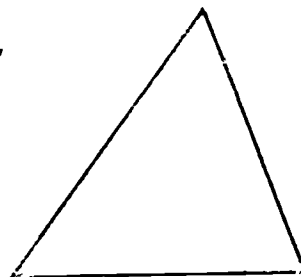

j.

4. Draw the following figure into your notebook from the directions given, then answer the questions asked:
 a. Draw a line segment AB 2.5 inches long.
 b. Draw a ray AQ such that $m\angle BAQ = 60$.
 c. Draw a ray BR such that $m\angle ABR = 60$.
 d. Label the point of intersection of \overline{AQ} and \overline{BR} point C .
 e. What kind of triangle is $\triangle ABC$?
 f. Check your answer in part (e) by measuring $\angle ACB$ and by measuring \overline{BC} and \overline{AC} .
 g. What is the sum of the measures of the angles in $\triangle ABC$?

5. Given the following figure:

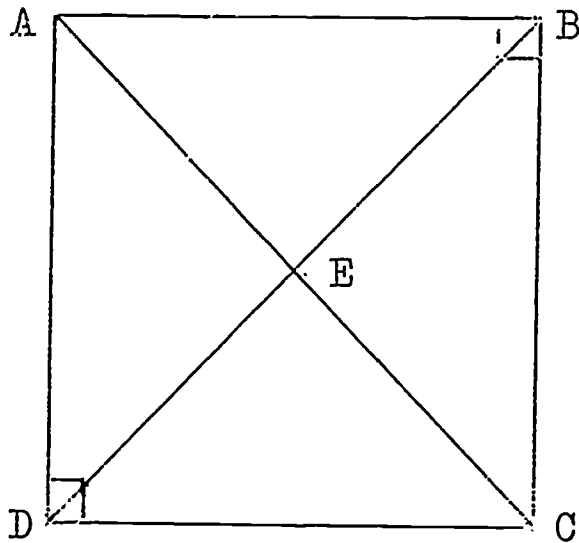

- a. $m \overline{AD} = ?$; $m \overline{DC} = ?$
 - b. What kind of triangle is $\triangle DAC$?
 - c. $m \overline{AB} = ?$; $m \overline{BC} = ?$
 - d. What kind of triangle is $\triangle ABC$?
 - e. $m \overline{AE} = ?$; $m \overline{DE} = ?$; $m \angle AED = ?$
 - f. What kind of triangle is $\triangle AED$?
 - g. What is $\{ \text{region of } \triangle ADC \} \cap \{ \text{region of } \triangle DBC \}$?
 - h. What is $\{ \text{region of } \triangle ADE \} \cup \{ \text{region of } \triangle DEC \}$?
6. Draw the following figure into your notebook from the directions given, then answer the questions asked:
- a. Draw a line segment CD 3 inches long.
 - b. Draw a ray CX such that $m \angle DCX = 60$.
 - c. Draw a ray DY such that $m \angle CDY = 30$.
 - d. Label the point of intersection of \overline{CX} and \overline{DY} point E.
 - e. What kind of triangle is $\triangle DEF$?
 - f. Check your answer in part (e) above by measuring $\angle CED$. What is this measure ?
 - g. What is the sum of the measures of the angles in $\triangle DEF$?

7. Draw the following figure into your notebook from the given directions, then answer the questions asked:
- Draw a line segment FG 2.5 inches long.
 - Draw ray FP such that $m\widehat{GFP} = 72$.
 - Draw ray GQ such that $m\angle FGQ = 72$.
 - Label the point of intersection of \overrightarrow{FP} and \overrightarrow{GQ} point H .
 - What kind of triangle do you think $\triangle GHF$ is?
 - Check your answer in part (e) above by measuring \overline{FH} and \overline{GH} . What is true of these measures?
 - $m\angle FHG = ?$
 - Add the three measures of the angles of $\triangle GHF$. What is the sum of these measures?
8. Given the following triangle ABC :

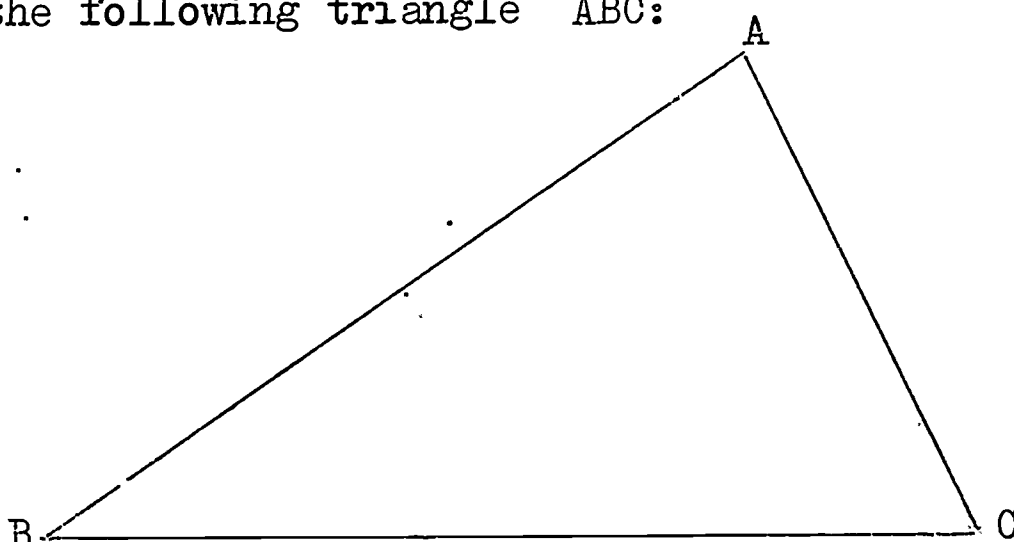

Answer these questions in your notebook:

- $m\overline{AB} = ?$; $m\overline{AC} = ?$; $m\overline{BC} = ?$
- $m\angle A = ?$; $m\angle B = ?$; $m\angle C = ?$
- Which side of $\triangle ABC$ has the greatest measure? Does the angle opposite that side also have the greatest measure?
- Which angle of $\triangle ABC$ has the least measure? Does the side opposite that angle also have the least measure?
- Draw any scalene $\triangle RST$ in your notebook. Do parts a, b, c and d using your triangle RST .

- f. Is your answer to part (d) above the same for $\triangle RST$ as it was for $\triangle ABC$?
- g. Try to draw a triangle in which the answer to part (d) is different. What do you conclude ?
- h. Do you think that in every triangle, the side opposite the smallest angle has the least measure ?

9. Given the following figure:

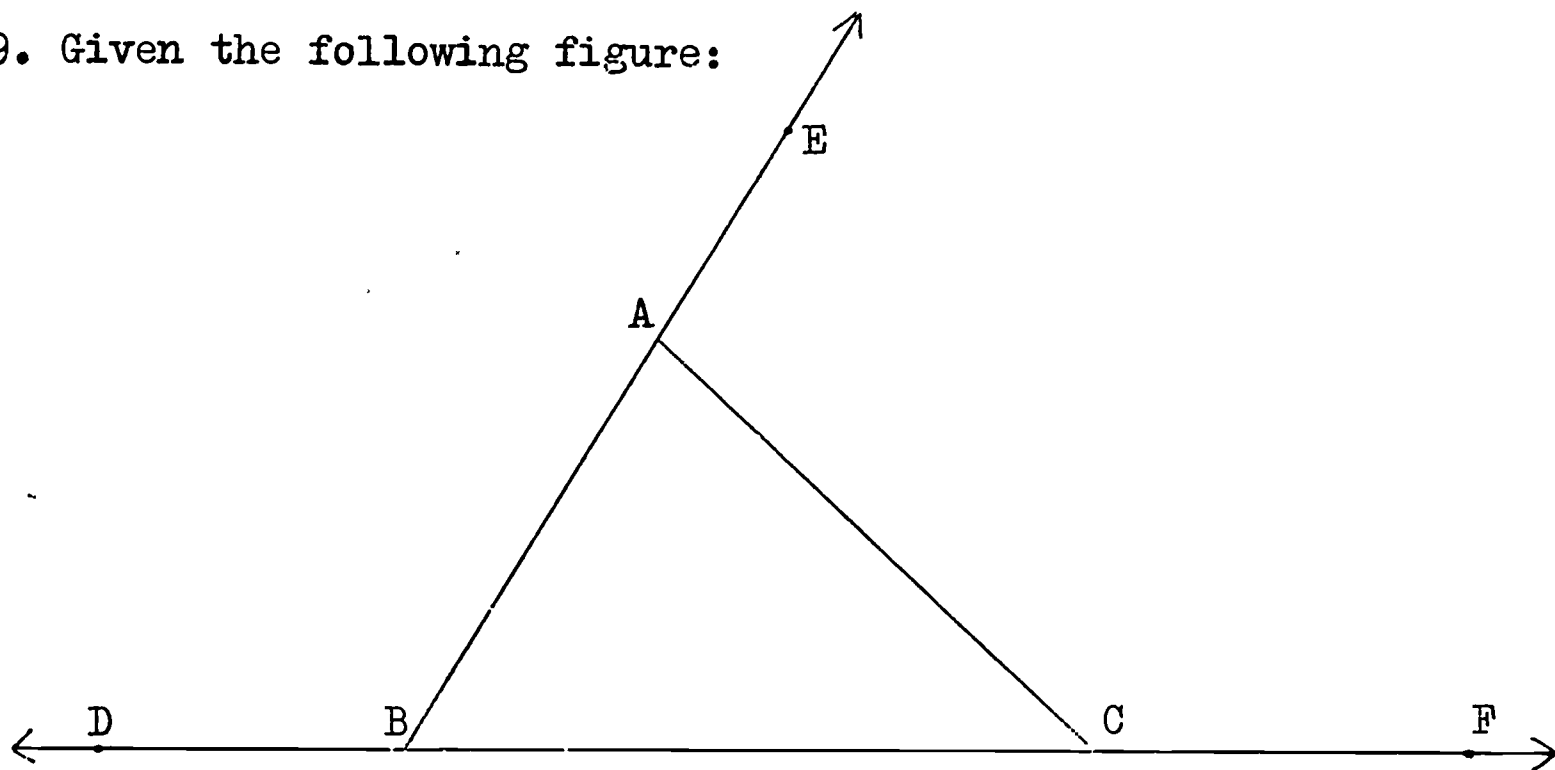

- a. $m \angle ABC = ?$; $m \angle BAC = ?$ What is the sum of these measures ?
- b. $\angle ACF$ is called an exterior angle of $\triangle ABC$. $m \angle ACF = ?$
- c. What do you notice about $m \widehat{ACF}$ and $(m \widehat{BAC} + m \widehat{ABC})$?
- d. $m \angle ACB = ?$; $(m \widehat{BAC} + m \widehat{ACB}) = ?$
- e. $\angle ABD$ is another exterior angle of $\triangle ABC$. $m \angle ABD = ?$
- f. What do you notice about $m \widehat{ABD}$ and $(m \widehat{BAC} + m \widehat{ACB})$?
- g. $\angle EAC$ is a third exterior angle of $\triangle ABC$. $m \angle EAC = ?$
- h. What do you notice about $m \widehat{EAC}$ and $(m \widehat{ABC} + m \widehat{ACB})$?
- i. Is the measure of an exterior angle of $\triangle ABC$ equal to the sum of the measures of the two opposite interior angles ?

10. In your notebook, answer " Always " if the sentence is always true. Answer " Never " if the sentence is never true. Answer " Sometimes " if the sentence is sometimes true and sometimes false:
- An equilateral triangle is also equiangular.
 - An isosceles triangle is also equilateral.
 - Scalene triangles are obtuse.
 - Acute triangles are isosceles.
 - Isosceles triangles are acute.
 - An acute triangle is scalene.
 - Isosceles triangles are obtuse.
 - Acute triangles are equiangular.
 - Isosceles triangles are scalene.
 - No acute triangle is a right triangle.
 - Obtuse triangles are scalene.
 - A right triangle is an acute triangle.
 - Obtuse triangles are isosceles.
 - No equilateral triangle is obtuse.
 - A scalene triangle is also acute.

2-6 Line Segments and Triangles

Look at line segment \overline{AB} in figure (1). Point X is called the midpoint of \overline{AB} because $m \overline{XB} = m \overline{XA}$. Use your ruler to check that these measures are equal.

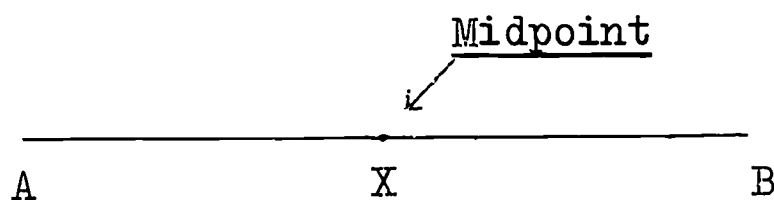

$$m \overline{AX} = m \overline{XB}$$

(1)

Now look at $\angle RST$ in figure (2). \overrightarrow{SV} is said to bisect $\angle RST$ because $m\angle RSV = m\angle VST$. Use your protractor to check that these measures are equal.

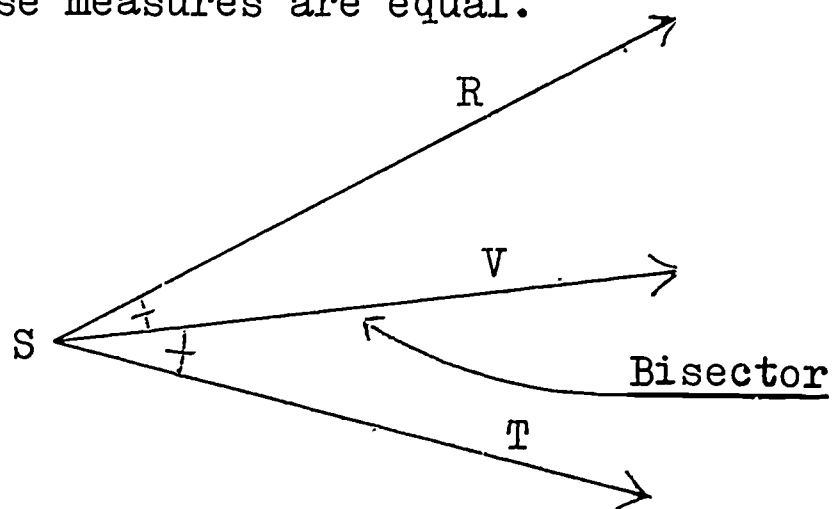

(2)

In figure (3), point P is the midpoint of \overline{XZ} . The line segment PY is called a median of triangle XYZ.

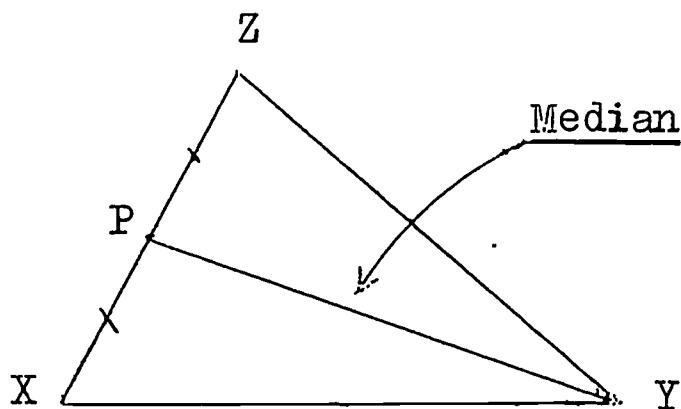

(3)

There is another median from vertex Z to the midpoint of \overline{XY} , and a third median from X to the midpoint of \overline{ZY} . How many medians does a triangle have? Do the medians of $\triangle XYZ$ lie inside the triangle?

In triangle ABC of figure (4), \overline{BZ} is the bisector of angle B because $m\angle CBZ = m\angle ZBA$.

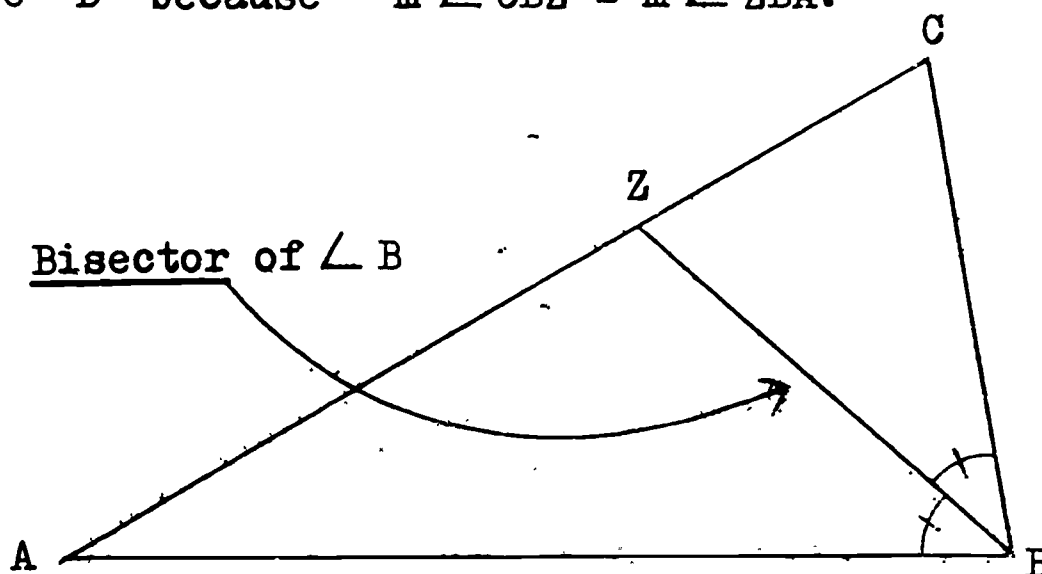

(4)

Do you think that \overline{BZ} is also a median of $\triangle ABC$? Measure \overline{AZ} and \overline{CZ} to check your answer.

There is also an angle bisector for $\angle C$ and one for $\angle A$. Copy $\triangle ABC$ into your notebook. Then use your protractor to help you draw the bisectors of angles A and C. Do the angle bisectors in your figure lie inside the triangle ABC?

Now look at figure (5). \overline{TK} and \overline{YL} are altitudes of the triangles.

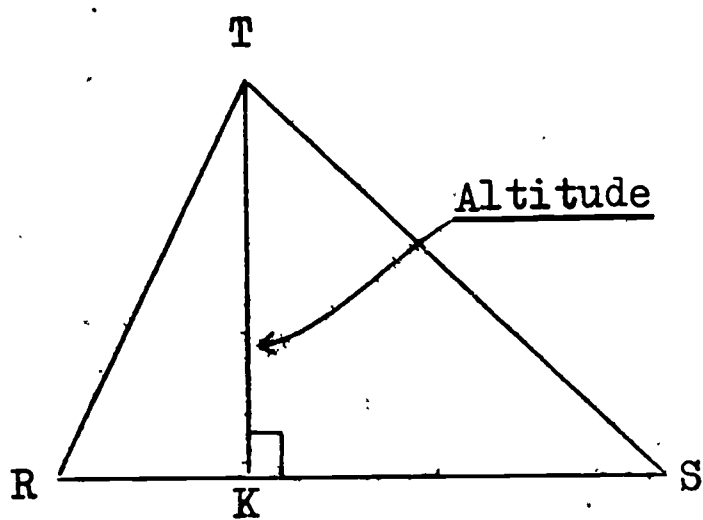

(a)

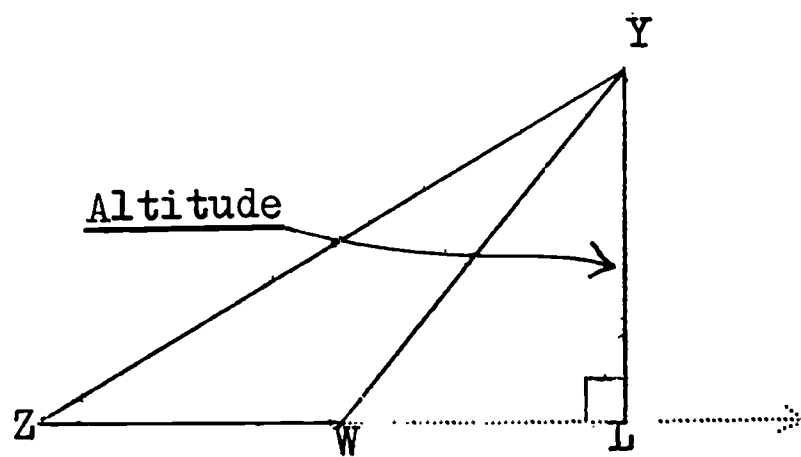

(b)

(5)

An altitude of a triangle is a line segment drawn from a vertex perpendicular to the line which contains the opposite side. An altitude forms a right angle with the line containing the side to which it is drawn.

Notice in figure (5b) that \overline{ZW} was extended so that $\overline{YL} \perp \overline{ZW}$ at L.

Will the altitudes in (5a) lie inside the triangle? Will two altitudes in (5b) lie outside the triangle? Can an altitude of a triangle also be a side of the triangle?

Exercises 2-6

1. Given the following figure:

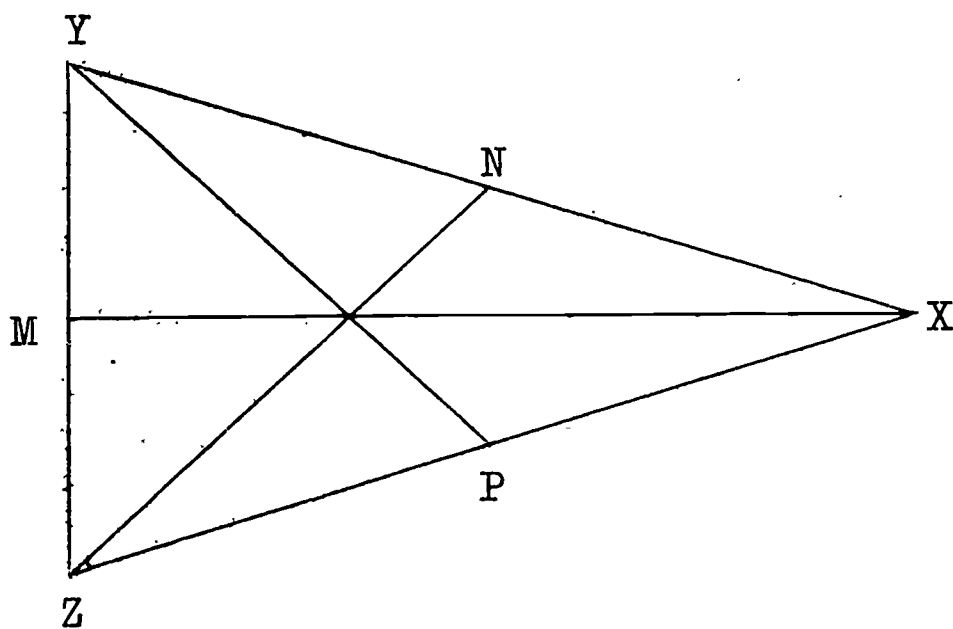

- $m \overline{XY} = ?$; $m \overline{XZ} = ?$; What kind of triangle is $\triangle XYZ$?
- Is N the midpoint of \overline{XY} ? Is P the midpoint of \overline{XZ} ?
 \overline{YP} and \overline{ZN} are called _____ of $\triangle XYZ$.
- $m \angle YXM = ?$; $m \angle ZXM = ?$; $m \overline{YM} = ?$; $m \overline{ZM} = ?$ \overline{XM} is called a _____ of $\triangle XYZ$. \overline{XM} is also an _____ of $\triangle XYZ$.
- $m \overline{YP} = ?$; $m \overline{ZN} = ?$; What is true of these measures ?
- $\triangle NZY \cap \triangle PZY = ?$
- Is $m \angle YXP = m \angle ZZN$? ; Is $\angle YXP = \angle ZZN$?
- Is $m \angle XYP = m \angle XZN$? ; Is $\angle XYP = \angle XZN$?

2. Draw the following figure in your notebook from the directions given, then answer the questions asked:
- Draw a line segment \overline{AB} 3 inches long.
 - Draw \overrightarrow{AP} so that $m\angle BAP = 60$.
 - Draw \overrightarrow{BQ} so that $m\angle ABQ = 60$.
 - Label the point of intersection of \overrightarrow{AP} and \overrightarrow{BQ} point C.
 - What kind of triangle is $\triangle ABC$? Measure $\angle ACB$ to check.
 - With your ruler, mark the midpoint of \overline{AB} , and call that point M. Also mark the midpoint N of \overline{BC} , and the midpoint R of \overline{AC} .
 - Draw \overline{AN} , \overline{BR} , and \overline{CM} . What do you notice about these three segments?
 - $m\angle BAN = ?$; $m\angle CAN = ?$; What is another name for \overline{AN} ? for \overline{CM} ? for \overline{BR} ?
 - In what special triangle are the medians and the angle bisectors the same line segments?
3. Given the triangle ABC:

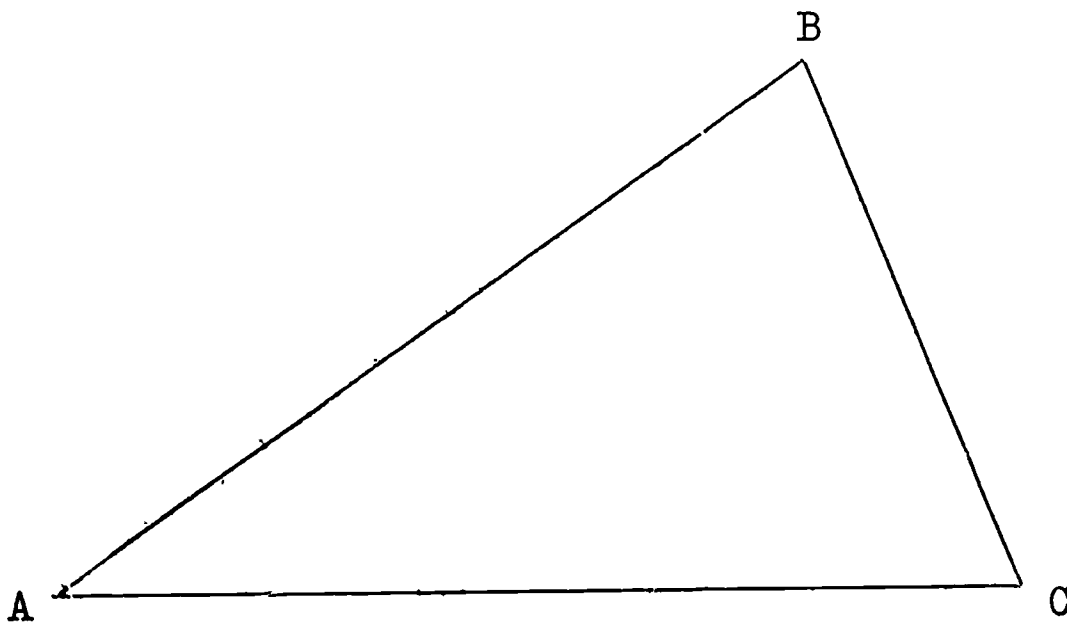

- Copy $\triangle ABC$ into your notebook.
- With your ruler, carefully find the midpoints of the three sides of $\triangle ABC$, and draw the three medians.
- What do you notice about the three medians?

d. With your protractor, carefully draw the three angle bisectors of $\triangle ABC$.

e. What do you notice about these three angle bisectors?

4. Given the triangle DEF:

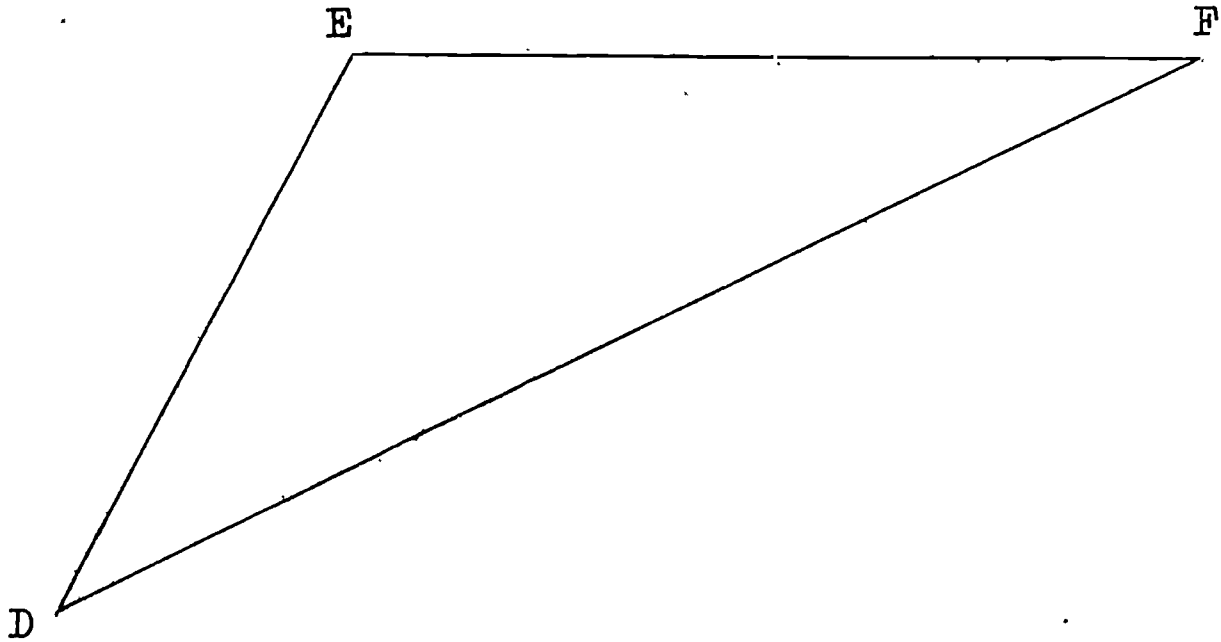

a. Copy $\triangle DEF$ into your notebook, and follow the directions of 3b to 3e above.

f. Are your answers in 3c and 4c the same?

g. Are your answers in 3e and 4e the same?

5. Given the following triangle GHI:

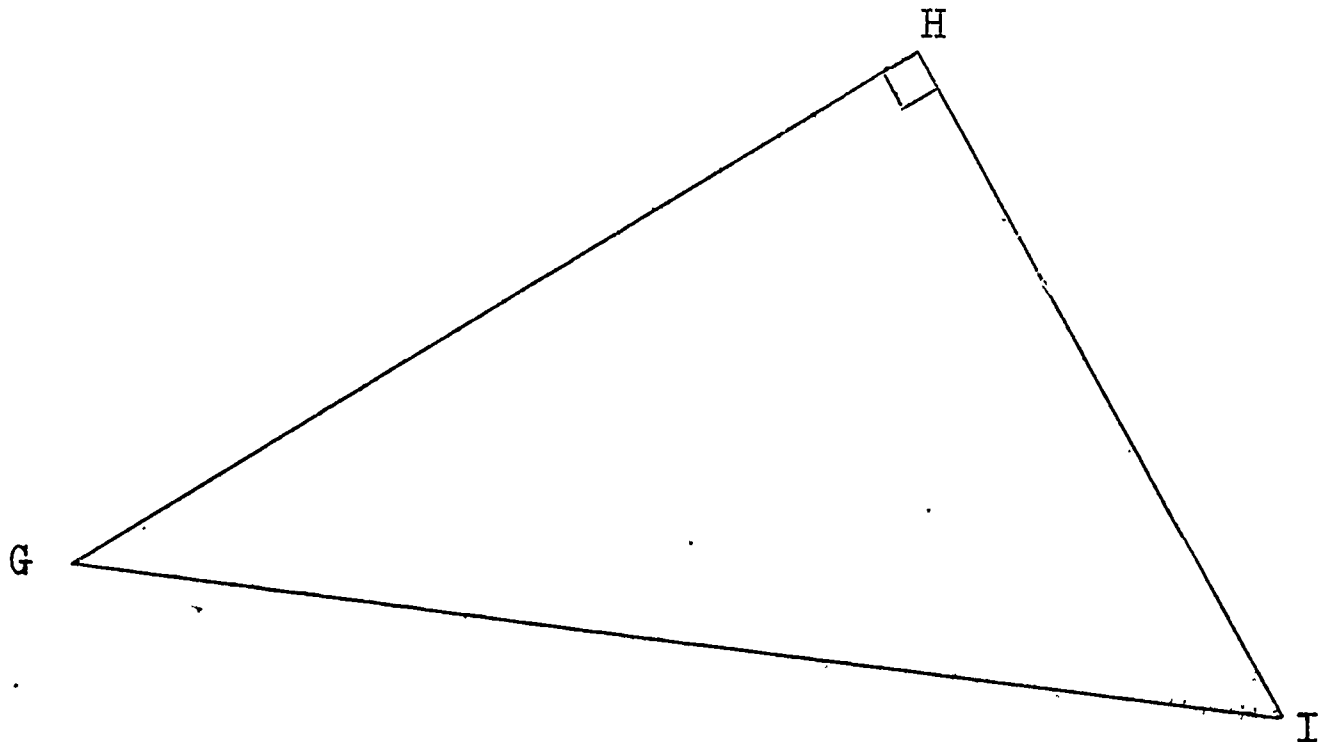

- a. Copy $\triangle GHI$ into your notebook, and follow the directions of 3b to 3e above.
- f. Are your answers in 3c, 4c, and 5c the same ?
- g. Are your answers in 3e, 4e, and 5e the same ?
6. a. Copy $\triangle ABC$ of Exercise 3 above into your notebook again.
- b. Use your set squares to help you draw the three altitudes of $\triangle ABC$.
- c. What do you notice about the three altitudes ?
- d. Where do the three altitudes intersect ?
7. a. Copy $\triangle DEF$ of Exercise 4 above into your notebook again, and follow the directions of 6b to 6d above. Must you extend sides \overline{FE} and \overline{DE} ?
- e. Are your answers in 6c and 7c the same ?
- f. Are your answers in 6d and 7d the same ?
8. a. Copy $\triangle GHI$ of Exercise 5 above into your notebook again, and follow the directions of 6b to 6d above. What line segments are two of the altitudes ?
- e. Are your answers in 6c, 7c, and 8c the same ?
- f. Are your answers in 6d, 7d, and 8d the same ?

2-7 More About Parallel Lines

Look at this picture of \overleftrightarrow{AB} and \overleftrightarrow{CD} intersected by \overleftrightarrow{EF} :

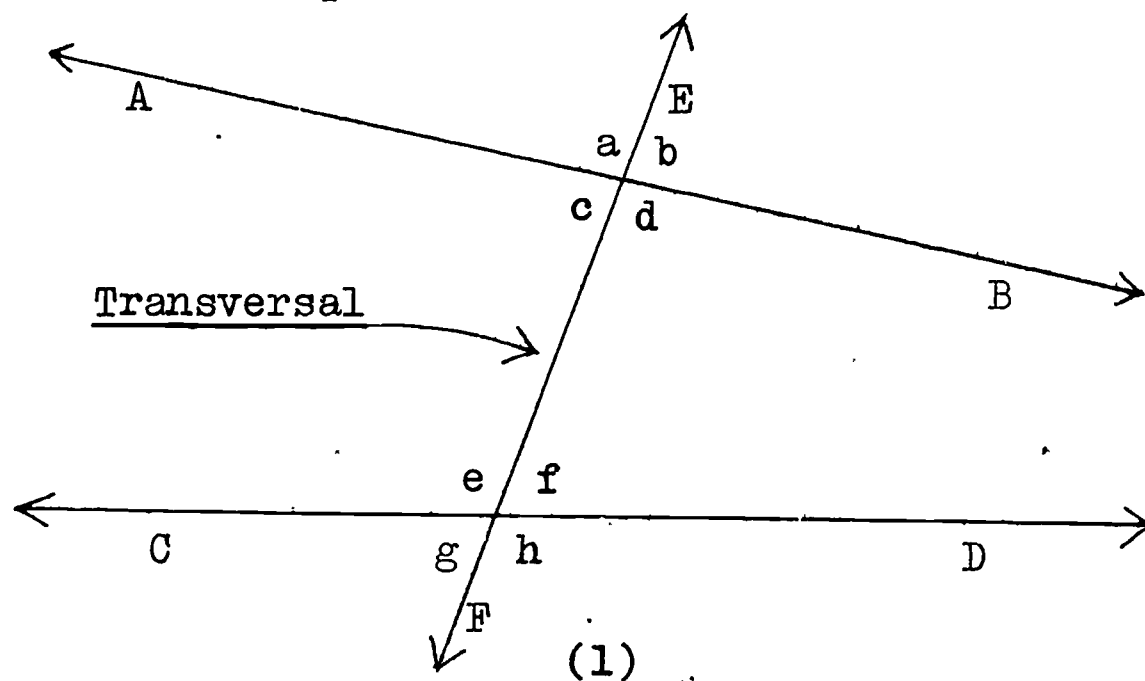

In figure (1), \overleftrightarrow{EF} is called a transversal.

Angles c and e , d and f are called interior angles.

Angles a and g , b and h are called exterior angles.

Angles d and h , a and e , b and f , c and g are called corresponding angles.

Angles c and f are called alternate angles. Angles d and e are also alternate angles.

In figure (2), \overleftrightarrow{RS} and \overleftrightarrow{TV} are parallel. \overleftrightarrow{XY} is a transversal.

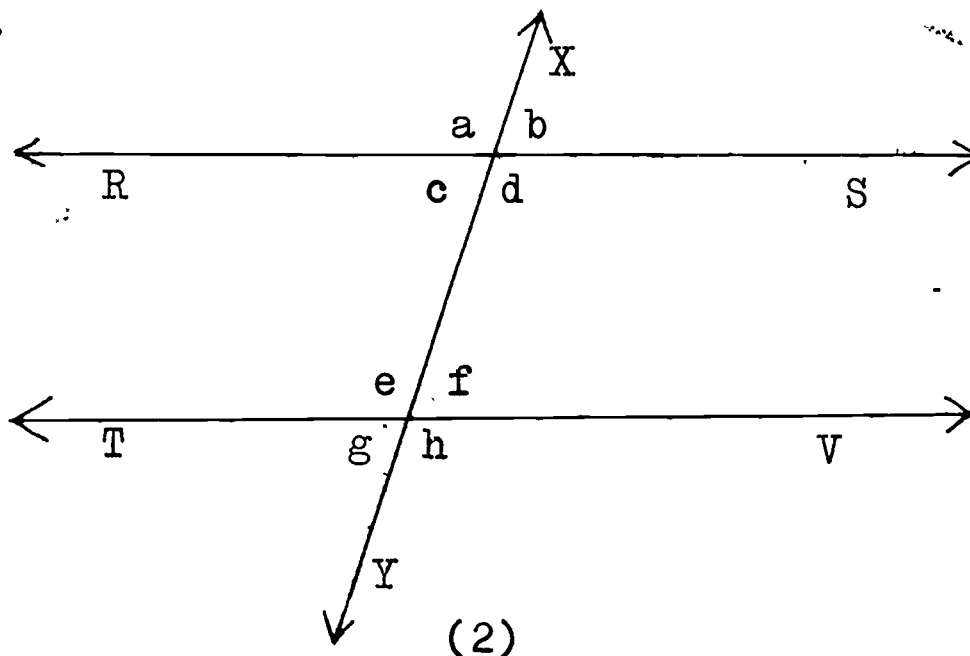

Use your protractor to measure all of the angles in figure (2), and record your measures in your notebook.

$$m \angle a = ? ; m \angle b = ? ; m \angle c = ? ; m \angle d = ? ; m \angle e = ?$$

$$m \angle f = ? ; m \angle g = ? .$$

If you measured accurately, you should have found that:

$$m \angle a = m \angle d = m \angle e = m \angle h$$

$$\text{and } m \angle b = m \angle c = m \angle f = m \angle g .$$

Angles c and f are alternate interior angles. What is true of their measures? Is this true of the other pair of alternate interior angles?

Angles c and g are corresponding angles. What is true of their measures? Angles d and h are also corresponding angles. What is true of $m \angle d$ and $m \angle h$? Is this also true for the measures of all other pairs of corresponding angles?

What are two angles called if the sum of their measures is 180 ? $(m \angle d + m \angle f) = ?$ What are angles d and f called? $(m \angle c + m \angle e) = ?$ What are angles c and e called? What is true of two interior angles on the same side of the transversal?

When two parallel lines are intersected by a transversal,

- (1) Alternate angles have equal measures.
- (2) Corresponding angles have equal measures.
- (3) Interior angles on the same side of the transversal are supplementary.

Exercises 2-7

1. Given the following figure:

Name two pairs of:

- corresponding angles.
- alternate interior angles.
- interior angles on the same side of the transversal.
- alternate exterior angles.

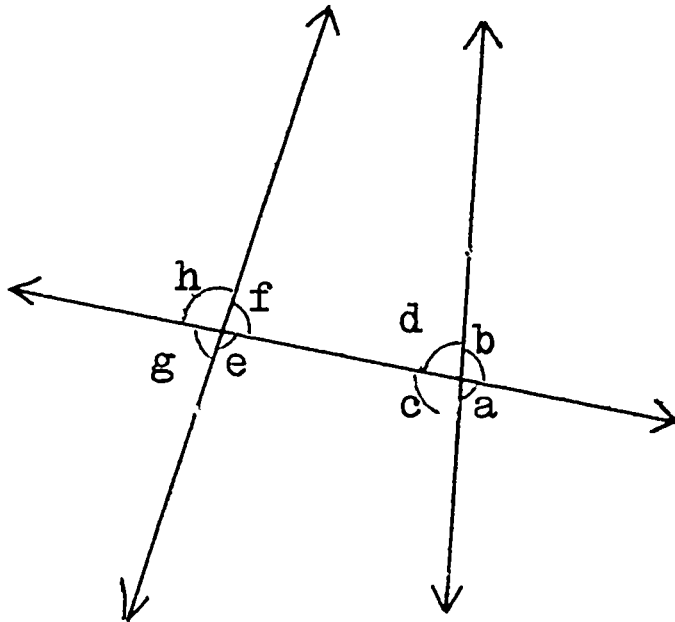

2. Given the figure in which $\overleftrightarrow{WY} \parallel \overleftrightarrow{VZ}$ and $m\angle d = 110$. Find the measure of all other angles.

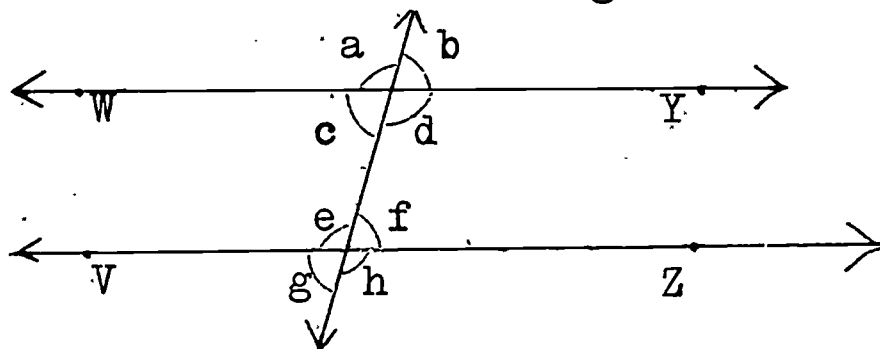

3. In the figure, \overleftrightarrow{AB} is not parallel to \overleftrightarrow{CD} .

Is $m\angle a = m\angle b$? Why? Check your answer by measuring the angles with your protractor.

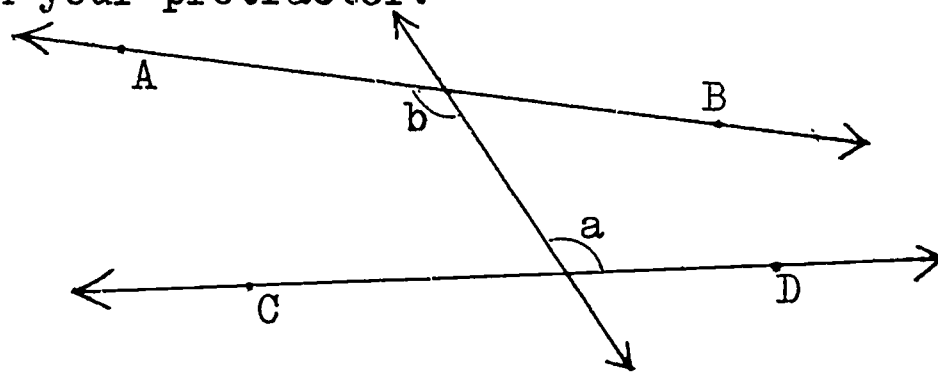

4. Given the figure in which $m\hat{x} > m\hat{y}$

- Do you think \overleftrightarrow{AB} and \overleftrightarrow{CD} will intersect? Why?
- On which side of \overleftrightarrow{EF} do you think \overleftrightarrow{AB} and \overleftrightarrow{CD} will intersect? Why?

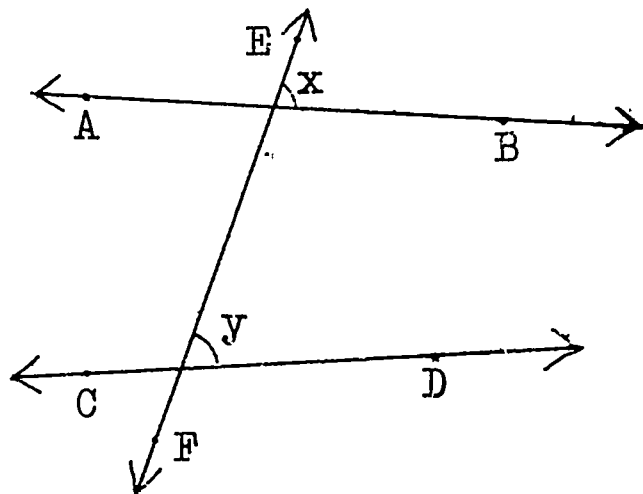

5. Given the figure in which $m\hat{a} > m\hat{b}$.

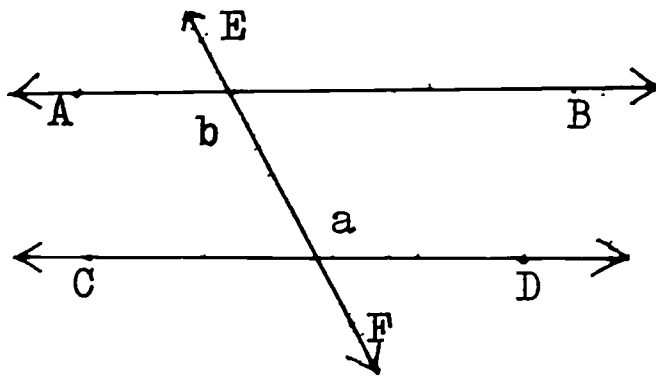

a. On which side of \overleftrightarrow{EF} will \overleftrightarrow{AB} and \overleftrightarrow{CD} meet? Why?

6. Given $L \parallel m$ and $p \parallel q$.

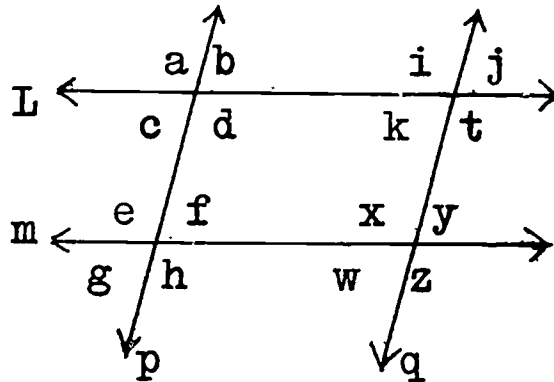

Without measuring, write as many pairs of supplementary angles as you can.

7. Given $\overleftrightarrow{CD} \perp \overleftrightarrow{EF}$, and $\overleftrightarrow{AB} \parallel \overleftrightarrow{CD}$.

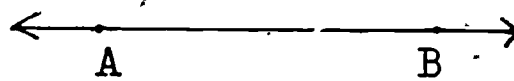

a. Will \overleftrightarrow{EF} intersect \overleftrightarrow{AB} ? Why?

b. What can you say about \overleftrightarrow{AB} and \overleftrightarrow{EF} ?

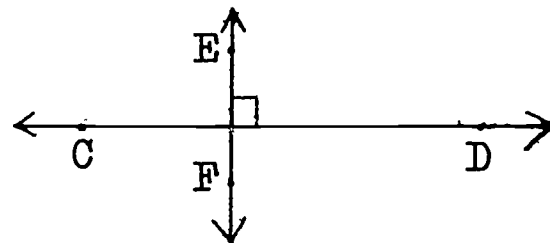

8. Given $L \parallel m \parallel n$ and $p \parallel q$.

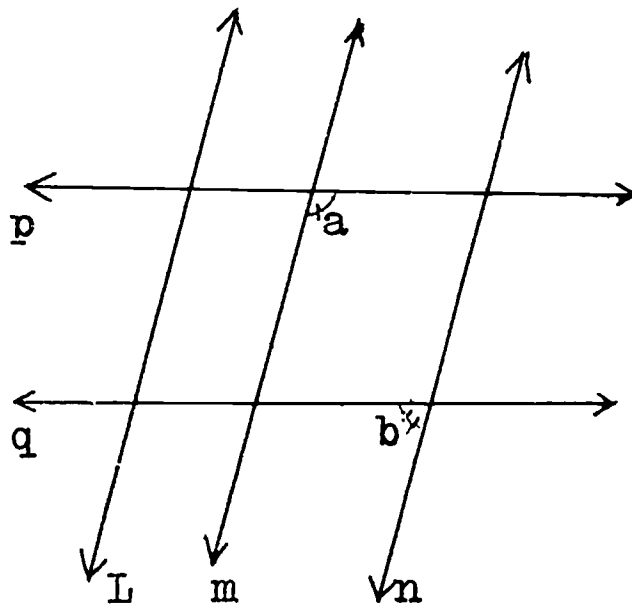

a. Copy the figure into your notebook.

b. On your figure, mark with one mark (\sphericalangle) those angles whose measures are the same as $m\angle a$.

c. Mark with two marks (\sphericalangle) those angles whose measures are the same as $m\angle b$.

9. Given the following figure in which $\overline{AB} \parallel \overline{CD}$ and $\overline{AD} \parallel \overline{BC}$:

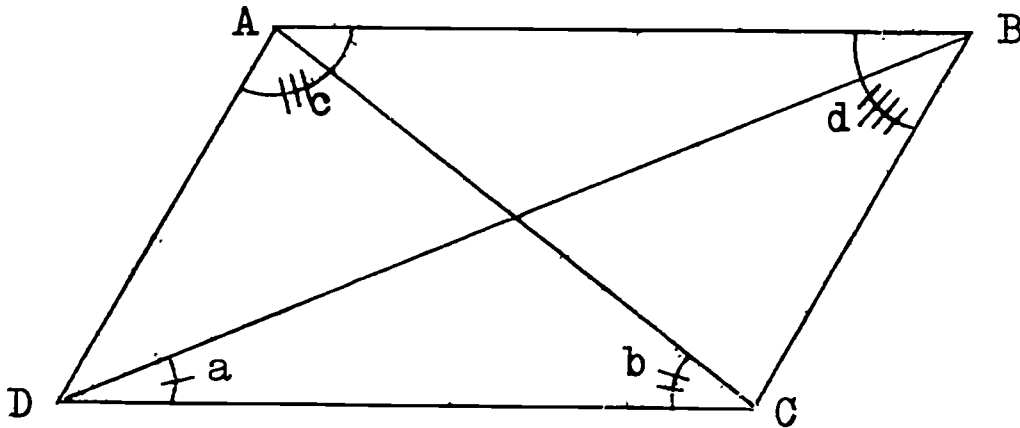

Copy the figure into your notebook. Then, without measuring, mark with:

- one mark all those angles whose measures are the same as $m \angle a$.
- two marks all those angles whose measures are the same as $m \angle b$.
- three marks all those angles whose measures are the same as $m \angle c$.
- four marks all those angles whose measures are the same as $m \angle d$.

10. Given the following figure:

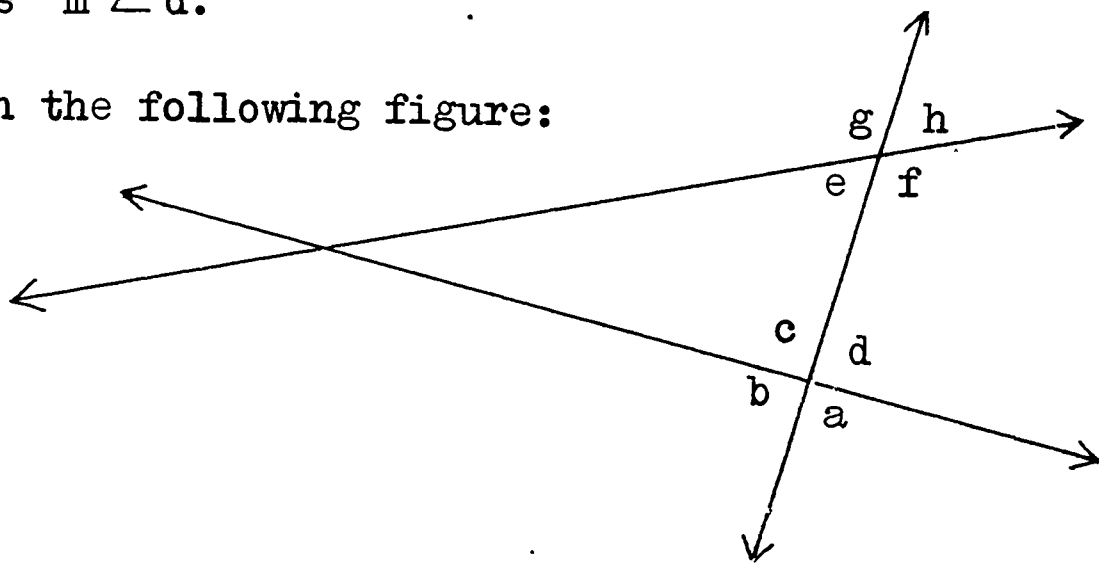

Write $>$, $<$, or $=$ in order to make each of the following true:

- $m \hat{a}$ _____ $m \hat{g}$
- $m \hat{b}$ _____ $m \hat{f}$
- $m \hat{c}$ _____ $m \hat{e}$
- $m \hat{a}$ _____ $m \hat{c}$
- $m \hat{c}$ _____ $m \hat{f}$

- $m \hat{a}$ _____ $m \hat{h}$
- $m \hat{b}$ _____ $m \hat{d}$
- $m \hat{d}$ _____ $m \hat{f}$
- $m \hat{c}$ _____ $m \hat{g}$
- $m \hat{e}$ _____ $m \hat{f}$

2-8 Quadrilaterals

A polygon with exactly four sides is called a quadrilateral. Here are pictures of some quadrilaterals:

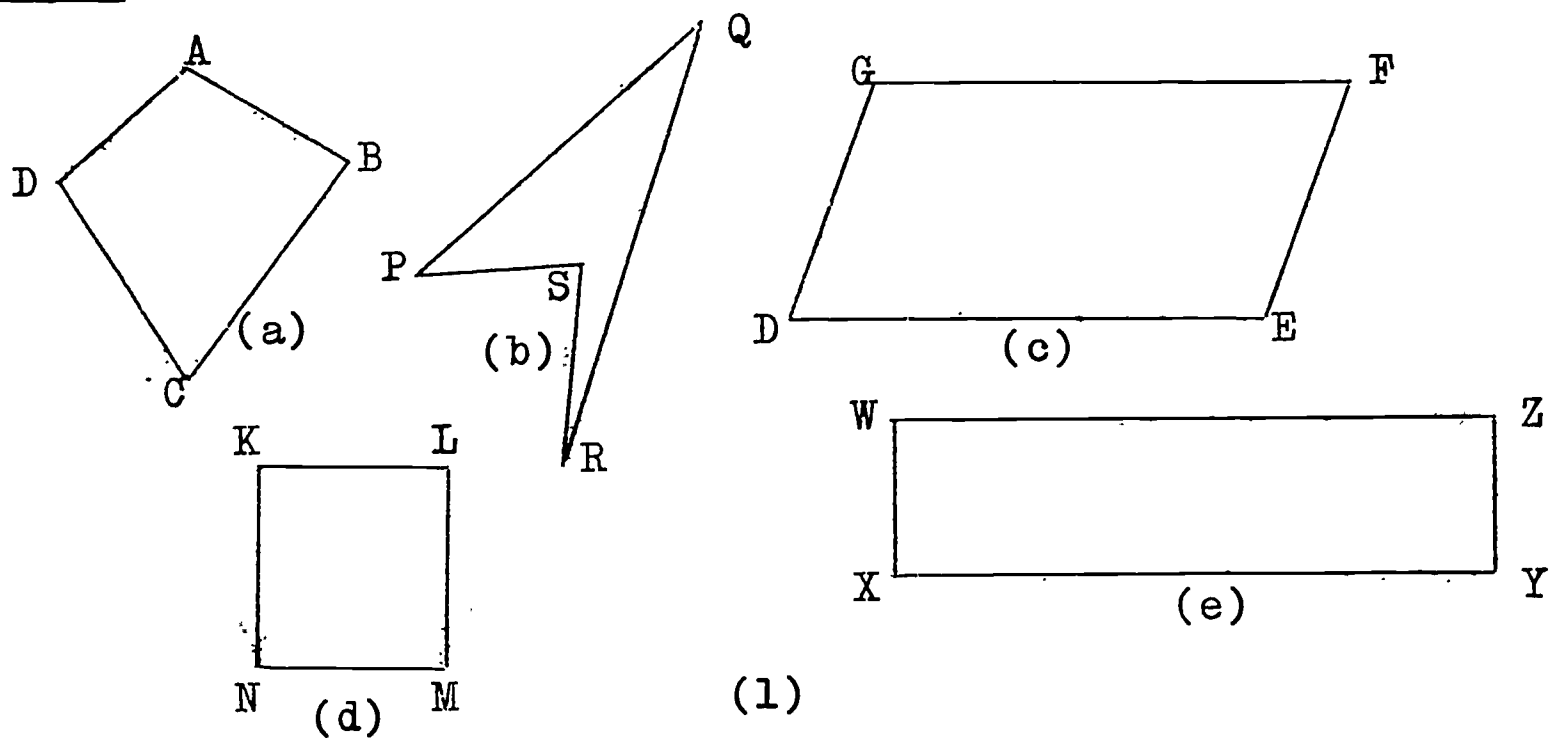

A quadrilateral with one pair of opposite sides parallel is called a trapezium. Here are pictures of some trapeziums:

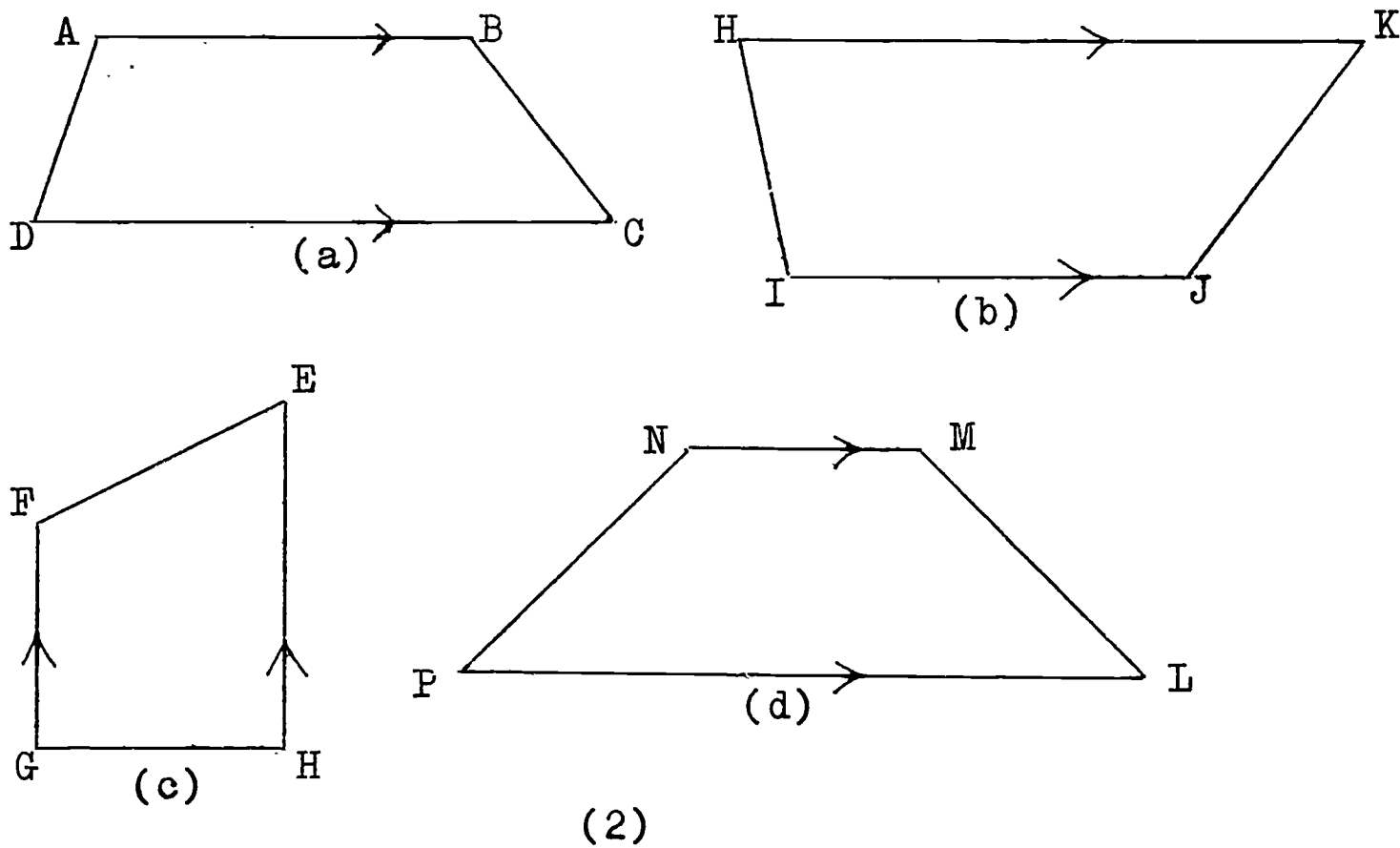

In ABCD of figure (2a), think of \overline{AD} as a transversal between the parallel sides \overline{AB} and \overline{CD} . What should be true of $\angle A$ and $\angle D$? Measure the angles to check your answer. What should be true of $\angle B$ and $\angle C$? Why?

In trapezium LMNP of figure (2d), $m\overline{NP} = m\overline{ML}$. LMNP is a special trapezium. LMNP is called an isosceles trapezium because $m\overline{NP} = m\overline{ML}$.

A quadrilateral with two pairs of parallel sides is called a parallelogram. Here are pictures of some parallelograms:

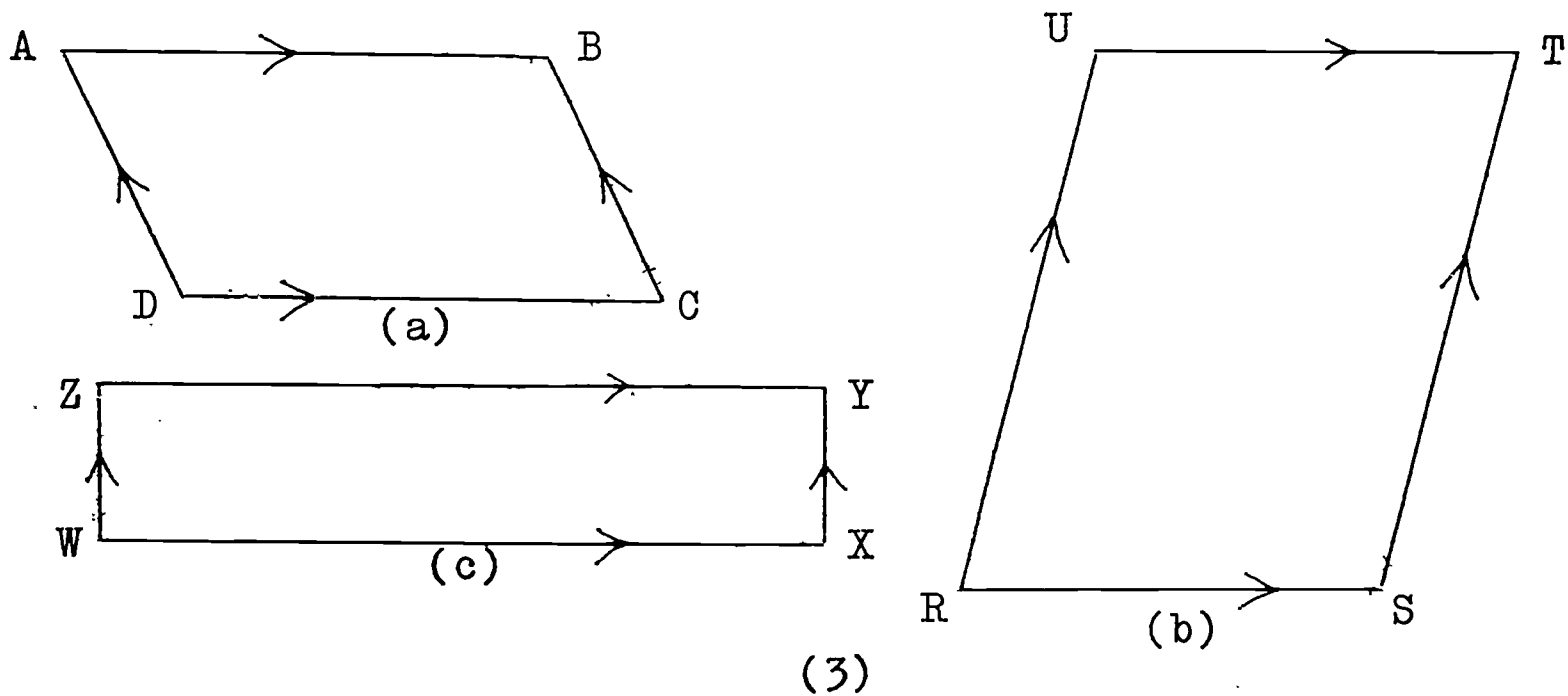

In figure (3a), measure \overline{AB} , \overline{BC} , \overline{CD} , and \overline{DA} . What do you notice about $m\overline{AB}$ and $m\overline{DC}$? About $m\overline{DA}$ and $m\overline{BC}$? Measure the opposite sides of RSTU and WXYZ. What do you observe? Do you think that the measures of the opposite sides of any parallelogram are equal? Try to draw a parallelogram in which the opposite sides do not have the same measure. What do you conclude?

Notice the symbol (\longrightarrow) indicating that the line segments are parallel in figures (2) and (3) above.

Now look at parallelogram RSTU in figure (3b).
Consider \overline{RS} to be a transversal cutting parallels \overline{ST} and \overline{RU} .

We have: $m \angle S + m \angle R = ?$; Why ?

Consider \overline{RU} to be a transversal cutting parallels \overline{RS} and \overline{TU} .

We have: $m \angle U + m \angle R = ?$; Why ?

Hence, $m \angle S + m \angle R = m \angle U + m \angle R$; Why ?

Therefore, $m \angle S = m \angle U$; Why ?

Now you set up a similar argument to show that:

$$m \angle R = m \angle T .$$

You have just shown that the opposite angles of a parallelogram have equal measure.

$\angle R$ and $\angle S$ in parallelogram RSTU of figure (3b) are called consecutive angles. $\angle R$ and $\angle S$ are supplementary angles. Why ? Consecutive angles of a parallelogram are supplementary.

In a parallelogram:

- (1) Opposite sides are parallel.
- (2) Opposite sides have equal measures.
- (3) Opposite angles have equal measures.
- (4) Consecutive angles are supplementary.

Notice that a parallelogram has two pairs of sides parallel, whereas a trapezium has one pair of opposite sides parallel. Hence, a parallelogram is a special kind of trapezium. Is every trapezium a parallelogram ? Is every parallelogram a trapezium ?

Exercises 2-8

1. Write two different names for each of the following quadrilaterals:

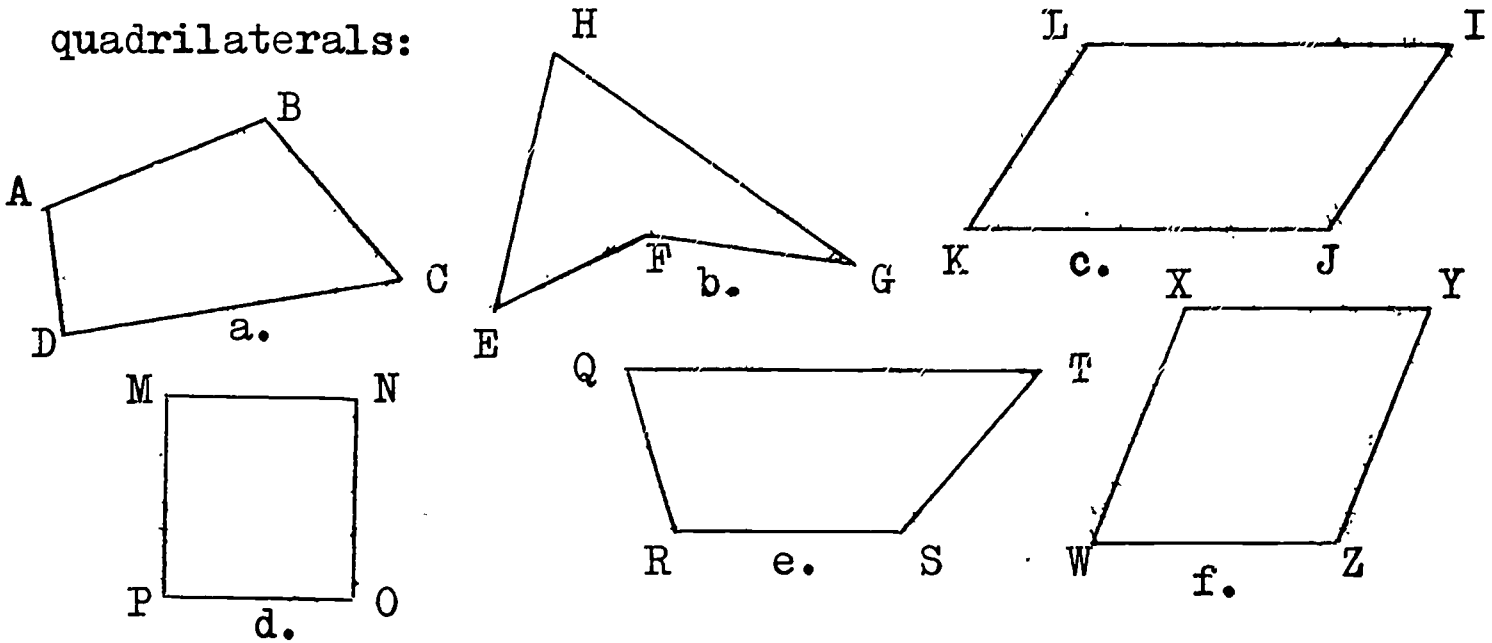

2. Given the following quadrilateral in which $\overline{AB} \parallel \overline{CD}$:

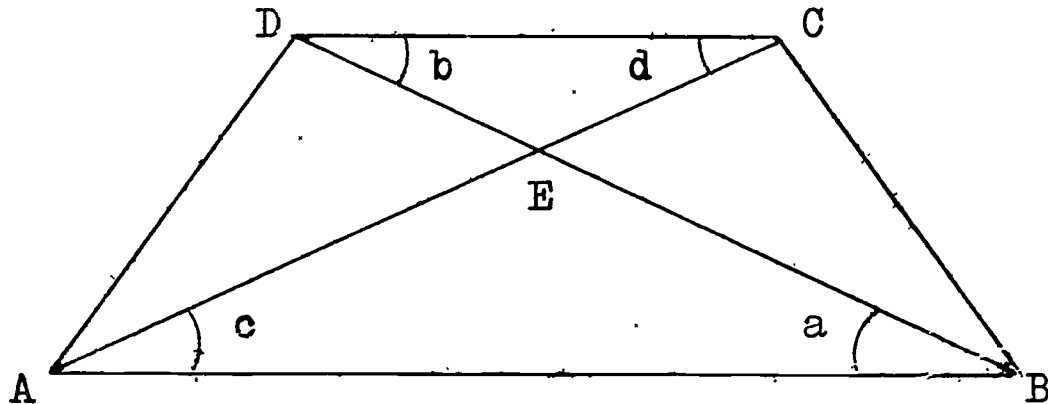

- a. $m \overline{AD} = ?$; $m \overline{BC} = ?$; What is true of these measures ?
- b. What kind of quadrilateral is ABCD ?
- c. $m \overline{AC} = ?$; $m \overline{DB} = ?$; What is true of these measures ?
- d. $m \angle a = ?$; $m \angle b = ?$; What is true of these measures ?
- e. $m \angle c = ?$; $m \angle d = ?$; What is true of these measures ?
- f. What is true of $m \angle a$ and $m \angle c$?
- g. $m \overline{AE} = ?$; $m \overline{BE} = ?$; What kind of triangle is $\triangle AEB$?
- h. $m \overline{DE} = ?$; $m \overline{CE} = ?$; What kind of triangle is $\triangle DEC$?
- i. $\triangle ADB \cap \triangle ACB = ?$
- j. $\triangle ADC \cap \triangle BDC = ?$

3. Given the quadrilateral in which $\overline{AB} \parallel \overline{CD}$ and $\overline{AD} \parallel \overline{BC}$:

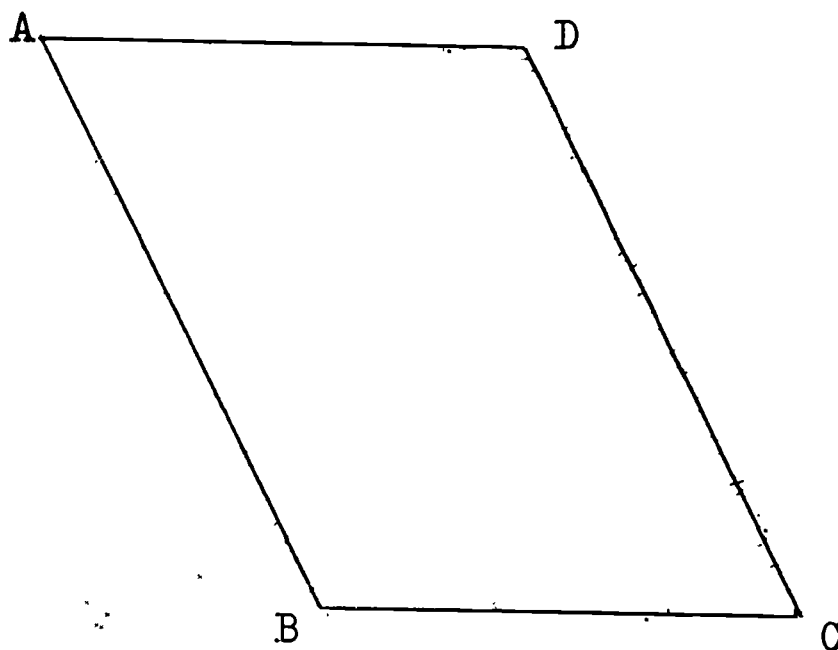

- $m \widehat{AD} = ?$; $m \widehat{BC} = ?$; What is true of these measures ?
What are these sides called ?
 - $m \widehat{AB} = ?$; $m \widehat{CD} = ?$; What is true of these measures ?
What are these sides called ?
 - $m \angle A = ?$; $m \angle D = ?$; What is the sum of these measures ?
What are these angles called ?
 - $m \angle B = ?$; $m \angle C = ?$; What is true of these measures ?
What are these angles called ?
 - What name do we give quadrilateral ABCD ?
4. Each of the following figures is a parallelogram. Find $m \angle x$, $m \angle y$, and $m \angle z$ in each figure:

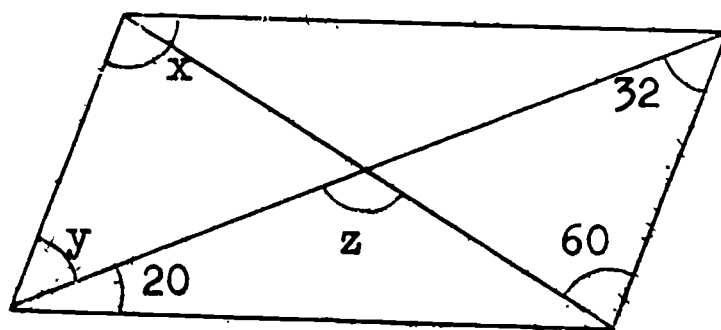
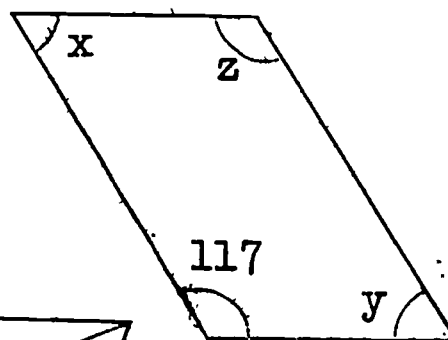
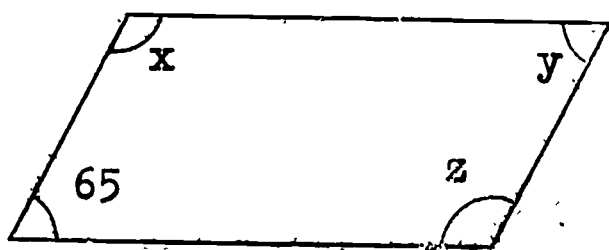

5. Given the parallelogram PQRS in which the diagonals intersect at T :

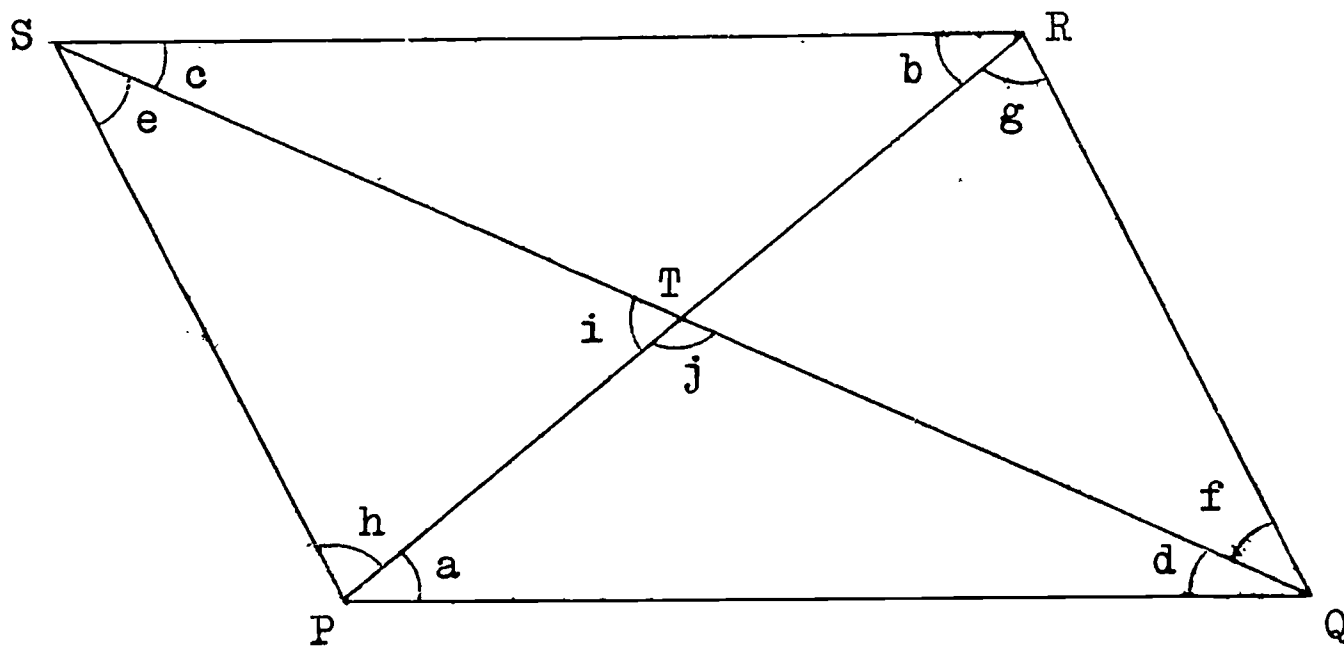

- Will $m \angle a = m \angle b$? Why ? Check your answer by measuring the angles.
 - Will $m \angle c = m \angle d$? Why ? Measure the angles to check your answer.
 - Will $m \angle e = m \angle f$? Why ? What are these angles called ?
 - Is $m \angle g = m \angle h$? Why ? What are these angles called ?
 - Is $(m \angle a + m \angle h) = (m \angle b + m \angle g)$? Why ?
 - Is $(m \angle c + m \angle e) = (m \angle d + m \angle f)$? Why ?
 - $(m \angle SPQ + m \angle PSR) = ?$ What are these angles called ?
 - $(m \angle SPQ + m \angle PQR) = ?$ What are these angles called ?
 - Is $m \angle i = m \angle j$? What are these angles called ?
6. Refer to the parallelogram PQRS in Exercise 5 above.
- $m \overline{ST} = ?$; $m \overline{TQ} = ?$; What is true of these measures ?
 - $m \overline{PT} = ?$; $m \overline{TR} = ?$; What is true of these measures ?
 - Point T is the _____ of \overline{SQ} . Point T is the _____ of \overline{PR} .

2-9 Special Parallelograms

A parallelogram with two adjacent sides of equal measure is a rhombus. Here are pictures of some rhombuses:

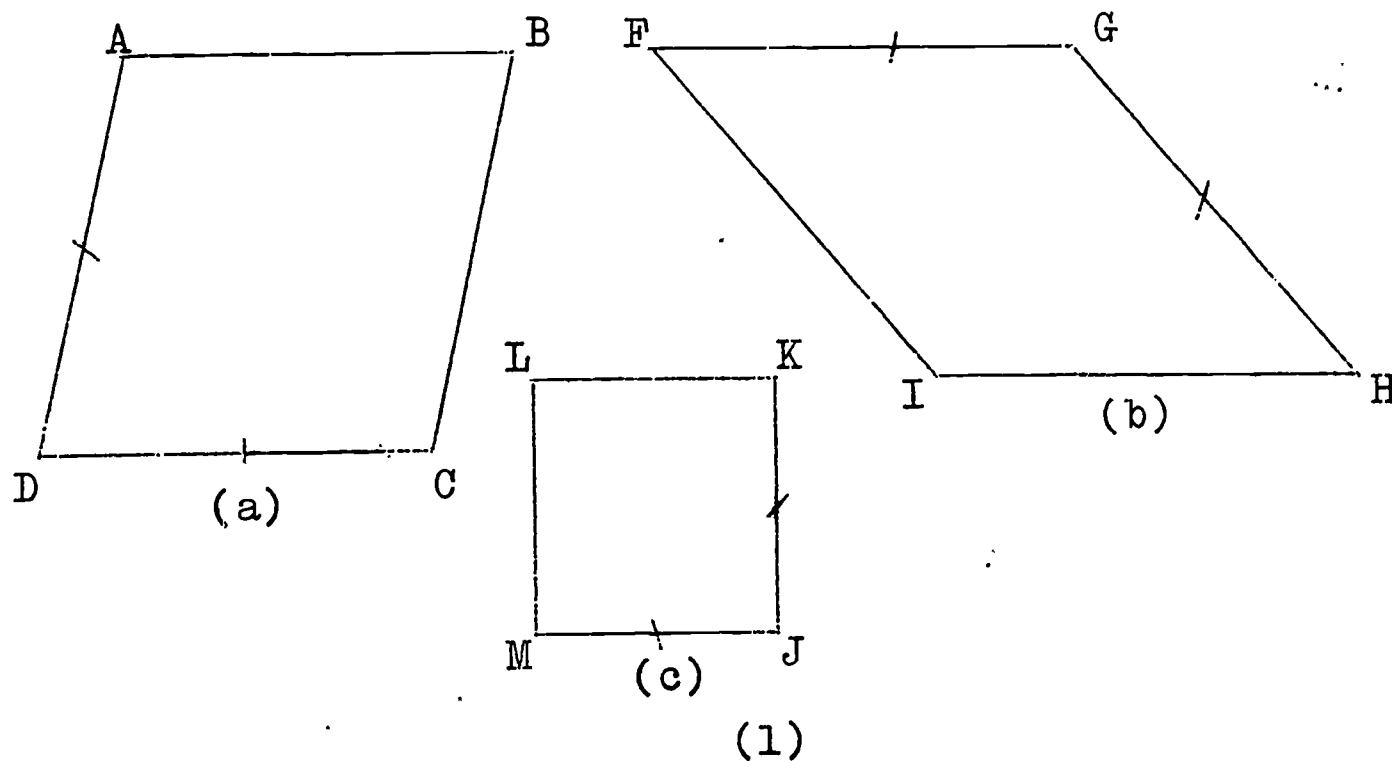

In figure (1a), $ABCD$ is a rhombus. Therefore, $ABCD$ is a parallelogram. Why? What property of parallelograms tells us that:

$$m \overline{AB} = m \overline{DC}$$

and $m \overline{DA} = m \overline{BC}$?

But: $m \overline{DA} = m \overline{DC}$ Why ?

Therefore, $m \overline{AB} = m \overline{BC} = m \overline{CD} = m \overline{DA}$.

Can you give a similar argument for rhombus (1b) to show that:

$$m \overline{FG} = m \overline{GH} = m \overline{HE} = m \overline{EF} ?$$

What can you conclude about all sides of any rhombus ?

A parallelogram with one right angle is a rectangle.

Here are pictures of some rectangles:

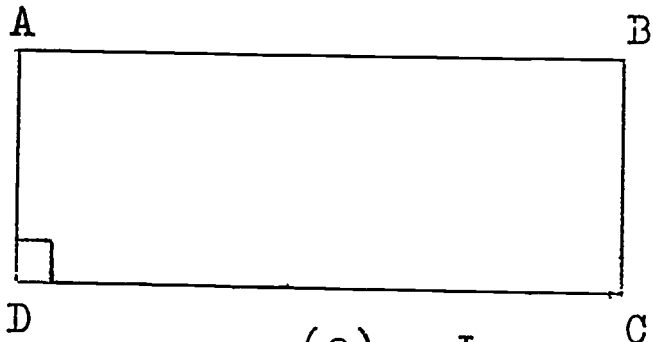

(a)

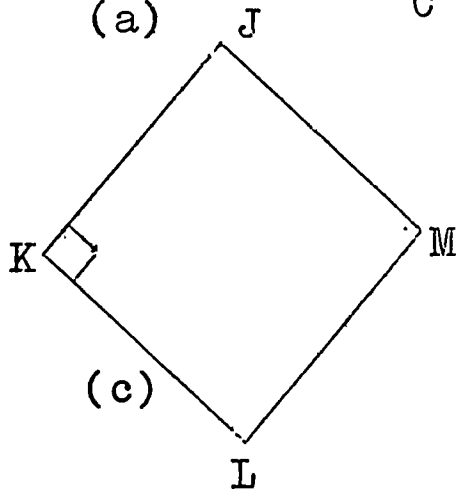

(c)

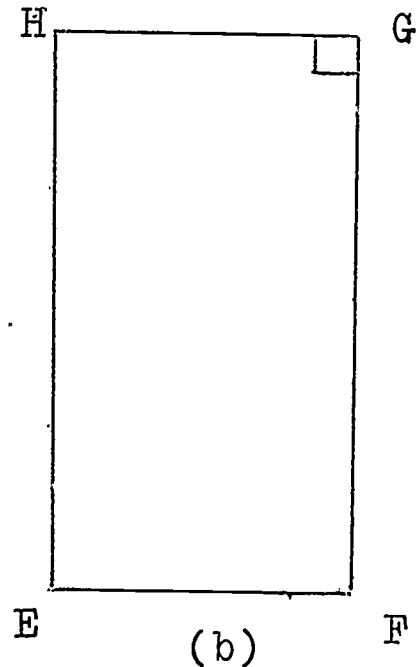

(b)

(2)

In figure (2a), rectangle ABCD is also a parallelogram. Why? What property of parallelograms tells us that:

$\angle D$ is supplementary to $\angle A$?

But $\angle D$ is a right angle. Why?

Since $m\angle D = 90$; Why?

Therefore, $m\angle A = 90$.

Also, $\angle D$ is supplementary to $\angle C$. Why?

Hence $m\angle C = 90$; Why?

Therefore, $m\angle A = m\angle C = m\angle D$.

Can you give a similar argument to show that

$$m\angle B = m\angle D ?$$

What can you conclude about all angles in rectangle ABCD? What can you conclude about all angles in any rectangle?

A rhombus with one right angle is a square. Here are pictures of some squares:

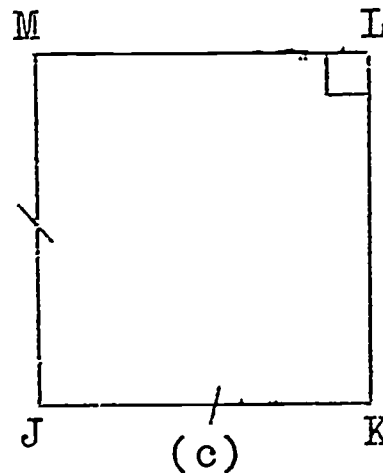
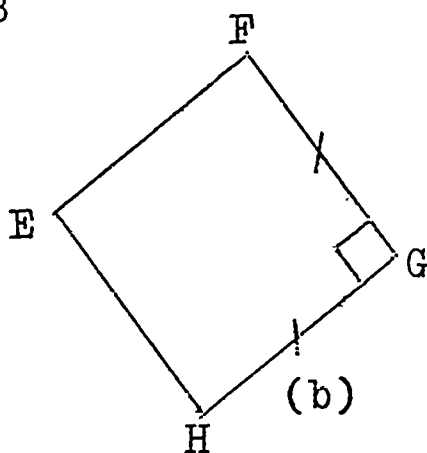
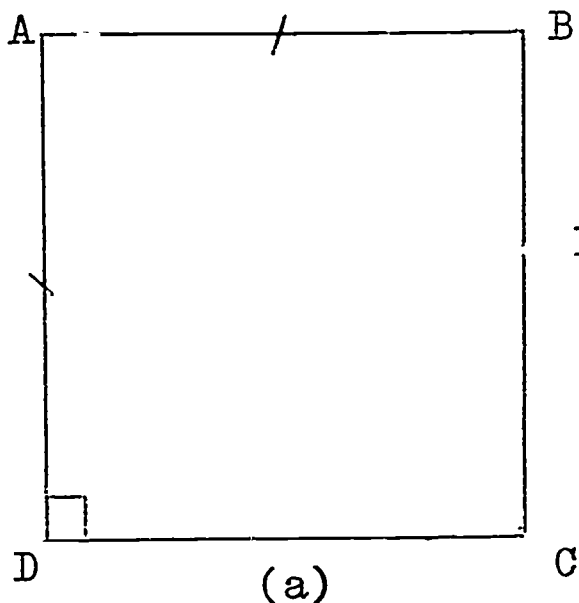

(3)

Since a square is a rhombus, what can you say about all of the sides of a square? Is a square also a rectangle? Why? What can you say about all the angles of a square?

We can also say that a square is a rectangle with two adjacent sides of equal measure.

Rhombuses, rectangles and squares have:

(1) all the properties of parallelograms

and

(2) rhombuses have all sides of equal measure.

(3) rectangles have four right angles.

(4) squares have all sides of equal measure and four right angles.

Here is a diagram to help you learn the various kinds of quadrilaterals:

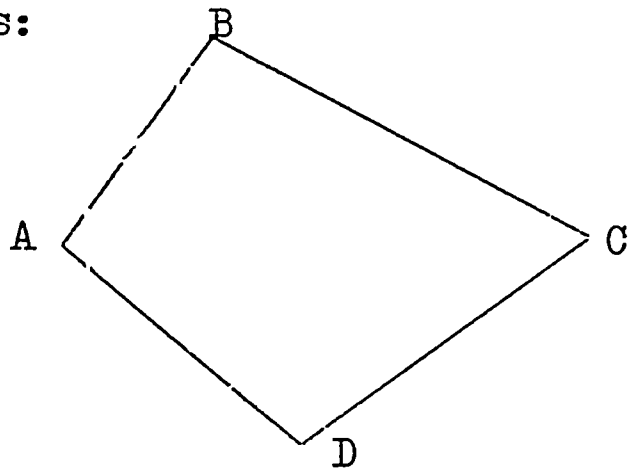

Quadrilateral

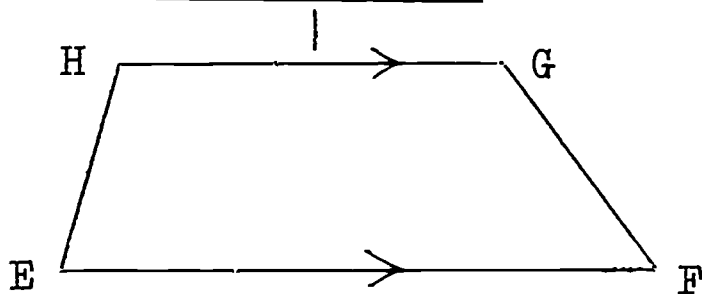

Trapezium

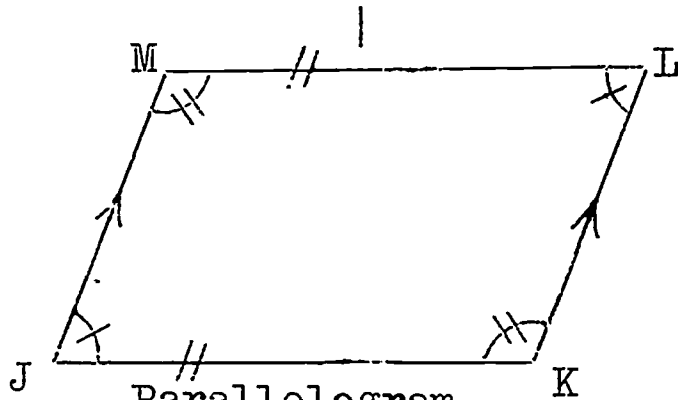

Parallelogram

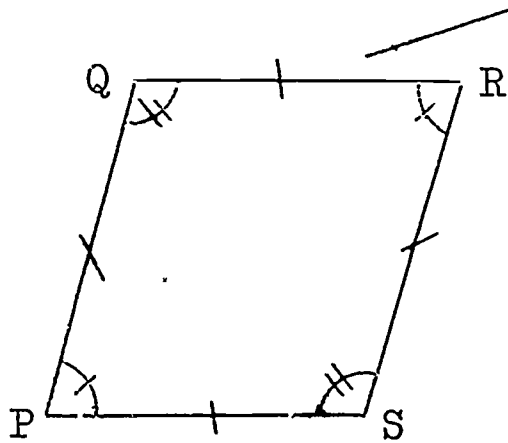

Rhombus

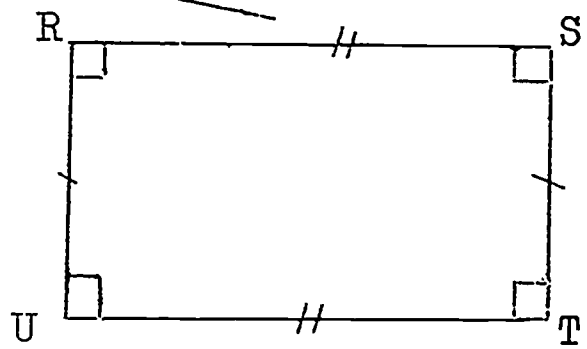

Rectangle

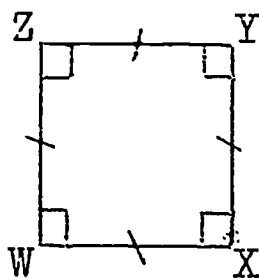

Square

Exercises 2-9

1. Given the rhombus ABCD in which the diagonals intersect at E:

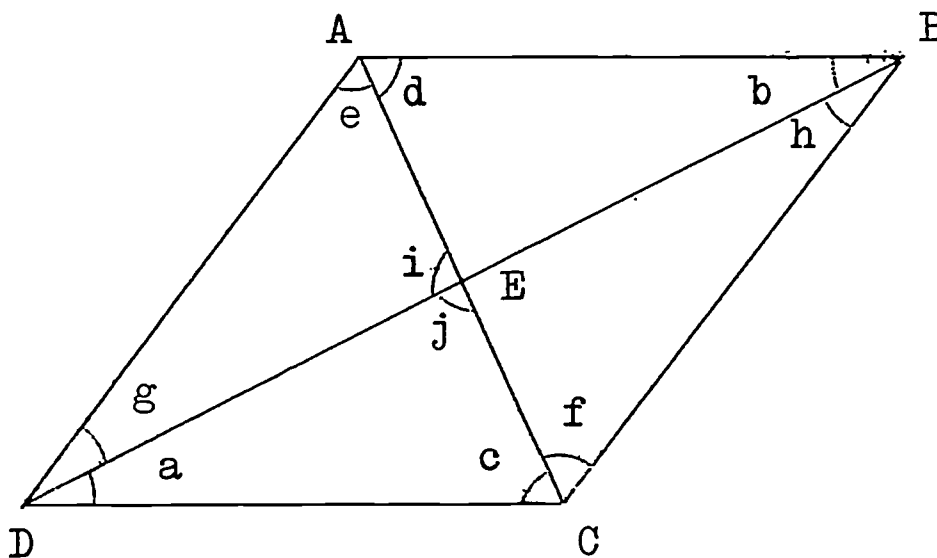

- a. Why is $m\angle a = m\angle b$? Use your protractor to check that these measures are equal.
- b. Why is $m\angle c = m\angle d$? Check these measures with your protractor.
- c. Is $m\angle e = m\angle f$? Why?
- d. Is $m\angle g = m\angle h$? Why?
- e. $(m\widehat{ABC} + m\widehat{BAD}) = ?$ Why?
- f. $(m\widehat{ADC} + m\widehat{DCB}) = ?$ Why?
- g. $m\angle i = ?$; $m\angle j = ?$; What is true of these measures?
- h. What kind of angles are $\triangle AEB$ and $\triangle BEC$?
- i. What can you say about the diagonals \overline{BD} and \overline{AC} ?
- j. $m\overline{AE} = ?$; $m\overline{EC} = ?$; What is true of these measures?
- k. $m\overline{BE} = ?$; $m\overline{ED} = ?$; What is true of these measures?
- l. What else can you say about the diagonals \overline{BD} and \overline{AC} ?

2. In your notebook, answer A if the sentence is always true, N if the sentence is never true, and S if the sentence is sometimes true and sometimes false:

- a. A rhombus is a parallelogram.
- b. A square is a rhombus.
- c. Parallelograms are rectangles.
- d. A rectangle is a square.
- e. Squares are rectangles.
- f. No rhombus is a parallelogram.
- g. A parallelogram is a rhombus.
- h. No rectangle is a square.
- i. A parallelogram is not a trapezium.
- j. A rhombus is a rectangle.
- k. A quadrilateral is a parallelogram.
- l. All parallelograms are quadrilaterals.
- m. A square is a parallelogram.
- n. Rhombuses are squares.
- o. A square is a trapezium.
- p. All rectangles are parallelograms.
- q. A rhombus is not a rectangle.
- r. No trapezium is a rhombus.
- s. A rhombus is a quadrilateral.
- t. No quadrilateral is a parallelogram.
- u. All trapeziums are parallelograms.
- v. No square is a rhombus.
- w. No rhombus is a square.
- x. Parallelograms are squares.
- y. No square is a rectangle.
- z. A trapezium is a parallelogram.

3. Given the rectangle $FGHI$ in which the diagonals intersect at point J :

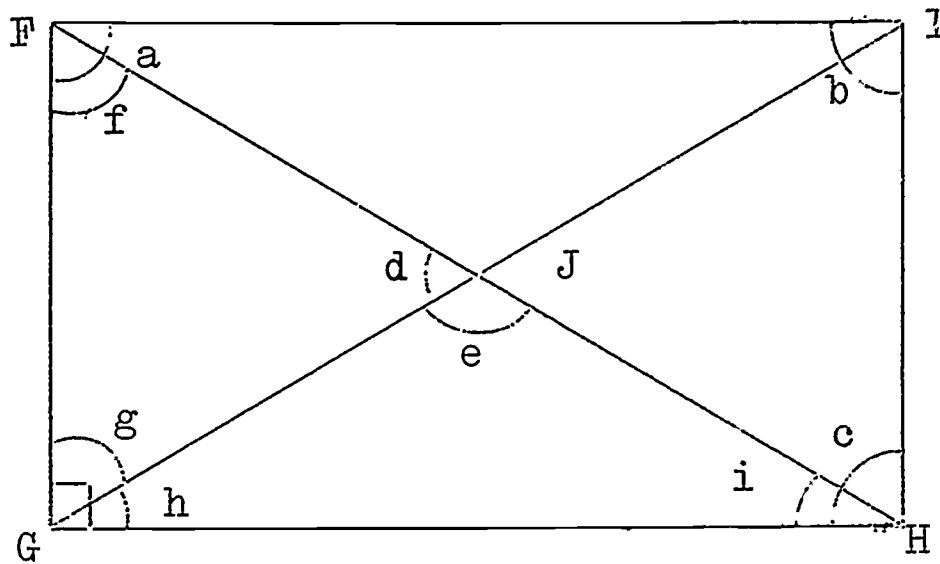

Answer each of the following without measuring:

- What do you think is true of angles a , b and c ?
- Is $m \angle d = m \angle e$?
- Do the diagonals bisect each other ? Are they perpendicular to each other ?
- Are the measures of the diagonals of the rectangle $FGHI$ equal ? Check your answer by measuring.
- Is $m \overline{FJ} = m \overline{GJ}$?
- What kind of triangle is $\triangle FJG$?
- What can you say about $m \angle f$ and $m \angle g$?
- Is $m \overline{GJ} = m \overline{HJ}$?
- What kind of triangle is $\triangle GJH$?
- Is $m \angle h = m \angle i$?

Copy rectangle $FGHI$ into your notebook.

- Shade $(\text{region } FGH) \cap (\text{region } IHG)$.
- $(\triangle GFI) \cap (\triangle HIF) = ?$
- Shade $(\text{region } FGH) \cup (\text{region } GFI)$.
- $(\triangle GHI) \cap (\triangle FIH) = ?$

4. Given the square $FGHI$ in which the diagonals intersect at point J :

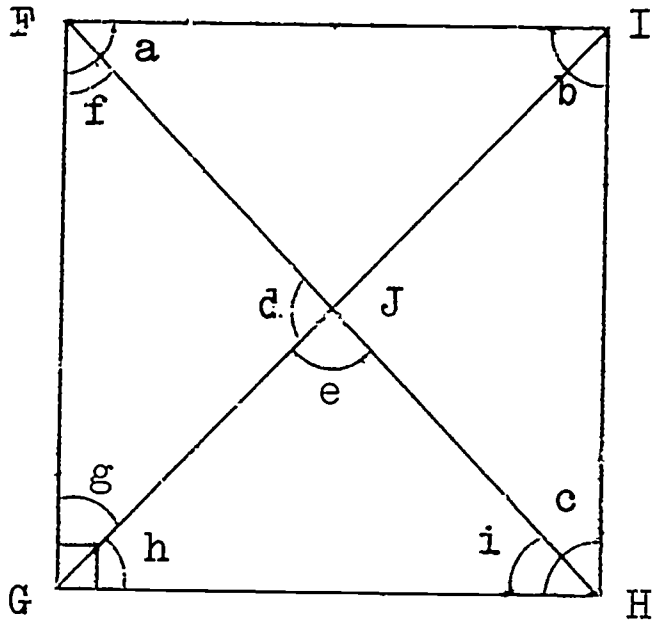

Answer Questions (a) - (n) of Exercise 3 above, but refer to this square $FGHI$.

5. In your notebook, answer T if the sentence is always true, and F if the sentence is not always true. Draw figures to help you answer correctly.
- The measures of the opposite sides of a parallelogram are equal.
 - The measures of the diagonals of a rhombus are equal.
 - The measures of the diagonals of a parallelogram are equal.
 - The diagonals of a rectangle have the same measure.
 - A trapezium has two pairs of opposite sides of the same measure.
 - An isosceles trapezium has all four sides of the same measure.
 - Consecutive angles of a parallelogram have the same measure.
 - Opposite angles in a rhombus have the same measure.
 - Consecutive angles in a parallelogram are supplementary.
 - Adjacent sides of a rhombus have the same measure.

6. In each question, write the names of all the quadrilaterals which satisfy the conditions of that question:
- One pair of opposite sides parallel.
 - Two pairs of opposite sides parallel and diagonals of the same measure.
 - Diagonals are perpendicular to each other.
 - Opposite sides are parallel, and one right angle.
 - Opposite sides are parallel and adjacent sides are of the same measure.
 - Diagonals are of the same measure and are perpendicular to each other.
 - Consecutive angles are supplementary.
 - Consecutive angles are supplementary and of the same measure.
 - Opposite angles are of the same measure.
 - Diagonals bisect each other.

2-10 Polygons of More than Four Sides

You have learnt that a polygon of three sides is called a triangle, and one of four sides is called a quadrilateral.

Here is a table to help you learn the names of some other polygons:

<u>Number of sides:</u>	<u>Name of polygon:</u>
3	Triangle
4	Quadrilateral
5	Pentagon
6	Hexagon
7	Heptagon
8	Octagon
9	Nonagon
10	Decagon
⋮	⋮
15	15-gon
⋮	⋮
n	n-gon

How many vertices does an octagon have ? How many angles does a pentagon have ? How many sides does a 23-gon have ?

Look at the following polygon:

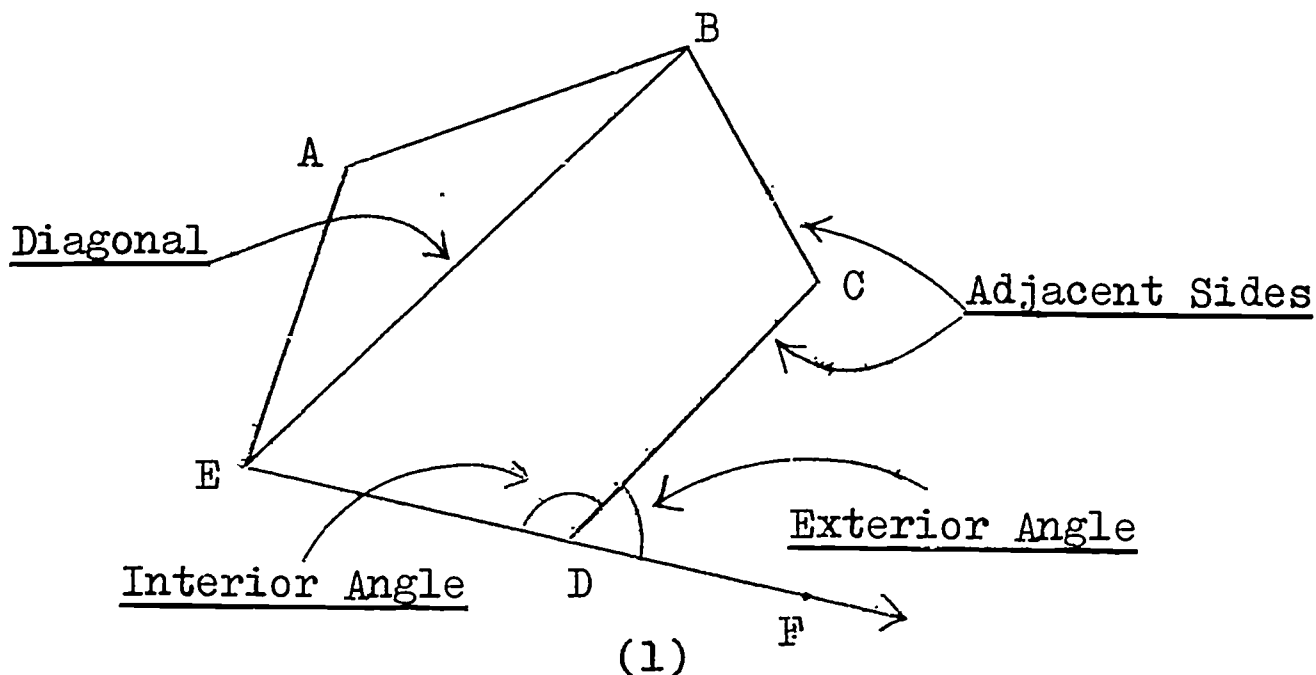

In figure (1), notice that \overline{ED} is extended to form \overline{EF} . $\angle CDF$ is called an exterior angle of the polygon. Is the exterior angle $\angle CDF$ the supplement of $\angle EDC$? Why ?

A polygon with all sides of equal measure is called an equilateral polygon.

A polygon with all angles of equal measure is called an equiangular polygon.

A polygon with all sides of equal measure and all angles of equal measure is called a regular polygon.

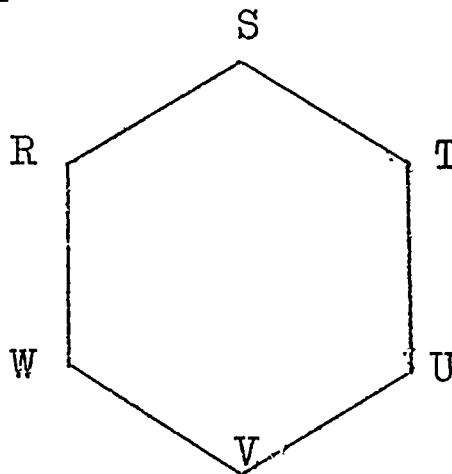
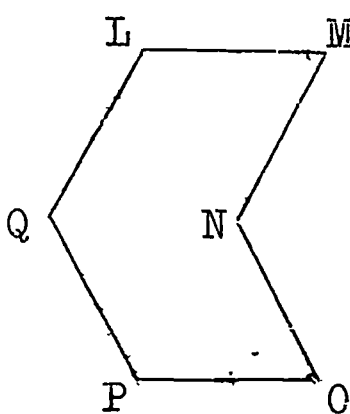
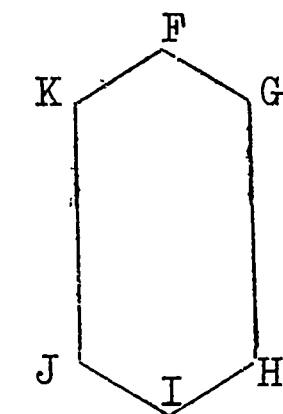

Equiangular Polygon

Equilateral Polygon

Regular Polygon

(2)

Notice that a regular polygon is both equiangular and equilateral.

Is a rhombus an equilateral polygon? Is an equilateral triangle a regular polygon? Is a square a regular polygon? Are all rectangles regular polygons?

Exercises 2-10

1. a. Draw pictures of three different equilateral polygons.
b. Draw pictures of three different equiangular polygons.
c. Draw pictures of three different regular polygons.
2. In each of the following, state whether the figure is equilateral, equiangular, regular, or none of these. Use your ruler and protractor to help you decide.

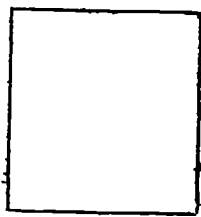

a.



b.

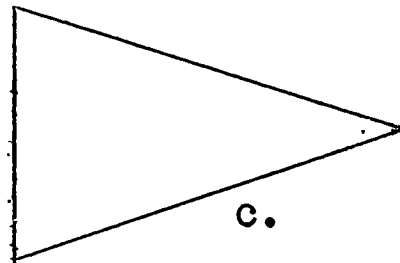

c.

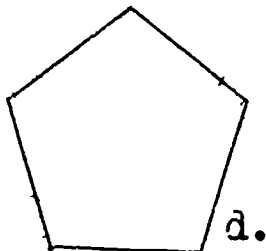

d.

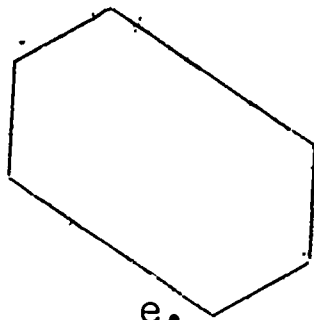

e.

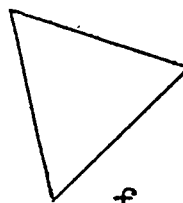

f.

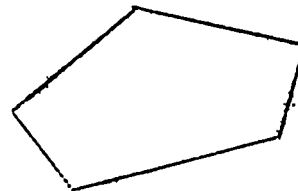

g.

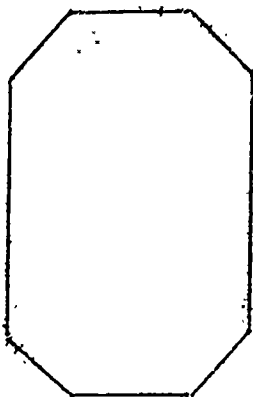

h.

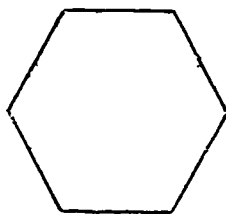

i.

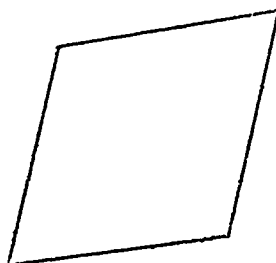

j.

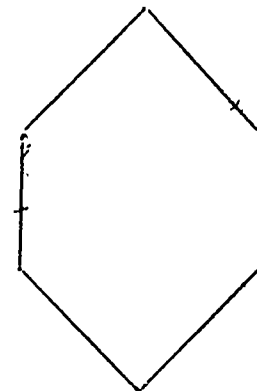

k.

3. a. Is every equilateral polygon also equiangular ?
 b. Are some equiangular polygons also equilateral ?
 c. Is every equiangular polygon also regular ?
 d. Is every regular polygon equiangular ?
 e. Are some equiangular polygons also equilateral ?
4. a. How many angles does a 23-gon have ? a hexagon ? a nonagon ? a 107-gon ?
 b. How many sides has a polygon which contains 17 angles ? 32 angles ? 6 angles ?

2-11 Sum of Measures of the Interior Angles of a Polygon

In Section 2-5, we said that the sum of the measures of the angles of any triangle is 180.

Now look at the quadrilateral ABCD:

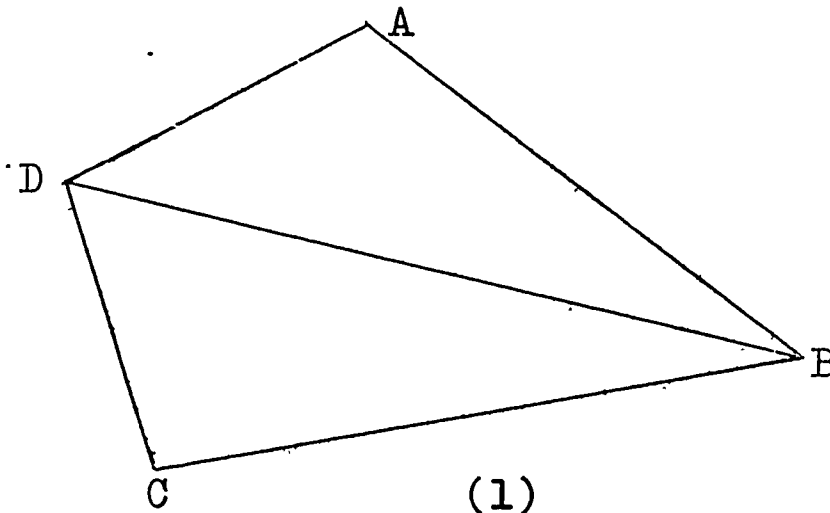

In figure (1), into how many triangles does the diagonal \overline{DB} separate ABCD ? Since there are two triangles, the sum S of the angles of the quadrilateral ABCD is:

$$\begin{aligned}
 S &= 2 \times 180 \\
 &= (4 - 2) \times 180 \\
 &= 360 .
 \end{aligned}$$

Check this number by measuring each angle of ABCD in figure (1), and adding those measures.

Now look at this pentagon ABCDE:

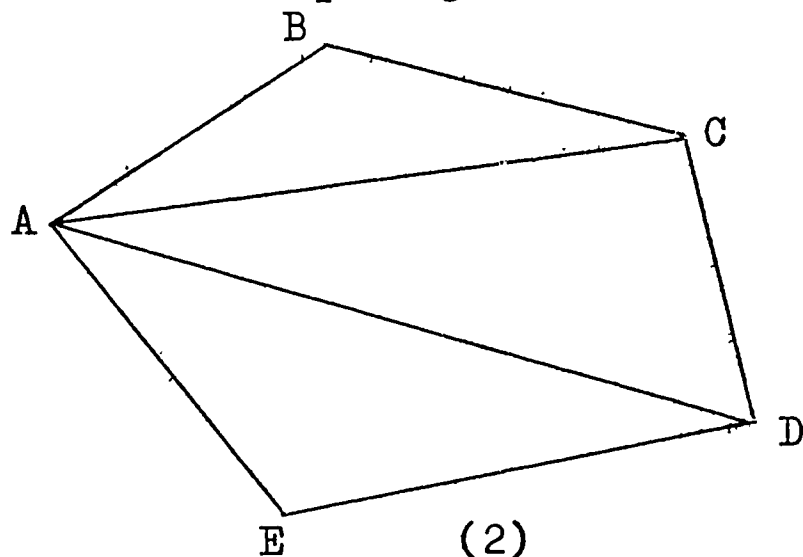

The diagonals \overline{AD} and \overline{AC} separate the pentagon into $(5 - 2) = 3$ triangles. There are 180 degrees contained in each triangle. Hence, the sum S of the measures of the angles of the pentagon ABCDE is:

$$\begin{aligned} S &= (5 - 2) \times 180 \\ &= 3 \times 180 \\ &= 540 . \end{aligned}$$

Check this number by measuring each angle of the pentagon in figure (2), and finding the sum of these measures.

Now look at these figures:

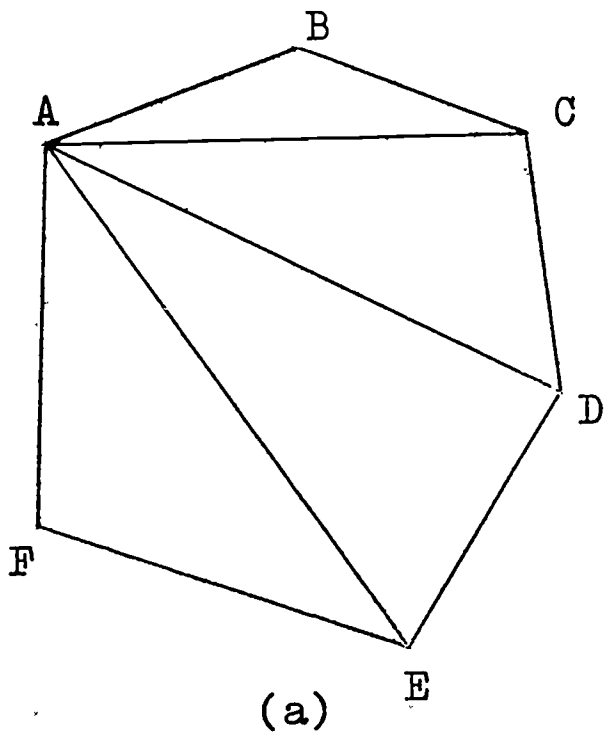

Polygon ABCDEF:

6 sides

(6-2) triangles

$$\begin{aligned} S &= (6 - 2) \times 180 \\ &= 4 \times 180 \\ &= 720 \end{aligned}$$

(a)

(3)

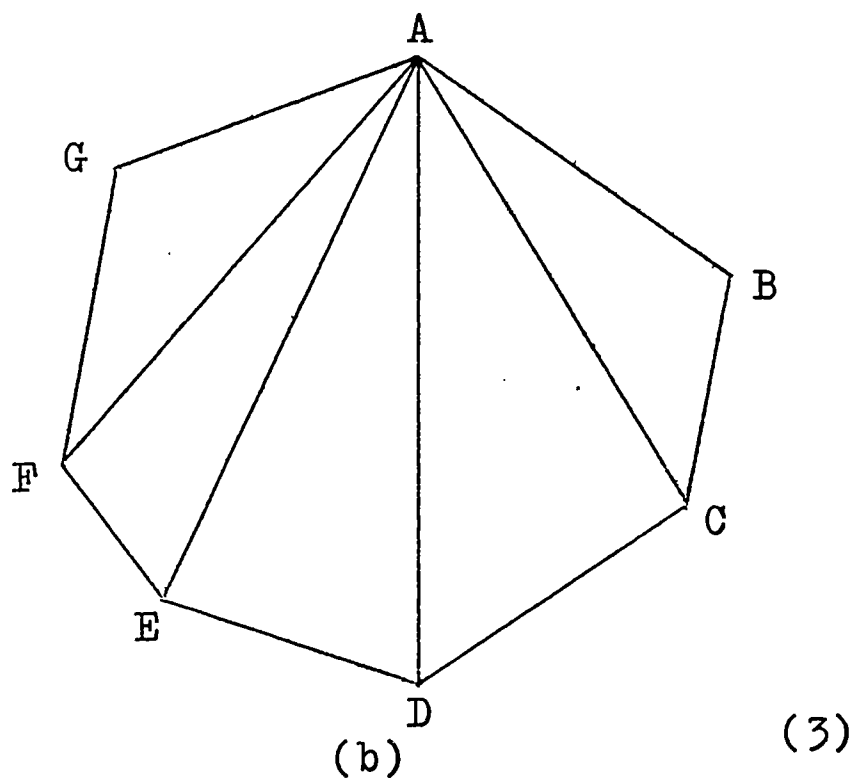

Polygon ABCDEFG:

7 sides

(7-2) triangles

$$S = (7-2) \times 180$$

$$= 5 \times 180$$

$$= 900$$

If a polygon has n sides, then the sum S of the measures of the interior angles of that polygon is:

$$S = (n - 2) \times 180 .$$

The sum S of the measures of the interior angles of a polygon of n sides is:

$$S = (n - 2) \times 180$$

Exercises 2-11

1. Find the sum of the measures of the interior angles of the following polygons:

a. pentagon

d. 15-gon

b. quadrilateral

e. decagon

c. hexagon

f. n -gon

2. Given the following figure with data as marked:

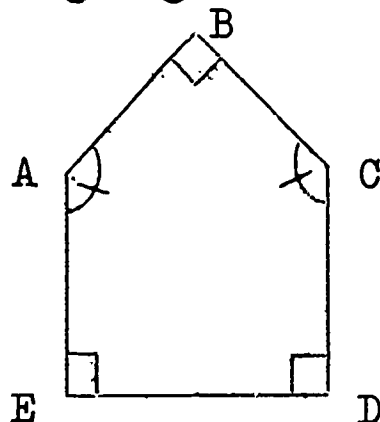

Find $m\angle A$ and $m\angle C$ without measuring.

3. Given the following figure with data as marked. Find the following without measuring:

- $m\angle DEC = ?$; $m\angle DCE = ?$
- $m\angle DEF = ?$; $m\angle DCB = ?$
- $m\angle ABC = ?$
- What is the sum of the measures of the interior angles of the polygon $ABCDEF$?
- $m\angle A = ?$

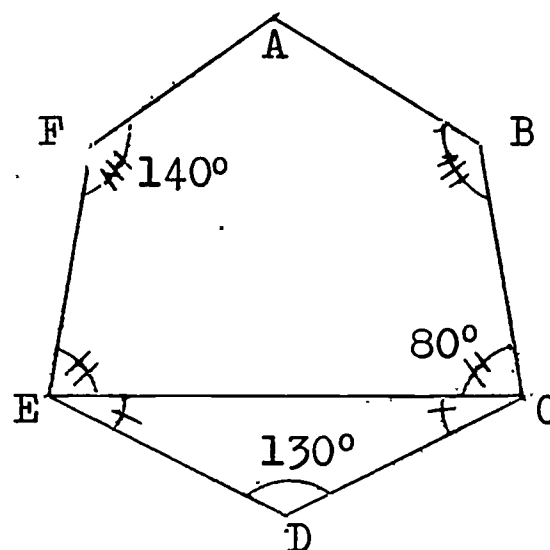

4. Complete the following table:

Number of Sides	Number of Triangles	Sum of Measures of Interior Angles	Measure of each Angle if Polygon is <u>Regular</u>
3	$3-2 = 1$	$1 \times 180 = 180$	$180 \div 3 = 60$
4	$4-2 = 2$	$2 \times 180 = 360$	$360 \div 4 = 90$
5	-	-	-
6	$6-2 = 4$	$4 \times 180 = 720$	$720 \div 6 = 120$
8	-	-	-
9	-	-	-
10	-	-	-
12	-	-	-
n	-	-	-

2-12 Sum of Measures of the Exterior Angles of a Polygon

Consider a triangle ABC with the sides produced in order, as shown in figure (1):

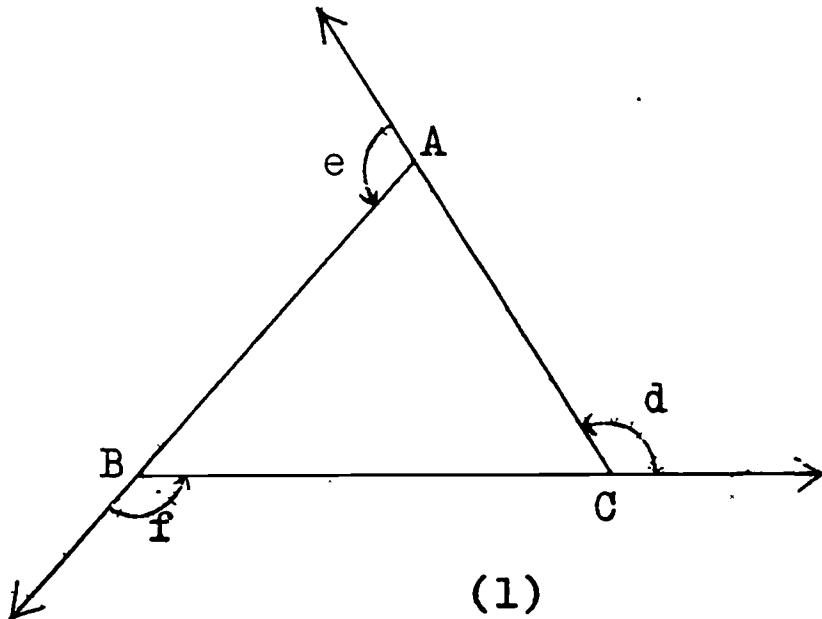

We want to find the sum of the measures of the exterior angles of $\triangle ABC$:

$$m \angle d + m \angle e + m \angle f = ?$$

Imagine a man walking along \overrightarrow{BC} . On getting to point C , he changes his direction to \overrightarrow{CA} . Through what angle does the man turn? Do you agree that he turns through $\angle d$? On getting to point A , he changes his direction to \overrightarrow{AB} . Through what angle does the man now turn? On getting to point B , he must turn through $\angle f$ in order to face the original direction of \overrightarrow{BC} . What is the total amount of rotation that the man has turned? Has the man made one complete turn? How many degrees are there in one complete revolution?

Thus: $m \angle d + m \angle e + m \angle f = 360$.

Suppose the original figure were a quadrilateral. Does the man still make one complete turn when he has rotated through the four exterior angles? If the figure were a pentagon, does the man still complete one revolution? If the

figure were a hexagon ? A 15-gon ? A polygon of any number of sides ? In each polygon, the man rotates 360° . Hence, the sum of the measures of the exterior angles of a polygon of n sides is 360 .

The sum of the measures of the exterior angles of a polygon of n sides is 360 .

Exercises 2-12

1. What is the measure of each exterior angle of a regular polygon with the given number of sides ?

a. 6	d. 15	g. 30
b. 8	e. 18	h. 45
c. 12	f. 20	i. n

2. How many sides has a regular polygon if the measures of each exterior angle is as follows ?

a. 15	d. 90	g. 36
b. 30	e. 120	h. 1
c. 60	f. 5	i. n

3. Find the measure of an interior angle of a regular polygon with the given number of sides:

a. 12	c. 10	e. 18
b. 15	d. 22	f. n

4. Find the number of sides of a regular polygon if the measure of each interior angle is:

a. 170	c. 150	e. 108
b. 165	d. 156	f. 120

2-13 Circles

We now want to consider simple closed curves called circles. Here is a picture of a circle:

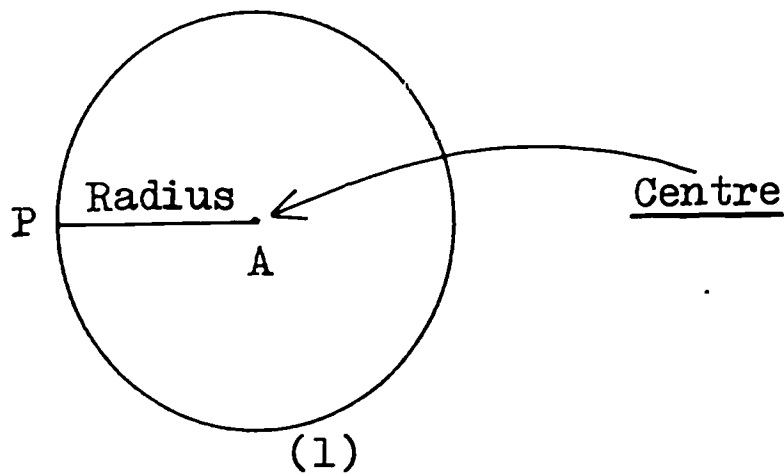

A circle is the set of points the same distance from a given point. That given point is called the centre of the circle. In figure (1), A is the centre of the circle. The distance from the centre to the circle is called the radius of the circle. In figure (1), \overline{AP} is a radius of the circle A.

You know that the instrument we use to make a circle is called a compass.

Here is another picture of a circle with some important names given:

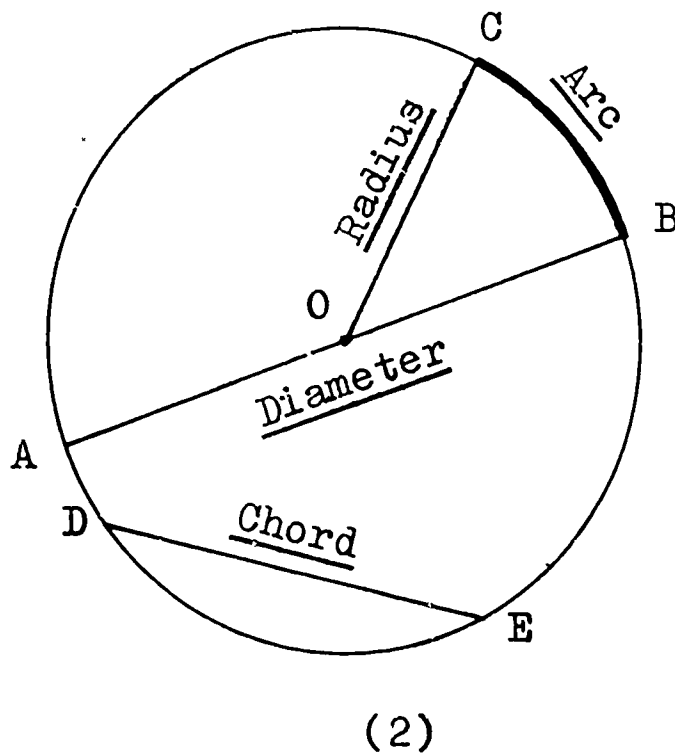

A chord is a line segment with both endpoints on the circle. \overline{DE} is a chord in figure (1) .

A diameter is a chord which passes through the centre of the circle. \overline{AB} is a diameter in figure (1) .

A radius is a segment with one endpoint at the centre and one endpoint on the circle. \overline{OB} and \overline{OC} are radii of circle O.

An arc consists of two points on the circle and all points on the circle between them. \widehat{CB} is an arc in figure (1). Notice the symbol " $\widehat{\quad}$ " for "arc" .

Exercises 2-13

1. a. Draw a circle of radius 1.5 inches, and call the centre point A.
 b. Draw a radius \overline{AB} .
 c. Draw another radius \overline{AC} such that $m\angle BAC = 60$.
 d. Draw the chord \overline{BC} .
 e. What kind of triangle is $\triangle ABC$?
2. a. Draw a circle of radius 4 cms. with B as centre.
 b. Draw a diameter \overline{AC} .
 c. Let D be any point on the arc AC. Draw \overline{DA} and \overline{DC} .
 d. $m\angle CDA = ?$
 e. Let E be another point on the arc AC but on the opposite side of \widehat{AC} from D. Draw \overline{EC} and \overline{EA} .
 f. $m\angle CEA = ?$
 g. What do you notice about angles CDA and CEA?
3. a. Draw another circle with radius 2 inches and repeat parts (2b) to (2f) above.
 b. What do you notice about the angles CDA and CEA for this circle?

4. Draw these designs with your compass and ruler:

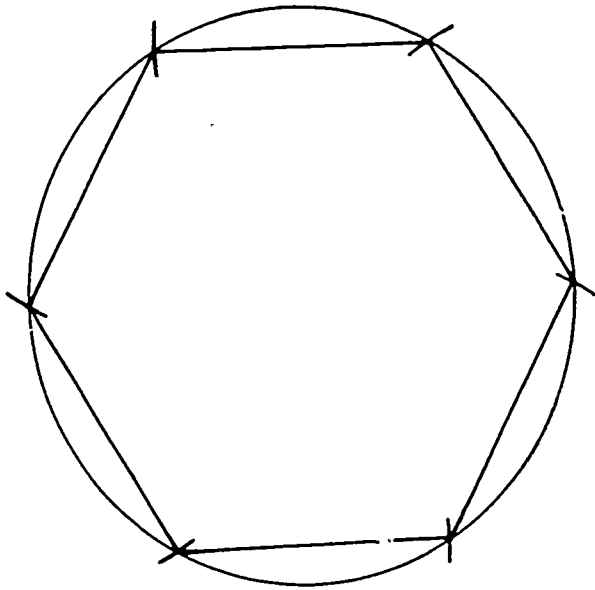

a.

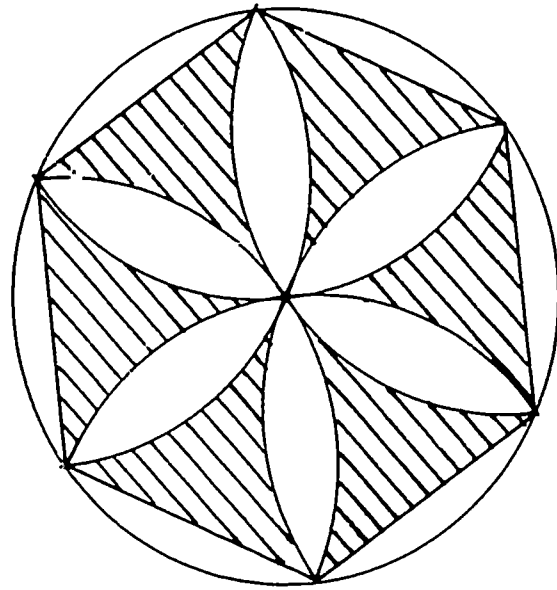

b.

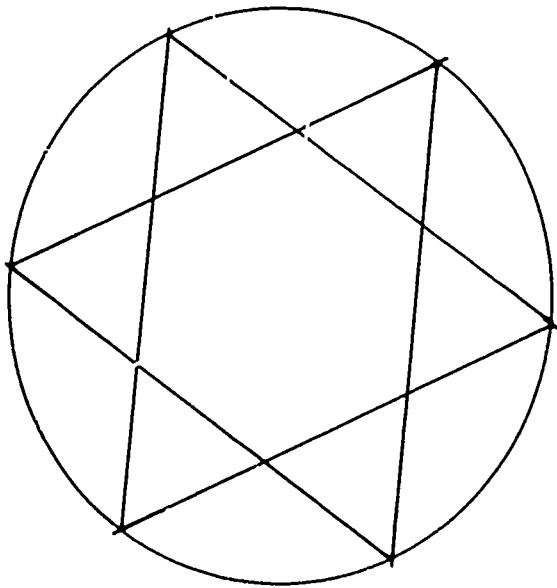

c.

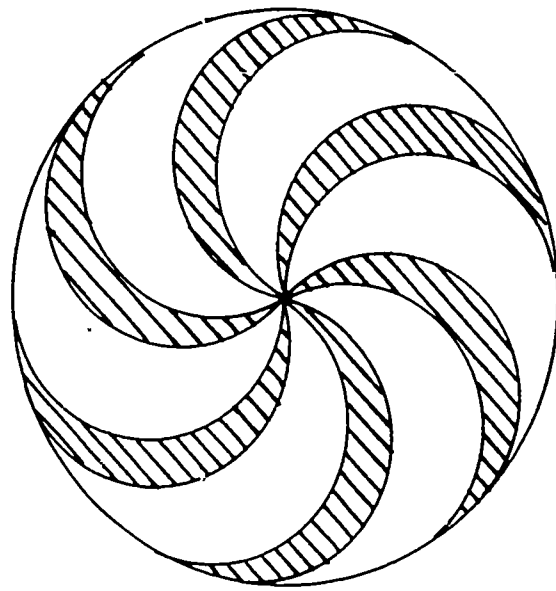

d.

Draw three or more original designs with your compasses and ruler. Sometimes shading helps to make the design more attractive.

Revision Test # 3

I. Fill in the blank to make each sentence true:

1. A polygon is a _____ made up of line segments.
2. A polygon with one pair of sides parallel is a _____.
3. An angle and its _____ add to 180.
4. Adjacent angles have _____ interior points in common.
5. $m \angle RST = 72$. The bisector of $\angle RST$ forms two angles each with measure of _____.
6. P is the midpoint of \overline{AB} . $m \overline{AP} = 3$. $m \overline{AB} =$ _____.
7. How many obtuse angles does an obtuse triangle have? _____
8. A right triangle has _____ right angles.
9. A line segment connecting two points on a circle is a _____.
10. A scalene triangle has _____ equal sides.

II. Answer A if the sentence is always true, N if the sentence is never true, and S if the sentence is sometimes true:

1. An isosceles triangle is equilateral. _____
2. A parallelogram is a rhombus. _____
3. A circle is a set of points. _____
4. A square is a regular polygon. _____
5. A parallelogram with two adjacent sides of equal measure is a square. _____
6. A rhombus is a quadrilateral. _____
7. A scalene triangle is equilateral. _____
8. A diameter is a chord. _____
9. A rhombus is a rectangle. _____
10. The sum of the interior angles of a pentagon is 540. _____

III. Find the value of each of the unknown angles.

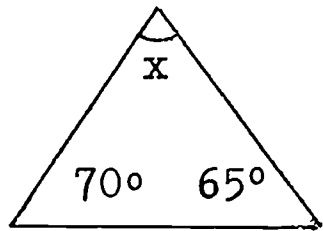

1.

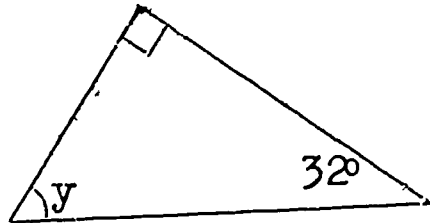

2.

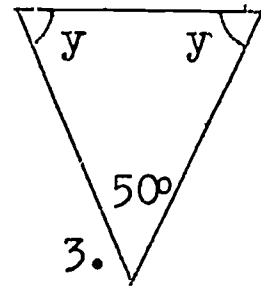

3.

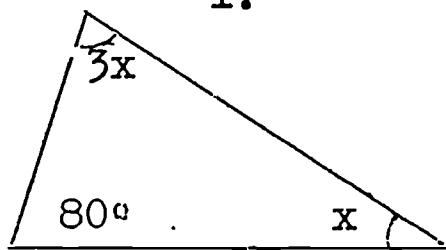

4.

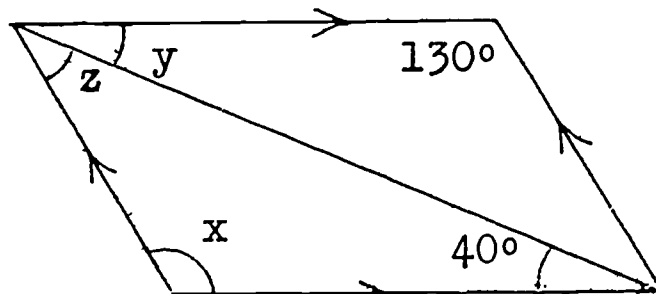

5.

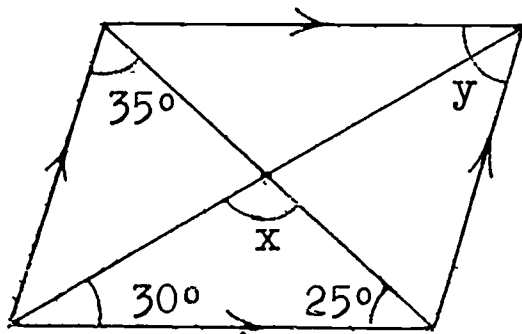

6.

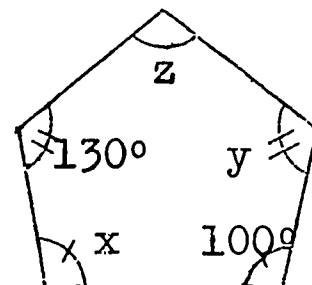

7.

IV. Show all work clearly and neatly in your notebook:

1. A regular polygon has 11 sides. Find the sum of the measures of two angles.
2. There are 7 diagonals from one vertex of a regular polygon. Find the sum of the interior angles of the polygon.

3. Given the following figure in which:

$$m \angle S = 90$$

$$m \angle R = 120$$

$$m \angle T = m \angle R + 10$$

$$m \angle V = x$$

$$m \angle U = x$$

a. $m \angle T =$ _____

b. $m \angle V =$ _____

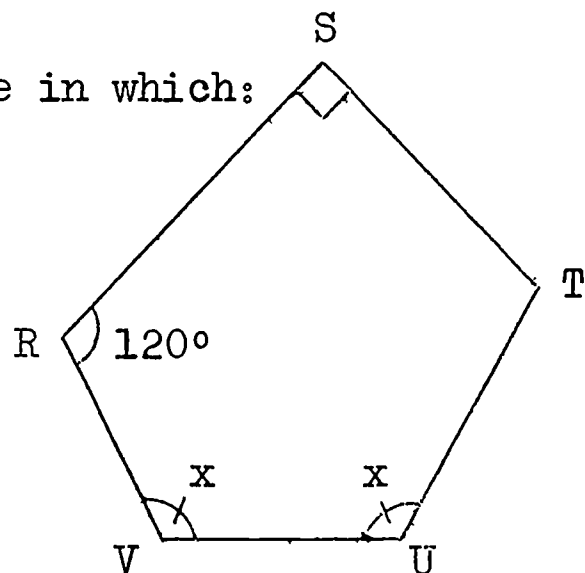

Revision Test # 4

I. Fill in the blank with the correct word, phrase, or number:

1. In a right triangle, one acute angle has measure 35.
The other acute angle has measure _____ .
2. Two angles of a triangle have measure 10 and 15. The
third angle has measure _____ .
3. In parallelogram ABCD, $m \angle A = 105$. $m \angle B =$ _____ .
4. In parallelogram RSTU, $m \angle S = 87$. $m \angle U =$ _____ .
5. A square is a _____ .
6. A diameter is a chord which _____ .
7. A chord is a _____ .
8. A polygon with six sides is called a _____ .
9. The sum of the exterior angles of a nonagon is _____ .
10. In an isosceles triangle, the two equal angles each
measure 33. The measure of the third angle is _____ .
11. In an obtuse triangle, one obtuse angle measures 140.
The measure of the other obtuse angle is _____ .
12. The measure of each interior angle of a regular pentagon
is _____ .
13. A quadrilateral with one pair of parallel sides is a
_____ .
14. In parallelogram WXYZ, $m \overline{WX} = m \overline{XY}$. The parallelogram
is a _____ .
15. A triangle with no sides of equal measure is a _____ .
16. A right triangle has _____ right angle.

Use figure (1) to answer 17 - 20:

17. \overline{RT} is a _____ .
18. \overline{AB} is a _____ .
19. \overline{TB} is a _____ .
20. \widehat{RB} is a(n) _____ .

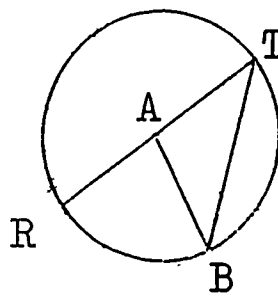

(1)

II. Use figure (2) to answer all parts of this question. Use your protractor to measure the angles.

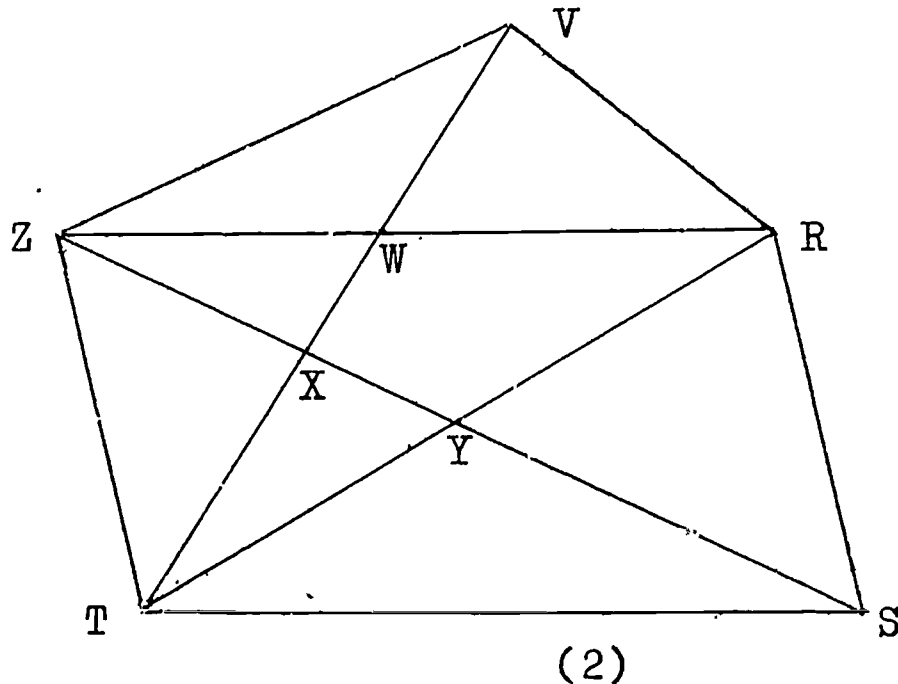

1. Polygon RSTZV is a _____ .
2. Polygon WRST is a _____ .
3. Polygon ZXW is a _____ .
4. $m \angle SYT =$ _____ .
5. $m \angle YST =$ _____ .
6. $m \overline{XY} =$ _____ .
7. $m \angle RVZ =$ _____ .
8. $m \angle ZTS =$ _____ .
9. $m \angle YXR =$ _____ .

III. Answer A if the statement is always true, S if the statement is sometimes true, or N if the statement is never true:

- _____ 1. A scalene triangle has two sides of equal measure.
- _____ 2. A trapezium has two pairs of parallel sides.
- _____ 3. A rhombus has all angles of equal measure.
- _____ 4. A triangle has angles of measure 76, 81 and 26.
- _____ 5. An obtuse triangle has one angle of measure 20.
- _____ 6. A parallelogram has interior angles of measure 90, 80, 100 and 90.
- _____ 7. An acute triangle has one angle of measure 113.
- _____ 8. A scalene triangle has sides of measure 4, 7, 5.
- _____ 9. A rhombus is a pentagon with all sides of equal measure.
- _____ 10. If we know the measure of two angles of a triangle, we can find the measure of the third angle.

IV. Given figure (3) in which $STUV$ is a parallelogram, and angles marked with given measures:

Find each of the following without using a protractor:

1. $m \angle T =$ _____ .
2. $m \angle SUV =$ _____ .
3. $m \angle SVU =$ _____ .
4. $m \angle R =$ _____ .
5. $m \angle RVU =$ _____ .

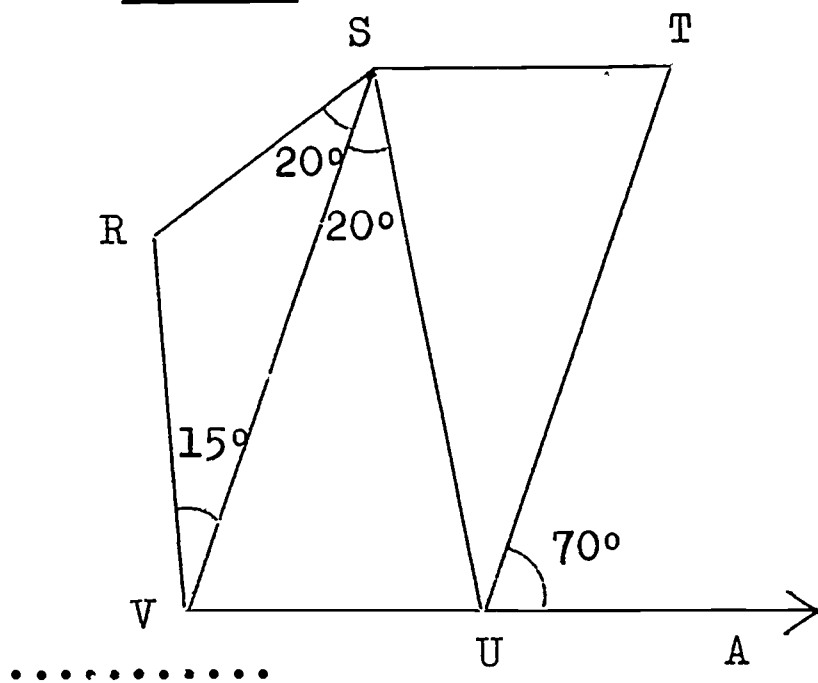

Cumulative Revision Test # 1

I. Answer each of the following by "none" , "one" , or "many" .

1. Through two points, _____ line(s) can be drawn.
2. Through two points, _____ plane(s) can be drawn.
3. Through one point, _____ line(s) can be drawn.
4. Through three points, _____ plane(s) can be drawn.
5. If three lines are parallel, their intersection is how many points ? _____
6. Through one line, _____ plane(s) can be drawn.
7. Through three points, _____ triangle(s) can be drawn.
8. If two lines are not parallel in a plane, then their intersection is how many points ? _____
9. Through three points, _____ quadrilateral(s) can be drawn.
10. If two planes are not parallel, their intersection is _____ line(s).

II. Match the phrase on the left with the statement or word on the right by writing the correct letter in the space provided. Do your work in your notebook.

- | | | |
|--|-------|--|
| A. A chord passing through the centre of a circle. | _____ | 1. $\angle ABC$ |
| B. The union of \overrightarrow{CA} and the half-line of \overrightarrow{CB} containing point B. Point A is on \overrightarrow{CB} . | _____ | 2. \overleftrightarrow{AB} |
| C. All points on the line which contain A and B. | _____ | 3. $\triangle ABC$ |
| D. $\overrightarrow{AB} \cup \overrightarrow{AC}$ | _____ | 4. $\overline{AB} \parallel \overline{CD}$ |
| E. Obtuse $\angle BAC$ | _____ | 5. equilateral |
| F. $\overleftrightarrow{AB} \cap \overleftrightarrow{CD} = \emptyset$ | _____ | 6. square |
| G. All points on the line between A and B, including A and B. | _____ | 7. diameter |
| H. $\overline{AB} \perp \overline{BC}$ | _____ | 8. $m \angle ABC = 90$ |
| I. A parallelogram with adjacent sides of equal measure. | _____ | 9. complementary |
| J. $\overline{AB} \cup \overline{BC} \cup \overline{CA}$ | _____ | 10. \overleftrightarrow{AB} |
| K. Set of all points the same distance from a given point. | _____ | 11. circle |
| L. A triangle all of whose sides are of equal measure. | _____ | 12. $90 < m \widehat{BAC} < 180$ |
| M. A rectangle with adjacent sides of equal measure. | _____ | 13. rhombus |
| N. The sum of the measures of two angles is 180. | _____ | 14. supplementary |
| P. The sum of the measures of two angles is 90. | _____ | 15. \overline{AB} |

III. Given the following figure:

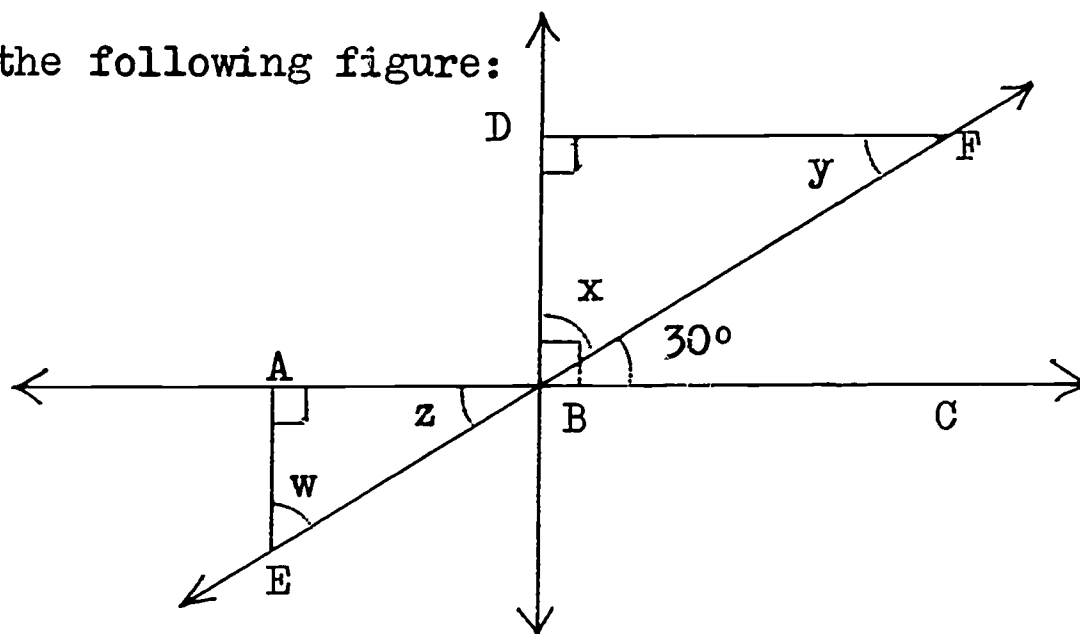

Find each of the following without measuring:

a. $m \angle x =$ _____

b. $m \angle z =$ _____

c. $m \angle y =$ _____

d. $m \angle w =$ _____

e. $\overline{DF} \underline{\hspace{1cm}} \overline{AC}$

f. $\overline{AE} \underline{\hspace{1cm}} \overline{AC}$

g. $\overline{DB} \underline{\hspace{1cm}} \overline{AE}$

IV. Given the following figure in which $ABCDEF$ is a regular hexagon:

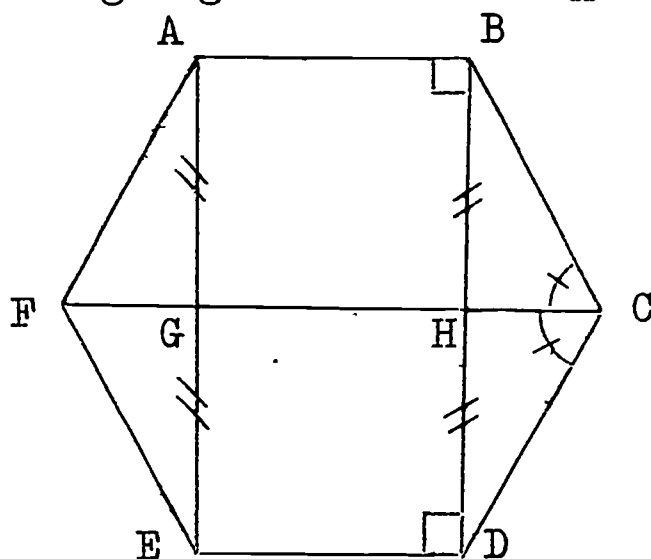

Answer each of the following without measuring:

a. $m \angle ABC =$ _____

b. $m \angle ABH =$ _____

c. $m \angle HBC =$ _____

d. $m \angle BCH =$ _____

e. $m \angle CDE =$ _____

f. $(m \widehat{HCD} + m \widehat{CDE}) =$ _____

g. What is true of $m \overline{CD}$ and $m \overline{FE}$?

h. $FCDE$ is a _____ .

i. What is true of \overline{AB} and \overline{ED} ?
of \overline{BD} and \overline{AE} ?

j. $ABDE$ is a _____ .

- V. Given the following triangle in which P is the midpoint of \overline{AB} , Q is the midpoint of \overline{AC} , and R is the midpoint of \overline{BC} :

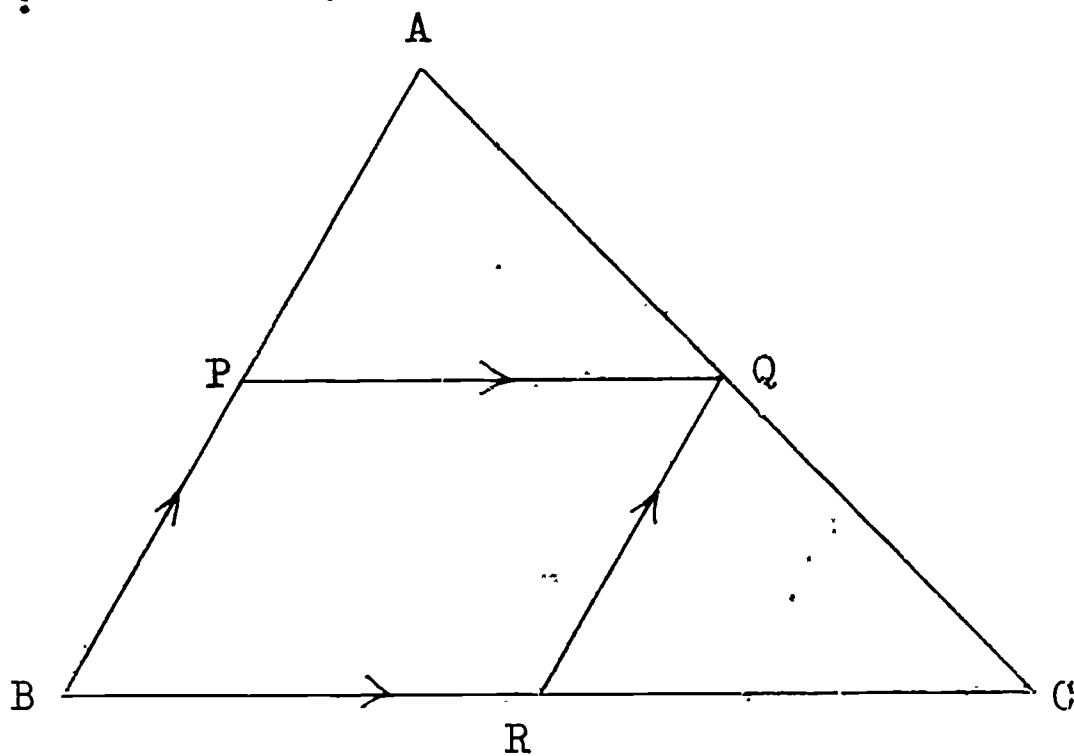

1. If $m \angle B = 60$, then $m \angle APQ = \underline{\hspace{2cm}}$.
2. $\overline{PQ} \underline{\hspace{1cm}}$ \overline{BC} .
3. $m \angle BRQ = \underline{\hspace{2cm}}$.
4. $\overline{RQ} \underline{\hspace{1cm}}$ \overline{AB} .
5. $m \overline{BR} \underline{\hspace{1cm}}$ $m \overline{RC}$.
6. $m \overline{PQ} \underline{\hspace{1cm}}$ $m \overline{BR}$.
7. $m \overline{PQ} \underline{\hspace{1cm}}$ $m \overline{RC}$.
8. What is the relationship between $m \overline{PQ}$ and $m \overline{BC}$?

.....

Chapter 3
Congruent Figures

3-1 Introduction

In this Chapter, we want to study an important relationship between plane figures. That relationship is called congruence.

Look at this picture:

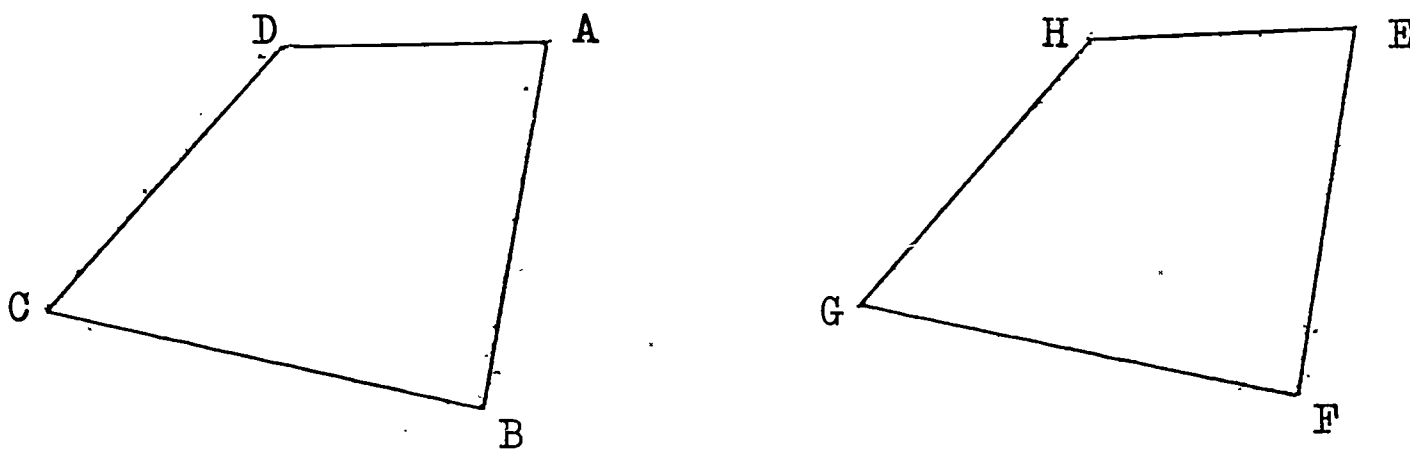

(1)

If you cut out $ABCD$ and $EFGH$, and place one on top of the other, would the two figures fit exactly? Would $\angle A$ fit exactly on $\angle E$? Would $\angle B$ fit exactly on $\angle F$? $\angle C$ on $\angle G$? $\angle D$ on $\angle H$? Would \overline{AB} fit exactly on \overline{EF} ? Would \overline{BC} fit exactly on \overline{FG} ? \overline{CD} on \overline{GH} ? \overline{DA} on \overline{HE} ?

We say that two figures are congruent if one can be made to fit exactly on the other. Are $ABCD$ and $EFGH$ congruent figures?

Are $ABCD$ and $EFGH$ of the same shape? Are they of the same size? Two congruent figures have exactly the same size and shape.

Two figures are congruent if one can be made to fit exactly on the other.

3-2 Congruent Segments and Congruent Angles

Look at these two line segments:

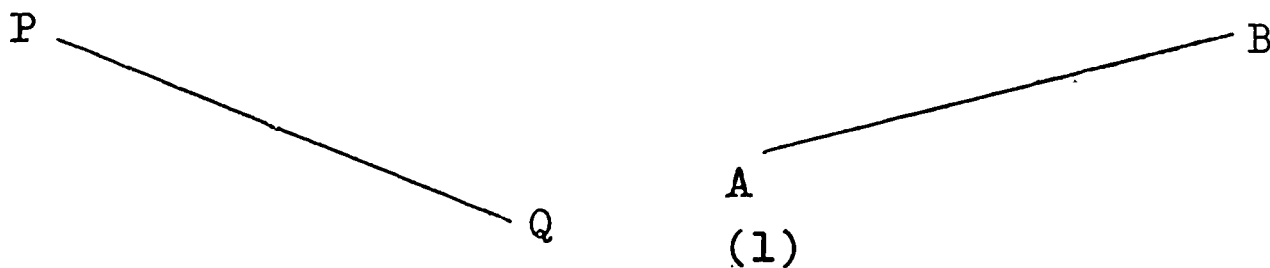

Draw \overline{PQ} on a piece of tracing paper. Now try to fit your tracing of \overline{PQ} onto \overline{AB} . If you traced carefully, you will find that \overline{PQ} fits exactly onto \overline{AB} . Thus we say that \overline{PQ} is congruent to \overline{AB} , and we write:

$$\overline{PQ} \cong \overline{AB} .$$

The symbol " \cong " means "is congruent to".

Carefully measure \overline{PQ} and \overline{AB} . $m \overline{PQ} = ?$ $m \overline{AB} = ?$ You notice that \overline{PQ} and \overline{AB} have equal measures. If two line segments are congruent, then they have equal measures. Also, segments having equal measures are congruent segments.

Now look at this picture:

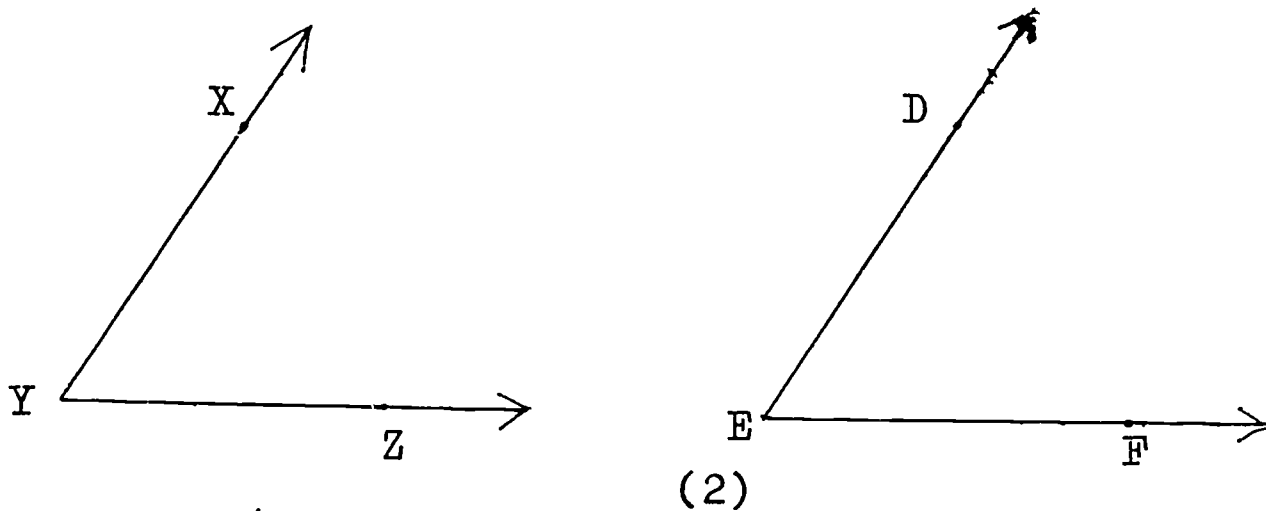

Trace $\angle XYZ$ onto tracing paper. Try to fit the tracing of $\angle XYZ$ onto $\angle DEF$. Place point Y of the tracing on point E with \overrightarrow{YZ} falling along \overrightarrow{EF} . Does \overrightarrow{YX} fall along \overrightarrow{ED} ? Do the two angles fit exactly? Is $\angle XYZ$ congruent to $\angle DEF$?

Measure $\angle XYZ$ and $\angle DEF$ with your protractor. What is true of these measures? Notice that $m \angle XYZ = m \angle DEF$.

If two angles are congruent, then they have equal measures.
 Also, if two angles have equal measures, then they are congruent.

- (1) Congruent line segments have equal measures.
 (2) Congruent angles have equal measures.

Exercises 3-2

1. Use your compass or dividers to decide which of the following segments are congruent to each other.

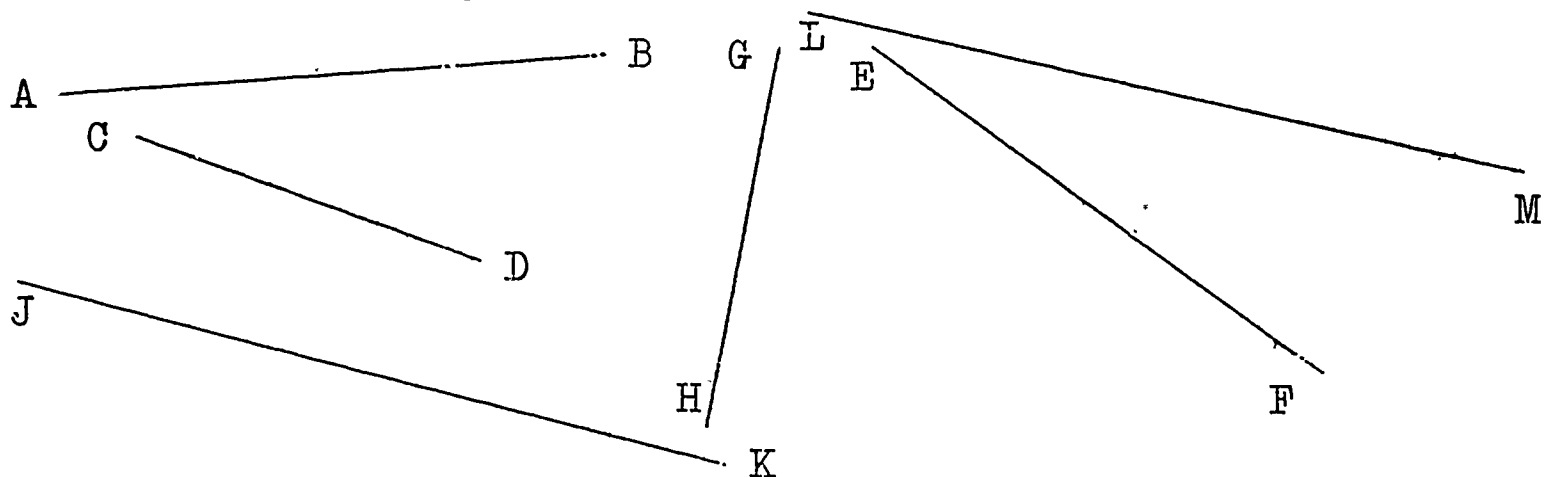

2. Check your answers to Exercise (1) by measuring the segments.
 3. Trace each of these angles on thin paper, and cut out the interiors. By fitting one angle onto another, decide which angles are congruent.

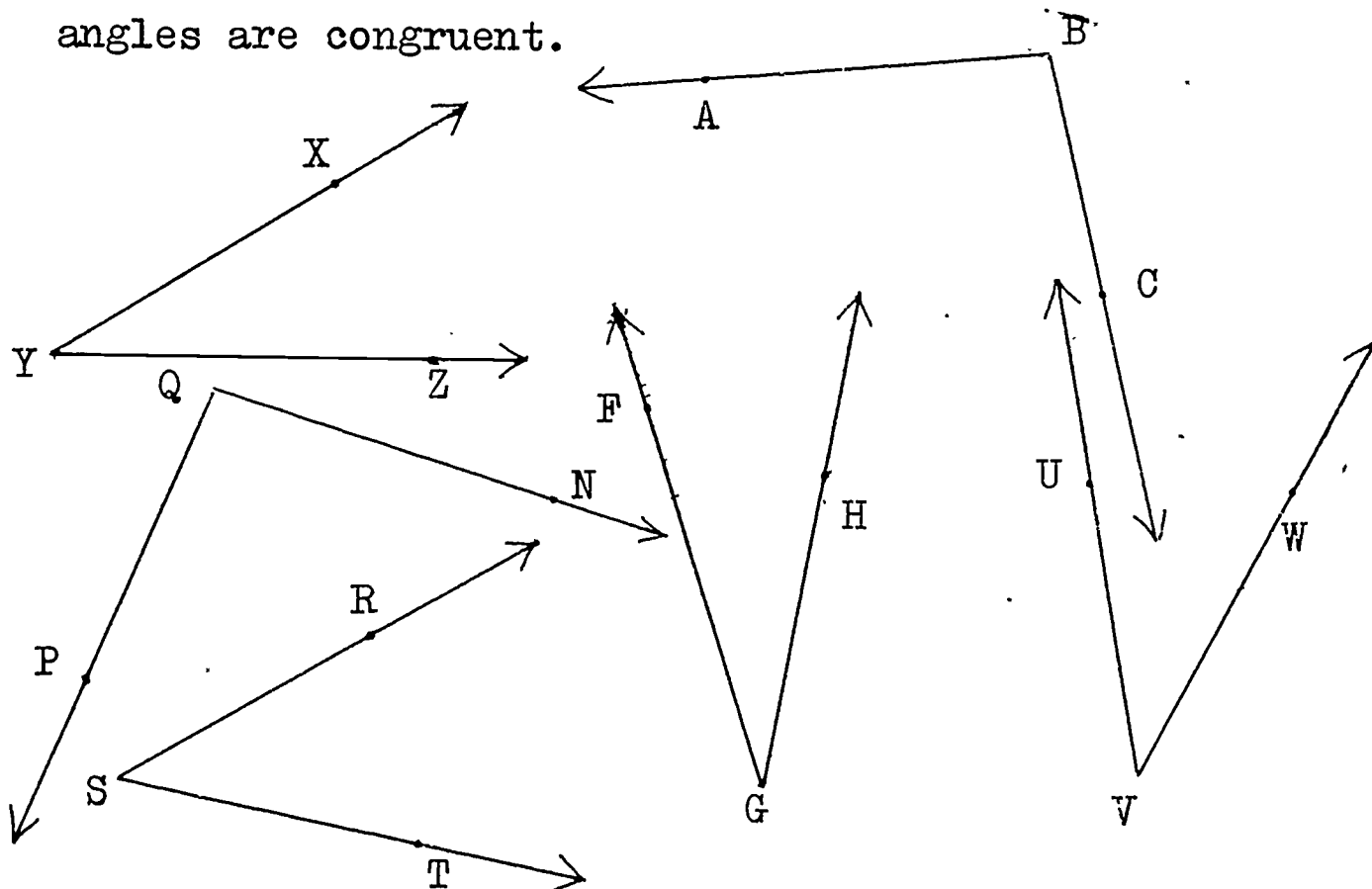

4. Check your answers in Exercise (3) by measuring the angles.
5. By tracing each of these plane figures on thin paper and cutting out their interiors, decide which are congruent:

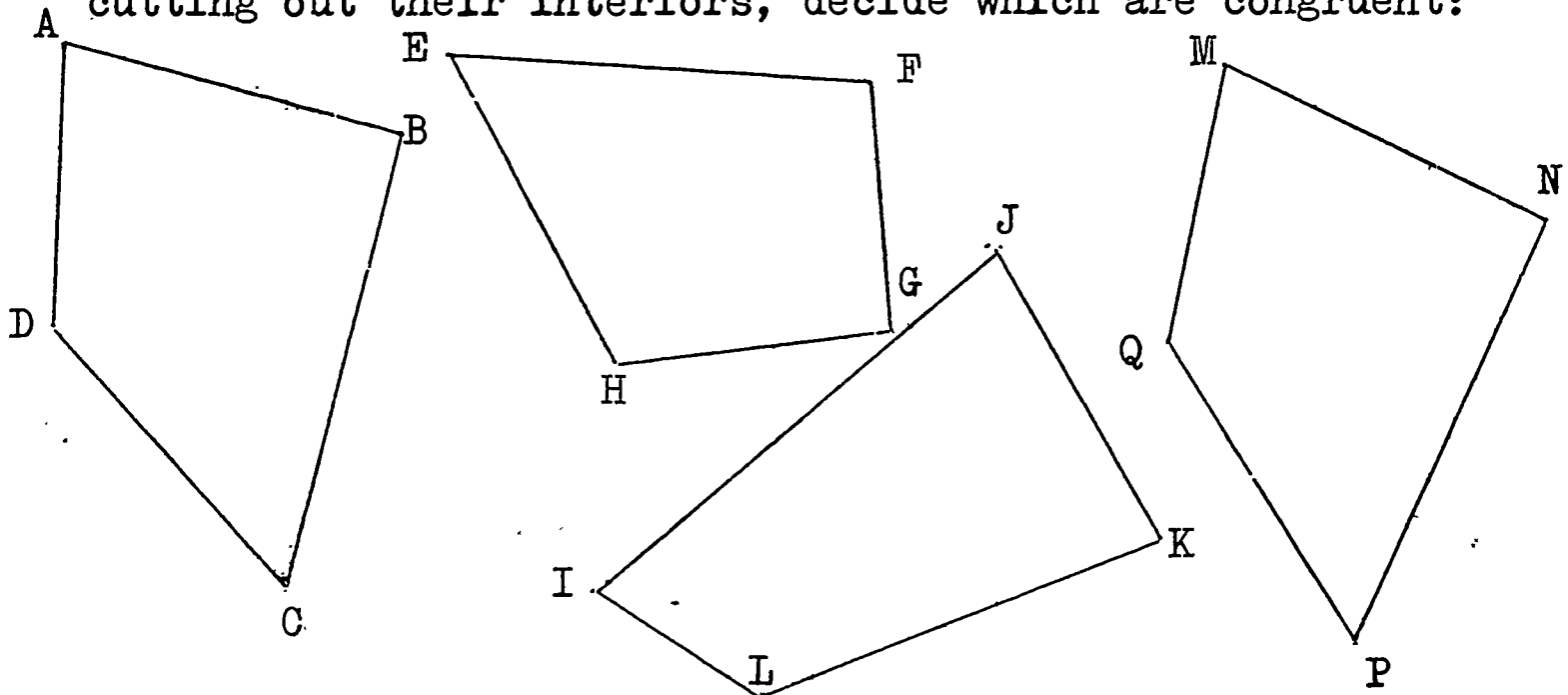

6. a. All right angles have measure of _____ .
- b. What is true about the measures of any two right angles ?
- c. Any two right angles are _____ .

3-3 Congruent Figures

Look at these two polygons:

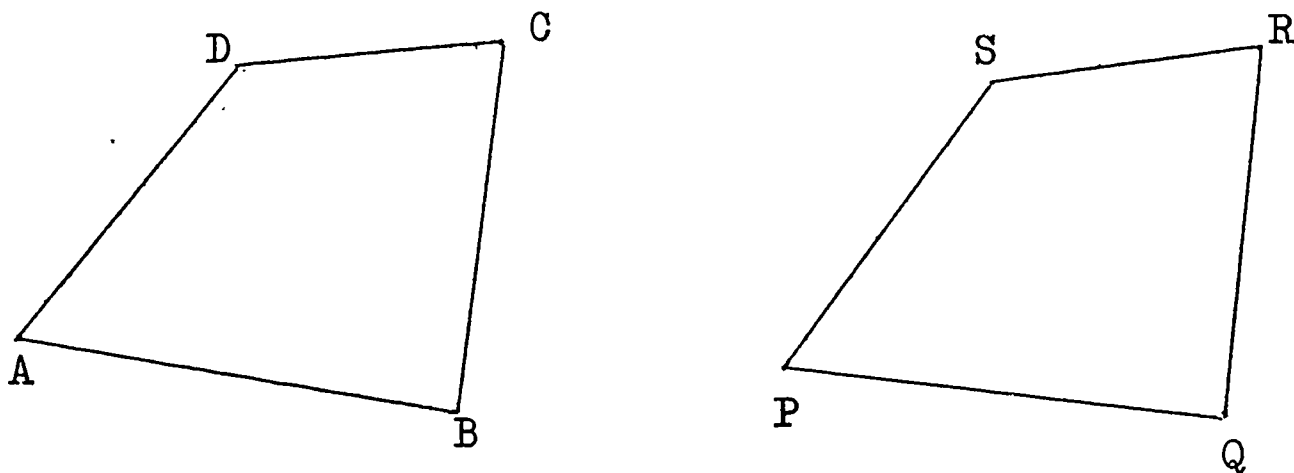

(1)

Carefully trace ABCD onto tracing paper. Place your tracing onto PQRS so that point A is on point P, B on Q, C on R and D on S. Do the two figures fit exactly ? Yes. We know then that polygon ABCD is congruent to polygon PQRS.

We write: $ABCD \equiv PQRS$.

Notice that point A corresponds to point P, B corresponds to Q, C corresponds to R, and D corresponds to point S.

We write the letters in the order of their correspondence:

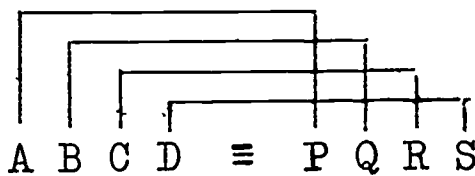

Now draw two circles, each of radius 5 cms., in your notebook. Call the centre points A and B. Trace circle A on thin paper. Place the tracing of A so that its centre point is on B. The two circles fit exactly. The circles are congruent. Is circle A also congruent to circle B? Do you think that two circles of radius 3 inches are congruent? Are any two circles of the same radius congruent?

Exercises 3-3

1. Which of the following are pairs of congruent figures? Make a tracing of one figure, then try to fit the tracing to the other figure.

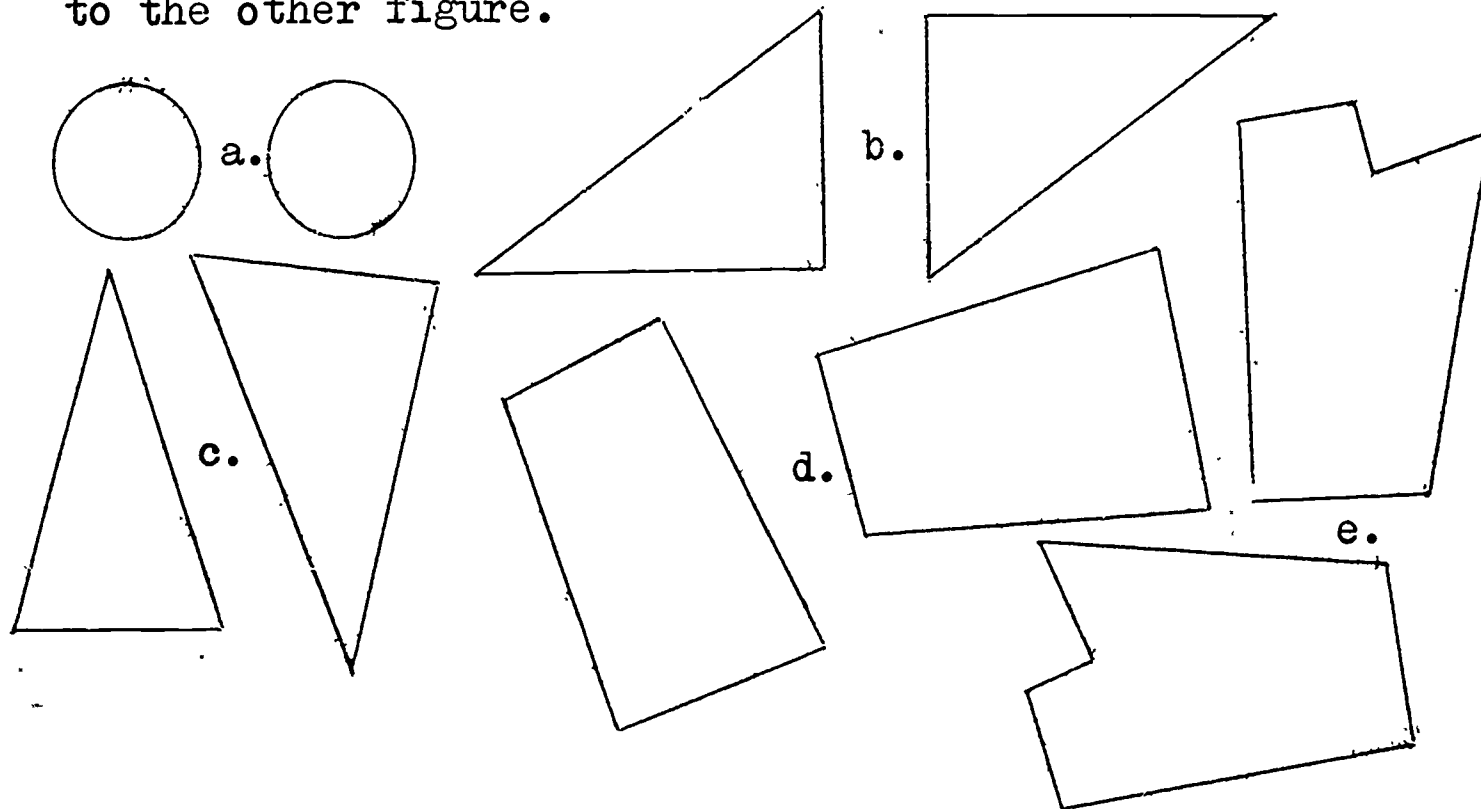

2. Where possible, match pairs of congruent figures by tracing one figure on a piece of paper and placing the tracing on the other figure:

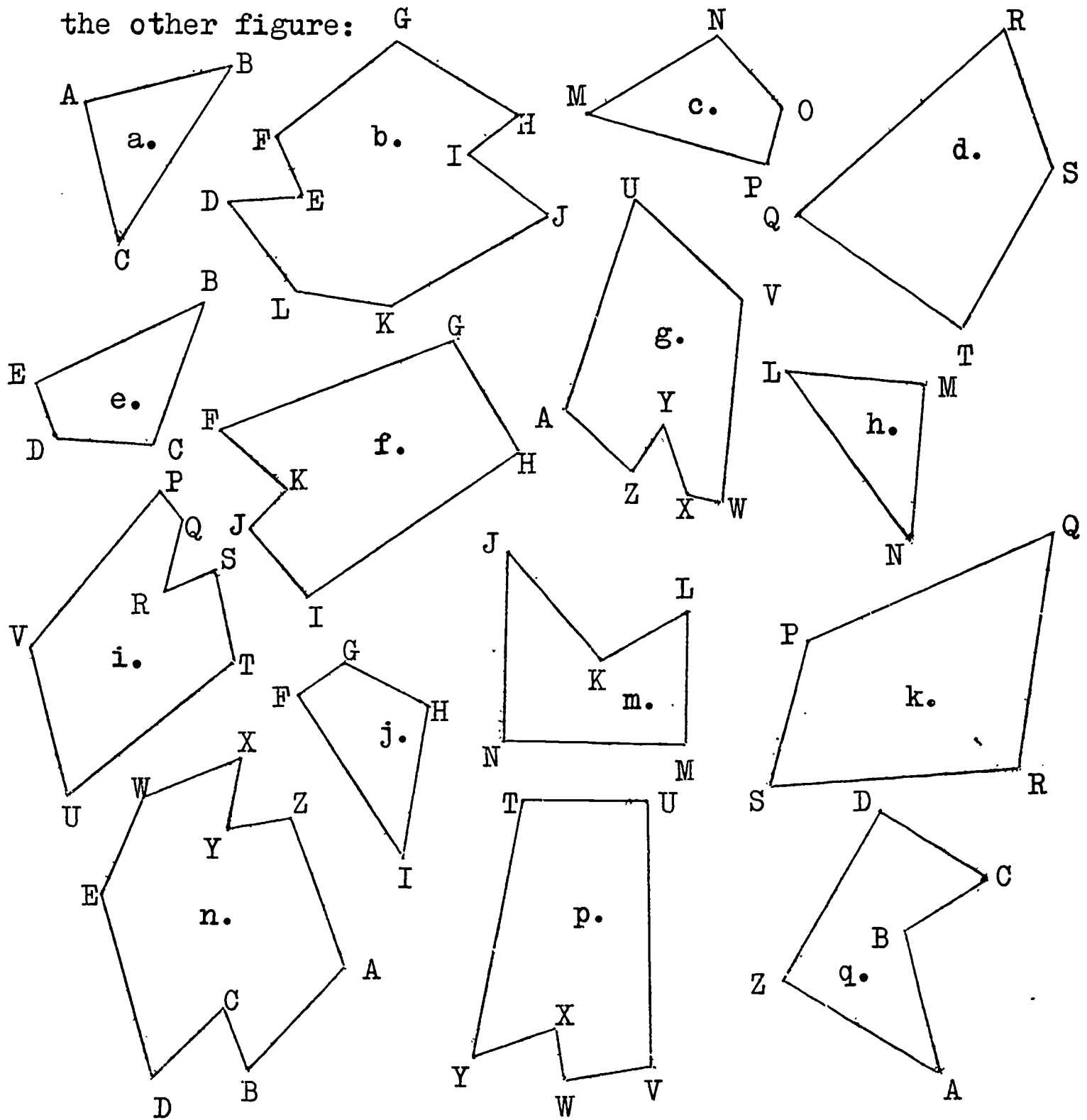

3. For each congruent pair in Exercise (2), write the congruence showing the correspondence of vertices.

4. Which of the following are pairs of congruent figures ?
Make a drawing to help you decide.

- Two line segments which have the same length.
- Two rectangles which have equal bases.
- Square ABCD and square RSTU, where $m \overline{RS} = m \overline{AB}$.
- Two rhombuses EFGH and KLMN, where $m \overline{FG} = m \overline{LM}$,
 $m \angle E = 60$ and $m \angle K = 35$.
- Two circles with equal radii.
- Two angles with equal measures.
- Parallelograms RSTU and WXYZ, where $m \overline{RS} = m \overline{WX}$,
 $m \angle T = 50$ and $m \angle Y = 50$.

3-4 Congruent Triangles

Look at these two triangles:

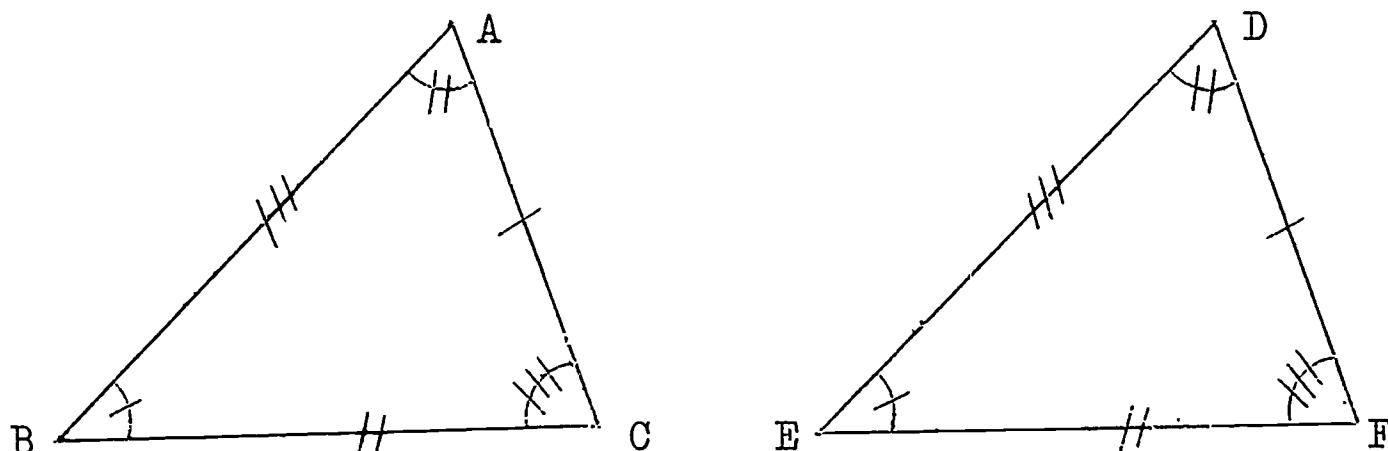

(1)

The marks on figure (1) tell us that:

$$\begin{array}{ll}
 m \angle A = m \angle D & m \overline{AB} = m \overline{DE} \\
 m \angle B = m \angle E & \text{and } m \overline{AC} = m \overline{DF} \\
 m \angle C = m \angle F & m \overline{BC} = m \overline{EF}
 \end{array}$$

Since the corresponding angles have the same measure in (1), and the corresponding sides have the same measure in (1),

we may then write:

$$\begin{array}{ll} \angle A \cong \angle D & \overline{AB} \cong \overline{DE} \\ \angle B \cong \angle E & \text{and } \overline{AC} \cong \overline{DF} \\ \angle C \cong \angle F & \overline{BC} \cong \overline{EF} \end{array}$$

(I)

The three angles of $\triangle ABC$ are congruent to the corresponding three angles of $\triangle DEF$. The three sides of $\triangle ABC$ are congruent to the corresponding three sides of $\triangle DEF$. Therefore, $\triangle ABC$ is congruent to $\triangle DEF$. We write:

$$\triangle ABC \cong \triangle DEF .$$

The triangles ABC and DEF are congruent when all of their corresponding parts are congruent.

Two triangles are congruent if all of their corresponding parts are congruent.

When we write $\triangle ABC \cong \triangle DEF$, we mean that the six corresponding parts in (I) above are congruent.

When you write the correspondence of $\triangle ABC$ and $\triangle DEF$ correctly as $\triangle ABC \cong \triangle DEF$, you can immediately decide on the correct correspondence of the angles and sides. Study the diagram on the next page, and you will see how easily this can be done.

$$\triangle \textcircled{A} B C \equiv \triangle \textcircled{D} E F$$

$$\underline{\angle A \equiv \angle D}$$

$$\triangle \underline{A B C} \equiv \triangle \underline{D E F}$$

$$\underline{\overline{AB} \equiv \overline{DE}}$$

$$\triangle A \textcircled{B} C \equiv \triangle D \textcircled{E} F$$

$$\underline{\angle B \equiv \angle E}$$

$$\triangle A \underline{B C} \equiv \triangle D \underline{E F}$$

$$\underline{\overline{BC} \equiv \overline{EF}}$$

$$\triangle A B \textcircled{C} \equiv \triangle D E \textcircled{F}$$

$$\underline{\angle C \equiv \angle F}$$

$$\triangle A B C \equiv \triangle D E F$$

$$\underline{\overline{AC} \equiv \overline{DF}}$$

Exercises 3-4

1. Determine whether each of the following pairs of triangles are congruent by measuring their corresponding parts.

Example:

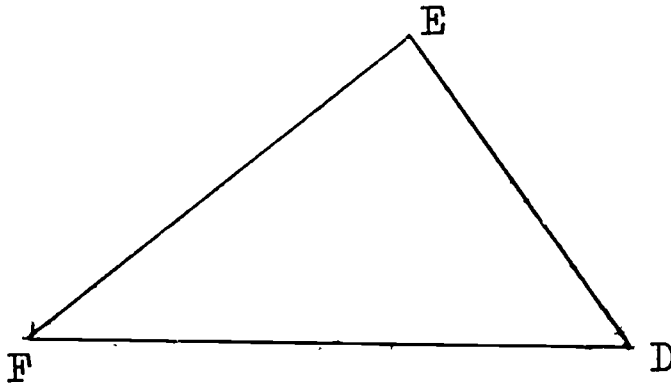
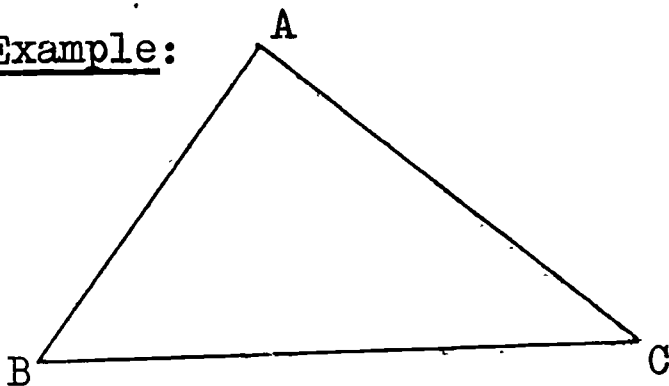

$$m \angle A = 90 : \angle A \equiv \angle E$$

$$m \angle E = 90$$

$$m \angle B = 52 : \angle B \equiv \angle D$$

$$m \angle D = 52$$

$$m \angle C = 38 : \angle C \equiv \angle F$$

$$m \angle F = 38$$

$$m \overline{AB} = 1.5 : \overline{AB} \equiv \overline{ED}$$

$$m \overline{ED} = 1.5$$

$$m \overline{BC} = 2.5 : \overline{BC} \equiv \overline{DF}$$

$$m \overline{DF} = 2.5$$

$$m \overline{AC} = 2.0 : \overline{AC} \equiv \overline{EF}$$

$$m \overline{EF} = 2.0$$

$$\triangle ABC \equiv \triangle EDF .$$

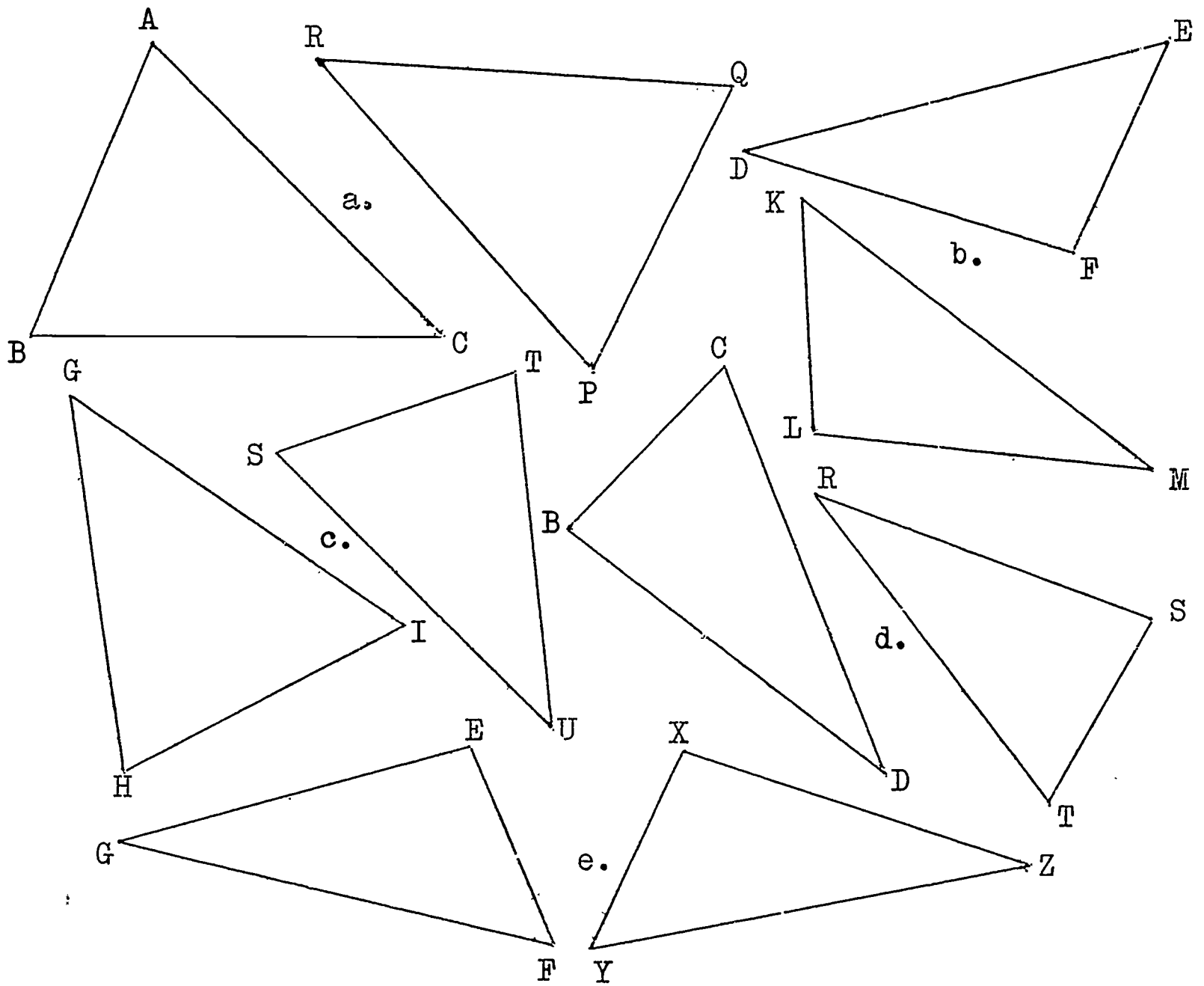

2. In each figure, there are two congruent triangles. List the pairs of corresponding sides and corresponding angles.

Example:

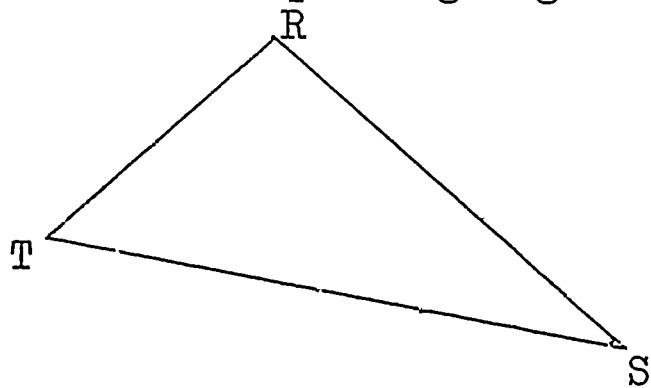
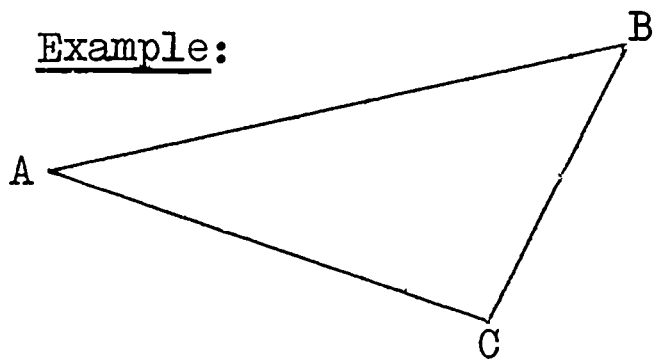

$$\angle A \cong \angle S$$

$$\angle B \cong \angle T$$

$$\angle C \cong \angle R$$

$$\overline{AB} \cong \overline{ST}$$

$$\overline{BC} \cong \overline{TR}$$

$$\overline{AC} \cong \overline{SR}$$

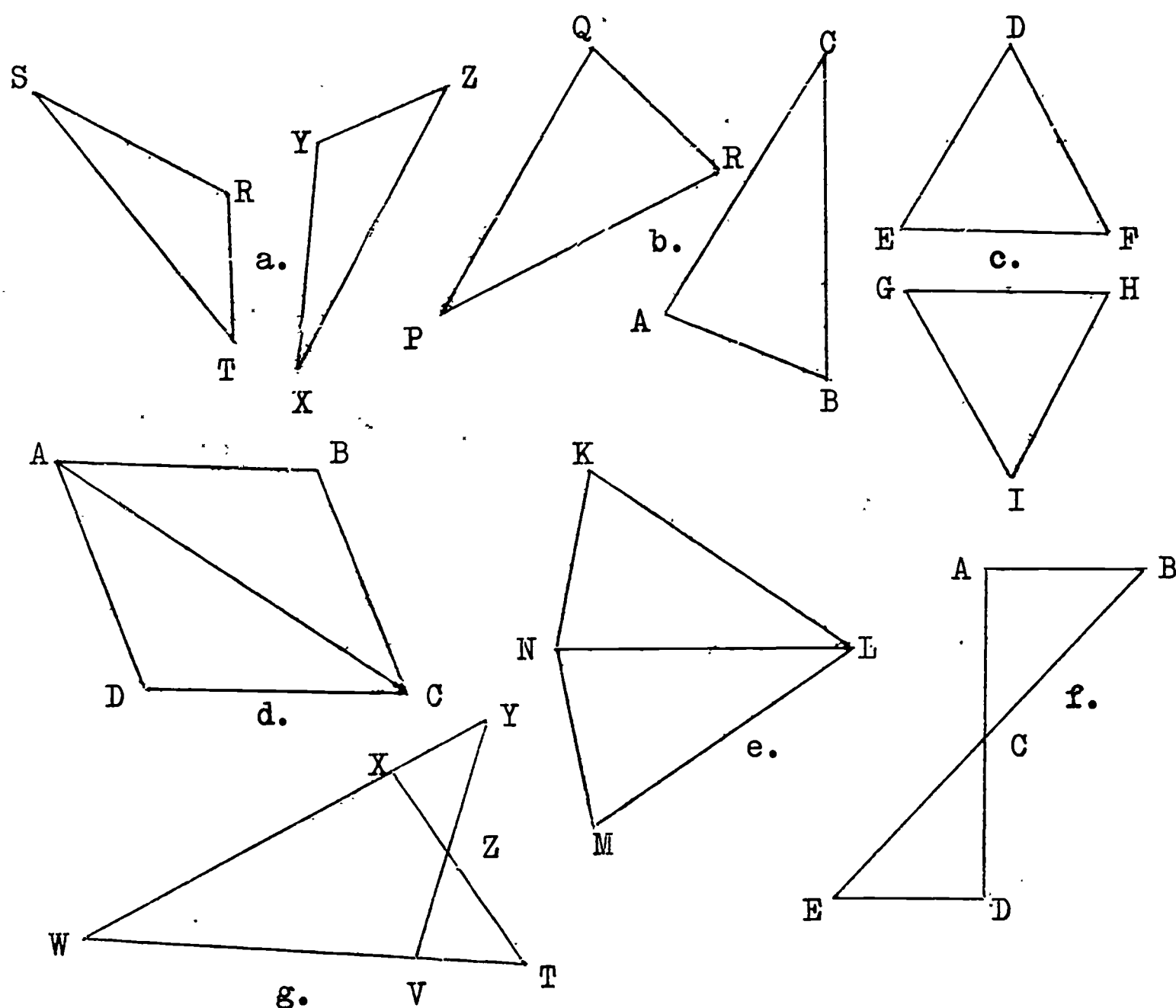

3-5 Congruence of Triangles: Two Sides and the Included Angle (SAS)

In Section 3-4, we found that triangles are congruent when all six of the corresponding parts are congruent.

Sometimes we can show that two triangles are congruent when three particular corresponding parts are given congruent.

You and your classmates will now conduct some experiments. You are to follow the directions given, and then you are to compare your results with your neighbour's. Let us call this:

Class Activity

1. On a piece of heavy paper, draw \overline{QR} 3 inches long.
2. With your protractor and ruler, draw \overrightarrow{QS} such that $m\angle RQS = 50$ (degrees).
3. Set your compass to a radius of 3.5 inches. With centre at Q, draw an arc on \overrightarrow{QS} , intersecting \overrightarrow{QS} at P.
4. Draw \overline{PR} .
5. Cut out $\triangle PQR$ with scissors or a razor.
6. Place your triangle PQR onto this triangle ABC:

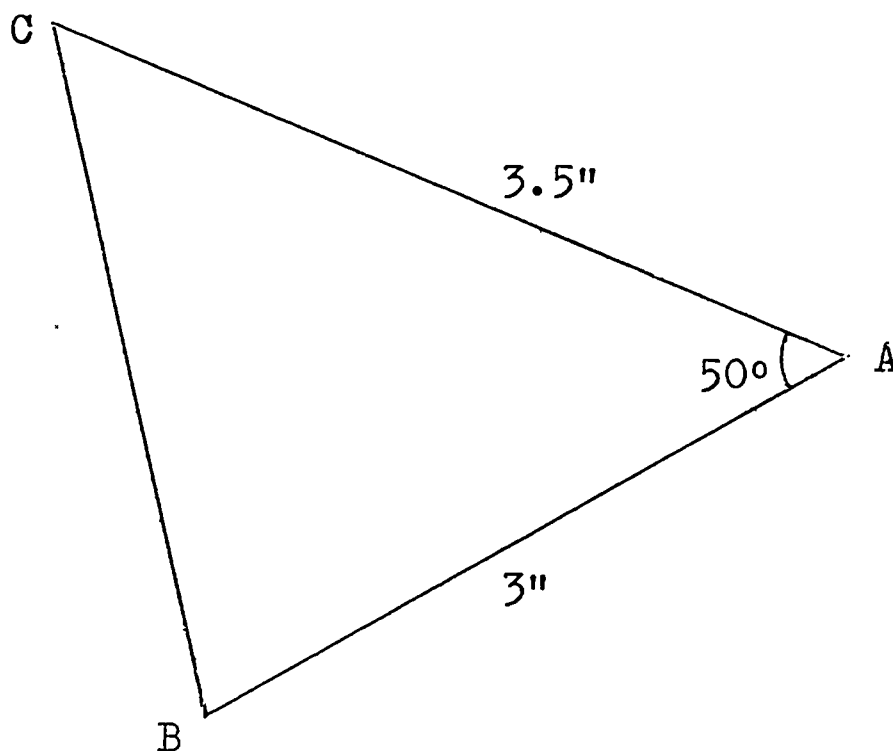

7. Do the two triangles fit exactly? Are the two triangles congruent?
8. Place your triangle PQR on top of your neighbour's $\triangle PQR$. Do they fit exactly? Are they congruent?

.....

What information did you have in constructing your

triangle PQR above ? You knew:

$$\begin{aligned} m \overline{QR} &= 3.0 \text{ (inches)} \\ m \angle Q &= 50 \text{ (degrees)} \\ m \overline{QP} &= 3.5 \text{ (inches)} \end{aligned}$$

But from only these three pieces of information, you made a triangle which was congruent to your neighbour's !

Notice that the three pieces of information from which you made $\triangle PQR$ were two sides and the included angle. The included angle is the angle formed by the two sides. Do you think that if you cut out another triangle in which you measured two sides and the included angle, that your triangle would be congruent to your neighbour's ? Check by doing Steps 1 - 5 again for $\triangle TRS$, in which:

$$\begin{aligned} m \overline{TR} &= 6 \text{ (cms.)} \\ m \angle R &= 115 \\ m \overline{RS} &= 9 \text{ (cms.)} \end{aligned}$$

We can conclude that if two triangles have:

(1) two corresponding sides congruent

and

(2) the angle included by these corresponding sides congruent,

then the two triangles are congruent.

This case of congruent triangles is called Side-Angle-Side. We abbreviate to SAS.

If two sides and the included angle of one triangle are congruent to the corresponding two sides and the included angle of another triangle, then the two triangles are congruent. (SAS)

Exercises 3-5

1. a. Which angle is included between \overline{AC} and \overline{AB} ?
- b. Which angle is included between \overline{AC} and \overline{BC} ?
- c. Between what two sides is $\angle CBA$ included ?
- d. Name the two angles not included between \overline{AB} and \overline{BC} .

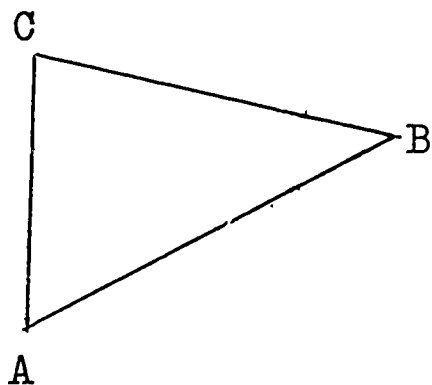

2. In the following pairs of triangles, some congruent sides and angles are marked. In each case, decide if SAS can be used to determine congruency of the triangles.

Example:

$$\overline{TS} \equiv \overline{ZX}$$

$$\angle T \equiv \angle Z$$

$$\overline{TR} \equiv \overline{ZY}$$

$$\triangle RST \equiv \triangle YXZ \text{ by SAS}$$

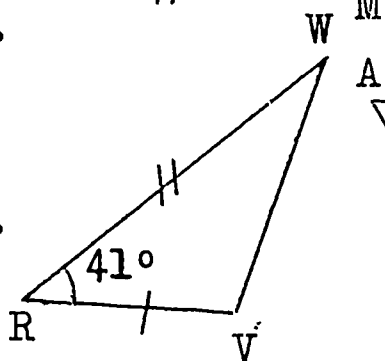
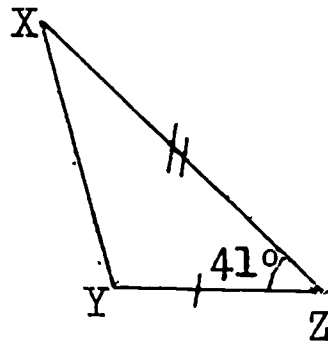
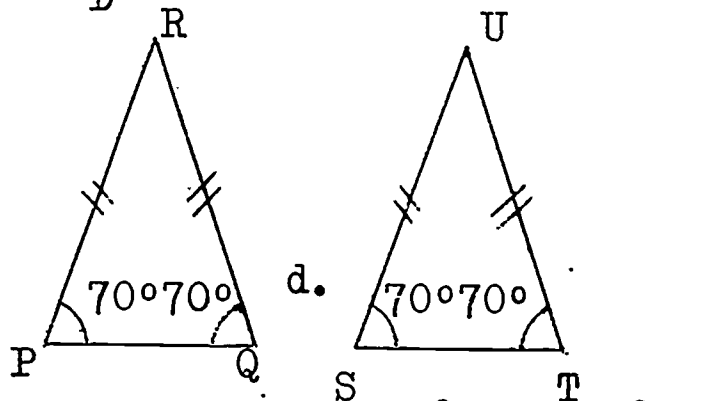
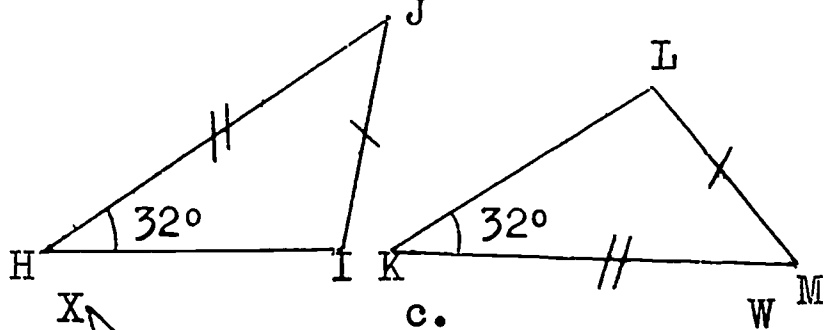
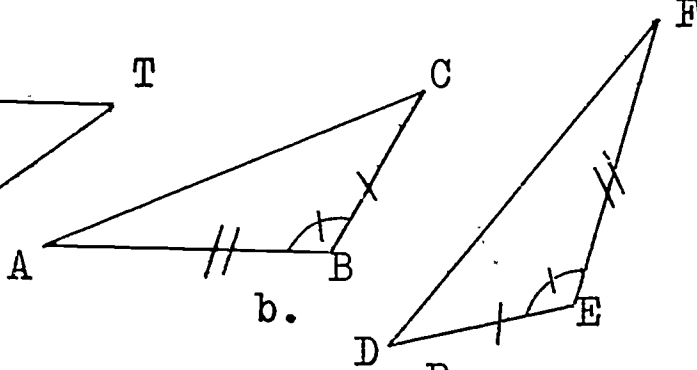
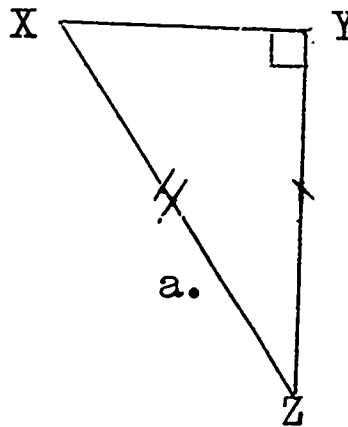
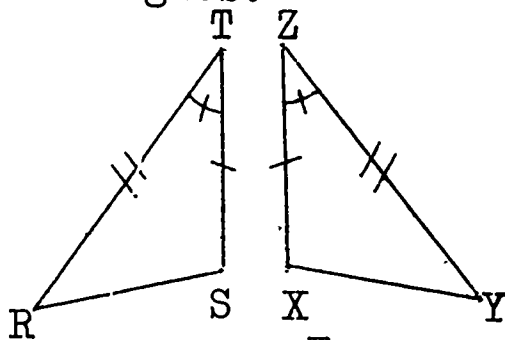

(can you find $m\hat{R}$ and $m\hat{U}$?)

3. ABCD is a parallelogram.

- a. $\angle a \equiv \angle b$ Why?
 $\overline{DC} \equiv \overline{BA}$ Why?
 $\overline{DB} \equiv \overline{BD}$ Why?

Is $\triangle ABD \equiv \triangle CDB$? Why?

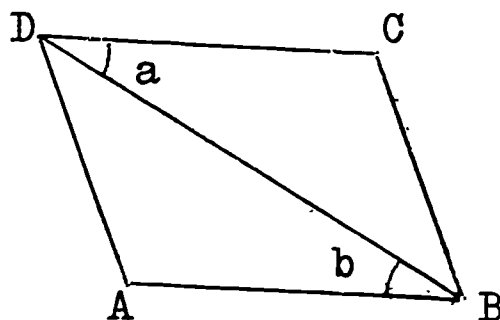

b. RSTU is a parallelogram.

- $\angle c \equiv \angle d$ Why?
 $\overline{UR} \equiv \overline{ST}$ Why?
 $\overline{US} \equiv \overline{SU}$ Why?

Is $\triangle RSU \equiv \triangle TUS$? Why?

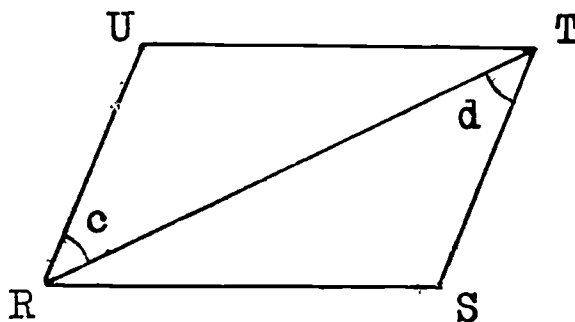

4. a. \overline{AD} and \overline{BC} bisect each other at E.

- $\overline{AE} \equiv \overline{DE}$ Why?
 $\angle a \equiv \angle b$ Why?
 $\overline{CE} \equiv \overline{BE}$ Why?

Is $\triangle ABC \equiv \triangle DCE$? Why?

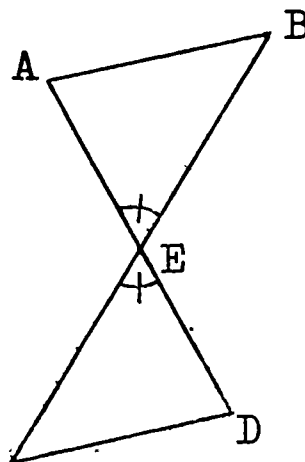

b. \overline{US} and \overline{VR} are segments intersecting at T such that $\overline{UT} \equiv \overline{RT}$ and $\overline{ST} \equiv \overline{VT}$.

Is $\triangle RST \equiv \triangle UVT$? Why?

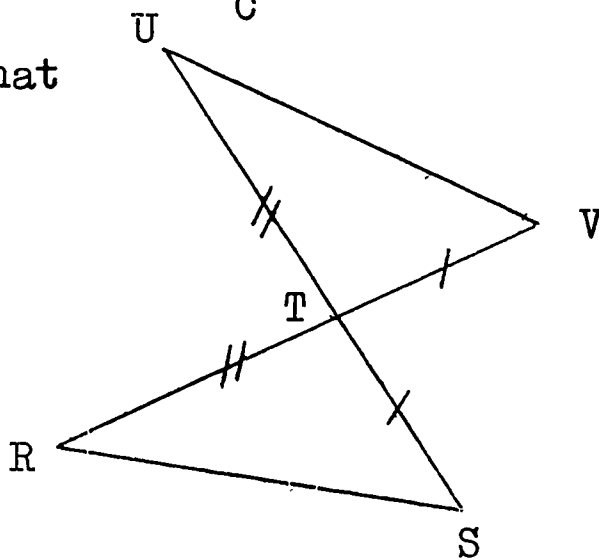

3-6 Congruence of Triangles: Three Sides (SSS)

In Section 3-5, you learnt that if two sides and the included angle of one triangle are congruent to the corresponding two sides and the included angle of another triangle, then the two triangles are congruent.

Are there three other pieces of information beside SAS which will also give us triangles which are congruent? Let us investigate this question in the following:

Class Activity

1. On a piece of heavy paper, draw \overline{KL} 4 inches long.
2. Open your compass to a radius of 2.5 inches. With centre at K, draw an arc on one side of \overline{KL} .
3. Now open your compass to a radius of 3 inches. With centre at L, draw another arc, intersecting the first arc at point M.
4. Draw \overline{MK} and \overline{ML} .
5. Cut out $\triangle KLM$ with scissors or a razor.
6. Place your $\triangle KLM$ onto $\triangle DEF$: 4"

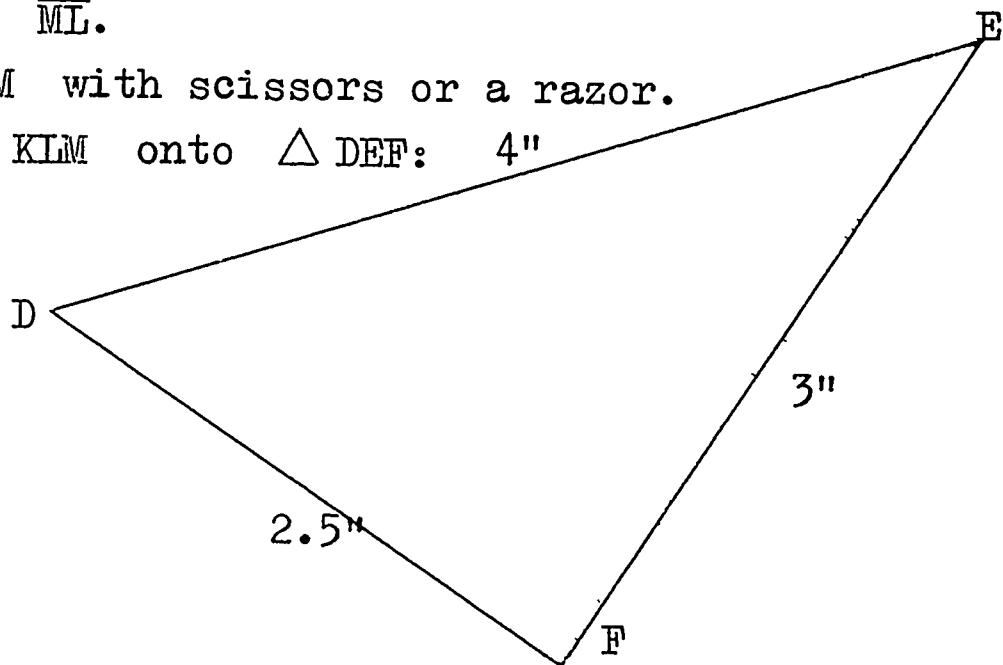

7. Do the two triangles fit exactly? Are they congruent?
8. Place your $\triangle KLM$ on top of your neighbour's $\triangle KLM$. Do they fit exactly? Are they congruent?

.....

What information did you have in constructing $\triangle KLM$ above ? You knew:

$$m \overline{KL} = 4 \text{ (inches)}$$

$$m \overline{LM} = 3 \text{ (inches)}$$

$$m \overline{KM} = 2.5 \text{ (inches)}$$

From these three pieces of information, you made a triangle which was congruent to your neighbour's. Notice that this time the three parts from which you made $\triangle KLM$ were the three sides.

Do you think that if you cut out another triangle in which you knew the measures of the three sides, that your triangle would be congruent to your neighbour's ? Check by doing Steps 1 - 5 for $\triangle XYZ$, in which:

$$m \overline{XY} = 5.6 \text{ (cms.)}$$

$$m \overline{YZ} = 11.3 \text{ (cms.)}$$

$$m \overline{XZ} = 9.1 \text{ (cms.)}$$

We can say that if two triangles have the three sides of one congruent to the corresponding three sides of the other, then the two triangles are congruent. We call this the Side-Side-Side case of congruent triangles, and abbreviate to SSS .

If three sides of one triangle are congruent to the corresponding three sides of another triangle, then the two triangles are congruent. (SSS)

Now look at these two triangles:

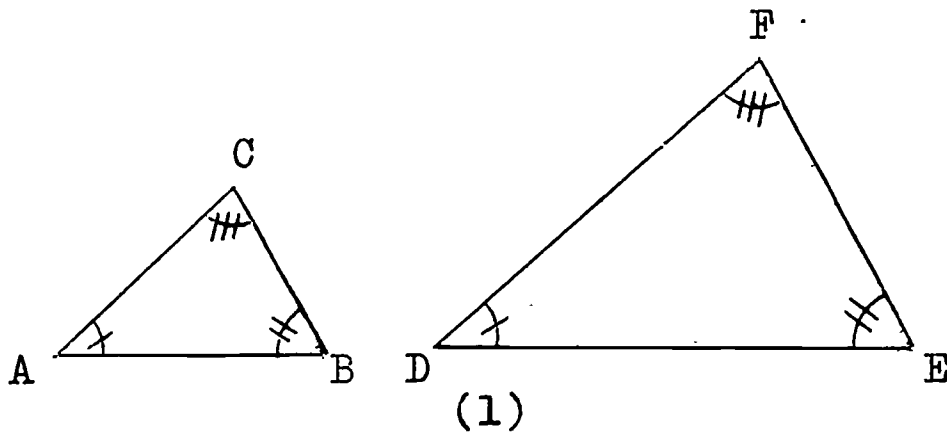

In figure (1), all corresponding angles are congruent. Are the two triangles congruent? Do you think there is an Angle-Angle-Angle case of congruent triangles? $\triangle ABC$ and $\triangle DEF$ in figure (1) have the same shape but they do not have the same size.

We realize that knowing any three pairs of corresponding parts of two triangles will not necessarily guarantee us congruency. We must be careful what three corresponding pairs are given to us when deciding whether or not two triangles are congruent.

Exercises 3-6

1. State whether or not each of the following pairs of triangles are congruent, and give your reason.

Example

$$\triangle ABC \cong \triangle XYZ ; SAS$$

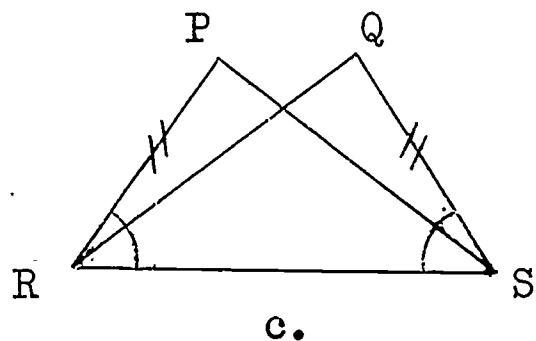
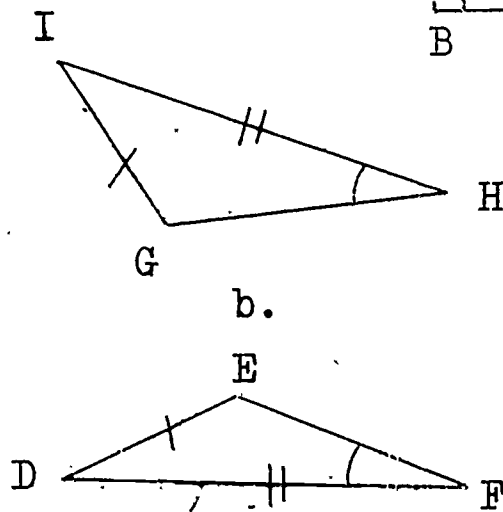
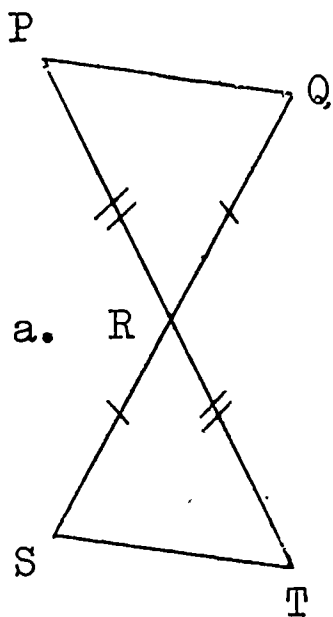
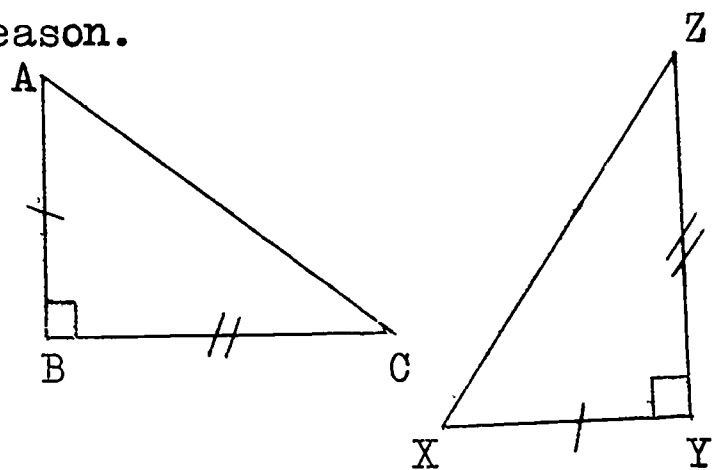

2. Given \overline{AB} and \overline{CD} bisecting each other at P .

- Is $\overline{AP} \cong \overline{BP}$? Why?
- Is $\overline{DP} \cong \overline{CP}$? Why?
- Is $\angle APD \cong \angle BPC$? Why?
- Is $\triangle APD \cong \triangle BPC$? Why?

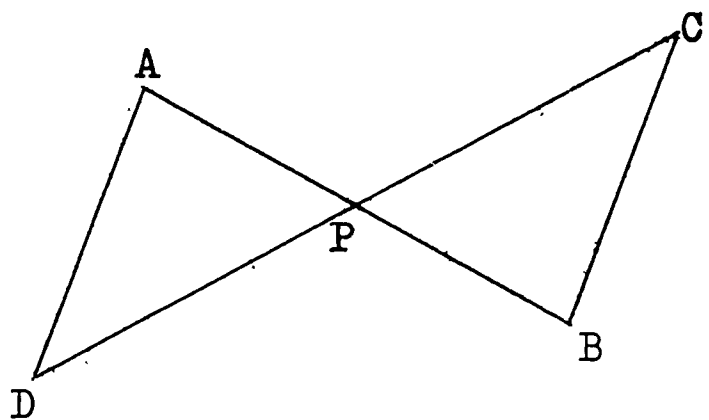

3. Given ABCD a parallelogram

- Is $\overline{DC} \cong \overline{BA}$? Why?
- Is $\overline{DB} \cong \overline{DB}$? Why?
- Is $\overline{AD} \cong \overline{CB}$? Why?
- Is $\triangle ABD \cong \triangle CDB$? Why?

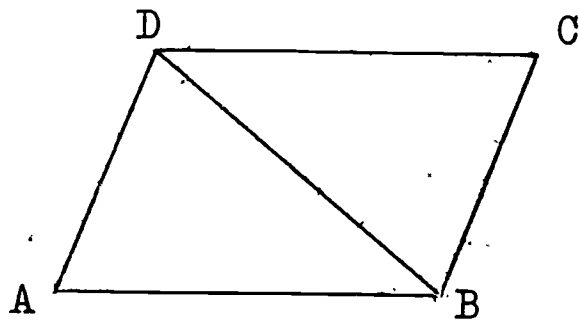

4. Given $\triangle ABC$ and $\triangle DEF$ in which the figures are marked.

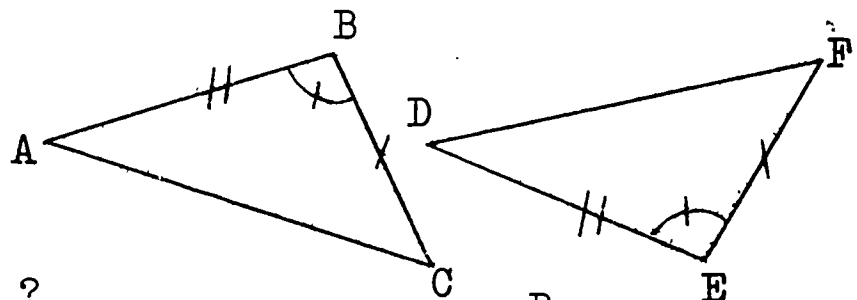

Is $\triangle ABC \cong \triangle DEF$? Why?

5. Given the figure in which $\overline{AD} \cong \overline{DC}$ and $\overline{BD} \perp \overline{AC}$.

- Is $\overline{AD} \cong \overline{CD}$? Why?
- Is $\angle ADB \cong \angle CDB$? Why?
- Is $\overline{BD} \cong \overline{BD}$? Why?
- Is $\triangle ABD \cong \triangle CBD$? Why?

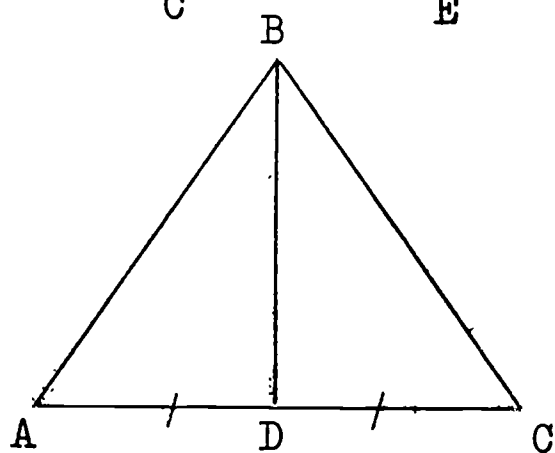

6. Given the figure in which

$\overline{AB} \cong \overline{CB}$ and $\overline{AD} \cong \overline{CD}$

- Is $\triangle ABD \cong \triangle CBD$? Why?
- Name the corresponding parts which you used to say that the triangles are congruent.

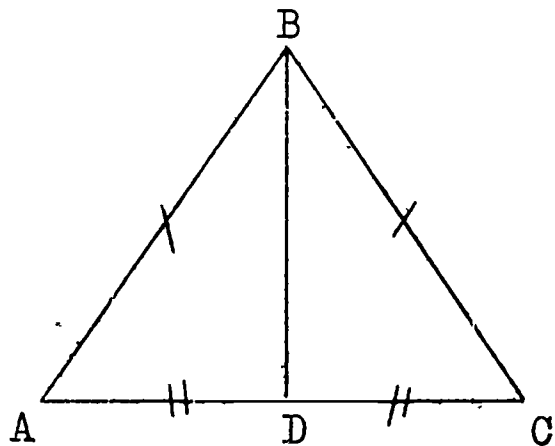

7. Given the figure in which $\overline{AB} \cong \overline{BC}$ and $\angle x \cong \angle y$.

- Is $\overline{AB} \cong \overline{CB}$? Why?
- Is $\angle x \cong \angle y$? Why?
- Is $\overline{BD} \cong \overline{BD}$? Why?
- Is $\triangle ABD \cong \triangle CBD$? Why?

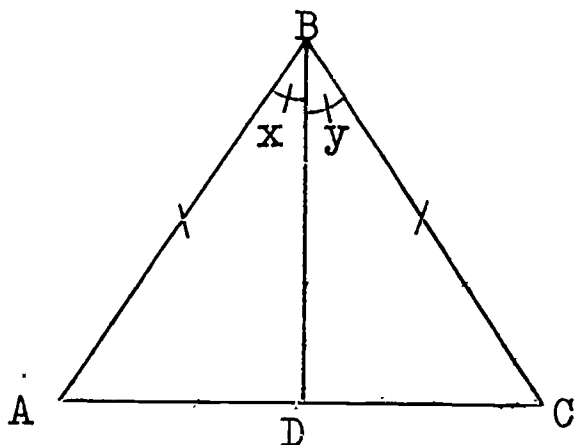

8. Given the figure in which $\angle x \cong \angle y$ and $\overline{RS} \cong \overline{RU}$.

- Is $\triangle RST \cong \triangle RUT$? Why?
- Name the corresponding parts which you used to say that the triangles are congruent.

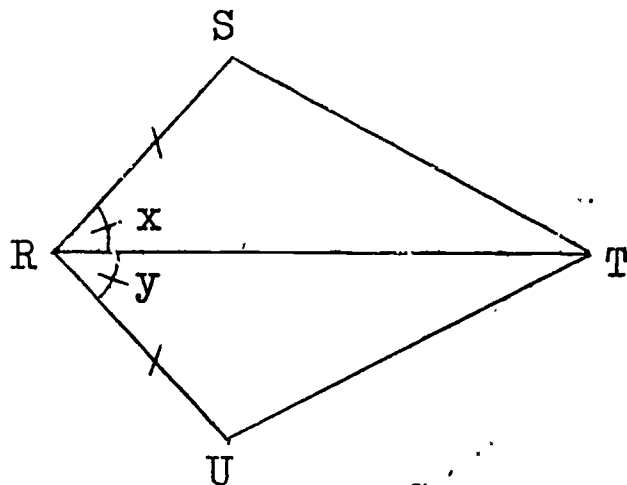

9. Given the figure in which $\overline{RS} \cong \overline{RU}$, $m\angle ST = 4$, $m\angle UT = 4$.

- Is $\triangle RST \cong \triangle RUT$? Why?
- Name the corresponding parts which you used to say that the triangles are congruent.

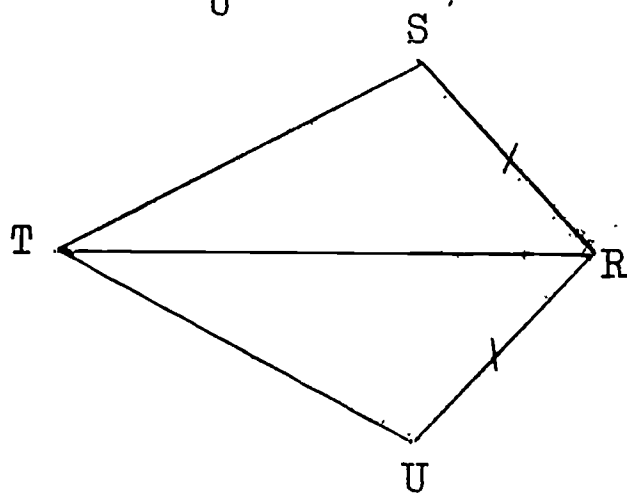

10. Given the figure in which Y is the midpoint of \overline{WZ} and $\overline{AY} \cong \overline{XY}$.

- Is $\triangle AYZ \cong \triangle XYW$? Why?
- Name the corresponding parts which you used to say that the triangles are congruent.

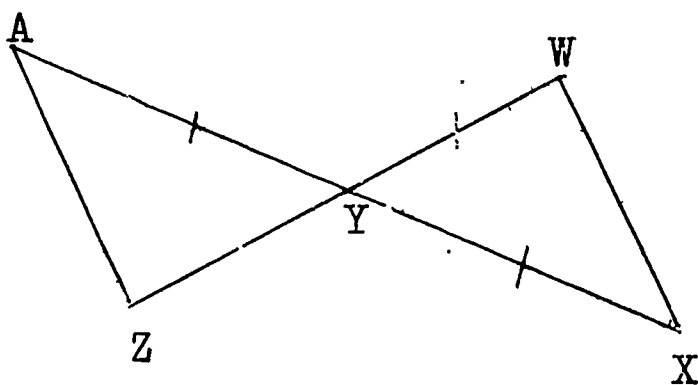

3-7 Congruence of Triangles: Two Angles and One Side
(ASA or AAS)

Let us now investigate another case of congruence of triangles in the following:

Class Activity

1. On a piece of heavy paper, draw \overline{BC} 3.5 inches long.
2. With your protractor and ruler, draw \overline{BD} such that $m\angle DBC = 50$.
3. Draw \overline{CE} so that $m\angle ECB = 60$.
4. Call the intersection of \overline{BD} and \overline{CE} point A.
5. Cut out $\triangle ABC$.
6. Place your $\triangle ABC$ onto this $\triangle GHI$:

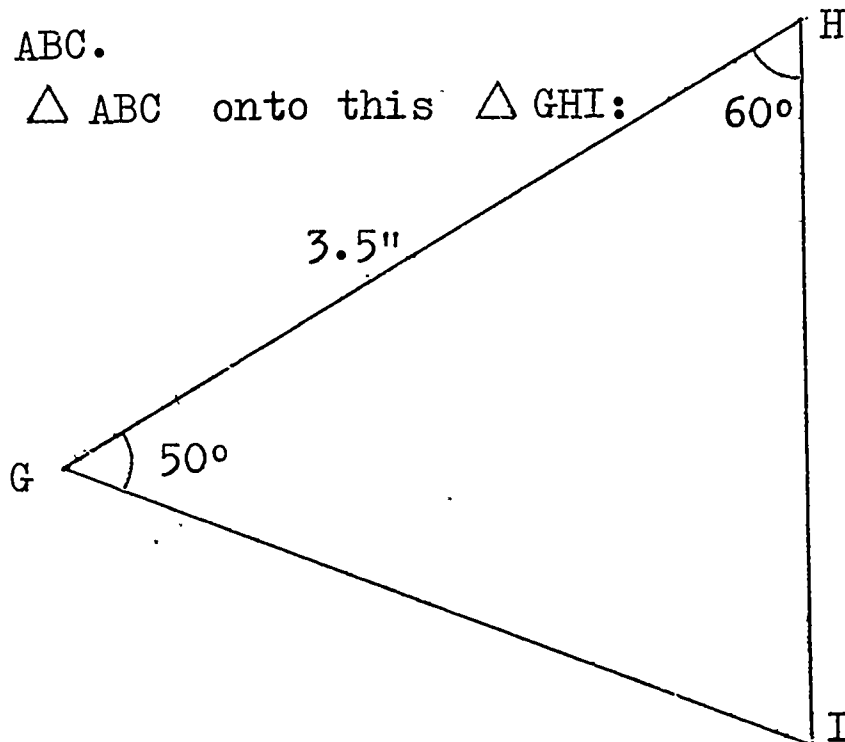

7. Do the two triangles fit exactly? Are they congruent?
8. Place your $\triangle ABC$ on top of your neighbour's $\triangle ABC$. Do they fit exactly? Are they congruent?

.....

What information did you have in constructing your $\triangle ABC$ above? You knew:

$$m \angle ABC = 50 \text{ (degrees)}$$

$$m \overline{BC} = 3.5 \text{ (inches)}$$

$$m \angle ACB = 60 \text{ (degrees)}$$

Notice that the three parts from which you made $\triangle ABC$ were two angles and the included side.

Repeat Steps 1-5 for $\triangle DEF$ in which:

$$m \angle D = 52 \text{ (degrees)}$$

$$m \overline{DE} = 7.0 \text{ (cms.)}$$

$$m \angle E = 73 \text{ (degrees)}$$

What is true about your $\triangle DEF$ and your neighbour's $\triangle DEF$?

If two triangles have two angles and the included side of one congruent to the corresponding two angles and the included side of the other, then the two triangles are congruent. We call this the Angle-Side-Angle case of congruent triangles, and abbreviate ASA.

If two angles and the included side of one triangle are congruent to the corresponding two angles and the included side of another triangle, then the two triangles are congruent. (ASA)

Look at these triangles:

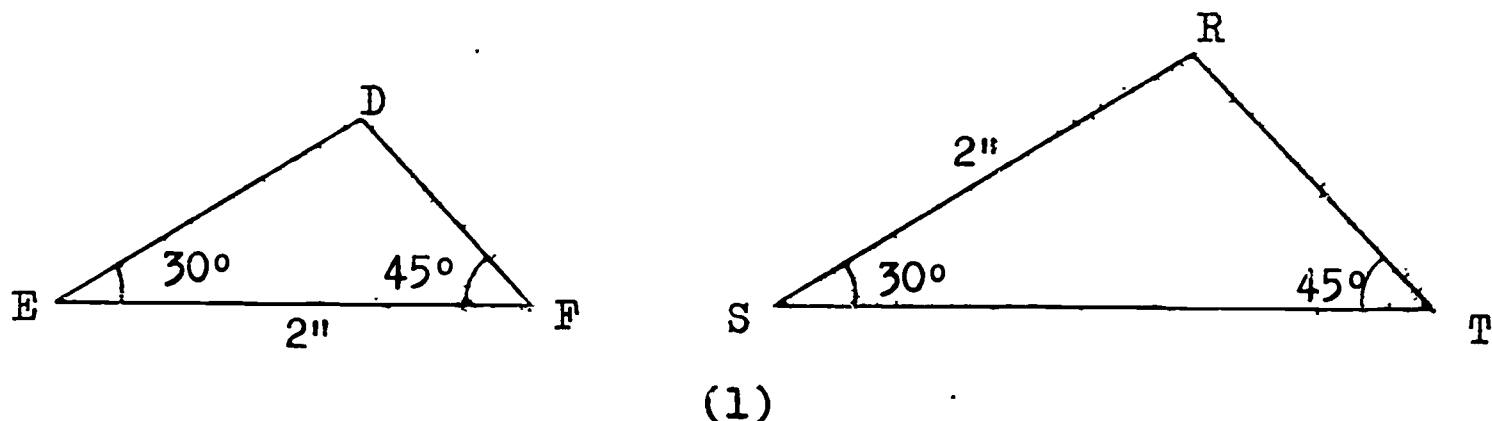

In figure (1), $m \overline{EF} = m \overline{SR}$. But \overline{EF} and \overline{SR} are not corresponding sides of the two triangles. What is the side of $\triangle SRT$ which corresponds with \overline{EF} ? Does \overline{ST} correspond with \overline{EF} ? Is $m \overline{EF} = m \overline{ST}$? Measure \overline{EF} and \overline{ST} to check. Is $\overline{EF} = \overline{ST}$? Is $\triangle EDF \cong \triangle SRT$? We realize that it is most important to have the corresponding sides of equal measures in order to have two triangles congruent.

Now look at these two triangles:

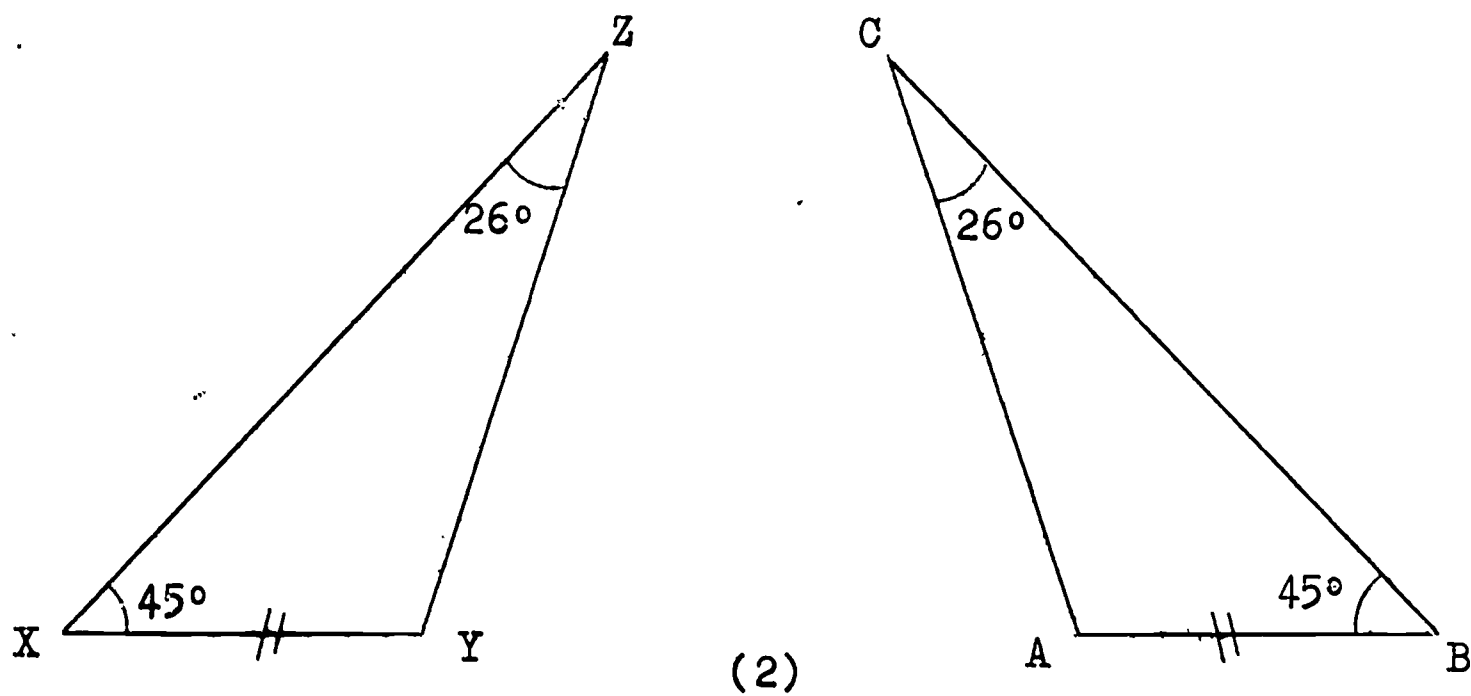

Notice in figure (2) on the previous page that the sides \overline{XY} and \overline{AB} are not included between the given angles.

However,

$$m \angle Y = 180 - (45 + 26) = 109$$

$$m \angle A = 180 - (45 + 26) = 109 .$$

Therefore,

$$\angle Y \equiv \angle A .$$

Are \overline{XY} and \overline{AD} now included between corresponding pairs of angles whose measures are known to be equal ?

Therefore,

$$\triangle XYZ \equiv \triangle BAC \quad \text{by ASA} .$$

We realize that when we know the measures of two angles of a triangle, we can always find the measure of the third angle.

We can then say that if two angles and a side of one triangle are congruent to the corresponding angles and a side of another triangle, then the two triangles are congruent. We call this case of congruent triangles Angle-Angle-Side, and abbreviate AAS.

If two angles and a side of one triangle are congruent to the corresponding two angles and a side of another triangle, then the two triangles are congruent. (AAS)

Exercises 3-7

1. Given the $\triangle RST$.

- Which side is included between $\angle T$ and $\angle S$?
- Which side is included between $\angle TRS$ and $\angle TSR$?
- Which two sides are not included between $\angle T$ and $\angle R$?

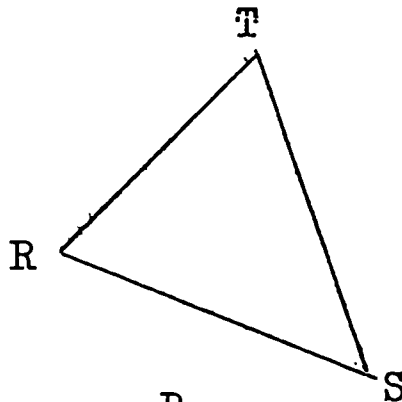

2. Given the figure in which

$$\overline{BC} \cong \overline{SR}, \angle B \cong \angle S, \angle C \cong \angle R.$$

- Is $\angle B \cong \angle S$? Why?
- Is $\angle C \cong \angle R$? Why?
- Is $\overline{BC} \cong \overline{SR}$? Why?
- Is $\triangle ABC \cong \triangle TSR$? Why?

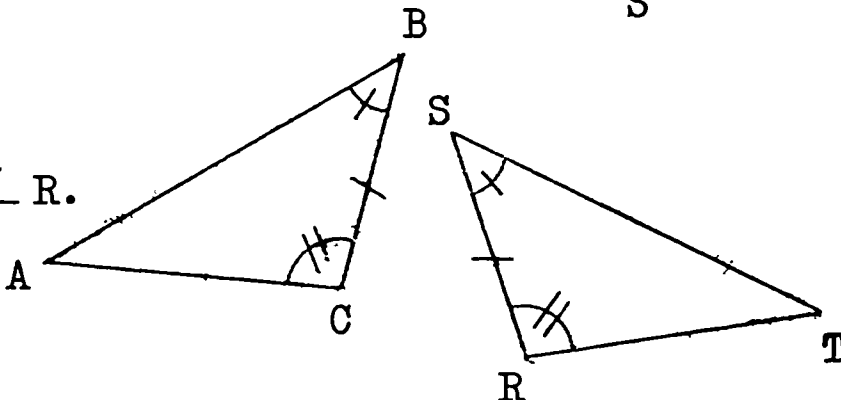

3. Given $\overline{UT} \parallel \overline{RS}$ and $\overline{UT} \cong \overline{RS}$.

- Is $\overline{UT} \cong \overline{SR}$? Why?
- Is $\overline{US} \cong \overline{UR}$? Why?
- Is $\angle a \cong \angle b$? Why?
- Is $\triangle UTS \cong \triangle SRU$? Why?

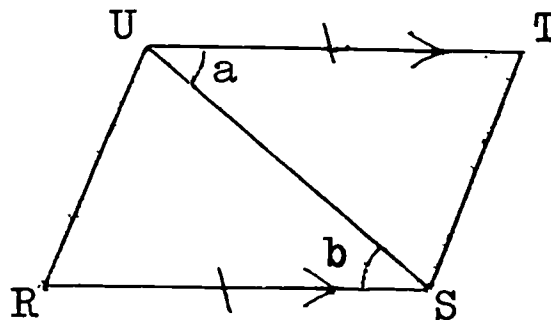

4. Given WXYZ a parallelogram.

- Is $\triangle WZX \cong \triangle YXZ$? Why?
- Name the corresponding parts which you used to say that the triangles are congruent.

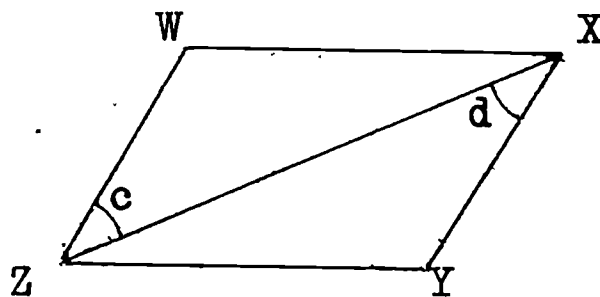

5. Given $\overline{DE} \parallel \overline{AB}$, C is the midpoint of \overline{BD} , and \overline{AE} and \overline{BD} are segments.

- Is $\triangle ABC \cong \triangle EDC$? Why?
- Name the corresponding parts which you used to say that the triangles are congruent.

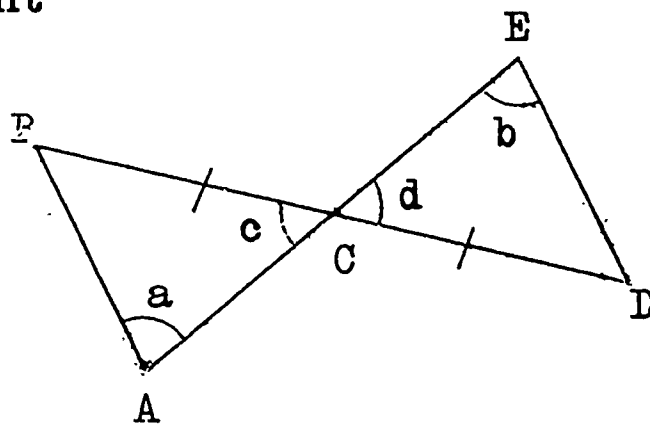

6. Write SSS, ASA, AAS, or SAS to indicate why the following pairs of triangles are congruent. If the pair is not congruent, write "Not congruent".

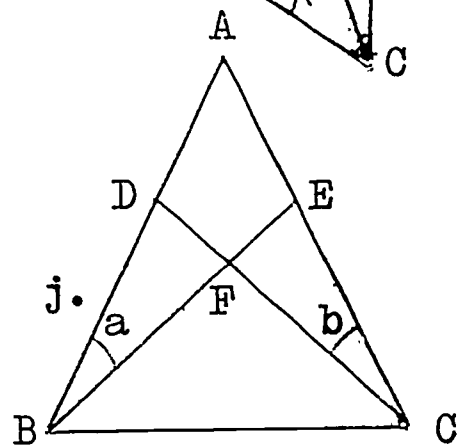
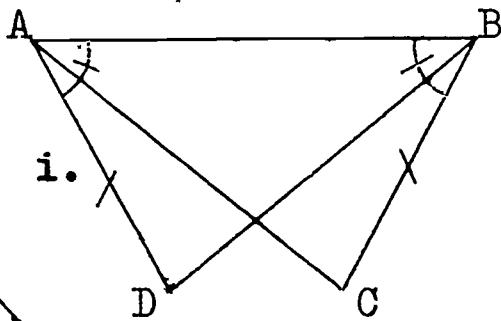
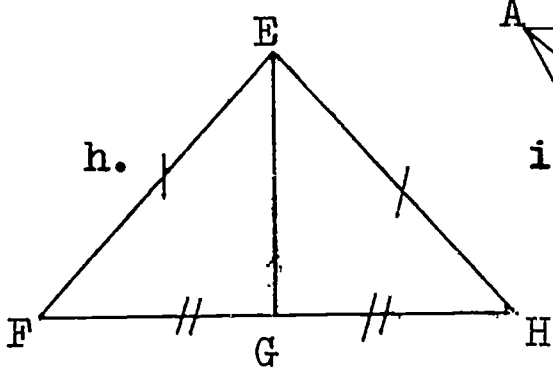
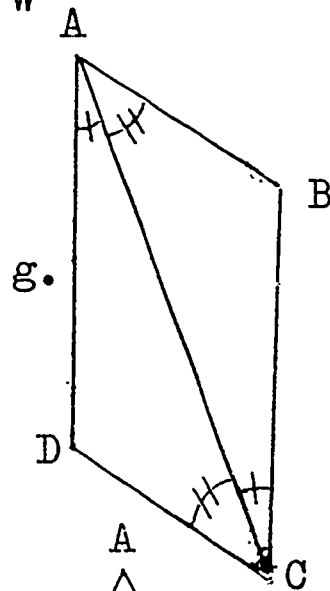
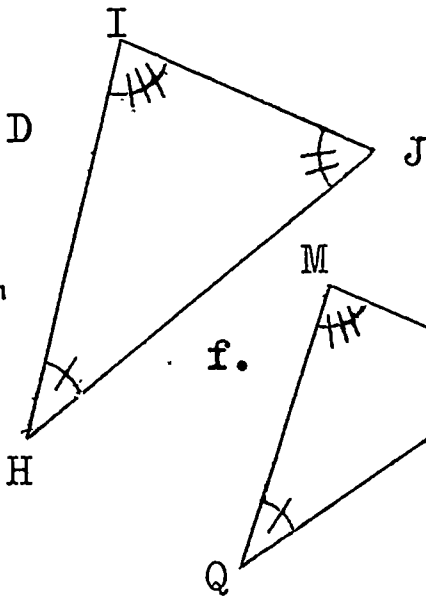
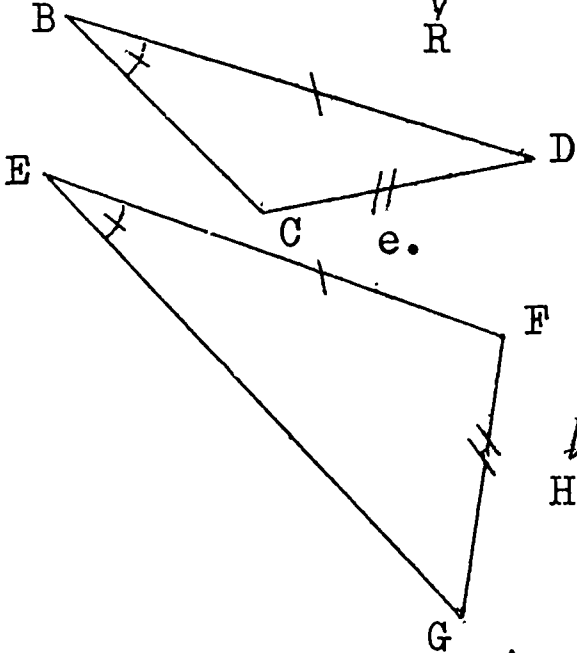
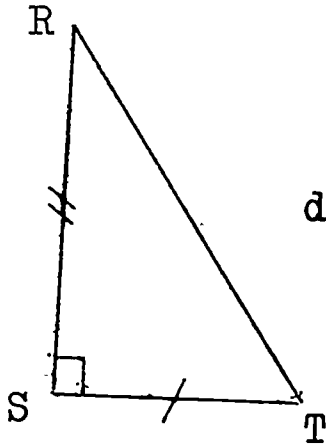
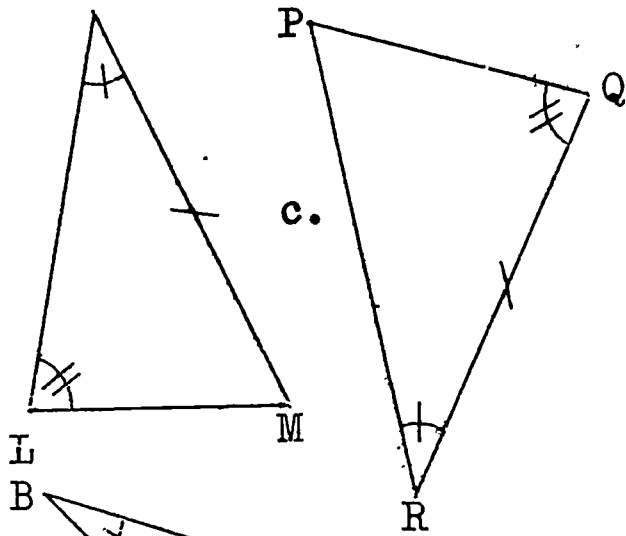
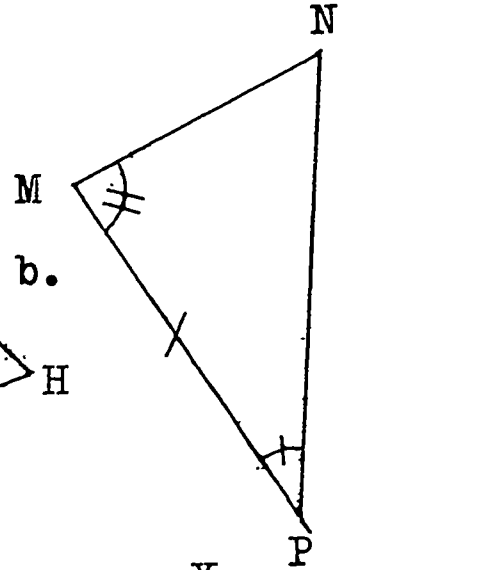
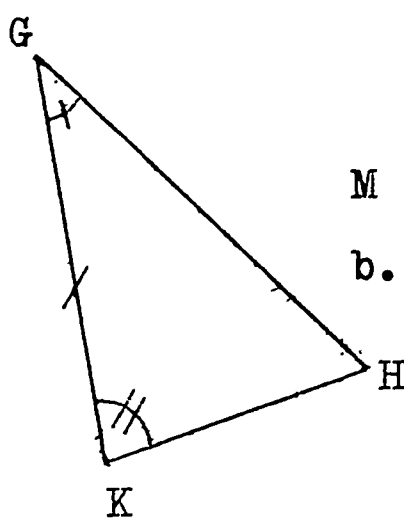
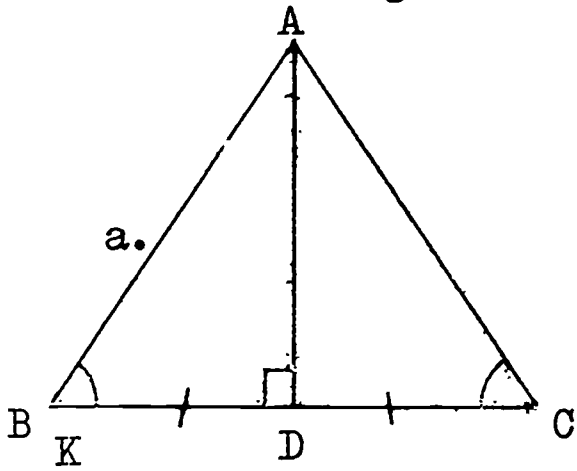

Is $\triangle ABC \cong \triangle BAD$?
Why?

$\overline{AB} \cong \overline{AC}$, $\angle a \cong \angle b$.
Is $\triangle ABE \cong \triangle ACD$?
Why?

7. In each of the following pairs of triangles, only two parts are given. State the third part in order to have the triangles congruent, if possible.

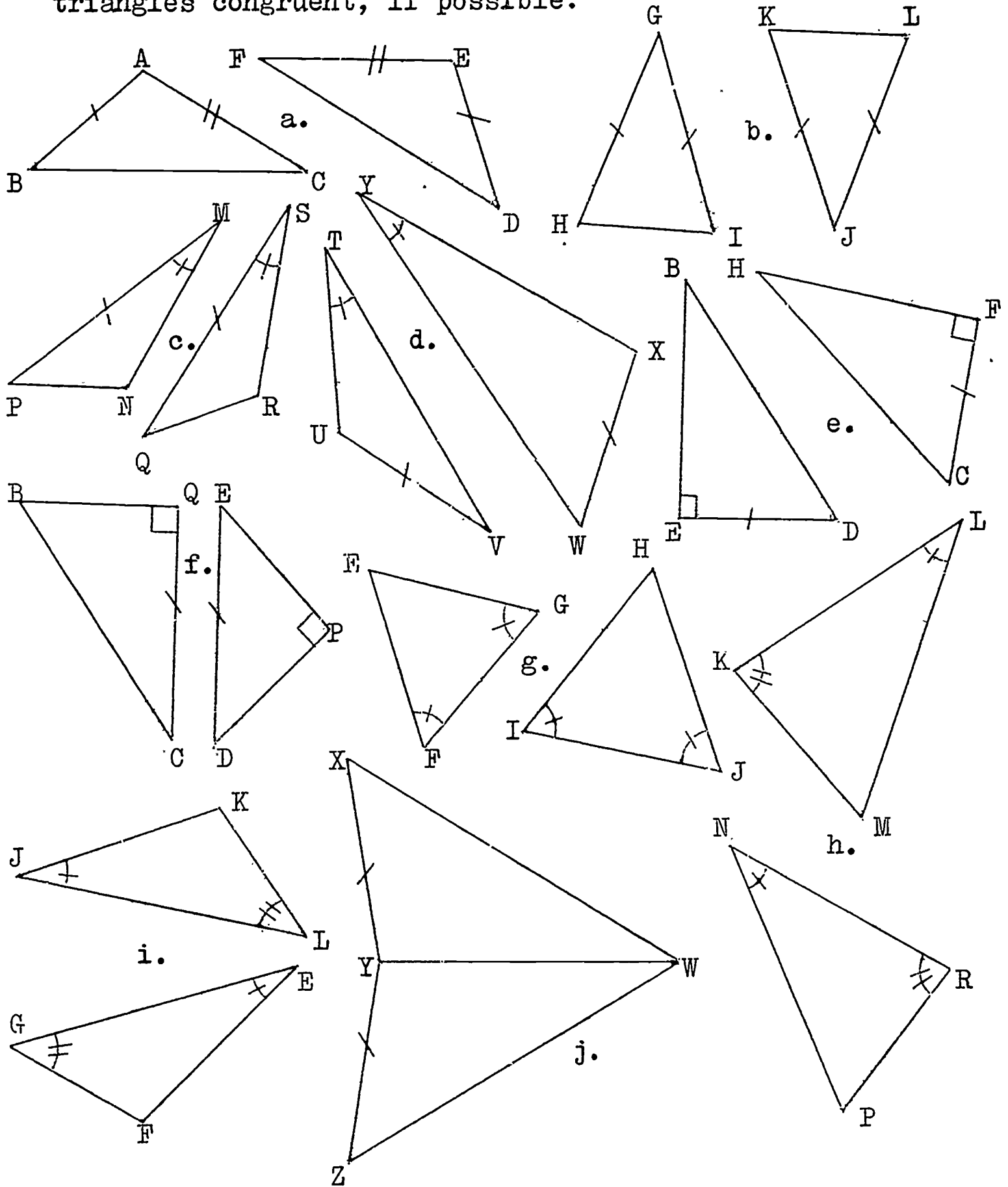

3-8 Congruence of Right Triangles: Hypotenuse and Side (RHS)

You can discover another case of congruence for right triangles in the following:

Class Activity

1. On a piece of heavy paper, draw \overline{AB} 3 inches long.
2. With your protractor and ruler, draw \overline{BD} such that $m\angle ABD = 90^\circ$.
3. Set your compass to a radius of 3.9 inches. With centre at A, draw an arc intersecting \overline{BD} at C. Draw \overline{AC} .
4. Cut out right triangle ABC.
5. Place your right $\triangle ABC$ onto this right $\triangle XYZ$:

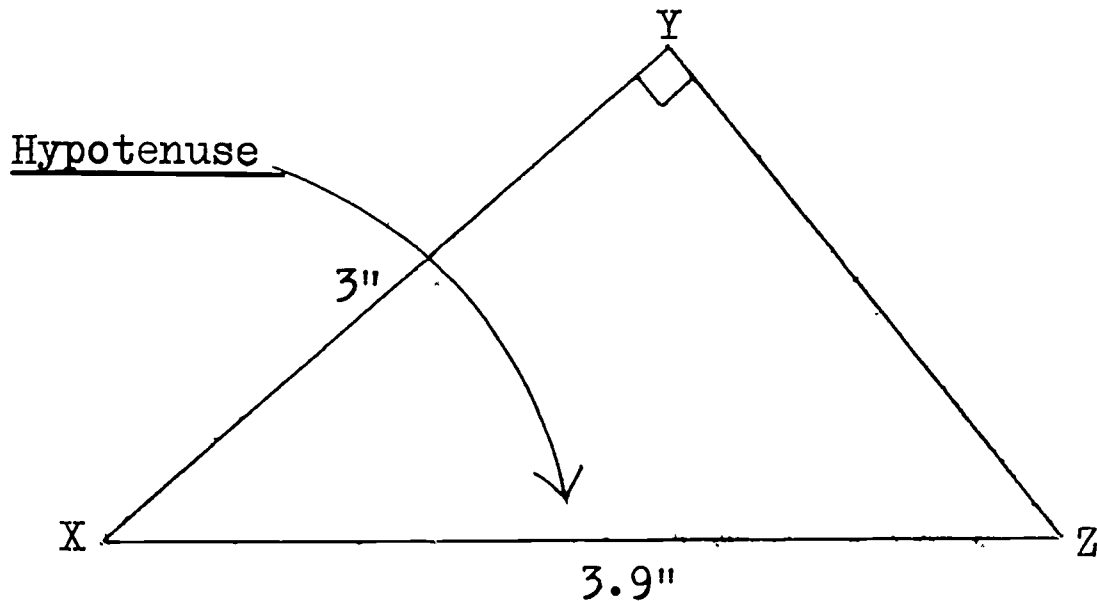

6. Do the two triangles fit exactly? Are they congruent?
7. Place your triangle ABC on top of your neighbour's triangle ABC. Do they fit exactly? Are they congruent?

.....

When you constructed your right triangle ABC, you started with the following information:

$$m \angle ABC = 90 \quad (\text{degrees})$$

$$m \overline{AB} = 3.0 \quad (\text{inches})$$

$$m \overline{AC} = 3.9 \quad (\text{inches})$$

\overline{AC} of right $\triangle ABC$ is called the hypotenuse of the triangle. Notice that the hypotenuse is the side opposite the right angle.

The three parts from which you made $\triangle ABC$ were the right angle, the hypotenuse, and one side.

Repeat Steps 1 - 5 for $\triangle KLM$ in which:

$$m \angle KLM = 90$$

$$m \overline{KL} = 12 \quad (\text{cms.})$$

$$m \overline{KM} = 13 \quad (\text{cms.})$$

What is true of your $\triangle KLM$ and your neighbour's ?

If two right triangles have the hypotenuse and a side of one congruent to the hypotenuse and a corresponding side of the other, then the two triangles are congruent. We call this the Right angle-Hypotenuse-Side case of congruent triangles, and we abbreviate RHS .

If two right triangles have the hypotenuse and one side of one congruent to the hypotenuse and the corresponding side of the other, then the two right triangles are congruent. (RHS)

Exercises 3-8

1. Given: $\overline{AD} \perp \overline{BC}$
 $\overline{AB} \cong \overline{AC}$

- Is $\overline{AD} \cong \overline{AD}$? Why?
- Are $\angle BDA$ and $\angle CDA$ right angles? Why?
- Is $\triangle ABD \cong \triangle ACD$? Why?

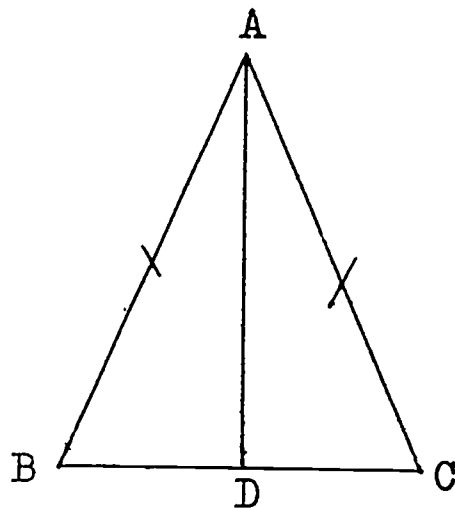

2. Given: Z the midpoint of \overline{XV}
 Z the midpoint of \overline{YW}
 $\overline{YW} \perp \overline{XY}$ and $\overline{YW} \perp \overline{WV}$

- Why is $\triangle XYZ \cong \triangle VWZ$?
- Is there a second reason why $\triangle XYZ \cong \triangle VWZ$?

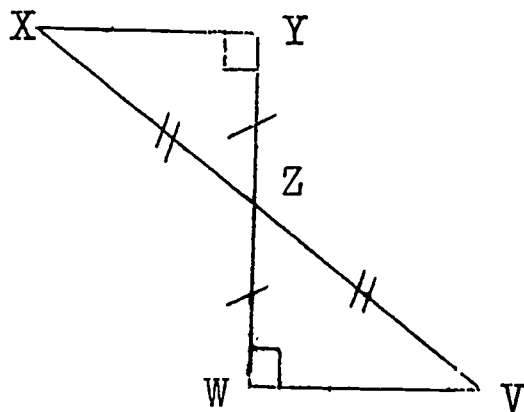

3. Given: $\overline{AC} \cong \overline{BD}$
 $\angle ADC$ and $\angle DCB$
 right angles

- Is $\overline{AC} \cong \overline{BD}$? Why?
- Is $\angle ABC \cong \angle DCB$? Why?
- Is $\overline{BC} \cong \overline{BC}$? Why?
- Is $\triangle ABC \cong \triangle DCB$? Why?

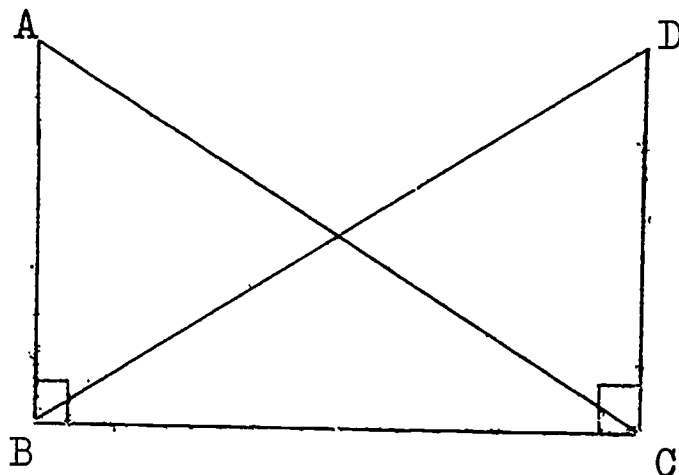

4. Given: ABCD a rhombus
 $\overline{AC} \perp \overline{DB}$

- Why is $\triangle ADE \cong \triangle CED$?
- Is $\triangle ADE \cong \triangle ABE$? Why?
- Is $\triangle ABE \cong \triangle CED$? Why?

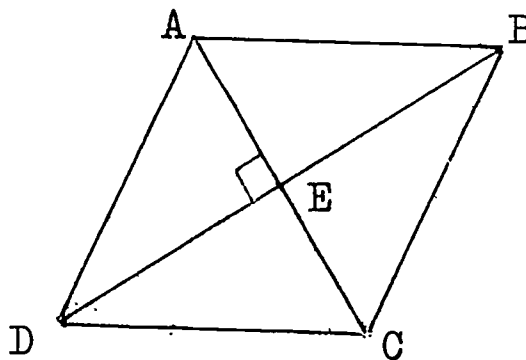

5. Write SSS, ASA, AAS, SAS or RHS to indicate why the following pairs of triangles are congruent. If they are not congruent, write "Not congruent".

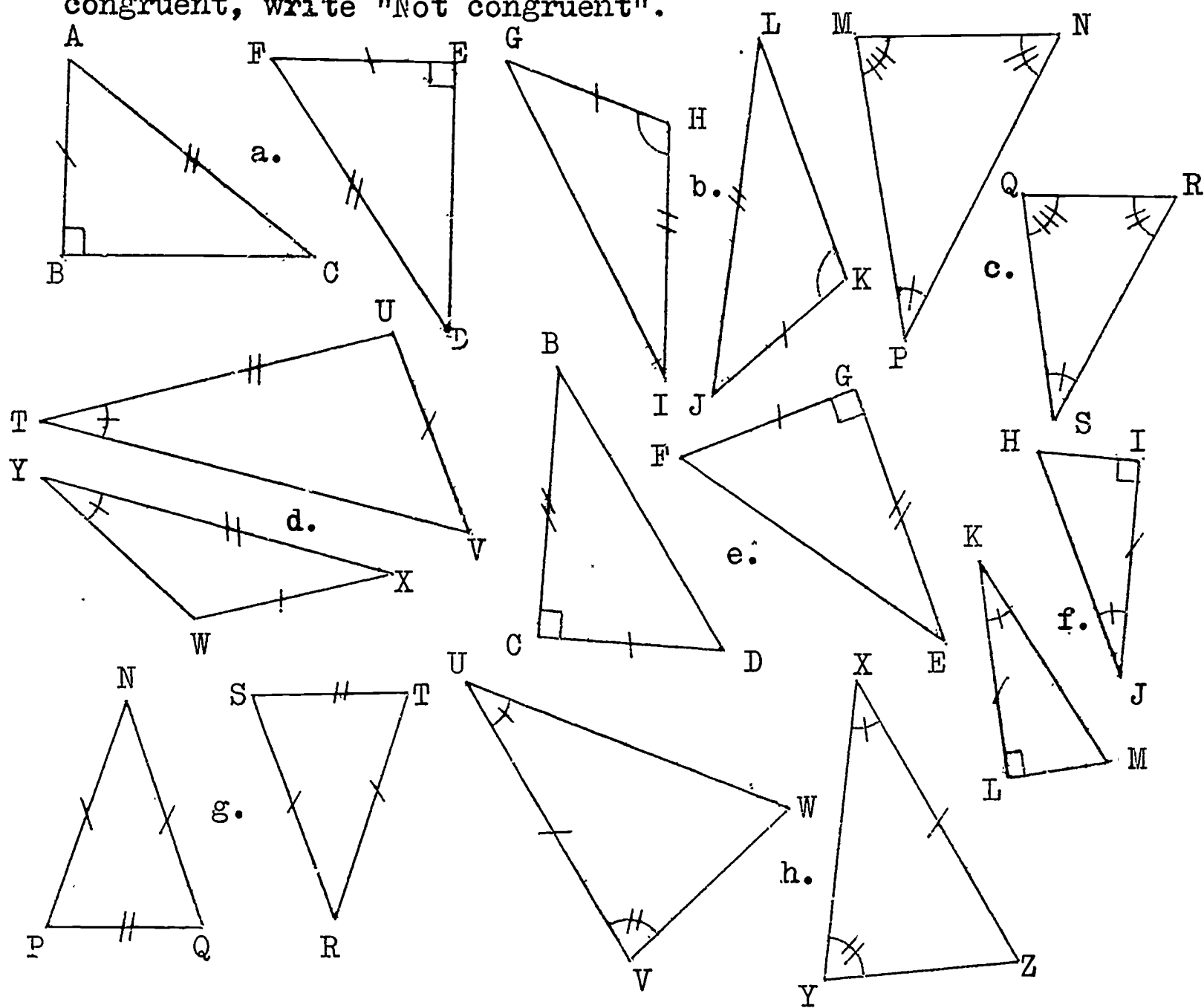

6. For each pair of congruent triangles in Exercise 5 above, write the correct correspondence of vertices. For example, in 5 (a), $\triangle ABC \cong \triangle FED$.

3-9 Summary of Congruent Triangles

You realize that, in order to have two triangles congruent, you must have certain three parts of one congruent to the corresponding three parts of the other. Must one of those three parts be a side of the triangle? Let us summarize these cases of congruency of triangles which you have studied:

1. SAS

Side-Angle-Side

Note that the angle must be the angle included between the corresponding sides.

2. SSS

Side-Side-Side

3. ASA

Angle-Side-Angle

Note that the congruent sides must be corresponding.

4. AAS

Angle-Angle-Side

Note that the congruent sides must be corresponding.

5. RHS

Right angle-Hypotenuse-Side

Exercises 3-9

1. Given: $\overline{XY} \cong \overline{AB}$
 $\angle A \cong \angle X$
 $\overline{AC} \cong \overline{XZ}$

Is $\triangle ABC \cong \triangle XYZ$? Why?

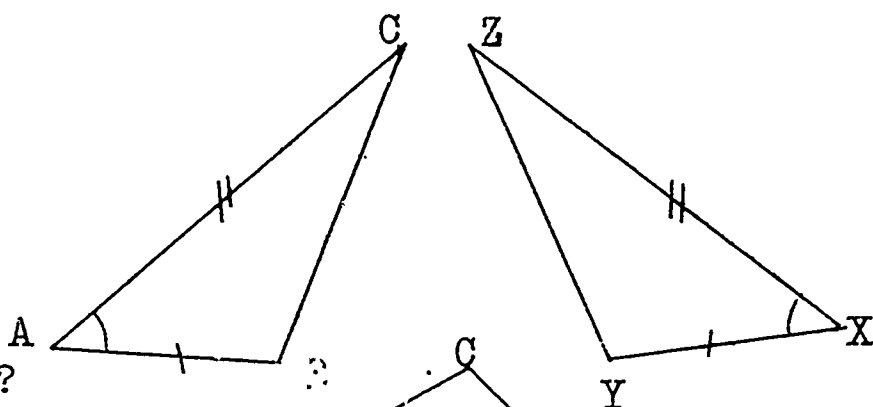

2. Given: $\overline{AC} \cong \overline{AD}$
 $\overline{BC} \cong \overline{BD}$

Is $\triangle ACB \cong \triangle ADB$? Why?

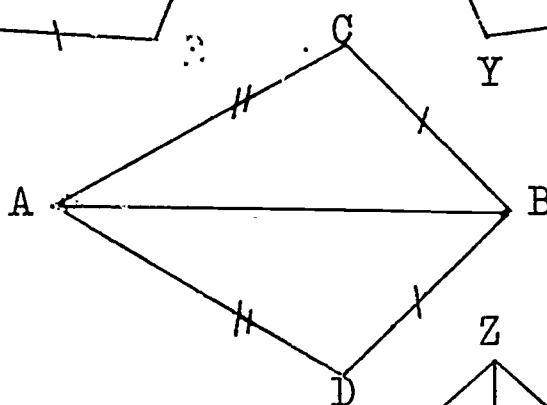

3. Given: $\overline{ZX} \perp \overline{WY}$
 $\angle W \cong \angle Y$

Is $\triangle WXZ \cong \triangle YXZ$? Why?

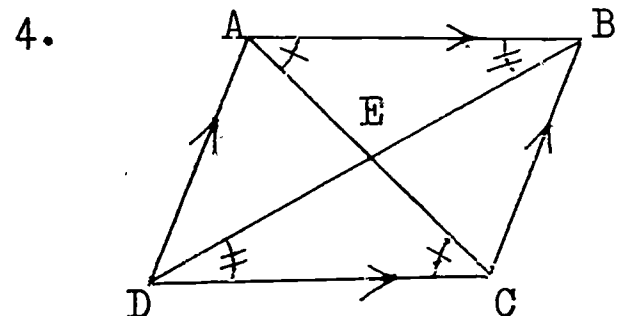
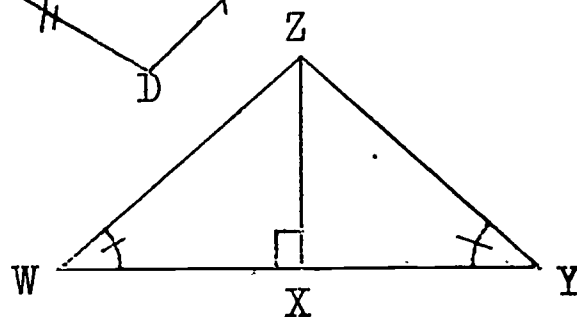

Is $\triangle ABE \cong \triangle CED$? Why?

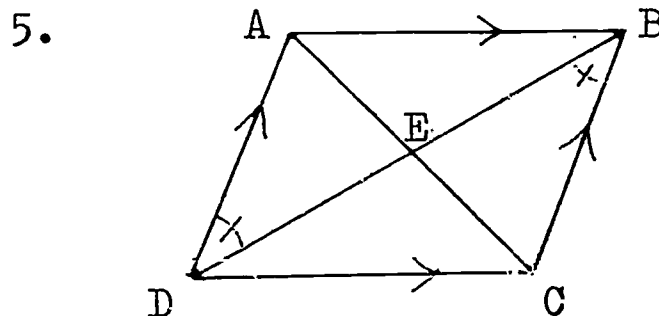

Is $\triangle ADE \cong \triangle CBE$? Why?

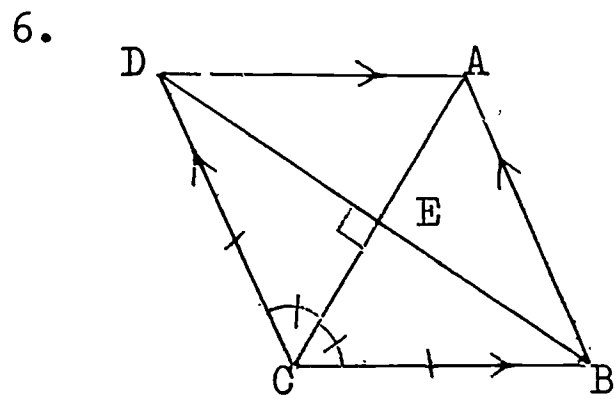

Is $\triangle CDE \cong \triangle CBE$? Why?

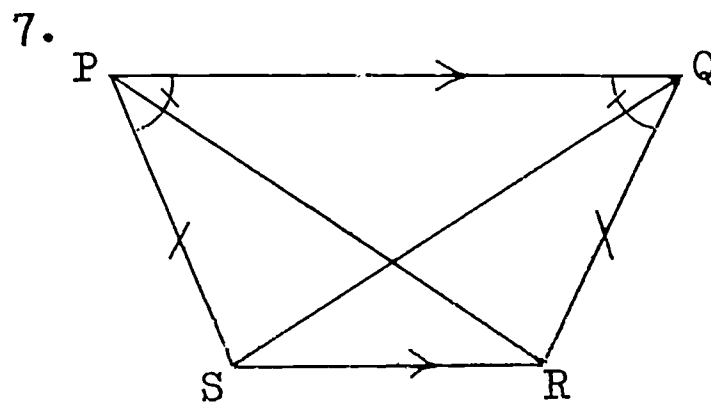

Is $\triangle PQR \cong \triangle QPS$? Why?

8. In the following pairs of triangles, the congruent parts are marked. If the triangles are congruent, write the rule which tells why.

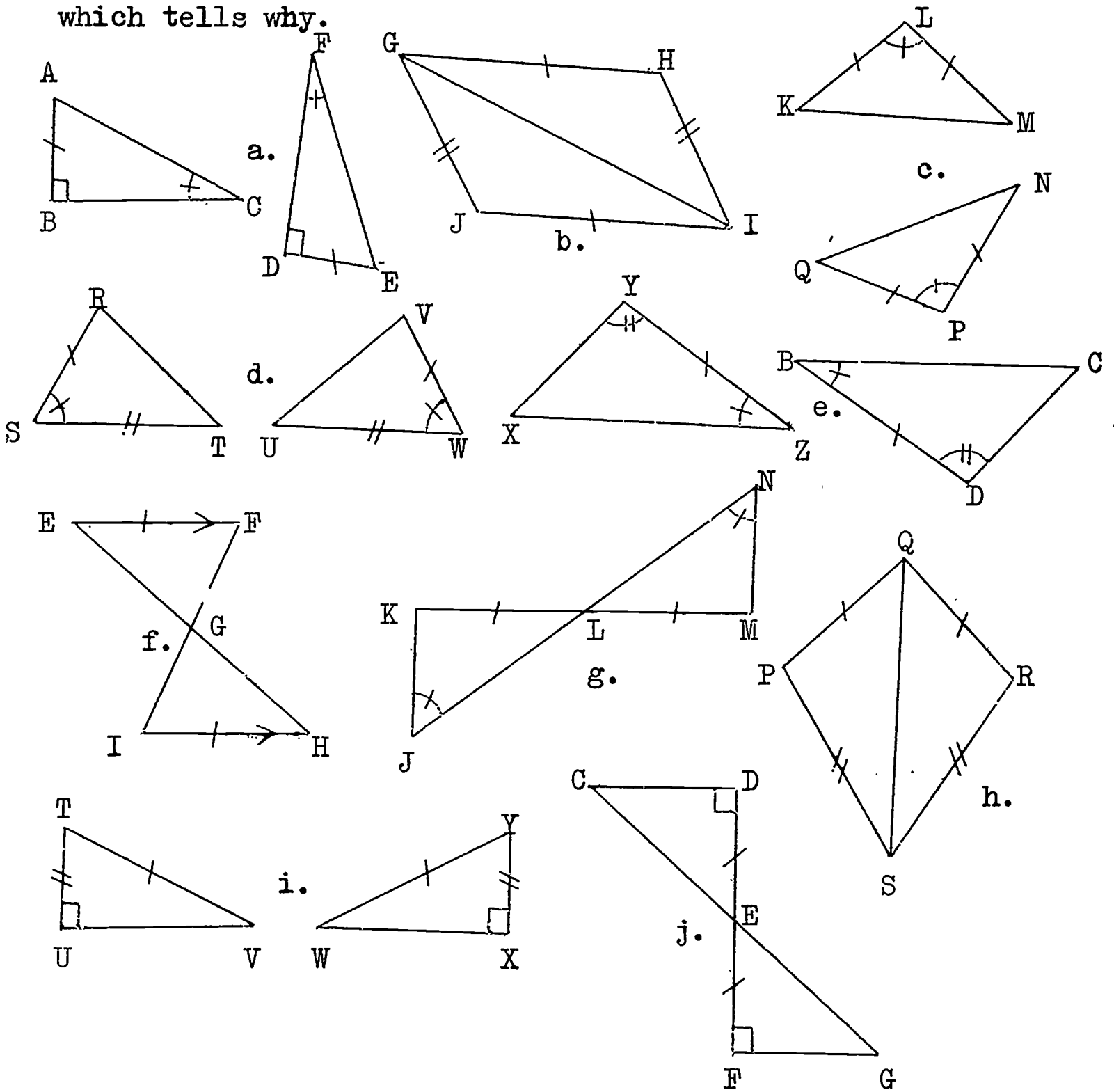

9. For each pair of congruent triangles in Exercise 8 above, write the correct correspondence of vertices. For example, in 8 (a), $\triangle ABC \cong \triangle EDF$

10. In each of the following pairs of triangles, two pairs of congruent parts are given. Write the third pair needed in order to have the triangles congruent, if possible. In some cases, there is more than one correct answer.

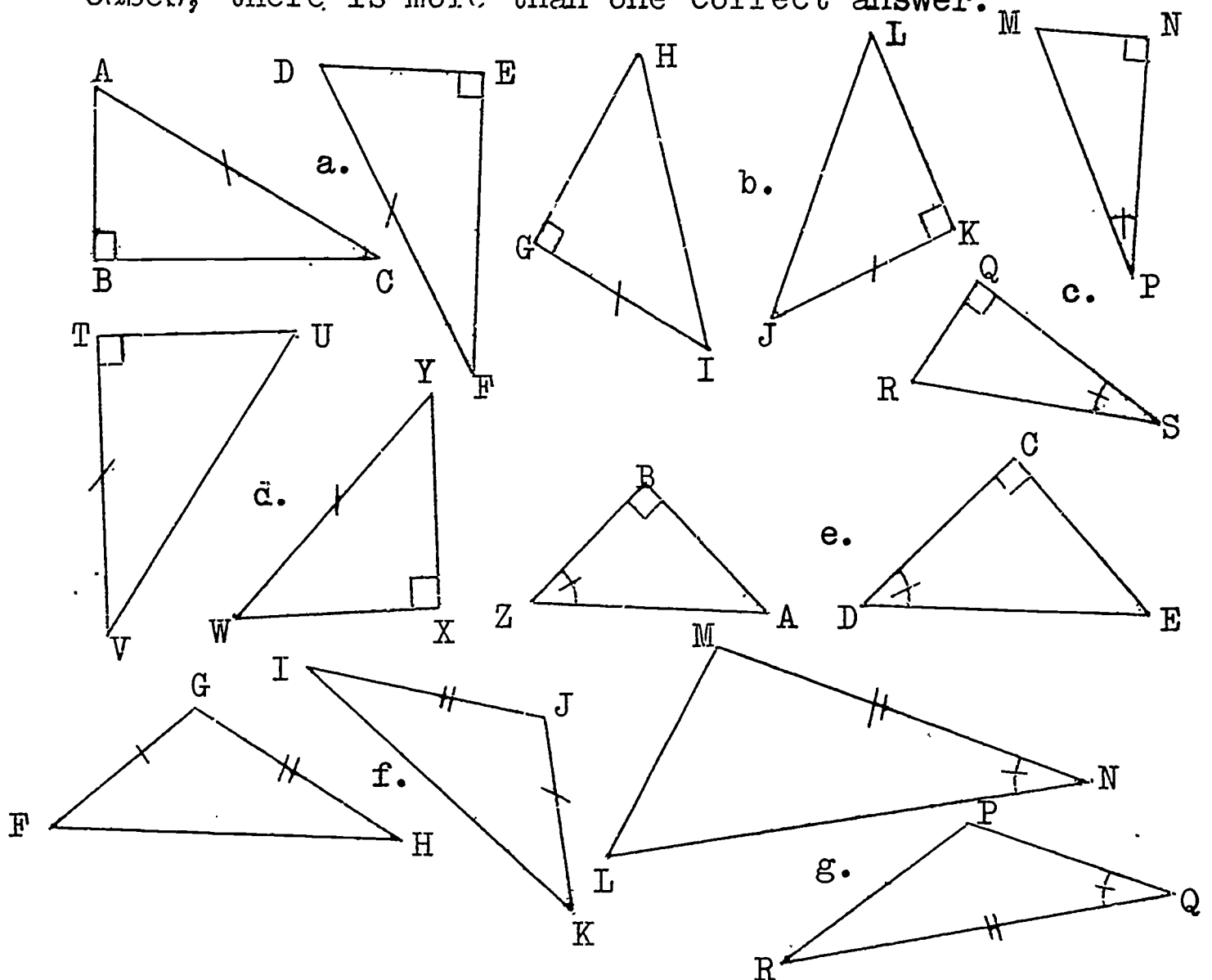

11.

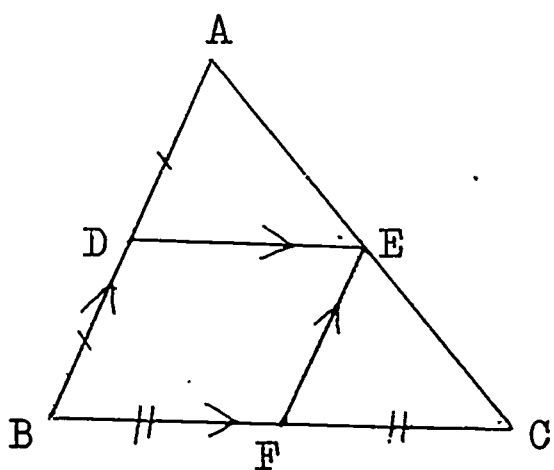

DEFB is a parallelogram.
Is $\triangle ADE \cong \triangle EFC$? Why?

12.

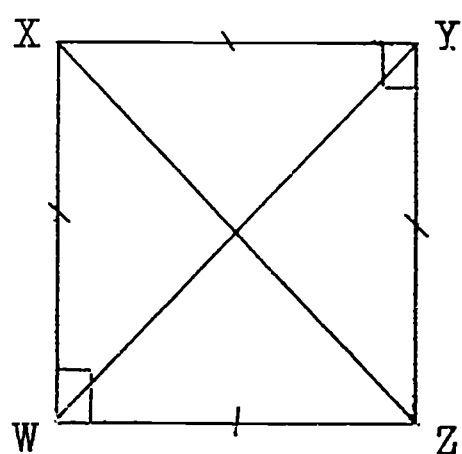

Is $\triangle XYZ \cong \triangle ZWX$? Why?

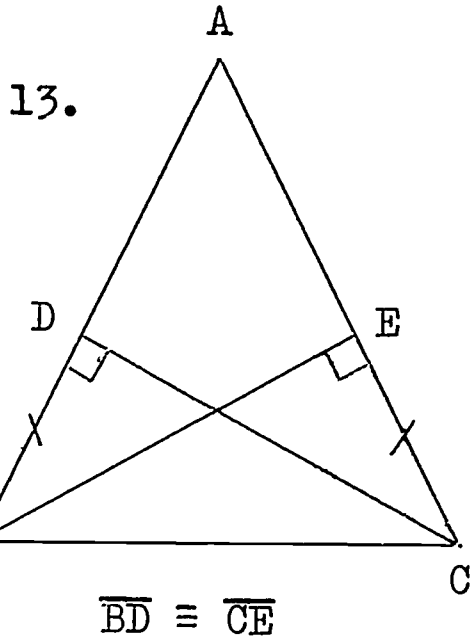

Is $\triangle BDC \cong \triangle CEB$? Why?

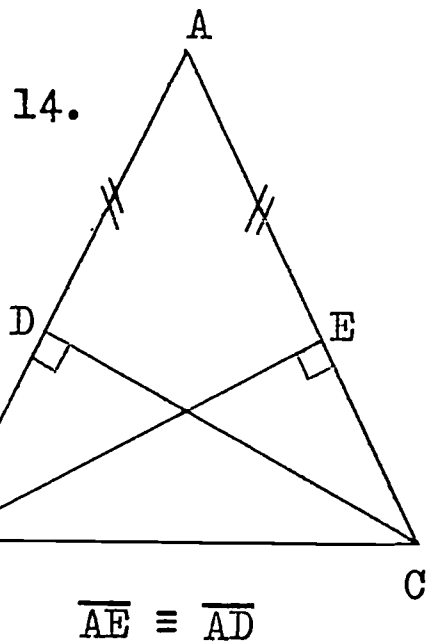

Is $\triangle ADC \cong \triangle AEB$? Why ?

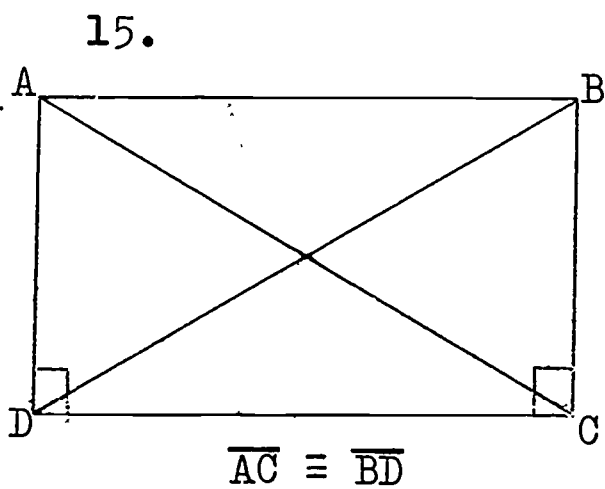

Is $\triangle ADC \cong \triangle BCD$? Why?

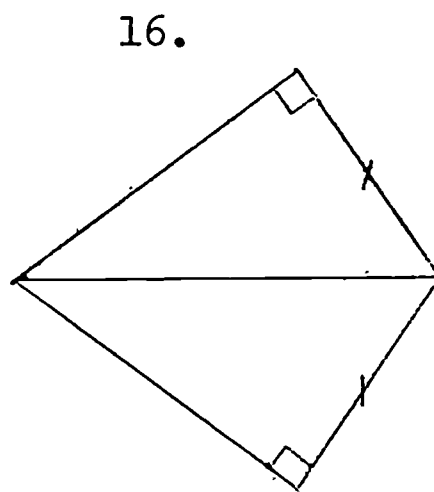

Is $\triangle ABC \cong \triangle ADC$? Why?

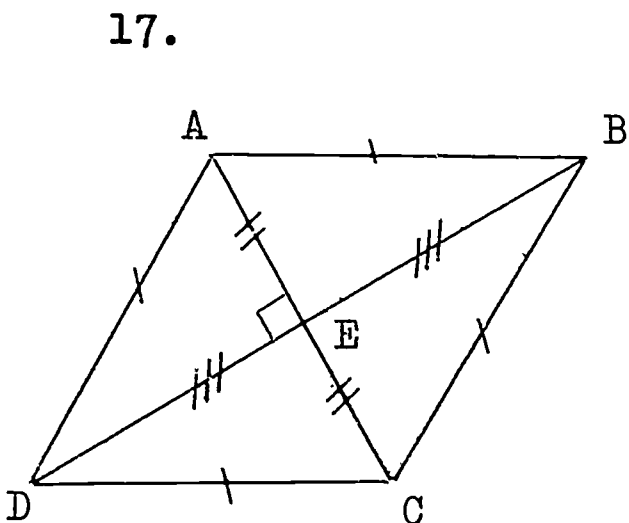

- a. Is $\triangle ADE \cong \triangle CDE$? Why?
- b. Is $\triangle CDE \cong \triangle CBE$? Why?
- c. Is $\triangle ADE \cong \triangle CBE$? Why?

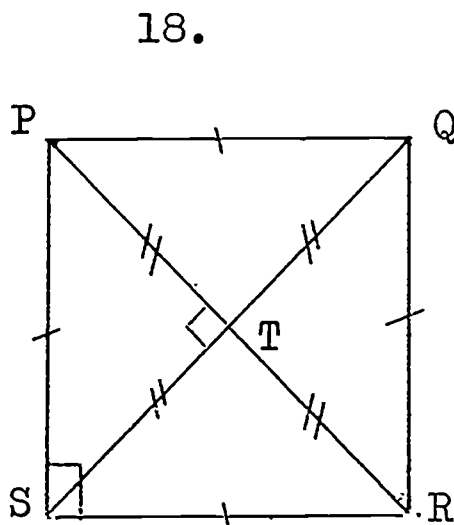

- a. Is $\triangle PST \cong \triangle RST$? Why ?
- b. Is $\triangle RST \cong \triangle RQT$? Why ?
- c. Is $\triangle PST \cong \triangle RQT$? Why ?

3-10 Corresponding Parts of Congruent Triangles

Look at these two triangles:

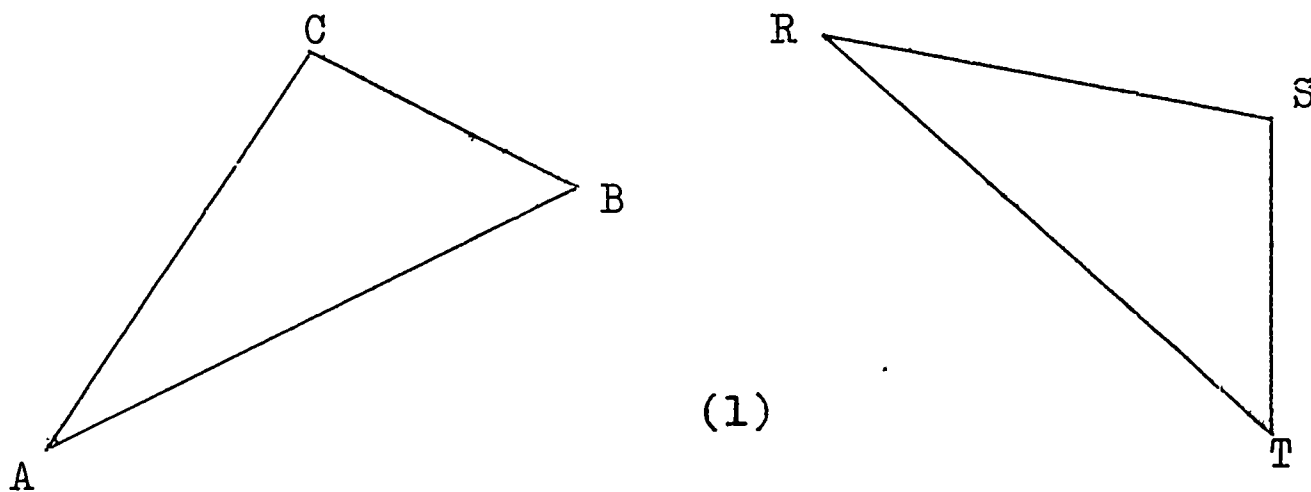

You are given that $\triangle ABC \cong \triangle RTS$. Which side of $\triangle RTS$ corresponds to \overline{BC} of $\triangle ABC$? Does \overline{TS} correspond to \overline{BC} ? Is $\overline{TS} \cong \overline{BC}$?

Angle A corresponds to $\angle R$. Is $\angle A = \angle R$? There are four more pairs of corresponding parts in $\triangle ABC$ and $\triangle RTS$. Can you name them? Are they congruent to each other?

If two triangles are congruent, then all of the corresponding parts are congruent.

Corresponding parts of congruent triangles are congruent.

You recall that when you write the correspondence of the two triangles correctly in

$$\triangle ABC \cong \triangle RTS ,$$

you can immediately decide on the correspondence of the angles and sides by the diagram on the next page:

$$\triangle \textcircled{A} B C \cong \triangle \textcircled{R} T S$$

$$\angle A \cong \angle R$$

$$\triangle \underline{A B C} \cong \triangle \underline{R T S}$$

$$\overline{AB} \cong \overline{RT}$$

$$\triangle A \textcircled{B} C \cong \triangle R \textcircled{T} S$$

$$\angle B \cong \angle T$$

$$\triangle A \underline{B C} \cong \triangle R \underline{T S}$$

$$\overline{BC} \cong \overline{TS}$$

$$\triangle A B \textcircled{C} \cong \triangle R T \textcircled{S}$$

$$\angle C \cong \angle S$$

$$\triangle \underline{A B C} \cong \triangle \underline{R T S}$$

$$\overline{AC} \cong \overline{RS}$$

Exercises 3-10

1. Given $\triangle ABC \cong \triangle RST$
- a. $\angle E$ $\angle A$ because .
- b. $\overline{DE} \cong$ because .
- c. $\cong \overline{AC}$ because .

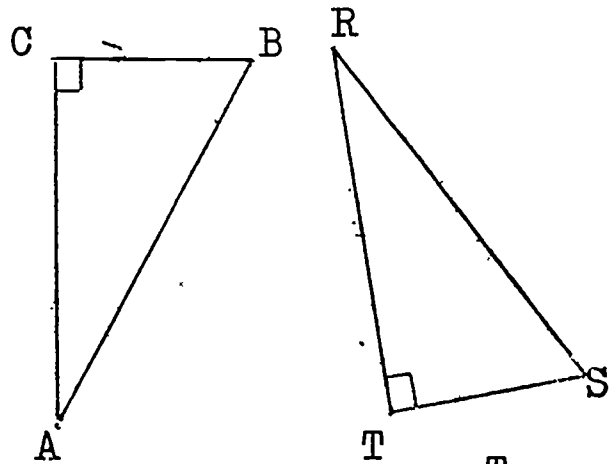

2. Given $\triangle WXY \cong \triangle TZY$
- a. $\angle W \cong$ because .
- b. $\cong \overline{YZ}$ because .
- c. $\overline{WY} \cong$ because .

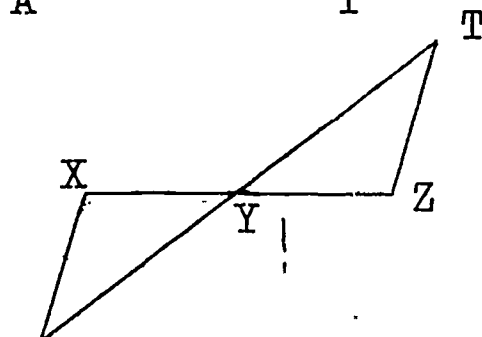

3. Given $\triangle RST \cong \triangle XYZ$, $m \overline{ZY} = 3$
 $m \overline{XY} = 4$, $m \overline{XZ} = 5$
- a. $m \angle T =$ because .
- b. $m \overline{RS} =$ because .
- c. $m \overline{RT} =$ because .
- d. $m \angle R =$ because .

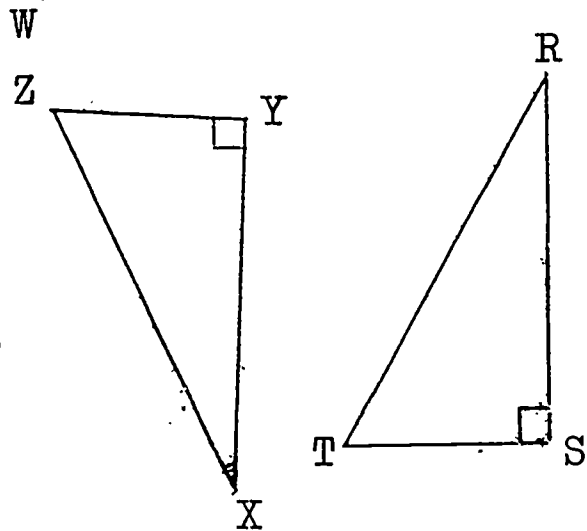

4. Given: $\triangle WYX \cong \triangle WYZ$,
 $m \angle XWZ = 60$, $m \angle XYZ = 80$

- a. $m \angle a = \underline{\hspace{2cm}}$.
 b. $m \angle b = \underline{\hspace{2cm}}$.
 c. $m \angle X = \underline{\hspace{2cm}}$.

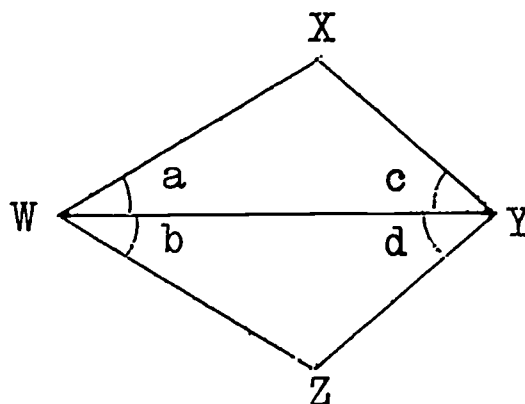

5. Given: $\triangle ABC \cong \triangle DCB$;
 $m \angle BCD = 40$, $m \angle CAB = 70$
 $m \overline{CD} = 4$ (cms.)

- a. $m \angle CBA = \underline{\hspace{2cm}}$ d. $m \angle ACD = \underline{\hspace{2cm}}$
 b. $m \angle CDB = \underline{\hspace{2cm}}$ e. $m \overline{AB} = \underline{\hspace{2cm}}$
 c. $m \angle ACB = \underline{\hspace{2cm}}$

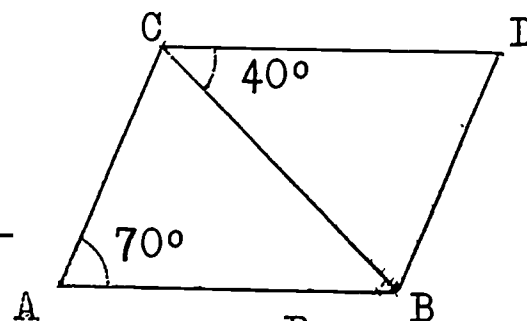

6. Given: Isosceles $\triangle PQR$,
 \overline{PS} bisects $\angle QPR$
- a. Is $\triangle QPS \cong \triangle RPS$? Why ?
 b. Is $\angle Q \cong \angle R$? Why ?
 c. Are the angles opposite the congruent sides of an isosceles triangle congruent ?

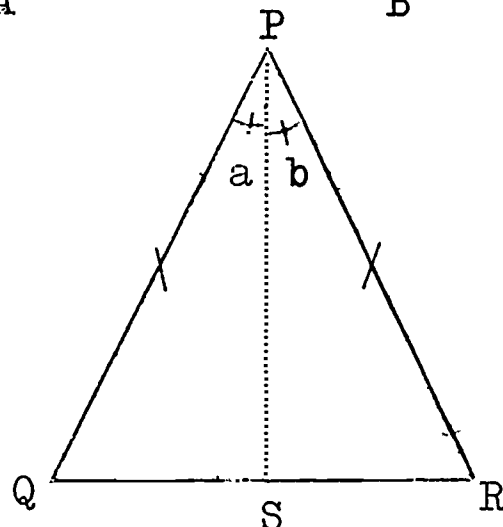

7. Given: $\triangle KLM$ in which $\angle L \cong \angle M$,
 \overline{KN} bisects $\angle LKM$
- a. Is $\triangle KMN \cong \triangle KLN$? Why ?
 b. Is $\overline{KL} \cong \overline{KM}$? Why ?
 c. If two angles of a triangle are congruent, are the sides opposite these angles congruent ?
 d. If two angles of a triangle are congruent, is the triangle isosceles ?

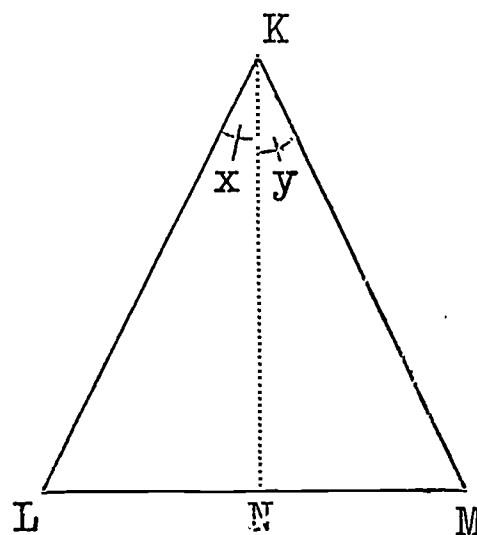

8. Given: $\triangle ABD \cong \triangle CBD$,
 \overline{AC} is a segment

- a. $m \widehat{DC} = \underline{\hspace{2cm}}$ because $\underline{\hspace{2cm}}$.
- b. $m \angle a \underline{\hspace{2cm}} m \angle b$
- c. $\angle a \cong \angle b$ because $\underline{\hspace{2cm}}$.
- d. $m \angle a = \underline{\hspace{2cm}}$.

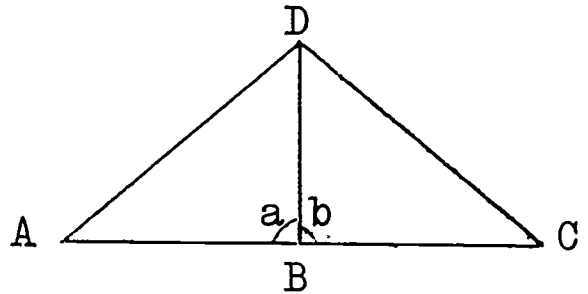

9. Given: $\overline{TR} \cong \overline{FE}$, $\angle E \cong \angle R$
 $\overline{RS} \cong \overline{ED}$

- a. Is $\triangle TRS \cong \triangle FED$? Why?
- b. Is $\angle T \cong \angle F$? Why?
- c. Is $\overline{TS} \cong \overline{FD}$? Why?

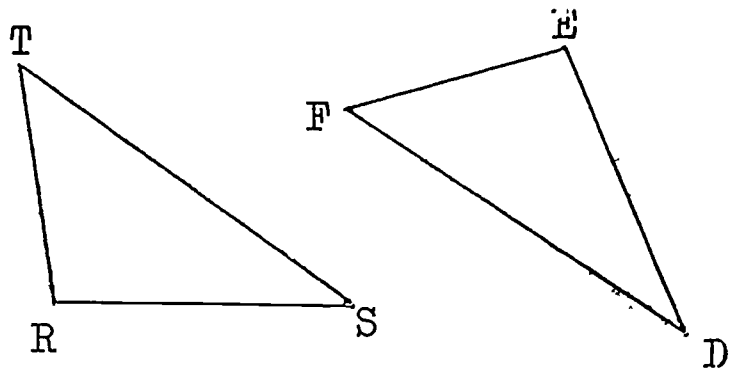

10. Given: C the midpoint of \overline{AE}
 C the midpoint of \overline{BD}

- a. Is $\overline{AC} \cong \overline{EC}$? Why?
- b. Is $\overline{BC} \cong \overline{DC}$? Why?
- c. Is $\angle a \cong \angle b$? Why?
- d. Is $\triangle ABC \cong \triangle EDC$? Why?
- e. Is $\overline{AB} \cong \overline{ED}$? Why?
- f. Is $\angle A \cong \angle E$? Why?

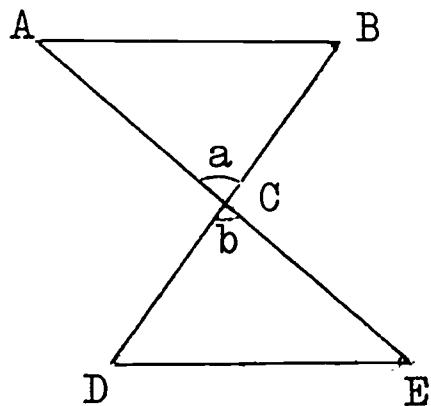

11. Given: \overline{US} bisects $\angle RUT$
 $\overline{US} \perp \overline{RS}$

- a. Is $\triangle USR \cong \triangle UST$? Why?
- b. Is $\overline{RS} \cong \overline{TS}$? Why?
- c. Is $\angle R \cong \angle T$? Why?

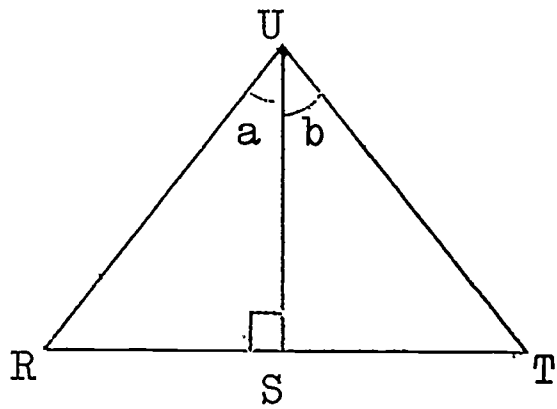

12. Given: X the midpoint of \overline{WY}
 $\overline{WZ} \cong \overline{YZ}$

- a. Why is $\triangle WXZ \cong \triangle YXZ$?
- b. Why is $\angle W \cong \angle Y$?
- c. Is \overline{XZ} the bisector of $\angle WZY$? Why?

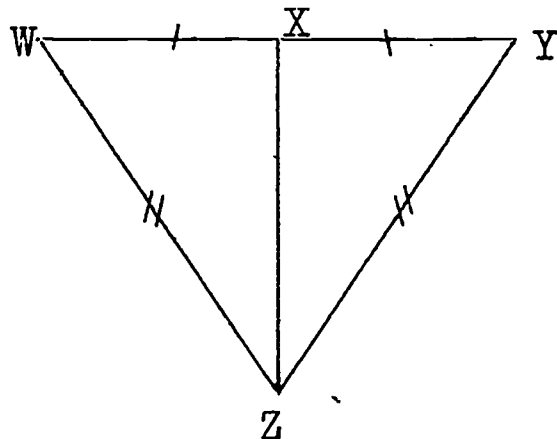

13. Given: $\overline{AC} \cong \overline{CB}$

$$m \angle B = 80$$

a. $m \angle A =$ _____ Why?

b. $m \angle C =$ _____ Why?

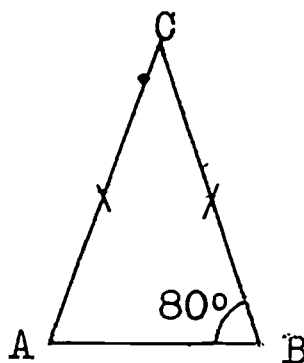

14. Given: $\angle R \cong \angle S$

a. $m \angle R =$ _____

b. $\triangle RST$ is an _____ triangle. Why?

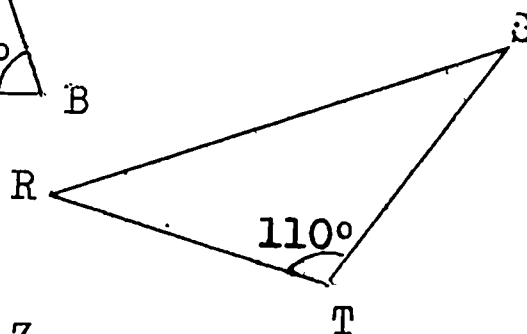

15. Given: $\overline{XY} \perp \overline{XZ}$

$$m \angle Y = 45$$

a. $m \angle Z =$ _____

b. What type of triangle is $\triangle XYZ$? Why?

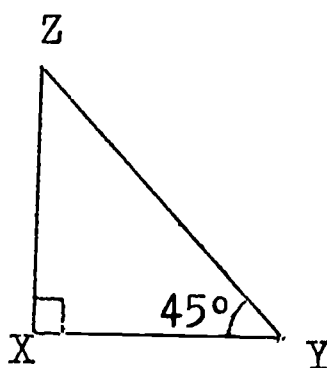

16. Given the figure with data as indicated.

a. $m \angle K = ?$ Why?

b. $\overline{KL} \cong$ _____ Why?

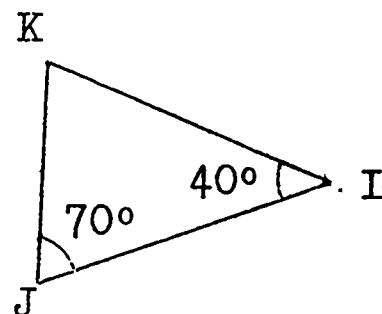

17. Taiwo wishes to find the distance across a swamp. The swamp is too deep to measure by walking across. Taiwo puts stakes in the ground as in the picture. The stakes are placed so that: C is the midpoint of \overline{DB}
C is the midpoint of \overline{AE}
Taiwo measures \overline{DE} and finds that $m \overline{DE} = 45$ (yards). He says, "It is 45 yards across the swamp from A to B".

Is Taiwo correct? Why?

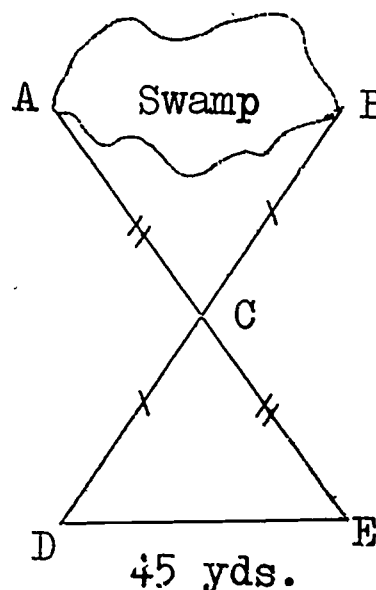

18. Kehinde wants to find the distance across a river. He placed stakes in the ground as in the picture.

C is the midpoint of \overline{BD}
 $\overline{BR} \perp \overline{BD}$, $\overline{DA} \perp \overline{BD}$

How can Kehinde find the distance from point B to the rock across the river ?

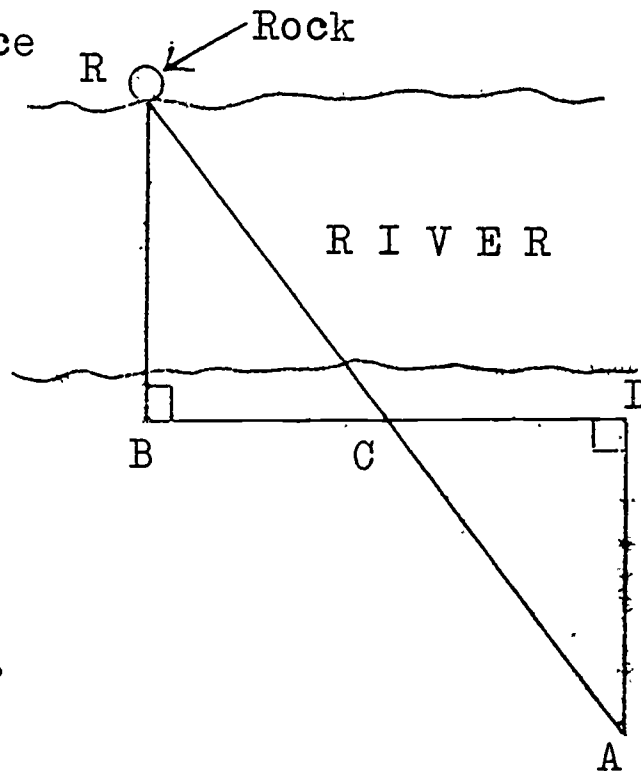

.....

Revision Test # 5

I. Fill in the blank with the correct word, phrase, or number:
 Do your work in your notebook.

1. Two figures are congruent if they _____ .
2. Circle O is congruent to circle P. The diameter of circle O is 8 inches. The radius of circle P is _____.
3. If two polygons have the same _____ and the same _____, then they are congruent polygons.
4. Given $\triangle ABC \cong \triangle RST$ such that $m \angle B = 60$ and $m \angle A = 100$.
 $m \angle T =$ _____ .
5. In Question 4 above, if $m \overline{RS} = 5$, then $m \overline{BA} =$ _____.
6. You studied five cases of triangle congruence. List their abbreviations: _____; _____; _____; _____; _____.

7. In the figure,
 $m \angle T =$ _____.

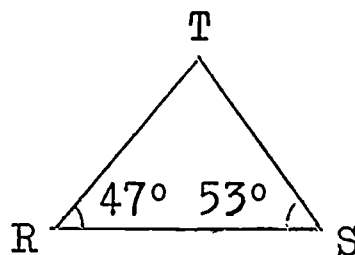

8. In the figure,

$m \angle X = \underline{\hspace{2cm}} .$

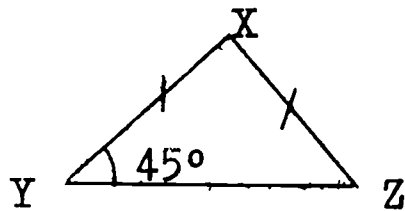

9. Corresponding parts of _____.

10. Write the sentence which is abbreviated by SAS. _____

ii. In the following pairs of triangles, some congruent parts are so marked. If the triangles are congruent, write the abbreviation of the rule which tells why they are congruent. If the marks do not give enough information to decide, write No.

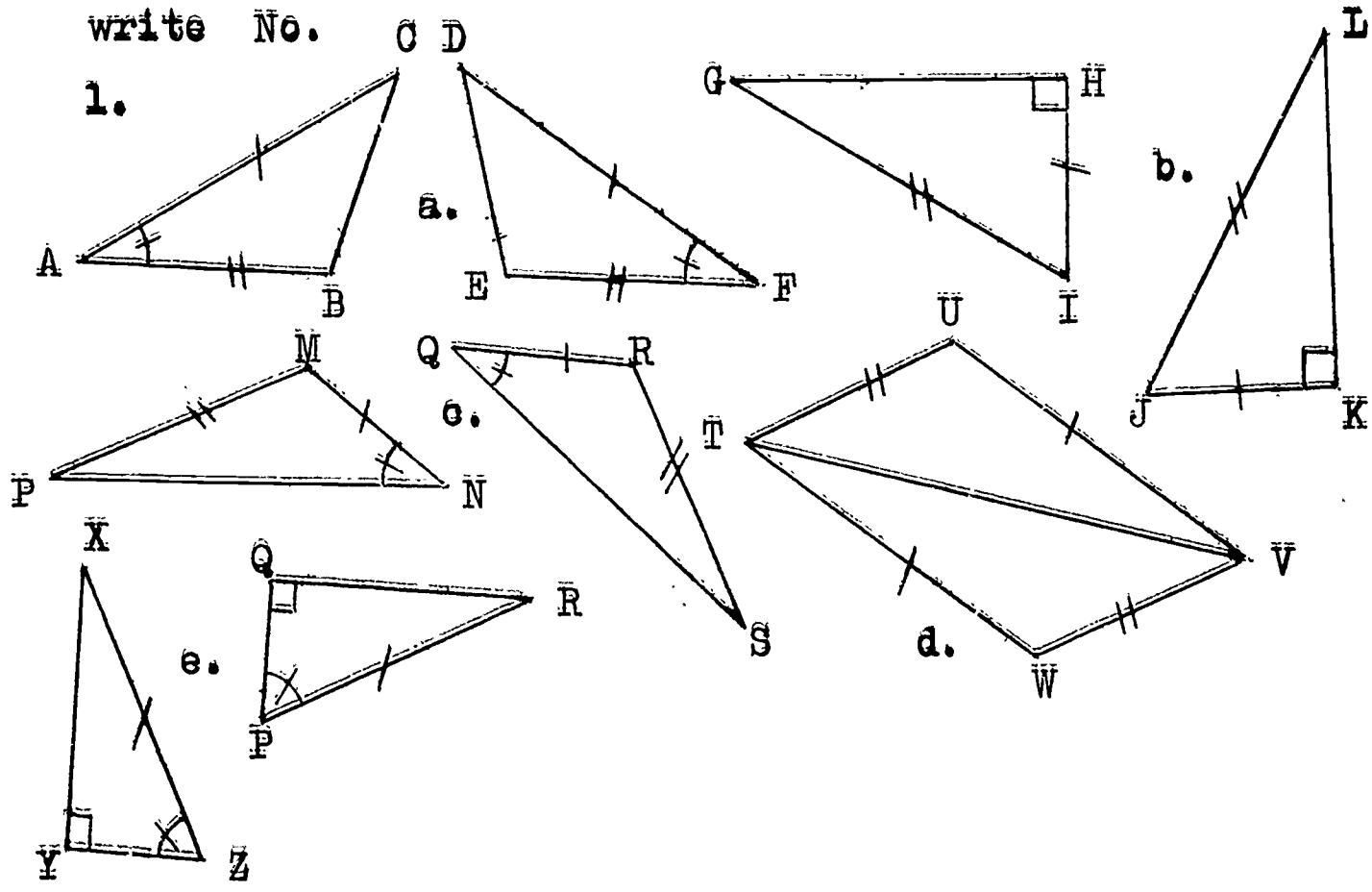

2. For each pair of congruent triangles in Question 1 above, write the correct correspondence of vertices.

III. 1. Given ABCD a parallelogram

- a. Is $\angle a \cong \angle b$? Why ?
- b. Is $\overline{DC} \cong \overline{AB}$? Why ?
- c. Is $\overline{DB} \cong \overline{DB}$? Why ?
- d. Is $\triangle ADB \cong \triangle CBD$? Why ?

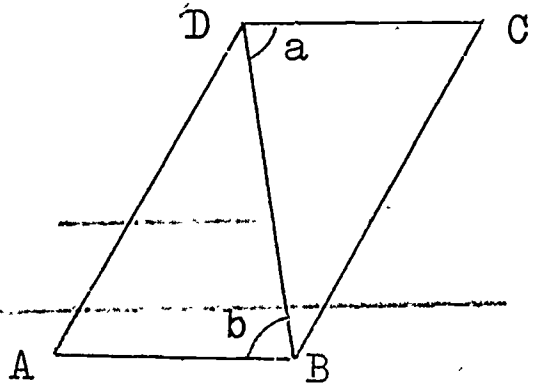

e. What can you say about \overline{AD} and \overline{CB} ? about $\angle A$

2. Given: $\overline{AB} \cong \overline{AC}$, $\overline{BE} \perp \overline{AC}$, $\overline{CD} \perp \overline{AB}$

- a. Is $\overline{BC} \cong \overline{BC}$? Why ?
- b. Is $\triangle BDC \cong \triangle CEB$? Why ?
- c. Is $\overline{CD} \cong \overline{BE}$? Why ?
- d. Is $\triangle ADC \cong \triangle AEB$? Why ?

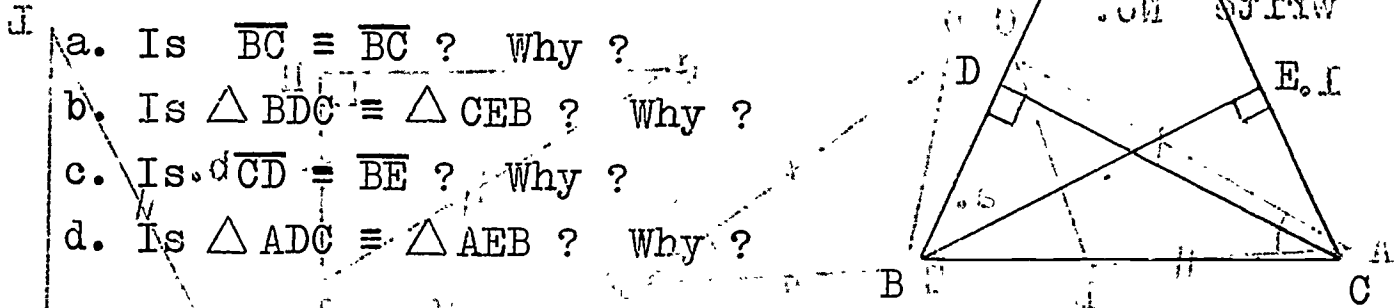

Revision Test # 6

I. Fill in the blank with the correct word, phrase, or number:
Do your work in your notebook.

- 1. If two angles are congruent, they have _____
- 2. If $\overline{RS} \cong \overline{TV}$, and $m \overline{RS} = 4$, then $m \overline{TV} =$ _____
- 3. Parallelogram RSTU \cong Parallelogram WXYZ. If $m \angle R = 50$, then $m \angle X =$ _____
- 4. Congruent triangles have _____ pairs of congruent parts.

5. If all _____ of two triangles are _____, then the two triangles are _____.

6. In the figure,

a. _____ is the angle included between \overline{AC} and \overline{BC}

b. $\angle B$ is included between _____ and _____.

c. \overline{AB} is included between _____ and _____.

d. _____ and _____ are not included between \overline{AC} and \overline{AB} .

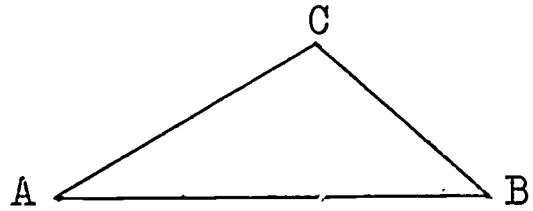

7. In the figure,

a. $m \angle A =$ _____.

b. $\triangle ABC$ is an _____ triangle.

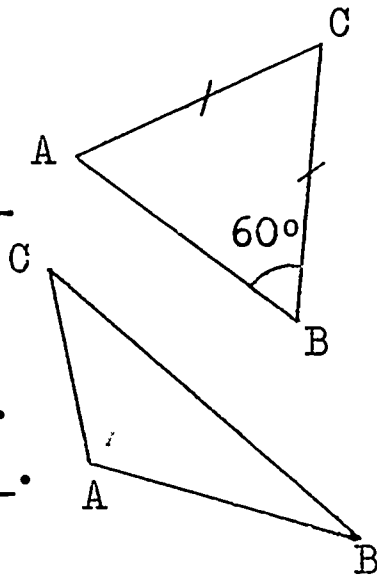

8. Given $\triangle ABC \cong \triangle XYZ$

a. _____ corresponds to \overline{XY} .

b. $\angle B$ corresponds to _____.

c. $\overline{AB} \cong$ _____.

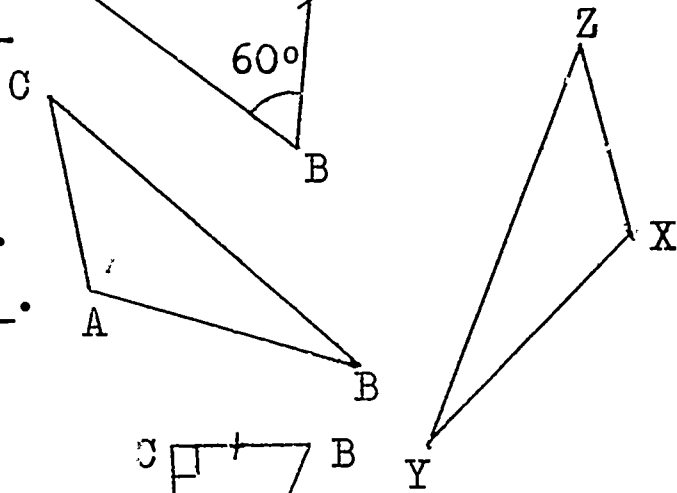

9. $\triangle ABC \cong \triangle DEF$ by _____.

10. $\triangle ABC$ and $\triangle XYZ$ are equilateral triangles, with $\overline{BC} \cong \overline{YZ}$.

a. If $m \overline{AC} = 3$, then $m XY =$ _____.

b. $m \angle A =$ _____ ; $m \angle X =$ _____.

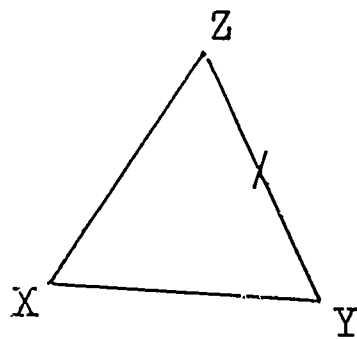
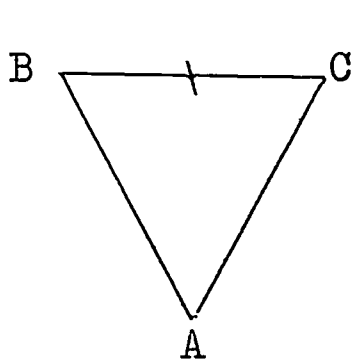
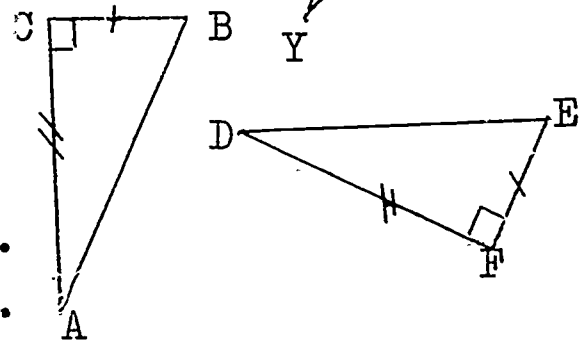

11. 1. In each of the following pairs of triangles, two pairs of congruent parts are given. Write the third pair needed in order to have the triangles congruent, if possible. In some cases, there is more than one correct answer.

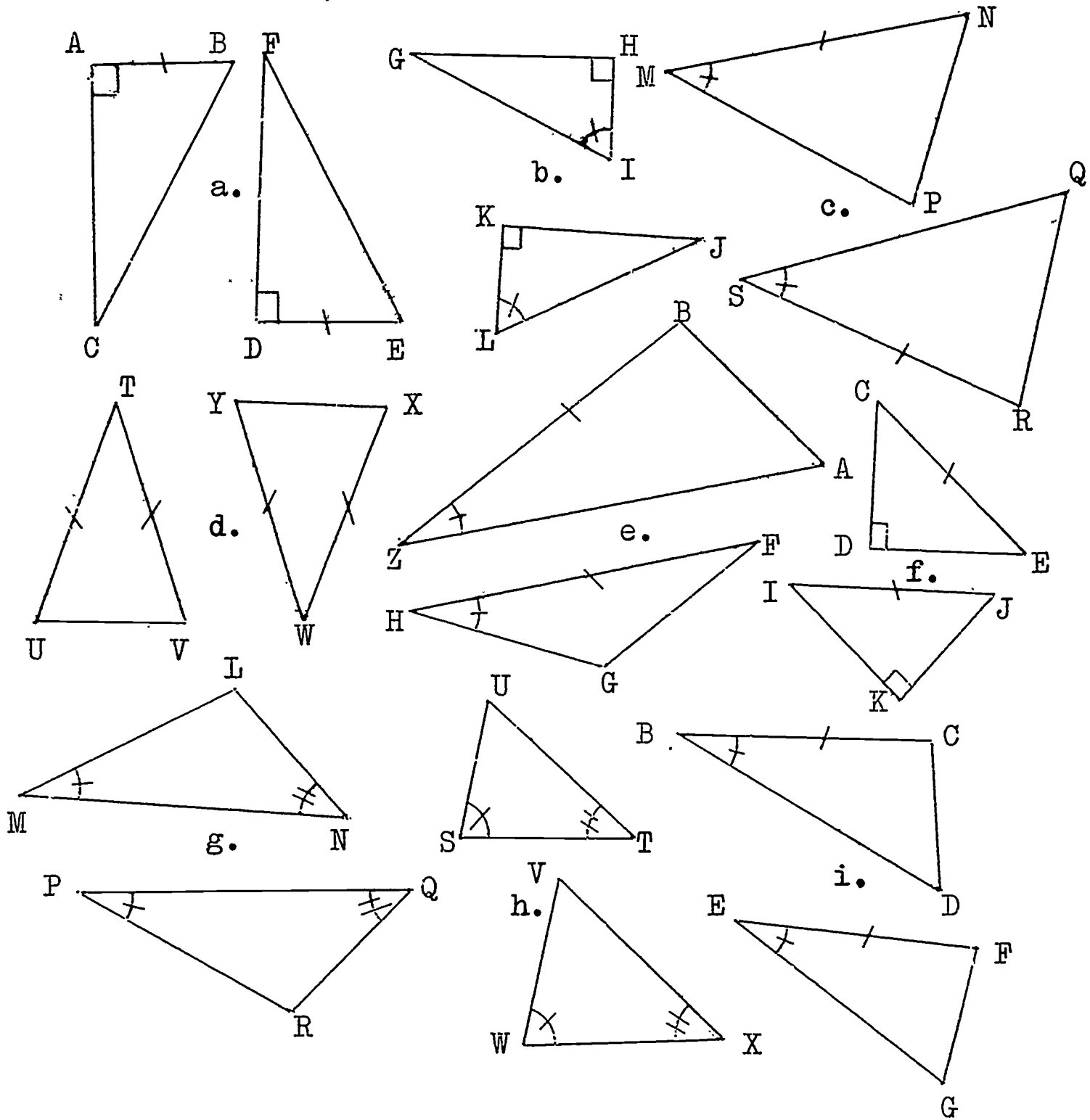

2. For each pair of congruent triangles in Question (1) above, write the correct correspondence of vertices.

III. 1. Given: $\overline{US} \perp \overline{RT}$

$$\angle a \cong \angle b$$

- a. Is $\angle UR S \cong \angle UST$? Why ?
- b. Is $\overline{US} = \overline{US}$? Why ?
- c. Is $\triangle RSU \cong \triangle TSU$? Why ?
- d. Why is $\angle R \cong \angle T$?

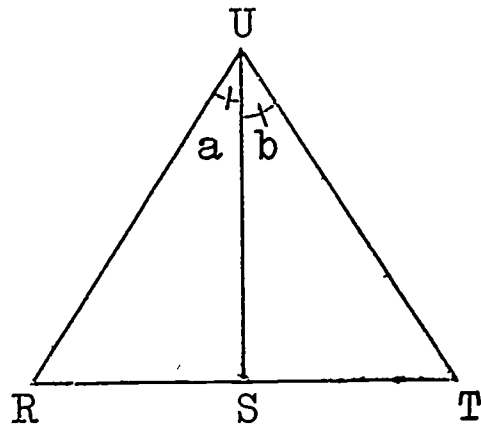

2. Given: ABCD a rhombus

$$\angle a \cong \angle b$$

- a. Is $\overline{DE} \cong \overline{DE}$? Why ?
- b. Is $\triangle AED \cong \triangle CED$? Why ?
- c. Is $\angle c \cong \angle d$? Why ?
- d. $(m \angle c + m \angle d) = \underline{\hspace{2cm}}$.
- e. What can you say about angles c and d ?
- f. What can you say about the diagonals \overline{AC} and \overline{DB} ?

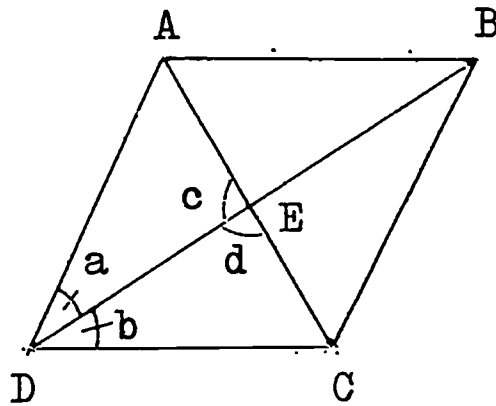

.....

Cumulative Revision Test # 2

I. Fill in the blank to make each sentence true: Do your work in your notebook.

1. If $m \angle A \cong m \angle B$, then $\angle A \underline{\hspace{1cm}} \angle B$.
2. If $\triangle ABC \cong \triangle DEF$, then $\overline{BC} \cong \underline{\hspace{1cm}}$.
3. If $\triangle XYZ \cong \triangle KLM$, then $\angle Z \cong \underline{\hspace{1cm}}$.
4. The side opposite the right angle in a right triangle is called the .

5. In a right triangle, the acute angles are _____ .
6. If two triangles have two sides and the _____ angle of one congruent to the _____ two sides and the _____ angle of the other, then the two triangles are _____ .
7. If two triangles have corresponding angles congruent, but corresponding sides not congruent, then they have the same _____ but not the same _____ .
8. Corresponding _____ of _____ triangles are _____ .
9. In an isosceles triangle, the _____ opposite the congruent sides are _____ .
10. If two angles of a triangle are _____, then the sides opposite those angles are also _____ .
11. The sum of the exterior angles of a 17-gon is _____ .
12. If an exterior angle of a regular polygon has measure of 30, then the regular polygon has _____ sides.
13. If an interior angle of a regular polygon has measure of 160, then the regular polygon has _____ sides.
14. The sum of the measures of the interior angles of a polygon of 12 sides is _____ .
15. In a parallelogram, the opposite sides _____ and _____ .
16. A trapezium has _____ pair of opposite sides _____ .
17. A square is a _____ with adjacent sides _____ .
18. A diagonal of a parallelogram separates it into two _____ which are _____ .

II. 1. Match the two triangles which are congruent, where possible:

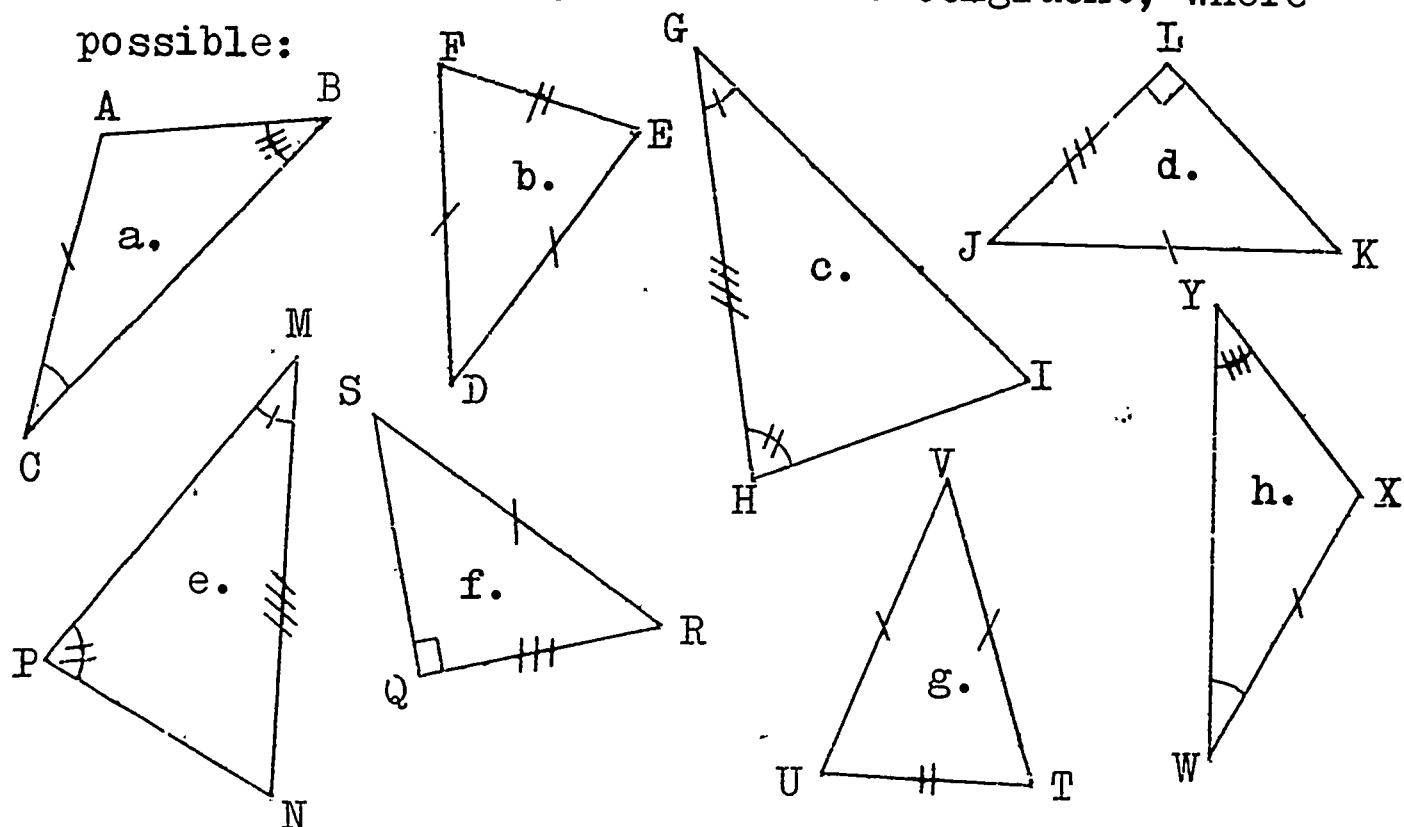

2. For each pair of congruent triangles in Question (1) above, write the correct correspondence of vertices.

III. In each of the following, answer Always if the sentence is always true, Sometimes if the sentence is sometimes true, and Never if the sentence is never true.

1. If two triangles have three corresponding angles congruent, then they are congruent. _____
2. A diagonal of a parallelogram divides it into two congruent triangles. _____
3. If two angles of a triangle are congruent, then the triangle is isosceles. _____
4. If one angle of a triangle is acute, then the other two angles are acute. _____
5. If one angle of a triangle is right, then the other two angles are acute. _____

6. If one angle of a triangle is obtuse, then the other two angles are acute. _____
7. In a regular hexagon, the diagonals divide the hexagon into six congruent triangles. _____
8. If two triangles are congruent, then their corresponding parts are congruent. _____
9. In a right triangle, the hypotenuse is the longest side. _____
10. An altitude of an equilateral triangle divides the triangle into two congruent triangles. _____

IV. 1. Given circle O in which $\angle AOB \cong \angle COD$.

- a. Is $\triangle AOB \cong \triangle COD$? Why?
- b. Is $\overline{AB} \cong \overline{CD}$? Why?

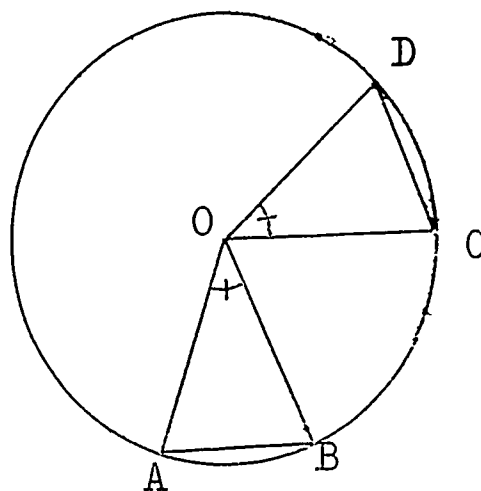

2. Given: ABCD a square
E the midpoint of \overline{AB}

- a. Is $\triangle DAE \cong \triangle CBE$? Why?
- b. Is $\overline{ED} \cong \overline{EC}$? Why?
- c. Is $\angle a \cong \angle b$? Why?
- d. Is $\angle c \cong \angle d$? Why?

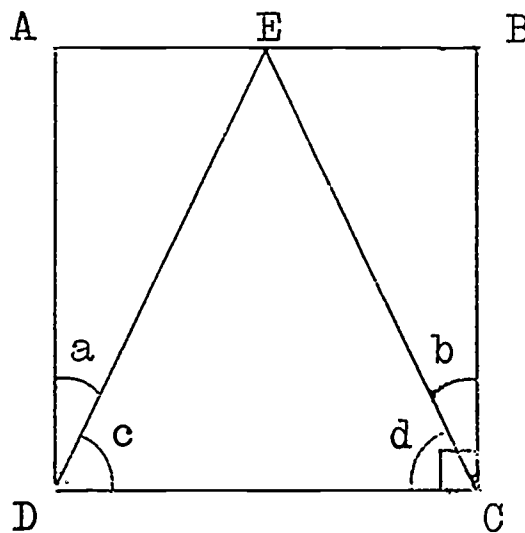

.....

Chapter 4

Basic Constructions

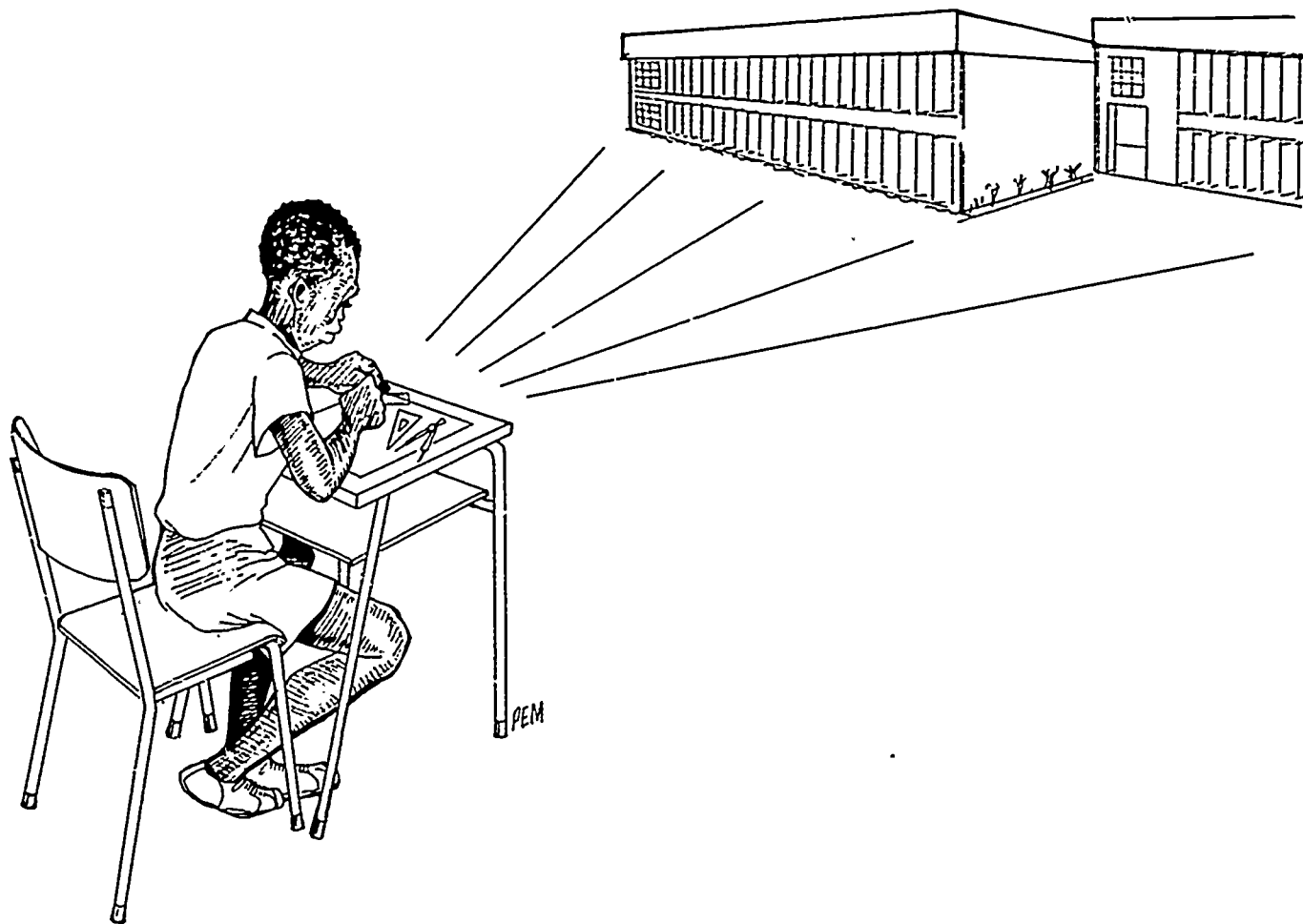

4-1 Introduction

Thus far you have used your ruler and protractor to measure line segments and angles. You also used your compass to draw circles. In this Chapter, you will learn how to construct some basic figures using only your straightedge and compass. You will also learn how to use your set squares. Learning how to use these instruments properly will help you to draw geometrical figures more accurately.

4-2 Set Squares

Here is a picture of your two set squares.

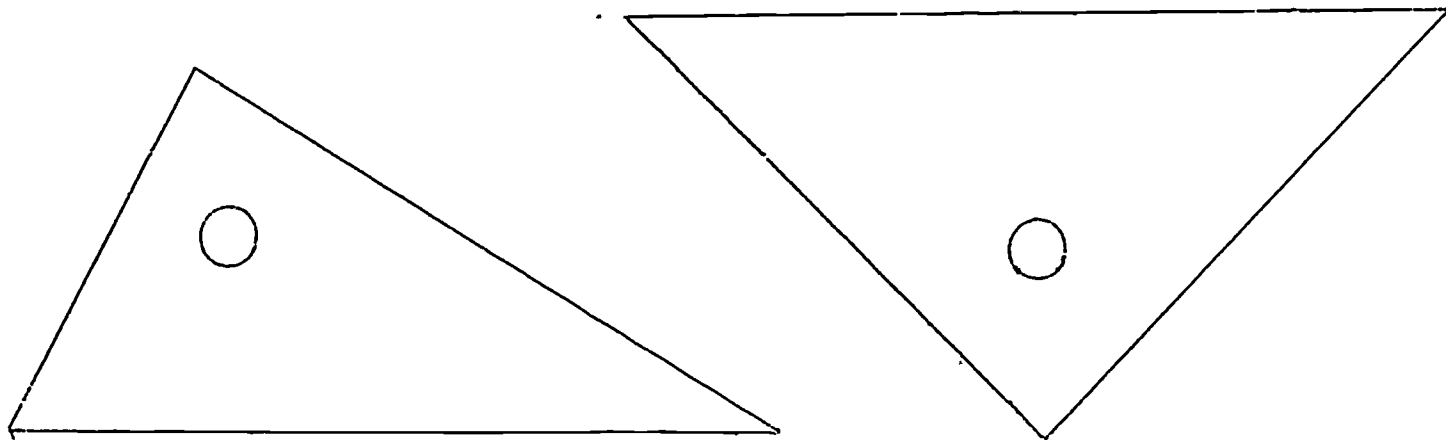

Each of your two set squares is a right triangle. What special name have we given one of these triangles? What is the measure of each angle of the two set squares?

Class Activity

A. To Draw a Line Perpendicular to a Given Line Through a Given Point Not on the Line

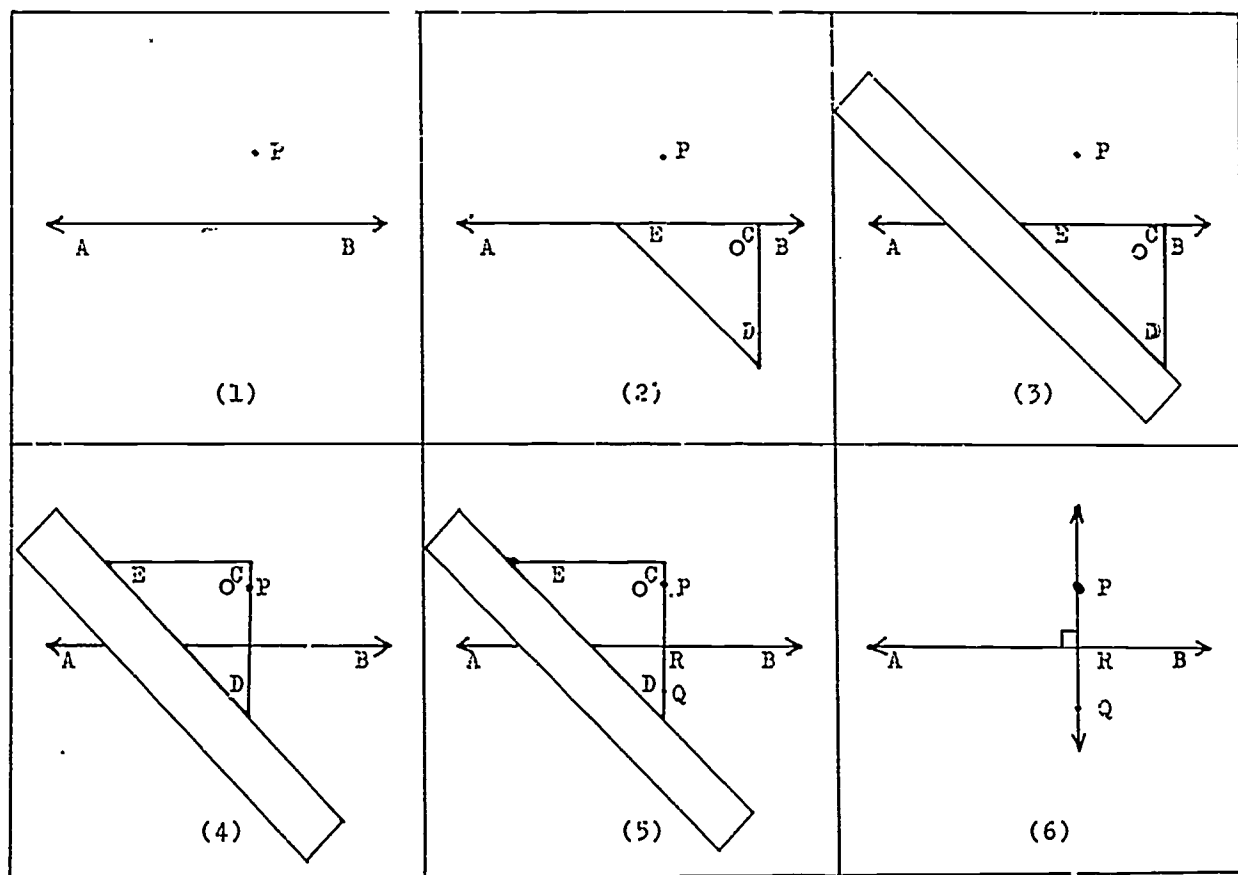

(I)

1. Draw \overleftrightarrow{AB} , and let P be a point not on \overleftrightarrow{AB} .
2. Place one of your set squares so that one of the shorter sides lies on \overleftrightarrow{AB} .
3. Place your ruler along the longest side of your set square.
4. Holding the ruler firmly, slide the set square along the ruler so that point P lies on \overline{CD} .
5. Draw \overline{PQ} to intersect \overleftrightarrow{AB} at R .
6. Remove the set square and draw \overleftrightarrow{PQ} . \overleftrightarrow{PQ} is the line passing through P which is perpendicular to \overleftrightarrow{AB} .

.....

In figure (I,6), what is true of $\angle PRB$ and $\angle PRA$? What can you say about \overleftrightarrow{PQ} and \overleftrightarrow{AB} ? Suppose \overleftrightarrow{AB} contained P . Could you still draw a line \overleftrightarrow{PQ} through P perpendicular to \overleftrightarrow{AB} ?

B. To Draw a Line Parallel to a Given Line Through a Given Point Not on the Line

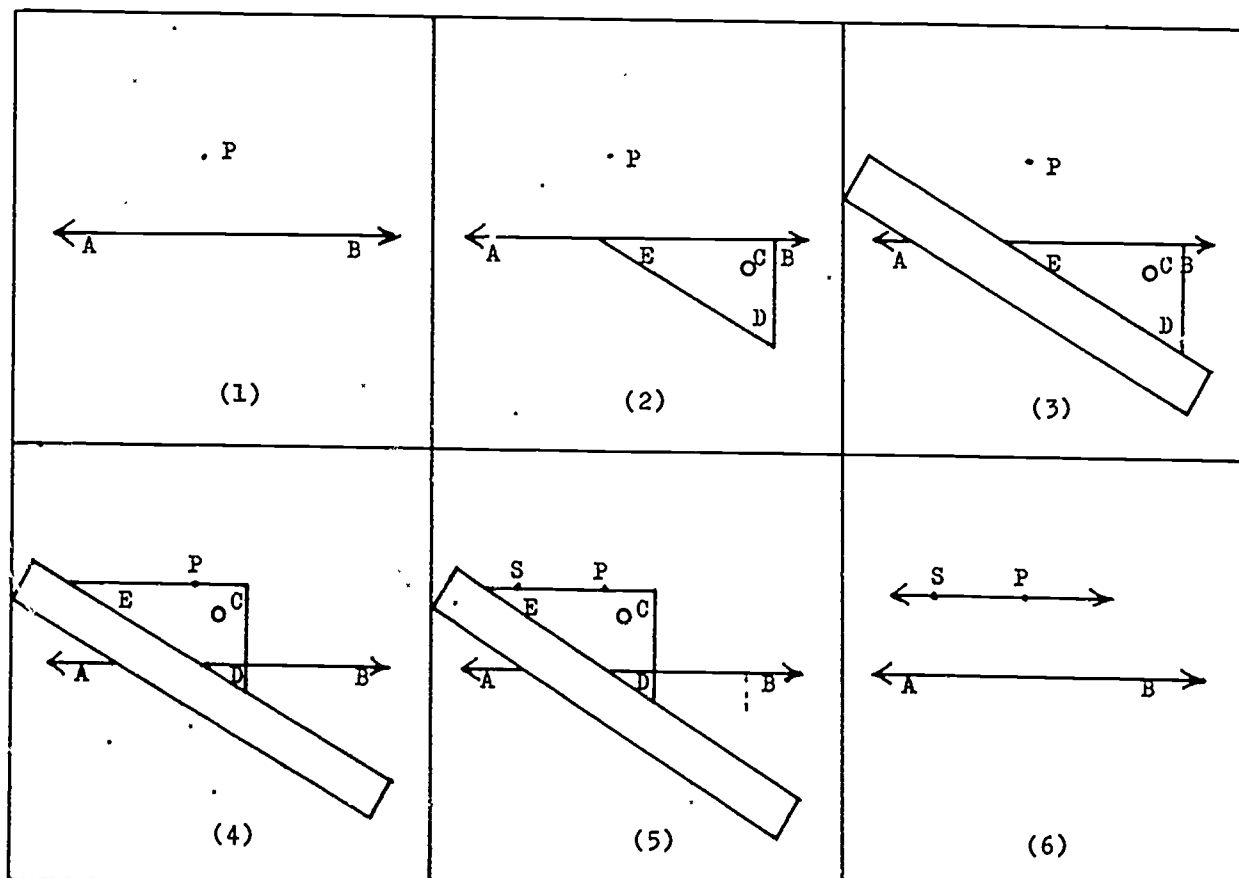

(II)

1. Draw \overleftrightarrow{AB} , and let P be a point not on \overleftrightarrow{AB} .
2. Place one of your set squares so that one of the shorter sides lies on \overleftrightarrow{AB} .
3. Place your ruler along the longest side of your set square.
4. Holding the ruler firmly, slide the set square along the ruler so that P lies on \overline{EC} .
5. Draw \overline{PS} .
6. Remove the set square and draw \overleftrightarrow{PS} . \overleftrightarrow{PS} is the line passing through P which is parallel to \overleftrightarrow{AB} .

.....

In figure (II,6), what is true about \overleftrightarrow{PS} and \overleftrightarrow{AB} ? Suppose the point P were on \overleftrightarrow{AB} . Could you still draw another line through P parallel to \overleftrightarrow{AB} ? Why?

Exercises 4-2

1. a. Draw a line AB . Let C be a point not on \overleftrightarrow{AB} .
 b. Use a set square and ruler to draw a line CD through C which is parallel to \overleftrightarrow{AB} .
 c. Use a set square and ruler to draw \overleftrightarrow{CE} perpendicular to \overleftrightarrow{AB} .
 d. What can you say about \overleftrightarrow{CE} and \overleftrightarrow{CD} ?
2. a. Draw \overline{AB} 2 inches long.
 b. Using your ruler and set square, draw $\overline{DA} \perp \overline{AB}$ at A . Make $m \overline{DA} = 2$ (inches).
 c. Draw $\overline{CB} \perp \overline{AB}$ at B . Make $m \overline{BC} = 2$ (inches).
 d. Draw \overline{DC} .
 e. What kind of figure is $ABCD$? Why?

3. Given the following $\triangle ABC$:

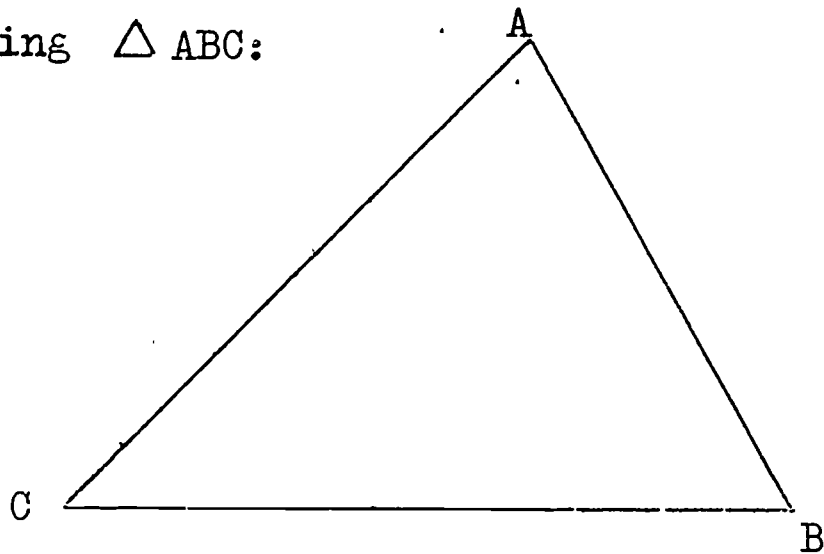

- Copy $\triangle ABC$ into your notebook.
- Using your ruler and set square, draw $\overline{AD} \perp \overline{BC}$, where D is on \overline{BC} . What is \overline{AD} called?
- Draw $\overline{BE} \perp \overline{AC}$, where E is on \overline{AC} . What is \overline{BE} called?
- Draw $\overline{CF} \perp \overline{AB}$, where F is on \overline{AB} . What is \overline{CF} called?
- What do you notice about the intersection of \overline{AD} , \overline{BE} and \overline{CF} ?

4. Given the following obtuse $\triangle ABC$:

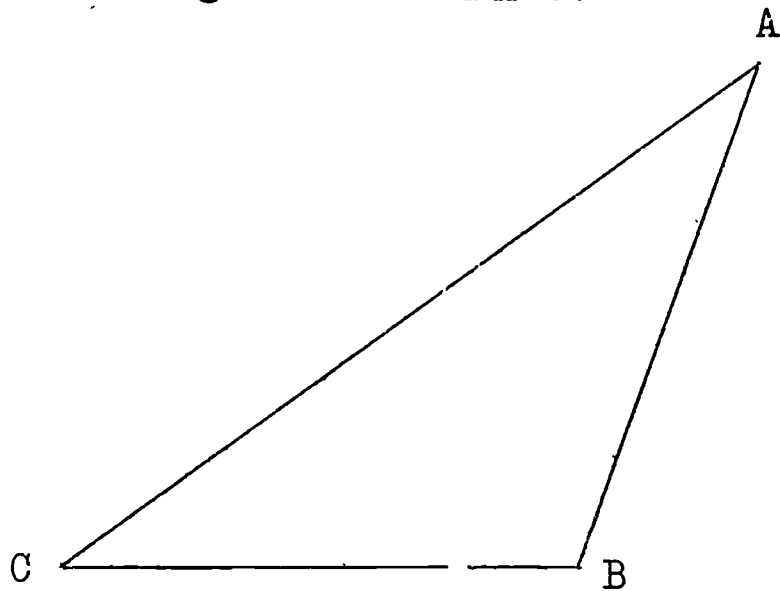

Follow the directions of Exercise 3(a) to (e) above, using this obtuse triangle. Must you extend \overline{BC} and \overline{AC} in order to draw the altitudes to them?

5. Given the following right $\triangle ABC$:

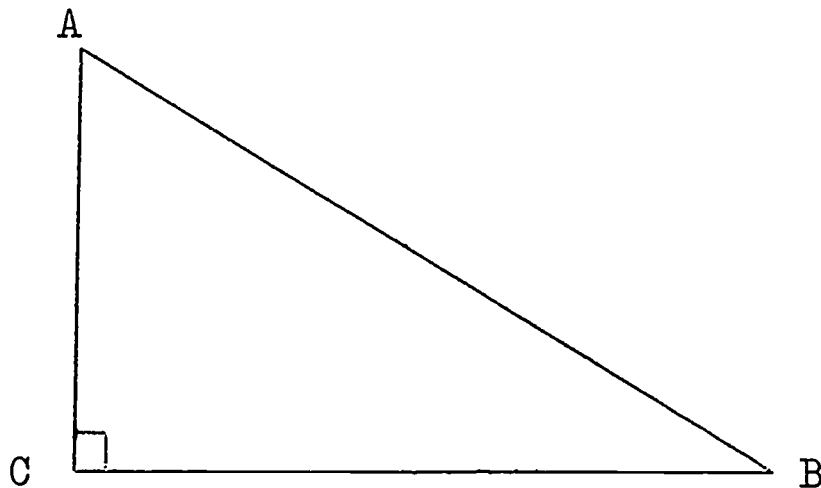

- Copy right $\triangle ABC$ into your notebook.
- Name two of the altitudes of $\triangle ABC$.
- Draw $\overline{CD} \perp \overline{AB}$, where D is on \overline{AB} .
- Do the three altitudes of $\triangle ABC$ intersect in exactly one point? Where is this point of intersection?

4-3 Straightedge and Compass

Can you make some constructions using only a straightedge and compass? For example, can you construct a triangle all of whose sides have equal measure? Here is how you can do this construction:

Class Activity

To Construct an Equilateral Triangle

On the next page are the pictures and steps which you should follow in order to construct an equilateral triangle.

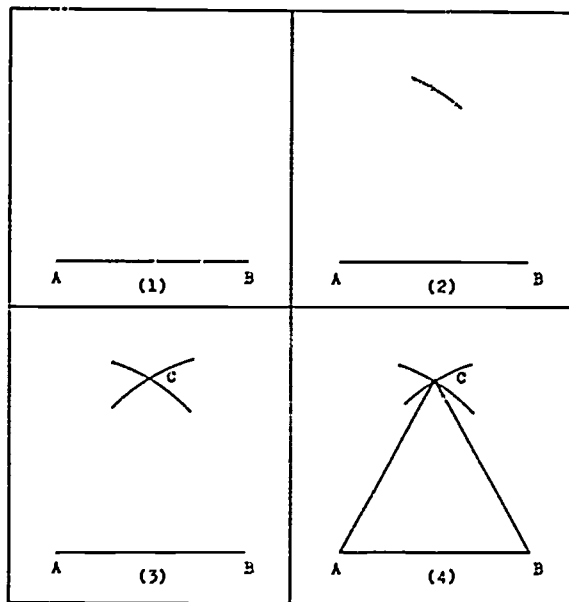

(1)

1. Draw \overline{AB} 2 inches long.
2. With A as centre, and radius \overline{AB} , draw an arc.
3. With B as centre, and the same radius, draw another arc intersecting the first arc at point C.
4. Draw \overline{CA} and \overline{CB} .

.....

In figure (I,4), what kind of triangle is $\triangle ABC$? Have you constructed all sides of the same measure ? Are the sides congruent to each other ? What is the measure of $\angle A$? of $\angle B$? of $\angle C$? While constructing an equilateral triangle, you have constructed an angle of 60° without using your protractor !

Throughout the rest of this Chapter, we shall make our constructions with only a straightedge and a compass. We shall use a ruler and a protractor to measure line segments and angles only after they have been drawn.

4-4 To Draw the Perpendicular to a Line Through a Point On the Line

Class Activity

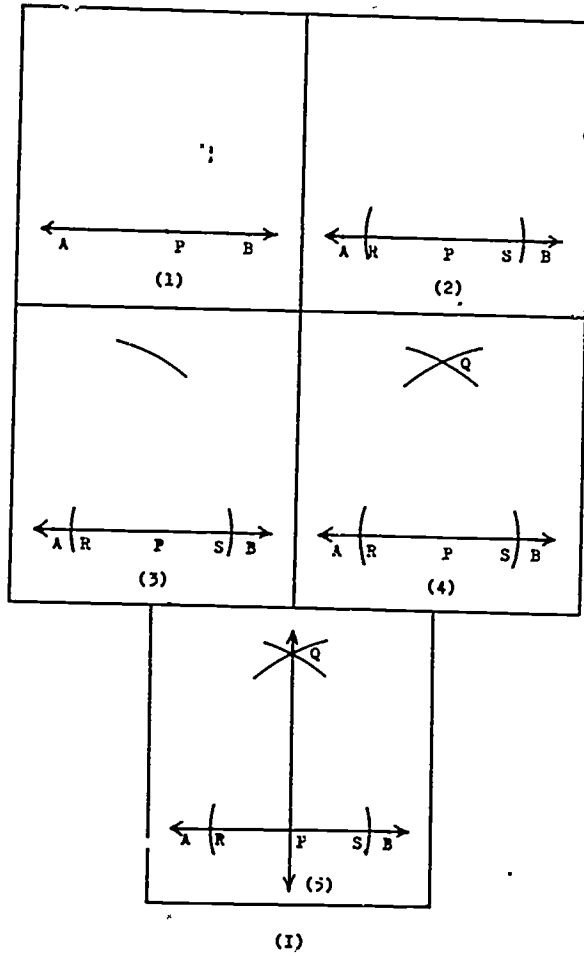

1. Draw \overleftrightarrow{AB} , and let P be any point on \overleftrightarrow{AB} .
2. With P as centre, and any convenient radius, draw two arcs intersecting \overleftrightarrow{AB} at R and S.
3. With S as centre, and with any convenient radius greater than one-half of $m\overline{RS}$, draw an arc.
4. With R as centre, and the same radius, draw another arc intersecting the first arc at Q.
5. Draw \overleftrightarrow{PQ} .

.....

In figure (I,5) above, if we draw \overline{QR} and \overline{QS} , the picture would look like this:

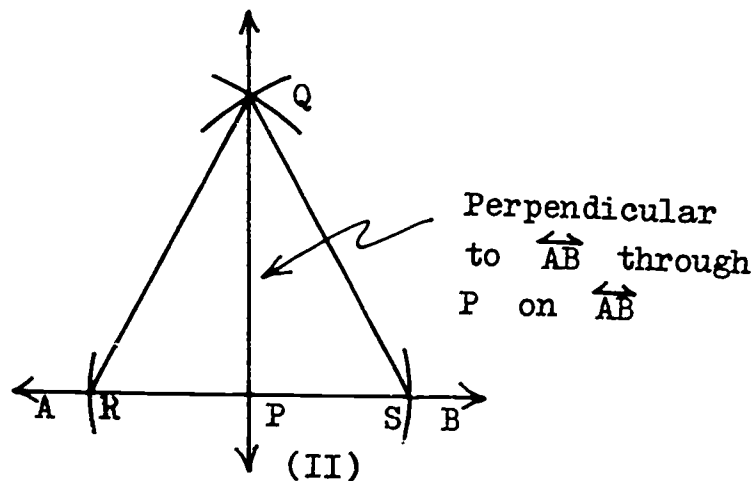

In figure (II), $\overline{QR} \cong \overline{QS}$ Congruent radii
 $\overline{PR} \cong \overline{PS}$ Why ?
 $\overline{QP} \cong \overline{QP}$ Why ?

Therefore, $\triangle QRP \cong \triangle QSP$ Why ?
 and $\angle QPR \cong \angle QPS$ Why ?

But $\angle QPR$ is supplementary to $\angle QPS$.
 Hence, $\angle QPR$ is a right angle.

Therefore, $\overline{QP} \perp \overline{RS}$
 and $\overline{QP} \perp \overline{AB}$ Why ?

Triangle QRS is an isosceles triangle. \overline{RS} is called the base of the isosceles triangle. Notice that the base of an isosceles triangle is opposite the vertex included between the congruent sides.

P is the midpoint of the base \overline{RS} .

In an isosceles triangle, the segment drawn from the vertex to the midpoint of the base is perpendicular to the base.

This property of isosceles triangles should help you to understand why \overrightarrow{PQ} is perpendicular to \overline{AB} in figure (I,5).

Exercises 4-4

1. a. Let Q be any point on \overleftrightarrow{LM} . Through Q , draw $\overleftrightarrow{PQ} \perp \overleftrightarrow{LM}$, where P is on \overleftrightarrow{PQ} .
 - b. Let R be another point on \overleftrightarrow{LM} . Through R , draw $\overleftrightarrow{NR} \perp \overleftrightarrow{LM}$.
 - c. What can you say about \overleftrightarrow{PQ} and \overleftrightarrow{NR} ? Why?
2. Construct a line perpendicular to a line segment PQ at the point P using the method above. Must you extend \overline{QP} to do the construction? Why?
 3. Construct a square $ABCD$ with side of 2 inches using your straightedge and ruler.
 4. Construct a rectangle $EFGH$ such that $m \overline{EF} = 3$ (inches) and $m \overline{FG} = 5$ (cms.).

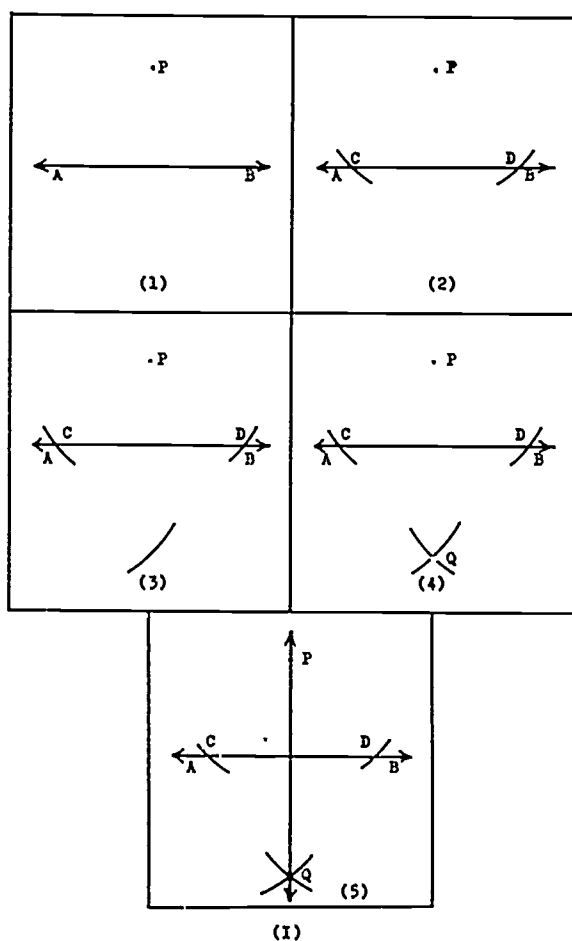
4-5 To Draw the Perpendicular to a Line Through a Point Not On the LineClass Activity

1. Draw \overleftrightarrow{AB} , and let P be a point not on \overleftrightarrow{AB} .
2. With P as centre, and with any radius greater than the distance from P to \overleftrightarrow{AB} , draw two arcs intersecting \overleftrightarrow{AB} at C and D .
3. With C as centre, and with any radius greater than one-half of $m\overline{CD}$, draw an arc on the opposite side of \overleftrightarrow{AB} from P .
4. With D as centre, and with the same radius as in Step 3, draw another arc intersecting the first arc at point Q .
5. Draw \overleftrightarrow{PQ} .

.....

In figure (I,5) above, if we draw \overline{CP} , \overline{DP} , \overline{QC} and \overline{QD} , the picture would look like this:

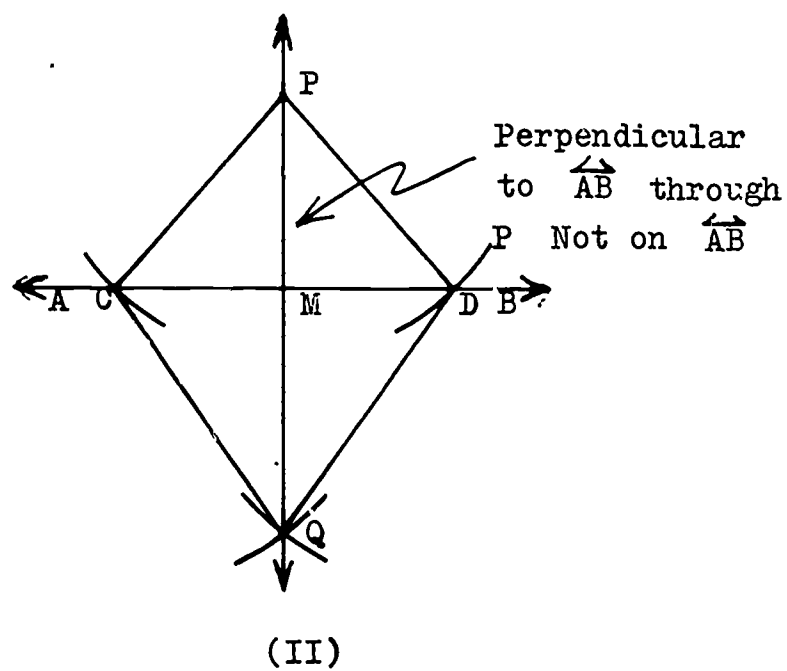

In figure (II), $\overline{CP} \equiv \overline{DP}$ Congruent radii
 $\overline{CQ} \equiv \overline{DQ}$ Why ?
 $\overline{PQ} \equiv \overline{PQ}$ Why ?

Therefore, $\triangle PCQ \equiv \triangle PDQ$ Why ?
 and $\angle CPQ \equiv \angle DPQ$ (5)

Now look at $\triangle CPM$ and $\triangle DPM$ in the isosceles $\triangle CPD$.

$\overline{PM} \equiv \overline{PM}$ Why ?
 $\angle CPM \equiv \angle DPM$ Step (5) above
 $\overline{CP} \equiv \overline{DP}$ Why ?

Therefore, $\triangle PMC \equiv \triangle PMD$ Why ?
 and $\angle PMC \equiv \angle PMD$ Why ?
 and $\overline{CM} \equiv \overline{DM}$ Why ?

What kind of angles are $\angle PMC$ and $\angle PMD$? What then is true of \overline{PM} and \overline{CD} ? of \overleftrightarrow{PQ} and \overleftrightarrow{AB} ?

Also notice that in the isosceles $\triangle CPD$, \overline{PM} connects the midpoint of the base with the opposite vertex. Therefore,

$\overline{PM} \perp \overline{CD}$
 and $\overleftrightarrow{PQ} \perp \overleftrightarrow{AB}$.

In the Class Activity above, you have drawn \overleftrightarrow{PQ} perpendicular to \overleftrightarrow{AB} through P not on \overleftrightarrow{AB} .

Exercises 4-5

1. a. Draw \overleftrightarrow{AB} , and let P be any point not on \overleftrightarrow{AB} . Through P, draw $\overleftrightarrow{PQ} \perp \overleftrightarrow{AB}$, where Q is on \overleftrightarrow{PQ} .
- b. Let R be another point not on \overleftrightarrow{PQ} . Through R, draw $\overleftrightarrow{RS} \perp \overleftrightarrow{PQ}$, where S is on \overleftrightarrow{RS} .
- c. What can you say about \overleftrightarrow{RS} and \overleftrightarrow{AB} ?

2. a. Draw a line \overleftrightarrow{AB} , and let Q be any point not on \overleftrightarrow{AB} .
 b. With C as any point on \overleftrightarrow{AB} , and radius $m\overline{CP}$, draw two arcs, one on each side of \overleftrightarrow{AB} .
 c. With D as any point on \overleftrightarrow{AB} , and radius $m\overline{DP}$, draw two arcs intersecting the first two arcs at E and F .
 d. Draw \overleftrightarrow{EF} . What can you say about \overleftrightarrow{EF} and \overleftrightarrow{AB} ?

3. Given the following $\triangle ABC$:

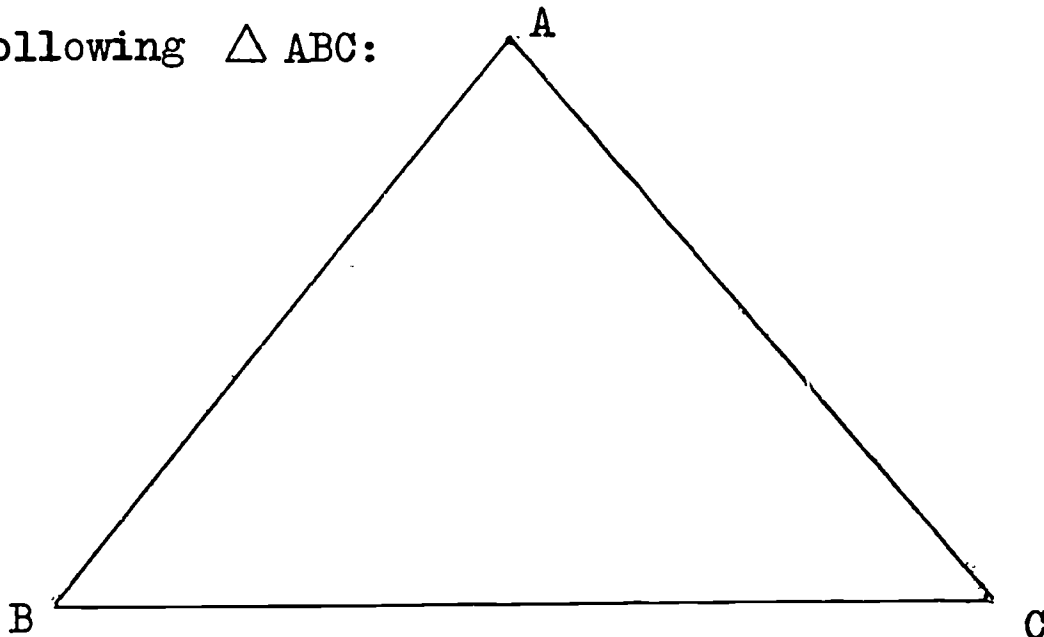

- a. Copy $\triangle ABC$ into your notebook.
 b. Recall that an altitude of a triangle is a line segment drawn from a vertex perpendicular to the line which contains the opposite side. Draw the three altitudes of $\triangle ABC$.
 c. What do you notice about the intersection of your three altitudes?
 d. Is the intersection in the interior of $\triangle ABC$?
4. Given the following obtuse $\triangle ABC$:

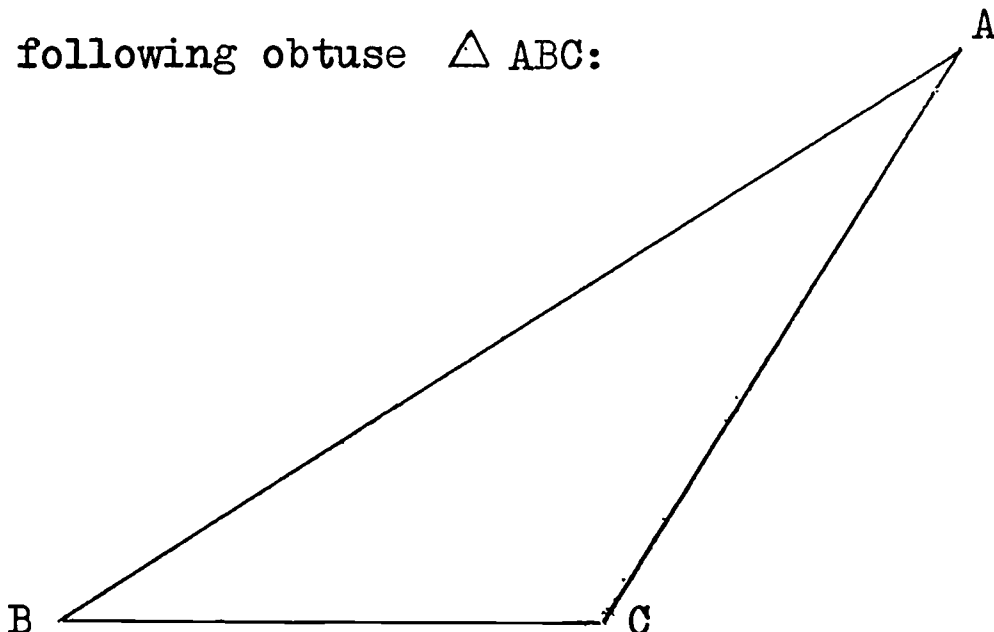

- a. Copy obtuse $\triangle ABC$ into your notebook, and follow the directions of Exercise 3b - d on the previous page. Must you extend sides \overline{AB} and \overline{CB} ?
- e. Is your answer in parts 3d and 4d the same ?

5. Given the right $\triangle ABC$:

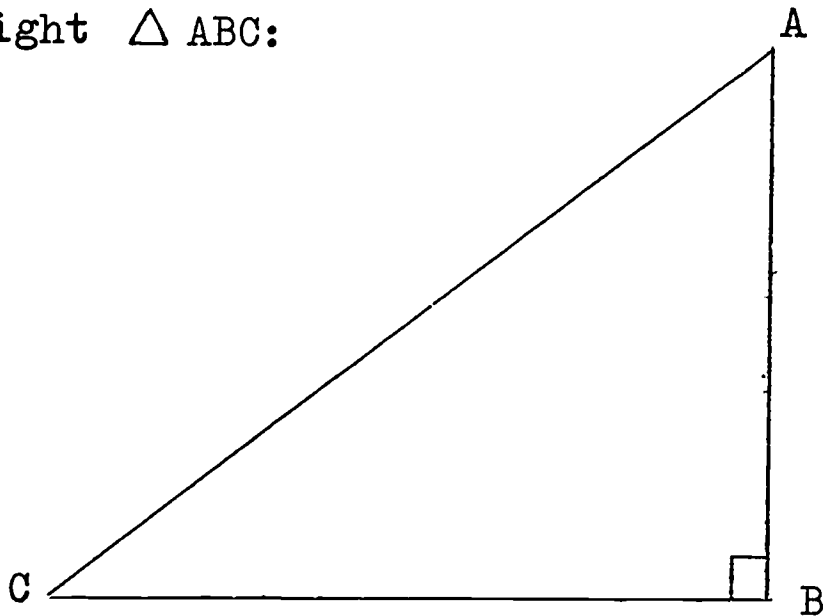

- a. Copy right $\triangle ABC$ into your notebook.
- b. What are two of the altitudes of $\triangle ABC$?
- c. Draw the third altitude of $\triangle ABC$.
- d. Do your three altitudes intersect in one point ? What is that point ?
- e. Is the point of intersection inside $\triangle ABC$? outside $\triangle ABC$? on $\triangle ABC$?
- f. Is your answer to parts 3d, 4d and 5e the same in each case ?

4-6 To Draw the Perpendicular Bisector of a Line Segment

Class Activity

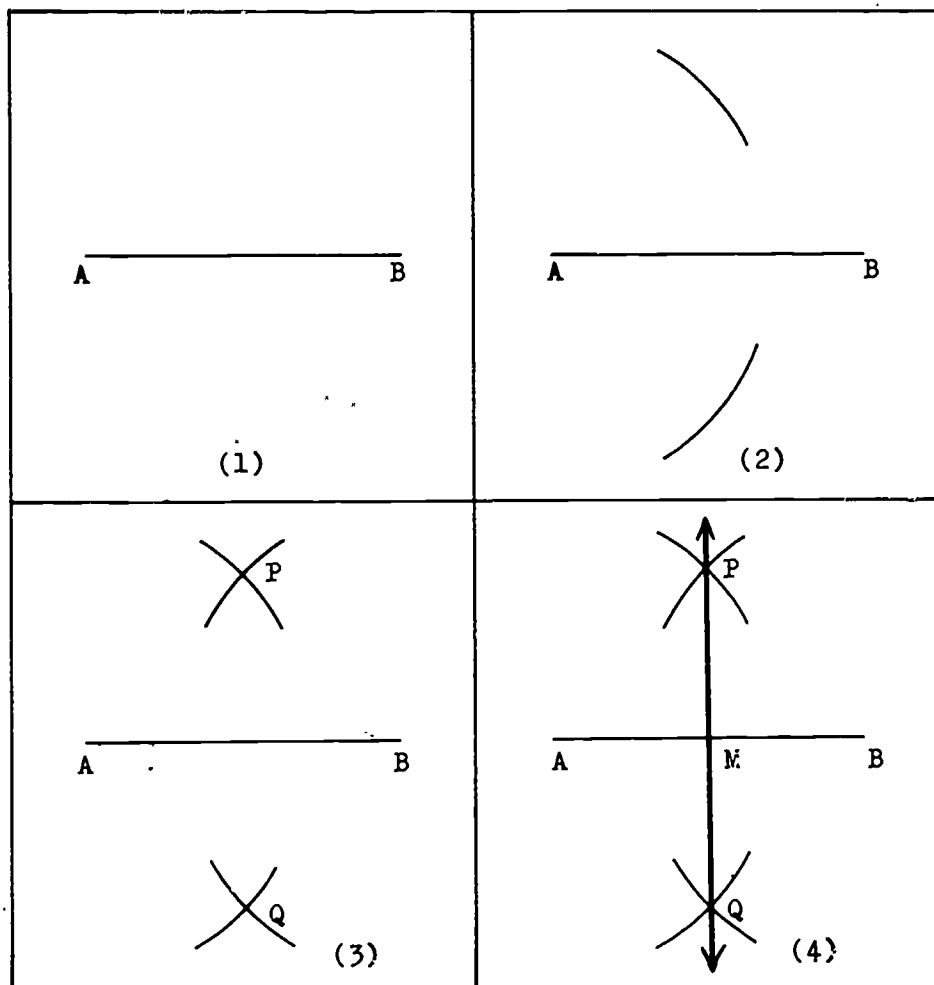

(I)

1. Draw \overline{AB} .
2. With A as centre, and radius more than one-half of $m \overline{AB}$, draw an arc on each side of \overline{AB} .
3. With B as centre, and the same radius, draw two arcs intersecting the first two arcs at points P and Q.
4. Draw \overleftrightarrow{PQ} , where \overleftrightarrow{PQ} intersects \overline{AB} at M.

.....

In figure (I,4) on the previous page, if we draw \overline{AP} , \overline{BP} , \overline{AQ} and \overline{BQ} , the picture would look like this:

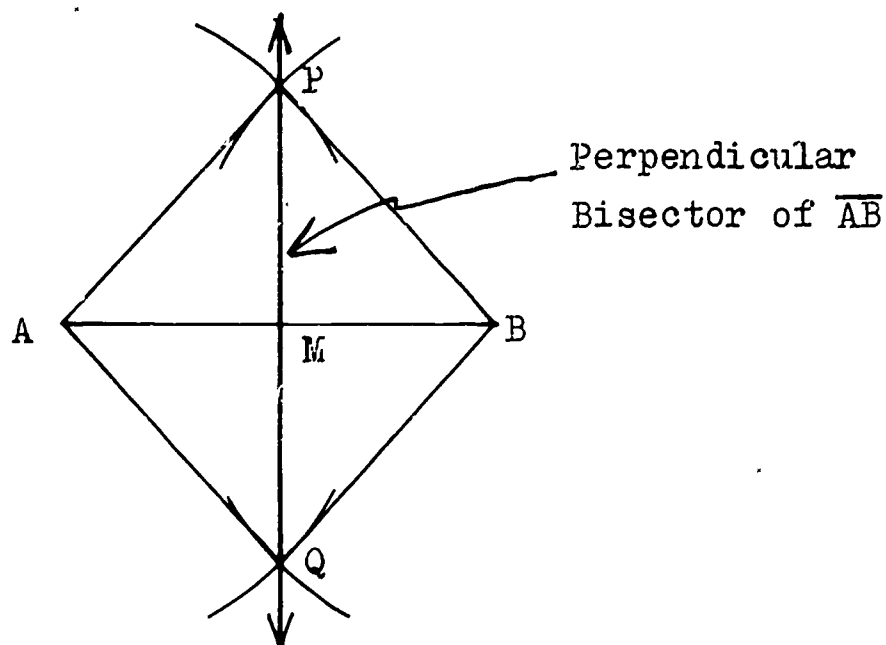

(II)

In figure (II), $\overline{AP} \cong \overline{BP}$.Congruent radii
 $\overline{AQ} \cong \overline{BQ}$ Why ?
 $\overline{PQ} \cong \overline{PQ}$ Why ?

Therefore, $\triangle APQ \cong \triangle BPQ$ Why ?
 and $\angle APM \cong \angle BPM$ Why ?

Now look at $\triangle APM$ and $\triangle BPM$ in the isosceles $\triangle APB$.

$\overline{AP} \cong \overline{BP}$
 $\angle APM \cong \angle BPM$
 $\overline{PM} \cong \overline{PM}$

Therefore, $\triangle APM \cong \triangle BPM$ Why ?
 Hence, $\angle AMP \cong \angle BMP$ Why ?
 and $\overline{AM} \cong \overline{BM}$ Why ?

What kind of angles are $\angle AMP$ and $\angle BMP$? What then can you say about \overline{PM} and \overline{AB} ? about \overleftrightarrow{PQ} and \overline{AB} ? What is M ?

Notice again that in the isosceles $\triangle APB$, \overline{PM} connects the midpoint of the base with the opposite vertex. Therefore,

$\overline{PM} \perp \overline{AB}$
 and $\overleftrightarrow{PQ} \perp \overleftrightarrow{AB}$.

In the Class Activity on page 197, you drew \overleftrightarrow{PQ} to be perpendicular to \overline{AB} , and \overleftrightarrow{PQ} to bisect \overline{AB} . Hence, you have drawn the perpendicular bisector of \overline{AB} .

Exercises 4-6

1. Using your straightedge and compass, draw the perpendicular bisector of:
 - a. \overline{CD} which is 3 inches long.
 - b. \overline{EF} which is 6 cms. long.
2. Divide a line segment 4 inches long into four equal parts using only your straightedge and compass.
3. Given the following $\triangle ABC$:

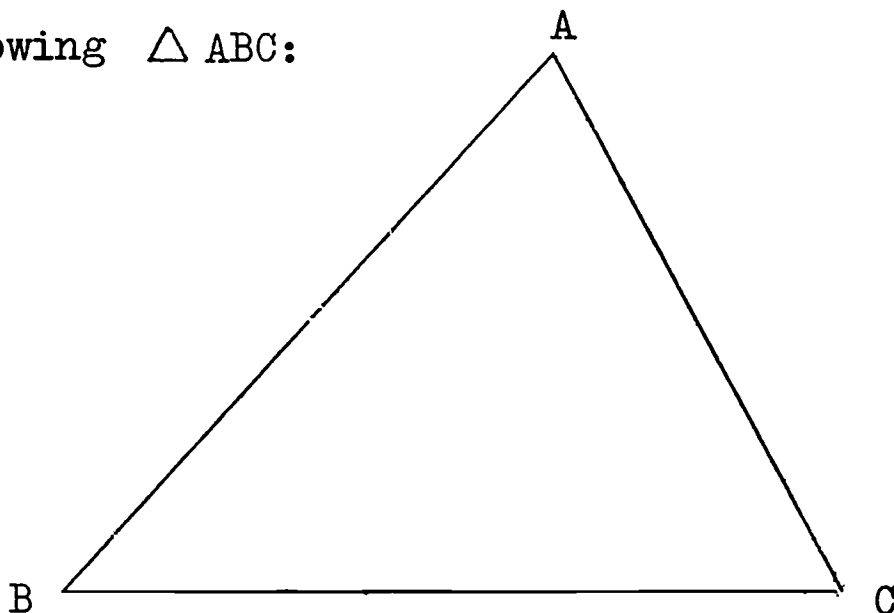

- a. Copy $\triangle ABC$ into your notebook.
- b. With straightedge and compass, draw the perpendicular bisectors of \overline{AB} , \overline{AC} and \overline{BC} .
- c. Do your three lines intersect in exactly one point? Call that point of intersection D.
- d. With D as centre, and \overline{AD} as radius, draw a circle.
- e. Does your circle contain points C and D?

4. Given the following obtuse $\triangle ABC$:

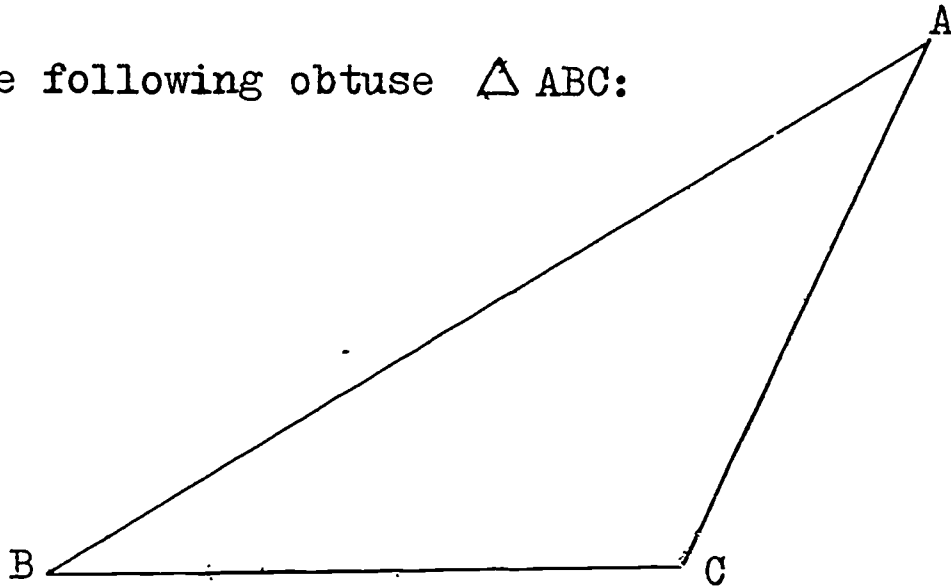

Copy this obtuse $\triangle ABC$ into your notebook, and follow the directions of Exercise 3 a - e on the previous page.

5. a. Draw \overline{AB} 2 inches long.
 b. With centre at A, and a radius of 3 inches, draw two arcs, one on either side of \overline{AB} .
 c. With centre at B, and the same radius, draw two arcs intersecting the first two arcs at points C and D.
 d. Draw \overline{CD} , intersecting \overline{AB} at M.
 e. What kind of polygon is ACBD? Why?
 f. What can you say about the diagonals of ACBD?
6. a. Draw \overline{AB} 3 inches long.
 b. With centre at A, and radius of 2 inches, draw two arcs, one on each side of \overline{AB} .
 c. With centre at B, and radius 3.5 inches, draw two arcs intersecting the first two arcs at C and D.
 d. Draw \overline{CD} , where \overline{CD} intersects \overline{AB} at M.
 e. Is $\overline{CD} \perp \overline{AB}$? Is M the midpoint of \overline{AB} ? Is \overline{CD} the perpendicular bisector of \overline{AB} ?

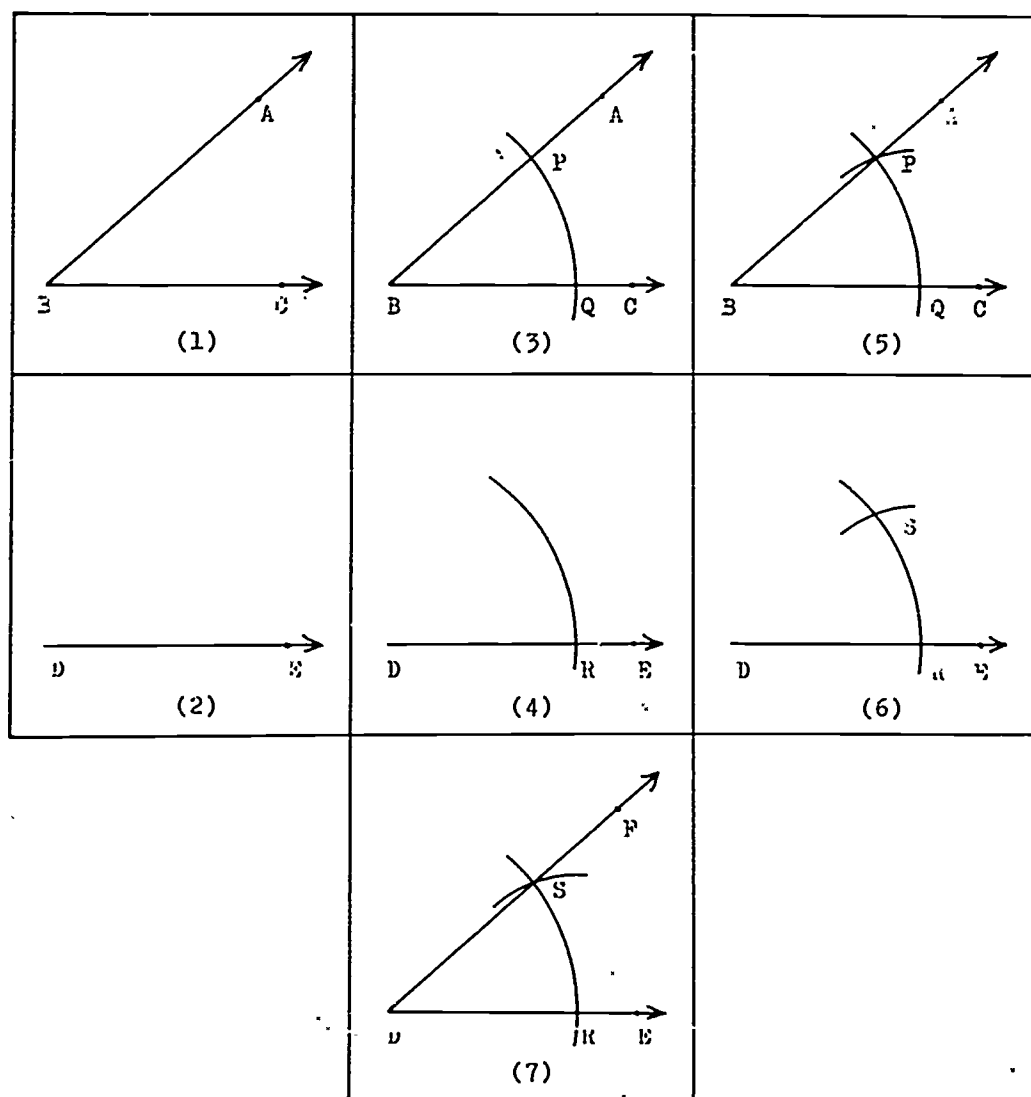
4-7 To Copy An AngleClass Activity

(I)

1. Draw any $\angle ABC$.
2. Draw \overrightarrow{DE} apart from $\angle ABC$.
3. With B as centre, and with any convenient radius, draw an arc intersecting \overrightarrow{BA} at P and \overrightarrow{BC} at Q.
4. With D as centre, and the same radius, draw an arc intersecting \overrightarrow{DE} at R.
5. With Q as centre, draw an arc passing through point P.

6. With R as centre, and the same radius, draw an arc intersecting the first arc at point S.
7. Draw \overline{DS} .

.....

In figures (I,5) and (I,7) on the previous page, if we draw \overline{PQ} and \overline{SR} , the pictures would look like this:

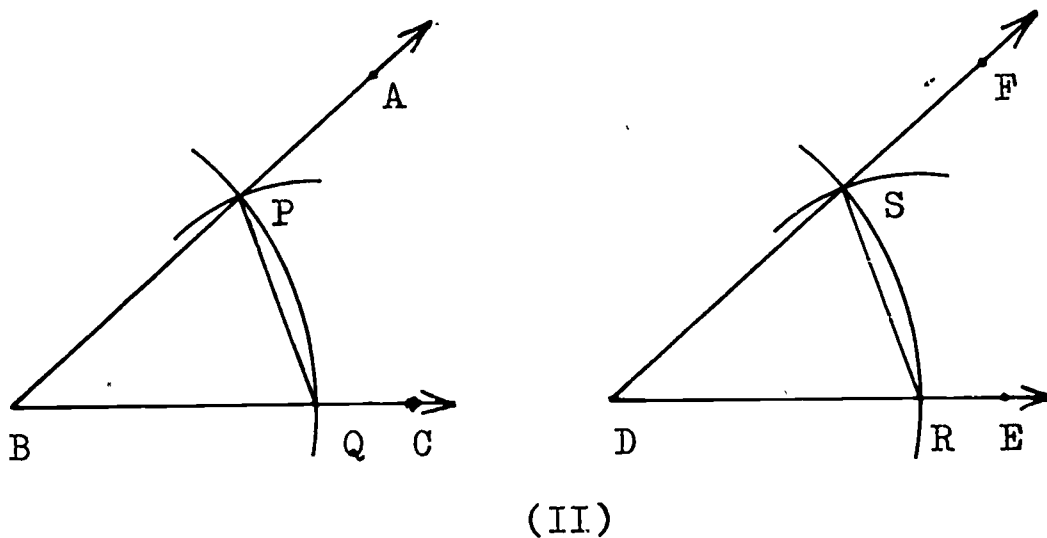

In figure (II), because points Q and R were determined by arcs having equal radii, we have:

$$\overline{BQ} \equiv \overline{DR} .$$

Also, $\overline{BP} \equiv \overline{DS}$ Why ?

and $\overline{PQ} \equiv \overline{SR}$ Why ?

Therefore, $\triangle PBQ \equiv \triangle SDR$ Why ?

Hence, $\angle B \equiv \angle D$ Why ?

In the Class Activity above, you have drawn

$$\angle FDE \equiv \angle ABC .$$

Hence, you have copied the angle ABC.

Exercises 4-7

1. Use your protractor to draw each angle whose measure is given, then copy each angle:

a. 24

c. 60

e. 107

b. 30

d. 82

f. 156

Check the accuracy of your construction by measuring each angle you constructed with your protractor.

2. Given the following triangle: ABC :

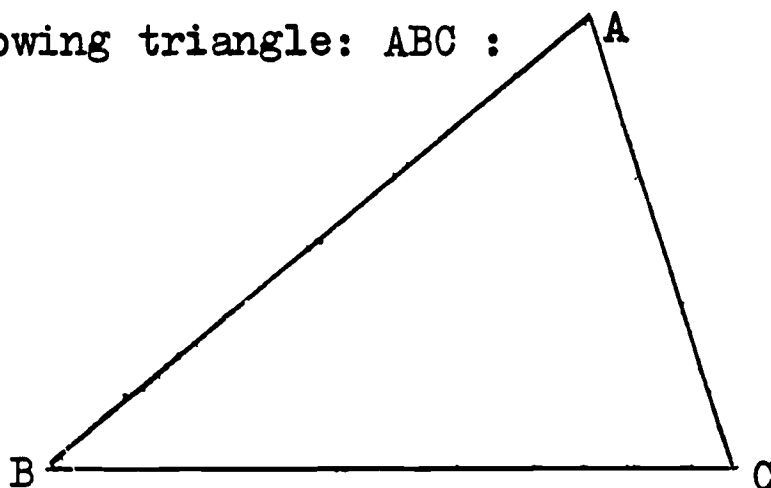

Using your straightedge and compass, copy $\triangle ABC$ into your notebook. Must you first copy one of the sides of $\triangle ABC$?

3. Given the following triangle DEF:

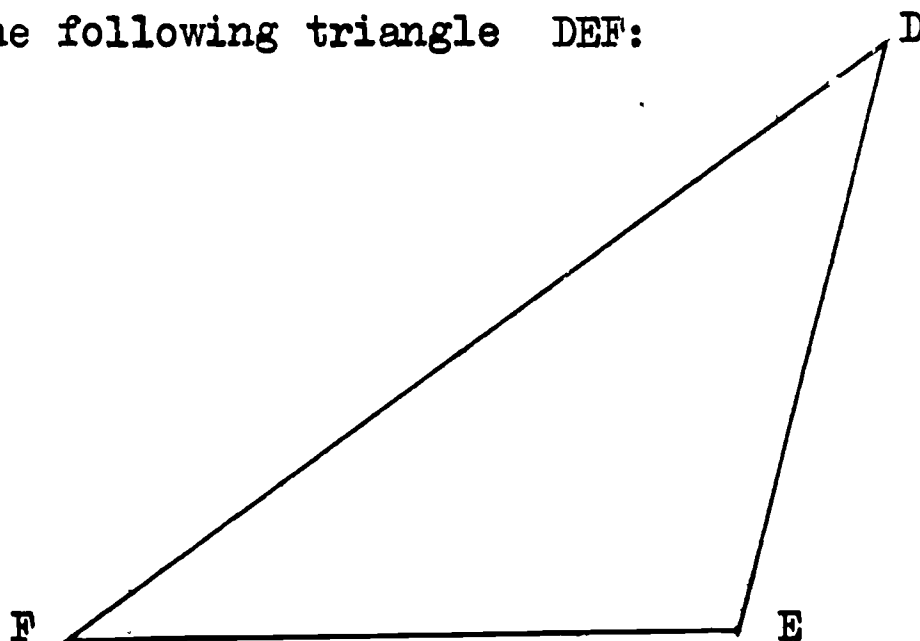

Using your straightedge and compass, copy $\triangle DEF$ into your notebook.

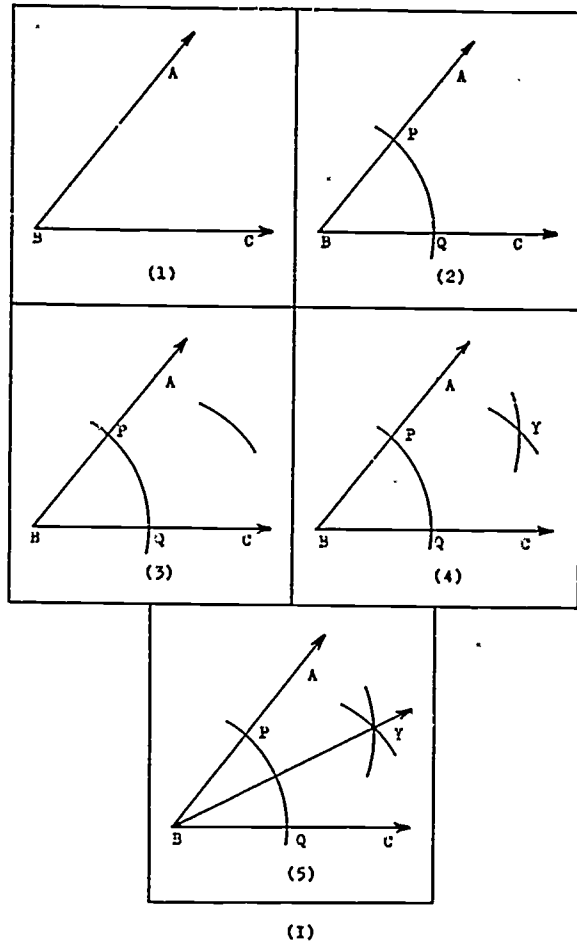
4-8 To Bisect An AngleClass Activity

1. Draw any $\angle ABC$.
2. With B as centre, and with any convenient radius, draw an arc intersecting \overline{BA} at P and \overline{BC} at Q.
3. With P as centre, and with any radius greater than one-half of $m\overline{PQ}$, draw an arc in the interior of $\angle ABC$.
4. With Q as centre, and with the same radius as in Step 3, draw an arc intersecting the first arc at Y.
5. Draw \overline{BY} .

.....

In figure (I,5) on the previous page, if we draw \overline{PY} and \overline{QY} , the figure would look like this:

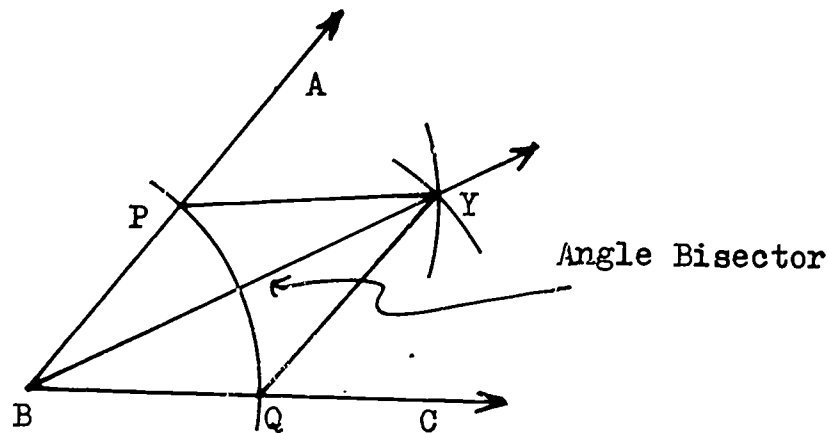

(II)

In figure (II), because points P and Q were determined by the same arc, we have:

$$\overline{BP} \equiv \overline{BQ} .$$

Because point Y was determined by arcs having equal radii, we know that:

$$\overline{PY} \equiv \overline{QY} .$$

Also, $\overline{BY} \equiv \overline{BY}$ Why ?

Therefore, $\triangle BPY \equiv \triangle BQY$ Why ?

Hence, $\angle PBY \equiv \angle QBY$ Why ?

In the Class Activity above, you have drawn

$$\angle ABY \equiv \angle CBY .$$

Hence, you have bisected $\angle ABC$ with \overline{BY} .

Exercises 4-8

1. a. With your protractor, draw angles with the following measures:

(i) 30

(iii) 90

(v) 120

(ii) 60

(iv) 45

(vi) 180

- b. With your straightedge and compass, bisect each angle in part (a) on the previous page.
- c. Check the accuracy of your bisections by measuring with your protractor.
2. a. With straightedge and compass, construct $\angle ABC$ such that $m \angle ABC = 90$.
- b. Draw \overline{BD} such that \overline{BD} bisects $\angle ABC$. $m \angle ABD = ?$
 $m \angle CBD = ?$
3. a. With straightedge and compass, construct $\angle DEF$ such that $m \angle DEF = 60$. Recall that you constructed an angle of 60° when you constructed an equilateral triangle.
- b. Draw \overline{EG} such that \overline{EG} bisects $\angle DEF$. $m \angle DEG = ?$
4. Given the following construction:

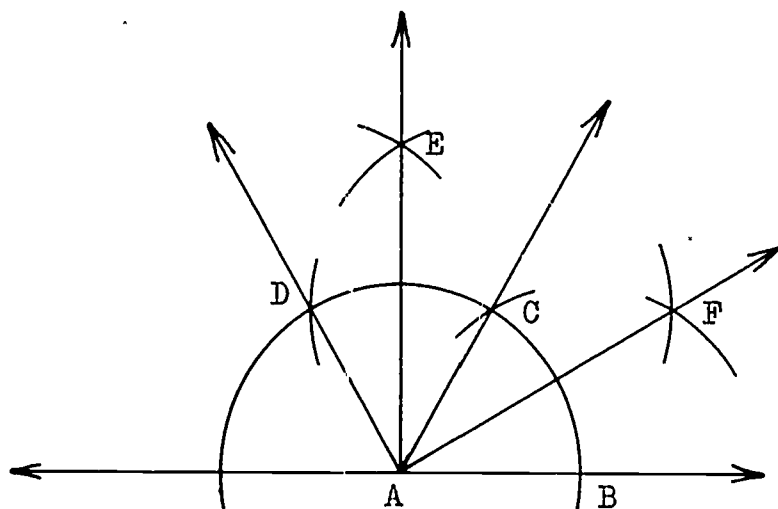

- a. Copy this construction into your notebook using your straightedge and compass.
- b. $m \angle BAC = ?$ Have you constructed a 60° by another method using only your straightedge and compass?
- c. $m \angle BAD = ?$ Have you constructed an angle of 120° using straightedge and compass?
- d. $m \angle BAE = ?$ Have you constructed a 90° angle using straightedge and compass? Is $\overline{AE} \perp \overline{AB}$?

e. $m \angle BAF = ?$ Have you constructed a 30° angle using your straightedge and compass?

f. Do \overline{AC} and \overline{AF} trisect $\angle BAE$?

5. Given the following $\triangle ABC$:

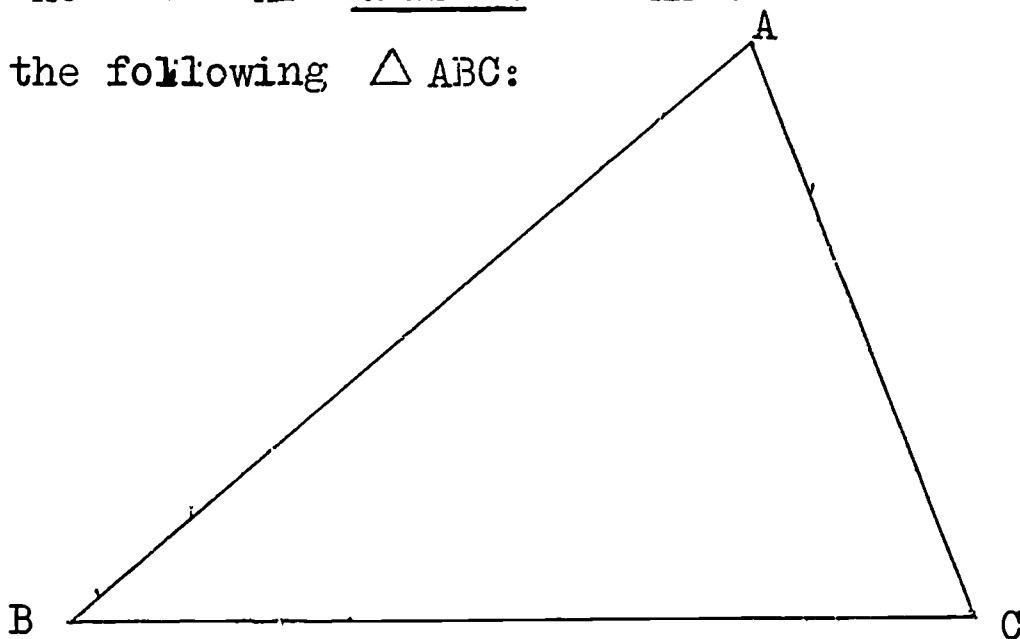

a. Copy $\triangle ABC$ into your notebook.

b. Construct the three angle bisectors of $\triangle ABC$.

c. Do your three angle bisectors intersect in exactly one point? Call that point D.

d. Construct \overline{DE} perpendicular to \overline{BC} , with E on \overline{BC} .

e. With D as centre, and \overline{DE} as radius, draw a circle.

f. What do you observe about the circle?

6. Given the following obtuse triangle ABC:

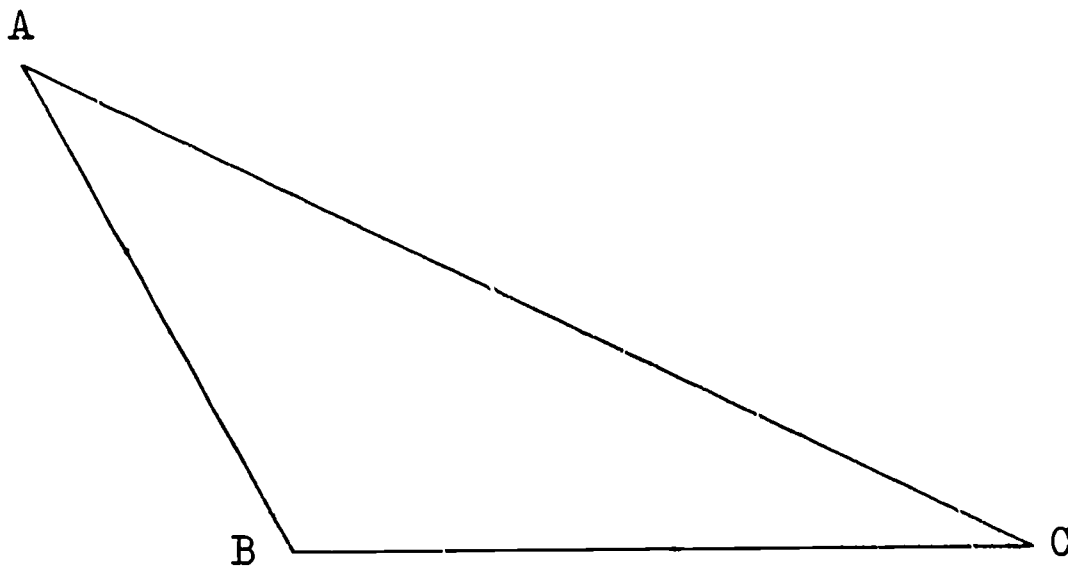

Copy this obtuse $\triangle ABC$ into your notebook, and follow the directions of Exercise 5a - f above, using this triangle.

4-9 To Draw a Line Parallel to a Given Line Through a Given Point Not On That Line

Class Activity

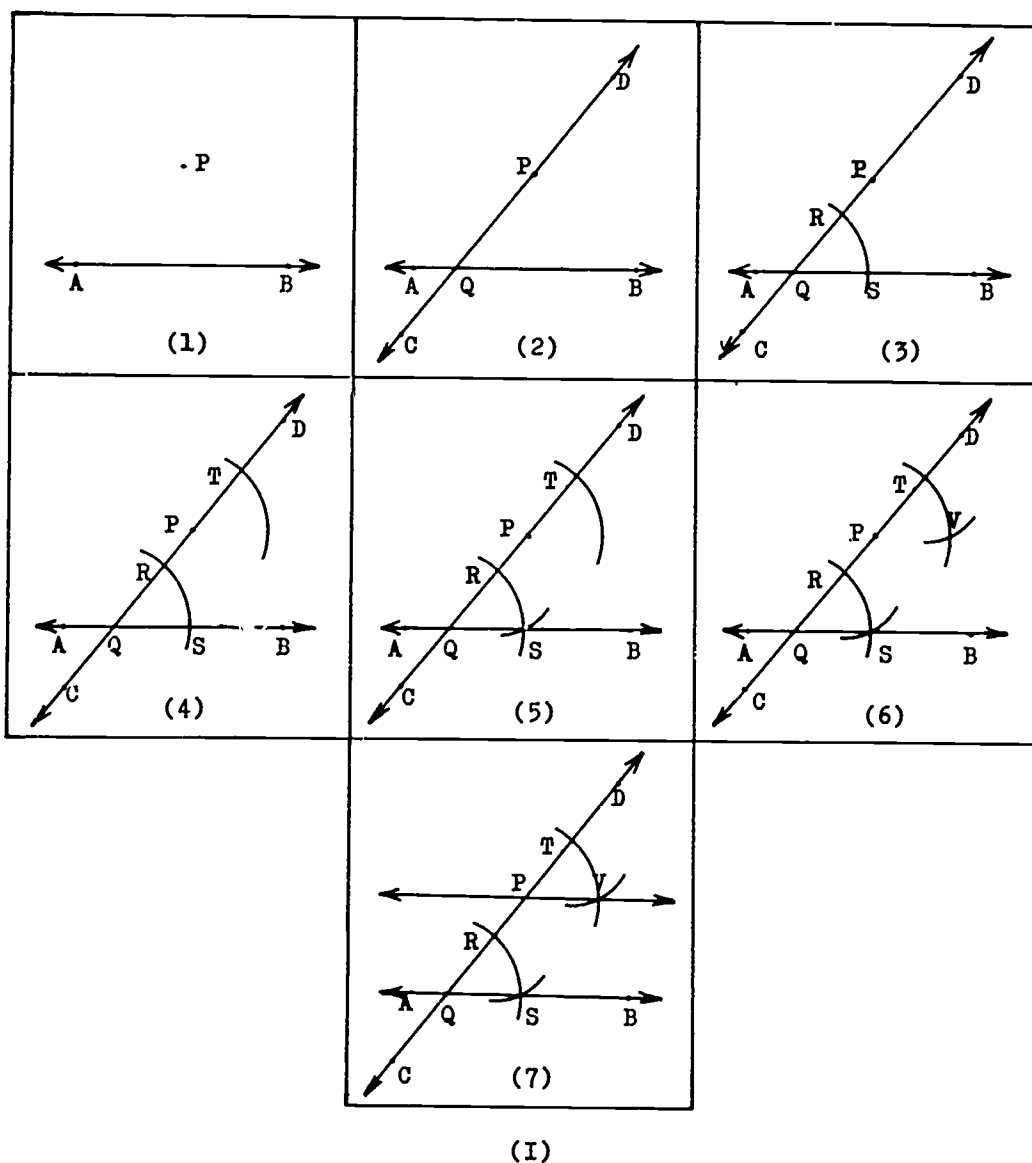

1. Draw \overrightarrow{AB} , and let P be any point not on \overrightarrow{AB} .
2. Through P , draw any line \overrightarrow{CD} intersecting \overrightarrow{AB} at Q .
3. With centre at Q , and with any convenient radius, draw an arc intersecting \overrightarrow{CD} at R , and \overrightarrow{AB} at S .
4. With P as centre, and the same radius, draw an arc intersecting \overrightarrow{QP} at T .

5. With R as centre, draw an arc passing through point S.
6. With T as centre, and the same radius as Step 5, draw an arc intersecting the arc of Step 5 at V.
7. Draw \overleftrightarrow{PV} .

.....

In figure (I,7) above, if we drew \overline{TV} and \overline{RS} , the figure would look like this:

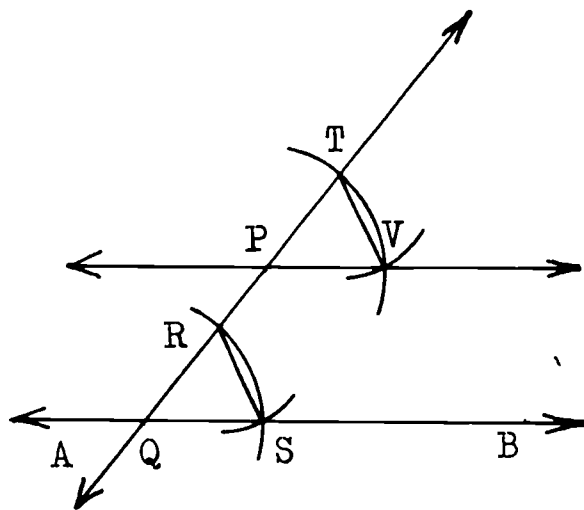

(II)

In figure (II), $\overline{QS} \equiv \overline{PV}$ Congruent radii
 $\overline{QR} \equiv \overline{PT}$ Why ?
 $\overline{RS} \equiv \overline{TV}$ Why ?

Therefore, $\triangle QRS \equiv \triangle PTV$ Why ?
 and $\angle TPV \equiv \angle RQS$ Why ?

What are angles TPV and RQS called ?

If two lines are cut by a transversal such that the corresponding angles are congruent, then the two lines are parallel.

In the Class Activity above, you have drawn a line parallel to a given line through a given point not on that line.

Exercises 4-9

1. Draw \overline{AB} 2 inches long.
 - b. Draw \overline{DA} 1.5 inches long such that $m \angle DAB = 36^\circ$.
 - c. Complete the parallelogram $ABCD$ using only straightedge and compass.
2. Construct a rhombus of side 2 inches and one angle of 40° .
3.
 - a. Draw any $\triangle ABC$.
 - b. Locate the midpoint M of side \overline{AB} by constructing the perpendicular bisector of \overline{AB} .
 - c. Through M , draw a line parallel to \overline{BC} meeting \overline{AC} at N .
 - d. Measure \overline{AN} and \overline{NC} . What is true of these measures?
4.
 - a. Draw any quadrilateral $ABCD$.
 - b. Locate the midpoints of \overline{AB} , \overline{BC} , \overline{CD} and \overline{DA} by constructing the perpendicular bisectors. Call these points M , N , Q and R respectively.
 - c. Draw \overline{MN} , \overline{NQ} , \overline{QR} , and \overline{RM} .
 - d. What kind of figure is $MNQR$? Why?
5.
 - a. Draw any line AB .
 - b. Let P be any point not on \overleftrightarrow{AB} . Let Q be any point on \overleftrightarrow{AB} . Draw \overleftrightarrow{PQ} .
 - c. Through P , draw $\overleftrightarrow{PR} \parallel \overleftrightarrow{AB}$.
 - d. Let S be on \overleftrightarrow{PQ} such that $m \overline{QP} = m \overline{PS}$.
 - e. Draw $\overleftrightarrow{ST} \parallel \overleftrightarrow{PR}$. Is \overleftrightarrow{ST} also parallel to \overleftrightarrow{AB} ? Why?
 - f. Through S , draw another transversal \overleftrightarrow{SW} intersecting \overleftrightarrow{PR} at V , and \overleftrightarrow{AB} at W .
 - g. $m \overline{SV} = ?$ $m \overline{VW} = ?$ What is true of these measures?
Is $\overline{SV} \cong \overline{VW}$?
 - h. Through S , draw a third transversal \overleftrightarrow{SY} , intersecting \overleftrightarrow{PR} at X and \overleftrightarrow{AB} at Y .
 - i. $m \overline{SX} = ?$ $m \overline{XY} = ?$ What is true of these measures?
Is $\overline{SX} \cong \overline{XY}$?
 - j. Do you think that if any transversal is drawn, that the segments intersected by \overleftrightarrow{ST} , \overleftrightarrow{PR} and \overleftrightarrow{AB} will be congruent? Try to draw a transversal for which this is not true.

4-10 Construction of Triangles

A. To Construct a Triangle, Given the Three Sides (SSS)

Suppose you wish to construct a triangle ABC in which

$$m \overline{AB} = 2 \text{ (inches)}$$

$$m \overline{BC} = 3 \text{ (inches)}$$

$$m \overline{CA} = 4 \text{ (inches)}$$

You should proceed as follows:

Class Activity

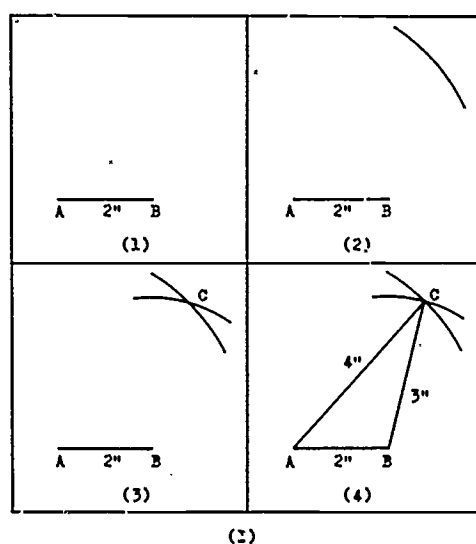

1. Draw \overline{AB} , such that $m \overline{AB} = 2$ (inches).
2. With centre at A, and radius 4 inches, draw an arc.
3. With centre at B, and radius 3 inches, draw another arc intersecting the first arc at C.
4. Draw \overline{CA} and \overline{CB} . $\triangle ABC$ is thus drawn.

.....

Is your triangle ABC congruent to all of the other triangles drawn in your class? Why?

B. To Construct a Triangle, Given Two Sides and the Included Angle (SAS)

Suppose you wish to construct $\triangle DEF$ in which

$$\begin{aligned} m \overline{DE} &= 2.0 && \text{(inches)} \\ m \angle EDF &= 35 && \text{(degrees)} \\ m \overline{DF} &= 1.5 && \text{(inches)} \end{aligned}$$

You should proceed as follows:

Class Activity

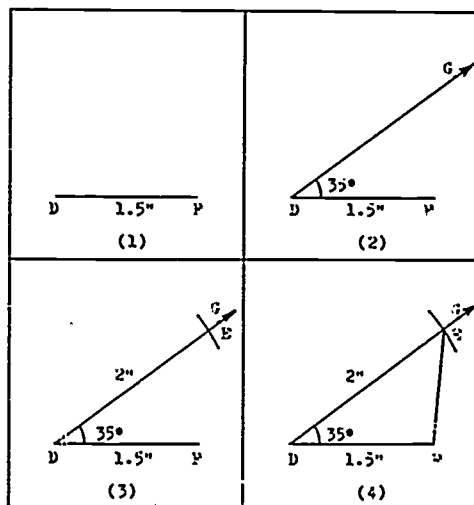

(II)

1. Draw \overline{DF} such that $m \overline{DF} = 1.5$ (inches).
2. Draw a ray \overrightarrow{DG} such that $m \angle GDF = 35$ (degrees).
3. With centre at D, and radius 2 inches, draw an arc intersecting \overrightarrow{DG} at E.
4. Draw \overline{EF} . $\triangle DEF$ is thus drawn.

.....

Is your $\triangle DEF$ congruent to your neighbour's? Why?

C. To Construct a Triangle, Given Two Angles and a Side
(ASA or AAS)

Suppose you wish to construct $\triangle JKL$ in which

$$m \angle J = 52 \quad (\text{degrees})$$

$$m \overline{JK} = 2.0 \quad (\text{inches})$$

$$m \angle K = 43 \quad (\text{degrees})$$

You should proceed as follows:

Class Activity

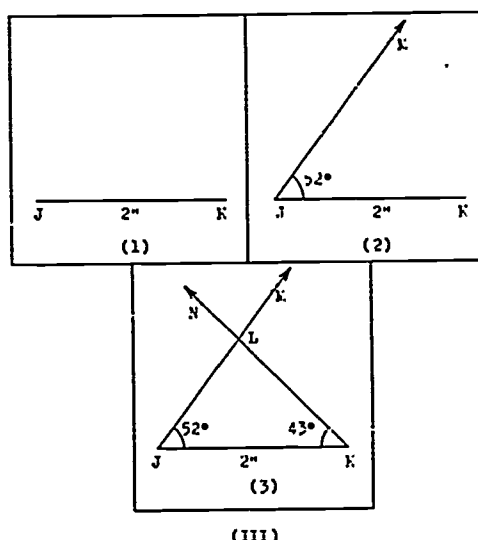

1. Draw \overline{JK} such that $m \overline{JK} = 2$ (inches).
2. Draw \overrightarrow{JM} such that $m \angle MJK = 52$ (degrees).
3. Draw \overrightarrow{KN} such that $m \angle NKJ = 43$ (degrees). Let \overrightarrow{JM} and \overrightarrow{KN} intersect at L. $\triangle JKL$ is thus drawn.

.....

Is your $\triangle JKL$ congruent to all of the other triangles drawn in your class? Why?

Exercises 4-10

1. Construct $\triangle DEF$ in which $m \overline{DE} = 2.5$ (in.), $m \angle DEF = 43$, and $m \angle FDE = 84$ (degrees).
2. Draw $\triangle ABC$ in which $m \overline{AB} = 3.0$, $m \overline{BC} = 2.5$, and $m \overline{CA} = 3.2$, where the unit of measure is inches.
3. Draw $\triangle GHI$ in which $m \overline{GH} = 3.5$ (in.), $m \overline{GI} = 2.6$ (in.) and $m \angle HGI = 58$ (degrees).
4. Draw $\triangle JKL$ in which $m \overline{JK} = 5.3$ (cms.), $m \overline{KL} = 7.2$ (cms.), and $m \overline{JL} = 4.7$ (cms.).
5. Draw $\triangle MNP$ in which $m \angle M = 63$, $m \angle N = 52$, and $m \overline{MP} = 6.4$ (cms.).
6. Construct $\triangle QRS$ in which $m \overline{QR} = 5.6$ (cms.), $m \overline{RS} = 6.2$ (cms) and $m \angle R = 47$ (degrees).

.....

Revision Test # 7

I. Fill in the blank with the correct word or number. Do your work in your notebook.

1. In making constructions, we use only _____ and _____.
2. In an isosceles triangle, one of the congruent angles has measure 24. The measure of the third angle is _____.
3. In an isosceles triangle, the angle opposite the base has measure 46. Each congruent angle has measure _____.
4. The triangles of your two set squares have angles whose measures are _____, _____, _____ and _____, _____, _____.

Use this figure to answer Questions 5, 6 and 7:

5. $m \angle c = \underline{\hspace{2cm}}$. $\overline{LM} \parallel \overline{PQ}$

6. $m \angle b = \underline{\hspace{2cm}}$. $m \angle a = 27$

7. $m \angle d = \underline{\hspace{2cm}}$.

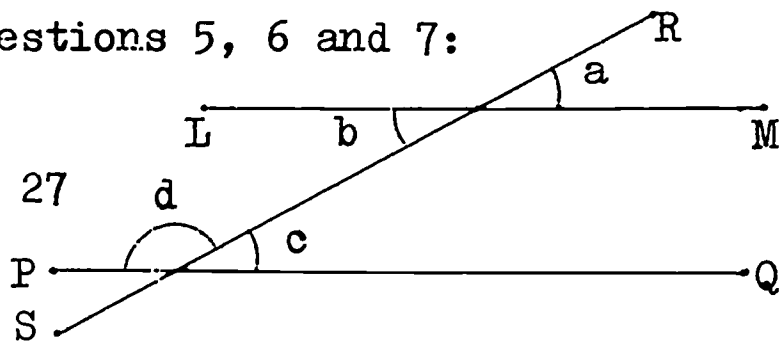

8. To draw an altitude of a triangle, you must construct the segment from a vertex to the opposite side.
9. A median of a triangle is a line segment from a to the of the opposite side.
10. You can find the midpoint of a line segment by constructing the of that segment.

II. Construct each of the following in your notebook, using straightedge and compass:

1.

a. Construct $\triangle ABC$ in which the sides are:

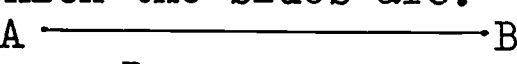
(i) $m \angle ACB = \underline{\hspace{2cm}}$ 

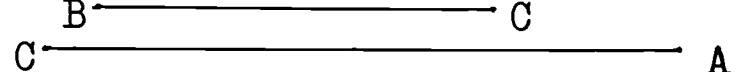
(ii) $m \angle BAC = \underline{\hspace{2cm}}$ 

b. In $\triangle ABC$, construct the perpendicular bisector of \overline{BC} .

2. a. Construct $\triangle RST$ such that $m \angle R = 90^\circ$, $m \overline{RS} = 6$ (cms.) and $m \overline{RT} = 8$ (cms.).

(i) $m \angle S = \underline{\hspace{2cm}}$.

(ii) $m \angle T = \underline{\hspace{2cm}}$.

b. In $\triangle RST$, construct the altitude from R to \overline{ST} .

3. a. Construct $\triangle XYZ$ by copying $\angle X$, $\angle Y$, and \overline{XY} into your notebook.

(i) $m \overline{XZ} = \underline{\hspace{2cm}}$.

(ii) $m \angle Z = \underline{\hspace{2cm}}$.

b. In $\triangle XYZ$, construct the bisector of $\angle Z$.

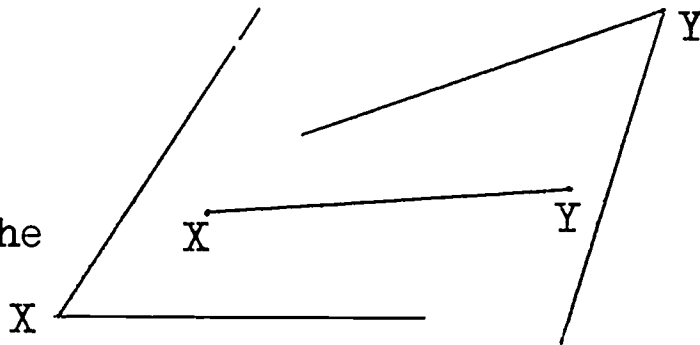

4. a. Construct an angle of measure 30° . Label the angle B. Complete $\triangle ABC$ such that $m \overline{AB} = 2$ (in.), $m \overline{BC} = 3$ (in.)

(i) $m \overline{CA} = \underline{\hspace{2cm}}$. (ii) $m \angle C = \underline{\hspace{2cm}}$.

b. Construct a line parallel to \overline{AB} through point C.

Cumulative Revision Test # 3

I. Fill in the blank with the correct phrase or number. Do your work in your notebook.

1. The sum of the measures of the angles in a triangle is _____.
2. A _____ is a quadrilateral with one pair of sides parallel.
3. A pentagon with 7 sides is _____.
4. A parallelogram with one right angle is a _____.
5. If all three sides of one triangle are congruent to _____ of another triangle, then the triangles are _____.
6. In $\triangle XYZ$, $\overline{XY} \perp \overline{YZ}$, $m\angle Z = 49$. $m\angle X =$ _____.
7. In parallelogram RSTU, $m\angle R = 67$. $m\angle S =$ _____.
8. A rhombus with one right angle is a _____.
9. Rectangle WXYZ has $\overline{WX} \cong \overline{XY}$. WXYZ is also a _____.
10. $\triangle KLM$ has $m\angle K = 110$ and $m\angle M = 34$. $m\angle L =$ _____.
11. A regular polygon has each exterior angle of measure 15. The polygon has _____ sides.
12. A hexagon RSTUXZ has $m\angle R = 100$ and $m\angle T = 110$.
 $m\angle S + m\angle U + m\angle X + m\angle Z =$ _____.
13. Two triangles are congruent if _____.
14. $\triangle RST \cong \triangle XYZ$, $m\angle X = 60$, $m\angle Y = 65$. $m\angle T =$ _____.
15. _____ of congruent triangles are congruent.
16. In quadrilateral ABCD, $\angle A \cong \angle B \cong \angle C \cong \angle D$. ABCD is a _____ or a _____.

17. A triangular region consists of a triangle and its _____ .

18. A circle is a _____ a given distance from a given _____ .

19. In circle T the radius is 4.5 inches. The diameter is _____ .

20. \overrightarrow{AB} is the _____ of the point A and the half-line containing point B.

II. Given the following figure in which:

$\overrightarrow{AE} \parallel \overrightarrow{BF}$, $\overrightarrow{EF} \parallel \overrightarrow{AB}$

$\overline{AB} \cong \overline{AC}$

$m \angle DAE = 70$

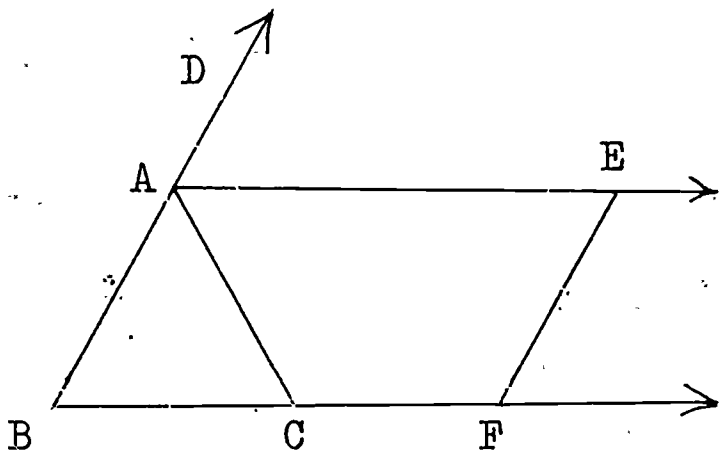

a. $\overline{BC} \cup \overline{CF} =$ _____

b. $\overline{AB} \cup \overline{AC} \cup \overline{BC} =$ _____

c. $\overline{AC} \cap \overline{BD} =$ _____

d. $m \angle FCA + m \angle EAC =$ _____

e. $\overrightarrow{AD} \cup \overrightarrow{BA} =$ _____

f. $\overrightarrow{AD} \cup \overrightarrow{AE} =$ _____

g. $\overrightarrow{CF} \cap \overrightarrow{AB} =$ _____

h. $\overrightarrow{BF} \cap \overrightarrow{BD} =$ _____

i. $\overrightarrow{AE} \cap \overrightarrow{BF} =$ _____

j. $m \angle B =$ _____

k. $m \angle BAE =$ _____

l. $m \angle ACB =$ _____

m. $m \angle EFB =$ _____

n. $m \angle BAC =$ _____

p. ABFE is a _____

1. $\overline{BC} \cup \overline{CF} = \overline{BCF}$, $\overline{AB} \cup \overline{AC} \cup \overline{BC} = \triangle ABC$
 2. $\overline{AC} \cap \overline{BD} = \overline{AC}$, $\overrightarrow{AD} \cup \overrightarrow{BA} = \overrightarrow{AD}$
 3. $\overrightarrow{AD} \cup \overrightarrow{AE} = \overrightarrow{AD}$, $\overrightarrow{CF} \cap \overrightarrow{AB} = \emptyset$
 4. $\overrightarrow{BF} \cap \overrightarrow{BD} = \overrightarrow{BF}$, $\overrightarrow{AE} \cap \overrightarrow{BF} = \overrightarrow{AE}$
 5. $m \angle B = 70$, $m \angle BAE = 70$, $m \angle ACB = 70$, $m \angle EFB = 70$, $m \angle BAC = 70$
 6. ABFE is a parallelogram

III. Answer A if the sentence is always true, S if the sentence is sometimes true, and N if the sentence is never true: Answer the questions in your notebook.

- _____ 1. If two sides and an angle of one triangle are congruent to the corresponding parts of another triangle, then the two triangles are congruent.
- _____ 2. A rhombus in which the measures of two consecutive angles add to 180 is a square.
- _____ 3. Parallelogram RSTU in which $\overline{RS} = \overline{ST}$ and $m\angle T = 90$ is a square.
- _____ 4. An acute triangle has exactly two acute angles.
- _____ 5. A scalene triangle can also be isosceles.
- _____ 6. Scalene $\triangle XYZ \cong \triangle RST$. $\overline{RS} \cong \overline{XZ}$.
- _____ 7. If a triangle has three angles and one side congruent to the corresponding parts of another triangle, then the two triangles are congruent.
- _____ 8. A parallelogram is a rhombus.
- _____ 9. A hexagon has each interior angle of measure 120.
- _____ 10. A square is a quadrilateral.
- _____ 11. A quadrilateral with two pairs of opposite sides parallel is a rectangle.
- _____ 12. The diagonals of a square are congruent.
- _____ 13. An isosceles trapezoid has one pair of congruent sides.

IV. Construct $\triangle RST$ such that $m\angle R = 45$, $m\angle S = 60$, and $m\overline{RS} = 2.5$ (inches).

Cumulative Revision Test # 4

I. Given the following pairs of triangles with congruent parts marked. If the triangles are congruent, give the reason. (ASA, SAS, etc.) If there is not enough information to decide, write No.

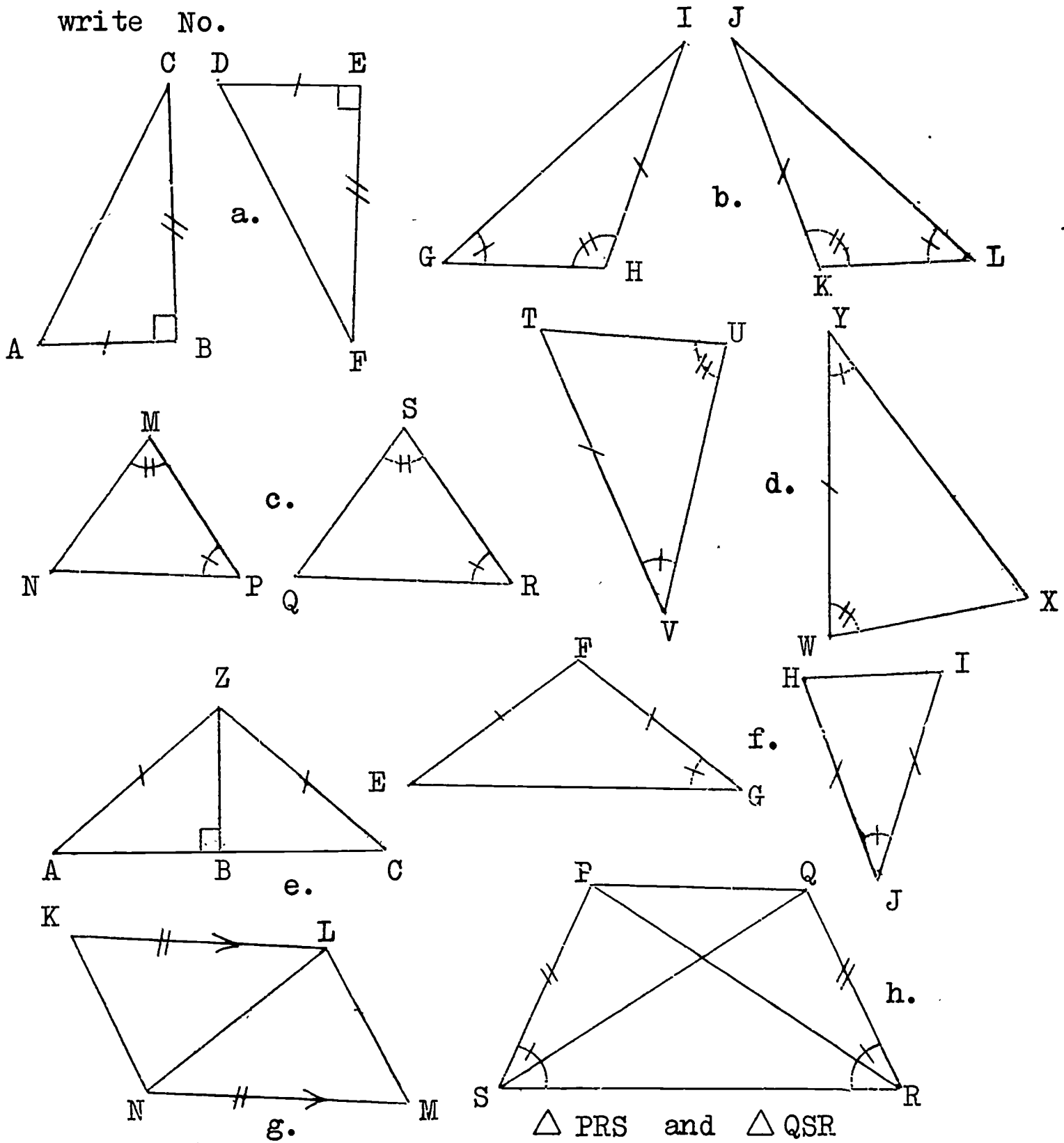

2. For each pair of congruent triangles in Question (1) above, write the correct correspondence of vertices.

II. Fill in the blank with the correct phrase or number. Do your work in your notebook.

1. The floor, the blackboard, and the top of your desk are all parts of _____ .
2. An angle separates a plane into three sets of points: the exterior, _____ , and _____ .
3. Two figures are _____ if one can be made to _____ on the other.
4. A segment AB is the set of all points _____ A and B , including _____ .
5. _____ angles have a common vertex, a common side, and no interior points in common.
6. Congruent line segments have _____ .
7. When two lines intersect, the opposite angles formed are called _____ .
8. Two triangles are congruent if all corresponding sides and _____ are _____ .
9. The symbol for ray RS is _____ .
10. If two sides and _____ of one triangle are congruent to _____ of another triangle, then _____ .
11. Two angles are _____ when the sum of their measures is 90 .
12. Points A , B and C all lie on the same line. Give three names for the line. _____; _____; _____ .
13. The instrument we use to measure angles is a _____ .
14. \overline{RS} is a line segment. $m \overline{RS}$ is a _____ .
15. $m \angle R = 70$. $m \angle S = 110$. $\angle R$ and $\angle S$ are called _____ angles.

III. Copy each picture into your notebook, then do the indicated constructions:

1. Construct the perpendicular from P to \overline{RS} .

2. a. Construct a triangle congruent to $\triangle XYZ$.

b. Bisect $\angle Z$.

c. Construct the median to \overline{XZ} .

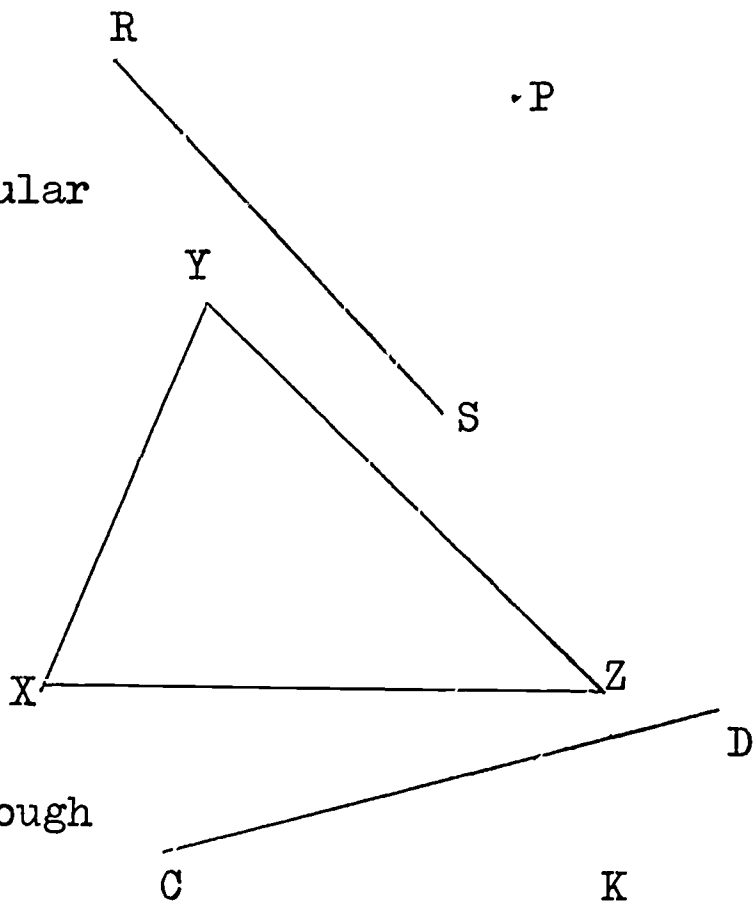

3. a. Construct a line through K which is parallel to \overline{CD} .

b. Mark point Z on your parallel line such that $\overline{DZ} \cong \overline{CK}$ and $\overline{KZ} \cong \overline{CD}$.

c. $\triangle CDK$ is a _____.

4. Construct $\triangle RST$ using the three given parts.

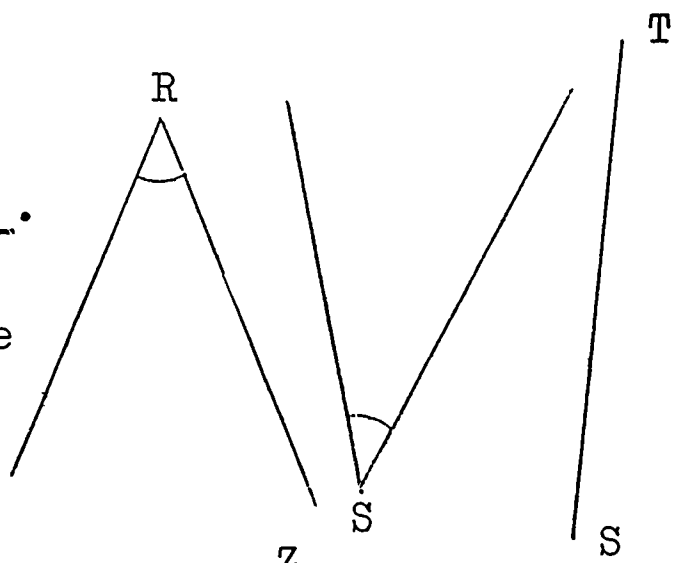

5. Construct the altitude from Z to \overline{XY} .

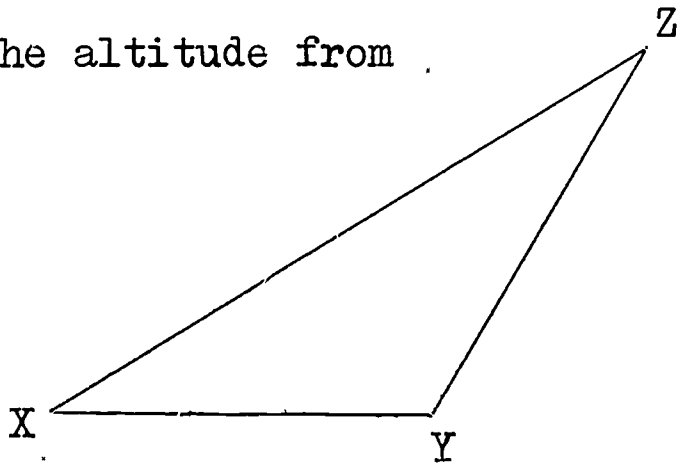

IV. Fill in the blank with the correct phrase or number. Do your work in your notebook.

1. The unit which is one-tenth of a centimetre is a _____.
2. A _____ is a plane figure which returns to the starting point and does not intersect itself.
3. \overline{RS} is a side of a polygon. Point S is a _____ of the polygon.
4. Two other names for $\triangle ABC$ are _____ and _____.
5. A simple closed curve made up of line segments is a _____.
6. The five cases of congruent triangles which you have studied are _____; _____; _____; _____; _____.
7. $\triangle ABC \cong \triangle STR$. $\overline{AC} \cong$ _____.
8. In an obtuse triangle, _____ angle(s) are obtuse.
9. An angle is the union of _____ with a _____.
10. A unit of angle measure is _____.
11. The sum of the measures of the interior angles of a _____ is 360.
12. Point T is on \overline{RS} such that $\overline{RT} \cong \overline{TS}$. T is the _____ of \overline{RS} .
13. Congruent triangles have _____ pairs of congruent parts.
14. The measure of a _____ angle is 180.
15. The supplement of an obtuse angle must be _____.
16. When two parallel lines are cut by a transversal, _____ angles have equal measures.
17. An obtuse angle has measure between _____ and _____.

.....