

DOCUMENT RESUME

ED 038 704

CG 005 263 .

AUTHOR Pober, Tommy L.; And Others
TITLE Software Documentation for the Bartlesville Public Schools: Part One. The Bartlesville System Total Guidance Information Support System.
INSTITUTION Bartlesville Public Schools, Okla.; Oklahoma State Univ., Stillwater.
REPORT NO TGISS-1
PUB DATE Jan 70
GRANT OEG-7-8-005685-0030(056)
NOTE 154p.

EDRS PRICE EDRS Price MF-\$0.75 HC-\$7.80
DESCRIPTORS *Computer Programs, *Computer Storage Devices, Confidential Records, *Counseling Effectiveness, Information Processing, Information Retrieval, Information Systems, *Man Machine Systems, *Performance Specifications, Pupil Personnel Services, Student Records
IDENTIFIERS Total Guidance Information Support System (TGISS)

ABSTRACT

The Total Guidance Information Support System (TGISS), is an information storage and retrieval system for counselors. The total TGISS, including hardware and software, extends the counselor's capabilities by providing ready access to student information under secure conditions. The hardware required includes: (1) IBM 360/50 central processing facility; (2) IBM 2314 mass storage device; (3) IBM 2260 remote video display terminal; (4) IBM 2848 display controller; (5) IBM 1053 Printer for hard copy; and (6) a modem for sending or receiving data communications to and from the central site. The TGISS software system includes: (1) IBM 05 Operating System; (2) a Type III IBM Information and Data Retrieval System called FASTER; (3) the Load; (4) an Update and File Management subsystem; and (5) the FASTER Application Programs. The program is designed to facilitate future expansion. The software functions are discussed: (1) input format and definition; (2) load and input verification program; (3) data update and revision routines and specifications; and (4) FASTER access and retrieval routines. Concluding the document is a readily understandable TGISS users' guide. The research reported herein was funded under Title III of the Elementary and Secondary Education Act. (TL)

SOFTWARE DOCUMENTATION

PART ONE

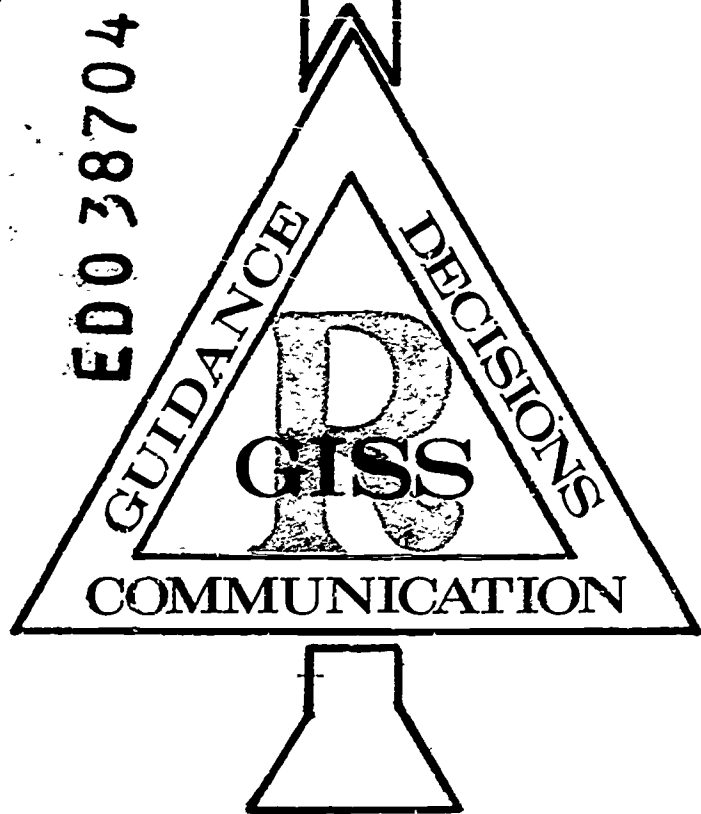

THE BARTLESVILLE SYSTEM

CE005263

DEVELOPED BY
THE BARTLESVILLE PUBLIC SCHOOLS
THE RESEARCH FOUNDATION
OKLAHOMA STATE UNIVERSITY
AND
U.S. OFFICE OF EDUCATION
E.S.E.A. Grant No. 7-8-005685-0030-(056)
OKLAHOMA STATE DEPARTMENT OF EDUCATION

TOTAL GUIDANCE
INFORMATION SUPPORT SYSTEM

U.S. DEPARTMENT OF HEALTH, EDUCATION & WELFARE
OFFICE OF EDUCATION



THIS DOCUMENT HAS BEEN REPRODUCED EXACTLY AS RECEIVED FROM THE
PERSON OR ORGANIZATION ORIGINATING IT. POINTS OF VIEW OR OPINIONS
STATED DO NOT NECESSARILY REPRESENT OFFICIAL OFFICE OF EDUCATION
POSITION OR POLICY.

THE BARTLESVILLE SYSTEM

ED038704

T G I S S

SOFTWARE DOCUMENTATION

for

The Bartlesville Public Schools

Title III, E. S. E. A. Grant No. 7-8-005685-0030-(056)

Tommy L. Roberts, Director
Wayne Richardson, Associate Director
Ed Forsberg, System Engineer
Gene Smith, Senior Analyst

January, 1970

ACKNOWLEDGMENTS

The director of project TGISS wishes to express his sincere appreciation to the Board of Education, Administrative Staff, and Counselors of the Bartlesville Public Schools for their cooperation, support, and assistance in this research and development effort. Special gratitude is extended to Earl Hamon, Superintendent, and Wayne Richardson, Assistant Superintendent, for their patience, understanding, and moral support while trying something new in an effort to improve education not only for Bartlesville but other school systems in the nation.

Special acknowledgment is due Dr. Ed Forsberg, Northwestern Oklahoma College, for his endless hours of hard work in helping design the basic system. Special thanks is given Mr. Gene Smith for his efforts in analysis and refinement of the basic system.

Other members of the task force made a number of significant contributions during the development process. These include (1) programmers Bob Jenkins, Thomas G. Roberts, Le Grande Rives, and Sherol Middleton; (2) computer center personnel at Oklahoma State University; and (3) consultants: Robert L. Gilliam, Scott P. Keahey, Barbara Rosenquist, and Drs. Rondal Gamble, Sue Hawkins, George Small, John Loughary, and Arthur Roach. Without the help of these fine professional people, the visibility of the system would not have been realized.

I would like to give special thanks to the U. S. Office of Education for providing the financial support needed in this development effort. Certainly TGISS would not have been possible without such support.

Last, but certainly not least, I would like to acknowledge my wife, Barbara, for her kind understanding and loyal support through the stresses and strains associated with a project of this magnitude. Without her encouragement at certain times when critical decisions had to be made, project progress would have been seriously inhibited.

Sincerely,

Tommy L. Roberts

TABLE OF CONTENTS

	Page
ACKNOWLEDGMENTS	ii
<i>Part One</i>	
FUNCTIONAL SPECIFICATIONS AND EXTERNAL DEFINITIONS	
I. INTRODUCTION	1
II. GENERAL DESCRIPTION	2
A. Remote Terminal	2
B. Central Site	5
C. Data Base Design	6
III. FUNCTIONAL FLOW	9
A. Input Format and Definition	9
B. Load and Input Verification Program	11
C. Data Update and Revision Routines	11
D. FASTER Access and Retrieval Routines	11
IV. SYSTEM PROCEDURES	21
A. User Command Language (UCL)	21
B. Data Base Security	22
C. CRT Displays	23
<i>Part Two</i>	
SYSTEM INTERNAL DEFINITIONS	
I. INTRODUCTION	51
II. SYSTEM DESCRIPTION	51
A. TGISS System Flow	52
B. Input Sort	53

C.	Load and Input Verification	53
D.	Data Update and Revision	54
E.	FASTER Access Routines	55
III.	FLOW CHARTS	55
A.	Load and Input Verification Program	56
B.	Data Update and Revision Program	76
C.	FASTER Access Routines	117
1.	Sign On	117
2.	Sign Off	119
3.	Student Data Record Access Routines	120

Part Three

DATA UPDATE AND REVISION
SPECIFICATIONS

I.	INTRODUCTION	123
II.	DATA BASE DESCRIPTION	123
III.	DATA ADDITION, DELETION, AND REVISION TRANSACTIONS	125
A.	Data Formats	125
B.	Data Additions	133
C.	Data Revisions	134
D.	Deletion of Records	135
E.	Special Data Conditions	135
IV.	ERROR MESSAGES AND RELATED CORRECTIONS	137
V.	TERMINAL - I D PROGRAM	139
VI.	COUNSELOR - I D PROGRAM	139

Part Four

TGISS USERS GUIDE

I.	INTRODUCTION	142
II.	TGISS SYSTEM USAGE	142
III.	SUMMARY	145
IV.	KEYWORD DICTIONARY	146

PART ONE

FUNCTIONAL SPECIFICATIONS
AND
EXTERNAL DEFINITIONS

*FUNCTIONAL SPECIFICATIONS
AND
EXTERNAL DEFINITIONS*

Total Guidance Information Support System (TGISS)

I. Introduction

Part one of this document contains the functional requirement specifications for the basic retrieval system of TGISS. Section II is a general description of the system including the remote terminals, central site, and data base design.

Section III identifies and describes the functional requirements and capabilities of the various software components. These descriptions include input formats and definitions, load and input verification programs, data update and revision routines, and FASTER Access and Retrieval Routines.

Section IV contains the external design requirements and capabilities of the user's command language. A description of provisions for data base security and the CRT displays is included in this section.

II. *General Description*

Initially, TGISS is an information storage and retrieval system specifically designed to meet the needs and requirements of the counselor in the Bartlesville Public School environment. TGISS supports the student/counselor relationship by providing pertinent information required for more effective decision making by the student and the counselor.

The environment required to support the student/counselor functions is a combination of man/machine capabilities. The total system, including the hardware and software, extends the counselor's capabilities by providing ready access to student information under secure conditions. This access is accomplished through a remote video information display terminal. The student data file is stored on the IBM 2314 mass storage device at the central processing facility (IBM 360/50). Data is retrieved by counselor interaction at the keyboard on the IBM 2260 remote video display terminal. The counselor will be provided with a user command language (UCL). This language defines and describes the information available for retrieval and display. The language is user oriented (easy to learn and use), and will allow the counselor to interact with the system in a conversational mode.

A. *Remote Terminal*

The remote video display terminal is an IBM 2260. Retrieved information is displayed on its screen on an 8 x 12 cathod-ray tube (CRT). All information is buffered and regenerated (refreshed) in the IBM 2848 control unit to provide a steady visual display.

Each display station functions independently of any other display station and has an alphanumeric keyboard for data entry, inquiry, and retrieval functions. The retrieved information displayed on the CRT is a combination of hardware/software capabilities at the central site and the remote terminal station.

The IBM 2260 video display is directly cabled to the IBM 2848 display control unit. This control unit provides a remote communication/control path between the remote display and the central processing site. The user need not be aware of this control unit.

The IBM 2848 control unit provides:

- 1) A character generator to translate input data from the communications lines to video data.
- 2) Buffer storage to store the video data for display regeneration, and store input data from keyboard entries for transmission to the processor at the central site.
- 3) Timing and logic control to synchronize interface operations, buffer storage, display station presentation, and keyboard operations.

The IBM 2848 display controller allows expansion to control a maximum of eight (8) displays of 960 characters each. Character displays are presented in twelve (12) rows of eighty (80) characters each. Display units are required to be within a distance of 2000 feet from the IBM 2848 control unit.

In addition, the remote terminal facility will have an IBM 1053 printer interface to the IBM 2848 display controller. An

adapter is required on the display controller for interface to the IBM 1053 printer. This capability provides the user a means of obtaining a printed copy of the information from the CRT display during a user session at the terminal. The printed data will be identical in content and same in format as that appearing on the display screen.

A modem is required at the remote terminal station for modulation and demodulation of data transmission. This will send and receive data to and from the central site.

To summarize the requirements at the remote terminal in terms of hardware, it will include an IBM 2260 display station, an IBM 2848 display controller, and IBM 1053 printer for hard copy, and lastly, a modem for half duplex (send or receive) data communications to and from the central site.

From the counselor point of view this is the hardware required to retrieve information from the student data base at the central processing site. In addition, the user is provided a user command language. The language is employed through the IBM 2260 keyboard and provides the counselor with an easy method to communicate with the central site and retrieve relevant student information. The language is specified later in this document under the External Design of the User Command Language (UCL).

In general, it specifies the step by step procedures required of the counselor at the remote CRT display terminal to interact with the central site for retrieval of specific data elements from the student data files. Types and kinds of displays are indicated.

B. *Central Site*

The central processing site is an IBM 360/50 computer system with the required supporting peripheral devices. This site provides TGISS with the hardware/software capability to communicate with the user at the remote terminal stations in an on-line multi-processing environment.

The TGISS software system includes IBM OS Operating System, a Type-III IBM Information and Data Retrieval System called FASTER (Filing and Source Data Entry for Easier Retrieval), the Load, Update and File Management subsystem, and the FASTER Application programs. The system is designed to facilitate future expansion. Once initial orientation for students, counselors, and administration to 2260 display terminal operation in a user atmosphere is accomplished, FASTER contains many functions which can be effectively employed in future applications.

FASTER provides the software communication link to the 2260 through the IBM 2701 communications controller. The control of lines from the remote 2260's into the central site is provided by the FASTER line control program. The data and message control is furnished by the FASTER message control program. The terminal user will utilize a small batch background partition to display requested data. The FASTER system will run in approximately a 100K partition and run concurrently with local batch jobs. The priorities, scheduling, and allocation of system resources are a function of the IBM Operating System (OS).

B. (cont'd)

The FASTER access routines will provide the TGISS system user with the capability to access user requested student information and transmit the formatted data records to the remote CRT under control of the FASTER message control program.

C. *Data Base Design*

The data base must be obtained from existing school records on each student. Information required for the data base which is not in the student record file can be collected by questionnaire. All data must eventually come from some source document whether it exists in the files or must be collected during the year from students and teachers.

The information collection process will be facilitated by utilizing a standardized data form. This form is being generated as part of the data base design effort. The form serves as the means of transcribing information from the original source document to the computer input stream.

The next step in the process is to prepare the data so it is machine readable. In the case of TGISS this includes keypunching/verification of the source material on all students from the data form. The result of keypunch and verification is that the data is now on cards for input to the computer input stream for creation of the student data file. The data contained in the student record is generally classified as follows:

1. General Data
2. Health Record

C. (cont'd)

3. Work Experience
4. Standard Test Scores
5. Transcript I
6. Transcript II
7. Grade Point Averages (GPA)
8. Absences
9. Interests/Preferences/Honors
10. Health Profile
11. Current Schedule

Each of these will be discussed to identify those items within each classification.

1. *General Data* consists of the student's I.D. number, name, sex, race, home address, home telephone number, birth date, father's employer, father's business phone, mother's employer, mother's business phone, family doctor and telephone, current grade level, religion and high school track.
2. The *Health Record* data grouping consists of storage for several diseases. Information relating to the disease will be carried as part of this data grouping and should be supplied by a qualified nurse.
3. The *Work Experience* data grouping consists of data for several jobs. Present plans allow adequate storage for each job so that the information for each job can vary in its format and content.
4. The *Standardized Test Scores* data grouping consists of a composite score of three (3) tests: Kuhlman, SRA and DAT.

C. (cont'd)

5. *Transcript I* consists of course information for grades 7 and 8. Each course descriptor consists of the course name, and the course marks made during each school year.
6. *Transcript II* contains descriptors pertaining to courses taken during grades 9, 10, 11, and 12. The information in the data base for each course consists of a credit code, a course number, a course name, and a grade for semester 1 and semester 2. The credits code is the number of half credits.
7. The *GPA* grouping will be computed in the update and revision program from student grades as they are added to the student data record. Student grades will be input for Junior High by year and then in 9 week intervals in High School in addition to semester grade input.
8. The *Absence* grouping consists of total current absences and the absences in half days for each of the 36 weeks of a semester.
9. The *Interests/Preferences/Honors* data group provides for several lines of CRT display. Information to be inserted does not have a specified format at this time. Storage will be allocated and reserved for each line.
10. The *Health Profile* contains a descriptor for each of the following physical characteristics: eyes, ears, teeth, heart, feet, growth, and respiration. The descriptor represents a point on a 3 point scale from +1 to +3.
11. The *Current Schedule* data consists of information pertinent to the courses that the student is currently enrolled in. This

C. (cont'd)

includes the period number, the course name, the location, and the teacher.

The above items concern themselves with the specifications and requirements of the data items stored in the Student Data File. Data is so organized in the file that it easily lends itself to CKF display requirements.

After the information has been collected and prepared for input to the central processor, the next step is to consider the requirements to store this data in an organized manner on the mass storage device (the IBM 2314 Random Access Storage Facility).

III. *FUNCTIONAL FLOW*

The major components of the software development and their interfaces are identified as follows:

- A. Input Format and Definition
- B. Load and Input Verification Program
- C. Data Update and Revision Program
- D. FASTER Access and Retrieval Routines

All line control, message control and terminal polling will be handled by FASTER. Detailed documentation of these functions is included in the IBM documentation on FASTER. Filing and Source Data Entry Techniques for Easier Retrieval - 360D-06. 7.011.

A. *Input Format and Definition*

The input will be keypunched from transcription sheets used to collect the data for the TGISS student data files. The data will be keypunched in the formats displayed in Figure 1. Card codes

A. (cont'd)

which are represented by X4, X5, etc., are cases in which multiple cards are required to input the related data. The fixed portion of each card is student-ID-number (columns 1-6), type-of-action code (column 78), and card-code (columns 79-80). Columns 7 through 77 will contain student record data to be input to the TGISS system.

The input cards required for initial as well as subsequent students to be added to the TGISS student data file will be cards 01, 02, 03, X4, X5, 06, X7, X8, 09, XA, and 0B. When multiple cards are input for X designated card types, they will be sequentially numbered by punching in the first position of the card code (X) beginning with a numeric zero (0) and continuing through nine (9). Each group of cards input to add a student's data to the TGISS file must have a master card (01) as the first card in the group.

The input cards which add absences, revise student schedules, and add 9-week student grades are represented in Figure 1 by card codes 0C, XD, and 0E, respectively.

The type-of-action code (TOA) must be included in cards 01 (master card), 0C, 0D, and 0E. Column 78 in the other card types must be blank. Data can be added or revised in the student record by using an 01 card with student-ID-number, student name, and TOA code followed by appropriate card types and their included data fields. The TOA code for adding data will be an (A), and (R) for revising data. A student's data may be completely deleted from the TGISS data file by using a master card (01) and a TOA code of D. When card types 0C, 0D, and 0E are input the TOA must be blank.

B. *Load and Input Verification* includes the following functions:

1. Read cards onto disk.
2. Sorts input data on student-ID-number and card code.
3. Validates student ID number and student name.
4. Assembles and combines input data cards to form student information record.

The combined data cards are then written onto disk in a student data record which is input to the update and revision program.

C. The *Update and Revision* program includes the following functions:

1. Creation of the initial indexed sequential data base.
2. Addition of student data records when appropriate.
3. Revision of data fields in student data records.
4. Addition of data fields not input at origination of TGISS data base.
5. Updating student data records, when appropriate, as the student progresses in his field of study.
6. Computation of grade point averages in periods of 9 weeks, semesters, grade levels, and overall grade point average.
7. Deletion of student records in the TGISS file.

The student data records will be stored and accessed using indexed sequential access method (ISAM) with the function to be performed on the student data record being determined by a type-of-action code (TOA) designated by the user or the person charged with generating input to the system.

D. *FASTER Access and Retrieval Routines*

The FASTER system will control:

D. (cont'd)

1. Network Polling
2. Line Control
3. Message Control
4. I/O Buffering
5. System and/or Terminal Abends

The FASTER access and retrieval routines will:

1. Interpret User Commands
2. Maintain History Files
3. Access Requested Data
4. Display Data in Assigned Formats

The command which is issued by the counselor from the terminal must be interpreted and equated to a stored FASTER routine. The FASTER routine is called to access and display the information necessary to satisfy the user request. History files of pertinent information will be kept concerning terminal usage, user identification, and routine utilization. In the event that illegal commands are issued from the terminal, error messages will be displayed at the terminal notifying the user of the error and requesting re-input of the command.

It will be necessary for the terminal user to sign on before attempting to request student record data. Once the user has signed on he is free to retrieve through the FASTER routines any data he wishes from a student data record.

FIGURE 1 - (cont'd on following pages)



MASTER CARD - 01

ID	STUDENT NAME	GRADE	SEX	EGL	RESIDENT	AGE	DATE OF BIRTH	STUDENT ADDRESS			TRANSFERRED	SCHOOL SITE	HOME DISTRICT	TEACHER NO.	CARD CODE																																																																
								NO.	DIR	STREET																																																																					
1	2	3	4	5	6	7	8	9	10	11	12	13	14	15	16	17	18	19	20	21	22	23	24	25	26	27	28	29	30	31	32	33	34	35	36	37	38	39	40	41	42	43	44	45	46	47	48	49	50	51	52	53	54	55	56	57	58	59	60	61	62	63	64	65	66	67	68	69	70	71	72	73	74	75	76	77	78	79	80

GENERAL CARD - 02

ID	PHONE NO.	FATHER'S EMPLOYER	FATHER'S BUSINESS PHONE		MOTHER'S EMPLOYER	MOTHER'S BUSINESS PHONE		CARD CODE																																																																							
			NO.	EXT.		NO.	EXT.																																																																								
1	2	3	4	5	6	7	8	9	10	11	12	13	14	15	16	17	18	19	20	21	22	23	24	25	26	27	28	29	30	31	32	33	34	35	36	37	38	39	40	41	42	43	44	45	46	47	48	49	50	51	52	53	54	55	56	57	58	59	60	61	62	63	64	65	66	67	68	69	70	71	72	73	74	75	76	77	78	79	80





GENERAL CARD CONT'D - 03

ID	FAMILY DOCTOR LAST NAME	DOCTOR PHONE	CURRENT GRADE	CHURCH	H.S. TRACK	SCHOOL TRANSFERRED FROM	CORE		CARD CODE
							YR GRAD	YR GRAD	
77777	7777777777777777	777777	77777777	7777777777777777	7777777777777777	7777777777777777	7777	7777777777777777	7777777777777777
68888	8888888888888888	88888888	88888888	8888888888888888	8888888888888888	8888888888888888	8888	8888888888888888	8888888888888888
99999	9999999999999999	99999999	99999999	9999999999999999	9999999999999999	9999999999999999	9999	9999999999999999	9999999999999999
1 2 3 4 5 6 7 8 9 10 11 12 13 14 15 16 17 18 19 20 21 22 23 24 25 26 27 28 29 30 31 32 33 34 35 36 37 38 39 40 41 42 43 44 45 46 47 48 49 50 51 52 53 54 55 56 57 58 59 60 61 62 63 64 65 66 67 68 69 70 71 72 73 74 75 76 77 78 79 80	IBM [500]								

HEALTH RECORD CARD - X4

ID	NAME OF DISEASE	DT OF DS		DT OF VA		NAME OF DISEASE	DT OF DS		DT OF VA		NAME OF DISEASE	CARD CODE
		DT	OF	DT	OF		DT	OF	DT	OF		
77777	7777777777777777	7777	7777	7777777777777777	7777	7777777777777777	7777	7777	7777777777777777	7777	7777777777777777	7777
88888	8888888888888888	8888	8888	8888888888888888	8888	8888888888888888	8888	8888	8888888888888888	8888	8888888888888888	8888
99999	9999999999999999	9999	9999	9999999999999999	9999	9999999999999999	9999	9999	9999999999999999	9999	9999999999999999	9999
1 2 3 4 5 6 7 8 9 10 11 12 13 14 15 16 17 18 19 20 21 22 23 24 25 26 27 28 29 30 31 32 33 34 35 36 37 38 39 40 41 42 43 44 45 46 47 48 49 50 51 52 53 54 55 56 57 58 59 60 61 62 63 64 65 66 67 68 69 70 71 72 73 74 75 76 77 78 79 80	IBM [500]											



WORK EXPERIENCE CARD - X5

ID	JOB EXPERIENCE	JOB EXPERIENCE	JOB EXPERIENCE	CARD CODE
	JOB NAME	JOB NAME	JOB NAME	
	<small>YDL CODE</small>	<small>YDL CODE</small>	<small>YDL CODE</small>	
	<small>MOS. EXP.</small>	<small>MOS. EXP.</small>	<small>MOS. EXP.</small>	
	777777	777777	777777	777777
	688888	688888	688888	688888
	999999	999999	999999	999999
	<small>1 2 3 4 5 6 7 8 9 10 11 12 13 14 15 16 17 18 19 20 21 22 23 24 25 26 27 28 29 30 31 32 33 34 35 36 37 38 39 40 41 42 43 44 45 46 47 48 49 50 51 52 53 54 55 56 57 58 59 60 61 62 63 64 65 66 67 68 69 70 71 72 73 74 75 76 77 78 79 80</small>			

STANDARD TESTS CARD - 06

ID	SRA	DAT	CARD CODE
	PART	PART	
<small>KUHLMAN</small>		<small>COMP</small>	
	<small>1 2 3 4 5 6 7 8 9 10 11 12 13</small>	<small>1 2 3 4 5 6 7 8 9</small>	
	777777	777777	777777
	688888	688888	688888
	999999	999999	999999
	<small>1 2 3 4 5 6 7 8 9 10 11 12 13 14 15 16 17 18 19 20 21 22 23 24 25 26 27 28 29 30 31 32 33 34 35 36 37 38 39 40 41 42 43 44 45 46 47 48 49 50 51 52 53 54 55 56 57 58 59 60 61 62 63 64 65 66 67 68 69 70 71 72 73 74 75 76 77 78 79 80</small>		



TRANSCRIPT FOR 7TH & 8TH GRADES - X7

ID	COURSE			COURSE			COURSE			COURSE			CARD CODE																																																																			
	NO.	NAME	GRD.	NO.	NAME	GRD.	NO.	NAME	GRD.	NO.	NAME	GRD.																																																																				
	1	2	3	4	5	6	7	8	9	10	11	12	13	14	15	16	17	18	19	20	21	22	23	24	25	26	27	28	29	30	31	32	33	34	35	36	37	38	39	40	41	42	43	44	45	46	47	48	49	50	51	52	53	54	55	56	57	58	59	60	61	62	63	64	65	66	67	68	69	70	71	72	73	74	75	76	77	78	79	80

TRANSCRIPT FOR 9TH, 10TH, 11TH and 12TH GRADES - X8

ID	COURSE				COURSE				COURSE				CARD CODE																																																																			
	NO.	NAME	GRADE LEVEL	GRADE CREDITS	NO.	NAME	GRADE LEVEL	GRADE CREDITS	NO.	NAME	GRADE LEVEL	GRADE CREDITS																																																																				
	1	2	3	4	5	6	7	8	9	10	11	12	13	14	15	16	17	18	19	20	21	22	23	24	25	26	27	28	29	30	31	32	33	34	35	36	37	38	39	40	41	42	43	44	45	46	47	48	49	50	51	52	53	54	55	56	57	58	59	60	61	62	63	64	65	66	67	68	69	70	71	72	73	74	75	76	77	78	79	80



HEALTH PROFILE CARD - OB

ID	HEALTH PROFILE	CARD CODE
1	AGE	
2	SEX	
3	RACE	
4	ETHNICITY	
5	RELIGION	
6	EDUCATION	
7	HEIGHT	
8	WEIGHT	
9	BLOOD PRESSURE	
10	HEART RATE	
11	CHOLESTEROL	
12	GLUCOSE	
13	DIABETES	
14	ASTHMA	
15	ALLERGIES	
16	SMOKING	
17	ALCOHOL	
18	DRUGS	
19	STRESS	
20	SLEEP	
21	DIET	
22	EXERCISE	
23	GENERAL HEALTH	
24	MENTAL HEALTH	
25	PHYSICAL HEALTH	
26	FUNCTIONAL STATUS	
27	QUALITY OF LIFE	
28	DISABILITY	
29	HEALTH CARE USE	
30	HEALTH CARE SATISFACTION	
31	HEALTH CARE ACCESS	
32	HEALTH CARE COSTS	
33	HEALTH CARE QUALITY	
34	HEALTH CARE SAFETY	
35	HEALTH CARE EQUITY	
36	HEALTH CARE EFFICIENCY	
37	HEALTH CARE EFFECTIVENESS	
38	HEALTH CARE ACCESSIBILITY	
39	HEALTH CARE AFFORDABILITY	
40	HEALTH CARE AVAILABILITY	
41	HEALTH CARE ACCEPTABILITY	
42	HEALTH CARE ADAPTABILITY	
43	HEALTH CARE ACCURACY	
44	HEALTH CARE APPROPRIATENESS	
45	HEALTH CARE AUTHORITY	
46	HEALTH CARE CREDIBILITY	
47	HEALTH CARE COMPETENCE	
48	HEALTH CARE CONFIDENCE	
49	HEALTH CARE COURTESY	
50	HEALTH CARE COURTESY	
51	HEALTH CARE COURTESY	
52	HEALTH CARE COURTESY	
53	HEALTH CARE COURTESY	
54	HEALTH CARE COURTESY	
55	HEALTH CARE COURTESY	
56	HEALTH CARE COURTESY	
57	HEALTH CARE COURTESY	
58	HEALTH CARE COURTESY	
59	HEALTH CARE COURTESY	
60	HEALTH CARE COURTESY	
61	HEALTH CARE COURTESY	
62	HEALTH CARE COURTESY	
63	HEALTH CARE COURTESY	
64	HEALTH CARE COURTESY	
65	HEALTH CARE COURTESY	
66	HEALTH CARE COURTESY	
67	HEALTH CARE COURTESY	
68	HEALTH CARE COURTESY	
69	HEALTH CARE COURTESY	
70	HEALTH CARE COURTESY	
71	HEALTH CARE COURTESY	
72	HEALTH CARE COURTESY	
73	HEALTH CARE COURTESY	
74	HEALTH CARE COURTESY	
75	HEALTH CARE COURTESY	
76	HEALTH CARE COURTESY	
77	HEALTH CARE COURTESY	
78	HEALTH CARE COURTESY	
79	HEALTH CARE COURTESY	
80	HEALTH CARE COURTESY	
81	HEALTH CARE COURTESY	
82	HEALTH CARE COURTESY	
83	HEALTH CARE COURTESY	
84	HEALTH CARE COURTESY	
85	HEALTH CARE COURTESY	
86	HEALTH CARE COURTESY	
87	HEALTH CARE COURTESY	
88	HEALTH CARE COURTESY	
89	HEALTH CARE COURTESY	
90	HEALTH CARE COURTESY	
91	HEALTH CARE COURTESY	
92	HEALTH CARE COURTESY	
93	HEALTH CARE COURTESY	
94	HEALTH CARE COURTESY	
95	HEALTH CARE COURTESY	
96	HEALTH CARE COURTESY	
97	HEALTH CARE COURTESY	
98	HEALTH CARE COURTESY	
99	HEALTH CARE COURTESY	
100	HEALTH CARE COURTESY	

WEEKLY ABSENCE INPUT CARD - OC

ID	STUDENT NAME	SCHOOL WEEK NO	ABSENT NO	CARD CODE
1				
2				
3				
4				
5				
6				
7				
8				
9				
10				
11				
12				
13				
14				
15				
16				
17				
18				
19				
20				
21				
22				
23				
24				
25				
26				
27				
28				
29				
30				
31				
32				
33				
34				
35				
36				
37				
38				
39				
40				
41				
42				
43				
44				
45				
46				
47				
48				
49				
50				
51				
52				
53				
54				
55				
56				
57				
58				
59				
60				
61				
62				
63				
64				
65				
66				
67				
68				
69				
70				
71				
72				
73				
74				
75				
76				
77				
78				
79				
80				



CURRENT SCHEDULE CARD - XD

ID	COURSE NAME	LOCATION	PERIOD		COURSE NAME	LOCATION	PERIOD		TEACHER'S NAME	CARD CODE
11111111	111111111111	111111111111	111111111111	111111111111	111111111111	111111111111	111111111111	111111111111	1111	
66666666	666666666666	666666666666	666666666666	666666666666	666666666666	666666666666	666666666666	666666666666	6666	
99999999	999999999999	999999999999	999999999999	999999999999	999999999999	999999999999	999999999999	999999999999	9999	
1 2 3 4 5 6 7 8 9 10 11 12 13 14 15 16 17 18 19 20 21 22 23 24 25 26 27 28 29 30 31 32 33 34 35 36 37 38 39 40 41 42 43 44 45 46 47 48 49 50 51 52 53 54 55 56 57 58 59 60 61 62 63 64 65 66 67 68 69 70 71 72 73 74 75 76 77 78 79 80										

NINE WEEK (9 WK) GPA CARD - 0E

ID	9 WEEK PERIOD NO.		COURSE NO.		COURSE NO.		COURSE NO.		COURSE NO.		COURSE NO.		COURSE NO.		CARD CODE
11111111	11111111	11111111	11111111	11111111	11111111	11111111	11111111	11111111	11111111	11111111	11111111	11111111	11111111	1111	
66666666	66666666	66666666	66666666	66666666	66666666	66666666	66666666	66666666	66666666	66666666	66666666	66666666	66666666	6666	
99999999	99999999	99999999	99999999	99999999	99999999	99999999	99999999	99999999	99999999	99999999	99999999	99999999	99999999	9999	
1 2 3 4 5 6 7 8 9 10 11 12 13 14 15 16 17 18 19 20 21 22 23 24 25 26 27 28 29 30 31 32 33 34 35 36 37 38 39 40 41 42 43 44 45 46 47 48 49 50 51 52 53 54 55 56 57 58 59 60 61 62 63 64 65 66 67 68 69 70 71 72 73 74 75 76 77 78 79 80															

FIGURE 2 - TGISS SYSTEM FLOW

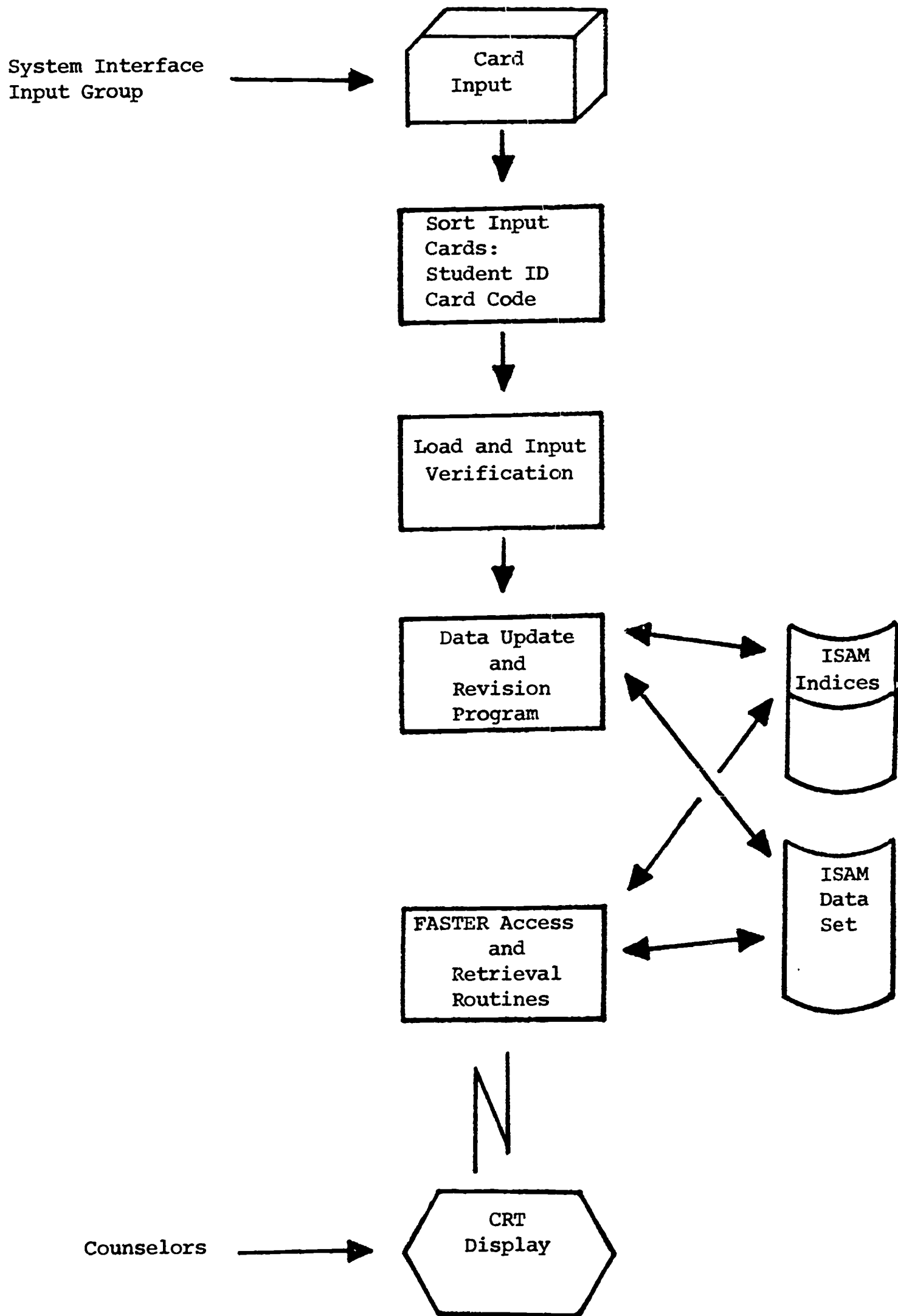

IV. *System Procedures*

A. *User Command Language*

The user of TGISS is supplied with a set of commands that will allow him to access information in the student data base. This command language will be divided into types by function. In order to gain access to the TGISS system through a terminal, a user must sign-on and supply his social security number as a security code. The security code procedure (supplied by FASTER) will prevent unauthorized use of the TGISS system and its data base. After sign-on has been completed the user will be ready to access specific student data using the user command language.

The second type of command will allow the user (counselors) to access, query, and retrieve data from the student data base. Phase II implementation will allow on-line update of data records using FASTER routines. The following list constitutes Phase I commands and will retrieve data pertinent to the following areas.

<i>Command</i>	<i>Retrieved Data</i>
1. OGPA	Overall Grade Point Average
2. HLTP	Student Health Profile
3. TR78	Student Transcript-Junior High
4. TRAN	Student Transcript-High School
5. GPAS	Grade Point Averages
6. WRKX	Work Experience
7. CURS	Current Schedule
8. GRDT	Grade Trends
9. SDTS	Standard Test Scores

A. (cont'd)

<i>Command</i>	<i>Retrieved Data</i>
10. IPHS	Interests/Preferences/Honors
11. GNRL	General Data
12. HLRD	Health Record
13. SGON	Terminal Sign-on
14. SGOF	Terminal Sign-off

In using each of the commands, except sign-on and sign-off, the user enters the command, a slash, and the student-ID-number of the student on which data is required. The user then depresses the shift and enter keys on the 2260 keyboard and the message is transmitted to the computer.

Invalid commands or student-ID-numbers will return no data and a corresponding error message will be transmitted to the sending terminal.

B. *Data Base Security*

Protection of data from unauthorized use and access is of concern whenever files of information are maintained concurrent with any centralization of data and implementation of terminal-based systems. However, any security mechanism employed is relative to how the mechanism and its operation are secured.

Security provided in the TGISS system is inherent in the FASTER system and is divided into two parts:

1. Protection built into the system itself.
2. That protection which can be added by the programmer through the use of the Macro language and functional capabilities of FASTER.

Three elements provided under the first part (1.) are:

- a. A user-defined transaction code must be the first data entered at a terminal.
- b. The terminal must have been enabled by the programmer to accept the transaction code entered.
- c. The user-defined data format must be correctly entered from the terminal following the transaction code.

An additional capability is the ability of the data processing center to logically disconnect any terminal of the system during periods of unauthorized access.

The second part (2.) of FASTER security allows the programmer to insert an authorized path by which an operator's authorization can be tested. The operator will be required to enter a code at sign-on time to gain access to privileged data. These codes and methods of access will be explained in the TGISS users guide published when the terminals are properly brought on-line and are operating.

c. *CRT Displays*

The following figures will illustrate the terminal displays of student data requested by the user through his user command language.



FIGURE 3

1. Counselor Inquiry - Sign On

A diagram of a sign-on form. It consists of a large outer rectangle with rounded corners. Inside this is a smaller, rounded rectangle representing the sign-on area. The text "SGON/social security number in nine consecutive digits" is written vertically along the left side of this inner rectangle. The form is intended for a counselor inquiry.



FIGURE 3 (cont'd)

TGISS System Response

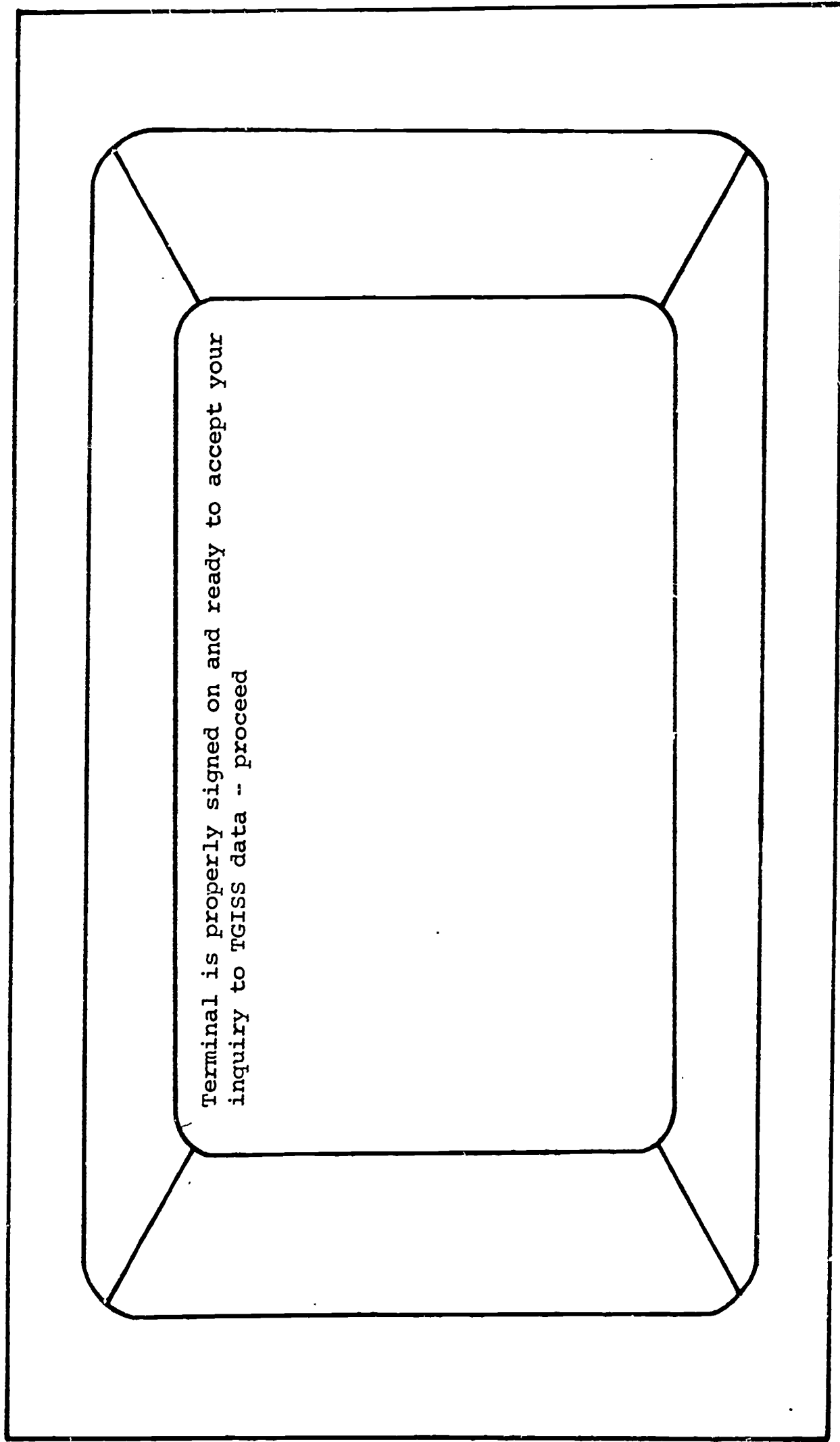

FIGURE 4

1. Counselor Inquiry - Overall Grade Point Average

OGPA/student number



FIGURE 4 (cont'd)
TGISS System Response

YEAR	OVERALL GPA	Student Name	Student Number
7	OVERALL GPA		
8			
9			
10			
11			
12			



FIGURE 5

1. Counselor Inquiry - Student Health Profile

HLTP/student number





FIGURE 5 (cont'd)

TGISS System Response

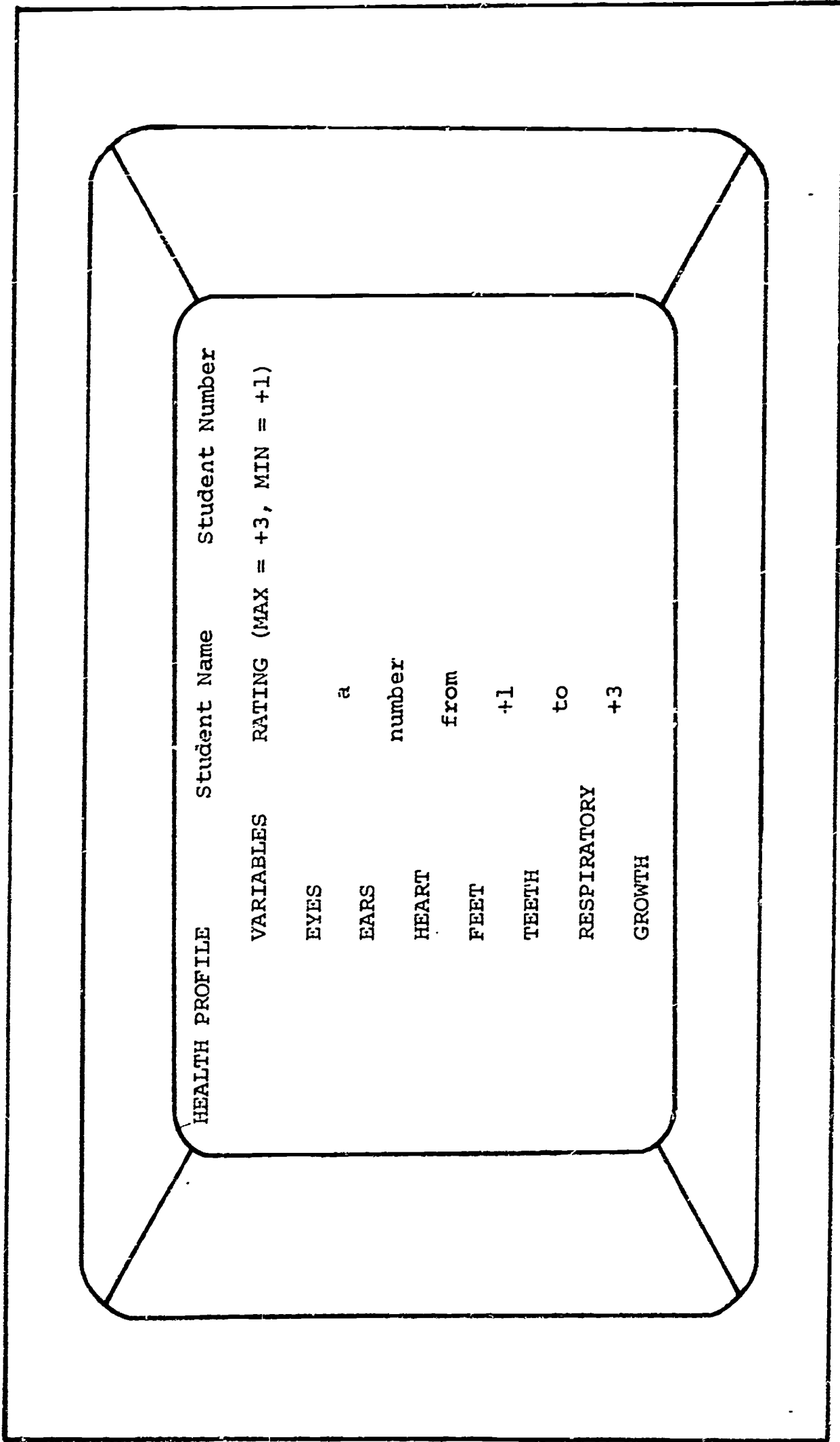



FIGURE 6

1. Counselor Inquiry - Student Transcript for Grades 9, 10, 11, and 12

A diagram showing the layout of a student transcript form. It consists of a large outer rectangle with rounded corners. Inside this is a smaller, horizontally-oriented rounded rectangle. The text "TRAN/student number" is printed vertically along the left side of this inner rectangle. The rest of the form is blank, indicating where student information would be entered.



FIGURE 6 (cont'd)

TGISS System Response

HIGH SCHOOL TRANSCRIPT	Student Name	Student Number
COURSE NAME	GRADE 1	GRADE 2 1/2 CREDITS

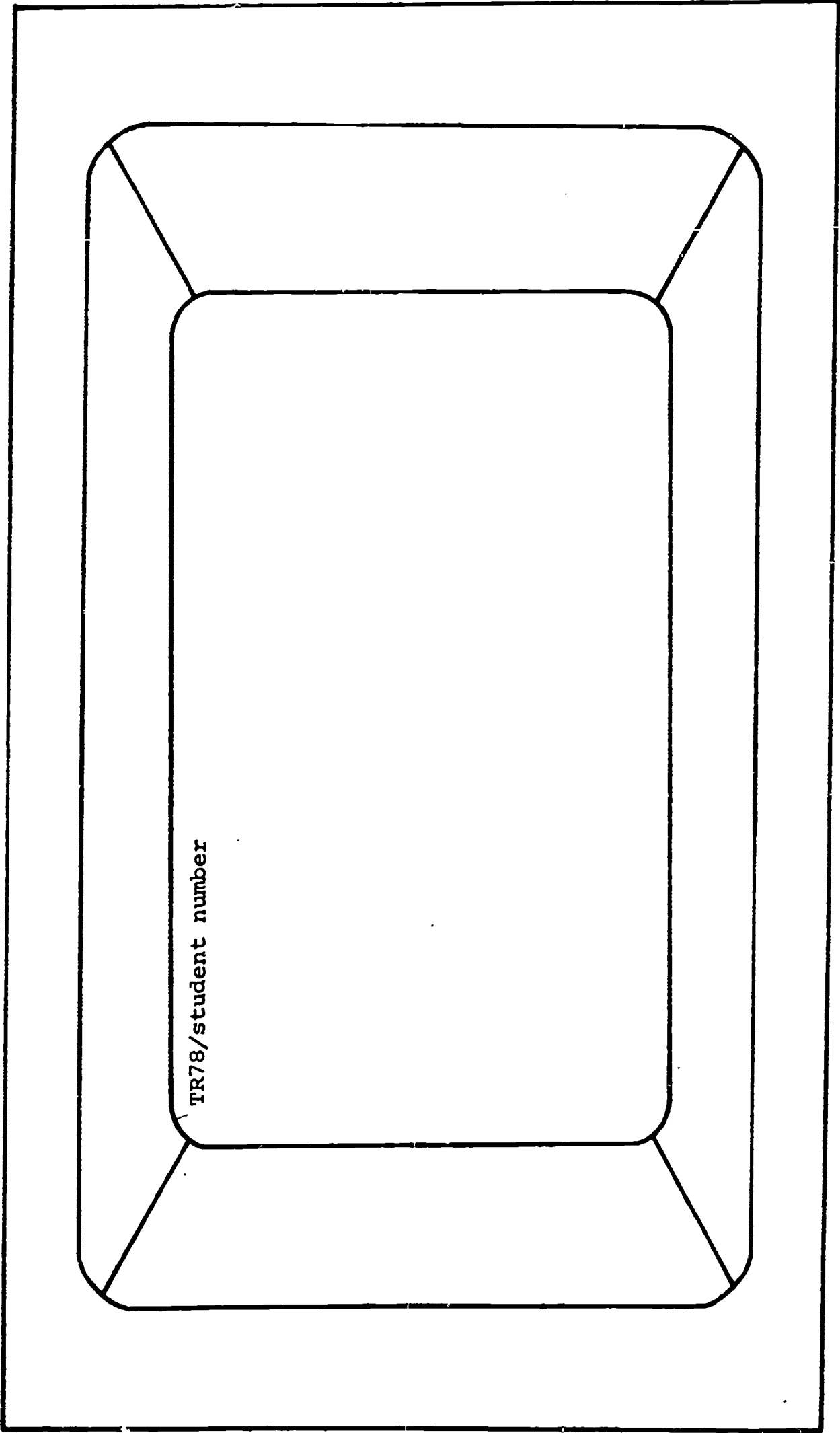

FIGURE 7

i. Counselor Inquiry - Year 7 and 8 Transcript





FIGURE 7 (cont'd)

TGISS System Response

YEAR 7 & 8 TRANSCRIPT	Student Name	Student Number
COURSE NAME	COURSE NUMBER	GRADE 1
		GRADE 2

FIGURE 8

1. Counselor Inquiry - Grade Point Averages

GPAS/student number





FIGURE 8 (cont'd)

TGISS System Response

GRADE POINT AVERAGES	Student Name	Student Number
OVERALL GPA = X.XXX		
AREA GPA = X.XXX		
NINE WEEK GPA = X.XXX		
AREA IS area name		

FIGURE 9

1. Counselor Inquiry - Work Experience

WRKX/student number



FIGURE 9 (cont'd)

TGISS System Response

WORK EXPERIENCE	Student Name	Student Number
JOB TITLE	VOLUNTEER OR NON-VOL	



FIGURE 10

1. Counselor Inquiry - Current Schedule

A large rectangular frame containing a smaller rounded rectangle. Inside the rounded rectangle, the text "CURS/student number" is written vertically.





FIGURE 10 (cont'd)

TGISS System Response

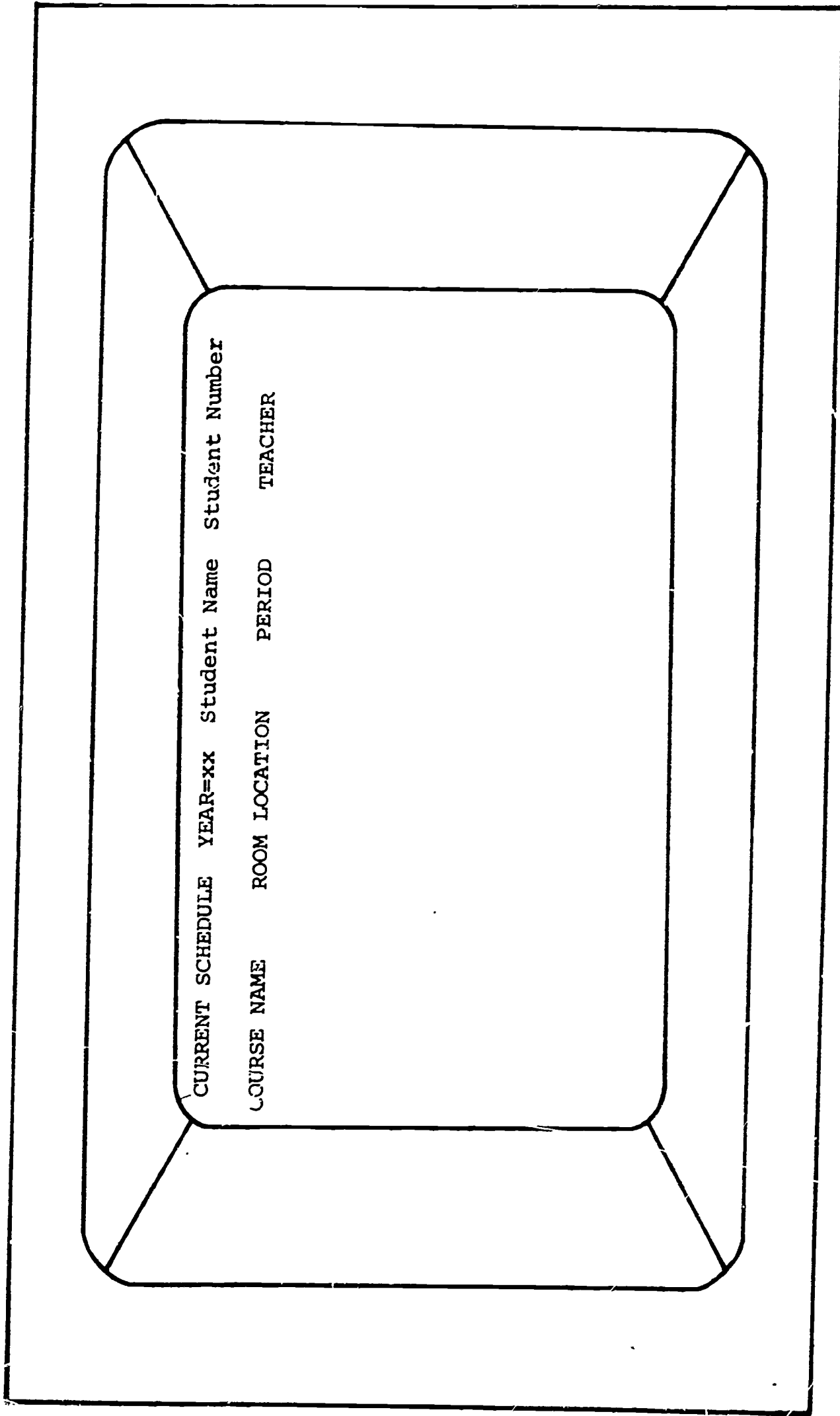

FIGURE 11

1. Counselor Inquiry - Grade Trends

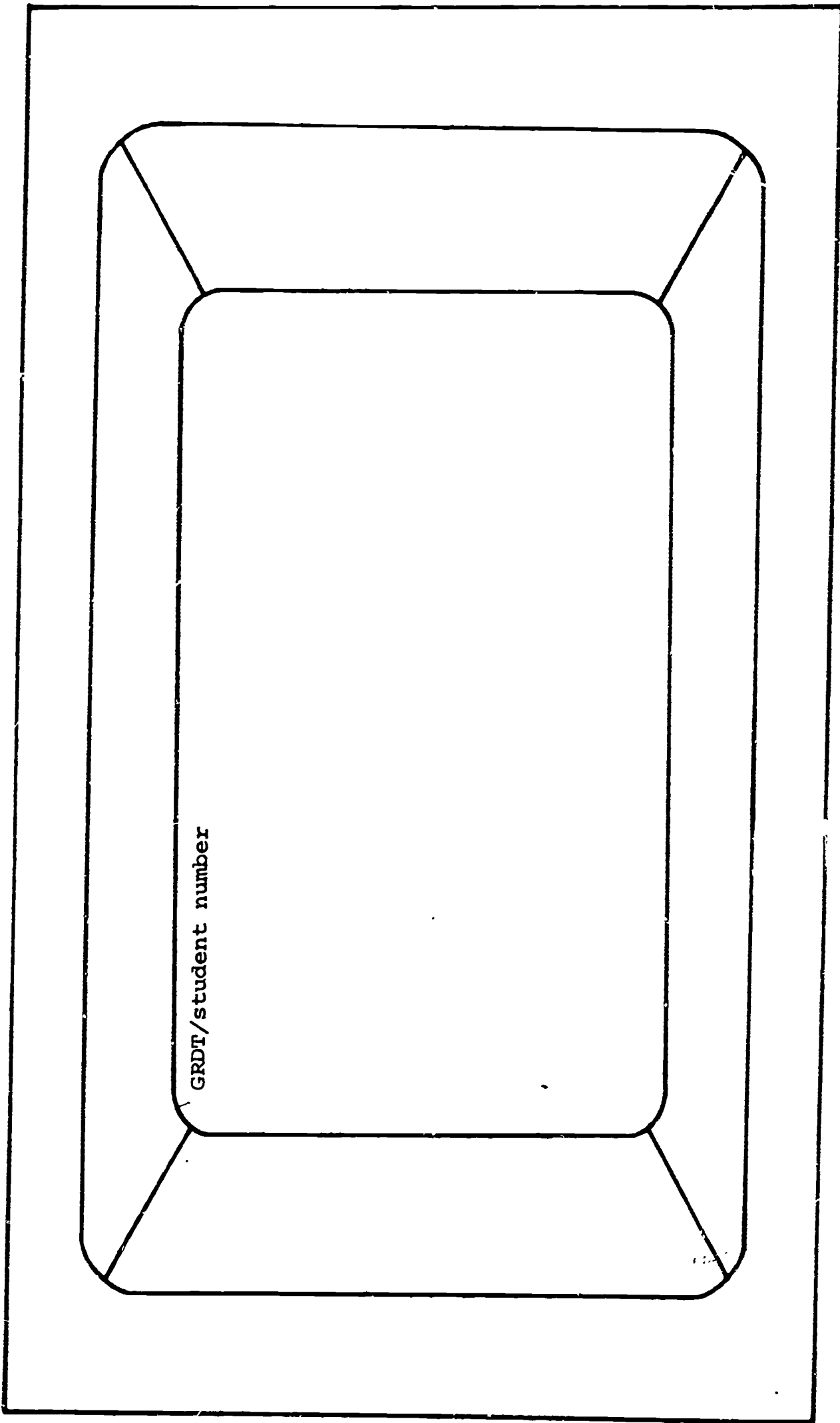



FIGURE 11 (cont'd)

TGISS System Response

GRADE TRENDS		Student Name	Student Number
<u>YEAR</u>	<u>GPA</u>		
7	2.1		
8	3.1		
9			
10			
11			
12			



FIGURE 12

1. Counselor Inquiry - Standard Test Scores

A large rectangular box with rounded corners is centered on the page. Inside this box is a smaller rounded rectangle. The text "SDTS/student. number" is written vertically inside the smaller rectangle. A handwritten mark, possibly a stylized letter 'A', is visible on the left side of the larger box.



FIGURE 12 (cont'd)

TGISS System Response

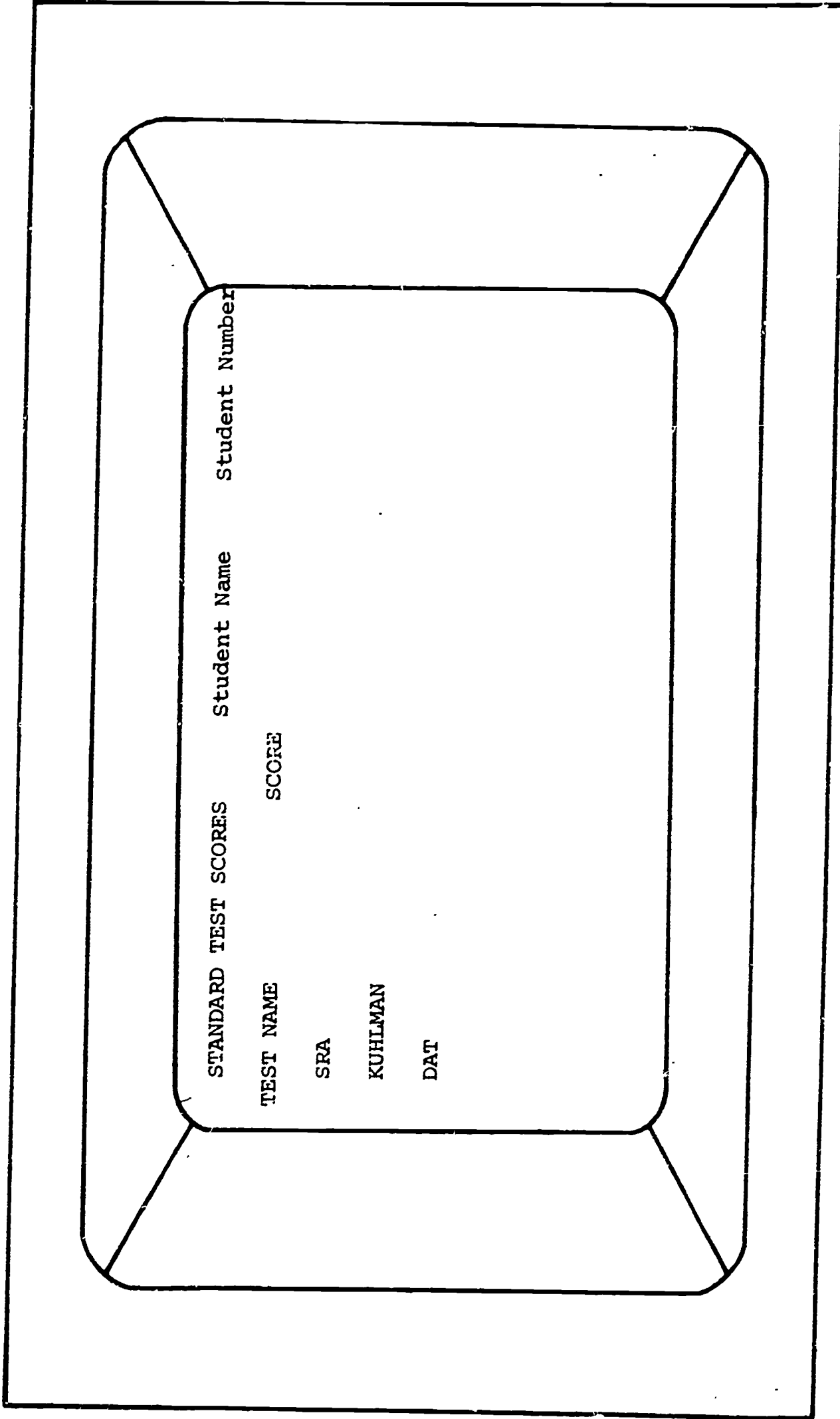
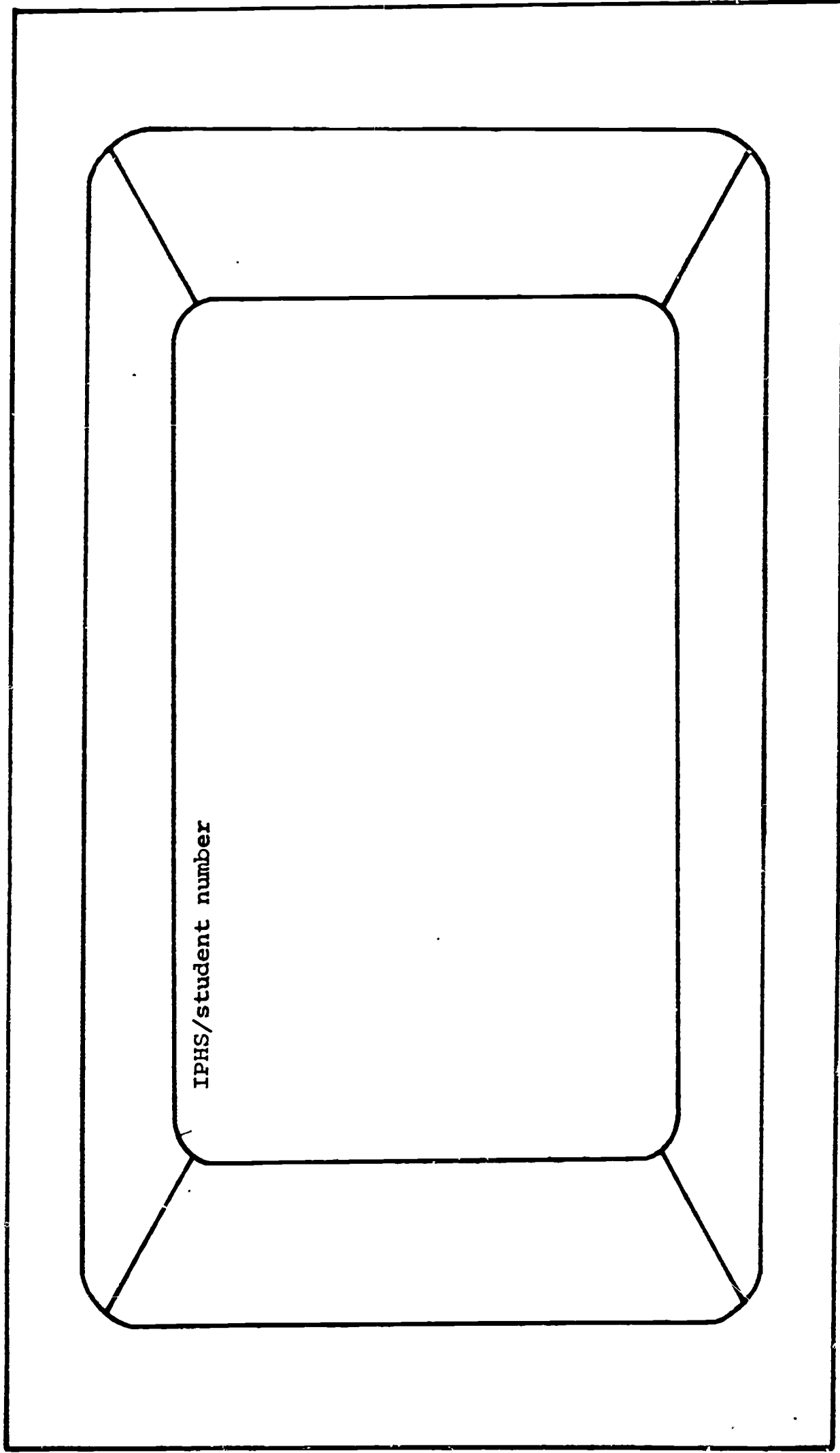

FIGURE 13

1. Counselor Inquiry - Interests/Preferences/Honors



IPHS/student number



FIGURE 13 (cont'd)

TGISS System Response

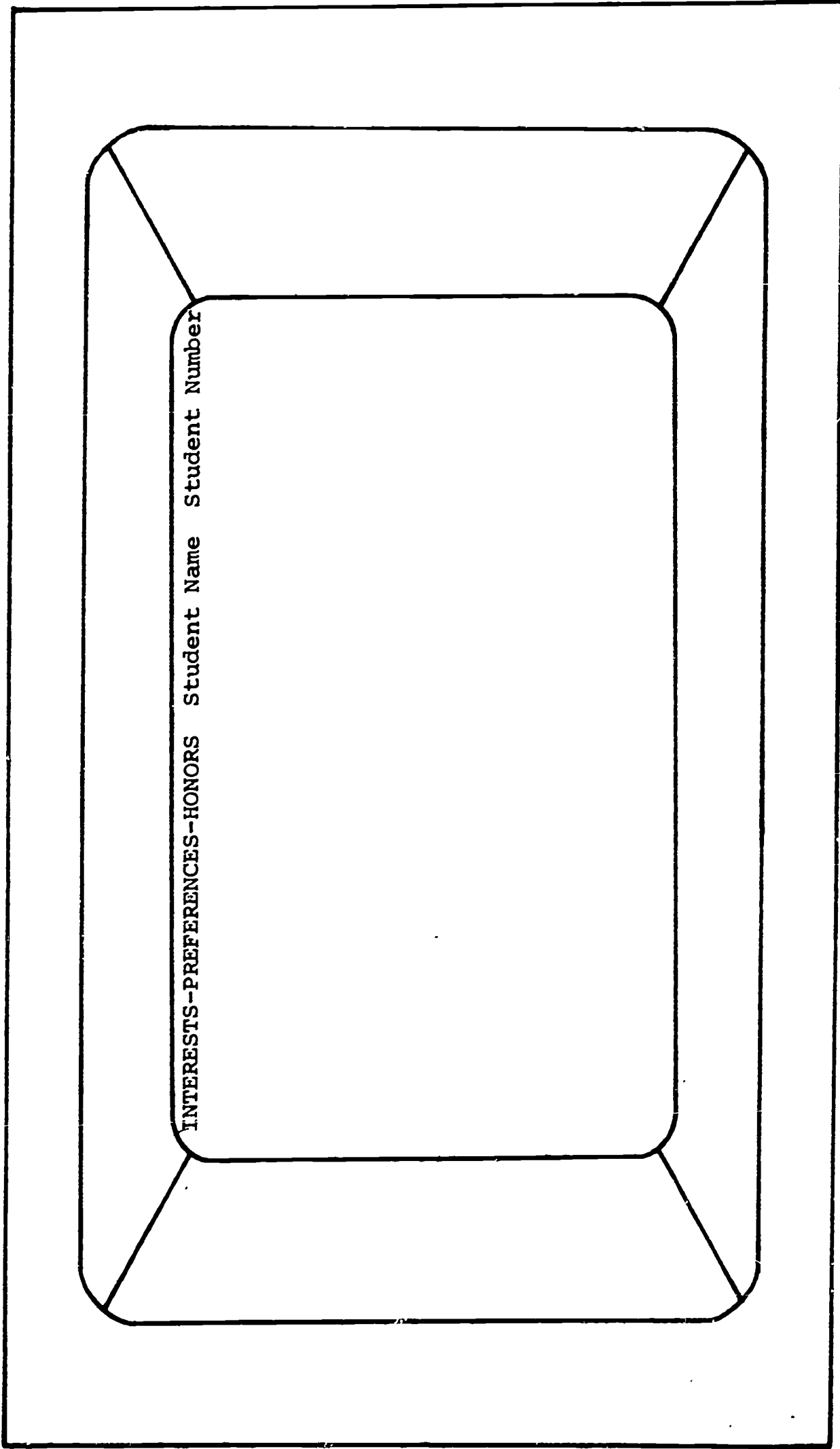



FIGURE 14

1. Counselor Inquiry - General Information

GNRL/student number



FIGURE 14 (cont'd)

TGISS System Response

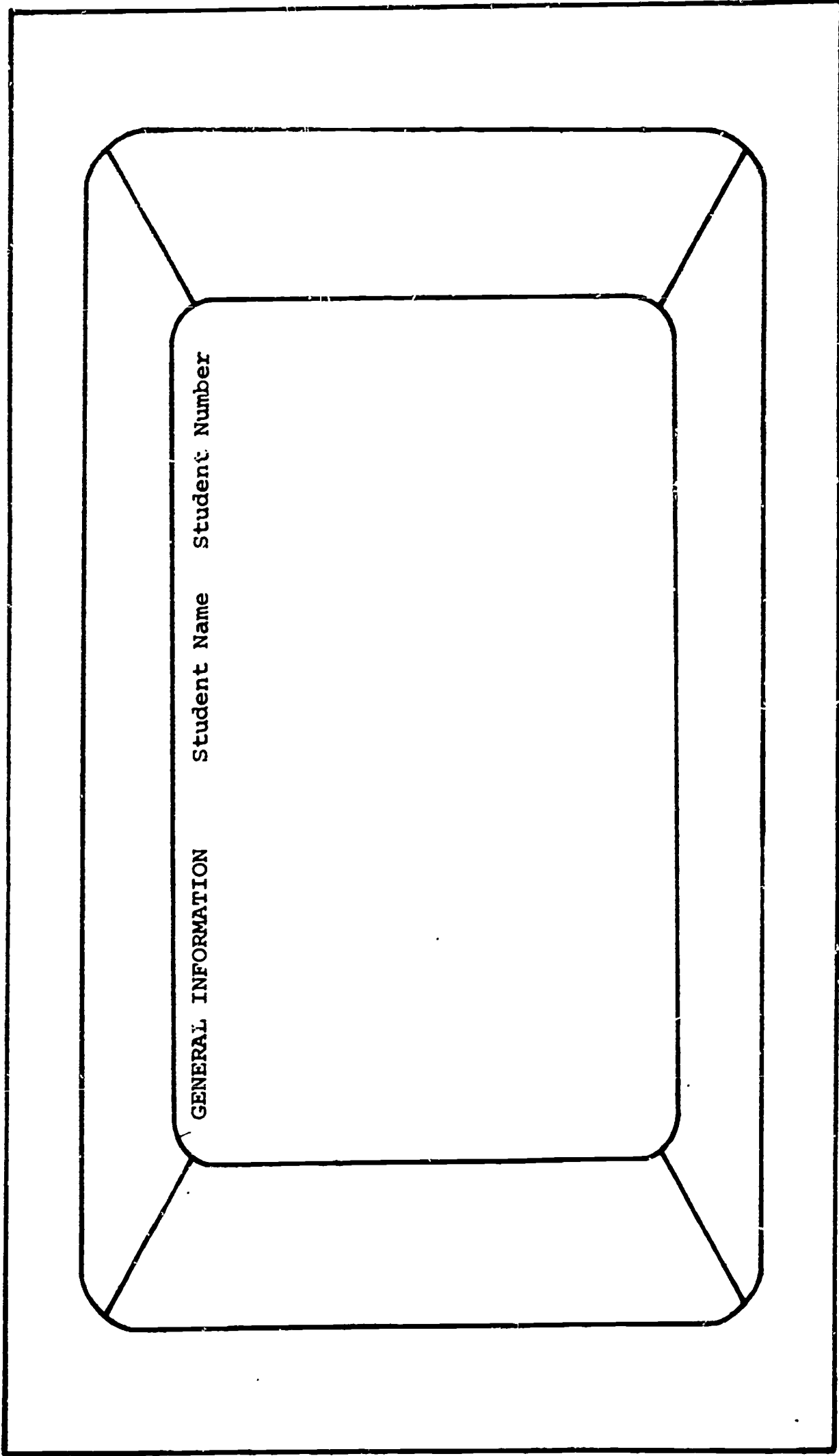

FIGURE 15

1. Counselor Inquiry - Health Record

HLRD/student number





FIGURE 15 (cont'd)

TGISS System Response

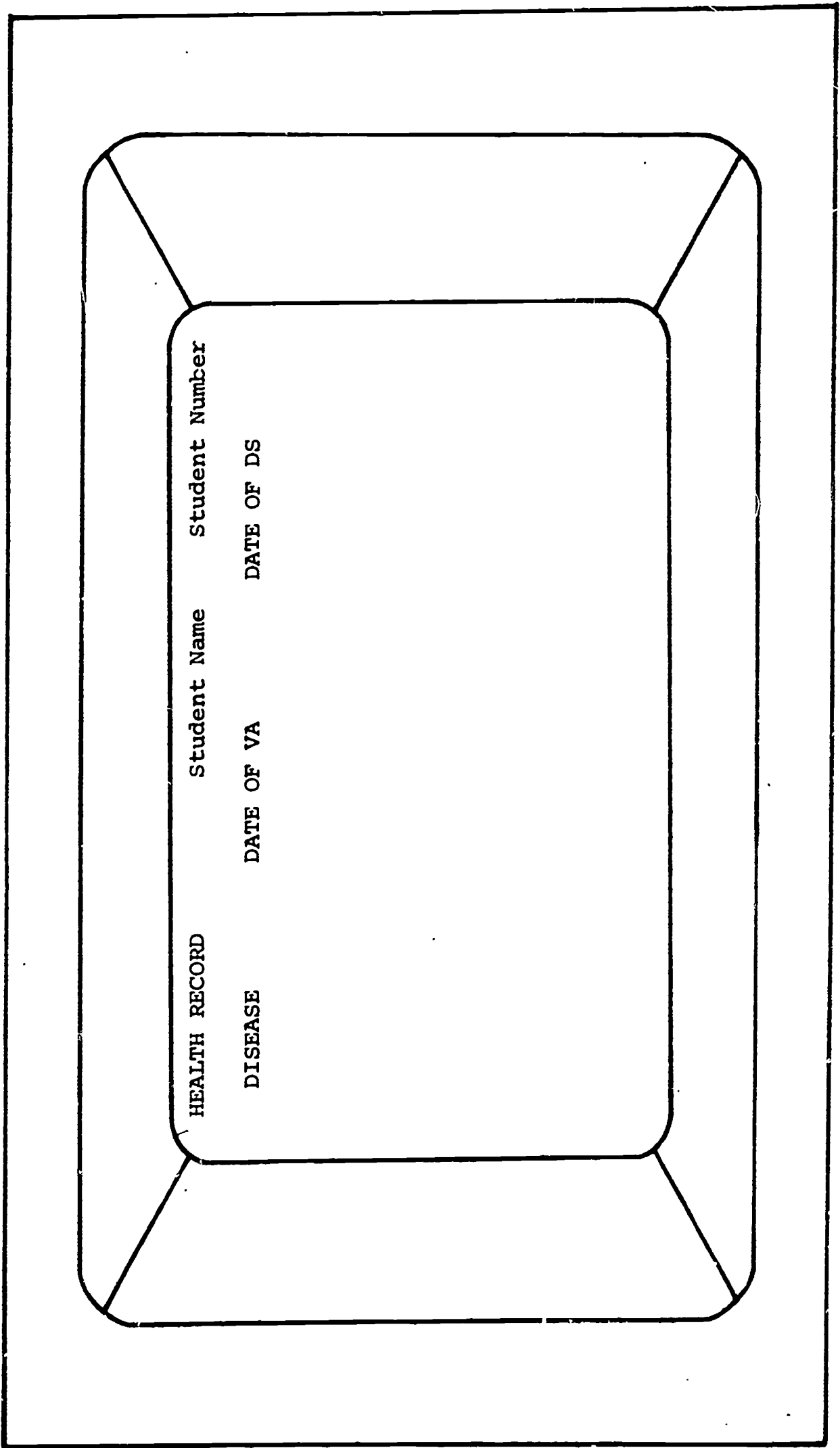

PART TWO

TGISS

SYSTEM INTERNAL DEFINITIONS

SYSTEM INTERNAL DEFINITIONS

Total Guidance and Information Support System (TGISS)

I. *Introduction*

This document defines the detail internals of the TGISS system in flow-chart form. Load and input verification and data update and revision programs are written in IBM/360 version-4 PL/1 language and the logic flow is by individual PL/1 statement in most instances. However, the primary function of the flowcharts is to establish logical flow and correct PL/1 statement format is not observed where a general non-PL/1 statement is more descriptive. The FASTER routines logic flow is presented in FASTER Macro language level. The FASTER Macros necessary to retrieve, format, and display TGISS student data are relatively 'high-level' in the FASTER system and are represented accordingly.

Section II is a general description of the programs in the TGISS system. Section III contains detailed logical flow of the programs and FASTER routines.

II. *System Description*

The major components of the TGISS software are:

1. Input Sort - Utilizing OS 360 Sort package to sort data cards by student ID and card code.
2. Load and input verification program.
3. Data update and revision program.
4. FASTER routines

All line control, message control, and terminal polling will be handled by the FASTER system and will not be detailed in this document. However, these functions are described in detail in the IBM documentation on FASTER (Filing and Source Data Entry Techniques for Easier Retrieval - 360D-06.7.C11).

A. TGISS SYSTEM FLOW

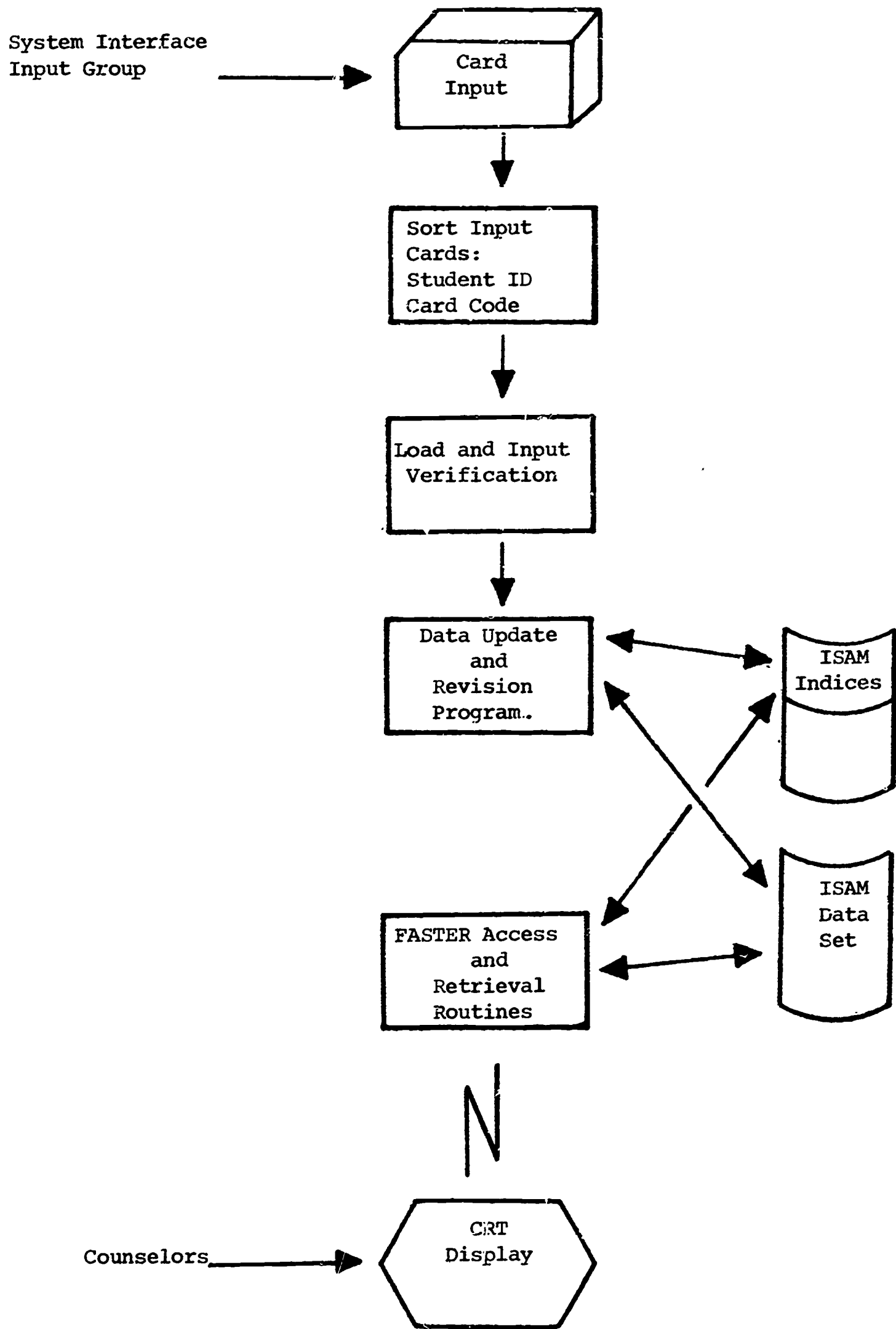

B. *Sort*

The sort of the input cards will be accomplished using the IBM 360 Sort/Merge program with appropriate job control language.

The cards will be sorted by student-ID-number (primary) and by second digit, then first digit in card-code (secondary). This sorting order will put the input cards in order by card-code within student-ID-number. This order will group all input cards for a specific student together for input to the load and input verification routine. The cards for a particular student will be in order by card-code, 01 through 0B. Sorted card columns:

Student-ID-Number - card columns 1-6

Card-code - 2nd digit card column 80

1st digit card column 79

C. *Load and Input Verification Program*

The load and input verification program (VERY) combines all the input cards for a particular student-ID-number into a single student data record. This data record is then written and passed on to the data update and revision program. Specific functions accomplished in the load and update verification program are:

1. Verify that each group of student data cards has a master card (01).
2. Verify that student-ID-number is numeric.
3. Verify that student name is not blank.
4. Verify card code as A, R, or blank.
5. Verify course credit field as a value or zero.

6. Courses which have been input twice because of a data error are defined by the load and update verification program.
7. Write cards with blank or erroneous card codes to error list.
8. Combine all cards related to a student into one student data record.
9. Generate update transactions for the TGISS data file for:
 - a) Weekly absences - card code OC
 - b) Current schedule - card code OD
 - c) Nine-week GPA's - card code OE.

D. *Data Update and Revision Program*

The update and revision program accepts the output of the load and verification program as input and performs the function directed by the TOA (Type-of-Action) code in the input record. A TOA of (A) designates that a record will be added to the TGISS student data base. A TOA of (R) will designate that a record already in the TGISS student data base will be revised. A TOA of (D) will designate that the student record having the same key as the student-ID-number in the input record will be deleted from the data base. A TOA of (B) will update the absence record portion of a student's data record. A TOA of (C) will place a student's current schedule in his student data record. A TOA of (G) will add a student's 9-week grade point average to his student data record. Specific functions accomplished by this program are:

1. Creation of the initial ISAM data set from input records.
2. Computation of student grade averages when student is added to the data base and at any point that a student's data record is revised to include additional courses taken and passed.

3. Add student data records to the data base.
4. Revise student data records already in the data base.
5. Delete student data records from the data base.

Most student data record revision can be accomplished at the data field level. Exceptions will be documented in the TGISS Update and Revision Specifications.

E. *FASTER Access Routines*

FASTER is an IBM type three program which will be used to access and retrieve data from the TGISS ISAM data set. A Macro language provides a means of writing message processing and data display programs on a data format and functional logic level. Transaction processing descriptions (TPD's) will describe the ISAM data set, the inquiry formats, and the desired output to the FASTER system. The line control and message control is furnished by defining to the FASTER system the TGISS users terminal configuration, the inquiry format, and stages to be processed. The user's module will be flow-charted in this document; further information on FASTER requirements may be found in the reference listed in Section II, System Description.

III. *FLOWCHARTS*

- A. VERY - Load and input verification program
- B. UPDAT - Data update and revision program
- C. FASTER routines

VERY

Load and Input Verification Program

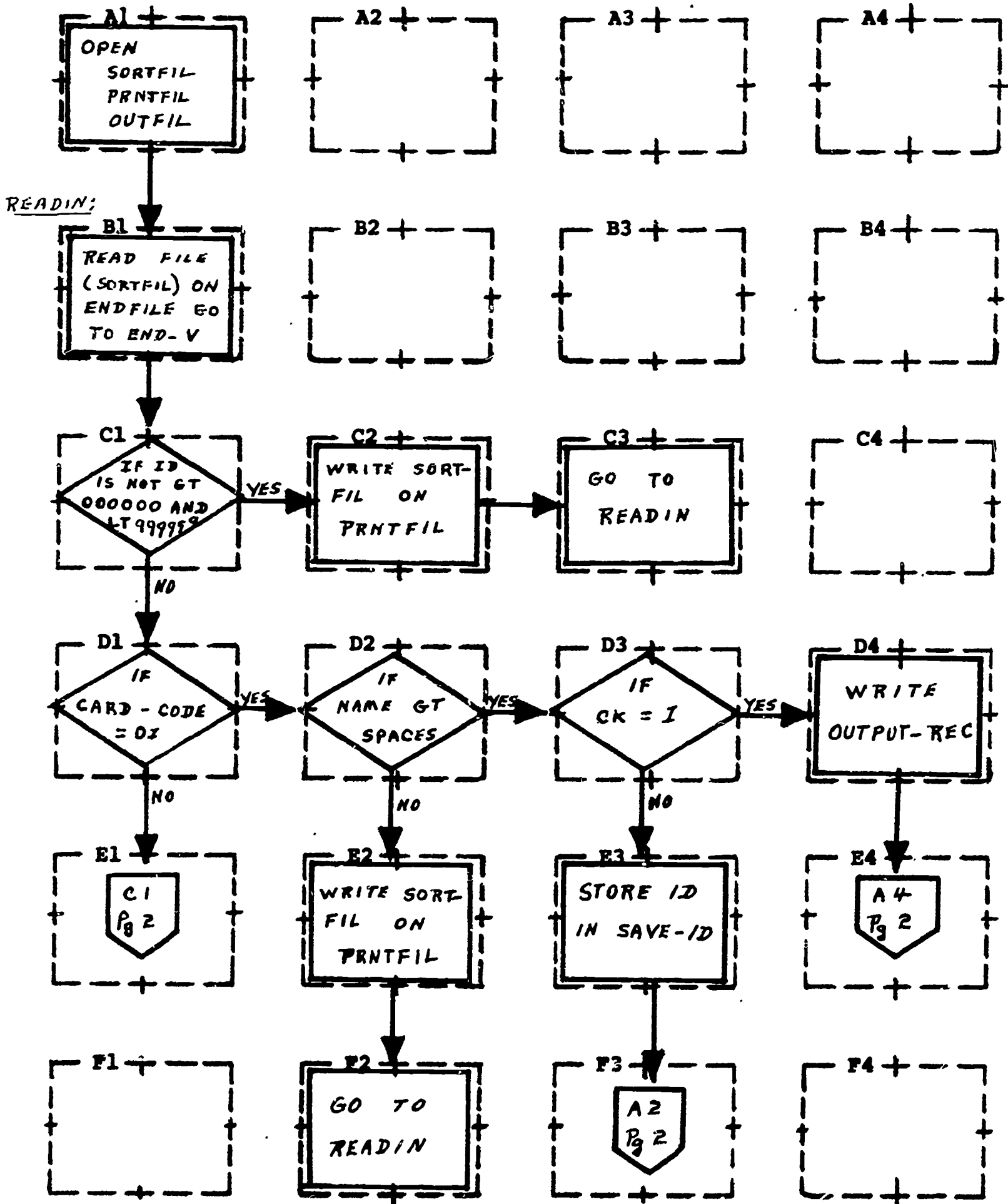
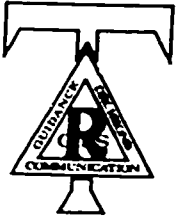

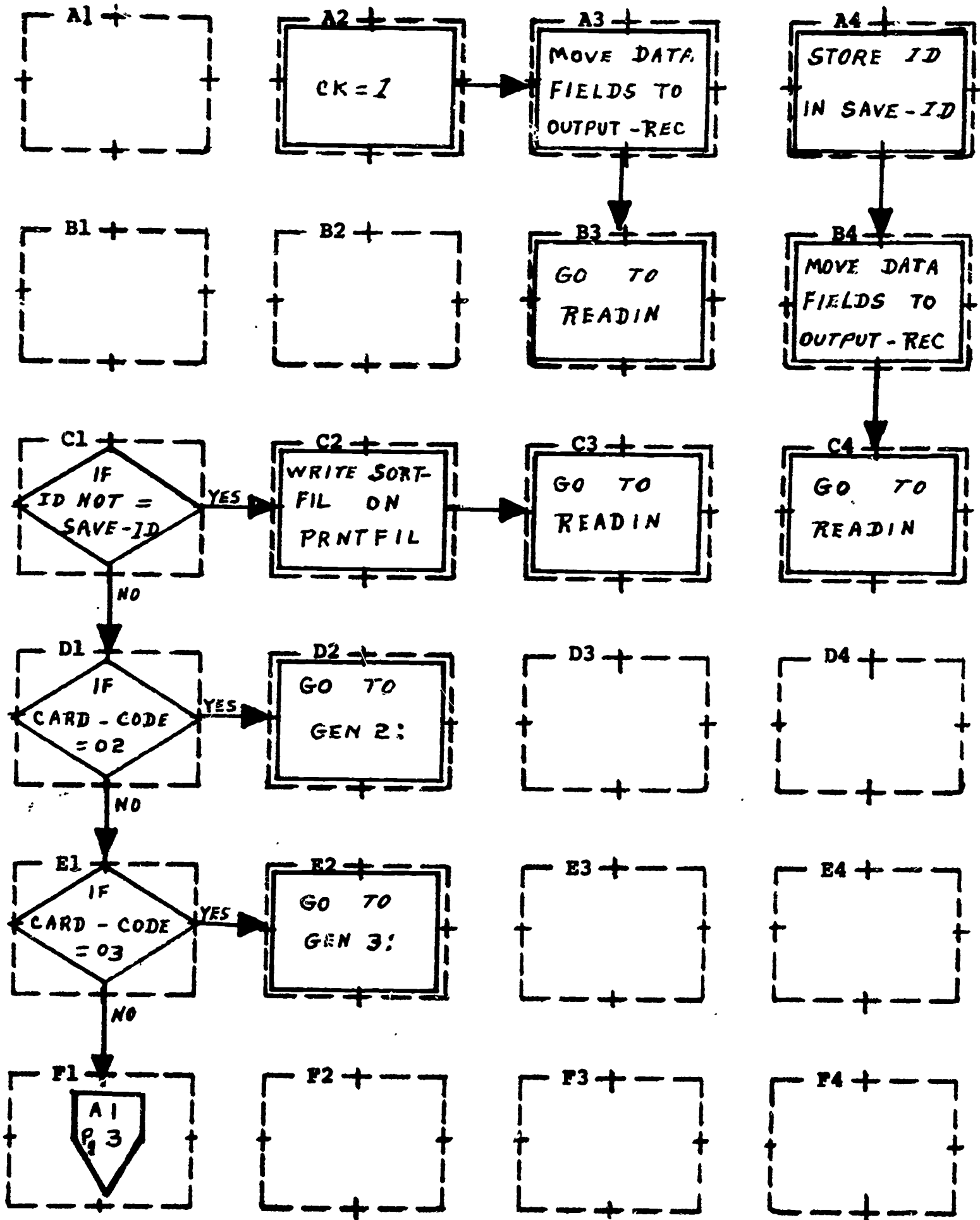



Title: VERY

Page: 3

Chart: Input Verification

Date: 7/3/69

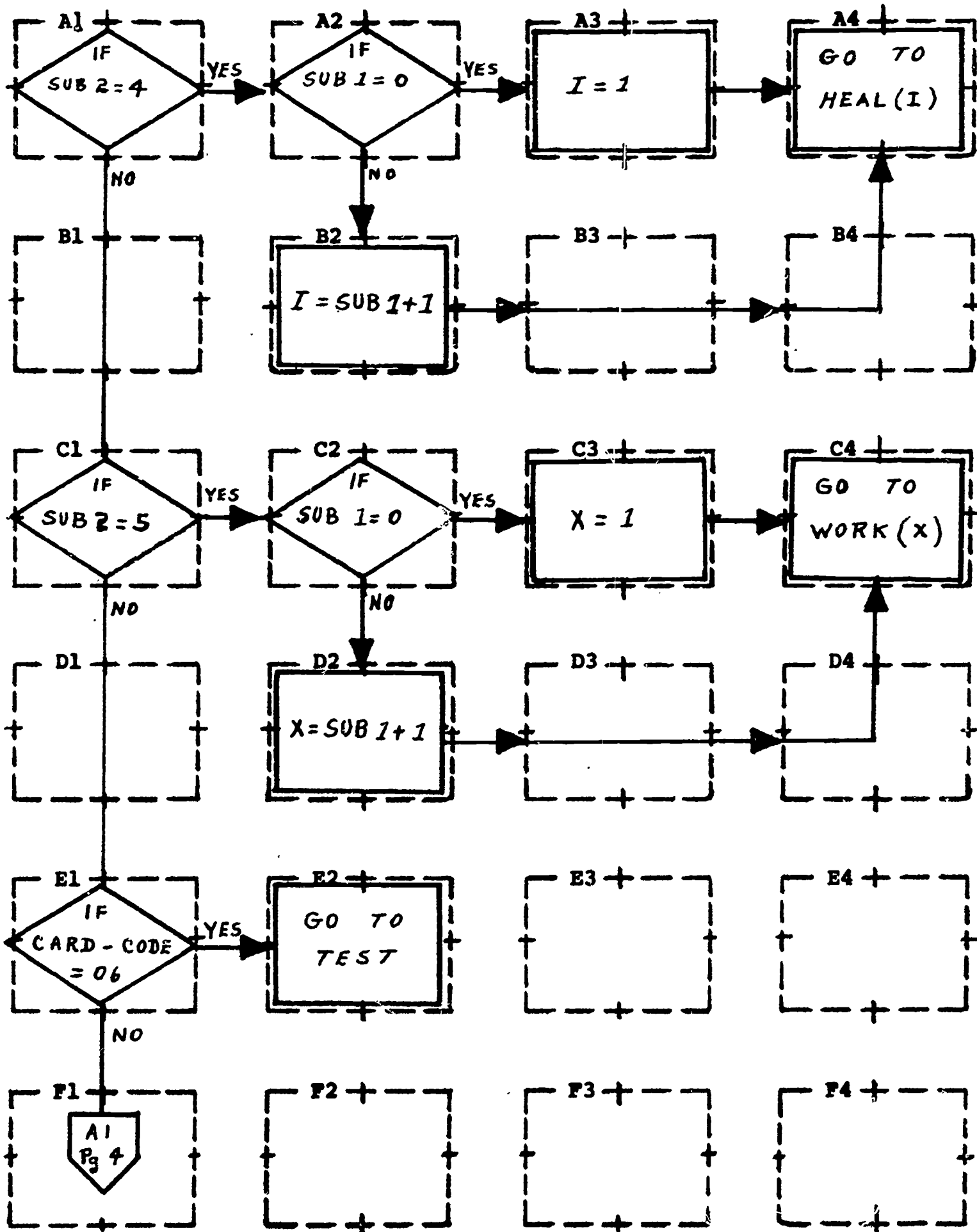

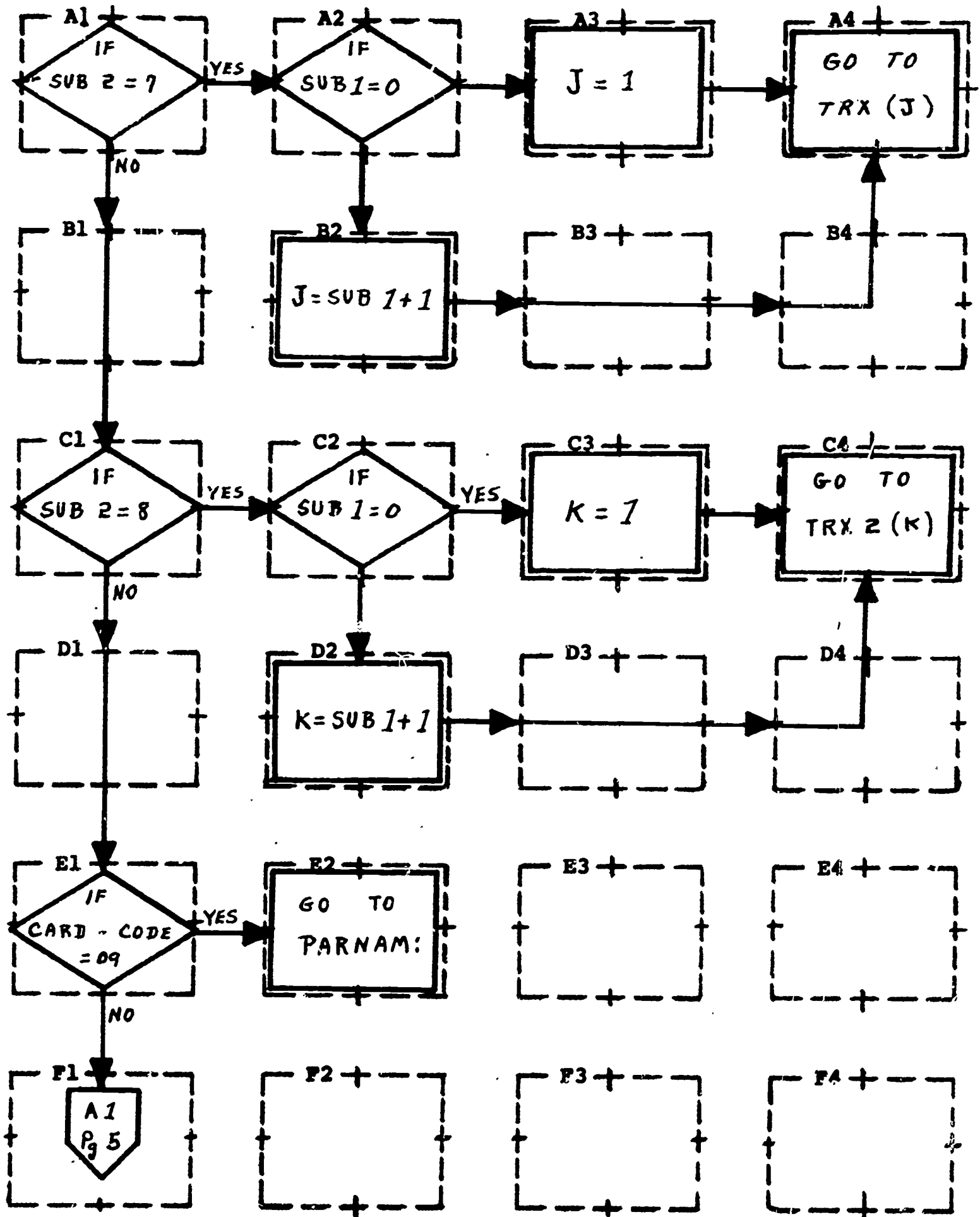

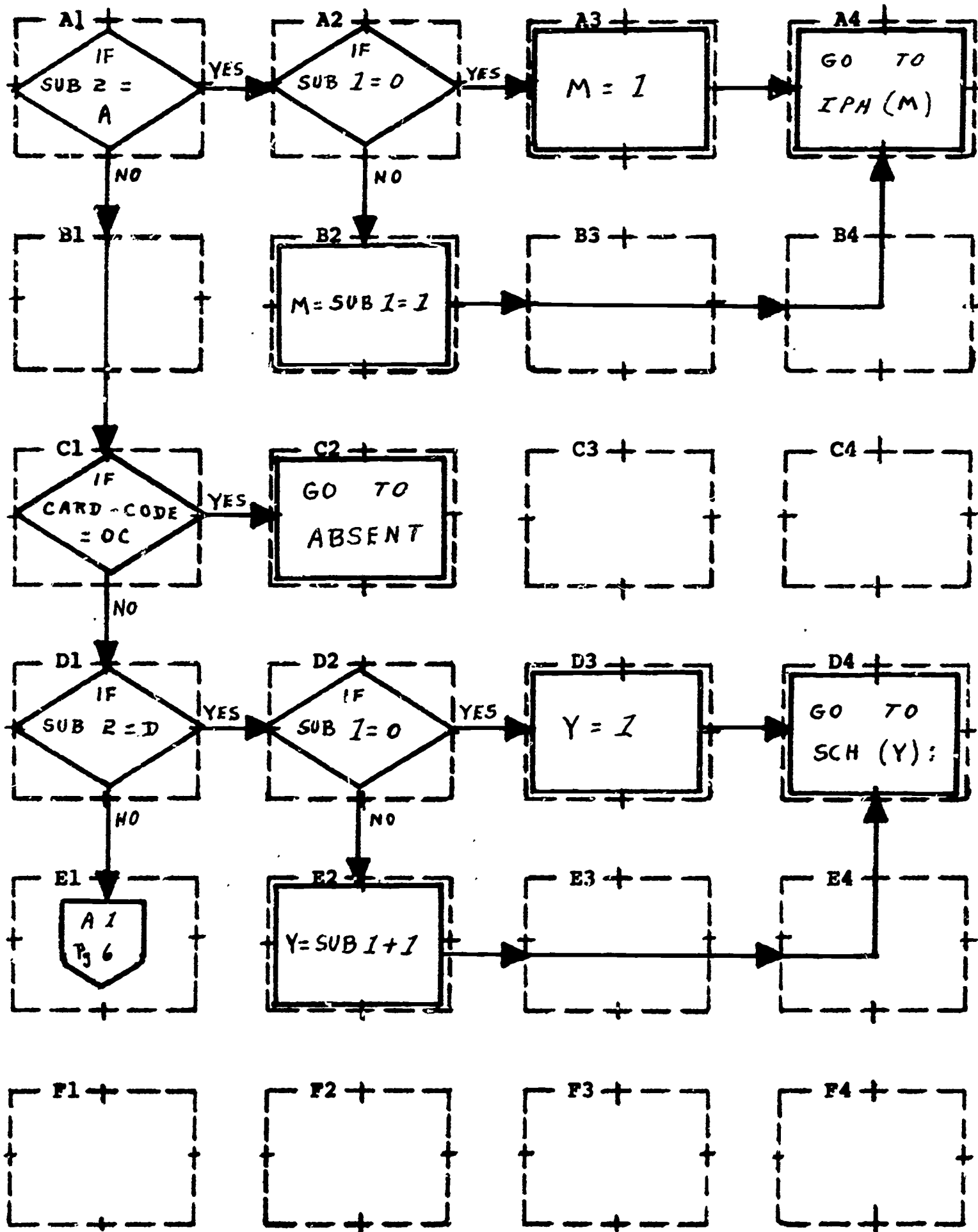

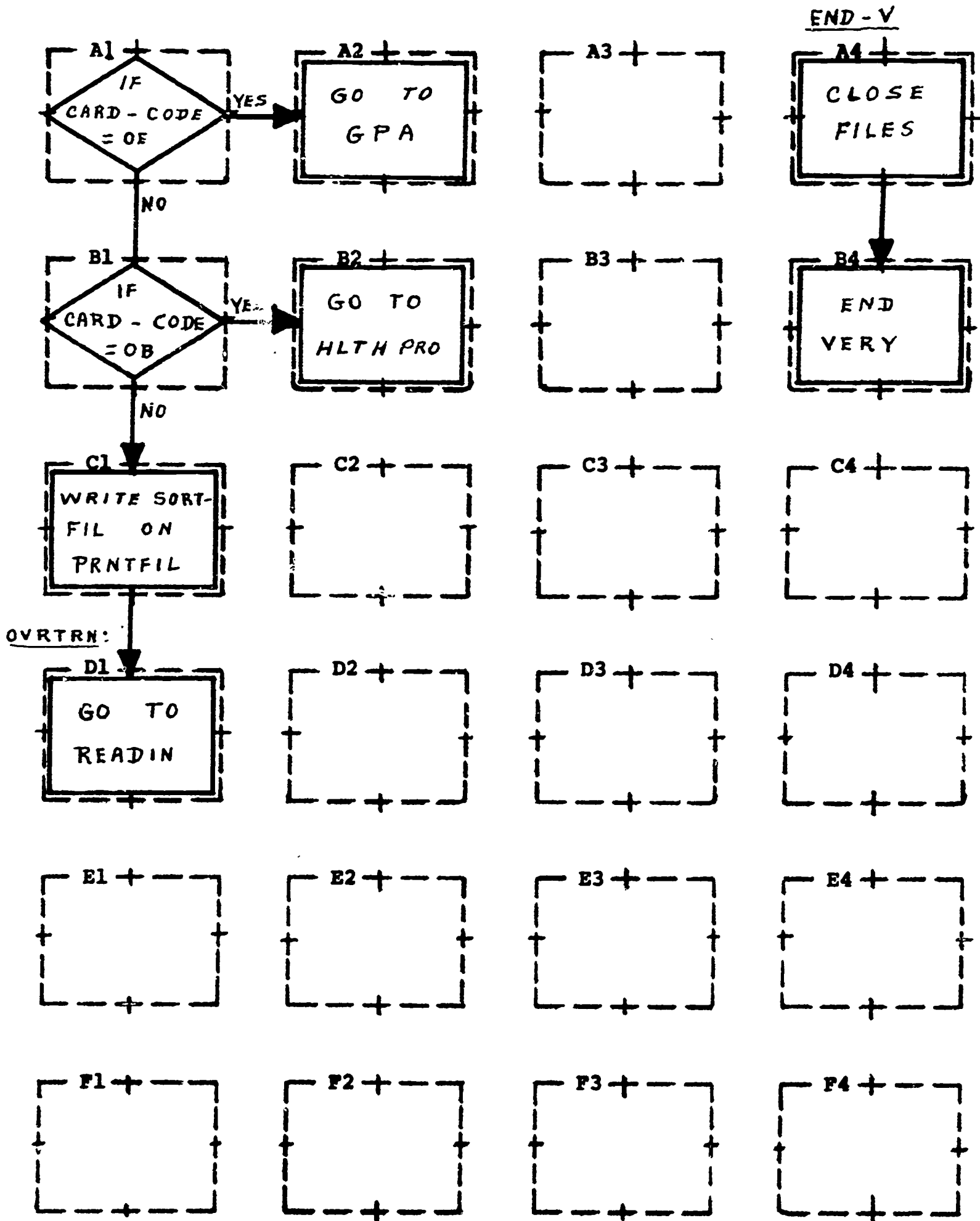



Bartlesville Public Schools - TGISS

Title: GEN 2 Page: 1

Chart: Input Verification Date: 7/3/69

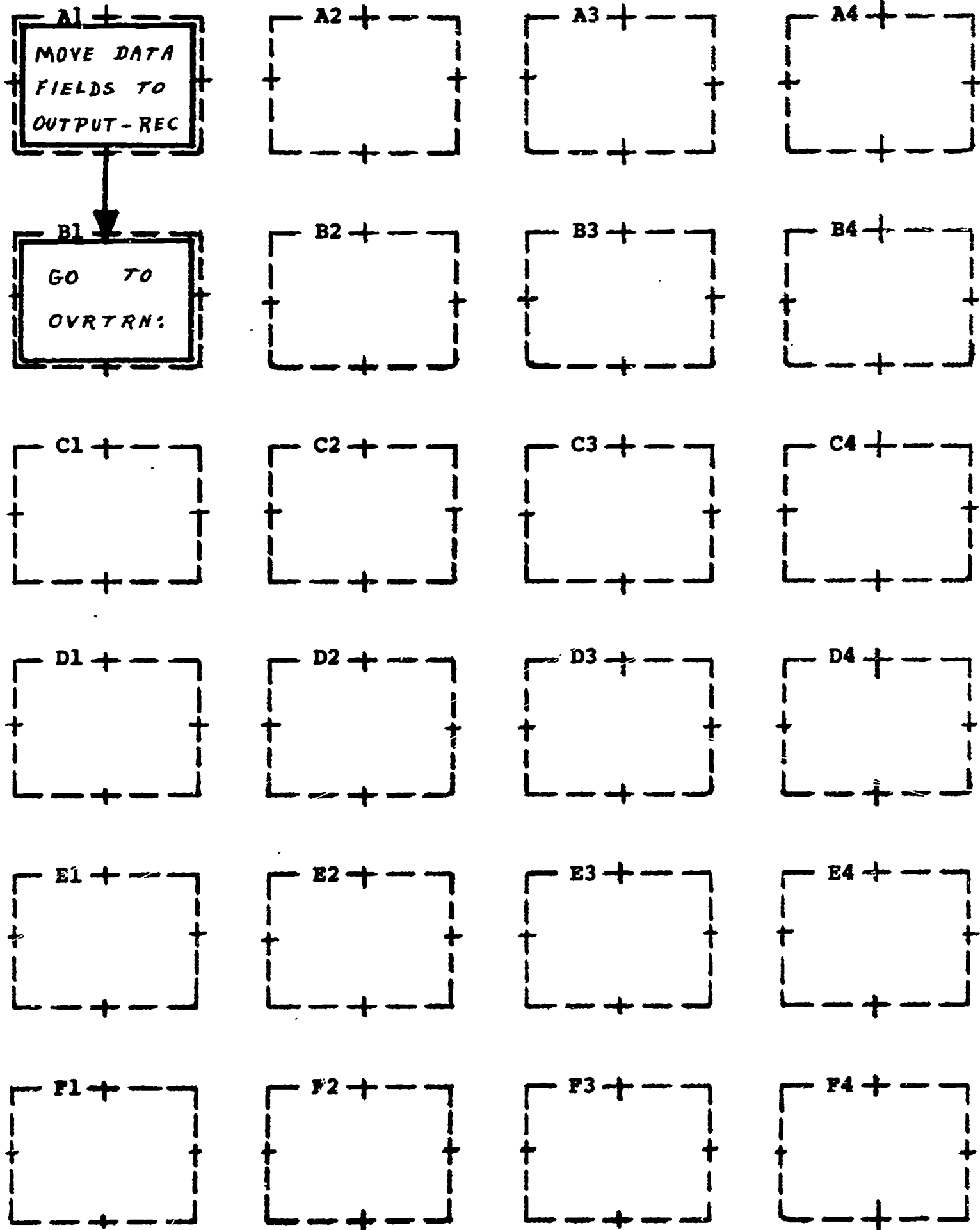

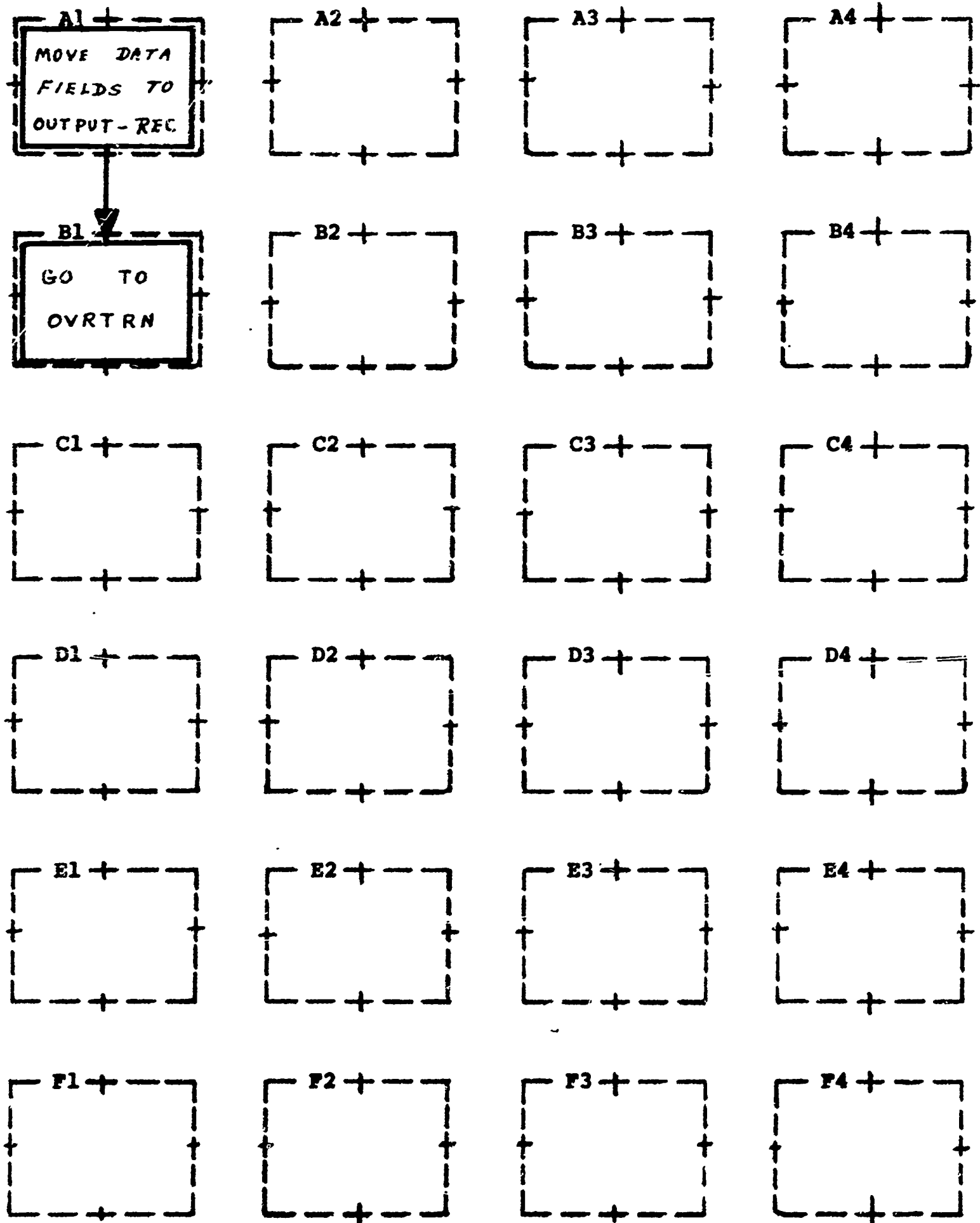

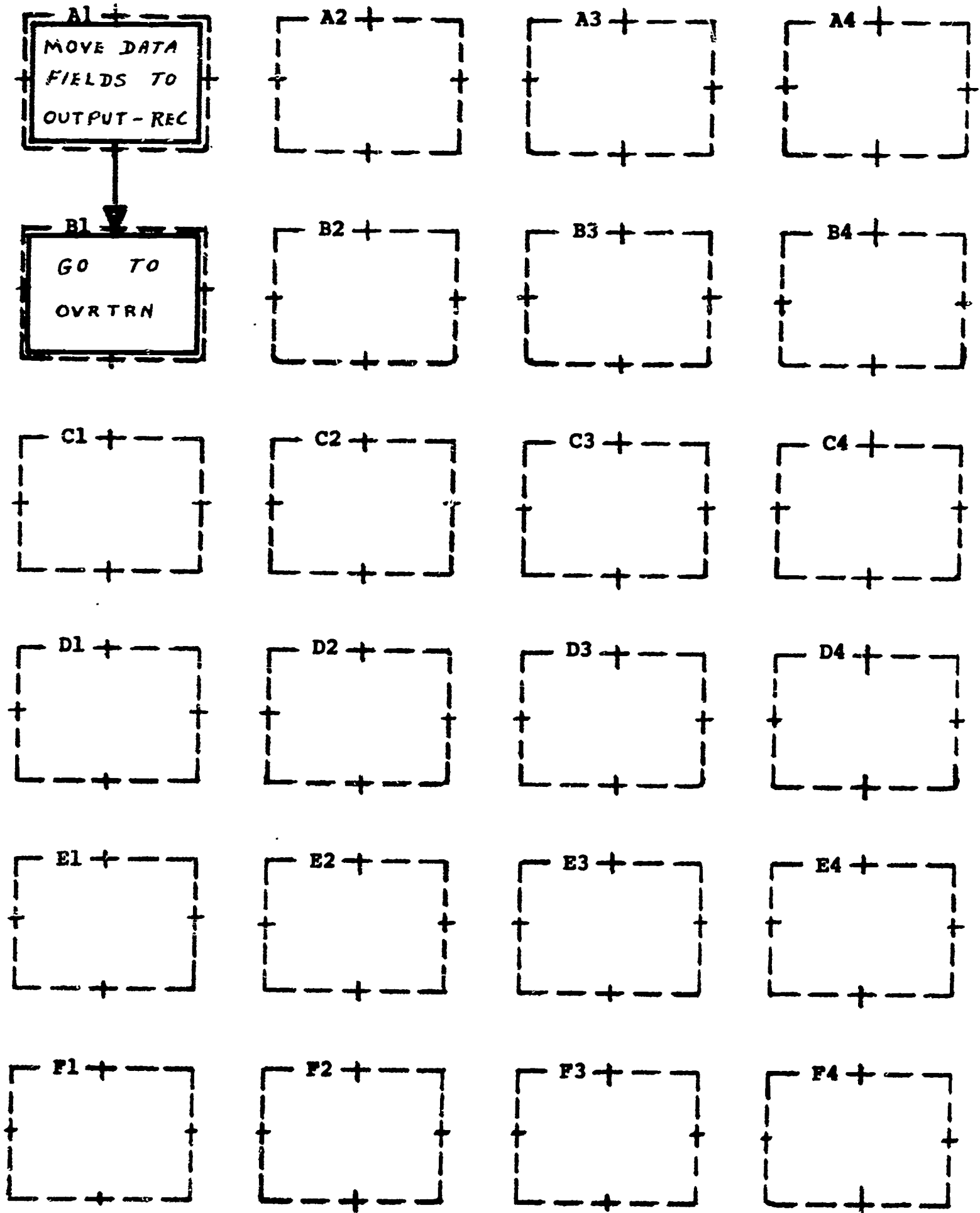
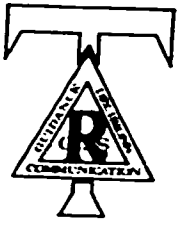

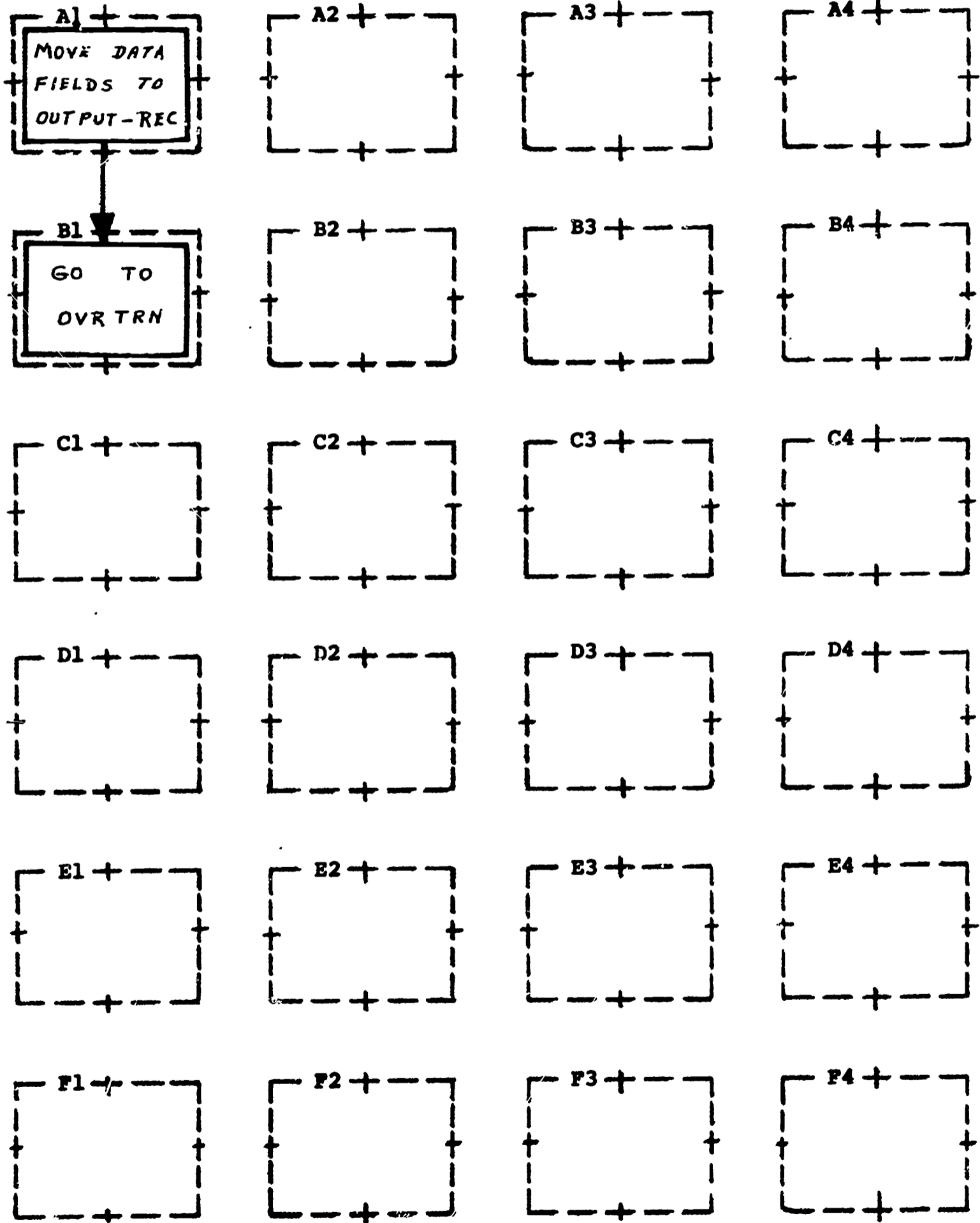

Bartlesville Public Schools - TGISS

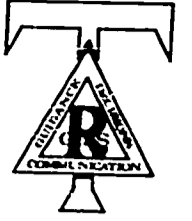

Title: IPH (M) There are 5 such groups

Page: 1

Chart: Input Verification

Date: 7/7/69

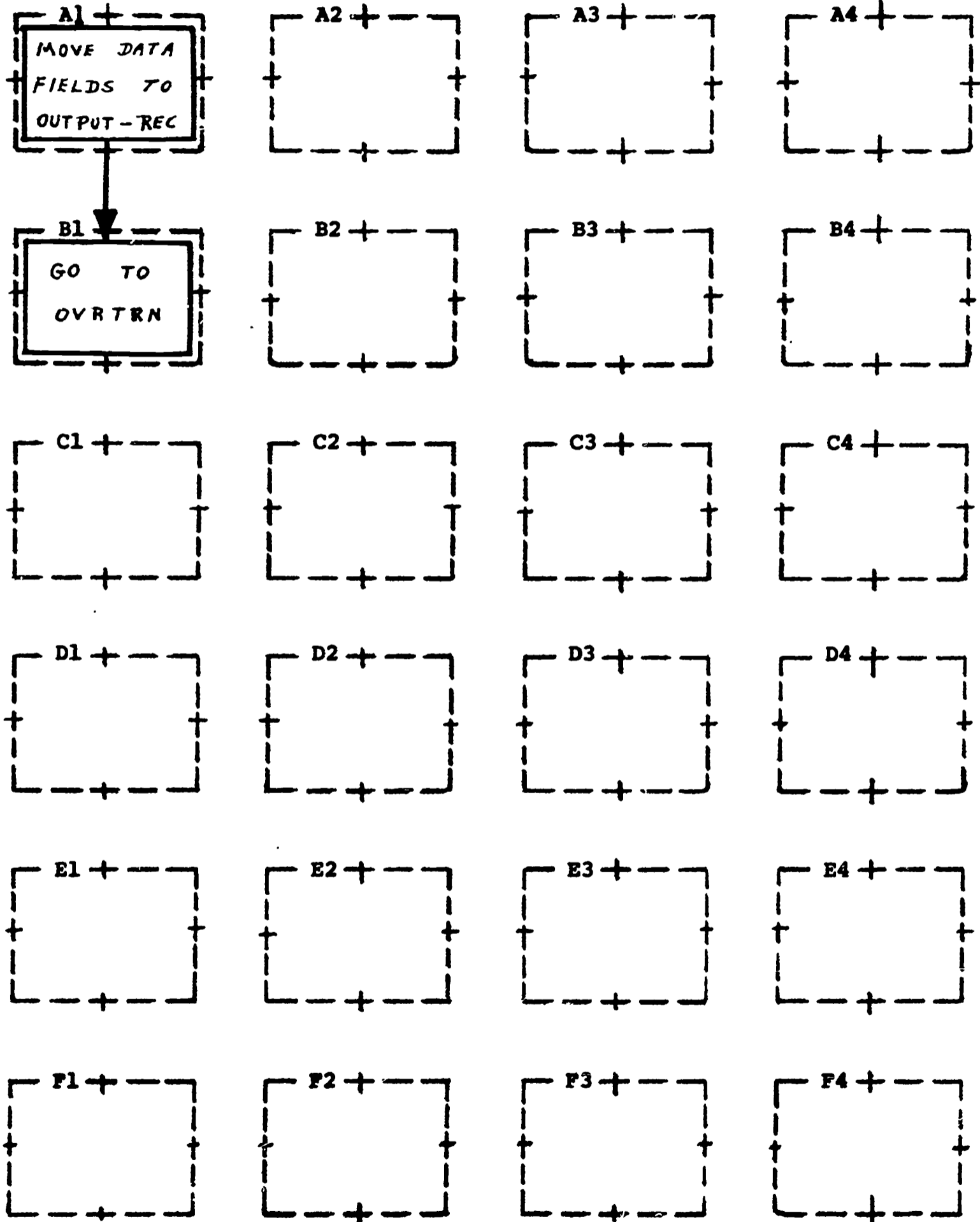



Title: TEST

Page: 1

Chart: Input Verification

Date: 7/7/69

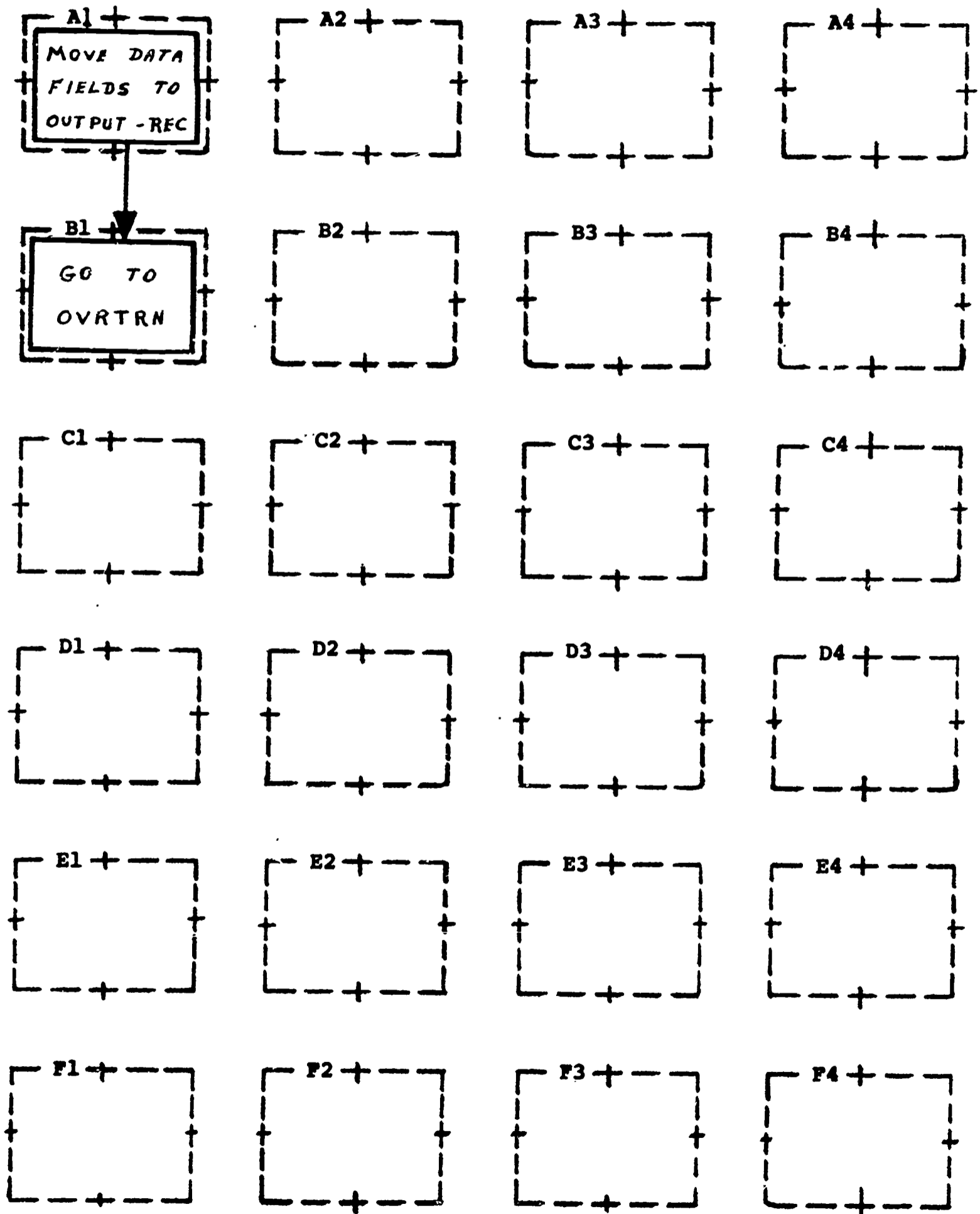

Bartlesville Public Schools - TGISS

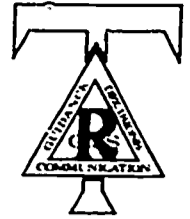

Title: PARNAM

Page: 1

Chart: Input Verification

Date: 7/7/69

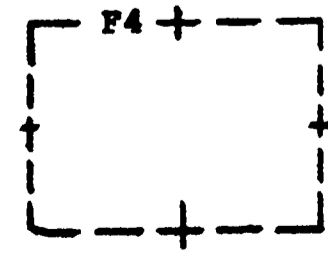
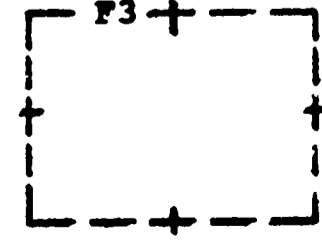
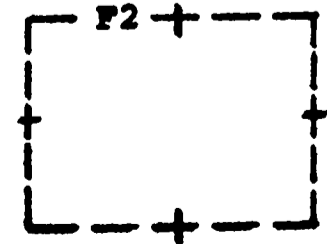
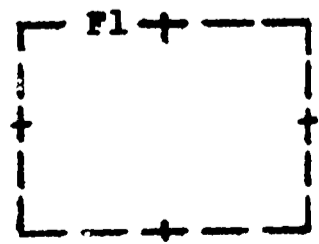
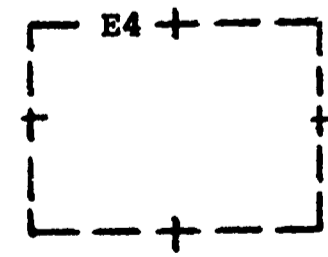
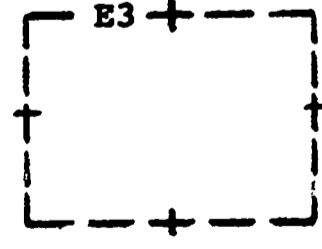
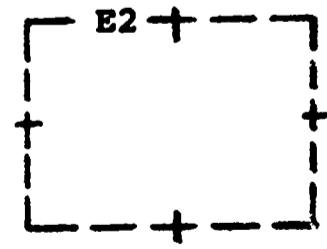
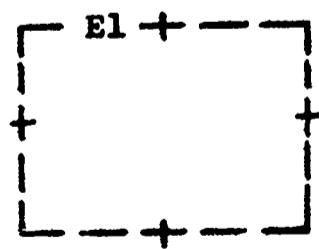
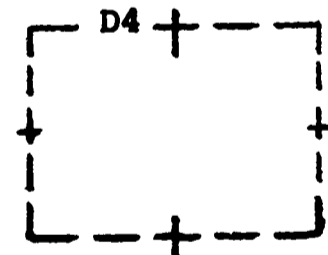
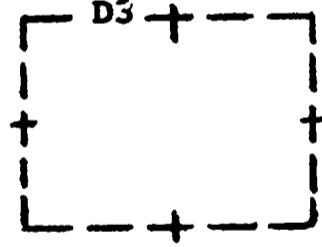
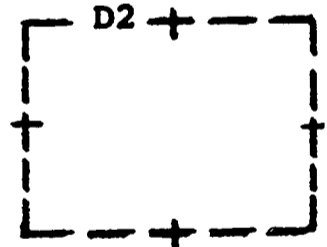
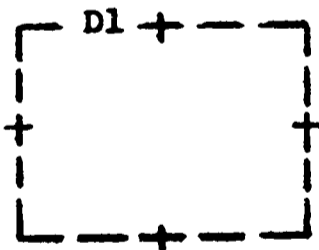
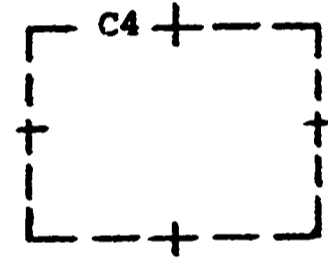
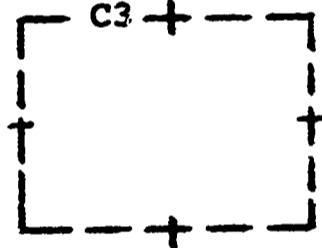
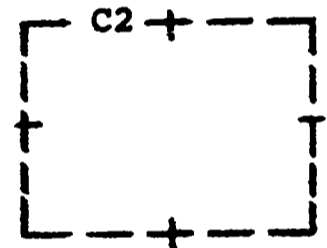
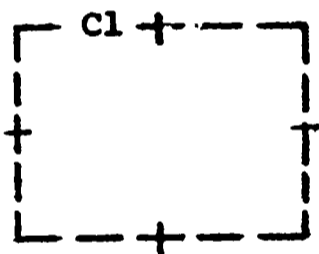
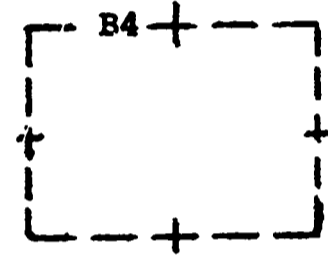
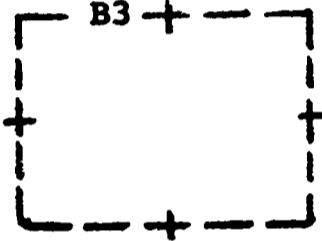
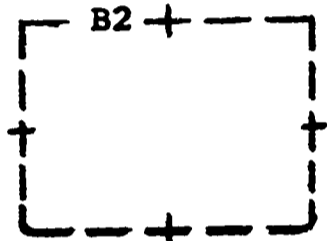
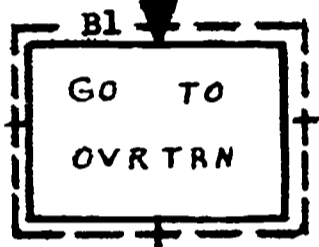
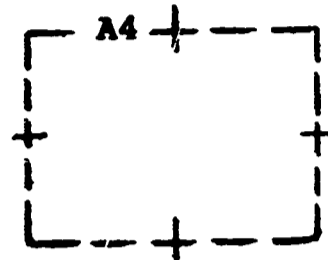
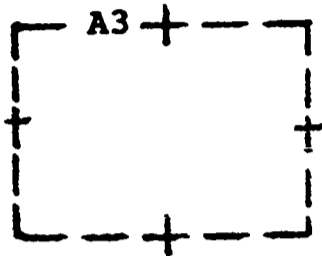
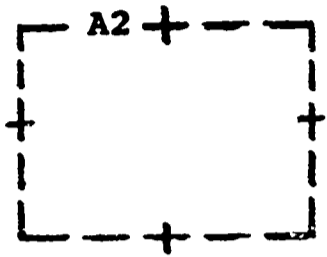
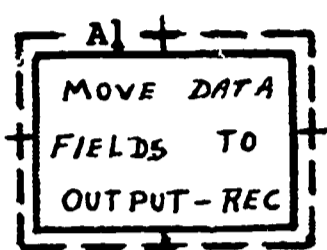

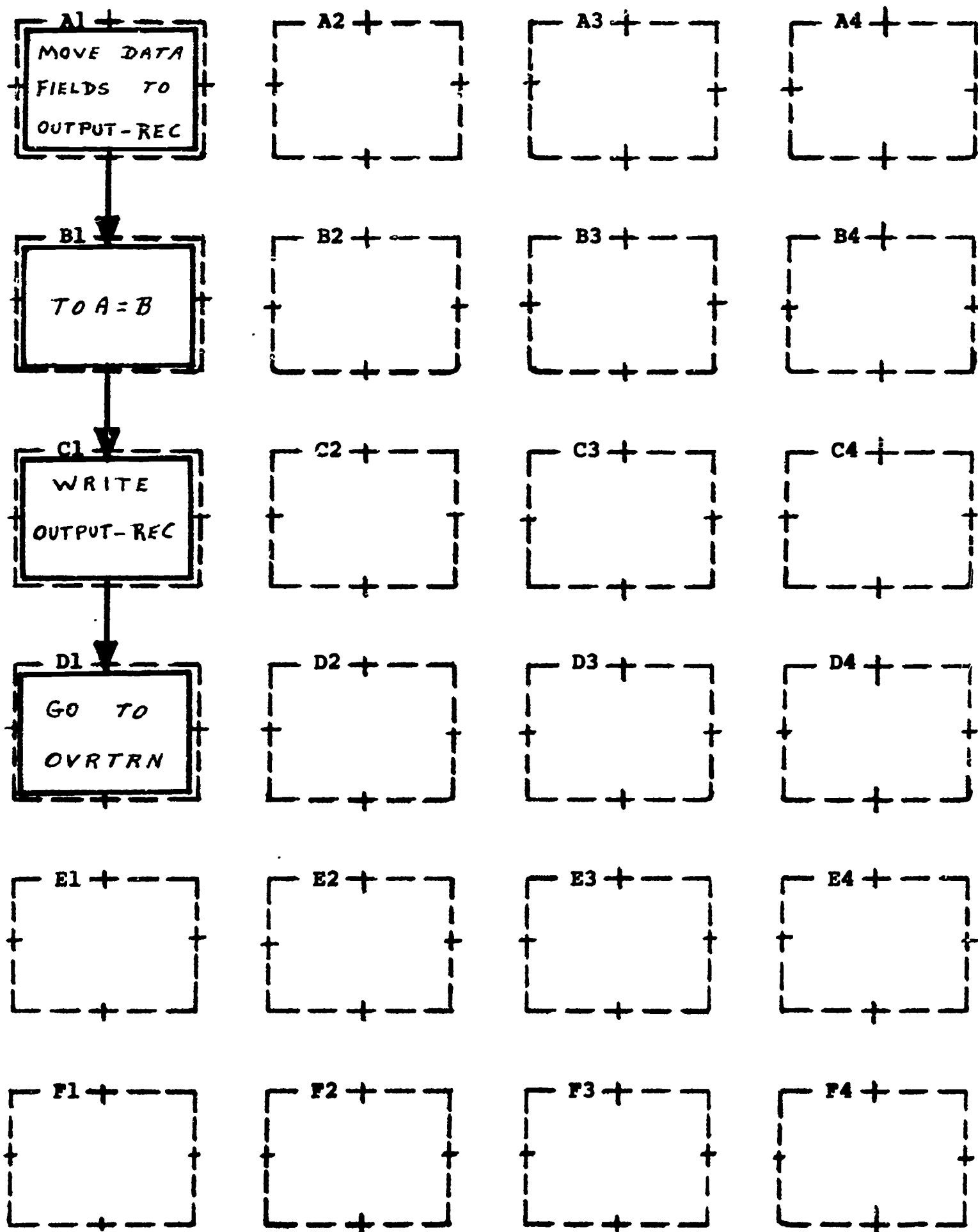

Bartlesville Public Schools - TGISS



Title: GPA

Page: 1

Chart: Input Verification

Date: 7/7/69

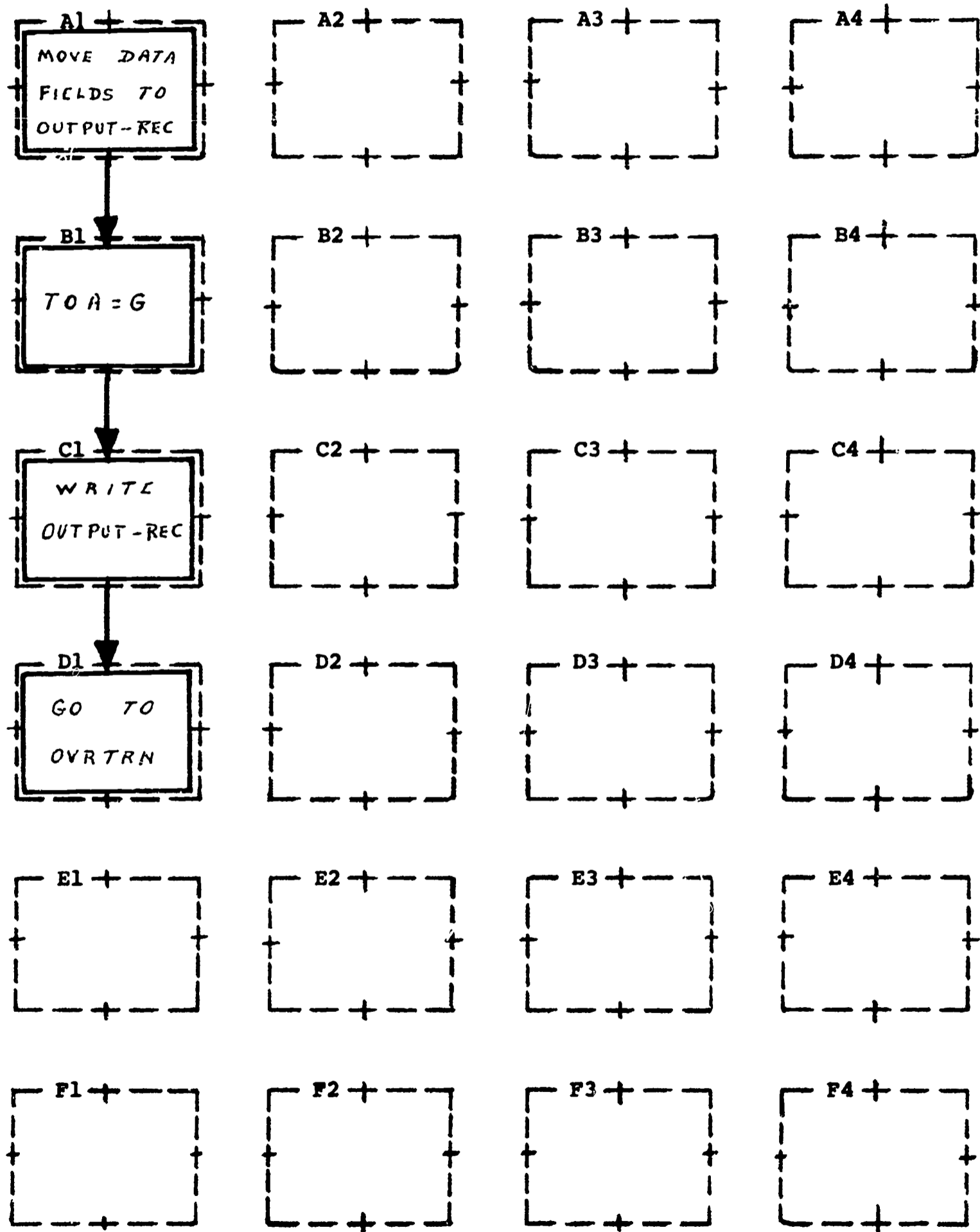

Bartlesville Public Schools - TGISS

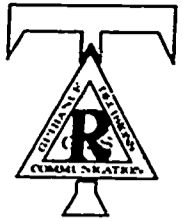

Title: HLTHPRO

Page: 1

Chart: Input Verification

Date: 7/7/69

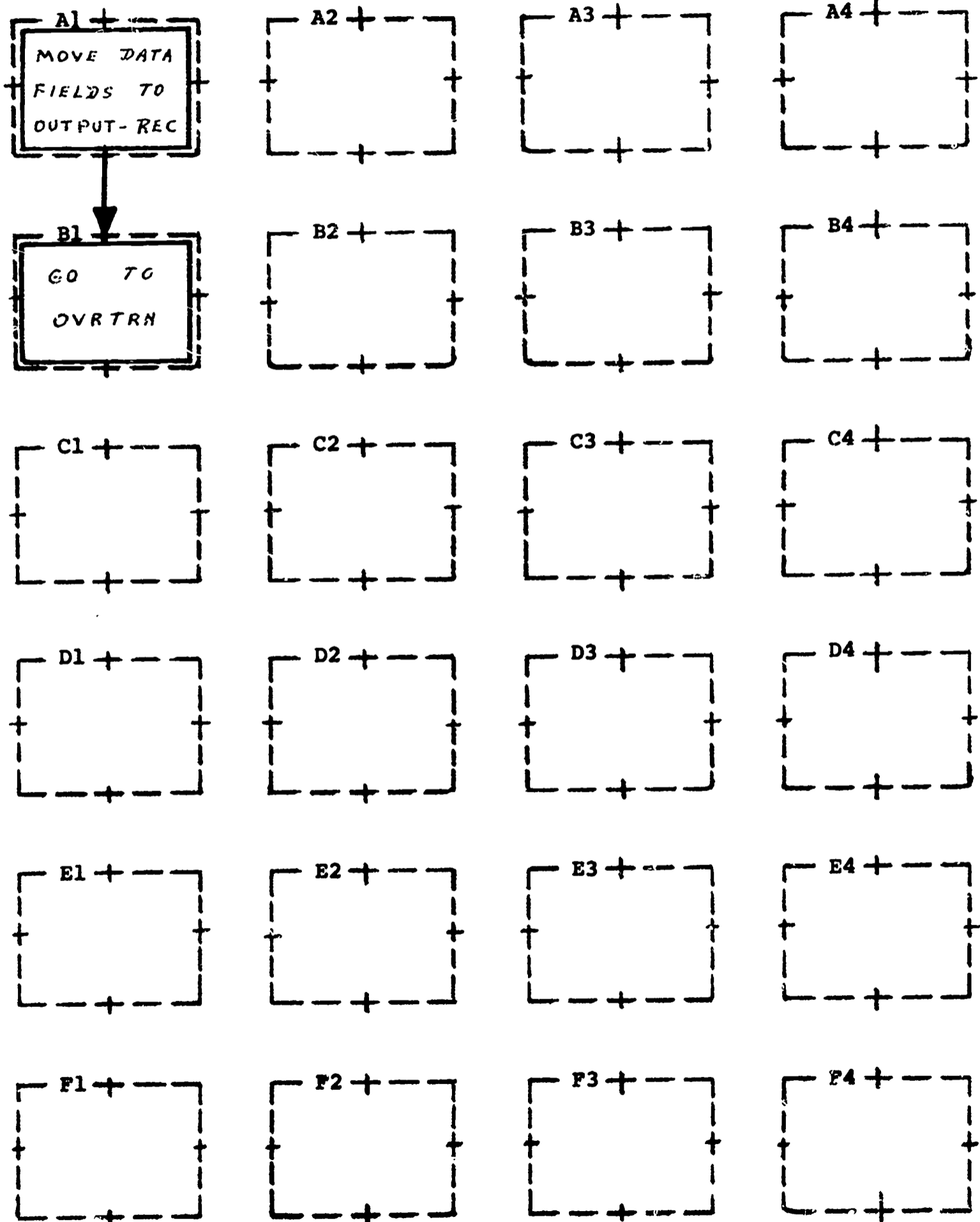

Bartlesville Public Schools - TGISS

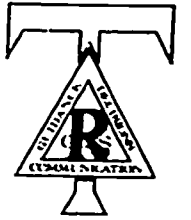

Title: TRX1(J) There are 3 such groups

Page: 1

Chart: Input Verification

Date: 7/7/69

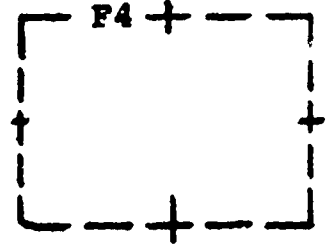
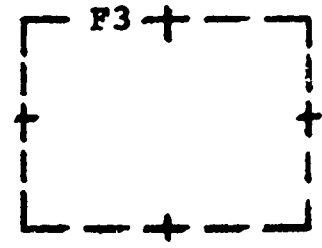
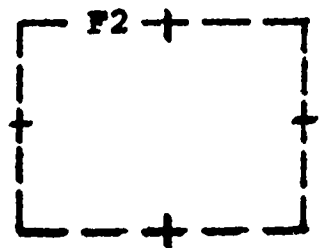
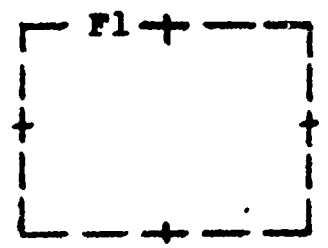
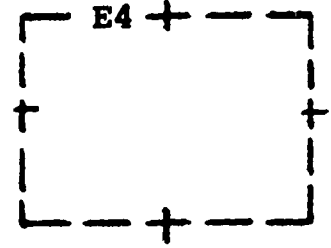
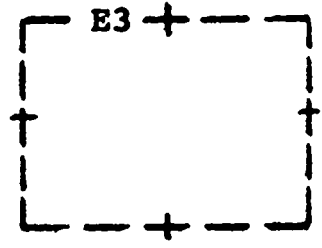
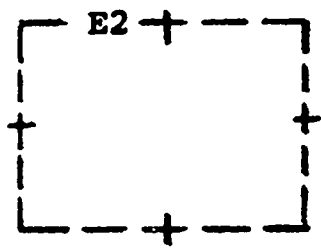
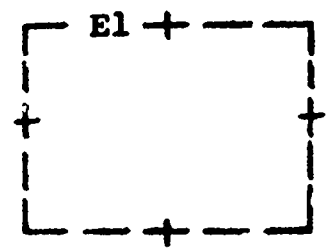
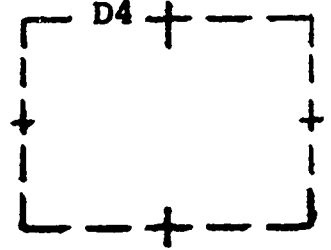
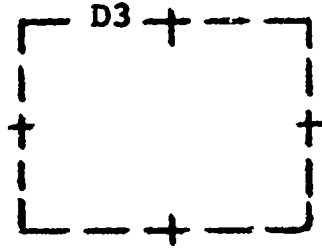
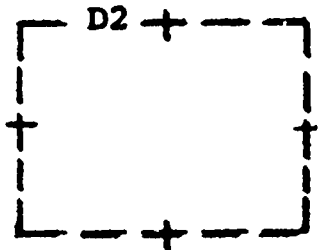
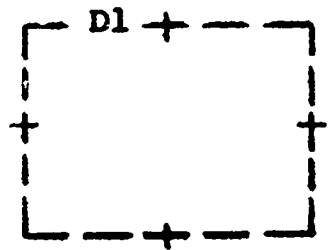
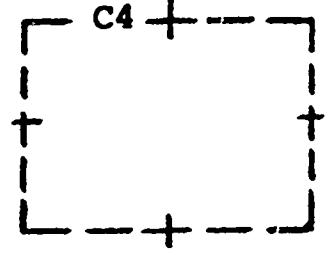
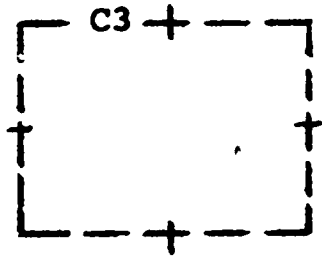
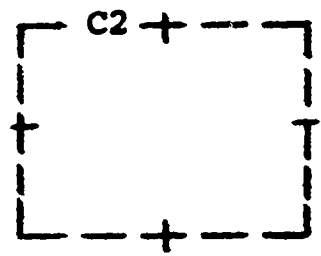
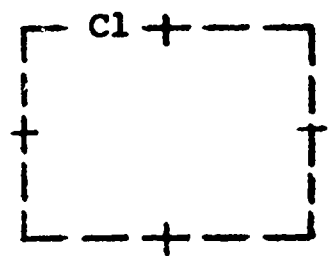
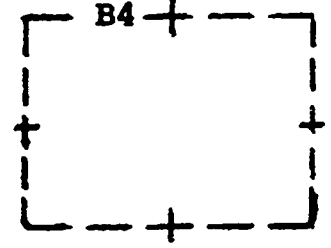
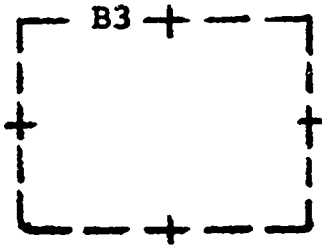
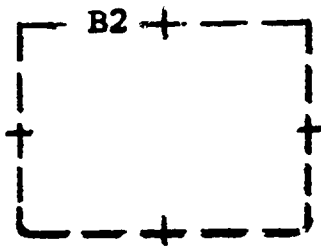
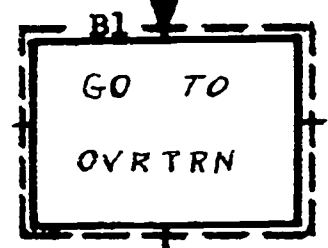
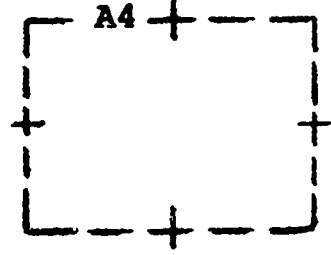
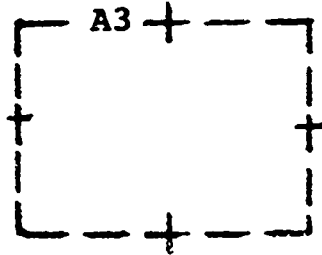
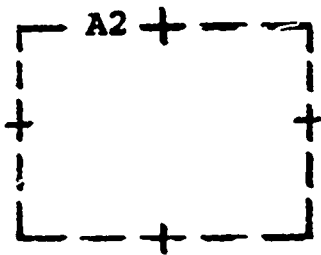
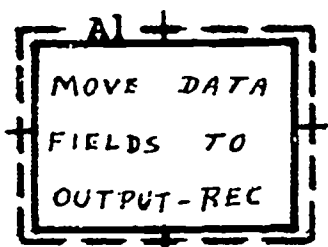



Bartlesville Public Schools - TGISS

Title: TRX2(K) There are 9 such groups

Page: 1

Chart: Input Verification

Date: 7/7/69

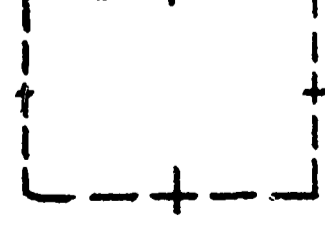
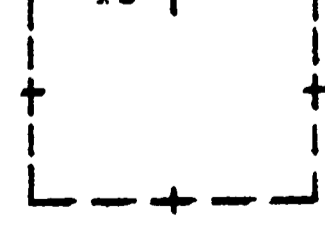
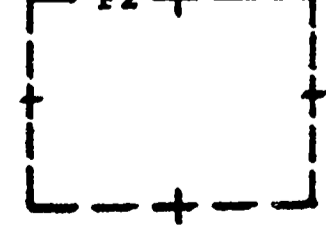
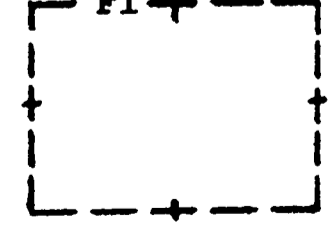
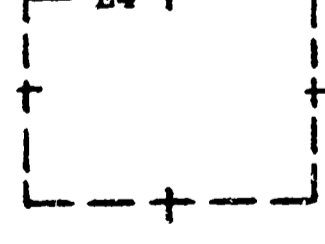
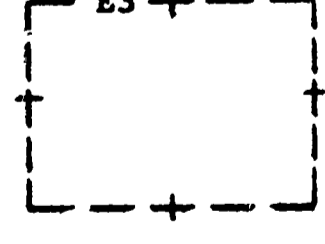
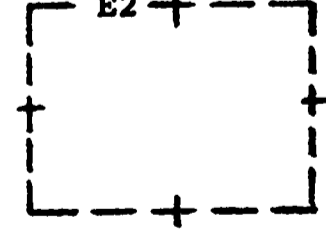
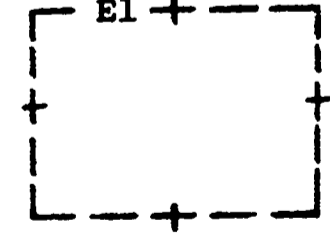
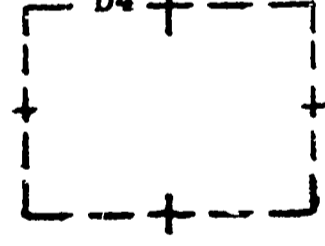
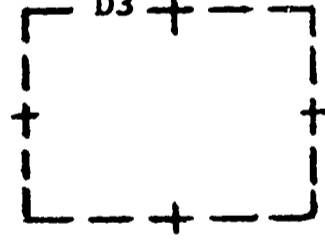
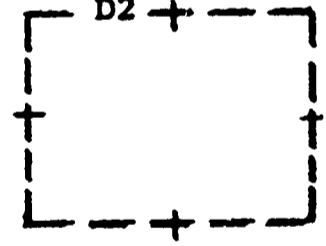
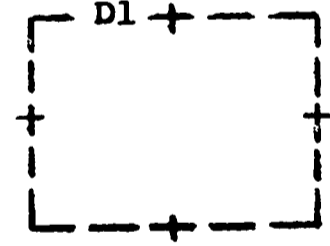
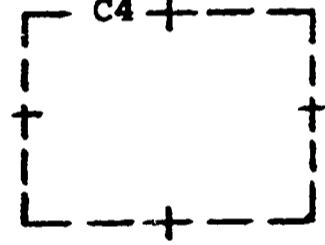
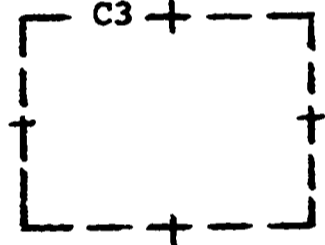
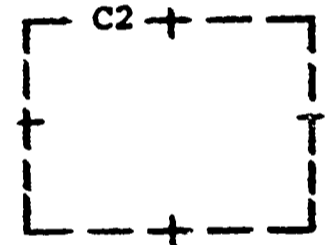
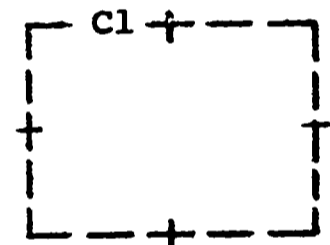
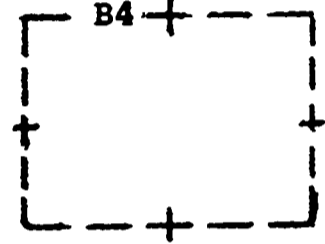
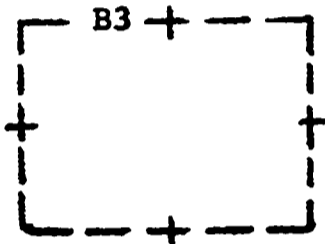
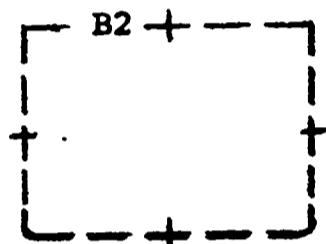
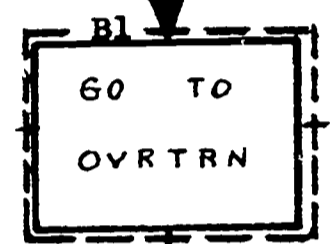
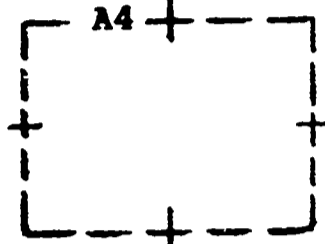
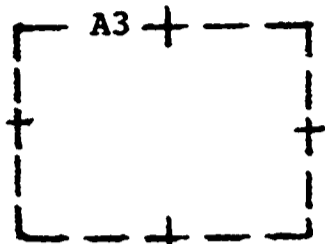
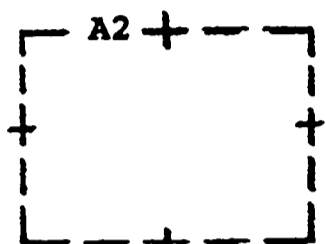
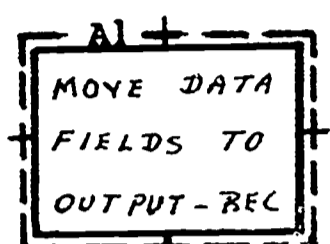

Bartlesville Public Schools - TGISS



Title: SCH(Y) There are 4 such groups

Page: 1

Chart: Input Verification

Date: 7/7/69

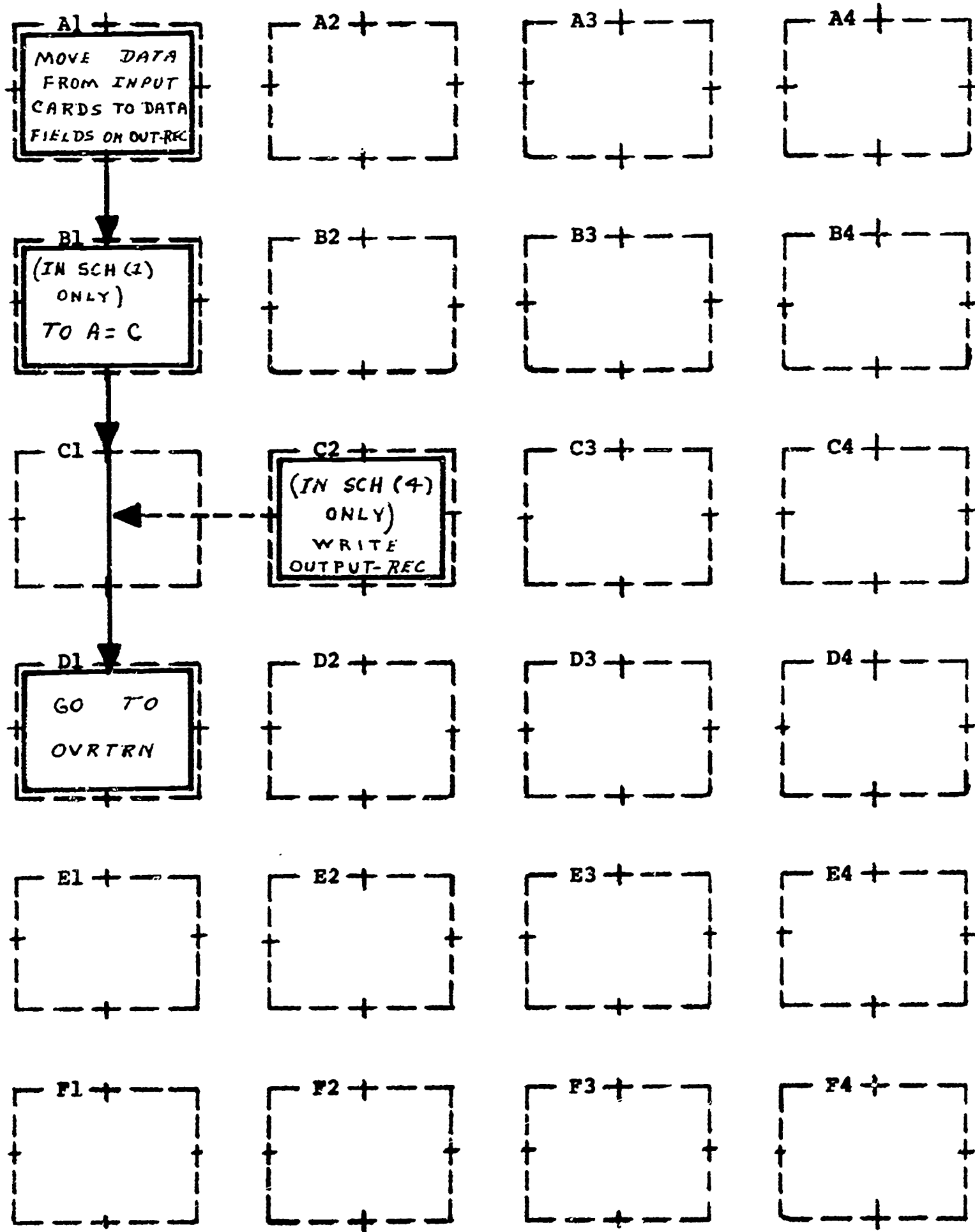

UPDAT

Data Update and Revision Program

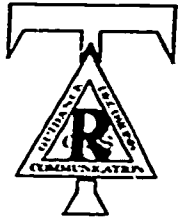

Title: UPDAT Page: 1

Chart: UPDATE Date: 7/9/69

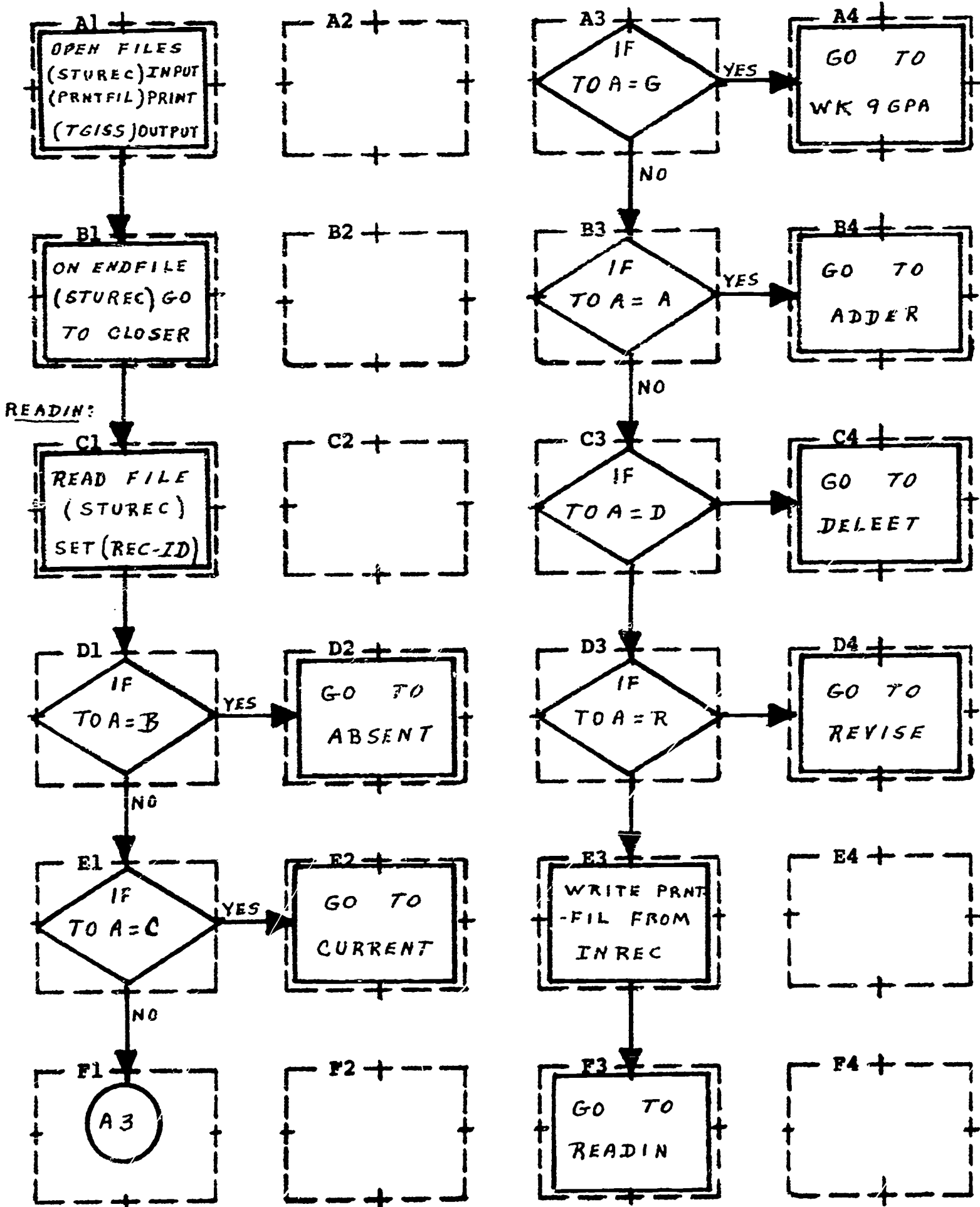

Bartlesville Public Schools - TGISS

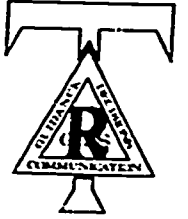

Title: DELETE

Page: 1

Chart: UPDATE

Date: 7/9/69

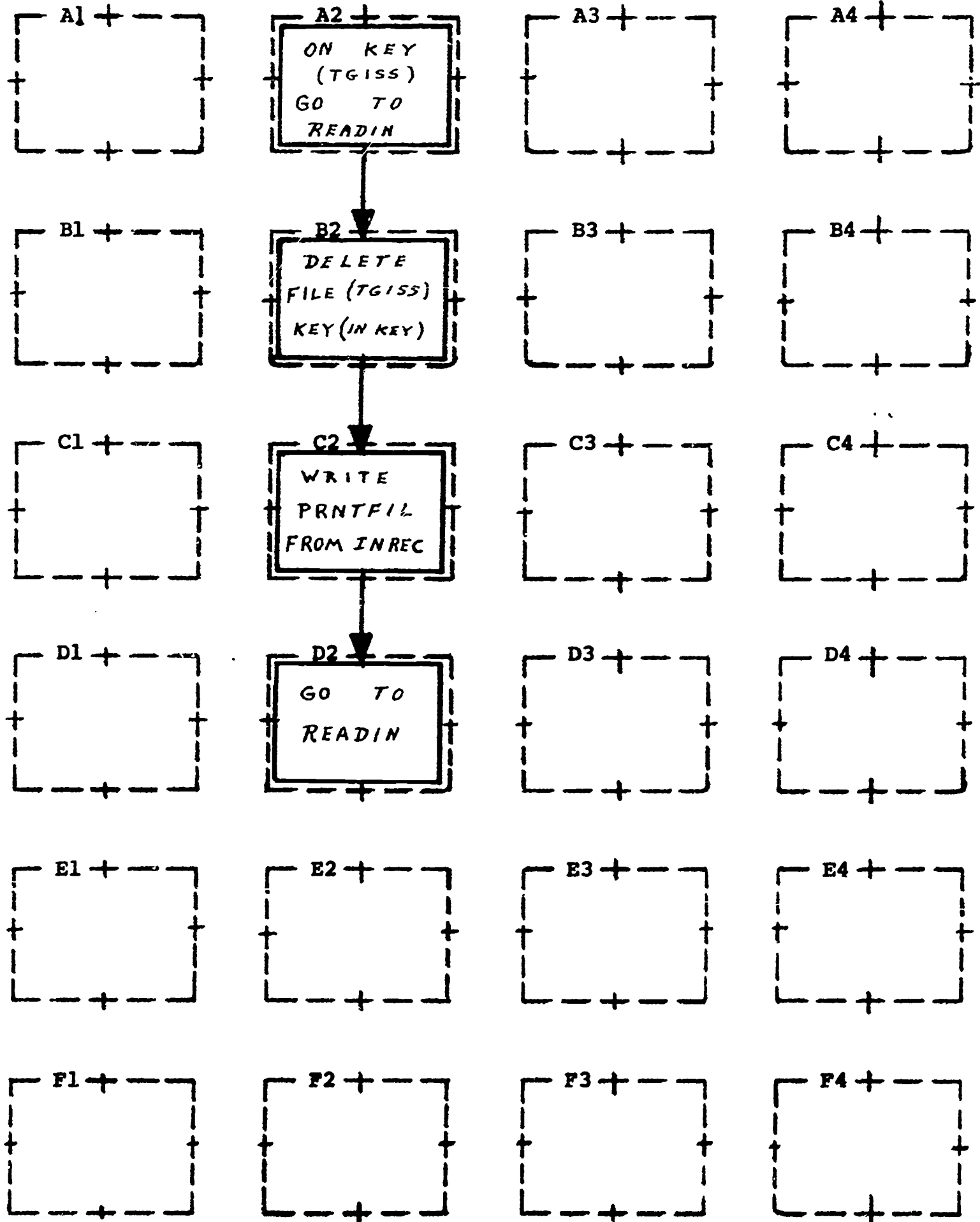

Bartlesville Public Schools - TGISS



Title: CURRENT

Page: 1

Chart: UPDATE

Date: 7/9/69

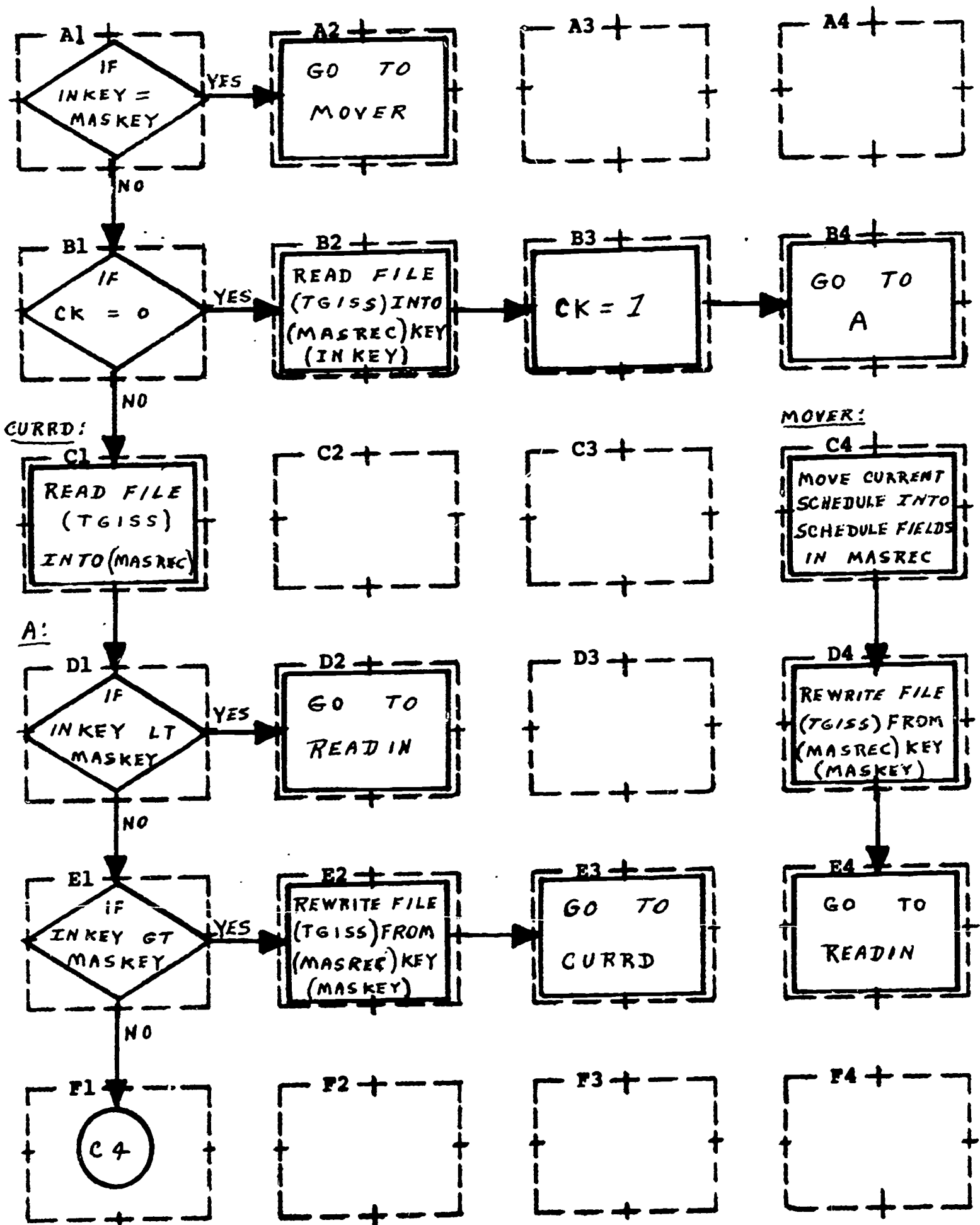

Bartlesville Public Schools - TGISS



Title: ADDER Page: 1

Chart: UPDAT Date: 7/10/69

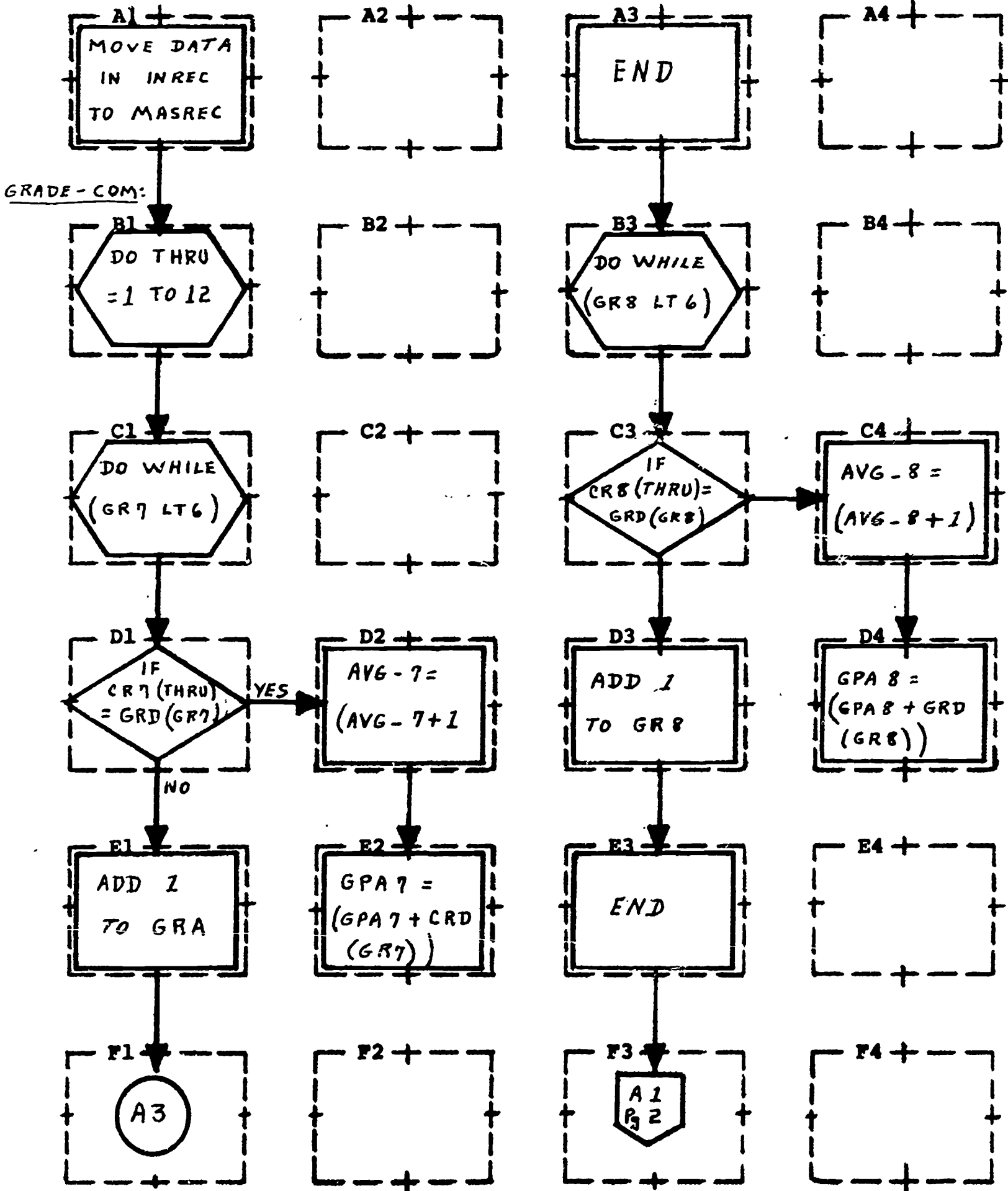

Bartlesville Public Schools - TGISS



Title: ADDER

Page: 2

Chart: UPDATE

Date: 10/6/69

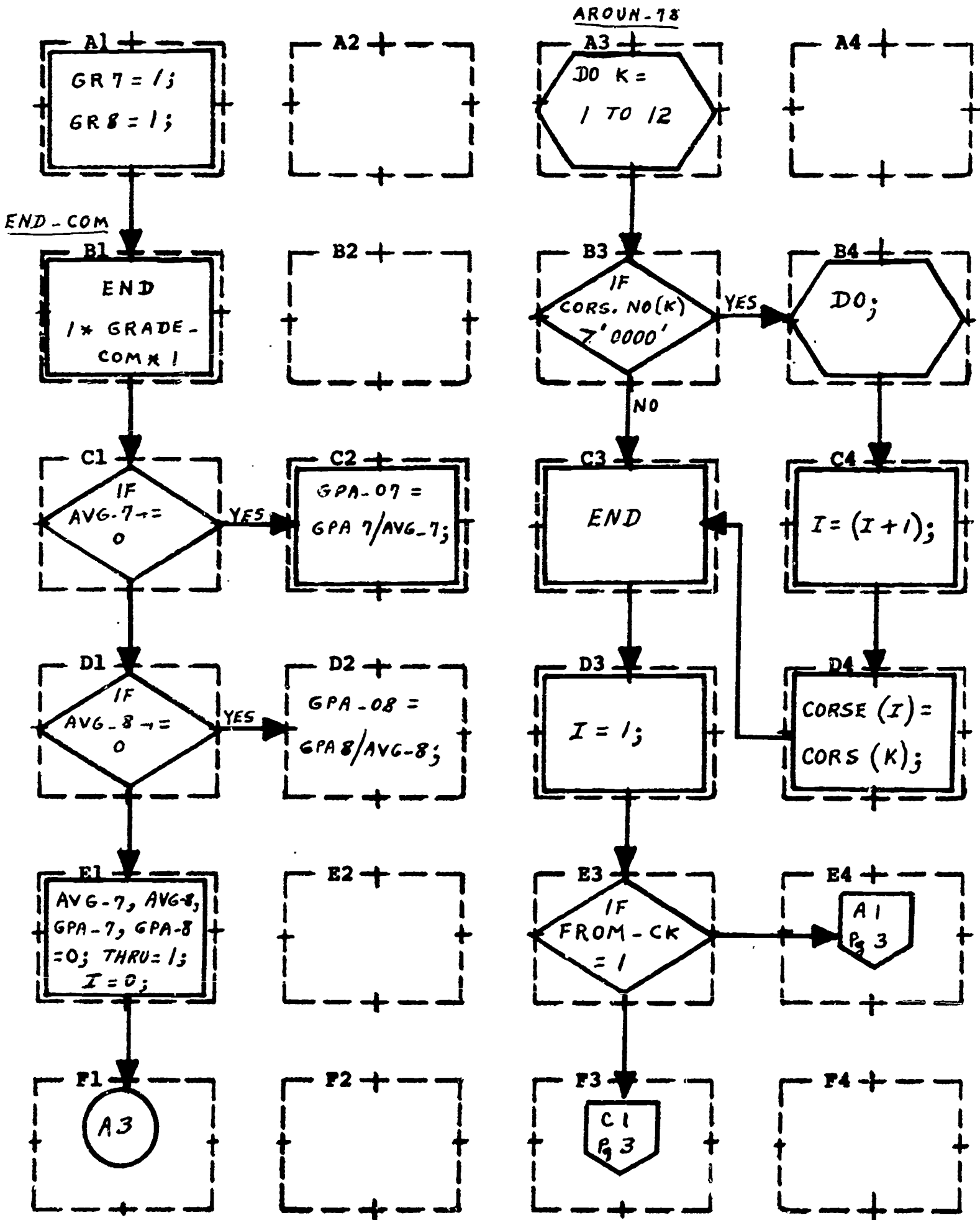



Title: ADDER Page: 3

Chart: UPDATE Date: 10/6/69

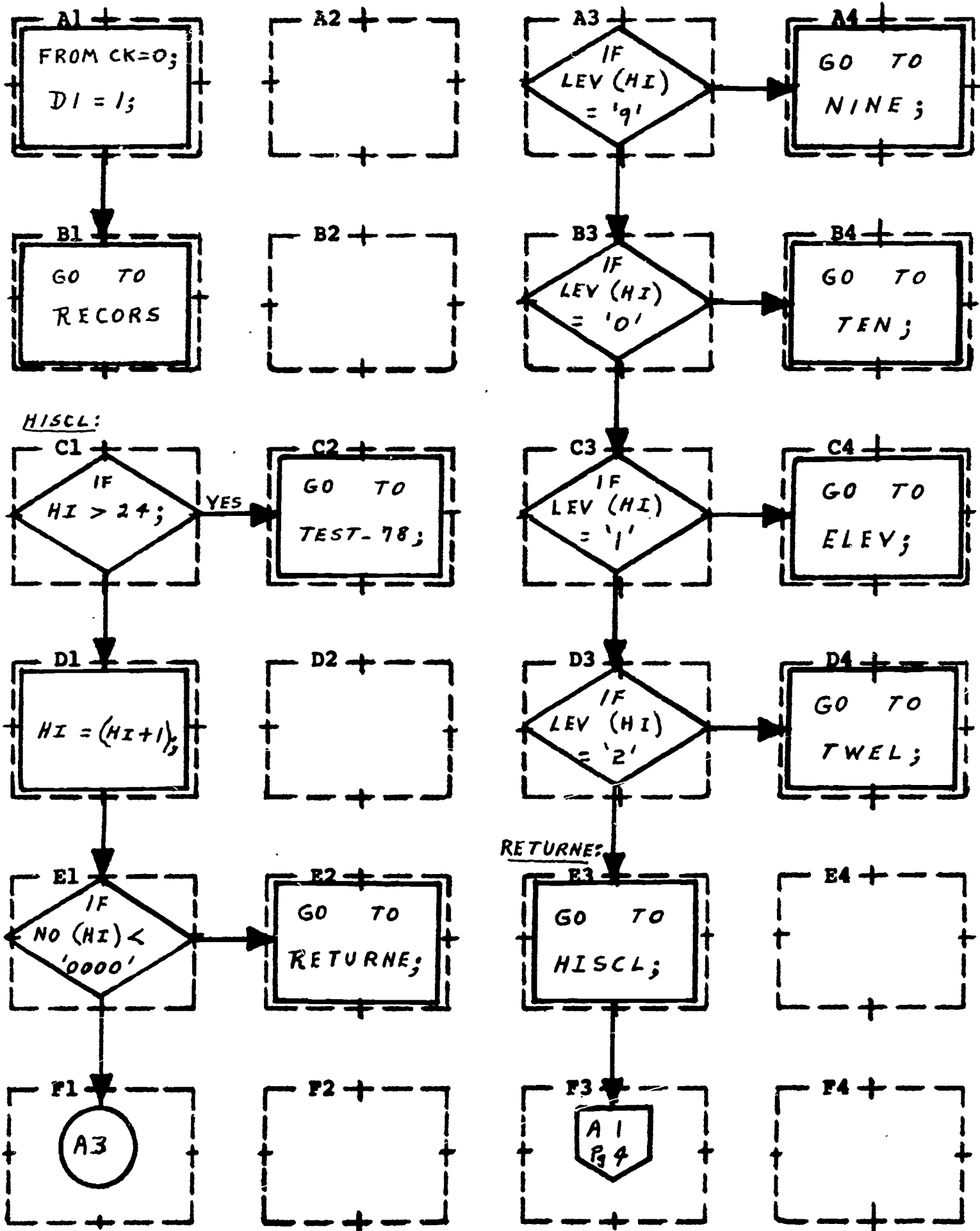

Bartlesville Public Schools - TGISS



Title: ADDER

Page: 4

Chart: UPDATE

Date: 10/6/69

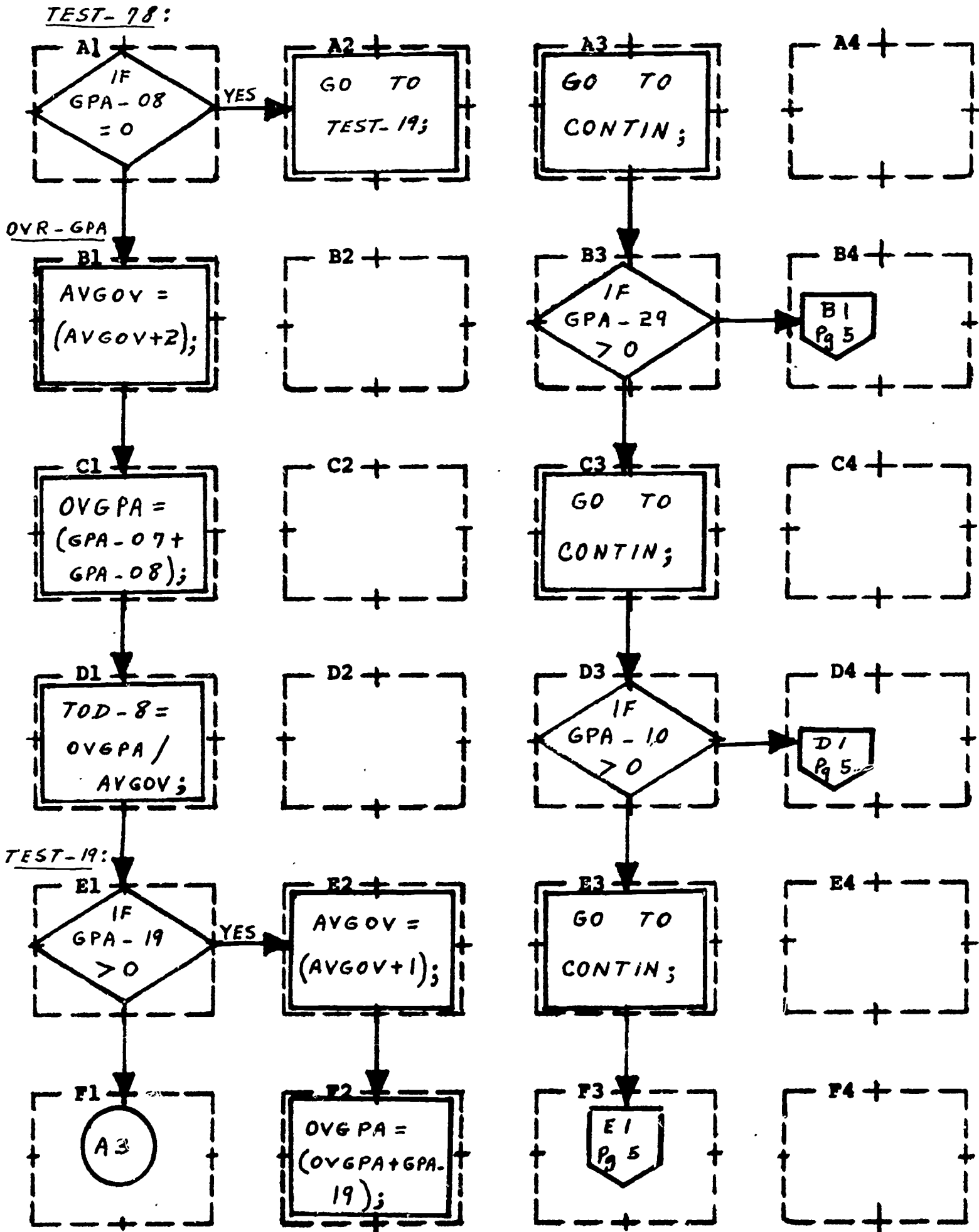

Bartlesville Public Schools - TGISS



Title: ADDER

Page: 5

Chart: UPDATE

Date: 10/6/69

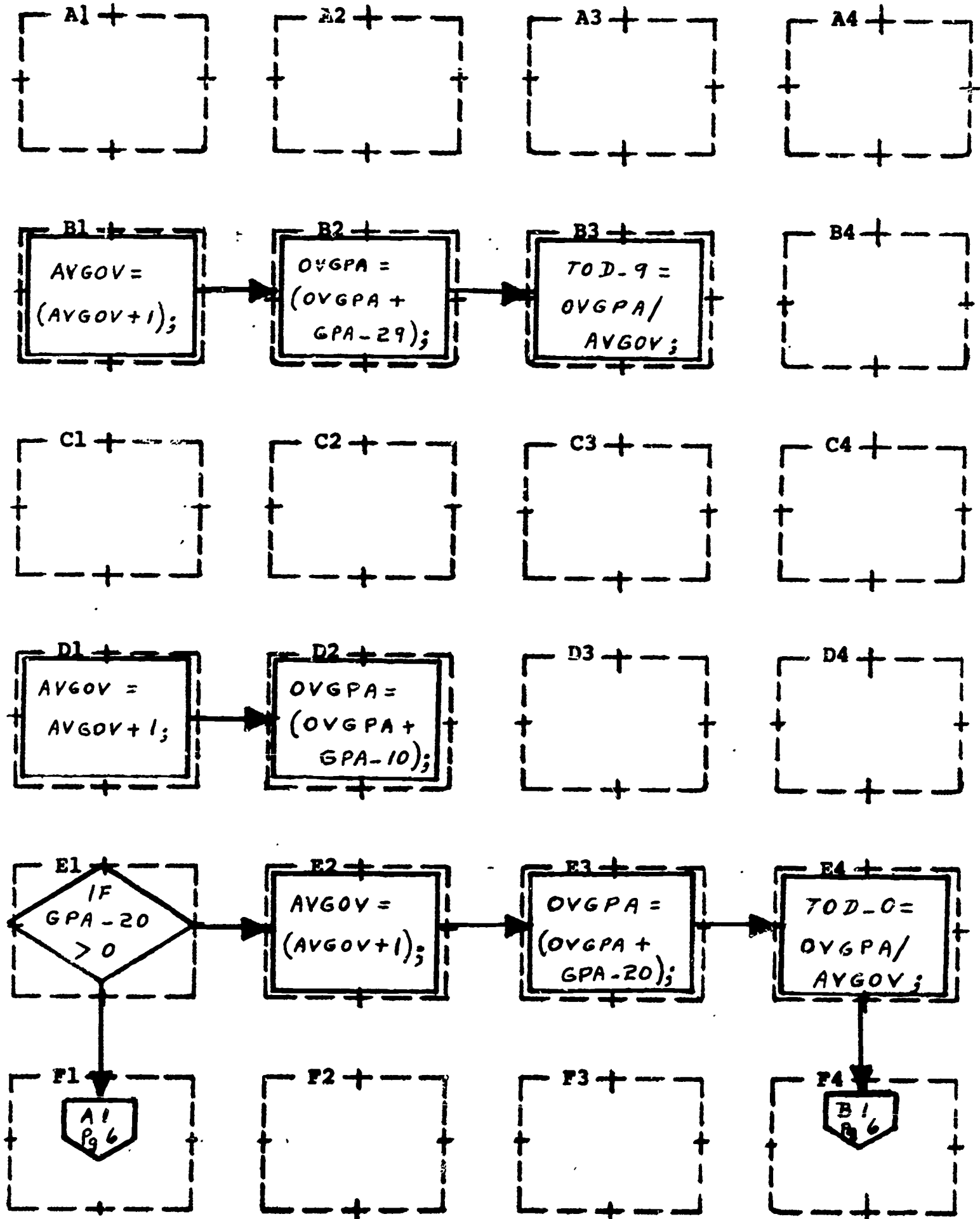

Bartlesville Public Schools - TGISS



Title: ADDER

Page: 6

Chart: UPDATE

Date: 10/6/69

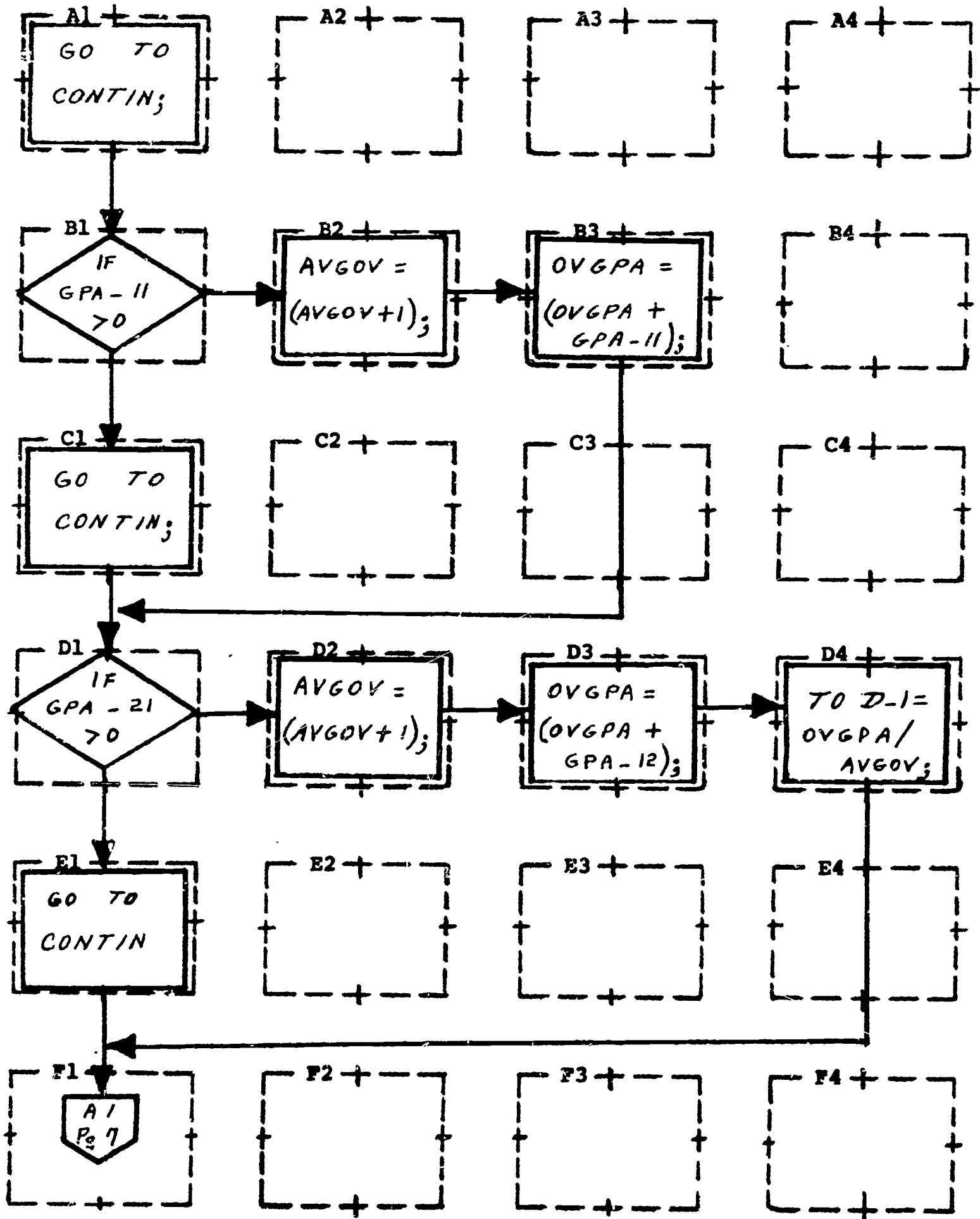

Bartlesville Public Schools - TGISS



Title: ADDER

Page: 7

Chart: UPDATE

Date: 10/6/69

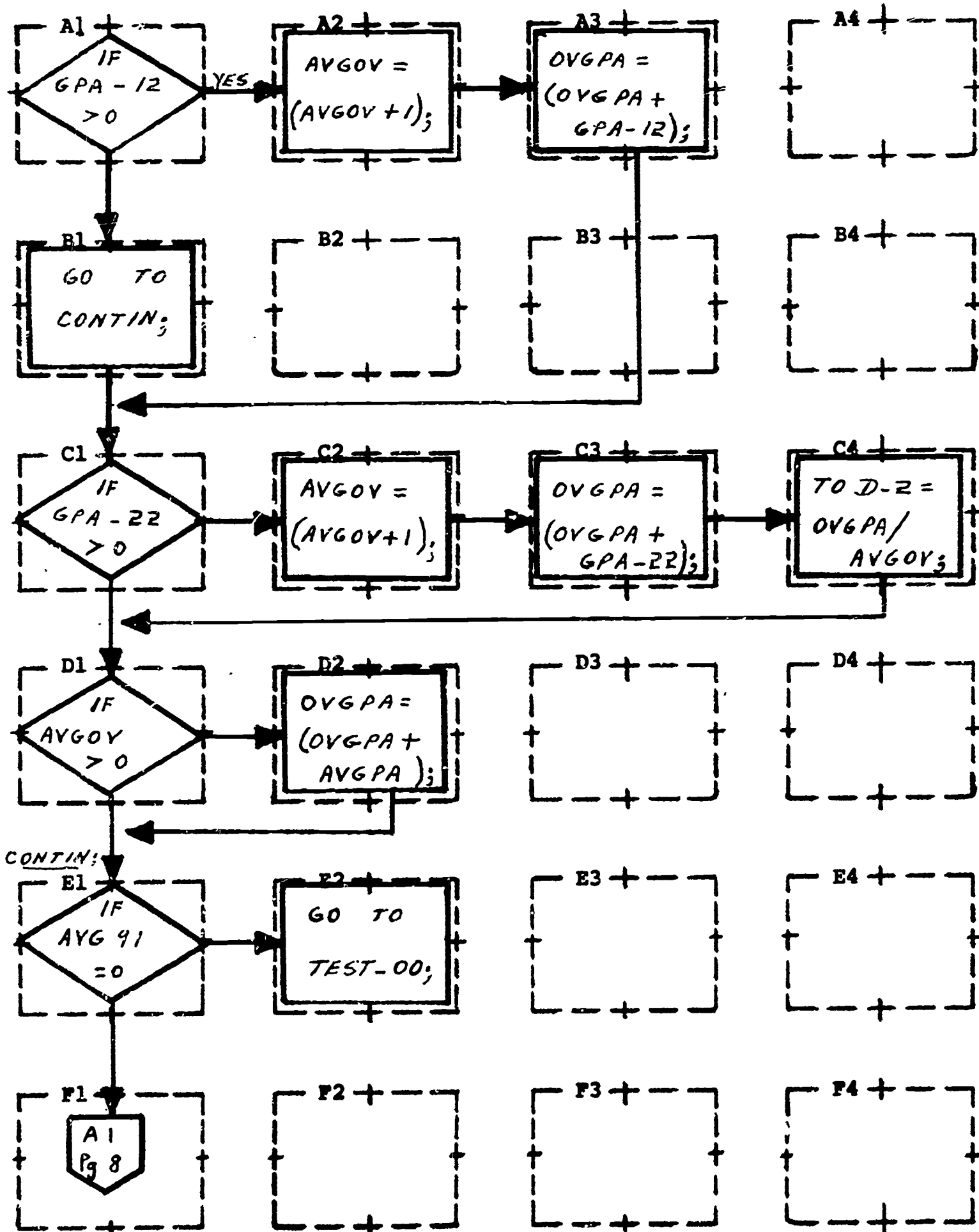



Title: ADDER

Page: 8

Chart: UPDATE

Date: 10/6/69

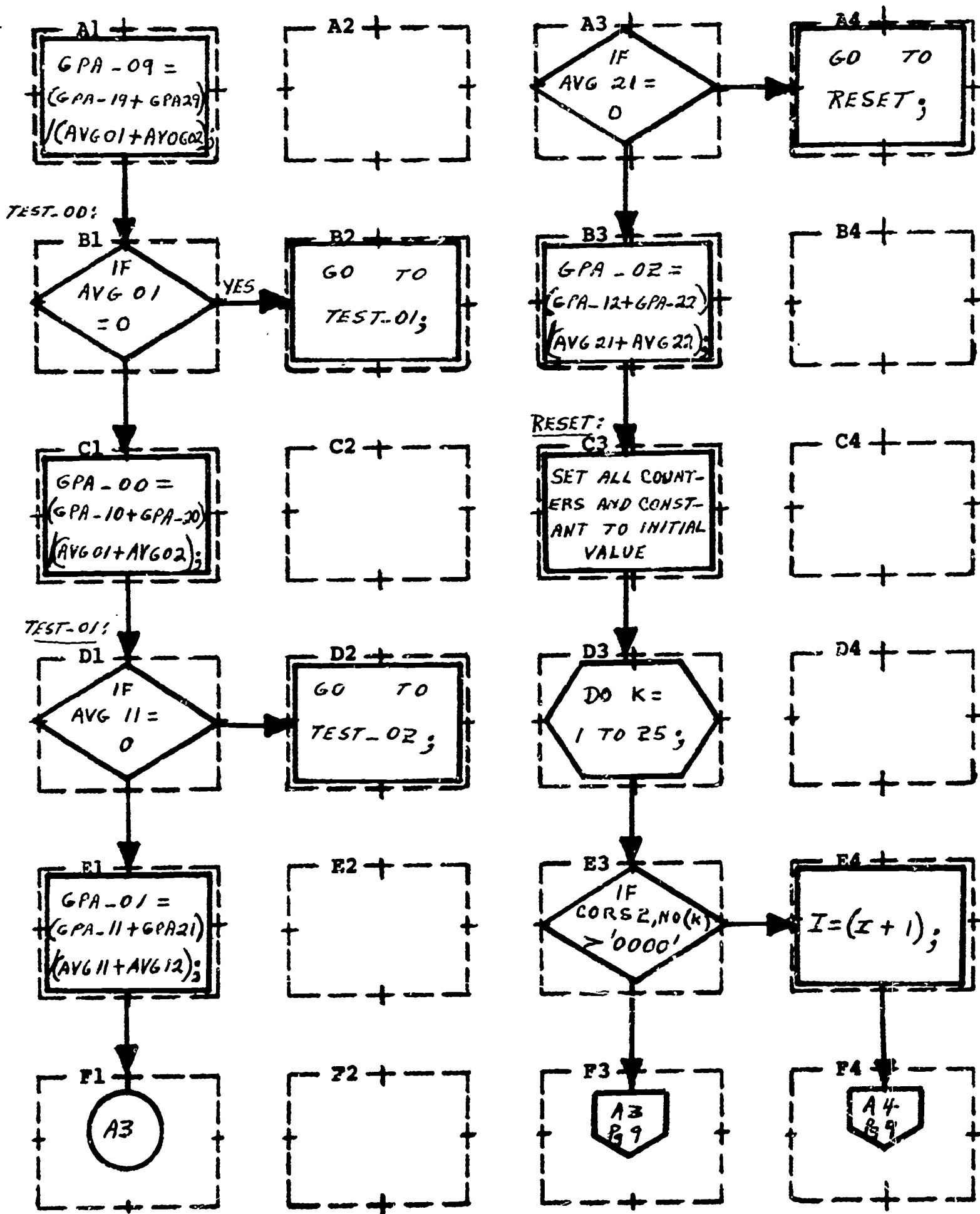

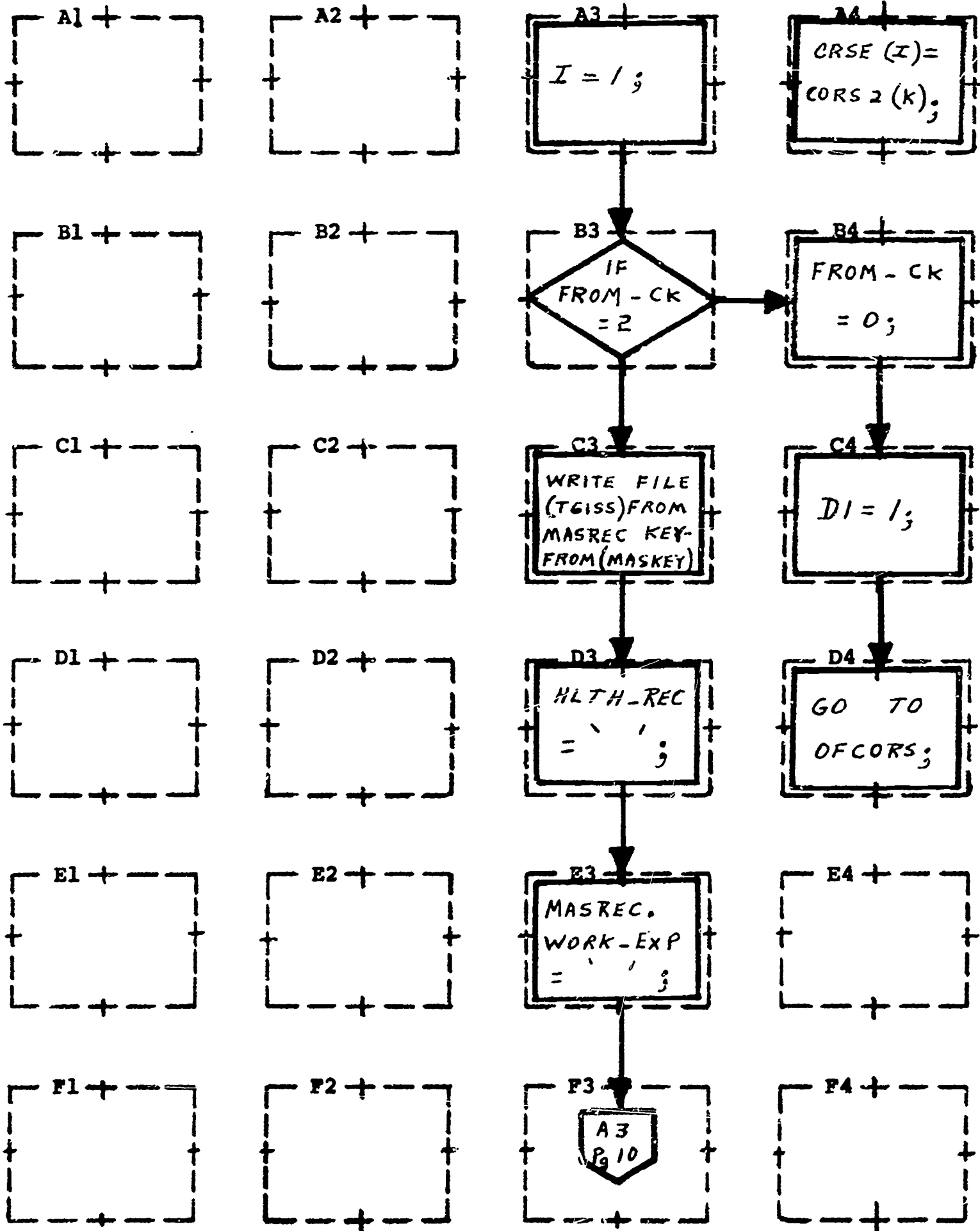



Title: ADDER Page: 10

Chart: UPDATE Date: 10/6/69

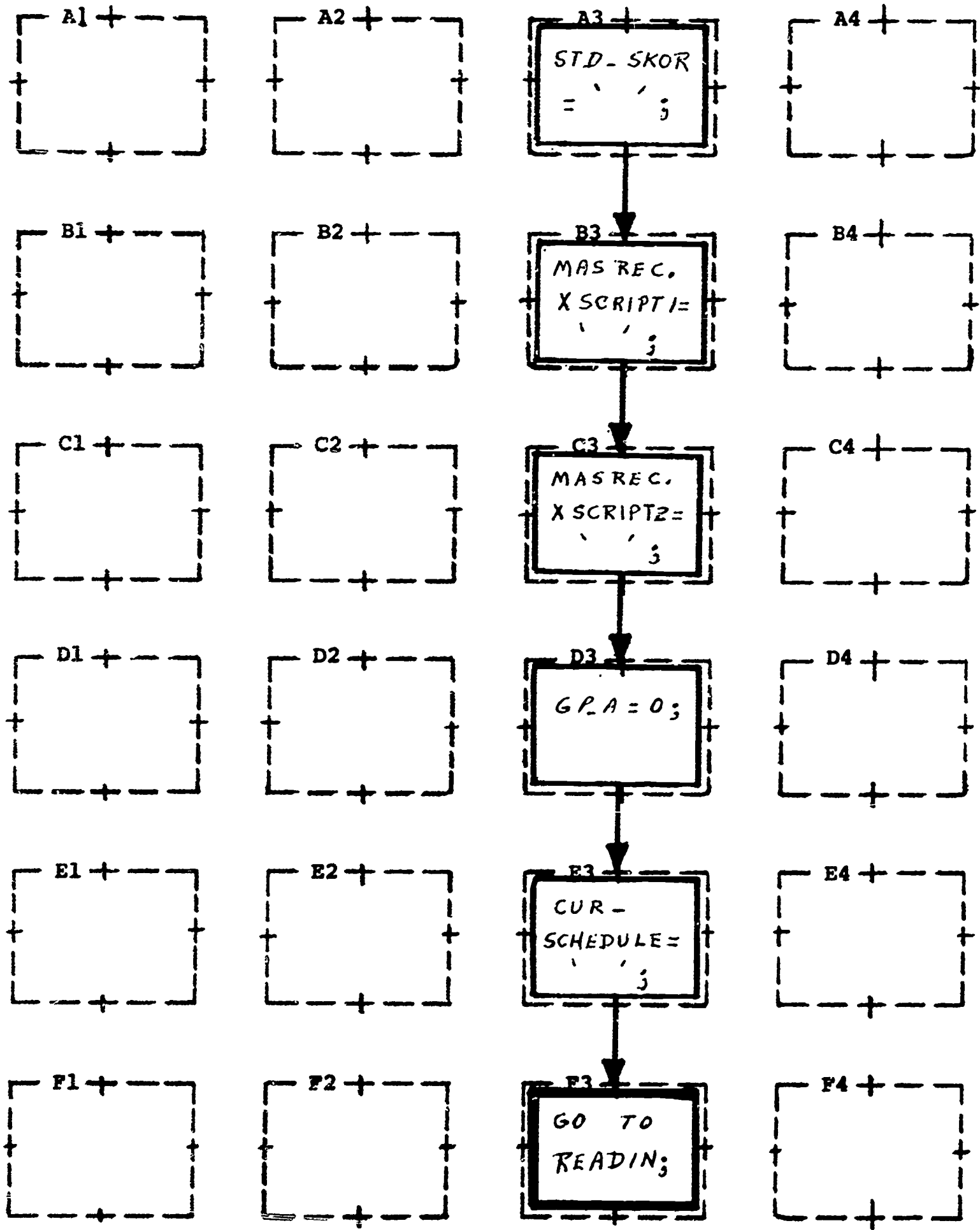

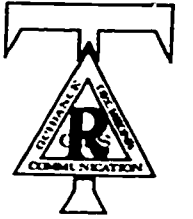

Title: NINE Page: 1

Chart: UPDATE Date: 10/6/69

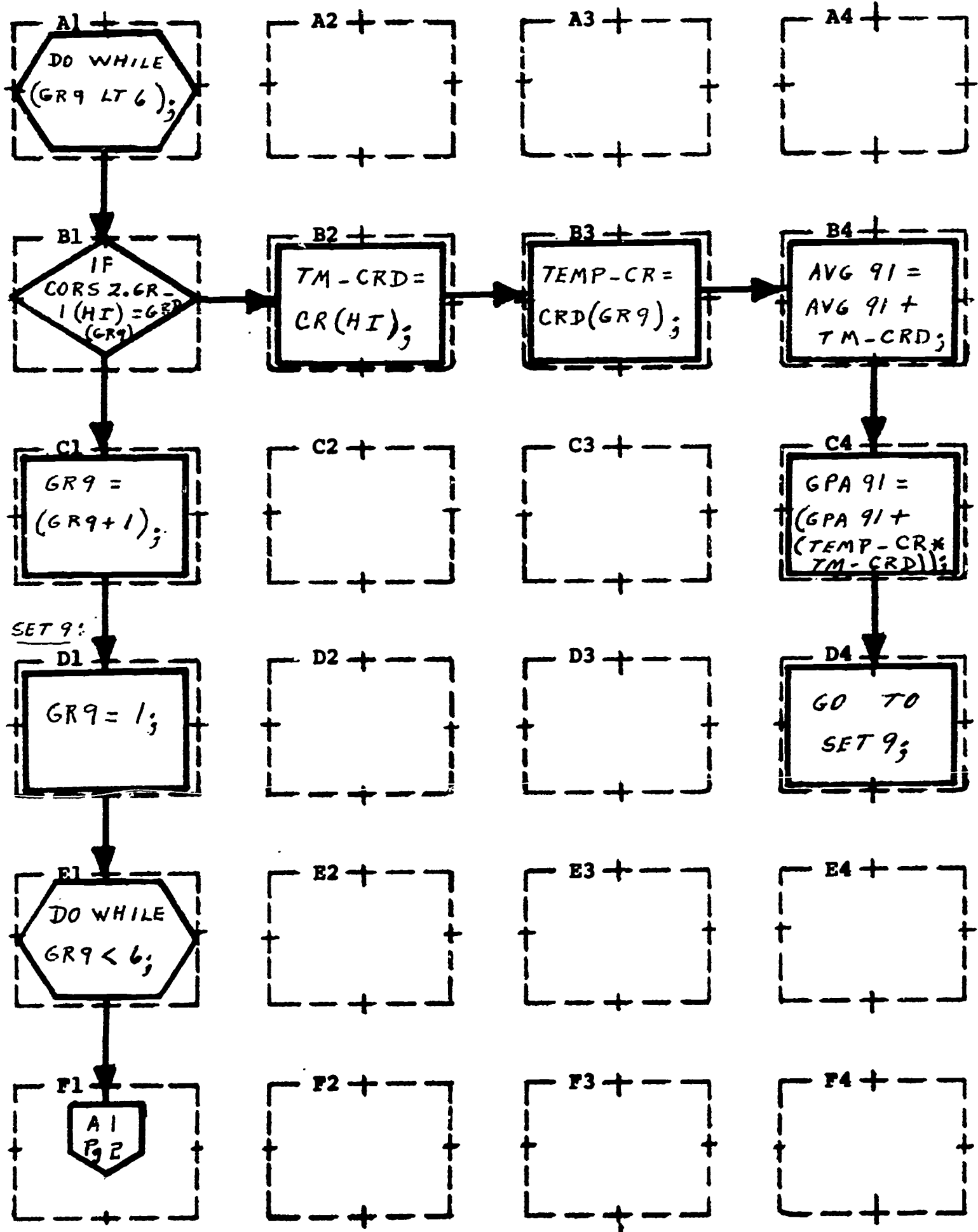



Title: NINE

Page: 2

Chart: UPDATE

Date: 10/6/69

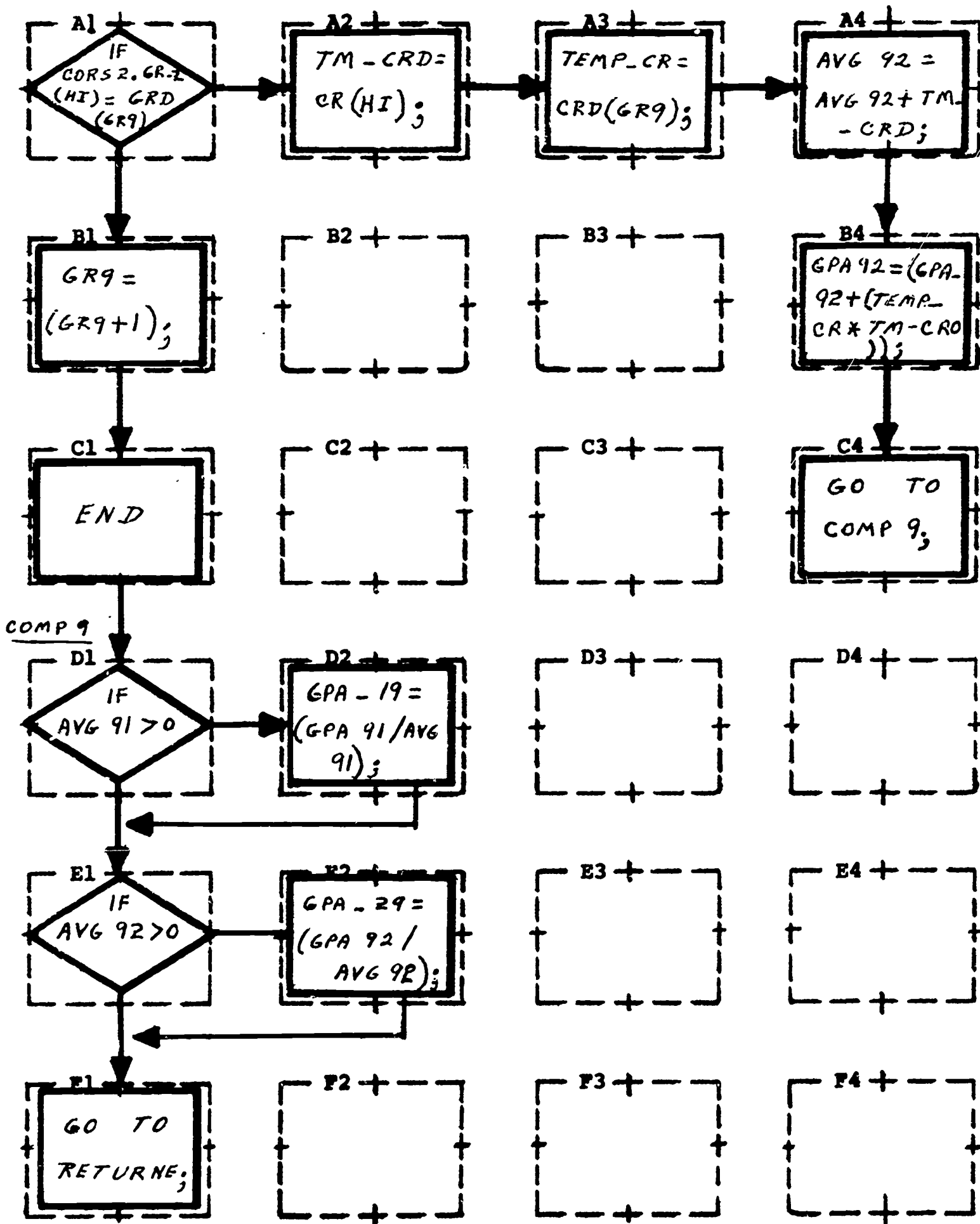

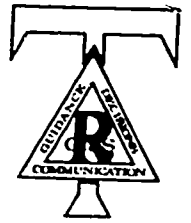

Title: TEN

Page: 1

Chart: UPDATE

Date: 10/6/69

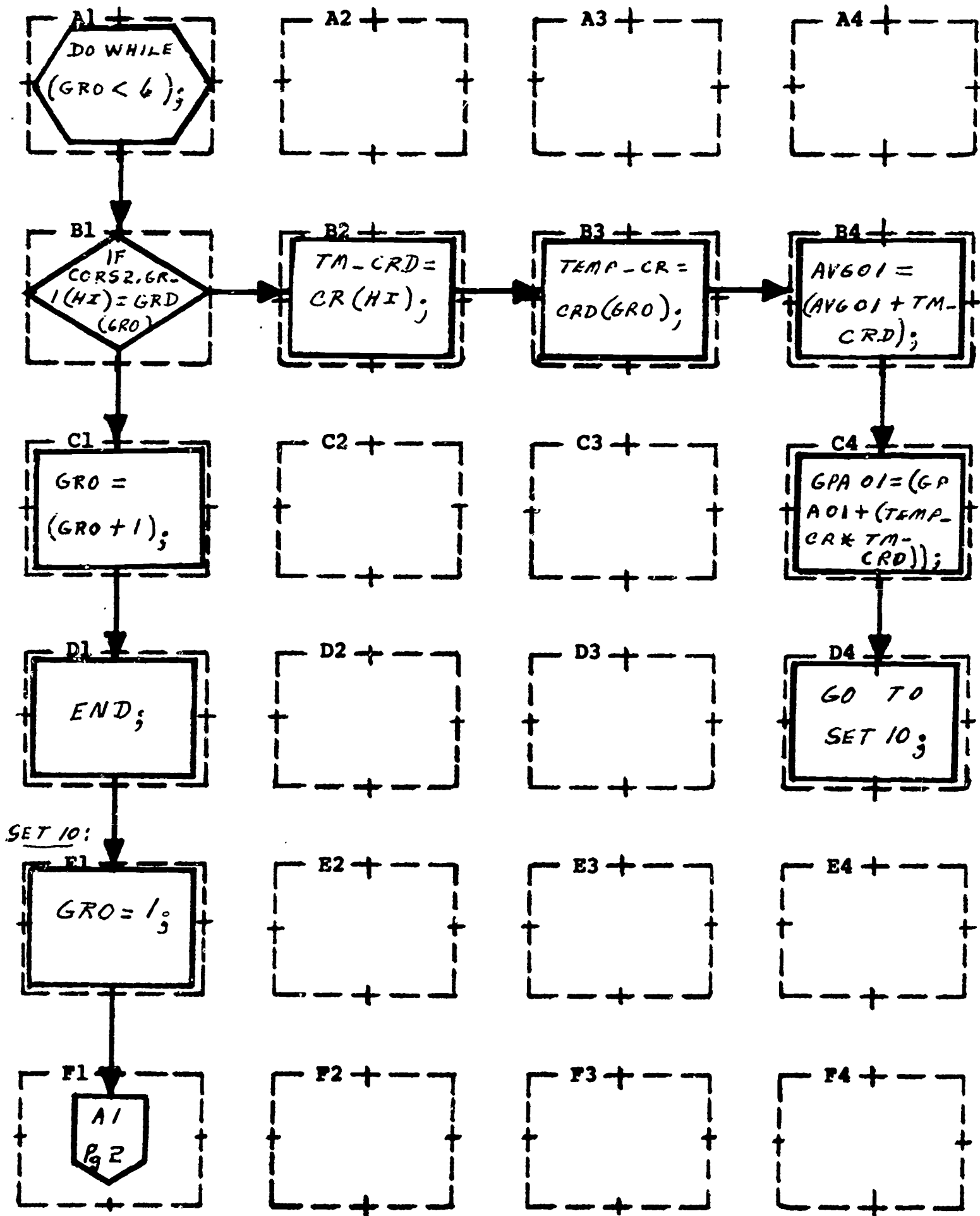

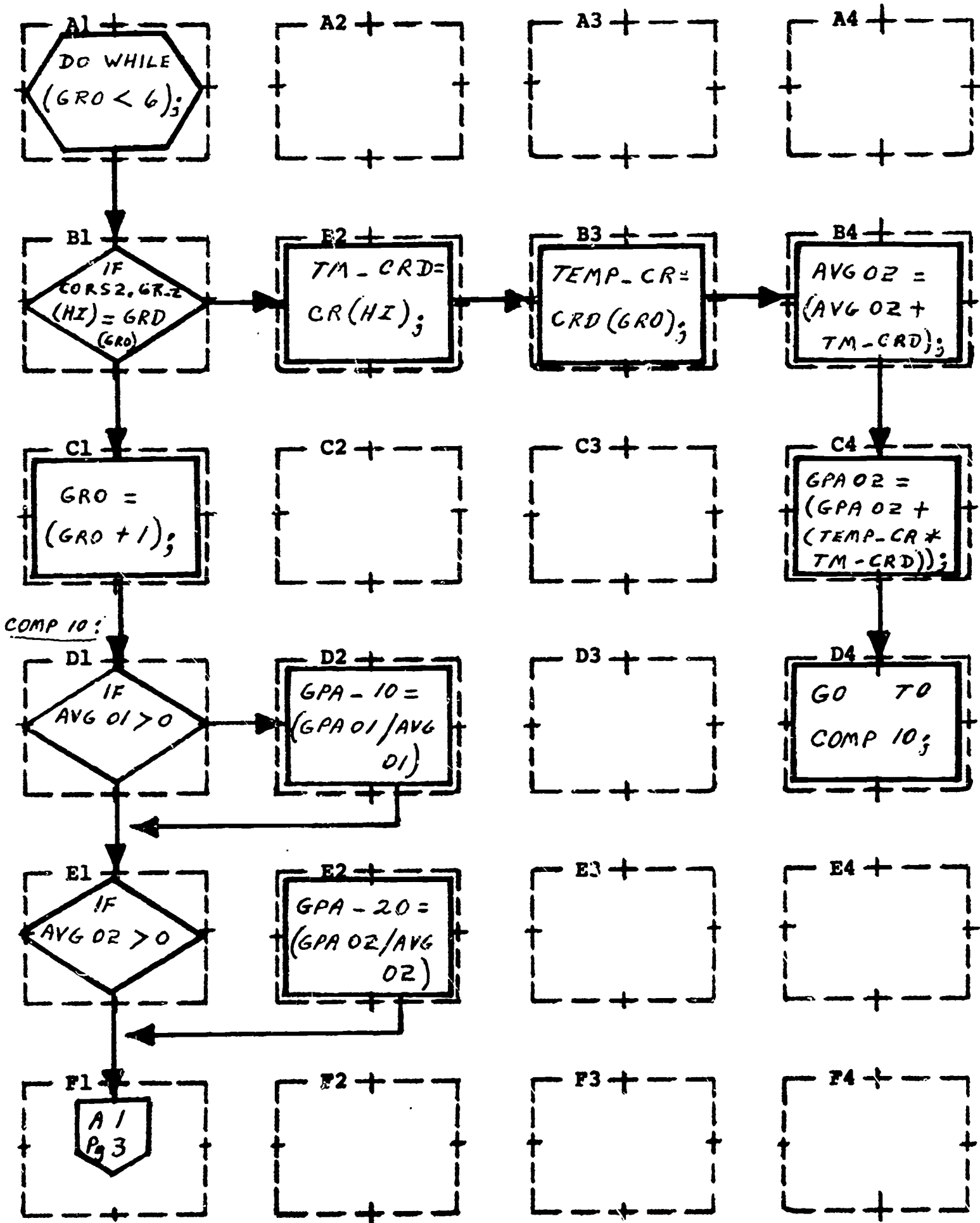
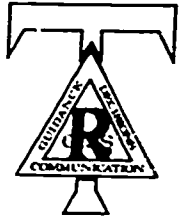

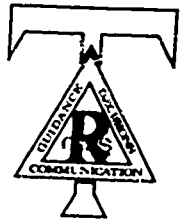

Title: TEN Page: 3

Chart: UPDATE Date: 10/6/69

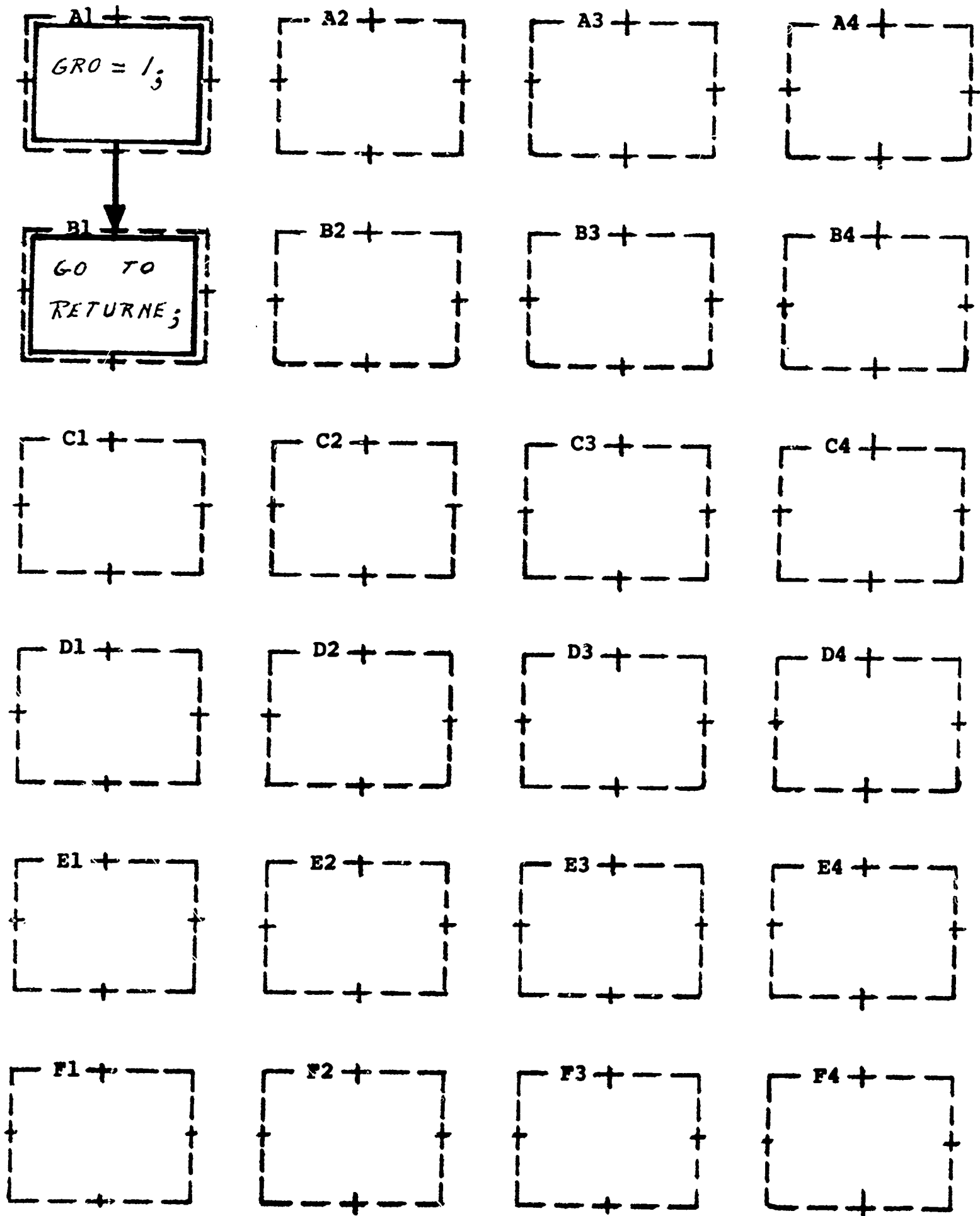



Title: ELEV Page: 1

Chart: UPDATE Date: 10/6/69

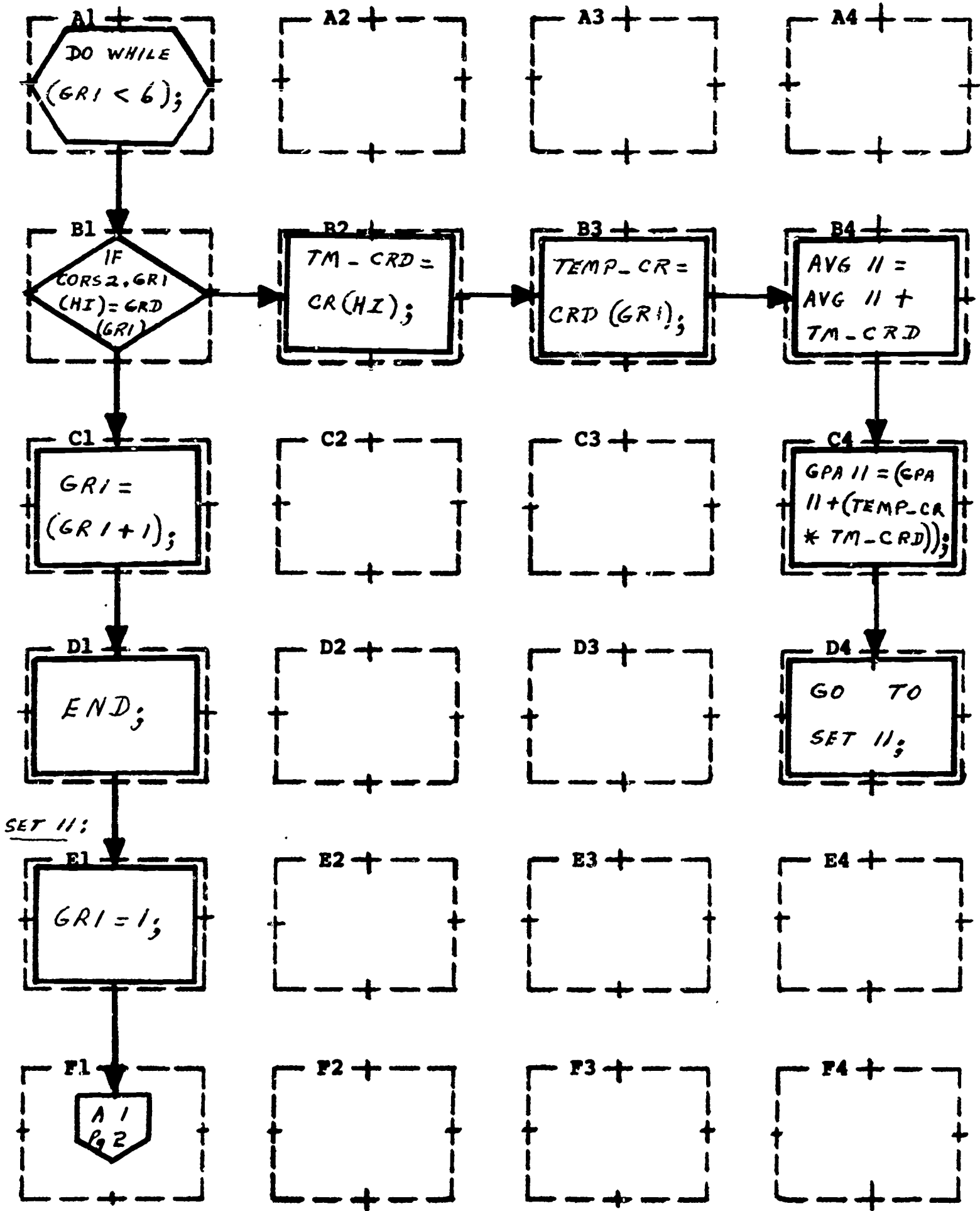

Bartlesville Public Schools - TGISS



Title: ELEV

Page: 2

Chart: UPDATE

Date: 10/6/69

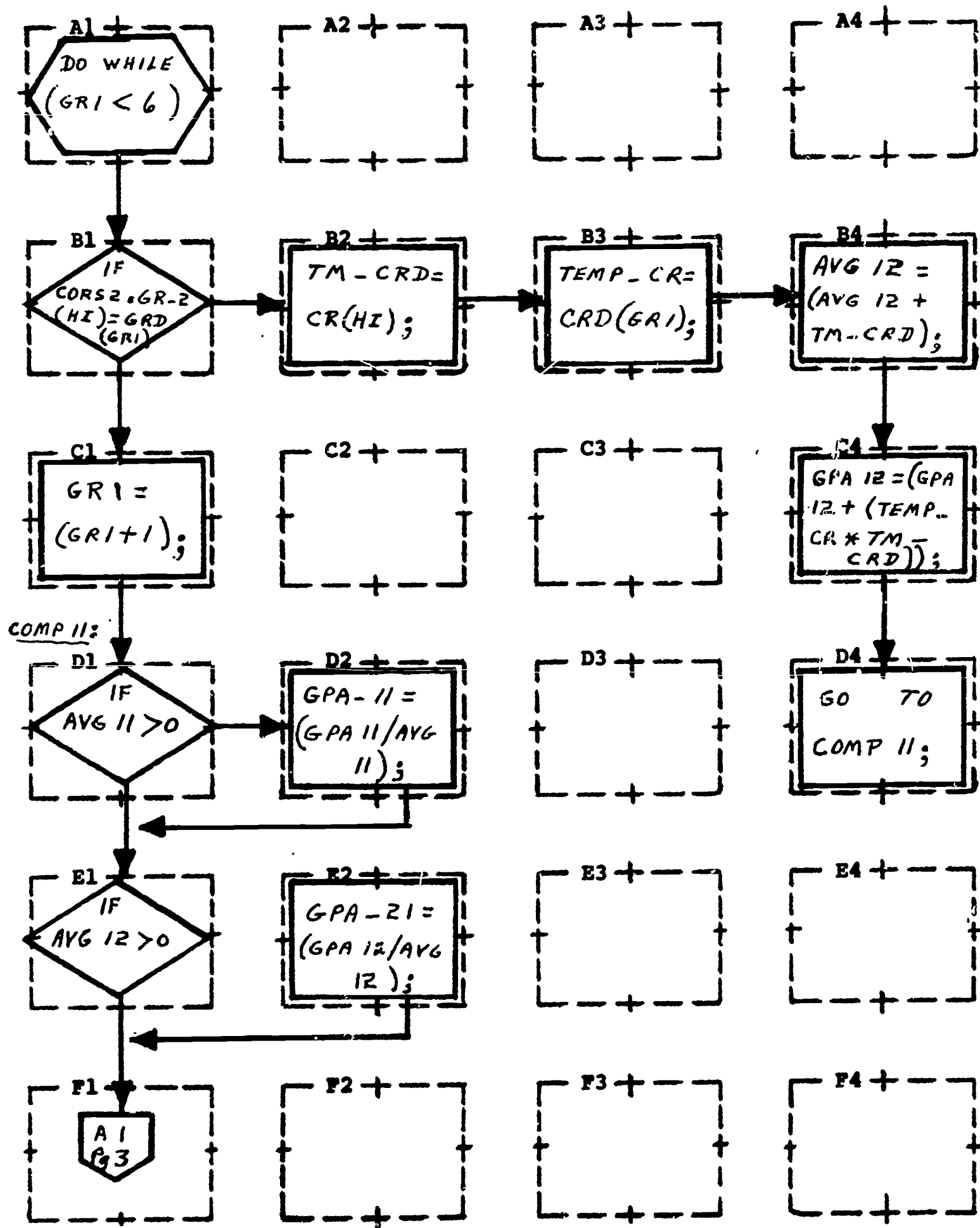

Bartlesville Public Schools - TGISS

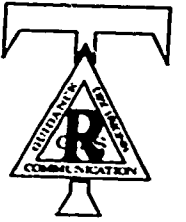

Title: ELEV Page: 3

Chart: UPDATE Date: 10/6/69

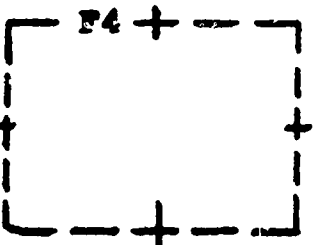
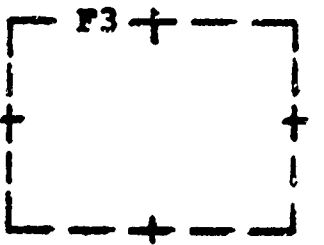
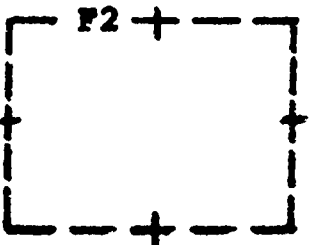
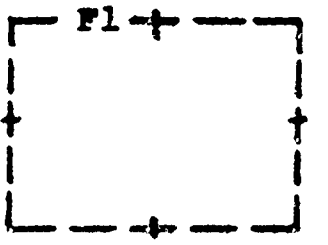
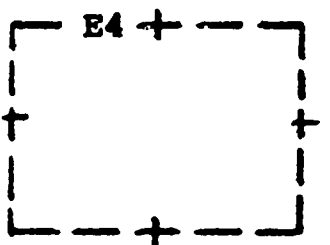
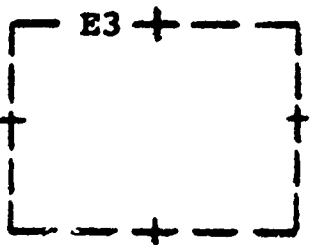
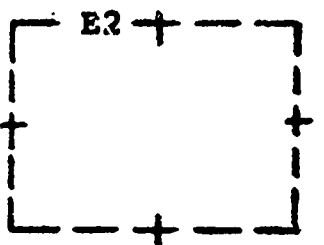
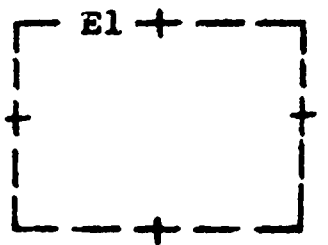
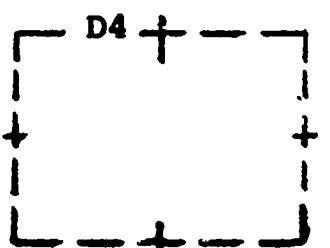
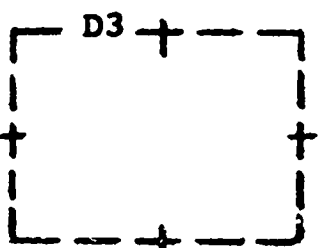
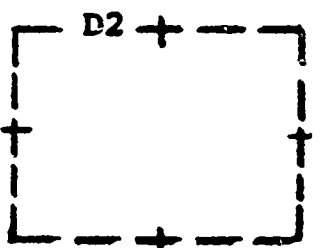
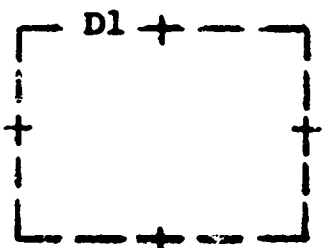
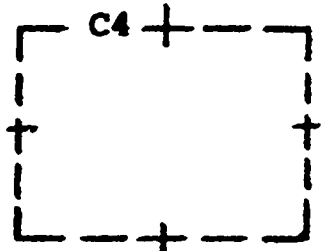
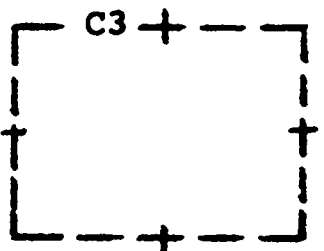
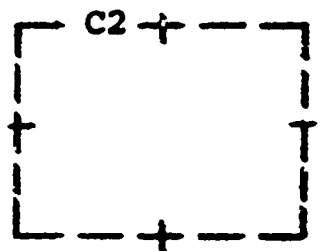
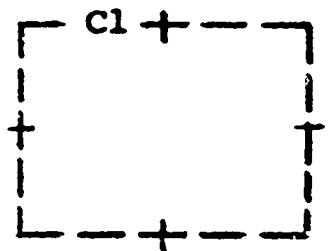
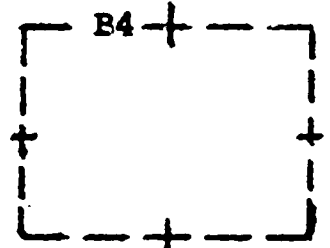
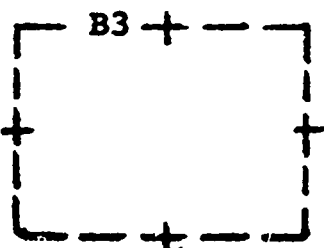
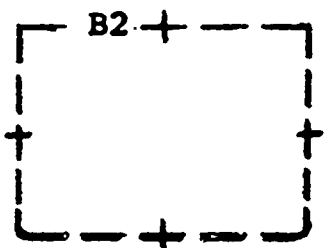
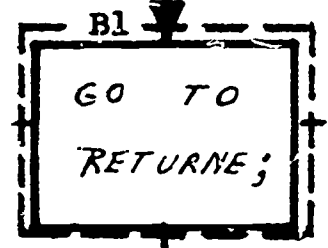
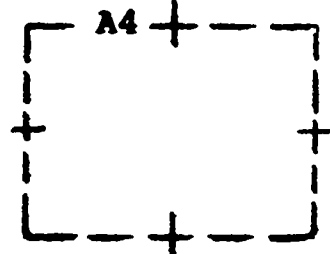
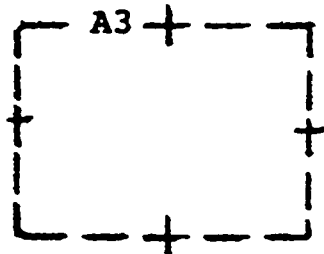
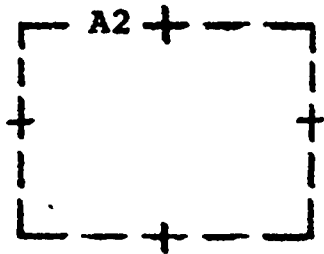
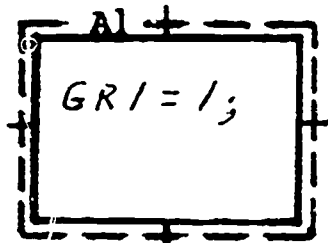

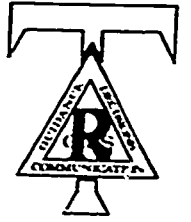

Title: TWEL Page: 1

Chart: UPDATE Date: 10/6/69

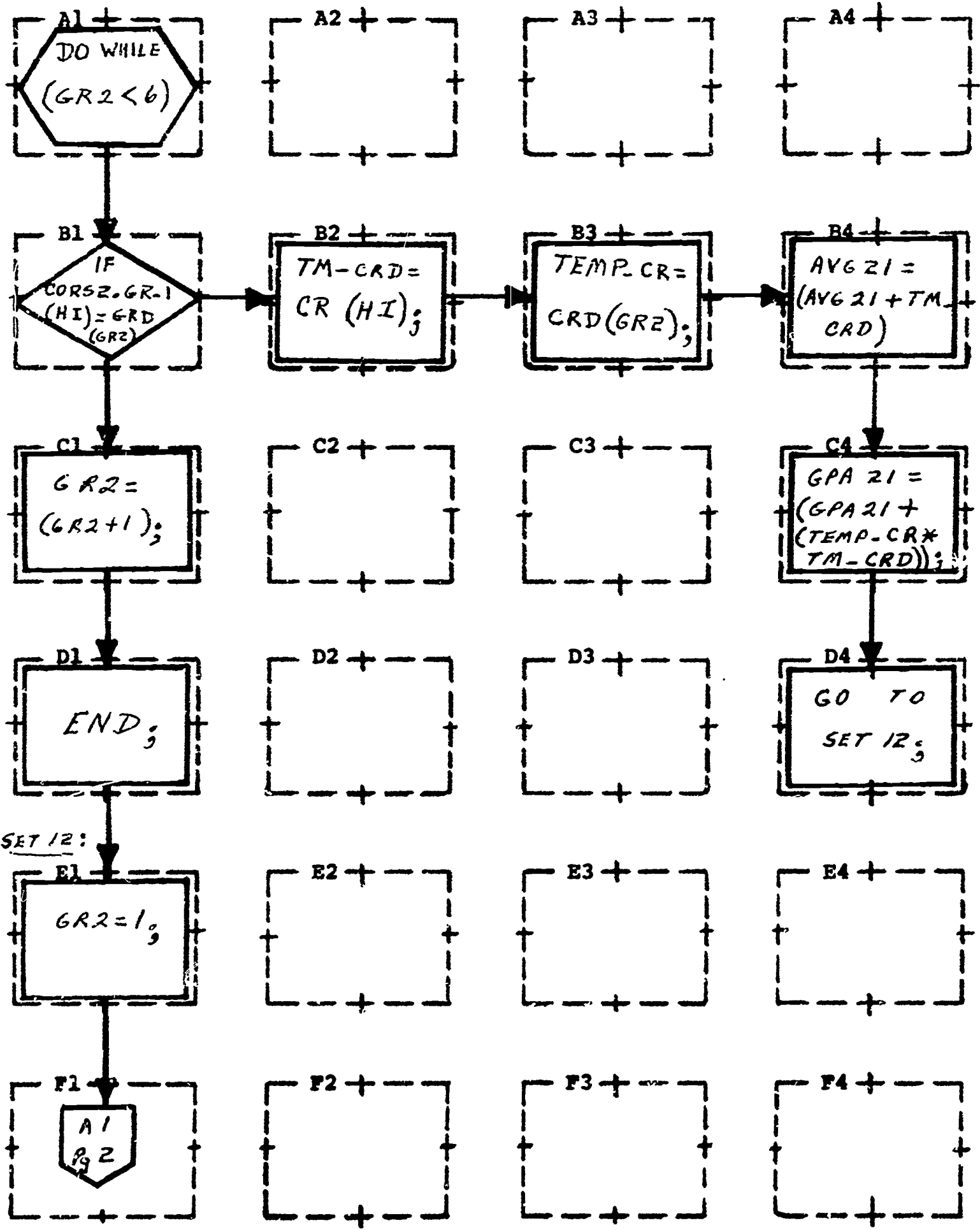

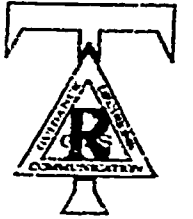

Title: TWEL

Page: 2

Chart: UPDATE

Date: 10/6/69

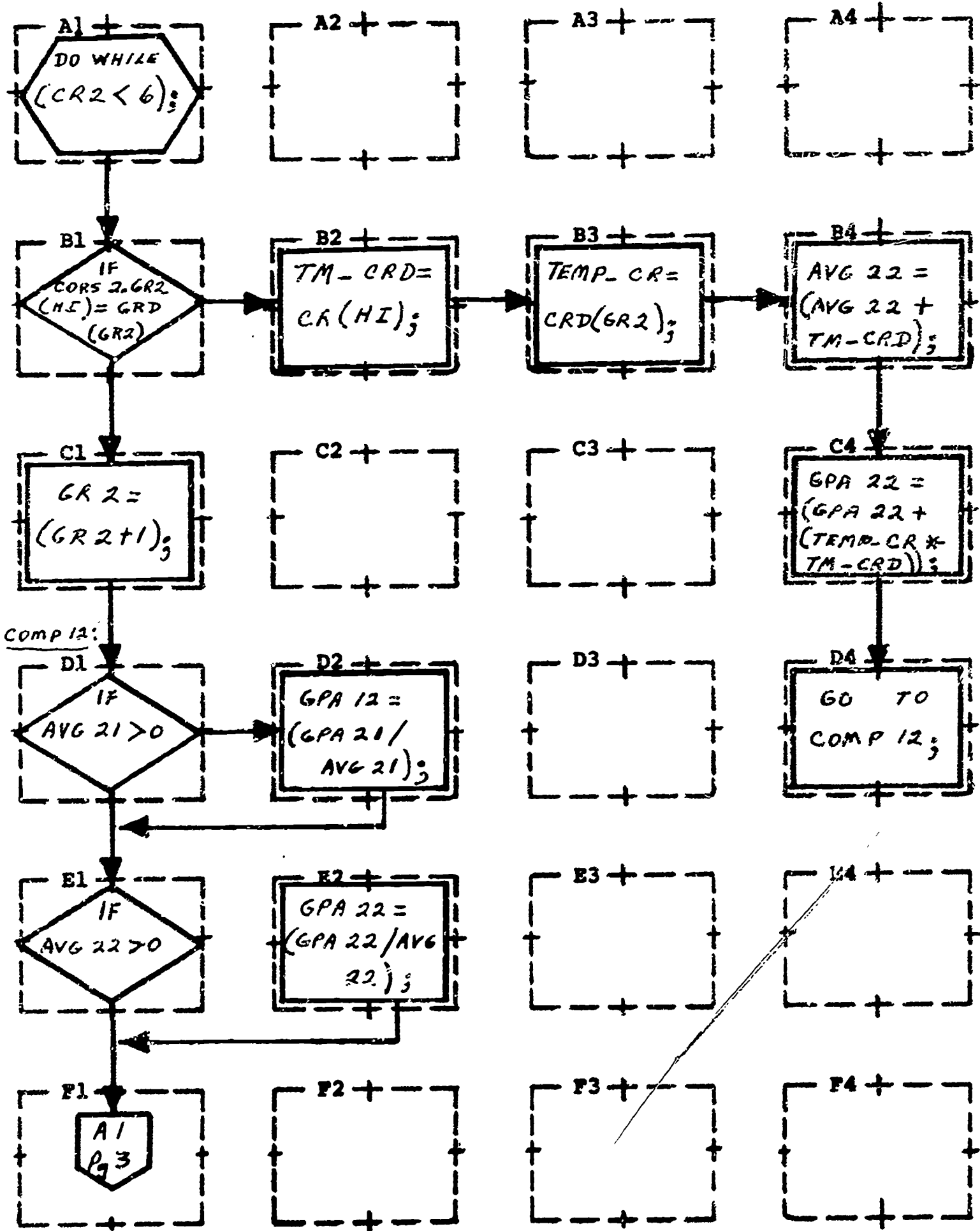



Title: TWEL Page: 3

Chart: UPDATE Date: 10/6/69

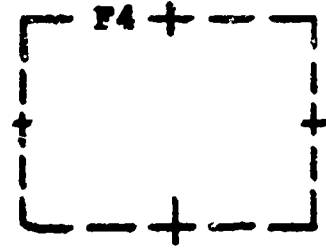
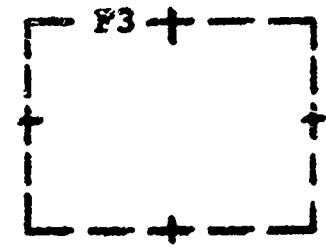
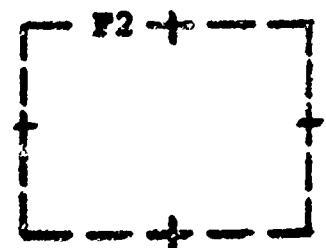
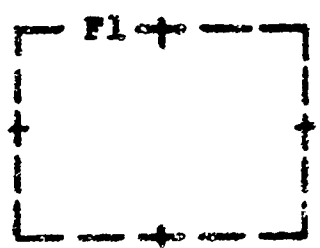
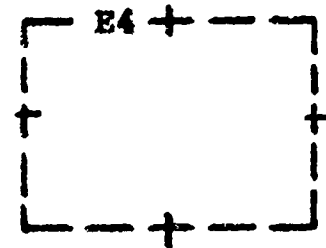
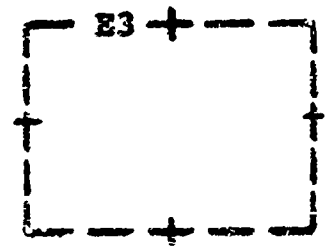
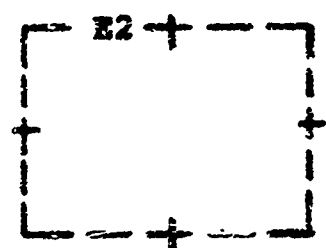
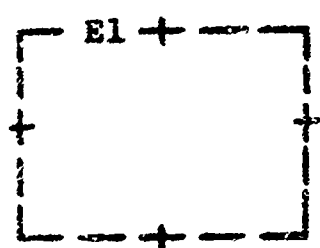
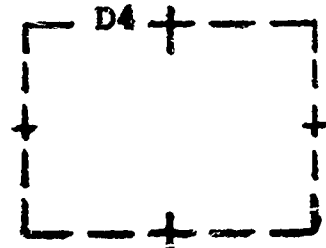
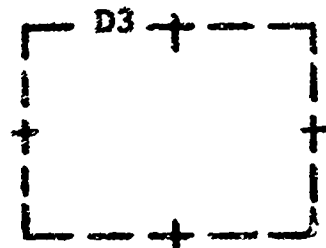
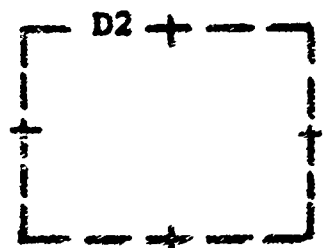
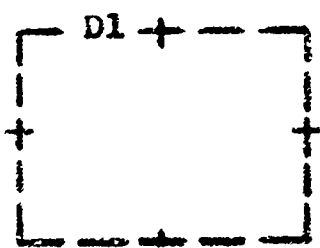
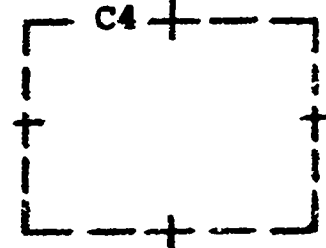
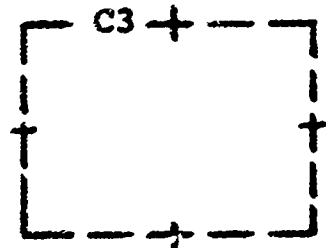
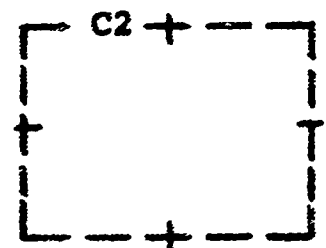
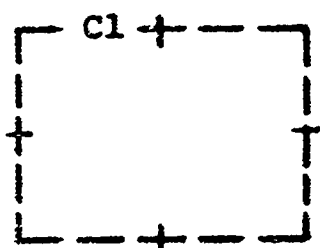
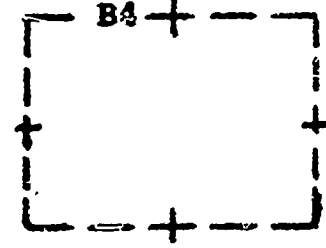
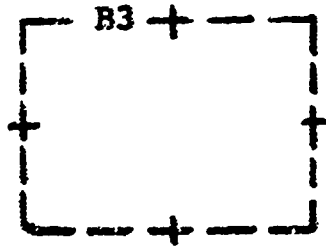
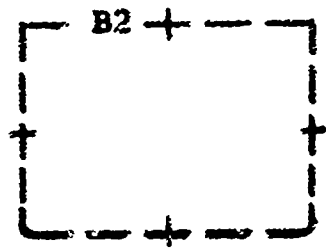
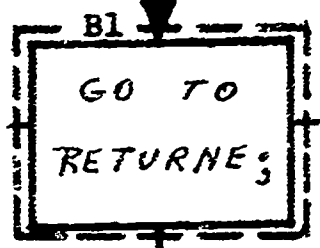
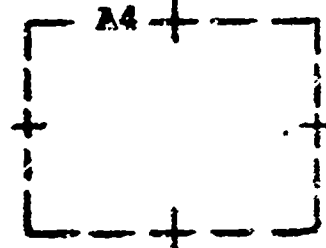
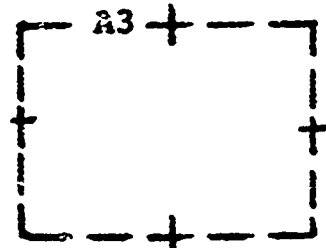
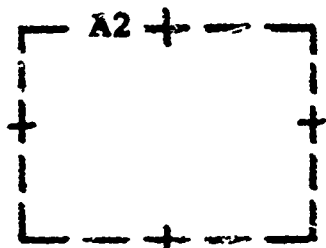
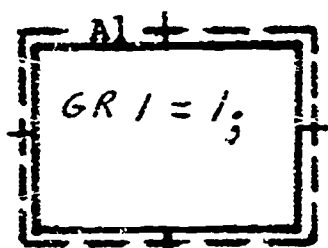

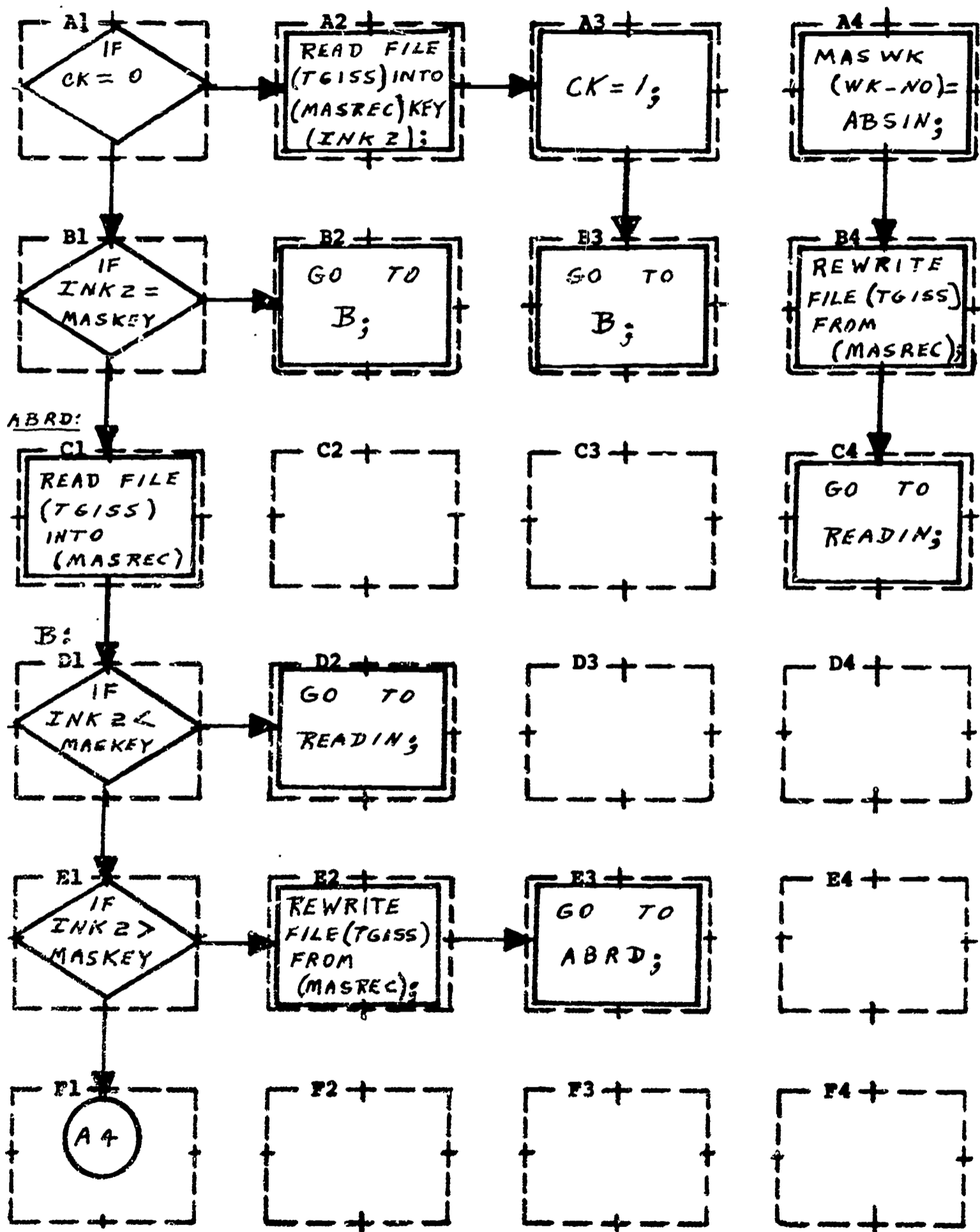

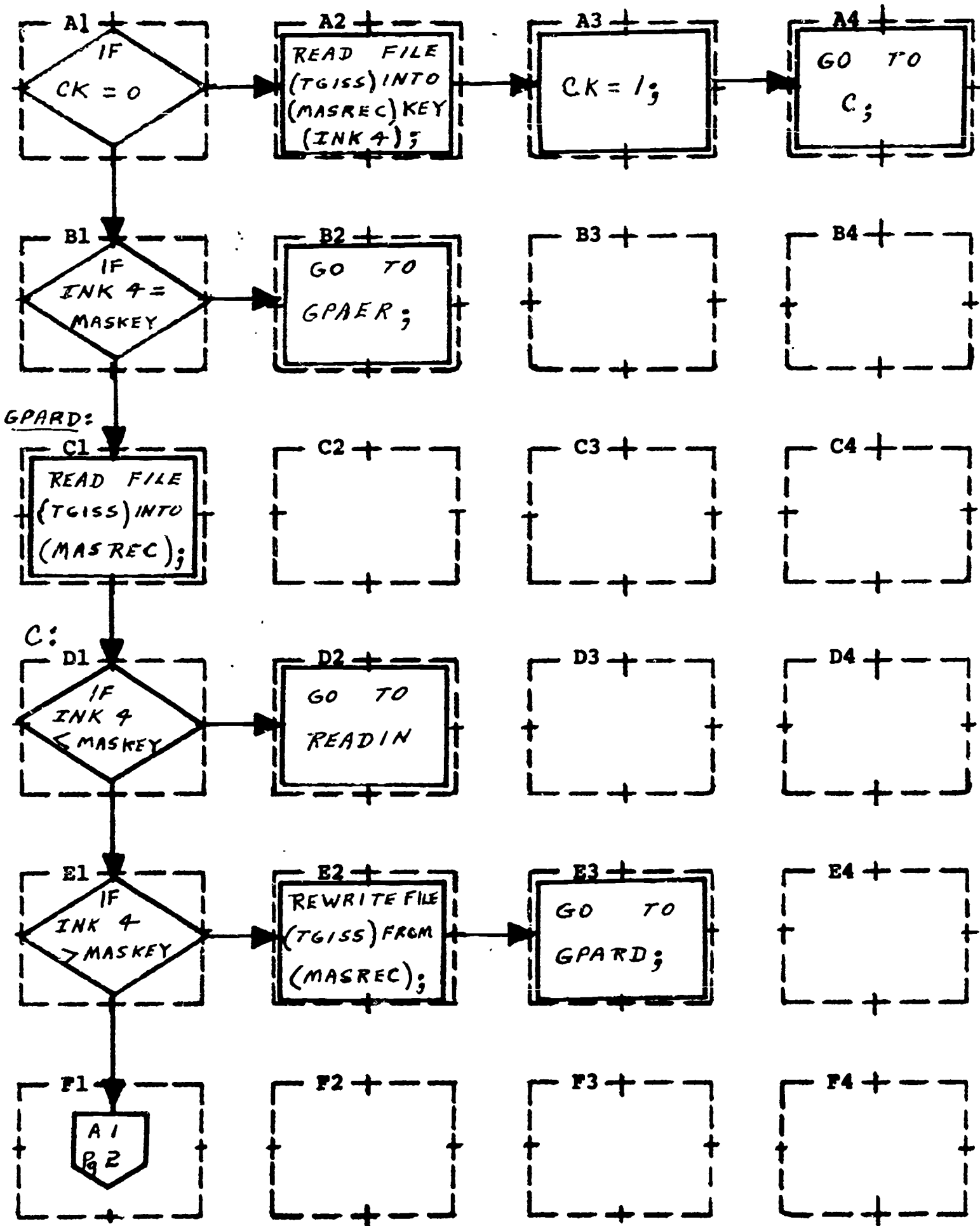
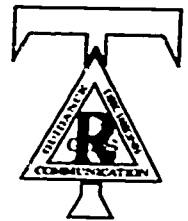

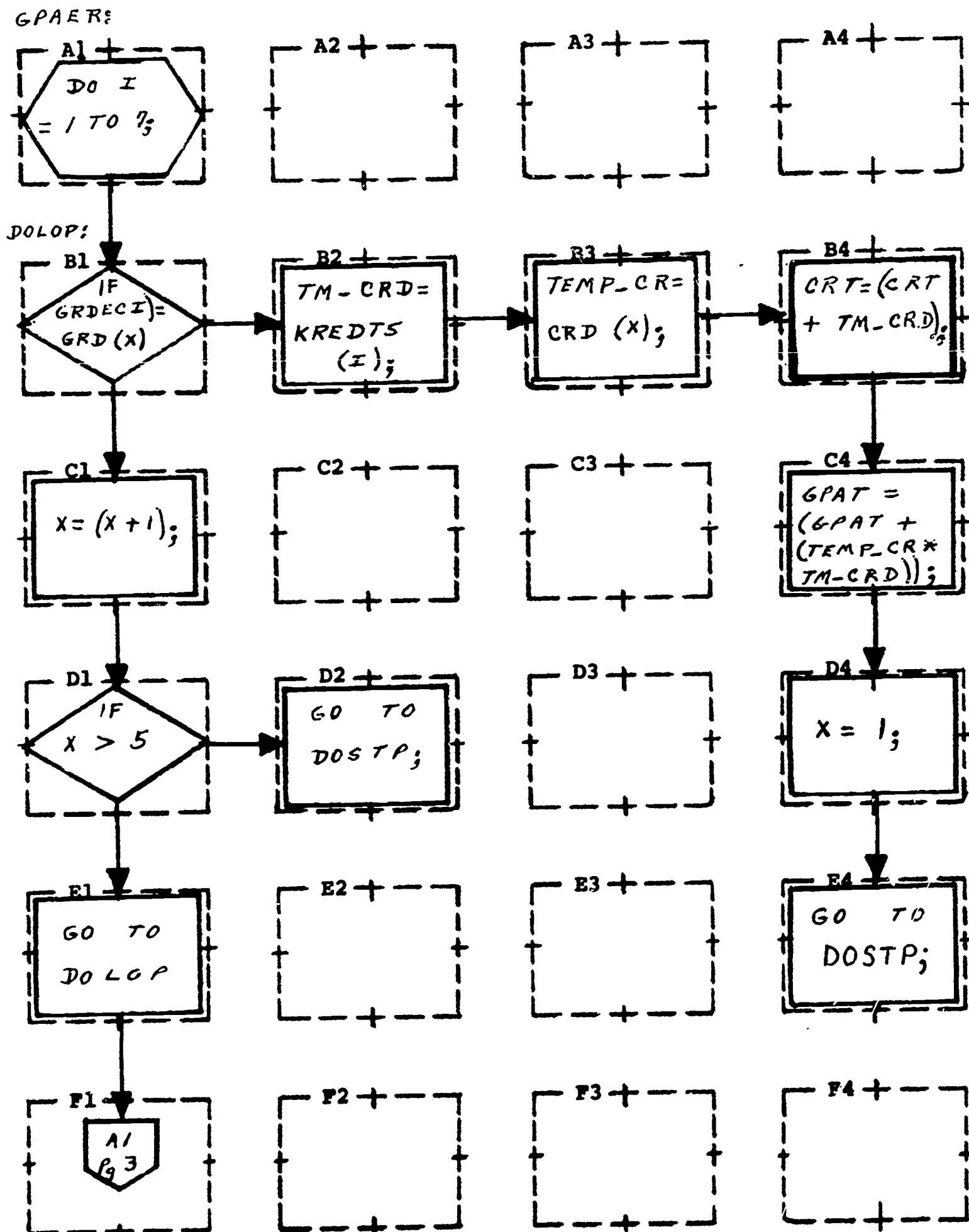
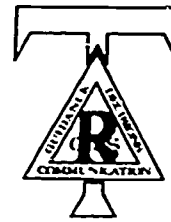

Bartlesville Public Schools - TGISS



Title: WK9GPA

Page: 3

Chart: UPDATE

Date: 10/6/69

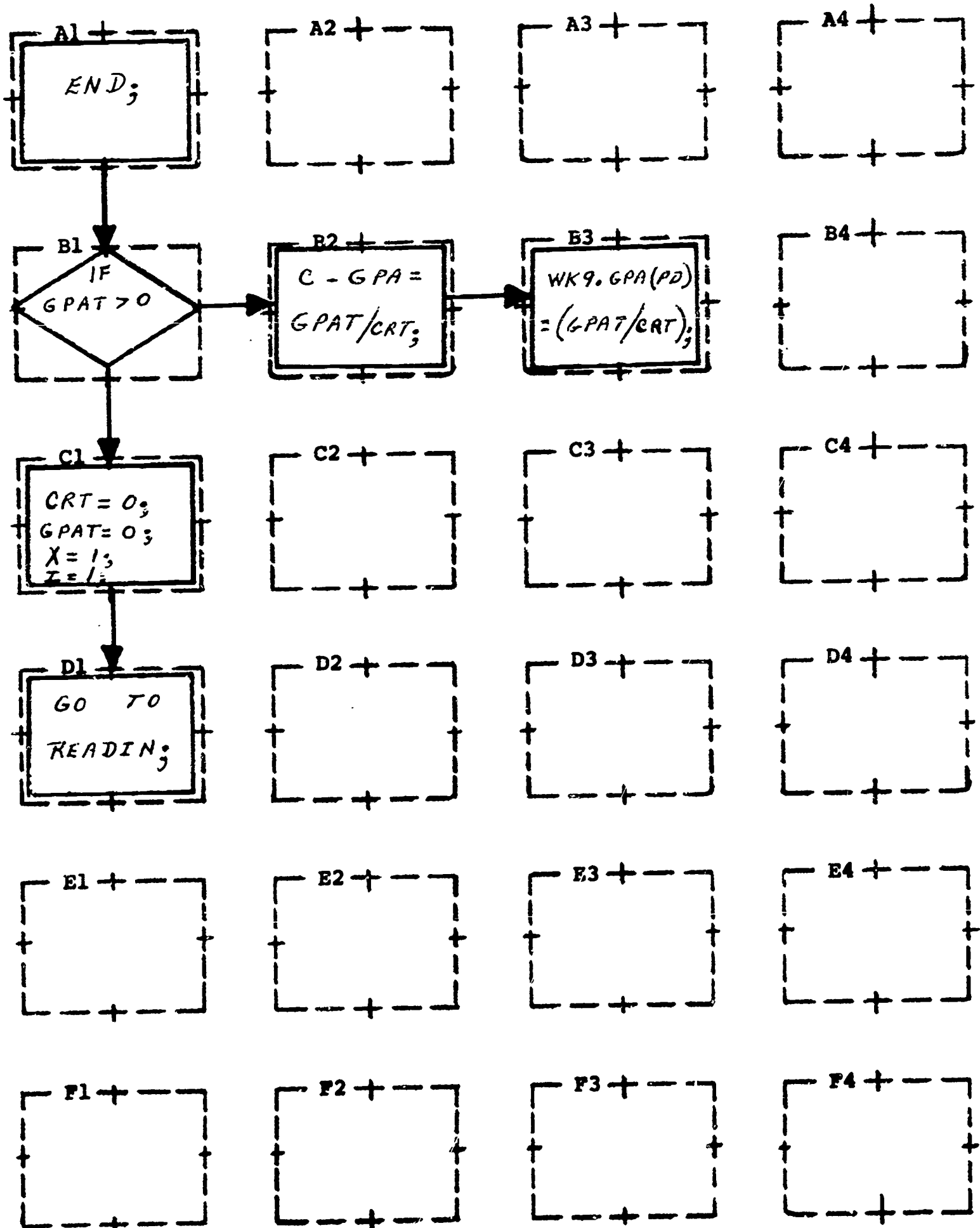



Title: REVISE

Page: 1

Chart: UPDATE

Date: 10/6/69

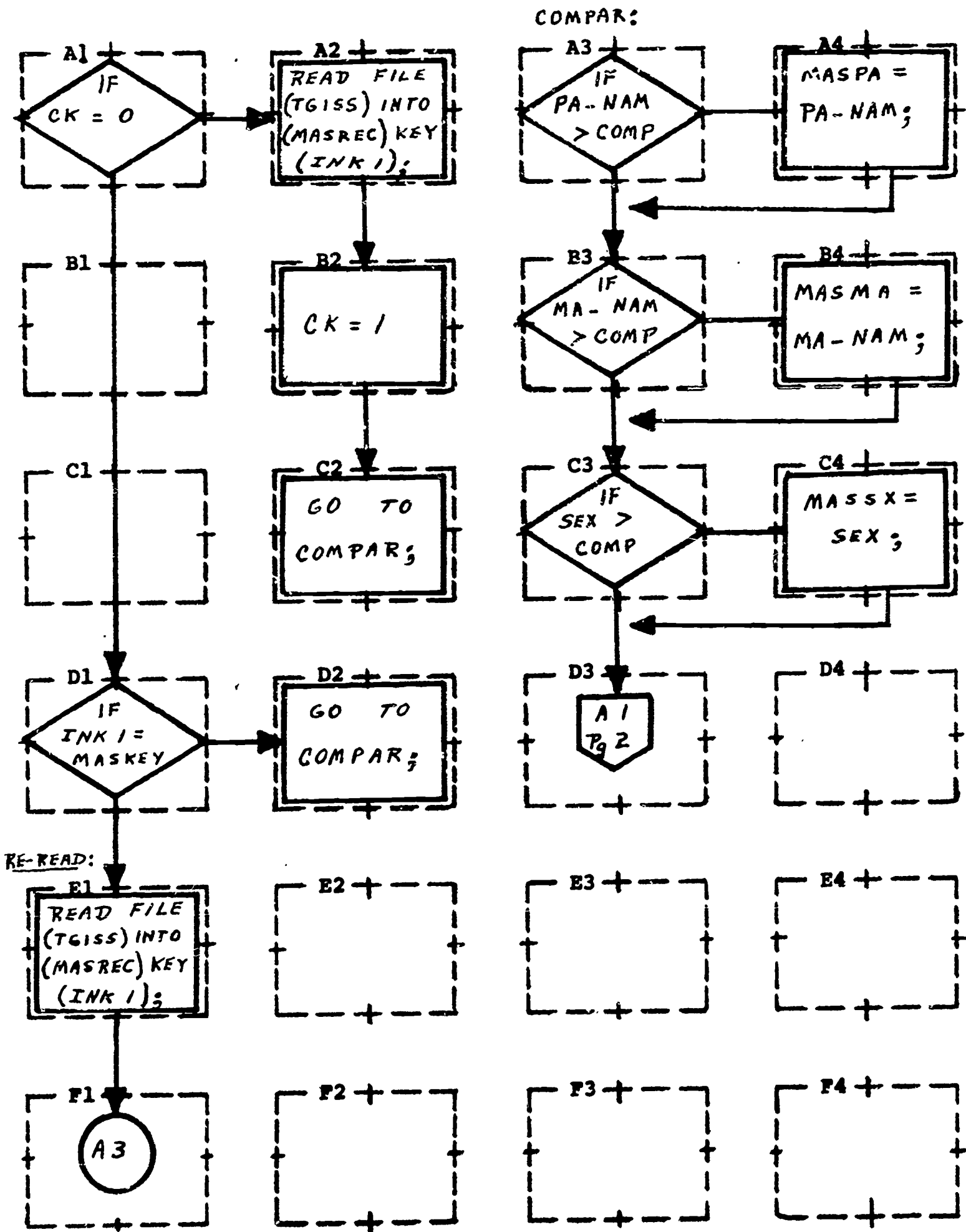



Title: REVISE

Page: 2

Chart: UPDATE

Date: 7/16/69

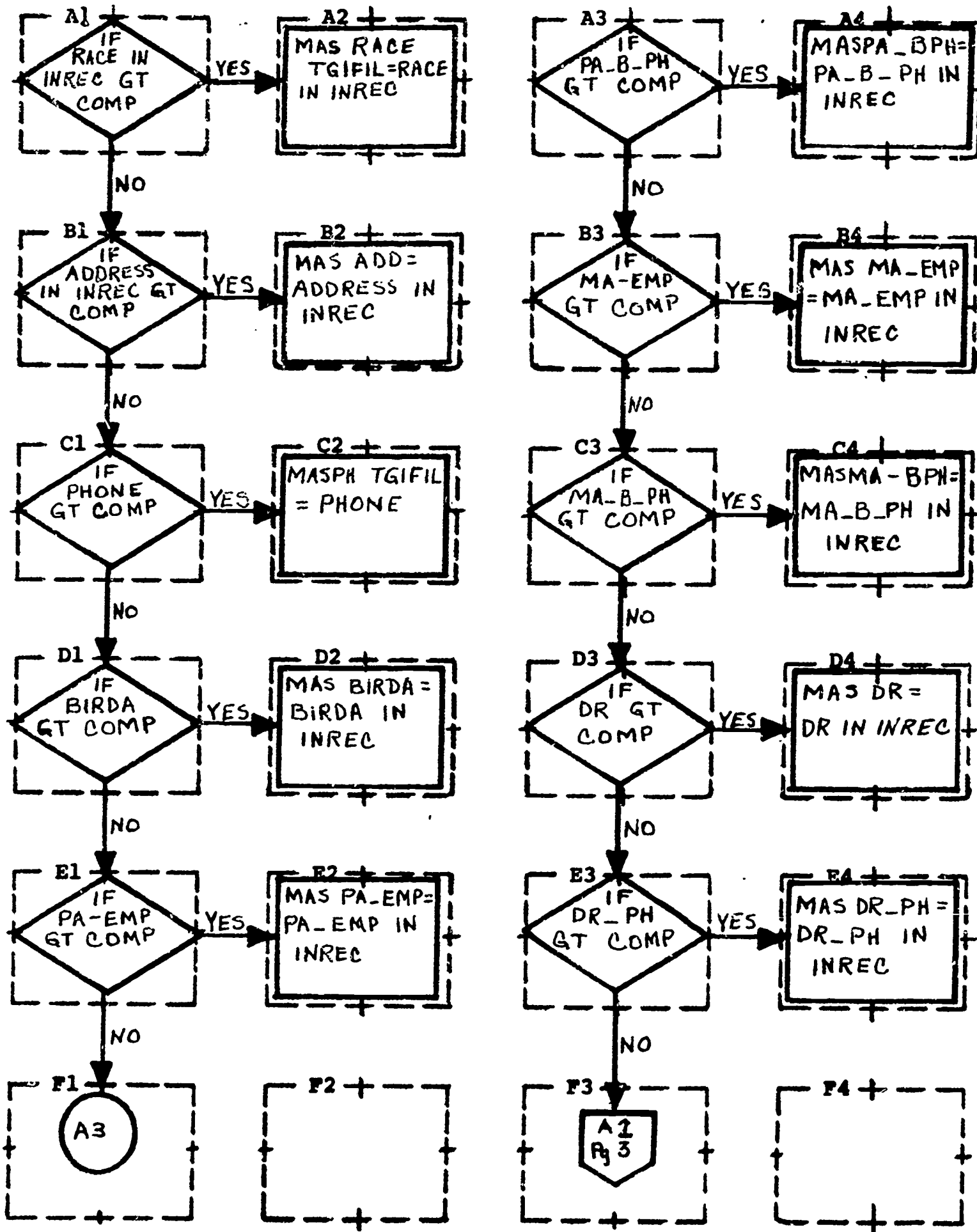



Title: REVISE

Page: 3

Chart: UPDATE

Date: 7/16/69

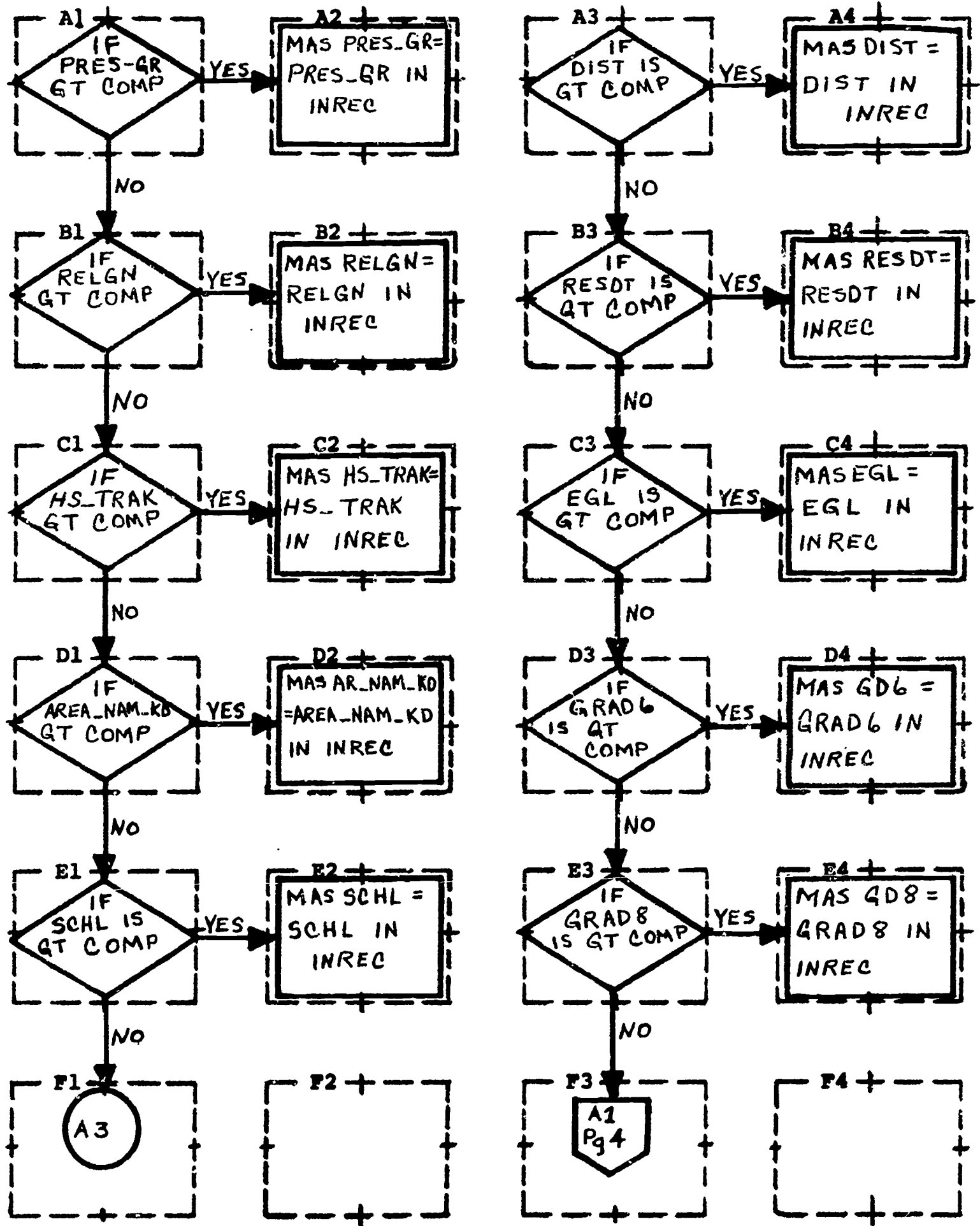



DIEZ:

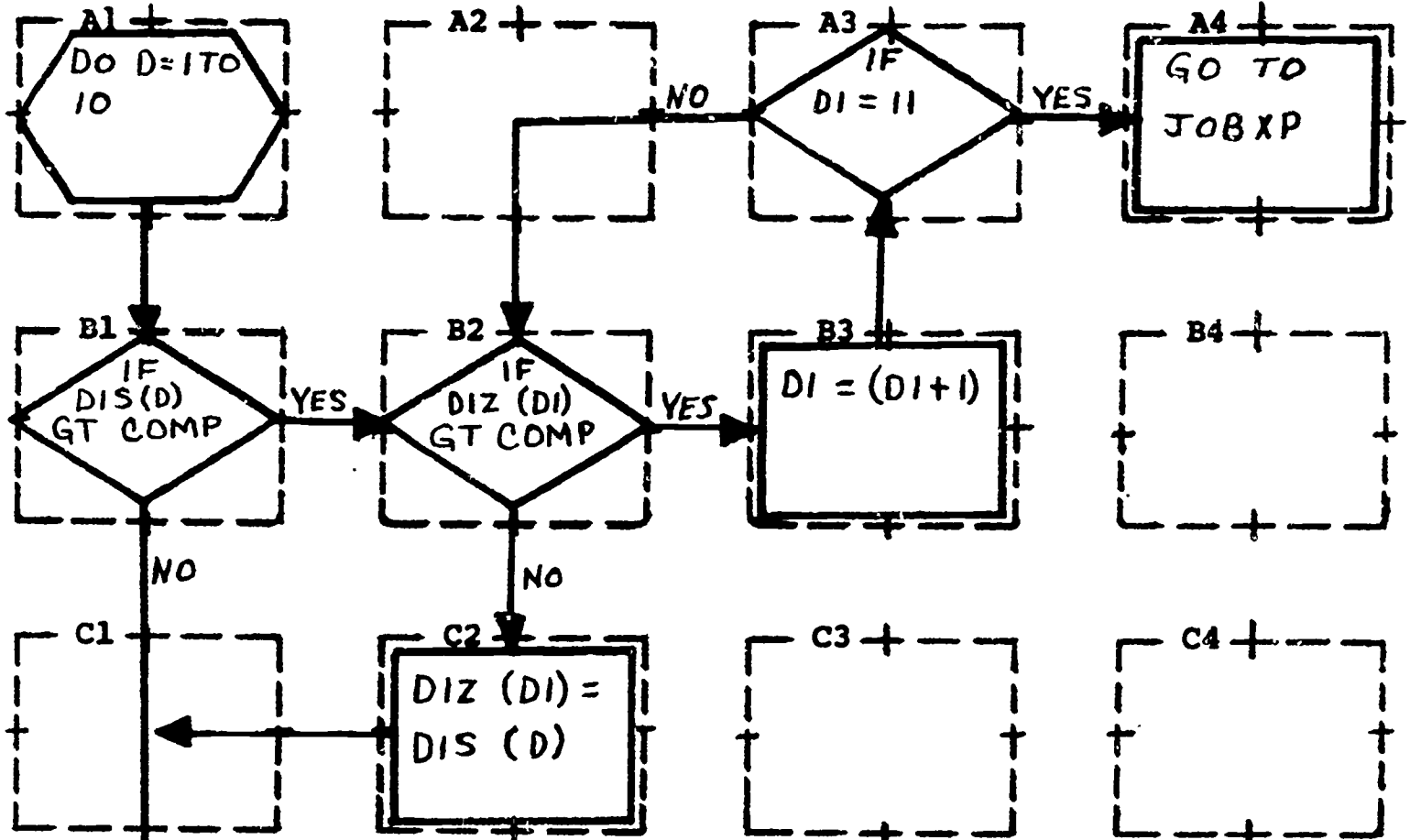

OUT:

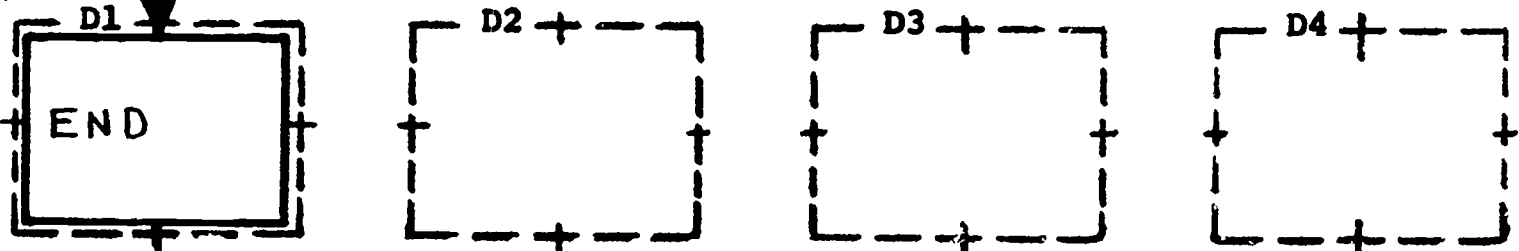

JOBXP:

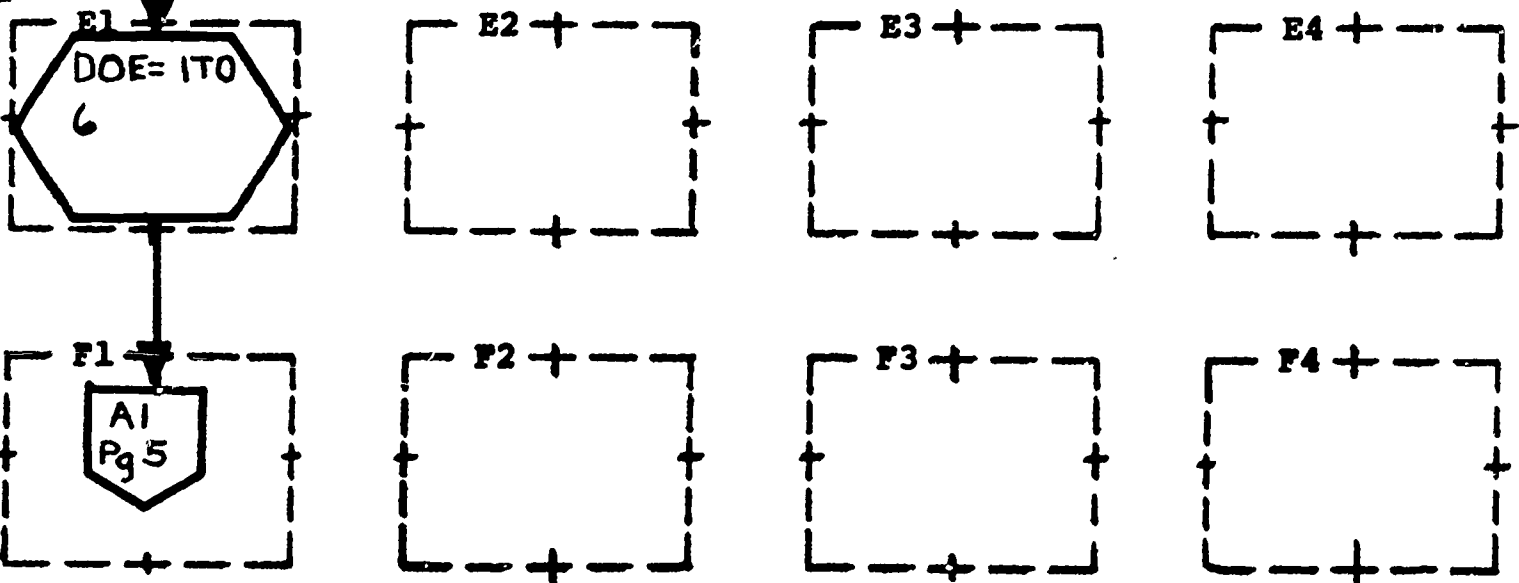



Title: REVISE

Page: 5

Chart: UPDATE

Date: 7/16/69

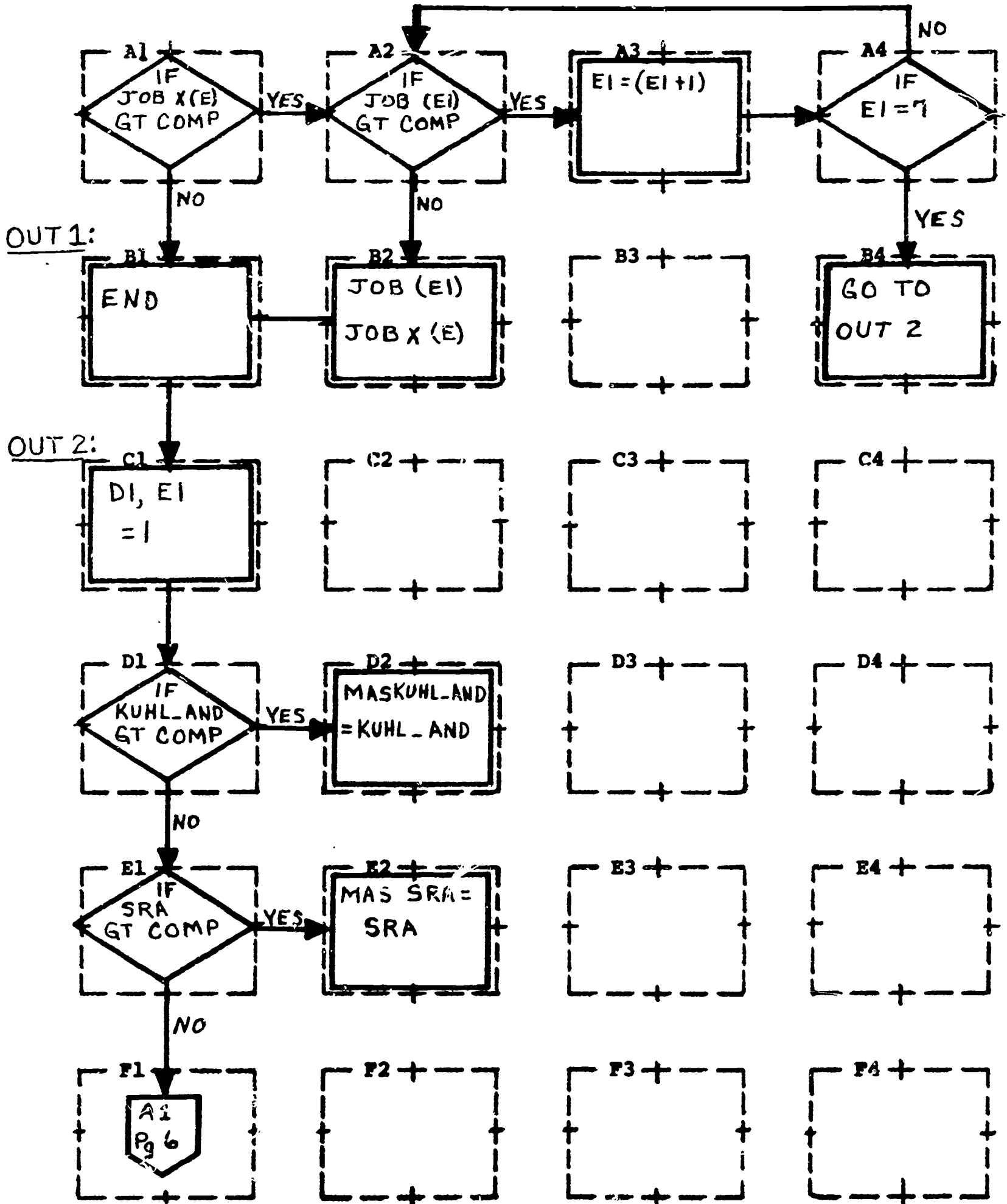

Bartlesville Public Schools - TGISS

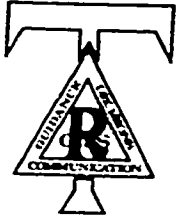

Title: REVISE

Page: 6

Chart: UPDATE

Date: 7/16/69

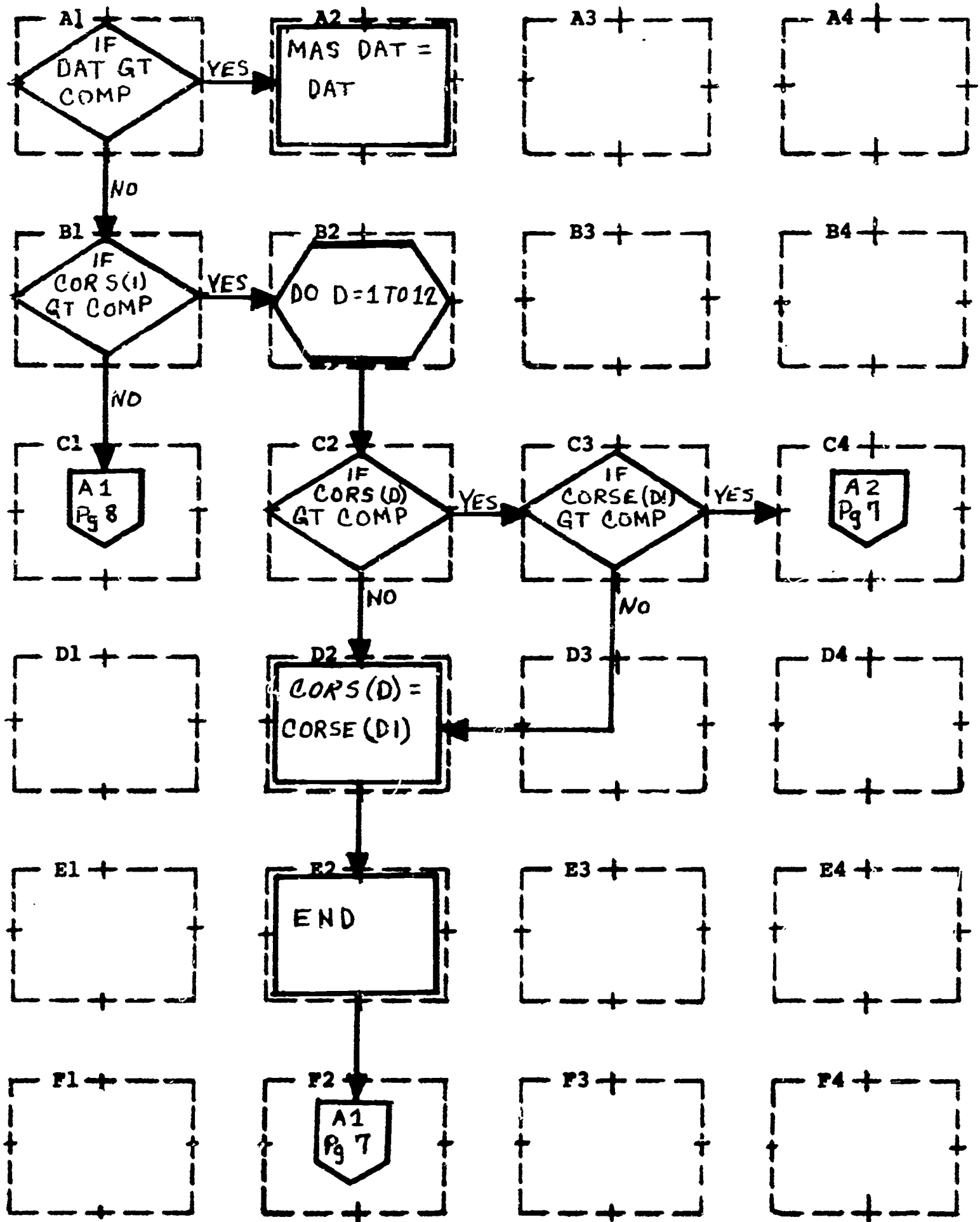

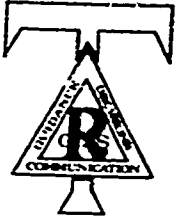

Title: REVISE

Page: 7

Chart: UPDATE

Date: 7/16/69

XSCP:

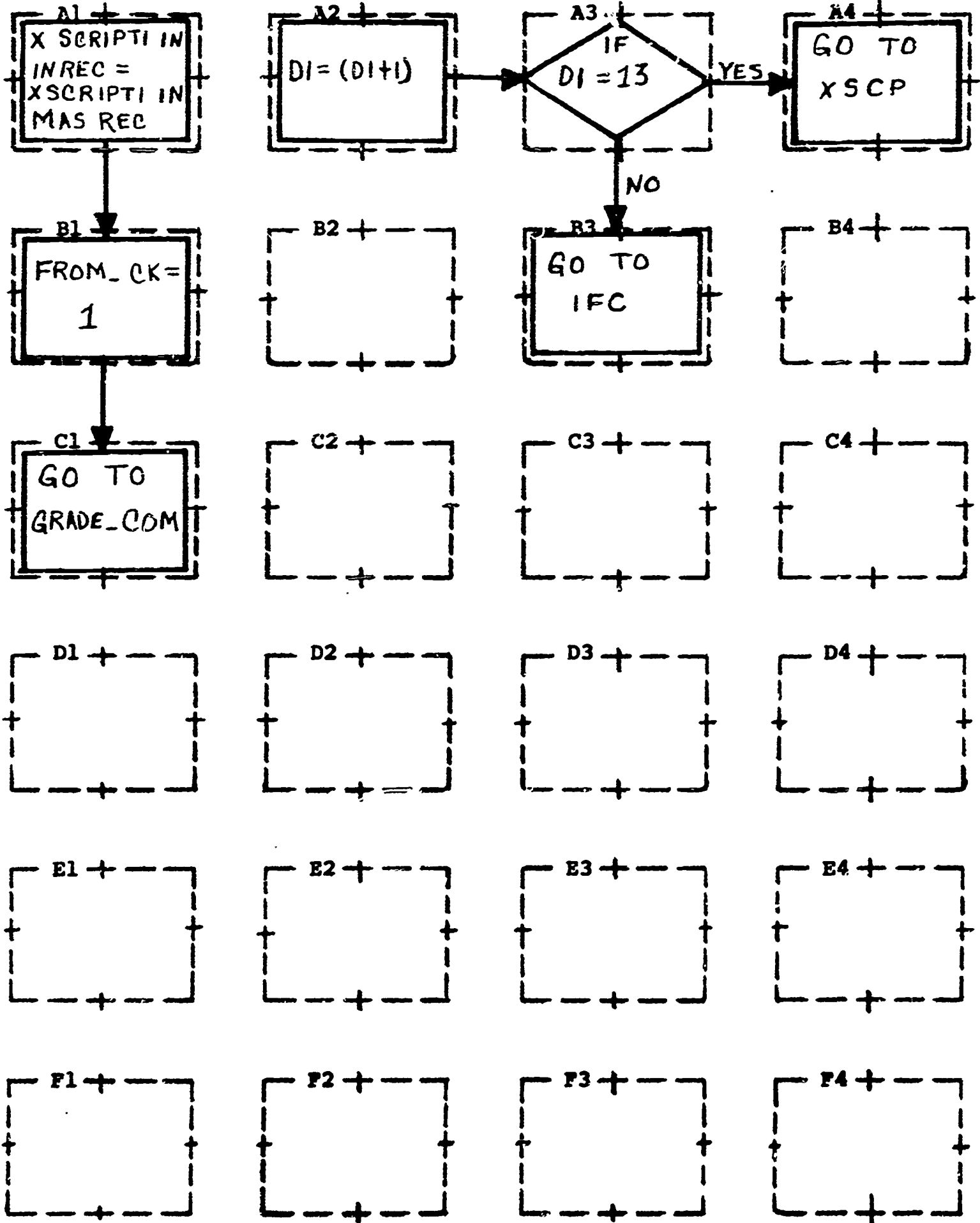

Bartlesville Public Schools - TGISS



Title: REVISE

Page: 8

Chart: UPDATE

Date: 7/16/69

RECORDS:

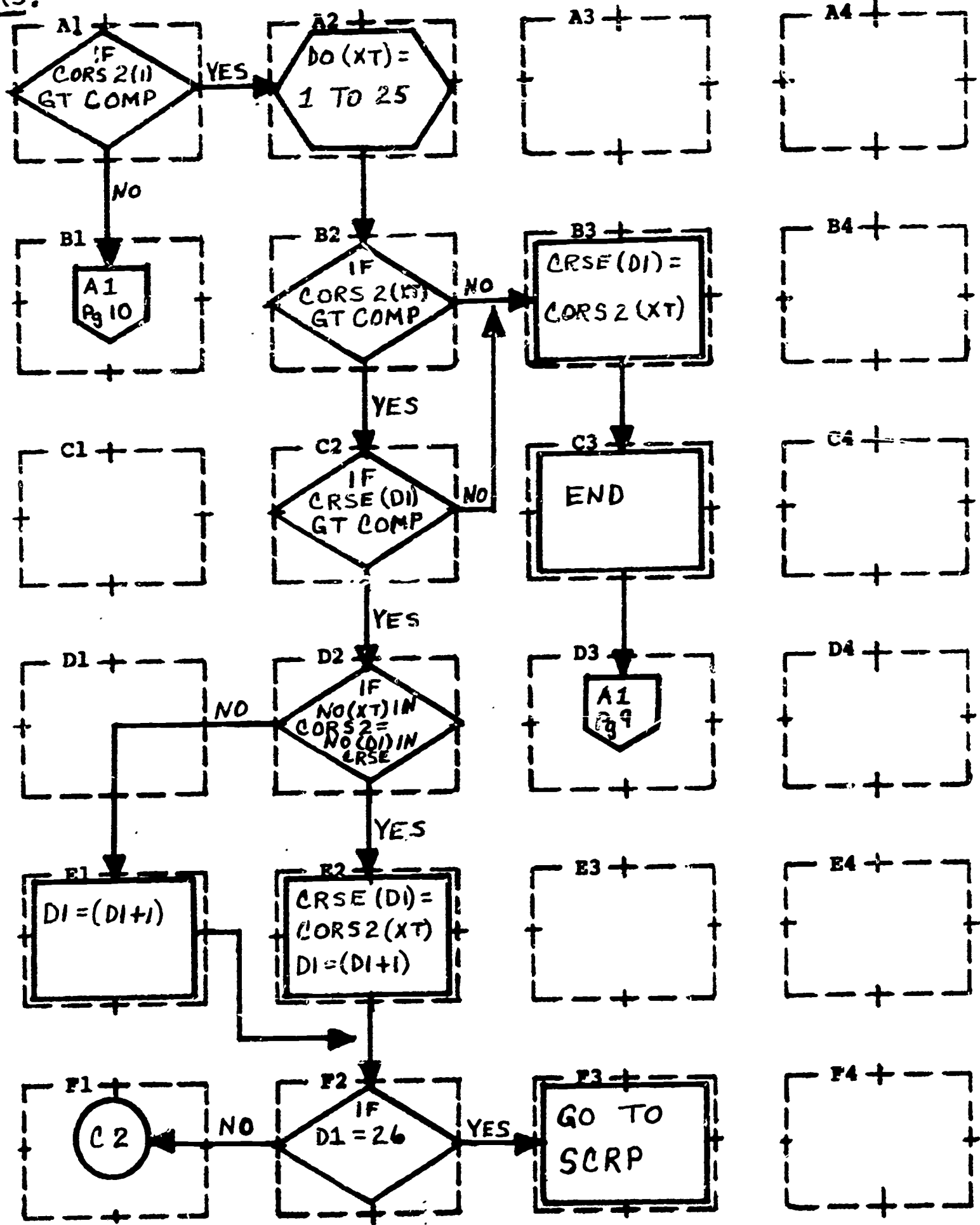

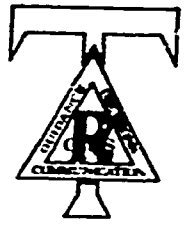

Title: REVISE

Page: 9

Chart: UPDATE

Date: 7/16/69

SCRIP:

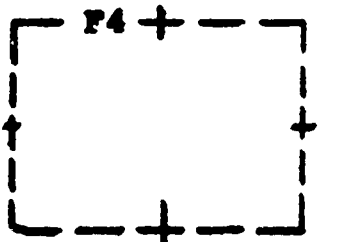
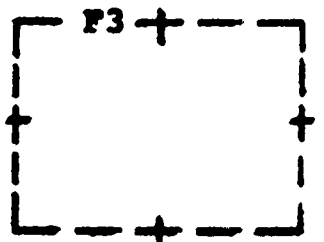
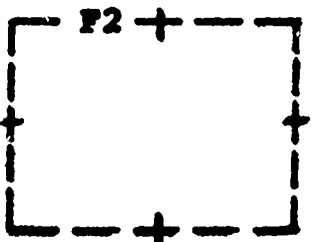
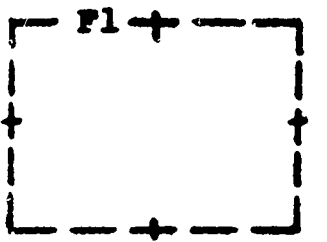
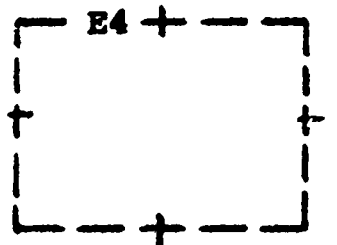
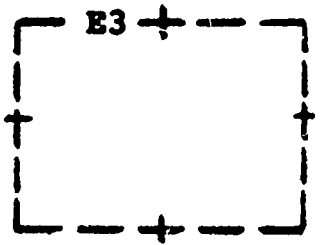
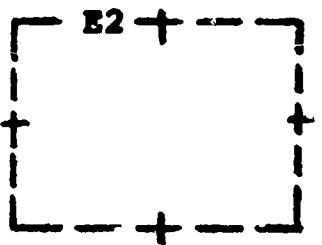
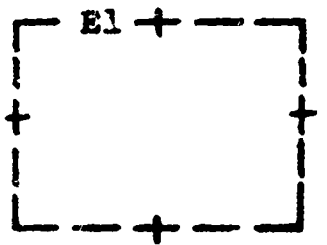
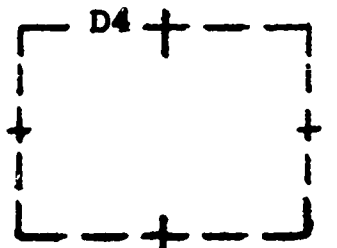
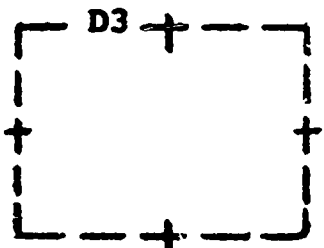
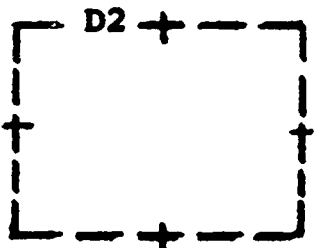
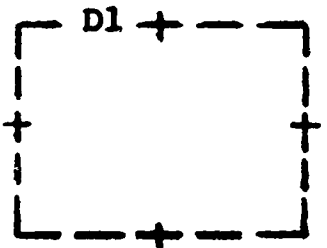
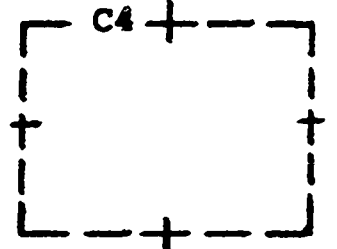
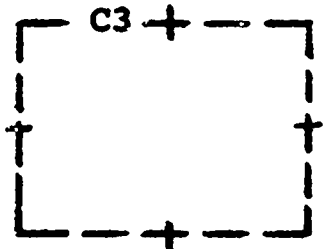
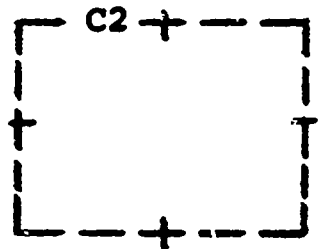
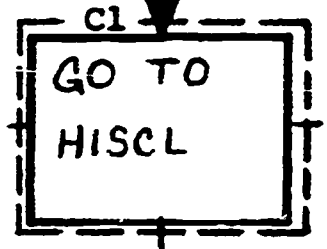
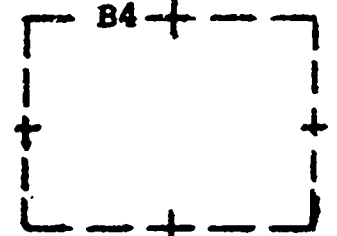
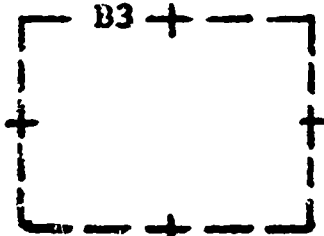
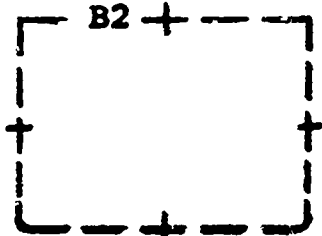
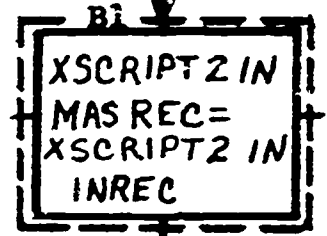
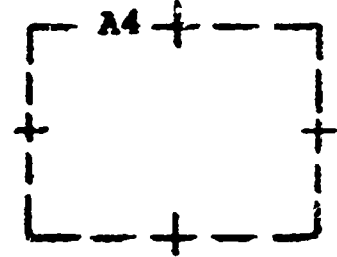
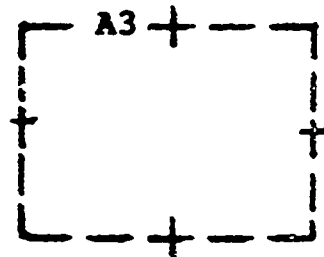
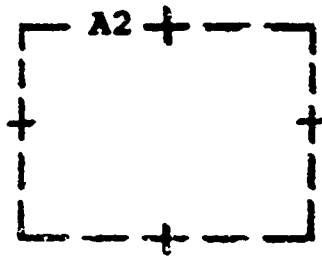
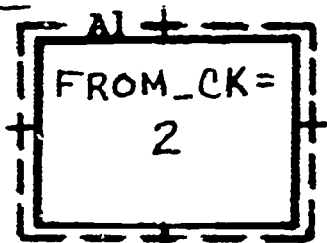



OFCORS;

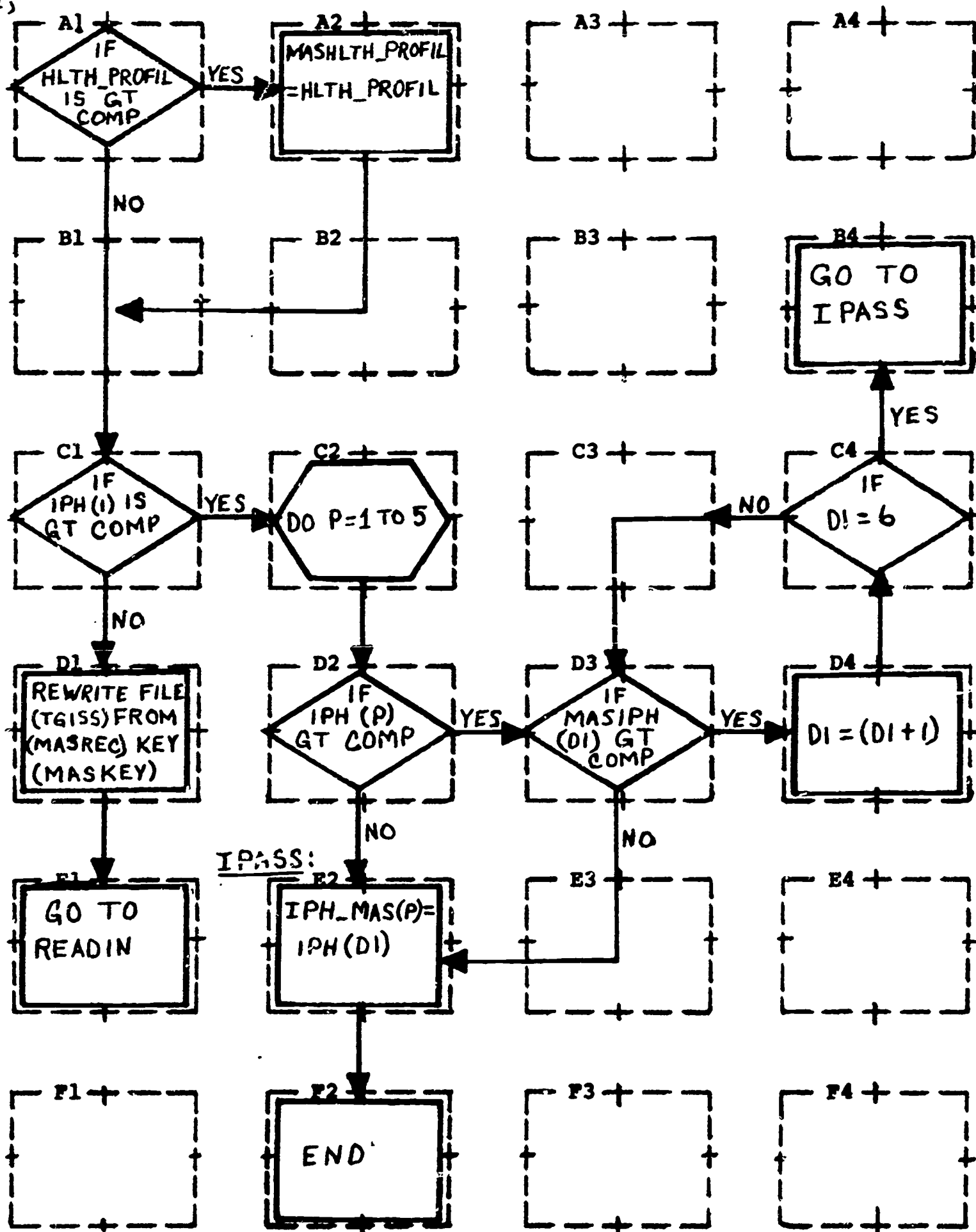

Bartlesville Public Schools - TGISS



Title: CLOSER

Page: 1

Chart: UPDATE

Date: 7/16/69

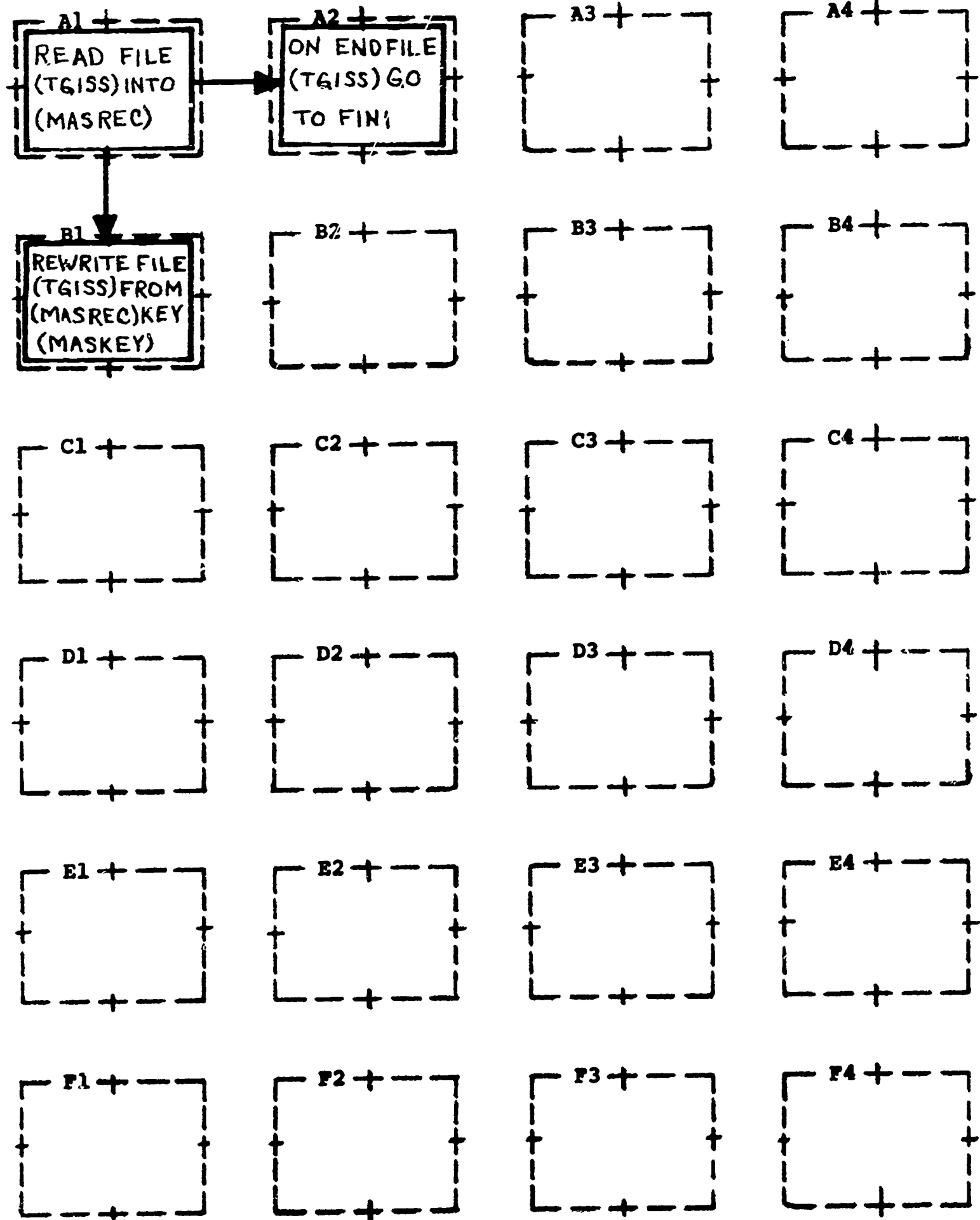

Bartlesville Public Schools - TGISS

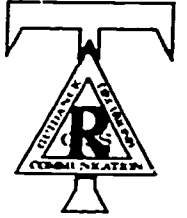

Title: FINI Page: 1

Chart: UPDATE Date: 7/16/69

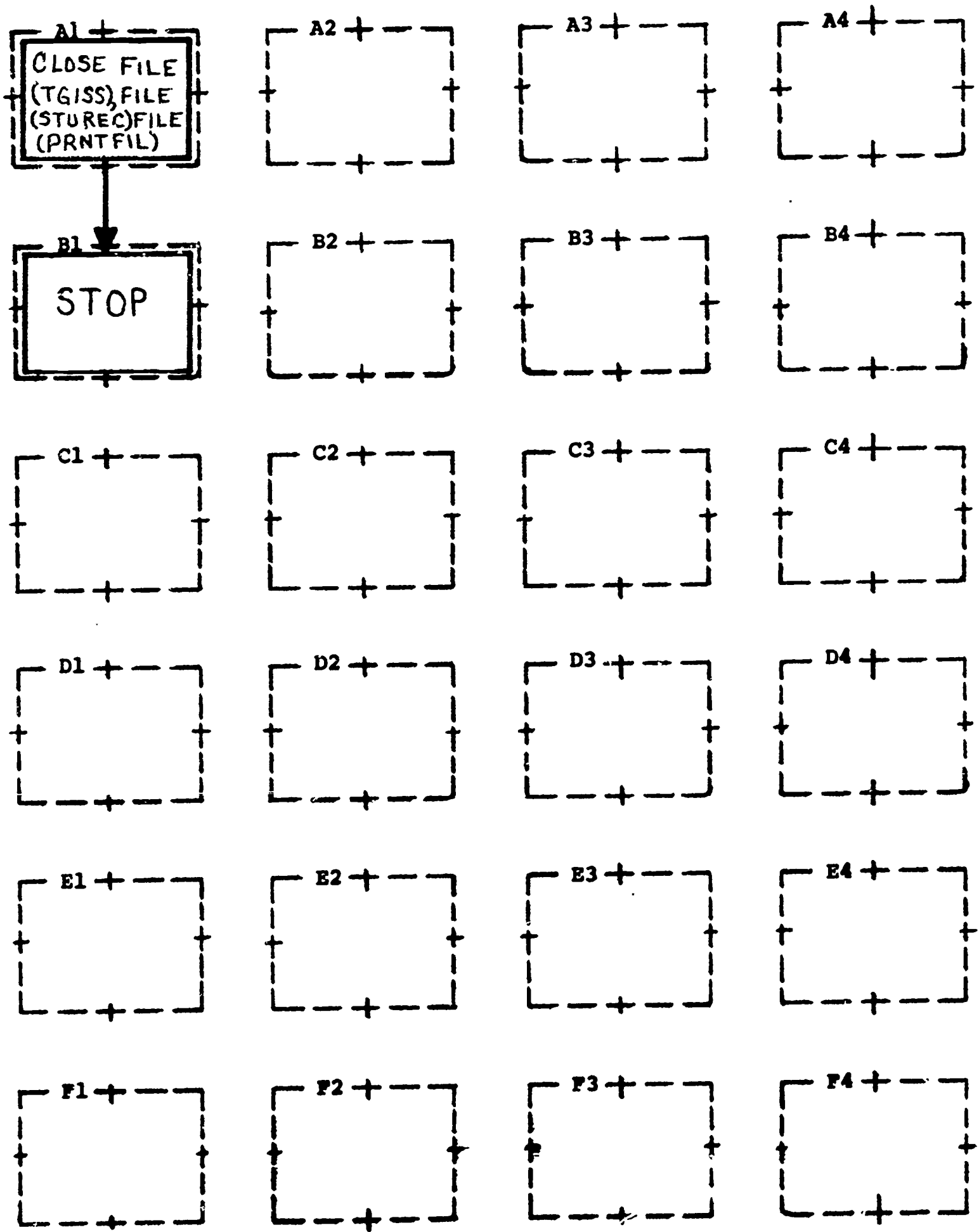

C. 1. *Sign-On*

Sign-On Format:

SGON/SOCIAL SECURITY NUMBER

The FASTER message control program equates the inquiry from the terminal to a user module using the programmer defined transaction processing description (TPD). The FASTER system then writes the inquiry to the logging data set. Security is maintained by requiring the current terminal user to 'unlock' the terminal by matching his social security number to a programmer supplied, on-line data record. The terminal is now ready to accept inquiries and respond with appropriate student data records.

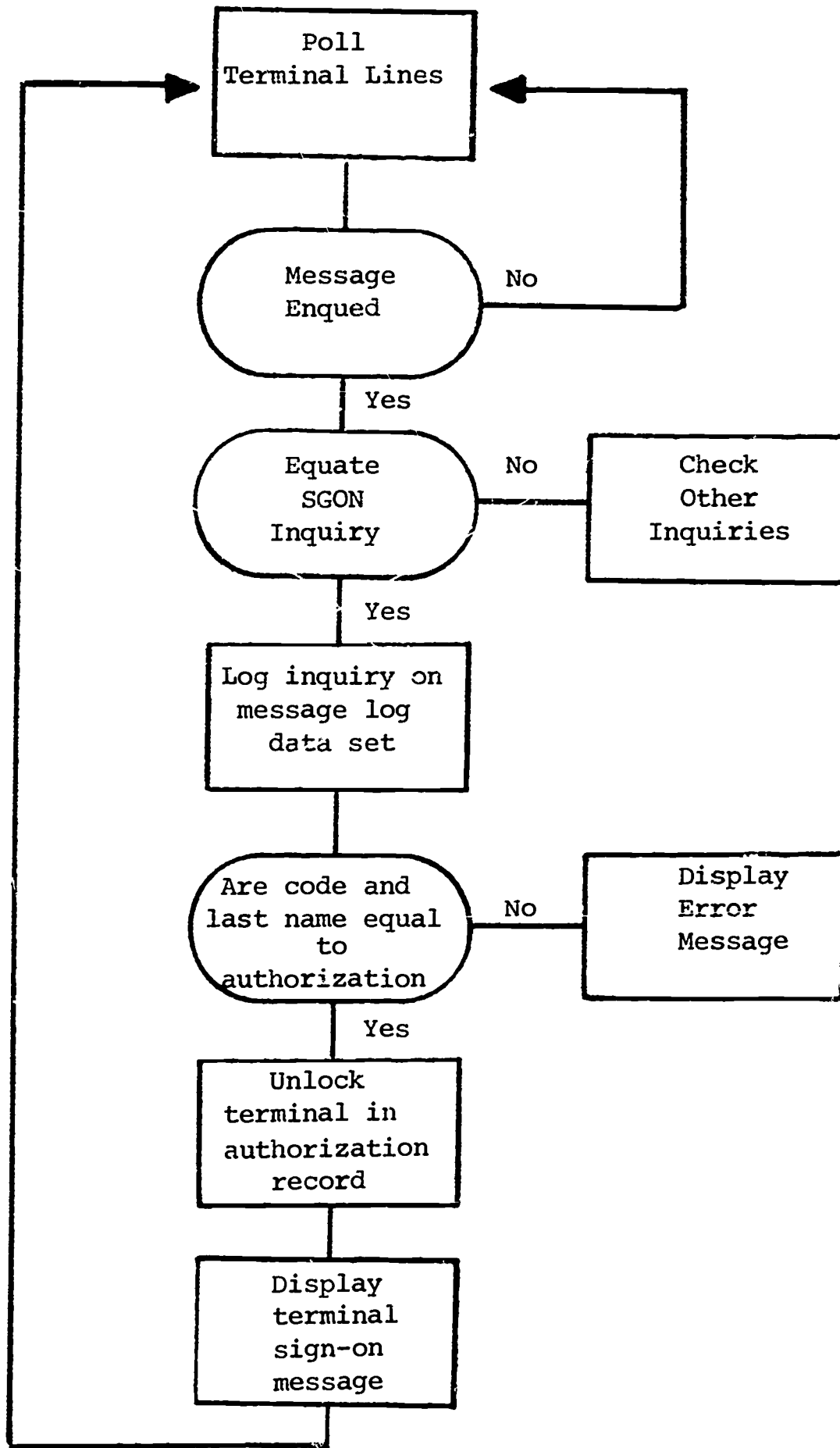

C. 2. Sign-Off

Sign-Off inquiry format:

SGON/SOCIAL SECURITY NUMBER

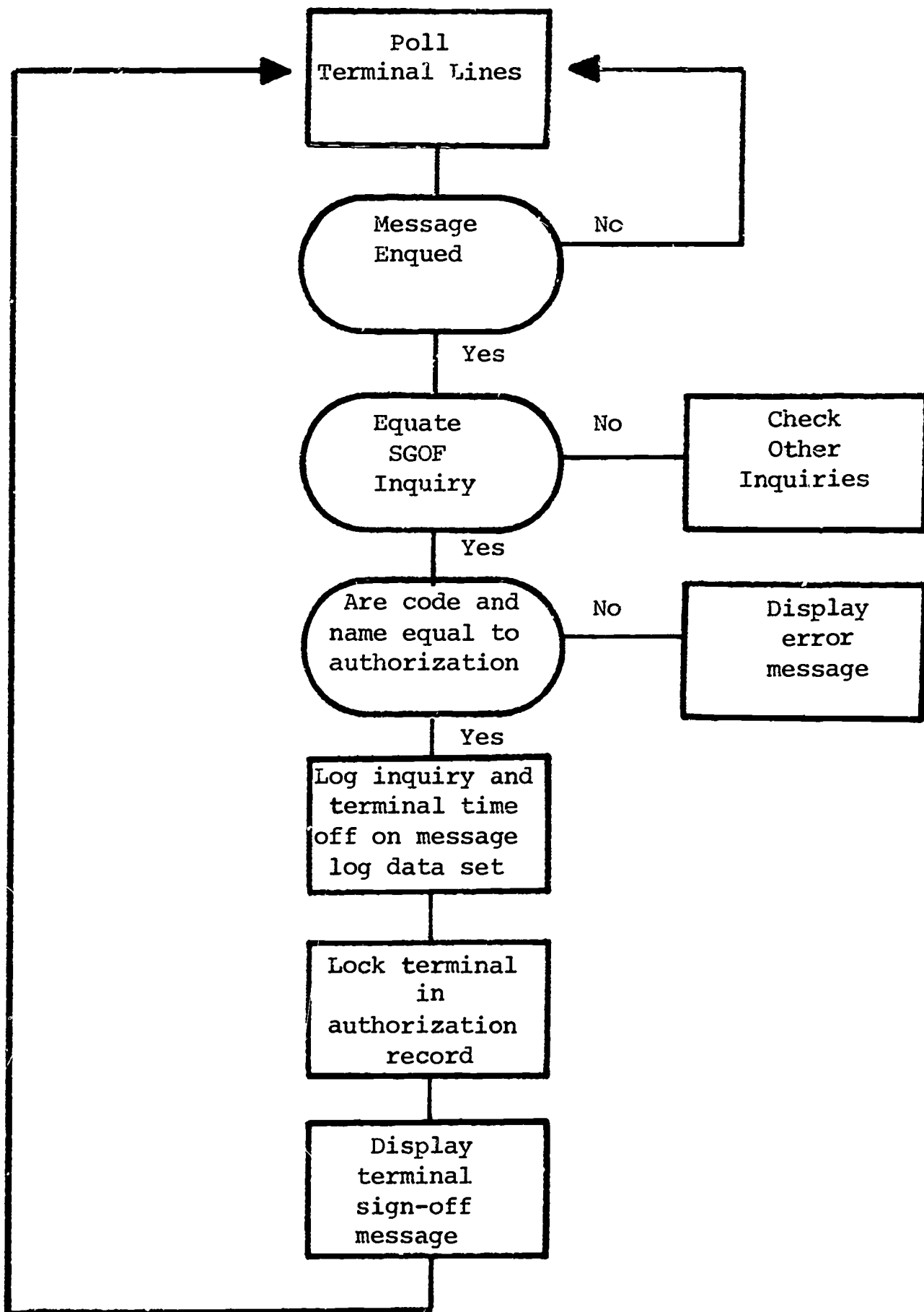

C. 3. Student Data Access Routines

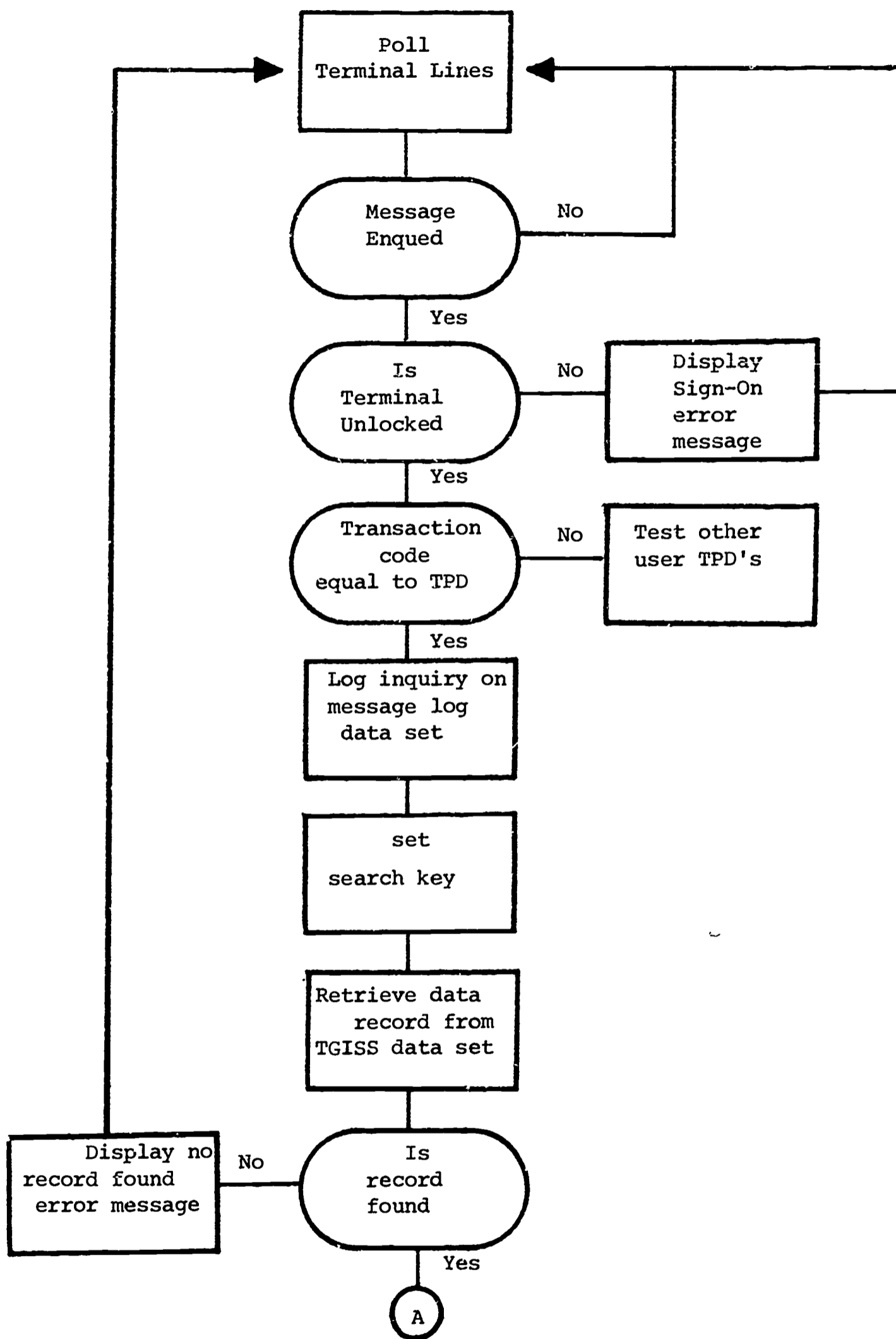

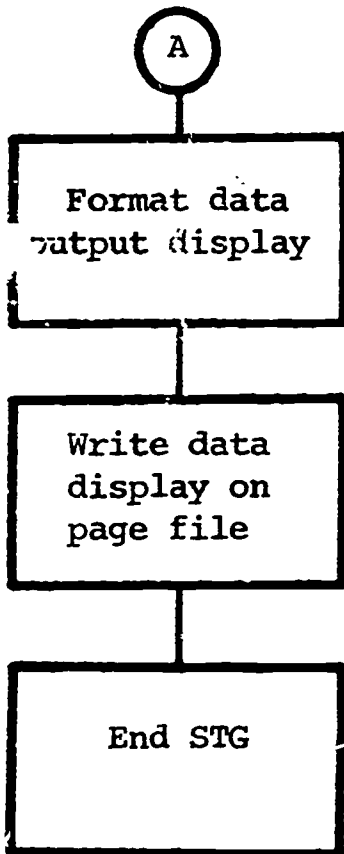

3

PART THREE

TGISS

DATA UPDATE AND REVISION

SPECIFICATIONS

DATA UPDATE AND REVISION SPECIFICATIONS

Total Guidance Information Support System (TGISS)

I. Introduction

This document is a functional specification defining the input data formats to update, delete, or revise data in the TGISS data base. Type-of-action codes (TOA) will be defined for each type of transaction and must be applied to specific student records. These student records will be identified by use of a student number.

Section II is a general description of the TGISS data base of student records. Section III defines transactions which can be applied to this data base. Section IV explains the system error messages. Section V explains the program which generates the terminal identification file to identify the on-line terminals to the FASTER modules. Section VI explains the program which generates the counselor identification file used to verify user's sign-on code.

II. Data Base Description

The Total Guidance Information Support System data will reside on a 2314 disk pack and has been generated using the indexed sequential access method (ISAM). This access method allows direct access of student data records for transmission to remote 2260 terminals and also allows the data base to be updated sequentially.

The student data has been combined into one student record which occupies 1940 bytes of storage. Each student record is uniquely

identified by a student number which occupies bytes 2 through 7 of the student record. All access and/or revision to the data base must be done based on student-ID-number. (Card columns 1 - 6).

The data contained in the student record is defined as follows:

- 1 Master Record
 - 2 General Data
 - 2 Health Record
 - 2 Work Record
 - 2 Standard Test Scores
 - 2 Transcript 1 (7 & 8th grades)
 - 2 Transcript 2 (9 thru 12th grades)
 - 2 Grade Point Averages
 - 2 Absences
 - 2 Interests-Preferences-Honors
 - 2 Health Profile
 - 2 Current Schedule

The data base was built with data which was available for each student at the time of data collection. In order that each student's data record is current and contains all applicable data, the student data base must be updated and revised as student data becomes available.

Data fields which must be revised and kept current as the student progresses through his course of study are:

- Transcript 2
- Absences
- Current Schedule
- Health Record

The Grade-Point-Averages will be computed and added to the student record as a student's courses are added to his record.

III. *Data Addition, Deletion, and Revision Transactions*

A. *Data Formats*

The fixed portion of each card is student-ID-number (columns 1-6) and card-code (columns 79-80). Columns 7 through 77 will contain student record data to be input to the TGISS student records. The input cards required for initial as well as subsequent students to be added to the TGISS student file will be cards 01, 02, 03, X4, X5, 06, X7, X8, 09, XA, and 0B. When multiple cards are input for X designated card types, they must be sequentially numbered by punching in the first position of the card code (X) beginning with a numeric zero (0) and continuing through nine (9). Each group of cards input to add, revise, or delete student data on the TGISS file must have a master card (01) in the group.

The cards used to input absences, current schedules, and nine week student grades are represented in Figure 1 by card codes 0C, XD, and 0E, respectively. It is not necessary to input a master card (01) with these card types.

The type-of-action code (TOA) must be included in cards 01 (master card), 0C, 0D, and 0E. Data can be added to or revised in the student record by using a master card (01) with a student-ID-number, student name, and TOA code followed by appropriate card types and their included data fields. The TOA code for adding data will be (A), and (R) for revising data.

A student's data may be completely deleted from the TGISS data file by using a master card (01) and a TOA code of (D).

When card types 0C, 0D, and 0E are used to input absences, current schedule, and nine week student grades the TOA code field is blank. Card formats are as follows:



GENERAL CARD CONT'D - 03

ID	FAMILY DOCTOR LAST NAME	DOCTOR PHONE	CURRENT GRADE	CHURCH	HS TRACK	SCHOOL TRANSFERRED FROM	YR GRAD		CARD CODE
							6TH	8TH	
777777	7777777777777777	77777777	77777777	77777777777777	77777777777777	77777777777777	7777	777777777777777777	7777
588888	8888888888888888	88888888	88888888	88888888888888	88888888888888	88888888888888	8888	8888888888888888	8888
999999	9999999999999999	99999999	99999999	99999999999999	99999999999999	99999999999999	9999	9999999999999999	9999
1 2 3 4 5 6	7 8 9 10 11 12 13 14 15 16 17 18 19	20 21 22 23 24 25 26 27 28	29 30 31 32 33 34 35 36 37 38 39 40 41	42 43 44 45 46 47 48 49 50 51 52 53 54 55 56 57 58 59	60 61 62 63 64 65 66 67 68 69 70 71 72 73 74 75 76 77 78 79	80 81 82 83 84 85 86 87 88 89 90 91 92 93 94 95 96 97 98 99			

HEALTH RECORD CARD - X4

ID	NAME OF DISEASE	DT OF DS		NAME OF DISEASE	DT OF DS		NAME OF DISEASE	DT OF DS		CARD CODE
		DT	VA		DT	VA		DT	VA	
777777	7777777777777777	7777	7777	7777777777777777	7777	7777	7777777777777777	7777	7777	7777777777777777
888888	8888888888888888	8888	8888	8888888888888888	8888	8888	8888888888888888	8888	8888	8888888888888888
999999	9999999999999999	9999	9999	9999999999999999	9999	9999	9999999999999999	9999	9999	9999999999999999
1 2 3 4 5 6	7 8 9 10 11 12 13 14 15 16 17 18 19 20 21 22 23 24 25 26 27 28 29 30 31 32 33 34 35 36 37 38 39 40 41 42 43 44 45 46 47 48 49 50 51 52 53 54 55 56 57 58 59 60 61 62 63 64 65 66 67 68 69 70 71 72 73 74 75 76 77 78 79 80									





TRANSCRIPT FOR 7TH & 8TH GRADES - X7

ID	COURSE			COURSE			COURSE			COURSE			CARD CODE
	NO.	NAME	GRADE	NO.	NAME	GRADE	NO.	NAME	GRADE	NO.	NAME	GRADE	
	7	7	7	7	7	7	7	7	7	7	7	7	
	8	8	8	8	8	8	8	8	8	8	8	8	
	9	9	9	9	9	9	9	9	9	9	9	9	
	1	2	3	4	5	6	7	8	9	10	11	12	

TRANSCRIPT FOR 9TH, 10TH, 11TH and 12TH GRADES - X8

ID	COURSE				COURSE				COURSE				CARD CODE
	NO.	NAME	GRADE LEVEL	CREDITS	NO.	NAME	GRADE LEVEL	CREDITS	NO.	NAME	GRADE LEVEL	CREDITS	
	7	7	7	7	7	7	7	7	7	7	7	7	
	8	8	8	8	8	8	8	8	8	8	8	8	
	9	9	9	9	9	9	9	9	9	9	9	9	
	1	2	3	4	5	6	7	8	9	10	11	12	



CURRENT SCHEDULE CARD - XD

ID	COURSE NAME	LOCATION	PERIOD	TEACHER'S NAME	COURSE NAME	LOCATION	PERIOD	TEACHER'S NAME	CARD CODE
777777	7777777777	7777777777	7777777777	7777777777	7777777777	7777777777	7777777777	7777777777	7777
688888	8888888888	8888888888	8888888888	8888888888	8888888888	8888888888	8888888888	8888888888	8888
999999	9999999999	9999999999	9999999999	9999999999	9999999999	9999999999	9999999999	9999999999	9999
1 2 3 4 5 6 7 8 9 10 11 12 13 14 15 16 17 18 19 20 21 22 23 24 25 26 27 28 29 30 31 32 33 34 35 36 37 38 39 40 41 42 43 44 45 46 47 48 49 50 51 52 53 54 55 56 57 58 59 60 61 62 63 64 65 66 67 68 69 70 71 72 73 74 75 76 77 78 79 80									

ID	COURSE		COURSE		COURSE		COURSE		COURSE		COURSE		CARD CODE
	NO.	GRADE	NO.	GRADE	NO.	GRADE	NO.	GRADE	NO.	GRADE	NO.	GRADE	
77777	77777	77777	77777	77777	77777	77777	77777	77777	77777	77777	77777	77777	7777
68888	88888	88888	88888	88888	88888	88888	88888	88888	88888	88888	88888	88888	8888
99999	99999	99999	99999	99999	99999	99999	99999	99999	99999	99999	99999	99999	9999
1 2 3 4 5 6 7 8 9 10 11 12 13 14 15 16 17 18 19 20 21 22 23 24 25 26 27 28 29 30 31 32 33 34 35 36 37 38 39 40 41 42 43 44 45 46 47 48 49 50 51 52 53 54 55 56 57 58 59 60 61 62 63 64 65 66 67 68 69 70 71 72 73 74 75 76 77 78 79 80													

B. *Data Additions*

Data to be added to the TGISS student data file is divided into two categories in the master record.

Data fields contained in category 1:

General Data	- Input cards 01, 02, 03, 09
Health Record	- Input card X4
Work Record	- Input card X5
Standard Test Scores	- Input card 06
Transcript 1	- Input card X7
Transcript 2	- Input card X8
Interests-Preferences-Honors	- Input card XA
Health Profile	- Input card 0B

Data fields contained in category 2:

Absences	- Input card 0C
Current Schedule	- Input card 0D
Nine Week GPA	- Input card 0E

Student data records to be added to the TGISS student data file in category 1 must be input with a master card (01), with a TOA code of (A). The master card must be followed by appropriate data cards to build a student record for each new student.

Student data records already on the TGISS data base to which category 1 data fields must be added are defined as being *revised* and the input cards must be preceded by a master card (01) which contains a TOA of (R).

Data in category 2 must be added to a student's data record which *already* exists on the TGISS data base and must be input using

cards 0C, weekly absence input, and XD, current schedule. The TOA code for these types of input must be a blank.

Nine week grades will be input using the OE card. The grade-point-average for each nine week period will be computed and stored in the grade-point-average portion of the student data record based on the 9-week period number as input on the OE card. The TOA code on the OE card must be blank.

TOA codes will be generated by the input verification program based on card code for card types 0C, 0D, and 0E to be used by the update program in updating absences and current schedules, and computing nine week grade point averages.

C. *Data Revisions*

Data to be revised on the TGISS student data file must be input with a master card (01) and a TOA code of (R). Data fields which can be revised are contained in:

General Data	- Input cards 01,02,03,09
Health Record	- Input card X4
Work Record	- Input card X5
Standard Test Scores	- Input card 06
Transcript 1	- Input card X7
Transcript 2	- Input card X8
Interests-Preferences-Honors	- Input card XA
Health Profile	- Input card 0B

The master card (01) must be followed by data cards containing the data fields to be revised. Any non-blank data fields input will be revised on the corresponding student record in the TGISS data base.

Courses to be added to a student's transcript (either 1 or 2) must be input with a TOA code of (R). New grade point averages will be computed when new courses are added or old courses revised.

D. *Deletion of Records*

Student data records which are obsolete in the TGISS data base can be deleted by inputting a master card (01) with a TOA code of (D). Care should be taken in using the delete transaction because once a record is deleted in error, all student data related to the deleted student record would have to be re-input to reconstruct the student data record.

E. *Special Data Conditions*

1. When the initial data collection process was undertaken some courses were input twice as a result of a student's having failed a course and retaken it. In the event that the student made a higher grade in the retaken course, the course was keypunched and input in both situations. This is a data error. GPA calculation will be in error *until* the student's course input is corrected. This can be accomplished by replacing the failed courses (grade of F) with passed courses and the retaken courses with the higher grade. Retaken courses should be flagged with an "R" in the last character of the course name field when input to replace the failed course. Courses *not* retaken can remain on file as a failed course. These course cards will be input with a student master card (01) with a TOA code of (R).

2. Revision Levels -

Student record data will be revised by field when input fields are non-blank. The lowest level which can be revised is the field level.

General Data fields may be revised by field by inputting non-blank data in the appropriate data cards.

Health Record Data may be revised by inputting name of disease, DT of DS, and DT of VA for each disease one wishes to revise. The name of disease, DT of DS, and DT of VA must occupy the same sequential positions on the input card as the data fields to be revised occupy in the student data record. Example: to revise the third disease listed on the student data record, the disease input must be in the third position of input card 04.

Work Experience must be revised by job experience block, which contains job name, vol. code, and mos. exp. The job experience block must occupy the same sequential position on the input card as the data fields to be revised occupy in the student data record.

Standard Test Scores may be revised by test block only, Kuhlman, SRA, or DAT. Valid data must be re-entered along with the data to be changed within each block.

Transcript data may be revised by course block in Transcript 1 or Transcript 2. The course blocks input to revise Transcript 1 or Transcript 2 must contain all included data fields. (See card formats X7, X8) The position

of the course blocks to be revised on the student data record is not considered in the program search, but the program will operate more efficiently if the courses to be added or revisions to the transcripts are input consecutively beginning with the first course block on the input card. Course blocks input to revise courses in a student data record must contain the same course number as the course block to be revised. Important: Course data to be added to a student's data record which already exists on the TGISS student data file must be input using a TOA code of (R) in the master card.

Interests-Preferences-Honors must be revised by inputting the IPH card (XA) which denotes the interest-preference-honor data field to be revised. Example: to revise the fourth IPH block on a student's data record the IPH block input must be on card 4A.

Health Profile data must be input in its entirety when revised (card 0B).

3. Absence data will be added to the student data record by using card 0C with a blank TOA in column 78.
4. Current schedule will be added to the student data record by using card 0D with a blank TOA in column 78.
5. Nine-week student grades will be added to the student data record by using card 0E with a blank TOA in column 78.

IV. *Error Messages and Related Corrections*

The input verification program will print an error list of TGISS transactions input to the system. The error messages and their related corrections are as follows:

A. 'Student ID Number Field is Blank'

The student ID number field is blank and the card on which the error occurs will not be put on the TGISS student data file. The card should be corrected and re-input with a master card (01) with a TOA code of R. If the error occurred on a master card none of the related student data will be put on the student data file.

B. 'Incorrect Card Code'

The card code field is blank or contains an incorrect card code. The card on which the error occurs will not be put on the TGISS student data base and should be corrected and re-input with a master card (01) with a TOA code of R. If the error occurred on a master card none of the related student data will be put on the student data file. The card should be corrected and all the related data re-input.

C. 'Student Name Field is Blank'

The student name field on the master card is blank and no data related to this student will be put on the student data file.

The error should be corrected and the master card (01) and all data cards related to this student should be re-input.

D. 'Credit Field is Blank - Credits Must Be 0 or Value'

A credit field in a course input on the card printed out is blank. The credit field has been zeroed. If the credit field should contain a value, the erroneous course block must be re-input on the appropriate card preceded by a master card with a TOA code of R.

E. 'Course Grade is F - If Entered Twice Revise Data'

The special condition described in Section III.E. could exist and

the related data cards which contain this student's courses should be checked for the described error.

V. *Terminal Identification Program*

The terminal identification program (TERID) is a card to disk program which builds an ISAM data file (DSNAME = AUTHRZ) containing records which identify the 2260 terminals to the FASTER sign-on and sign-off routines. The terminal-ID data records contain a status byte which is used to denote whether a terminal is properly signed on or not. The present file contains ten possible terminal ID's, TR01 through TR10. If more than ten terminals are placed on-line to the FASTER system, additional terminal ID's must be added to the system. This can be accomplished by:

- A. Assigning terminal ID's to the 2260's to be put on line.
- B. Adding these terminal ID's to the data deck which follows the TERID program.
- C. Scratching and recreating the AUTHRZ (DSNAME) ISAM data set by running the TERID program.

VI. *Counselor Identification Program*

The counselor identification program (CONID) is a card to disk program which builds an ISAM data file (DSNAME = CNSLID) containing records which identify the authorized counselors to the FASTER sign-on routine. Counselor social security number and name must be included in the counselor ID file (DSNAME = CNSLID) before he can properly sign on a 2260 terminal. The FASTER sign-on routine compares the inquiry social security number with the social security numbers on the data file before setting the terminal ID status byte. On a no

match comparison the status byte will not be set and the terminal use cannot access data on the TGISS data file.

To add authorized users to the CNSLID (DSNAME) file:

- A. Add data cards with the user's social security number and name to the data deck which follows the CONID program.
- B. Scratching and recreating the CNSLID (DSNAME) ISAM data set by running the CONID program.

PART FOUR

TGISS USERS GUIDE

TGISS USERS GUIDE

I. Introduction

The TGISS on-line information retrieval system for use in the Bartlesville Public Schools has been designed and implemented to enable counselors to extract student data from the master file in an efficient and rapid manner utilizing the remote CRT and 1053 printer. In addition, the TGISS System provides for security checking before access to the student data file is permitted. In order to satisfy the security mechanism of TGISS the counselor must sign-on with his security number before the CRT can be used for inquiry to the student data base. After the counselor has properly signed-on with the TGISS System, he can then proceed to extract selected student data using the inquiry codes defined in the next section.

The security procedure implemented for the TGISS System also requires that the remote CRT be signed-off during idle periods of system use. Signing off the CRT prevents unauthorized use or access of the student data file.

The following section describes the valid inquiry codes and their use.

II. TGISS System Usage

The TGISS security procedures and student data access are affected through the use of the valid inquiry codes defined below.

SGON/soc.sec. #	Sign On
SGOF	Sign Off

HLTP/stu #	Health Profile
TR78/stu #	7th & 8th Grade Transcript
TRAN/stu #	High School Transcript
OGPA/stu #	Overall Grade Point Averages
SDTS/stu #	Standard Test Scores
GRDT/stu #	Grade Trends
GPAS/stu #/quarter*	Grade Point Averages
CURS/stu #	Current Schedule
WRKX/stu #	Work Experience
HLRD/stu #	Health Record
IPHS/stu #	Interests, Preferences, Honors
GNRL/stu #	General Information

Each inquiry must be preceded by a start character, which is generated by depressing the Shift and Start keys. Each inquiry must end with an EOB character, which is generated by depressing the Shift and Enter keys on the CRT keyboard.

The first inquiry used by the counselor should be the Sign On (SGON) transaction. The counselor simply enters the characters SGON and a slash (/) followed by his social security number in nine (9) consecutive digits, provided that the CRT has been properly signed off by any prior usage. If a sign on attempt is made and the set is already signed on, an error message indicating an improper sign on attempt will be displayed on the 2260 CRT. After the system acknowledges a proper sign on, the counselor is free to use the standard inquiry codes for access to the student data file.

*A number 01-16 should appear in this field to indicate which quarter grade point averages are requested. 01=1st quarter of freshman year and 16=last quarter of senior year.

If the counselor wishes to send the response from an inquiry directly to the 1053 printer, he can do so by following the student number in the inquiry by a slash (/) 1053; i.e., SDTS/100530/1053 would send the output directly to the 1053 bypassing the 2260 CRT. In the case of the GPAS inquiry the following would send the response to the 1053: GPAS/001600/03/1053. This inquiry would send information on grade point averages for student 001600 for the third quarter of his high school career to the 1053 printer.

However, it is possible to have the inquiry response displayed at the CRT and then printed on the 1053 by simply depressing the Shift and Print key on the CRT when the response arrives at the 2260. This feature enables the counselor to validate or inspect the information before obtaining a hard copy of same.

There are two (2) transactions in the TGISS inquiry list that require paging of the information due to the amount of data to be displayed at the remote device. These are TR78 and TRAN. Subsequent pages of information can be retrieved by using a special inquiry code, P, followed by a slash (/) and the desired page number. Thus, after the first page of information has been displayed on the 2260, the second page for the high school transcript can be displayed by utilizing the following inquiry: P/2. If there are three pages of information for TRAN, the third page can be retrieved and displayed by the inquiry code: P/3. In addition, it is possible to go back and pick up the first page or the second page after examining the second or third pages.

The final inquiry submitted to TGISS during a counseling session should be the Sign Off transaction. This inquiry code inhibits further

retrieval of information from the TGISS student file until the CRT is once again signed on with the use of the SGON inquiry code.

III. *Summary*

The preceding information outlines the proper usage of the TGISS on-line information retrieval system. For further information on the inquiry codes and subsequent response formats the user is referred to the TGISS Functional and External Specifications document.

It is important that the user of the TGISS System be aware of the built in security mechanisms and use the security procedure properly. As mentioned before, this procedure will prevent unauthorized use of the system and help provide for the integrity of the student data base.

IV. KEYWORD DICTIONARY

<i>Word</i>	<i>Definition</i>
1. TGISS	Total Guidance and Information Support System
2. FASTER	Filing and Source Data Entry Techniques for Easier Retrieval - IBM system of data access and retrieval utilizing a Macro language
3. CENTRAL SITE	Computer site - defined presently as Oklahoma State University computer center at Stillwater, Oklahoma
4. CRT	Cathod Ray Tube - 2260 type display
5. UCL	User command language - a set of inquiries to be used by the counselors in accessing and retrieving student data
6. ISAM	Indexed sequential access method - an IBM software function to store and retrieve data on direct access devices
