

DOCUMENT RESUME

ED 038 268

24

RE 002 716

AUTHOR Siegel, Alexander W.; Vance, Billie J.
TITLE Visual and Haptic Dimensional Preference: A
Developmental Study.
INSTITUTION Pittsburgh Univ., Pa. Learning Research and
Development Center.
SPONS AGENCY Office of Education (DHEW), Washington, D.C. Bureau
of Research.
REPORT NO WP-51
BUREAU NO BR-5-0253
PUB DATE 69
CONTRACT OEC-4-10-158
NOTE 26p.

EDRS PRICE MF-\$0.25 HC-\$1.40
DESCRIPTORS Discrimination Learning, Grade 1, Grade 3, *Haptic
Perception, Intermode Differences, Kindergarten,
*Perceptual Development, Preschool Children,
*Response Mode, *Visual Perception

ABSTRACT

Dimensional preference tasks in both visual and haptic modalities with three dimensional stimuli varying in form, size, color, or texture were presented to 64 children. There were 16 subjects at each of four grade levels: preschool, kindergarten, grade 1, and grade 3. On each trial, the subject was presented three stimuli and asked to tell the examiner which two were the same. The pattern of preference scores was essentially the same in both visual and haptic tasks. On both tasks, all age groups, except for the preschoolers, showed marked form dominance. Form was especially salient for the kindergarteners and seemed to decrease in salience after that point. Preschoolers showed no clear dimensional preference. However, color or texture preference was relatively low at all ages. The importance of type of stimuli and method of presentation used in assessing dimensional preference is discussed in an attempt to account for the discrepancies between the results of this and previous studies. Tables, charts, and references are included. (Author/WB)

U.S. DEPARTMENT OF HEALTH, EDUCATION
& WELFARE
OFFICE OF EDUCATION
THIS DOCUMENT HAS BEEN REPRODUCED
EXACTLY AS RECEIVED FROM THE PERSON OR
ORGANIZATION ORIGINATING IT. POINTS OF
VIEW OR OPINIONS STATED DO NOT NECESS-
SARILY REPRESENT OFFICIAL OFFICE OF EDU-
CATION POSITION OR POLICY

ED038268

BR-3-6253
10-51
11-51
12-51

VISUAL AND HAPTIC DIMENSIONAL PREFERENCE:

A DEVELOPMENTAL STUDY

Alexander W. Siegel and Billie J. Vance

Learning Research and Development Center

University of Pittsburgh

Published by the Learning Research and Development Center supported in part as a research and development center by funds from the United States Office of Education, Department of Health, Education, and Welfare. The opinions expressed in this publication do not necessarily reflect the position or policy of the Office of Education and no official endorsement by the Office of Education should be inferred.

This document has been approved for public release and sale; its distribution is unlimited. Reproduction in whole or in part is permitted for any purpose of the U. S. Government.

**VISUAL AND HAPTIC DIMENSIONAL PREFERENCE:
A DEVELOPMENTAL STUDY**

Alexander W. Siegel and Billie J. Vance

University of Pittsburgh

Abstract

Sixty-four children, 16 at each of four grade levels: Pre-school, kindergarten, first- and third-grade, were given dimensional preference tasks in both visual and haptic modalities, with three dimensional stimuli varying in form, size, and color or texture. On each trial S was presented three stimuli and asked to tell E which two were the same. The pattern of preference scores was essentially the same in both visual and haptic tasks. On both tasks, all age groups, except for the preschoolers, showed marked form dominance. Form was especially salient for the kindergarteners, and seemed to decrease in salience after that point. Although preschoolers showed no clear dimensional preference, color or texture preference was relatively low at all ages. The importance of type of stimuli and method of presentation used in assessing dimensional preference was discussed in an attempt to account for the discrepancies between the results of this and previous studies.

VISUAL AND HAPTIC DIMENSIONAL PREFERENCE:
A DEVELOPMENTAL STUDY¹

Alexander W. Siegel and Billie J. Vance

University of Pittsburgh

Dimensional dominance in children has been studied in a variety of paradigms and in both visual and haptic modalities. For the most part, however, research has concentrated on studying visual preference in a matching-to-sample task. In one of the earliest studies, Brian & Goodenough (1929) studied the performance of two- to 18-year-old Ss using both two- and three-dimensional stimuli. Their results indicated two age shifts in the dimensional dominance: A shift from form to color dominance at three years, and a shift back to form at six years. Suchman and Trabasso (1966) used only two-dimensional stimuli in a similar task. They found a shift from color to form dominance at a median age of 4 years 2 months, and also found that when color cues were made less discriminable, younger Ss tended to match on the basis of form. Corah (1966) studied preschool Ss (mean age = 4 yr., 6 mo.) and found that when familiar symmetrical stimuli were used, Ss matched on the basis of form; when asymmetrical stimuli were used, however, Ss resorted to matching by color. Mitler and Harris (1969) used a card-sorting task to study the preferences of children aged 5 yr., 3 mo. to 9 yr., 2 mo. The stimuli varied on color, number, and form. Children at all age levels sorted by (i. e., preferred) form.

Siegel

The most recent and comprehensive series of studies of dimensional dominance was done by Gliner, Pick, Pick, and Hales (1969). Kindergarten (ages 5 yr., 7 mo. to 6 yr., 0 mo.) and third-grade Ss (8 yr., 6 mo. to 8 yr., 11 mo.) were given visual and haptic preference and discrimination tasks, in which the planometric stimuli varied on form and texture. After S reached criterion on a discrimination (e.g., rough circle, correct; smooth ellipse, incorrect), the cues were put in conflict in the subsequent test (e.g., the test stimuli were now rough ellipse and smooth circle), and S had to choose the one he thought was correct. Although discriminability of the two dimensions was equal, third-graders chose on the basis of form in both visual and haptic tasks. Kindergarteners, however, chose on the basis of form in the visual task, but chose on the basis of texture in the haptic task. In another haptic experiment, texture cues were reduced (i.e., the difference between the two textures was minimally discriminable), and kindergarten Ss shifted their basis of response from texture to form. However, when form cues were made less discriminable, third-graders maintained their form preference.

These studies have all used relatively indirect and complicated methods to assess dimensional preference, and in fact, many results (and discrepancies between results) might be an artifact of the procedure involved. In the present study, after it was ascertained that S knew what the word "same" meant, he was simply presented three stimuli and asked which two were the same.

Three-dimensional stimuli were used in the present experiment for two reasons: (a) Three-dimensional stimuli seem to have

Siegel

more "ecological validity." (b) The youngest Ss available to us were somewhat older than those used in previous studies (the mean age of our preschool Ss was 5 yr., 0 mo.), and since form preference was known to be relatively strong at this age, we attempted to maximize color preference. (According to Brian and Goodenough [1929], color preference was relatively stronger for three- than for two-dimensional stimuli.)

Unlike the Gliner et al. study (1969), a within-Ss design was used to allow assessment of the degree of inter-modal correspondence in dimensional dominance. For the purposes of this study, it was assumed that texture was the haptic analog of color.

In Gliner et al.'s haptic task, Ss were presented the stimuli successively, whereas stimuli were presented simultaneously on the visual task. The discrepancy between their visual and haptic results might have been a function of this difference. In both the visual and haptic tasks in the present study, stimuli were presented simultaneously.

Based on the findings of the previous studies, it was predicted that all Ss (with the possible exception of the preschoolers, who should show mixed or color dominance) would show form dominance in the visual task. However, in the haptic task, it was expected that texture would be dominant for preschoolers, and possibly for kindergarteners, with a shift to form dominance occurring before the third-grade.

Siegel

Method

Subjects

Sixteen children at each of four grade levels (preschool, kindergarten, first, and third) participated in the experiment. All children attended public pre- or elementary schools in Pittsburgh, came from predominantly middle socioeconomic backgrounds, and were average or above in intelligence. Mean ages in years and standard deviations in months were: Preschool (5 yr., 0 mo. SD = 3.5 mo.), kindergarten (5 yr., 7 mo. SD = 2.3 mo.), first-grade (6 yr., 11 mo. SD = 3.0 mo.), and third-grade (8 yr., 8 mo. SD = 4.9 mo.). In each age group there were eight boys and eight girls.

Apparatus

Apparatus for the visual task was a wooden tray, 17 1/2 inches long by 4 inches wide by 3/4 inch thick. There were three stimulus wells spaced in a horizontal line on the tray, with their centers 5 inches apart. (Each well was constructed so that it would hold any of the various stimuli and allow S to lightly touch or feel a stimulus without it moving).

In the haptic task this tray was presented to the child through the back of the apparatus shown in Figure 1. This box

 Insert Figure 1 about here

Siegel

was constructed of quarter-inch plywood and was 24 inches high at E's side of the box, 24 inches wide, and 12 inches deep. The front of the box was a 12-inch by 24-inch panel, joined at the top by a 17-inch panel which sloped upward to E's side. Two 4-inch-diameter holes were cut into the front panel; their centers were 12 inches apart and 6 inches from the bottom of the panel. An elastic knit cuff was set in each hole so that S could insert his hand (up to the elbow) and feel the stimuli in any way that he chose. E's side of the apparatus was open so that E could arrange the stimuli, present the stimulus tray, observe the manner in which S explored the stimuli, and note when S made his "choice" response. The height of the stimulus tray could be adjusted to a level comfortable for each S.

Stimuli

The eight stimuli for the visual task were spheres and cubes differing in size and color (red and blue). The large cubes were $1 \frac{3}{4}$ inch, and the small cubes were $1 \frac{1}{4}$ inch on a side. The large spheres were $2 \frac{1}{16}$ inch, and the small spheres were $1 \frac{9}{16}$ inch in diameter. Although the diameters of the spheres were greater than the edges of the respective cubes, these stimuli were perceived as being the same size both by children and adults.

The eight stimuli for the haptic task were the same size and shape as those for the visual tasks, but differed in texture. The surfaces of the smooth stimuli were unfinished, sanded wood; those of the rough stimuli were 60-grit Armour sandpaper. The data of Gliner et al. (1969) indicated that these two textures were discriminable by 100 percent of their Ss.

Siegel

Procedure

All Ss were tested individually. E seated S opposite him at a desk, told S that he would play some games, and that when the games were finished he could choose any one of a number of small prizes displayed on a prize board. All Ss were given both the visual and haptic tasks; half of the Ss in each Age by Sex subgroups were given the visual task first, and half were given the haptic task first.

Ss were given the following instructions for each task: "The first (next) game we're going to play is one where you'll look at (feel) things. See (feel) these three things?" (S was shown three wooden letters, two "C"s and an "I" visually and two "T"s and one "S" haptically.) "I want you to tell me which two are the same." (No S had any difficulty with this pretest, designed to determine whether he knew what "same" meant). "Good! Now, we're going to play a game using different things, like these." (E held up a small red sphere and a large blue cube in the visual task, or put S's hands on a small smooth cube and a large rough sphere in the haptic task). "Some of the things will be red (smooth) and some will be blue (rough); some will be round and some will be square; some will be big and some will be small." (E held up the appropriate object, or made sure that S felt the appropriate object, as he named each feature). "I'm going to show (you're going to feel) three things at a time and I want you to point to (leave your hands on) the two that are the same. This isn't a test, it's a game. I won't tell you whether or not you're right or wrong because there

Siegel

are no rights or wrongs. I just want you to point to (feel all three things and leave your hands on) the two things that are the same. Do you understand"? (If E doubted S's comprehension of the instructions, he asked S to repeat them). Occasionally, during the haptic task, it was necessary to guide S's hands to make sure that he felt all three stimuli before responding, but after the first two or three trials S was allowed to explore the stimuli in whatever fashion he chose.

In both visual and haptic tasks, S was given 20 trials, on each of which he was given a choice of matching on one of two or three stimulus dimensions. For each S, four of the 20 trials represented a color (texture)-form choice; four represented a color (texture)-size choice; four represented a form-size choice; and the remaining eight represented a choice among all three dimensions. For example, the child was presented three stimuli: (a) large red sphere, (b) small blue sphere, and (c) large blue cube. If S designated that (a) and (b) were the same, form was considered to be S's preferred dimension in this comparison; if S designated (b) and (c) as the same, color was preferred; and if (a) and (c) were designated the same, then size was preferred. If, on a two-dimension comparison trial in which (a) large red sphere, (b) large blue sphere, and (c) large red cube, S chose (a) and (b) as being the same, this was a form choice; a choice of (a) and (c) was a color choice; and a choice of (b) and (c) was an error since there was no dimensional basis for this response. Only six of the children made one error, and only one made two errors.

For both visual and haptic tasks, the 20 stimulus triads were selected so that (as nearly as possible) each of the eight stimuli

Siegei

appeared equally often, and equally often in each position. Two random orders for presentation were generated for both tasks, and half of the Ss within each subgroup received stimulus triads in each order. Thus, the experimental design was a 4 (Age) X 2 (Sex) X 2 (Order of Testing) factorial design with 4 Ss in each cell.

Results

On each task, two preference measures were computed for form, color/texture, and size. The primary preference score for a particular dimension was simply the number of choices made on the basis of that dimension in the eight triads in which S was given a choice of all three dimensions. The maximum possible score for a given dimension (and thus, the sum of all three dimensions) was eight. A secondary measure was computed by combining the number of particular dimension choices on the eight 3-choice trials, and the eight 2-choice trials in which that dimension was present. This type of score is similar to that used in previous studies of color-form dominance.

Four (Age) X 2 (Sex) X 2 (Order) factorial analyses of variance were performed on both types of visual and haptic preference scores. For all dimensions, analyses of primary and secondary measures yielded identical significant main effects and interactions. In addition, correlations computed between the primary and secondary measures were in every case highly significant, both overall and for each age group separately ($r^2 = .73$, $df = 14$, $p < .001$), with a majority of the correlations being in the .90's. Thus, since the primary preference score is the purest measure of preference

Siegel

(being based solely on trials where all three stimulus dimensions are present), all further analyses and discussion are based on it.

Analyses of Visual Preferences

The number of Ss in each age group showing consistent dimensional dominance (defined as making at least 6 out of 8 choices on one dimension) is presented in Table 1. (An S was classified as

Insert Table 1 about here

"inconsistent" if he made less than six choices on the basis of one dimension). Although it appears that there were fewer preschoolers than kindergarteners who were "form dominant", this difference was not significant ($\chi^2 = 3.91$, $df = 3$, $p > .10$). Although a measure like "number of form dominant Ss at each age level" is very rough and imprecise, such a measure has often been employed as one of the primary bases on which developmental trends have been inferred. It is apparent that a more fine-grained analysis is appropriate.

Separate 4 (Age) X 2 (Sex) X 2 (Order) analyses of variance were performed on the form, color and size preference scores. All three analyses yielded significant main effects of Age ($F^2 = 2.86$, $df = 3/48$, $p < .05$). The mean visual preference scores for each age group are presented in Table 2; Scheffe (.05) confidence inter-

Insert Table 2 about here

Siegel

vals were computed for each. As can be seen in Figure 2, form

 Insert Figure 2 about here

preference was significantly greater for kindergarten than for both preschool and first-grade Ss. Color preference, on the other hand, was significantly greater for preschool Ss than for either kindergarten or first-grade Ss. For size preference, only the decrease from kindergarten to first-grade was significant.

Comparisons (t tests for correlated means) were computed to determine relative dimension preference for each age group. For the three oldest age groups, there was a significant preference for form over size and for form over color ($t = 3.04$, $df = 15$, $p < .01$). The difference between form and size was only barely significant for the preschoolers ($t = 2.35$, $p < .05$). There were no significant differences between color and size preference scores.

In addition, analysis of the form preference scores yielded a significant main effect of Sex ($F = 5.12$, $df = 1/48$, $p < .05$), indicating that the mean form preference score of the girls (6.41) was greater than that of the boys (4.94). For none of the three analyses were any other main effects of interactions significant ($F < 1.19$, $df = 1/48$, $p > .10$).

Analyses of Haptic Preferences

The number of Ss who chose on the basis of the same dimension in 6 out of 8 3-choice trials is presented in Table 1. In line

Siegel

with the visual data, the difference in number of form dominant children at each age level was not significant ($\chi^2 = 5.60$, $df = 3$, $p > .10$).

Again, separate 4 (Age) X 2 (Sex) X 2 (Order) analyses of variance were performed on the form, texture, and size preference scores. All three analyses yielded significant main effects of Age ($F \geq 3.27$, $df = 3/48$, $p < .05$). The mean preference scores for each age group are presented in Table 2; Scheffe (.05) confidence intervals were computed for each preference score. Although the haptic results (presented in Figure 3) appear remarkably similar to

 Insert Figure 3 about here

the visual results, only two between-age comparisons were significant: Form preference was greater and size preference was less for the kindergarteners than for the preschoolers.

Again, t tests (for correlated means) were computed to determine relative dimension preference for each age group. As in the visual data, for the three oldest age groups there was a significant preference for form over size and for form over texture ($t \geq 2.95$, $df = 15$, $p < .01$). The preference for form over size for the preschoolers, and the preference for texture over size for the first- and third-graders were also significant ($t \geq 2.47$, $p < .05$).

Visual-Haptic Comparisons

Significant Pearson product-moment correlations were computed for all S s between visual and haptic form, color/texture, and

Siegel

size preference scores ($r = +.40, +.25, \text{ and } +.37$, respectively, $df = 62, p < .05$). When these correlations were computed separately for each age group, however, only the form and color/texture preference scores for the third-graders, and the size preference scores for the preschoolers were significantly related ($r = +.69$), $df = 14, p < .01$). It was impossible to obtain meaningful correlations for the kindergartener; since in the haptic task, every choice made by every S was a form choice.

Separate analyses of variance were performed on the form, color/texture, and size preference scores, with visual-haptic tasks as the repeated measure: No main effect nor any interaction was significant ($F < 1.00$). Thus, there appeared to be no significant discrepancies between Ss' visual and haptic preference scores for any dimension.

Discussion

The main finding of the study was that children showed clear-cut visual and haptic form dominance from age 5-7 years on. Thus, visual form dominance was found at a later age than in the studies by Corah (1966) and by Suchman and Trabasso (1966), who found clear-cut form dominance at 4-2 years and 4-6 years, respectively. However, 3-dimensional stimuli were used in the present study, while 2-dimensional stimuli were used in the others. The finding that form dominance appears later when three-dimensional stimuli are used is consistent with Brian and Goodenough's (1929) data: For Ss given both two- and three-dimensional stimuli (in separate tasks), more color choices and fewer form choices were obtained when three-

Siegel

dimensional stimuli were used. It would seem that if form preference is harder to elicit when S is given three-dimensional stimuli, then it is likely that form dominance would appear at a later age when three-dimensional stimuli are used.

Both Gliner et al. (1969) and our study found visual form dominance at age 5-7 years. However, the present study also found haptic form dominance at 5-7, while Gliner et al. found haptic form dominance only in their third-grade Ss. Both studies used simultaneous presentation of stimuli and permitted free exploration in the visual task. However, Gliner et al. used planometric stimuli, while the present study used three-dimensional stimuli. Apparently, this difference in type of stimuli has no effect on visual dimensional dominance for Ss 5-7 years or older.

In our haptic task, stimuli were presented simultaneously, while Gliner et al. used a successive presentation procedure. Thus, the discrepancy in results between the two haptic tasks and between Gliner et al.'s haptic and visual tasks may have been due to this difference in method of stimulus presentation, or because planometric stimuli are not functionally the same in the visual and haptic modalities. No group of Ss showed color dominance. Preschoolers (5 yr., 0 mo.) in fact, appeared to be in a mixed phase with no dimension being significantly preferred over another. Perhaps these 5-year olds were in a transition phase from color to form dominance. The significant decrease in color preference and the significant increase in form preference from 5 yr., 0 mo. to 5 yr., 7 mo. offers some support for such an interpretation.

Siegel

No support was found for Gliner et al.'s (1969) hypothesis that texture has special salience for young Ss. For no age group was texture preference greater than form preference, and texture preference was significantly greater than size preference only for the two older age groups. (As has been documented by Suchman and Trabasso [1966], the dimension of size was relatively non-salient, i. e., size preference was very low at all ages).

It is evident that form is particularly salient for kindergarten Ss, both visually and haptically. It was expected that form preference would increase steadily from preschool to third-grade, or reach and stay at an asymptotic level at one of the ages studied. Although form preference scores did increase significantly from preschool to kindergarten (asymptote), they decreased from kindergarten to first-grade. It is hard to explain why form should be so salient for kindergarten Ss. Although the correlations between visual and haptic scores for form, color/texture, and size were all significantly positive, all three were relatively low and not very different from one another. In fact, the highest inter-task correlation (form) accounted for only 16 percent of the variance. However, analyses of variance for all three scores (with task as the repeated measure) indicated that the hierarchies of dimensional preference, both for all Ss and for each age group were essentially the same in both visual and haptic tasks. Thus, there is insufficient evidence to determine whether texture is the direct haptic analog of color. In view of this, it seems best to follow the procedure of Gliner et al.: Texture should be used in both visual and haptic tasks, since it is, at least, the same physical dimension.

Siegel

In summary then, it would seem that age differences in form dominance are affected by the type of stimuli used (two-dimensional, planometric, or three-dimensional), the method in which stimuli are presented (simultaneous or successive), or both. In addition to these two factors, differences in the dimensional preference hierarchy can be produced when stimuli are made less familiar (Corah, 1966), or less discriminable along a given stimulus dimension (Gliner et al., 1969). More research must be done to determine what other kinds of stimulus variation can change the child's dimensional preference hierarchy. Varying the relative novelty of form, color, and texture cues, and consequently determining how such changes affect dimensional dominance patterns seems to be a logical step.

Siegel

References

- Brian, C. R., & Goodenough, F. L. The relative potency of color and form perception at various ages. Journal of Experimental Psychology, 1929, 12, 197-213.
- Corah, N. L. The influence of some stimulus characteristics on color and form perception in nursery-school children. Child Development, 1966, 37, 205-211.
- Gliner, C. R., Pick, A. D., Pick, H. L., & Hales, J. J. A developmental investigation of visual and haptic preferences for shape and texture. Monographs of the Society for Research in Child Development, 1969, 34, Serial No. 130.
- Mitler, M. M., & Harris, L. Dimension preference and performance on a series of concept identification tasks in kindergarten, first-grade, and third-grade children. Journal of Experimental Child Psychology, 1969, 7, 374-384.
- Suchman, R. G., & Trabasso, T. Stimulus preference and cue function in young children's concept attainment. Journal of Experimental Child Psychology, 1966, 3, 188-198.

Siegel

Footnote

¹The research reported herein was sponsored by the Personnel and Training Branch, Psychological Sciences Division, Office of Naval Research, and the Learning Research and Development Center, University of Pittsburgh. We wish to thank the principals and teachers at Chartiers Preschool and Colfax Elementary School in Pittsburgh for their helpful cooperation in this study. The authors also express their appreciation to Joseph Albert and Nancy Henry who assisted in this project, and to David Katsuki for his assistance in the construction of the stimuli and apparatus.

Table 1

Number of "Dominant" Ss in Each Age Group

<u>Age Group</u>	<u>Visual Task</u>				<u>Haptic Task</u>			
	<u>Form</u>	<u>Color</u>	<u>Size</u>	<u>Inconsistent</u>	<u>Form</u>	<u>Texture</u>	<u>Size</u>	<u>Inconsistent</u>
	<u>Dominant Dimension</u>				<u>Dominant Dimension</u>			
Preschool	7	5	2	2	6	3	3	4
Kindergarten	15	0	0	1	16	0	0	0
First-Grade	8	0	3	5	8	2	0	6
Third-Grade	12	1	1	2	10	2	0	4

Table 2

Means and S. D. s of Preference Scores for the Four Age Groups
(8 is Maximum Possible)

<u>Age Group</u>	<u>N</u>	<u>Visual Preference</u>			<u>Haptic Preference</u>							
		<u>Form</u>	<u>Color</u>	<u>Size</u>	<u>Form</u>	<u>Texture</u>	<u>Size</u>					
Preschool	16	3.88	3.00	2.94	1.12	2.12	4.31	3.11	2.12	2.80	1.56	2.36
Kindergarten	16	7.75	1.00	0.25	1.00	0.00	8.00	0.00	0.00	0.00	0.00	0.00
First-Grade	16	5.00	2.96	0.94	1.34	2.06	2.71	5.68	2.75	1.94	0.38	1.08
Third-Grade	16	6.06	2.54	1.06	1.65	0.88	1.93	5.75	2.40	2.06	0.19	0.54
All Ss	64	5.67	2.91	1.31	2.10	1.02	2.07	5.94	2.70	1.53	0.53	1.44
<hr/>												
Scheffe (.05) Confidence Interval		2.67	2.05	2.06	2.55	2.32	1.48					

Siegel

Figure Captions

Figure 1. Apparatus for haptic task.

Figure 2. Mean visual preference scores for each of the various age groups.

Figure 3. Mean haptic preference scores for each of the various age groups.

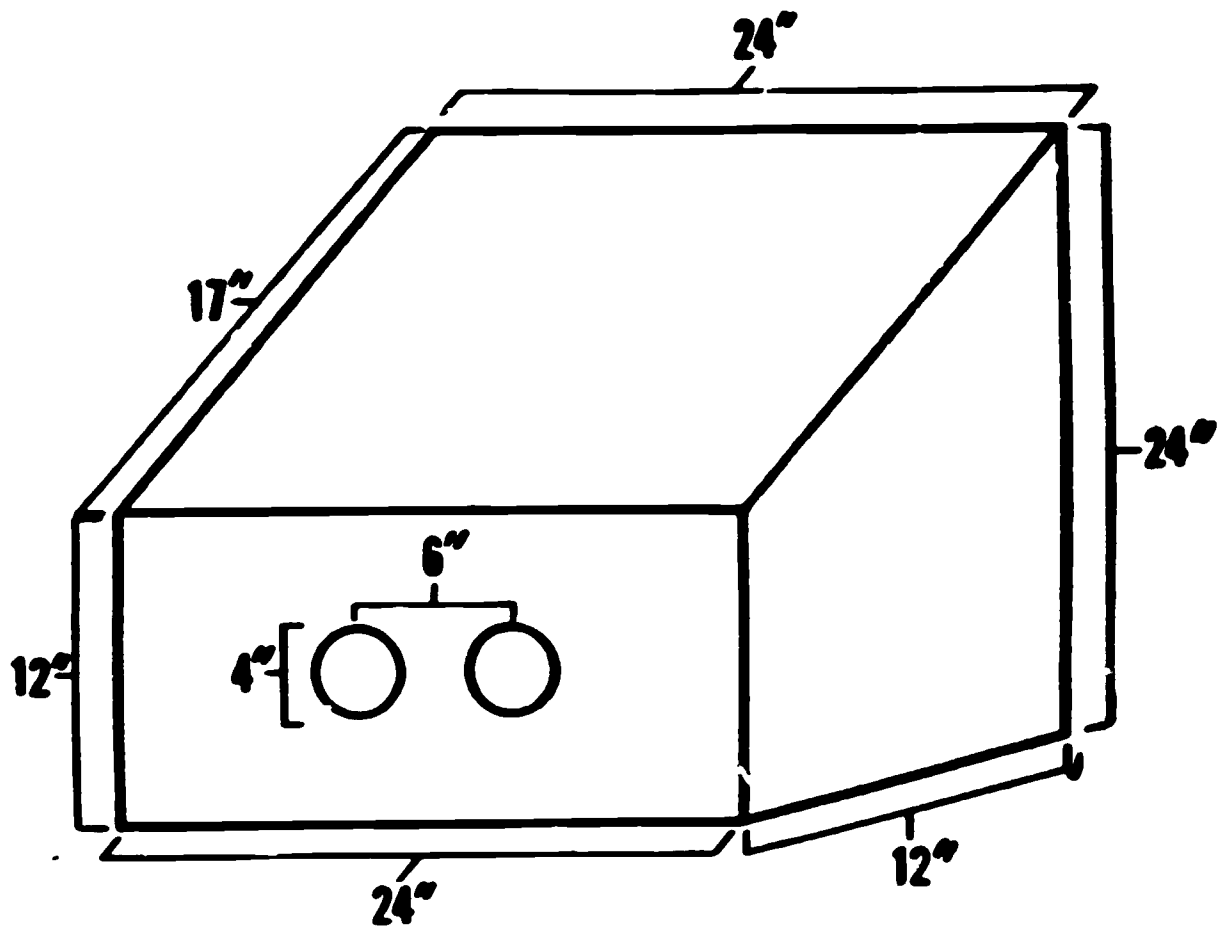

Front and Side View

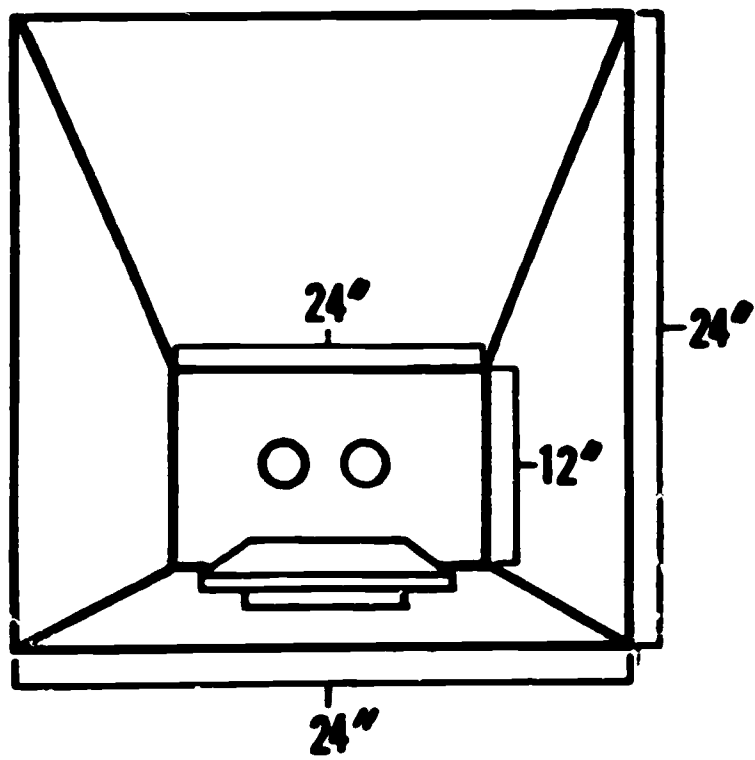

Rear View

Figure 1. Apparatus for haptic task.

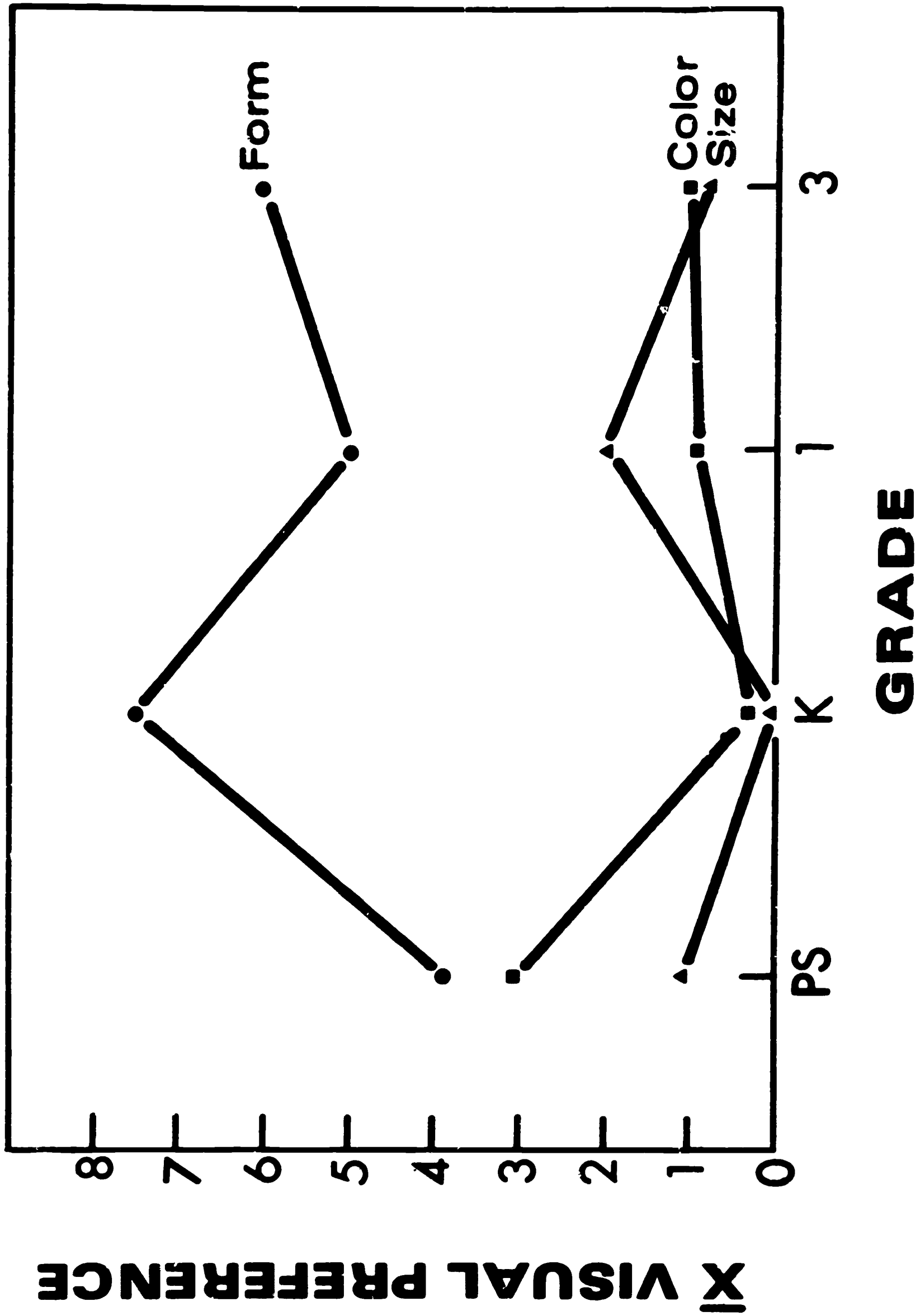

Figure 2. Mean visual preference scores for each of the various age groups.

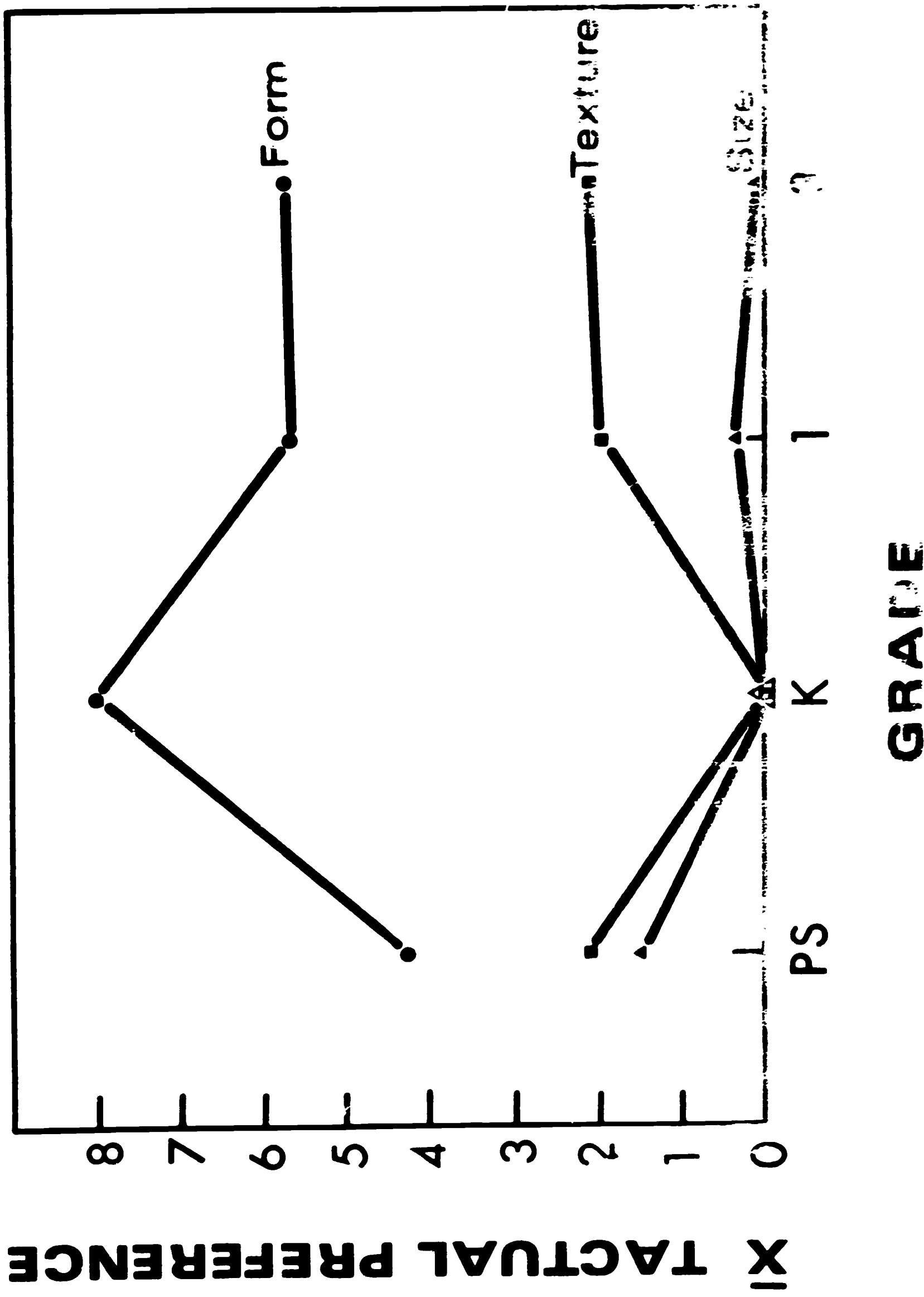

Figure 3. Mean haptic preference scores for each of the various age groups.