

DOCUMENT RESUME

ED 037 950

EF 004 130

AUTHOR Haviland, David S.
TITLE University Facilities for Electronic Resource Systems.
INSTITUTION Rensselaer Polytechnic Inst., Troy, N.Y. Center for Architectural Research.
PUB DATE Aug 67
NOTE 147p.; The report of an architectural research project undertaken for the Office of Facilities Programming and Research, State University of New York, by the staff of the Center for Architectural Research
AVAILABLE FROM Center for Architectural Research, Rensselaer Polytechnic Institute, Troy, N.Y.
EDRS PRICE MF-\$0.75 HC Not Available from EDRS.
DESCRIPTORS *Audiovisual Centers, Building Design, *Computer Based Laboratories, Controlled Environment, Educational Technology, Electronic Equipment, Environmental Criteria, Environmental Influences, *Facility Guidelines, *Facility Utilization Research, Interior Space, Lighting, Physical Design Needs, Planning, Space Utilization, *Universities, Use Studies

ABSTRACT

A report on electronic media investigates and reveals the basis for and the use of electronic resource systems on the university campus. Computer system facilities, environments, and equipment guidelines and criteria are given with the what, why and how aspects of the resource systems. The functions and categories of the university electronic resources available are described with regard to planning and designing facilities and programs for them. Storage and support requirements are given for computer centers, facsimile and audio-video laboratories. Specifications, diagrams, and floor plans are also given. (TG)

ED037950

UNIVERSITY FACILITIES FOR ELECTRONIC RESOURCE SYSTEMS

U.S. DEPARTMENT OF HEALTH, EDUCATION
& WELFARE
OFFICE OF EDUCATION
THIS DOCUMENT HAS BEEN REPRODUCED
EXACTLY AS RECEIVED FROM THE PERSON OR
ORGANIZATION ORIGINATING IT. POINTS OF
VIEW OR OPINIONS STATED DO NOT NECES-
SARILY REPRESENT OFFICIAL OFFICE OF EDU-
CATION POSITION OR POLICY.



The report of an architectural research project undertaken for the Office of Facilities Programming and Research, State University of New York, by the staff of the Center for Architectural Research, School of Architecture, Rensselaer Polytechnic Institute, Troy, New York.

David S. Haviland, Principal Investigator

August 1967

EF 004 130

FOREWORD

In June of 1966, the Center for Architectural Research began a study of "Facility and Equipment Needs to Meet SUNY Programs in Electronic-Based Resources and Learning" for the Office of Facilities Programming and Research, State University of New York.

The study was initiated in recognition of the fact that SUNY is undergoing an extensive expansion program, involving both the development of existing campuses and the creation of totally new ones. Parallel to this expansion is a burgeoning of instructional technology and new approaches to teaching, learning, and the use of information on the college campus. Since the architectural programming for new campus buildings must be accomplished years in advance of occupancy, a study of the new technology and its facilities implications seemed to be in order.

The first effort involved the compilation of technological data and the preparation of an interim report detailing the current state-of-the-art of educational technology. Using the results of that survey, detailed programming information was developed and is presented herein.

This report suffers from two inherent limitations which ought to be noted at the outset:

1. It cannot possibly claim to be comprehensive; new equipment and

ED037950

systems of equipment are constantly thrust onto the educational market. It does, however, represent what the writer considers to be the most significant and far-reaching developments.

2. It is not oriented to programming facilities for one particular campus. Without the establishment of campus-wide policies concerning the use of these electronic resources and systems, detailed and accurate predictions of types and sizes of spaces often becomes difficult.

The report begins by examining the functional bases for the use of electronic resources, and then presents four major resource "systems" that may be established on campus. Each resource system includes some general comments and a number of "Facility Data Sheets" giving programming data.

It is important to recognize that the Facilities Data Sheets present information about a type of area which must be provided; the determination of how many areas is the task of the individual building program.

CONTENTS

PART 1: INTRODUCTION	the functions.....	1
	the resource systems	17
PART 2: COMPUTER RESOURCE SYSTEM	introduction.....	21
	request/presentation.....	26
	DATA SHEETS A-1 TO A-6	
	storage and supply.....	30
	DATA SHEETS A-7 TO A-17	
PART 3: NON-DISTRIBUTED AUDIO-VIDEO RESOURCE SYSTEM	introduction.....	40
	presentation.....	44
	DATA SHEETS B-1 TO B-6	
	storage and support	46
	DATA SHEETS B-7 TO B-10	
PART 4: DISTRIBUTED AUDIO-VIDEO RESOURCE SYSTEM	introduction.....	48
	request/presentation.....	51
	DATA SHEETS C-1 TO C-6	
	storage and support	53
	DATA SHEETS C-7 TO C-8	
PART 5: FACSIMILE RESOURCE SYSTEM	introduction.....	55
	presentation.....	60
	DATA SHEETS D-1 TO D-3	
	storage and support	62
	DATA SHEETS D-4 TO D-7	
	appendix.....	64

FACILITY DATA SHEETS

PART 2: COMPUTER RESOURCE SYSTEM

- A-1 Keyboard and Printer Request/Presentation Area
- A-2 Keyboard and CRT Request/Presentation Area
- A-3 Keyboard and Interactive Graphic Display Area
- A-4 Keyboard, Audio and Projected Visual Display Area
- A-5 Telephone Request/Presentation Area
- A-6 Computer Terminal Areas: A Summary

- A-7 Central Equipment Areas: A Summary
- A-8 On-Line Equipment Areas
- A-9 Off-Line Equipment Areas
- A-10 Media Handling Area
- A-11 Equipment Maintenance Area
- A-12 Computer Distribution
- A-13 Central Support Areas: A Summary
- A-14 Computer "Ready" Area
- A-15 Staff Office/Work Area
- A-16 Documentation Library
- A-17 Conference/Classroom Area

PART 3: NON-DISTRIBUTED AUDIO-VIDEO RESOURCE SYSTEM

- B-1 Individual Audio Presentation/Recording Area
- B-2 Small Group Audio Presentation/Recording Area
- B-3 Individual Viewing/Listening Area
- B-4 Small Group Viewing/Listening Area
- B-5 Special Presentation/Manipulation Area
- B-6 Large Group Viewing/Listening Area

- B-7 Central Audio-Video Checkout Area
- B-8 Central Audio-Video Materials Area
- B-9 Central Audio-Video Equipment Area
- B-10 Local Audio-Video Production Area

PART 4:
DISTRIBUTED
AUDIO-VIDEO
RESOURCE SYSTEM

- C-1 Individual Audio Presentation/Recording Station
- C-2 Group Audio Presentation/Recording Station
- C-3 Individual Viewing/Listening Station
- C-4 Group Viewing/Listening Area
- C-5 Audio Laboratory
- C-6 Video Laboratory

- C-7 Ready-Stored Audio-Video Resources Area
- C-8 Audio-Video Production/Support and Distribution

PART 5:
FACSIMILE
RESOURCE SYSTEM

- D-1 Hardcopy Production Area
- D-2 Remote Hardcopy Request/Presentation Area
- D-3 Microform Presentation Area

- D-4 Microform Checkout and Circulation Control Area
- D-5 Microform Storage Area
- D-6 Microform Production Area
- D-7 Facsimile Distribution

1

INTRODUCTION :

a method of attack

Before investigating the facilities implications of electronic resource systems on the university campus, it is necessary to,

1. Investigate what happens on campus,
2. Note the electronic resources available or projected to help accomplish these functions,
3. Group the electronic resources into their generic groups or "systems",
4. Speculate on how these resource systems may be handled on different campuses or in different situations, and,
5. Finally establish planning and programming data for the housing of the functions and their electronic resource systems.

The development expressed in these five steps is an important one; it is spurious to dive directly into facilities implications until the "what", "why" and "how" aspects of the resource systems themselves are presented.

This Part of the Report seeks to accomplish, in broad terms, the first four tasks; the remaining sections will present the facilities implications of the primary resource systems identified in Part I.

the functions of the university

It is no great secret that many activities, all related in some way to the mission of the college or university, take place on its campus.* Some relate directly to the teaching-learning processes, others relate much less directly. All, however, create demands on the electronic resources and resource systems to be used on campus.

Any effort to subdivide the functions of the university is bound to raise questions; the complex interrelationships nearly defy categorization.

The following breakdown of university functions is used for discussion purposes, and is not in any way intended to be "final" or "complete":

1. EXPOSITION OF INFORMATION, or the direct communication of data from person (or mediating device) to person. The principals in the communication process may be the student, the teacher, the researcher or the administrator.
2. SEARCH AND RETRIEVAL OF INFORMATION, or the placing and fulfilling of requests to some information store. Any of the persons above may be involved; the information store may

*"Campus" will be used in this report to designate one discrete unit of the State University of New York - this unit may or may not possess a "campus" in the traditional sense.

be very crude (a handwritten set of notes), partially formalized (a book), or very highly formalized (a computer storage bank). Likewise, the method of search and retrieval may or may not demand the intervention of electronic means.

3. **MANIPULATION OF INFORMATION**, or the need to act on, modify, purge, or otherwise "use" retrieved data. The user may be any of the above, and he may want to restore the data to its original location when he is done. This includes the highly complex updating of research data, the administrator's need to change enrollment data, or the student's need to compare his voice against a pre-recorded sound track in language training.
4. **EVALUATION OF PERFORMANCE**, or the need to detect performance, evaluate it against some norm or goal, create a diagnostic and communicate that diagnostic to the person or thing evaluated. While this function necessarily emphasizes student evaluation, many other evaluations are also taking place on the campus (evaluation of teaching performance; evaluation of usefulness of materials in the library; evaluation of research results).
6. **GENERAL ADMINISTRATION**, or the need to allocate and account

for all the resources (people, materials, money, time, space) owned or used by the university.

It is obvious that these functions cannot occur in isolation from one another. The "model" presented on page 5 portrays one attempt at showing their interrelationships; however crude, it tells us that it will be difficult to discuss one without at least considering the others.

exposition of information

It is easiest - although not entirely accurate - to think of "teaching" as the exposition of information from teacher to student. All persons on the college campus, however, are constantly engaged in the exposition of information to each other; the student makes a class presentation, the teacher expounds on the steps of the student union, the president goes on the air to explain a new policy, and the researcher presents his latest findings at a session of his peers.

A great deal of exposition takes place without the intervention of electronic resources: the human voice and the printed page (manually retrieved and used) have been and are destined to persevere as the prime techniques for exposition.

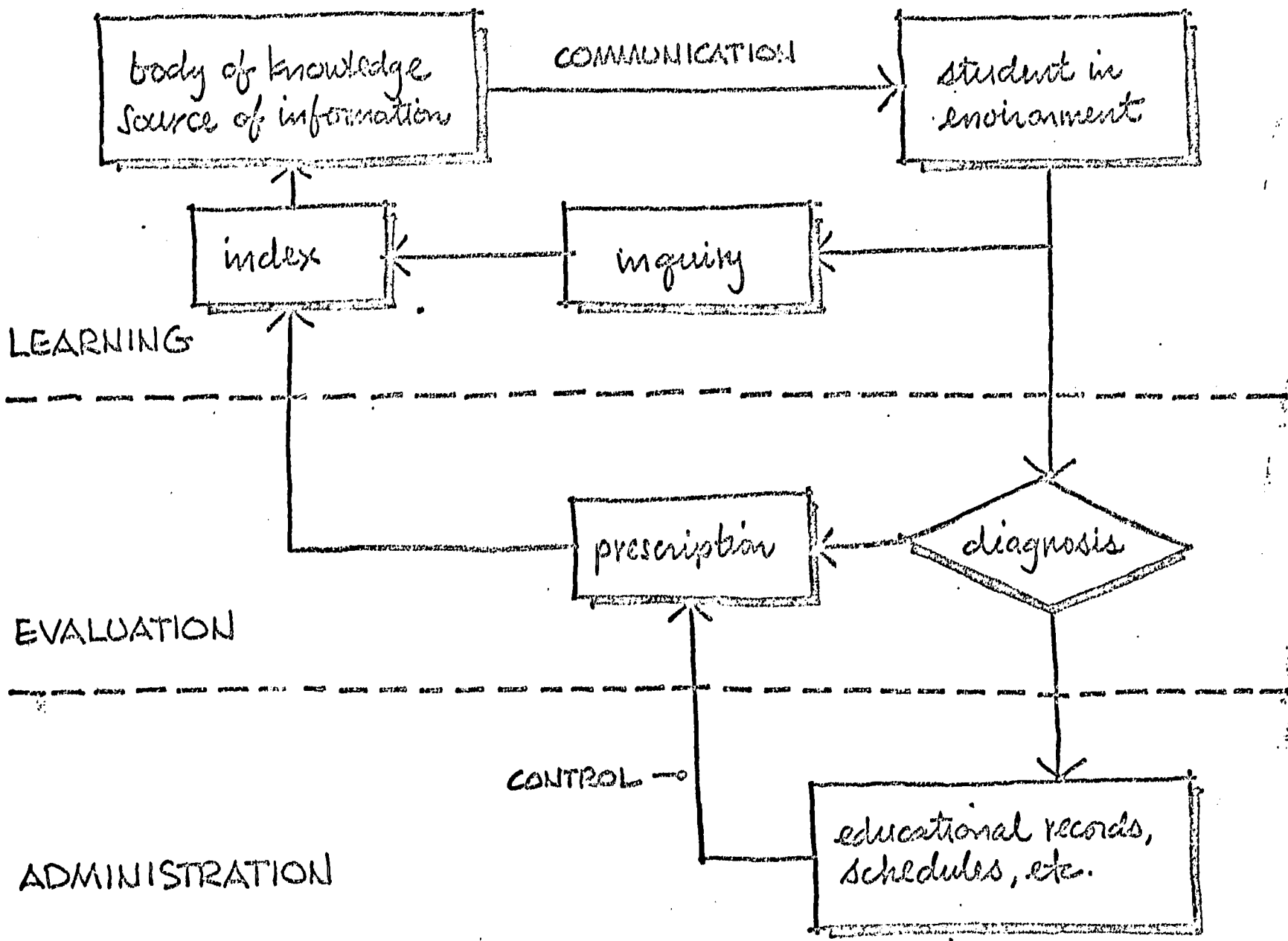

A MODEL SUGGESTED BY THE OAKLEAF SCHOOL
IN PITTSBURGH, PENNSYLVANIA
reported by Humphrey and Smith, Educational Technology, May 30, 1967

More and more electronic resources are being used to make the exposition process more effective, more economical, or to carry its message to more people. Examples include,

1. The use of "learning aids" in the presentation of materials (large graphics, projected materials, audio and video recordings, etc.).
2. The use of audio signals (telephone) to make exposition and communication direct and instantaneous.
3. The use of broadcast media (radio and television) to carry the message to large numbers of persons.

The expositions, then, may use electronic resources as AIDS in enhancing the communication, or it may make them an integral part of the process.

Electronic resources that may be used for exposition functions may include,

audio recorders, to play back recorded information
phonographs, for the same purpose
transparency projectors
slide projectors
motion picture projectors
microscopic slide projectors
internal television to magnify materials

television, to present information originating in a wide
 variety of locations
 video tape recorders, to play back video information
 telephones, to hear pre-programmed messages and to
 carry lectures from place to place
 dial access devices, to quickly access and play back
 ready-stored audio and video information
 computers, to access pre-programmed expository material

search and retrieval of information

Information storage, search and retrieval is a fundamental function on the
 college campus. Not only must the student undertake research and re-
 trieval (formal and informal) as part of the teaching-learning situation; the
 teacher, too, must engage in parallel processes in the development of
 learning situations and materials. Administrators must constantly find filed
 data to perform their daily tasks, and the information retrieval process is,
 of course, basic to the research sector on campus.

The information stored on campus may be extremely all-inclusive, far broader
 in scope than the kinds of data stored in the traditional library. It may in-
 clude,

reference and research items, as now collected in the library or
 elsewhere
 archival items, as now in the library and elsewhere

research papers and tracts, completed or in progress
instructional materials, including audio-visual items,
programmed sequences, etc.
computer programs and program documentation
contents of various administrative files
data pertaining to students, faculty, facilities and
other resources

Because it is approached in different ways, suggesting differing resources systems and differing facilities implications, it is handy to think of the campus information store as containing two fundamental classes of information:

1. INDEX INFORMATION, which is information about information, including tags and labels for the items fully included in the information store, and,
2. COLLECTION INFORMATION, which broadly refers to the full documents in the information store.

It is impossible to completely enforce the difference between these two "classes" of information; nor does the distinction imply that the user deals only in one class in any one sitting. Looking for a library-stored item, for instance, the user usually starts at the index level, seeking tags and descriptors rather than the full item itself; when he finds the appropriate tags, he

learns the location of the collection item, and finds the item (which, in turn, might suggest other index leads).

The charts on the next pages present the different approaches to storing, accessing and using both types of information. The differences are significant, since they dictate different electronic resources for access, retrieval and display.

As can be seen from the use patterns for each class of information, the high-speed computer is the "ideal" electronic resource system to access and retrieve index information. The large (but formal) data base, the existence of many descriptors and sort keys, the need to accommodate many different approaches for retrieval, the required access speeds, and the advantages of remote access all serve to reinforce this position.

As can be seen from the tabulation on page 12, there is no "ideal" electronic resource for accessing all parts of the collection. Based on the segment of the collection in question, the approach may include,

- manual retrieval and hardcopy facsimile
- microform (manual access and display)
- microform (automatic random access)
- manual checkout of audio items and equipment
- manual checkout of audio-video items and equipment
- distribution of audio materials, based on manual or automatic request
- distribution of video materials, based on manual or automatic request
- digital computer, possibly augmented by audio and video devices

COMPARISON OF "INDEX" AND "COLLECTION" INFORMATION TYPES AND USES

	index information	collection information
DESCRIPTION	"information about information", tags or labels for collection items	refers broadly to the full documents or files in the information store
INFORMATION INCLUDED	title or other label, subjects included, author, references to other items, abstract, location, other information about the item	disciplinary resources, reference material, research data, instructional material, recreational material, class notes, working papers, quizzes, information about students, personnel, rooms
FORMS OF THE INFORMATION	usually written using letters, numbers, special characters	may be written, graphic, three-dimensional, audio
USES	locate information in the collection; request the information; order, acquire and process the collection item; record circulation and duplication of the item; announce arrival of the item; produce catalogs and bibliographies, derive patterns of use	to inspect the full collection item; possibly borrowing, duplicating, or modifying it
GENERAL APPROACH	hierarchical or random search of index tags, with each tag possibly suggesting other tags or avenues of approach	not usually retrieved until index search is undertaken; inspection may suggest further index search
FREQUENCY OF ACCESS	quite high; user may review several items in one sitting	much lower, since user will have screened out many items in the index search
SPEED OF ACCESS	very high, with many items retrieved at once	quite low, since items will be retrieved one at a time
DEGREE OF DETAIL NEEDED	abstracted, higher-order tags, descriptive data	partial or full text and pictorial information
TIME TO PERUSE INDIVIDUAL ITEM	quite short, usually seconds	much longer, sometime minutes or hours
DEGREE OF USER MANIPULATION	very high, need to arrange, make lists, etc.	not as significant

COMPARISON OF "INDEX" AND "COLLECTION" INFORMATION TYPES AND USES

index information

collection information

NEED TO DUPLICATE OUTPUT FOR USER

only the "final" items selected by the user need be recorded and saved; form of output not often important

user may want to duplicate collection material, possibly in facsimile form

NEED TO UPDATE INFORMATION IN THE FILE

fairly often, to add new items and change details on existing entries

very high in some forms of collection information (research, administrative files, student evaluations, etc.) and very low in other forms (archives, etc.)

ELECTRONIC RESOURCES AND DEVICES

the high-speed digital computer is the most logical device for the search and retrieval of many thousands of index items in the short time usually desired to do the task

the devices will vary with the various segments of the collection - see the list on the next page

time-sharing allows remote access of index information

STORAGE, ACCESS AND DISPLAY OF "COLLECTION" INFORMATION

segment of collection	storage	access	display
HIGH-ACCESS WRITTEN MATERIAL	coded on random access media	computer	graphic and printer
HIGH-ACCESS GRAPHIC MATERIAL	facsimile	random access facsimile	facsimile projection
GENERAL DOCUMENTS	original and facsimile	manual	facsimile projection, browse original
GENERAL DOCUMENTS ON RESERVE (HIGH USE)	original and mul- tiple facsimiles	manual	facsimile projection
ARCHIVAL MATERIAL	original	make facsimile	facsimile projection
RESEARCH PAPERS, ETC. IN PROGRESS	coded on computer media	computer	graphic and printer
FILMS, TAPES, AND SLIDES	originals and dup- licates	manual	projected, with audio if necessary
AUDIO RECORDINGS	originals and dup- licates	manual	recorder, telephone
READY ACCESS AUDIO MATERIALS	ready-mounted on tape decks	dial access	recorder, speaker
READY ACCESS AUDIO- VIDEO MATERIALS	ready-mounted on tape decks	dial access	television, recorder, speaker
CAI PROGRAMS	coded on random access media	computer	graphic, printer, pro- jected, recorder or speaker
COMPUTER PROGRAMS	coded on computer media	computer (random or manual)	graphic and printer
ADMINISTRATIVE RECORDS (ARCHIVAL)	facsimile	manual	facsimile projection
ADMINISTRATIVE RECORDS (CURRENT, HIGH-USE)	coded on random access media	computer	graphic and printer
RECREATIONAL MATERIAL	originals	originals	originals

manipulation of information

Not all retrieved information is simply perused and returned to its place of storage. The user may want to alter it, add to it, purge it from the system, complete it (as in the case of using programmed instruction), or to compare it to his own performance (as in the case of recording his own voice in a language or speech lesson).

The teacher may want to retrieve and alter learning sequences, evaluate programmed learning units, or rearrange student data. The administrator is constantly updating information, as are research personnel. The student may take a language lesson, interact with a computer-assisted instruction unit, or attempt to write and debug a computer program.

The role of electronic resources in providing this manipulative capability is becoming more significant all the time. Approaches and resources may include,

- manual check-out of multiple-track, record-and-playback audio devices and tapes
- manual use and play back of video tape recording equipment
- dial access retrieval of audio and audio-visual, recording-and-playback programs
- computer access and manipulation of CAI programs
- computer search, retrieval, display, manipulation and restorage of information files, partially-written computer programs, research data, working papers

computer presentation of games and simulations
use of miniaturized learning aids

evaluation of performance

The need to ascertain, evaluate and create diagnostics for performance is an important university function. Students and student progress must be evaluated against appropriate norms; teacher performance must be measured; learning materials and resources must be evaluated; administrative policies must be tested and reframed if necessary; and the researcher is always in the evaluation business.

Any emphasis on individualization of curricula absolutely necessitates improved attempts at evaluation, not evaluation by the week or month, but evaluation by the minute or hour. The increased use of new teaching techniques and learning materials, too, demands a more rigorous approach to evaluation or valuable time will be wasted in ferreting out ineffective components of teaching-learning.

The need for quick and detailed evaluation has led to the use of electronic resources for,

measurement of student response during large-group lectures
transmittal of student response to computers for processing, individual student evaluation, and evaluation of instructor performance.

computer capturing and processing of student responses during
 programmed learning sequences
 computer-based grading of tests and essays
 computer-assisted counseling of students

teaching-learning support

Teachers, administrators, educational researchers and students are constantly striving to improve the quality of teaching and learning on the college campus. Sometimes this is done by the evaluation of existing techniques and materials, and sometimes it is done by the development of new techniques and materials.

The use of electronic resources in the development of teaching techniques and production of learning resources may include,

- inexpensive production of learning materials by teachers, students, and administrators
- sophisticated production of learning resources by faculty and support staff
- origination of televised materials
- preparation of programmed instruction sequences
- preparation of computer-assisted instruction sequences
- simulation of student performance using new teaching techniques or resources

general administration

The need to effectively and efficiently allocate and account for the univer-

city's resources - people, materials, money, time, facilities - is the unending task of administration. The use of various electronic-based resources to fulfill this task is not new to administration, and often includes,

- production of visual aids and materials to portray administrative situations
- business data processing and accounting
- development of central data banks concerning university resources
- computer-assisted scheduling and allocation of resources
- student tracking by computer
- facilities utilization and planning techniques

"systems"

From the preceding pages it can be seen that many electronically-based resources are available to assist in the many functions of the university.

Some of the resources appeared many times in the discussion (and are therefore suitable for use in many of the university's tasks) while others seem more limited to special purposes. Some are of great simplicity, while others represent great sophistication and expense. Some are clearly within the current state-of-the-art, others in various stages of development. All have implications for planning and programming college facilities.

In order to develop these facility implications, and then to apply them to university planning in general, it is necessary to organize the items in the various lists into usable form. While the job is not an easy one, it is obvious that many of the resources "belong" together; they use common materials, require a common complement of equipment, are administered on a common basis, or demand a common set of facilities. Using terms in current favor, they form "systems", or as Webster defines them, "assemblages of objects united by some form of regular interaction or interdependence."

the computer resource system

The most striking example of a resource system is that which revolves around the digital computer. Computers may be used on campus for teaching, research, library search, computation, evaluation, payroll processing and dozens of other functions. Some of these are "instructional", others of a "research" nature, and still others in the arena of "administration." For each group of users to decide on the need for computer assistance, and then to purchase, install and operate its own computer system is sheer folly. In order to assure effective and efficient operation, it is necessary to look at all of the potential uses and roles for the computer in the university environment, and then to design and implement one or more fully integrated and compatible computer systems to carry out the tasks. In this kind of thinking the "computer resource system" is born. This will be discussed in some detail in Part 2.

the audio-video resource systems

Two more common groups or systems begin to show themselves when audio and audio-video resources are examined. These, too, are used by a variety of people in a variety of situations for a variety of purposes. The organizing factor, however, is the notion that the materials (be they slides, models,

films, audio tapes, kinescopes or whatever) are common to all situations. These materials may be handled directly by the user, or they may be distributed to him over the air or through cabling networks. Part 3 presents facility implications for non-distributed audio-video resources, and Part 4 takes up the implications for distributed audio-video resources.

the facsimile resource system

A special type of visual resource on campus is the facsimile reproduction of written or graphic material. The problems of storing, accessing, retrieving and using information in its original form are becoming more and more critical and are dictating a whole new set of equipment and facility implications. These will be presented in Part 5.

the limitations

These four categories may not be the best or most comprehensive in covering the various electronic-based resources used in the university environment. They do, however, seem to form a workable basis for assembling facilities implications.

the approach taken

The approach taken in the remainder of this report is to present each of the four primary resource systems, to make some introductory comments, to develop facility implications for the parts of the system that the user most often sees (the request/presentation aspects) and then to develop facility implications for the storage, distribution, and support elements that are often out of the user's direct view. In every case, introductory and summary comments are made, with planning and programming data collected and presented on Facility Data Sheets - each designed to present one facility component required to implement the resource system under discussion.

2

COMPUTER
RESOURCE SYSTEM

In terms of its potential, the most far-ranging electronic resource system on the college campus is the high-speed digital computer and its network of remote access points. As has been suggested in the first Part of this report, it may be used for,

1. Computation for all members of the academic community.
2. Training in the computer sciences.
3. Access to pre-programmed expository materials.
4. Access and manipulation of computer-assisted instruction packages.
5. Presentation of educational games and simulations.
6. Search, retrieval and display of index information.
7. Search, retrieval and display of some parts of the university's information store (collection).
8. Search, retrieval, manipulation and restorage of information files, partially-written computer programs, research data, working papers, etc.
9. Evaluation of student performance, both in large groups and individually.
10. Evaluation of learning materials and techniques.
11. Counseling of students.

12. Preparation, monitoring and evaluation of computer-assisted instruction packages.
13. Simulation of student performance using new techniques or resources.
14. Individual tracking of students.
15. Business data processing and accounting.
16. Development and manipulation of central data banks containing information on university resources.
17. Allocation and scheduling use of all university resources.

the computer system

By its very nature, the computer resources on campus form a tightly-woven system. Hundreds of remote access points may be interconnected with one or more central processing units. If there is more than one processor, the processors in turn may be linked to each other, and to many others throughout the State University, the state, the country, or the world.

This, of course, presumes the existence of large "time-shared" computing systems where many terminals (perhaps 200-300) can share remote access to a large central processor. While software problems are restricting development of systems of such magnitude today, it is probably safe to plan on their effec-

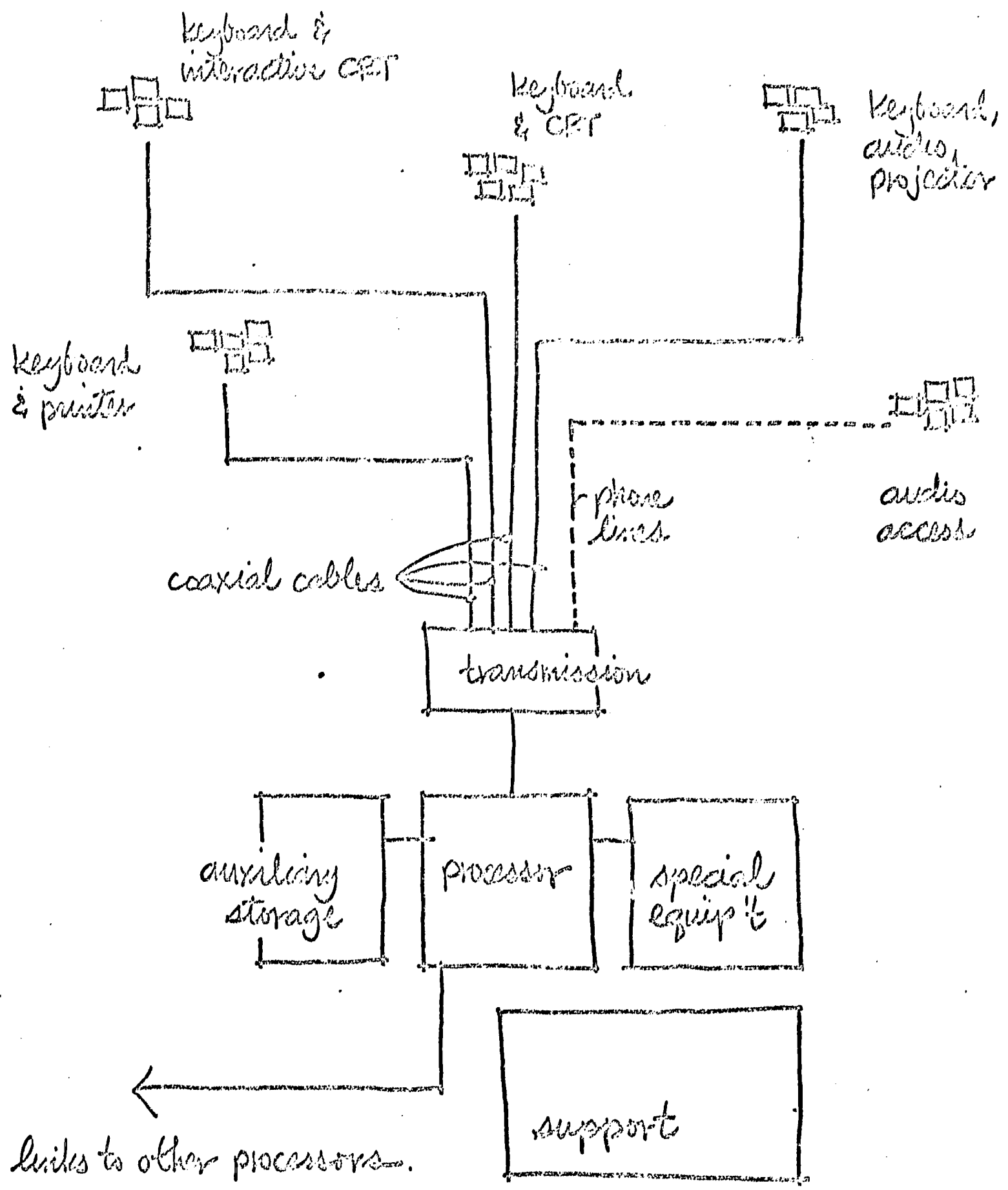

* TIME-SHARED COMPUTER SYSTEM

tive operation by the 1970's.

the system's components

The time-shared computer system includes three major building blocks or components:

- The REQUEST/PRESENTATION NODES, the devices that allow the remote user to access the computer system and to see its results.
- the CENTRAL EQUIPMENT COMPLEX, which provides the computing capability, the storage of information, and the various devices for operating, maintaining and improving the system.
- the CENTRAL SUPPORT FUNCTION, which provides administration, staffing, programming and other support activities.

All of these components are tied together by some sort of distribution network.

the approach

The next section of Part Two presents the parts of the computer system which are "visible" to the user: the request/presentation nodes and their facilities implications.

Because central equipment and central support are usually housed together in some form of "computer center", the storage and support activities with their facilities implications form the final section of Part Two.

request/presentation devices

The time-shared computer system is like an iceberg; the user only "sees" a small part of it in action - the device used to remotely access the central computer.

While many types and models of remote request/presentation devices have been produced, they seem to fall into some generic categories in terms of facilities implications:

- keyboard and printer
- keyboard and CRT (cathode ray tube)
- keyboard and interactive graphic display
- keyboard, audio and projected visual display
- telephone (audio access)

These request/presentation approaches and their facilities implications are presented on Facility Data Sheets A-1 to A-5.

computer terminal locations

Since the primary advantage of computer-based request and presentation methods is one of quick and convenient random access, it would suggest that various request/presentation devices would be scattered around the campus, located in close proximity to expected users.

the individual terminal

Some remote request/presentation devices will be singly located in special places throughout the campus and planned for high utilization, single-user use. Keyboard-and-printer and keyboard-and-CRT terminals may be singly located in some research laboratories, some faculty offices, some business offices, programmers' areas, and in some special offices (such as that of the Registrar). Special keyboard and interactive graphic display units may be located in their own research laboratories (see Sheet A-3).

Where the individual terminal is placed in areas designed for other uses (offices, laboratories, etc.), the appropriate Facility Data Sheets (A-1 to A-5) should be consulted for possible environmental conflicts.

devices clustered in "terminal areas"

Most of the university's request/presentation devices will probably be designed for high utilization and located in public or semi-public areas, available to all students, faculty and staff in the vicinity. The cost of terminal devices suggests that their "hoarding" in student and faculty areas (with corresponding poor utilization) may be hard to justify economically.

There are also advantages to be gained from clustering or grouping from two to six or eight request/presentation devices in "terminal areas" scat-

tered throughout the campus:

1. Clustering a number of different terminal types gives the user greater flexibility in selecting which device most closely fits his need. This should increase overall terminal utilization in the area.
2. Some terminal types (such as the CAI device described on Sheet A-4) require supervision or nearby attendance. This can be more economically provided if these terminals are clustered.
3. Any auxiliary devices deemed appropriate (such as hardcopy devices, electronic calculator to check computations, etc.) can be provided in the terminal areas and serve a number of users easily.
4. Air conditioning, while not required, can be provided.
5. Terminal maintenance is easier to provide.
6. Coaxial cable access points are minimized; judicious locations of areas can reduce cable runs.

These terminal areas may be located within academic areas on the campus, in research and work areas, within the residential complexes, adjacent to information storage and browsing areas, in faculty and staff office areas, and

in other well-utilized areas such as the student union. Their number and location must be predicated on the number of terminals the individual university or college expects to have available and its specific approach to allocating them.

Sheet A-6 presents programming data for terminal areas in general; the following pages present some "typical" terminal area configurations.

special request/presentation nodes

As more computer applications are constantly developed, special request/presentation terminals come into use. On-line monitoring of scientific experiments, on-line recording and processing of student responses gathered during lectures, and other special remote terminal types may be used on college campuses in several years.

Since it is impossible to forecast the types of unique terminals any campus may require, and because the state-of-the-art will favor earliest development of "common-use" terminals first, special request/presentation nodes have not been considered in the following Facility Data Sheets.

description: This is the simplest and most common way of accessing a computer or a computer-based data store. The input method is tactile, using the fingers to depress keys on a typewriter keyboard, with some extra "command" and format keys added. The output is typed on a paper roll.

uses: Some CAI packages; retrieval of bibliographic information; computer programming and debugging; computation; administrative tasks. This input/output unit can handle most of the common, everyday computer access.

locations: Resource center; academic areas; residential areas; faculty and administrative office areas; research and laboratory areas. Some may be in personal offices, but it is suggested that "terminal areas", public or semipublic, be distributed among the locations above (see A-6). Each may include from one to three or four terminals (perhaps of different types) for use of all persons in the area (all faculty in a department, etc.). Locations should be accessible for 24 hours a day.

space required: 60 square feet/terminal station; if some adjacent area for user study of printed output can be provided, the individual on-line utilization of terminals will be increased.

lighting: Standard levels; avoid glare on keyboard.

acoustics: Several of these terminals in a single area will produce acoustical problems because of the noise from the typing mechanisms. No more than two to three terminals should be placed together without an acoustical barrier between them. Walls of terminal area should include absorbing surfaces to reduce internal noise levels and transmission through walls.

mechanical: Air conditioning; no direct venting of terminal needed.

electrical: Standard voltages (see DISTRIBUTION).

general: Handy disposal for unkept output paper.

description: This device replaces the printer mechanism with a Cathode Ray Tube (CRT) which displays line and character information. Through some keyboard controls, the user may have the capability of retaining, erasing, or shifting information on the display. He cannot, however, directly input any graphic information without some interactive device (cf., light pen).

uses: Many of the same uses as the keyboard-and-printer combination, with greater emphasis on uses where hardcopy is not needed (i.e., CAI, bibliographic retrieval where the user does not anticipate long lists; straight computation; program debugging; administrative tasks where hardcopy is not needed).

Costs are coming down; material is displayed more quickly than the printer, and since these units generally take up less space than the printer, they will probably tend to replace printers for tasks where hard copy is not needed.

locations: Same locations as keyboard-and-printers. Perhaps one of each (or combinations) might be located in "terminal areas" spread among student, faculty, administrative and research areas. This gives the user some flexibility in choosing the right terminal for the right job. Locations should be available to users 24 hours a day.

space required: CRT-and-printer terminals are sold which can sit on a standard tabletop. 20-25 square feet/station, with counter to set the unit on, and to provide a writing surface for the user. Some models can be placed on typewriter stands.

lighting: Standard levels, avoid direct light or glare on CRT surface.

acoustics: No significant problems.

mechanical: Air conditioning; no direct venting of terminal needed.

electrical: Standard voltages (see DISTRIBUTION).

general: Some visual privacy should be afforded the user, in order that he is not distracted by other graphic displays in the vicinity. This can be accomplished by using divider panels between stations (full enclosure of each station is not necessary).

description: This device combines a user-controlled "light pen" or other interactive source with a writing surface (CRT, or horizontal metal tablet) and keyboard. By pointing the light pen device to the screen, and by depressing appropriate control keys, the user can "draw" on the display, "erase" information from it, shift it around, and otherwise modify it. As changes are made on the screen, they are, of course, charted in the computer's memory.

In order to avoid large computing power "drains" on the central processor, it is usually necessary to provide a small satellite computer or at least a data buffer in the immediate vicinity of the interactive display.

uses: Used only for work in which user-initiated graphics is of prime importance, e.g., some forms of research, architecture and civil engineering projects, etc.

locations: Because of the expense of such terminals, there will probably be very few on campus. Location should be in a lockable, attended (or closely attended) area such as a laboratory. Cable limitations may limit distance from central processing unit; manufacturer specifications must be checked.

space required: A "room" of 100-120 square feet should probably be considered for such terminals and their accompanying satellite computers or data buffers.

lighting: Standard levels; avoid glare or reflections on display tube.

acoustics: No significant problem.

mechanical: Air conditioning; the display unit itself will probably not need direct venting, but the architect should be careful to see what "support" machinery (small computer; buffer unit) may require.

electrical: Special power service will likely be required (see DISTRIBUTION).

A-3 (continued)

general: It is hard to generalize on requirements for sophisticated graphic input/output units. In general, however, they are more like computer processors in their requirements for special service, humidity controls, air venting, etc. than straight input/output devices. Manufacturer specifications for both LOCATION and ENVIRONMENT must be consulted before final design decisions are made.

description: This is a special input/output unit developed for CAI uses. Material is presented to the user by printer, projected slides, and audio tape; the user interacts with the computer via keyboard. The slide and audio components include a remotely-controlled 2x2 slide projector and a remotely-signalled audio tape recorder; both are located in the user's station.

uses: Computer-assisted instructional packages.

locations: A few in student residential areas; a few in academic areas where students may have blocks of 20-30 minutes of time to spend with these specially-augmented CAI packages. Concentrations (clustering) recommended since an attendant will have to be in the vicinity of the terminal to solve problems, maintain projector and recorder, assist users in familiarization.

space required: About 60 square feet/terminal; 60-80 square feet office and attendant's area for each cluster of 3-4 terminals. (Office with glass vision panel to terminal area). Office can be converted into additional terminal area should its presence be unnecessary; therefore it should incorporate all the environmental criteria of the terminal areas. Locations should be available 24 hours a day (assuming the problems of the attendant can be solved).

lighting: Standard levels, avoid glare on keyboard and reflections in CRT tube. Do not train point sources on CRT or rear projection screen.

acoustics: Although there are printers on many of the CAI units, the student's headphone tends to block the sounds from his ears. Walls of terminal areas should include absorbent materials, however, to reduce internal noise and transmission to adjacent spaces.

mechanical: Air conditioning; no direct venting of terminal necessary.

electrical: Standard voltages (see DISTRIBUTION).

general: Visual privacy should be afforded (to avoid distractions); but complete enclosure of unit is not necessary.

description: A conventional touch-tone telephone handset can be used to access (by depressing the buttons) and receive (aurally) computer-stored information.

uses: "Quick-and-dirty" requests for bibliographic information, locations of campus events, etc. are most efficiently handled by such devices.

locations: Every touch-tone telephone handset is a potential computer terminal once a system is established.

space required: No additional space beyond that required for a standard telephone.

description: A number of various computer request/presentation devices may be clustered together to increase utilization and promote operating efficiencies. Devices may include a "mix" of keyboard-and-printer, keyboard-and-CRT, and CAI units.

size and configuration: While exact size ideally depends on the exact configuration of devices used, the uncertainty of just which terminals will be provided suggests the programming of fixed area spaces which can be subdivided in a number of different ways. The next pages present a number of schemes based on areas of 168 square feet (14' x 12'), and 288 square feet (14' x 24').

locations: Terminal areas may be located among classroom, faculty, staff and research areas, in student residence areas, and in other special places on campus (such as the student union). All locations that do not require supervision should be available to students as many hours in the day as the computer is available to serve them (potentially 24 hours a day; 7 days a week).

access: From main or secondary circulation areas.

structural considerations: Raised flooring not necessary, inappropriate column bay spacings will limit potential configurations (see following pages).

lighting: Standard levels; point light sources should be avoided since there is the possibility that CRT screens will be used in the room.

acoustics: Since some keyboard-and-printer devices may be used, ceiling should be acoustically treated; semi-enclosing acoustical dividers can handle the remaining noise produced by the units. If located directly adjacent to main circulation, usual classroom standards should be applied to reduce intruding noise. Doors with glass vision panels should be provided to all circulation areas.

mechanical: Air conditioning is not absolutely required, but is suggested. It not only helps to compensate for the relatively small amounts of heat given off, but should improve user utilization of the terminals.

A-6 (continued)

electrical: Standard voltages (see DISTRIBUTION).

furnishings and equipment: Keyboard-and-printer and CAI-type are self-contained and free-standing; keyboard-and-CRT units may require table top space. Worktable for calculator and copying devices may be included. Seating should be comfortable and preferably vertically adjustable to accommodate users of varying height.

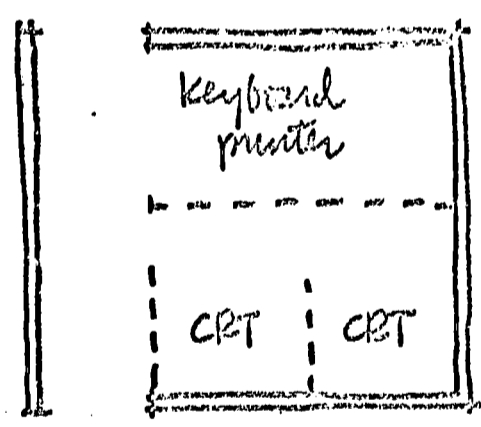
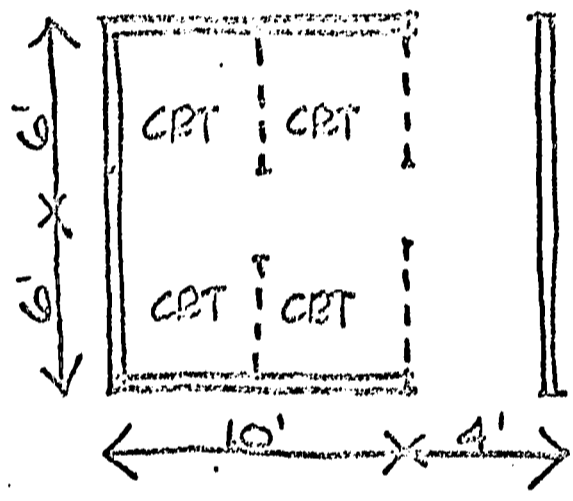
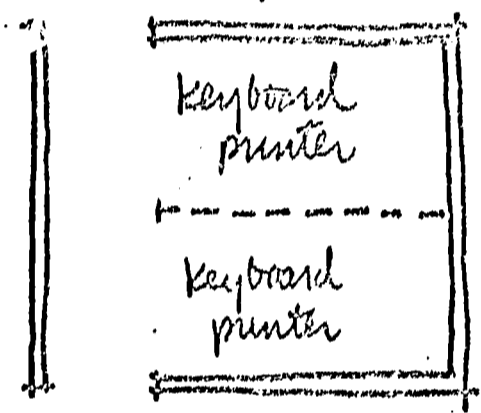

MODULAR TERMINAL

AREAS - 163 SQ. FT. GROSS

A-6 (continued)

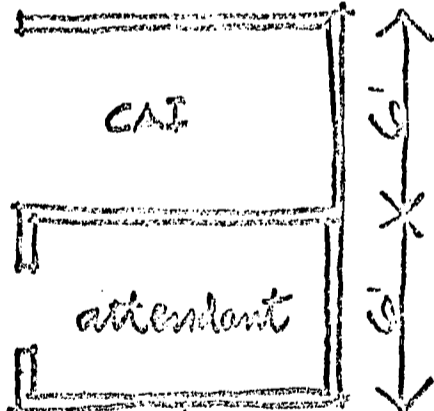
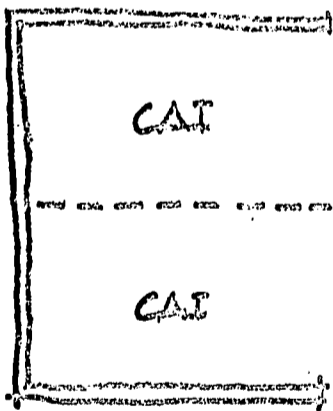
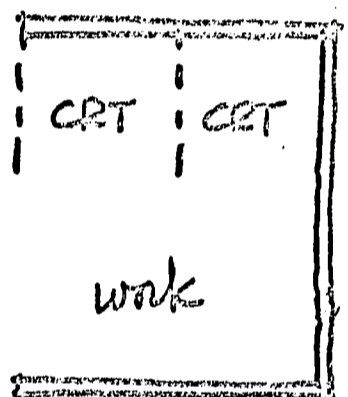
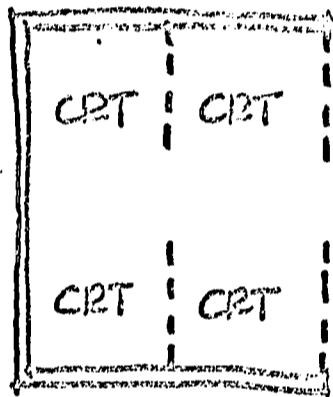
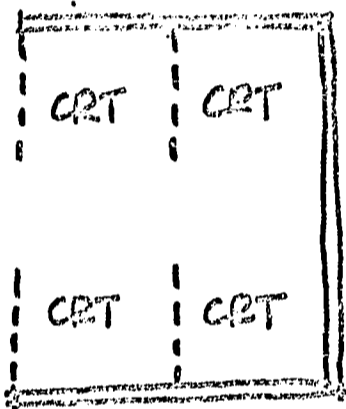
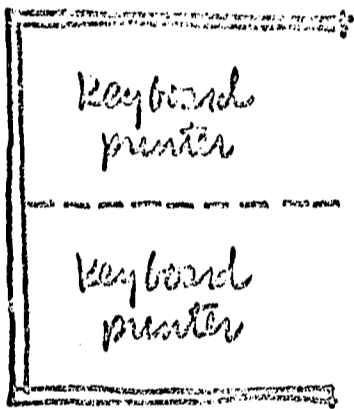
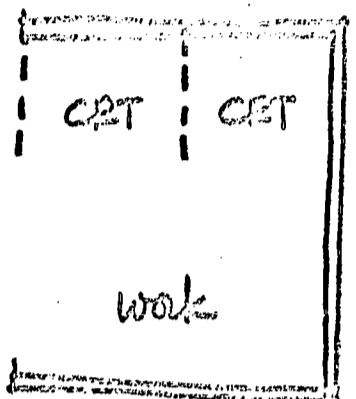
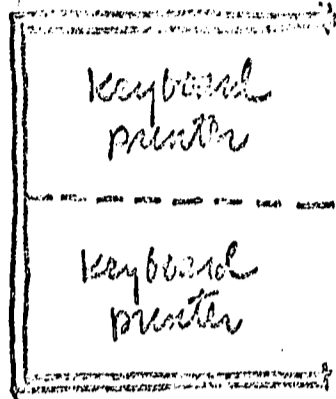
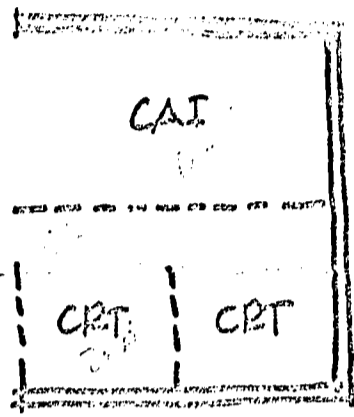
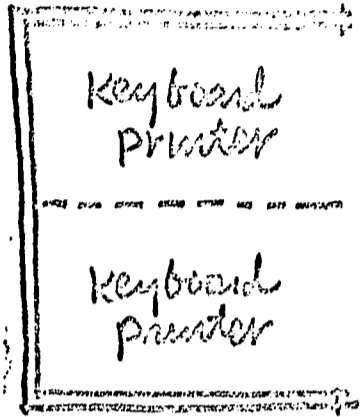
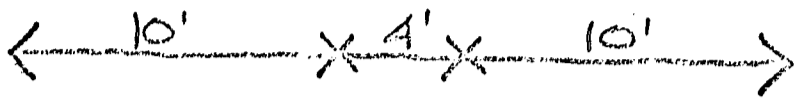

MODULAR TERMINAL
AREAS - 288 SQ. FT.

the computer "center"

The storage and support components of the computer resource system are necessarily centralized in a computer "center". This center contains the processing equipment, storage devices, special machinery, administration, and supporting staff. It is tied to the various request/presentation nodes by coaxial cable or telephone circuitry and, indeed, it may be thus tied to other processing centers.

the university's approach

Before making any comments about central computer facilities, it is important to realize that approaches to computing and the use of the computer vary greatly from university campus to campus.

All college or university centers will use computers for administrative and business tasks. Beyond this, however, each will add its own emphasis. Areas of concern may include:

1. EDUCATION IN THE COMPUTER SCIENCES, varying from the small, support-only program undertaken at an installation specializing in liberal arts to the highly complex universities who are training future computer specialists. The kind of on-campus educa-

tional program will have much to say about computer center orientation and use.

2. SUPPORT OF THE EDUCATIONAL PROGRAM, by degree of computer-based information retrieval and computer-assisted instruction.
3. COMPUTER-SUPPORTED RESEARCH ACTIVITIES, varying from a few interested faculty members to a complex research operation.
4. RESEARCH IN THE COMPUTER SCIENCES, suggesting that some computer centers are content to be dependent on others for advances in hardware and software, while others must advance the state-of-the-art themselves.

These factors have implications for equipment, staff, space, and the organization and operation of the computer center.

if each of the above areas of emphasis is heavily pursued on the campus, the inevitable question of "dedicated" computer systems comes up. While the third generation machines are more capable of handling a wider variety of tasks than their predecessors, problems of extra-high utilization may still re-

quire more than one computer "system" on campus.

When retrieval of index-type information becomes an everyday function, it seems likely that one processor (and its array of auxiliary storage devices) may have to be dedicated to this cause. If this appears to be desirable in terms of the situation on the individual campus, it is suggested that,

1. The linking of all central processors on campus be carefully considered. The information retrieval computer, for example, may be well suited to accept longer computing jobs as "background" during daytime hours, and as its main tasks during hours when user requests may begin to lag (early morning, late evenings, etc.). The processor-to-processor link does not necessarily require the close physical proximity of the processors.
2. The sharing of some of the most expensive peripheral devices be carefully considered; this would suggest a close physical relationship of the two systems.
3. The sharing of administrative and some supporting staff should be most carefully considered; this, too, suggest a close physical relationship of the systems.

The following paragraphs will briefly explore the implications of varying approaches to computing on equipment, staff and space.

equipment needs

The particular approach taken by the individual college, the role of the computer in all of its activities, the projected usage of the equipment, the extent of its financial resources, and the possibility of regional hook-ups with larger computers will all have to be taken into consideration in the choice of equipment.

Computer systems have been marketed to fulfill nearly every need, from the small and unilateral application to complex applications.

The most recent "third generation" of computing equipment (the various models of the IBM System/360 line and their competitive cousins) combine great amounts of computing power with wider flexibility of use and time-sharing capability. The assumption is that colleges and universities of any size will be most interested in this generation of equipment, but even within the model series there are many choices to be made. (IBM's System/360 seems to open-ended, offering Models 20, 30, 40, 44, 50, 65, 67, 75, and

even larger configurations; each is larger, more powerful, or dedicated to some more special purpose than the preceding models).

The National Academy of Sciences-National Research Council, in its study of "Digital Computer Needs in Universities and Colleges" established (for purposes of discussion) four general classes of computers:

- TYPE A, incorporating a minimum of 350,000 additions in one second, minimum memory of 65K words, and a minimum word length of 36 bits. This includes the very large IBM 7094 (Model II), CDC 6600, CDC 3600 as illustrative systems.
- TYPE B, incorporating a minimum of 100,000 additions in one second, minimum memory of 30K words, and a minimum word length of 24 bits. Examples include the CDC 3200, IBM 7094 (Model I), Univac 1107, IBM 7090, CDC 1604, IBM 7044, RCA 601, Burroughs B5000, Honeywell 1800, and IBM 7074.
- TYPE C, incorporating a minimum of 10,000 additions in one second, minimum memory of 10K words, and a minimum word length of 20 bits. Some examples include the IBM 7040, Honeywell 800, GE 225, and the IBM 7070.

- TYPE D, not in any of the categories above, are slower, with smaller memory, or limited in some other way. Examples include the PDP 4, CDC 160, SDS 910 and 920, NCR 304, GE 210, IBM 1410, RCA 301, Honeywell 400, IBM 1620, IBM 1401, and many others.

A full listing of machines and classifications as of January 1964 is included in the document cited above. The exact boundaries of the classifications are unimportant in terms of the discussion underway; they will serve, however, to give scale to some of the data and conclusions reached by the NAS-NRC study.

staff

Staff is, of course, a function of the individual computer center's size, emphases and scope of operations. Based on the data amassed as part of its university computer needs study, the NAS-NRC group cited above produced the estimate of typical university computer staffing (1961) presented on the next page.

It is important to recognize, however, that times change and that averages

<u>System Type</u>	<u>Supervisors & Analysts</u>	<u>Programmers & Coders</u>	<u>Operators</u>	<u>Total</u>
A	10	20	10	40
B	6	15	7	28
C	3	9	3	15
D	2	3	1	6

from "Digital Computer Needs in Universities and Colleges", a study by the National Academy of Sciences-National Research Council, published in 1966.

are necessarily misleading. State university sources and installations should be analyzed before specifics are determined for any one campus.

If the computer center moves into sophisticated information retrieval techniques, and as it attempts to serve the wide variety of users on the university campus, the number of programmers should not be minimized in any way. In addition to the above staff, the computer sciences faculty (if any) must be considered in the planning of space.

space

Space needs will vary according to the size of the system installed, the number of staff to be considered, and the possibility of changing to a larger computer system.

Facility Data Sheets A-7 to A-17 present the various spaces required in the computer center - first equipment and then user areas. Projected square footages, leaning heavily on the results of the NAS-NRC study, are given on the Summary Sheets A-7 and A-13. All of these sheets assume the existence of one central computer system; if combinations of "dedicated" systems and supporting staffs are to be used, these square footages will have to be modified accordingly.

costs of computer facilities

It would be presumptuous here to make any predictions or even guesses on the cost of computer space. The same NAS-NRC study referred to above, however, makes an interesting statement on space costs: "the capital cost of construction of space to house a facility is about equal to one year's annual cost (operating plus rental)".* This relationship was derived from their study which actually took place in the 1961-1963 time period (with some updating in 1965); the State University is undoubtedly in a better position to find out more specific costs for computer facilities.

*This estimate was based on the assumption that the cost of constructing computer centers ranges about \$40 a square foot.

location of computer facilities

Central location and access from the user's standpoint is not as important in this type of facility as it is in the traditional computational center. Students and other users do not have to "stop in" daily to pick up output, submit programs, make statistical or computational checks, discuss problems with their instructors, and so on. As has been suggested, the average user rarely "sees" the computational center in operation. When users do come, they will come to put in concentrated efforts in running and debugging programs, to work on input for the system, etc.; this suggests that they will come and stay awhile rather than constantly dash in and out.

Service, maintenance and materials access is always important, though, which suggests location near a service artery.

For these reasons, a central campus location may not be necessary. It is suggested that the location of the center not be so remote that it actually discourages "clients" and visitors, but the need to place this particular function at the circulation hub of the campus is not as clear as the student-oriented center.

relation to a state-wide system

If this information store does not exist alone, but is part of a state-wide system with several processors and shared information stores, it is obvious that the complexion of any one of the components would change.

The make-up of such a system will, of course, determine the details for the various components. Assuming for a moment that such a system might consist of two different kinds of centers, it is possible to say,

- o REGIONAL CENTERS would contain the large processors, large bulk storage (data cells, etc.) and the bulk of the analysis and programming support components. These would require substantial square footage increase over those given here.
- o SATELLITE CENTERS would contain smaller processors (linked to the large regional computers), less bulk storage and possibly fewer professional staff. Equipment areas may be reduced by 25%-50%; media storage, dispatching and ready areas should remain as noted above.

CENTRAL EQUIPMENT AREAS
A SUMMARY

A7

description: The housing of the central processor and its on-line equipment (A-8), associated off-line equipment (A-9), media handling (A-10), equipment maintenance (A-11), and distribution (A-12) areas. Details for each are given on the appropriate Facility Data Sheets.

size: Size depends on the size of the system to be housed and the possibility that a larger set of equipment may be housed in the future. The following chart is drawn from the NAS-NRC study; suggested modifications in terms of planning time-shared systems (not included in the study) are included as notes to the chart.

<u>Use</u>	<u>Type A</u>	<u>Type B</u>	<u>Type C</u>	<u>Notes</u>
Computer room	2,500	2,500	1,500	
Dispatching room	1,000	600	400	Dispatching is less critical where most users are remote; suggest that areas be cut in half and incorporated in computer area.
	(500)	(300)	(200)	
Auxiliary, keypunch, duplicating, storage	2,500	2,000	1,000	
Maintenance area	400	400	200	
TOTAL SPACE REQUIRED	6,400 (5,900)	5,500 (5,200)	3,100 (2,900)	"Adjusted figures".

configurations: It is suggested that the total equipment area be thought of as a single entity in planning and design - a large "room" that can be subdivided as necessary by some type of demountable partition. This allows maximum flexibility both in sizing and in layout. For this reason, the area should not be of particularly odd or torturous configuration. A square or rectangular area would yield the most flexibility.

description: Accommodation of a unit for sending and receiving facsimile information over telephone circuits. These are often table-top devices, usually associated with a telephone handset.

size: A typical hardcopy sending/receiving unit (which sends a page of copy in 6 minutes) measures 20" x 16" x 12"h and sits on a table top. Other, more expensive devices requiring special "Telpak" telephone circuitry are larger, but no larger than a standard office desk or work table.

locations: The university may use such a device for campus-to-campus communication or other special-purpose uses. (The relative inefficiency of these devices will preclude use for standard transfer of facsimile information).

all other aspects: No additional requirements for the small, table-top units.

MICROFORM PRESENTATION AREA

103

description: An area including one or more microform readers and associated hardcopy production equipment. The presumption is that the user will make an index search at a computer terminal (A-6), retrieve manually the microform item (D-5), and take it to a presentation area. The presentation area he chooses may or may not be in the vicinity of the storage and check-out areas.

size and configuration: An individual microform reader generally sits on a table top, is 15"-20" wide, 20"-30" deep and 20"-30" high. The individual user, then, requires a station which is 4'-6" wide and 4'-6" deep (approximately 20 square feet) or 5'-0" deep (22.5 square feet) if it is enclosed at the user's rear. The addition of circulation space suggests a per user standard of 30-35 square feet.

Hardcopy stations are approximately the same size. One approach (like that of the terminal room, A-6) would be the location of several microform presentation units and a hardcopy production unit in a "room" or semi-partitioned space. Unlike the computer terminal area, acoustics does not place a significant limit on the number of student stations in the same area.

location: Some presentation areas should be located within the microform centers (directly accessible from check-out and storage areas), while others should be located independent of the storage areas (assuming that users will check-out materials and study them at their convenience). This suggests location of "isolated" readers in research areas, academic areas (perhaps 1 or 2 per department at the outset), and in student residence areas (perhaps in the vicinity of the "semi-public" computer terminal areas).

lighting: Darkening is not required, but point lighting sources that might cause screen glare should be avoided. Many manufacturers provide overhead light shields on the readers themselves to improve image quality.

acoustics: No significant problems. If presentation areas are not fully enclosed, carpeting in the circulation, check-out and terminal areas will reduce the level of noise in the area. Placement of presentation areas along major circulation routes requires full enclosure (door).

mechanical: Standard requirements; air conditioning would improve comfort (and probably utilization) of all microform areas.

D-3 (continued)

electrical: 110v convenience outlet for the readers.

furnishings and equipment: Work table for reader and user, temporary storage for books and notes, coat hook.

the components

The microform storage and support area includes all the facilities necessary for microform collections, request and check-out, and duplication of microform resources. These include,

- o User search and retrieval area (computer terminal areas as described in Facility Data Sheets A-1, A-2, A-5 and A-6).
- o Circulation control and check-out area (D-4).
- o Microform storage area (D-5).
- o Microform production and duplication area (D-6).

locations on campus

The great reduction in bulk that accompanies the use of microforms allows the university to "rethink" the library question. Instead of one large, central resource collection, the campus may include a number of microform centers (including storage, check-out and presentation areas) tied to a large production, duplication and administrative facility.

The "satellite" microform centers may carry duplicate collections, special discipline-oriented collections, or a combination. On a larger campus, the dis-

ciplinary orientation presents the advantage of physical proximity to those working in that field. "Undergraduate" microform collections might be duplicated at various points on the campus, perhaps near residential and recreational areas.

Another factor potentially speeding this decentralization is the computer: if circulation-type data can be fed in on-line and kept up to date, the potential microform user can be apprised of where the material is when he retrieves the item in an index search. The linking of each satellite center with each other and with the central production and administrative area would allow easy transfer of microform materials from place to place.

MICROFORM CHECK-OUT AND CIRCULATION CONTROL AREA

104

description: This area would accommodate a number of functions:

1. Recording microfilmed materials taken from the center.
2. Receiving returned microforms, after use in the center and after check-out for use outside the center.
3. Receiving requests for microform materials not in the immediate collection, transmittal of these requests to other storage areas, and receipt of microforms from these remote areas.
4. Transmitting requested microforms to other areas.
5. Transmitting requests and receiving microforms from central production and duplication area.
6. General administrative tasks for operating the microform center.

size and configuration: Must be large enough to accommodate a large desk; a computer terminal for recording circulation and making requests (preferably a keyboard and CRT, see A-2); a pneumatic tube station (if transfer with other microform centers is contemplated); and adjacent user seating area. 60-80 square feet per attendant; an additional 100 square feet to seat 5-6 persons waiting for requests to be fulfilled.

location and access: Should be located at the entry point to the microfilm center; direct access to index request areas (see Terminal Area A-6), microform storage area (D-5) and microform presentation areas (D-3).

physical considerations: The check-out area need not be physically separated from the materials storage (D-5). Visual monitoring (glass panels) of terminal areas should be provided, however.

lighting: Standard classroom levels.

acoustics: There are no problems if the CRT-and-keyboard combination is used at the circulation desk; if the noisier printer is used, acoustical baffling of the printer (a partial enclosure) should be provided to keep noise levels down. Private presentation areas (D-3) require full acoustical separation from the public areas.

mechanical: No special considerations; air conditioning would improve comfort (and probably increase utilization) of all microform areas.

D-4 (continued)

electrical: Convenience outlets at base of circulation desk for the various equipment required on it (110v).

communications: Telephone at desk; see D-7 for discussion of pneumatic tube station.

furnishings and equipment: Circulation desk with under-table drawers and files; adjacent (or built-in) computer terminal and pneumatic tube station.

MICROFORM STORAGE AREA

description: Storage, previewing, and inspection area for microformed materials. Depending on the university's approach, materials may include rolls of microfilm, microfiche, aperture cards and other proprietary microforms.

In addition to the storage cabinets, a number of microform readers for staff use will be included in the room or in an adjacent area (see D-3). Some microform production and duplication equipment may be included, or this may be centralized in a production/duplication facility (D-6).

size: Exact size of this area will depend on the microforms (or mix of microforms) used and the quantity kept in the particular storage area. If the NCR HR-fiche are used, for example, a full "library" of 60,000 volumes can be stored in one file drawer. If these high-reduction microforms are used; room dimensions will be primarily controlled by the need to accommodate people; the collection may be strung out (as a card catalogue is now), perhaps 10 or 15 feet long, and 6 or 8 feet wide. If the lower-reduction materials are used (microfilm and standard microfiche), the area for a small library (20,000 reels of microfilm) could grow to 1,000 square feet.

location and access: Direct access to terminal area (A-6), microfilm readers (D-3), and microfilm checkout (D-4). Some readers may face directly on the microfilm storage area for quick-view utilization.

physical consideration: Area need not be fully enclosed; may be joined with checkout area, with terminals and some readers opening off the area in recesses.

lighting: Overall, high quality illumination (60fc) acceptable.

acoustics: Most noise will come from the shuffling of feet, and the opening and closing of drawers. Carpeting is suggested.

mechanical: Air conditioning will insure longevity of microformed materials.

electrical: Convenience outlets for readers.

furnishings and equipment: Drawers or shelving as necessary.

MICROFORM PRODUCTION AREA

106

description: Once the university commits itself to the use of microforms, it must settle upon policies of (1) procurements and (2) duplication. The decisions made on these two points will go a long way in shaping the necessary central production, duplication and handling areas.

If the individual campus is to produce much of its own material, the production capability must be significant. If duplicates are to be stored in the individual collections around campus (and particularly if a pneumatic tube swap system is operating) the central need for duplication will be greatly diminished).

In early years, a university with heavy microform commitments will probably have to plan on much of its production work; in future years, this capability may be exchanged with duplicating capacity. In any case, the space required should not change drastically.

space required: Initial area to serve one or two microform production and duplicating systems (microfilm, microfiche, HR-fiche, aperture card, etc.) probably about 500-600 square feet; expand to 1,000 square feet or as collection grows.

Considering the indefiniteness of these figures, it is suggested that the microform production area be integrated with or adjacent to other media production areas (C-8) and divided from them by demountable partitioning for year-to-year flexibility. If the production area cannot be located in this way, it should back up to a storage area, classroom or other area that might accommodate expansion in time.

location and access: See above. Should be located in the same general area on campus as the main storage and checkout area (to eliminate extremely long cart runs between the two) unless a pneumatic tube system is used. Access should be restricted to qualified staff.

lighting: Standard considerations.

acoustics: Acoustical ceiling should be sufficient.

mechanical: Air conditioned.

electrical: 110v/220v probably required.

D-6 (continued)

furnishings and equipment: Camera stands, duplicators, sorters, mounting equipment as necessary;
work table; supply shelving. Consult manufacturers for templates.

FACSIMILE DISTRIBUTION

description: If a system of central and satellite microform resource centers is contemplated, and if a good deal of microform "swapping" between centers is planned, serious consideration to a pneumatic tube distribution system should be given.

Depending on the complexity of the network, pneumatic installations are of three types:

1. The MANUAL system of feeder tubes to a central "parent" control center, requiring an individual tube from each station and an operator at the control center.
2. The PUSHBUTTON system of feeders into a central control area, where an operator controls origins and destinations of tubes by pushbutton. While a central operator is required, one feeder tube can service up to 10 stations.
3. The FULLY AUTOMATIC SYSTEM where switching is handled automatically; again one feeder will service 10 remote stations.

locations: Remote stations might be in microform checkout areas (D-4), with the central control placed in the central production (D-6) or administrative center.

space required: The sending/receiving stations may be built semi-recessed into partitions or installed free standing. These are generally about 5 feet high, 24"-36" wide and 20"-30" deep. They must be installed at a wall unless the feeder tube is dropped from the ceiling.

Feeder tubes may be 4"-6" in diameter; the only limitations are in bend radii; installation in space above suspended ceiling will allow easy service access.

Central control area will be fairly large and divided into two spaces: a control room (perhaps 100-150 square feet) and a mechanical room (probably same size) for exhaust. If control area is to be manned, standard lighting, acoustics and ventilation requirements prevail.

APPENDIX

The equipment data sheets presented on the following pages illustrate schematic layouts and equipment requirements for a few components of the IBM System/360 line.

The purpose of the illustrations is not to show an "average" or a "suggested" computer configuration and its facilities implications. The intent, rather, is to show the kinds of facilities implications one encounters in planning for computer and computer-associated equipment.

In all cases involving computers, it is mandatory that manufacturers be consulted for layout and template work. If planning and programming take place before specific systems are selected, the guidance on Sheets A-7 to A-12 should be followed, with particular emphasis given to the comments of "flexibility". If the kind of "flexibility" discussed is provided, there should be few problems in accommodating the system finally selected by the university.

SYSTEM/360 MODEL 40

PLAN VIEW

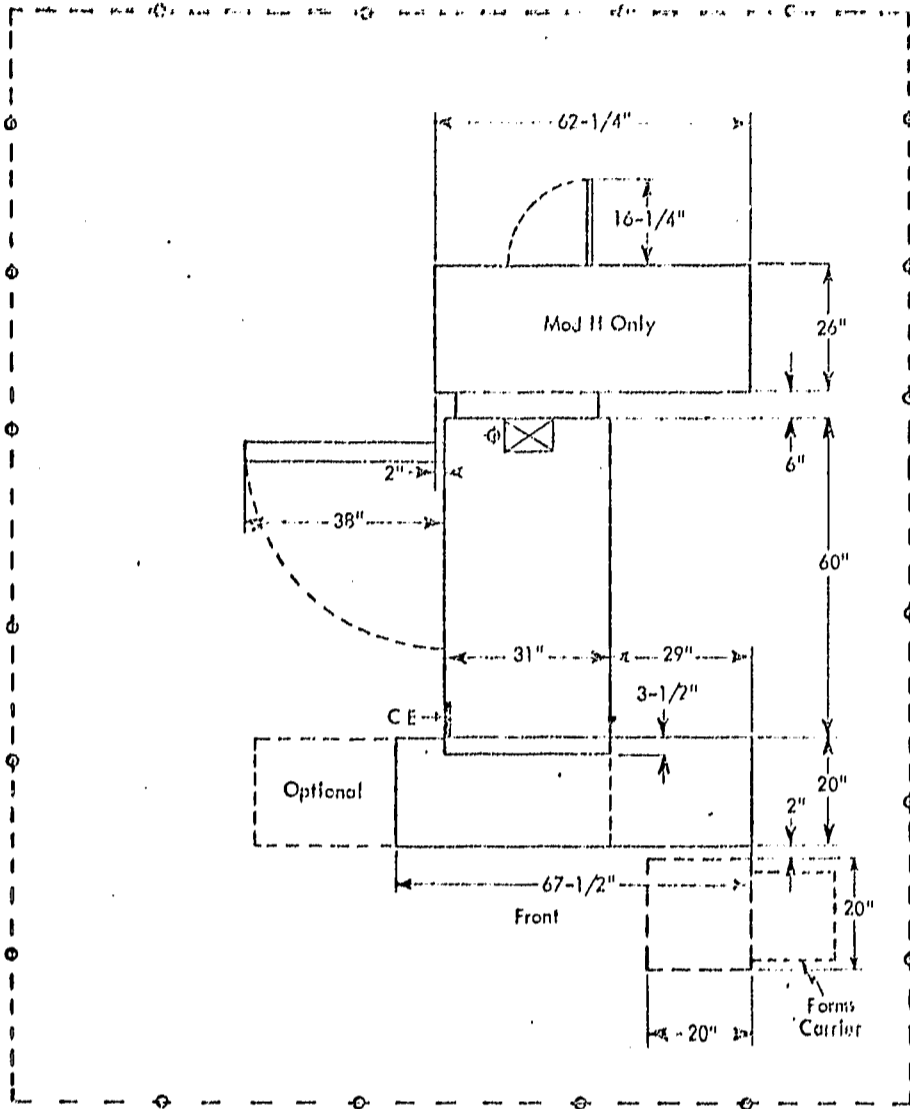

SPECIFICATIONS

Dimensions (inches)

F	S	H
60	109	60*

Service Clearances (inches)

F	R	Rt	L
48	48	30	72

Weight (lb): 1,700

BTU/hr: 7,000

CFM: 300

Power Requirements:

kva	2.5
Phases	3
Plug	R&S, FS3760
Connector	R&S, FS3934

Environment Operating:

Temperature	60-90°F
Rel Humidity	10-80%
Wet Bulb	78°F

Environment Nonoperating:

Temperature	50-110°F
Rel Humidity	10-80%
Wet Bulb	80°F

Notes

* 70" for Model II.

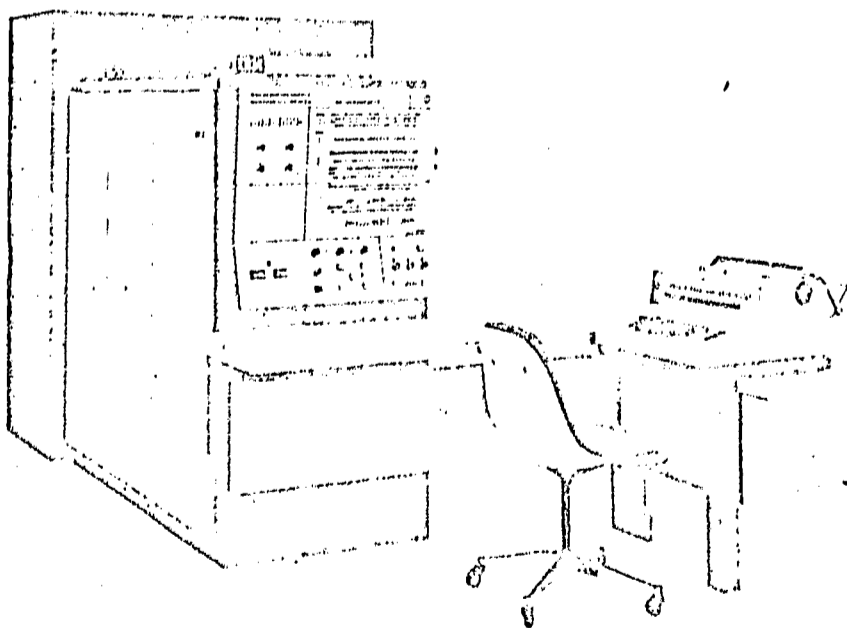

SYSTEM/360 MODEL 75 J

PLAN VIEW

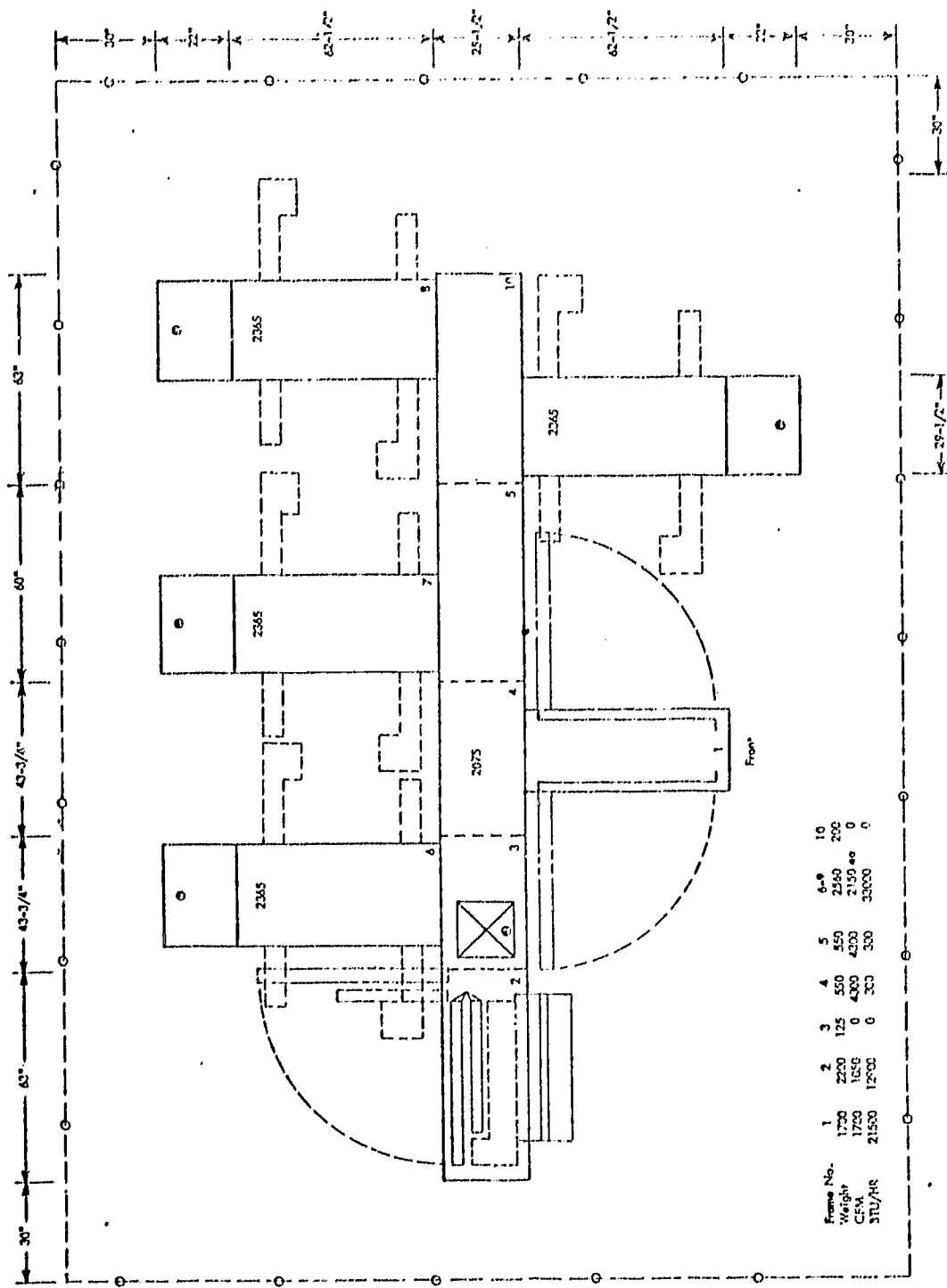

SPECIFICATIONS

Dimensions (inches)

F	S	H
*	*	72-1/2

Service Clearances (inches)

F	R	Rt	L
*	*	*	*

Weight (lb):	2075	2365
	4,575	2,560
BTU/hr:	43,000	33,000
CFM:	3,350	2,150

Power Requirements:

kva	12.6 (2075)	12.5(2365)
Phases	3	
Plug	R&S, SC7328	
Connector	R&S, SC7428	

Environment Operating:

Temperature	60-90 F
Rel Humidity	8-80%
Wet Bulb	78° F

Environment Nonoperating:

Temperature	50-110 F
Rel Humidity	8-80%
Wet Bulb	80° F

Notes:

* See plan view for data

2301 DRUM STORAGE

PLAN VIEW

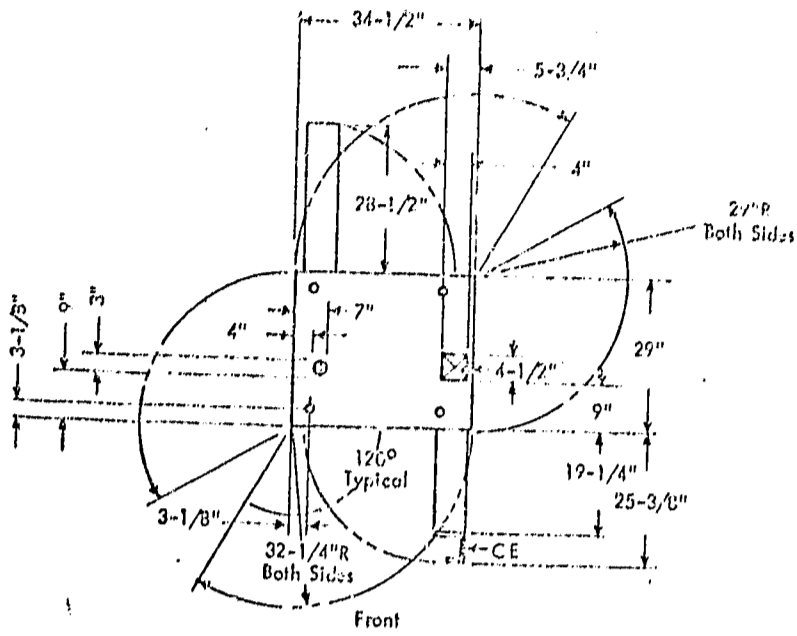

SPECIFICATIONS

Dimensions (inches)

F	S	H
34-1/2	29	64

Service Clearances (inches)

F	R	Rt	L
48	48	42	42

Weight (lb): 850

BTU/hr: 3,800

CFM: 320

Power Requirements:

kva 1.5
Phases 3

Environment Operating: *

Temperature 60-90°F
Rel Humidity 8-80%
Wet Bulb 78°F

Environment Nonoperating:

Temperature 50-110°F
Rel Humidity 0-80%

Notes

* Normal operating conditions must be maintained for 2 hours prior to start of operation.

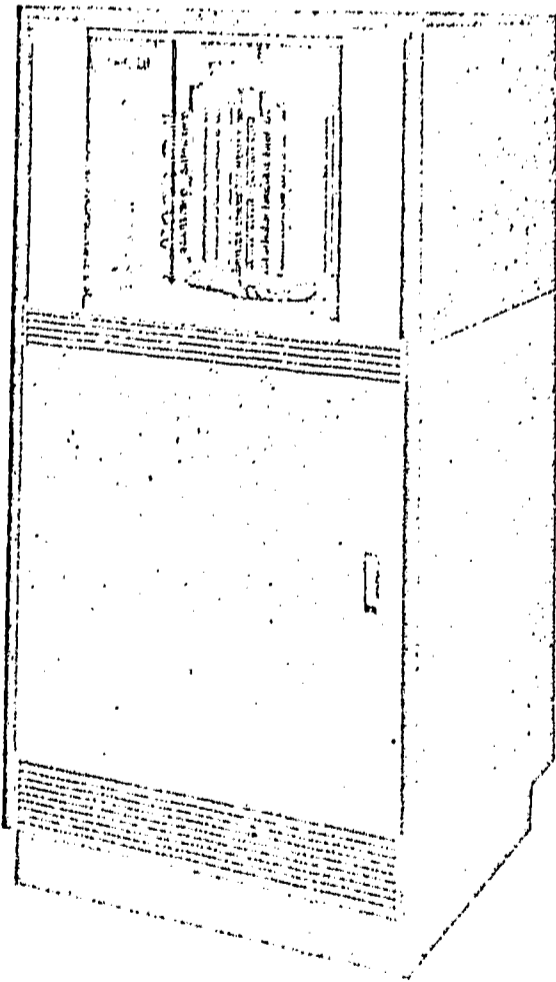

2311 DISK STORAGE DRIVE

PLAN VIEW

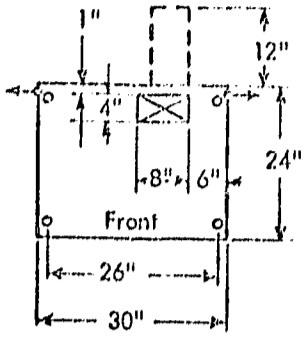

SPECIFICATIONS

Dimensions (inches)

F	S	H
30	24	38

Service Clearances (inches)

F	R	Rt	L
36	36	30**	30**

Weight (lb): 390

BTU/hr: 2,000

CFM: 100

Power Requirements:

kva 0.75

Environment Operating:

Temperature 60-90°F

Rel Humidity 8-80%

Environment Nonoperating:

Temperature 50-110°F

Rel Humidity 0-80%

Notes

- * Powered from control unit.
- ** When abutted to units of like construction.

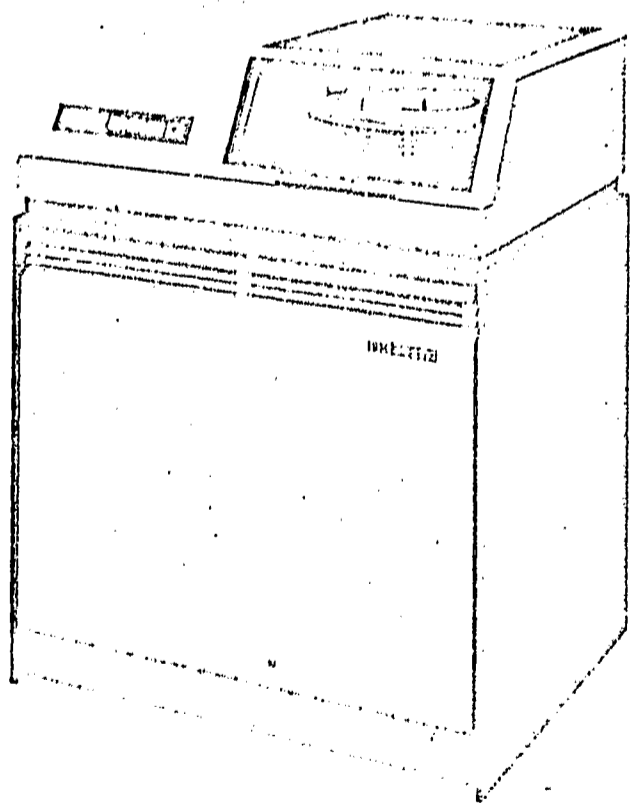

2321 DATA CELL DRIVE MODEL 1

PLAN VIEW

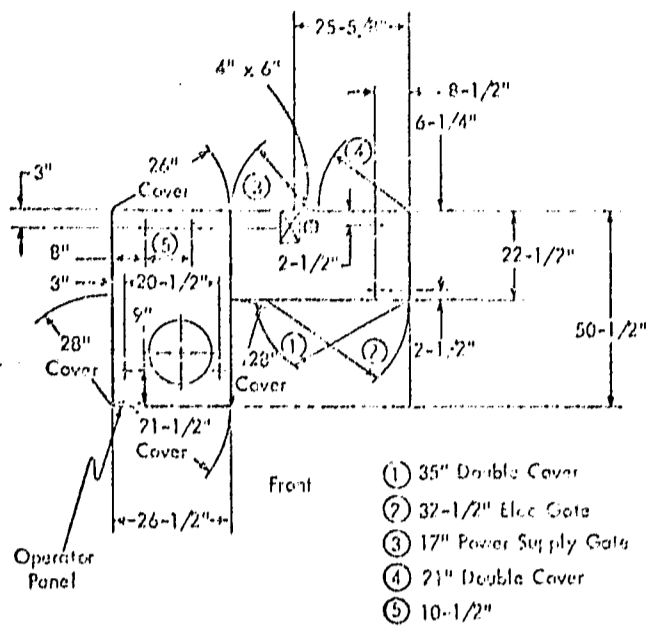

SPECIFICATIONS

Dimensions (inches)

F	S	H
68-1/2"	50-1/2"	60

Service Clearances (inches)

F	R	Rt	L
30	30	34	30

Weight (lb): 1,950

BTU/hr: 19,500

CFM: 850

Power Requirements:

kva	8.7
Phases	3
Plug	R&S, FS3760
Connector	R&S, FS3934

Environment Operating:

Temperature	65-90°F
Rel Humidity	20-80%
Wet Bulb	78°F

Environment Nonoperating:

Temperature	50-110°F
Rel Humidity	8-80%
Wet Bulb	80°F

Notes

* Reducible to 26-1/2 by 50 inches and 23 by 42 inches for shipping.

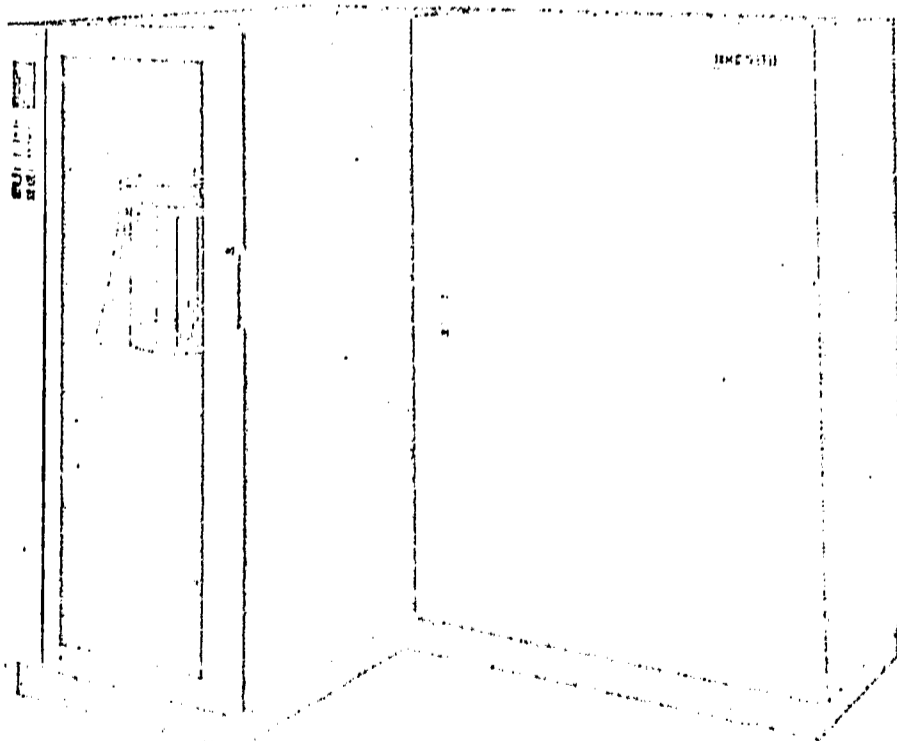

7404 GRAPHIC OUTPUT UNIT

PLAN VIEW

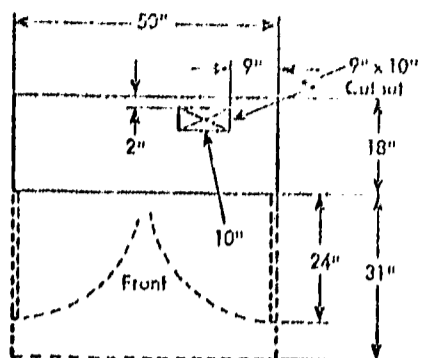

SPECIFICATIONS

Dimensions (inches)

F	S	H
50	18	81

Service Clearances (inches)

F	R	Rt	L
42	30	30	30

Weight (lb): 800

BTU/hr: 3,000

CFM: 200

Power Requirements:

kva *
Phases 1

Environment Operating:

Temperature 50-90°F
Rel Humidity 8-80%
Wet Bulb 78°F

Environment Nonoperating:

Temperature 50-110°F
Rel Humidity 8-80%
Wet Bulb 80°F

Notes

* Powered from control unit.

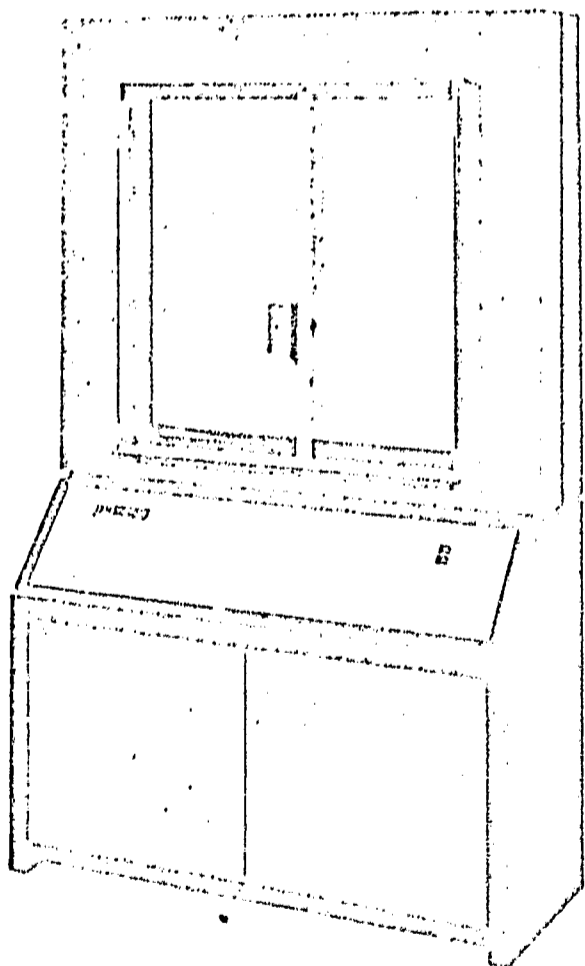

7770 AUDIO RESPONSE UNIT MODEL 3

PLAN VIEW

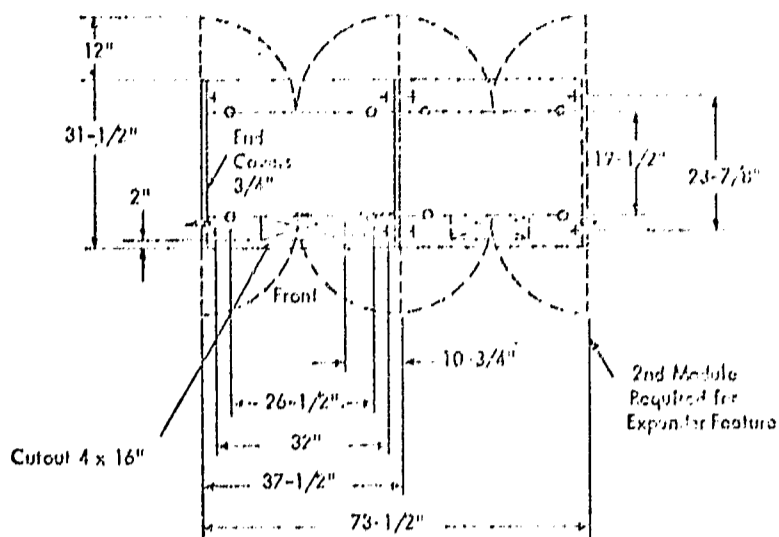

SPECIFICATIONS

Dimensions (inches)

F	S	H
37-1/2"	31-1/2"	70"

Service Clearances (inches)

F	R	Rt	L
42	36	30	30

Weight (lb): To 16 Lines 500 To 48 Lines 1,000

BTU/hr: 3,000 6,000

CFM: 400 800

Power Requirements:

kva	1.6 (16)	2.5 (48)
Phases	1	
Plug	R&S, FS3750	
Connector	R&S, FS3933	

Environment Operating:

Temperature	60-90°F
Rel Humidity	20-80%
Wet Bulb	78°F

Cable Limitations:

40 feet of cable to the common carrier.

Notes

*73-1/2 inches with expander feature.

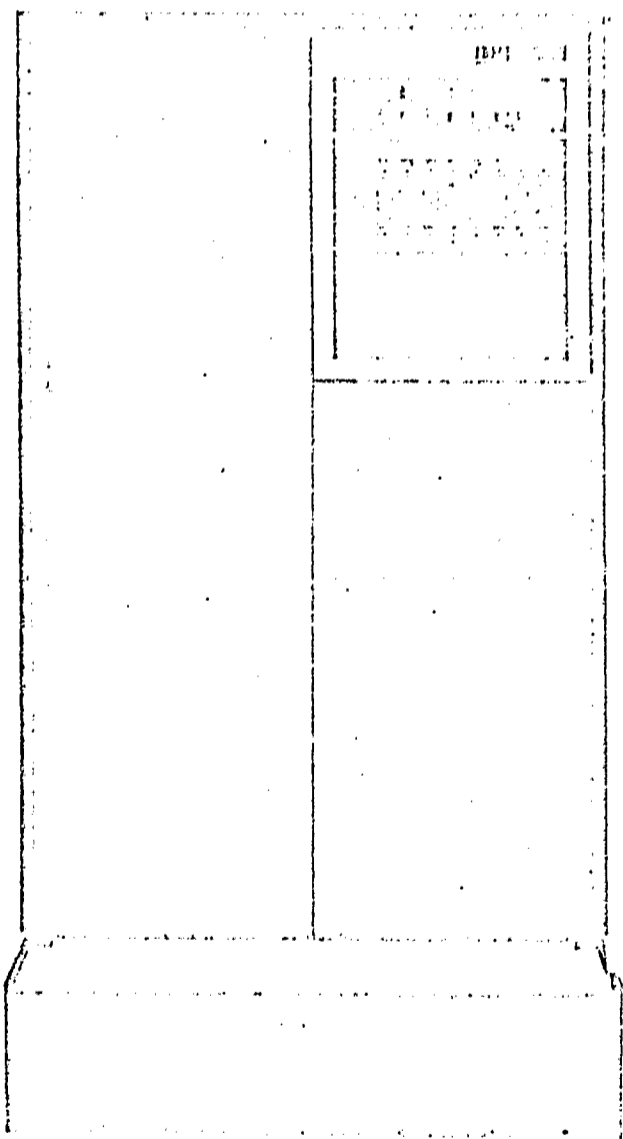

Even in the face of current emphasis on developing systems to distribute audio, video or audio-video materials (via broadcast, television, computers, etc.) from source to user, user-handling of audio-video resources will always be important. Already non-distributed audio-video resources have seen widespread use on many campuses, particularly in lectures and other group presentations. As the materials become more plentiful, and as equipment to play or project them becomes cheaper and more portable, it is probable that the use of non-distributed resources will become even more popular.

the materials

Audio-video resources used by students, faculty, researchers and even administrators on campus may include,

- 2 x 2 slides, individually or in drums or trays
- 3-1/4 x 4 slides
- overhead transparencies, individually or in long rolls
- motion pictures, on reels or in self-rewinding cartridges
- filmstrips and sound filmstrips
- audio tapes, often with multiple tracks for additional recording or audio-comparing
- video tapes, with or without sound
- miniaturized learning aids and machines
- a-v programmed instruction devices

These materials now cover thousands of topics and may be of any length

(although the trend is toward shorter, single-concept presentations). They may be commercially produced or made on campus, perhaps by the user himself. Purchase and duplicating costs are steadily decreasing, and the time is not far away when these kinds of materials may constitute a truly significant part of the university's collection of resources.

the equipment

Most audio, video and audio-video materials require a piece of equipment for listening, recording or viewing. The past decade has seen the development of inexpensive, durable, lightweight, portable, and easy-to-use devices for all of these functions. It is conceivable that the university of the 1970's will have a large supply of this equipment for all types of use.

the users

The most common user of non-distributed audio-video resources will undoubtedly be the student. Use may be dictated by programmed learning sequences, course outlines, research work, or simply recreational needs. Faculty, staff, and administrative uses for learning, reviewing, and selection of materials, while less frequent than student uses, must be considered in planning and programming.

use by individuals and in small groups

Non-distributed resources may be used in many different ways. First, it is possible that individuals or small groups may provide both materials and equipment, simply seeking access to individual or small-group areas suitable for listening, recording, or viewing.

Secondly, individuals or small groups may provide their own materials, but need equipment for presentation. These devices may be built-in in viewing/listening/recording areas, or it may be necessary to check them out from a central store.

Thirdly, individuals or small groups may desire to check out both materials and equipment, and take them to places suitable for their use.

Finally, the individual or small group may desire to produce inexpensive audio and audio-video resources.

The complement of facility types presented on Facility Data Sheets B-1 to B-5 and B-7 to B-10 should be adequate to accommodate any of these use patterns.

use in large groups

The use of these aids and media in large groups is already a common occurrence on campus. Traditional lectures are being supplemented with or even fully-presented with the use of slides, transparencies, models, motion pictures and so-on.

Considering the wealth of documentation on the facilities requirements for using aids and media in large groups, Facility Data Sheet B-6 presents only a check list of factors for programming consideration.

presentation areas

Spaces must be provided which allow students, faculty and others on campus to bring in audio and audio-video resources for use and review. These should include a mixture of,

- spaces for individual interaction with audio materials
- spaces for individual viewing and listening to video and audio-video materials
- spaces for small group interaction with and discussion of audio materials
- spaces for small group listening, viewing and discussion of video and audio-video materials
- spaces for medium and large group uses.

the carrel

The individual spaces may be thought of as variations on a basic individual study space, perhaps a carrel or a fully-enclosed cubicle. These spaces will be provided throughout the campus. Some will be "dry" (no electrical service); others will be wired for power for hand-carried equipment; still others may include built-in listening and viewing devices.

Advances in the portability of these listening and viewing devices suggests that it may be rarely necessary to build in a great deal of this equipment. This approach also allows greater flexibility of carrel use. It does, however, presume the existence of central materials and equipment check-out areas.

Variations on basic carrels for individual use of audio and audio-video resources are presented on Sheets B-1 and B-3.

small group areas

Traditional approaches to providing space for using non-distributed resources usually neglect the small-group. While the actual amount of small group use will vary with the university's educational philosophy, the use of this approach to present and discuss instructional units will be significant on many campuses. Facilities implications are presented on Sheets B-2 and B-4.

location of presentation areas

These individual and small group presentation areas may be located throughout the campus. Some should be clustered around the materials and equipment check-out areas to allow easy use. Others may be spread about academic, residential and recreational areas.

INDIVIDUAL AUDIO PRESENTATION /RECORDING AREA

description: The individual user may check out an audio recording (on tape or in phonograph form) for listening, recording, audio-compare, or in a combination of these modes. He may take this to an individual listening/recording area already furnished with the playback device, or he may check this device out, too.

In the case of phonograph recordings, the playback device is most likely to be built into the presentation area; it is up to the individual campus whether it will accommodate the lending of phonograph records, or whether it will transfer these to the medium of audio tape.

In the case of audio tape recordings, the continued development of small, portable devices for recording/playback and audio-compare suggests that the university may want to resort to user check-out of both recording and recording device. This approach will reduce the expense of building in equipment, and will increase utilization of presentation/recording areas.

physical form: A traditional approach to a presentation/recording area has been the provision of individual carrels and rooms for these activities. If the noise problem is adequately handled (see "acoustics"), there is no reason why these areas need to be fully enclosed.

size and configuration: The area must be large enough to accommodate a working surface (for both equipment and note-taking) and the user himself. Unless equipment of unusual size and proportion is to be built-in, individual areas can be as small as 5' wide and 4'-6" deep (22.5 square feet). If areas are to be enclosed on the user's rear side, they should probably be a full 5' deep (25 square feet).

locations: Where no devices are built into the carrels, they should be located fairly close to the central check-out area in order to minimize distances for carrying media and equipment. (Certainly 100'-150' does not seem like a long distance to ask students to walk).

Carrels or cubicles equipped with audio presentation/recording devices may be scattered about academic and residential areas since the audio cartridges are small enough to be hand-carried some distance. Ease of maintenance suggests that these be clustered into small groups (perhaps combined with other request/presentation devices in various areas).

Direct supervision or circulation control of these carrel areas is not required; 24-hour access should be feasible.

B-1 (continued)

access: Doors (with glass vision panels for supervision) should be used where carrel areas are accessed from well-used circulation areas or other noisy areas.

lighting: Standard classroom levels suggested for overall illumination; possibility of providing an individual carrel-or-cubicle lighting strip, about 24" above working surface should be considered. Panel sources of light (as opposed to point sources) in the ceiling will allow greater flexibility of carrel arrangements.

acoustics: Since the user may be speaking, acoustics should be a significant design factor. The use of headsets will eliminate loud speaking, but the ceiling of the carrel area, and the individual carrel dividers should be treated with sound absorbing materials. Carrel areas should be fully isolated from external noise (as any classroom would). The possibility of providing some fully-enclosed cubicles should be considered (sometimes it is desirable to "fill" an area with recorded music, rather than listen to it through earphones).

mechanical: Standard ventilation required; if any fully-enclosed areas are provided, care should be taken to vent all cubicles.

electrical: Where equipment is not built in, convenience outlets for 110v should be located at working height levels (just above the table top). Even where equipment is built-in, an additional convenience outlet at this level should be considered.

furnishings and equipment: Tabletop working surface, temporary books and notes storage, coat hook.

general design consideration: Traditionally it has been easy to group all carrels into one location without further consideration for scale or comfort. Particularly on campuses where students will be asked to spend a good deal of time in these situations, the design and layout of carrels and carrel areas should be approached with real care.

"Row-on-row" arrangements should generally be avoided as of improper scale and uninviting to use; clever arrangements, where perhaps "only a few carrels can be seen at once" would seem more inviting. The possibility of including small (100-150 square feet) "soft reading" areas in or adjacent to carrel areas (for relief) should be considered.

SMALL GROUP AUDIO PRESENTATION / RECORDING AREAS

description: Occasionally it may be desirable to have a small group listen to, record, and play back audio recordings (either in phonograph record or in audio tape form). The presentation/recording device may be built-in or checked out from a central equipment store.

physical form: A fully-enclosed room should be provided.

size and configuration: Size will, of course, depend on the number of users to be housed. A room of 80 square feet will easily house 6 people. (The possibility of equipping this area, or allowing access into this area, of a media presentation module, B-4, would increase utilization of this area).

locations: Should be in the general vicinity of the check-out area in order to allow staff scheduling and (indirect) supervision of these areas.

access: Visual access (glass panels, or glass lights in door) should be possible for "monitoring" purposes, and to see if the room is in use.

lighting, mechanical: Standard considerations.

acoustics: If it is felt necessary to eliminate full acoustical enclosure for reasons of control or supervision, group rooms should not be located adjacent to noisy circulation areas.

electrical: Several convenience outlets should be provided (110v).

furnishings and equipment: Table and chairs as required; chalkboard surface should also be included. Coat hooks for users. Carpeting would be a nice-but-unnecessary addition (for acoustics and additional seating).

INDIVIDUAL VIEWING/LISTENING AREA

description: Individual users may check out any number of projected materials and/or viewing equipment from the central check-out area and take them to some individual viewing/listening area.

In the case of 2x2 slides, the user may check out the slides and a small hand viewer or small projector with self-contained rear screen. In the case of 8mm film cartridges, he will check out the cartridge and a small, portable sound-and-image projector (with self-contained rear screen or with an additional portable rear screen).

While it is possible to build in the viewing equipment, with user check-out of only the viewing medium, the size, portability and ease of using new projection devices suggests that the check-out of device is not only feasible, but probably desirable in terms of utilization.

physical form: The traditional approach has included the provision of carrels and individual cubicles for listening and viewing. Full enclosure is not necessary, however (see "acoustics").

size and configuration: The area must be large enough to accommodate a working surface for both equipment and note-taking. Unless equipment of unusual size or proportion is to be built-in or used, individual areas may be 5' wide by 4'-6" deep (22.5 square feet) or 5' x 5' when fully enclosed (25 square feet).

location: Fairly close to check-out areas. If satellite check-out areas are maintained for the most highly-used materials, clusters of individual viewing/listening areas can be set up around them.

Carrels equipped with built-in (or permanently attached) projection equipment may be scattered throughout academic and residential areas, particularly where the film cartridges are used.

Direct supervision or circulation control of these carrel areas is not required; 24-hour access should be possible.

access: Doors (with glass vision panels for supervision) should be used where carrel areas are accessed from well-used circulation areas or other noisy areas.

B-3 (continued)

lighting: Standard classroom levels suggested for overall illumination; point sources of light should be avoided since they restrict carrel flexibility and may cause undue glare on viewing screens. Adjustment of lighting levels for image viewing is unnecessary in this situation.

acoustics: See B-1.

mechanical: Standard ventilation required; if any fully-enclosed areas are provided, care should be taken to vent all cubicles.

electrical: Where equipment is not built in, convenience outlets for 110v should be located at working height levels (just above the table top). Even where equipment is built-in, an additional convenience outlet at this level should be considered.

furnishings and equipment: Tabletop working surface, temporary books and notes storage, coat hook.

general design considerations: See B-1.

SMALL GROUP VIEWING/LISTENING AREA

description: A small group may want to check out an audio-visual item (a set of slides, a set of overhead transparencies, a film cartridge), take it (and possibly the equipment) to a small group viewing/listening area to see and discuss the presentation.

The projection equipment and screen may be permanently (or semi-permanently) installed in the area in the form of a media module as shown overleaf. The user may bring a portable projector into the room with him.

physical form: A fully-enclosed room should be provided.

size and configuration: Size will depend on the number of users to be housed, although a room of 80 square feet will accommodate a group of 6 (8' x 10').

Configuration should take the form of a square to accommodate the most efficient viewing area for projected media, as shown overleaf. Design should allow corner placement of viewing surface (screen) in order to "fit" the maximum viewing area to the room.

location: Should be in the general vicinity of the check-out area in order to allow staff scheduling and (indirect) supervision. There will be other areas on campus (small-group seminar and conference rooms) that will also accommodate this activity.

access: Visual access (glass lights in the door; large glass panels should be avoided due to the ambient light problems) should be provided.

lighting: It will be necessary to darken the area when front projection techniques are employed; some wall lighting (directed down against the walls to avoid interference with projection beam or screen) should be considered to keep the room from plunging into total darkness. Use of the rear-screen media module does not require room darkening if room lights do not shine directly on screen.

acoustics: If it is felt necessary to eliminate full acoustical enclosure for reasons of control or supervision, group rooms should not be located adjacent to noisy circulation areas.

B-4 (continued)

mechanical: Standard considerations.

electrical: Several convenience outlets should be provided (110v).

furnishings and equipment: Table and chairs as required; small table or shelf to accommodate projector (for front projection); front projection screen; media module (perhaps shared with other areas); chalkboard; coat hooks; carpeting a nice-but-unnecessary addition.

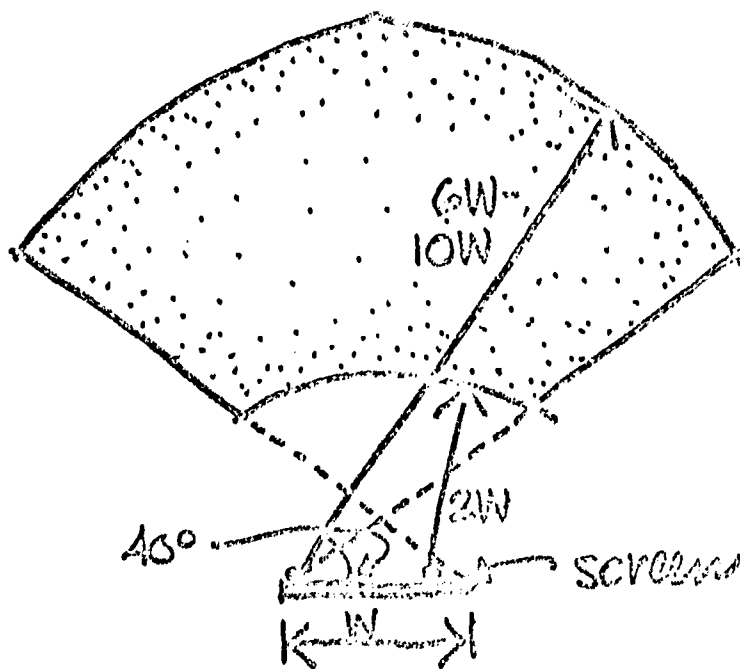

OPTIMUM VIEWING AREA FOR PROJECTED AIDS
AND MEDIA

B-4 (continued)

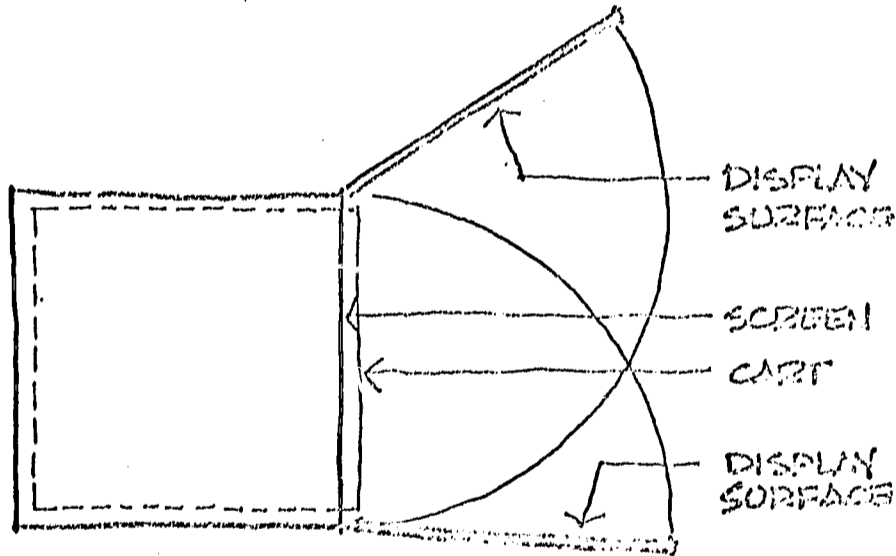
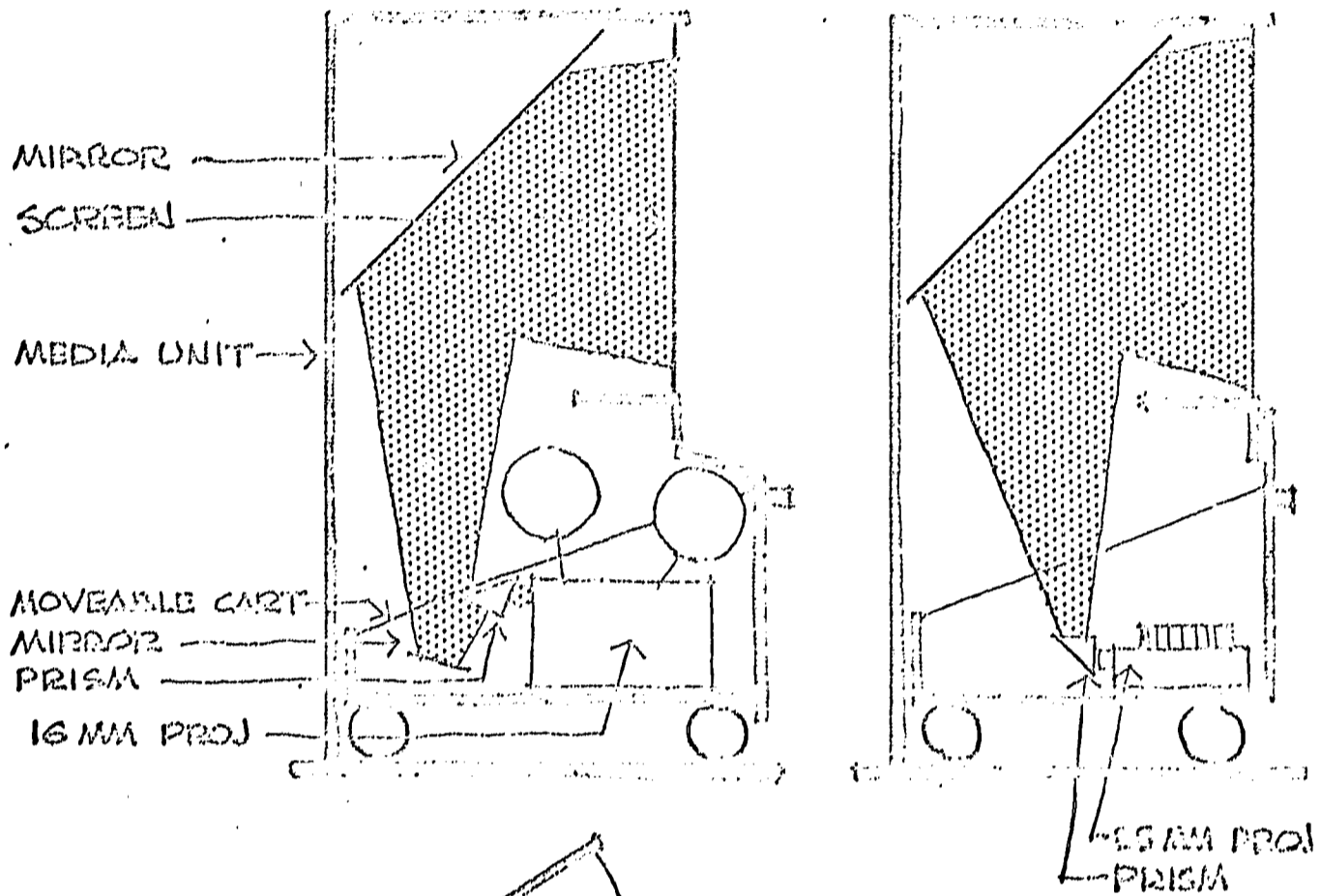

MEDIA
MODULE
DETAILS

SPECIAL PRESENTATION/MANIPULATION AREA

description: The use of some audio-video resources, notably some programmed instruction devices and some miniaturized learning devices (small computer trainers, miniature chemistry laboratories, etc.) may require special presentation/manipulation areas or carrels.

size and configuration: The need to accommodate more apparatus than other audio-video carrels suggests a somewhat enlarged working surface; a 6' x 5' area (30 square feet) may be required.

location and access: These areas should be provided in the vicinity of the areas where the audio-video resources may be checked out. This suggests placement near central materials and equipment storage areas (B-7 to B-9). Special carrels for scientific uses (requiring air, water, or gas) may be located in the vicinity of a materials and equipment center dedicated to science instruction or research.

Visual access (through glass panel or lights in the door) should be provided; areas do not require direct supervision, but should be set up for indirect monitoring and scheduling.

Clustering of carrels will make monitoring easier and will economize on special services.

physical considerations: The need for individual concentration, and the possibility of producing noise and odor, suggest that the fully-enclosed cubicle might be the most appropriate physical form.

lighting: Standard levels.

acoustics: Full enclosure is suggested; noise levels produced will not be abnormal, however.

mechanical: Individual ventilation required; possibilities of direct exhaust in science-oriented areas should be considered. Special services (air, gas, water) may be required in science carrels.

electrical: One or two convenience outlets (110v) at table-top height.

furnishings and equipment: Large working surface; small sink a possibility in science carrels; temporary storage for books; coat hooks.

LARGE GROUP VIEWING/LISTENING AREAS

B6

The need to consider the use of audio-video resources, both distributed and non-distributed, is fundamental to the design of large group spaces. The following is by no means a comprehensive summary of programming information (which is easily available elsewhere), but is a summary of planning and design considerations:

1. The kinds of images, the means for projecting them, and their size will control the capacity of the room (and vice versa).
2. Projected images dictate optimum configurations of seating areas.
3. Good viewing demands floor sloping or stepping in large rooms (50-80 or more).
4. Design and location of display surfaces for maximum use and flexibility is critical.
5. Lighting levels on task surfaces (when media are being projected) must be carefully coordinated.
6. Ambient lighting on screens must be carefully controlled.
7. The need to darken these rooms suggests that windows are often liabilities rather than assets.
8. Design for good acoustics is important; parallel walls are often avoided.
9. Control of equipment noise is important.
10. The need to cool large group spaces is fundamental.
11. Seating must be carefully designed; countertop writing surfaces for taking notes are often provided.
12. The need for sound systems must be carefully reviewed.
13. The selection and installation of projection components (projectors, screens, controls) must be accomplished in a coordinated way.
14. Space for rear projection of images may be necessary.
15. The inclusion of student response units, and teacher readout, must be discussed.

B-6 (continued)

16. The design of teacher lectern and controls must be simple and accomplished with the user in mind.
17. Technical support for media-oriented spaces must be provided in some way.

the check-out suites

The check-out suite for individual and small-group check-out of audio-video resources logically includes a central materials area, an equipment area and an "over-the-counter" check-out area. These are presented in detail on sheets B-7 to B-9.

The approach to providing this suite of facilities will vary from campus to campus, and even perhaps from time to time on the same campus,

- o one central suite may be provided, perhaps as part of the university's library, OR,
- o several suites may be provided with the same basic store of materials and decentralized for user convenience, OR,
- o several suites may be provided, each specializing in one or more disciplinary areas and each located in conjunction with other academic spaces for that discipline.

These storage and support functions should be administratively tied to the management of the university's overall information store (or library). The possibilities of relating the user-oriented materials and equipment areas to campus-wide materials and equipment storage areas should be carefully considered.

production

The projected increases in the use of audio-video resources on campus will inevitably create the need for local, "quick-and-dirty" production areas for student, faculty and staff use. These are presented on Sheet B-10.

Backing up these local areas will be a large campus-wide instructional resources service.

GENERAL AUDIO-VIDEO CHECKOUT AREA

B 7

description: This area serves as the interface between user and the central store of materials and equipment. Requests are received (by telephone, mail, or in person), requests are fulfilled and bookkeeping accomplished in this area.

physical form: In a large audio-video center, a check-out area with an adjacent administrative office area; both functions may be combined in a smaller center.

size: 150 square feet is sufficient for check-out area; add 60 square feet for each staff member projected.

location: The check-out area should be immediately obvious to the casual visitor in the audio-video materials and equipment center.

Location of the storage suite should be carefully considered. Placement should be along major circulation routes to, from and within academic areas serving the bulk of the university's students.

In large multi-disciplinary universities, the possibilities of satellite storage areas (perhaps part of disciplinary resource centers and libraries) should be carefully considered.

access: Access to user area should be as direct as possible, with service counter and full-length door openings into reception area (or corridor recess). Users are not permitted to enter the check-out area.

Direct physical and visual access (glass panels) between checkout and administrative areas (if the two are separated); direct access to material and equipment areas is necessary.

lighting: Standard office levels.

acoustics: Administrative areas should be protected (by full enclosure) from circulation noises in all but the smallest installations.

mechanical and electrical: No special considerations.

B-7 (continued)

furnishings and equipment: Shelving for temporary storage of materials and equipment on their way in or out of the center; large service counter; files; on-line computer terminal for circulation purposes; tackboard; desks and chairs. 1

CENTRAL AUDIO-VIDEO MATERIALS AREA

B 8

description: Storage of audio-video materials for user checkout, possibly including overhead transparencies, slides, cartridge films, and miniaturized learning kits and apparatus.

size: See B-9.

layout: As in the equipment area, the layout for storing the various materials will evolve through use. Since there will be a need to access all the materials in the room, configuration should be simple and square (not long and rectangular, with some portions of the area dozens of feet from the access).

location: See comments on location of the central audio-video storage suite, B-7.

access: Direct access to both check-out and equipment storage areas. Convenient access (perhaps through equipment area) to loading dock or freight elevator.

lighting: Even lighting of high quality (60-80fc) throughout.

acoustics and electrical: Standard considerations.

mechanical: Air conditioning will make storage of some materials easier and probably prolong their useful life.

furnishings and equipment: Large quantities of shelving, storage drawers and file cabinets; table with light box for inspection, review, etc; possibly some minor repair equipment (splicer, etc.).

CENTRAL AUDIO-VIDEO EQUIPMENT AREA

description: Storage of portable projection and audio apparatus for user borrowing.

size: Size will be a problem, for the university's initial supply of equipment will be limited. Use, familiarity, and advances in equipment design and miniaturization should serve to increase the quantity of equipment needed.

One approach to flexibility of size is to combine the equipment area, the materials area (B-8) and a large storage area into one large "room" divided by demountable partitions (year-to-year flexibility). Another approach is to limit the size of the central equipment and materials areas, adding new satellite (or primary) areas as the university expands.

layout: The layout of the equipment area will evolve through use; the need for a piece of equipment "in a hurry", however, suggests that the fastest-moving items will be placed nearest the door to the check-out area; the designer should not restrict layout possibilities in this area of the room.

location: See comments on location of central audio-video storage suite, B-7.

access: Direct access to both check-out and materials storage areas. Direct double-door access to loading deck, freight elevator, etc. for receiving of equipment.

lighting, acoustics, mechanical: Standard considerations.

electrical: Generous supply of convenience outlets (110v) for testing.

furnishings and equipment: Large quantities of shelving on walls and free-standing; work bench and tool rack for minor repairs.

LOCAL AUDIO-VIDEO PRODUCTION AREA

description: A small area for "quick-and-dirty" audio-visual production by faculty, staff, and students. Activities may include the making of large drawings, overhead transparencies, mounting of 2 x 2 slides, dry-photo copying of information, etc. In some cases, a small darkroom or two may be located in the vicinity of the local production area.

size and configuration: A room of 8' x 10' size (80 square feet) will accommodate 15 lineal feet of table-top working surface and 2-3 users at any time.

location and access: These areas might best be located within academic office complexes (for faculty-staff use, and for secretarial supervision), but closely related to student waiting areas (for convenient student access). A production area or two may also be located within the university's information store.

In any case, access should at least be visually controlled by a university staff member (a departmental secretary will do).

lighting: Only becomes critical if a darkroom is added to the complex.

mechanical: Direct ventilation; exhaust fan should be considered.

electrical: Generous supply of convenience outlets (110v) at table-top height.

furnishings and equipment: Continuous table-top surface for working and for equipment; lockable drawers under some of the surface; temporary book storage; coat hooks; chairs and wastebaskets. If a sink is not available nearby, one should be provided in the production area.

4

DISTRIBUTED
AUDIO-VIDEO
RESOURCE SYSTEM

The introduction of the radio in the early twentieth century demonstrated the potential of distributing information to great masses of people. Since that time, television has established itself as a far more versatile medium -- both in the home and in the educational institution.

The university campus of the 1970's will include a number of (possibly interconnected) audio and audio-video distribution systems. Some may be limited to one room or suite of rooms (such as the audio laboratory) while others may extend far beyond the boundaries of the campus (as in the case of the campus TV station). Possible systems include,

- audio laboratory (audio material received at various stations controlled by master console)
- closed-circuit television, with many origination points on campus (including off-the-air)
- local closed-circuit television, with origination and presentation in the same place
- video laboratory (television camera, recorder and monitor for recording and criticizing activities)
- campus television station
- campus radio station
- general access to commercial radio and television
- dial-access of ready-stored audio and audio-video materials

the uses

Distributed audio and audio-video materials will have a variety of uses in the

university environment, including,

- lectures and presentations for student and teacher review
- presentation of single-concept instructional units
- presentation of events of current or historical note
- presentation of programmed instruction packages
- audio training activities (language, speech, drama)
- video training activities (speaking, drama, practice teaching, etc.)
- familiarization with procedures
- teacher review of materials
- recreation

systems components

Like the computer resource system, the various distributed audio-video systems consist of three major components:

- o the REQUEST/PRESENTATION NODES, or devices that allow the user access and display.
- o the CENTRAL EQUIPMENT AREAS, which store and distribute the information; in the case of dial-access, the central area also processes and fulfills requests.
- o the CENTRAL SUPPORT FUNCTION, including administration, scheduling and production or conversion of materials.

All of these components are tied together by some sort of distribution network.

types of access

It is important to realize that there are also three generic ways of accessing these audio-video distribution systems,

- SCHEDULED ACCESS, where the information is pre-mounted on a tape deck or recorder and is activated according to a predetermined schedule. The user must be provided with a schedule of programs and times. All commercial broadcast stations work in this way; in addition, audio laboratories and dial-access systems may be utilized in this fashion.
- MANUAL ACCESS, where the program is mounted by direct user request. This is often the case in campus-wide closed circuit TV networks, some audio laboratories, and some dial-access setups.
- RANDOM ACCESS, where the user can access any pre-mounted audio or audio-video program by simply dialing a number. The dial-access system is the only set-up with this capability.

campus-wide systems

Audio-video materials distributed campus-wide can be requested from and presented in a variety of areas:

- The home, dormitory or recreational area via the radio or television set. Since the facilities in which these devices are placed are not specifically designed for them, formal Facility Data Sheets have not been developed.
- Classrooms and other academic areas where television is used as a teaching medium. Special facility implications are noted on Sheet C-4.
- Individually to students in carrels. Sheets C-1 and C-3 present facilities planning data for these installations. The reader will note that they are simple variations on carrel areas for non-distributed audio-video media. The prime difference, of course, is location: the carrel wired for distributed audio or audio-video resources has far greater potential location than one which is tied to a materials and equipment checkout area.
- Group viewing areas, where small or medium groups can remote access audio-video materials, interact with them and discuss them as necessary. See Sheets C-2 and C-4.

"limited" systems

As suggested in the introduction to this Part, some of the university's distributed audio-video resource systems may be limited to one or two rooms. A traditional example is the oft-used and oft-abused audio laboratory (or "language laboratory" as it is fondly known to millions). Here a central console may broadcast one program, or a number of programs through audio loops or direct wiring to a number of student stations. The person at the master console may have a variety of alternatives in program control, monitoring, etc. This laboratory is briefly discussed on Sheet C-5.

Another approach gaining some popularity is the "video laboratory". Here a self-contained complement of camera, video tape recorder, and monitor is used for a variety of learning situations where it is beneficial for the user to "see" himself or others in action. The video laboratory may be a separate room where scenes are enacted, it may be a small area adjacent to a classroom or dramatic stage where the camera sits behind one-way glass, or the camera may be fully remote from recorder and monitor. Facilities implications are presented on Sheet C-6.

INDIVIDUAL AUDIO PRESENTATION/RECORDING STATION

description: This is essentially a carrel (such as that described for non-distributed audio on Sheet B-1) which is wired into an audio-video distribution system. Basic equipment includes a set of headphones, a dial or channel selector, and a remote "record-erase-playback" control switch.

location: Since use of this area does not depend on physical proximity to a central check-out area, carrels for distributed audio can be placed anywhere on campus. Probable locations include within academic and residential complexes (in study or other public areas) and in any other areas where students may wish to "stop off" for some remote retrieval of audio information (such as in the student union). Some clustering of stations makes maintenance easier and may shorten wiring runs.

all other aspects: See Facility Data Sheet B-1.

GROUP AUDIO PRESENTATION/RECORDING STATION

description: Small, medium and large groups may desire remote access to audio information. This may be accomplished in a small group area (such as that described for access to non-distributed audio resources, B-2), or an audio station may be located in a medium- or large-group academic space. Basic equipment includes headphones (perhaps a jack strip for multiple headphones) or speaker, dial or channel selector, and remote audio controls ("record-erase-playback").

size: An audio station may be incorporated in a room of any size; Sheet B-2 describes a small group room for 6 people.

locations: These rooms may be placed anywhere on campus. Small group rooms dedicated to this use may have to be placed so they can be visually supervised and scheduled. Some clustering of stations makes maintenance easier and may shorten wiring runs.

all other aspects: If a small-group room, see B-2. If a large-group room, note considerations on Sheet B-5.

C3

INDIVIDUAL VIEWING/LISTENING STATION

description: This is essentially a carrel (such as that described for non-distributed viewing/listening on Sheet B-3) which is wired into an audio-video distribution system. Basic equipment includes a dial or channel selector. The TV set may be built-in, or attached to the carrel by a power cord (security probably dictates the former).

location: Since use of this area does not depend on physical proximity to a central check-out area, carrels for distributed audio can be placed anywhere on campus. Probable locations include within academic and residential complexes (in study or other public areas) and in any other areas where students may wish to "stop off" for some remote retrieval of audio information (such as in the student union). Some clustering of stations makes maintenance easier and may shorten wiring runs.

all other aspects: See Facility Data Sheet B-1.

C4

GROUP VIEWING/LISTENING AREA

description: Small, medium and large groups may desire access to video or audio-video information. All that is required is a television receiver, a dial or channel selector, and a speaker be installed in a small group area (such as that discussed on Sheet B-4), or any other meeting space.

size: See B-4 for comments on the small-group installation for 6 people. Size of other installations may vary, but the comments on optimum viewing area apply to televised images as well as other audio-video images. Usual design parameters for televised images are (see diagram B-4):

- minimum viewing distance: 4 times the diagonal width of screen
- maximum viewing distance: 12 times the diagonal width of screen
- maximum viewing angle: 45 degrees

locations: Rooms may be placed anywhere. Small-group rooms dedicated to this use should be placed where they can be visually supervised and scheduled.

all other aspects: If a small-group room, see B-4. If a large-group room, note considerations on Sheet B-5.

description: The audio laboratory usually includes,

1. A number of STUDENT STATIONS, where the student can listen, speak, hear himself speak, compare his voice with a master, and communicate with an instructor or monitor.
2. A number of PROGRAM SOURCES, whether mounted at the student station or in the instructor's console. These are usually audio tape decks.
3. An INSTRUCTOR'S CONSOLE, which may allow the instructor to select different programs for each student, to monitor, record, and intercommunicate with students.
4. A DISTRIBUTION NETWORK which may consist of station-to-console wiring, or the installation of one or more "audio loops" around the perimeter (or in the ceiling) of the room to allow for wireless communication.

In general, the audio laboratory can be likened to a limited dial-access system where the instructor generally controls the dial. Universities may use these for language, speech, drama, dictation and other speech-oriented skills.

physical form: The audio laboratory consists on one or more rooms, fully acoustically isolated from outside interference. If the audio loop approach is used, physical division will decrease the possibilities of cross-talk. The control console may be placed in the same area with the student stations; but acoustical isolation will give the instructor some flexibility (in receiving visitors, making telephone calls, etc.).

space required: 20 square feet/station is the figure most often used in the design of audio laboratories. 60-80 square feet should be allowed for the instructor's station (or room).

lighting: Even illumination of standard levels is acceptable.

acoustics: While the use of headphones cuts down loud noise, the speaking of users can be annoying. Carpeting is suggested; acoustical treatment of dividers between student stations and ceilings is required.

mechanical: No special requirements.

C-5 (continued)

electrical: In wireless installations, audio loops can be placed on perimeter walls, or laid on suspended ceiling frameworks. In wired situations, cable raceways from console to station are required.

furnishings and equipment: Student stations, with or without program sources, but with visual dividers (at least to eye-level) to adjacent stations; instructor's console; tackboard; coat hooks.

general note: Combination of audio laboratory into lecture-laboratory with appropriate media display surfaces should be considered. (See Design Study MG-3 in "Educational Facilities With New Media"*).

*Green, Alan, et. al., Educational Facilities with New Media, Department of Audiovisual Instruction, National Education Association, Washington, D. C., 1966.

description: The video laboratory is essentially a collection of equipment: a television camera (hand-held, mounted on a table-top for still graphics, mounted on a movable dolly, or permanently mounted to survey a particular scene), a monitor or collection of monitors for displaying the camera image, and most likely a video tape recorder to record and playback the action. The equipment complement may be fully self-sufficient, or it may be wired into the campus TV distribution system for remote origination or display. Finally, all the components may be in one area, or they may not.

physical form: Because of the inherent flexibility of using television in laboratory experiences, several alternatives are possible:

1. Action may be recorded remotely and transmitted to a group viewing area (C-4 or B-6). The only facilities implications are a camera mounting in the remote area, and a cable hook-up (part of the university's system) between origination and display points.
2. Action may be recorded by a movable camera in an area adjacent to the area under observation. The viewing group may be accommodated in the same area or remote from the scene. A one-way viewing panel between the camera area and the area of observation is required in this case. At least 25 square feet should be provided for camera and operator.
3. Any classroom may be outfitted with an internal CCTV system for magnification, photographing group behavior or the speaker, with record and playback in the same area.

locations: A "video laboratory" utilizing an internal CCTV system can be erected anywhere on campus; laboratories using remote origination or display must be provided with cabling between points (theoretically, any area on the university's TV cable network, if one exists, can be part of a video laboratory).

lighting: While it will be uneconomical (and possibly undesirable) to duplicate television studio lighting conditions in areas under TV observation and recording, good lighting (80-100fc) will add much to the video record.

acoustics, mechanical: No special consideration unless lighting produces large heat loads.

electrical: See DISTRIBUTION.

the production/support center

The heart of the distributed audio-video resources system is the origination and production center where these materials are made and set up for campus distribution. The production/support center not only produces and distributes materials over radio and television, but also assists in,

- o materials production, conversion and storage for the dial-access system
- o general audio and audio-video resources production for the faculty, staff and administration
- o backing up the local production centers (B-10)
- o encouraging faculty uses of learning resources
- o overall administration and coordination of the university's resource systems.

The State University of New York has provided for some form of production facilities on each of its campuses, and is now engaged in planning, designing or building some 14 new major production centers as part of the communications/lecture hall center approach. This report will not attempt to duplicate the research materials developed for the planning of those centers.

the dial-access component

The only component not considered in these production/support areas as planned

is ready-storage area for dial-access systems. Materials must be pre-mounted on audio tape recorders, video tape decks, and possibly film chains; this equipment must then be wired into a special-purpose computer and switching matrix for matching requests with program sources. Facilities implications are presented on Sheet C-7, and from this it is obvious that the dial-access areas should relate strongly to the areas where the media are produced, duplicated and stored.

Data Sheet C-8 presents production/support needs only in broadbrush fashion, with particular emphasis on the needs of dial-access systems.

READY-STORED AUDIO-VIDEO RESOURCES AREA

C7

description: An area where random-access program sources (audio, or audio and video) and the necessary switching and control equipment are housed and serviced.

size and configuration: There are so many variables that it is almost impossible to accurately size this space until more is known about the specific program. Equipment modules will more than likely be determining factors, and will include,

1. AUDIO PROGRAM SOURCES, consisting of 24" x 24" x 76" (or roughly equivalent) cabinets, each with a specific number of audio tape decks. The number of program sources in each cabinet will depend on the number of tracks used on each tape, and the number of programs per track. These sources can usually be added one at a time, or a cabinet at a time.
2. VIDEO PROGRAM SOURCES, consisting of cabinets of the same size which contain roughly 4 video tape recorders.
3. PROGRAM AMPLIFIERS, one cabinet (equal in size to the above) must be considered for "x" additional program sources (or program amplification may be built into the sources themselves).
4. CROSSBAR CONTROL AND SWITCHING RACKS, added in modular packages as "x" new student lines are added.
5. COMPUTER CABINETS (note the addition requirement on the system shown on the next page).
6. DISTRIBUTION FRAME, one required for "x" student sources.
7. POWER SUPPLY.
8. SLIDE AND FILM CHAINS for converting material for TV distribution. Each chain generally requires about 100 additional square feet in the room.

The schematic of one such installation shown on the next page indicates that about 625 square feet is needed for the 480 student lines and 192 program sources (audio-video) envisioned by one manufacturer. This diagram includes no area for a technician's desk or any film or slide chains.

The reservation of an area of approximately 1,000 square feet (with additional back-up area in the form of storerooms, an adjacent classroom, etc.) should probably be considered for a collegiate installation. (Spread into adjacent areas does not necessitate removing walls).

C-7 (continued)

In addition, a technical area of 100 or more square feet should be considered integral with or directly adjacent to the main equipment area.

location: Should be as physically centralized on campus as possible to minimize wiring runs. Convenient relationships to television support areas for the campus in general will economize on technical support and maintenance.

access: Access to equipment areas should be limited to qualified technicians.

physical considerations: If it is possible to locate the dial-access equipment in the same vicinity as other technical production areas (studios, engineering, storage, etc.), the possibility of demountable partitioning and the use of modular building bays should be carefully considered. This approach will allow expansion and contraction of the various parts of the technical center as required.

lighting: High levels of overall illumination (50-60fc would seem sufficient) should be provided in equipment areas.

acoustics: Abnormally high noise levels will not be generated.

mechanical: Area should be air conditioned; direct venting of units not required.

electrical: 110v power service probably sufficient (check manufacturer).

communications: Telephone at technician's desk. In addition to being a regular phone extension, the headset will be tied into the dial-access system to receive requests and calls for assistance.

furnishings and equipment: Racks and program modules as required; technician's desk and work bench should be provided.

NOTES

1. Unit 1 - Crossbar Control Rack - One req'd per system.
2. Unit 2 - Crossbar switching racks - One req'd for each 80 student lines.
3. Unit 3 - Power Supply - One req'd per system.
4. Unit 4 - Computer Cabinets - Four req'd for first 512 student lines; two additional cabinets req'd for next 512 lines.
5. Unit 5 - Distribution Frame - One req'd for each 240 student lines.
6. Unit 6 - Tape Deck Cabinets - One req'd for each four tape decks; tape decks may be 1-, 2-, or 4-track.
7. Unit 7 - Program Amplifier Cabinets - One req'd for each 32 program sources.

8. Maximum Weights (each cabinet)

1 - 450 lbs.	5 - 500 lbs.
2 - 1,500 "	6 - 400 "
3 - 1,000 "	7 - 400 "
4 - 800 "	

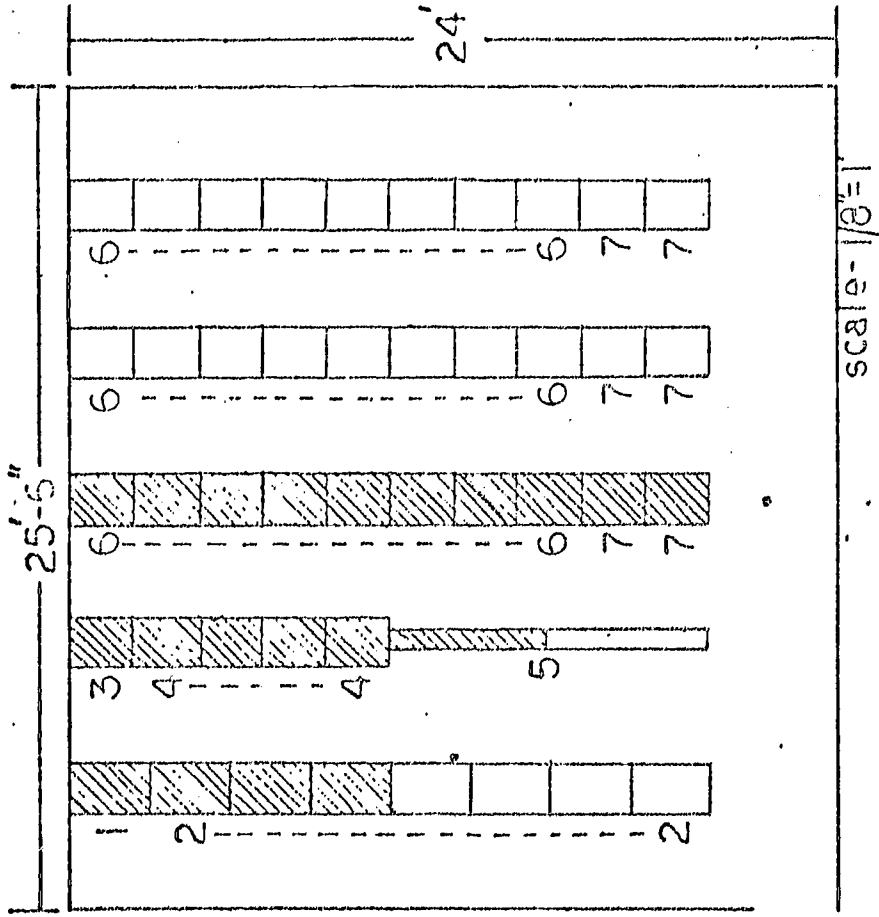

9. Minimum 10' ceiling height req'd for units 1 and 2.
10. Equipped for 240 student lines, 64 program sources; Expansion shown to 480 student lines, 192 program sources.

Typical Dial-Access Learning System
Equipment Layout

description: The university committed to wide-spread use of audio-video resources, both distributed and non-distributed, must provide a substantial production/support center. Centers similar to those being planned and built as part of the communications centers on many SUNY campuses should be adequate, with the possible addition of dial-access capability (C-7).

The production/support center will undoubtedly include a complement of television studios and control rooms, kinescope and filmchain areas, television control and distribution center, graphic arts studios, film studios, animation and editing areas, darkrooms, equipment engineering and storage, prop workshop and storage, an audio-video materials store, previewing areas and the requisite staff and administrative spaces. Full programming data for all of these spaces has been prepared for SUNY.

considerations for dial-access: In addition to the comments made on Sheet C-7, the production/support area should recognize dial-access by,

1. Locating the dial-access ready-stored materials area (C-7) as part of the production/support center, perhaps separating the two by demountable partitioning for year-to-year flexibility.
2. Provide these component areas in the vicinity of the dial-access area; technicians work area (with a possible glass vision panel to the dial-access area), equipment maintenance and repair area, one conference/preview area (for previewing dial-access materials), and a small audio-video storage area.
3. Consider the possibility of "sharing" film and slide chains for both dial-access and broadcast television uses. This has no direct facility implications, except that any film chains concerned should be wired back to the main television control and distribution area.

distribution: In addition to regular television distribution (for which SUNY data already exist), the dial-access system requires a pair of wires (one manufacturer requires 600-ohm resistance) from each remote station to the ready-stored wiring conduits and trays where possible.

5

FACSIMILE
RESOURCE SYSTEM

As long as there are information stores, information will be collected and retrieved in facsimile form -- either full-size (as in the case with the book) or in some microform.

The possibility of storing "all" information within a computer's random access memory has always been an attractive one. The great bulk of data, however, does not require this kind of sophistication; and, of course, there will always be materials which cannot be efficiently encoded into computer media. The problems of special symbols, page layouts, type faces, etc. will always be of primary importance to some segments of the university's collection.

The problems of full-size facsimile storage can be seen in libraries all over the world; the material is bulky, takes up great chunks of space, and retrieval is slow. The increasing use of microforms for facsimile storage, however, begins to chip away at some of these problems. Advantages include,

1. Reduction in bulk is most important. Using NCR's new HR-fiche, for example, a library of 60,000 standard volumes can be stored in one file drawer.
2. Reduction in bulk decreases retrieval time (the library is not so physically large and widespread).

3. Reduction in bulk allows many collections (perhaps duplicating each other) on campus, shortening access time.
4. The material is portable and can be easily mailed, or even sent through a pneumatic tube.
5. With the placing of many images on a single fiche (3,200 on the 4" x 6" fiche used by NCR's HR-fiche), browsing of related items is possible.
6. The material is preserved intact with no deterioration.
7. Copying and duplicating processes are becoming more sophisticated and less expensive.
8. Display and reading equipment is improving in quality.
9. Paper hardcopy is available when needed.

full-size facsimile use patterns

Libraries are already expert in the management of full-size facsimile resources (i.e. books). The trend is toward more hardcopy duplication of full-size items, thus allowing the user the benefit of a few crucial pages rather than removing the entire resource from the collection. Facility Data Sheets D-1 and D-2 briefly explore hardcopy production areas.

components of a microform system

It is important to realize that any significant use of microform on the campus requires the consideration of four main components:

- o A store of microform, from which materials can be retrieved and checked out.
- o A number of presentation devices which allow the user to inspect and use the microform.
- o An index, or computer access to index, which allows user search for further bibliographic information and other sources of materials.
- o A back-up unit which produces, duplicates and otherwise administers the microform operation.

The real basis for these components is not the amount of square feet allocated for them; rather it is the existence of a clear-cut university policy with respect to microform. The policy must answer these questions:

- o What TYPES of microforms will be used? Microfilm? Microfiche? Aperture cards? High-reduction fiche? Each will require differing amounts of space, production and reading equipment. The university probably cannot afford to limit itself to one form, but using all forms will undoubtedly be uneconomical.

- How will microforms be PROCURED? Will they be produced at the university, or will the great majority be bought from commercial suppliers. Early efforts will probably (of necessity) emphasize the former. As new suppliers join in, the university can turn its task (and resources) from procurement to duplication.
- How will microforms be STORED? One single center? A number of centers around campus, each duplicating the other (not as impossible as it sounds with microforms)? A number of discipline-oriented centers on campus? If the "satellite" approach is taken, there may be several storage-checkout-presentation areas on campus, each backed up by a central production and duplication center.
- What will be the need for DUPLICATION? Will each area have enough copies to avoid duplication? Will the duplication center supply duplicates on demand? Will all the facets of the microform system be linked with pneumatic tubes so that duplicate copies can be swapped at will?

Each of these decisions will affect the relative amounts and locations of space for storage, presentation and production.

microform use patterns

No matter how the questions are answered, the user will probably approach a storage center (D-5, either a central store or a satellite), utilize adjacent computer terminals for index work (A-6), manually retrieve the microform from the storage area and take it to a presentation area (D-3) for inspection. When he is finished, he may return the microform to the checkout area (D-4) for refiling, or he may choose to take it out of the center - reading it later in a microform presentation area (D-3) in his residential or academic area.

hardcopy capability

The most common type of facsimile presentation today is the paper hardcopy made electrostatically (or by other dry-copy techniques) from paper originals. In spite of increased attempts at diminishing the bulk of the university's information store through the use of microforms, there will always remain a need for paper hardcopy production.

It is also possible to produce paper hardcopy from microformed materials. Some of the desk-top reader/printers presented on Sheet D-3 may carry hardcopy capability. As the use of microforms becomes more significant, however, thought should be given to a larger, hardcopy production unit that can provide the quantity demanded by many users.

Facility implications for both types of machines are presented on Facility Data Sheet D-1; D-2 presents implications for remote telecopy devices that transmitted paper hardcopy from place to place.

microform presentation

The use of microform presumes some sort of display device which projects the contents of the microform on a self-contained rear screen for the user's inspection. These devices are becoming quite sophisticated, producing high image

quality, and at reasonable prices. Some project the microform a frame at a time; others allow multiple-frame presentations, and enlarging capabilities. Some of the devices can produce paper hardcopy of any selected frame.

Since the great majority of microform readers produce similar facility implications, these are consolidated on Sheet D-3.

HARDCOPY PRODUCTION AREA

D 1

description: An area containing equipment for making hard facsimile copies from original materials (on paper, or possibly microform). The area will contain one large machine for quantity production of copies; smaller, desk-type copiers will undoubtedly be located in local production areas (B-10), in microform presentation areas (D-3) and in other office spaces around campus.

size and configuration: The largest copying equipment (the Xerox 2400 or equivalent) requires about 120 square feet (10' x 12') to accommodate the machine and service clearances. An additional 40' ² for waiting space should be considered.

location and access: Hardcopy request/presentation areas should be located as near the primary collection of paper and microform resources as possible. Coin-operated, unattended, smaller copying machines may be located elsewhere in the resources areas for 1- and 2-page and for off-hours hours.

Access to main circulation routes by a counter and a full-length door.

lighting: Standard considerations.

acoustics: Acoustical surfacing on ceiling and one or two walls will cut down machine noises; acoustical enclosure from circulation area not required if this is done.

mechanical: Direct exhausting of machine area.

electrical: Large machines will probably require 220v service.

furnishings and equipment: Copying machine; small table for collating; counter; under-counter storage for incoming, outgoing jobs.

general: Addition of additional copying capability (such as a large microform copier, about the same size as the large drycopying machine) is possible within one room; additional counter area not required.