

DOCUMENT RESUME

ED 037 698

AL 000 960

AUTHOR Wang, William S-Y.
TITLE Conjoining and Deletion in Mandarin Syntax.
INSTITUTION California Univ., Berkeley.
SPONS AGENCY National Science Foundation, Washington, D.C.
REPORT NO POLA-2-3-1
PUB DATE 64
NOTE 25p.; Paper presented at the Summer Meeting of the Linguistic Society of America, Bloomington, Indiana, July 1964

EDRS PRICE EDRS Price MF-\$0.25 HC-\$1.35
DESCRIPTORS *Deep Structure, *Linguistic Theory, *Mandarin Chinese, Phrase Structure, Semantics, Sentence Structure, *Surface Structure, Syntax, *Transformation Generative Grammar, Verbs

ABSTRACT

This is an investigation of deletion procedures from surface structure to deep structure in Mandarin Chinese. The author explains that the deep structure of a sentence provides complete information on the semantic and syntactic constituency of the sentence, while surface structure contains information about the phonological interpretation and phonetic actualization. The surface and deep structures are related by a sequence of syntactic rules; the author maintains that some constituencies have to be deleted from the deep structure in order to derive the surface structure in Mandarin. These deletions are the subject of the paper, and are also relevant to the general theory of language development. Here, a sector of Mandarin Chinese grammar is examined in order to determine what kinds of relationships exist between the deep and surface structures and how these relationships relate to language universals. The discussion is substantiated with extensive examples. (FB)

U.S. DEPARTMENT OF HEALTH, EDUCATION & WELFARE
OFFICE OF EDUCATION

THIS DOCUMENT HAS BEEN REPRODUCED EXACTLY AS RECEIVED FROM THE
PERSON OR ORGANIZATION ORIGINATING IT. POINTS OF VIEW OR OPINIONS
STATED DO NOT NECESSARILY REPRESENT OFFICIAL OFFICE OF EDUCATION
POSITION OR POLICY.

ED037698

Conjoining and Deletion in Mandarin Syntax*

William S-Y. Wang

University of California, Berkeley

AL 000 960

*The preparation of this paper was supported in part by National Science
Foundation Grant GS1430.

Recent research into the theory of grammar indicates the importance of distinguishing between the deep structure and the surface structure of a language.^{1,2} At the deep-structure level, we may represent a sentence in the form of a labelled tree diagram called a deep P-marker (abbreviated P-d).³ The P-d contains rather complete information on the semantic and syntactic constituency of the sentence; it serves as a basis for the application of the rules for semantic interpretation of the sentence. At the surface-structure level, the surface P-marker (P-s) may differ from its associated P-d in a variety of ways. It is the P-s that serves as the basis for the application of the rules for phonological interpretation; this ultimately yields the phonetic actualization of the sentence.

A P-s is related to its P-d by a sequence of syntactic rules. If the sentence under analysis is complex, it is likely that some constituents will be deleted from the P-d in deriving the P-s. The nature of these deletions is therefore of importance for the general theory of language. In particular, we may ask whether there are aspects of these deletions which are independent of individual languages and hence characteristic of some universal relation between certain types of deep and surface P-markers.⁴

With this question in mind, I shall examine a small sector of Mandarin grammar: certain types of P-d's which involve unlimited conjoining, and some of the relations between these P-d's and their corresponding P-s's.⁵

All P-d's are generated by phrase-structure rules of the base component of the grammar. We provide for an unlimited sequence of conjoined sentences by the rule schema shown in Figure 1. (c_{jv} stands for 'conjunction for verb phrases', c_{jn} for 'conjunction for noun phrases'. The superscript n means that either after c_{jv} or before c_{jn}, S may be repeated an arbitrary number of times.)

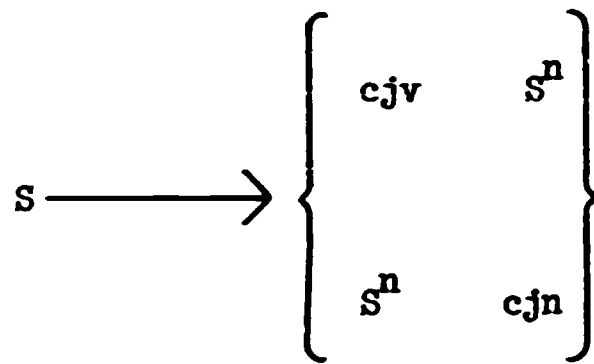

Figure 1.

Rule schema for conjoining.

For some types of conjoining in Mandarin, *n* must be two. That is, only two sentences may be conjoined at a time, and these two sentences must be paired in a particular way. In the A-not-A type of disjunctive question,⁶ for example, the P-s contains an affirmative verb phrase followed by its negative counterpart. A sentence like

Nǐ yào bú yào mǎi shū? 'Do you want to buy books?'

can be analyzed as conjoined from two declarative sentences:

Nǐ yào mǎi shū 'You want to buy books'

and

Nǐ bú yào mǎi shū 'You don't want to buy books'.

Another place where the conjoining must be of pairs of sentences may perhaps be found in the so-called concessive clause, e.g.

Tā shū shì mǎi, kěshì bù mǎi bǐ.

This may be translated roughly as 'Books he will buy all right, but he won't buy any pencils'. My hypothesis is that the clause Tā shū shì mǎi is conjoined from the declarative Tā mǎi shū 'He buys books' and the confirmative shì-de construction Tā shì mǎi shū de 'It is true that he buys books' (roughly). The exact analysis remains to be worked out.

There are many types of conjoining, however, which are not restricted as to the number of constituent sentences. The two cases just mentioned are probably rather special and need to be studied in greater detail. In Mandarin, as in English, each basic sentence may be regarded as consisting of two parts--a noun phrase (NP) followed by a verb phrase (VP). Two major types of conjoining are therefore possible. If the VP's in the constituent sentences match each other (i.e. are the same), we may delete all of these but the last one. The NP's, which were originally separated by VP's, can now be grouped together. I refer to such cases as NP conjunction.

On the other hand, there may be a match among the NP's of the constituent sentences, and we have VP conjunction. Here we delete all of the matched NP's but the first one. In the case of NP conjunction, the cjn is transported to a position directly preceding the preserved VP. The cjn-class of morphemes includes chuán and dōu,⁷ as exemplified in

Zhāng xiānshēng, Lǐ xiānshēng, Chén xiānshēng chuán lái

'Mr. Chang, Mr. Li, and Mr. Chen are all coming'

or

Zhuōzi, yǐzi, chuáng dōu hěn guì 'Tables, chairs, and beds are all very expensive'.

In the case of VP conjunction, the positioning of the cjv is rather complicated. Unlike the cjn, the cjv is distributed among each of the VP's, as illustrated by the cjv's yòu and yě in the following sentences:

Tā yòu huì dǎ zì yòu huì huà huà.

Tā yě huì dǎ zì yě huì huà huà.

Both of these sentences, though differing slightly in emphasis and connotation, mean 'He can type and paint'.

The cjv may also have no phonetic shape, so that we have simply

Tā huì dǎ zì huì huà huà.

In this paper, I shall not be concerned further with the problem of the positioning of the conjunctions; my focus will be rather on the constituent structure of the various types of conjoined sentences. Of central interest will be the set of principles which determines the constituent structure of the P-s's, as these are derived from the P-d's. It is reasonable to expect that these principles will be pertinent to the process of conjoining in many other languages.

Figure 2 is an example of NP conjunction in Mandarin, i.e. two sentences followed by cjn. (For easy reference, I have put subscripts under the two S's, i.e. S_1 and S_2 ; these subscripts have no formal significance. The matching VP's of S_1 and S_2 are marked by circling. By a match, I mean that all corresponding nodes dominated by the two VP's are identical.)

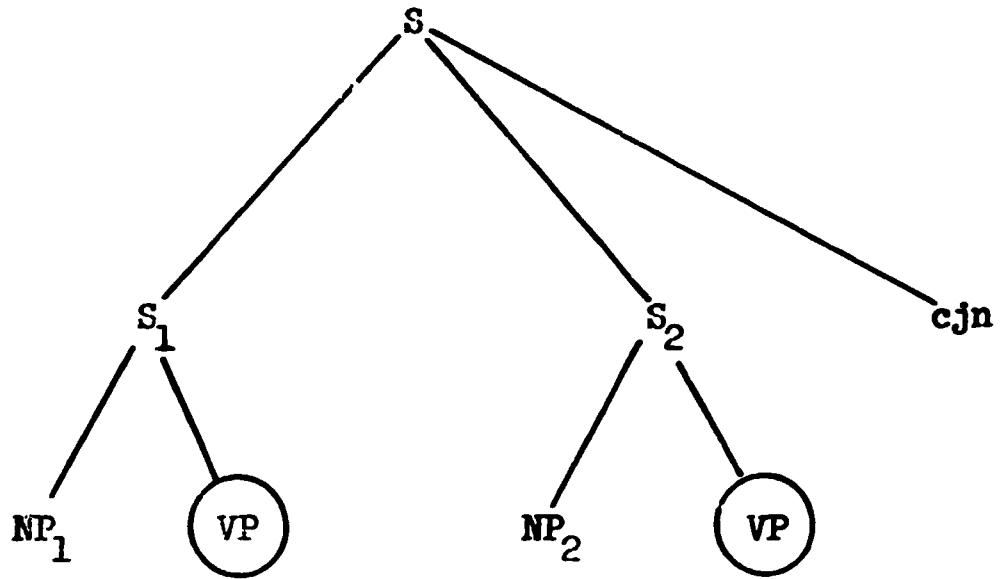

Figure 2-A.

P-d with VP match.

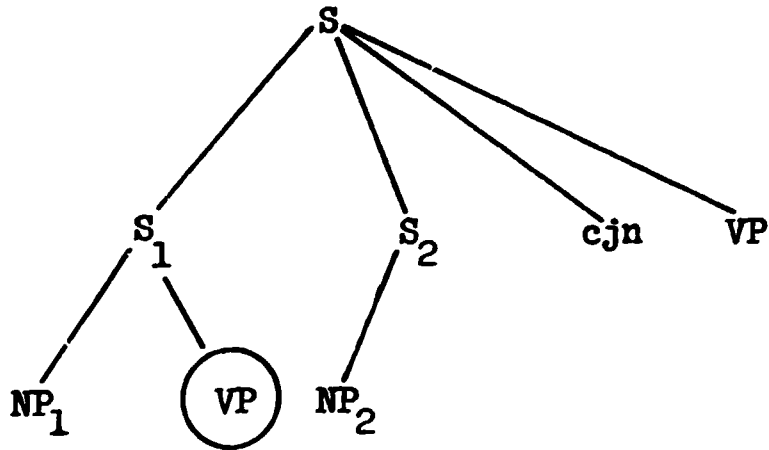

Figure 2-B.

Output of Step 1 (reattachment).

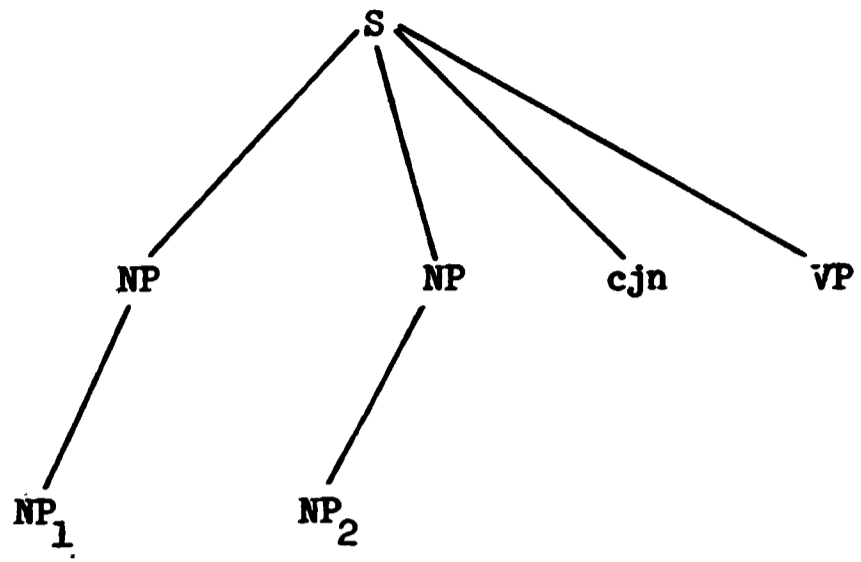

Figure 2-C.

Deletion and relabeling.

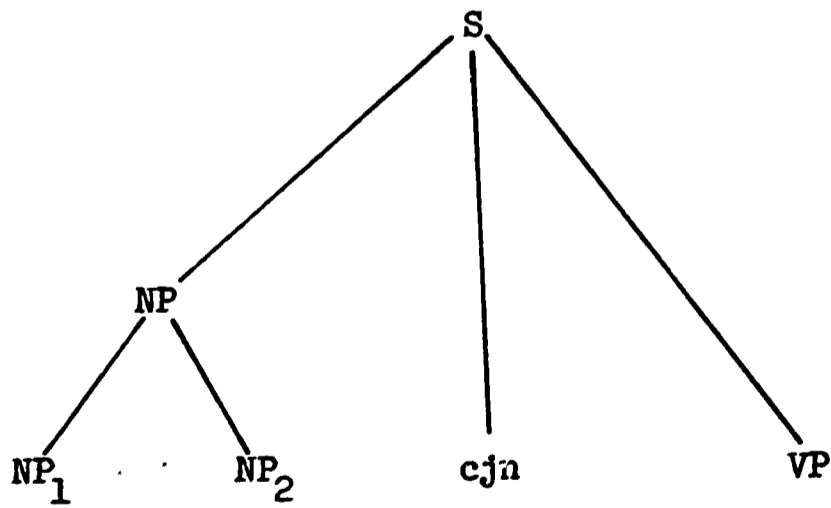

Figure 2-D.

Grouping.

To transform the P-d of Figure 2-A to the P-s of Figure 2-D, three steps are necessary. In the first step, 'reattachment', we take the matched constituent closest to the conjunction and break it off from the node which dominates it. We move this constituent in the direction of the conjunction and attach it to the next higher node in the P-marker. If it is thereby attached to the same node as the conjunction, it is permuted (i.e. changes places) with the latter. The result of this step is seen in the P-marker of Figure 2-B. Note that the reattached VP is now unmarked.

The next step has two parts. First, all of the marked constituents must be deleted. In Figure 2, this applies only to the VP in S_1 , since the VP in S_2 has already been moved away and is no longer marked. The deletion therefore applies to one less than the number of constituents which are matched in the P-d.

The nodes S_1 and S_2 , which originally dominated both NP's and VP's, now dominate only one NP each. In the usual interpretation of P-markers, this means that now NP_1 is an S_1 and NP_2 is an S_2 ; in the present context, this is clearly unacceptable. The principle involved is a simple one. Given a structure α dominating β and γ , where neither β nor γ is optional, it must be the case that neither β nor γ is an α . In instances where either β or γ is deleted or moved away, it seems reasonable to relabel the dominating node with the same symbol as the only node that it directly dominates. The result of the deletion and relabeling of Figure 2-B is shown in Figure 2-C. Here we see that the nodes which were initially labeled S are now labeled NP.

The last step in deriving the P-s is grouping. Essentially, the principle involved is this. A P-marker in which a node α dominates n

nodes labeled β , and in which each β node further dominates a node labeled β , may be grouped in such a way that α dominates only one β node, which in turn dominates n β nodes. Note that the P-marker in Figure 2-C satisfies such a description, in that S dominates two NP's, each of which in turn dominates another NP. The result of the grouping is shown in Figure 2-D, which, I believe, is the correct P-s. The bottom string of the P-d of Figure 2-A may, for example, be something like

Zhuōzi hěn guì--yǐzi hěn guì--dōu 'Tables very expensive--
chairs very expensive--dōu'

The bottom string of the corresponding P-s would then be

Zhuōzi yǐzi dōu hěn guì 'Tables and chairs are all
very expensive'

Figure 3 is an example of VP conjunction. The same principles are involved in relating this set of P-markers; the same steps must be taken: match, reattach, delete, relabel, and group. The only difference is that since the conjunction is now on the other side, the NP reattachment is in the opposite direction from the VP reattachment.

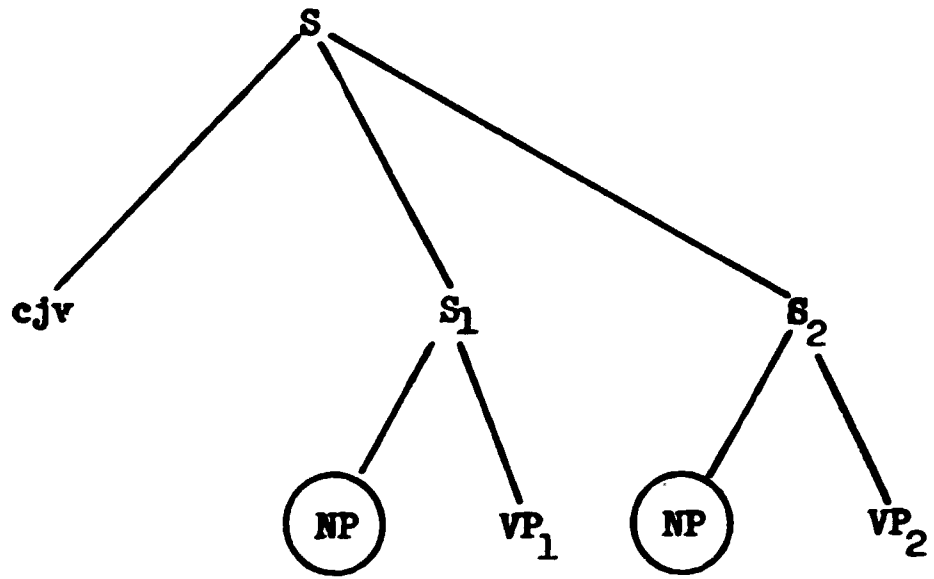

Figure 3-A.

P-d with NP match.

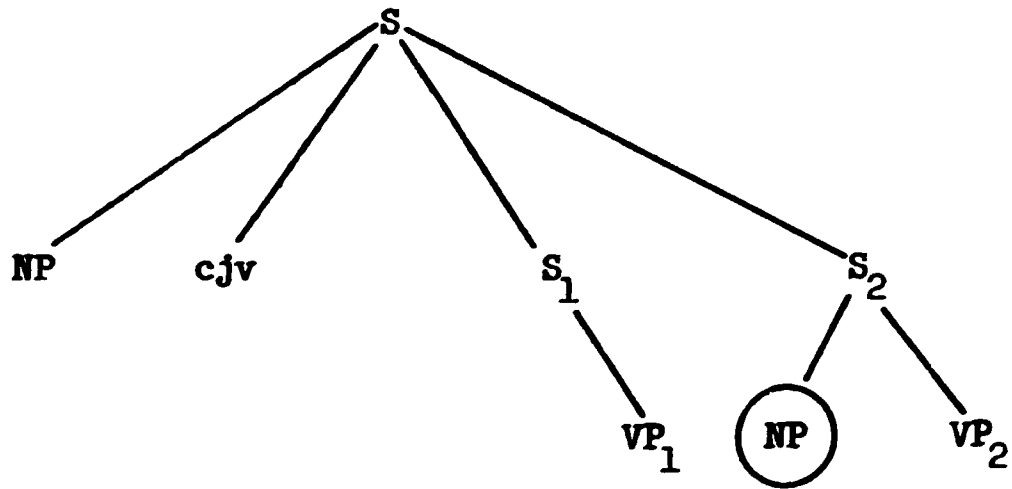

Figure 3-B.

Output of Step 1 (reattachment).

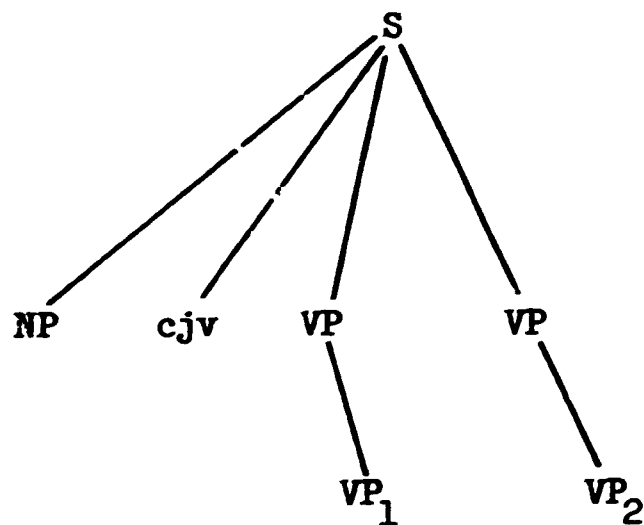

Figure 3-C.

Deletion and relabeling.

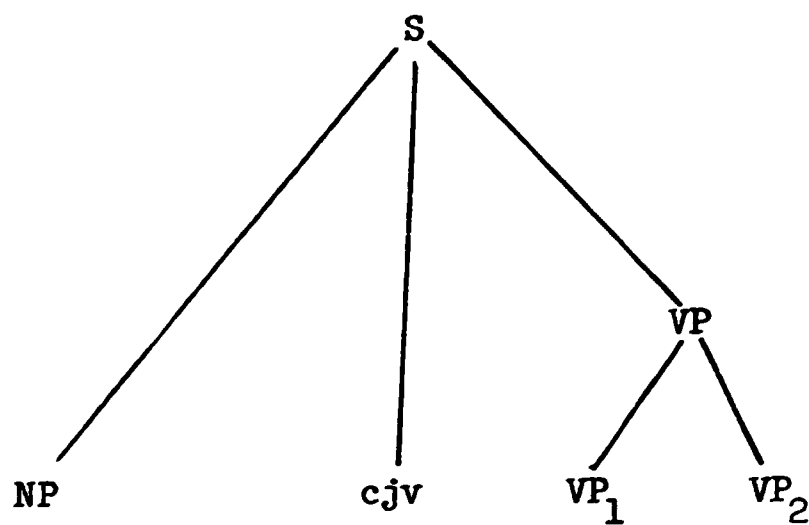

Figure 3-D.

Grouping.

In Figure 4, I present examples of further deletions which take place in successive steps when a match is established among elements across conjoined constituents.

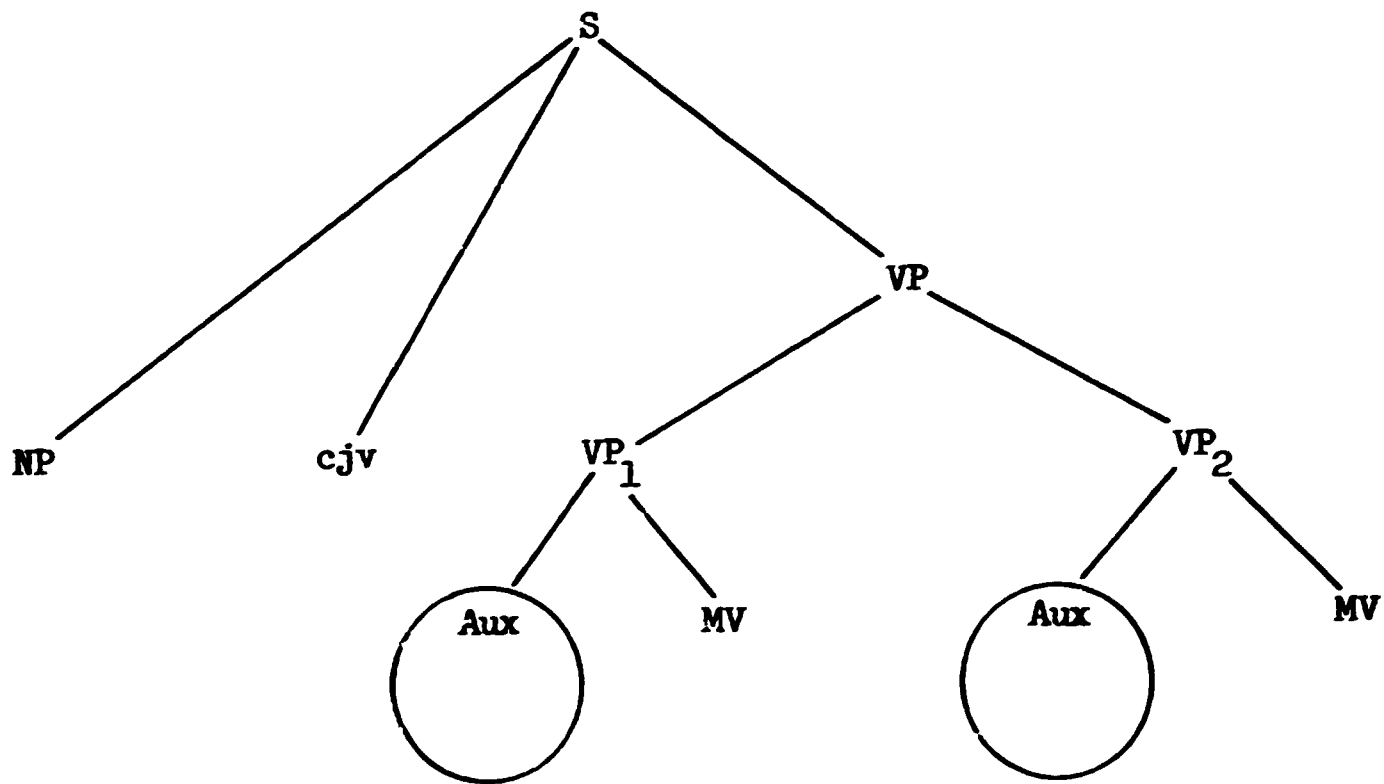

Figure 4-A.

Conjoined VP with Aux match.

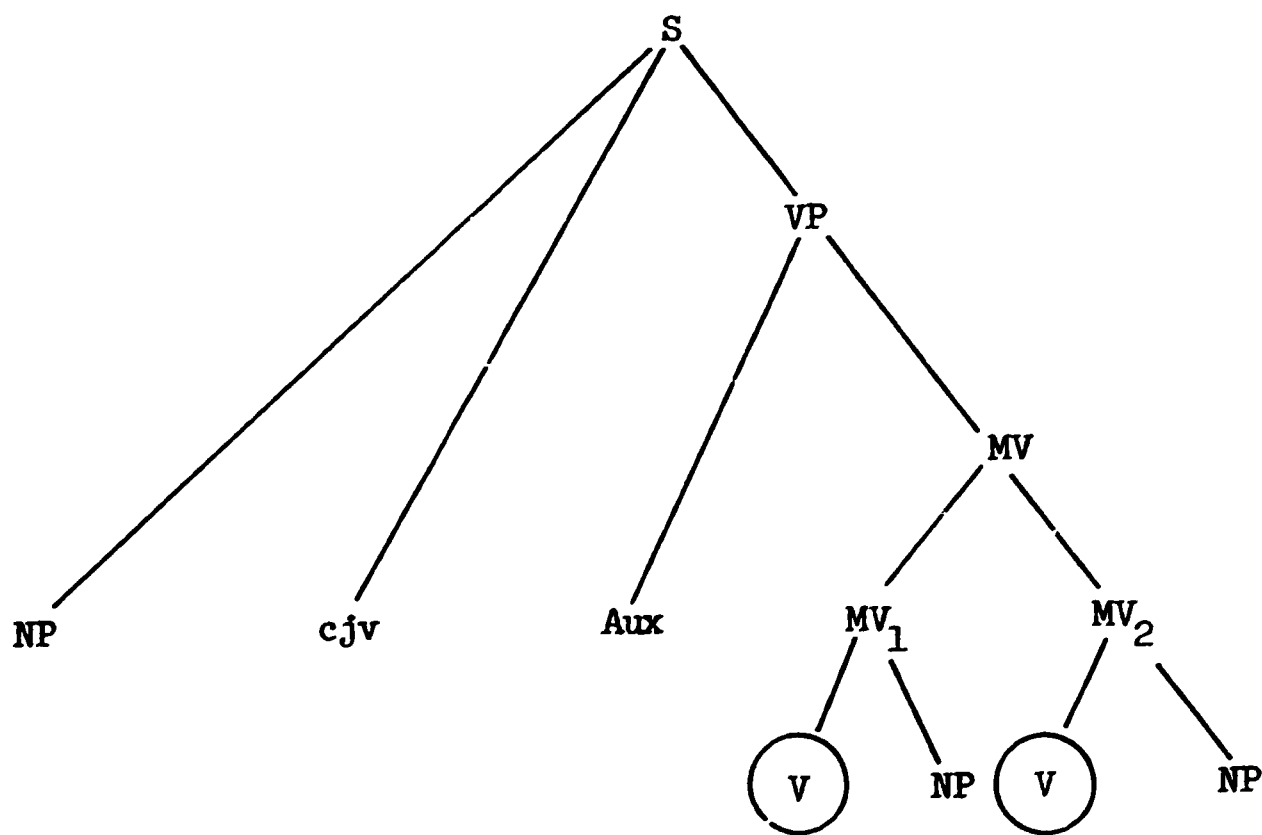

Figure 4-B.

Conjoined VP with V match.

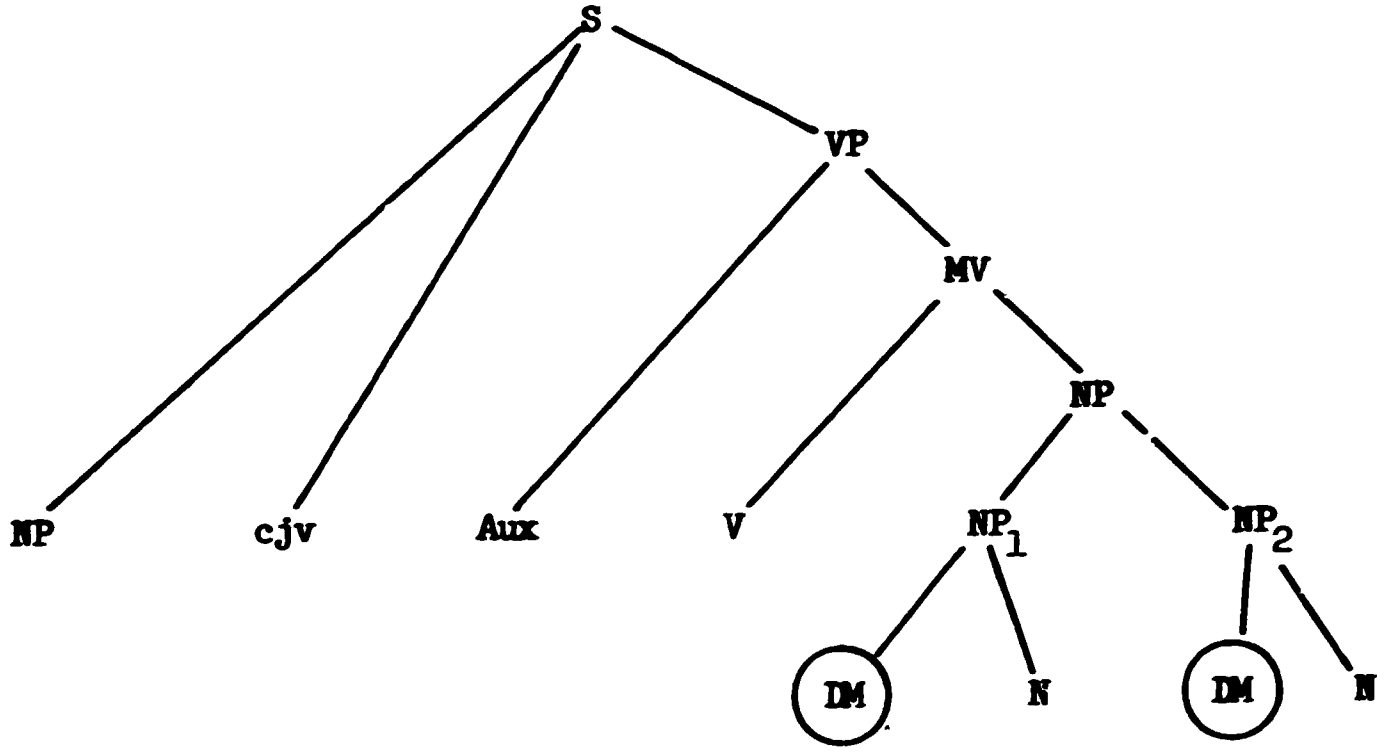

Figure 4-C.

Conjoined VP with D-M match.

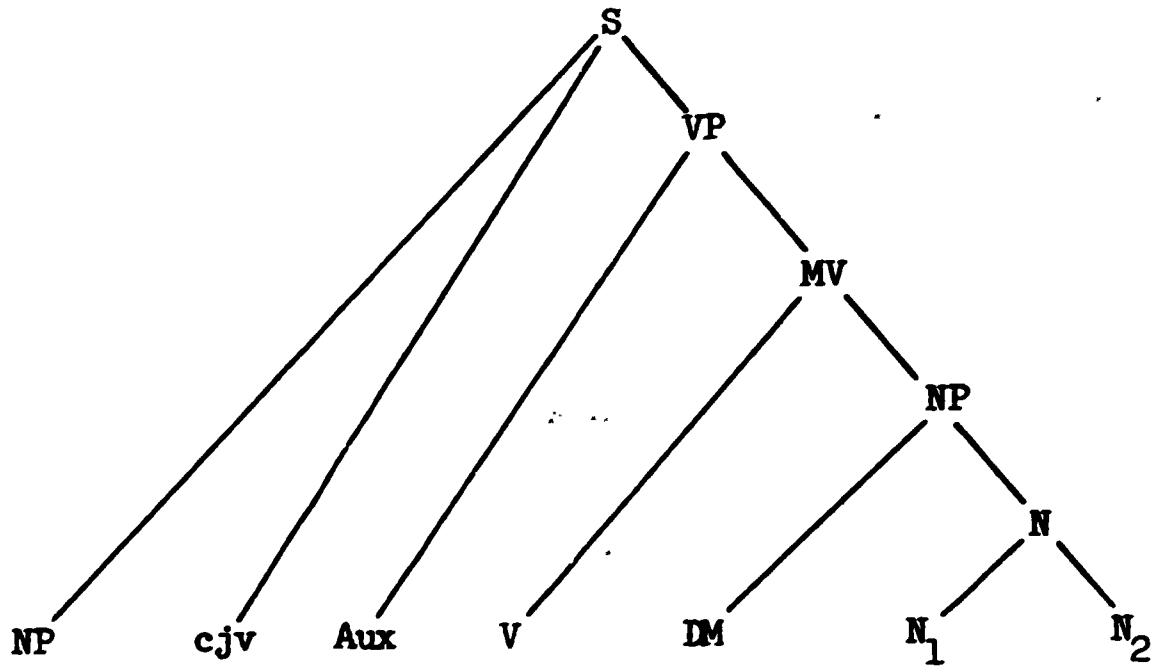

Figure 4-D.

Surface P-marker.

Figure 4-A shows a P-marker that is derived by the steps illustrated in Figure 2. Suppose that each of the conjoined VP's contains, in addition to the main verb (MV), an auxiliary verb (Aux), and suppose that these Aux's match. Then it is possible to delete all but the first Aux and conjoin the remainders of the VP's in a coordinate construction. The P-marker which results from deleting the second Aux is shown in Figure 4-B. In comparing the two P-markers, it can be seen that the same steps are involved as those illustrated in Figures 2 and 3. The Aux closest to the conjunction is moved in the direction of the conjunction to be reattached to the next higher node, which is in this case VP. The other Aux is then deleted; the remainders of the two VP's are relabeled and grouped.

Similarly, if the verbs match, as shown in Figure 4-B, we derive 4-C. Again, if the DM's match, we can derive 4-D from 4-C (DM stands for determinative and measure, the shù liàng cí of Chinese grammars). At each successive stage, the same principles of deletion are involved, the same elementary steps are applicable. To illustrate these stages, consider the two sentences

Tā yào mǎi yìxiē qiān bǐ 'He wants to buy pencils'

and

Tā yào mǎi yìxiē máo bǐ 'He wants to buy some brushes'

In conjoining these two, we first delete the subject NP from the second sentence, according to the steps illustrated in Figure 3. The resulting string is

Tā yào mǎi yìxiē qiān bǐ yào mǎi yìxiē máo bǐ.

This has the constituent structure indicated in Figure 4-B. Deleting the matched Aux, we get

Tā yào mǎi yixie qiān bǐ mǎi yixie máo bǐ,

with the structure indicated in Figure 4-C. Finally, deleting the matched DM, we get

Tā yào mǎi yixie qiān bǐ máo bǐ,

with the P-s represented in Figure 4-D. At each stage, the deletion may be blocked if there is no further match. When there is a match, however, the deletion appears to be obligatory in normal speech. The English sentences corresponding to the P-markers in Figure 4 are, roughly, as follows:

- 4-A. He wants to buy some pencils and wants to buy some brushes.
- 4-B. He wants to buy some pencils and to buy some brushes.
- 4-C. He wants to buy some pencils and some brushes.
- 4-D. He wants to buy some pencils and brushes.

So far, I have given examples of several different types of conjunction; I have observed that the same syntactic principles can be used to account for them. There are, however, several related coordinate constructions which do not conform to these principles of conjoining and deleting. I will discuss briefly two types of exceptions, both of which involve exactly two S's in the P-d.

First, there is the situation where there is an obvious match, but deletion of the matched constituent is not permissible. This occurs in a type of disjunctive question where the VP's are matched, as in

Nǐ gāo tā gāo.

The two constituent sentences are clearly Nǐ gāo 'you are tall' and tā gāo 'he is tall'; the derived question means 'Who is taller, you or he?' In such a construction, deleting either VP would yield an ungrammatical sequence, e.g. *Nǐ gāo tā or *Nǐ tā gāo. If the P-d of Nǐ gāo tā gāo

were like the one exemplified in Figure 2, we would, of course, get

*Nǐ tā gāo.

A second type of exception has to do with multiple possibilities of deletion. Thus, in the A-not-A question form, the deletion may take place from either the affirmative or the negative VP. From two sentences like

Tā yào mǎi shū 'He wants to buy books'

and

Tā bú yào mǎi shū 'He doesn't want to buy books'

we can derive a question: 'Does he like to buy books?' But this question can have two forms: either

Tā yào bú yào mǎi shū

or

Tā yào mǎi shū bú yào.

In the speech of the older generation, this dual deletibility was not permissible in the Peking dialect when the sentence contained certain aspect markers. In a pair of sentences like

Tā mǎi le shū 'He has bought books'

and

Tā méi yǒu mǎi shū 'He has not bought books'

a speaker could only delete from the negative, or second, VP, and get Tā mǎi le shū méi yǒu. According to a recent grammar published in Peking, however, this restriction in the grammar seems to be disappearing; the other deletion is also possible, i.e. Tā yǒu méi yǒu mǎi shū.⁸ Here the syntax of the language has undergone a historical change toward a greater parallelism of plain sentences and sentences with aspect markers. In the grammar of the older generation, the deletion transformation for A-not-A

questions has a restriction when it is applied to a P-d that contains aspect markers. In the grammar of the younger generation, however, this restriction is no longer required, making for a simpler syntax. This restriction is also unnecessary for most Mǐn and Yuè dialects of Chinese. Whether these dialects have also undergone a similar process of syntactic simplification can only be answered by examining earlier stages of these dialects to see if this restriction was, indeed, once there.

Footnotes

¹ This paper is based on an oral version presented at the 1964 summer meeting of the Linguistic Society of America. Work on the revision of the paper was supported in part by the National Science Foundation under Grant NSF GS1430. I wish to thank Betty Shefts Chang for assistance in preparing this paper for publication.

² The terms 'deep' and 'surface' as applied to grammatical description were introduced by C. F. Hockett (see his A course in modern linguistics, Chapter 29 [New York, 1958]). A related distinction is that between what Lucien Tesnière called 'l'ordre structural' and 'l'ordre linéaire', which plays a central role in his Éléments de syntaxe structurale (Paris, 1959). The transformational framework upon which the present paper is based was first discussed in A. N. Chomsky's Syntactic structures; a Chinese version of this book, prepared by John H-T. Lu and myself, was published by the Hong Kong University Press in 1966, under the title Bianhuanlǚ yufa lilun. See also Chomsky's Aspects of the theory of syntax (Cambridge, 1965) for a more explicit discussion of deep and surface structure.

³ More precisely, the tree diagrams which represent P-d are unordered, in that no such relation as 'to-the-left-of' is specified for the nodes in the tree. Like mobiles, the nodes may be permuted in any fashion as long as the constituency relations among them are preserved. The tree diagrams which represent P-s, on the other hand, are obviously ordered, in that, to be realized phonetically, the terminal nodes need to be in some fixed order; this order will also induce an order of the nonterminal nodes. For a formal discussion of the tree graph, see L. F. Meyers and W. S-Y. Wang, Tree representations in linguistics, Project on Linguistic Analysis Report No. 3r, pp. 54-111 (Ohio State University Research Foundation, May, 1963).

⁴ For additional discussions on the formal relations between P-d and P-s, see Emmon Bach, On some recurrent types of transformations, Georgetown University Monograph No. 18 on Languages and Linguistics 3-18, and John R. Ross, Gapping and the order of constituents, a paper presented at the Tenth International Congress of Linguists.

⁵ The present paper is part of a continuing effort to uncover the underlying regularities of Chinese grammar. Earlier attempts are reported in my paper on Some syntactic rules for Mandarin, Proceedings of the Ninth International Congress of Linguists 191-202 (Mouton, 1964); Two aspect markers in Mandarin, Language 41.3:457-70 (1965); and Jyufa fenxi de yuanze, Zhongguo yuwen 18.6:6-17, Issue 108 (Taipei; June, 1966).

⁶ Y. R. Chao discusses some general features of disjunctive questions (Mandarin primer 58 f. [1948]). I follow Professor Chao in the use of the term 'A-not-A question'.

⁷ The conjunction dōu discussed here is not to be confused with the dōu in a sentence like Tā zìjǐ dōu bú qù 'He is not even going himself'; the latter dōu is clearly reduced from the discontinuous construction lián ... dōu 'even'. But consider sentences like Zhèxiè rén dōu qù 'These people are all going' or Tā zhèngtiān dōu zài jiā 'He is at home all day'. In such sentences, we have dōu used to quantify nominals, which either are plural (explicitly or implicitly) or cover a continuous stretch of time. It seems appropriate to consider the dōu in these sentences a conjunction, but it is not clear what the exact form of the P-d is. For a more extensive discussion of this problem in Mandarin syntax, see Robert L-W. Cheng, Universe-scope relations and Mandarin noun phrases (to appear in Project

on Linguistic Analysis Reports, Second Series, University of California, Berkeley, Phonology Laboratory). The nature of the problem is such, of course, that parallel forms of it must exist in most languages.

⁸ See Two aspect markers in Mandarin (cited above in fn. 5), especially fn. 12.