

DOCUMENT RESUME

ED 036 118

EF 004 029

AUTHOR BURSTON, O.
TITLE DETERMINATION OF ORIENTATION AND SUNSHADING OF ASIAN
SCHOOLS WITH THE USE OF A HELIODON.
INSTITUTION ASIAN REGIONAL INST. FOR SCHOOL BUILDING RESEARCH,
COLCHEC (CEYLON).
PUB DATE 69
NOTE 6P.; SCHOOL BUILDING DIGEST 5

EDRS PRICE MF-\$0.25 HC-\$0.40
DESCRIPTORS *CLASSROOM ENVIRONMENT, CLIMATE CONTROL, CLIMATIC
FACTORS, CONTROLLED ENVIRONMENT, ENVIRONMENTAL
INFLUENCES, *EQUIPMENT, GEOGRAPHIC LOCATION,
INTERIOR SPACE, LIGHT, *LIGHTING, PHYSICAL DESIGN
NEEDS, RESEARCH, *SCHOOL DESIGN, SITE DEVELOPMENT,
*SOLAR RADIATION, THERMAL ENVIRONMENT

ABSTRACT

DESIGNING AND PLANNING ASIAN SCHOOL BUILDINGS WITH
REGARD TO SUNSHADING AND THE AID OF A HELIODON IS DISCUSSED,
DESCRIBING WHAT IT IS, HOW IT IS USED, WHAT IT IS USED FOR AND HOW TO
CALIBRATE WITH IT. CHARTS, DRAWINGS AND REFERENCE LIST ARE INCLUDED.
(TG)

SCHOOL BUILDING DIGEST 5.

Asian Regional Institute for School Building Research

(sponsored by unesco)

P. O. Box 1368, Colombo, Ceylon.



DETERMINATION OF ORIENTATION AND SUNSHADING OF ASIAN SCHOOLS WITH THE USE OF A HELIODON

The heliodon, a simple, inexpensive device, is used at ARISBR for qualitative study of everyday problems such as how best to orient schools in relation to sun (see Plate 1) and how to shade them. It is as useful to a school building design organisation in the tropics as a draughting board and pencil. This digest is published for those who wish to construct, calibrate and use a heliodon for their own offices.



This is a model of a school for the Chitwan district of Nepal. Orientation was determined by the need to provide the maximum amount of sun inside the building on winter mornings, and the sunshading was designed to keep out the hot summer sun.

CONTENTS

1. What is a heliodon ?
2. What it is used for.
3. How to use it.
4. How to calibrate it.

U.S. DEPARTMENT OF HEALTH, EDUCATION
& WELFARE
OFFICE OF EDUCATION
THIS DOCUMENT HAS BEEN REPRODUCED
EXACTLY AS RECEIVED FROM THE PERSON OR
ORGANIZATION ORIGINATING IT. POINTS OF
VIEW OR OPINIONS STATED DO NOT NECES-
SARILY REPRESENT OFFICIAL OFFICE OF EDU-
CATION POSITION OR POLICY

ED036118

EF 004 029

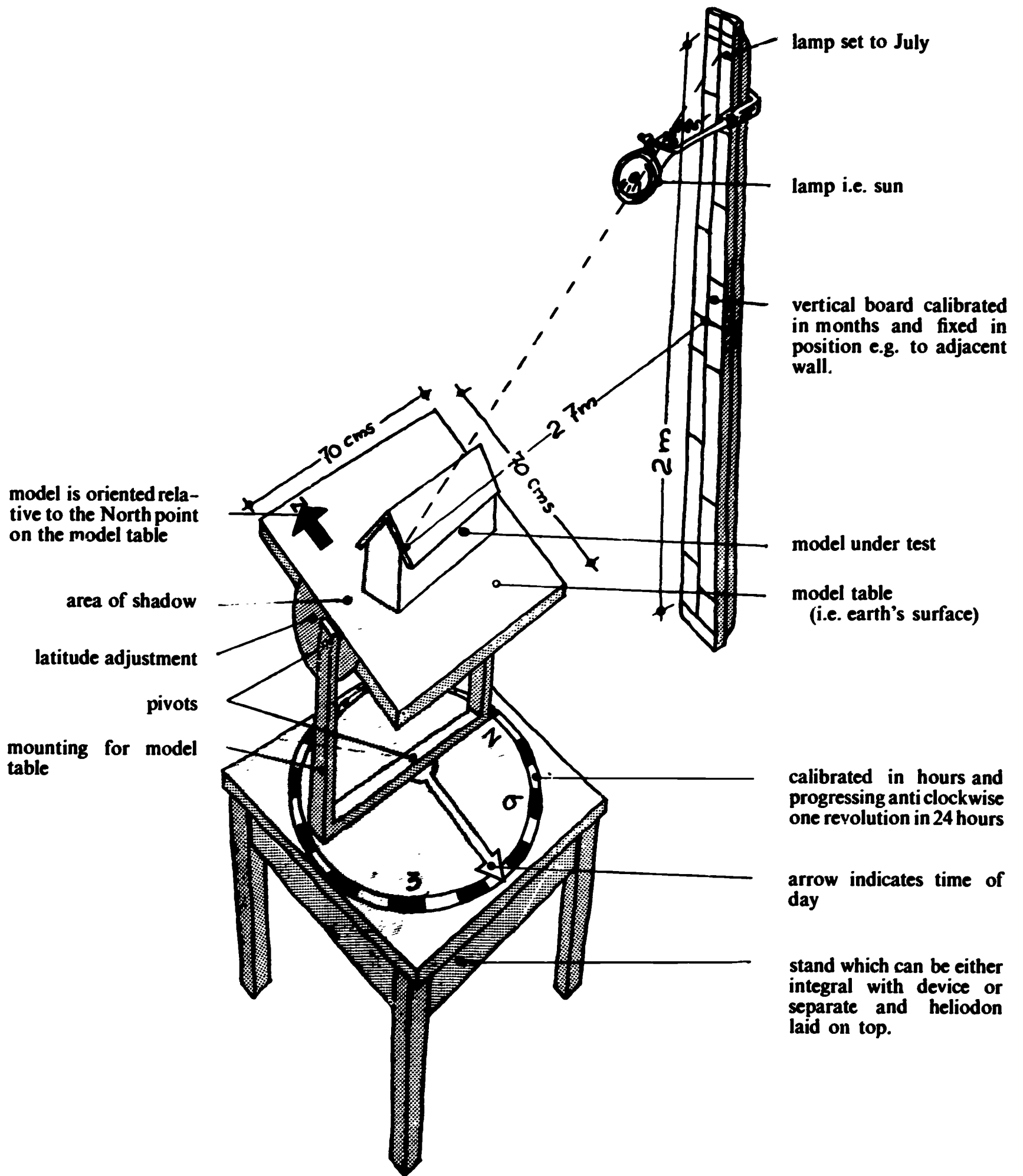

FIG. 2.

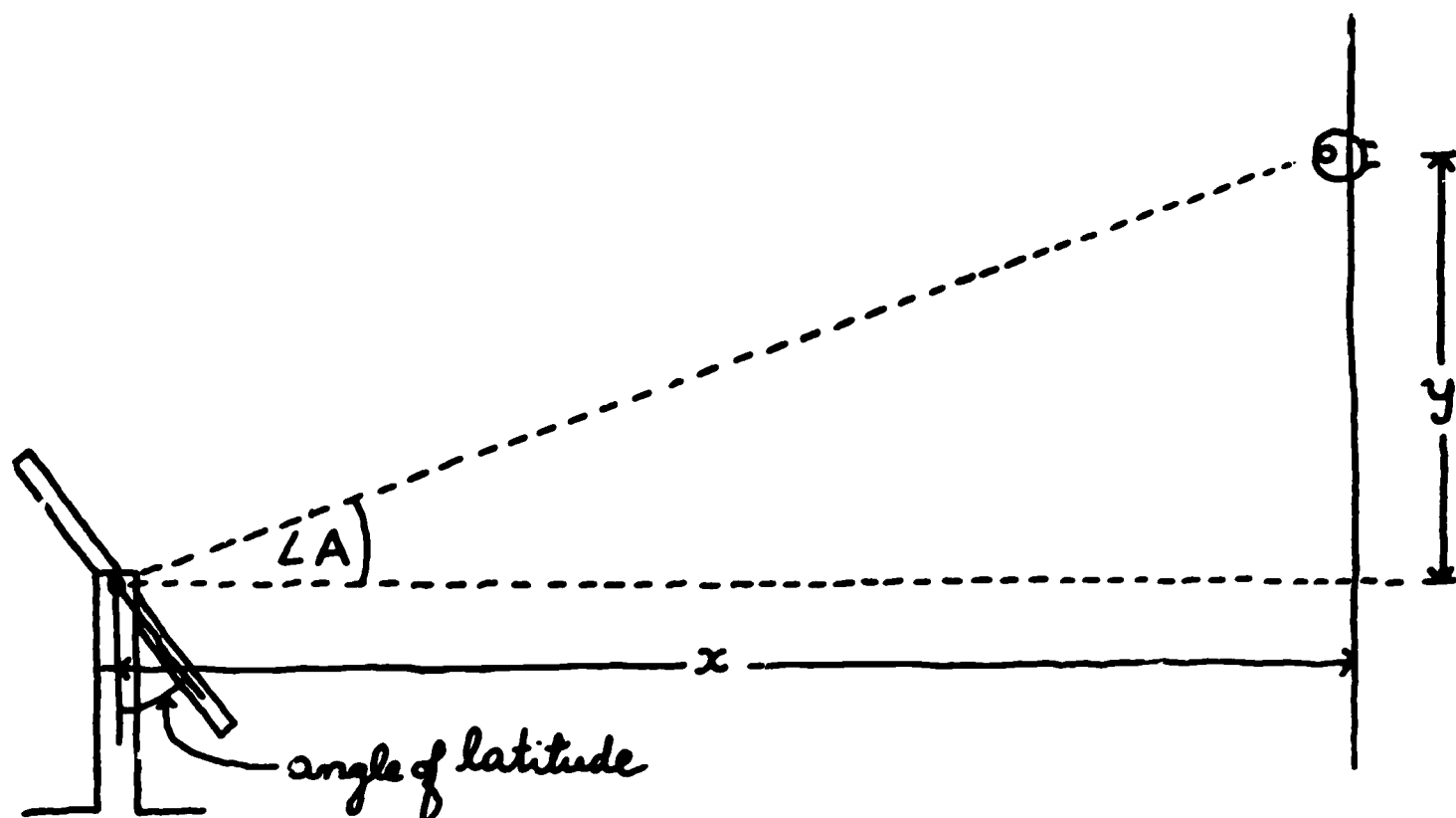

FIG. 4.

table it subtends an angle A at the centre of the model table. Thus the vertical position of the lamp on the board simulates the angle which the sun casts on that day of the year. So the vertical board can be calibrated by using a table of solar data¹ which gives the angle of the sun at various times of the year. The result of this calculation is given in Figure 5. Any heliodon with the centre point of the model table at 2.7 m from the vertical board can be directly calibrated from this.

If it is desired to have a different value for "x" the points on the vertical board between the June and December solstices will be where there is no shadow at 12 noon when the latitude adjustment is set to the Tropics of Cancer and Capricorn. The distance A between the points can be found and the results in Fig. 5 can be multiplied by a factor k where $k = A/2$ metres to calibrate any heliodon.

- (4) The fourth calibration is for diurnal rotation of the earth about its own axis. This is marked in hours and simulated by rotation of the model by a complete horizontal revolution of the model table and corresponds to a duration of twenty four hours. Direction is anti-clockwise (see Fig. 1).

¹ e.g. table 1 on p. 177 of *Architectural Physics*, by R. G. Hopkinson which gives the noon altitude of the sun at the Tropic of Cancer for the equinox, the solstices and the points midway between them.

References

- Hopkinson, R. G. *Architectural Physics; lighting*. London, H.M.S.O., 1963.
Walsh, J. W. T. *The science of daylight*. London, Macdonald, 1961.

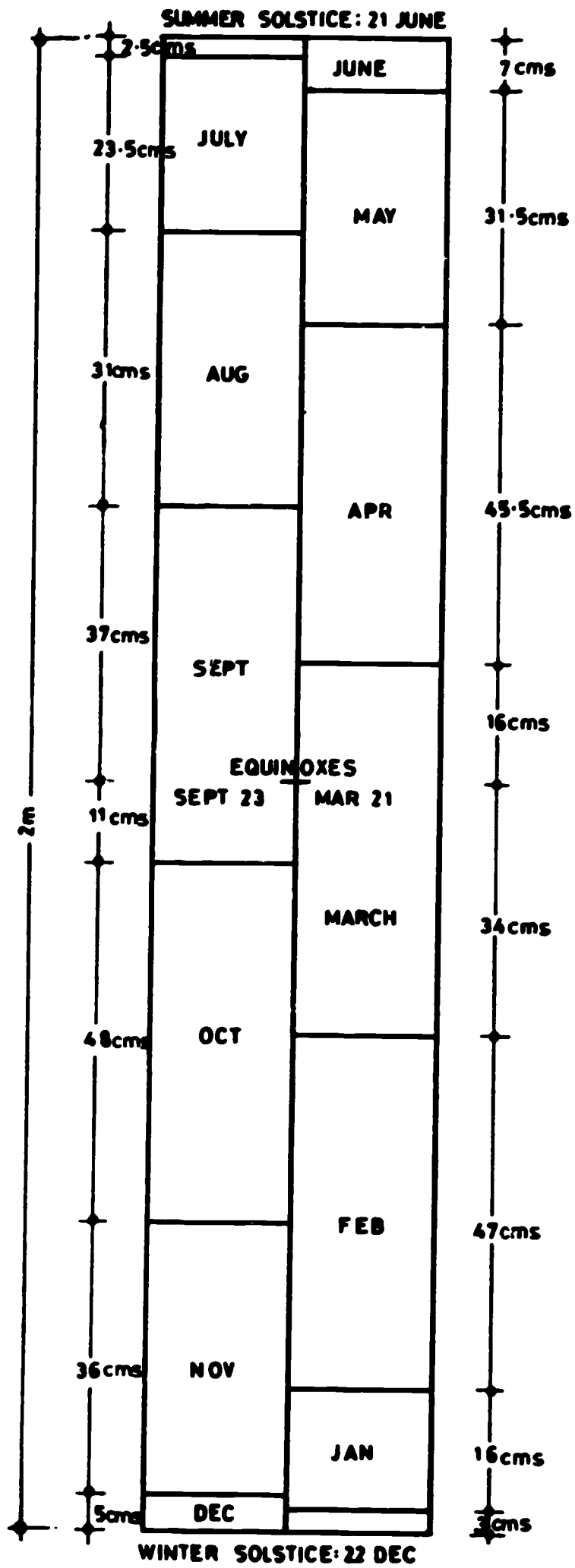

SCALE 1:10

FIG. 5.

1. What is a heliodon?

A heliodon ¹ is a device which simulates the movement of the sun. In essence it consists of a table on which an object, usually a model of a building, is placed, and a lamp (see Fig. 1). The relative positions of the table and the lamp can be adjusted to simulate any hour of the day, day of the year, and latitude. By setting the latitude adjustment one can quickly see the pattern of shadows cast throughout the day for any desired month.

2. What it is used for

The heliodon is one of various tools available to the building designer for studying the effect of sunlight and shade. Although there are many geometric methods such as sunlight protractors and sunshading diagrams ² the heliodon (which like the Pleijal Sundial uses a simulated source of sunlight directed on to a scale model of a building) is often to be preferred because the direction of the sun (i. e. the lamp) and its penetration into the building can be set for any time of year ³ and can be shown three-dimensionally, thus allowing the designer to see at a glance the behaviour of the sun for every condition. When using two-dimensional methods one has to select each condition separately and this makes it easy to overlook the condition which is, in fact, the most critical.

The results obtained from the heliodon are somewhat rough and ready and in any case can never be any more accurate than the model being used; but this is not likely to be a great drawback, due to the inaccuracy of the building process and the size of the basic units involved, which results in any calculation being "rounded up" at least to the nearest 10 cms (4") and in many cases the nearest 50 cms (1' 8") or more.

The heliodon can be used for a variety of purposes but common applications are the orientation of buildings, the design of sunshading devices, the cost of various types of sunshading such as louvres as against wide eaves and determination of areas of shadow.

3. How to use it (see Fig. 1)

- (1) fix model on model table at preferred orientation.
- (2) set angle of model table according to latitude.
- (3) set position of lamp according to month of the year.
- (4) revolve model table to observe shadow pattern at any desired time of day.

Notes

- (1) A plan of the building or group of buildings under study to the same scale as the model could be used as backing paper. This will enable cast shadows to be drawn directly on the plan.
- (2) Shadow projection can be photographed using either still or movie film.
- (3) As well as fixing the month, and observing the change in light and shade through the day, it is equally possible to fix time of day, and study the effect at the different months of the year, or to fix both hour and month and study the effect of change of latitude.
- (4) Similarly, the effect of orientation can be studied by fixing the positions of the model table and the lamp.

4. How to calibrate it

As will be seen from Fig. 1 all that is needed is a model table which will swivel in both horizontal and vertical planes and a board to which is attached a powerful projector lamp. It is important that the lamp should give a broad parallel beam.

Four calibrations have to be made. These are for (1) orientation, (2) latitude, (3) annual rotation of the earth about the sun, (4) diurnal rotation of the earth about its own axis.

- (1) Calibration of orientation consists simply of marking a North point on the surface of the model table to which models are to be fixed (Fig. 1).

1. Helos is Greek for sun.

2. See ARISBR occasional paper no. 2.

3. Hopkinson R. G. Architectural Physics; lighting, p. 35

(2) Latitude is simulated by rotation of the model table in the vertical plane. At the equinox the sun is directly overhead at noon, (see Fig. 2) and can be simulated on the heliodon as shown by Fig. 3.

When vertical, we can therefore calibrate the model table as being at 0° latitude. Also, at this time, the sun is at 90° to the poles. In other words 90° latitude can be simulated by moving the model table through 90°. This identity is true for every angle of latitude between the already established 0° and 90°.

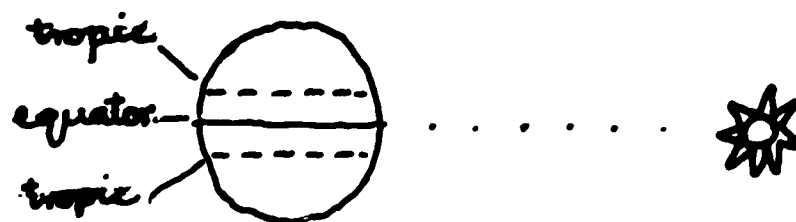

FIG. 2.

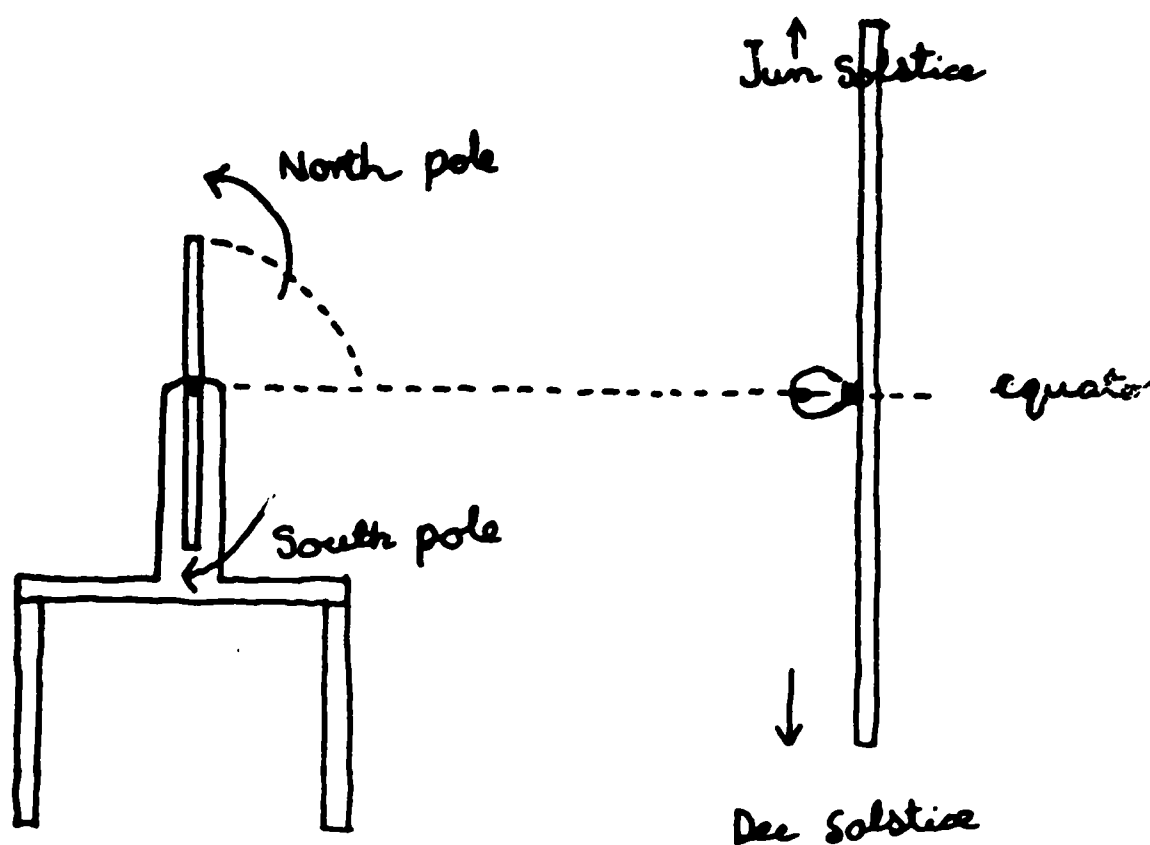

FIG. 3.

Figure 3 also shows how to distinguish between Northern and Southern latitudes. In practice it is only possible to use a heliodon with the lamp moving vertically for either Northern or Southern latitude unless two separate calibrations are made for the month of the year, one having at the top mark the June solstice, the second the December solstice.

(3) The third calibration for annual rotation of the earth about the sun is the most complex. In effect this rotation of the earth is simulated on the heliodon by a stationary earth and a sun which slides up and down in a vertical axis. Fig. 4 shows the principle behind the calibration, which is that when the lamp is set at a height y at a distance x from the model