

DOCUMENT RESUME

ED 035 217

EF 003 687

TITLE User Requirements, April 1969.  
INSTITUTION California Univ., Berkeley. Dept. of Physical  
Planning and Construction.  
SPONS AGENCY Educational Facilities Labs., Inc., New York, N.Y.  
REPORT NO URBS-DUR-5  
DNR DATE Apr 69  
NOTE 134p.

EDRS PRICE EDRS Price MF-\$0.75 HC-\$6.80  
DESCRIPTORS Bibliographies, Building Design, Building Plans,  
\*College Housing, Component Building Systems,  
\*Design Needs, \*Dormitories, Housing Industry,  
Housing Needs, Physical Environment, Research,  
\*Student Needs

ABSTRACT

In July 1964, the University of California Board of Regents authorized the project now known as URBS-The University Residential Building System Project. The initial stage in the development of the building system was the determination of the user requirements for the building type in question. This report is the result of investigation undertaken by a project team whose goals were to identify and provide the information needed for determination of user requirements for student housing. A literature search disclosed minimal available psychological data in the simultaneous observation of activity and space in residence halls. Consequently, reliance was placed on empiricism and intuition. The observations and conclusions presented came from personal interviews with students, faculty, administrators, housing offices, buildings and grounds personnel, and university architects on all University of California campuses and at other universities. (TC)

ED035217

APRIL 1969

URBS PUBLICATION

5

# USER REQUIREMENTS

U.S. DEPARTMENT OF HEALTH, EDUCATION & WELFARE  
OFFICE OF EDUCATION

THIS DOCUMENT HAS BEEN REPRODUCED EXACTLY AS RECEIVED FROM THE  
PERSON OR ORGANIZATION ORIGINATING IT. POINTS OF VIEW OR OPINIONS  
STATED DO NOT NECESSARILY REPRESENT OFFICIAL OFFICE OF EDUCATION  
POSITION OR POLICY.

UNIVERSITY RESIDENTIAL BUILDING SYSTEM

A Project of the UNIVERSITY OF CALIFORNIA

EF 003 687

ED035217

USER REQUIREMENTS  
APRIL 1969

**UNIVERSITY RESIDENTIAL BUILDING SYSTEM**

A Project of

**THE UNIVERSITY OF CALIFORNIA**

Office of the President,  
Vice President—Physical Planning and Construction  
641 University Hall  
Berkeley, California 94720

Project Director: R. Clayton Kantz, AIA

**CONSULTANT**

Building Systems Development, Inc.  
Ezra Ehrenkrantz, President  
120 Broadway  
San Francisco, California

This Project Supported By  
**EDUCATIONAL FACILITIES LABORATORIES, INC.**  
New York, New York

## TABLE OF CONTENTS

	Page
LIST OF TABLES . . . . .	vii
LIST OF PLATES . . . . .	viii
FOREWARD . . . . .	xi
ACKNOWLEDGEMENTS . . . . .	xiv
URBS PROJECT NATIONAL ADVISORY COMMITTEE . . . . .	xv
Chapter	
I. INTRODUCTION . . . . .	1
II. BUILDING SYSTEMS . . . . .	3
University Residential Building System (URBS)	
III. OBJECTIVES . . . . .	5
The Problem	
Characteristics of Present	
Student Housing at the University of California	
Objectives for URBS	
Variety and Adaptability	
Comprehensive Financial Programming	
IV. EVOLUTION . . . . .	10
European Traditions	
American Traditions	
The Characteristic Pattern of American Student Housing	
V. THE USERS . . . . .	12
Students	
Motivation and Objectives	
Conventional Groupings	
Faculty in Residence Halls	
The Administration's Role in Student Housing	
VI. HIERARCHIES OF SPACE . . . . .	22
Student Rooms	
Study	
Sleep	

- Socializing
- Dressing
- Types of Space
  - Single Rooms
  - Split-Double Rooms
  - Double Rooms
  - Triple Room
  - Four-Student Room
  - Suites
  - Apartments
- Space Allocation
  - Dimensions of Student Rooms
  - Volume and Form
- Environment
  - Thermal
  - Lighting
  - Acoustics
  - Color, Texture, Materials
  - Appliances
- Facilities
  - Bathing
  - Dining
  - Recreation and Social Activity
  - Cultural
  - Service and Storage
  - Circulation and Interrelation of Spaces

VII. ADAPTABILITY . . . . . 61

- Variety
- Change
- Student Mix
- Social Evolution
- Affluence
- Individual Student Identity

VIII. OPERATIONS . . . . . 66

- Administration
- Maintenance
  - Cleaning
  - Refinishing
  - Servicing
  - Repairs
  - Replacement
- Selection of Materials
- Maintenance Contracts
- Material Failures in Buildings

IX. FINANCE . . . . .	70
X. SUMMARY . . . . .	74
Objectives	
Evolution	
Users	
Activities and Space	
Student Rooms	
Bathrooms	
Dining Rooms	
Classrooms and Libraries	
Services and Storage	
Circulation and Interrelation of Spaces	
Controls and Regulations	
Adaptability	
Operations	
Finance	
APPENDICES . . . . .	79
Appendix I – Space Utilization in Residence Halls . . . . .	81
Appendix II – Cost Per Student Space . . . . .	83
Appendix III – Hierarchical Patterns . . . . .	85
Appendix IV – Area Requirements—Furniture . . . . .	99
Appendix V – Planning Studies—Single and Double Rooms . . . . .	107
Appendix VI – Planning Studies—Offset and Non-Rectilinear . . . . .	111
Appendix VII – Adaptability Studies—Structural Spans . . . . .	117
CREDITS . . . . .	121
BIBLIOGRAPHY . . . . .	125

## LIST OF TABLES

Table	Page
1. Percentage of Students Accommodated in University Housing on Each Campus . . . . .	8
2. Percentage of Undergraduate Respondents Living in University Residence Hall, 1963-1964 Academic Year . . . . .	17
3. Comparative Study of Area Requirements . . . . .	28
4. Recommended Space Standards Per Student from a Group of Recent Studies . . . . .	43
5. 1966 Student Room and Board Costs (per year, in double room) . . . . .	70
6. Illustrative Model, Future Student Room and Board Costs . . . . .	71
7. Illustrative Model, Future Student Room and Board Costs . . . . .	71



## LIST OF PLATES

Plate	Page
1. Building Systems . . . . .	4
2. Built-in Closets at Entry to Double Room . . . . .	29
3. Double-Room Arrangement, University of Delaware . . . . .	30
4. Typical Trailer Plan, Eight Students, University of California, Santa Cruz . . . . .	32
5. Suite Organization 1 . . . . .	33
6. Suite Organization 2 . . . . .	34
7. Suite of Five Double Rooms Around Common Space . . . . .	37
8. Four-Student Apartments (Michigan State University and Indiana University) . . . . .	38
9. Group of Dining Rooms Served by One Kitchen, Indiana University . . . . .	40
10. College Plans-Stiles College, Yale and St. Olaf's College, Minnesota . . . . .	42
11. Gang Bathrooms . . . . .	49
12. Large Dining Room, Divisible by Operable Partitions into Three Rooms of Varied Sizes . . . . .	50
13. The Large Lounge . . . . .	52
14. Small Living Rooms for Groups of 6-8 Students . . . . .	53
15. "Date" Rooms and Lounge Facilities . . . . .	54
16. Hierarchy Diagram, Double Loaded Corridor, High-Rise Building . . . . .	58
17. Ratios of Circulation to Gross Area . . . . .	59
18. Variety in a High-Rise: Plan of Floors 2-12 Showing Varied Shapes of Rooms . . . . .	62
19. Variety in a High-Rise: Plan of Floors 13-15 Showing Student Apartments and Changed Bathroom Arrangement (University of Colorado, Boulder) . . . . .	63
20. Typical Residence Floor Plan, Residence Hall 3, Priestly Hall, Berkeley . . . . .	86

21.	Typical Residence Floor Plan, Residence Hall 5, Ryerson Hall, Davis . . . .	87
22.	Typical Residence Floor Plan, Residence Hall 6, Regan Hall, Davis . . . . .	88
23.	Typical Residence Floor Plan, Residence Hall 3, Hedrick Hall, Los Angeles . . . . .	89
24.	Typical Residence Floor Plan, Residence Hall 4, Lothian Hall, Riverside . .	90
25.	Typical Residence Floor Plan, Residence Hall 2, Anacapa Hall, Santa Barbara . . . . .	91
26.	Typical Residence Floor Plan, Residence Hall 1, Mesa Court, Irvine . . . .	92
27.	Typical Residence Floor Plan, Residence Hall 1, Revelle Hall, San Diego (Lower Floor Plan) . . . . .	93
28.	Typical Residence Floor Plan, Residence Hall 1, Revelle Hall, San Diego (Upper Floor Plan) . . . . .	94
29.	Typical Residence Floor Plan, Residence College 1, Cowell College, Santa Cruz . . . . .	95
30.	Typical Residence Floor Plan, Residence Hall 2, Stevenson College, Santa Cruz . . . . .	96
31.	Typical Residence Floor Plan, Stern Hall, Berkeley . . . . .	97
32.	Basic Residence Hall Plan Types . . . . .	118
33.	Basic Residence Hall Plan Types (continued) . . . . .	119

## FOREWORD

Before World War II, the University of California accommodated only a thousand students in University-owned residence halls. These halls, financed by private benefactors, were located at Berkeley, Davis, and Los Angeles. As a result of staff investigations made during and just after the war, a report titled "Some General Considerations For . . . Adequate Residence Halls" was published in 1947 and revised in 1950. On the basis of this report, a pilot housing facility was constructed at the Davis campus, opening in 1951.

In June 1954, the University-wide Office of Architects and Engineers published a "University of California Residence Hall Study." This study guided residence hall construction from 1957 until early 1963. The report stated:

It shall be a basic philosophy of University residence halls to provide more than just food and shelter. The residences must create in the students an atmosphere of respect and pride in their surroundings. They should foster stable standards of conduct and promote harmonious group life, all toward contributing to the broad education of the student.

Thus, education became a major, and perhaps the prime, justification for University-operated residence halls.

In May 1957, The Regents established a University-wide residence halls program. Using HHFA funds, 6,100 spaces were constructed and placed in operation by 1960. In 1960, an additional 3,500 spaces were financed.

By 1962, the University was seeking more economical ways to build residence halls in order to keep student room and board rates low. Rates were rising not only because of increased costs of construction and operation, but because State of California financial support for residential facilities was being withdrawn.

A "Report on University of California Student Housing Program" was issued in September 1962. It dealt largely with financial considerations, and while calling attention to the difficulties ahead, the report nevertheless recommended continuance of the housing program through 1965 construction.

A year later, in September 1963, the University-wide Office of Analytical Studies reported on the number of students that should be housed in University facilities, noting that in the absence of sufficient rooms and board facilities, students were turning increasingly toward apartment living. The report gave special attention to the goal of housing 50 percent of the single students at all campuses (except 25 percent at the urban campuses of Berkeley and Los Angeles). It concluded that, because demands for residence space vary significantly by campus, a "25%-50%" policy would be difficult to realize operationally. This report, often referred to as the "Tyndall" report after its author (David Gordon Tyndall), covered the five major campuses at Berkeley, Davis, Los

Angeles, Riverside, and Santa Barbara. It was submitted to The Regents in November 1963.

These various reports dealt with critical but relatively isolated issues and problems: general philosophy, room and board rates, number of units, etc., and reflected the gradual accumulation of experience, information, and expertness in the area of student housing.

Concurrently, in September 1963, Vice President—Physical Planning and Construction, Elmo R. Morgan, appointed an Ad Hoc Committee on Residence Hall Operations. The committee was composed of deans of students, residence hall administrators, business officers, and campus architects from the various campuses. Its objective was the study of such fundamental matters as programs, administrative structure and management, financing and accounting, operations, architectural design and construction, and their separate and total effect on initial cost, operating cost, and room and board rates.

The report of this Ad Hoc Committee was presented to and accepted by The Regents in May 1964. The report recommended means for increasing net revenues, proposed uniform and more efficient accounting systems, suggested additional studies as to the feasibility of providing a variety of accommodations, and recommended reexamination of the program before constructing additional facilities.

In July 1964, The Regents authorized the engagement of The Real Estate Research Corporation to survey students' preferences and needs. Its report, "Analysis Student Housing Market and Alternative University Housing Programs, 1963-1975," was summarized and related to projected private housing supply. This analysis was used to recommend specific building programs for each campus. These findings were integrated with the work of the Ad Hoc Committee, resulting in the "Comprehensive Housing Report, April 1965." Presented to The Regents, although not adopted by them, it did succeed in raising the level of awareness to the complex network of problems underlying the student housing program.

In October 1965, The Regents authorized the project now known as URBS—the University Residential Building System project. Financed jointly by The Regents and the Educational Facilities Laboratories, Inc., the URBS project intended to develop a building system for use in the construction of between 4,500 and 9,000 student spaces over a period of three years, utilizing the building components developed through the project efforts. The initial stage in the development of the building system was the determination of the user requirements for the building type in question.

This report, URBS USER REQUIREMENTS, is the result of investigations undertaken by a project team whose goals were to identify and provide the information needed for determination of user requirements for student housing. A literature search disclosed minimal available psychological data in the simultaneous observation of activity and space in residence halls. Consequently, reliance was placed on the acceptable tools of architecture for environmental evaluation—empiricism and intuition. The observations and conclusions presented here came

from observations made at the University of California, as well as at universities and colleges throughout the country.

Personal interviews with students, faculty, administrators, housing officers, buildings and grounds personnel, and university architects were conducted on all University of California campuses and on other university campuses. The team for this investigation was composed of University administrators: Norman M. Better, Associate Director, Relations With Students; John E. Forsberg, University Housing Supervisor and past president of Association of College and University Housing Officers; R Clayton Kantz, URBS Project Director; and consultants, Ezra Ehrenkrantz, Chris Arnold, and Peter Kastl of Building Systems Development, Incorporated.

It should be noted that Chris Arnold, a graduate of Cambridge University and London University, England, contributed historical background and information regarding the residential college concept in British universities.

## ACKNOWLEDGEMENTS

We are grateful to the many people throughout the nation who so willingly provided information through correspondence or personal interviews. The cooperation and response received indicates a mutual concern relating to the programming and construction of physical facilities for our respective institutions.

We especially appreciate the assistance and support from the URBS National Advisory Committee with special thanks to Fred A. Schwendiman, Director Auxiliary Services, Brigham Young University, who provided valuable assistance throughout the collection of data.

### PARTICIPATING UNIVERSITIES AND COLLEGES

Brigham Young University, Provo, Utah  
California State College at Long Beach  
Indiana University, Bloomington  
Michigan State University, Lansing  
Parsons College, Fairfield, Iowa  
Pennsylvania State University, University Park  
Purdue University, Lafayette, Indiana  
St. Olaf College, Northfield, Minnesota  
Skidmore College, Saratoga Springs, New York  
Stephens College, Columbia, Missouri  
University of Colorado, Boulder  
University of Michigan, Ann Arbor  
University of Minnesota, Minneapolis  
University of Washington, Seattle  
University of Wyoming, Laramie  
Wichita State University, Wichita, Kansas

## URBS PROJECT NATIONAL ADVISORY COMMITTEE

Mr. Elmo R. Morgan  
Vice President—Physical  
Planning and Construction  
University of California  
(Chairman)

Dr. Louis T. Benezet,  
President  
Claremont Graduate School  
and University Center  
Claremont, California

Mr. Frank Burrows  
Williams and Burrows,  
General Contractors  
Belmont, California

\*Mr. Jay DuVon  
Director, Division of  
College Facilities  
U.S. Office of Education  
Washington, D. C.

Mr. Paul Emmert  
Community Facilities  
Administration  
Washington, D. C.

Mr. Robert L. Geddes,  
A.I.A.  
Geddes, Brecher,  
Qualls & Cunningham  
Philadelphia, Pennsylvania

Mr. Jonathan King  
Vice President and Treasurer  
Educational Facilities Laboratories, Inc.

\*Deceased

Mr. Cornelius J. Haggerty  
President, AFL—CIO  
Washington, D.C.

Mr. William LeMessurier  
LeMessurier and Associates  
Boston, Massachusetts

Mr. Donald E. Neptune, A.I.A.  
Pasadena, California

Mr. Walter Andrew Netsch,  
A.I.A.  
Skidmore, Owings and  
Merrill  
Chicago, Illinois

Professor Theodore Newcomb  
Department of Psychology  
University of Michigan  
Ann Arbor, Michigan

Mr. Fred A. Schwendiman  
Director, Auxiliary  
Services  
Brigham Young University  
Provo, Utah

Mr. Robert Shaffer  
Dean of Students  
University of Indiana  
Bloomington, Indiana



## I. INTRODUCTION

University-owned and operated residence halls are now recognized as an essential component of the academic environment. The magnitude of student housing requirements in the next decade leads to the conclusion that residence hall construction will become an increasingly significant item in the University budget. It has been estimated that U. S. colleges and universities will spend approximately fifteen billion dollars in the next decade on student housing. With expenditures of this magnitude, economies that can save even a small percentage of total costs could total millions of dollars. At the same time, it is recognized that conventionally designed residence halls often have failed to meet even basic user needs and that new approaches to the fulfillment of these needs are imperative.

The scope and complexity of the student housing program at the University of California led to the conviction that a more systematic approach was needed. In response to this need, the University Residential Building System (URBS) project was created in an effort to seek an improved approach to obtaining environmental improvements at the lowest practicable cost, and to do so with built-in adaptability that could substantially postpone obsolescence resulting from changing user requirements.

The initial objective of URBS was the development of detailed performance specifications for those functional sub-systems and components of residence halls that are most directly involved in fulfilling user requirements. To accomplish this objective, an in-depth analysis of user requirements was first performed to identify those environmental factors that could be improved through improvements in physical layout and design. This report, URBS USER REQUIREMENTS, represents the findings and conclusions resulting from that analysis.

The fundamental conclusions and assumptions made to date by URBS are as follows:

- A careful analysis of user requirements can assist building programmers in meeting future needs.
- The traditional design approach, wherein building products readily available from industry are used, usually results in a satisfactory building at occupancy, but such buildings are most difficult and expensive to alter to accommodate changing user requirements.
- Functional sub-systems and building components can be designed for greater compatibility. For instance, they can eliminate unnecessarily intricate ducting and piping for heating and ventilating systems that increase construction costs and reduce building flexibility and adaptability.
- Industry, given appropriate incentives, will risk its capital on the research and development of new products and components that can meet performance specifications based upon user requirements.



- New components and techniques can be developed that provide the student with greater expressive control over his own environment.
- Performance specifications for functional sub-systems and components can be developed, reflecting user requirements and the need for adaptability, without compromising either the exterior appearance of the buildings or their placement on the site. Moreover, such performance specifications will not impair the cherished architectural individuality of each campus.
- Through the development of new products and through the standardization of selected, functional sub-systems and components, the degree to which user requirements and the number of available options can be fulfilled, can be expanded. Also, student rental fees can be maintained at levels that are at the very least competitive with those of private housing.

## II. BUILDING SYSTEMS

### A. UNIVERSITY RESIDENTIAL BUILDING SYSTEM (URBS)

This project expects to encourage industry to do research and development work on new building products specifically for use in university student housing. The large market, coupled with new bidding procedures based on performance specifications, makes it possible for each manufacturer to bid in a protected manner on his own research and development work.

The URBS project focuses on functional sub-systems and components used in buildings, rather than the design of complete rooms or buildings. The major building components involved will be Structure-Ceiling, Heating-Ventilating-Cooling, Partitions, Bathrooms, and Furnishings. (See Plate 1.) These components will account for approximately 50 percent of the building cost. Other subsidiary components may be added where it is felt to be appropriate and advantageous. The remaining (non-URBS) portion of the building will be designed by executive architects using conventional products. The non-URBS portion includes the building's exterior walls, fenestration, roofing, foundations, distribution of all utilities, building equipment other than HVC, elevators and floor and window coverings. Construction for the total building will be by general contractors in the traditional manner. Except for distribution of utilities, the non-URBS elements vary considerably campus by campus, reflecting individual character.

To force these elements into the URBS system might compromise the cherished individuality of each campus, hence their omission. Solution of utilities distribution problems depends on local labor jurisdiction as well as a wide variety of local engineering preference.

The precedent for the URBS project is the School Construction Systems Development (SCSD) project<sup>1</sup> in which thirteen California school districts are grouped together develop a system of components for high school buildings.

The URBS USER REQUIREMENTS emphasizes those aspects of the student-housing problem that are most relevant to the building system approach. Items of an administrative or operational nature are included only as they affect the system design. Problems such as site layout, building density, and parking, which are of the utmost importance to the design of student housing, are regarded as problems for the individual campuses and the executive architects for each building group.

<sup>1</sup>Educational Facilities Laboratories, Inc., *SCSD The Project and the Schools*, New York: Educational Facilities Laboratories, Inc., May 1967

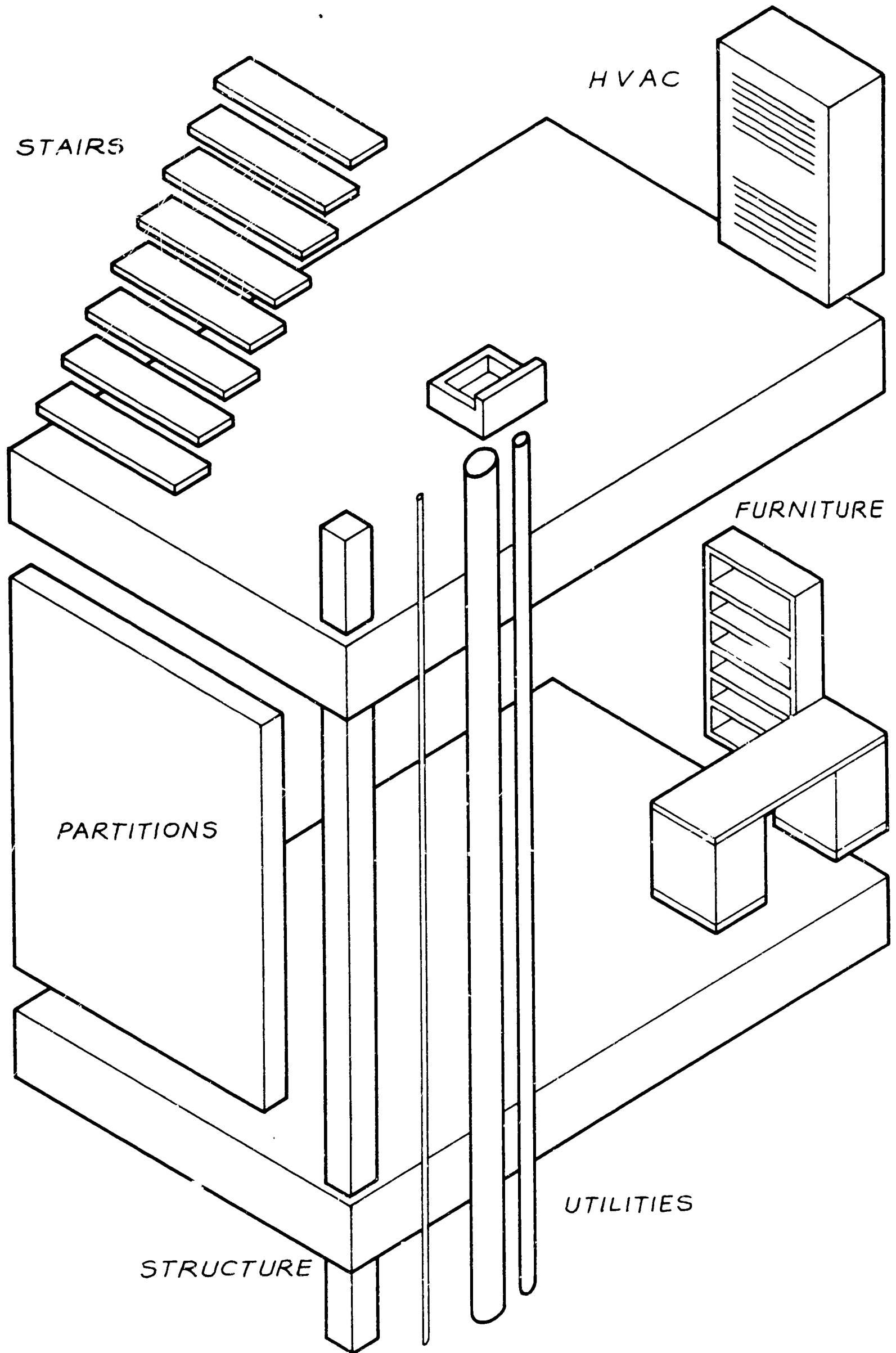

### III. OBJECTIVES

#### A. THE PROBLEM

Student housing at the University of California is constructed with borrowed money. A policy of soundly financed student housing is maintained by using student rental charges to amortize construction loans over a period of forty years. Efficient administration of the student housing programs requires a high level of occupancy for at least four decades at rates that are adequate to maintain the buildings and to amortize construction loans while still being competitive with private housing. The economic viability of the University housing program is in jeopardy if student disapproval and/or market competition result in a low rate of occupancy. Therefore, it is of primary concern that University student housing be physically planned to recognize student preferences and needs, to provide a variety of accommodations, and to embody the flexibility necessary to adapt the building to future changes in user requirements.

Traditionally, the design of buildings at the University of California has consisted of an attempt to initially anticipate student needs and preferences over forty years, using conventional building components and construction techniques. A possible alternative to this approach would be to provide built-in flexibility in anticipation of changing student needs and preferences while maintaining initial construction costs within reasonable bounds. The URBS project was created with the objective of exploring the possibilities of a more flexible type of construction that will better accommodate present and future student occupants. Major factors affecting the development of a building system are as follows:

1. The correction of physical aspects (such as poor acoustics—whether due to deficiencies of material or inability to afford good treatment) which present functional problems in the buildings. Other aspects concern design and planning problems. For example, standardization of appearance and lack of variety in choice are unappealing to students.
2. The needs for both variety and adaptability cannot be overemphasized. They are not being satisfied with conventional design and construction techniques. Present-day students have a strong desire to express their individuality, and the environment in which that individuality can be expressed is of genuine concern to them.
3. Students are disenchanted with present student housing. This disenchantment results from objections to University housing regulations and discontent with the accommodations. Although the former is a problem of importance, little improvement can be achieved through the development of a building system. The URBS project is concerned with a search for solutions to those objections created by the *physical* deficiencies of present-day student housing.

4. Rising student rental charges threaten the viability of University-owned and operated student housing. Colleges and universities will not be exempt from the increased operating and construction costs resulting from the rise in the costs of goods and services being experienced by all segments of society.<sup>2</sup> It is the aim of URBS to systematize construction in key functional areas to reduce initial construction costs without sacrificing quality and to achieve reduced maintenance and operating costs, thereby forestalling increases in student fees.

## B. CHARACTERISTICS OF PRESENT STUDENT HOUSING AT THE UNIVERSITY OF CALIFORNIA

Within recent years, the University of California has moved toward providing a living situation that strives to bridge the gap between curricular and non-curricular activities. The residential college concept, used in planning the University of California at Santa Cruz, combines learning and living and seeks to reinforce student-faculty contacts. Chancellor Dean McHenry, in support of the residential college concept, quotes Christopher Jencks and David Reisman:

...students and faculty associating in these residential units can do much to educate each other in ways not encouraged by the formal curriculum.<sup>3</sup>

The residential college plan is unique to the Santa Cruz and San Diego campuses of the University of California, but the integration of social and cultural enrichment into residence hall life has become a recognized and precious goal of the total educational process.<sup>4</sup>

The University has implicitly adopted a policy that no student should be prevented from attending the University because he cannot find housing within his financial resources.<sup>5</sup> An attempt is made to provide approximately one-quarter of the total housing need—that portion not provided by private enterprise.

Housing is provided on a room and board contract basis, and at a relatively uniform rental for all campuses of the University. Students with single-room accommodations pay more than those accommodated in double rooms, and there are some minor differences in rental fees from campus to campus due to special conditions.

---

<sup>2</sup>Ronald A. Wolk. *Alternative Methods of Federal Funding for Higher Education*, p. 67, 1968.

<sup>3</sup>Dean E. McHenry. "Small College Program for a Large University, *College and University Business*, Vol. 37, No. 1, July 1964.

<sup>4</sup>*An Academic Plan for the University of California*. Approved in principle by The Regents of the University of California, July 1961, pp. 4-5.

<sup>5</sup>"As a matter of educational policy, the University (should do all in its power gradually to provide residential facilities for as high a proportion of its students as may wish to live on campus during their University studies." *Proceedings of the University of California Sixteenth All-University Faculty Conference*, March 27, 28, and 29, 1961, p. 48.

Table 1 shows the percentage of students accommodated in University-owned and operated residence halls on each campus in relation to the total number of students attending classes. Appendices I and II show statistical data, cost information, and plan configurations for a representative group of University of California student housing projects covering the range of accommodations provided to date (through 1966).

### C. OBJECTIVES FOR UNIVERSITY OF CALIFORNIA STUDENT HOUSING

Long-range goals of the University student housing program are set forth in the report issued by the Ad Hoc Committee on Residence Halls in 1964:<sup>6</sup>

The sole purpose of residence halls is to serve in the best possible way the students who live therein.

To meet student needs, the University must first provide diversity in residential housing, simplicity in design, low room and board costs, a minimum number of rules, and cultural and social programs related to the academic purposes of both the student and his university.

In 1966, these goals were translated into more specific requirements for the URBS project by the Standing Committee on Residence Halls.<sup>7</sup> URBS was asked to provide for:

1. Single and married student housing, both undergraduate and graduate.
2. Low-rise and high-rise buildings on both level and sloping sites.
3. Architectural design freedom.
4. Inclusion of academic, social, recreational, and cultural activities.
5. Reduction of construction, operations, and maintenance costs at current target levels.
6. Opportunity for students to live as inexpensively as possible.
7. Student preference in such terms as privacy, student conditions, freedom, and comfort including appropriate environment—acoustical, thermal, and lighting.

Under the conventional method of constructing one project at a time, it is difficult, if not impossible, to fulfill many of these requirements simultaneously within a restricted cost context. Although these requirements are not dependent on a building system for their fulfillment, the intent of URBS is

<sup>6</sup>University of California. *Report on the Ad Hoc Committee on Residence Hall Operations*. April 30, 1964.

<sup>7</sup>University of California. UC Standing Committee on Residence Halls, meeting of August 29 and 30, 1966, Hilton Inn, San Francisco International Airport.



TABLE 1

**PERCENTAGE OF STUDENTS ACCOMMODATED IN UNIVERSITY-OWNED  
AND OPERATED RESIDENCE HALLS ON EACH CAMPUS IN RELATION  
TO THE TOTAL NUMBER OF STUDENTS ATTENDING CLASSES**

	Berkeley	Davis	Irvine	Los Angeles	Riverside	San Diego	San Francisco	Santa Barbara	Santa Cruz	TOTAL
Groups A and B Existing Housing Units (Spring 1966), Single Student	3,520	2,917	815	3,628	1,234	1,194	365	2,668	1,616	17,957
Students on Campus, Undergraduate	17,991	8,599	2,960	18,693	3,412	2,066	361	10,857	2,503	68,042
Percent of Undergraduate Students in University Housing	19.6	13.9	27.3	19.4	36.1	44.7	101.1	24.5	64.5	26.4
Groups A and B Existing Housing Units (Spring 1966) Married Student	920	476	200	646	275	210	165	250	0	3,142
Students on Campus, Graduate	10,141	2,854	1,163	10,304	1,151	1,159	2,050	1,762	99	30,683
Percent of Graduate Students in Married Student Housing	9.1	16.7	17.1	62.7	23.9	18.1	8.5	14.2	0	10.2
Total Housing	4,440	3,393	1,015	4,274	1,509	1,404	530	2,918	1,616	21,099
Total Students	28,132	11,453	4,123	28,997	4,563	3,825	2,411	12,619	2,602	98,725
Percent of Total Students in University Housing	15.8	29.6	24.6	14.7	33.1	36.7	22.0	23.1	62.1	21.4

SOURCES: University of California, Office of the President, Vice President Planning and Analysis, Fall 1968.

to expand the degree to which these requirements can be fulfilled and to increase the number of options available within economic restraints.

#### D. OBJECTIVES FOR URBS

URBS is an experiment in raising the environmental quality of student housing—in both design and construction—at the University of California. The intent is to make housing more responsive to the needs of all the users over a longer time period. These needs focus on two related problems: (1) to provide more variety in immediately available living arrangements and (2) to allow for adaptability to meet the changing needs of the future. Existing financial parameters call for a solution to these problems within a long-term cost context which includes construction, maintenance, and operations costs.

##### 1. Variety and Adaptability

The goals of present variety and future adaptability must be achieved within an economic context that does not place an unfair burden on the students.

The attainment of variety is an immediate goal desired by the students. It is dependent upon several factors, including wall materials that permit individualized decorative coverings and choice of room sizes to accommodate various types of desired group living arrangements.

Adaptability is a long-term goal designed to meet changing student needs. It would permit such changes as the conversion of a building with the conventional single and double room layouts into suites of various sizes. Even such radical conversions as a changeover from single to married student housing could be accomplished easily and inexpensively with a building system designed for future adaptability.

##### 2. Comprehensive Financial Programming

The opportunities presented are dependent for their achievement on comprehensive programming.

At present, student housing is constructed at the various campuses of the University of California, and elsewhere around the country, on a basis related primarily to the first cost of the building, with little or no emphasis on maintenance and operation costs. A basis taking all three factors into account will find certain efficiencies in the long-term cost program derived from an additional initial expenditure, thus making possible a reduction in the actual costs to the students throughout the life of the building.

These goals require an increase in the levels of building performance and sophistication at the same time that there is a call to reduce the costs of building and operating. It is the prime URBS objective that the cost to the student may be held constant while the performance levels of the building he lives in are increased.



## IV. EVOLUTION

The search for appropriate answers to the problems in university student housing today can be initiated by a review of the context from which present forms have arisen.

### A. EUROPEAN TRADITIONS

Two strong traditions dominate the European view of the student in relation to his university—one is English; the other is Continental-European, seen characteristically in Germany.

In England, the university has been considered an academic community for hundreds of years. The student gains as much of his education from his fellows and his daily life around the university as from the specific lectures and courses which he attends. This characteristic pattern emerged in the old universities of Oxford and Cambridge. In these communities the student's allegiance is to his college as much as to his university. The English college is small (150 to 400 students) and is a tightly knit organism of students and academic fellows living and doing much of their academic work together. Student college life is intimate, and the physical surroundings are small in scale. In Oxford and Cambridge, the entrances to the colleges are unobtrusive doorways opening onto the town streets; thus university life is closely mingled with the life of a busy, small town.

Another pattern of English college life, less familiar to us, is the one created by the later civic universities in the Midland industrial cities, in London, and in other smaller cities around the British Isles. These universities were created primarily to benefit local students who lived at home and attended a local college. As time passed, and the universities drew from a much wider radius, social life changed, and the need for the student to be part of an academic community and to live within its auspices became desirable. These institutions did not develop along college lines as in the older universities. Instead a pattern developed similar to that of the American university although on a much smaller scale.

The last few years have seen a mushrooming of new universities across Great Britain. These look to the old universities and to some of their newer forebears for ideas, with many imaginative, new patterns of academic life, thought, and living being tried.

The Continental tradition, particularly in Germany, separated the living situation from the academic. It was felt that the department and the lecture hall represented a life quite apart from where the student ate and slept. The university felt no responsibility for the student's living accommodation, and the student was left to fend for himself in the lodging houses and homes of the town.

## B. AMERICAN TRADITIONS

Some of the first Eastern private American universities followed the older British model. Houses at Harvard and Yale followed the pattern of a university for aristocracy—well endowed both academically and financially. The intimate scale and the high level of accommodation of this model has been followed even to this day when social patterns are changing rapidly.

The larger state institutions, on the other hand, tended at first to follow the German model and not to involve themselves in housing their students. This pattern has changed. Now the giant state systems are heavily involved in student housing on a scale unknown in Europe. This growth has occurred particularly since the Second World War, creating a radical diversion from the scale of the Eastern college and its English forebear. Huge complexes of student cities have been built and are continuing to be built. The scale of the student housing complex parallels the scale of the campus itself.

## C. THE CHARACTERISTIC PATTERN OF AMERICAN STUDENT HOUSING

From this mixed background, a pattern of housing characteristically American has emerged. It appears to derive from the twin concepts of economy and appropriate social patterns. The pattern is one of identical rooms opening off from each side of a corridor, each room holding two students, with a number of rooms grouping together to form a floor or a "house" that shares certain facilities such as bathrooms and lounges. A familiar related pattern is that of the modern hotel and motel. The arguments for this standardized layout, the identical rooms with two students to a room (rather than a private room for each student) are, of course, economic. There is also a rather deep-seated feeling that it is socially desirable for two undergraduate students to be together. The college roommate has become a traditional figure of fact and fiction.

This pattern, which emerged perhaps by default rather than from conviction, is now being scrutinized. The huge student cities composed of buildings whose differences are confined primarily to their exterior materials are doubtful contributors to the academic community as an ideal. The student of today seems less ready to accept an imposed formula and to be more interested in the expression of his individuality. The student can scarcely be blamed for taking this attitude since a traditional objective of higher education is the development of the individual's capabilities and interests. The other major concern is the physical aspect of the huge scale of our institutions and the effect this may have on the students. There is growing interest in those physical forms of buildings and campuses which break down the scale into something more intimate and meaningful to the individual. Present trends lean heavily toward the English ideal of the academic community in which the student plays an individual role among his peers and his academic superiors. We have moved from the idea of a dormitory to that of a residence hall, and we are now moving towards that of a community.

## V. THE USERS

The initial step in the development of a new building system is to establish the range of user requirements to be met by that system. Consultations with students assigned to various categories provided the basis for determining URBS user requirements.

Also consulted about particular needs were representatives of: (1) the faculty, since more academic activity is being brought to residence buildings; (2) the administration, with its continuing problems in policy, operation, and management, and (3) the buildings and grounds departments which are charged with maintenance of residence halls.

### A. STUDENTS

#### 1. Motivation and Objectives

For this study, a student typology of two groupings has been used: (1) the grouping, favored by the sociologists and academicians, directed to motivation and objectives, and (2) the grouping, of interest to administrators and planners, which stresses age groups of classes, sex, and marital standing. Both groupings are of interest, but possibly the latter provides more tangible evidence by which to judge the physical environment.

The sociologists' and academicians' typology has been the subject of increasing investigation in the last decade. Notably, Clark-Trow (1963)<sup>8</sup> Newcomb (1943)<sup>9</sup> and Jencks-Riesman (1962)<sup>10</sup> find their place in our considerations.

The Clark-Trow typology was selected for the basis of discussion herein, because the observations were made in part at the University of California. This is not to say there is significant regionalism of types, but rather that there is familiarity on our part. The types of interest to us are the collegiate, vocational, academic, and nonconformist.

The *collegiate* appears to be motivated by the social aspects of university life. His symbols are extracurricular activities—social weekends, dances, and athletics. He identifies more strongly with the university than with its academic purposes. Riesman notes that his achievement is adequate but without apparent objective. Since he is the most conservative and represents the majority of college students, student housing tends to be primarily designed for him. College administrators are inclined to establish him as the norm. Housing for

---

<sup>8</sup>Burton R. Clark and Martin Trow. *Determinants of College Student Sub-Cultures*. 1963.

<sup>9</sup>T. M. Newcomb. *Personality and Social Change*. New York: Dryden Press, 1943.

<sup>10</sup>Nevitt Sanford, ed. *The American College*. New York: John Wiley and Sons, 1962.

this student type need only provide durable custodial accommodations, with sufficient recreational facilities within close proximity. He needs a space not dissimilar from his bedroom at home, containing quantities of storage space for clothes and equipment

The *vocationally oriented* student represents the next largest block of students. His whole college motivation is to acquire sufficient skills to obtain a job within his maximum potential, with resulting maximum monetary return. His campus symbol is the student placement office. He is apt to be married and to hold a job 20 to 40 hours a week. The vocationally-oriented comprise the majority of occupants of married student housing. The vocational student has little time for "broadening" courses and concentrates on acquiring a diploma. His participation in graduate programs is toward higher job achievement and is largely limited to the professional schools. He will accept almost any housing as long as it is inexpensive and does not distract him from his purpose. He has little interest in the amenities of his residence. In fact, he is often vocal about the rent reduction that could be accomplished without such amenities. Because of his limited time for study, he needs privacy and acoustical separation for maximum fact assimilation in the shortest possible time.

The *scholar*—the one for whom colleges were created—is actually in the minority in number. His motivation is to acquire learning; his symbol is the library. He is the only type who is oriented both to the university and ideas. The university represents the repository of knowledge, and his attachment to it is often so strong he leaves it only with difficulty. Together with the vocational student, he represents the greatest participation in graduate schools. In the residence hall environment, he represents the strongest anomaly. He is the student most sought after by academic institutions; yet he, in his academic pursuit, must adapt the most. He is the student most seeking to understand himself and everything about him. He often surrounds himself with the media of understanding; the cultural elements of art, music, and books. Yet the acoustical isolation and privacy needed for his study are often non-existent.

The *nonconformist* is the self-proclaimed "loner," "intellectual," "radical." His pursuit of knowledge goes beyond the library and history; he demands an education relevant to contemporary experience. He associates with the liberal faculty, but he is quite opposed to the college administration and does not accept residence hall norms of action and attitude. He represents a very small minority. If he is in a residence hall, it is usually because less expensive private facilities do not exist. Though his contribution to the academic community is real and valuable, it is doubtful whether he would be attracted to the residence hall, no matter what improvements be made in the future.

The interrelationship of the above groups is receiving increasing attention. Newcomb's (1961)<sup>11</sup> studies on interaction of *peer* groups and

---

<sup>11</sup> *Ibid*

peer group influence is significant. Too often, peer group influence in residence halls tends to create strong norms of social behavior at the expense of academic pursuit. Observations of conventional residence hall decoration substantiate this. Individuals will create unusual furniture arrangements or print displays. If the group approves, they are mimicked throughout the hall in short order. Considerable activity of this sort drains the available hours for study. Peer groups have been found, however, to make learning more relevant to experience. "Bull sessions" among peers provide a broadening of personality as well as an aid to assimilation of ideas.

## 2. Conventional Groupings

The conventional grouping of student housing users by age, marital status, and special requirements has evolved because of specific construction criteria established to meet the varying needs of these groups. Undergraduate/graduate status, for example, indicates more than age; it indicates an immaturity/maturity relationship of responsibility to the environment, resulting from a shifting of values and well defined wants and needs.

The ratio between male and female students is of significance in the university community. The percentage of women students in the University of California has continued to rise:

	<u>Men</u>	<u>Women</u>	<u>TOTAL</u>
<u>Academic Year, 1954-1955</u>			
Undergraduate	18,055 (61%)	11,498 (30%)	29,553 (100%)
Graduate	<u>7,384 (77%)</u>	<u>2,157 (23%)</u>	<u>9,541 (100%)</u>
	25,439	13,655	39,094
<u>Academic Year, 1964-1965</u>			
Undergraduate	28,789 (54%)	24,118 (46%)	52,907 (100%)
Graduate	<u>19,674 (76%)</u>	<u>6,286 (24%)</u>	<u>25,960 (100%)</u>
	48,463	30,404	78,867

The accommodation of women and men in any housing system raises many implications. "Intervisitation" of the sexes in student housing must be weighed—both for its academic value as well as its social concern. Intervisitation must not be accomplished at the expense of privacy, since the area of privacy appears to be the most maligned of the student's sensibilities in institutional housing.

Undergraduate

The impact of a university on the freshman student has received



considerable attention from groups such as the Center for Research and Development in Higher Education. Undoubtedly the impact varies tremendously according to the background and personality of the individual. The adjustment to the university world is the most difficult for the nonacademically oriented student whose background did not imply the possibility of college and least difficult for the student for whom a university education was inevitable.

A chance to experiment awaits the freshman as he enters a life free from the regulation that he had at home. He has a need for security which he attempts to satisfy by socializing and gathering a group of friends.

Outside pressure upon the freshman often comes from those parents who expect the university to act *in loco parentis*. This expectation apparently arises from the recognition that academic maturity may precede social maturity, and these parents expect the university to provide sound supervision of the student's social life. To try to do so compromises the university's freedom in adapting its policies to those students desiring freedom to develop themselves. Resentment is shown by the number of students who leave university housing after their first year.

The more mature a student becomes, the more self-directed he is, the less socializing he feels impelled to take part in, and the more annoying residence hall regulations become. As many present residence halls are largely incapable of responding to changing student attitudes, students look elsewhere for accommodations.

Paradoxically, the freshman is the most lonely of university students and requires much privacy. This privacy is not to be confused with that required by the graduate student. It is not the minimizing of interruptions of study, but rather the solitude and quiet necessary for self-examination.

It has been noted that the only truly private space in most existing residence halls is the toilet stall. In these days of sustained public faces, this seems most unfortunate. Young people, in the trying-on period of life, often need a private mirror before which they can either laugh or cry.

The affluence of postwar American society reinforces the student's need for privacy. The prewar student was likely to come from a large family in a small house, but his postwar counterpart comes from a small family in a large house. He, therefore, is accustomed to a degree of privacy unexpected by earlier generations. Then, too, the more affluent student brings more paraphernalia—electric typewriter, radio, record player, TV, popcorn popper, coffee percolator, tape recorder, and even refrigerator—to school with him. As he becomes more involved in study, academic trappings are added to the list. His volume of personal effects

may exceed the storage capacity,<sup>12</sup> provided by the design of the residence hall.

Finally, being a late adolescent, the freshman is likely to be more energetic than responsible—which often accounts for student destruction of residential buildings. Areas and finishes capable of permitting energy release together with rooms which permit such creative expression as wall decorations would remove some of the burden of conformity and the malaise of frustration. Personal identity with one's living space is a psychological need and source of stability and security.

A freshman can forgive an environment that lacks privacy and solitude, for his emphasis is on understanding his fellows and the comparative freedom of his new life. As his academic emphasis sharpens, however, his tolerance for constant adjustment shortens. Table 2 shows the progressive decrease in occupancies of university residence halls by students after the freshman year.

#### Graduate

The University of California, in accordance with the direction of the Master Plan for Higher Education, is undergoing a shift of emphasis from undergraduate to graduate studies. In 1945-55, the graduate program was only 23 percent of the enrollment. A decade later, in 1964-65, the graduate program had increased to 31 percent. It is projected to exceed 50 percent in the next decade.

The graduate student with his maturity and orientation has moved into the adult world. University peer groups rarely include both graduate and undergraduate members since the graduate student is most impatient with the frivolity of his juniors. His isolation differs from that of the undergraduate student in that he considers as a disadvantage anything that reduces his opportunity to devote the greatest time and effort to his studies.

Visits to the various campuses disclosed more tendency for upper classmen than graduate students to desire apartments. For the latter, apartment living, with its cooking, entertaining, and cleaning, places a lien on time already considered insufficient for study. The graduate student seems to desire either a single room and smaller bath in a suite with shared study and social spaces, or an on-campus apartment preferably without a kitchen but with nonscheduled, central dining and limited game and recreation possibilities. In all of the studies of graduate student environment reviewed, privacy and acoustical isolation were most in demand. The crucial need is for better illumination, more bookshelves and larger desks than are normally provided the undergraduate. Because of the lack of these, graduate occupancy rates in residence halls are minimal. The total study environment is most important.

---

<sup>12</sup>University of California, University Residential Building Systems Publication No. 4, *Storage Study*, October, 1967.

**TABLE 2**  
**PERCENTAGE OF UNDERGRADUATE RESPONDENTS**  
**LIVING IN UNIVERSITY RESIDENCE HALLS**  
**1963-1964 ACADEMIC YEAR<sup>a</sup>**

Academic Standing	Berkeley	Los Angeles	Davis	Riverside	Santa Barbara
<b>Men</b>					
Freshmen	34.8%	29.4%	91.9%	79.7%	81.4%
Sophomores	25.9	22.9	44.6	42.4	37.9
Juniors	18.6	15.9	35.2	27.4	37.5
Seniors	11.2	12.0	12.3	9.8	17.8
<b>Women</b>					
Freshmen	53.0	48.2	84.7	84.0	37.0 <sup>b</sup>
Sophomores	39.7	29.6	74.1	59.7	63.4
Juniors	26.1	22.2	46.6	32.2	35.4
Seniors	11.9	14.6	12.7	14.7	11.5
<b>All Undergraduates</b>					
Men	21.4	20.2	51.0	43.6	50.8
Women	32.9	29.7	63.9	58.0	40.0
<b>TOTAL</b>	26.5	24.9	58.1	50.7	44.9

<sup>a</sup>Real Estate Research Corporation, *Analysis Student Housing Market and Alternate University Housing Programs, 1963-1975*. Prepared for: The Board of Regents, University of California, Berkeley, California, January 1965.

<sup>b</sup>Thirty-six percent of women freshmen live in University apartments so total population in University housing is 73%.

Older and more mature students generally will not move into buildings where they are required to contract for both room and board. However, if the opportunity is provided them to obtain meals elsewhere or to prepare simple food for themselves, they are far more likely to accept university housing.

As the graduate student becomes more predominant in the university's enrollment, a plan must be found to create new housing and to convert the old in ways which better meet his needs.

#### Married

The married students are rapidly becoming a significant group on campus. In 1963, married students accounted for 5.9 percent of the undergraduate and 17.1 percent of the graduate students at the University of California. In 10 percent of the marriages, both spouses were students. This group is expected to increase significantly.



Married students are more vocationally oriented, serious, and concerned about cost than are other groups of students. The housing presently provided for them is usually either former military facilities, hastily converted after World War II to enable veterans to return to college, or consists of more recently constructed facilities of similar quality. This housing, although comparatively inexpensive, does not produce an environment conducive to academic achievement. Poor acoustical qualities, for example, place rather serious adaptability requirements on married students who are having a difficult time adapting to each other in the struggle to further their education. This difficulty is emphasized if one of the partners is not a student, and even more so when there are children involved.

In this situation, trying to find a private, peaceful place for study becomes an effort in wishful thinking. When the bedroom is used for study, the living room must often accommodate TV, children, guests, or all three.

Study spaces away from the home are considered acceptable only if within a very short walking distance, and even then represent a physical separation of the family that is often not acceptable.

Cost, as a criteria, cannot be ignored in housing for married students, for to do so would deprive many deserving students of their education. Apartment rent of \$90 to \$100 per month represents a large portion of a teaching assistant's \$290 per month total income. This cost is of even greater importance to students with children.

Most of the wives committed to supporting their husbands or to raising the children must defer their academic interests, and thus they fall behind their husbands. Cooperative child care activities provided by the University or the students themselves can sometimes enable a student wife to continue her studies. In any case, her welfare dramatically affects her student husband's psyche and progress. All kinds of facilities that decrease the isolation impact and student/nonstudent conflict within the married student residence complex should be considered.

#### Commuter

The commuter is largely excluded from the social and informal academic life of the university. The most readily offered solution is commuter participation in the activities of the residence halls. Others consider the presence of student unions and commons as wholly adequate. The efficiency of either solution is, of course, dependent upon both the commuter's attitude and the emphasis given to academic and cultural activities in the residential facilities. At Berkeley and Los Angeles so many students live in private housing that residence halls are not the centers of activity as they are at the campuses more isolated from cities. The commuters of Riverside and Davis differ significantly in background and motivation from the commuters of Berkeley and Los Angeles.

Also, if university housing reflects too high a level of affluence, the commuter is reluctant to participate in its activities. If, on the other hand, university housing represents an inexpensive housing solution and for some reason becomes the center of action, commuters will be in full attendance.

Because peer group involvement is relevant to academic experience, the commuter must be given facilities which provide for spontaneous discussion. Recreation spaces are not satisfactory in that they are programmed for nonacademic activities. Eating places are presently the most acceptable facilities, as shown by the amount of discussion taking place at campus snack shops.

Another possibility might be to introduce space so commuters can study within the student housing project. A double occupancy room could become a space for four commuter-study carrels. The commuter could take some of his meals in the dining room and participate in more spontaneous activities generated in the housing unit while he slept elsewhere.

In addition, as libraries are equipped with electronic retrieval ability, the availability of information in student housing will require only the expense of distribution and terminals. A listening-study station in the housing unit may well become more valuable than a seat in the library. The availability of the station to the commuter would increase his participation in the totality of academic activity, and the opportunity for participation in other activities would be a desirable by-product.

#### Foreign Student

The more students from other countries take part in residence hall life, the greater will be their value to other students. There should be opportunities for the preparation of special native foods for all students. Participation in such activities can be a very effective social force, as well as a source of enjoyment. Foreign students should be encouraged to furnish and decorate their rooms with the artifacts of their homelands. Not only does this add to the comfort, but rooms then become interesting "museums with resident curators and guides."

The foreign undergraduate student is perhaps more akin to the American graduate student in his attitude toward social and academic life. Although foreign students often like the idea of apartment living, and indeed often choose apartments rather than campus housing, this loses much of the value of having foreign students on the campus. Suite arrangements in campus housing might allow them to maintain small group entities in more private activities and to mix with the other students in social activities.

#### Physically Handicapped

Handicapped students form a small but important group on any

campus. They must be accommodated in ways which are appropriate to their handicaps.

Usually the university provides facilities on each campus so that a physical handicap need not prohibit admission. In the case of student housing, rooms must be on the ground floor with access that is either direct or by ramps or on upper floors with elevators. There are special door sizes so wheelchairs can be easily moved around and suitable assist bars mounted in proper relation to all physical facilities. Bathrooms and bedrooms must be fitted with appropriate accessories, as recommended by the American Standards Association.<sup>13</sup> The increasing use of electronic communication will greatly assist the handicapped student when terminals are located in his housing unit.

## B. FACULTY IN RESIDENCE HALLS

Faculty participation in student housing programs is increasing—particularly at Santa Cruz and San Diego. Recognition of the demands of academic pursuit, together with the realization that much learning occurs outside of the formal classroom, impels the University to encourage informal contact between faculty and students. Campus housing complexes designed to accommodate discussion groups enhance the opportunity for spontaneous as well as more formal discussion. Spaces for discussions should resemble living rooms, thus reducing a portion of the learning facilities to a more human scale.

Santa Cruz and San Diego are attempting to include a faculty member in the campus housing unit. Called a Preceptor, he is somewhat in the tradition of the Master of the English house—a combination faculty advisor, house mother, and encourager of spontaneous academic discussion. He is provided an apartment with entrances leading to the student residence and to the exterior. In this way, there is direct student access when the preceptor wishes involvement together with complete privacy and acoustical separation for the preceptor which are significant requirements for the success of this concept.

## C. THE ADMINISTRATION'S ROLE IN STUDENT HOUSING

As a user of the residence hall, the administrator has been primarily "keeper of the inn" and, secondly, a parent or location. The building may have full administrative services similar to hotels, or it may be limited to accommodations of supervisory personnel. The hotel functions can include telephone switchboards, call desks, mail service, food handling service, linen supply, janitor and maid service, storage control, recreation direction, and sundry supplies. Personnel accommodations vary between resident assistants' use of student rooms to apartments or detached homes for resident supervisors (house mothers).

The tendency appears, primarily for economical reasons, to diminish services in residence halls and, thus, service personnel and their escalating wages.

<sup>13</sup> American Standard Association. *American Standard Specification for Making Buildings Accessible to and Usable by the Physically Handicapped*. New York: American Standards Association.

Examples are the Centrex telephone system, eliminating telephone switchboards, and the smaller bath which reduces maid service. Suite arrangements with students responsible for keeping their own area clean are another.

The continuing need of supervisory personnel has been answered on some campuses by filling the positions on a part-time basis with faculty members, thus furthering the academic integration. Administrative functions generally are grouped with other campus administrative functions in central office facilities. Centralization of services is more apparent in installations of increasing size. Linen and students' off-season storage, mail service, and food handling are increasingly grouped together to minimize costs. Some service provisions continue to be located in individual residence halls. These include custodial equipment, linen supply, and trash collection.

The role of *in loco parentis* is receiving increasing attention by University officials. It will probably continue to be a factor in residence hall occupancy to some degree. Some residence supervision, with its environmental support, will be a continuing requirement particularly for undergraduates.

Regulations at the University of California vary from campus to campus, from tight control to an almost complete absence of special rules. The building system can and will be developed so that any rules engendered by it are minimal. For example, a building with quiet corridors, although bearing heavy traffic, will not require regulation and policing.

Rules relating to intervisitation and behavior are, obviously, in a different category from those mentioned above. However, they are somewhat influenced by the physical facilities. For instance, the trend toward relaxation of regulations concerning use of student rooms for coeducational visiting presents a need for accommodations which appear more like living rooms.

## VI. HIERARCHIES OF SPACE

The preceding definition of "users" directed attention to the relationship of these "users" with their physical environment—the residence hall. The literature research disclosed excellent material describing residence halls in the language of architects and excellent physiological data such as light, temperature, humidity, and acoustical levels conducive to various human activities. However, psychological data available in the simultaneous observation of residence hall activity and space was minimal.

Consequently, reliance was placed on the acceptable tools of architecture for environmental evaluation—empiricism and intuition. The observations and conclusions presented here came from the University of California as well as universities and colleges throughout the country. The occupants and their activities relative to the environment have been catalogued as follows:

### ACTIVITY

Study/Sleep  
Bathing  
Eating  
Socializing  
Recreation  
Academic/Cultural  
Service  
Circulation

### SPACE

Student Room  
Bathroom  
Dining Room  
Living Room  
Games Room  
Classroom/Library  
Storage/Service Rooms  
Corridors and Stairs

As this catalog of activities and spaces is an assumed one, related to the University's experience and vocabulary, it suffers from generalization. It obviously includes overlap and divergence. Also, the relationships presented above cannot account for possible changes in activities; these and other qualifications of data presented are discussed in Section VII-B. Change (p. 61).

The most surprising observation from the survey was the sameness of residence halls throughout the entire country. Apparently those responsible for the conception and design of university housing generally held the same preconceived notion of what constitutes a good residence hall. Typically found was a multi-storied building with double-loaded corridors, double occupancy rooms, extensive built-in furnishings, finishes that do not permit student adornment, and gang baths. The result presented a rigidly consistent institutional quality.

Furthermore, privacy and quiet are rarely available to the tenants. It is known that the complete lack of privacy in penal institutions can lead to mental instability. Multiple occupancy student rooms substantially reduce privacy.

This basic need of man to be alone with himself was more acutely understood in the past. The English ritual of "sporting the oak" clearly shows concern for this need. Rooms in the older English colleges had two doors, with the outer one being made of heavy oak. When the student closed this oak door it



indicated an absolute desire not to be disturbed, and the closed double doors also gave excellent acoustic insulation.

Freshmen and sophomore students are more apt to put up with the disturbances of noise and lack of privacy, but upper classmen and graduate students will seek solutions in private housing.

In summary, the resulting edifices left no doubt as to the participation of (1) the housing administrator in obtaining low maintenance materials and easy control and (2) the Federal lending authority in the insistence on built-in furnishings.

The user influence is in evidence only in a negative manner—the student response to this environment is shown by acts of destruction. Not in evidence are the other users of the residence hall—the faculty responsible for encouraging and promoting the total academic environment.

The survey showed that existing facilities do provide high-quality materials and a high level of shelter and custodial services. They rarely, however, provide academic or cultural inspiration; thus they are somewhat in conflict with the purpose of a university. The increasing concern for academic accommodation in the residence halls was found on all campuses to be too often stymied by the physical limitations of the housing.

In the following sections, environmental solutions to the problem of activities are suggested.

**A. STUDENT ROOMS (Appendix IV, p 99 for Furnishings)  
(Appendix V, p 107 for Configurations)**

The student room is the smallest element and the basic space in the housing facility. It is the core environment of the student who spends many of his waking hours here (undergraduate girls eight hours, boys six hours). In this space the student studies, sleeps, dresses, and socializes. He stores all of his clothes, books, and personal possessions here except for nonseasonal clothing and larger size sports equipment. In a very real sense, it is here that his identity within the university is established since it is the only space on campus which he himself can control in any way.

**I. Study**

Individual study is accomplished within an amazing spectrum of activities. It takes place while standing, walking, sitting, lying, singing, whistling, eating, drinking—alone or with another person. Few participate in group studying.

People study at different rates. Some subject themselves to long periods of monk-like concentration; others apply themselves for relatively short periods interspersed with intervals of social or recreational activity. The individual prefers to study in his own room and, for intense study, by himself. For this type of study, the roommate must be elsewhere.

The desk apparently is used for reading only in cases requiring extensive note-taking or use of several reference sources. Otherwise, it is a repository for study and personal equipment including typewriters, calculators, drafting equipment, radios, and phonographs. Yet it does not have the height accommodations or acoustical padding needed to use these materials quietly and effectively. Its length is inadequate for any use--the 42-inch standard desk is overtaxed with books and writing material simultaneously with personal paraphernalia. The space requirements for multiple references, collation of materials, or large belongings create overflow onto the bed or floor. Consequently, work is often done on the floor of the room, particularly if it is carpeted, and on the bed.

Sometimes an apparent student idiosyncrasy has a real functional basis. Many students are observed typing on the floor when an adequate table was available. The students then demonstrated the acoustical, drum-like sound of the unmuffled typewriter which conflicted with their roommate's sleeping. Students often use the corridors and bathrooms as study spaces when typing and study rooms were missing or occupied and roommates were sleeping.

Bookshelves are generally inadequate in size and length. Moreover, the shelves are usually in places of difficult access and are poorly illuminated. There is a need for more shelves, preferably adjustable and flexible as to placement.

Built-in furnishings are resented because their rigidity impedes both individual living and study habits. Students are forced to supplement the university furnishings with such things as orange crates to create an individual study environment. The results may appear cluttered to some but accommodate the occupant. Clearly then, a book, pen, reading light, straight back chair, and a 42-inch-long desk constitute less than the optimum answer to the study problem.

The telephone is a most important tool to the student. Its use is restricted only by the university's ability to provide an individual instrument and the student's ability to pay the toll. The telephone is finding increased use--both as a study as well as a social aid.

The tremendous and continuing advances of the electronics industry are only beginning to be noted in the educational sector. The experiment at Santa Cruz could be expanded by information retrieval systems in text libraries and extensive distribution of input and read-out consoles from existing computer centers. Although the student of today is required to attend unilateral communication lectures in large halls, the student of tomorrow may view the lecture on TV in his room, coming out for seminars or laboratory sessions. Future student housing must accommodate this.

Each of the University of California campuses is connected by telephone tie-lines, but tomorrow's expansion into computer, information

retrieval and audio-visual TV will enlarge the sphere of communications. The students of all campuses could simultaneously be able to receive the lecture of one outstanding professor or professional team. Much of this communication will be at the discretion of the student. It is but one indication of the growing importance of the student room as a study aid. Only the provision of conduit access is needed to expand the horizons of the student room beyond imagination.

## 2. Sleep

The student's pattern of activity is rarely consistent; he may sleep at any time of the day or night. Two occupants of a room very rarely follow the same schedule. Exams and social activities modify their patterns even more extensively. It is the varying patterns that present conflicts in multiple occupancy rooms. Interesting improvisations—hanging blankets, relocated wardrobes and beds, and stacked dressers—were observed in situations where one student wished to study while the other slept. Perhaps beds with suitable acoustical and light separation screens could be one answer; single occupancy rooms would be better.

Present provisions for sleeping range from the studio bed in single rooms to bunkable beds in multi-occupancy rooms. Beds acquired a decade ago are increasingly limiting to the succeeding generations of taller students. As previously noted, reading is more often done in the comparatively relaxed attitude of the bed or easy chair. However, the bed is seldom designed to provide the slight slope for proper sitting; some adjustment therefore is necessary. Beds could be made to resemble couches and have a mechanism allowing a shift from sloping for sitting to level for sleeping position.

## 3. Socializing

The student's room has always attracted social discourse. With more liberal rules, the student's room becomes more of a social center for both sexes. The student room, however, with its split emphasis of study-sleep presents difficulties as a social environment. The bed is the chief offender. The bed as a bed conjures all sorts of social problems in intervisitation. A bed with cushions or pillows tossed about is not acceptable because of the difficulty of sitting upright comfortably. Its conversion to a sofa, with its contributions as a living room furnishing, is most desirable—not to mention its more comfortable use for multiple seating.

Clothes and storage of personal possessions are also a bedroom symbol. Closets look like closets; dressers look like dressers. Contemporary furniture designers, however, have provided storage units for studio apartments quite acceptable as living room pieces. Such pieces have yet to make their appearance in student rooms. It should be possible to have either intimate conversations or sessions with a number of



additional individuals within one's own private room. The bed, hard and soft chairs, and even a desktop may all be brought into use as sitting surfaces to accommodate a congenial group. The space should be such that furniture can be quickly arranged to make group conversation easy.

#### 4. Dressing

The concentration of clothes storage in the student room not only precludes its use as a social environment but also restricts its use for dressing. The storage shortages are discussed in more detail in a separate volume.<sup>14</sup> That study discloses that the normal four-foot closet and five-drawer dresser just satisfies the male student, and it provides only half of the female student's storage requirements. The referenced Storage Study shows that both sexes require differing volumes and types of storage. Smaller combination storage units might well accommodate student preference and allow flexibility of room arrangement.

### B. TYPES OF SPACES

#### 1. Single Rooms

The single room provides controlled privacy for its occupant with respect to all other students. It may open directly to a corridor, and thus provide complete privacy coming and going, or it may be part of a suite or apartment. Privacy for sleeping can be controlled, presuming adequate,<sup>15</sup> acoustic separation between adjacent spaces is provided.

The single room should be arranged suitably so that it is possible to study effectively with an invited second person. In addition, the student should be able to play the radio, phonograph, tape recorder, or quiet instruments, and indulge in reasonable recreational activity without creating an acoustical problem for his neighbors.

Because of the pressure of social conformity, it is undesirable to occupy a single room if there are only one or two on a floor of doubles. Since this is the experience with singles on University of California campuses, it cannot be taken as a valid test of single room arrangements.

One authority<sup>16</sup> believes the single room is "unlikely to be really humanely satisfactory if it is less than 120 square feet. The furniture should be movable, not fixed, to allow the student to organize his own environment."

---

<sup>14</sup>University of California, University Residential Building Systems Publication No. 4, *Storage Study*, October, 1967.

<sup>15</sup>A precise statement for terms such as "adequate" appears in *Contract Documents and Performance Specifications*, University of California, URBS Publication No. 1, June 1967.

<sup>16</sup>Richard Dober, *The New Campus in Britain Ideas of Cosequence for the United States* New York: Educational Facilities Laboratories, Inc., p. 11.

## 2. Split-Double Rooms

The split-double room provides the social contact obtained by two students sharing a common space, but, at the same time, recognizes and solves the problem of conflict of interest in the student's social and study activities. The split-double room consists of two spaces with a connecting opening. When connected with a door, there is a degree of acoustic privacy. Without a door, the arrangement provides only visual privacy and shielding from illumination sources. The provision of two spaces makes it possible for one student to sleep while the other studies or talks with friends.

The best arrangement would permit the students to treat each of the two spaces as a single room with direct communication between them. Then the spaces may be separated on an activity basis, with the desks, study, and living facilities in one space and sleeping and dressing facilities in the other. When one of the two spaces is large and the other small in size, the students live together much as they would within a traditional double room. Where the habits of two students come into conflict, the second smaller space can relieve the situation. For example, the second room can provide for a late hour study station. This type of arrangement will not necessarily suffice to provide the appropriate separation between social and sleeping habits, but may do so if the smaller space has sufficient room for an extra chair.

If two students must share space, the split-double represents an optimum arrangement, because easy choice exists for privacy or sociability.

Here again, the space with the two beds should have the atmosphere of a sitting room so that one is not consciously in a bedroom.

## 3. Double Rooms

The double room is the present standard in student housing, largely because of the tradition and economies it presumably brings to initial construction costs. This economy is deceptive, however. Since these rooms irritate their inhabitants because of lack of privacy and quiet, and because of insufficient study and storage space, it becomes necessary to provide typing rooms, individual study carrels, and large public lounges (furniture showrooms). These factors should be considered when citing the economies of the standard double room residence hall, as shown in Table 3.

At present, the area of a double room varies between 145 to 250 square feet. Within these areas, possibilities for alternate furniture layouts and room shapes are particularly important. Some room configurations make possible the separation of the two students in their study activities; other situate the desks in parallel arrangements for study. The use of movable wardrobes to shield the beds from desks provides the degree of

separation between activities within a room but reduces the apparent size of the room. Wardrobes which are grouped to provide dressing alcoves or to line corridors remove valuable space from the room itself.

**TABLE 3**  
**COMPARATIVE STUDY OF AREA REQUIREMENTS**  
**(16 Students in Single and Double Rooms)<sup>a</sup>**

	Square Feet		
	Singles	Doubles	Difference
Space per student in student room	110	95	15
Space in 16-student grouping when typing room and study room are provided for each 16 students in the double room layout, plus a larger lounge, gross, excluding food services	195	190.6	4.4

<sup>a</sup>University of Guelph. *Student Housing Study*, Evan H. Walker, Student Housing Consultant, November 1965, Appendix 1, Comparison of Single and Double Rooms, p. 105.

Examples of this type of room arrangement exist at Michigan State and the University of Michigan, as shown in Plate 2. These arrangements strongly suggest that movable wardrobes be utilized to allow room modifications.

A better example of the double room is shown on Plate 3. Herein, the occupants have greater opportunity to move free-standing furniture to suit their preferences.

If double rooms are to be provided, there should be sufficient area to be used as split-double, single, or other types of room in the future. *More than enough conventional double facilities already exist on most campuses.*

#### 4. Triple Room

This form has been popular with some students on a small number of campuses. Where this arrangement has been used with movable furniture, the extra area provided in the single space has made possible a large number of different space arrangements. The resulting individuality of the layout of the room would appear to be a major reason for the popularity of such spaces, since some students do seem to prefer a three-student to a two-student room. The triple room, however, tends to breed more serious interpersonal problems.

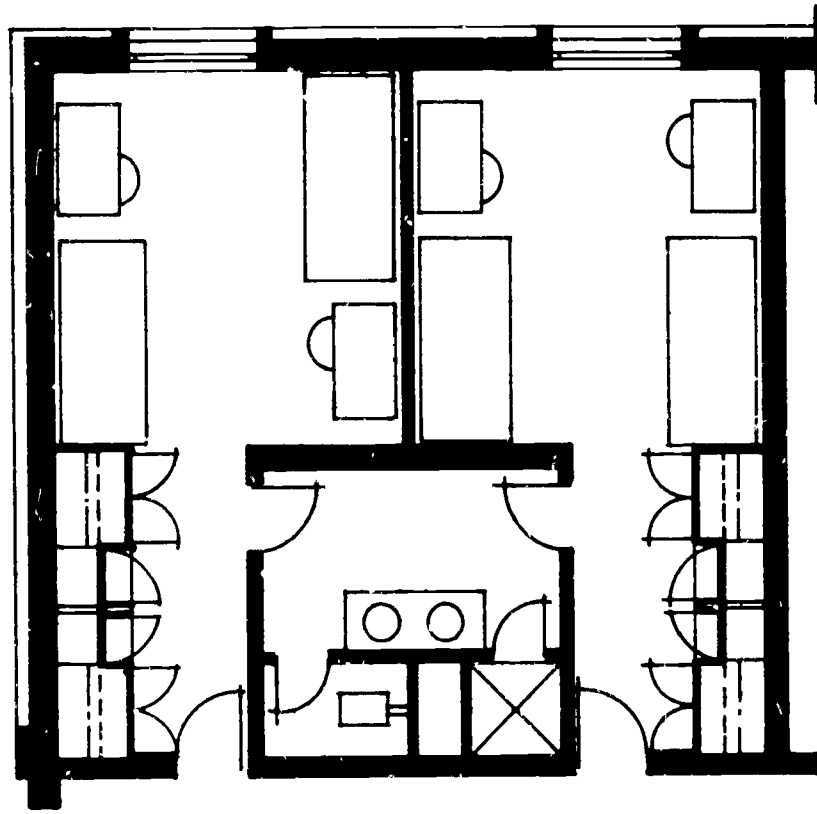

*BUILT-IN CLOSETS AT ENTRY TO DOUBLE ROOM.  
THE STUDY-BEDROOM SPACE BECOMES MINIMAL.*



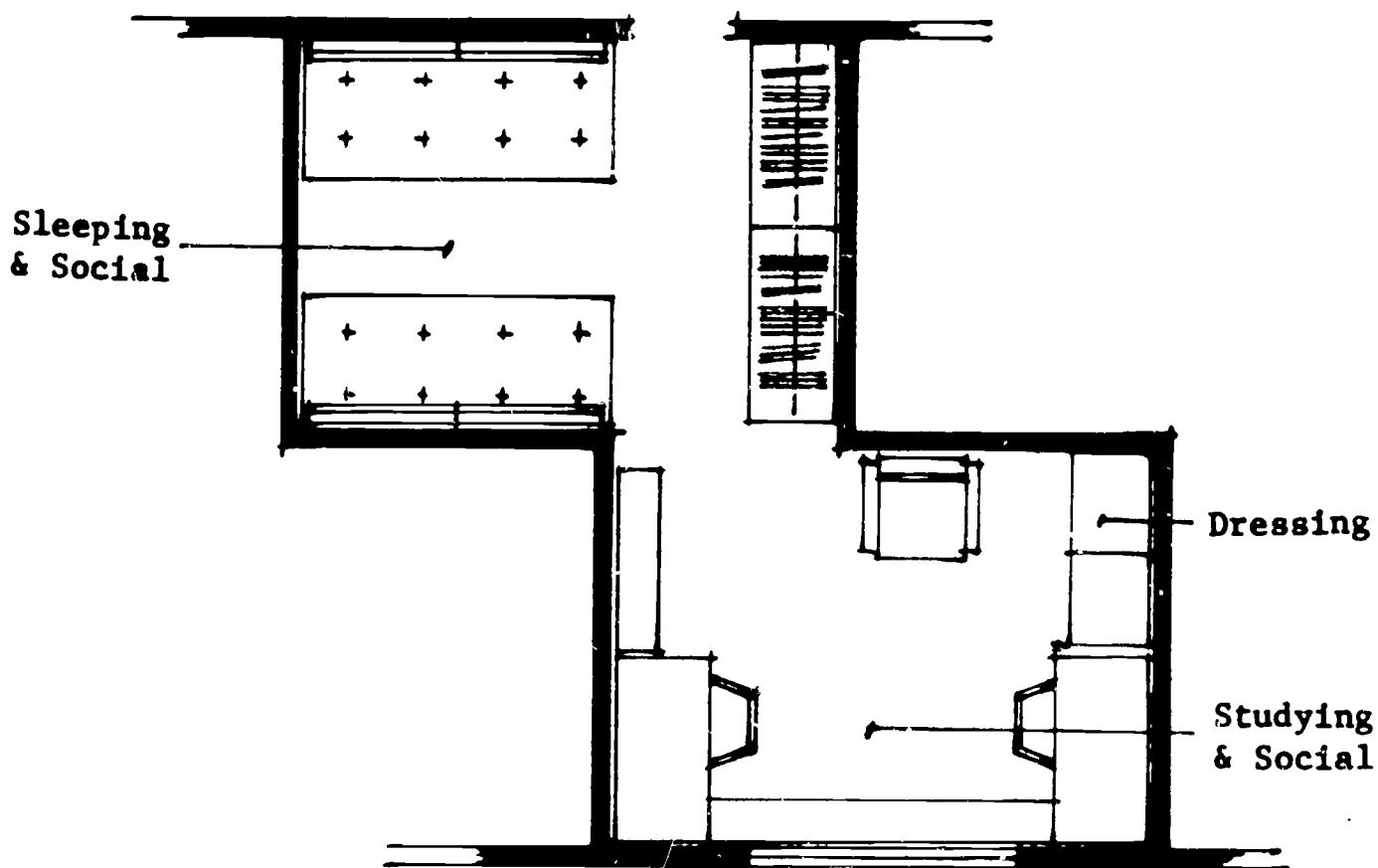
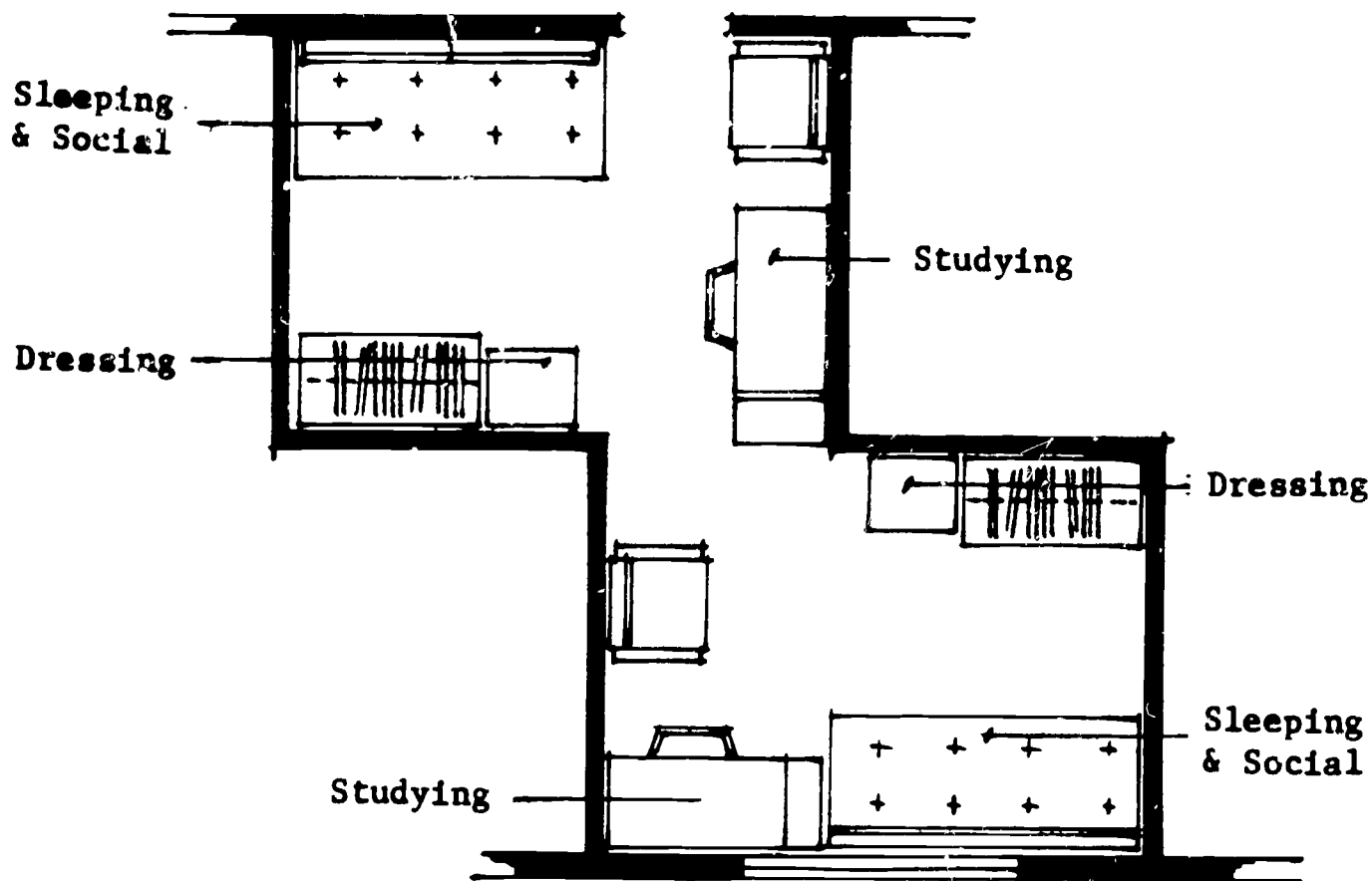

## 5. Four-Student Room

Four students sharing one room have the same problems as the students sharing double or triple occupancy rooms. There is a slight advantage in that the space is usually large enough to be subdivided by wardrobes, lightweight partitions and other elements. Some versions of this type were seen at a number of campuses—for example, the new fraternity houses at Stanford University and the trailers used in an emergency at the Santa Cruz campus.

Although few students would choose to live in a single space with three other strangers, four friends might choose to be together and succeed at it **IF PROVIDED** sufficient options for the disposition of the space and for the appropriate screening of different activities (Plate 4). The Santa Cruz trailers, because of their diminutive size, lack of separation, and fragile quality, were not considered successful for a permanent solution, although satisfactory for emergency use.

Large numbers of students may share a space, but more than four require that separate adjacent spaces be provided for conflicting activities. At this point, one must consider the suite plan.

## 6. Suites

A suite is an arrangement in which four or more students share the total space in single and double rooms, with or without a bathroom, and at least one extra common space. In this way, the group of students working and living together have at least one space under their own control which may be used for any of the three major facets of room life: sleep, study, or social activities (see Plate 4). "The major value of the suite plan is the opportunity it affords for closer student association and the freedom it gives students using the various spaces as they wish."<sup>17</sup> The common space within a suite (1) reduces some of the pressures felt by two students trying to share a single room; (2) provides for social activities as does a residential living room, and (3) includes in social activities those students who might not have direct or easy association with other students.

The sharing of a fair amount of space by a group of students makes possible a variety of usage patterns and provides considerable flexibility in room rearrangement so the space may be organized in the best possible way. (Plates 5 and 6).

Typical patterns are a common room also used as a study room; one room used only for sleeping, with separate rooms for study and social purposes; and four single rooms, or two double rooms, with a common living room.

Suites composed of single rooms, rather than double rooms, increase the

---

<sup>17</sup>Harold C. Riker and Frank G. Lopez. *College Students Live Here: A Study of College Housing*. New York: Educational Facilities Laboratories, Inc., 1961, p. 14.

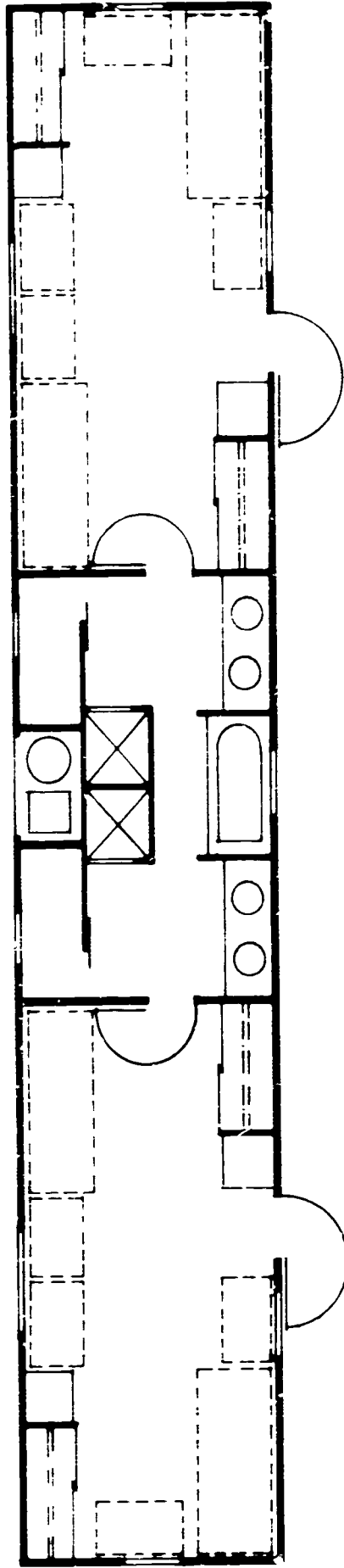

TYPICAL TRAILER PLAN, 8 STUDENTS.  
UNIVERSITY OF CALIFORNIA, SANTA CRUZ.

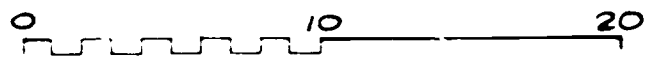

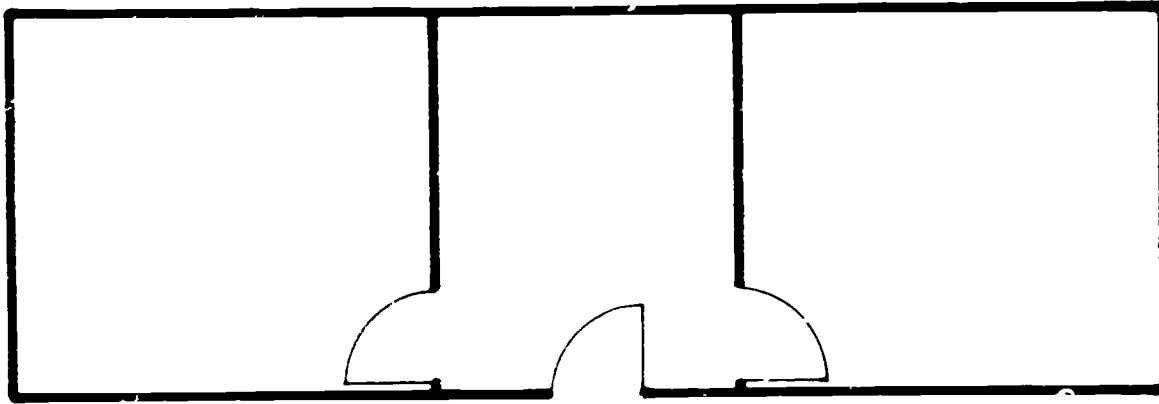

**a** COMMON LIVING ROOM, TWO DOUBLE ROOMS.

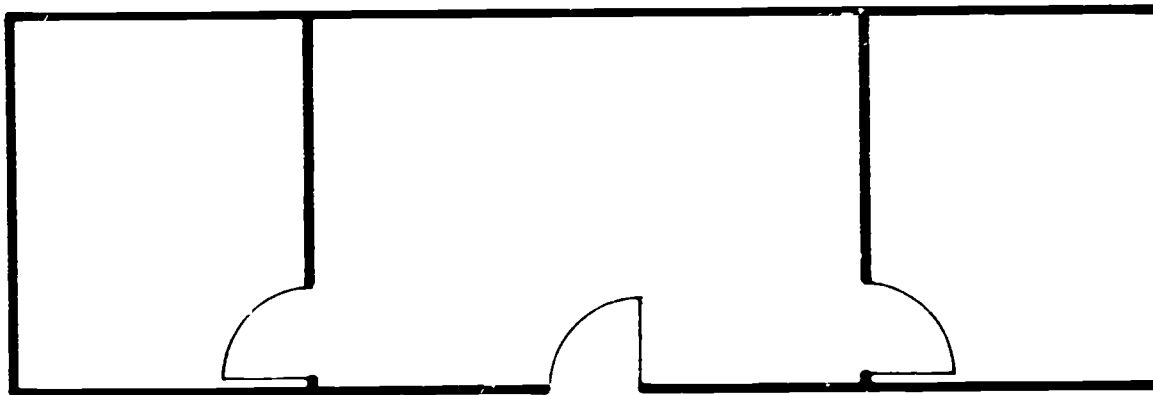

**b** COMBINED SOCIAL AND STUDY ROOMS,  
SEPARATE SLEEPING.

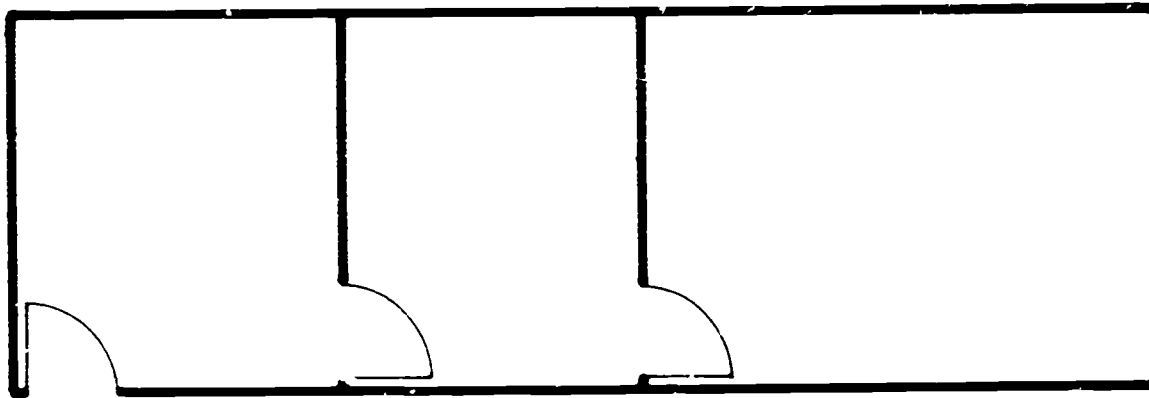

**c** SEPARATE ROOMS FOR STUDY, SLEEPING,  
AND SOCIAL.

SUITE ORGANIZATION I



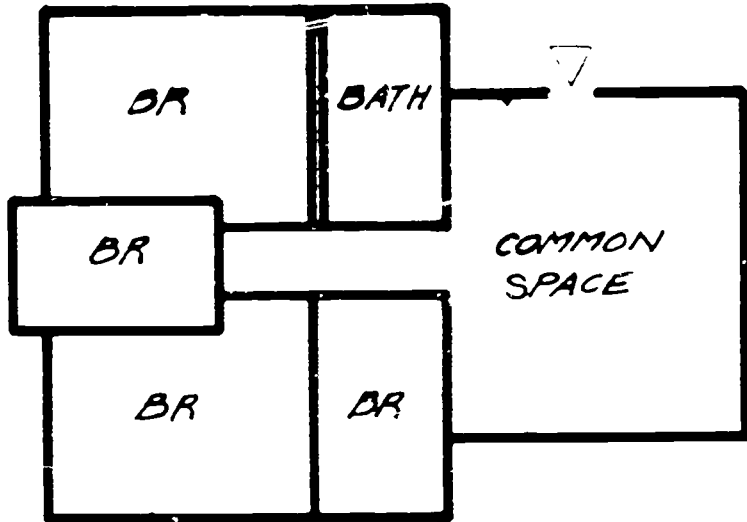

**a** ACCESS TO STUDENT ROOMS THROUGH COMMON SPACE.

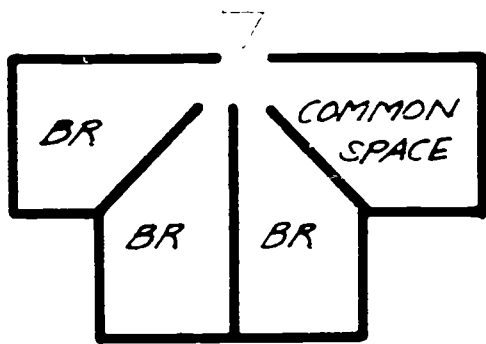

**b** SEPARATE ACCESS TO STUDENT ROOMS AND COMMON SPACE.

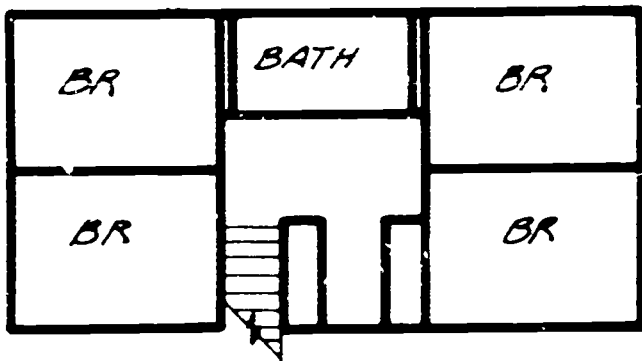

**c** STUDENT ROOMS ON DIFFERENT LEVEL FROM COMMON SPACE.

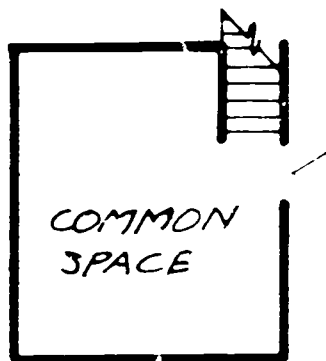

SUITE ORGANIZATION 2

potential for privacy. However, if one desires a separate room for each student, additional square footage above that normally required for four students will be necessary. This space can be regained through a reduction in the large lounge spaces on the ground floor (see Section VI.E.3. "Recreation and Social Activity").

Another way to obtain sufficient area for a suite is to incorporate some corridor space in the common room. Corridors may not be necessary for a four-student suite; therefore, this approach works best when perhaps eight or ten students share a suite. A major problem in optimum use of the common room of a suite concerns doors that do not provide sufficient acoustical separation between the common room and the individual's room. In such a case, spaces for study outside the suite become necessary.

Bathroom facilities pose one of the major questions in the design of suites: should these facilities be available just for the suite, or for a larger group of students? Although initially it is less expensive to build gang facilities for larger groups, long term economy can be obtained by providing residential-scale bathrooms for suites wherein students, instead of maids, clean the facility. The reduction in maintenance requirements will more than amortize the increased first cost of smaller bath facilities, while also considerably improving the human quality of the housing environment for the student.

Suites must also be considered for the social impact resulting from them. Students developing a strong social life around the activities of their suite may have less incentive to make friends outside their circle. Objections might be posed for this reason, especially in regard to freshman students who desire maximum opportunities to meet fellow students.

Another problem in suites composed of four to seven students is the possibility that strong friendship patterns may have a detrimental influence on a student's academic life. The peer group pressure to go out for coffee or a hamburger is quite strong on one out of six. Riesman notes this "encapsulation." One size of an encapsulated group has been equated with the six occupants of an automobile.<sup>18</sup> Therefore, the organization of space into suites must be such that the students in different suites may interrelate. If, for example, three suites of six students share a larger living room so that a group of eighteen have something in common, it is quite unlikely that a small group desiring a coffee break could interrupt the study pattern of the other eleven. More likely, they will find only one or two others willing to go along.

The shared living room also provides a larger base for friends and tends to reduce stress. The value of grouping students into a suite where an ordered pattern of relationships may develop (first with a roommate or perhaps with two or four additional students and then with a larger

---

<sup>18</sup>Ronald K. Boyer *The Student Peer Group: Its Effect on College Performance*. Ph.D. Thesis, 1965. Case Institute of Technology

number) provides some balance in the way outside attachments are formed. Such relationships are not well studied at this time and the patterns of change in the future may be very considerable. *Therefore an approach to the use of suites should leave open the maximum number of options for future living patterns.*

Within the suite it is important to organize the common spaces so that privacy is maintained between the sleeping rooms and the bathroom. Problems occur where the common room(s) in a suite may be open for coed activities and it is necessary to pass through the common area when going between one's room and bathroom.

With eight or more students in double rooms, more than one common space in a suite is required. At least one separate study, as well as a social room, should be provided to accommodate privacy for study and typing late at night and the noisy social sessions that inevitably occur within a suite (see Plate 7). Obviously, single rooms designed so that privacy may be maintained represent the most ideal solution.

If the suite is entered through a common space, this space is useful only for purposes where quiet and privacy are not essential. Attempts to provide a combined living-study room in the suite are not successful, because students soon revert to using their bedrooms for study. (Suites at the Albany campus of State University of New York illustrate this point.) The suite telephone must not interfere with study activities.

## 7. Apartments

An apartment differs from the suite in providing a kitchen. It may consist of single or double rooms built around common spaces as in a suite, or it may have a number of students in a sleeping room with the other spaces in common for social dining, and study purposes.

A consensus of opinion among students indicates that three to five single students form an optimum group for apartment living. This number tends to work well in arranging cooking chores for the week, with weekends left on an individual basis. With more than five students, assignment of cooking chores becomes difficult. Indiana University and Michigan State University (Plate 8) have extremely popular facilities accommodating four students.

Some students believe they get better food at less cost if they do their own cooking and shopping. Therefore, the apartment requires adequate food supply capacity to handle a week's supply of groceries. The apartment's dining area must be of a size to permit the occupants to have dinner guests.

Experience indicates that most students living in apartments tire of the responsibility of cooking and cleaning. It would seem appropriate to develop central food service to relieve apartment groups of the cooking

PLATE 7

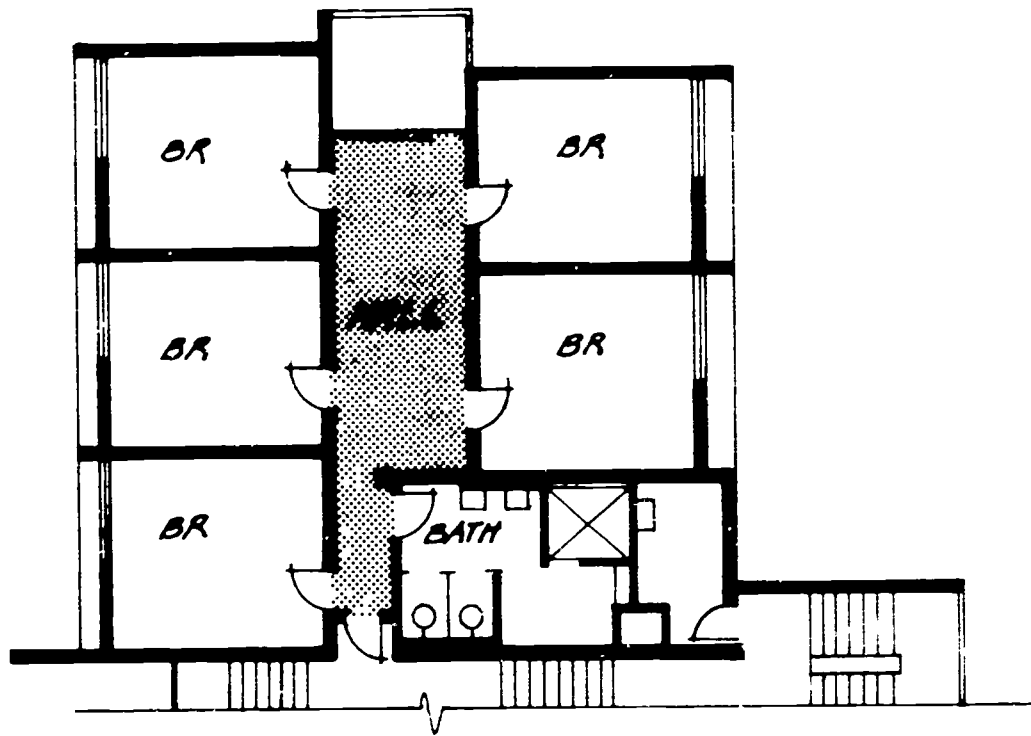

SUITE OF FIVE DOUBLE ROOMS AROUND COMMON SPACE. NOISE IN COMMON SPACE DISTURBS ROOMS: AND COED USE OF HALL MEANS STUDENT MUST DRESS PROPERLY TO GO TO BATHROOM.



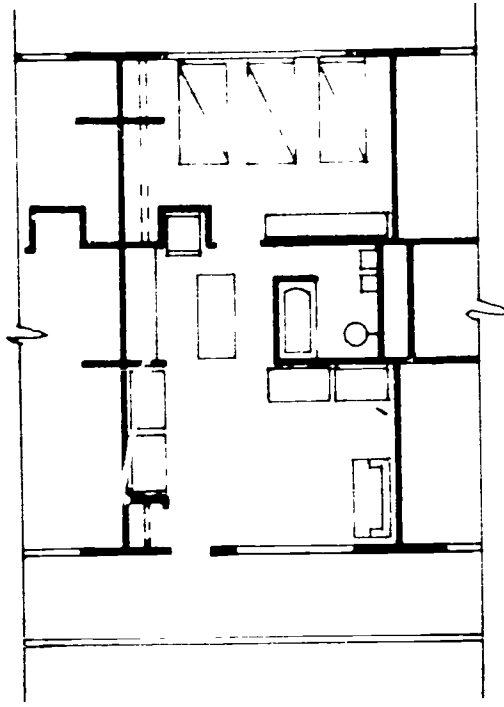

**a.** MICHIGAN STATE UNIVERSITY

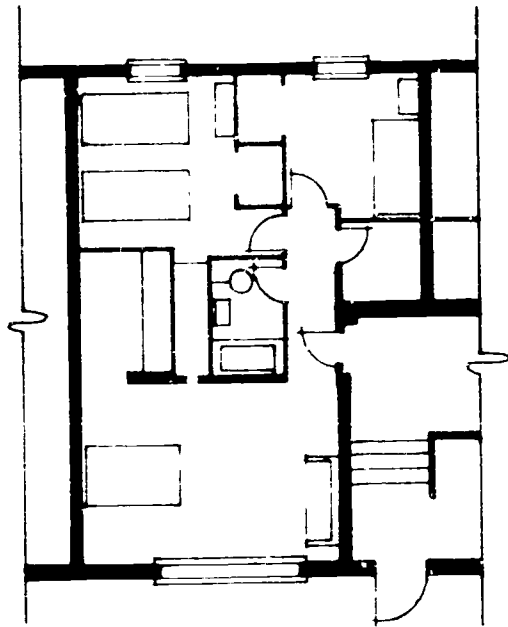

**b.** INDIANA UNIVERSITY

FOUR-STUDENT APARTMENTS.



chores, while still retaining the benefits of apartment-type living.

For example, Indiana University has two living groups of sixty students having common kitchen facilities with another residence hall which provides the food service of the small living unit. Trolleys containing food for sixty students are wheeled from the central kitchen to the serving kitchen within the living units. All services and cleanup are then handled by the living units at a very considerable savings in cost. These two facilities are the most popular ones on the entire campus (Plate 9).

Much of the attraction of the apartment is its comparative freedom from behavioral control, particularly in regard to coeducational activities. This does not mean complete relinquishment of responsibility on the part of the university, but rather the more positive recognition of the student's adult qualities.

Students living in apartments tend to develop a very close relationship with those sharing the space. It is a pattern perhaps more appropriate for upper division and graduate students than it is for lower division students. These students have developed a range of acquaintances on a campus and now are interested in cultivating specific friendships. Apartments, like suites, can be grouped to provide activities through combined use of spaces for recreation, study, and social affairs so that a wide range of friendship is possible.

Since the key difference between the suite and the apartment is the kitchen, provision should be included in suites for a plug-in kitchenette so that conversion from suite to apartment may be accomplished quickly. This will enhance flexibility of use during the summer sessions for conferences involving families or for foreign students.

## C. SPACE ALLOCATION

### 1. Dimensions of Student Rooms

Rooms of minimum size cause many complaints from students; this was reflected in both the URBS and another recent study.<sup>19</sup> The situation has changed a great deal in the past twenty-five years. Stern Hall at Berkeley was built in 1940 and allowed 480 gross square feet per student with 250 square feet in the student room. Present rooms of 85-95 square feet per student create serious problems of constriction.

Built-in furnishings compound this problem by preventing an expressive control by students of the layout of their rooms. Movable furniture, in most instances, would not alleviate the problem because the small room size dictates only one possible arrangement. The need for expression is so important to the student that he sometimes resorts to an irrational layout, such as placing the bed across the door opening, in an effort to control his environment.

<sup>19</sup>Real Estate Research Corporation. *Analysis Student Housing Market and Alternate University Housing Programs*. 1963-1975. Prepared for The Board of Regents, University of California, Berkeley, California, January 1965.

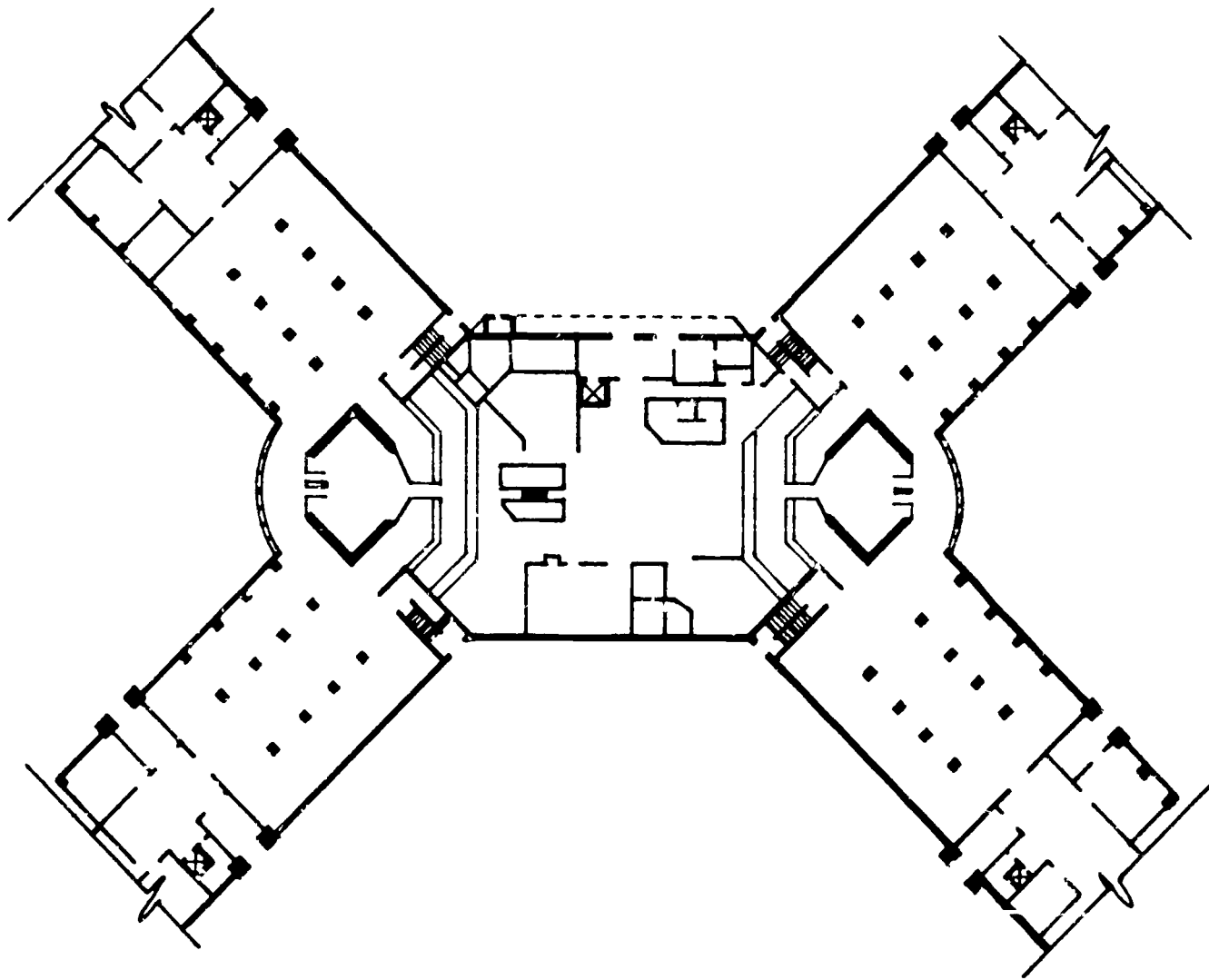
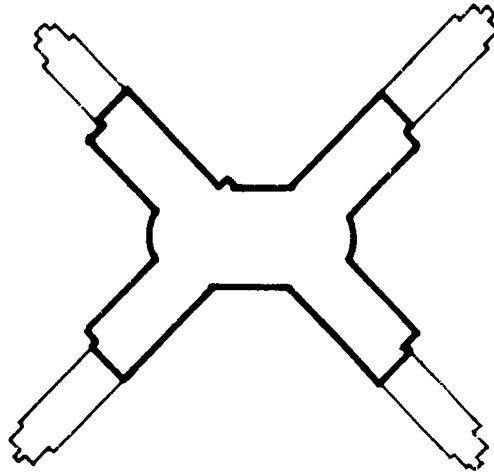

*GROUP OF DINING ROOMS SERVED BY ONE KITCHEN,  
INDIANA UNIVERSITY.*

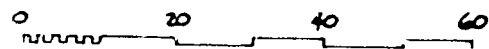



The allocation of space will be the decision of the campus. Adequate space allocation within the student room must have first priority so that enough space is provided to allow both immediate individual expression by the student and future arrangement by the university. Henry Wriston, who spent a lifetime as a college president, says in his memoirs:<sup>20</sup>

If I had been able to find money enough, every dormitory I had anything to do with would have been made up of single rooms—no doubles, much less rooms for three or four. Single rooms constitute no danger that undergraduates will not learn how to live with other people. Their lives are much too gregarious; even if they have one room where privacy is possible they will still have enough group experience to avoid becoming anti-social.

Several studies (see Table 4), have recommended that a single student room of rectangular shape contain 100 to 115 square feet. The rationale for this recommendation is:

A room must contain enough space to provide the student with (1) the furniture he needs, (2) space for the use and service of this furniture (make beds or open drawers), and (3) possibility of a variety of furniture layouts.

The final size of URBS furnishings will be determined during the development of the Performance Specifications. Sizes common to the University, however, were used for initial studies. The dimensions<sup>21</sup> act as a basis for an initial approximation of room sizes, allowing optimum different furniture arrangements.

The attached dimensional study (Plate 10) is based on a bed of 7 feet in length, desks of 3 feet 6 inches in length and 5 feet in length, and a 5-foot wardrobe, assuming that drawer storage is in the wardrobe. Use spaces are also shown. Thus the room width should be from 8 feet to 8 feet 6 inches if the maximum number of combinations of furniture and use space are provided within a room. This dimension provides for any of the following combinations:

a bed plus its use space,  
a bed and passage,  
a wardrobe plus a door,  
a desk plus a door,  
the bed with its width (rather than length) plus a door,  
the bed with its width plus a desk,

---

<sup>20</sup>Henry Wriston. *Academic Procession*. New York, 1959. p. 12.

<sup>21</sup>Sizes of URBS furnishings vary so slightly from initial assumptions that dimensions hereinafter used are valid.



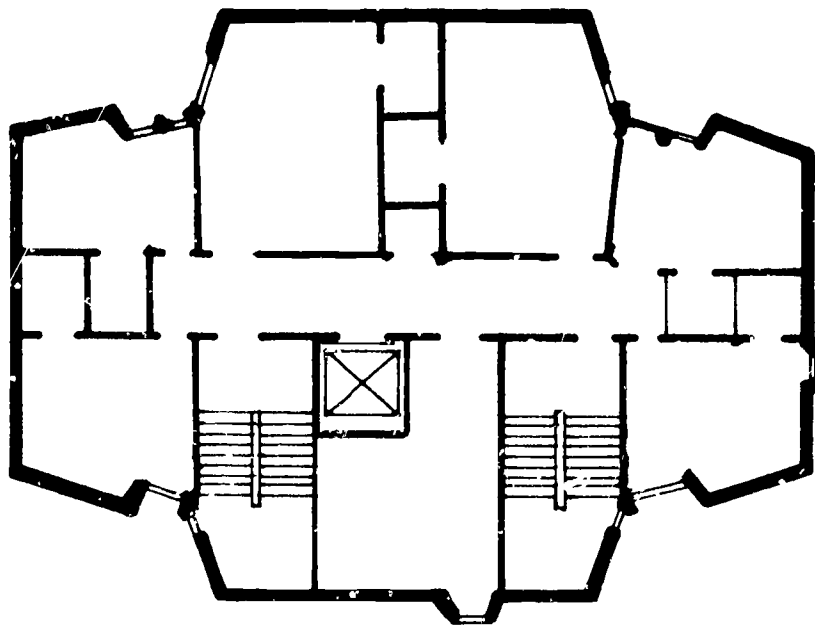

**a** STILES COLLEGE, YALE. TOWER FLOOR PLAN.

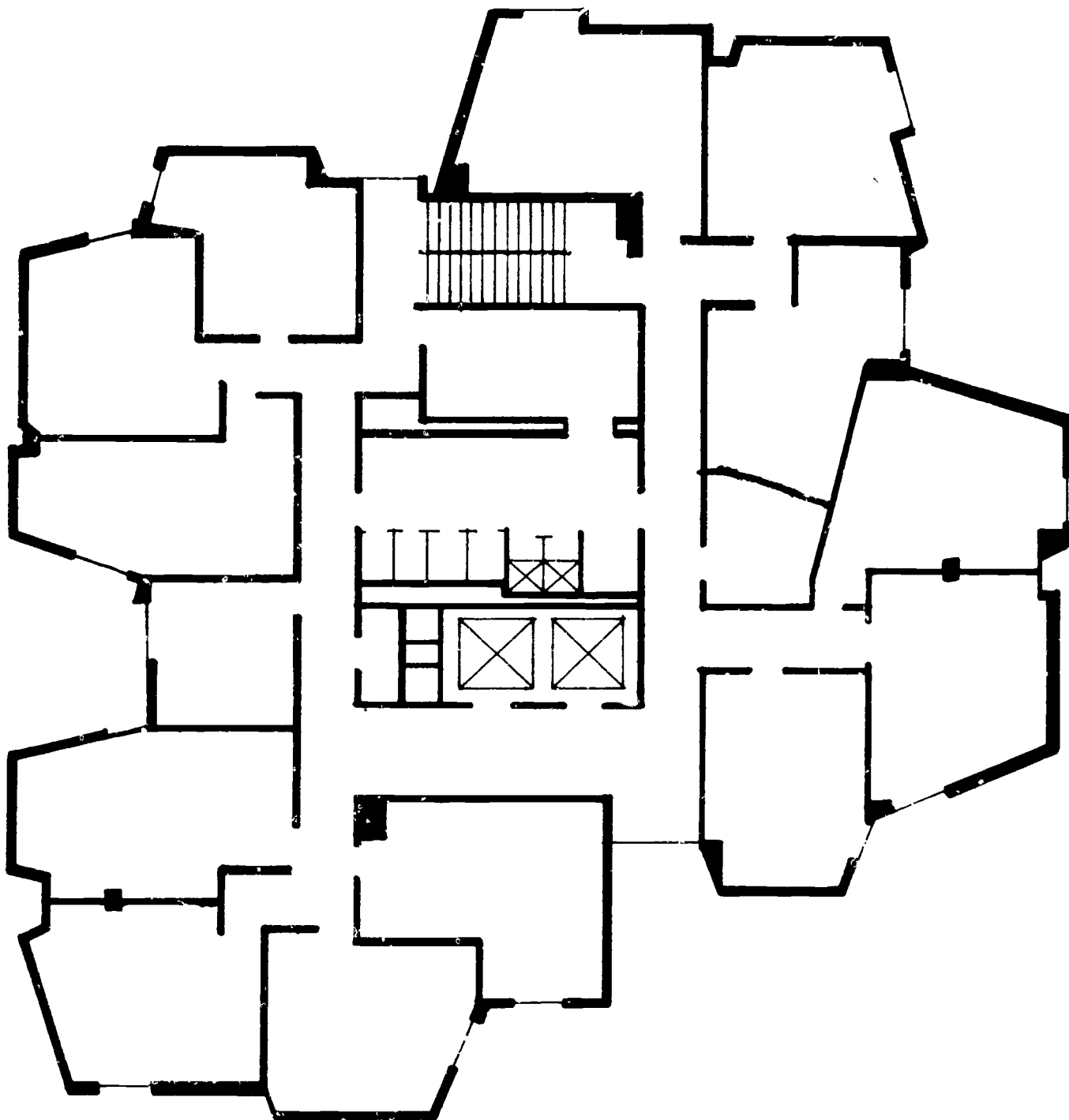

**b** ST. OLAF'S COLLEGE, MINNESOTA

the bed with its width plus a wardrobe,  
 a bed plus desk, and  
 a wardrobe length plus desk length.

The ability to provide use spaces not conflicting with furniture is the governing factor for room depth. This depth is 13 feet 6 inches or an area of 114.75 square feet. From this, minimum and maximum figures may be established.

Appendices IV and V show the derivation of these sizes in more detail as well as the recommendations for double room sizes.

**TABLE 4**  
**RECOMMENDED SPACE STANDARDS PER STUDENT**  
**FROM A GROUP OF RECENT STUDIES**

University	ASF <sup>a</sup>		OGSF <sup>b</sup>	
	Single	Double	No Dining	With Dining
University of California <sup>c</sup>	100	100	239	265
California State Colleges <sup>d</sup>	94-110.5	84-91	215.5	230.5
University of Guelph <sup>e</sup>	115	NR	230	
University of Pennsylvania <sup>f</sup>	108	NR	271.5	290
M.I.T. <sup>g</sup>	140		470	486
Aggregate United States: <sup>h</sup>				
Men		96.7	211.1	234.7
Women		103.5	237.4	261.4

<sup>a</sup> Assignable Square Feet per student.

<sup>b</sup> Outside Gross Square Feet per student.

<sup>c</sup> University of California. UC Standing Committee on Residence Halls, Meeting of August 29 and 30, 1966, Hilton Inn, San Francisco International Airport.

<sup>d</sup> *Development Guide for Campus Housing, California State Colleges*, July 1968, Table 1, Summary of Project Norms, p. 13.

<sup>e</sup> University of Guelph. *Student Housing Study*, Evan H. Walker, Student Housing Consultant, November 1965, pp. 56-66.

<sup>f</sup> University of Pennsylvania. *Study of Undergraduate Men's Housing System*, Geddes, Brecher, Qualls and Cunningham, Architectural Consultants.

<sup>g</sup> Massachusetts Institute of Technology. *A Program for Undergraduate Men's Housing*, MIT Planning Office, August 1965.

<sup>h</sup> Eugene E. Higgins, M. Louise Steward, and Linda Wright. *Residence Hall Planning Aids*, Report OE-51004-9A, *College and University Physical Facility Series*, Department of Health, Education and Welfare, U. S. Office of Education, Washington, D. C.

Width	Depth	Assignable Area	Suggested Rating
8'	11'-6"	92	minimum
8'	12'-6"	100	minimum – optimum
8'	13'-6"	108	optimum
8'	14'-6"	116	optimum – generous

The specific design of interiors, or the use of irregular room shapes, may change the basis of standards expressed above (Plate 10). Each campus will make its own decisions as to the amount of square footage that can be allocated to a single room; then the optimum size of a double room (to accommodate future change) should be twice that of the single room. Suites and apartments should be developed accordingly. A four-student suite would be the size of four single rooms plus the common use space.

The establishment of the space standards for student rooms must be coupled with the total area allowed per student. The area is based on the estimated construction cost per square foot together with the construction budget. When the areas for total square footage and square foot per student room are fixed, a breakdown of the space use for other facilities can then be determined. Appendix I shows existing University of California residence halls analyzed on this basis.

## 2. Volume and Form

The third dimension in relation to the floor area is volume, and economy dictates that space is not wasted. In this sense, any space not appreciated by the occupants can be regarded as waste. Thus, a minimum depth between the floor and the ceiling below is of great significance; space paid for here is not usable. At the same time, the building and its services must function properly, and space reduction in the wrong place may increase the cost in installation and maintenance of services.

Buildings which have skylights, clerestory lighting, and sloping ceilings elicit an appealing response from the students due to the resulting individualized living spaces. These particular features are difficult to incorporate on intermediate floors without great cost, but certainly they can be utilized on the top floors.

Non-rectilinear rooms are appealing and desirable if designed in relation to furniture arrangements. While the URBS system will be basically rectilinear in character, limited non-rectilinear arrangements may be possible within the major spaces. Some very successful non-rectilinear rooms have been built, notably at St. Olaf's, Northfield, Minnesota, and

the Stiles and Morse Halls at Yale University (see Plate 10). Unfortunately, non-rectilinear geometrics cannot be generally accepted as appropriate for an economical building, as most of our standard materials and components are organized on a rectangular basis.

## D. ENVIRONMENT

### 1. Thermal

Student rooms require an appropriate thermal environment for the functions carried on within them. The environment is affected by temperature ventilation, humidity, radiation, and the quality of air produced by filtration.

As the campuses of the University of California offer a summer quarter, there will be a greater need for mechanical cooling at some campuses. Mechanical cooling at Riverside and Davis is a necessity, and it would be desirable at most of the other campuses. At Berkeley, Santa Cruz, and San Francisco, a pleasant thermal environment may be obtained without mechanical cooling, depending upon the building's configuration.

The thermal system in student housing allows for individual requirements and the wide range of conditions which personal preference may demand. In a mixed community of smokers and nonsmokers, it is important that the air be kept moving and clean, particularly in student rooms, interior spaces, lounges, and study areas. Because of variations in student hygiene, separate ventilation of individual spaces is required, especially in the more athletic mens halls. The odors in many residence halls were found by visitors to be "overpowering."

Although conventional air conditioning is more economical within a sealed space, it is important that students be able to open their windows to enjoy the soft, fresh morning and evening air and in the lower height buildings to enjoy communication (but not access) through an open window.

### 2. Lighting

The quality of lighting in student rooms is determined by the quantity and brightness of both the light sources and their general surroundings. High illumination levels are appropriate to study; lower levels to social functions. In the daytime, natural daylight may provide much of the necessary illumination, if windows are well placed and the glare eliminated. However, high illumination levels are necessary in areas where concentrated study is to be done, but the brightness contrast between the work and its surroundings must be at a minimum.

Lighting sources in student rooms should be integrated with the movable furnishings. This tends to minimize maintenance and fix the

light's proper level. Light for reading in bed, including a reading light for a bunk bed, is necessary. Because of the highly individualized nature of activities performed in student rooms, light from a number of well-placed, but relocatable, point sources is far more useful than light from one central source.

### 3. Acoustics

"Quiet" is the most desired characteristic of any living arrangement in the opinion of students, so acoustical considerations are of great importance. Fundamental to providing quiet environments are walls, floors, windows, and doors providing adequate reduction of sound from adjacent activities. The URBS system will use a large number of demountable partitions, so economical acoustical design will be the largest technical problem. Doors do not facilitate noise reduction. Since standard doors are poor in acoustic performance and high-performance doors are too expensive for student housing use, a solution isolating noise at low cost will have to be developed. The best inhibitor of noise is good planning of the relationships between rooms. Wherever possible, social areas should be isolated from student rooms by at least two doors.

### 4. Color, Texture, Materials

Materials presently used are hard, unyielding, and chosen for their durability and ease of maintenance. However, those used invariably lead to a depressing, sterile, institutional appearance.

The student's need for expression and the university's need for ease of maintenance need not conflict. Walls can be covered with safe, removable wall-covering panels that provide the student with unrestricted freedom of color and decoration. At the same time, these wall coverings can still protect the underlying materials to the university's satisfaction. It should be possible for the student to roll up his wall coverings at the conclusion of use and use them again elsewhere if desired.

Such panels would allow women students to compensate for the universal institutional aspect of student housing by softening the environment through the use of feminine colors, textures, and materials.

It was observed that in rooms with hard walls, pinup materials are often fastened to the softer acoustical tile ceilings. Resawn wood wall panels, however, would permit unrestricted tacking up of decorations.

It was noted that carpeted residence halls are far more quiet and that the behavior of the student was more adult. Since many study and social activities are performed on the floor, the comfort and quiet provided by carpeting is quite desirable.

## 5. Appliances

A revolution in the design, production, and marketing of economical personal appliances has been occurring in recent years. As a result, the number of electrical appliances brought by the student to college invariably exceeds the number anticipated by the designers of present-day residence halls. Consequently, this has precipitated problems of general safety, fire hazards, intolerable odor, noise levels, and frequent interruption of electrical services.

Another significant new trend is in the personalization of entertainment and cultural media; tape recorders, radios, phonographs, and miniature TV sets are within the economic reach of most students. The transistor radio permits the student to listen to the world beyond the campus even as he walks from one class to another. Similarly, the personal, transistorized TV is making the TV room out of date, just when most residence halls are specifically providing such space.

Hot plates, coffee pots, and popcorn poppers are sources of potential fire hazards and odors. At the minimal level of food service, there is need for facilities enabling students to make their own coffee. This requires but an appropriate surface and an outlet, with the student providing the appliance. At the next level is a desire for cold drink storage facilities. Students will sometimes buy old refrigerators—often hazardous and awkward in size and arrangement. The idea of partitioned refrigerators, as in English residence halls where students may keep track of their own belongings, would seem to be a good solution. The minimal cooking done on a hot plate introduces the need for clean-up facilities. The sink becomes necessary; the problem becomes one of the minimal kitchen facility—a project expensive enough to require careful consideration of how many students it is going to serve. Where such kitchens are provided, in addition to full food service facilities, they must inevitably be few and far between. Women are far more interested than men in such a facility.

Television, radios, tape recorders, stereos, movie projectors, and phonographs create disturbing noises for others. These require, in most buildings, extensive and expensive noise abatement policing. The better solution to the problem of appliance noise, previously mentioned, is good planning for adequate isolation between rooms.

Most of all, new buildings must recognize the evolution of electrical use by providing initial high capacity with provision for easily adding to that capacity with minimum disruption.

## E. FACILITIES

### 1. Bathing

The gang bath is one of the most persistent features of residence halls.



It has been defended on the basis of economy and its contribution to socialization (Plate 11).

Certainly, the initial construction cost of one central gang bath is less than that of smaller installations in several locations. It is also evident that when a bathroom serves more than a few students, maintenance becomes nobody's business but the university's; the student does not realize that he is paying extra for the university's maintenance of the gang bathroom. The initial extra expense for smaller baths will actually result in long-term cost savings if the students themselves maintain the smaller bathroom, because it eliminates the need for maid service throughout the life of the building.

Another economic factor against the gang bath is its inflexibility. Residence halls with gang baths are far less appropriate for participants in conventions, reunions, and institutes where families or both sexes are involved, than are areas with smaller baths serving a few persons.

## 2. Dining

There is universal agreement that the single, large rooms for hundreds of students is not the satisfactory solution to the problem of student-dining facilities. Although the large kitchen with its extensive equipment, service line arrangements, and building area is the most economical and efficient method of food preparation, the one large dining room for all students negates a congenial atmosphere for social interaction during mealtime.

Dining facilities that combine the best advantage of the large kitchen—efficiency, economy, and flexibility—while at the same time provide a pleasant and social dining environment can be built. Proper planning permits large central areas to be divided by movable walls into smaller or intimate dining rooms. The walls can be moved when a large scale is needed for social events such as dances, etc. (Plate 12).

Food preparation in student rooms presents a safety and sanitary problem, but the need for between-meal snacks can be solved independently of the central dining room. Students can be accommodated by automatic vending machines located at strategic points in the residence hall or by provision of facilities in which they can prepare snacks themselves. (See Appliances, VI.D.5.) Student food preparation problems cannot be solved by unenforceable prohibitions but only by construction of appropriate areas with automatic cooking devices and controlled food storage facilities.

## 3. Recreation and Social Activity

Assimilation into the student society is the foremost concern of most new students.<sup>22</sup> Recreational spaces and facilities are important in

---

<sup>22</sup>Marvin B. Freedman. "The Passage Through College," *Journal of Social Issues*. 1965.

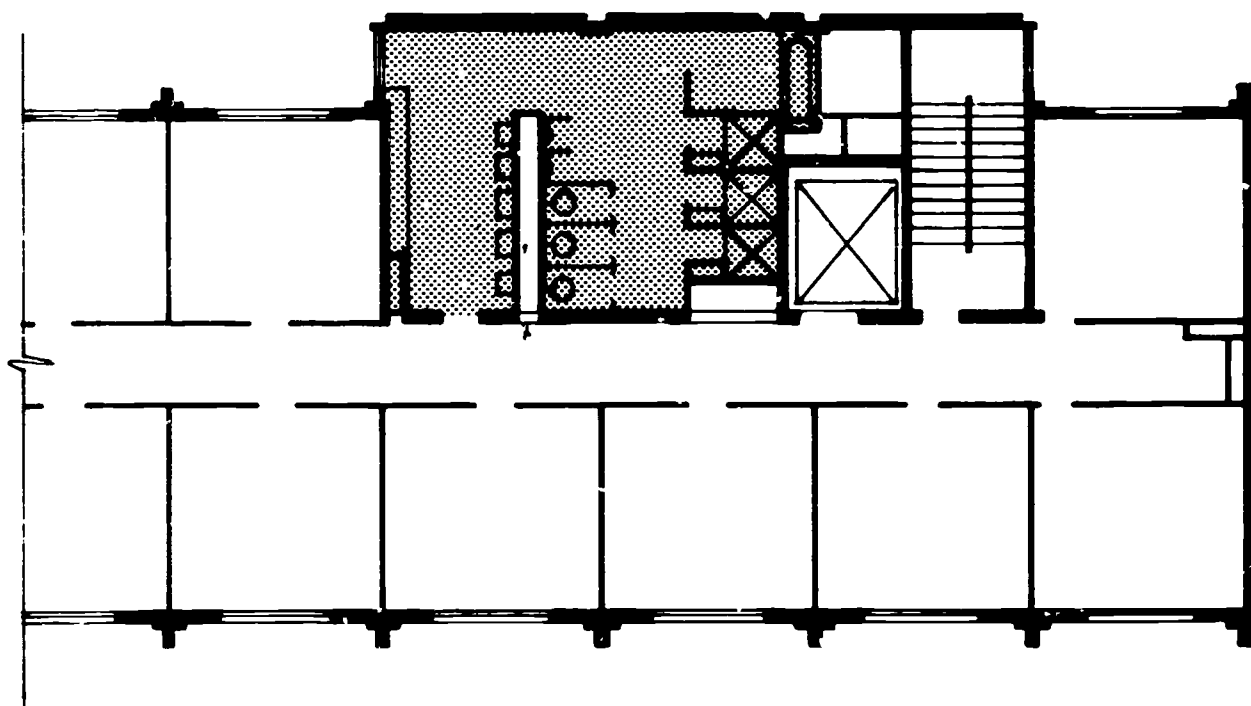
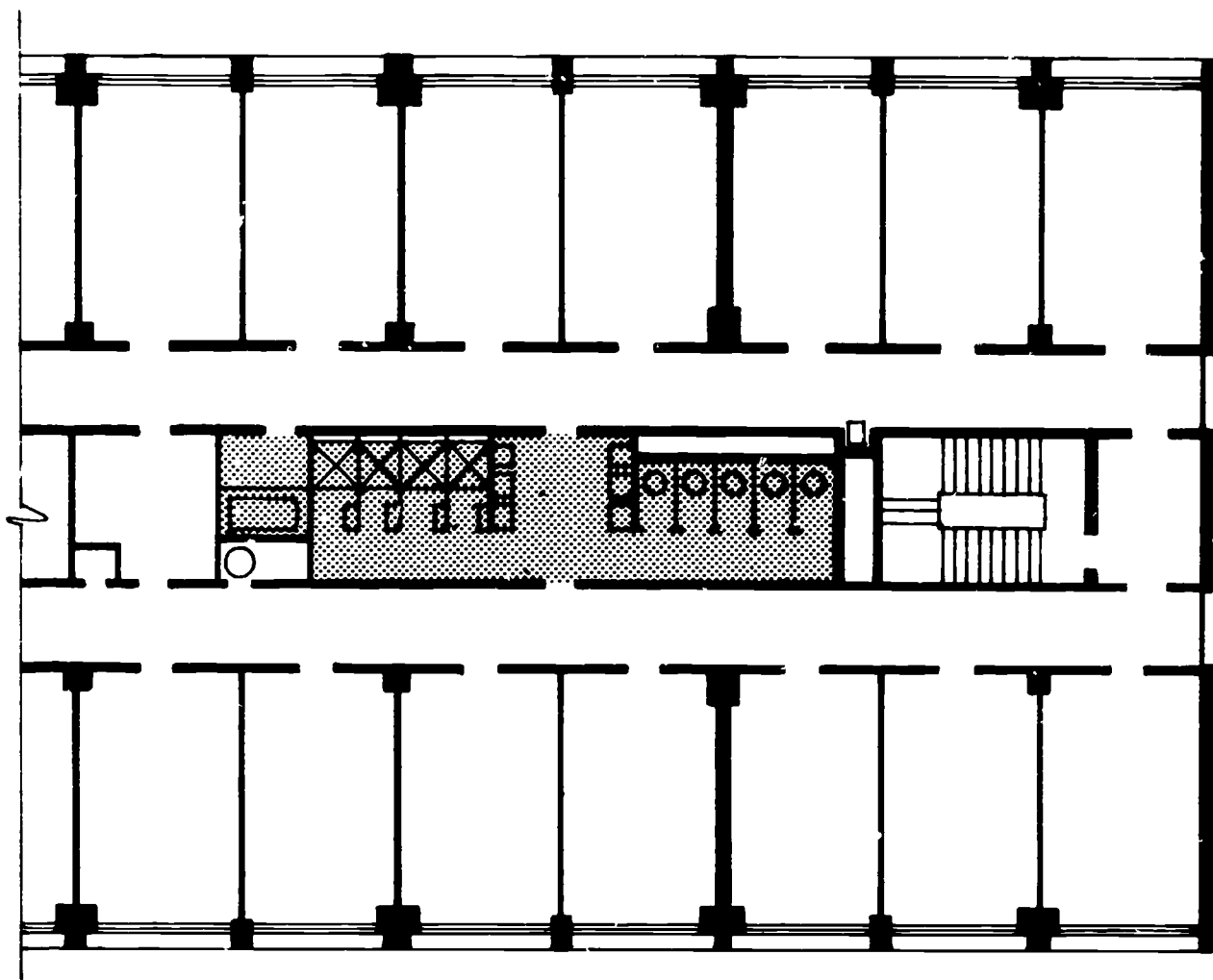

GANG BATHROOMS



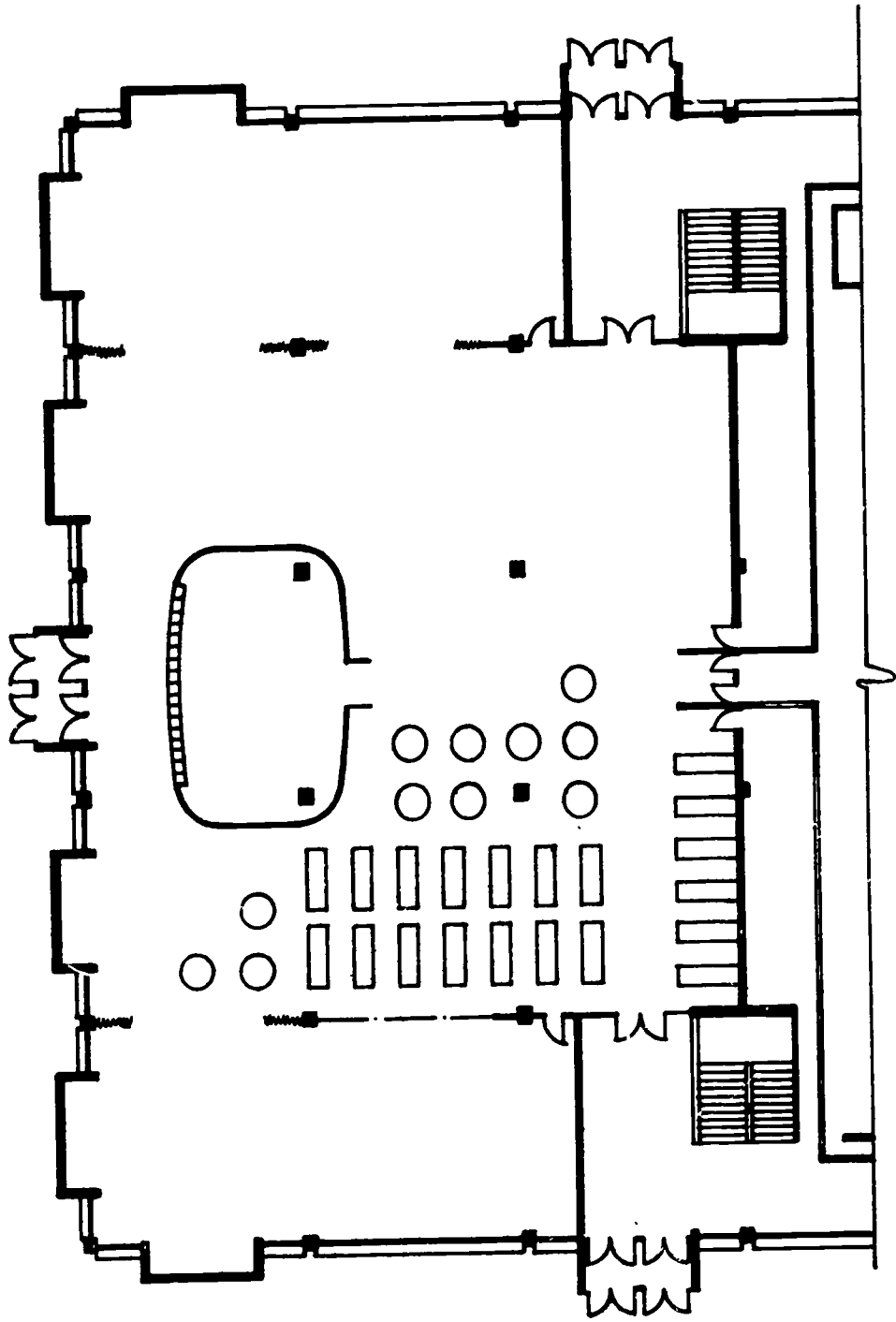

LARGE DINING ROOM, DIVISIBLE BY OPERABLE PARTITIONS INTO THREE ROOMS OF VARIED SIZE.

providing environmental support to the personal interaction of students, both new and old, since academic assimilation and involvement are not restricted to the classroom or student room. However, care must be taken in the areas programmed for recreation so that they truly accommodate the intended activities. Otherwise, the spaces will fail to accomplish the intended purposes.<sup>23</sup> Evaluation of the success of social spaces in meeting their intended needs indicate that a variety of smaller spaces are likely to be the most popular and useful.

Student complaints are universal concerning the typical residence hall's main lounge (Plate 13). It has been relatively unpopular with students because of its large size and lack of individualized space. The tendency is for this space to become monopolized by one small group, or even one couple, making other individuals or groups hesitant to intrude. A recent study,<sup>24</sup> shows that 32 percent of student residents use the lounges less than once a week and that 36 percent of them use the lounge only one to three times a week. The lounge fails because it cannot simultaneously accommodate incompatible activities. The piano, TV set, and sofa are not appropriate companions. The main lounge, furnished with expensive, hotel-like furnishings, is usually designed, and is mainly suited, for large, quiet groups. It is seldom used by the students for entertaining friends.

The suite living room (Plate 14) can accommodate both quiet and active uses, although conflict occurs when the space attempts to serve socializing and study. On the campuses at Santa Cruz, San Diego, and Irvine, successful experiments have been made in treating these spaces as apartment living rooms, with freedom of intervisitation.

Small "date" rooms (Plate 15), as observed on some campuses, are popular when not overly supervised. However, date rooms seem to be an artificial solution to a problem better solved by a wider range of social rooms.

Television rooms are losing their effectiveness as social centers because the diminishing cost of television sets makes it possible for students to have individual sets in floor lounges or in their rooms.

Spaces allowing vigorous activity are important to all students, especially men. At present, such activities (if provided for) are usually located in drab, ill-equipped basements. In those residence halls where suitable spaces are accessible to food sources and open occasionally to both sexes, they are very popular and used continuously.

The comparison of expenses for furnishings between main lounges and recreation spaces shows the latter to be less expensive. Since main lounges are infrequently used, money spent on them is largely wasted. To provide more useful variety than is now available, the question of area allocation to main lounge—recreational spaces should be carefully considered.

---

<sup>23</sup>Real Estate Research Corporation. Analysis Student Housing Market and Alternate University Housing Programs. 1963-1975. Prepared for The Board of Regents, University of California, Berkeley, California, January 1965.

<sup>24</sup>*Ibid.*

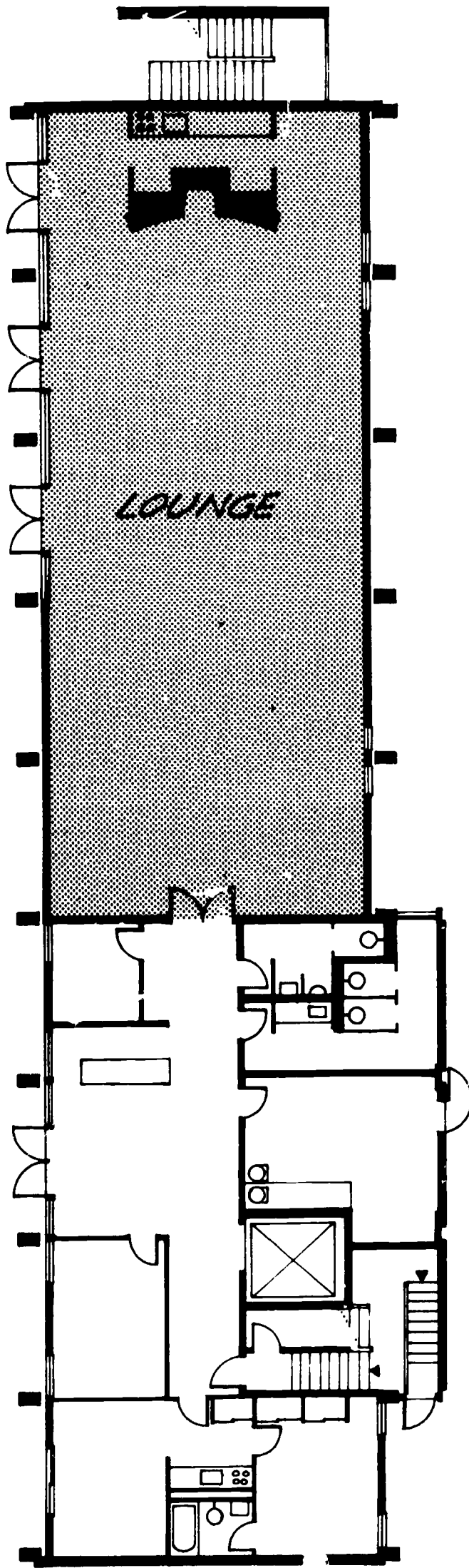

THE LARGE LOUNGE.

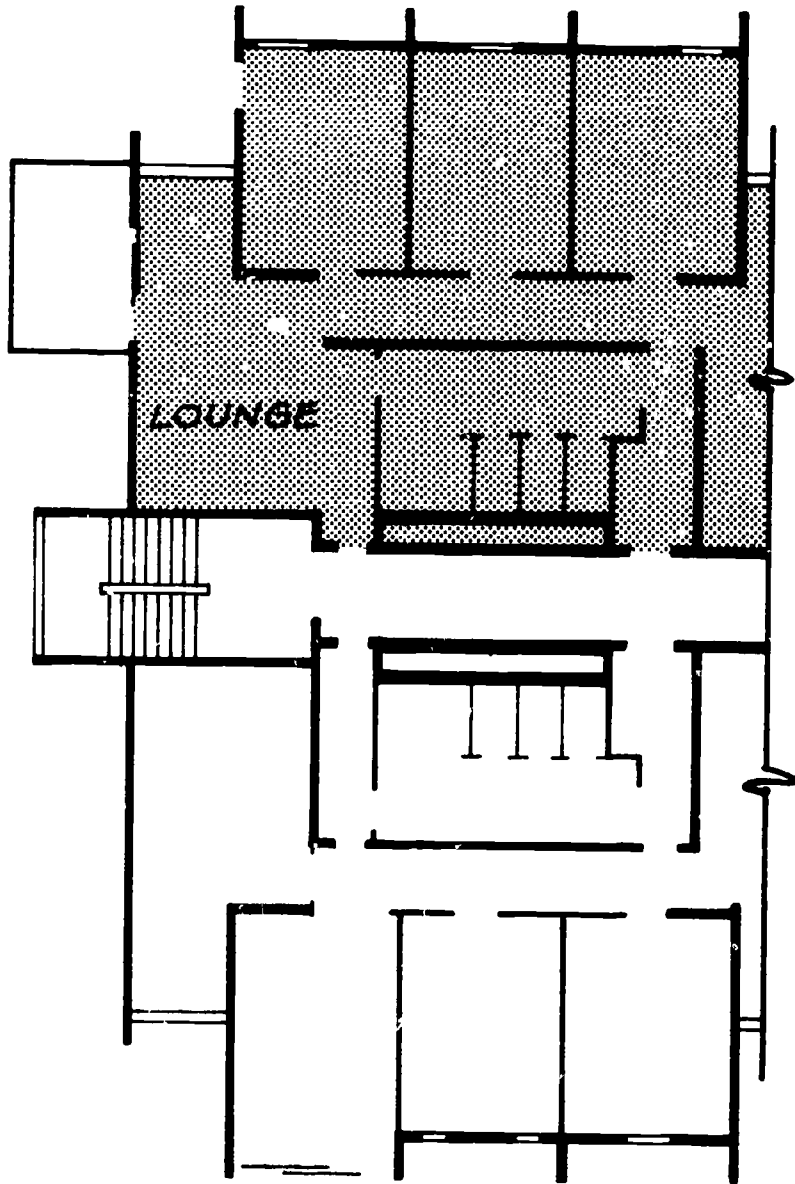

SMALL LIVING ROOMS FOR GROUPS OF  
6-8 STUDENTS.





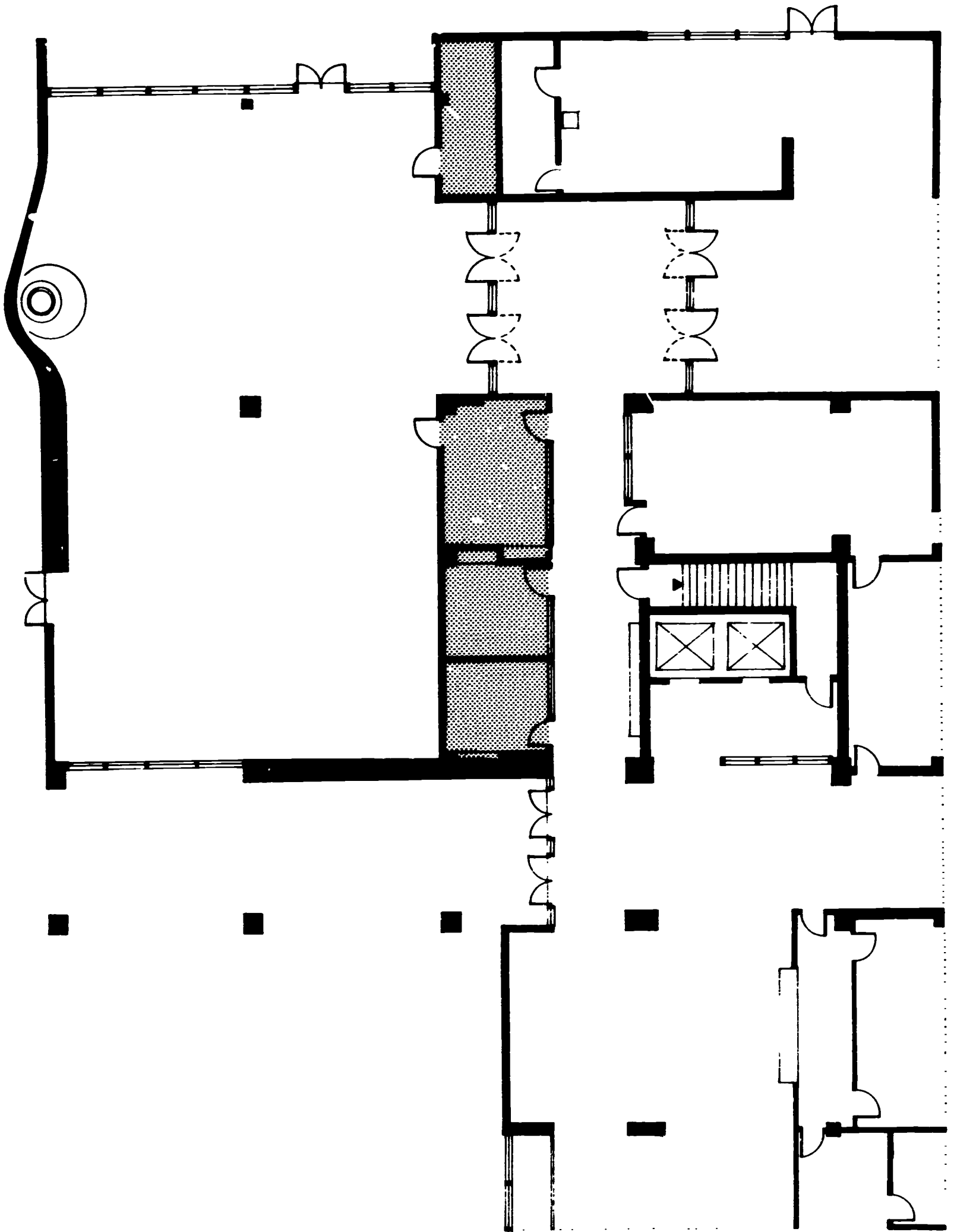

*"DATE" ROOMS AND LOUNGE FACILITIES.*

One way to provide close at hand recreational space, especially practicable at the University of California, is to equip the roof-tops of residence halls for recreational activities. The appeal of roofs is demonstrated at San Diego, where roofs having a slope of ten degrees and reached only by climbing a drain-pipe are used by both men and women extensively, although not with approval of the administration. Problems arise in regard to construction, cost, controlling vents, and flues; nevertheless, roof-tops are a desirable location for many activities.

Another important form of recreation, but seldom provided for, is student hobbies. The mess and equipment involved in many hobbies suggest that perhaps older utility buildings on campus could provide spaces for these activities. It is more difficult to foresee the needs of hobbyists and expensive to introduce into residence halls the sufficient acoustically-isolated spaces for them.

#### 4. Cultural

The comradeship of undergraduates will *never* breed the spirit of learning. It must include the older *men*, teachers . . . So long as instruction and life do not merge in our colleges, so long as what the undergraduates do and what they are taught occupy two separate air-tight compartments in their consciousness, so long will the college be *effectual*."

(Woodrow Wilson, "The Spirit of Learning.")

Residence halls can participate in the overall academic environment of the university with the inclusion of facilities for library, music, and discussion. It is part of the job of housing to smooth the transition from green freshmen to sophisticated seniors.<sup>25</sup> At Harvard University, house libraries relieve some pressure on central facilities, creating a sense of academic community as well as making books more readily available. Inexpensive paperback libraries are quite adequate for providing both stimulating and enjoyable reading materials within a residential atmosphere. Eventually these libraries will include random-access listening stations; it is therefore advisable to initially provide adequate distribution access into the structure.

Music rooms can also serve as tape and record libraries, although the centrally located equipment will be used less frequently as more students can afford their own equipment. All music involves a noise factor which must be considered.

Formal academic classes in residence halls present difficulties in mechanical services and density beyond the capability of most residence hall structures, but informal classes and seminars can be successfully held in the social spaces in the hall.

---

<sup>25</sup>Harold C. Riker and Frank G. Lopez. *College Students Live Here: A Study of College Housing*. New York: Educational Facilities Laboratories, Inc., 1961, p. 14.

## 5. Service and Storage

The university must provide facilities for (1) maintenance of buildings, (2) the mechanical and electrical equipment, and (3) overflow storage from student rooms.

Increasing affluence of students and the growth of disposable articles have increased space requirements for efficient trash collection and removal. Trash chutes, central collection facilities, and dumping trucks are required to handle present volumes of trash. Too often this involves the ugly exposure of the trash while awaiting collection, as well as the considerable fire hazard.

Efficient maintenance of electrical and mechanical systems requires easy access without the invasion of student privacy. Equipment should be so located.

Out-of-season and seldom-used student property is usually stored in inexpensive areas of a building, but these are often the least accessible. This situation could be relieved by more adequate storage provisions in the student room. Student and service storage should be in separate areas and away from heavy traffic areas such as laundry and recreation rooms. Bike shelters, surf boards, skis, and scuba gear present special storage problems that require careful consideration. All student storage areas must be lockable.

## 6. Circulation and Interrelation of Spaces

The residence hall is a social organism. The relationship of student rooms one to another and to the public and service rooms make up a total environment most conveniently studied as a hierarchy of spaces. The hierarchy is determined by the student activities and the physical characteristics of the building. Following is a hierarchy of typical unit sizes in university housing:

Students	Unit
1-2	Student room
4-12	suite
16-24	group
48-72	house or floor
120-800	hall, building or college
1,200-4,800	complex of halls
12,000-27,500	campus

Unit size is defined by building spaces, activities related to space, and by agents of regulation and control. For example, a number of rooms served by a bathroom constitutes a suite, group, or floor. A number of rooms under the direction of a resident assistant will establish a unit.

All the rooms on one floor having common access and services may also be considered as a unit.

The predominant traditional pattern is the familiar double-loaded corridor arrangement wherein the unit is one floor of a residence hall (Plates 11 and 16). This plan offers easy control opportunities. With a group of 48 to 72 students, it facilitates the organization of intra-mural and academic activities.

At the Irvine campus, the eight or nine students who share a bath and a living room determine unit size. The San Diego campus has units of ten students, this number deriving from the maximum occupancy permitted to share space without a second exit under the building code. Another source of group size derivation is the optimum number sharing bathroom facilities.

Efficient space utilization requires that the circulation area comprise the smallest possible percentage of the total area. Studies of existing student housing show the efficiency percentage varying from 7 percent to 25 percent (Plate 17). Although it is advantageous to reduce circulation areas, building safety codes prescribe minimum areas and arrangements. Corridors which are mean, cramped, and possibly dangerous in an emergency, are not acceptable.

Economy is the obvious feature of double-loaded corridors because core plans require more circulation area (Plate 11). When each student has a single room, economy of circulation space is difficult since each room must have a window on the periphery of the building. This arrangement, in its simplest configuration, requires extremely long frontages. Irregular building configurations to reduce corridor space must be considered in a cost context also.

Elevators for freight and disabled students are useful in all buildings. In high-rise buildings, passenger elevators are essential although they tend to make insular entities of each floor. This problem can be reduced by skip-stop elevators stopping at unit lounges linking two floors. The initial expense of good elevators is not offset by cheap ones requiring much maintenance. Competent servicing can be provided by including maintenance contracts in purchase agreements. The better service an elevator gives, the less likely it is to be abused. Elevator switches, as common targets of student pranks, must be tamper-proof. Escalators are too expensive and have far too great a passenger capacity to be viable alternatives in residence halls.

The location and intensity of such fixed facilities as baths, stairs, and elevators are the main inhibitors of future rearrangement. The URBS approach permits choice based on requirements rather than custom and makes possible alteration to new unit sizes to satisfy rapid social change.

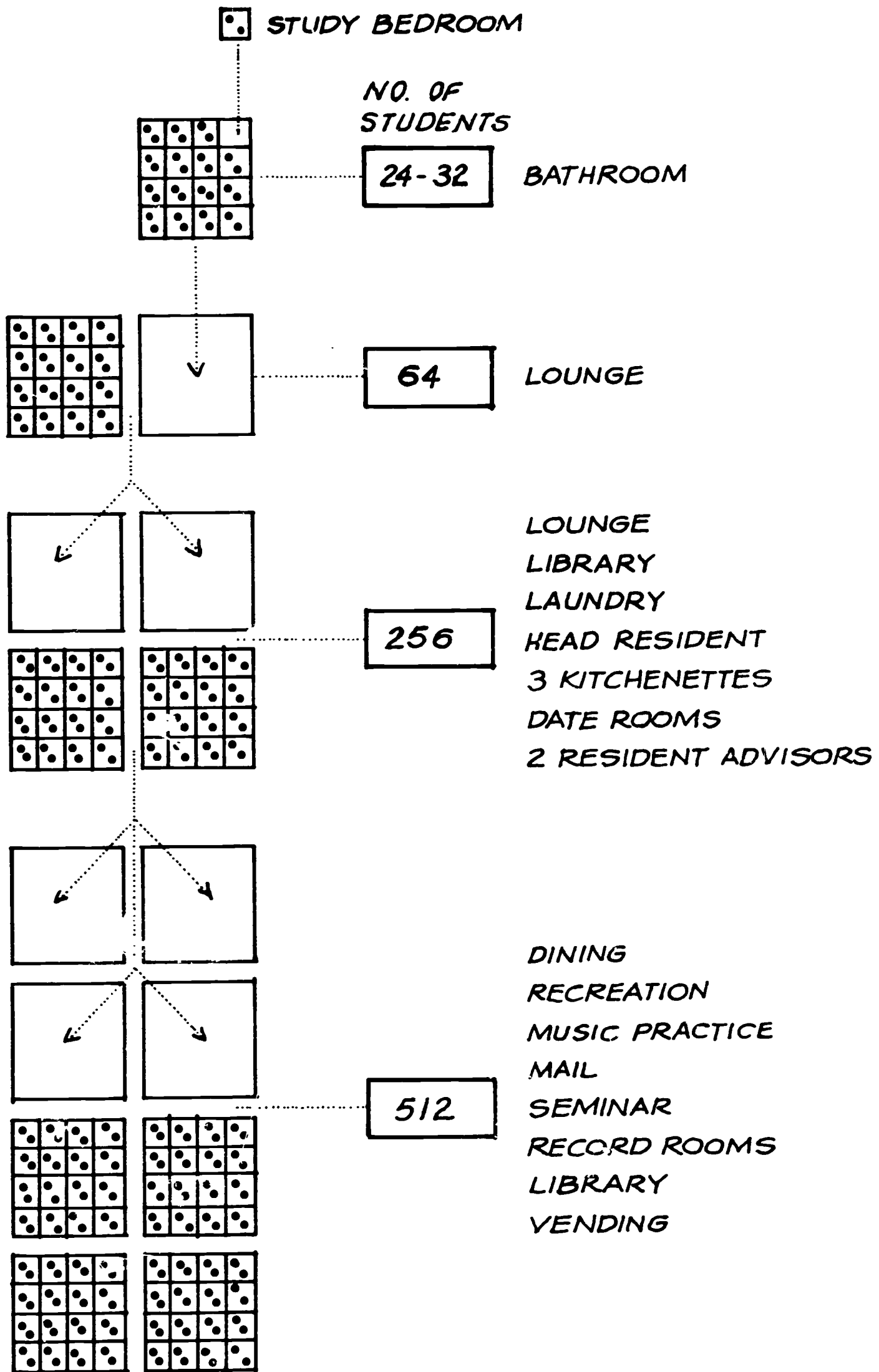

**HIERARCHY DIAGRAM.**  
**DOUBLE LOADED CORRIDOR, HIGH RISE BUILDING.**

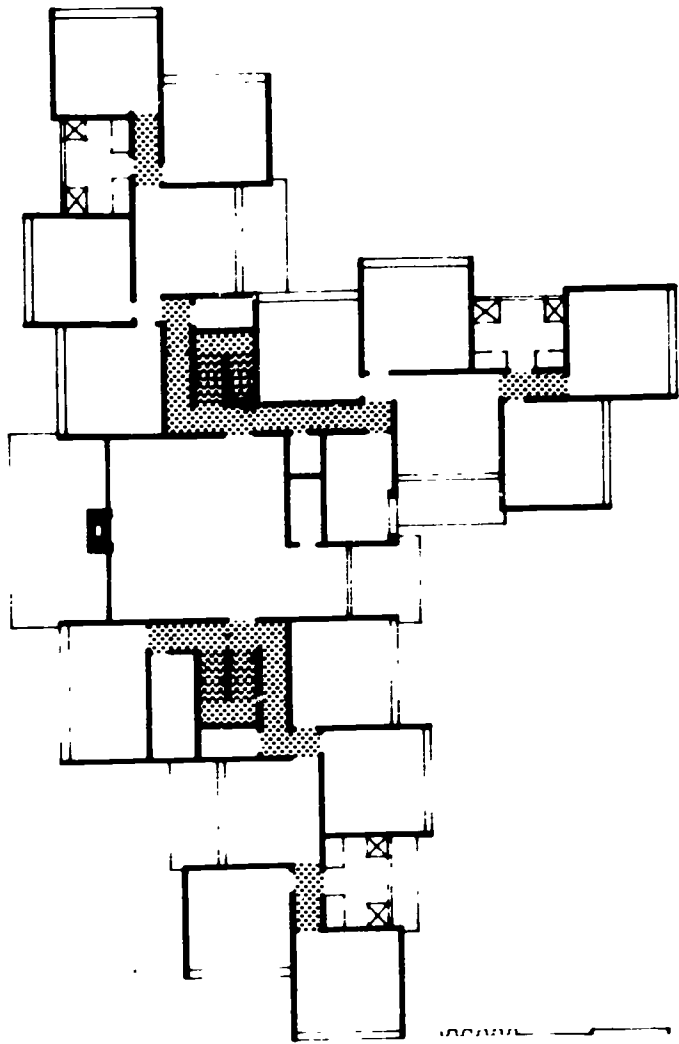

**a** 7%

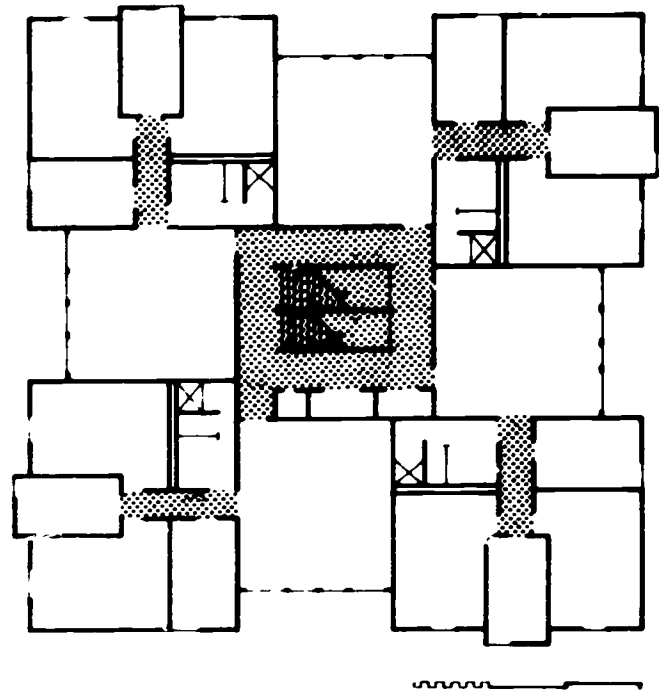

**b** 14%

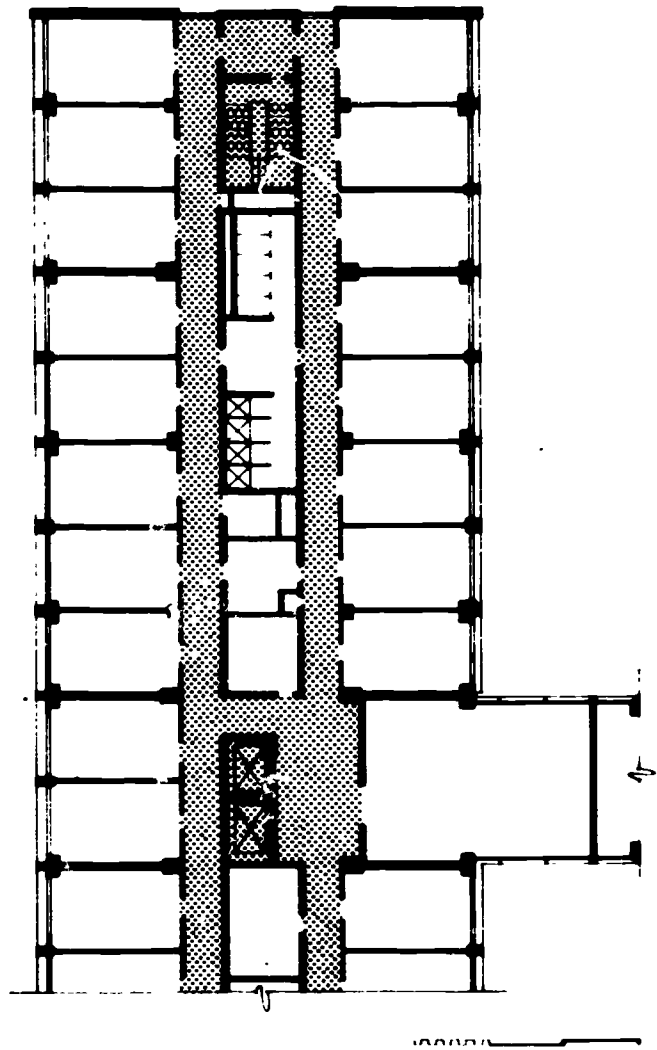

**c** 25%

RATIOS OF CIRCULATION TO GROSS AREA



Hence the initial placement of the fixed facilities is a critical decision.

A major determinant of environment is the access to movement from space to space. Those spaces grouped about a room or wide corridor make up a more residential environment through the use of attractive carpets, colors, and materials. Corridors can be more fully utilized; for example, conversation spaces that do not impede circulation can be provided by window seats and railed landings. Although stairs must conform to fire regulations, their configurations can be a pleasant contribution to the environment.

## VII. ADAPTABILITY

The universal concern, reiterated by all involved in student housing across the country, was the need for variety or diversity in the accommodations offered to the student. However, today's diversity will not satisfy tomorrow's students. Our pattern of life is evolving so rapidly that no single configuration will be suitable for the life of the structure. Consequently there is great need for a building system permitting changes in the internal configuration with the passage of time. Both initial variety and long-term adaptability are a cornerstone of the URBS project.

### A. VARIETY

A variety of specific arrangements can be planned for rooms before they are constructed. Also the basic plan arrangement can be changed from one floor to another so that there is, for instance, a mix of double or single rooms on one floor and suites or apartments on another. (See Plates 18 and 19.)

To date, in approaches of this type, the specific plan configurations provide little possibility for future change in terms of structure, mechanical services, and partitions within a cost context. Certainly, variety and adaptability of student space can be attained by providing spaces convertible in size and shape by demountable partitions, smaller and more widely distributed bathrooms, and movable furniture, permitting students to define their own space—but the cost of such features must be reduced. This is one of the major objectives of URBS.

### B. CHANGE

Pressures for environmental change in university housing are exerted by changing student mix (ratios of single to married, male to female, graduate to undergraduate), social evolution, affluence, and student identity. Present physical environments predominantly have been the expression of stereotyped ideas by an older generation concerning how a student should live, developed without sufficient inquiry into the character of that student and how he wants to live. Revision of present environmental forms is necessary, not only because of their unpopularity, but also because they will not accommodate changing student populations. A cogent presentation of criteria for new student housing is provided by URBS Performance Specifications with the purpose of persuading industry to develop building components permitting construction of a more responsive environment.

### C. STUDENT MIX

Existing facilities were designed when male undergraduates constituted the majority of students at the university. Women students, comprising only 24 percent of the enrollment a decade ago, now account for nearly 50 percent of total enrollment. The result is that more women than men will have to be accommodated in facilities for either sex, and far more latitude for

VARIETY IN A HIGH RISE: PLAN OF FLOORS 2 - 12 SHOWING  
VARIED SHAPES OF ROOMS.

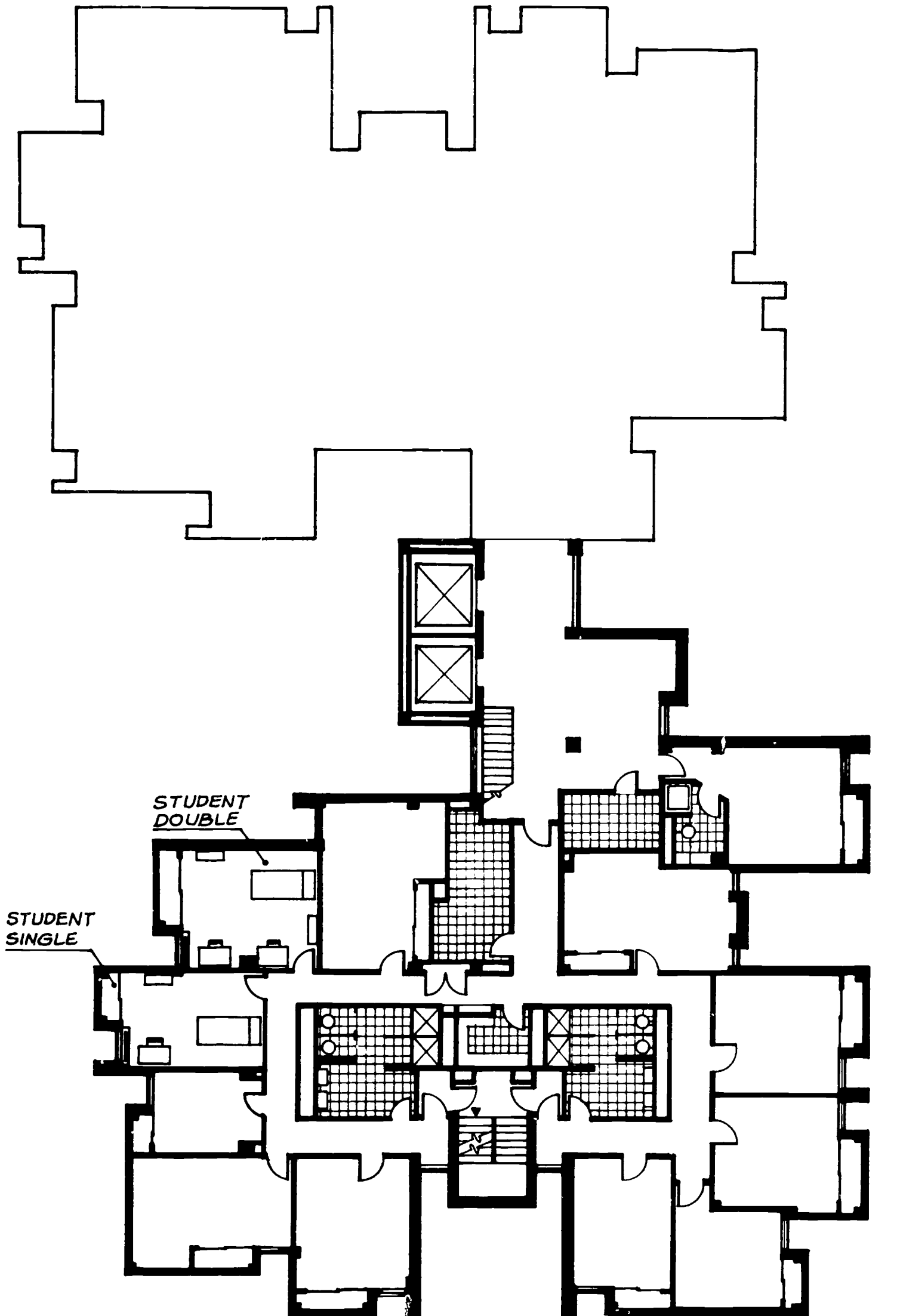

VARIETY IN A HIGH RISE: PLAN OF FLOORS 13-15 SHOWING STUDENT APARTMENTS AND CHANGED BATHROOM ARRANGEMENT. UNIVERSITY OF COLORADO, BOULDER.

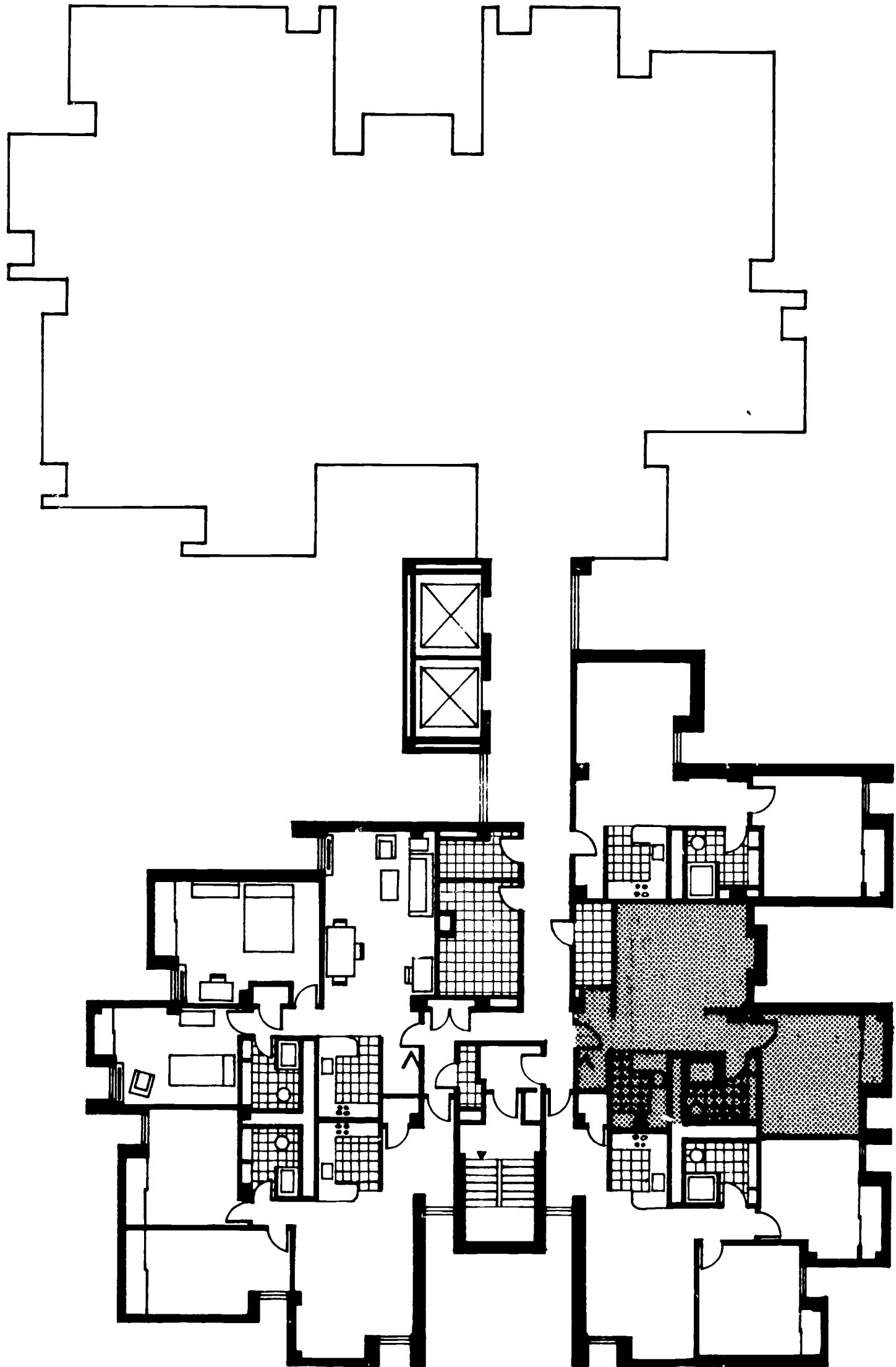

student decoration of living space will help to ensure that future facilities can comfortably accommodate women.

Graduate students will represent an increasing proportion of total enrollment. The needs of graduate students dictate more acoustical isolation, less control, and fewer social spaces than are required by undergraduates.

There has been little inclusion of formal academic activities in residence halls (except at San Diego and Santa Cruz campuses), but student housing should provide the necessary acoustical isolation, rights of way for communications, and ease of access to accommodate academic activities in the future.

#### **D. SOCIAL EVOLUTION**

Architecture is the physical expression of a society. In the past, social evolution was sufficiently gradual so that architecture could project that social image as a fixed environment. Today's needs require that all building parts provide maximum adaptability to rapid change, within a cost context and without undue sacrifice to prior expressions.

In the expression of change, this study found a broad gap between residential housing needs as defined by students and those same needs as defined by elder non-students. Thus it is difficult to design satisfactorily student housing that today's students want to live in, because our generation evolved through an entirely different social and physical environment from that of today's student. Furthering the principle, today's student values will be equally irrelevant for the successive generations residing in the building during its required forty plus years' life span.

Points of view concerning the relationship between the sexes or beliefs about social and academic interaction are but two of the attitudes manifested in particular features of student housing. Since these changing attitudes cause shifts in living patterns, only the sufficiently adaptable environment will be of use in meeting the evolving needs. For example, the date rooms of yesterday with a wall removed could become seminar rooms of tomorrow. The double student room with a wall inserted could become two rooms for tomorrow's graduate students. The large public lounges, with appropriate ventilation, lighting, and movable partitions would be much more useful as multi-use spaces. Today, only intuition guides us concerning tomorrow's social needs; therefore only those designs that accommodate adaptability will be of continuing validity.

#### **E. AFFLUENCE**

The amount of human energy expended in work situations can be expected to decline through the application of man-made energy, particularly electricity. The progress of affluence in the past forty years (the minimum life of a residence hall) has caused some radical changes in human activities. What implications this continuing progress will carry for the next forty years is beyond prophecy. Yet our environment, though bound in fixed structural shells, must be adaptable to these future needs.

For instance, within the next forty years, it is postulated that the level of affluence will enable many to take a sabbatical from their occupation for an extended period of uninhibited study. The university student housing might well become the "office" for these more mature scholars as well as temporary homes for their families. Our present facilities, however, would be singularly incapable of accommodating such a program.

#### F. INDIVIDUAL STUDENT IDENTITY

Present student housing inhibits the expression of individual identity. The resident is inconvenienced, frustrated, and cramped for the sake of initial economy and because existing construction materials and practices do not allow for the necessary individualization of space. To satisfy both needs—economy and individualization—the major areas of any building must require very little maintenance. Resolutions of this conflict are at hand. Wall coverings that permit unrestrained decoration are being used; functional furniture adaptable in form and layout has been on the European market for some time; demountable wall partitions are already in use in some new buildings.

By providing industry with sufficient incentive, new components and techniques can be made available for the purpose of providing the student with far more expressive control over his own room. It is imperative to provide the resident with the basic materials to please himself, and to encourage his creativity in the process.



## VIII. OPERATIONS

### A. ADMINISTRATION

The Standing Committee on Residence Halls<sup>26</sup> earlier recommended the establishment of incentives to efficient operation of university student housing. The Regents have authorized financial incentives. The URBS project will provide design incentive to the architect. However, the adaptability incentive in the system itself will present problems of administration and accounting. As the URBS project progresses, it will work closely with University administration to ensure that the promise of the system is fully realized and that administrative problems are anticipated and minimized insofar as possible.

The University gains in several ways by attracting summer conferences to its housing facilities. Increased benefits would result from operating its student housing all year round. Even with the adoption of the summer quarter, much space is empty during this time. If it were filled by conferences, the University could maintain its housing staff all year. Moreover, such conferences can bring additional revenue for the enrichment of the student housing program.

In attracting conferences, the University must provide the amenities to which non-student delegates are accustomed. It is not satisfactory to house families in quarters lacking food storage or food preparation facilities and served by gang bathrooms.

### B. MAINTENANCE

Maintenance requirements increase with the passage of time. Performance of a building is determined by materials, manufacturing standards, installation methods, and use. There is a psychological element in use that may alter the conditions otherwise determined solely by technical factors. Pride in the building affects the way in which its occupants use it. For example, carpeting has been successful in hallways, students' rooms, and even dining rooms largely because it induces quiet, inspires pride, and commands respect.

Maintenance of materials and mechanisms is divided into five classifications:

1. Cleaning: e.g., the removing of soil from walls and the stripping and rewaxing of tile floors.
2. Refinishing: e.g., the revarnishing of a wood floor or repainting of walls.
3. Servicing: analogous to cleaning and refinishing but applying primarily to mechanical equipment. Examples are replacing filters, oiling lock sets, and similar routine operations.

---

<sup>26</sup>University of California. UC Standing Committee on Residence Halls, meeting of August 29 and 30, 1966, Hilton Inn, San Francisco International Airport.

4. **Repairs:** e.g., the replacing of tiles in a floor, valves in heating lines, or repairing door closers.
5. **Replacement:** e.g., the replacing of a complete unit, element, or component, from a lockset to a heating system.

The cost of maintenance is determined by the frequency of the above operations, the time required for the operation, the materials used, and the wages of labor.

The significance of the above five classifications becomes apparent when it is realized that building components decay at different rates. Structural framing often has a 100-year life, while heating systems may last thirty years and partitions ten years. Obviously then, a wall surface requiring refinishing (Class 2) every ten years should not be installed in a wall structure needing repair (Class 4) every five years.

In addition to wear, there are three other causes for the replacement of components even though they may be functioning adequately. These are obsolescence due to technical, social, and aesthetic reasons.

The technical obsolescence of a component occurs when a new product much superior becomes available, even if at a higher initial price.

Social obsolescence is occasioned by a strong change in fashions and/or by economic pressure. For example, air conditioning may be installed more for reasons of social status than to satisfy a climatic situation.

Aesthetic obsolescence comes to a finish or a component, such as the exterior of a building, when tastes of the society change significantly.

### **C. SELECTION OF MATERIALS**

Materials also can be divided into five classifications:

1. **Hard and absolutely resistant materials.** Properly placed and supported, these are almost indestructible, i.e., ceramic tiles.
2. **Hard, homogeneous, and refinishable materials.** If damaged, such materials can be refinished; and the finish may even improve with wear, i.e., wood and the patina on hardwood paneling.
3. **Vulnerable but easily repaired materials,** i.e., gypsum board.
4. **Vulnerable but easily replaced materials,** whose low initial cost, little need for maintenance, and easy replacement make them inexpensive. The ultimate of this kind of material is the disposable, "Kleenex" type of material.

5. Hard-skin materials used only for surfaces. These materials have a protective shell. Once this is pierced, the material deteriorates very rapidly, i.e., melamine plastic finishes on furniture.

Each of the above material classifications has differing value in differing circumstances. As a theoretical example, it may be better for the construction of partitions to use a vulnerable but easily replaced material having a four-year life than to use a hard, homogeneous material of a forty-year life. The vulnerable material needs no maintenance, and can be changed with new group of residents. It thus may respond better to individual demands, technological advances, and fashion. (Maintenance may cost many times as much as the material itself.)

URBS expects the development of components permitting better control of maintenance costs than has heretofore been possible.

#### **D. MAINTENANCE CONTRACTS**

The maintenance contract is an effective way of controlling maintenance cost, particularly of complex mechanical equipment. The contract will be most effective if included in the bid process, for two reasons: one is that maintenance costs can be more accurately predicted over a long period of time; secondly, manufacturers are inclined to bid equipment of higher quality if they know that they are responsible for its maintenance over a long period and that maintenance costs are to be known by other potential customers.

The time period of the maintenance contract must be determined by the nature of the equipment and the desires of the owner. In the URBS project the heating-ventilating-cooling component will be bid with five years' maintenance—full labor and material cost—included in the first price. The bidders also will be required to submit firm prices for an additional fifteen years' maintenance to be contracted for at the option of the University. Bids will be evaluated not only on the initial cost, but also on the cost of the maintenance, and the estimated cost of operation. Thus, the annual cost of ownership will determine the successful bidder.<sup>27</sup>

#### **E. MATERIAL FAILURES IN BUILDINGS**

Consultation with operations and maintenance personnel at the University of California and other universities revealed certain failures so consistently that they deserve attention:

1. Heavy, solid-core doors break wall materials adjacent to the door frames.
2. Movement of baggage and furniture leads to damaged walls in corridors, as does horseplay in game rooms.

---

<sup>27</sup>In this way, the URBS bid price for HVC installed cost was \$9,288,252, with five years maintenance for the cost was \$10,757,737, and with twenty years of maintenance and operation \$14,165,792 (assuming no inflation). These figures show the relative insignificance of first cost in the real price of mechanical equipment.

3. Metal shower partitions deteriorate rapidly.
4. Ventilation in shower rooms is inadequate. The equipment is rarely of sufficient quality. If air temperature is comfortably high, air movement is insufficient, causing paint to peel because of humidity.
5. Shower-room floors and walls leak. The wall-floor joint is particularly critical.
6. Elevators are abused and their controls invite tampering.
7. Acoustical ceilings are frequently damaged.
8. Door closers and the hardware of sliding closet doors fail.
9. Difficult access to plumbing creates high maintenance costs.
10. The flimsy nature of plastic diffusers and their attachment to light fixtures create expense.

## IX. FINANCE

The translation of the user requirements into the URBS performance specifications will be done with full consideration of financial feasibility. This includes cognizance of all cost factors, the balance among these factors, and the understanding of what a student may be able to afford. The factors are illustrated in Tables 5, 6, and 7.

Capital costs, as measured by the Engineering News Record (ENR) indexes, have been rising steadily for a half century, accelerating in recent years to an average rate of 4.5 percent per year. Operating costs, which include high proportions of labor, have also steadily increased with a recent noticeable acceleration.

Yearly operational costs constitute more than half of the room costs and thus seriously affect the room rental rate to students. A building system that affords reduction in either operating or maintenance costs could provide financial alternatives that would permit *either* a reduction of costs and rates *or* would allow for greater satisfaction of user requirements. *A \$1.00 per year per student reduction in operating or maintenance costs would permit a \$15.00 additional initial capital outlay without changing the total costs or the student rates.* The bases for these conclusions are hereinafter developed.

TABLE 5  
1966 STUDENT ROOM AND BOARD COSTS  
(PER YEAR, IN DOUBLE ROOM)

(1) Debt Service	\$164 <sup>a</sup>	
(2) Debt Service Reserve	44 <sup>b</sup>	
(3) Furniture and Equipment Replacements, Alterations, and Contingencies	<u>32</u>	
(4) Subtotal		\$240
(5) Operations and Maintenance		<u>180</u>
(6) Student Room Only		\$420
(7) Board Costs		<u>520<sup>c</sup></u>
(8) Total Residence Hall Costs		\$940

<sup>a</sup>Debt Service for room and associated general facilities only.

<sup>b</sup>Reserve for bonded debt only.

<sup>c</sup>Includes (1) through (5) as applicable to dining and kitchen facilities. Includes approximately \$240 raw food costs, food service labor, other operational costs and pro-rata debt service for each food service facility.

**TABLE 6**  
**ILLUSTRATIVE MODEL FUTURE STUDENT ROOM**  
**AND BOARD COSTS**

Item	1966	1986	2006
Debt Service	\$164	\$164	\$164
Debt Service Reserve	44	44	44
Major Repairs, Replacements, Alterations and Contingencies	<u>32</u>	<u>56</u>	<u>97</u>
Subtotal (Net Revenue Needs)	\$240	\$264	\$305
Operations and Maintenance	<u>180</u>	<u>313</u>	<u>544</u>
<b>TOTAL</b>	<b>\$420</b>	<b>\$577</b>	<b>\$849</b>

**TABLE 7**  
**ILLUSTRATIVE MODEL FUTURE STUDENT ROOM**  
**AND BOARD COSTS**

Item	1966	1986	2006
Debt Service	\$193	\$193	\$193
Debt Service Reserve	54	54	54
Major Repairs, Replacements, Alterations and Contingencies	<u>20</u>	<u>35</u>	<u>60</u>
Subtotal (Net Revenue Needs)	\$267	\$282	\$307
Operations and Maintenance	<u>153</u>	<u>266</u>	<u>462</u>
<b>TOTAL</b>	<b>\$420</b>	<b>\$548</b>	<b>\$769</b>



The yearly costs incurred in student housing and the bases for rates chargeable to students can be expressed simply by the formula:

Debt Service + Department Service + (Furniture and Equipment Replacements, Alterations, and Contingencies) + (Operations and Maintenance) = Total Yearly Costs.

The Debt Service is related to the outstanding bonded debt and The Regents' loans on the capital expenditures made to date. The replacement values of University of California residence halls at January 1966 prices range as follows:

Residence Halls Project Costs (double occupancy, excluding dining facilities) — \$4,660 to \$7,820 per student.

The University-wide administration established austere student housing target costs for 1966. The target costs were:

Residence Hall without dining—double occupancy	=	\$4,900/student
Residence Hall with dining —single occupancy	=	5,900/student
Dining and kitchen allotment —	=	900/student
Commuter student dining allotment	=	300/student

All the above figures are exclusive of land acquisition costs, parking, and utility extensions.

Building costs have averaged 76 percent of project costs. The remaining 24 percent is devoted to furnishings, landscaping, utilities, architect's fees, administration, and interim financing charges. While the URBS project is more concerned with construction costs, *the interrelatedness of all factors must be considered.*

University of California's average 1966 room and board costs per student living in a double occupancy room are summarized as shown in Table 5.

The Debt Service and Debt Service Reserve will increase in almost direct proportion to the increase in capital expenditures, based on the premise of 100 percent financing and a relatively small range of interest rates. Once the capital expenditures are established, these two major costs remain essentially fixed over the capital outlay amortization period of forty years.

Line Item No. 3 in Table 5, for Furniture and Equipment Replacements, Alterations, and Contingencies, will need to be continued for the time period that the debt service reserve requirement remains unsatisfied. This reserve requirement may not be satisfied in the foreseeable future, so long as more units are added to the University of California Housing System. This item may well be insufficient in the immediate and long-term future since the backlog of needs will increase as buildings, furnishings, and equipment become older.

Operations and Maintenance expenditures (line item no. 5 in Table 5) include a high proportion of labor costs which are rising each year. This item exceeds the Debt Service (line item no. 1) even now.

Tables 6 and 7 are *illustrative models* indicating sizeable reductions in total costs in later years, attainable if operational cost reductions can result from selective capital expenditures. The interviews with many housing personnel and consultants, as well as preliminary cost studies, give confidence that the savings depicted in Tables 6 and 8 can be attained.

Table 6 illustrates the effect of a 3 percent yearly compounded increase in equipment replacement and operations and maintenance costs *on the student room portion* in Table 5 while holding the debt service constant for the existing projects. It is recognized that the average debt service will rise as new units with 100 percent financing are added to the housing system.

Table 7 illustrates the effect assuming that a modest \$40 per year reduction in equipment replacements and operations could be attained with additional capital costs of \$600 (the 1 to 15 ratio).

The foregoing analyses have been confined to residence halls for single students. Similar techniques of analysis of capital and operations costs may be applied to apartments for either married students or single students.

The effects of the proposed four-quarter academic year on housing costs and revenues have not been studied.

## **X. SUMMARY**

### **A. OBJECTIVES**

The URBS objectives recognize the University's competitive position with respect to private housing and the University's academic nature. These objectives include:

1. Accommodation of student preferences, whether married/single, undergraduate/graduate, men/women.
2. Architectural freedom, including unlimited configuration—low-rise/high-rise, with variety and adaptability.
3. Integration of academic elements, both formal and informal, into the student residences.
4. Lowest possible student annual charges, considering construction, maintenance and operation costs.

### **B. EVOLUTION**

Satisfactory living arrangements have been provided in past residence halls both in the United States and abroad. Although they do not reflect current requirements in many instances, circumstances dictate that URBS should enable their duplication wherever desirable.

### **C. USERS**

1. Acoustical separation of each space is required. Quiet is an essential factor in the academic orientation of students. It should be achieved within the lower student-cost context.
2. Durability of finishes required for undergraduate excesses should not inhibit the human and academic atmosphere.
3. Individuality and energy-release should be permitted, but channeled.
4. Equal consideration must be given to both sexes.
5. Furnishings should be comfortable, adaptable, durable, and economical.
6. Storage should be accommodating, both as to kind and quantity, to reflect sex, affluence, and individual differences. Food preparation should be considered on a limited basis within the residence hall. Adaptability by the building is preferred above adaptability by the occupant, in order that each of the various user types can be accommodated with minimal distortion of basic needs. Physical handicaps of the occupants should be considered. Electronic communications should be considered by providing maximum freedom for future rights of way.

## D. ACTIVITIES AND SPACE

### 1. Student Rooms

- a. Emphasize academic requirements.
- b. Multiple occupancy with insufficient separation causes conflict between differing activities. Therefore, provide more singles than in existing university residences. Furnishings might also provide separation.
- c. Furnishings must adapt to individual preferences. Beds and chairs should reflect increasing physical size of the average student.
- d. Room walls need to be relocatable to provide for variations in occupancies and requirements.
- e. The walls, doors, and surface treatment must provide adequate acoustic separation and attenuation for study and for privacy.
- f. Room heating and ventilation should include individual control, with provision for addition of cooling.
- g. Clean, odorless air should be controllable to suit both study and social activities.
- h. Electrical and electronic rights of way should accommodate increasing needs.
- i. Color and texture of finishes must be adaptable to student preferences.

### 2. Bathrooms

- a. Bathing should revolve around individual or small group needs, as in domestic bathrooms.
- b. Bathrooms should accommodate either sex without conversion.
- c. To reduce leaks, surfaces should present minimum joints and intersections.
- d. Bathroom fixture design should reflect function.
- e. Ventilation should control humidity, temperature, and odors. Provision for damp-storage should be included in the bathroom rather than in student's room.

- f. Provide facilities recognizing the use of student housekeeping in residence halls.

### 3. Dining Rooms

- a. Scale to occupant and provide divisions for small intimate groups.
- b. The dining room character should reflect its use for social and academic activities as well as for dining.
- c. Consider serving methods appropriate to the student's varied schedule.
- d. Attenuate sound, provide attractive furnishings and finishes, while permitting easy cleaning.
- e. Allow for student decoration.

### 4. Classrooms and Libraries

- a. Although the large lecture-classroom has requirements beyond the means of residence halls, smaller informal classes can be held in the residence hall.
- b. Academic communications must have terminal space in the residence, such as now used for TV rooms or music listening areas.

### 5. Services and Storage

- a. Services will become increasingly automated.
- b. Service areas requiring utilities should be easily accessible and grouped with bathrooms to minimize plumbing.
- c. Active storage should be provided for in student rooms.
- d. Inactive student storage should be provided in accessible areas.
- e. Trash, which will increase, must be easily disposable from the student room and the building.

### 6. Circulation and Interrelation of Spaces

- a. The progressive order of room, suite, group, house, college, and campus will continue.
- b. Larger communities will likely be the rule.
- c. Suite arrangements will increase in popularity.

- d. Corridors should be finished consistent with their usage.
- e. Elevators and access dimensions must accommodate handicapped occupants.

#### 7. Controls and Regulations

- a. Controls and regulations have a measurable impact on the occupants and the facilities when durability of material is stressed rather than appropriate total environment for the occupants.
- b. Facilities with acoustical control and adaptability require less administrative control.

#### 8. Adaptability

The residential building must be adaptable throughout its amortized life, in order to provide the required initial variety and adaptability to changing student mix, social evolution, affluence, and student identity.

#### 9. Operations

- a. Incentives for improved operations can be achieved in a sympathetic environment.
- b. Adaptability can lead to year-round occupancy.
- c. Environment should reflect a balance between maintenance and construction considerations.
- d. Maintenance obsolescence can be reduced by good design and by careful choice of material and equipment.
- e. Maintenance contracts from installers result in better quality installations.
- f. Functional (social and aesthetic) obsolescence can be offset through flexibility in planning, permitting adaptation to changing needs and tastes.

#### 10. Finance

- a. Construction costs must relate to maintenance cost and overall annual costs to students.
- b. Total costs must be reduced to provide for students of limited means.



## **APPENDICES**

## APPENDIX I

### SPACE UTILIZATION IN RESIDENCE HALLS UNIVERSITY OF CALIFORNIA

Seven recently constructed residence halls on various campuses illustrate the current distribution of spaces and functions. These are representative of several current approaches to planning and reflect philosophies and hierarchical structures varying from small two-story groupings to high-rise structures.

Each residence hall has been analyzed on the basis of space devoted to various functions in terms of square feet of building area per resident student. Floor plans of the residential floors are illustrated.

This analysis is derived from the University of California Space Study Survey, AE080-1A, Fall 1965.

## SPACE UTILIZATION IN RESIDENCE HALLS

Project Name	Berkeley		Davis		Los Angeles		Riverside		Santa Barbara		Irvine		Average
	R.H. 3	Ryerson	R.H. 5	Regan	R.H. 4	Hedrick	R.H. 4	Lothian	R.H. 2	Anacapa	R.H. 1	Mesa Ct. [8 bld'g]	
Total No. Student Spaces	840	204	390	848	414	418	384						
Number Double Rooms	420	102	140	424	198	203	192						
Number of Suites	-	-	24	-	-	-	-						
Number Single Rooms [Space Utilization]	-	-	14	-	18	12	-						
[In Square Feet Per Student]													
Living Quarters	87.0	80.0	88.4	85.0	85.3	88.6	75.0						84.2
Kitchen-Dining	27.8	-	-	16.6	14.4	-	-						19.6
Snack Space	.2	.2	.1	.9	.2	.7	.0						.4
Lounges	9.2	8.3	17.5	13.2	4.2	4.2	32.8						12.7
Library-Study	8.6	9.2	4.9	2.3	6.3	7.3	3.7						6.0
Recreation Rooms	5.6	-	-	4.9	-	6.4	13.2						4.3
Bathrooms	14.7	14.8	13.7	9.7	14.7	9.4	11.9						12.7
Student Storage Rooms	3.4	2.2	2.6	2.2	2.2	1.0	4.8						2.6
Student Laundry Rooms	2.5	3.7	2.3	1.4	1.0	.8	1.9						1.9
Administration	1.8	1.0	.5	2.2	2.5	1.0	.0						1.3
Custodial	9.2	1.0	1.5	3.9	4.1	2.1	.0						2.9
Staff Living Quarters	1.5	2.1	7.1	.7	2.7	2.2	7.4						3.3
Unassignable Space (circulation, stairs, elevators, stairs and construction)	75.4	*93.0	*59.0	88.0	79.3	*58.9	66.5						80.9 w/dining 69.4 w/o dining
Assignable Sq. Ft. Per Student	172.5	*122.5	*138.6	143.0	140.0	*123.7	*150.7						151.8 w/dining
Outside Gross Sq. Ft./Student	247.9	*215.5	*197.7	231.1	219.3	*182.6	*217.2						133.8 w/o dining 232.7 w/dining 203.2 w/o dining

\*No Dining Areas

APPENDIX II

**COST<sup>a</sup> PER STUDENT SPACE OF  
UNIVERSITY OF CALIFORNIA RESIDENCE HALLS (in \$1000)**

	Berkeley	Davis	Davis	Los Angeles	Riverside	Santa Barbara	Irvine
	Priestley	Ryerson	Regan	Hedrick	Lothian	Anacapa	Mesa Ct.
Total Building Cost	\$4,614	\$1,055	\$1,566	\$4,217	\$2,291	\$1,304	\$1,305
Group 2 and 3 Equipment <sup>b</sup>	471	88	221	288	176	138	201
Total Building and Furnishing Cost	5,085	1,143	1,787	4,505	2,467	1,442	1,506
Total Building Cost Per Student	5.4	5.2	4.0	5.0	5.5	3.1	3.4
Group 2 and 3 Equipment Cost Per Student	0.56	0.43	0.57	0.34	0.42	0.31	0.52
Total Building and Furnishing Cost Per Student	6.0	5.6	4.6	5.3	6.0	3.4	3.9
Total Building and Furnishing Cost Per Student, adjusted to January, 1966	7.3 <sup>c</sup>	6.9	5.4	6.5 <sup>c</sup>	7.3 <sup>c</sup>	4.4	4.3
Number of Resident Students	848	204	390	848	414	418	384
Assignable Square Feet	146,300	24,938	54,032	121,375	57,995	51,712	51,948
ENR Construction Cost Index at Bid Date (Jan, 1966 equals 1050)	854.5	854.0	899.0	854.2	855.0	743.5	948.1

<sup>a</sup>Source of data is University of California Space Survey Study, AE080-1A, Fall 1965; and Office of Architects and Engineers Cost Data Sheets.

<sup>b</sup>This includes room furnishings, but excludes dining hall kitchen equipment and mechanical equipment generally under general construction contract.

<sup>c</sup>Includes dining facilities.

# APPENDIX III HIERARCHICAL PATTERNS IN U.C. RESIDENCE HALLS

CAMPUS - HALL

BERKELEY UNIT #1  
 DAVIS - RYERSON  
 DAVIS - REGAN  
 L.A. - RIEBER  
 RIVERSIDE - LOTHIAN  
 SANTA BARBARA - ANACAPA  
 IRVING - MESA CT  
 RIVERSIDE - ABERDEEN  
 SANTA BARBARA - SAN NICHOLAS  
 SAN TIEGO - REVELL  
 SANTA CRUZ - COWELL  
 SANTA CRUZ - TRAILERS  
 BERKELEY - STERN

## APPENDIX III

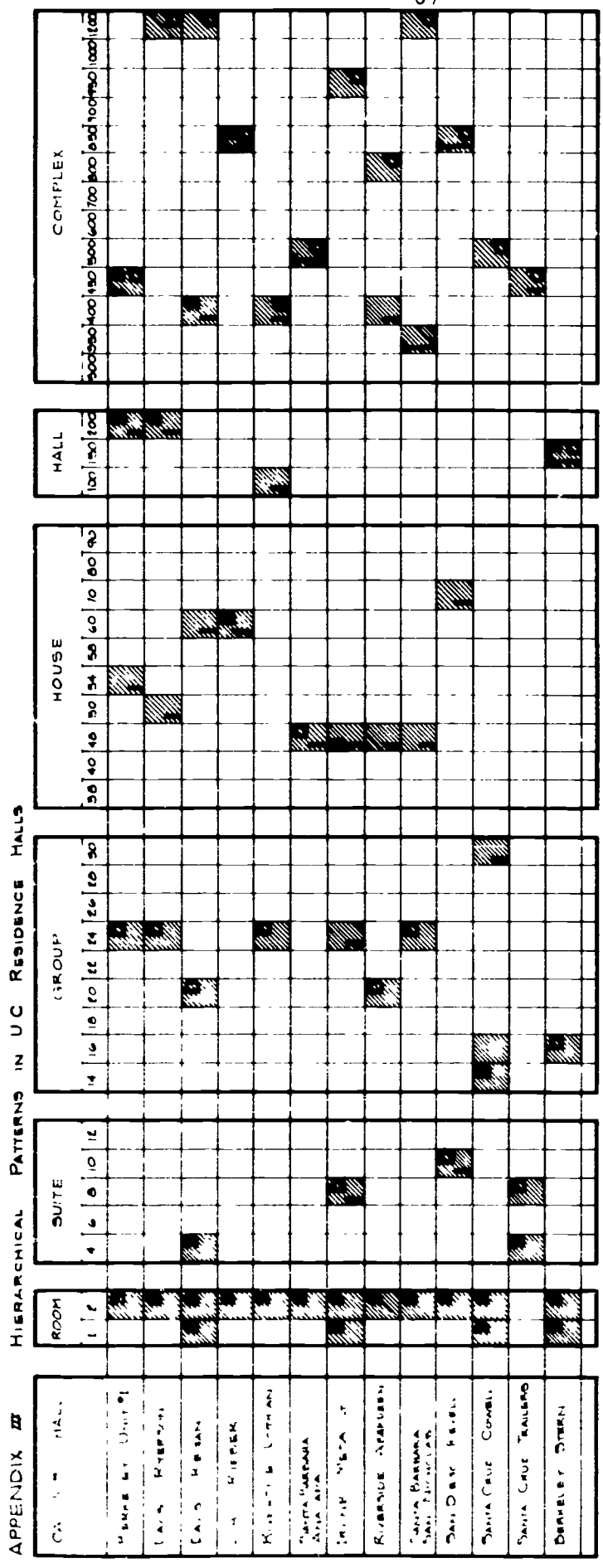

s STUDY  
 b BATH  
 r RECREATION  
 i LOUNGE  
 d DINING



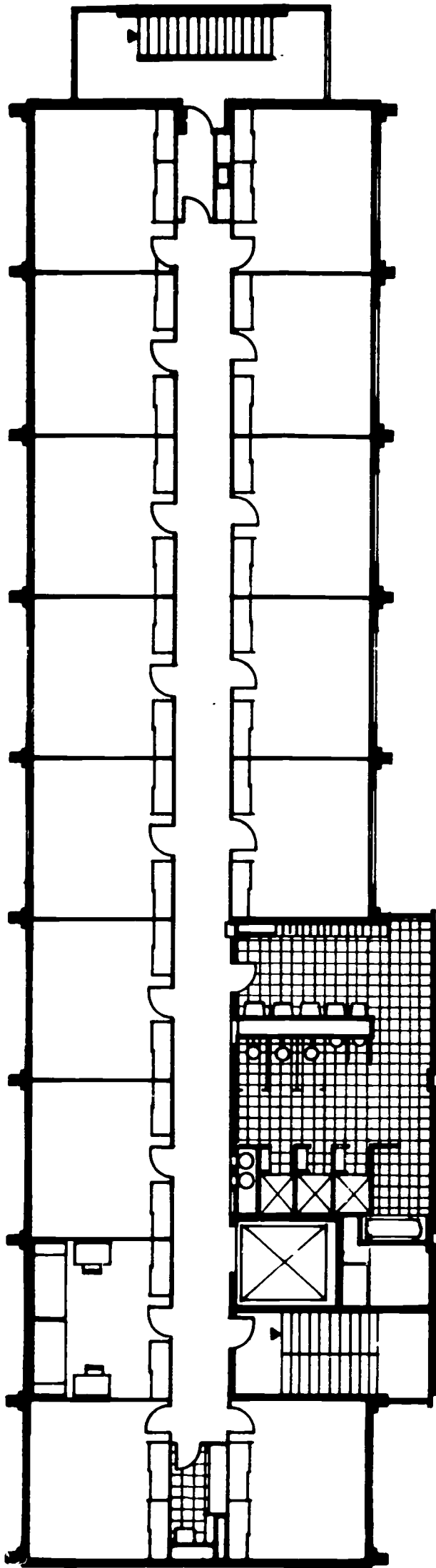

TYPICAL RESIDENCE FLOOR PLAN

Residence Hall #3, Priestly Hall, BERKELEY

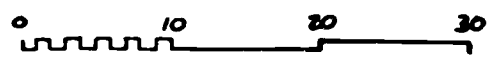



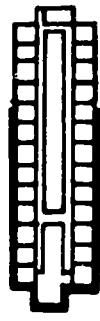
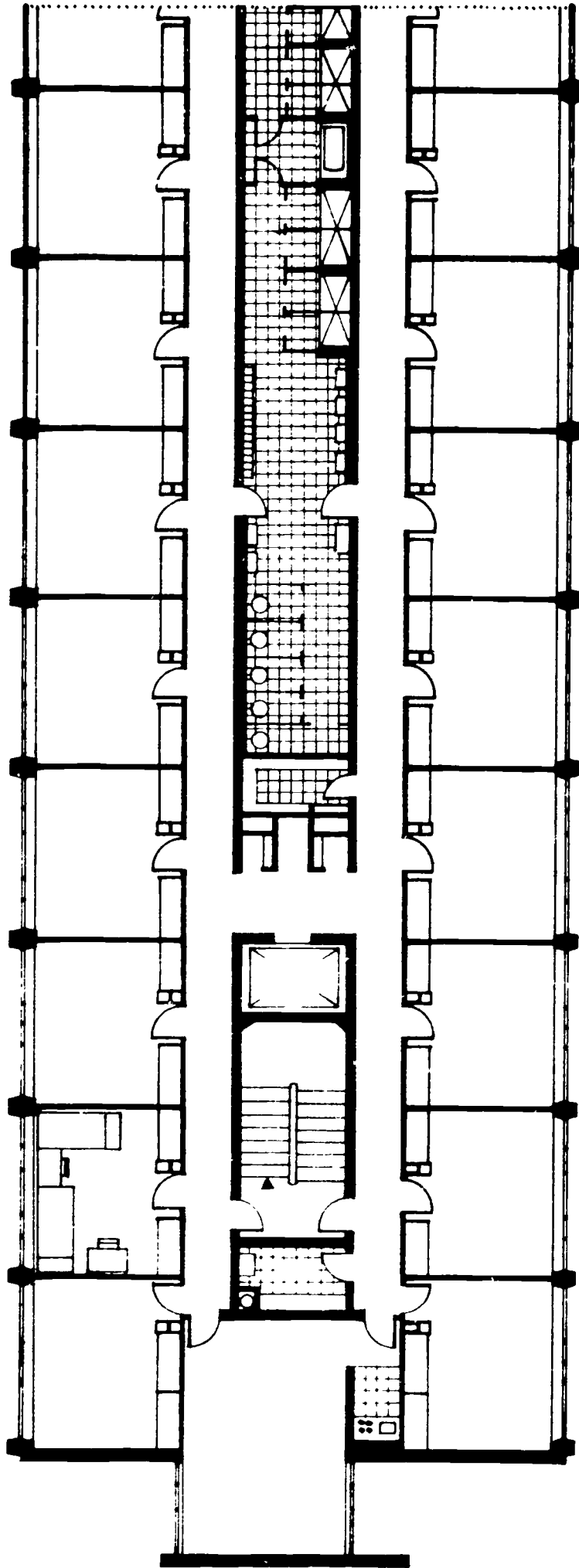

TYPICAL RESIDENCE FLOOR PLAN

Residence Hall #5, Ryerson Hall, DAVIS



[plate 21]

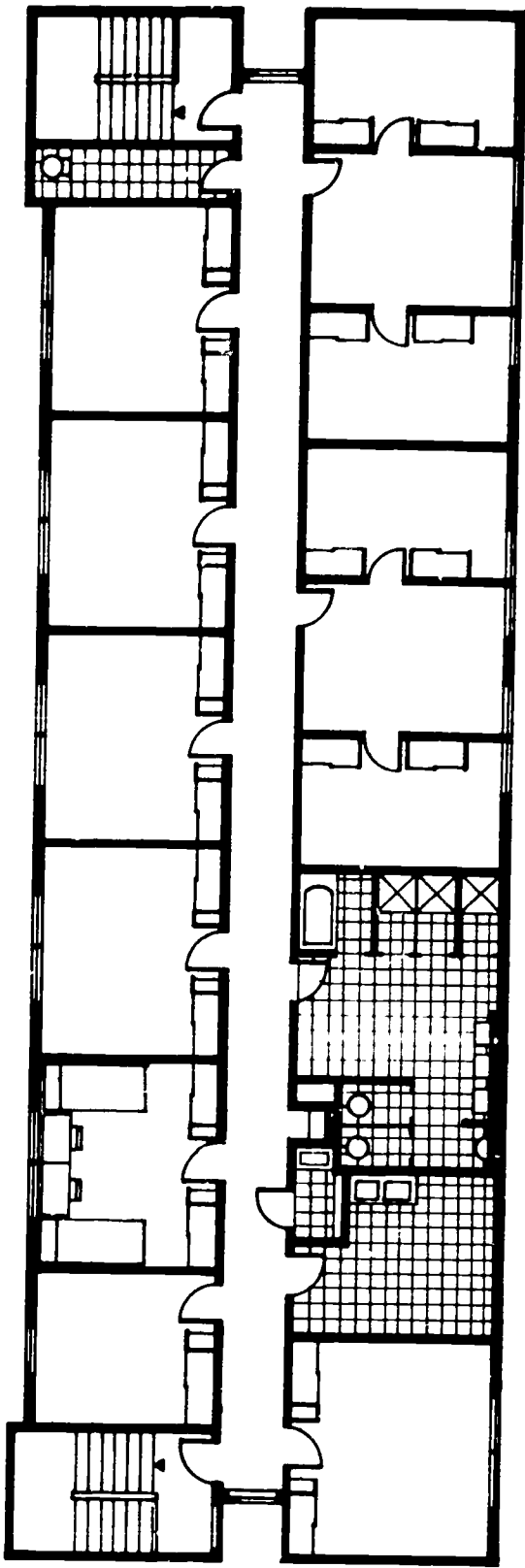

TYPICAL RESIDENCE FLOOR PLAN

Residence Hall #6, Regan Hall, DAVIS

[plate 22]



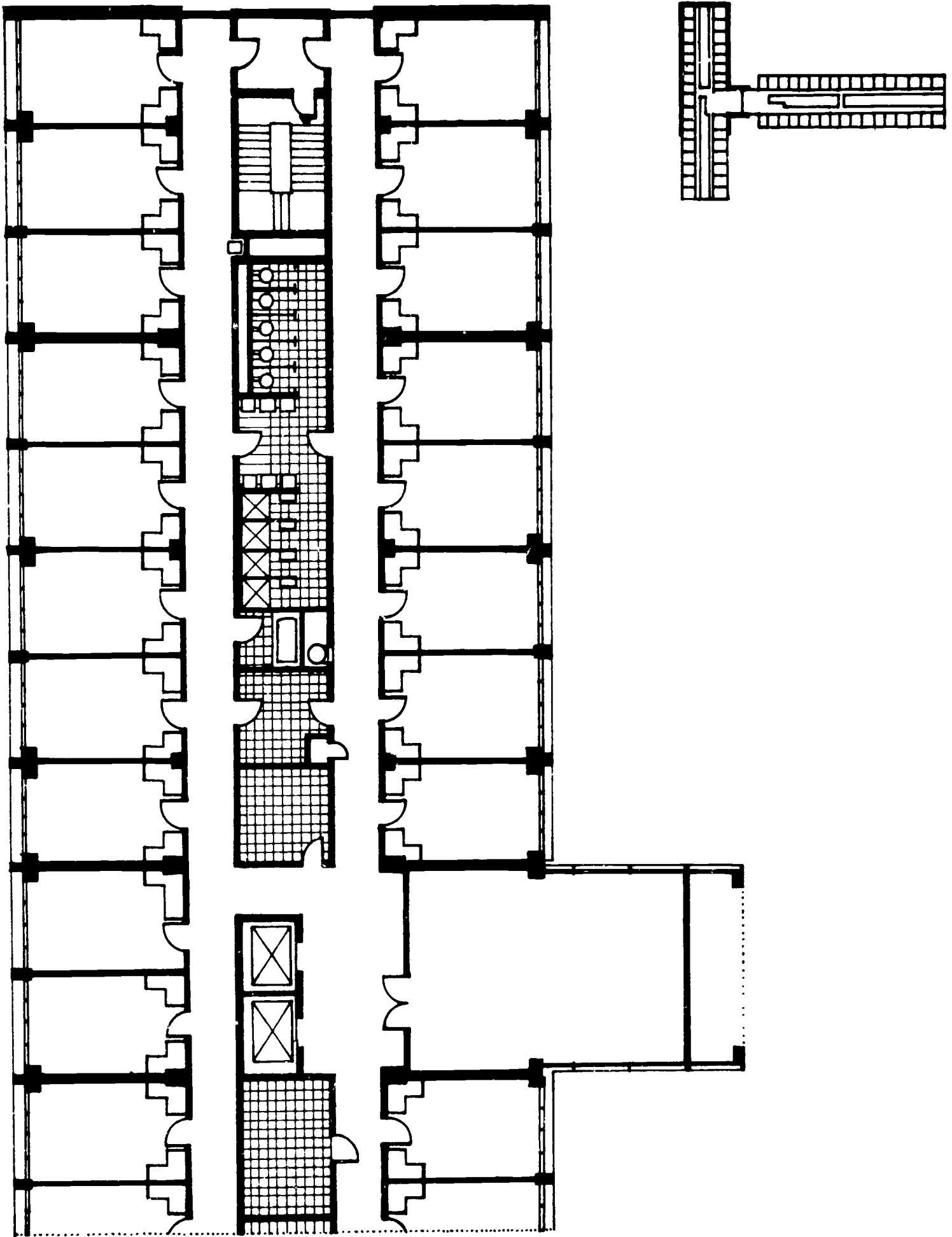

Residence Hall #3, Hedrick Hall, LOS ANGELES

[plate 23]



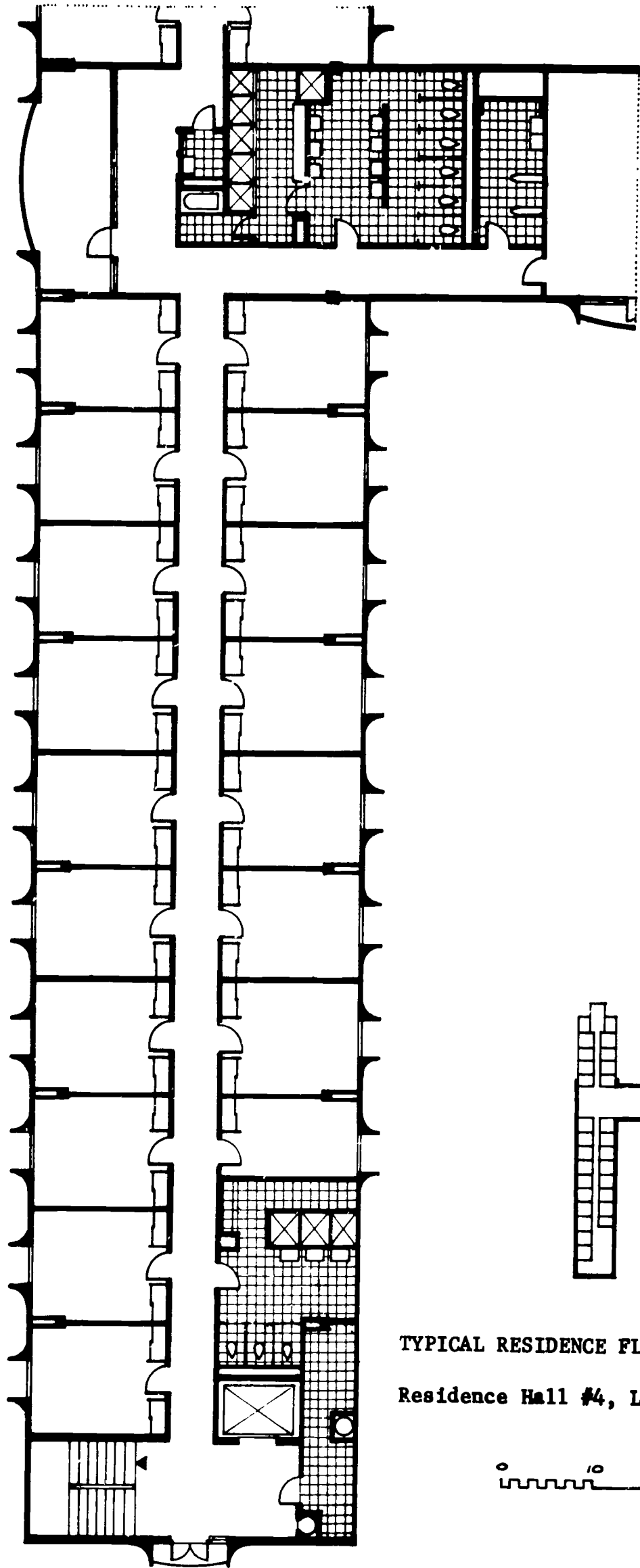

TYPICAL RESIDENCE FLOOR PLAN

Residence Hall #4, Lothian Hall, RIVERSIDE



[plate 24]

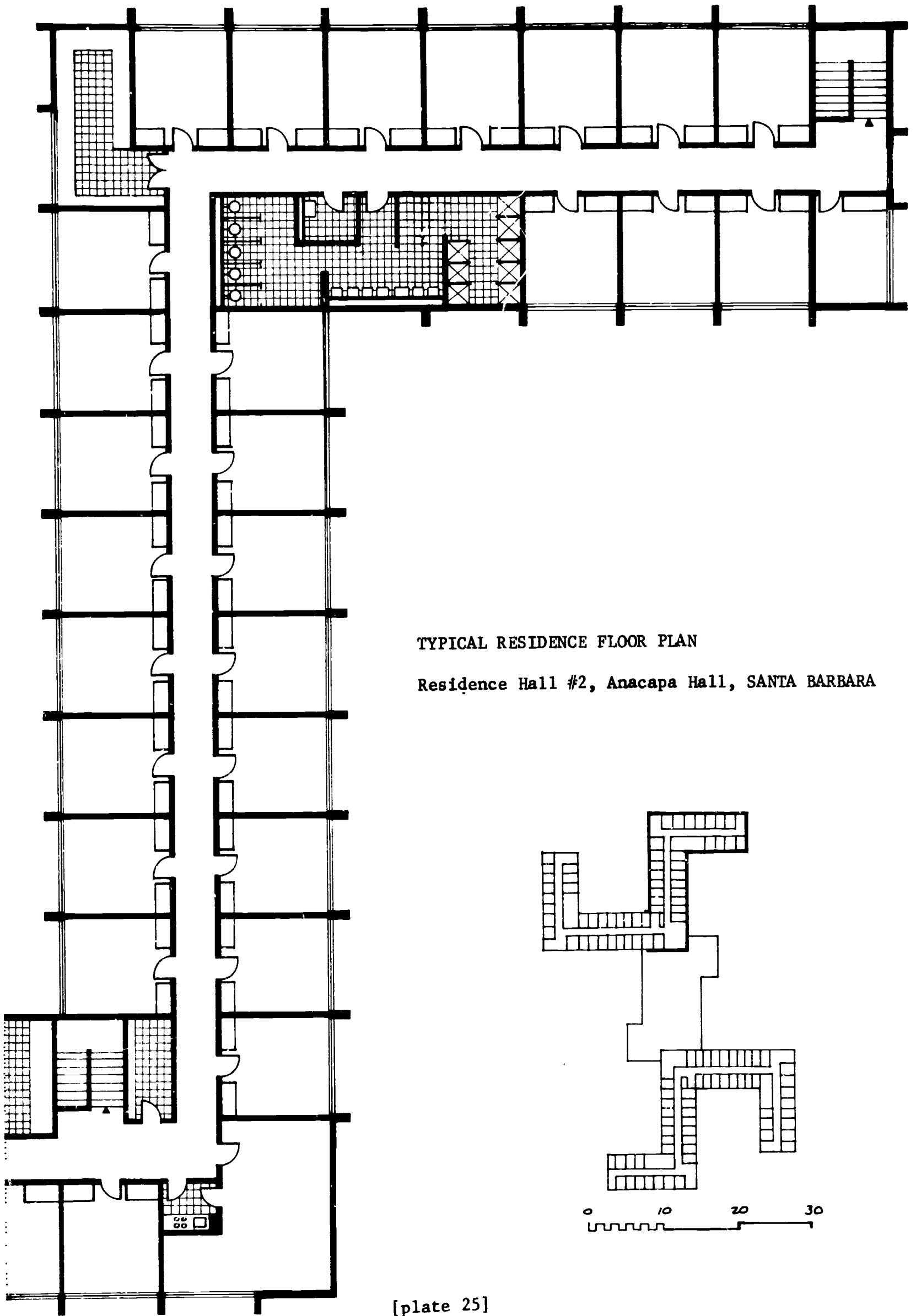

TYPICAL RESIDENCE FLOOR PLAN

Residence Hall #2, Anacapa Hall, SANTA BARBARA

[plate 25]

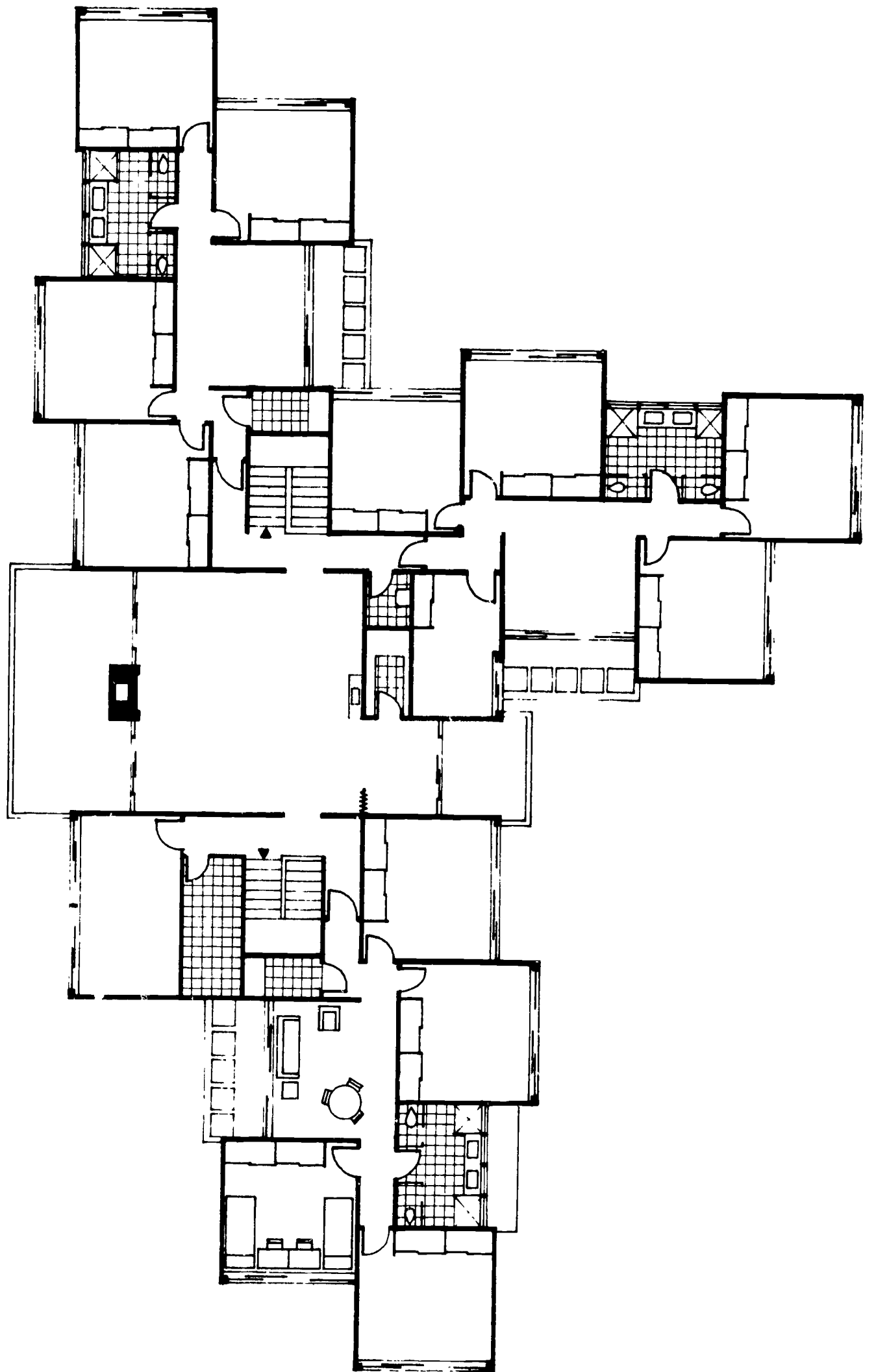

TYPICAL RESIDENCE FLOOR PLAN

Residence Hall #1, Mesa Court, IRVINE

[plate 26]





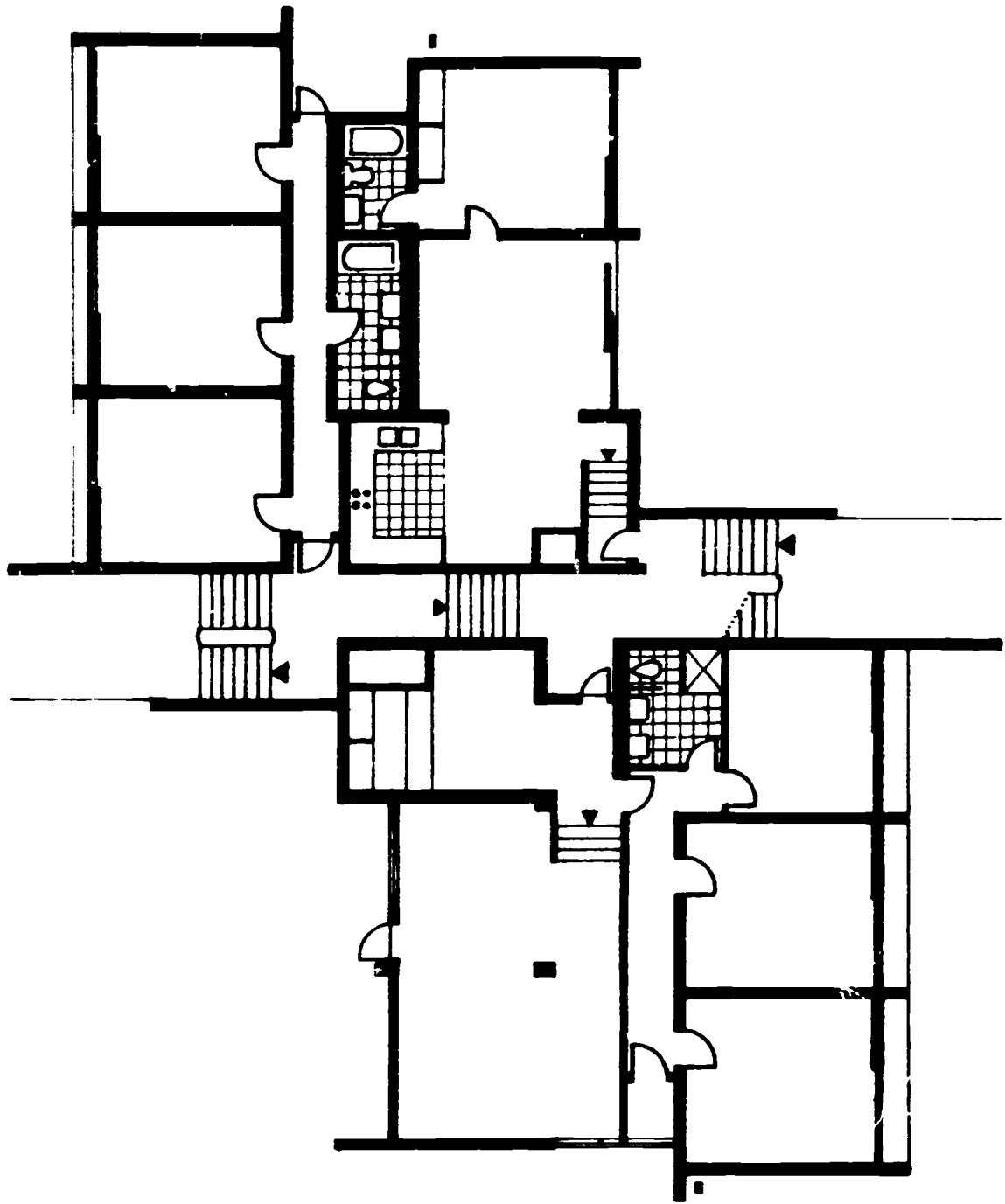

Residence Hall #1, Reville Hall, SAN DIEGO  
[Lower Floor Plan]

[plate 27]



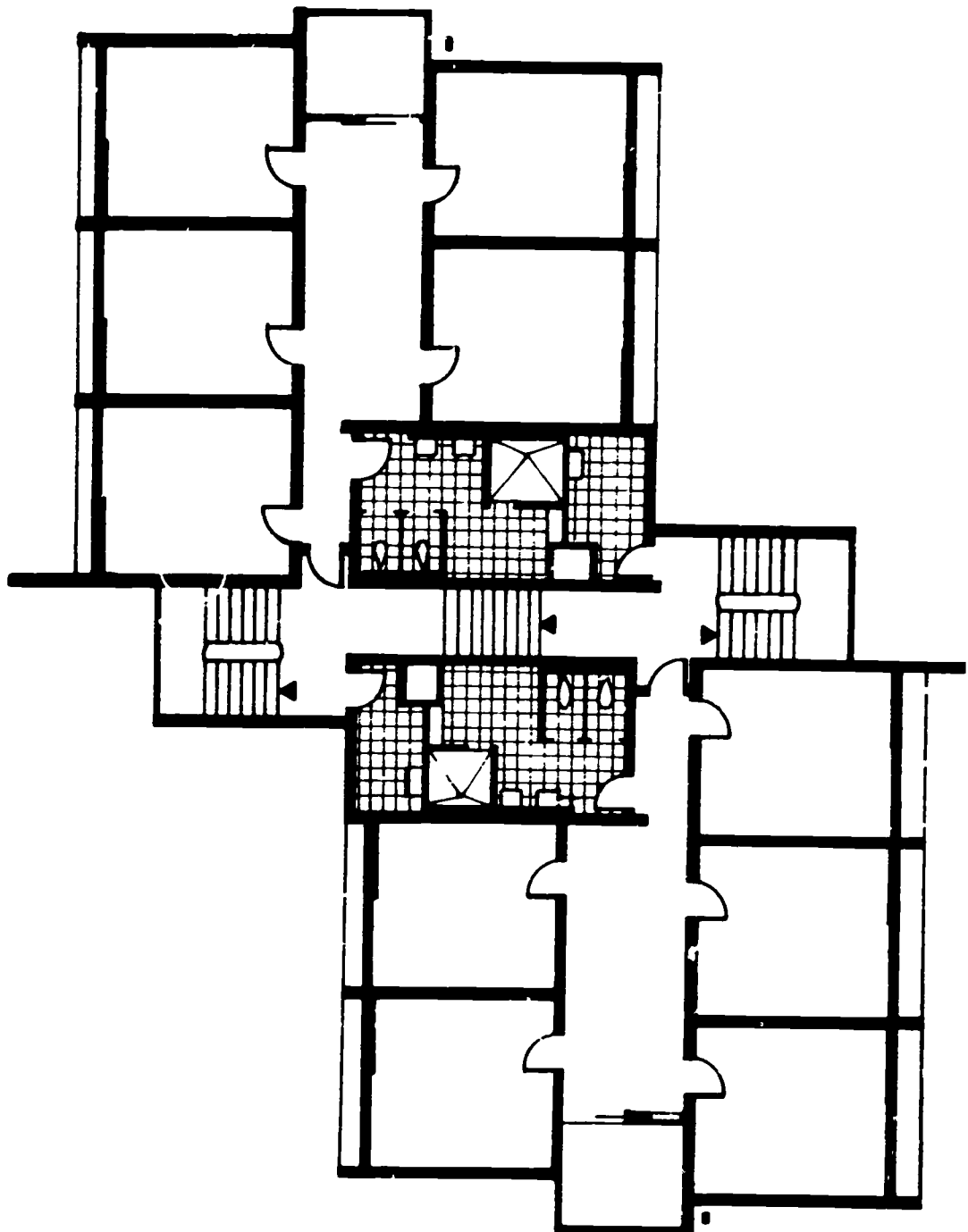

Residence Hall #1, Reville Hall, SAN DIEGO  
[Upper Floor Plan]

[plate 28]



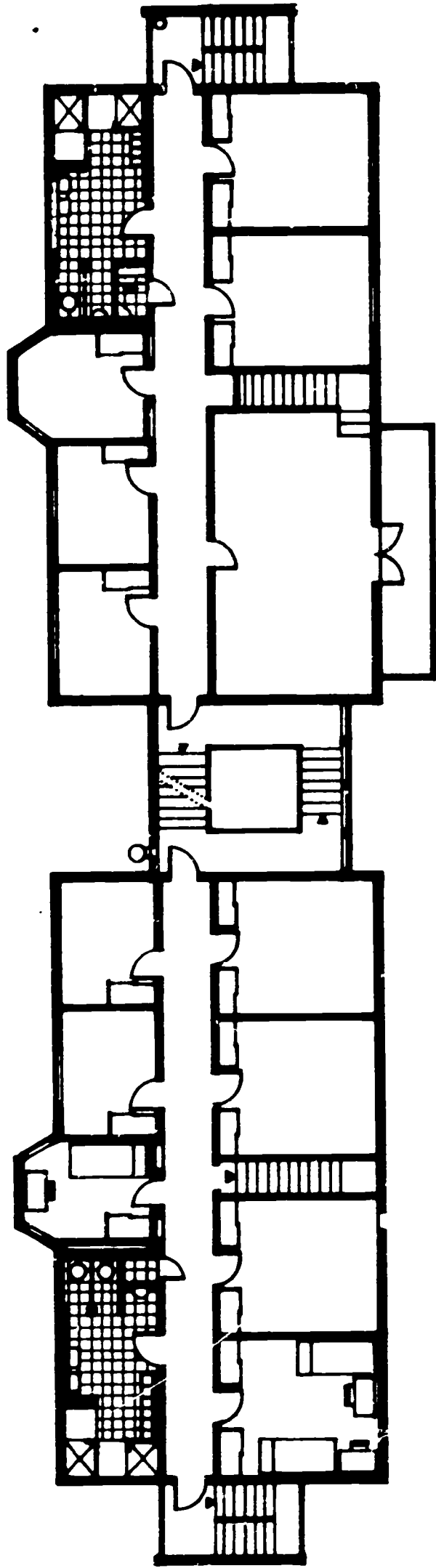

**TYPICAL RESIDENCE FLOOR PLAN**

**Residence College #1, Cowell College, SANTA CRUZ**

[plate 29]



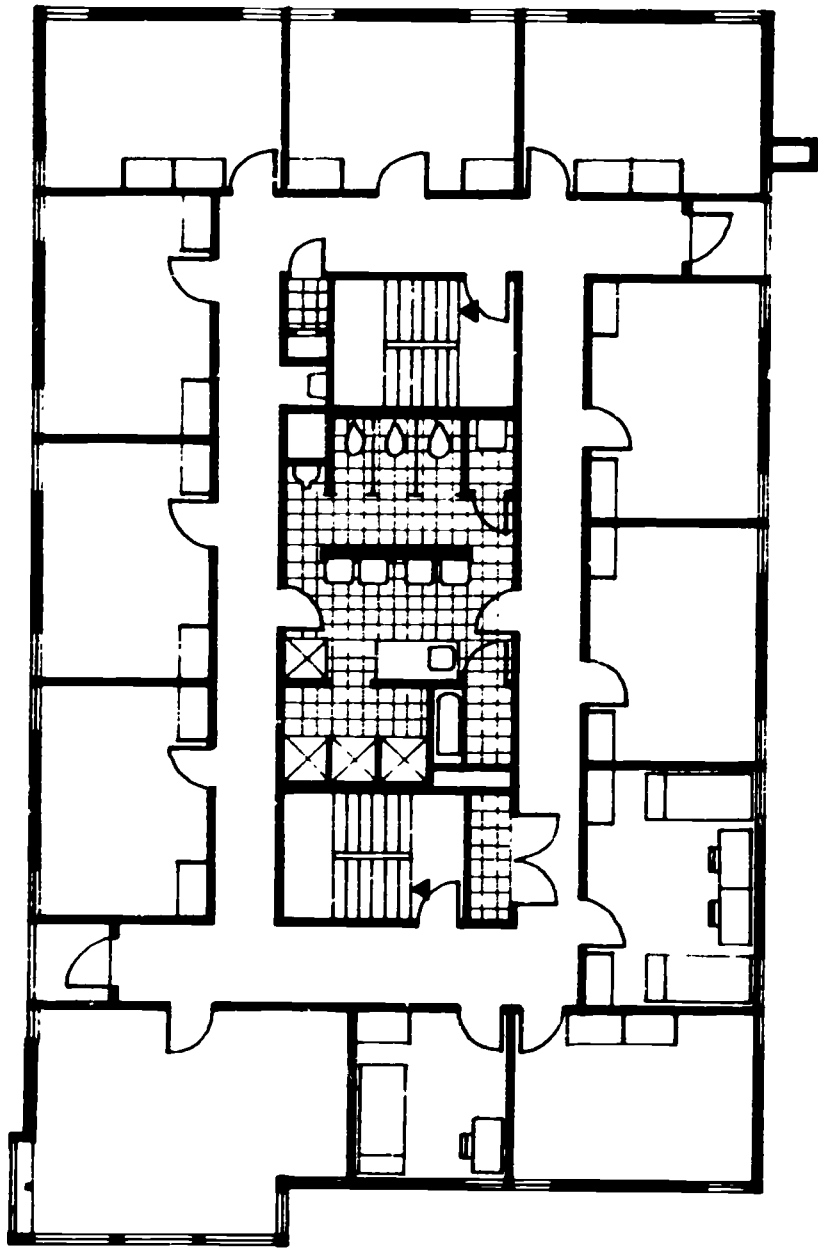

Residence Hall #2, Stevenson College, SANTA CRUZ

[plate 30]



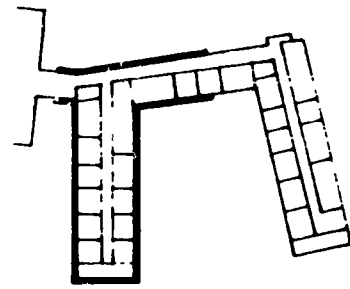
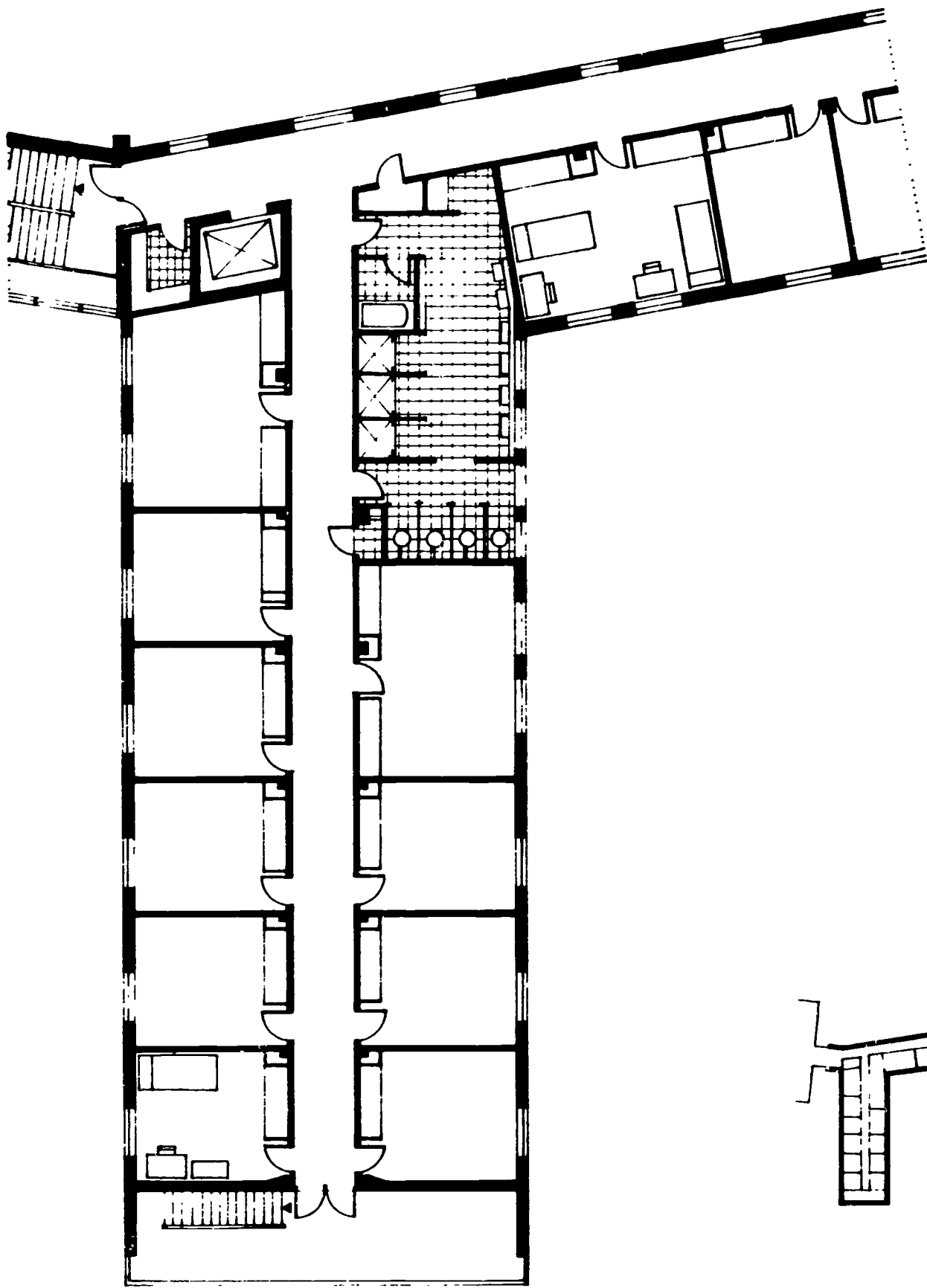

Stern Hall, BERKELEY

[plate 31]



97 and 98

## APPENDIX IV

### AREA REQUIREMENTS FOR STUDENT ROOM FURNITURE

#### A. INTRODUCTION

1. Furniture sizes and use spaces are the average for existing furnishings.
2. Each furniture layout assumes the item(s) placed along a wall.

#### B. DESIGNATIONS

An item of furniture automatically requires additional space around it to make its use possible. This space should be in the planning of the room.

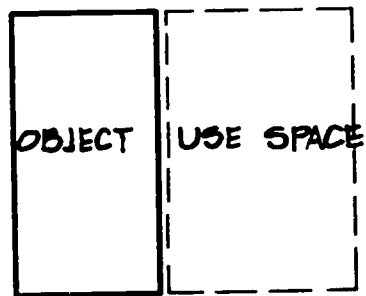

#### C. AREA REQUIREMENTS

Item

Bed

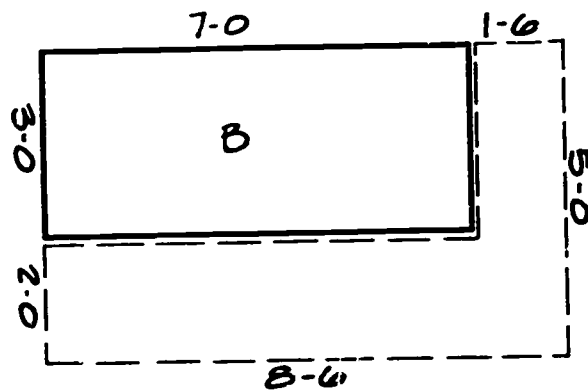

Desk

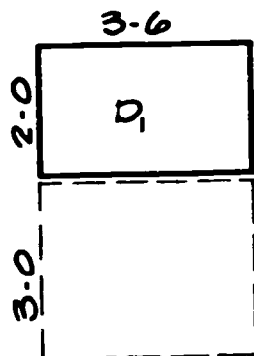



Desk

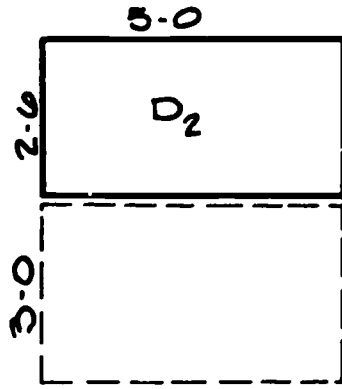

Wardrobe

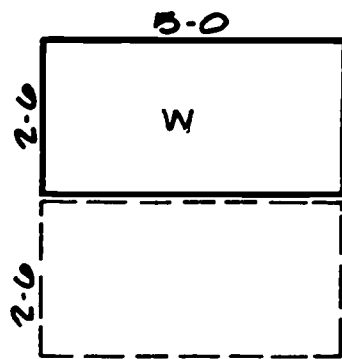

Door

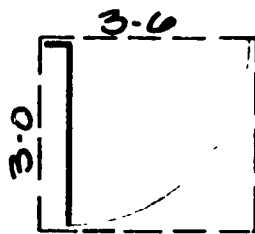

Soft Chair

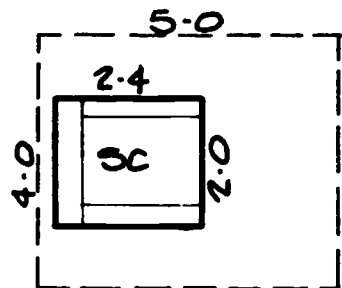

Bookcases

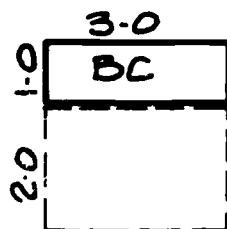

#### D. USE SPACE

The use space of one item may overlap the use space of another, but no use space should overlap an adjacent item of furniture.

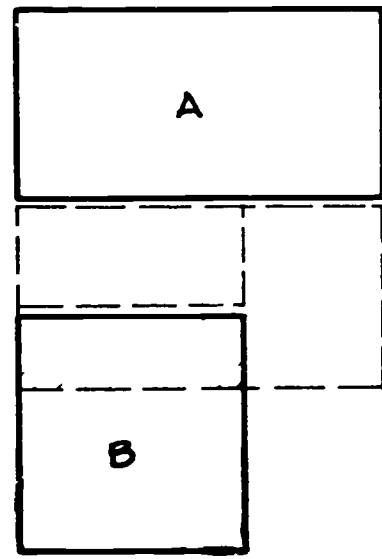
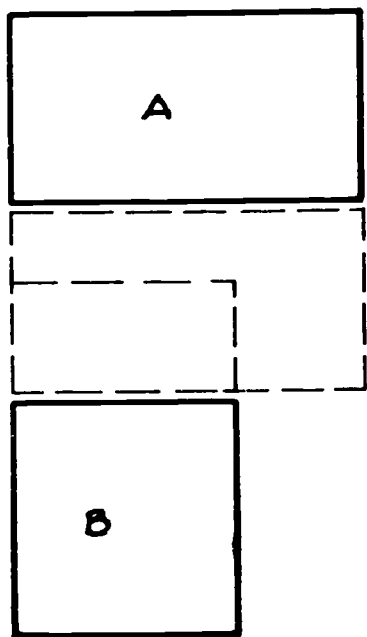

#### E. EXAMPLES OF FURNITURE LAYOUTS

The following illustrations depict some of the possible arrangements involved in the planning of the student room.

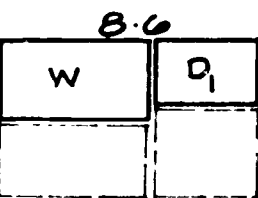
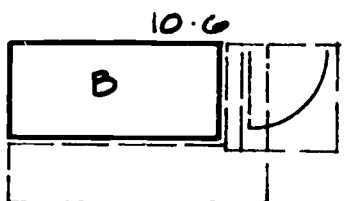
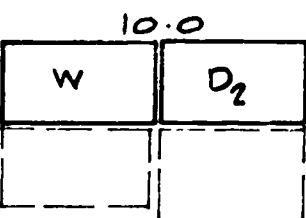
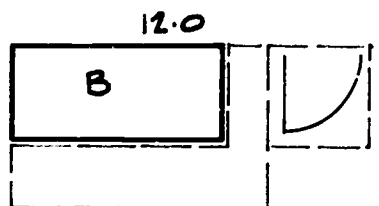
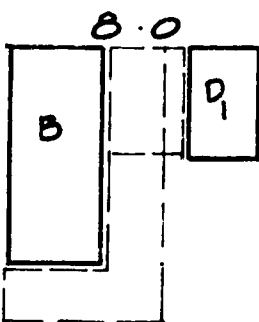
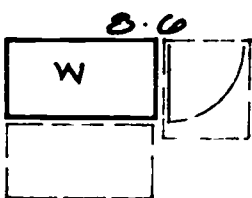
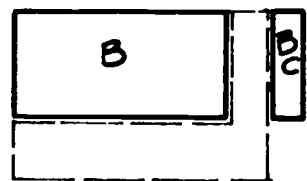
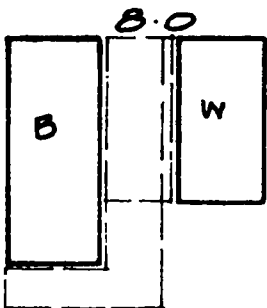
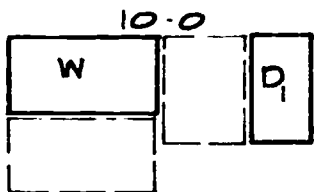
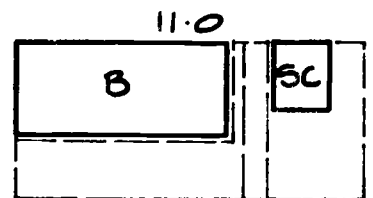
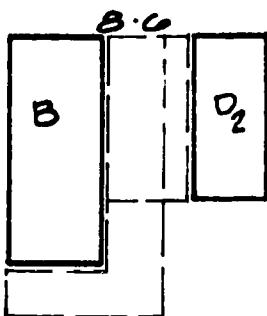
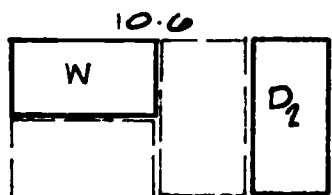
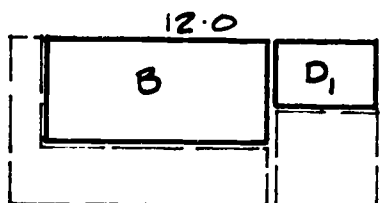
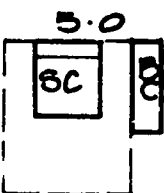
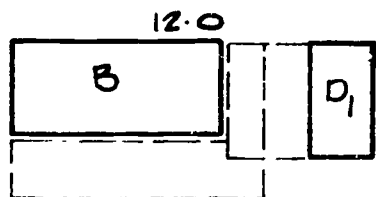
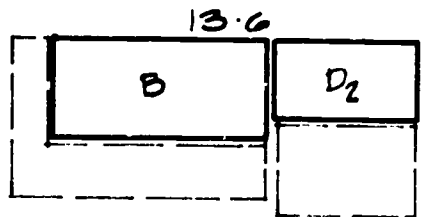
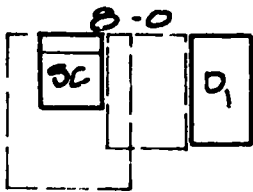
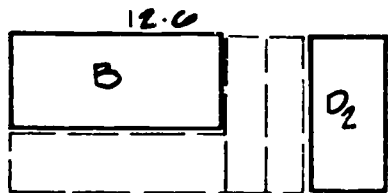
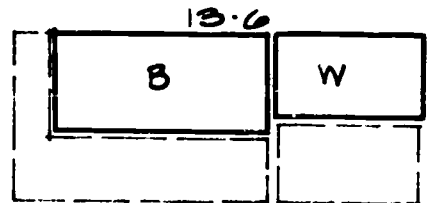
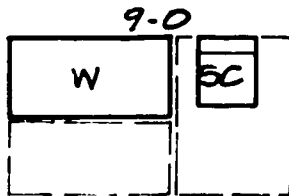
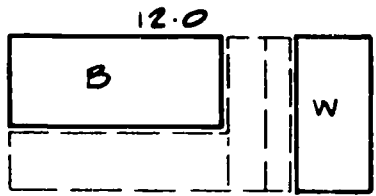

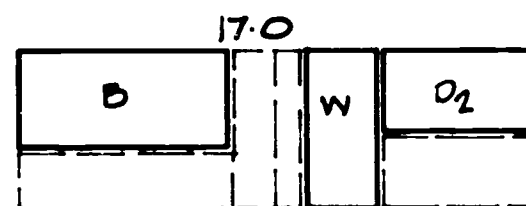
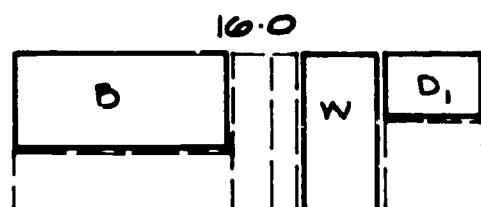
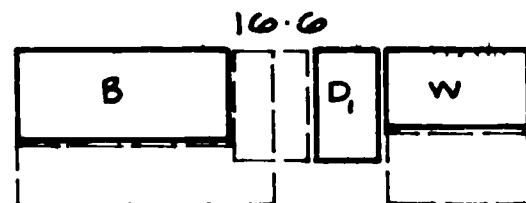
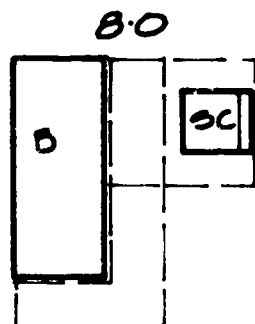
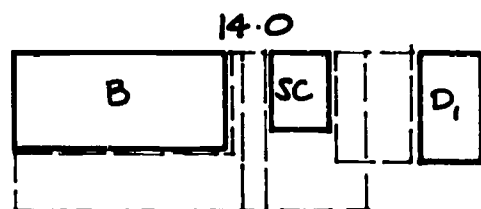
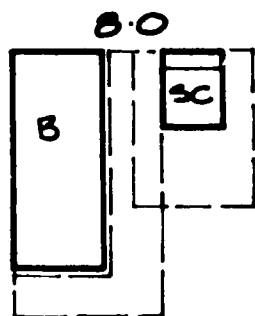
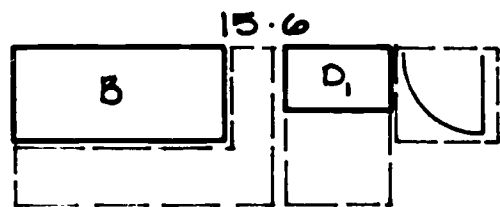
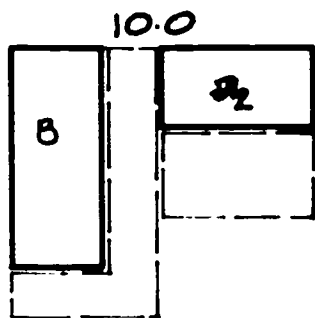
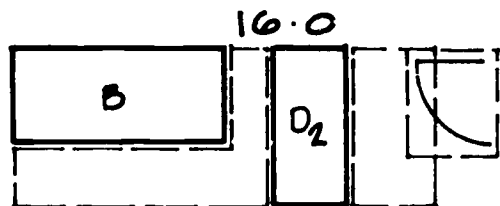
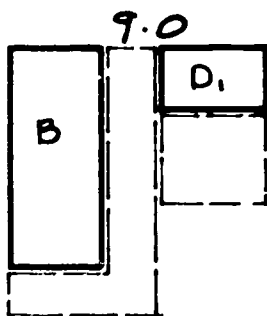
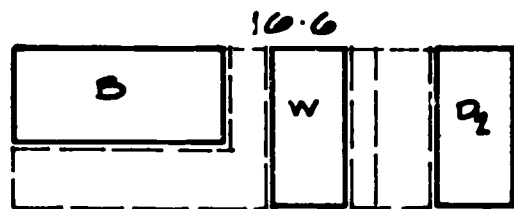
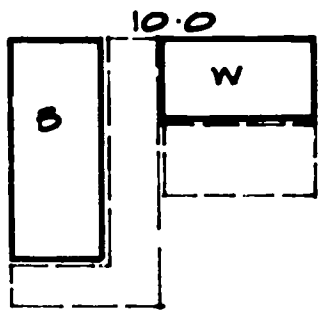

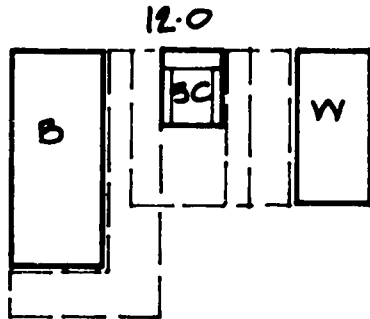
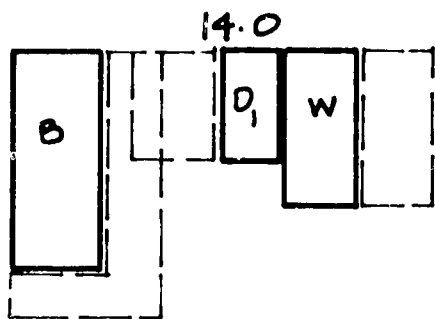
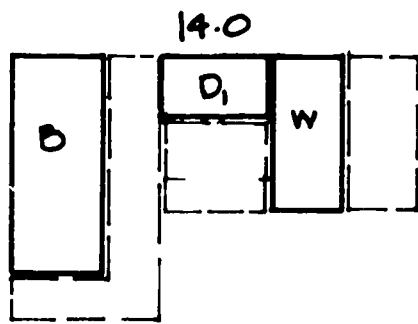
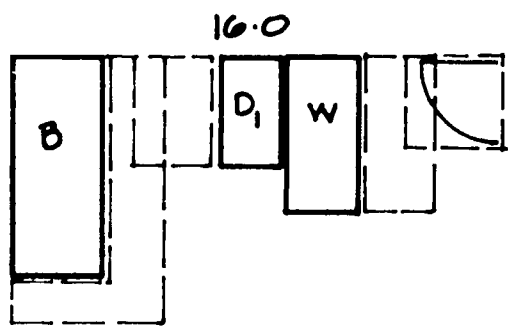
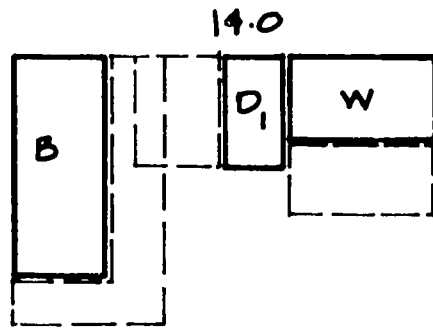
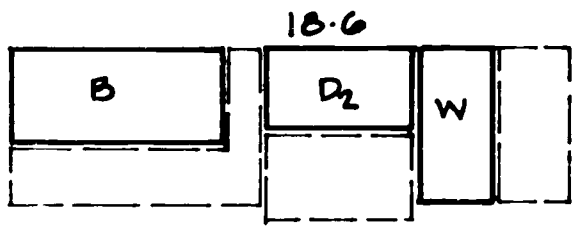
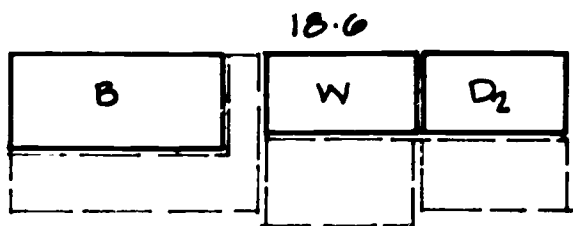
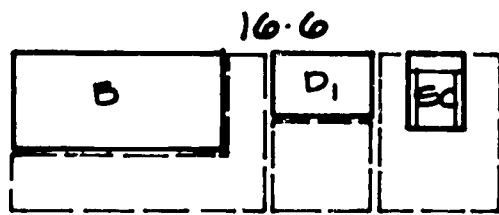
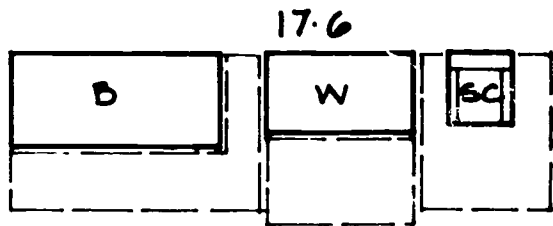
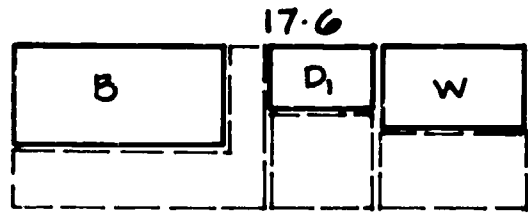
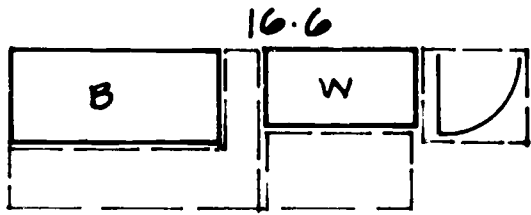

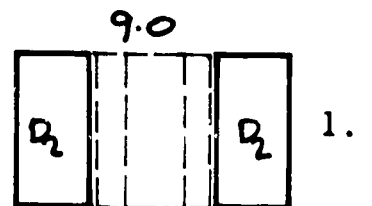
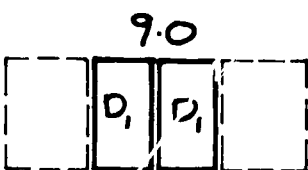
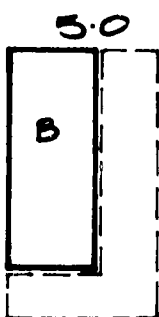
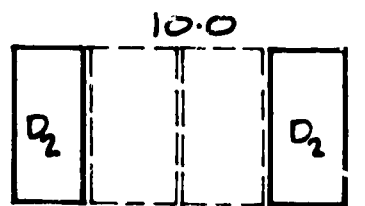
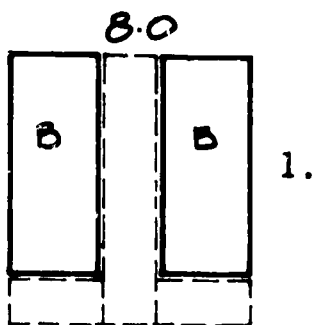
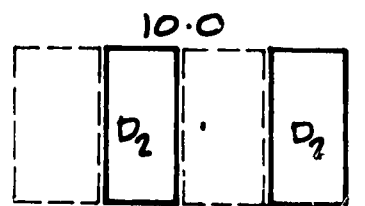
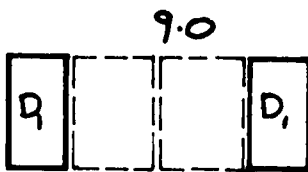
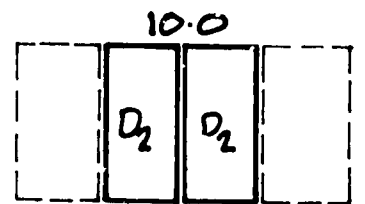
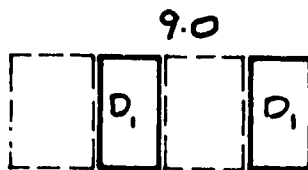
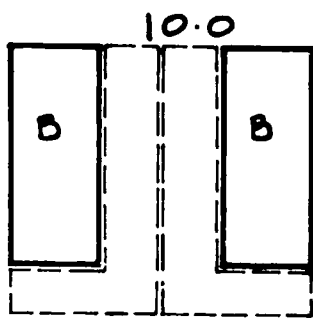
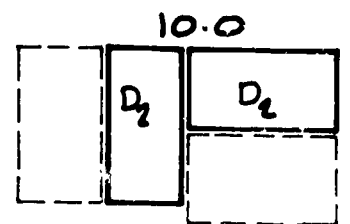
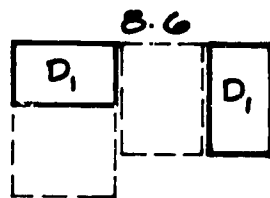
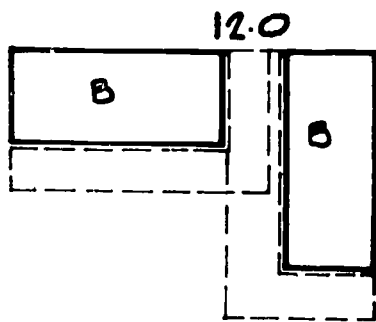
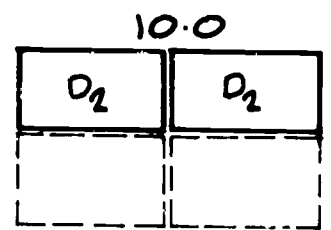
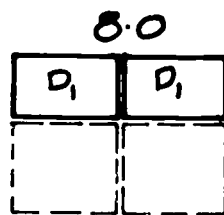
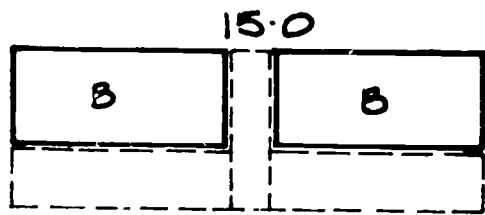



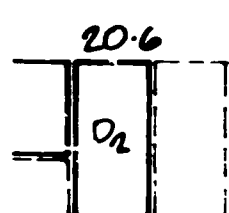
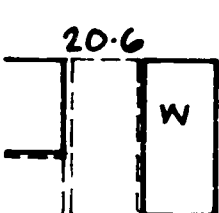
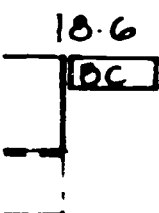
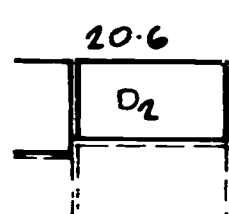
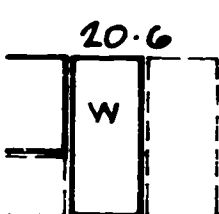
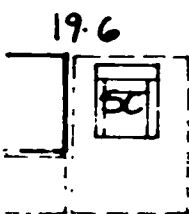
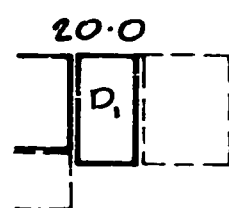
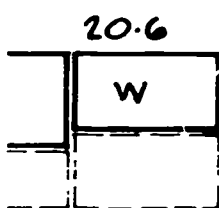
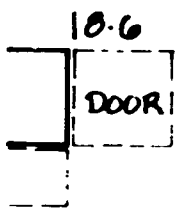
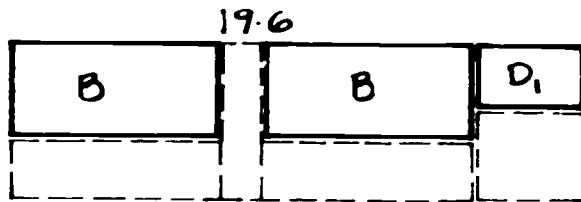
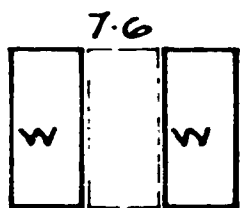
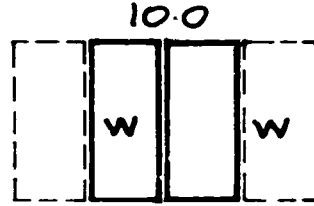
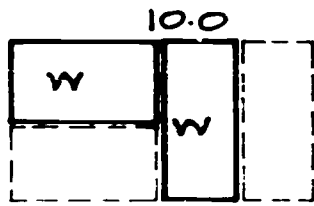
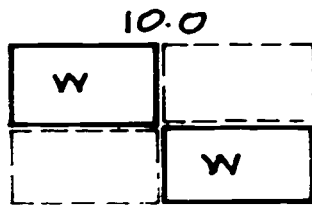
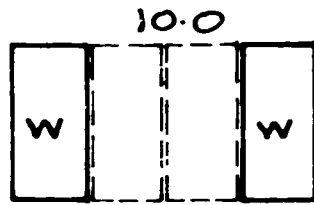
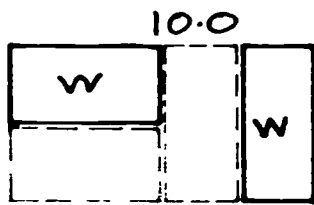
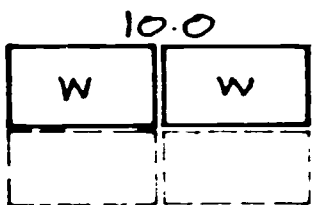

## APPENDIX V

### PLANNING STUDIES—SINGLE AND DOUBLE ROOMS

#### A. GENERAL

1. Room dimensions must accommodate:
  - a. Furniture sizes and design (wall mounted, free standing).
  - b. Furniture use spaces.
  - c. Combination of furniture items.
2. Room size (and shape) will affect two levels of possible room change:
  - a. Adaptability of furniture arrangements.
  - b. Divisibility of spaces—physical or visual separation of activities.

#### B. ROOM AREAS

1. Definition of terms used:
  - a. *Minimum*—access to furniture items; overlap of items and use space; some restriction in the use of furniture.
  - b. *Optimum*—no overlap of items and use space.
  - c. *Generous*—beginning of space divisibility.
2. Single Rooms
  - a. Minimum recommended area — 90 sq. ft.
  - b. Optimum recommended area — 110 sq. ft.
  - c. Generous recommended area — 120 sq. ft.
3. Double rooms with bunked beds
  - a. Minimum recommended area — 140 sq. ft.
  - b. Optimum recommended area — 160 sq. ft.
  - c. Generous recommended area — 180 sq. ft.

4. Double rooms without bunked beds
  - a. Minimum recommended area – 180 sq. ft.
  - b. Optimum recommended area – 220 sq. ft.
  - c. Generous recommended area – 240 sq. ft.

C. DIAGRAMMATIC ARRANGEMENTS—RECTANGULAR ROOMS

1. Single rooms

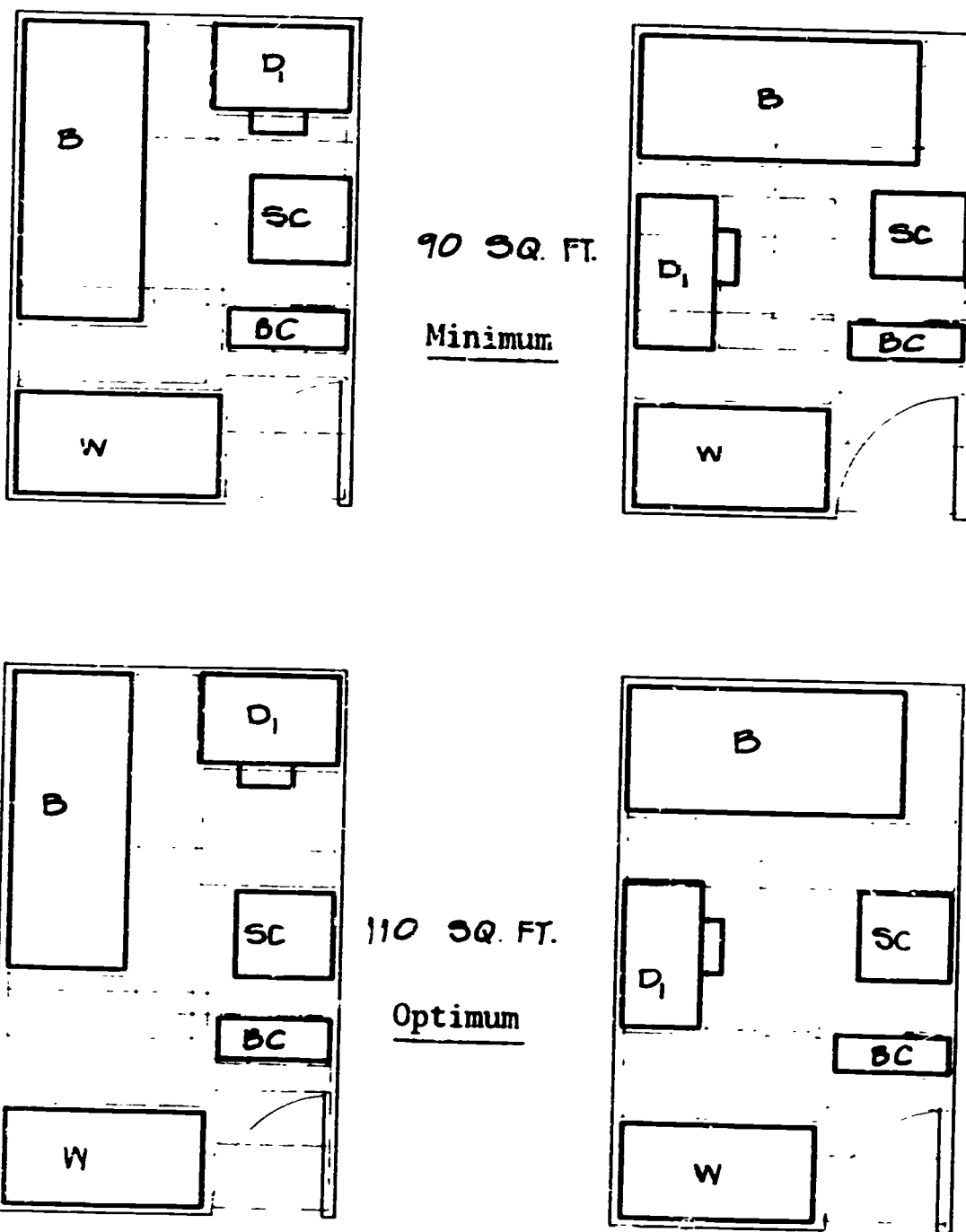

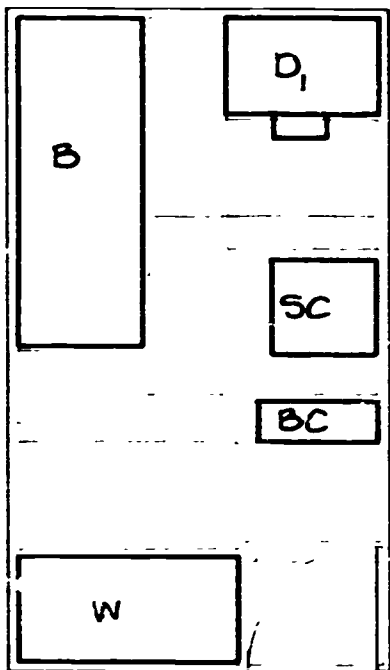

120 SQ. FT.

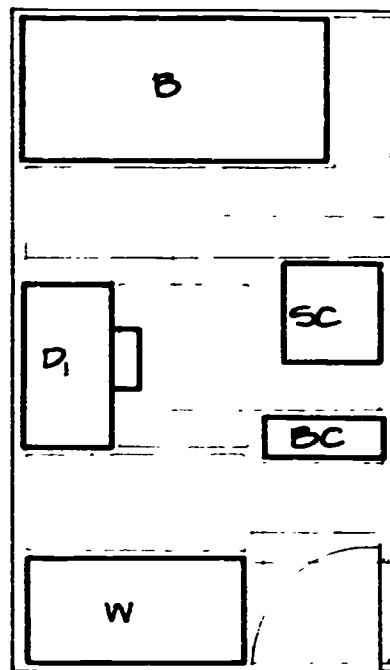

2. Double rooms  
bunked beds

non-bunked beds

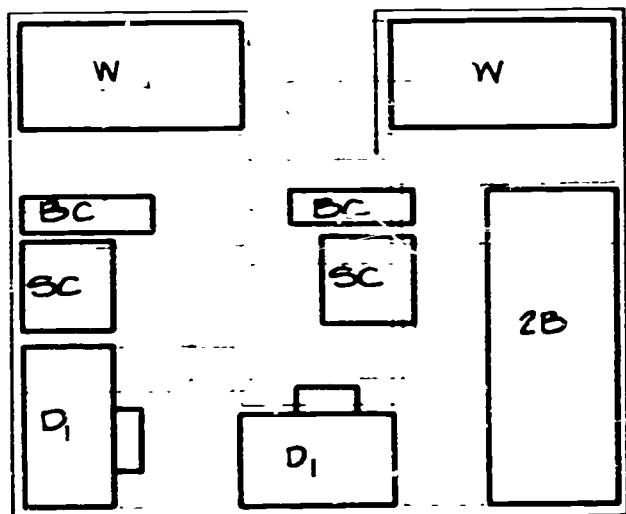

140 SQ. FT.

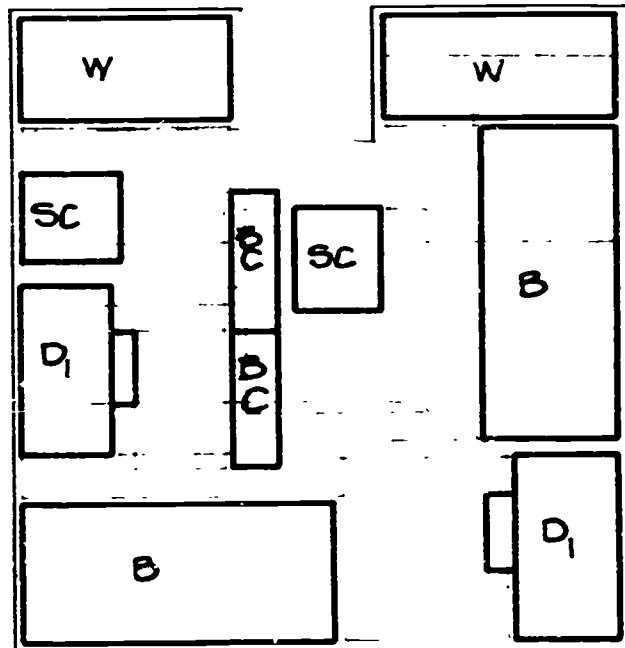

180 SQ. FT.

bunked beds

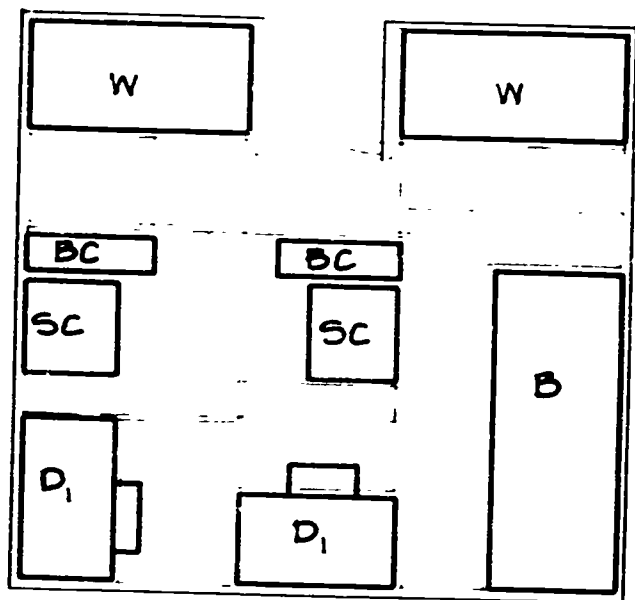

160 SQ. FT.

Optimum

non-bunked beds

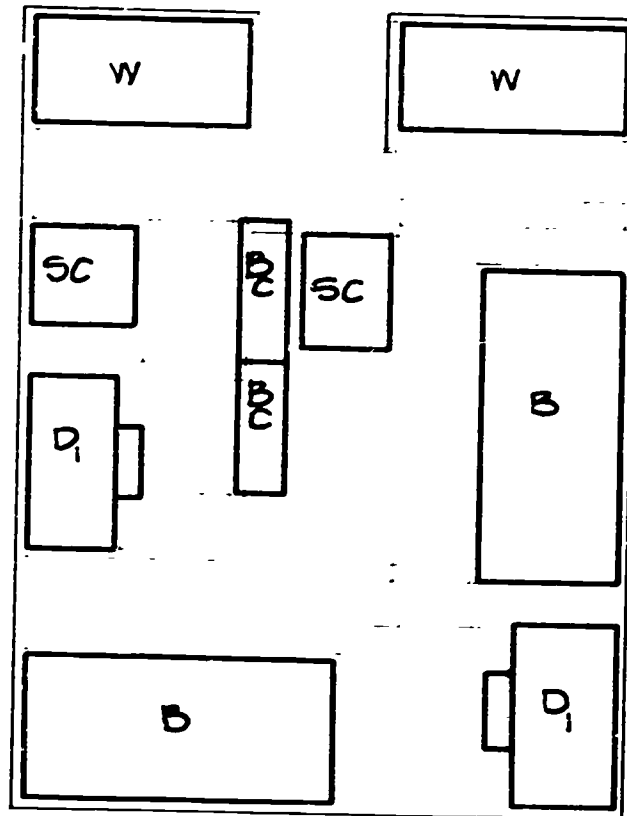

220 SQ. FT.

bunked beds

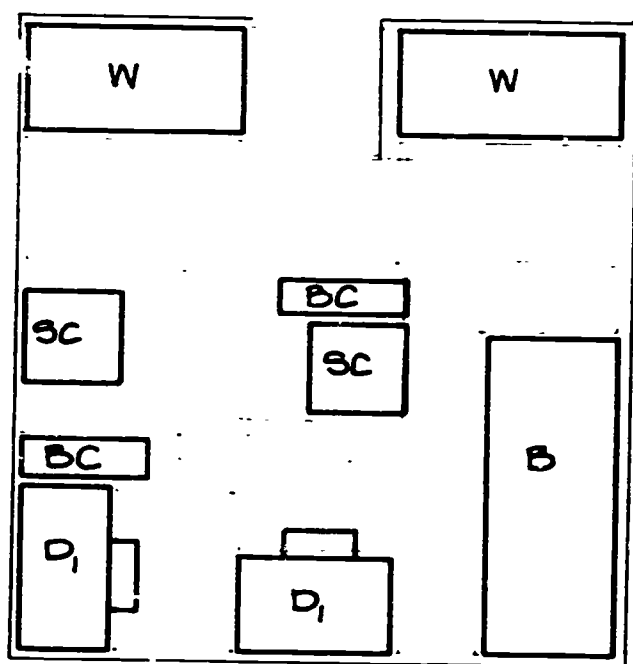

180 SQ. FT.

Generous

non-bunked beds

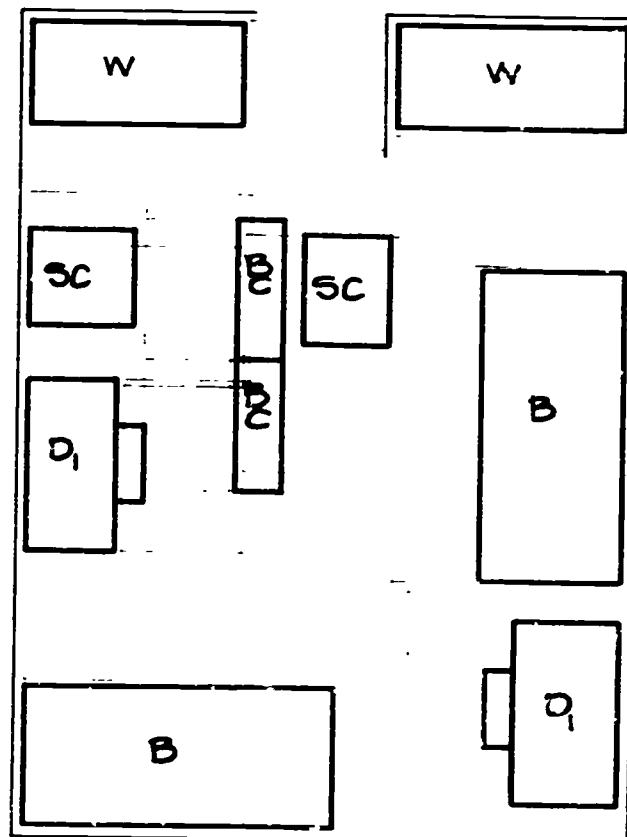

240 SQ. FT.

## APPENDIX VI

### PLANNING STUDIES—OFFSET AND NON—RECTILINEAR SINGLE ROOMS

#### A. OFFSET SINGLE ROOMS

##### 1. Conclusions

- a. The area of the room with an offset may be comparable to a rectangular room with little or no loss in the adaptability of furniture.
- b. If dimensions of the room and furniture sizes share a common module, an offset room may have a slightly greater amount of furniture adaptability than a rectangular room of equal area.
- c. In an offset room, the controlling object is the bed in determining the proportional areas of the two sections of the room. If it is desirable to move the bed from one section to the other, the two sections will be approximately equal in size. If it is not desirable, the interchangeability of other pieces of furniture will control the dimensions and size of each section of the room.



- d. An offset room will increase the possibility of space divisibility. In a rectangular room, the items must create the space; in an offset room the walls divide the space.

##### 2. Relationship of Furniture Adaptability and Floor Area

- a. The same furniture sizes as those used in Appendix IV have been assumed for wardrobe (W), bed (B), desk ( $D_1$ ), soft chair (SC), bookcase (BC) and door ( $D_0$ ).
- b. An offset room is used in which different items of furniture are combined in one space or exchangeable with furniture in another.

c. The bed is assumed to be non-exchangeable with furniture in the second space of the room.

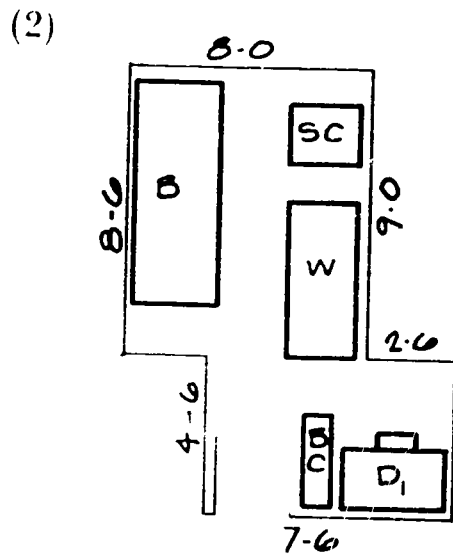
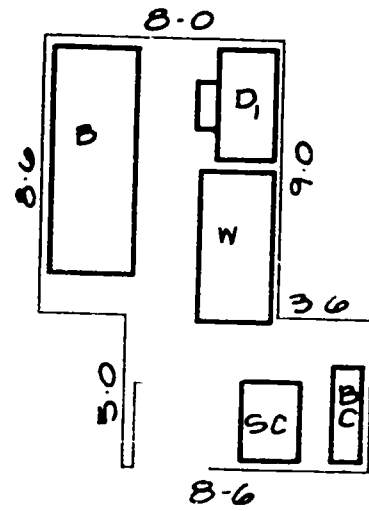
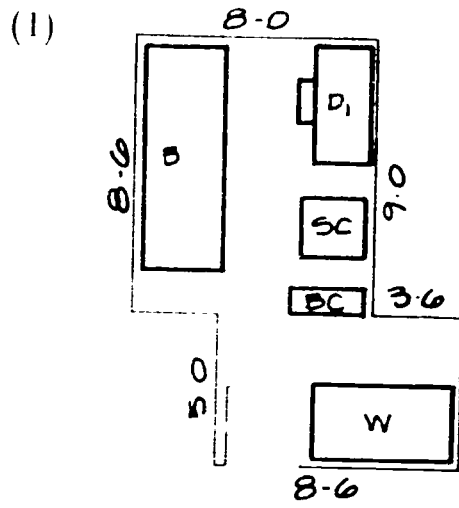

As the adaptability of furniture arrangements increases, the dimensional requirements of the room change.

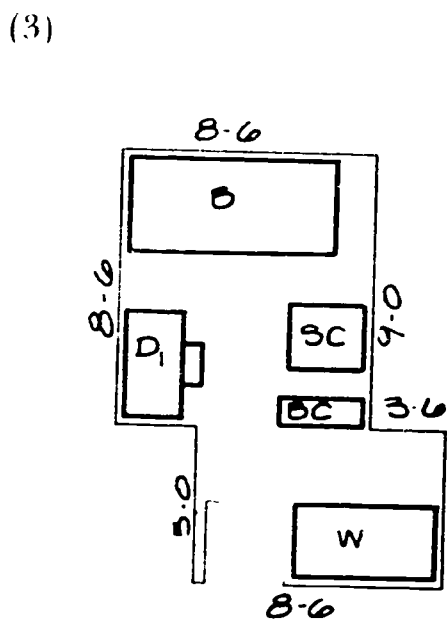



- (4) In combining the dimensional requirements of (1), (2), and (3), the resulting room area is 116.5 square feet.

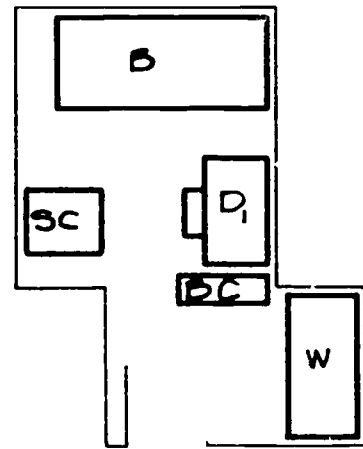
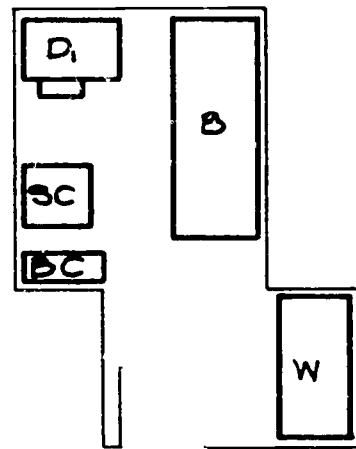
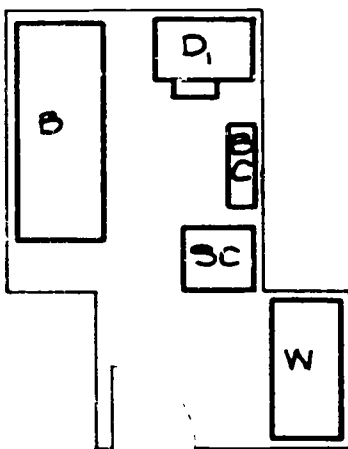
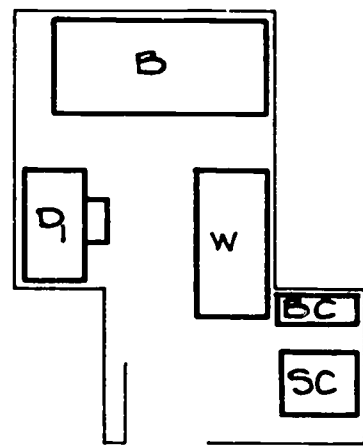
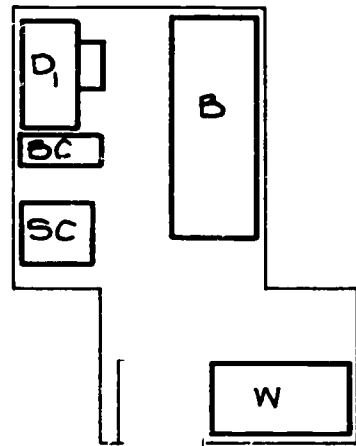
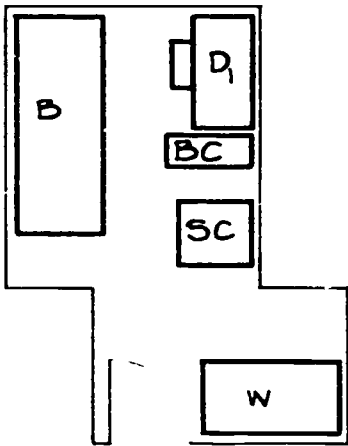
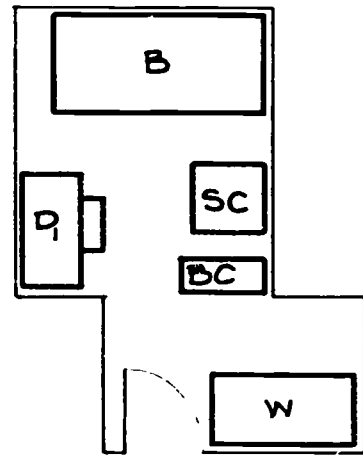
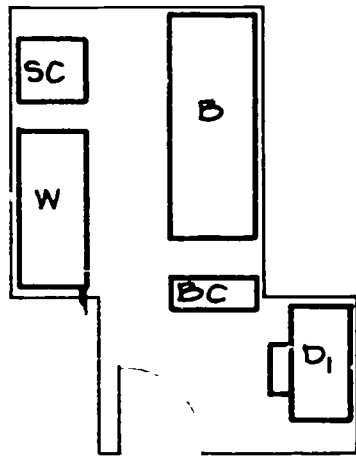
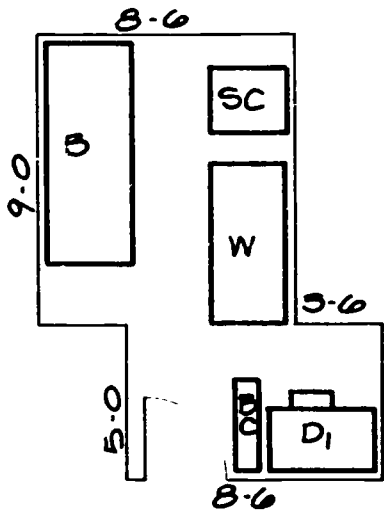

- d. In an optimum rectangular room of 110 sq. ft. (Appendix IV), a certain degree of furniture adaptability is possible. In an offset room of identical area, at least the same degree of adaptability is possible.

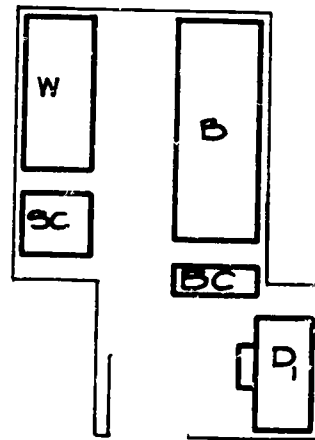
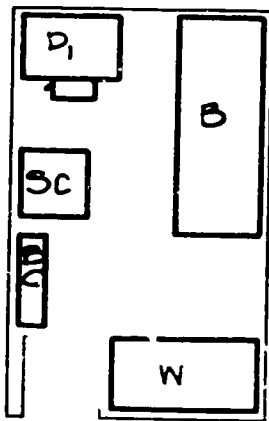
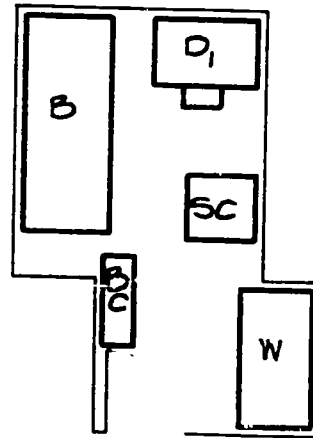
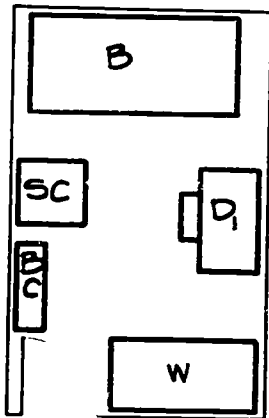
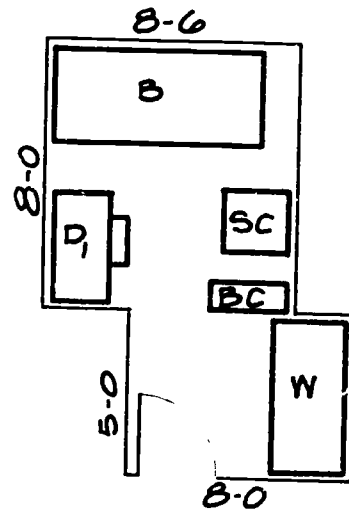
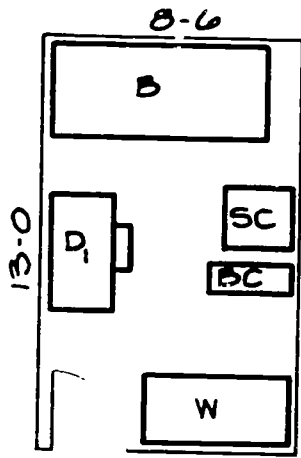

## B. SINGLE ROOMS WITH TWO OR MORE ADJACENT NON-PERPENDICULAR WALLS

### 1. Conclusions

- a. Rooms with at least two adjacent non-perpendicular walls tend to be larger than rectilinear rooms with similar furniture arrangements. Furniture sizes used are the same as in Appendix IV. There is a minimum area between any two items for use space. This space must remain the same no matter what position the objects assume with respect to each other. Thus, two objects at an odd angle to one another consume more space than they do when aligned in a rectilinear pattern.

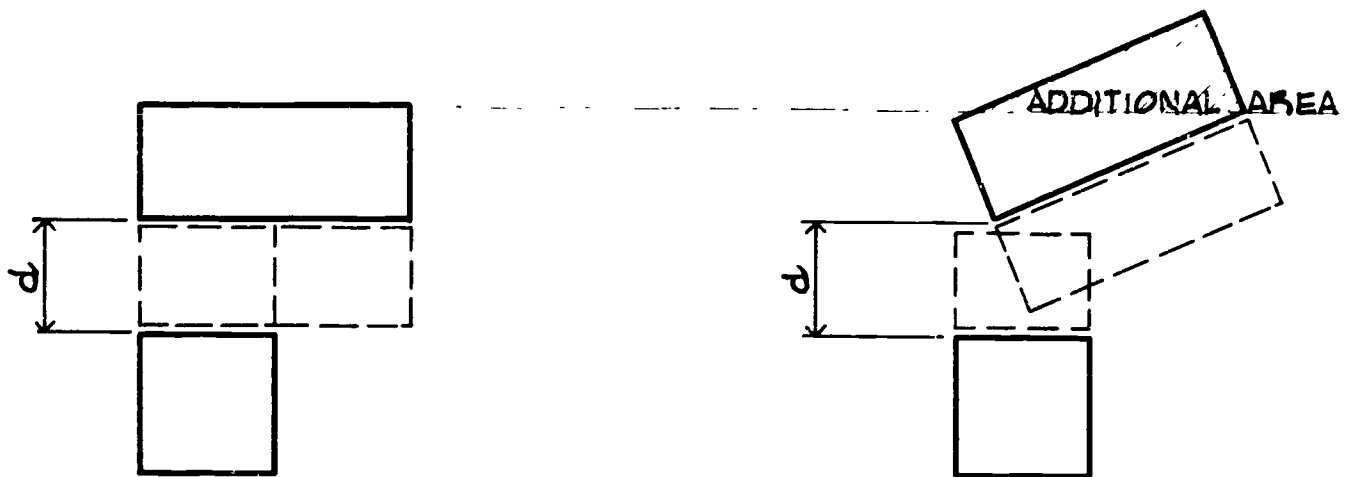

- b. Given an optimum area (110 sq. ft. for a single room), an odd shaped room will hold all of the required items of furniture in an efficient manner. However, the degree of furniture adaptability will increase sharply.

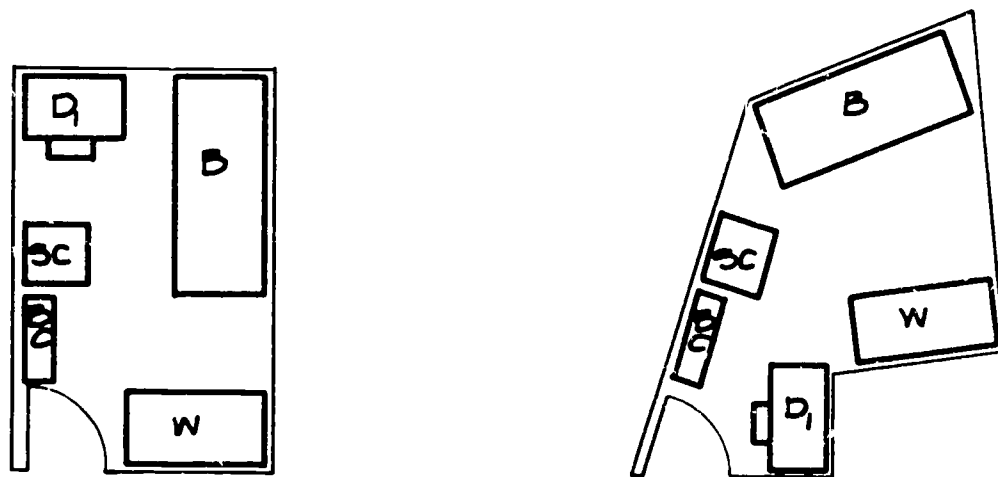

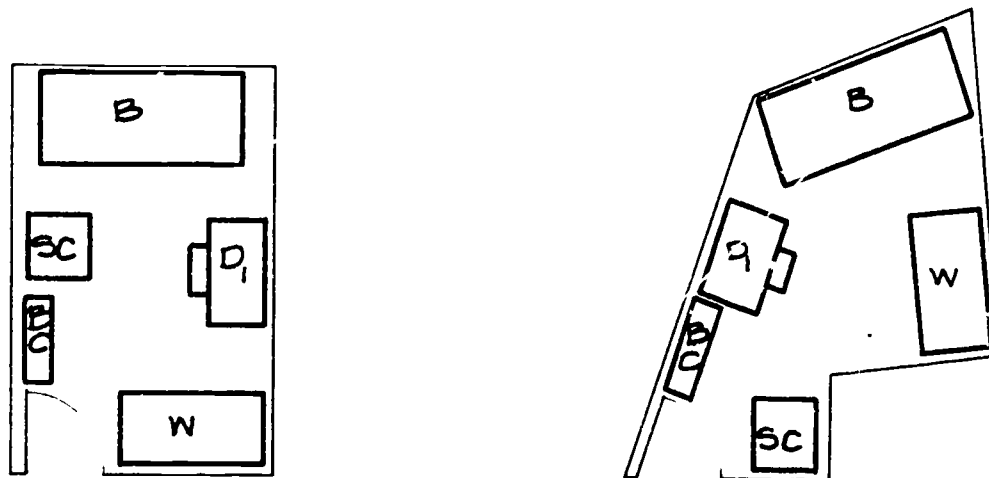

c. Oblique corners may result in an efficiency of use space.

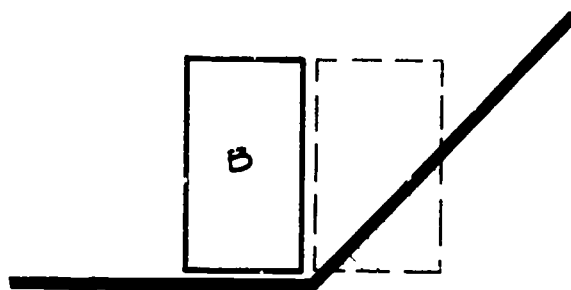

d. Acute corners may result in an efficiency of use space.

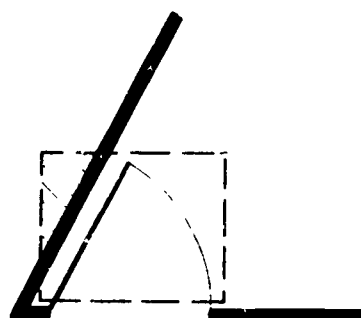

## APPENDIX VII

### ADAPTABILITY STUDIES—STRUCTURAL SPANS

The forty-foot span with a twenty-foot bay length derived from study of many existing dormitory plans as well as proposed ideal environment spaces. All of the existing University of California dormitory plans were considered. On the national scale, older dormitory types were studied along with the newer ones being built. Whereas ten years ago most structures were a simple, rectangular shell, a present day trend seems to involve more complex configurations relating to more complex hierarchies in the social structure.

As a frame of reference, residence halls were classified in five basic plan types:

- A. The Double Loaded Corridor—a series of perimeter rooms on both sides of a five-foot + corridor, usually with gang baths and stairs at either end (Plate 32).
- B. The Gallery Plan—a variation of the Double Loaded Corridor with rooms on one side only of an open or closed corridor (Plate 32).
- C. The Extended Core Plan—a series of perimeter rooms around four sides of a structure. In the center is a core of service rooms including gang toilets, janitor's closets, elevators, etc. A corridor usually surrounds the core on four sides (Plate 32).
- D. Vertical House—a series of 4, 6, 8 rooms, suites, etc. A stair serving one or two such configurations of rooms or suites is provided, creating the feeling of an individual house (Plate 33).
- E. Point Tower Plan—usually but not always high-rise with vertical circulation such as stairs and elevators in a center core along with gang baths and service rooms. The rooms, suites, and arrangements are on the perimeter. Shared baths are often used with suites of 4, 6, 8 persons (Plate 33).

Once these five types were defined, all plans were classified accordingly, and a study of their structural requirements begun. These plans were studied not as actually constructed, but rather as they would need to be framed to permit maximum adaptability.

Based on these studies, frequency of occurrence charts showed that very few long spans over 35 feet were used and that a corresponding maximum short span of 20 feet was adequate. Coupling this study with spatial needs and assuming a fixed toilet space, it was concluded that a maximum 35-foot x 20-foot bay would be required. Provision by a given system of bays larger than 35 feet x 20 feet will, of course, be acceptable provided the required spans are taken care of.

A variety of bay sizes will be needed in addition to accommodate balconies, overhangs, stairways, and elevators. The precise conditions for these accommodations will be defined in the performance specifications for structure.

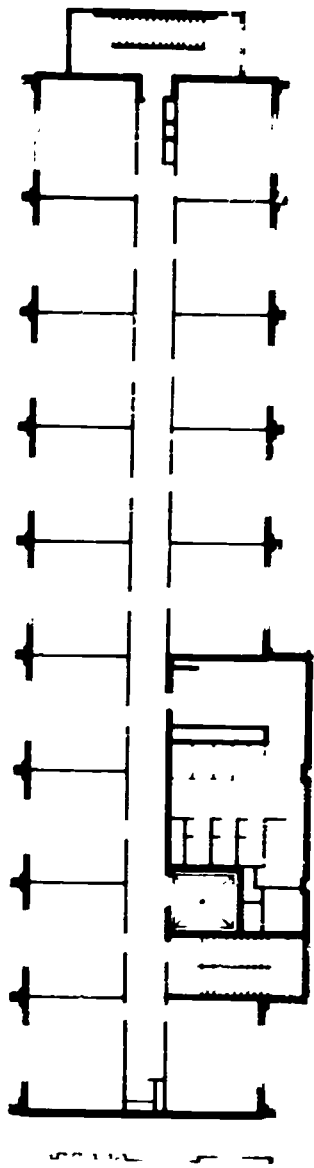

**1** DOUBLE LOADED CORRIDOR

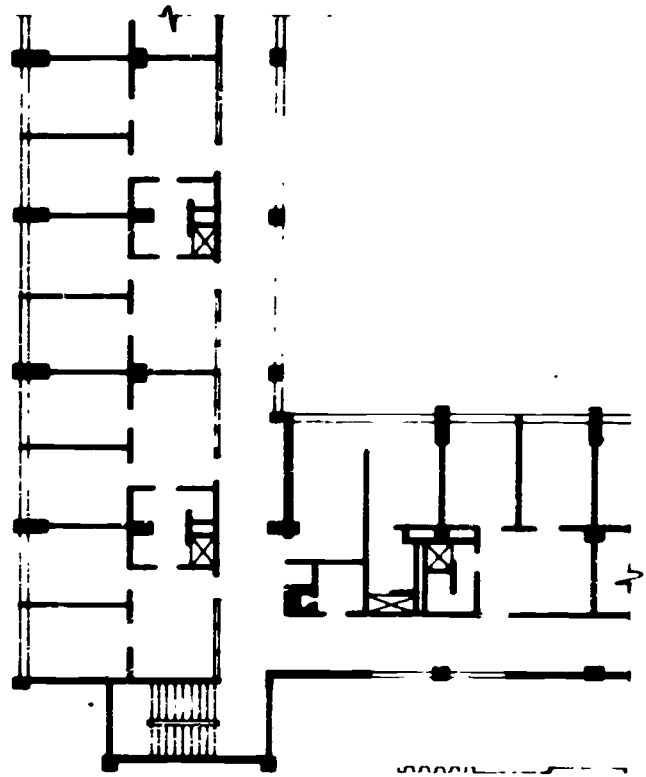

**2** GALLERY TYPE

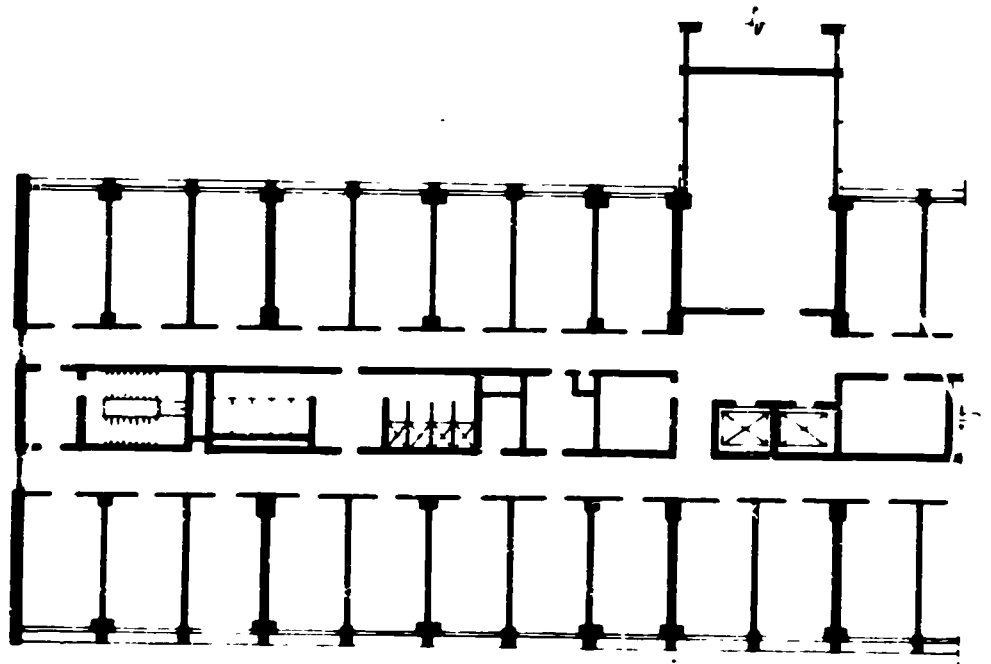

**3** EXTENDED CORE PLAN

3

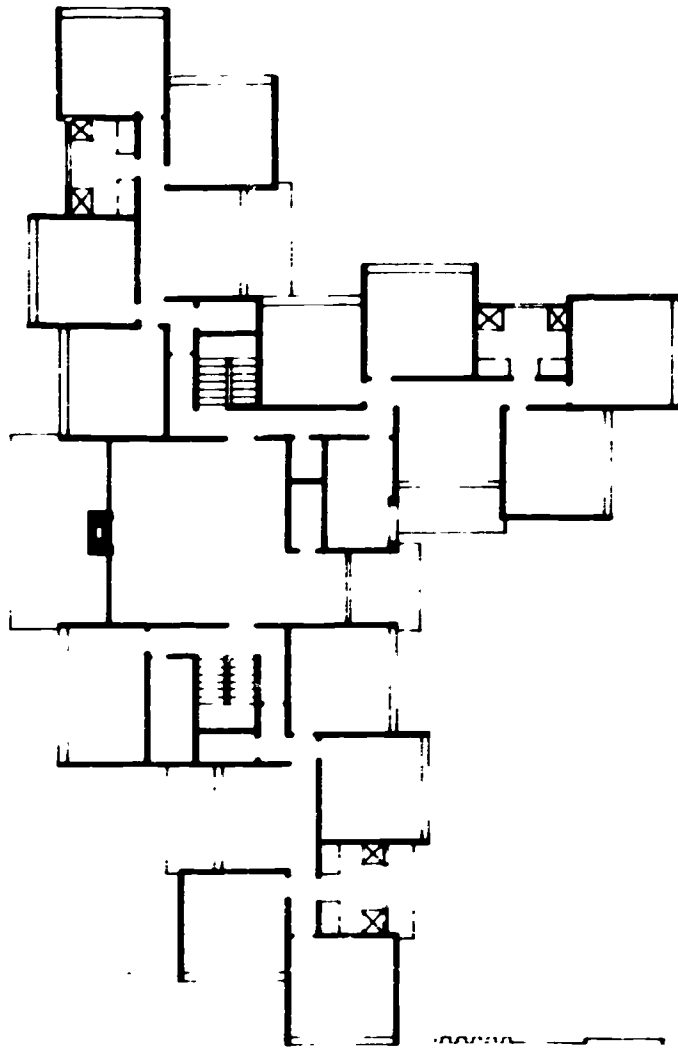

**4** VERTICAL HOUSE

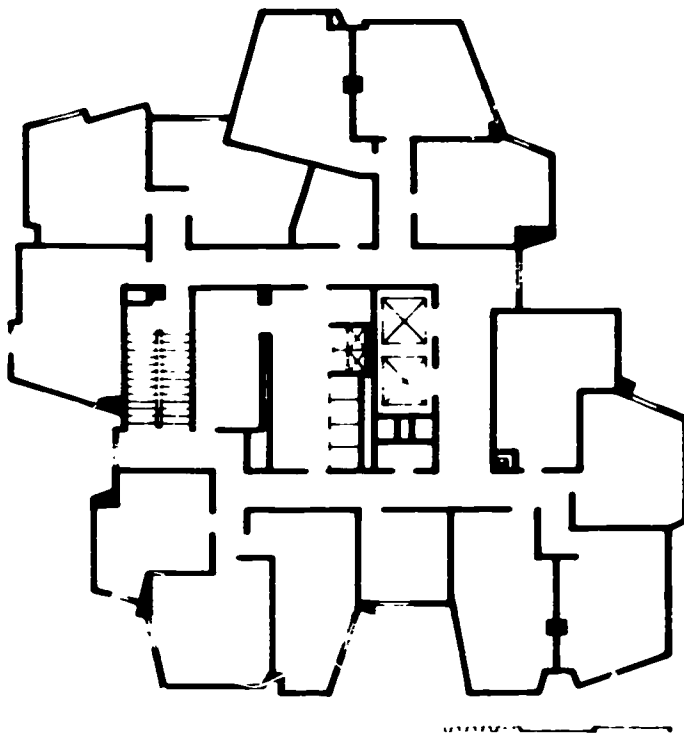

**5** CORE PLAN

BASIC ROOM HALL PLAN TYPES

[plate 33]

119 and 120



## **CREDITS**

### **PLATE**

1. **Building Systems Development, Inc.**
2. **University of Michigan, Ann Arbor, Michigan  
Swanson & Associates—Architects**
3. **University of Delaware, Newark, Delaware  
Howell Lewis Shay & Associates—Architects**
4. **Trailer Plan, University of California, Santa Cruz**
5. **Building Systems Development, Inc.**
6. **Building Systems Development, Inc.**
7. **Revelle College, University of California, San Diego  
Robert Alexander—Architect**
8. a) **Indiana University, Bloomington, Indiana  
E. D. James—Architect**  
  
b) **Van Hoosen Hall, Michigan State University, East Lansing, Michigan**
9. **Indiana University, Bloomington, Indiana  
E. D. James—Architect**
10. a) **Stiles College, Yale University  
Eero Saarinen & Associates—Architects**  
  
b) **St. Olaf College, Northfield, Minnesota  
Sovik, Mathre and Madison—Architects**
11. a) **University of California, Berkeley  
Warnecke & Warnecke—Architects**  
  
b) **University of California, Los Angeles  
Welton Becket & Associates—Architects**
12. **Durward Hall, Colorado State University, Fort Collins, Colorado  
Bunts & Kelsey—Architects**
13. **University of California, Berkeley  
Warnecke & Warnecke—Architects**
14. **McMahon Hall, University of Washington, Seattle  
Kirk, Wallace & McKinley—Architects**

15. University of California, Los Angeles  
Welton Becket & Associates—Architects
16. Building Systems Development, Inc.
17. a) Residence Hall Unit 1, University of California, Irvine  
William Pereira & Associates  
Frederick E. Emmons & Associates  
Blurock, Ellerbroek & Associates
- b) Washington University, St. Louis, Missouri  
Hellmuth, Obata & Kassabaum—Architects
- c) Hedrick Hall, University of California, Los Angeles  
Welton Becket & Associates—Architects
18. Williams Village, University of Colorado, Boulder  
Hobart D. Wagener—Architect
19. Williams Village, University of Colorado, Boulder  
Hobart D. Wagener—Architect
20. University of California, Berkeley  
Warnecke & Warnecke—Architects
21. Ryerson Hall, University of California, Davis  
Kitchen & Hunt; John Funk—Architects
22. Regan Hall, University of California, Davis  
Kitchen & Hunt; John Funk—Architects
23. Hedrick Hall, University of California, Los Angeles  
Welton Becket & Associates—Architects
24. Residence Hall 4, University of California, Riverside  
George Vernon Russell—Architect
25. Anacapa Hall, University of California, Santa Barbara  
Pereira & Luckman—Architects
26. Residence Hall, Unit 1, University of California, Irvine  
William Pereira & Associates  
A. Quincy Jones, Frederick E. Emmons & Associates  
Blurock, Ellerbroek & Associates—Architects
27. Revelle College, University of California, San Diego  
Robert Alexander—Architect
28. Revelle College, University of California, San Diego  
Robert Alexander—Architect

29. Residential College 1, University of California, Santa Cruz  
Wurster, Bernardi & Emmons—Architects
30. Residential College 2, University of California, Santa Cruz  
Joseph Esherick & Associates—Architects
31. Stern Hall, University of California, Berkeley  
Corbett and MacMurray; W. W. Wurster—Architects
32.
  - 1) Ehrman Hall, University of California, Berkeley
  - 2) Christian Brothers College, Memphis, Tennessee  
A. L. Aydelott & Associates—Architects
  - 3) Hedrick Hall, University of California, Los Angeles
33.
  - 4) Residence Hall, Unit 1, University of California, Irvine
  - 5) St. Olaf College, Northfield, Minnesota  
Sovik, Mathre, & Madson—Architects

## BIBLIOGRAPHY

- An Academic Plan for the University of California.* Approved in principle by The Regents of the University of California, July, 1961.
- American Standards Association. American Standard Specifications for Making Buildings Accessible to, and Usable by, the Physically Handicapped.*
- Boyer, Ronald K. *The Student Peer Groups: Its Effect on College Performance.* Ph.D. dissertation, Case Institute of Technology, 1965.
- California State Colleges. *Development Guide for Campus Housing.* July, 1968.
- Clark, Burton., and Martin Trow. *Determinants of College Student Sub-Cultures.* 1963.
- The Committee for New Colleges. *Student Reactions to Study Facilities with Implications for Architects and College Administrators.* A Report to the Presidents of Amherst College, Mount Holyoke College, Smith College, and the University of Massachusetts. Amherst, Massachusetts, 1960.
- Dober, Richard. *The New Campus in Britain: Ideas of Consequence for the United States.* New York: Educational Facilities Laboratories, Inc., publication.
- Educational Facilities Laboratories, Inc. *SCSD—The Project and the Schools.* New York: Educational Facilities Laboratories, Inc., May, 1967.
- Freedman, Marvin B. "The Passage Through College," *Journal of Social Issues*, 1965.
- Geddes, Brecher, Qualls and Cunningham, Architectural Consultants. *Study of Undergraduate Men's Housing Systems*, University of Pennsylvania.
- Higgs, Eugene E., M. Louise Stewart, and Linda Wright. "Residence Hall Planning Aids," *College and University Physical Facility Series.* U. S. Office of Education, Department of Health, Education and Welfare Publication, No. 51004-9A, January 1965.
- Massachusetts Institute of Technology Planning Office. *A Program for Undergraduate Men's Housing.* Cambridge, Mass.; MIT Press, August 1965.
- McHenry, Dean E. "Small College Program for a Large University," *College and University Business*, Vol. 37, No. 1, July, 1964.
- Newcomb, T. M. *Personality and Social Change.* New York: Dryden Press, 1943.
- Proceedings of the University of California Sixteenth All-University Faculty Conference*, March 27, 28, and 29, 1961.
- Real Estate Research Corporation. *Analysis Student Housing Market and Alternate*

*University Housing Programs, 1963-1975.* Prepared: Board of Regents, University of California, Berkeley, California, January 1965.

Riker, Harold C., and Frank G. Lopez. *College Students Live Here: A Study of College Housing.* New York: Educational Facilities Laboratories, Inc., Publication, 1961.

Sanford, Nevitt (ed.). *The American College.* New York: John Wiley and Sons, 1962.

Trow Martin. *Reflections on the Residence Hall Program.*

University of California. *Comprehensive Housing Report* (revised April 14, 1965).

. *Contract Documents and Performance Specifications.* University Residential Building System, Publication No. 1, June 1967.

. *Report of the Ad Hoc Committee on Residence Hall Operations,* April 30, 1964.

. Standing Committee on Residence Halls, meeting of August 29 and 30, 1966, Hilton Inn, San Francisco International Airport.

. *Storage Study.* University Residential Building System, Publication No. 4, October 1967.

Walker, Evan H., Student Housing Consultant. *Student Housing Study,* University of Guelph, November 1965.

Wolk, Ronald A. *Alternative Methods of Federal Funding for Higher Education.* Berkeley, California, Carnegie Commission on Higher Education, 1968.

Wristan, Henry. *Academic Procession.* New York, 1959.