

DOCUMENT RESUME

ED 035 191

EF 002 609

AUTHOR Vu, C. C.; Vickery, D. J.  
TITLE The Design of Physics Laboratories for Asian Second Level Schools.  
INSTITUTION Asian Regional Inst. for School Building Research, Colombo (Ceylon).  
SPONS AGENCY United Nations Educational, Scientific, and Cultural Organization, Paris (France).  
REPORT NO ARISBR-Study-4  
PUB DATE 68  
NOTE 96p.  
AVAILABLE FROM The Documentalist, Asian Regional Institute for School Building Research, P. O. Box 1368, Colombo, Ceylon

EDRS PRICE MF-\$0.50 HC Not Available from EDRS.  
DESCRIPTORS Building Plans, Classroom Environment, Classroom Furniture, Educational Economics, Educational Environment, \*Facility Utilization Research, Flexible Facilities, \*Laboratories, Laboratory Equipment, Laboratory Procedures, \*Physics, Physics Experiments, School Design, School Planning, Science Equipment, \*Secondary Schools, \*Teaching Methods

ABSTRACT

The functions, equipment, furnishings, and design spaces for physics teaching in lower and higher secondary schools are described. The following requirements for physics laboratories are discussed--(1) movable furniture, (2) group facilities, (3) visual display areas, and (4) benches and work surfaces. Floor plans, photographs, and diagrams are included. (TG)

002 609

ED035191

# STUDY 4

## THE DESIGN OF PHYSICS LABORATORIES FOR ASIAN SECOND LEVEL SCHOOLS

U.S. DEPARTMENT OF HEALTH, EDUCATION & WELFARE  
OFFICE OF EDUCATION

THIS DOCUMENT HAS BEEN REPRODUCED EXACTLY AS RECEIVED FROM THE  
PERSON OR ORGANIZATION ORIGINATING IT. POINTS OF VIEW OR OPINIONS  
STATED DO NOT NECESSARILY REPRESENT OFFICIAL OFFICE OF EDUCATION  
POSITION OR POLICY.



ASIAN REGIONAL INSTITUTE FOR  
SCHOOL BUILDING RESEARCH

Sponsored by Unesco

COLOMBO

1968

002 609

ED035191

ASIAN REGIONAL INSTITUTE FOR SCHOOL BUILDING RESEARCH,

STUDY no. 4

THE DESIGN OF PHYSICS LABORATORIES  
FOR ASIAN SECOND LEVEL SCHOOLS.

by

C. C. YU  
*Educational Consultant in Physics, ARISBR*

&

D. J. VICKERY  
*Architect and Unesco Head of Project, ARISBR*

COLOMBO  
1968

Prepared and Published by The Asian Regional Institute for School Building Research, P.O.Box 1368, COLOMBO, Ceylon. 2000 copies

Publications of the Institute:

\* Occasional papers; school building

- no. 1 Climate and school building design in Java. (Out of print)
- no. 2 The shading of school buildings in South-East Asia; sun-shading diagrams. (Out of print)
- no. 3 Comparative anthropometric data: A - for use in Indian schools.
- no. 4 Comparative anthropometric data: B - for use in Thai schools.
- no. 5 Comparative anthropometric data: C - for use in Indonesian schools.
- no. 6 Comparative anthropometric data: D - application of data
- no. 7 A comparative study of multi-purpose rooms in educational buildings.
- no. 8 Comparative anthropometric data: E - for use in Philippine schools.
- no. 9 Environmental control in school buildings through planting.
- no. 10 Primary school buildings in Asia; administration, facilities, programmes.
- no. 11 School building development group work.
- no. 12 A primary school design workbook for humid Asia.
- no. 13 A method of reducing classroom requirements in primary schools in Asia.

\* nos. 1 & 2 have separate French editions; nos. 7 and 9 are available in Indonesia from:

The Director  
Pusat Penelitian Gedung2 Sekolah,  
Djl. Tamansari 124  
BANDUNG, Indonesia.

Studies

- no. 1 The design of home economics laboratories for Asian second level schools
- \*\* no. 2 The design of biology laboratories for Asian second level schools
- \*\* no. 3 The design of chemistry laboratories for Asian second level schools
- no. 4 The design of physics laboratories for Asian second level schools

\*\* In preparation, for later 1968 publication.

Buildings for Education, v.1: nos. 1, 2, 3, 4.  
v.2: nos. 1, 2 (in preparation)

Annual report, 1967

Information bulletin, 1967

These publications may be obtained from:

The Documentalist  
Asian Regional Institute for School  
Building Research,  
P.O.Box 1368, COLOMBO, Ceylon.

## P R E F A C E

Great changes are currently taking place in the teaching of science to secondary school children. The emphasis is moving from teacher-centric activity involving student verification of principles explained in lectures, to pupil-centric work in which, through guided experiments, the children endeavour to find out for themselves and in their own way the principles or laws relating to the particular topic they are studying. Demonstration *follows*, rather than *precedes*, experimental work and *ad hoc* group discussion replaces formal lecturing. Every science lesson now needs to be held in the laboratory, for in one period the activity may change from student experiment, to discussion, to teacher demonstration, back to experiment and finally, recapitulation, perhaps by film-strip or brief talk.

These changes will inevitably be reflected in the nature of the building accommodation and furniture that is provided for the new science teaching. It is important, for example, that new laboratories be designed not only to house laboratory benches but also to provide space for discussions; initiatives that are encouraged in the student by the new teaching methods demand movable rather than fixed furniture; facilities are required for group project work and the need for display and visual aid areas is much greater than was the case in the past.

This publication endeavours to provide information on the functions, furnishing and design of spaces for physics teaching in lower and higher secondary schools. It has been framed in a regional context with physics syllabuses of the Asian Region in mind but variations to the suggestions made will sometimes be necessary depending on local conditions. For example, the furniture shown is intended for construction in timber because it is the most readily obtainable and cheapest material available in most countries of the Region. Some States in which steel is cheap, may prefer to use light sections. Apart from considerations such as these, the general principles outlined by the Consultant Educationist who has participated in the preparation of this document will be found valid in all countries.

The study has been approached in four stages. In the first stage the situation as it affects physics teaching in the Region was studied together with sizes of teaching groups and age ranges of second level children in the countries of the Region. The changes in teaching method that are taking place in the Asian Region in the field of Physics were identified. Standards of accommodation, where they exist, were examined.

The first stage was followed by a systematic study of activities in the physics laboratory made by the Architect in collaboration with the Consultant, a specialist in this field, who outlined the various teaching requirements, the material to be

taught and the changes in teaching method currently taking place. From this study, furniture was developed and a prototype of a movable student bench produced in the institute's workshop. Finally, the space required in the laboratory was quantified.

The drawings of laboratory layouts shown at the end of this paper were originally produced as models before reduction to the two dimensional form.

The background to the production of this paper is the urgent need for a ready reference to the design of physics laboratories in the Asian region. In some countries where architectural services are not available the situation is difficult, for not only is it impossible for those responsible for design to translate educational requirements into useful and economical building accommodation, but also frequently they do not realise the need for the dialogue between the educator and the designer that is an essential prerequisite to good school building.

Even where an architect's services are available, then there is often insufficient time for the protracted discussions with physics specialists that are so vital to laboratory design. This paper may assist in providing some useful background material in this context.

C O N T E N T S

	<u>Page</u>
<i>Preface</i>	1
<i>Contents</i>	3
<i>List of Figures</i>	4
<i>List of Tables</i>	5
<i>List of Plates</i>	5
<i>Summaries in English and French</i>	5 & 6
<b>CHAPTER 1 - <u>MOTIVES IN THE DESIGN OF PHYSICS LABORATORIES</u></b>	<b>7</b>
1.01 <i>Introduction</i>	7
1.02 <i>The main purpose of teaching Physics</i>	8
1.03 <i>The teaching methods used in Physics</i>	9
1.04 <i>Motives in design</i>	12
<b>CHAPTER 2 - <u>THE ENVIRONMENT IN THE LABORATORY</u></b>	<b>13</b>
2.01 <i>General</i>	13
2.02 <i>Children's body sizes</i>	13
2.03 <i>Standing and sitting</i>	14
2.04 <i>Seats</i>	15
2.05 <i>Storage</i>	16
2.06 <i>Spaces "in between"</i>	17
2.07 <i>Illumination in Physics and General Science laboratories</i>	18
2.08 <i>Thermal comfort in Physics laboratories</i>	21
<b>CHAPTER 3 - <u>FURNITURE IN THE PHYSICS LABORATORY</u></b>	<b>24</b>
3.01 <i>General</i>	24
3.02 <i>Facilities required in the Physics laboratory</i>	24
3.03 <i>The laboratory</i>	25
3.04 <i>The student work-table</i>	27
3.05 <i>Wall-fixed work-tables</i>	31
3.06 <i>Fixed work-table storage units</i>	32
3.07 <i>Store access unit</i>	32
3.08 <i>Project work-table</i>	33
3.09 <i>Utility table</i>	34
3.10 <i>Ancillary furniture</i>	34
3.11 <i>Teacher's demonstration bench</i>	37
<b>CHAPTER 4 - <u>THE DESIGN OF PHYSICS LABORATORIES</u></b>	<b>39</b>
4.01 <i>The design problem</i>	39
4.02 <i>The solution</i>	40
<b>CHAPTER 5 - <u>THE PHYSICS LABORATORY STORE</u></b>	<b>69</b>
5.01 <i>General</i>	69
5.02 <i>The nature of the items to be stored</i>	69
5.03 <i>Furniture in the store</i>	70
<b>APPENDICES</b>	<b>73</b>
<b>BIBLIOGRAPHY</b>	<b>89</b>
<b>INDEX</b>	<b>97</b>

LIST OF FIGURES

Page

1. Location of working surface	15
2. Standing and sitting at the working surface	16
3. Zone of convenience for storage	17
4. Spaces between benches	18
5. Illumination by daylight in laboratories in differing cross-section	20
6. Orientation of the laboratory	22
7. Arrangement of furniture for good cross ventilation	23
8. Grouping of students in the Physics laboratory	27
9. A typical Physics experiment occupying the full bench length	28
10. The working surface for a movable student's bench	29
11. Pull-out writing surfaces	29
12. Cramping to the working surface	30
13. Accumulator storage shelf	30
14. Continuous work-table fixed to wall	31
15. Storage at the wall-fixed work-table	32
16. Store access hatch	33
17. Project work-table	33
18. Students' book and bag storage unit	34
19. Book and periodical shelving	35
20. Chart cabinet	36
21. Teacher's demonstration bench	37
22. 40-place laboratory for hot, humid areas	45
23. Arrangements of movable furniture in the 40-place laboratory	47
24. View of 40-place laboratory for hot, humid areas	49
25. 40-place laboratory on one side of a double-banked corridor	51
26. Arrangements of movable furniture in the 40-place laboratory	53
27. View of 40-place laboratory on one side of a double-banked corridor	55
28. 20-place laboratory on one side of a double-banked corridor	57
29. Arrangements of movable furniture in a 20-place laboratory	59
30. View of 20-place laboratory on one side of a double-banked corridor	61
31. 20-place laboratory for hot, humid areas	63
32. Arrangements of movable furniture in a 20-place laboratory	65
33. View of a 20-place laboratory for hot, humid areas	67



**LIST OF TABLES**

	<u>Page</u>
<i>I Mean standing heights of Asian secondary school children</i>	13
<i>II Minimum-requirement illumination level in different countries</i>	19
<i>III Facilities required in the Physics laboratory</i>	23

**LIST OF PLATES**

	<u>Facing Page</u>
<i>1. View of prototype physics table for 4 places</i>	31
<i>2. Prototype movable physics table for 4 places</i>	31

- - - - -

**S U M M A R Y**

There is a change in emphasis in the new physics teaching methods in the Asian Region from teacher-centric to pupil-centric teaching. Future laboratories will need to be designed to provide facilities for student experiments, discussion, demonstrations, students' project work and greater use of visual aid materials. This involves bringing the classroom into the laboratory and abandoning the separate physics lecture rooms; it requires easily movable student work benches at which the children, through guided experiments can find out for themselves and in their own way, the principles relating to the particular topics they are studying.

These principles have led to the design of essential furniture to facilitate the practice of modern teaching methods in an environment which ensures reasonable illumination and thermal comfort for the children. Emphasis is given to the correct sizing of furniture in relation to body sizes of Asian secondary school children.

Designs suitable for use in either hot-humid or hot-dry (or cold) climates are given for laboratories for teaching groups of 20 and 40 children.

It is concluded that the per place requirements for larger laboratories are between 3.4 and 3.8m<sup>2</sup> and for smaller laboratories of 20 places, 4.5m<sup>2</sup>. These areas include storage space, project space and dark room. This is a more economical use of space than is presently the case in some Asian countries in which the laboratory is used together with a lecture room, the combined areas of which may exceed 5m<sup>2</sup> per place.

## S O M M A I R E

Dans les régions d'Asie un changement d'accent s'est effectué à propos de nouvelles méthodes adoptées pour l'enseignement de la physique. L'accent qui était sur l'enseignement à la méthode "teacher-centric" (c'est-à-dire l'instituteur est le centre de la classe) est maintenant sur l'enseignement "pupil-centric" (c'est-à-dire les élèves sont le centre de la classe). A l'avenir, il sera nécessaire de dessiner les laboratoires de manière que les élèves puissent faire des expériences, avoir des discussions et des démonstrations. En même temps les laboratoires doivent être pourvus de facilités pour le travail de projet des élèves et de facilités pour l'usage d'aide visual. Ceci entraînera moyennant l'abandonnement des salles d'études séparées. En fait, il faudra "apporter" la salle d'études au laboratoire ce qui exige de tables d'expérimentation portatives où les élèves puissent faire des expériences et découvrir individuellement les principes en rapport au sujet qu'ils sont en train d'étudier.

Pour cette raison il faut dessiner les meubles qui facilitent l'application de méthodes d'enseignement nouvelles dans un environ d'illumination suffisante qui garantit un confort thermique aux enfants. L'accent est mis sur une construction bien ajustée à la taille des élèves d'écoles secondaires d'Asie.

Ci-joint vous trouverez des dessins de laboratoires pour l'enseignement de 20 et 40 élèves. Ils sont adaptés à la construction dans les deux climats, soit chaud-humide, soit chaud-sec (ou froid).

En conclusion il faut rappeler que la place nécessaire par élève est de  $3.4m^2$  à  $3.8m^2$  s'il s'agit de grandes laboratoires. Une surface de  $4.5m^2$  est nécessaire si le laboratoire est construit pour accommoder 20 élèves. Ceci comprend la place de rangement, la chambre noire et la place de projets. Ce genre d'utilisation de l'espace à disposition est plus économique que celui en usage à présent dans quelques pays d'Asie où le laboratoire et la salle d'études sont construits séparément. Dans ce cas la surface combinée du laboratoire et de la salle d'études peut surpasser  $5m^2$  par élève.

## CHAPTER 1

### MOTIVES IN PHYSICS LABORATORY DESIGN

#### 1.01 Introduction

This paper is the result of a study made in order to be able to suggest a suitable environment for the teaching of physics in secondary schools in the Asian Region. There are, of course, considerable difficulties inherent in attempting this: concepts of a suitable laboratory will change with time; differing points of view may lead to differing concepts of what is or is not suitable, it is in any case almost impossible to provide one solution to such a many faceted problem.

Whatever the solutions that are finally developed, it is first necessary to define the design problem and identify the needs to which the design solutions must respond. Basically the laboratory will have to provide good conditions for both teaching and learning. Good teaching encourages a ready understanding not only of the concepts of a subject but also of its objectives. It may involve many different teaching methods and techniques. In this context it will be related to the general objectives of science education which will be decided by the philosophy of general education in each individual country.

Before designing a physics laboratory it is necessary briefly to define the aims of physics teaching and the teaching methods to be used.

#### 1.02 The Main Purpose of Teaching Physics

The study of the natural sciences is common in all countries of the region and the reasons for which it is taught vary little from country to country. In general these are:-

- a) To develop a responsive attitude towards science;
- b) By means of scientific and technological developments, to improve general living conditions.

Physics teaching is a part of science education. Within the framework of general science education, its specific objectives may be said to be -

- 1) to provide students with an opportunity to use the methods of science and to cultivate a scientific attitude - that is to enable them to approach physics and to use its principles in the context of their own environment;

- ii) to give an understanding of the main branches of physics without necessarily attempting a comprehensive survey of the subject and develop an understanding of physical principles and their place in normal every day life;
- iii) to develop in the student certain practical skills and accomplishments such as observation, reflective thinking and problem solving which will be useful in further science studies and in every day life. These accomplishments will be acquired in the process of laboratory work in which the ability of the students to do things for themselves will be stressed;
- iv) to provide inspiration to the potentially brilliant student who may find a future vocation in the field of physics.

### 1.03 The Teaching Methods used in Physics

The design of a teaching space should reflect the methods of teaching that are to be used in it. For example a university lecture hall is used for lecturer-centric work. The audience is static and the sort of space that will emerge will probably be fan-shaped on plan with the students arranged concentrically in front of a lecture table which will form the focus of attention.

In a primary school classroom where the activities are child-rather than teacher-centric, the children will work in small groups. A space that is square on plan and with walls on which the children can draw and hang drawings would be most suitable.

The physical difference between the university lecture hall and the primary school classroom are due to the different methods of teaching for which they are provided.

It is important therefore, before attempting to design a physics laboratory to examine carefully the methods currently in use in teaching physics. They are:-

#### a) Laboratory Work

The laboratory is the core of all physics teaching and therefore, it is essential that it be tailored precisely to the methods used. The first and most important teaching method is experimental work. In this the students are encouraged to develop a sense of enquiry, to use scientific methods effectively and to develop certain manual skills in connection with their apparatus. The object of experimental work is to develop an understanding of the fact and principles related to physics and to inculcate systematic application of these principles in the minds of the students.

In these approaches to experimental work a number of important points should be considered:-

- i) The work requires to be developed by the teacher and the students together. The process of systematically planning an experiment is perhaps as important to the students as the experiment itself, for the designing of an experiment is an important part of scientific method.
- ii) The investigation by the student should be a true experiment and not merely an exercise. The students should attempt as a result of the study of a problem to find for themselves the solution to it.
- iii) In planning experiments the students, as indeed the teacher, will inevitably have access to laboratory manuals and other textbooks. It is of importance that these texts not be copied in connection with experimental work but rather used as aids.
- iv) The preparation of reports of experiments is important as it gives the student opportunities to organise the data and ideas which he has obtained from the experiment. Where students are too young to prepare a comprehensive written report, then an oral report may be made to the class by an individual or a group. In such a case the report would be followed by a discussion.

b) Lecture/Demonstration Method

The demonstration of certain aspects of physics is an important complement to the laboratory work of the student. It is of added importance when complex apparatus is to be used and difficult processes are involved. In this event the demonstration may precede the student experiment. In general however, in order not to remove the initiative from the student, the lecture/demonstration will follow the experimental attempts of the students and in this way, round-off their experience with a particular topic. Demonstrations are not necessarily the work of the teacher. Students may also participate individually or in groups in giving demonstrations to the rest of the class. The function of a demonstration may be:-

- i) to solve a problem
- ii) to explain a principle or a fact
- iii) to demonstrate a skill or technique
- iv) to evaluate student achievement by committing students to participate in demonstrations
- v) to demonstrate objects or types of apparatus.

The design of the laboratory should be such as to assist in making demonstrations effective. To achieve this the demonstration should be clearly visible. Where more than one set of apparatus is to be demonstrated in a lecture, there must be storage space close to the demonstration table in which to keep apparatus not in use on the table.

Good teaching practice requires that demonstrations be carried out in advance of the lesson and for this it may be useful to provide a preparation area in a small store or other space adjacent to the laboratory.

### c) Project Method

The third function of the laboratory is to provide space for student project work. A student project may involve the study of a problem by an individual or by small groups of students. The study may last from a few days to a period of several weeks. The project approach presents a real opportunity to encourage the students to use scientific method: that is to define the problem, to plan the work, to examine resources, to execute the plan, and finally to draw conclusions. It is in project work that the student may make his most important discoveries.

Lasting as it does for a period ranging from a few days to a few weeks, project work requires a special area in the laboratory in which apparatus can remain standing until it is no longer required. Moreover there should be space in which to display to other students the project results.

The way in which project work is fitted into the normal teaching programme will be conditioned by the following:-

- i) Project work may relate laboratory work and homework in co-curricular activity.
- ii) For the very able students, project work may often form a substitute for normal laboratory work. On the other hand the stimulation provided to less able students by project work makes it valuable to them also.
- iii) Projects provide an excellent opportunity to introduce other agencies into the laboratory. Commercial firms may be willing to lend apparatus or demonstrate their products, visiting lecturers may offer advice and help and, in some countries, private agencies may be persuaded to give prizes and scholarships for outstanding work on individual or group projects.

It is also true to say that the manner of conducting a project will inevitably reflect the breadth of scientific knowledge and interest of the teacher.

The project method is sometimes called the "problem solving" method. It involves the provision of time for the student privately to study and to plan the project. Where groups of students are concerned they can be organized as research teams, the teacher becoming the director of research.

d) Discussion Method

Discussion is one of the most important teaching techniques. Discussion between students and teacher will lead to an understanding of the purpose of experiments, demonstrations and projects. It provides for an exchange of ideas and may initiate different approaches in tackling a particular problem. The purpose of discussion may be:-

- i) to initiate problems;
- ii) to exchange ideas in planning projects;
- iii) to formulate hypotheses from the information collected;
- iv) to draw conclusions;
- v) to clarify and interpret experimental work.

The role of discussion being extremely important in the teaching process and the subject of the discussion being experimental work in one or other of its forms, it is important that it be possible for all discussions to take place in the physics laboratory itself. This requires careful consideration in the planning of a laboratory and in this connection it is important to note the following:-

- i) Discussion needs effective leadership either by the teacher or by a student;
- ii) Discussions may be among a complete class or between small groups of students. The smaller the group the more effective is likely to be the discussion, for every student will then have the chance to offer his own views. However after small group discussion is complete, a full class discussion is needed to unify the conclusions of the several groups.

e) Directed Reading Method

It is extremely important that students studying science should have an opportunity to extend their knowledge beyond the work that can be provided in the laboratory. This extension of experience can be obtained by guided reading and it is important that the physics laboratory in its capacity

as the core of physics work in the school should contain a shelf or two of current general books, reference works and periodicals. Students should have full access to this material and be provided with an opportunity to read it. Periodicals may provide an important source of material for students and help them to select and understand important ideas which they may use in their work.

At the same time the student should be introduced to the school library and permitted to learn from the librarian the use of reference tools and indices and receive advice on how to widen his reading.

f) Other Teaching Methods

For the sake of completeness it may briefly be mentioned that an additional and important aspect of physics studies are field excursions. This work has, of course, no direct effect on laboratory design.

1.04 Motives in Design.

It may be concluded from the foregoing that the design of physics laboratories should be "permissive". There should be sufficient flexibility to allow the use of any teaching method and to permit both the teacher and student to solve problems in ways which are not necessarily those shown in the textbooks but which spring from a desire to improvise and to experiment in the students' own way. This will not result in a rigid laboratory layout but rather in the creation of an environment in which apparatus is conveniently stored, where benches can be pulled here and there as occasion demands, where there is sufficient light easily to see what is being done and where the student is comfortable, be he sitting or standing, listening or active.



CHAPTER 2

THE ENVIRONMENT IN THE LABORATORY

2.01 General

If physics teaching is to be successful then it must take place in an environment which is conducive to learning. Adequate aural, visual and thermal comfort must be provided and furniture must be such that it facilitates the performance of the varied tasks for which it has been designed. In creating this environment the most important factor is the body size of the child. This fixes the sizes and heights above floor level of the working surfaces to which, in turn are related the cill heights of windows and other sources of illumination. The arrangements to provide thermal comfort, particularly in hot, humid areas, will also depend on the standing height of the child. Finally, the question of storage is related to the heights above floor level to which the child can reach both above and below bench level. The heights are related to the body size.

The purpose of this chapter is to draw attention to those factors affecting environment that have a direct bearing on the problems of physics laboratory design outlined in the chapters that follow.

2.02 Children's Body Sizes<sup>1/</sup>

Asian secondary school children range in age from 14 to 18 years and in mean height from 1.46 to 1.57 metres:

TABLE I - Mean Standing Heights - Asian Countries

<u>Age</u> <u>Years</u>	<u>Height</u> <u>Metres</u>
14	1.46
15	1.51
16	1.54
17	1.55
18	1.57

The girls do not differ significantly in height from the boys and there is only a  $\pm 3\%$  difference in mean height among children of secondary school age from Ceylon, India, Indonesia, Pakistan, Philippines and Thailand. North American children are 12% taller than Asian children and it is important not to use the body sizes given in North-American or European books on school buildings when designing the environment for Asian schools.

---

<sup>1/</sup>More detailed reference to this topic is contained in the Institute's Occasional Papers, which are listed in the bibliography at the back of this study.

Of course, all children of a particular age group are not precisely the same height. In a sample of 14 year-olds, whilst the mean height is 1.46m, 66% of the sample will range from 1.39 to 1.53 metres whilst if 95% of the sample is considered the total range will be from 1.30 to 1.63 metres. That means that some children of 14 years - not many - will be taller than the average 18 year-old.

The danger in furniture design is in making chairs and tables *too high* rather than too low, *too big* rather than too small. In this paper, therefore, the standing height used to calculate bench and shelving height, bench depths and widths, is that of the 14 year-old, 1.46m. This assumption will be convenient for the majority of the 15, 16 and 17 year-olds. It will result in rather small furniture for the few very tall students in the 18 year-old group.

### 2.03 Standing and Sitting

For most of the activities in physics laboratories the children should be provided with facilities either to sit or to stand so that, depending on the activity they can learn to conserve as much energy as possible. Indeed it has been shown that reaching, in certain circumstances, requires more energy expenditure when sitting down than standing up.<sup>2/</sup>

However, as the characteristic of work in a science laboratory is a change, depending on activity, from sitting to standing and standing to sitting, most working surfaces need to be arranged at a height convenient for standing work and chairs or stools provided to enable a child also to sit comfortably at this height both for experimental work and for note-writing.

Standing work-or table-top height convenient for a 14 year-old child is 76cm. and this can be regarded as a "datum level" above or below which the heights of all other items of furniture, shelving and fittings as well as cill levels to windows, are fixed.

Just as the "datum" table height was determined by standing, so the depth will be based on the comfortable distance that can be reached forward horizontally, in this case, whilst sitting. This depth is 50cm.

---

2/

McCraeken, E.C. and Richardson, M., *Human Energy Expenditures as Criteria for the Design of Household Storage Facilities*, Journal of Home Economics, v.51, no.3 (March) 1959: p.198-206.

The length of work top that can be conveniently reached and used by a 14 year-old is about 75cm. The resulting space required is shown in Figure.1.

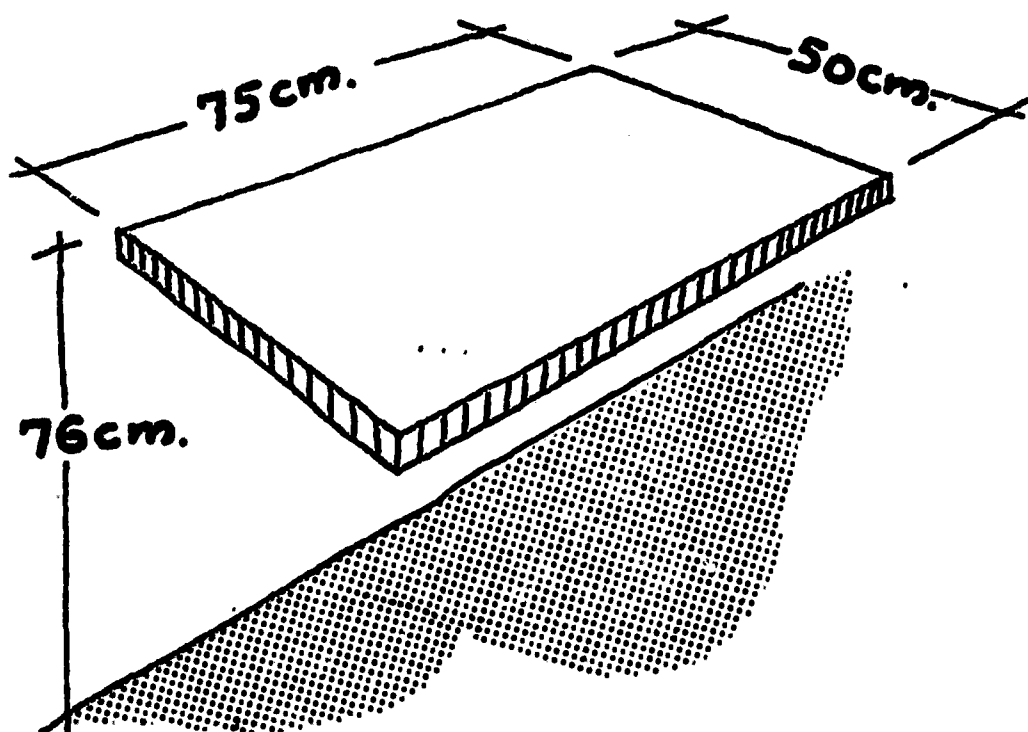

Fig.1 - Location of working surface

#### 2.04 Seats

Having established the size and location in relation to the finished floor level of a work table-top for standing and sitting work, the size and position of seats suitable for use with the work top need to be determined.

The area of a comfortable seat will have to be 28cm. deep and 31cm. wide in order to fit an 18 year-old whilst the height of the seat, if it is to be suitable for a 14 year-old, must be 54cm. with a foot rest at 15cm. from the floor.

The distance from the working surface to the top of the thigh should be no more than 9cm; this means that there is no space for a drawer under the work counter at the place at which the student sits. The projection of the child's knees under the work top will be about 15 cm.

Figure 2. also shows the height of the work top to be convenient for standing work.

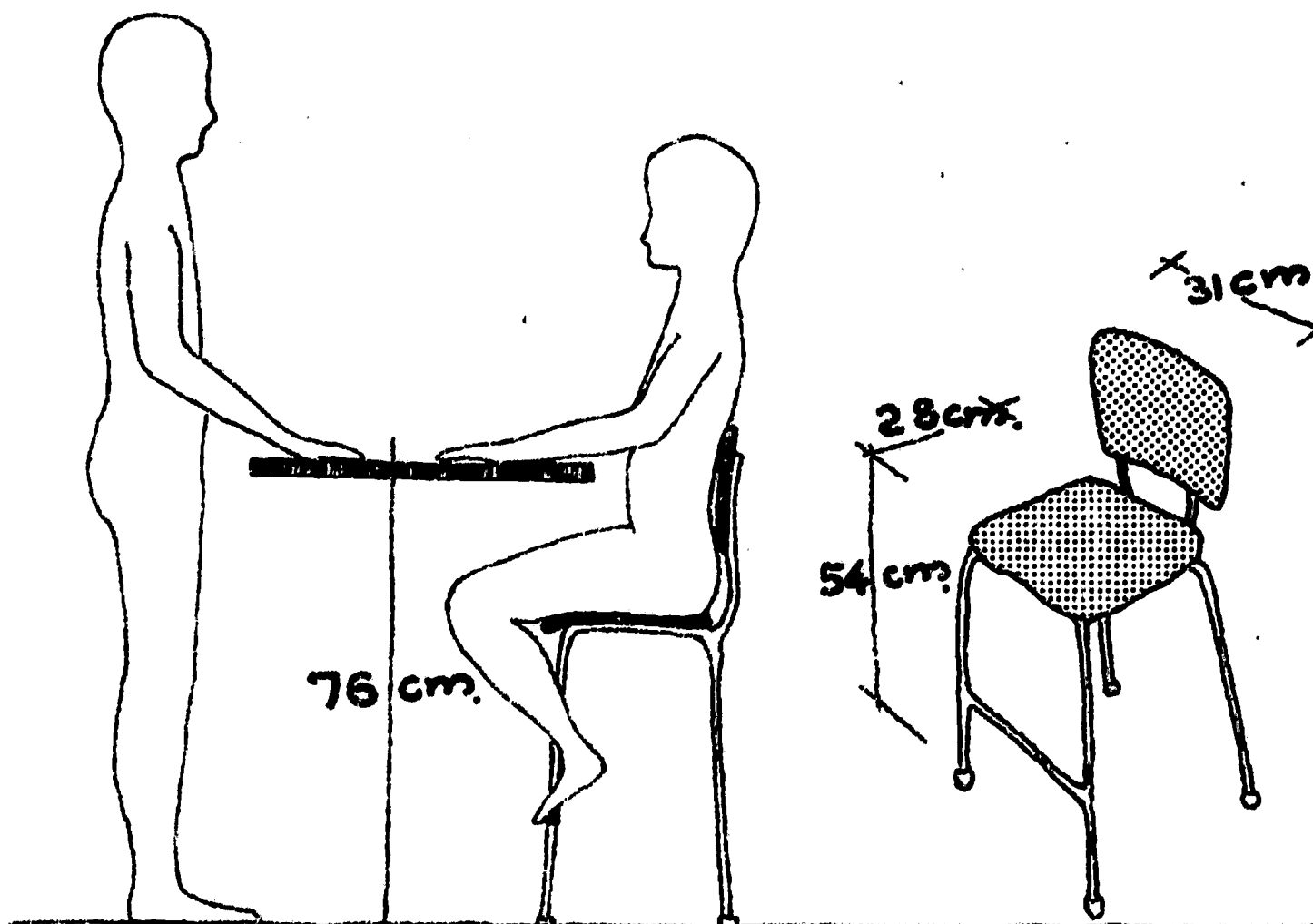

Fig.2 - Standing and sitting at the working surface

### 2.05 Storage

The McCracken-Richardson study<sup>3/</sup> indicates that from an energy conservation viewpoint, there are lower and upper limits for shelving beyond which a very much greater effort is needed to place equipment than is required in what might be called the "zone of convenience". The energy expenditure data in the study suggests that if it is necessary to reach forward over a work top for items heavy or large enough to be lifted with two hands, then these should be stored between 58cm. and 1.09m. above floor level, whilst items that can be lifted with one hand should be stored within a zone between 39cm. and 1.25m. above the floor. Outside this zone should be regarded as dead storage space, and used only for very rarely used pieces of equipment.

<sup>3/</sup> Op. cit. page 14

It will be noted however that storage space down to floor level is used in the case of students' book and bag units (Figure 18). This is because the student only uses this space (and thus only bends down to it) twice - at the start and at the end of every lesson.

The limits for useable storage space are shown in Figure 3 which indicates also the standing work top datum.

It is, of course, possible for a child to reach above 1.25m. The 14 year-old student with a standing height of 1.46m and standing close to the plane of the front edge of the shelving, could reach to 1.76m.

However, it is unwise to arrange shelves above eye-level for the surface is difficult to see and thus difficult to keep clean. Eye-level for a 1.46m. -high child would be at 1.36m above floor level.

The width of shelving above fixed bench tops should be not greater than 25cm. or it will intrude into the useful area of the bench below and may come into contact with the head of a student leaning forward over the bench.

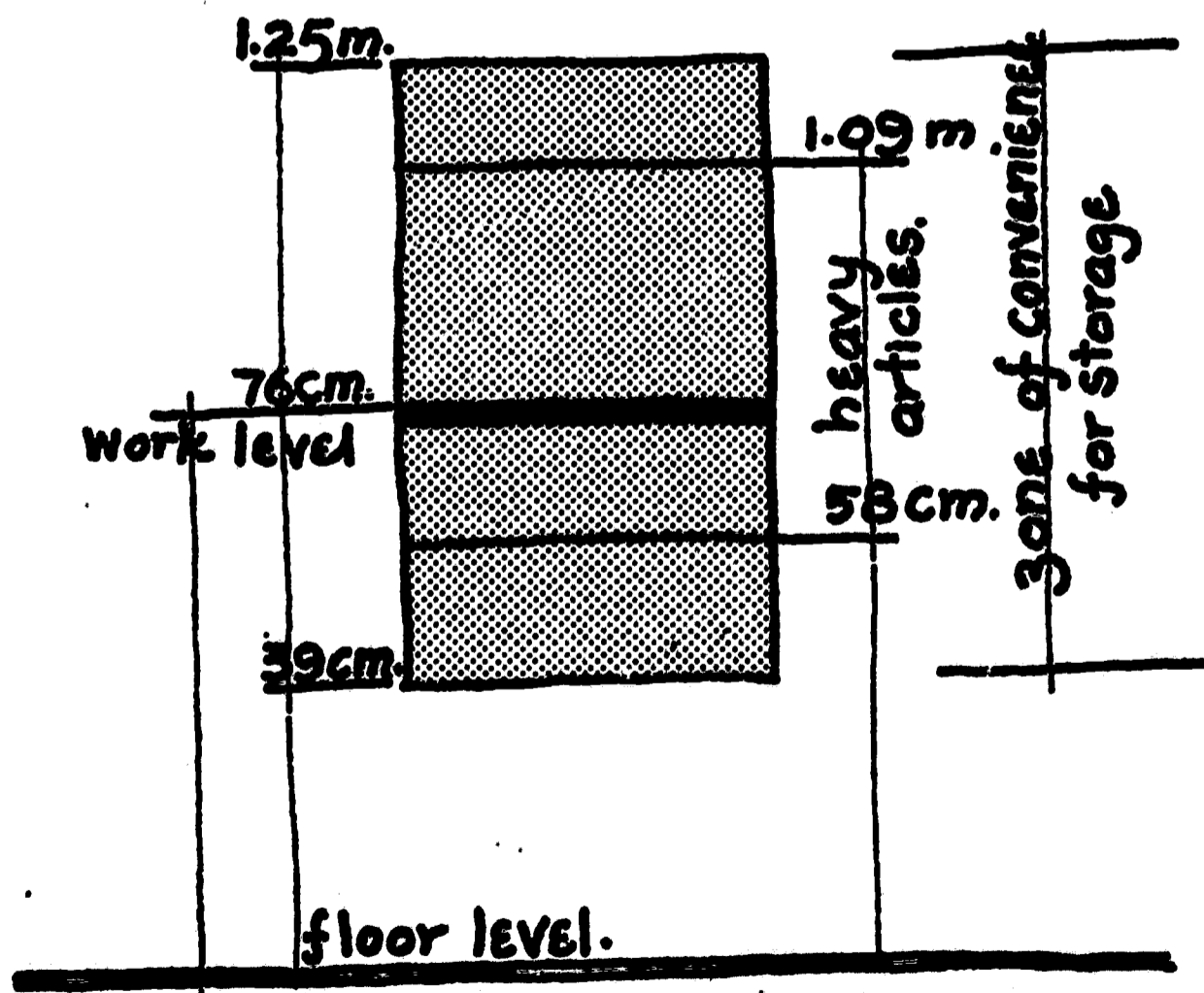

Fig. 3 - Zone of convenience for storage

### 2.06 Spaces "in between"

Two benches spaced 86cm apart give just enough space for a student to pass sideways between the backs of two other students standing to work at the benches. In a science laboratory where a student may be handling a delicate instrument or working perhaps with hot liquids this is insufficient space. In the laboratories shown in this paper therefore, a minimum clear space of 1m. is allowed (Figure 4).

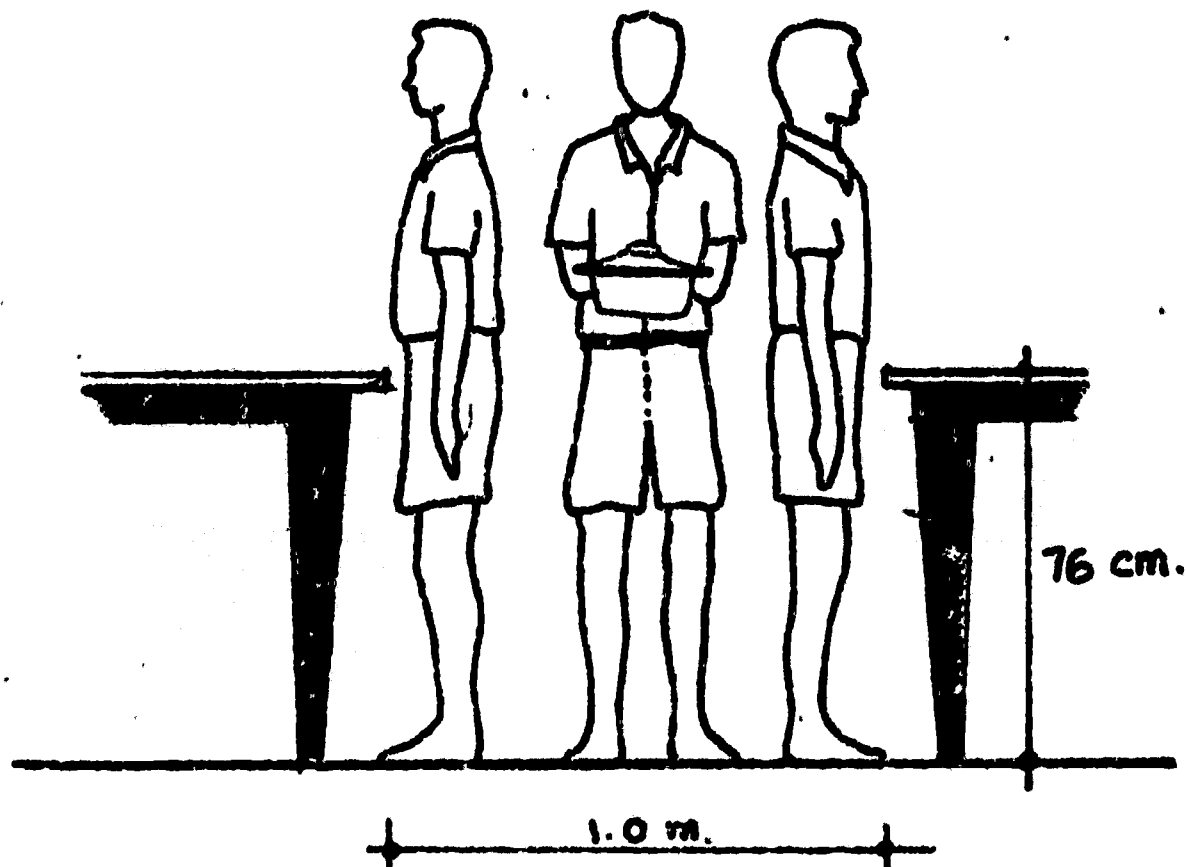

Fig.4 - Spaces between benches

### 2.07 Illumination in Physics and General Science Laboratories

Poor lighting in a laboratory may lead to early tiredness and lack of concentration as a result of which accidents, mistakes and breakages may occur. Many of the science laboratories in Asia are poorly illuminated although realisation of this fact is not common among those who use them due to the extraordinary capacity of the eye to adapt to conditions of under- or over- illumination.

Different minimum levels of illumination are required for different tasks. The finer the task, the higher the illumination level needed to perform it efficiently. Thus in a general science laboratory, much better lighting will be required for dissection work than for an experiment on, say, the triangle of forces.

There are widely differing views on the minimum acceptable illumination levels some of which are shown in Table II.

Where illumination levels for the precise application given are not regulated, the levels for the nearest similar application are given in the Table. Thus for India, illumination levels for laboratories are not listed; those for "sustained reading" have been given instead.

TABLE II - Minimum required Illumination Levels (in lux)  
in different Countries

ACCOMMODATION	C o u n t r y					
	S. Africa 4/	India 5/	Japan 6/	U.S.A. 7/	U.K. 7/	Sweden 7/
Classrooms	215	163	150	322	107	163
Laboratories	215	307	300	1076	156	

A consensus of the results would suggest the following illumination levels:-

Classrooms about 180 lux  
Science laboratories about 200 lux

Of course, where electricity is available it can be used to supplement daylighting to provide whatever illumination level is required. Probably over 80% of Asia's schools are in rural areas where electric lighting is often not available in schools. The three sections shown in Figure 5 indicate the levels of natural illumination that could be expected on the bench tops in laboratories with verandah, without verandah and with double-banked corridors. In each case the illumination level has been calculated in front of windows. Behind the columns between the windows it will of course be lower. Cill heights have been taken in each case at standing bench height, that is, 76cm above floor level.

4/ Rennhackkamp, W.M.H., *School Lighting*. South Africa. National Building Research Institute. *School Building Series*; Report, no.10. Pretoria, 1964.

5/ Indian Central Building Research Institute. *Building Digest*, no.40: *Fenestrations for Daylighting in the Tropics*, Part I - The Sky Component.

6/ Japan. Ministry of Education. Educational Facilities Division. *School Buildings in Japan* Tokyo, 1967.

7/ Rennhackkamp. *op.cit.*

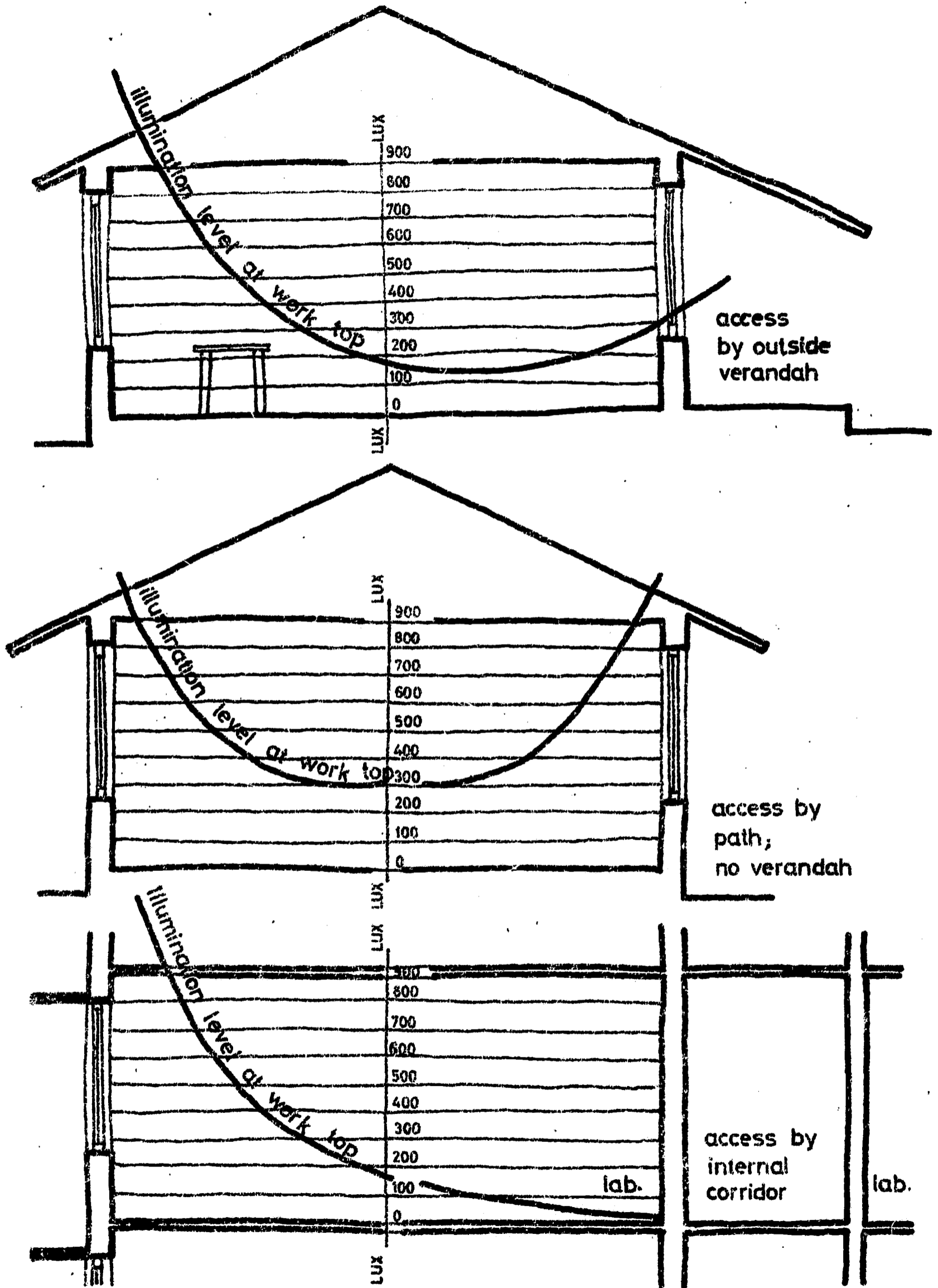

Fig.5 - Illumination by daylight in laboratories in differing cross-section



It is clear that less than half of a double-banked laboratory cannot be used without supplementary electric light and in situations where electricity is not available, double-banked laboratories should not be built. In addition to the poor illumination that results from their use they also present a very difficult ventilation problem in hot-humid areas.

The laboratory with verandah is commonly used in high latitude regions with the verandah towards the equator forming a sunshade. In this case quite good illumination is available on the side of the room away from the verandah but one third of the space although suitable for other purposes, could not be used for detailed measurement work. The verandah-less laboratory is the most suitable of the three alternatives. Not only is it cheaper but the illumination is more even over most of the section, at a level suitable for all purposes.

Illumination can be improved by as much as about 20% by the use of as much glass and as few glazing bars as possible, by regular cleaning of the glass and by the maintenance and regular re-painting or distempering of eaves soffites, ceilings and walls in light colours.

## 2.08 Thermal Comfort in Physics Laboratories

Perhaps the most important aspect of thermal comfort is that it is the child who is to be made comfortable and not the room. In the humid tropics where cooling is by evaporation of perspiration from the child's skin, the need is to direct the air-currents that speed the evaporative process at the child and not, as is so commonly observed, at the ceiling above the child's head.

Asia presents three general thermal comfort problems:-

- i) the humid zone problem;
- ii) the dry zone problem;
- iii) problems of the upland or cold zones.

It is only possible at present to generalise about these problems for first, there is little information on what people in Asia find thermally comfortable and, secondly, there are so many variable factors affecting thermal control such as wind direction, wind speed, cloud cover, insulation, humidity and the like that to date, no very precise methods have been devised of ensuring a thermally comfortable environment through building design - that is, of course, without the aid of air conditioning. Nevertheless, in both hot-humid and hot-dry zones certain simple steps can be taken to reduce the effects of the solar heat load. Basically, the smaller the area presented to the sun, the less the heat gained. This is compatible with present efforts to economise in the per place areas of schools. Thus, schools in low latitudes should be arranged with their narrow "ends" facing

the low, but hot, early morning and late evening sun. This means the "long" sides of the building will face north and south and, as the mid-day sun is high, its angle of incidence with the "long" walls will be low and the solar gain small. In single storey schools it may be kept off the walls altogether by overhanging roofs which are often, in any case, needed to exclude direct sunshine from the laboratory windows. (See Figure 5, middle section). Where laboratories are at the end of a building then it is a good idea to arrange the store on the end wall so that any heat transmitted will warm the store and not the teaching space (Figure 6).

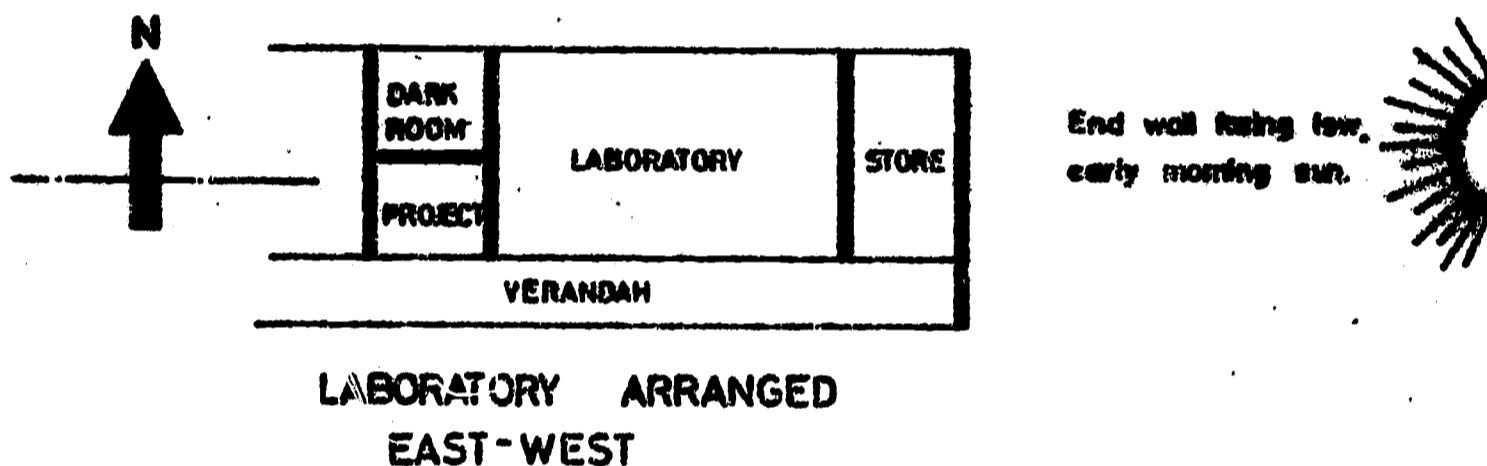

*Fig. 6 - Orientation of the laboratory*

As far as possible external finishes should be in very light colours as these in general reflect more radiant heat than darker finishes.

Brick and concrete work should be coloured white and, where a selection of materials are available for roofs, the lightest colour is to be preferred. Aluminium will transmit less heat, even when dusty, than clay tiles<sup>8/</sup> although tiles are to be preferred from this viewpoint to old and fungus-covered asbestos sheets.

There is one major difference between the design of laboratories for thermal comfort in hot-humid and hot-dry zones. In the hot-humid zones the cooling of the occupants of the laboratory is achieved by ensuring either that breeze passes through the laboratory or that turbulence is created; whereas in the hot-dry zones thermal comfort is better achieved by sealing the building against the sun.

8/

*Koenigsberger, O. and Lynn, R., Roofs in the Warm Humid Tropics,  
(Architectural Association. Paper no.1. London, Lund  
Humphries, 1965.)*

This air movement speeds up evaporation at the surface of the skin and gives a feeling of cooling. In order not to impede the passage of the breeze from one side of the room to the other it is essential that ventilation openings - usually windows - be presented to the breeze and that all high cupboards and division walls be arranged normal\* to these openings and thus parallel to the breeze (Figure 7).

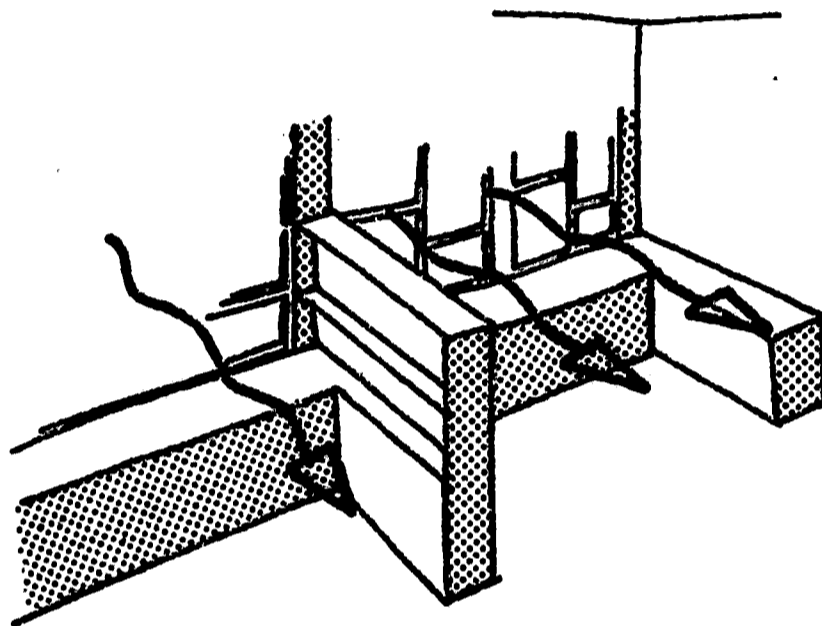

*Fig.7 - Arrangement of furniture for good cross ventilation*

On the other hand, in hot-dry zones, where air temperatures outside are so high that body heat cannot be reduced by respiration, then thermal comfort is best achieved by sealing the building early in the morning and reducing the rise of temperature inside by excluding solar heat. The location of furniture in a laboratory in these circumstances from a thermal comfort point of view is of little consequence.

There is also a need in the winter months in upland countries and countries with hot dry summer climates, to provide heating facilities for the winter. In Afghanistan, Korea and Nepal for example, snow is common and below-zero temperatures are frequently experienced. In the North of India and in West Pakistan, children are often taken out into the playground in the early morning to keep warm in the winter sun. Fortunately in these circumstances the "sealed" building, so essential in the very hot months when the heat need to be excluded, is also convenient in the winter when the heat needs to be "kept in". Various countries have various ways of heating classrooms depending on the construction of the building and the fuel available. In the design suggestions given in Chapter 4, space should be included for appropriate heating devices.

---

\* at right-angles to

CHAPTER 3

FURNITURE IN THE PHYSICS LABORATORY

3.01 General

Furniture in a physics laboratory has a more flexible rôle to play than in a chemistry or biology laboratory where tables and shelves rarely have any function other than that of housing services and providing a stable, level based on which to stand apparatus. Physics experiments, involving as they do, the study of mechanics, heat, light and wave motion etc., require furniture to which can be securely anchored, or from which can be hung, the ends of wires, blocks, pulleys, trolleys, batteries and the like. Sometimes experimental apparatus will be suspended from the edge of the table, on other occasions it may be cramped to it, whilst less frequently, small towers of equipment may be constructed requiring a firm fixing at the base. Physics experiments, perhaps more than those of any other science taught in second-level schools, lend themselves to invention and improvisation. The furniture in the physics laboratory must be designed to facilitate this so that the student can give free rein to his imagination in investigating the natural phenomena included in the physics syllabus.

3.02 Facilities required in the physics laboratory

A study of three physics teaching schemes shows the following requirements connected with furniture and services:-

TABLE III

Facility	% of experiments requiring the facility		
	Scheme 1 <sup>9/</sup>	Scheme 2 <sup>10/</sup>	Scheme 3 <sup>11/</sup>
Heat	1	3	17
Electric power *	20	44	19
Running water	0	0.5	0
Stable horizontal work top	60	24	61
Edge fixing to work top	20	5	0
Ripple tank	9	13	0
Ceiling hooks	0	0.5	0
Floor space (no furniture)	10	10	3

\* mains, battery or accumulator.

<sup>9/</sup> Educational Services Incorporated. Physical Sciences Study Committee. Physics laboratory guide. Boston, D.C. Heath, 1960.

<sup>10/</sup> Nuffield foundation. Nuffield Physics; guide to experiments. Pt. 3. Longmans/Penguin, 1967.

<sup>11/</sup> Ceylon. Department of Education. Syllabuses of instruction and scheme schemes of work in science subjects for G.C.E. classes. Colombo, Government Printer, 1965.

The facilities listed, of course, overlap. Experiments requiring heat or electricity also require a table top. It is clear that the designers of physics schemes rely heavily on the facilities that are available in the environment in which they work. Thus, for example, in Ceylon, as in most Asian countries, in rural schools there is frequently no main electric power source. The use of electricity has, therefore, been limited to that provided by torch cells or accumulators. The Nuffield Scheme on the other hand, makes considerable demands on electric power in the sections dealing with light, presumably because electricity is readily available in the areas for which the schemes are designed to be used.

Despite these differences of emphasis and approach, all three schemes have certain common requirements. Physics laboratories need provision for stable, horizontal tables at which there should be good facilities for clamping apparatus; electric power from cells, accumulators or from a main supply should be available at the table; there is evidently little need for running water and although heat is required, its application is infrequent; the laboratory should have floor space for general experimental work and for work with ripple tanks.

From this it may be concluded that there should be places for all students at tables which are provided with electric power and a few extra places at which water and gas or oil for heat for experiments are available when required.

The degree of improvisation and genuine experimentation required of the students in the new schemes of physics teaching are such as to suggest that the majority of student work tables should be movable.

There are, as will be seen below, other compelling reasons for mobile furniture if effective teaching is to be made possible.

### 3.03 The Laboratory

The traditional method of teaching physics involves a lecture explaining a particular principle and, in the following period, an experiment carried out by the students in which the principle explained in the lecture is verified. The lecture normally takes place in a classroom and the experimental work in the laboratory.

The new methods of teaching tend to reverse this process. The students, working in small groups, or as individuals, commence study of a particular topic through an experiment in which they endeavour to find out for themselves the principle or laws involved. At some suitable moment, when as much as is possible has been gained from the experiment, the teacher will initiate a class discussion in which the results of the various student experiments are studied and the outcomes of the experiment determined.

A good example of this type of teaching is given below:-

Young's Experiment:- Interference of Light Waves:

- Student Experiments - looks through two slits in a slide at a lamp.  
- sees dark and light bars - why?  
- sees bars near end of pattern coloured - why?  
- covers lamp bulb with red cellophane and puts ruler above it.  
- how to determine  $\sin\theta$ ?  
- what is the wavelength of red light? etc.
- Class Discussion - Teacher decides that time is ripe for discussion of students' work and results.
- Teacher Demonstrates - The differences between measurements of the directions of nodal lines using a ripple tank.
- Teacher shows film or recapitulates - A brief film or talk recapitulating the purpose of the lesson brings it to a conclusion.

Clearly it would be most inconvenient during such a lesson to move backwards and forwards between classroom and laboratory because the nature of the lessons alters - from experiment - to discussion - to demonstration - to film. The students can in these circumstances best remain in the laboratory and arrange themselves, their chairs and their tables as conveniently as possible in relation to each change in activity as it occurs.

Every lesson will not necessarily follow the pattern outlined above. Some periods will simply comprise experiment and discussion, others a demonstration followed by a film or an experiment followed by a demonstration. Whatever the variation, it will invariably be found more convenient for the students to remain in the laboratory and to adjust the position of the chairs and tables so that they can most effectively participate in each new activity.

To facilitate this it is important that the physics work tables be designed so that they can easily be moved and the laboratory quickly arranged in the most appropriate way to suit the various phases of the lesson.

This is not to suggest that all physics teaching must be conducted in a laboratory<sup>\*</sup>. For example, a lesson on Total Internal Reflection might involve no experimental work but simply round off earlier lessons dealing with light at the boundary of two substances and develop, possibly through graphical exercises, a qualitative familiarity with total internal reflection. The equation for critical change can then be established.

---

<sup>\*</sup> It is worth noting, however, that in the Nuffield Schemes for Chemistry and Biology, all the programmed work is in the laboratory.

Such work can easily be undertaken in an ordinary classroom and will occupy one or more periods during which students will not find it necessary to move either themselves or their desks.

### 3.04 The Student Work-table

The design of the work-table to be provided for all students in the physics laboratory depends on the grouping of students for experiments and the minimum dimensions required for experimental work. Shape, stability, provision of services and the materials of construction are also of fundamental importance. The type of bench finally selected will, moreover, have a major influence on the total area of the laboratory.

#### a) Grouping of students

The ideal group for most physics experiments comprises two students. Indeed many experiments would be difficult to carry out single-handed.

On the other hand large classes of up to 50 coupled with a shortage of apparatus are, likely to remain a feature in many Asian schools for some time to come and in such situations groups of two students per experiment would be impracticable. The maximum size of group that can work reasonably, with every student given an opportunity to make individual observations, may be put at four and it is towards such a grouping that this study assumes most educational authorities will be directing their efforts in respect of the supply of physics apparatus (Figure 8).

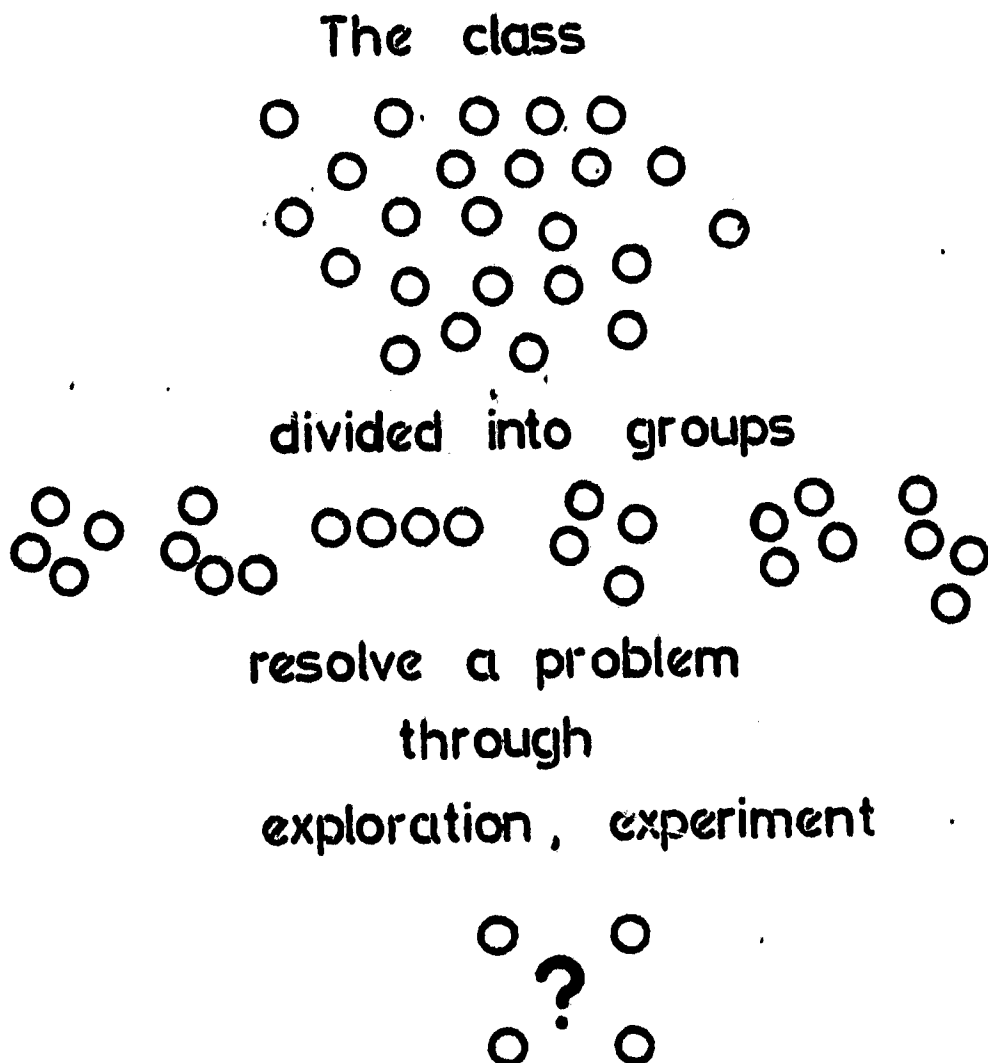
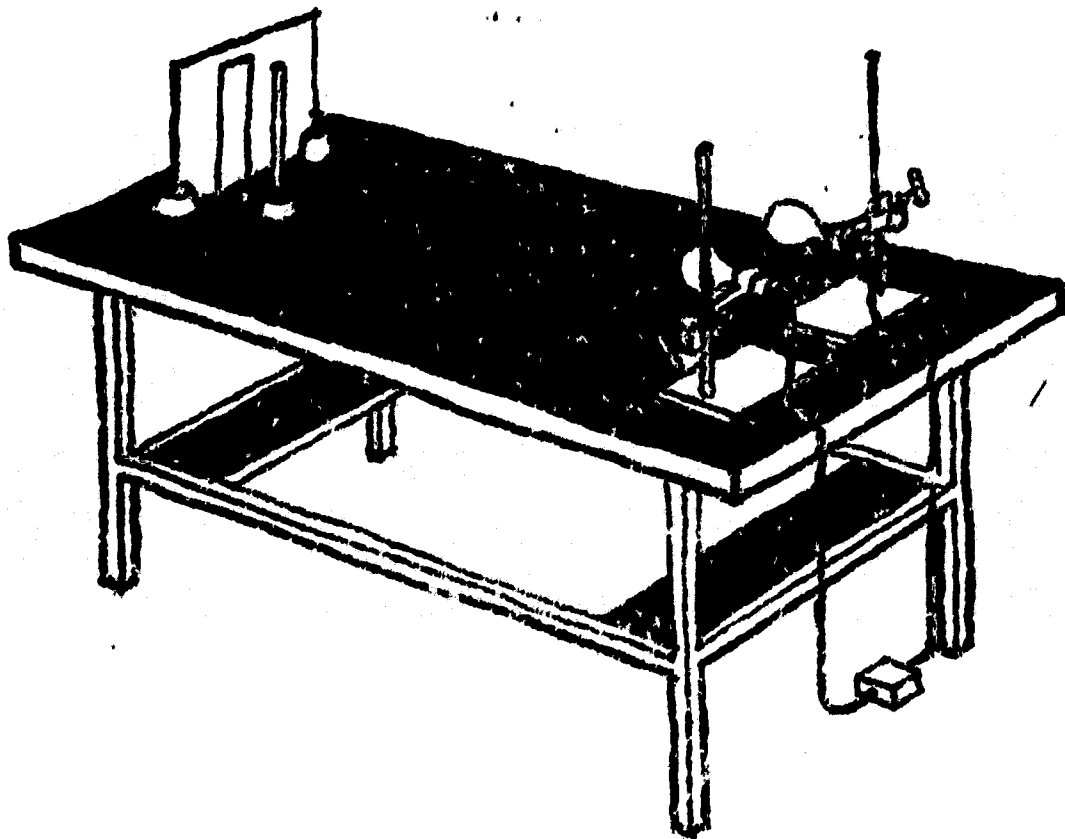

Fig. 8 - Grouping of students in the Physics laboratory

b) The shape of physics experiments and size of working surface

Biology work is characterised by the almost square dissection tray, chemistry experiments tend to centre on bunsen burners and beakers and at elementary level are round in character. Work in physics tends if anything to occupy long, thin, rectangular areas of bench. Studies of light, for examples, are lineal involving sighting in straight lines through lenses (Figure 9).

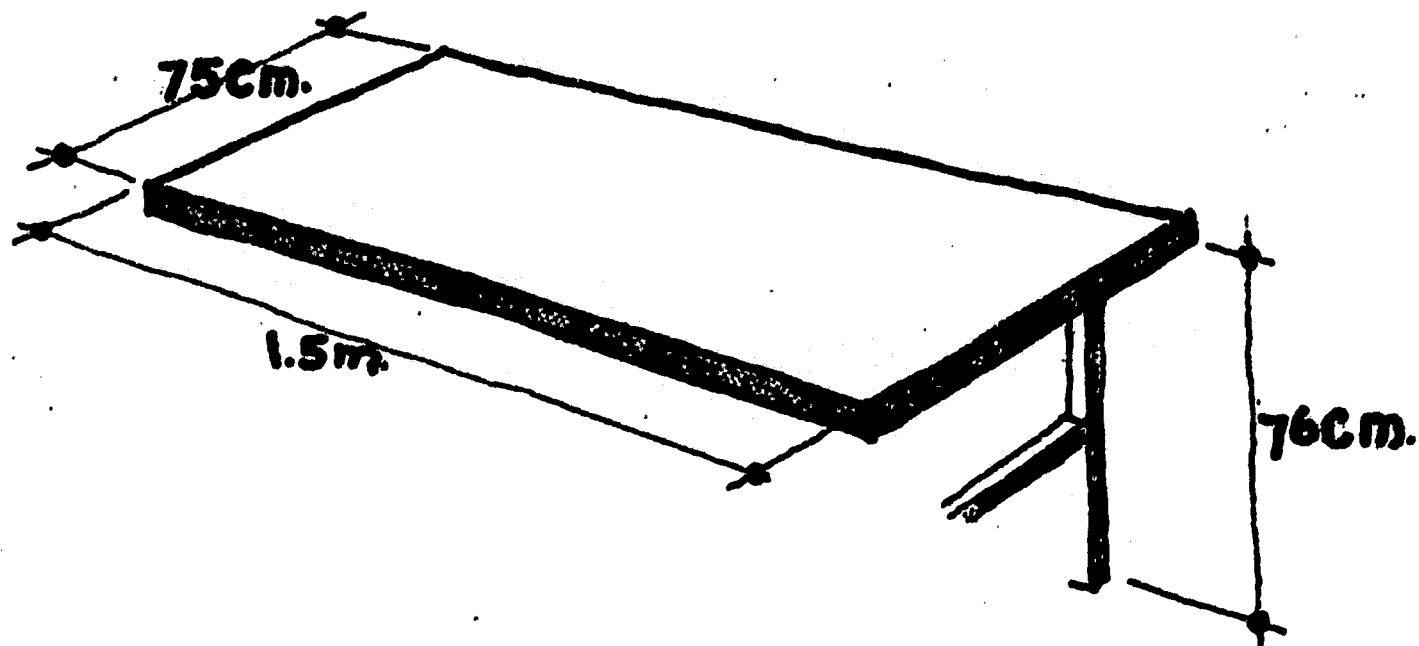

*Fig.9 - A typical Physics experiment occupying the full bench length*

Studies of forces are also lineal in character. An examination of the three physics teaching schemes referred to above shows six student experiments 1.5m in length and a number of others requiring almost this length of bench.

The dimension determined for the working surface of the free-standing students' bench is thus 1.5m x 75cm (see 2.03 above). This for 4 students in the 14 to 18 year-old group, will be located at standing work table height, that is 76cm above finished floor level (see 2.01 above)(Figure 10).





*Fig.10 - The working surface for a movable student's bench*

In addition to the space required for experimental work, however, it will be necessary to provide surfaces at which the students can record the results of the work they are doing. No experiment will occupy the whole of the table and it may reasonably be assumed that two of the groups of four students will find space on the table for their notebooks. The other two students may be provided with "pull out" shelves for writing - similar in character to those commonly found at typists' desks (Figure 11).

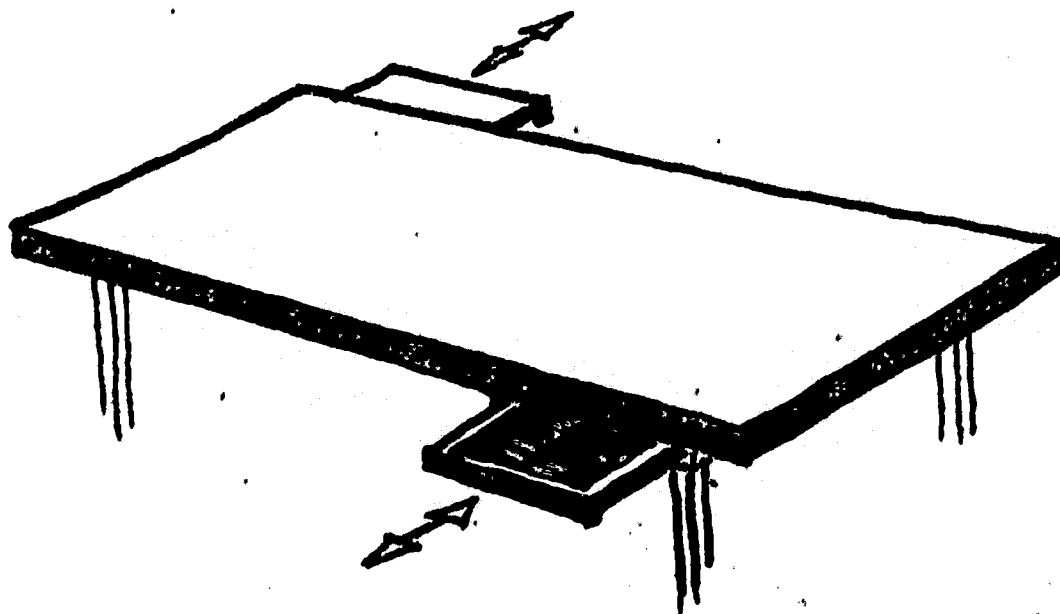

*Fig.11 - Pull-out writing surfaces*

The projection of these shelves should not be such that students can exercise an overturning moment on the table, which must be stable.

c) Fixing to the table

A number of experiments - as will be seen from Table III require cramping to the edge of the work surface. Small joiner's cramps are often used for this purpose. The work surface should thus project about 10cm free of any supporting rails all round the table top (Figure 12). Where cramps are used then the table top should be of hard wood or other material able to resist indentation.

d) Electrical services

As has been explained in 3.02 above, the students' physics table should be movable. Fortunately the majority of experiments involving the use of electricity require direct current and this can most easily be provided from

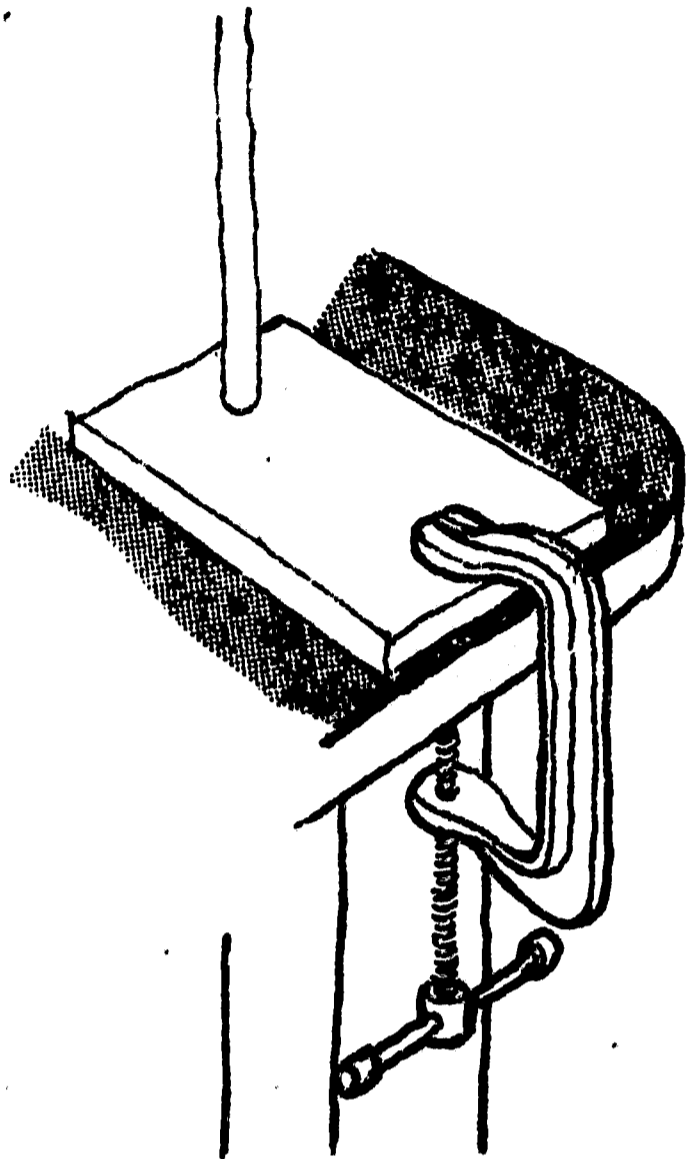

Fig.12 - Cramping to the working surface

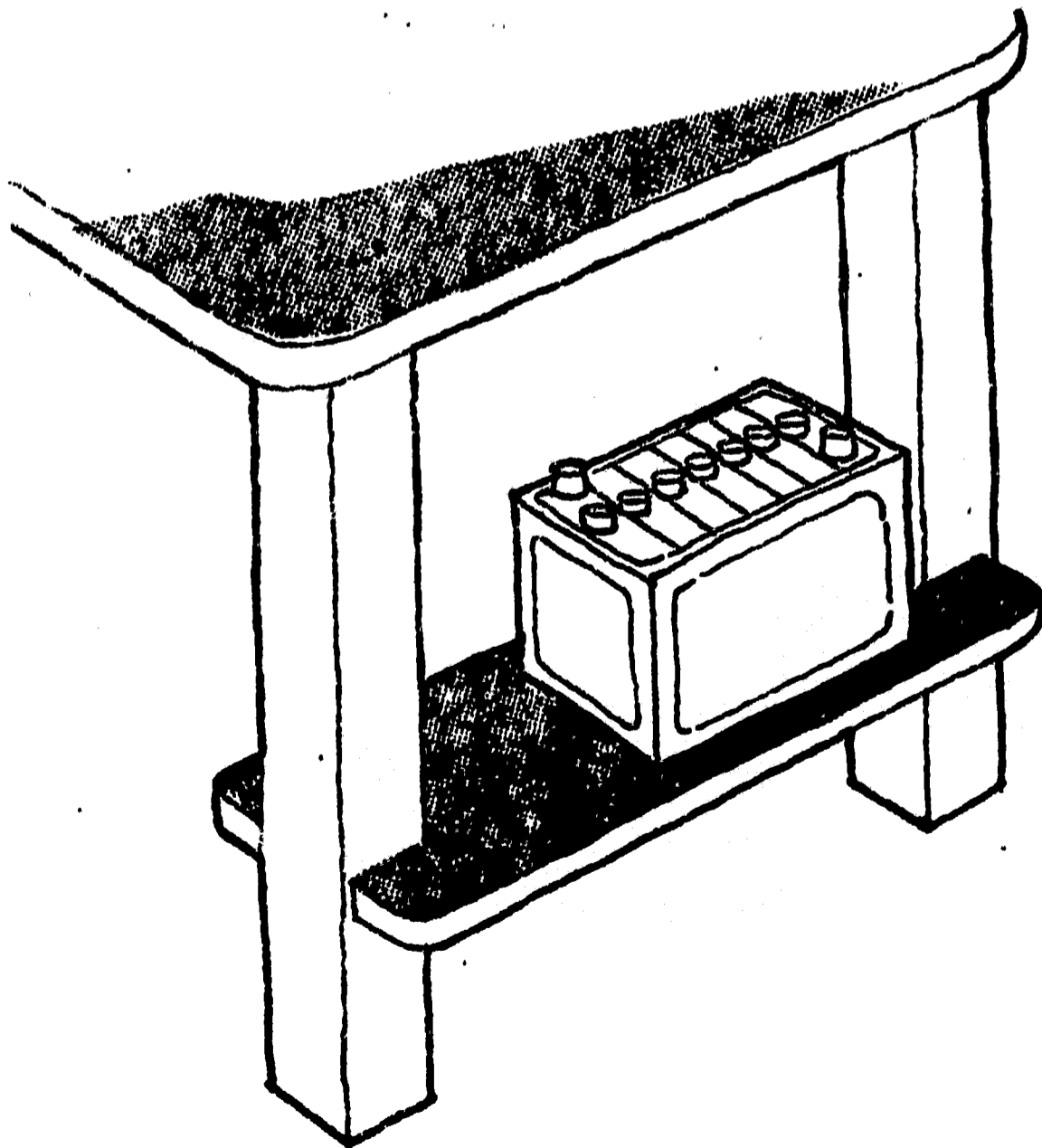

Fig.13 - Accumulator storage shelf

accumulators or torch cells. Torch cells can be used on the work surface but accumulators can better be stored under it and connected by leads to the apparatus on the work top (Figure 13).

Alternating current, when it is required, can be provided by cables from outlets arranged at convenient points either around the walls of the laboratory or from socket outlets in the floor.

As part of this Study, a prototype physics table incorporating the features outlined above was made in the Institute and is shown in Plates 1 and 2.

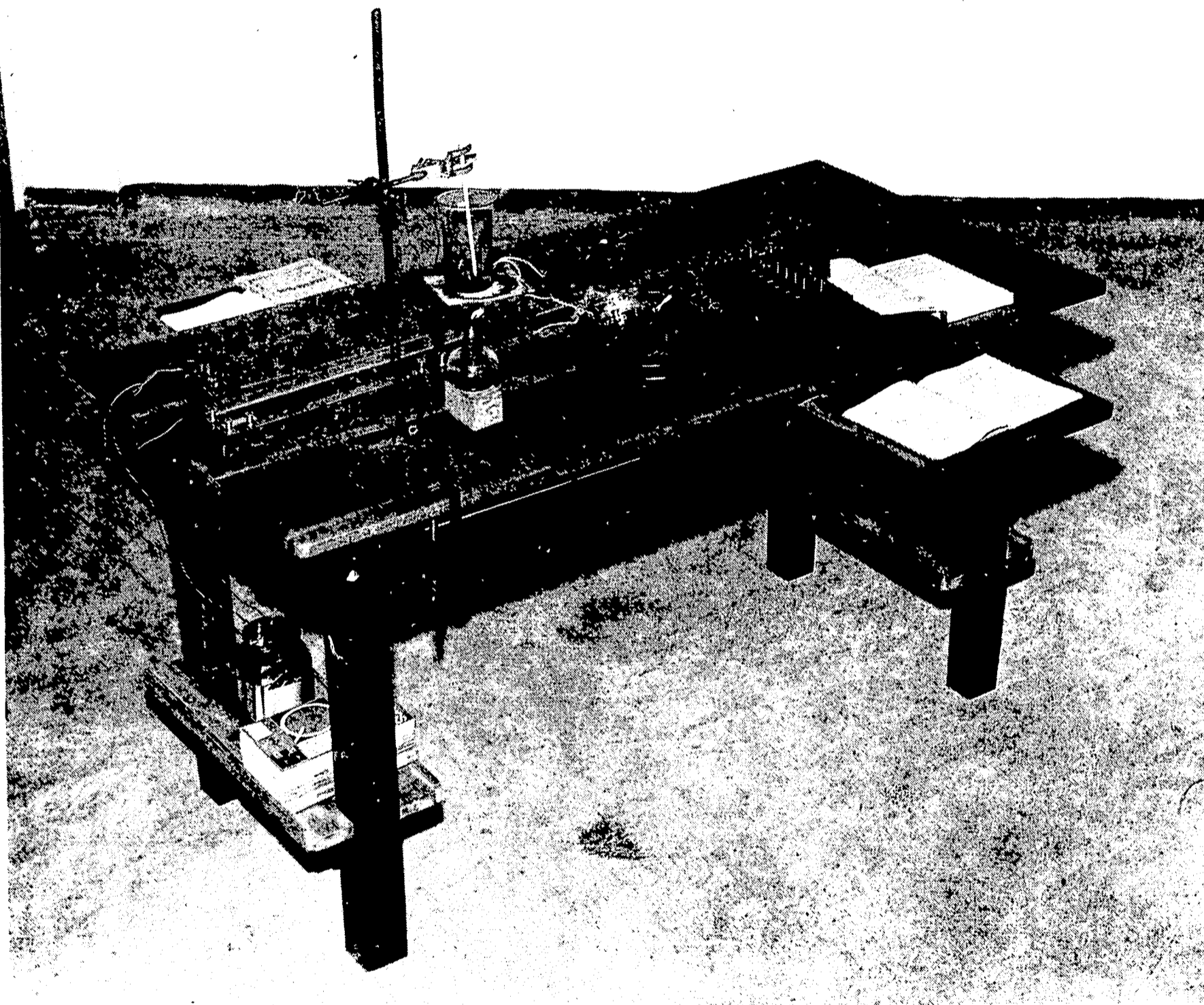

Plate No. 1

View of prototype Physics table for 4 places.



Plate No. 2

An experiment set up on the Physics table using a cell battery.

### 3.05 Wall-fixed work-tables

As has been explained above, some experiments require heat, water or mains electricity. They represent only a small percentage of the total experimental work but, nonetheless, provision must be made for them and this is best arranged at wall benches in which can be set sinks, gas taps and power outlets. Where gas is not available then electric heaters or primus stoves will be the usual alternatives. A primus stove is certainly best located on a fixed bench where it is less likely to be knocked over.

The work-table itself should not be wider than 50cms - this being the maximum comfortable forward reach of a 14 year-old (see 2.03 Sitting and Standing). It will be fixed to a cross wall or along the length of the laboratory preferably under a window. At least one sink (but preferably for a class of 40 about four) should be set in the table-top. Glass-fibre sinks are to be preferred to ceramic sinks as they are less likely to cause damage if glassware is dropped in them.

In schools where main water supply is not available then a tank, filled daily by hand, or by rain-water from gutters in the roof can be provided inside or outside the building at a level sufficient to provide a head of water at the taps. If it is not desired to provide expensive, piped water services then (as is suggested in Study No.3 of this series, The Design of Chemistry Laboratories for Second-Level Asian Schools) a 3-litre aspirator can be placed by each sink and filled from time to time with a bucket of water drawn from the nearest well.

Where mains power is available, earthed, 13 amp. A.C. outlets should be provided on a scale of about one per four students with gas outlets on the same scale (Figure 14).

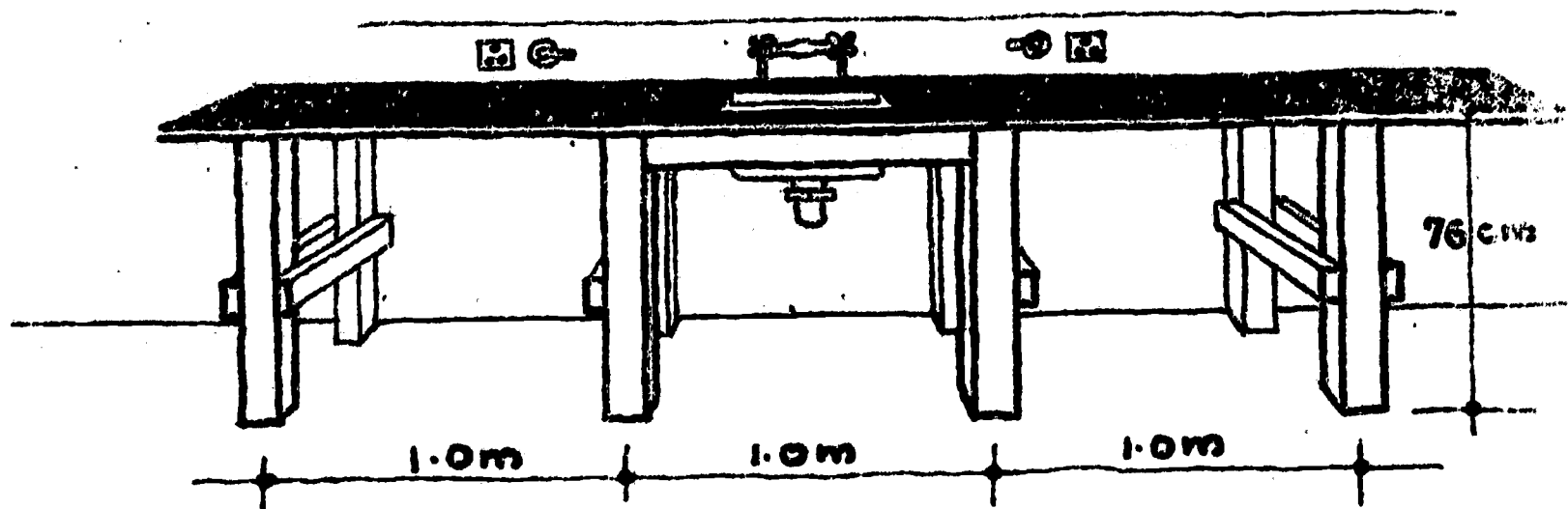

Fig.14 - Continuous work-table fixed to wall

The total length of fixed bench provided is difficult to determine exactly. Most teachers, however, are of the view that the more fixed benching available, the better and thus in this study, it is suggested that all wall space not occupied by other furniture, should have 50cm wide continuous work-table fixed to it.

### 3.06 Fixed work-table storage units

Storage at the fixed work-tables should be either above or below the table surface and within the "zone of convenience" (see Figure 3). This means that wall cupboards can be hung above to a maximum height (to bottom shelf of cupboard) of 1.25m above finished floor level and below the table top to 39cm above finished floor level. Figure 15 suggests the pattern that might result. Two different types of under-bench units can be provided, one with drawers, the other with a cupboard.

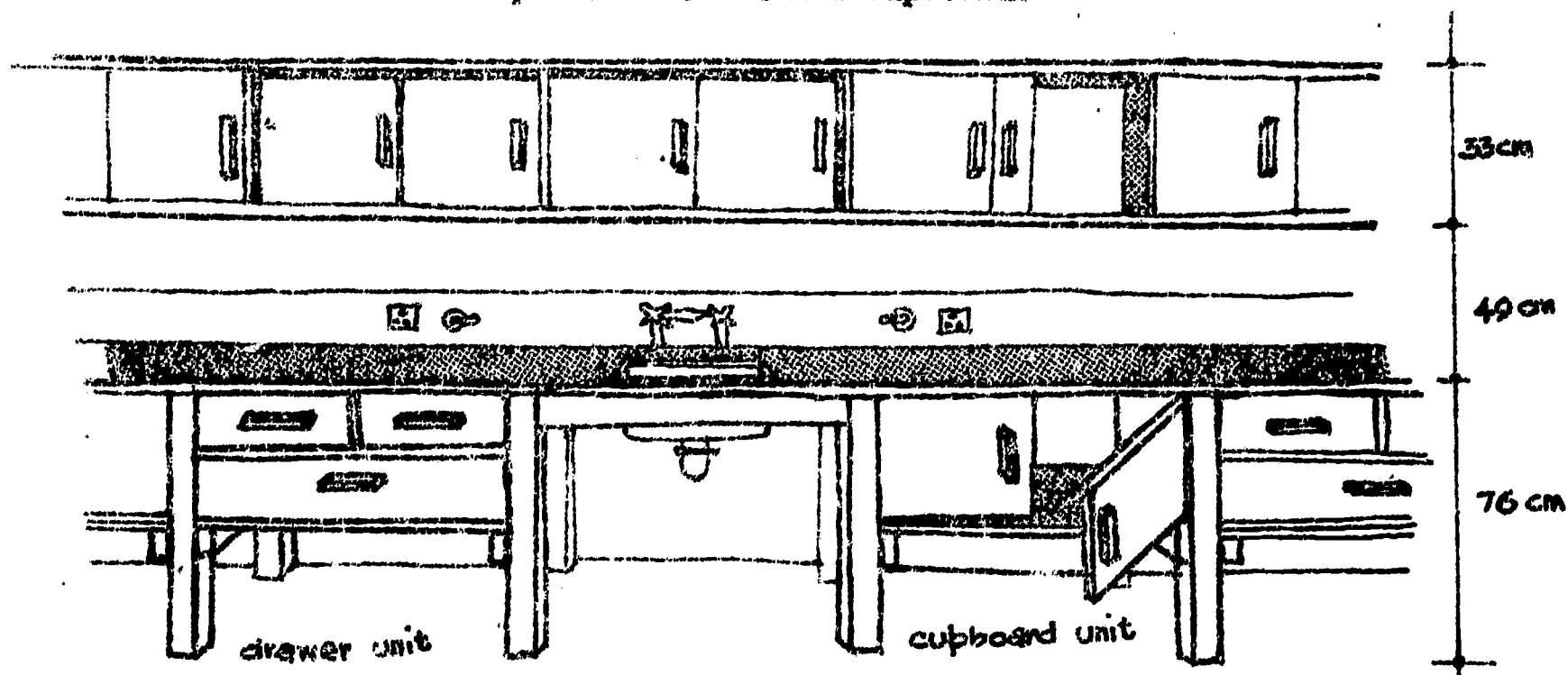

Fig.15 - Storage at the wall-fixed work-table

It should be noted that the old type of full-depth cupboard under the work-table is not recommended. Inspection of many of these cupboards in existing schools shows that due to the difficulty of reaching down into them, they are often, at best, unused and at worst, filled with rubbish. "Out of sight - out of mind" perhaps best describes this traditional situation.

The under-bench storage units, it will be seen, due to their "modular" size, can be slid in under the fixed table-top at strategic points. On the opening of a new laboratory there may be little to store other than those items of equipment comprising the official first issue. As work in the laboratory proceeds, more equipment may be constructed by the students themselves. As this occurs and the need for storage grows, new units can be added either under or over the bench.

### 3.07 Store access unit

Most of the equipment used in a physics laboratory will be kept in a separate store adjacent to the laboratory. This store will, be linked to the laboratory by a door but it may be found more

convenient for the teacher or where appointed, the laboratory attendant, to issue equipment through a hatch thus excluding the students from the store itself. This will be found more important where classes are large and where it would be impossible for every student or even for group leaders to enter the store without creating confusion.

The hatch should be provided with a counter at normal bench level (76cm. above floor level) which may be part of a normal fixed work table (see 3.05 above). The hatch should be 1m wide and high enough to provide a clear view for an adult from store to laboratory. The hatch needs also to be provided with secure doors (Figure 16).

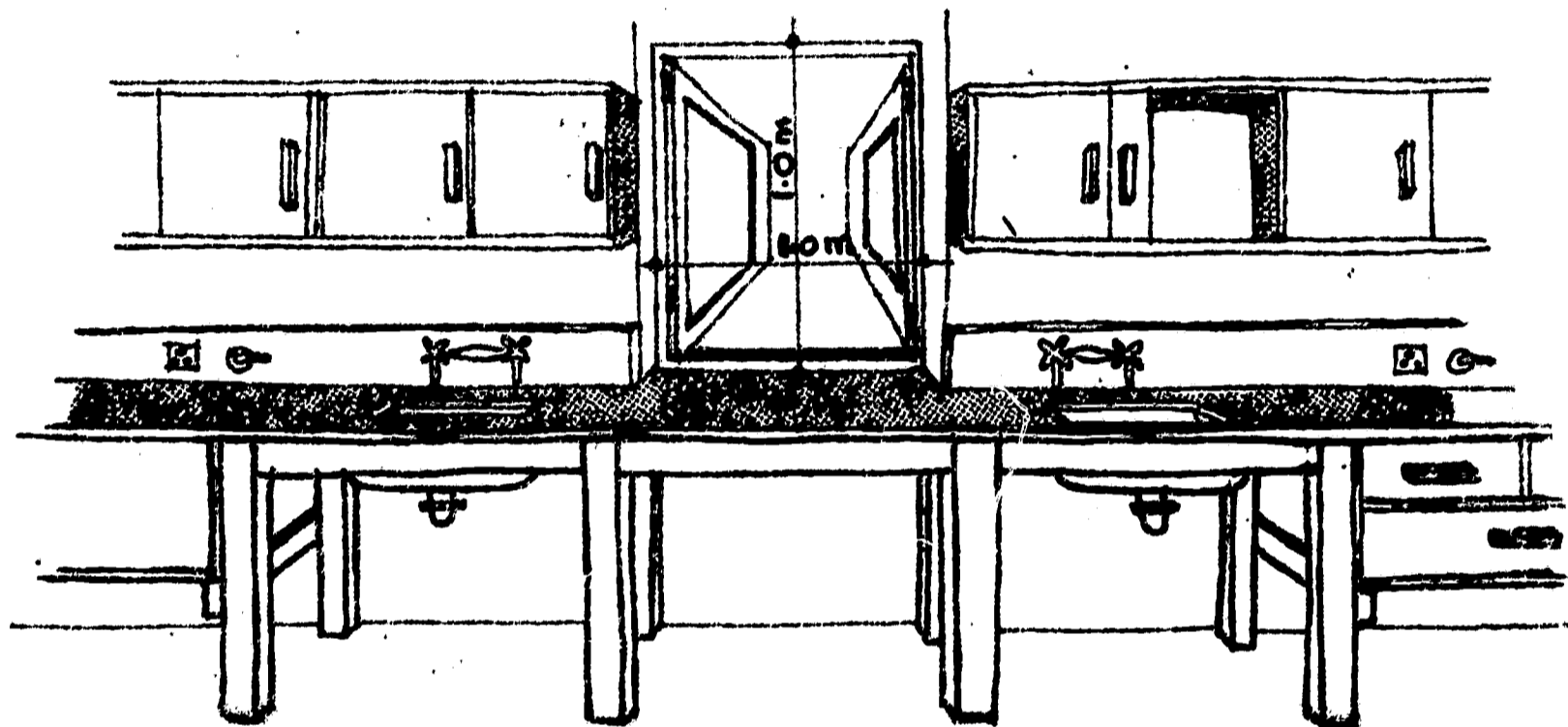

*Fig. 16 - Store access hatch .*

### **3.08 Project work-table**

The space for individual or group project work should be finished with a fixed wall-type unit with under-table-top cupboards and drawers. Gas and A.C. should be available. Above the table and fixed to the wall a tackboard will be found most useful in assisting the students either to hang apparatus or to pin up the plan of the project or data connected with it, such as graphs of readings (Figure 17).

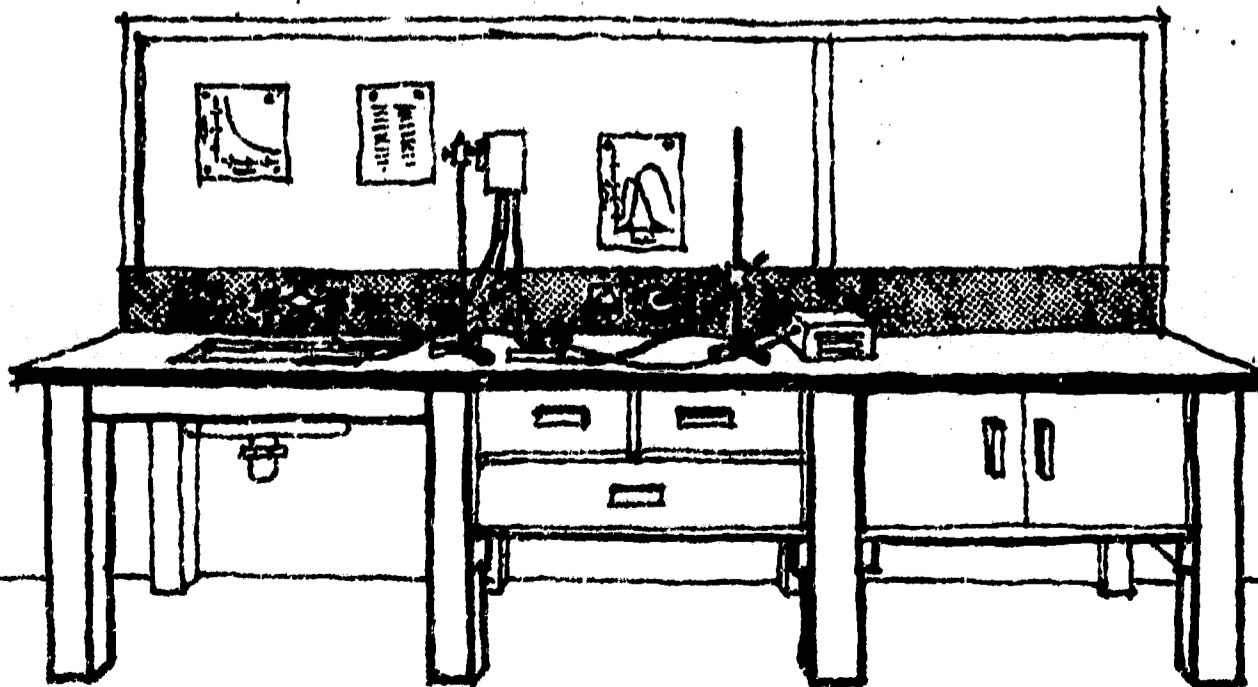

*Fig. 17 - Project work table*

It should always be possible for those not actually working in a project to obtain from inspection of it and from material posted on the tackboard, a clear idea of the aims of the project and the progress achieved to date.

### 3.09 Utility table

Good physics teaching will encourage students constantly to watch out for samples or newspapers and magazine articles connected with their laboratory work. For example, as interest develops in that part of the syllabus dealing with electricity and magnetism, they may, from time to time, bring in parts from radio sets and old cars. Old lenses and the like may be used during the section dealing with optics. The skilful teacher who attempts to relate the principles being taught to these everyday articles should be provided with a small table and tackboard at which displays of the article and related literature can be arranged. In addition to this student activity, the teacher will often arrange a special exhibit of apparatus and literature connected with each particular section of the physics syllabus as he teaches it.

Probably two or three bays of the standard fixed work-table will be sufficient for this purpose, behind which an area of tackboard can be provided on the wall.

### 3.10 Ancillary furniture

#### a) Students' book and bag storage unit

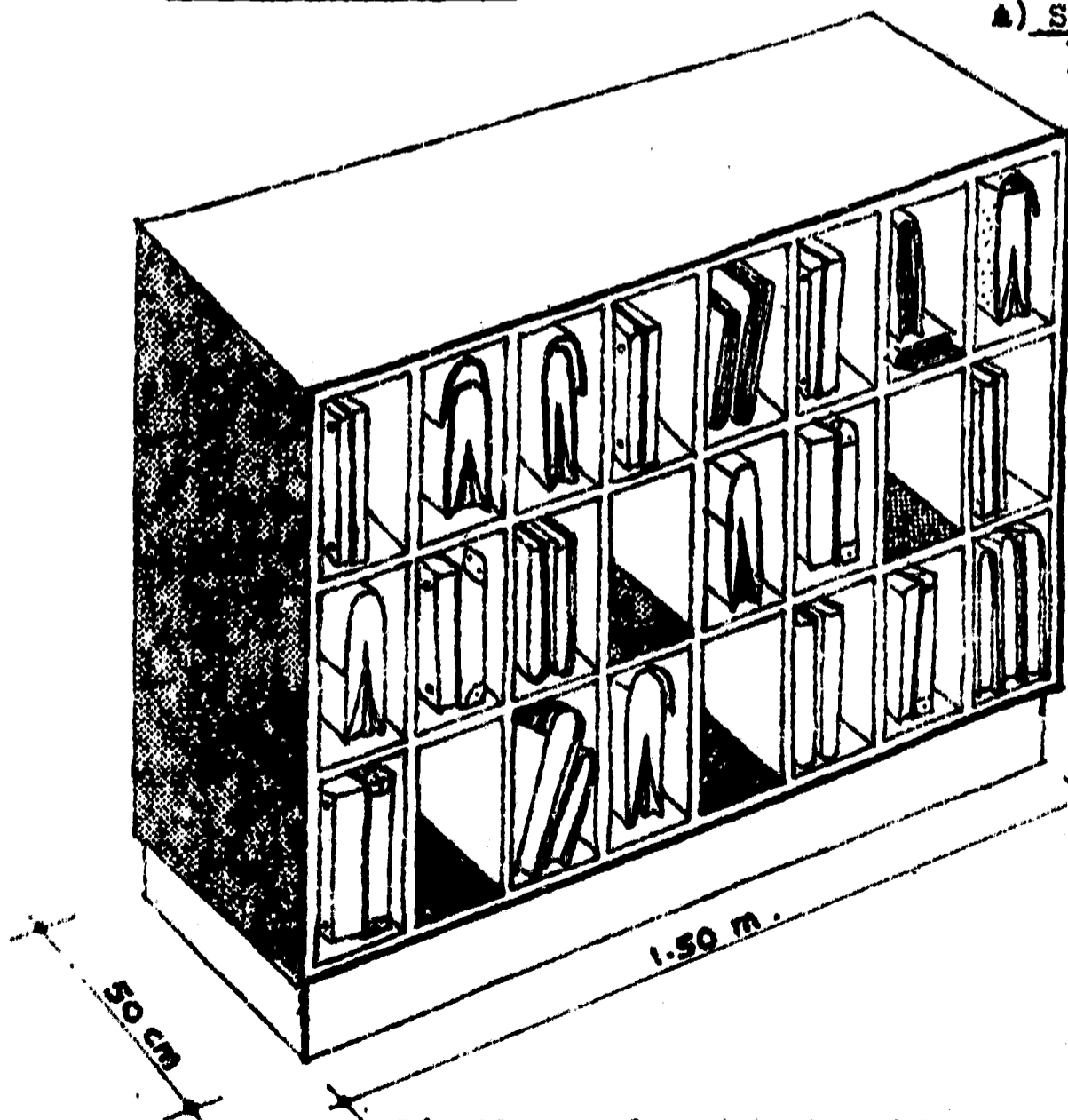

Most students will come to the library with a small stack of books or a case or bag. The rest of their books and bags will be a nuisance to them during the physics period and a book and bag storage unit should be provided near the door of the laboratory at which they can leave those items not actually needed for the lesson.

Fig. 18 - Students' book and bag storage unit



b) Book and periodical shelves

The importance of guided reading has already been mentioned in Chapter 1. A simple movable periodical rack is suggested. This can be arranged on a fixed table-top and a single shelf for books slid in underneath (Figure 19).

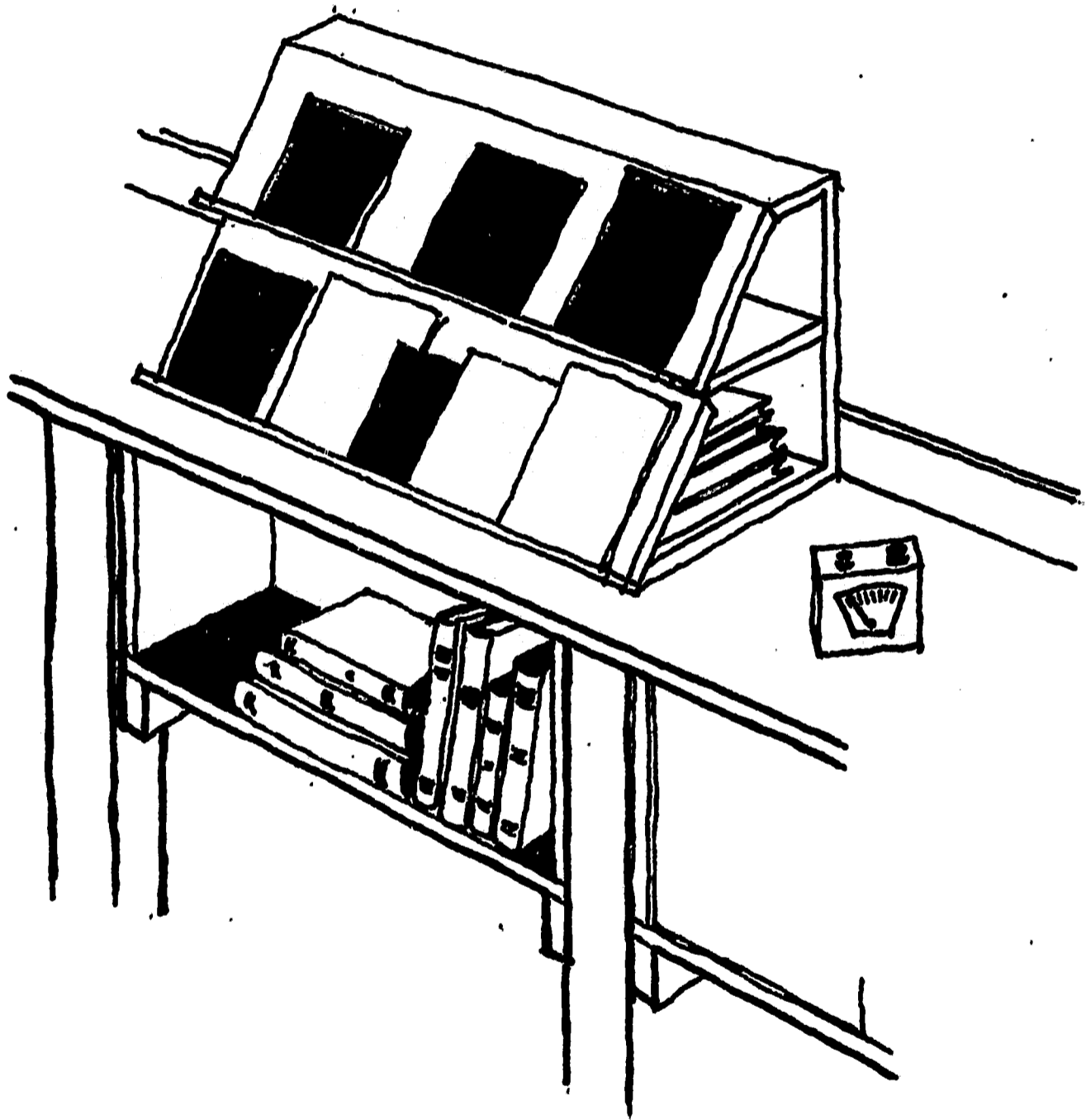

*Fig. 19 - Book and periodical shelving*

c) Chart cabinet

Charts and printed diagrams are of great value as aids to the teaching of physics. There are many storage cabinets available for this equipment but the type illustrated in Figure 20 has been found very convenient. The charts are hung from their rollers in a drawer-like frame from which it is very easy to select the particular chart required. Above the frame, opportunity is taken to provide flannel or tack-board for other visual aids. Sizes are not given in the figure as these will vary from country to country depending on the size of the charts used.

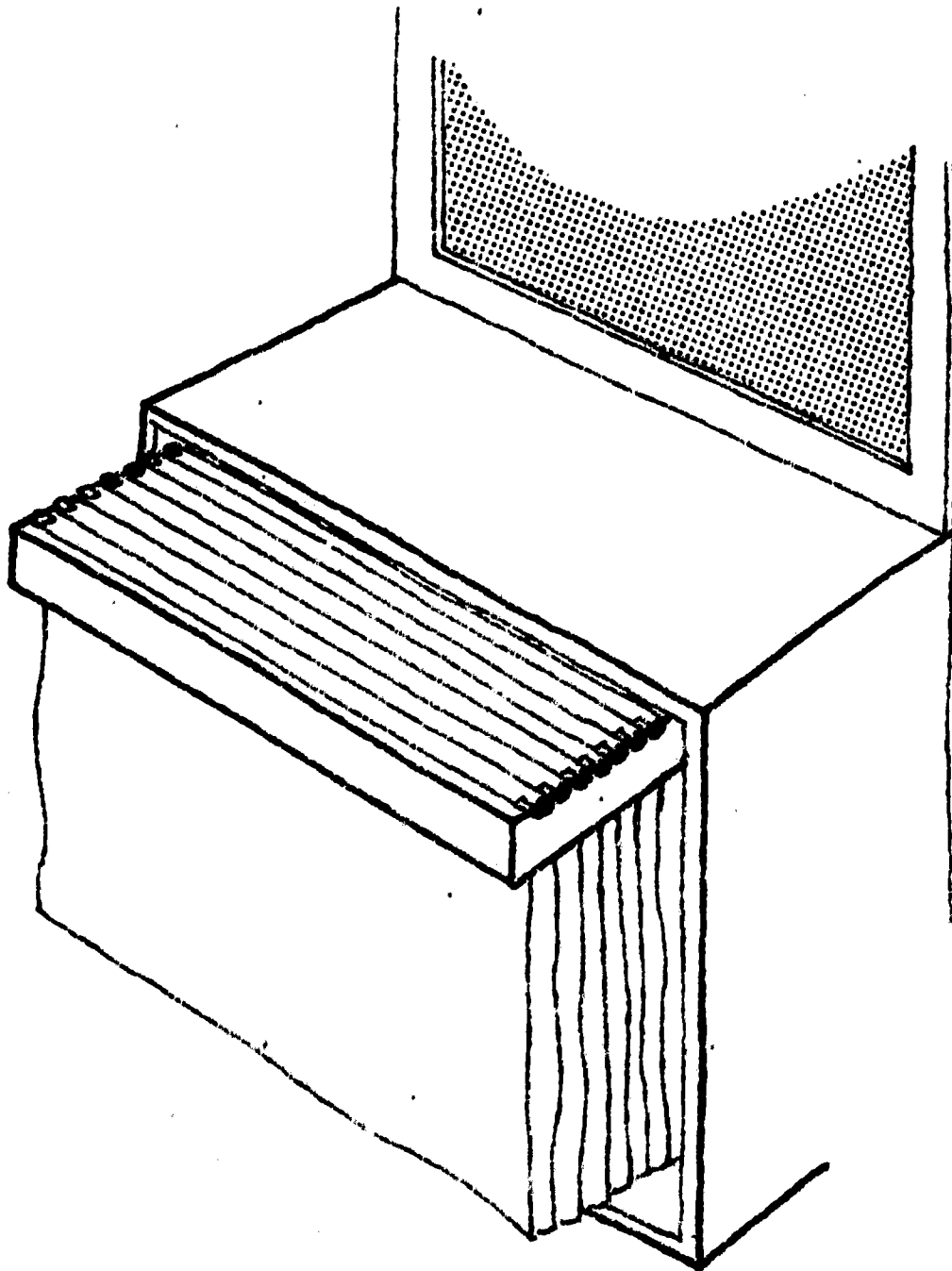

Fig. 20 - Chart cabinet

### 3.11 Teacher's Demonstration Bench

Laboratory work fluctuates between student experiments, demonstration by the teacher or students and discussions. The demonstration by teacher or students and the discussions will tend to focus around the teacher's demonstration bench. This bench, because of the comprehensive functions it has to perform, must be provided with all available services, i.e. gas, water, A.C. and D.C. The bench should be slightly larger than would normally be required for a student experiment. It should also contain storage space for several made-up experiments as during the course of one lesson, the teacher may give two or three demonstrations using different sets of apparatus.

It is important that the demonstration bench be easily seen by the students who are watching the demonstration. This can be arranged in two ways: first by raising the demonstration bench on a platform; secondly by arranging the bench at floor level with space near to it for the students to gather around it. The old idea of putting the teacher up on a platform is fast dying and most teachers find it more conducive to good teaching to be in closer contact with the students. The bench, which is shown in Figure 21, is 2m long and 75cm wide and the height is the standard bench top height, i.e. 76cm. The surface of the table should contain two sockets into which can be screwed metal posts that may be used from time to time as fixed retort stands.

Another piece of equipment, shown in Figure 21, that is extremely useful in the laboratory is a wheeled cart. This should be 50cm x 75cm and its height should be the same as the standard bench height, i.e. 76cm. The cart may serve several purposes. As shown in the figure it may be used to provide additional length to the demonstration table. It may also be used to wheel apparatus about the laboratory. Finally it provides a useful stand for a film-strip or other projector.

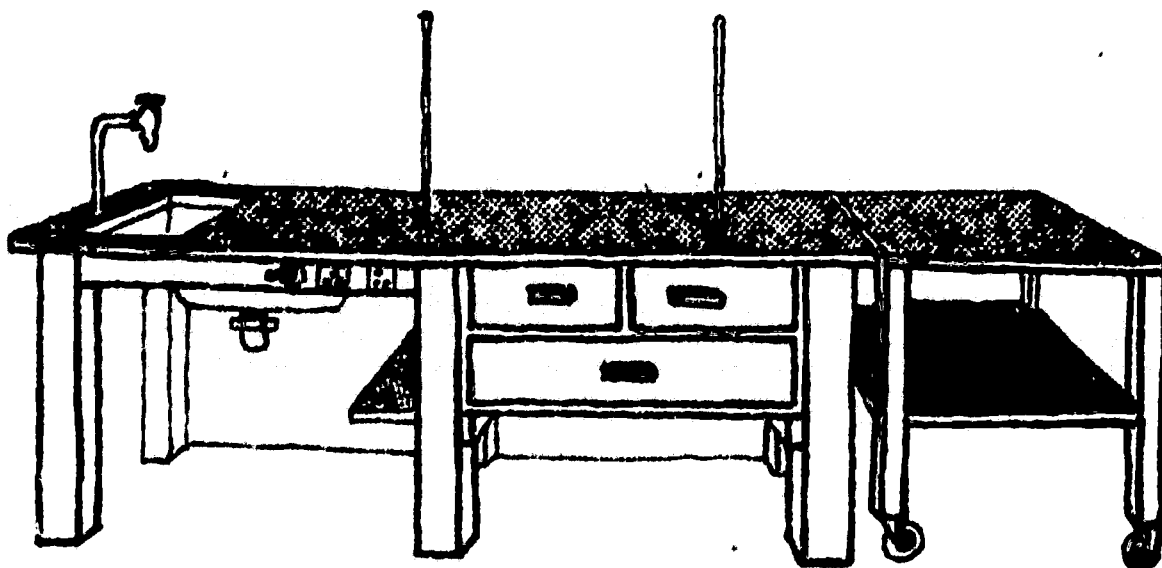

Fig. 21 - Teacher's demonstration bench

## CHAPTER 4

### The Design of Physics Laboratories

#### 4.01 The Design Problem

The design of physics laboratories for the Asian Region is a complex problem. In the first place the methods of teaching currently in use in the Region vary greatly from country to country. In some states traditional methods of physics teaching are deeply entrenched whilst in others the most up-to-date ideas are being used. In all countries the design of physics laboratories tends to lag behind the changes in physics teaching and indeed those who are working in schools having traditional laboratories frequently find that the rigid laboratory furniture layout seriously interferes with any attempts that may be made to introduce new teaching methods.

The second design problem which arises in considering the Asian Region as a whole is that of design for climate. Laboratories in hot-humid areas require good cross ventilation if the students and teacher are to remain thermally comfortable. This means that all storage cupboards have to be placed on cross walls, parallel to the breeze in order for air to flow from one side of the laboratory to the other. In other climates, either very hot or very cold, but dry, the reverse is the case. In such situations there is a need to exclude external breezes from the laboratory in the winter in order to keep the occupants as warm as possible and in the summer, to exclude very high temperature, air and dust.

The third problem concerns illumination and this is to some extent linked with the problem of design for climate. It is also connected with the urban-rural situation in Asia. 80% of Asia's school-going population live in rural areas where electric light is the exception rather than the rule. In such situations the laboratory will have to be lit entirely by daylight. This does not present a problem in the humid zones where, as described above, the demand for cross ventilation requires windows on either side of the laboratory. In hot-dry and cold situations, however, where it is necessary to exclude the breezes from the laboratory, then normally physics laboratories will form part of double-banked buildings, that is to say buildings having a central corridor with rooms on either side. These rooms will, therefore, be lit from one side only, receiving little other than reflected light. Figure 5 in Chapter 2 suggests that to obtain satisfactory illumination from daylight in such circumstances is extremely difficult.

Another problem in laboratory design is related to the Asian situation in which, as mentioned above, the majority of physics laboratories are unlikely to have electric power, gas or piped water.

Finally, it is necessary to consider the diversity of class sizes. In urban areas where science teaching is well developed and the opportunities for a child with education in science subjects are obviously very much greater, classes will be large. Physics classes of from 40 to 50 children are very common indeed in many of Asia's larger cities. On the other hand, in rural areas where science teaching is still slowly developing then it may be on occasion difficult to find a class of as many as ten children in certain areas, whilst 20 is a very usual number. There is thus a need in considering design for the Asian situation to provide for large and small classes and in this paper laboratories are offered for teaching groups of 20 and 40 students. Most physics teachers would probably regard 20 students as an ideal group from the point of view of size. As more science teachers are trained and more schools built then it may be confidently expected that the size of the very large teaching groups will slowly reduce. Some of the laboratory designs for 40 students shown later in this chapter may be thought rather cramped. In this connection however, it should be remembered that if the pupil/teacher ratio decreases in the future, then these suggestions for large laboratory designs will become very comfortable for smaller teaching groups of say 30 to 35 students.

#### 4.02 The Solution

The laboratory is little more than a shell enclosing space for physics teaching activities. The total space, in fact, needs subdivision into smaller spaces such as stores, dark-room, preparation cum project room and the laboratory proper. The size of these spaces will be determined by the functions they each individually perform. Thus the store must be large enough and of the right shape to contain all of the standard physics apparatus and to permit of easy access to it. The dark-room should be sized to allow a group of students and the teacher to carry out experiments in optics and the development and printing of films taken in connection with part of the syllabus dealing with motion. The teacher's room should provide space enough for the teacher to prepare material and to house a small group of students working on projects. The laboratory itself must be the most flexible of all spaces for, as indicated in Chapter 1, it may be used for discussions, demonstrations and a wide variety of experimental work.

The actual dimensions of the spaces will thus depend on the activities. All of the activities involve the use of furniture the sizes of which have been determined in the preceding chapter. Some notion of the total size of each space can thus be gained by considering furniture and making allowance for suitable circulation about the various benches and chairs.

i) Space in the laboratory, excluding ancillary rooms -  
for a teaching group of 40

10 group work-tables	43.8 sq.m.
40 chairs arranged for discussions	9.6 " "
20 bays of fixed wall-bench	20.0 " "
1 teacher's demonstration table	7.9 " "
1 chalkboard, chart cabinet	4.5 " "
1 students' book and bag unit	2.3 " "
Allow 10% circulation space	9.0 " "
Total say	<u>97.0 " "</u>

This is a laboratory area of about 2.4 sq.m per student place and compares favourably with the plans proposed in this paper which range in area from 70 to 96 sq.m.

It is of interest at this stage to compare these areas with those from some of the standard physics laboratories in the Region listed below:

India	1.49 sq.m. (1.99)
Hongkong	2.58 " " (3.09)
Ceylon	1.74 " " (2.24)
Singapore	3.00 " " (3.50)
Pakistan	2.17 " " (2.67)
China	2.17 " " (2.67)

The figures in brackets include an addition of 0.5 sq.m. for discussion space which is not included in any of the plans studied, but which is essential for comparison with the area desired above. In fact the absence of a discussion space would mean that a classroom would be required for this function and the real area (classroom plus laboratory) would be larger than is suggested here.

As far as the shape of the laboratory is concerned, there would appear to be no special requirements other than those imposed by the need to achieve effective illumination, with or without artificial light and the need for thermal comfort. Laboratories have been designed as circles, as regular polygons and as trapezoids. Plan shapes other than rectangular usually require the building to be free-standing and this leads to greater expense. As one of the purposes of this paper is to suggest economical laboratories, the solutions given are all rectangular and the spans and column spacings indicated are those already commonly in use in the Region. This will permit the laboratory to fit into any part of a normal building.

ii) Space in the store - for apparatus for teaching group of 40.

The appendices list the sort of equipment that would probably be found in a well-equipped physics laboratory.

With some items stored in the laboratory (on the basis of common use) experience shows that the separate store area needed would be about 28 sq.m. or 0.70 sq.m. per place. This area compares most favourably with that actually provided by a number of countries whose standard plans have been mentioned above, where the provision of storage space ranges from 0.44 to 1.09 sq.m. per place. The variation in space from one country to another depends on the amount of equipment provided and it may be significant that those with the largest gross investment in education have the largest stores.

iii) Space in the dark-room - for teaching groups of four students and a teacher -

Experimental work-bench	2.25 sq.m.
Printing and developing	4.50 " "
Storage and circulation (say)	1.50 " "
Total (say)	<u>8.25 " "</u>

this is a per place area of about 0.20 sq.m. per place. Regional comparisons are hardly valid in this case as only in two of the examples of standard plan studied was a dark-room provided.

iv) Space for preparation, for the teacher and for project work -

Experimental work-bench	2.25 sq.m.
Preparation bench	4.50 " "
Teacher's desk	3.35 " "
Storage and circulation	1.00 " "
Total (say)	<u>11.10 " "</u>

This is a per place area of 0.26 sq.m. It is difficult to compare it with other schools in the Region, as although provision may be made for these essential activities, there is no such indication in the plans studied.

The total area for a physics laboratory facility may thus be summarised as follows:-

The laboratory proper	2.40 sq.m.
The store	0.70 " "
The dark-room	0.20 " "
Preparation, project and teacher	0.25 " "
Total (say)	<u>3.55 " "</u>

This space provision, it should be emphasised, requires nothing more for the teaching of the physics syllabus in its entirety. No additional classroom is needed.

The study also clearly shows (as will be seen from the plans that follow) that the smaller the teaching group the greater per place area needed; 4.5 sq.m. per place for a group of 20 and 3.4 to 3.8 for 40.

Some suggestions as to ways in which these areas can be arranged for convenient teaching are given in the following pages. Four types of laboratory plan are illustrated as follows:-

For the hot-humid zones (Figures 22 to 24 and 31 to 33)	a laboratory for 40 students.
	a laboratory for 20 students.
For the hot-dry or cold zones (Figures 25 to 30)	a laboratory for 40 students.
	a laboratory for 20 students.

Each plan is shown with fixed furniture only and in the adjoining drawings are indicated four possible ways of arranging movable furniture in it depending on the nature of activity desired. Thus there is a furniture arrangement for the laboratory used for discussion, an arrangement for general experimental work, another for use involving mains power and finally one for use of the floor for ripple tank work. As two dimensional drawings are sometimes difficult to read, each plan is accompanied by a perspective outline showing the laboratory with all its furniture except the chairs which have been omitted as in such small-scale drawings, they tend to confuse.

Also accompanying each plan is a description of the facility explaining the layout in terms of climate, illumination and the arrangement of furniture. An analysis of areas is also provided.

The following key is used throughout the drawings:-

B	- Free-standing students' work-table (as in plate 1)
C	- Chart cabinet (as in figure 20)
Ch	- Chalkboard.
H	- Hatch from store to laboratory (as in figure 16)
L	- Book and periodical shelves (as in figure 19)
P	- Project work-table (as in figure 17)
R	- Ripple tank
S	- Students' book and bag storage unit (as in figure 18)
St	- Storage cupboards
T	- Teacher's demonstration table (as in figure 19)
WB	- Wall fixed bench with or without cupboard over and under (as in figure 14 and 15)



40 - PLACE LABORATORY

*see Fig. 22 opposite*

The figure shows the laboratory, preparation room, dark room and store with fixed furniture. Figure 23 overleaf indicates alternative arrangements of furniture for this laboratory which is suitable for use in hot-humid climates.

The windows on either side of the main space will permit of good cross ventilation *provided the building is oriented to face the prevailing breeze*. The dark room should, where electricity is available be ventilated by a light-proof extract fan on the external wall drawing air through the preparation, projects and teacher's room. A fan of about 40cm diameter will be adequate for this purpose. Where electricity is not available then light-proof ventilation blocks could be built in the walls of the dark room or openable windows provided with shutters that may be closed only when darkness is essential.

The width of the laboratory, 8.0m., is the maximum possible if reasonable illumination is to be obtained without supplementary artificial lighting. Higher illumination levels will be obtained nearer the windows which should rise from the level of the top of the backboard of the benches (Figure 14) to the ceiling which need be no higher than 2.7m above finished floor level. Windows should, of course, be shaded to prevent direct sunlight from entering the laboratory for the whole of the school day.

Key:

- B - Free standing students' work-table
- C - Chart cabinet
- Ch - Chalkboard
- H - Hatch from store to laboratory
- L - Book and periodical shelves
- P - Project work-table
- S - Students book and bag storage unit
- St - Storage cupboards
- T - Teachers' demonstration table
- WB - Wall-fixed bench.

AREA PER PLACE :-

Laboratory.....	2.4.sq.m.
Ancillary spaces.....	1.4.sq.m.
Total area per place...	<u>3.8.sq.m.</u>

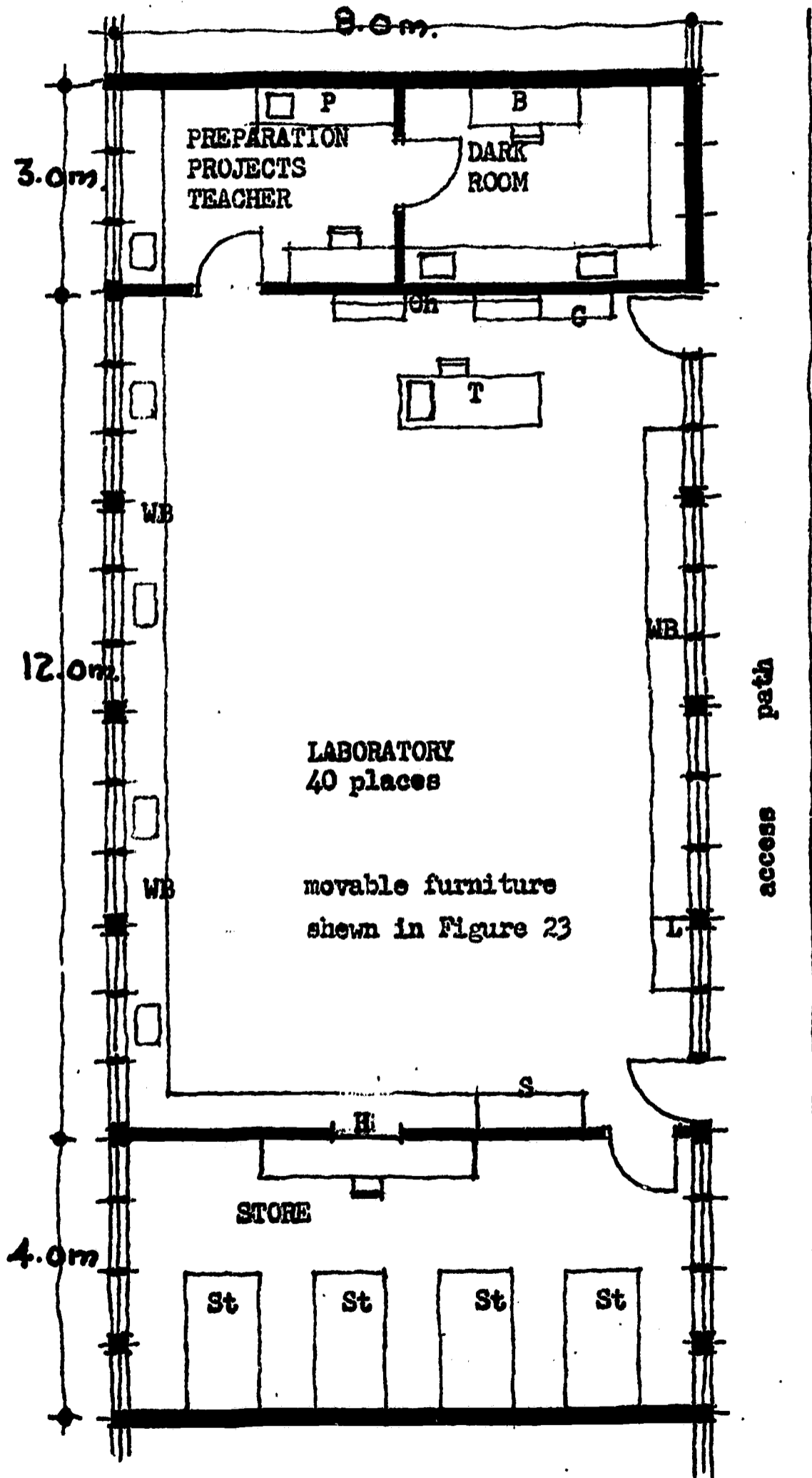

FIGURE 22

LABORATORY FURNITURE ARRANGEMENTS

showing how furniture can be moved as the subject matter and teaching methods change

(see Figure 23 opposite and Figure 24 overleaf)

Arranged for General Experiments

For experiments not requiring power, water or gas (Table III) the movable work-tables (Plates 1 and 2) are arranged in the body of the room and away from the wall benches.

The space in the middle of the room is available for experiments not requiring a bench.

Arranged for Discussion

The students' chairs (Fig.2) are gathered from the movable work-tables and arranged formally or informally near the teacher's demonstration table (Figure 21). This involves pushing four benches to one side.

*Key:*

- B = Free-standing students' work-table
- R = Ripple Tank

Arranged for Ripple Tank

Ripple tanks need to rest on a vibration free surface. The best surface of this nature is the floor of the laboratory or, where a lamp is required under the tank, on a rigid stand. It is also necessary to place the tanks (of which 10 are shown) in a good light and out of the shadow of the wall bench. A 75cm circulation gangway is left for the teacher between the wall benches and the tanks.

Arranged for Use of A.C. Power

Power outlets are arranged in the backboards of the fixed wall benches (see figure 14 and 15). In order conveniently to use these outlets, the students' movable work-tables (Plate 1) are arranged along the wall benches thus avoiding wires trailing across the floor. 1.0m is sufficient space between the movable benches.

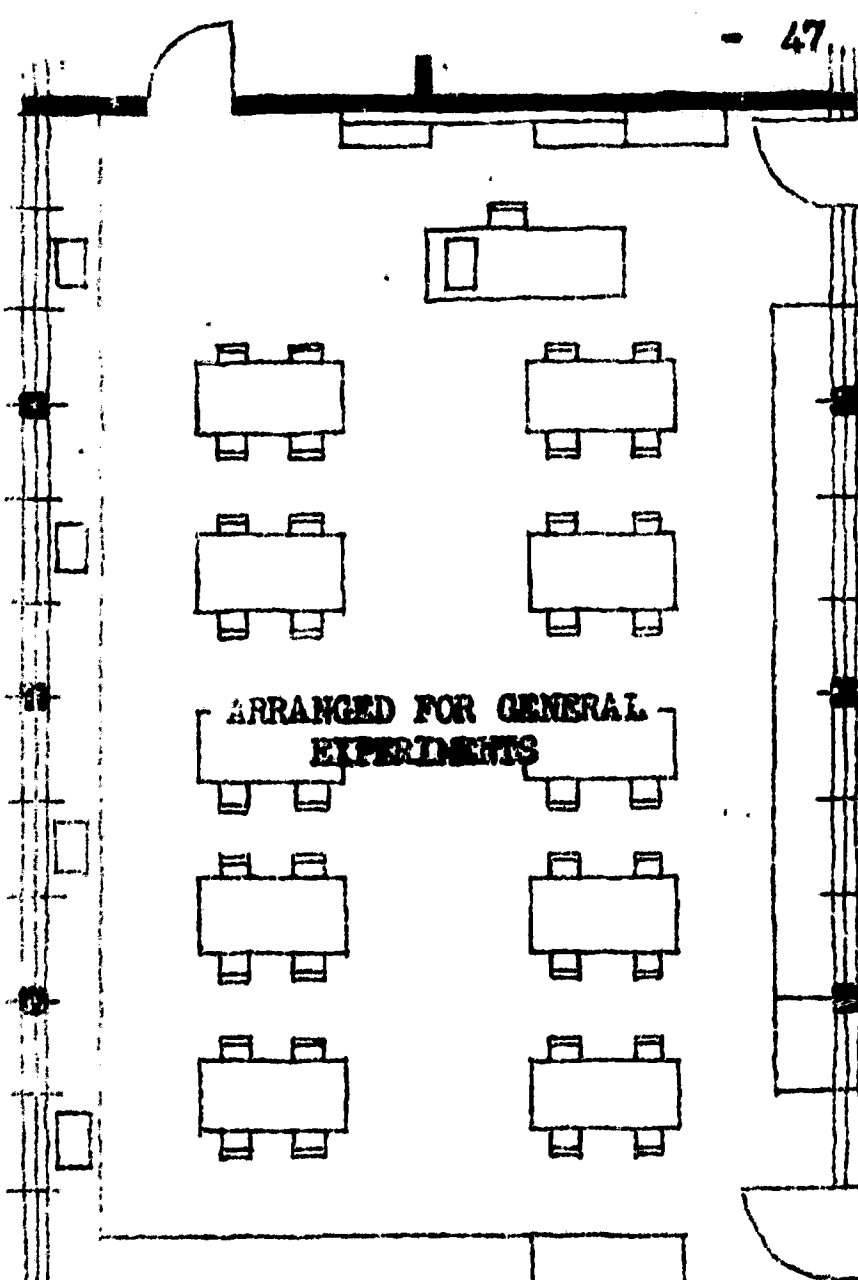

ARRANGED FOR GENERAL EXPERIMENTS

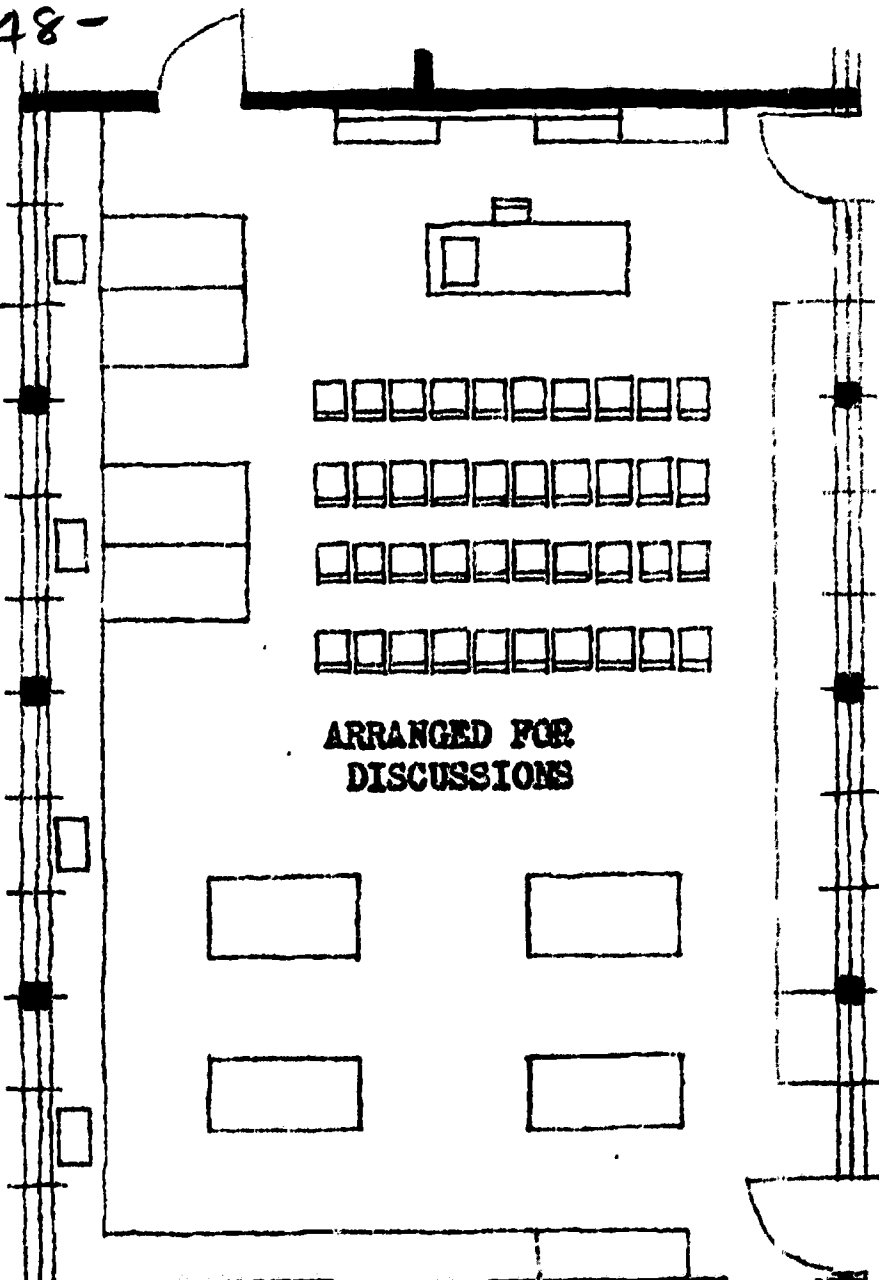

ARRANGED FOR DISCUSSIONS

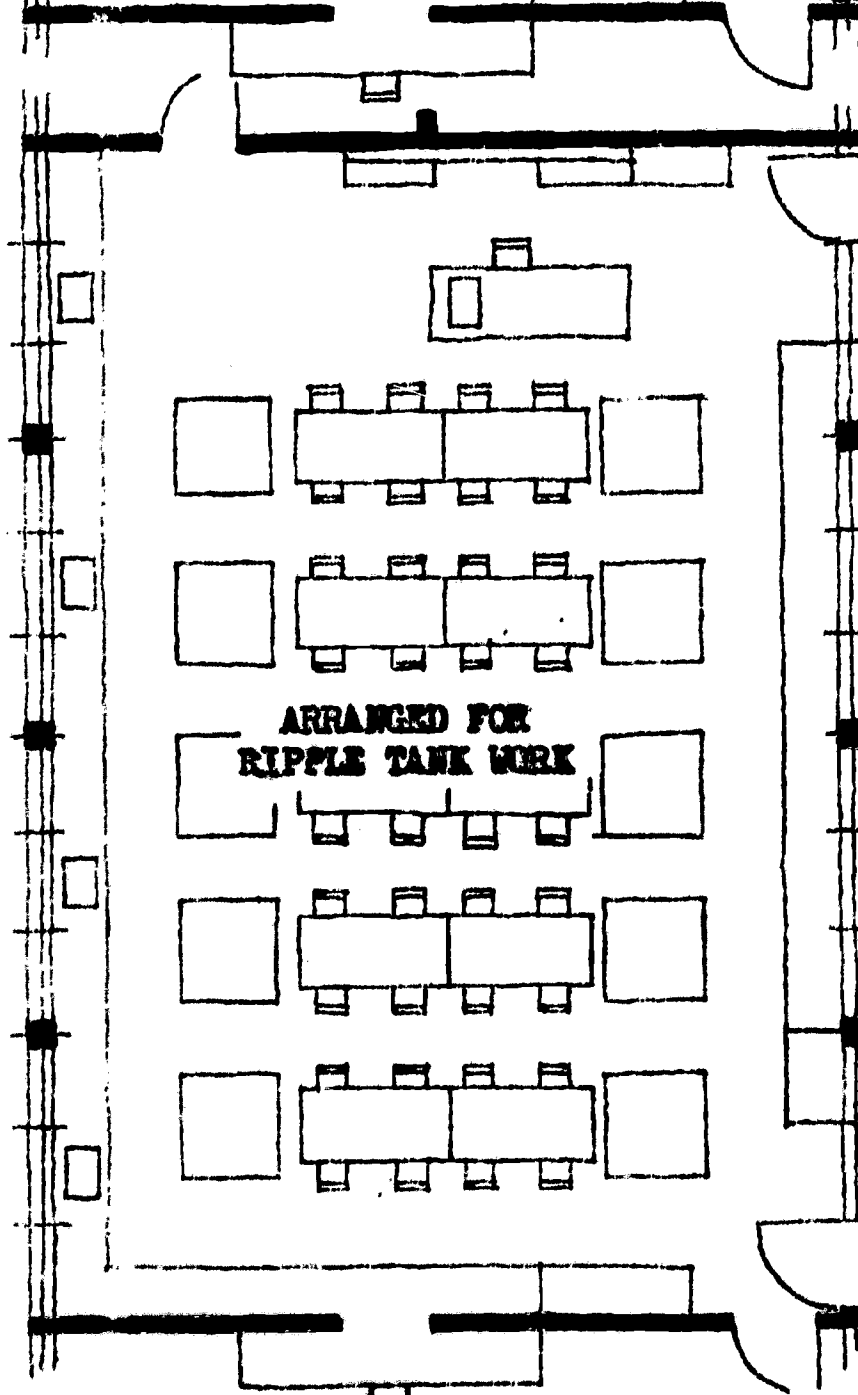

ARRANGED FOR RIPPLE TANK WORK

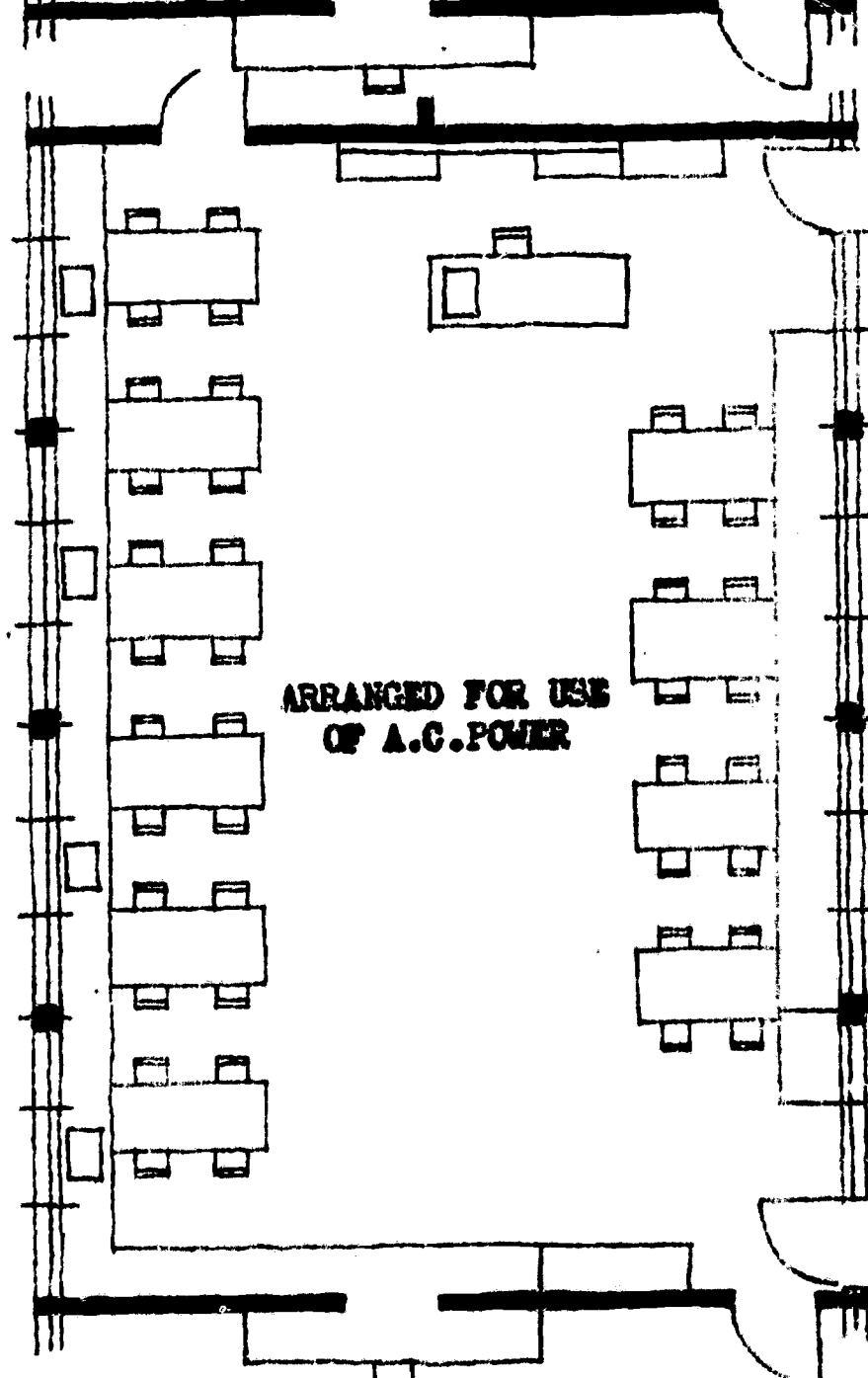

ARRANGED FOR USE OF A.C. POWER

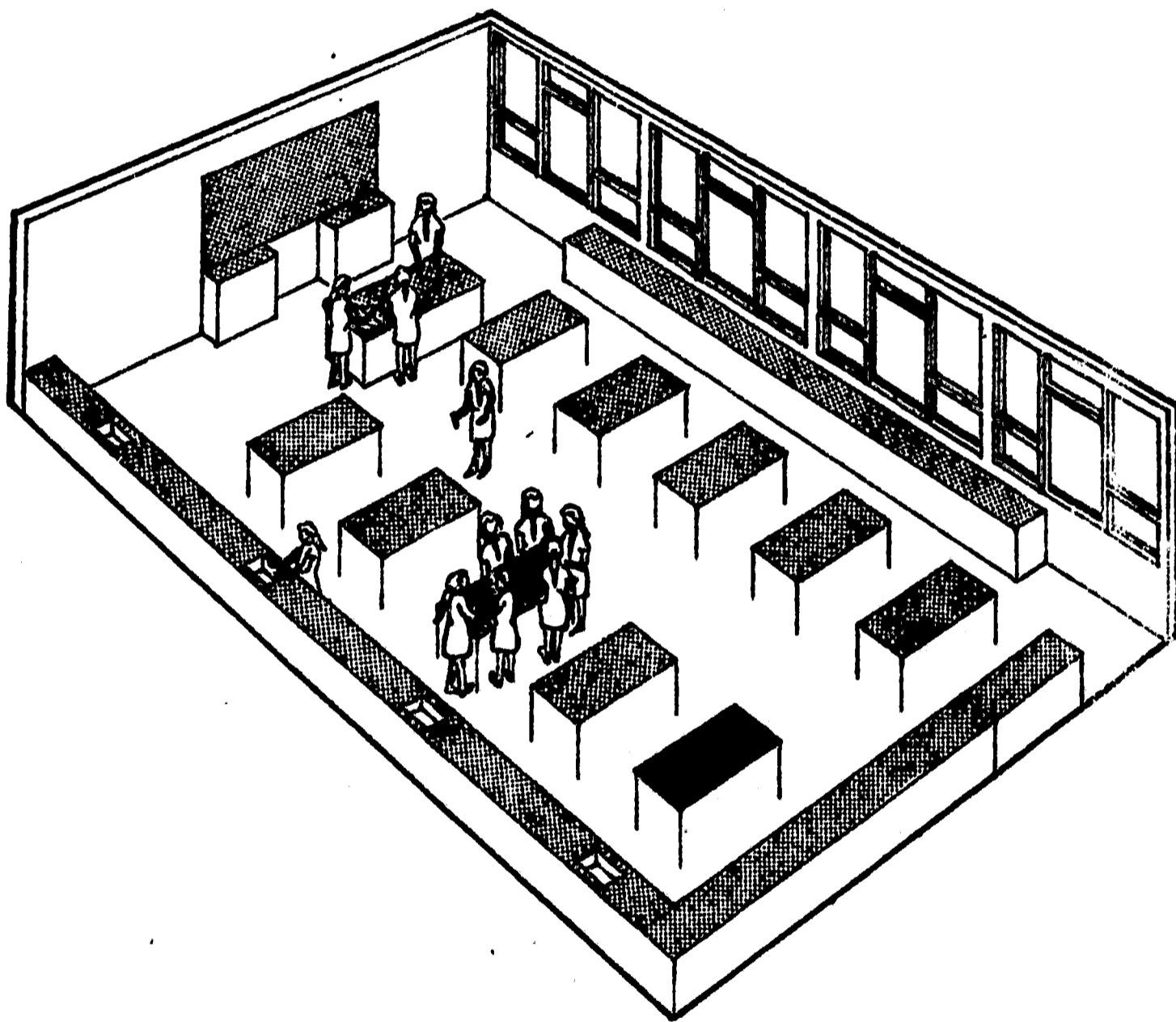

View of 40-place laboratory lit from both sides and arranged for general experiments (see Figures 22 & 23).

Figure 24

40 -- PLACE LABORATORY

*(see Figure 25 opposite)*

This laboratory, lit from one side only, is suitable for hot-dry or for colder climates where cross ventilation is not only unnecessary for even undesirable. The laboratory will probably be entered from a main corridor on the other side of which will be other teaching spaces.

Due to the fact that light is available on one side of the laboratory only, the width of the unit has been reduced to 7.0m so that it will be suitable for use in situations where electric lights may not be available. Even with this reduced span, the illumination level near to the corridor wall will be very low and this wall is therefore used for storage cabinets. All experimental work should be arranged as close to the window wall as possible to obtain maximum illumination from windows which should, however, be shaded from direct sunlight in hot-dry areas.

AREA PER PLACE:

Laboratory	2.2.sq.m.
Ancillary spaces	1.2.sq.m.
Total area per place	<u>3.4.sq.m.</u>

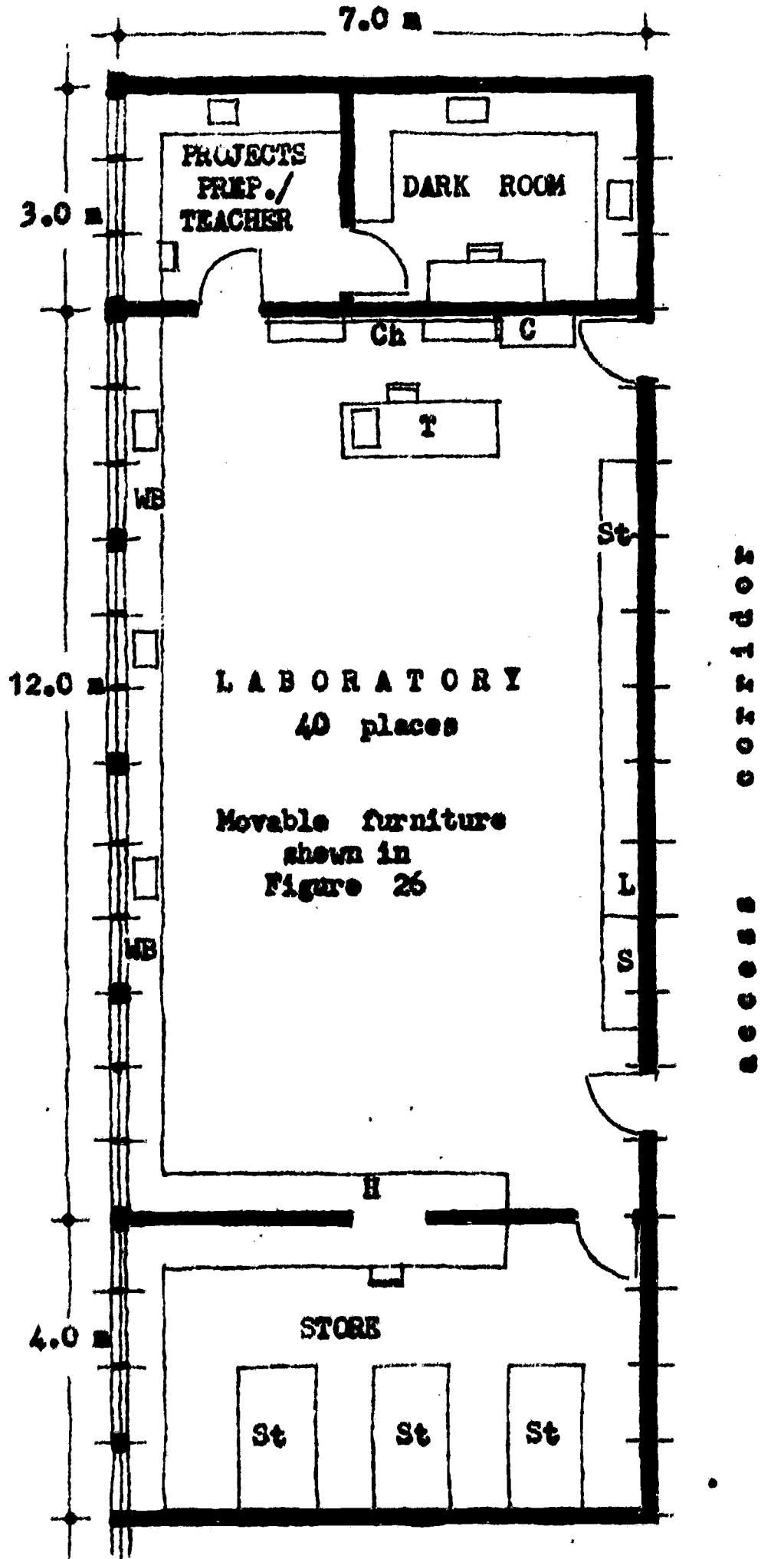

FIGURE 25

**LABORATORY FURNITURE ARRANGEMENTS**

showing how furniture can be moved as the topic  
and teaching methods change

(see Figure 26 opposite and Figure 27 overleaf)

Arranged for General  
Experiments

Students' movable work-tables have been arranged as close to the window as possible, avoiding the under-illuminated area near the corridor wall. The tables are arranged so that no student sits with his back to the light.

Arranged for Discussion

Tables have been pushed into the side and back of the laboratory so that chairs may be grouped formally or informally near the teacher's demonstration bench and chalk board which, if the room is decorated with light reflecting colours, should receive enough natural light.

Arranged for Ripple Tank  
Work

Illumination in the centre of the room will be adequate for ripple tank work. To make room for the tanks, the movable tables have been pushed back to the walls and a central passage left for the teacher.

Arranged for Use of A.C.  
Power

Five of the movable tables have been pushed to the wall bench in which power outlets are located. The remaining tables will receive power from two floor sockets.



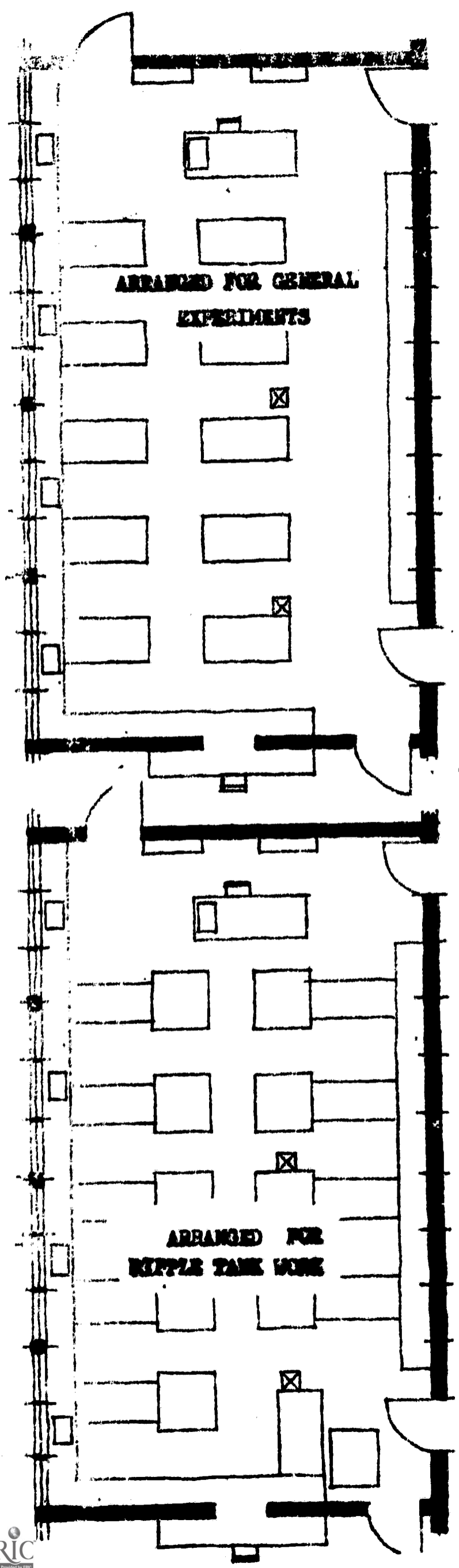

ARRANGED FOR GENERAL  
EXPERIMENTS

ARRANGED FOR  
RIPPLE TANK WORK

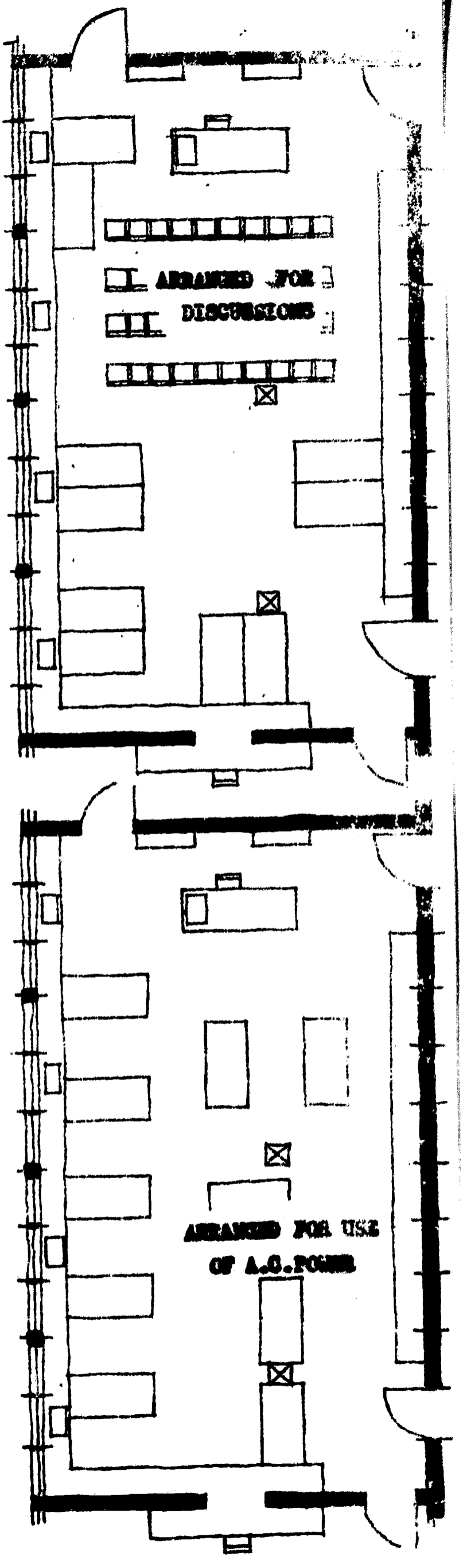

ARRANGED FOR  
DISCUSSIONS

ARRANGED FOR USE  
OF A.C. POWER

FIGURE 26

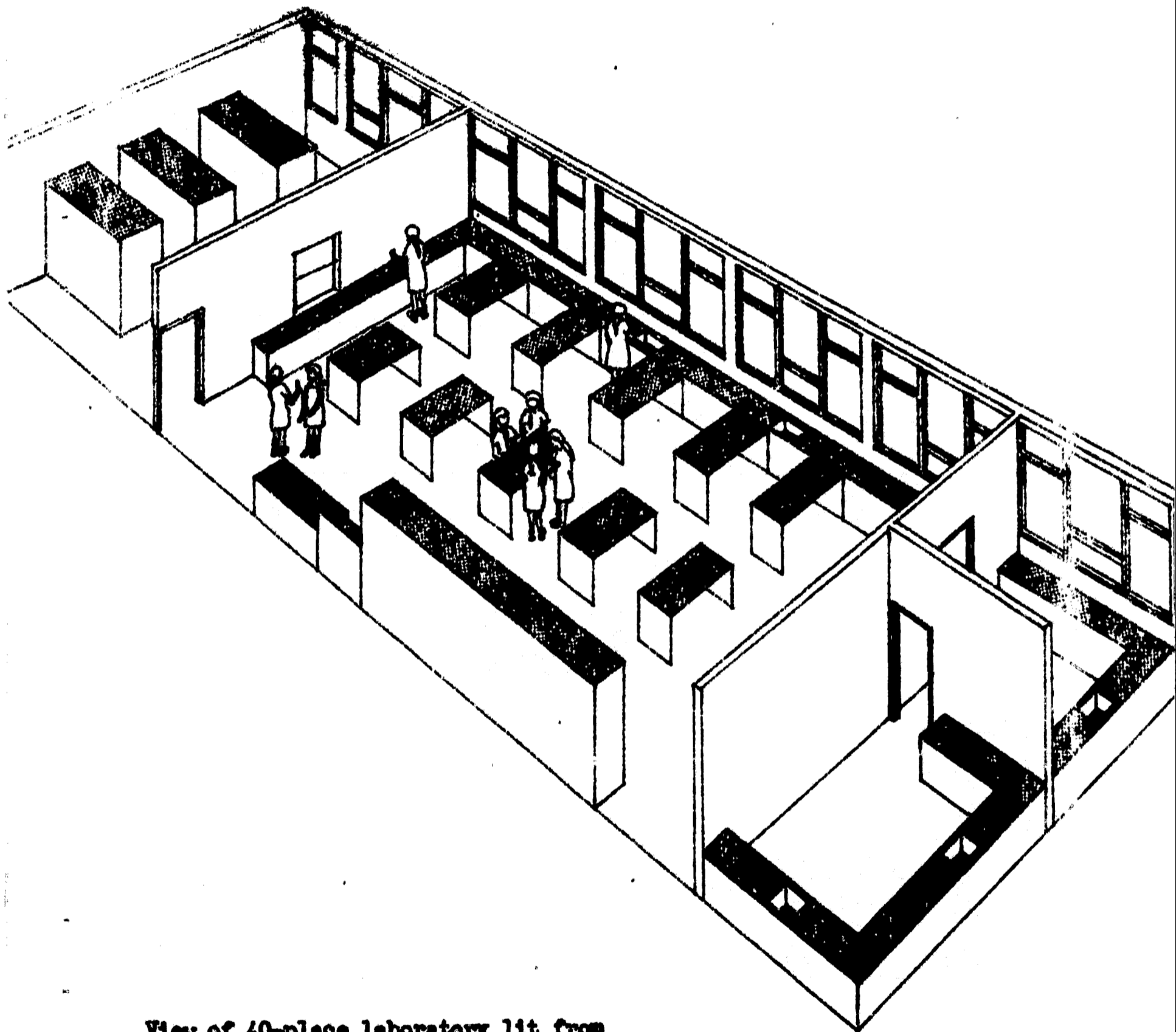

View of 40-place laboratory lit from one side and arranged for general experiments (see Figures 25 & 26)

Figure 27

20 - PLACE LABORATORY

(see Figure 26 opposite)

The two 40-place laboratories shown in Figures 22 and 25 have total areas per place of 3.8 and 3.4 sq.m. respectively. This smaller laboratory requires 4.5 sq.m. per place and illustrates the rule that the smaller the size of a teaching group, the more expensive it is to accommodate it.

The laboratory is similar in character to that illustrated in Figure 25 and is suitable for use in hot-dry or cold climates. It has only one external wall which, in the absence of supplementary artificial lighting, forms the main source of illumination.

The equipment required for 20 students does not justify the provision of a separate store in what is already a very expensive facility. Storage cupboards have thus been arranged along the corridor wall and "over" and "under" storage cupboards would be provided on the cross wall facing the demonstration table.

**AREA PER PLACE:**

Laboratory	3.5 sq.m.
Ancillary spaces	1.0 sq.m.
Total area per place	<u>4.5 sq.m.</u>

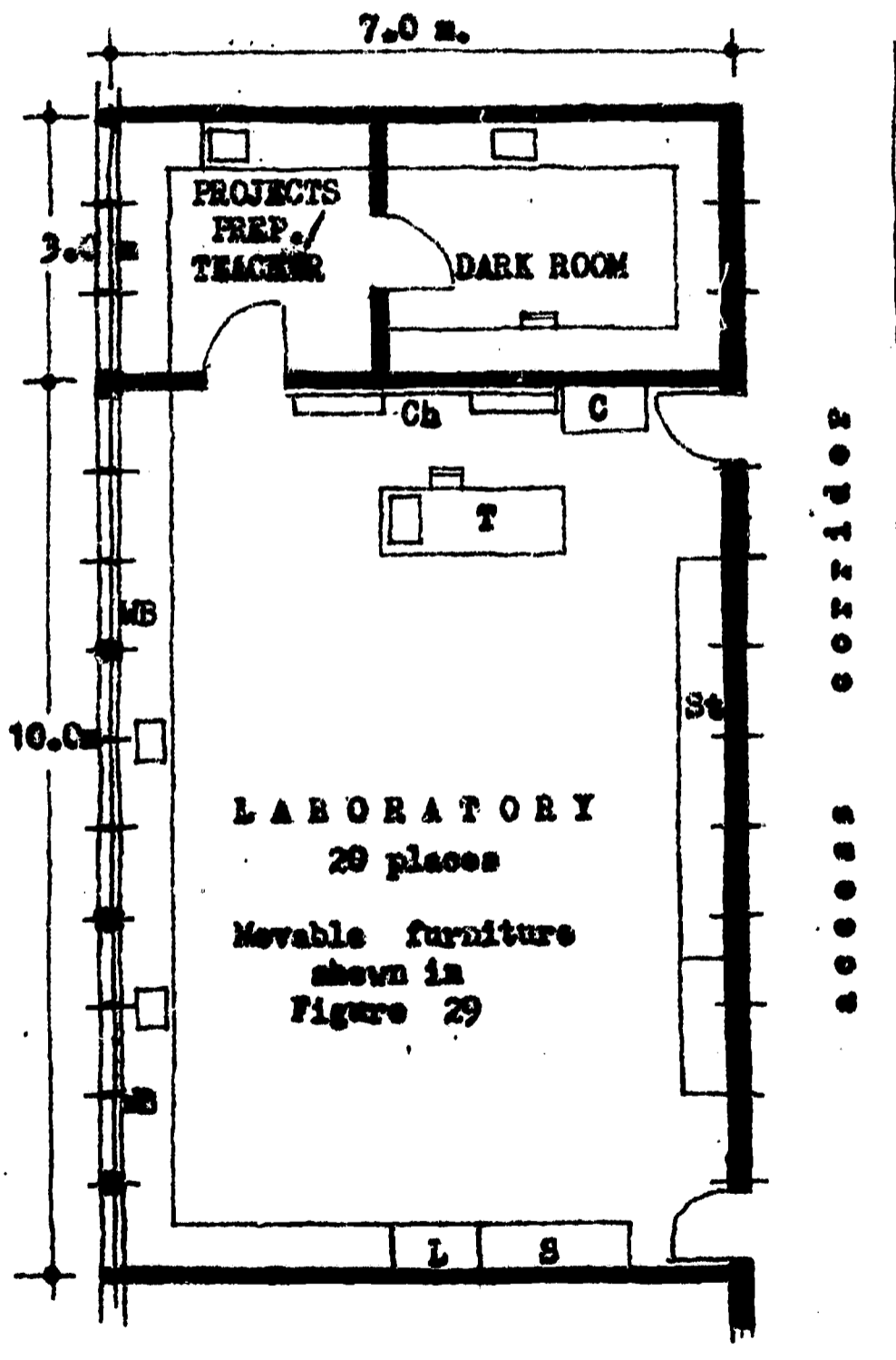

**FIGURE 28**

LABORATORY FURNITURE ARRANGEMENTS

*showing how furniture can be moved as the subject matter and teaching methods change*

*(see Figure 29 opposite and Figure 30 overleaf)*

Arrange for General Experiments

The illumination is greater nearer the window wall and least at the corridor wall. Tables, are therefore, placed as close to the windows as possible, leaving a free space for movement round each table. The students at the single bench away from the window might, for some experiments, be located at the fixed window bench.

Arranged for Discussion

Movable tables are pushed back and student chairs grouped formally or informally around the demonstration bench

Arranged for Ripple Tank Work

Good light on the tanks, which are located on the floor, requires that they be placed near to the window but out of the floor shadow cast by the wall bench. Circulation space for the teacher is also important.

Arranged for use of A.C. Power

All A.C. outlets are located in the fixed bench at the window. The movable tables are, in this case, pushed across to the fixed bench to facilitate electrical connections without trailing wire.

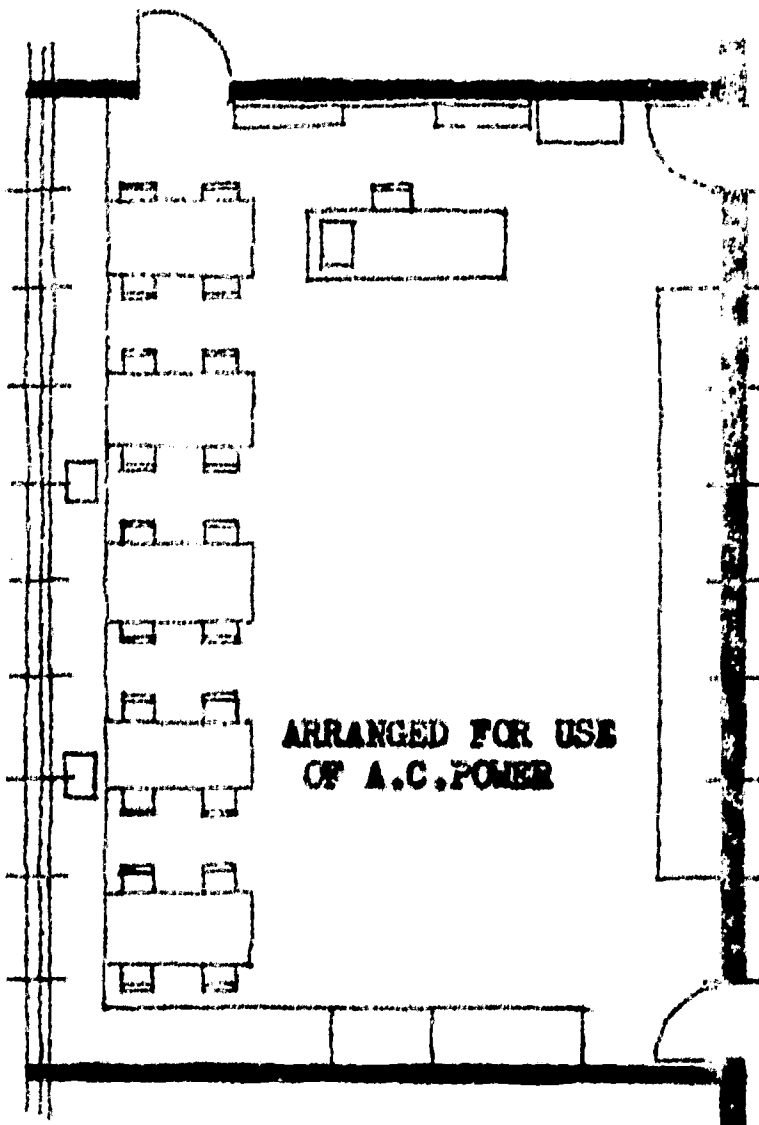
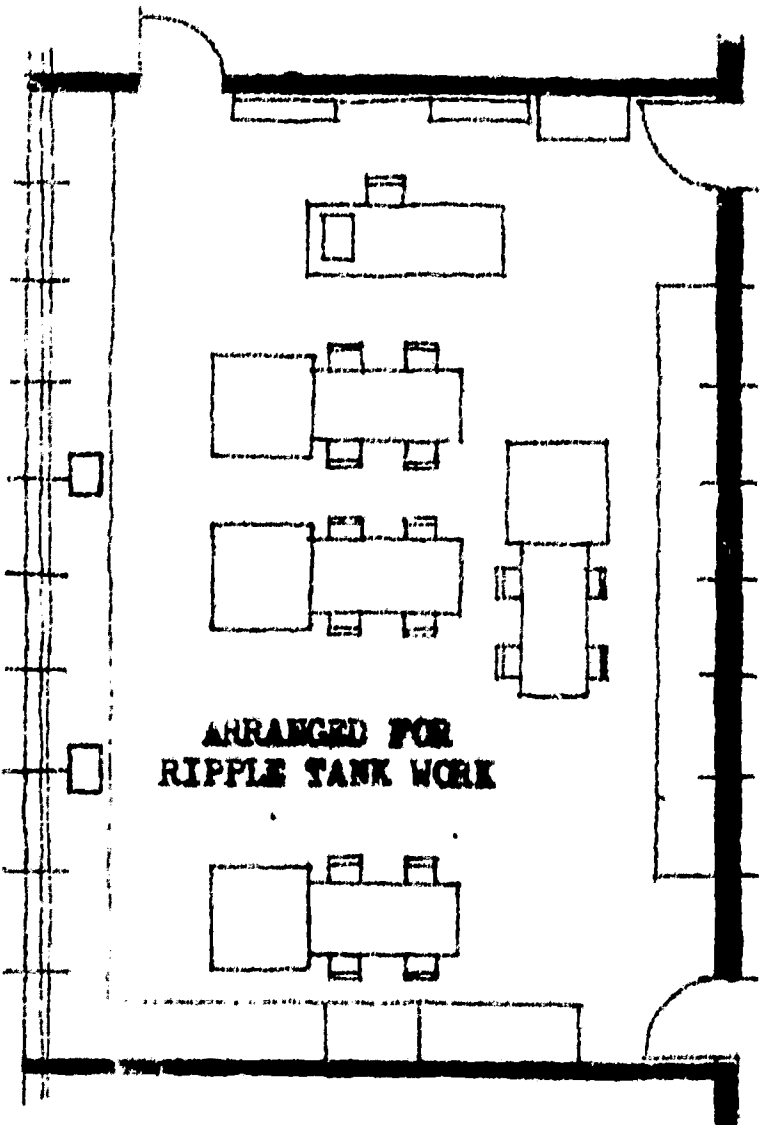
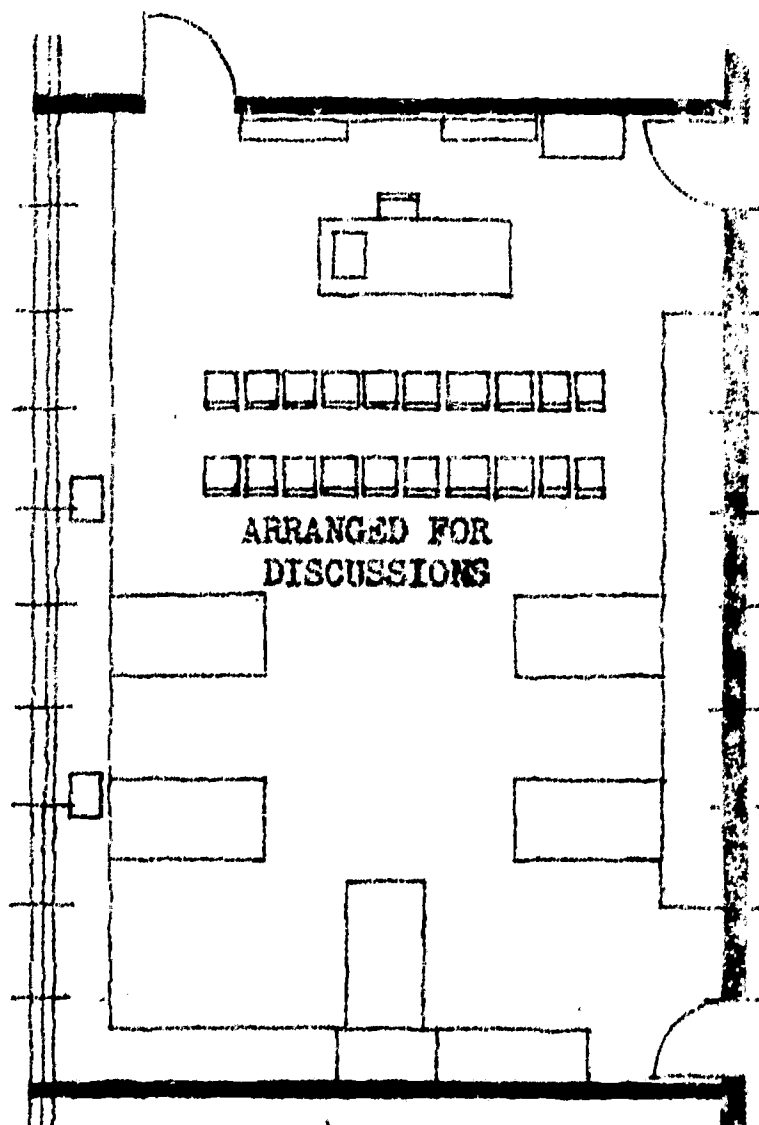
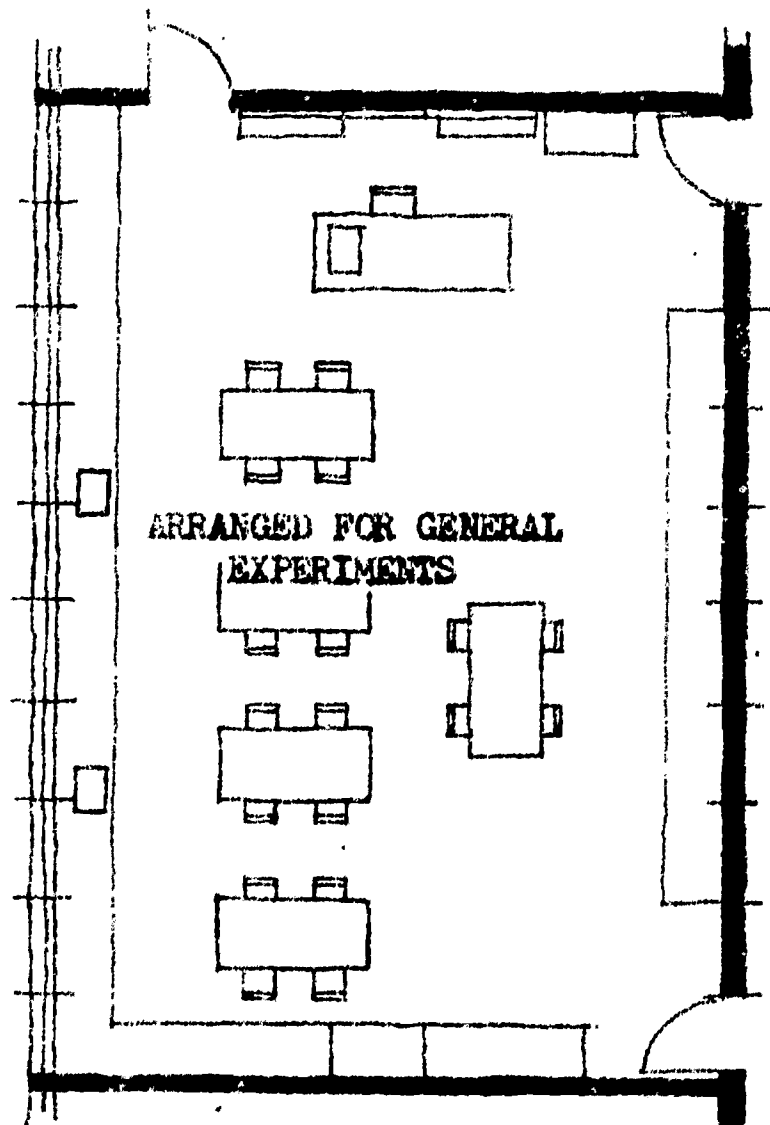
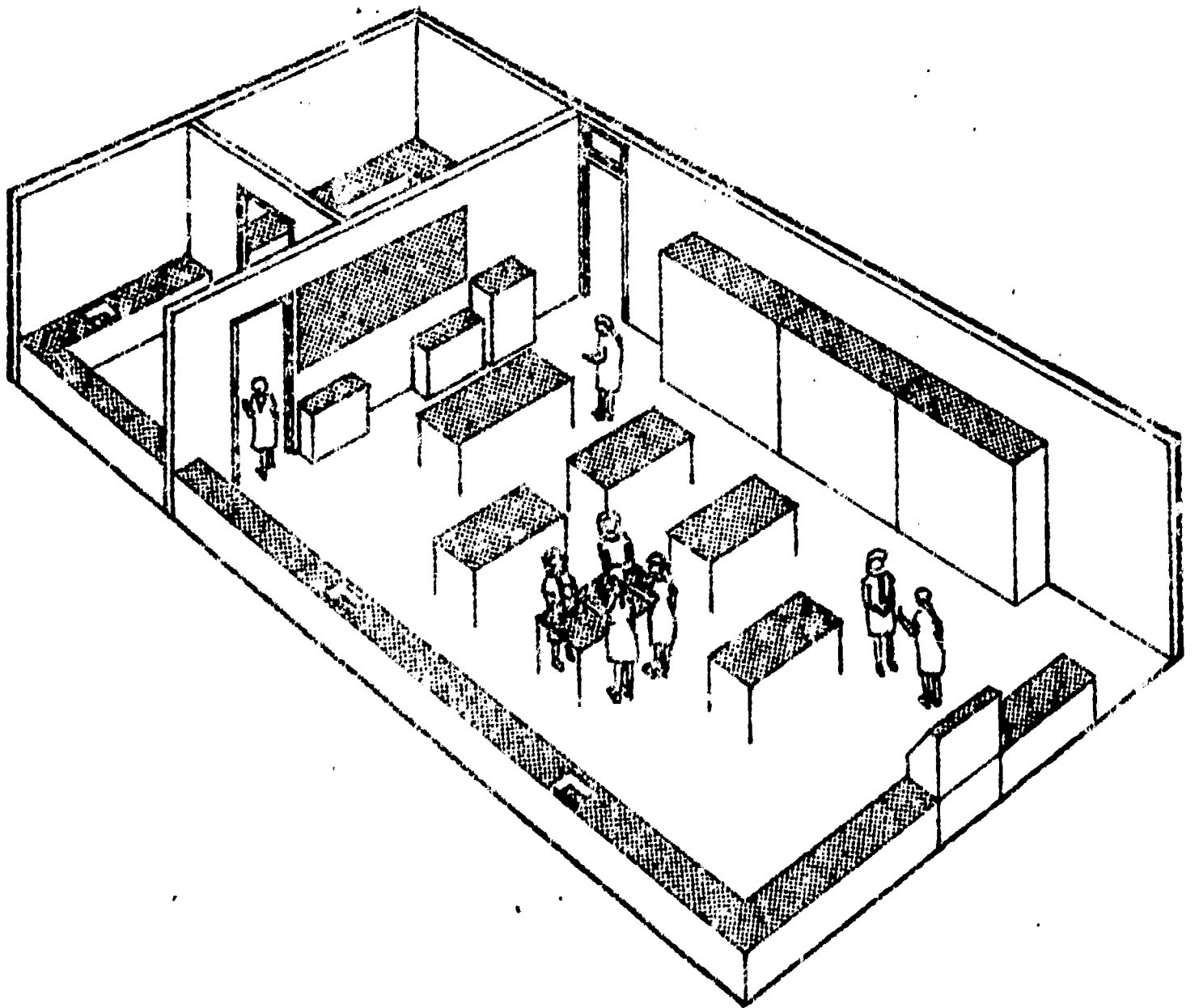

Figure 29



View of 20-place laboratory lit from one side and arranged for general experiments (see Figures 28 & 29)

Figure 30

20 PLACE LABORATORY

(see Figure 31 opposite)

This smaller laboratory has the same area as that in Figure 28, i.e. 4.5 sq.m. per place. It is thus more expensive per place than a laboratory for 40 students.

The advantage of this laboratory is however, that it is lit from both long side walls with a resulting improved distribution of illumination. As it can be cross-ventilated it is particularly suited for use in hot-humid climates, but if the windows were sealed and the external walls shaded it would also be fairly comfortable in hot, dry climates.

As in the laboratory shown in Figure 28, a separate store has been omitted. This might create difficulties in a very well-equipped school as there will be no above-bench storage along the window walls. In these circumstances, it might be necessary to substitute storage cupboards for the work-bench along the short wall at the opposite end of the laboratory from the chalkboard.



AREA PER PLACE:

Laboratory	3.5.sq.m
Ancillary spaces	<u>1.0.sq.m</u>
Total area per place	<u>4.5.sq.m</u>

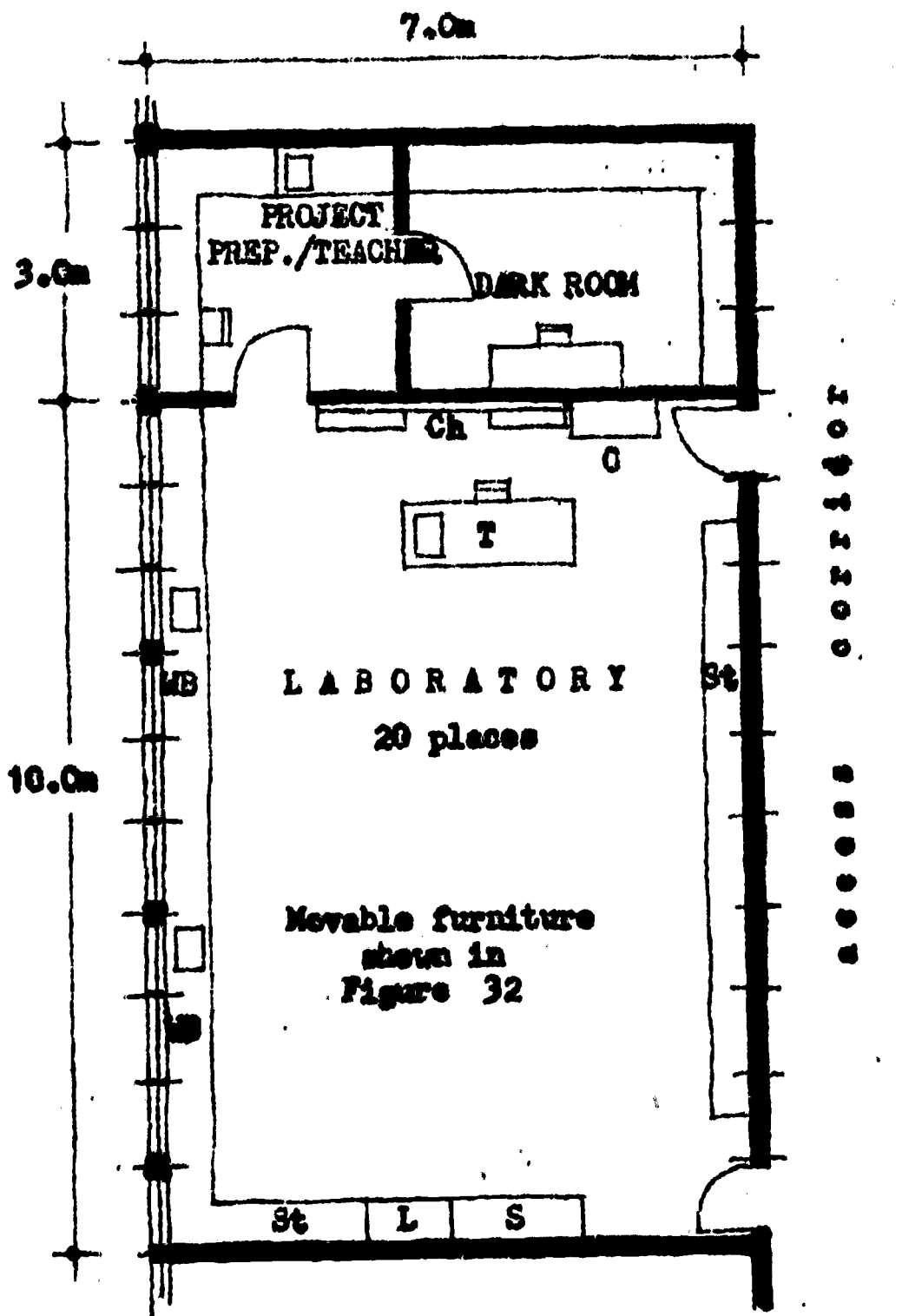

FIGURE 31

LABORATORY FURNITURE ARRANGEMENTS

*showing how furniture can be moved as the subject matter and teaching methods change  
(see Figure 32 & Figure 33 overleaf)*

Arranged for general experiments

The illumination, although highest nearer the windows, is above the minimum required at all points in the laboratory. The movable tables can therefore be located in the central portion of the laboratory. They should be arranged so that light falls along the table and so that no student works in his own shadow.

Arranged for discussion

For discussion the movable tables are pushed back a little and the student chairs grouped formally or informally around the demonstration bench.

Arranged for ripple tank work

With good light coming from both window walls, the ripple tank can be placed alternately on either side of the centrally arranged tables, leaving adequate passages for movement of both teacher and students.

Arranged for use of A.C. power

Power is available at benches on the long, window walls and to avoid trailing wires, the movable tables are pulled across to join the wall benches.

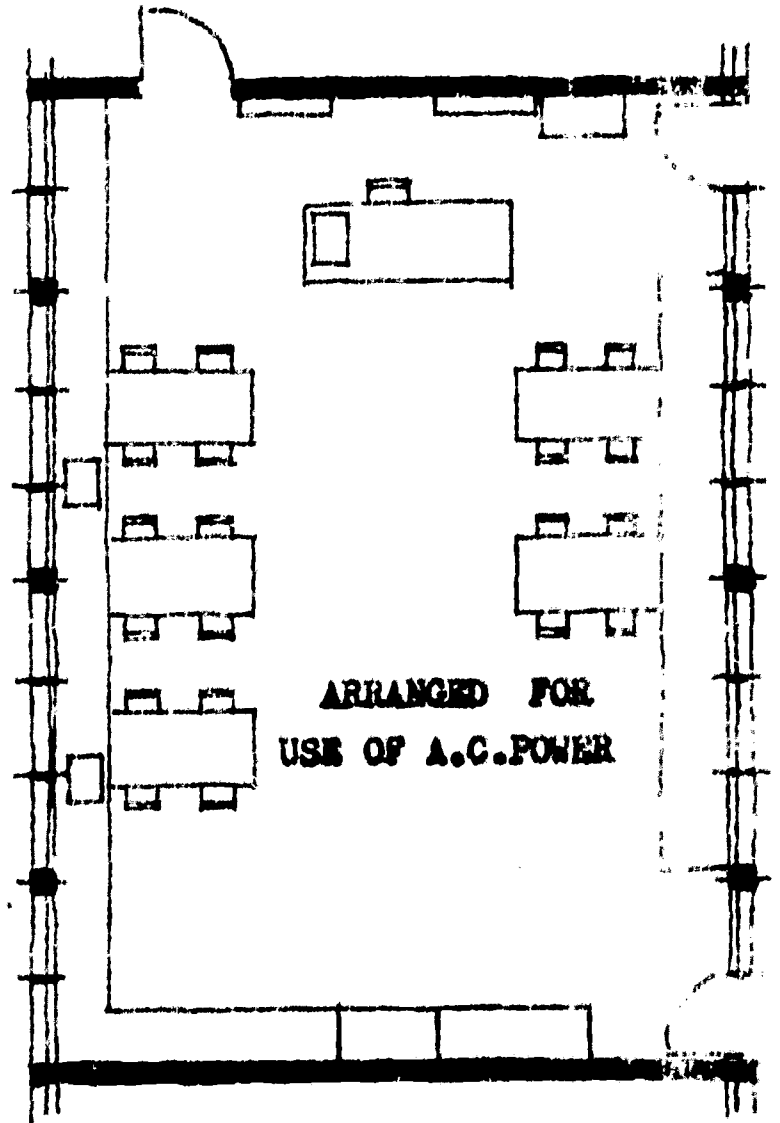
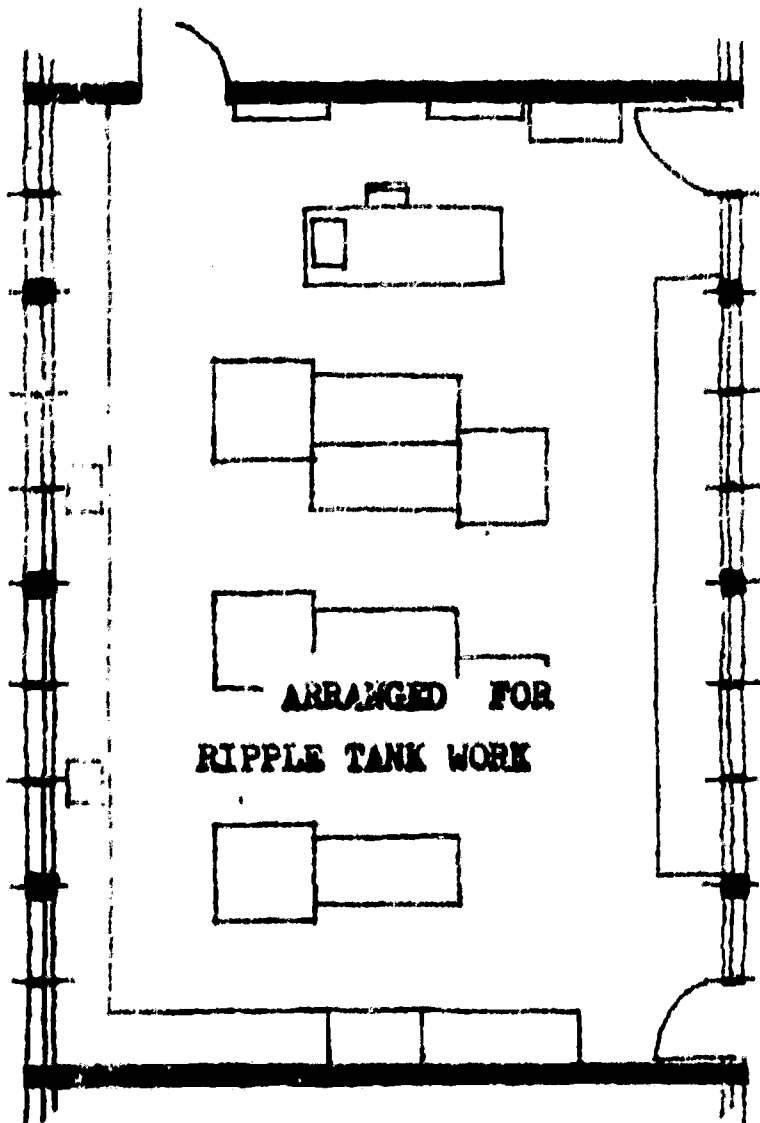
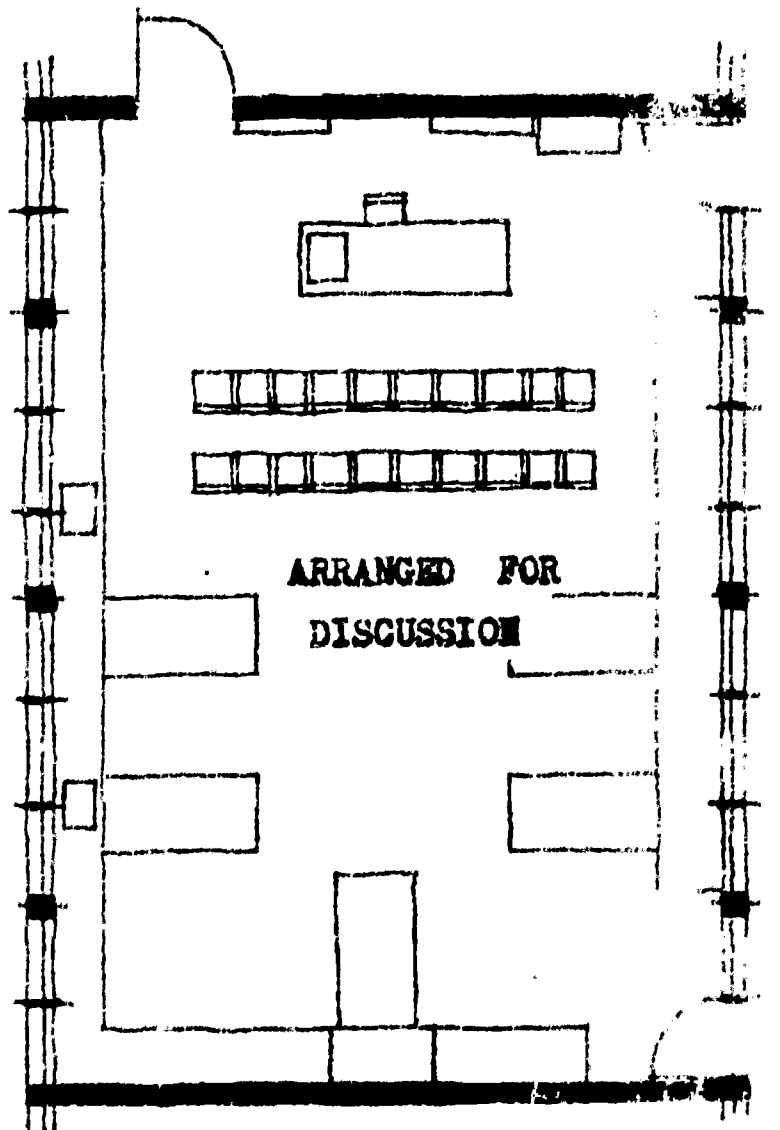
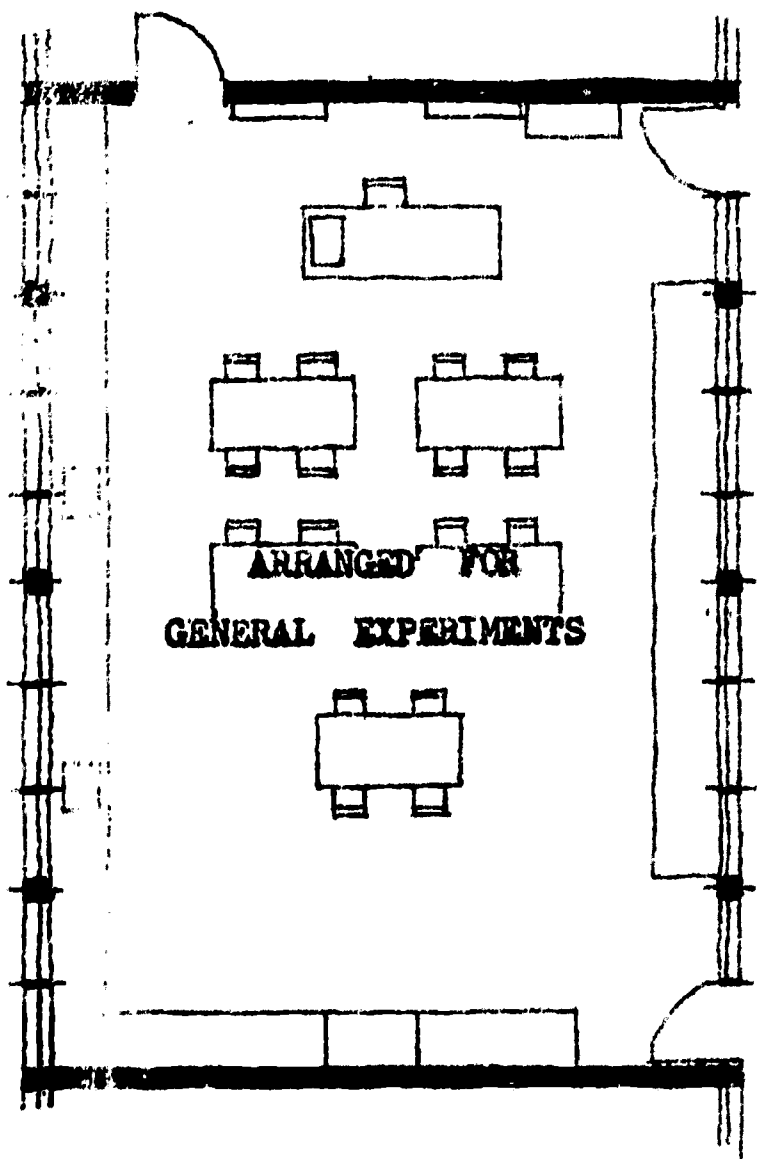
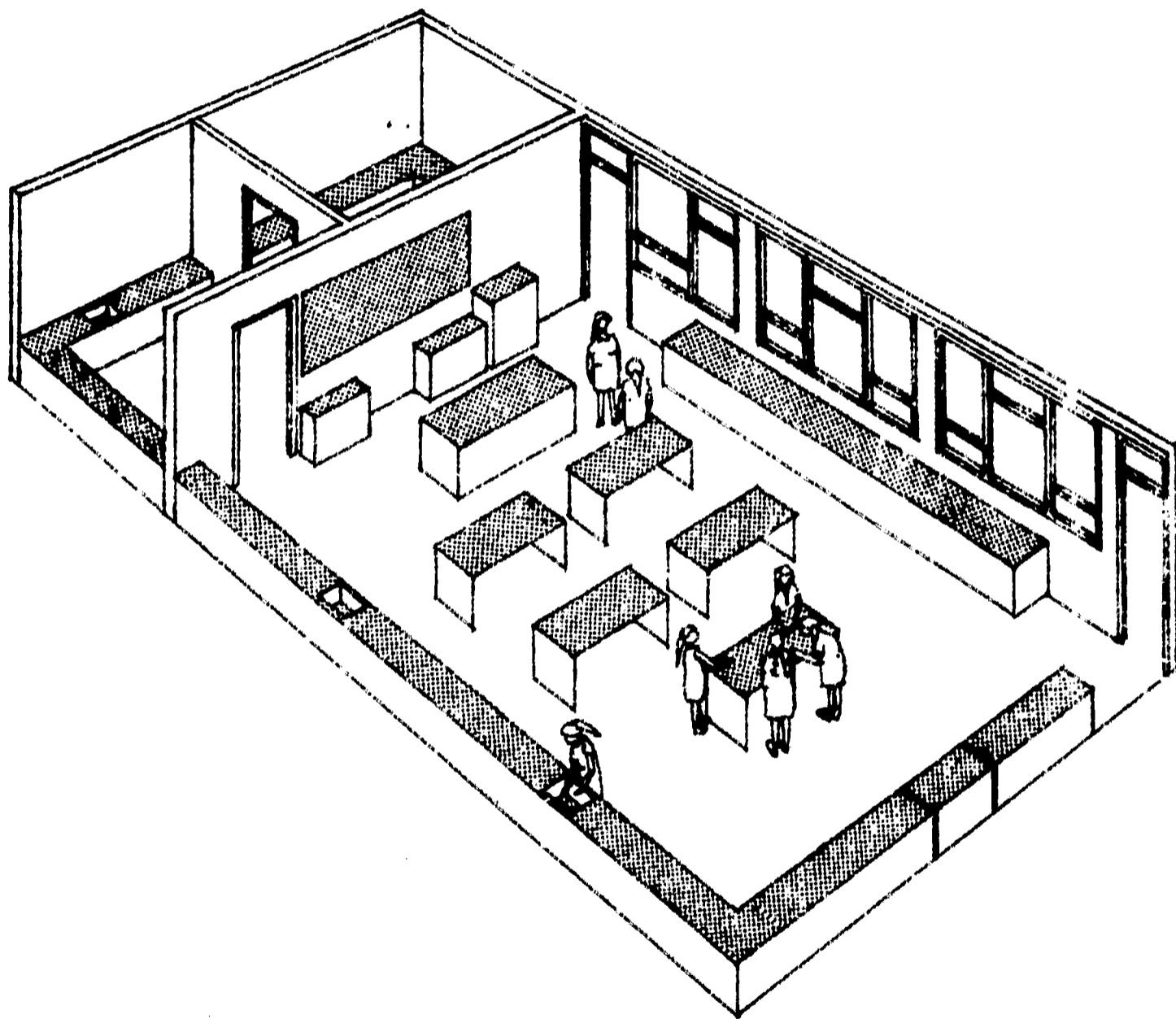

FIGURE 3



View of 20-place laboratory, lit from both sides and arranged for general experiments (see Figures 31 & 32)

Figure 33

## CHAPTER 5

### THE PHYSICS LABORATORY STORE

#### 5.01 General

The problem of storage of physics teaching equipment is sufficiently complex to warrant a separate chapter in this study. It is significant that in every physics facility studied in the Asian Region, whilst very few make provision for a teacher's room, project room and dark room, all include a store for physics apparatus. The average area of these stores is about 12% of the area of the laboratory although in some cases it is substantially more rising in one or two countries to a quarter of the laboratory area.

The reasons for this will be clear from a study of the appendices to this paper in which are listed the items of equipment normally found in a very well-supplied school and those in a school working with a minimum amount of equipment. The list for a well-supplied school totals some two thousand items. An adequately but less well-supplied group of schools in the Region had some 224 items to be stored.

One of the points to be noted in the design of storage space for a laboratory is that new equipment and apparatus is always being added either by increasing the number of items issued from official sources or by the improvisation and construction of equipment by the teacher and students. Thus, in a country presently issuing 224 items of equipment for physics teaching, it may be assumed that as time passes and the amount of money invested in education slowly increases, equipment and apparatus will also be supplied in greater quantity. Space should be provided in all new buildings against this eventuality.

#### 5.02 The nature of the items to be stored

Most teachers prefer to store apparatus grouped for convenience as follows:-

- a) Commonly used items near to the tables in the laboratory or, if kept in the store, near to the issuing hatch (Figure 16) or the door to the store where a hatch is not provided. This saves labour and time. Commonly used items would include metre scales, connection wires, tools, retort stands, pins, needles, rubber tubing and the like. Most of these items can usefully be stored in drawers and thus the bench on the store side of the issuing hatch should be fitted with at least two drawer-units of the type shown in figures 15 and 16.

b) Cupboards, drawers and shelves under subject headings such as mechanics, heat, light, wave motion and electricity.

c) Shelves of essential chemicals.

In keeping the items listed in (b) above, it will be found that they present several storage problems. First, they will fall, by size, into two groups, some items such as lenses, being sufficiently small to keep in drawers and others such as aspirators, balances, beakers and the like requiring shelves or cupboards. Secondly and in particular in the humid tropics where humidity is always high, there will be items that need protection from corrosion, from etching (in the case of lenses) and from more general fungus and insect attack in the case of paper.

To some extent, cross-ventilation may retard fungus attack. Ventilation will, on the other hand, provide a good supply of moist air which could increase rather than decrease the corrosion rate.

The problem can be solved somewhat by keeping lenses and other optical glassware in dessicators stored on open shelves, by keeping corrosion-prone apparatus in cupboards fitted with 40 watt lamps - the heat from which will reduce the risk of condensation, and by keeping other items for which there is insufficient warmed cupboard space, in large glass bottles with greased, screw tops. Items such as paper and cloth pads can best be stored on open shelves in the draught provided by cross-ventilation.

From the foregoing it will be seen that storage fittings in the humid tropics will comprise a few warmed cupboards, two or three drawer-units and a great deal of open shelving. The same pattern can also usefully be followed in stores constructed in other climates. Whatever the climate, the storage facility is likely to be of less importance as a factor assisting in the maintenance of equipment than the constant care of the laboratory attendant. At best, a well designed store will make his work a little easier.

### 5.03 Furniture in the store

#### a) Open shelving

Equipment to be stored on open shelves would require the following areas:-

- 1) From Appendices I to VI inclusive, about 200 square feet of shelving.
- 2) From Appendix VII (the minimum list) about 50 square feet.

A variety of shelf widths and heights should be provided.

Some 15cm wide shelving with a height of about 15cm between shelves is useful for boxes of small items such as slides, corks and the like. 20cm shelves of the same height are useful for bottles of chemicals. 40cm shelves with a shelf height of 50cm will be suitable for balances, transformers and other similar larger items.

b) Drawer units

The drawer units shown in Figures 15 and 16 should be provided on a scale of six for a well stocked store and two for a store with minimum equipment. The work top over the drawer units will be useful for assembling sets of equipment prior to issue to the students.

c) Ordinary cupboards

Especially sensitive or particularly valuable equipment should be kept in locked cupboards. Two full-height cupboards would be needed for a well equipped laboratory and one for a laboratory having the minimum equipment.

d) Warmed cupboards

A warmed cupboard 1.80m wide and 60cms deep with double doors should be provided. The back and sides of the cupboards can be lined with 30cm wide shelves leaving a space in the centre in which the air warmed by two 40 watt lamps in the bottom of the cupboard can circulate.

e) Hanging boards

Certain items such as Fortin's barometer and Young's modulus apparatus can best be hung up on the wall of the store. A 1m square board with strong hooks will provide storage for such items.

APPENDIX 1

TOOLS FOR REPAIRING AND MAKING APPARATUS

Borers, cork	Level, carpenter's
Brace, with ratchet	Nail set
Brushes	Oil cans
Calipers, inside and outside	Oilstone
Chisels	Paint
Cold	Plane, black
Wood	Pliers
Drill, electric	Combination
Drill, hand	Longnose
Drill, press	Punch, center
Drills, set of carbon	Ruler, bench
Files	Saws, hand
Flat	Scissors
Round	Scraper, hand
Triangular	Screwdrivers; <i>select for size,</i>
Glass cutter	<i>type, length of shaft</i>
Grinder, bench type	Sharpener, cork borers
Hammers	Soldering tools;
Ball pein	Iron
Claw	Electric
Knives	Square, carpenter's
Electrician's	Toolboard, silhouette
Putty	Vise, 4" jaws
	Wrenches



APPARATUS FOR PHYSICS TEACHING

<u>Item</u>	<u>Physics</u>	<u>Item</u>	<u>Physics</u>
Acceleration board, Duffs	1	Barometer, aneroid 5 inch	1
Acoustic tubes, set	1	Barometer, mercury	1
Adhesion disks, glass	1	Barometer tube, glass with thick wall, approx. 80cm long with mercury cup and pipette	1
Air pump and plates: <i>select</i>	1	Batteries and cells	
Hand pump		Daniel cell	
Vacuum and pressure, electrically driven,		Demonstration cell with porous cup and elements	8
Air pump plate with stopcock	1	Storage 45-volt.	1
Air thermometer bulb	16	Battery jars: <i>select</i>	
Ammeters: <i>select</i>		4 pint	16
for variety of ranges, A.C. & D.C. A.C. portable laboratory type:		Bell, electric	16
0-2 or 0-5 amp	1	Bell in vacuo, with jar and suspended bell	1
0-10 or 0-15 amp	1	Bell jars: <i>select</i>	
0-1 amp	1	Open form	1
D.C. Millimeter	1	Straight form, 2 to 4.1	1
D.C. 0-2 or 0-5 amp	1	Blocks, wooden, rectangular	16
D.C. 0-10 or 0-15 amp	1	waterproofed	
D.C. Triple range	1	Loaded	32
Ampere's frame app.	1	Normal weight	32
Ampere's rule app.	1	Boyle's law apparatus <i>select</i>	
Anemometer model	1	Flexible tube form	1
Balance:		Iron	1
Beam, single, heavy duty, cap. 2000 g,	4	Bucket and cylinder, Archimedes' principle	1
Beam, triple cap. 1610 g. sensitivity 0.05 g	1	Burettes: <i>select</i> Geissler 30ml	
Flat face or linear 500 g. 16 oz.	32	Burners: <i>select</i>	
Balance support for specific gravity determination	1	Alcohol or Bunsen	12
Balls and ring, to shew expansion	1	Calipers to	
Balls white	16	Micrometer, 0.25mm by 0.01mm	16
Bar, compound	1	Vernier, 12cm metric	48
Bar, soft iron	32	Calorimeter: <i>select</i>	
Barograph	1	Aluminium or brass, polished with stirrer and cover	16

<u>Item</u>	<u>Physics</u>	<u>Item</u>	<u>Physics</u>
Camera	1	Convection of liquids apparatus	1
Camera obscura (pinhole)	1	Crane boom apparatus	1
Candle holders, to slide on meter & candles stick <i>select</i>	16	Crooke's tube	1
Capillary tubes, set	1	Cubical expansion apparatus	1
Cathode ray tube, demonstration form	1	Cylinders: <i>select</i>	
Cathode ray tube, magnetic effect	1	Aluminium	
Catskin	16	Brass	
Center of gravity apparatus	1	Copper	16
Cart, dynamics	16	Steel	
Charles' law tube, Waterman form	1	Water - proofed wood	
Choke coil and resonance apparatus	1	Dewpoint apparatus	1
Clamps		Diffusion of gas apparatus	1
Burette		Diffusion of liquids apparatus	1
Double	16	Discharger, electrostatic jointed type	1
Mohr's (pinch clamp)	16	Dishes	
C-clamp (4"3"2")	32	Evaporating	
Universal, swivel	16	Porcelain	16
Cloud chambers	1	100mm diameter	
Cobalt glass plates, 2 x 2"	1	Disks, acoustic	1
Coil, introduction, primary and secondary: <i>select</i>	16	Disks, color	1
Compasses, magnetic: <i>select</i>		Dosi meter (with adapter)	16
25mm diameter	16	Dynamo, hand-powered dissectible	1
45mm diameter	16	Dynamo and motor set	1
Composition of force apparatus: Board, with spring balances	6	Electromagnets: <i>select</i>	
Table, graduated aluminium top	16	Commercial form	1
Conductivity of solutions apparatus	1	U-form	16
Connectors, double, brass	16	Electroscope: <i>select</i>	
Constant level tubes: <i>select</i>		Metal box	16
Communicating vessels	1	Electrostatic demonstration set	1
Convection apparatus, box with chimneys	1	Flashlight	16
		Fluorescent tubes	2
		Fluorscope	1
		Galvanometers: <i>select</i>	
		D' Arsonval	1
		Demonstration	1
		Portable	16
		Tangent	1

<u>Item</u>	<u>Physics</u>	<u>Item</u>	<u>Physics</u>
Gas engine, demonstration model	1	Mechanical equivalent of heat apparatus	16
Gasoline and Diesel engine working model	1	Meter, stick, English and metric	16
Geiger counter	1	Mirrors, <i>select</i> for material and shape Cylindrical, concave and convex, metal	1
Gyroscope: <i>select</i> type	1	Plane, glass, 10 x 15cm	16
Hooke's law apparatus	16	Spherical Concave and convex glass or metal for optical bench use	16
Hot plate, electric	1	Demonstration, glass concave, 40cm diameter	1
Hydraulic press model	1	Demonstration, glass concave, 40cm diameter	1
Hydrometers; with jar	1	Monochromatic flame attachment for Bunsen burner	1
Demonstration	1	Motor - generator set	1
Universal	1	Newton's ring apparatus	1
Hydrometer, wet and dry bulb	1	Optical bench, with accessories	16
Illuminator	16	Osmosis apparatus: <i>select</i>	1
Inclined planes; <i>select</i>	16	Members bag	1
Board with pulley	16	Pack dry ice	32
Index of refraction plates	1	Photometer: <i>select</i>	1
Inverse square illustration frame	1	Bunsen form	1
Jack, screw model	1	Platinum wires, with glass handles	1
Kilowatt hour dial	1	Power unit, electric a.c. input, variable output, a.c. and d.c.	1
Lamps, electric, glow Neon	16	Prisms: <i>select</i>	
Lenses: <i>select</i> for type diameter, and focal length		Equilateral	16
Double convex set, consisting of concaveconvex, convexo-concave; double concave, double convex, plano-concave; and plano-convex	16	Right angle, flat	16
Levers: <i>select</i>		Protractors: <i>select</i>	
Simple (meter stick)	16	Brass	12
Leyden jar	1	Plastic	16
Light source, parallel rays, <i>select</i>	16	Pulleys: <i>select</i>	
Linear expansion apparatus		Single )	
<i>select</i> Cowan form	16	Double )	16
Magnets: <i>select</i> for type and size		Triple )	
Steel Bar, pair	32	Quadruple)	
Horseshoe	16	Rectifiers: <i>select</i>	
Magnetic needle and support		Dry plate	1
Dipping	1	Tungar	1
Horizontal	1	Refraction cube	1

<u>Item</u>	<u>Physics</u>	<u>Item</u>	<u>Physics</u>
Refraction tank, with protractor	1	Steam engine, <i>select</i> Demonstration, cut-away	1
Resistances, electrical, <i>select</i> Resistance board	1	Stop watch, <i>select</i>	16
Resistance box plug form	16	Stroboscope (hand)	32
Resonance tube, red and piston	1	Support <i>select</i> (motor driven)	32
Rheostats; (6-ohm) Slide wire	16 16	Lamp socket (for meter stick)	16
Ring stands with three rings: <i>select</i>	16	Surface tension apparatus	1
Rods for expansion apparatus: <i>select</i> Aluminium ) Brass ) Copper ) Soft iron ) Steel )	16	Switches, electrical <i>select</i> Knife Single pole single throw Single pole double throw Double pole double throw	16 16 16 16 16
Screens, for light source: <i>select</i> Double slit Single slit	1 1	Tank, ripple (with stand)	16
Second law for motion apparatus	16	Telegraph set: key, sounder, relays	2
Silk pad	16	Telephone set; receiver, transmitter	2
Sockets, electrical: <i>select</i> Standard	48	Telephone induction coil	2
Sonometer: <i>select</i> Sprint tension, key tension, or weight tension type Advanced type Simple type	1 1	Thermostat, bimetallic adjustable	1
Specific gravity bottles: <i>select</i> for size	1	Transformer, demonstration	1
Spectroscopes, <i>select</i> Direct vision	1	Tubes Resonance	16
Spectrometer with grating	1	Tuning forks, <i>select</i> one active, set sympathetic, pair mounted on resonance boxes	1 1
Spring, spiral, for wave motion	1	Vacuum discharge tube	1
Spring 2cm diameter by 15cm long	16	Voltmeters: <i>select</i> A.C. Voltmeter to 300v Single scale Double scale Triple scale D.C. triple scale, portable, laboratory type 1.5-3-30v D.C. triple scale, portable laboratory type 1.5-15-150v.	1 1 1 16 16

<u>Item</u>	<u>Physics</u>
Watch glasses: <i>select</i> by size 7.5cm diameter	32
Wave generator, with support	16
Weights: <i>select</i> General laboratory, in block 1 to 500 or 1 to 1000g, set	6
Wheatstone bridge, slid wire form	16
Wheel and axle	1
X-ray tube	1

MATERIALS AND SUPPLIES

- Air pump tubing
- Aluminium foil
- Asbestos, mats
- Asbestos, rope, sheet, or shredded
- Battery, "B", 45v
- Beakers, round and flat bottoms  
*select* by size  
250 ml.  
600 ml.  
1000 ml.
- Bottles, glass:  
*select* Balsam  
Dropping; Barnes'  
Schuster's  
Narrow mouth  
2, 4, 8, 16, 32, oz.  
Narrow mouth glass  
stoppers  
4, 8, 16 oz.  
Narrow mouth glass  
stoppers, regent  
bottle, 4 oz. *select*  
by number of sets.  
Wide mouth  
2, 4, 8, 16, 32, oz.
- Belts and nuts, *select*  
Variety of diameter and  
lengths
- Brush, beaker
- Brush, test tubes
- Carbon
- Cellophane sheets, *select*  
Clear  
Coloured
- Celluloid sheets
- Cement, *select*  
Airplane  
Aquarium  
DeKhotinsky  
Household  
Rubber
- Clay, modeling
- Clothes pins
- Copper
- Cord, cotton
- Cord, pulley
- Cork
- Developer, photographic, *select*  
Variety of formulas
- Dry cells  
Flashlight Ni.6:
- Enlarging paper, photographic
- Erlenmeyer flask  
250 ml.  
Volumetric  
250 ml.
- Files, triangular
- Film, photographic, *select* by  
camera available and purpose
- Fixer, photographic
- Flasks, pyrex, *select*  
supplies purpose and size:  
Boiling, flat bottem  
250, 500, 1000 ml.
- Foil  
Aluminium  
Gold
- Friction tape
- Funnels, glass: *select*  
diameter  
75mm diameter
- Fuse wire
- Gauze, wire  
With or without asbestos centre
- Glass sheet
- Insulating material, heat
- Iron filings

Labels, gummed  
Lamps, electrical  
    miniature 1 v  
Lead  
Medicine droppers  
Membranes, osmosis  
Metal sheet, *select*  
    Aluminium, copper, lead  
    zinc  
Nails, *select* by type and  
    size  
Oil  
    Lubricating  
Paint  
Paint brushes  
Paper *select*  
    Graph  
    Lens  
    White  
Paraffin  
Paste  
Plastic sheet  
Print paper, photographic  
Pumice powder  
Sandpaper  
Screws, *select* by type and  
    size  
    Round-head and flat-head  
    Wood, machine, and *self*  
    threading  
Screw eyes, assorted  
Sealing wax  
Soap  
Sponges, *select*  
    Natural and manufactured:  
Steel wood  
Stirring rods, glass  
Stoppers, *select* by quality  
    and size  
    Cork, size 000 to 26  
    rubber, 00 to 13

Tacks  
    Carpet and thumb  
Tape  
    Cellophene and gummed  
    paper  
Thread, cotton  
Tubing, rubber *select* by  
    *inside diameter, quality,*  
    *thickness of wall*  
    Diameter  $\frac{1}{8}$  to  $\frac{1}{2}$ "  
    Quality: white, red, black  
    Wall thickness: thin, medium  
    heavy  
Vaseline  
Wax  
    Sealing  
    vacuum  
Wire, *select* by quality, size,  
    *insulation stranding*  
    Quality: copper, iron, steel,  
    nichrome, German silver,  
    aluminium, brass,  
    Size, No.10 to No.36  
Zinc

CHEMICALS FOR PHYSICS TEACHING

Acetamide, pure	Glue, quick-drying
Acid, citric, CP	Éther, ethyl, pure
Acid, hydrochloric, CP	Lead metal, sheet
Acid, sulphuric, CP	Mercury metal, tech. Methyl alcohol
Alcohol, ethyl, denatured	Napthalene flasks
Aluminium metal, coil and powder	Nickle ammonium sulphate, pure
Ammonium hydroxide, CP conc.	Paraffin (liquid)
Ammonium nitrate, granular, CP	Potassium permanganate
Ammonium chloride pure	Potassium chloride
Calcium	Sodium chloride, white fine, pure
Carbon disulphide, pure	Oline acid, pure
Carbon Tetrachloride, pure	Sodium chloride, white fine, pure
Copper metal, sheet	Sodium nitrate, CP
Copper (ic) sulphate, crystals, CP	Strontium nitrate, pure
Cupric Chloride	Zinc metal, sheet
Dry ice	



AUDIO-VISUAL EQUIPMENT AND SUPPLIES FOR PHYSICS TEACHING

Cameras: *select*

35mm  
Box

Charts: *select (the titles given are representative of a large number of single charts and sets)*

Acoustics  
Astronomy  
Atomic structure  
Color  
Electromagnetic radiations  
Metric system  
Physics

Exposure meter, photographic

Film splicer, 16mm

Filmstrips: *select (the titles given are representative of a wide range)*

Air, Ocean  
Atmosphere  
Atomic Energy  
Cloud Formations and Air Masses  
Current Electricity  
Electricity  
Electromagnetism  
Energy  
Fire and Heat  
Flight, Theory of,  
Forest Conservation  
How Young Birds Get Food  
Liquid Pressure  
Simple Machines

Microphones

Carbon  
Crystal

Models: *select (the titles given are representative of a wide range)*

Airplane  
Engine, diesel, gas, steam  
Planetarium

Motion Picture Films: *select (the titles given are representative of a wide range)*

Atomic Energy  
Electricity, The Flow of Endocrine Glands  
Energy and its Transformations  
Matter and Energy  
Sound Waves and Their Sources  
Universe, Exploring the Unseen Worlds  
Vacuum Tubes  
What is Science?

Projection cell, lantern slide

Projectors;

Filmstrip  
Filmslide  
Lantern slide  
Microprojector  
Motion picture projector  
Opaque Projector

Radio Receiver

Recorder, with playback for recorder and recordings

Screen, Projection

Slide-making set, lantern

Slides, Lantern, sets; *select (the titles given are representative of a wide range of sets of lantern slides)*

Atoms, Isotopes, and Radioactivity  
Electricity, Fundamentals of Food  
Heat and Fire  
Light  
Light, Fundamentals of  
Machinery  
Machines, Fundamentals of  
Sound  
Static Electricity

Specimens, Biological; *select*

Tackboards

Television Receiver

DARKROOM EQUIPMENT

Balances and weights

Enlarger, photographic

Film clips

Graduated cylinders

Lamps, darkroom

Print box

Print drier

Print frame

Print roller

Stirring paddles

Suspension wire

Tank, developing, day-load

Thermometers

Timer, interval, with bell

Trays, developing

Trimmer

MINIMUM LIST OF EQUIPMENT FOR PHYSICS TEACHING

<u>Description of Article</u>	<u>Detailed Specifications</u>	<u>Standard Quantity</u>
Balance Spring	To weight 500gm, division of 5gm.	1
Balance	Sliding weight triple beam, load 2kgm, with sensitively 0.1gm.	1
Balance Students'	Maximum load 250gms; Sensitivity 5mgms.	3
Barometer, Fortin Type	-	1
Barometer, Aneroid	-	1
Burette	50cc, divided into 1/10cc	1
Cylinder Measuring	Graduated 250cc	6
Hydrometer	Universal type	1
Microscope, Vernier	-	1
Opisometer	-	2
Spherometer	-	2
Hygrometer	Daniell's type	1
Thermopile	Comprising about 20 pairs of Bismuth, Antimony	
Photometer	Rumfords	2
Photometer	Bunsen form	2
Spectrometer	-	1
Ammeter	Moving Coil, 0-5 amps.	2
Dip Needles	4" long	1
Electroscope	Two pith balls	1
Galvanometer	Tangent	2
Galvanometer	Unipivot	2
Magnetometer	Vibration, cylindrical magnet	2
Magnetometer	Vibration, with brass torsion head	2
Post Office Box	-	1
Potentiometer	Comprising 4 constantan or Nichrome wires	1
Voltmeter	One meter reading 0-5 volts	1
Wheatstone Bridge	Moving coil.	2
Burner	Bunsen type	20
Model	Set of Solids - Geometrical	2 sets
Vernier	Demonstration	1
Conductivity Apparatus	Searle's	1

<u>Description of Artical</u>	<u>Detailed Specifications</u>	<u>Standard Quantity</u>
Leslie's Cube	--	1
Chart of the Coloured eye	--	1
Newton's Colour Disc.	Mounted on metal stand with driving wheel and belt	1
Bench Hydrostatic	-	1
Boyle's Law Apparatus	-	1
Hare's Apparatus	-	2
Pulley Double	Aluminium, Tandem 2" & 1 $\frac{1}{2}$ "	2
Pulley Triple	Aluminium, Tandem 2" & 1 $\frac{1}{2}$ " & 1"	2
Pulley differential	Laboratory type	1
Slide rule	12" high quality	1
S.G. Bottles	50cc	6
Young's Modulus Apparatus	Searle's pattern	1
Steam Heaters	-	2
Glass cubes	Glass thin-walled, hollow 6 x 6 x 6 cm	3
Prisms	Luted, hollow, equilateral	1
Kandt's Apparatus	-	1
Organ Pipe	Metal	1
Tuning forks	Set of frequencies - C.D.E.F. G.A.B.C.(oct).	2 sets
Accumulators	2 volts, 60 A.H. Capacity	3
Butterfly Net	Faraday's	1
Calorimeter Joule's	-	1
Condenser Air	-	1
Electrophorus	-	1
Induction Coil	-	1
Ruhmkorff's Magnet	Bell-ended	2
Electro-Magnet	-	1
Rod-Brass	About 12" long	1
Rod-Ebonite	About 12" long	1
Thermo Couple	-	1
Unspun Silk	-	1 reel
Volta meter	For decomposition of water	1
Wimhurst Machine	-	1

<u>Description of Article</u>	<u>Detailed Specification</u>	<u>Standard Quantity</u>
Beakers	Spouted 250 cc	14
Beakers	Spouted 1000 cc	4
Wash jar	Ht. about 12", internal diam. about 6"	2
Glass Heads	Metal, Universal	6
Clamps	Metal, Universal	6
Clip-Burette	Mohr's small	1
Flasks	Flat bottomed, short-necked, medium-wall 500cc	6
Foot Bellows	-	1
Funnels	Diam, about 5"	4
Funnels	Diam. about 6"	4
Pipettes	Capacity 10cc	2
Stands - Burette and Funnels	-	6
Stands - Laboratory	-	6
Stand - Tripod	-	8
Test tubes	Soda Glass, with rim, 6" long diam. 1"	18
Test tube holders	-	9
Troughs	diam. 15"	1
Wire Gauze	6" x 6"	10

## BIBLIOGRAPHY

This bibliography is arranged in five sections: Courses, Curricula and Syllabuses for Physics Education; Physics Teaching in Second Level Schools; Physics Buildings and Facilities; Lists of Physics Equipment; and, The Physical Environment of the Laboratory.

To avoid repetition of titles, each reference is listed only once, but many of the books mentioned are relevant under more than one heading. Many publications dealing with physics teaching also cover the design and layout of the physics laboratory; nearly all books on either physics education or laboratory design contain lists of essential equipment - and so forth.

Whilst some of this Institute's papers are mentioned specifically in this Bibliography others are also relevant to the topic. A list of the Institute's publications may be found on the back of the title-page of this Study and many are still available. For Asian librarians and others interested in school building it is worth mentioning that some of the other material in the Bibliography is available free, or on exchange. The Institute would be happy to direct inquirers to the source where possible.

### 1. COURSES, CURRICULA AND SYLLABUSES FOR PHYSICS.

CAMBODIA. Ministère de l'Éducation Nationale. Programmes de l'enseignement secondaire Khmer. [Phnom-Penh] Rasney [1965] 282p.

CEYLON. Department of Education. Syllabuses of instruction and schemes of work in science subjects for GCE classes: Physics, 1st year (2nd and 3rd terms), 4th term (2nd year), 5th term (2nd year), 6th term (2nd year). Colombo, 1964-7. [4v.]

CEYLON. Department of Examinations. Amended syllabuses in science subjects, Ceylon General Certificate of Education (Ordinary Level) Examination. Effective from the December 1965 examination. Advance copy. Colombo [1965] 59p., illus. (S A 636 (Sc.))

-- Regulations and syllabuses, Ceylon General Certificate of Education (Advanced Level) Examination. Effective from the December 1967 examination. Colombo 1967. 80p.

1. COURSES, CURRICULA AND SYLLABUSES FOR PHYSICS (contd.)

INDIA. National Council of Educational Research and Training.  
Physics. Part 1. Curriculum guide. New Delhi, 1967.  
31p. (Science for middle schools)

-- --- Part 1. Teachers guide. New Delhi, 1967. 43p.

INDIA. National Council of Educational Research and Training.  
Regional Colleges Unit. Demonstration multi-purpose higher  
secondary schools attached to Regional Colleges of Education;  
plan and courses of study. New Delhi, 1964. 477p.

LAOS. Ministère de l'Education Nationale, Des Beaux-Arts &  
Sports-Jeunesse. Enseignement secondaire; programmes de  
sciences. Vientiane, 1964. 103p.

NEW YORK (city). Board of Education. Curriculum bulletin, 1962/63  
series, no.9b: Science, Grade 7; 2. Electricity, magnetism and  
heat. Experimental ed. New York, 1963. 39p., illus., bibl.

-- ---, 1964/65 series, no. 3b: Science, Grade 8; Matter and  
energy in physics. Experimental ed. New York, 1964.  
35p., bibl.

-- ---, 1965/66 series, no. 3b: Science, Grade 9; Wave and mechani-  
cal motion. Experimental ed. New York, 1966. 42p., illus.,  
bibl.

PAKISTAN. Curriculum Committee for Secondary Education (Classes VI -  
XII). Report. General introduction, schemes of studies and  
syllabuses. Rawalpindi, ECRIU [1960?] 653p., & supplement.

VIETNAM. Secrétariat d'État à l'Education Nationale. Programme  
de l'enseignement secondaire. [Saigon] 1960. 187p.

2. PHYSICS TEACHING IN SECOND LEVEL SCHOOLS

AFGHANISTAN. Ministry of Education. Education in Afghanistan  
during the last half-century. [Kabul] n.d. 96p., illus.

BERGVALL, PAR and JOEL, NAHUM. Unesco Pilot Project on New Methods  
and Techniques in Physics Teaching. São Paulo, Brazil, 1964.  
80p., illus.

BOULIND, H. F. The teaching of physics in tropical secondary  
schools. London, Oxford University press, 1957 (repr. 1964).  
394p., illus. (Unesco. Handbooks on the teaching of science  
in tropical countries, v.8.)

CASSIRER, HENRY H. Television teaching today. Paris, Unesco, 1960.  
267p., illus., bibl. (Unesco. Press, film and radio in the  
world today.)



2. PHYSICS TEACHING IN SECOND LEVEL SCHOOLS (contd.)

CESSAC, J. Science teaching in the secondary schools of tropical Africa. Paris, Unesco, 1963. 79p., illus.

EDUCATIONAL SERVICES INCORPORATED. I P S Group. Introductory physical science. Englewood Cliffs, N.J., Prentice-Hall, 1967. 227p., illus.

-- Physical Science Study Group. Physics; laboratory guide. [Boston] D. C. Heath and co., 1960. 87p., illus.

GHOSH, BINA, SINHA, A. K. and NAGCHAUDHURI, B. D. A review of some approaches to physics teaching. School science (India. National Council of Educational Research and Training.) v.5, no.3. (Sept) 1967, p.185-196.

GREAT BRITAIN. Ministry of Education. Pamphlet no.38: Science in secondary schools. London, H.M.S.O., 1960. 164p., illus.

INDIA. Committee on Plan Projects. C O P P / S S / 3 / 1964: Report on science education in secondary schools. New Delhi, 1964. 67p., 3 plates.

INDIA. National Council of Educational Research and Training. Position of science teaching in Indian schools; a factual report. [Delhi, 1962] 156p.

-- Science in our schools. New Delhi, 1966. 12p.

IRAN. Ministry of Education. Present educational system in Iran [by] Mohammad Ali Toussi. Tehran, 1966. 40p.

JAPAN. Ministry of Education. Educational standards in Japan; the 1964 "White Paper on Education". [Tokyo] 1965. 222p. (M E J 6619)

JOINT COMMITTEE OF THE INCORPORATED ASSOCIATION OF ASSISTANT MASTERS AND THE SCIENCE MASTERS' ASSOCIATION. The teaching of science in secondary schools, compiled by [the] ... Joint Committee. Rev (2nd) ed. London, John Murray, 1958 (repr. 1966). 274p., illus., bibl.

NUFFIELD FOUNDATION. Science Teaching Project. Chemistry background books; the discovery of the electric current. London/Harmondsworth, Longmans/Penguin, 1967.

-- Nuffield physics; guide to experiments. London/Harmondsworth, Longmans/Penguin, 1967. 5 pts.

-- ---; question books, 1 - 4. London/Harmondsworth, Longmans/Penguin, 1966. 4 pts.

-- ---; teachers' guide, 1 - 3. London/Harmondsworth, Longmans/Penguin, 1966-67. 3 pts.

## 2. PHYSICS TEACHING IN SECOND LEVEL SCHOOLS (contd.)

PHYSICAL SCIENCE STUDY COMMITTEE (P S S C). The teacher's resource books. Pts.1 to 4. [Boston, D. C. Heath?].

SAUNDERS, H. M. The teaching of general science in tropical secondary schools. London, Oxford University press, 1955 (repr.1967). 379p., illus., bibl. (Unesco. Handbooks on the teaching of science in tropical countries, v.7.)

SHAPOVALENKO, S. G., ed. Polytechnical education in the U.S.S.R. Paris, Unesco, 1963. 433p., illus., bibl. (Unesco. Monographs on education, 3.)

SHARAN, B. Reorganization of practical training in physics.II. School science (India. N.C.E.R.T.) v.5, no.3 (Sept) 1967, p.225-233. NOTE: Part I appeared in School science, v.5, no.2 (Mar) 1967, but was not seen.

SINGAPORE. Commission of Inquiry into Education. Final report. [Singapore, Government Press, 1964] (Cmd.8 of 1964.) Chapter 10: Teaching of science in schools.

UNESCO. New trends in physics teaching / Tendances nouvelles de l'enseignement de la physique. v.1, 1965-1966; prepared by / préparé par, W. Knecht. Paris, Unesco, 1968. 271p., illus., bibl.

-- Source book for science teaching. Rev. and enl. ed. Paris, 1962. 224p., illus., bibl., tables.

-- A survey of the teaching of physics at universities. Prepared under the auspices of the International Union of Pure and Applied Physics. Paris, 1966. 396p.

-- Planning Mission for the Technical Assistance Project in India for the Improvement of Secondary School Science Teaching, 1964, Science and mathematics education in Indian schools; report. New Delhi, National Council of Educational Research and Training, 1965. 215p.

## 3. PHYSICS BUILDING AND FACILITIES

AMERICAN INSTITUTE OF PHYSICS. Checklist for physics buildings. New York, 1965. 19p., bibl. (American Institute of Physics. Pub.R-178.)

-- Physics buildings today; a supplement to Modern physics buildings; design and function. New York, 1965. 64p., illus. (American Institute of Physics. Pub.R-180.)

3. PHYSICS BUILDINGS AND FACILITIES (contd.)

ARCHITECTS' journal. London, Architectural Press Ltd. Various parts as follows: 30 Oct. 1963, p.891-910; 6 Jan 1965, p.43-54; 19 Jan 1965, p.99-116; 3 Feb 1965, Information Sheets 1312(6 sheets); 21 Apr 1965, p.941-954; 27 Apr 1966, p.1965-6.

AUSTRALIA. Commonwealth Advisory Committee on Standards for Science Facilities in Independent Secondary Schools. The design of science rooms. Canberra, 1966. 56p., illus.

BOYCE, R. DUDLEY, ed. New dimensions in junior college planning. Standard, Calif., School Planning Laboratory, 1958. 111p., illus.

BUILDING bulletin (Gt. Brit. Dept. of Education and Science.) no.17: Development projects; secondary school, Arnold. Lond., HMSO, 1960. 92p., illus.

-- 25: Secondary school design; sixth form and staff. Lond., HMSO, 1965. 45p., illus.

-- 29: Harris College, Preston. Lond., HMSO, 1966. 96p., illus.

BURMA. P.W.C.(?). Architect Department. School building design in Burma. [Rangoon] 1967. 20p., illus.

FRANCE. Direction de l'Equipement Scolaire, Universitaire et Sportif. Service Technique. Bâtiments d'enseignement, schemas, types: installations scientifiques; second degré. [Paris] 1960. (Institut Pédagogique National. Brochure 156DA.) 46 plans.

GREAT BRITAIN. Scottish Education Department. Educational building notes, 5: Secondary school science rooms. Edinburgh, Her. Majesty's Stationery Office, 1965. 16p., illus.

HOUSTON UNIVERSITY. Bureau of Education Research and Services. Publication 15: Educational specifications for Hull-Daisetta High School, Liberty County, Texas. Houston, 1965. 178p., illus.

INDIA. Panel on School Buildings. Special Committee. Central school buildings; norms and specifications. Delhi, 1964. 27p., plans, illus.

INSTITUTE OF PHYSICS. The design of physics research laboratories; a symposium held by the London and Home Counties Branch of the Institute ... on 27 November 1957. London, Chapman and Hall, 1959. 108p., illus., bibl.

3. PHYSICS, BUILDINGS AND FACILITIES (contd.)

MARTIN, W. EDGAR. Facilities and equipment for science and mathematics; requirements and recommendations of state departments of education. Washington, D.C., 1960. 130p., illus. (U.S. Office of Education. Misc. no. 34) (U.S. Dept. of Health, Education and Welfare. O E-21000.)

MUNCE, JAMES F. Laboratory planning. London, Butterworths, 1962. 360p., illus., bibl.

NATIONAL COUNCIL FOR SCHOOLHOUSE CONSTRUCTION.. Guide for planning school plants. 1964 ed. n.p., 1965. 156p., illus.

NEW YORK (state). Education Department. Division of School Buildings and Grounds. [Publication] 19: Planning science facilities for secondary schools. Albany, 1960. 16p illus.

PALMER, R. RONALD *and* RICE, WILLIAM MAXWELL. Laboratories & classrooms for high school physics. A report of the American Institute of Physics' Project on Design of Physics Buildings. New York, Educational Facilities Laboratories, n.d. 31p., illus., bibl. (Case studies of educational facilities, 3.) Chapter 12 of: Modern physics buildings; design and function.

-- Modern physics buildings; design and function. A project of the American Association of Physics Teachers and the American Institute of Physics. New York, Reinhold Publishing corp., 1961. 324p., illus., bibl.

SAVAGE, Sir GRAHAM. The planning and equipment of school science blocks. London, Murray, 1965. 78p., illus.

SOUTH AFRICA. National Building Research Institute. School Buildings Committee. [School Building series; report] 4: Die ontwerp van klaskamers en spesiale kamers vir hoërskole / Planning of classrooms and special rooms for high schools. [Pretoria] 1962. 68p., illus., bibl. (C.S.I.R. research report, no. 148.)

STANFORD. UNIVERSITY. School of Education. Educational administration monographs, no. 2: Science facilities for the modern high school by Paul deH. Hurd. Stanford, Calif., 1954. 52p., illus.

UNITED STATES. Office of Education. Special publication no. 5: The secondary school plant; an approach for planning functional facilities, by James L. Taylor. [Washington, D.C.] 1956. 60p., illus., bibl.

4. LISTS OF EQUIPMENT FOR PHYSICS LABORATORIES

(Apart from the few publications listed below, and those from other sections above which contain lists of equipment, the authors also studied many trade catalogues and leaflets containing physics equipment and furniture, in order to be fully aware of the range, variety, size and storage problems of physics equipment.)

NEW ENGLAND SCHOOL DEVELOPMENT COUNCIL. Industry Aids to Education. Annual report, 1st, 1959. Boston., Mass., 1960. 46p., illus.

UNICEF. Guide list EVE; equipment and supplies for primary schools, secondary schools, teacher training institutions, production units. New York, 1964. 184p. (Unicef. S U N O - 20)

5. THE PHYSICAL ENVIRONMENT IN THE LABORATORY

ARCHITECTURAL ASSOCIATION. Paper, no.1: Roofs in the warm, humid tropics [by] O. Koenigsberger and R. Lynn. London, Lund Humphries, 1965. 56p., illus., bibl.

ASIAN REGIONAL INSTITUTE FOR SCHOOL BUILDING RESEARCH. Occasional papers; school building no.3: Comparative anthropometric data A - For use in Indian schools, by D. J. Vickery. Bangkok, Unesco Regional Office for Education in Asia, 1964. 5p., illus., bibl., tables.

-- --- no.4: Comparative anthropometric data, B - For use in Thai schools, by D. J. Vickery. Bangkok, Unesco Regional Office for Education in Asia, 1964. 12p., illus., bibl., tables.

-- --- no.5: Comparative anthropometric data, C - For use in Indonesian schools, by D. J. Vickery. Bangkok, Unesco Regional Office for Education in Asia, 1964. 12p., illus., bibl., tables.

-- --- no.6: Comparative anthropometric data, D - Application of data, by D. J. Vickery. Bangkok, Unesco Regional Office for Education in Asia, 1964. 10p., illus.

-- --- no.8: Comparative anthropometric data, E - For use in Philippine schools, by the Philippine National School Building Development Group. Bangkok, Unesco Regional Office for Education in Asia, 1964. 10p., illus., bibl.

-- Comparative anthropometric data for use in East Pakistan schools, by D. J. Vickery. Bangkok, Unesco Regional Office for Education in Asia, 1966. 16p., illus.

5. THE PHYSICAL ENVIRONMENT IN THE LABORATORY (contd.)

INDIA. Central Building Research Institute, Roorkee. Building digest, no.40: Fenestrations for daylighting, in the tropics. Pt.I: The sky component. (Compiled by V. Narasimham. Roorkee, 1966.) 8p., tables, graphs.

JAPAN. Ministry of Education. Educational Facilities Division. School buildings in Japan. Tokyo, 1967. 121p., illus.

MCCRACKEN, EARL C. and RICHARDSON, MARTHA. Human energy expenditures as criteria for the design of household storage facilities. Journal of home economics, v.51, no. 3 (Mar) 1959, p.198-206

SOUTH AFRICA. National Building Research Institute. [School building series, report] no.10: School lighting, by W. M. H. Rennhackkamp. Pretoria, 1964. 47p., illus., tables, bibl.

I N D E X

- ACCOMMODATION  
Standards *see* STANDARDS  
Accommodation
- AGE-RANGE  
Second-level schools, 1
- ANTHROPOMETRICS  
Asian children, 13-18
- AUDIOVISUAL EQUIPMENT, 82-3
- BATTERIES  
Storage, 31  
Use, 24, 31
- BENCHES *see* DEMONSTRATION  
TABLE, WORK-TABLES
- BOOKS  
and Bags, 34, *Fig. 18*  
Shelves, 35, 44-5, *Fig. 19*  
Storage, 34-5, 44-5, *Figs. 18-19*
- CART, Mobile *see* MOBILE CART
- CHARTS AND DIAGRAMS  
Display, 34  
Storage, 36, 44-5, *Fig. 20*
- CLASSES  
Grouping, 27  
20-place, 56-67  
40-place, 44-55  
Sizes, 40, 43
- CLIMATE, 21-3, 39, 43  
Cold, 50-61  
Dry, 50-61  
Humid, 44-9, 62-7
- CRAMPING  
Working surface for, 31,  
*Fig. 12*
- CUPBOARDS  
Ordinary, 69, 71  
Wall, 32, 44-5, 50-7, 71  
Warmed, 70, 71
- DARK ROOM, 40  
Areas, 42  
Requirements, 42
- DEMONSTRATION TABLE, 37, 44-5, *Fig. 21*  
*see also* STUDENT PROJECTS  
Work-tables
- DEMONSTRATIONS, 1, 9-10
- DIMENSIONS  
Areas, 40-3  
Body sizes, 13-18  
Furniture, 13-18
- DIRECTED READING, 11-12  
Shelves for, 12, 35, *Fig. 19*
- DISCUSSION, 1, 5, 6, 11, 25, 46-7, 52-3,  
58-9, 64-5
- DISPLAY  
Board, 34  
Table, 34
- DRAWERS, 69-71
- EDUCATIONAL REQUIREMENTS, 2, 5, 6,  
7-12, 24-8, 31, 34, 35-7, 40, 43
- ELECTRICITY  
Lighting, 19  
Power, 24, 25, 46-7, 52-3, 58-9, 64-5,  
*Table III*
- ENVIRONMENT, 12, 13-23
- EQUIPMENT, 69-87  
Lists, 73-87  
Preservation & protection, 70  
Storage, 32-3, 41-2, 69-70  
Usage, 69-70
- EXPERIMENTAL WORK, 1, 5, 6, 8-9, 25, 26,  
28, 46-7, *Fig. 9*
- FACILITIES *see* SERVICES

- FILMS, 1  
Equipment for, 82-3  
Mobile cart, used for, 37
- FURNITURE, 5  
Arrangements, 26, 46-7, 52-3, 58-9, 64-5  
Movable, 1, 25  
Sizes, 5, 13-18, 28-37  
Wheel cart, 37, *Fig. 21*  
Wooden, 1  
*see also* DEMONSTRATION TABLE,  
WORK-TABLES
- GANGWAYS *see* PASSAGE-WAYS
- GROUP WORK, 1, 27, 42, *Fig. 8*
- HEAT, 24, 25, 31  
Protection against  
Corrosion, 70  
*see also* SOLAR HEAT
- ILLUMINATION *see* LIGHTING
- LABORATORIES, 8, 39-68  
Dimensions, 41, 42, 44-67  
Lit from both sides, 44-9, 62-7  
Lit from one side, 50-61  
Shape, 41
- LAYOUTS  
20-place laboratory, 56-67  
40-place laboratory, 44-55  
Flexibility, 12, 40  
Key to layouts, 43  
Problems, 39-40
- LECTURES, 9, 25-6  
Accommodation, 5
- LIGHTING, 18-21, 39, 41  
Daylighting, 19-20, 44-5, 49, 50-67  
Electric lighting, 19  
Minimum requirements, 19  
*Table II*
- MOBILE CART, 37, *Fig. 21*
- MOBILE FURNITURE, 1, 25, 26, 27-30, 37
- MOVABLE FURNITURE  
*see* FURNITURE  
Movable  
MOBILE FURNITURE  
WORK TABLES  
Movable
- ORIENTATION of buildings, 21-2
- PASSAGE-WAYS, 18
- PHYSICS  
Syllabus *see* SYLLABUS  
Teaching, 7-12, 25
- PLACES *see* CLASSES
- PREPARATION ROOM, 40  
Areas, 42
- PROJECTS *see* STUDENT PROJECTS
- RIPPLE TANKS, 24, 46-7, 52-3, 58-9, 64-5
- RURAL SCHOOLS, 39
- SCHOOLCHILDREN  
Ages  
Second-level, 1  
Sizes, 13-14
- SEATS  
Area, 15  
Height, 15  
In relation to working surface, 15
- SERVICES, 24-5
- SHELVES  
Books and periodicals, 35, *Fig. 19*  
Equipment storage, 70-1
- SITTING, 15-16, *Fig. 2*
- SOLAR HEAT, 21-2  
Resistant materials, 22
- SPACES, 41-2  
Class size, 40  
Furniture spacing, 13-18  
National standards, 41-2  
Per pupil place, 41-2  
Relationships, 40



STANDARDS

Accommodation  
Laboratories  
per place, 5  
spaces, 40

STANDING, 14, 16, *Fig. 2*  
Height of working surface, 14  
and Reaching, 16-17

STORAGE, 16-17, 32-3, 42, 56, 59-71  
Bags and books, 34, 44-5, *Fig. 18*  
Fixed work-tables, 32, *Fig. 15*  
Location, 39, 50-67  
Provision for expansion, 68  
Store-room see STORE ROOM  
Under-bench, 32  
Wall cupboards, 32, 44-5, 50-7

STORE ROOM, 32-3  
Access hatch, 33, 44-5, *Fig. 16*  
Dimensions, 41-2

STUDENT PROJECTS, 10-11  
Work tables, 33, 44-5, *Fig. 17*

SYLLABUS, 1

TABLES

see DEMONSTRATION TABLE  
WORK-TABLES

TEACHER'S ROOM, 40

Areas, 42

TEACHING methods

Demonstration method see  
DEMONSTRATIONS

Experimental method see  
EXPERIMENTAL WORK

Furniture arrangements,  
46-7, 52-3, 58-9, 64-5

Pupil-centric, 1, 5, 6

Teacher-centric, 1, 5, 6

THERMAL COMFORT, 21-3

Cold areas, 21-3, 50-61

Dry zone, 21-3, 50-61

Humid zone, 21-3, 44-49

VENTILATION, 22-3, 39, 62, 70, *Fig. 7*

WATER

Non-piped, 31

Running, 24, 25

Sinks, 31

WHEELED CART see MOBILE CART

WORK-TABLES

Demonstration see DEMONSTRATION  
TABLE

Depth, 14, 31

Fixed, 31, 44-5

Height, 14, 28

Length, 15, 28

Movable, 26, 27-30, 44, 47, 49, 53, 55,  
59, 61, 65, 67

Prototype, 30 *Plates 1 & 2*

Student projects, 33, *Fig. 17*