

DOCUMENT RESUME

ED 033 564

EF 003 754

AUTHOR Fohle, Frederick C.  
 TITLE The Application of the Systems Approach to School Building in Toronto.  
 Pub Date Oct 69  
 Note 60p.; Address to the Regional Conferences on a Systems Approach to Buildings, Sponsored by the Dept. of Industry, Trade and Commerce, Ottawa, Canada

EDRS Price MF-\$0.25 HC-\$3.10  
 Descriptors \*Component Building Systems, Construction (Process), Construction Needs, \*Construction Programs, Facility Expansion, Facility Guidelines, \*Modular Building Design, School Buildings, \*School Construction, \*School Design, Systems Approach

Identifiers SEF, Study of Educational Facilities

Abstract

A description is presented of the building system program developed by the Metropolitan Toronto School Board, Study of Educational Facilities. The organization of the project is discussed, and the rationale is presented for the selection of an open systems approach to the School Board's building needs. Detailed information is given regarding the SEF Building System's 10 sub-systems and to principal non-system items; a sub-system is an identifiable, complete, designed, physically integrated, dimensionally co-ordinated, installed series of parts, which function as a unit without prescribed performance limits. Specific requirements are presented regarding an overall time program for the project, program budget, bidding procedures, and quality control procedures. Consideration is also given to codes and standards, bids and bid evaluation, and individual project construction.  
 (FS)

ED033564

ADDRESS TO

THE REGIONAL CONFERENCES ON A SYSTEMS  
APPROACH TO BUILDING

Sponsored by

THE DEPARTMENT OF INDUSTRY, TRADE & COMMERCE - OTTAWA

THE APPLICATION OF THE SYSTEMS APPROACH TO  
SCHOOL BUILDING IN TORONTO /

by

RODERICK G. ROBBIE

of

ROBBIE, VAUGHAN, WILLIAMS & JACQUES SYSTEMS  
(RVWJ SYSTEMS)

ROBBIE, VAUGHAN, WILLIAMS & JACQUES  
ARCHITECTS AND TOWN PLANNERS

of

TORONTO AND ALBANY (NY)

and

Technical Director

The Metropolitan Toronto School Board  
Study of Educational Facilities (SEF)

October, 1969.

U.S. DEPARTMENT OF HEALTH, EDUCATION & WELFARE  
OFFICE OF EDUCATION

THIS DOCUMENT HAS BEEN REPRODUCED EXACTLY AS RECEIVED FROM THE  
PERSON OR ORGANIZATION ORIGINATING IT. POINTS OF VIEW OR OPINIONS  
STATED DO NOT NECESSARILY REPRESENT OFFICIAL OFFICE OF EDUCATION  
POSITION OR POLICY.

EF 003 754

## THE APPLICATION OF THE SYSTEMS APPROACH TO SCHOOL BUILDING IN TORONTO

The following statistics are presented simply to show the scale of problem which faces the Metropolitan Toronto School Board, and are not presented as a boost for bigger and better Toronto. They also, I hope, will enable you to place your judgment of the SEF project in its context.

### Organization of the Project

Metropolitan Toronto comprises five Boroughs and the City of Toronto, it has a current population just in excess of two million. It is growing currently at the rate of 55,000 people per annum. It is expected to reach 4 million by the mid-eighties, and could be approaching 7 million by the year 2000.

The Metropolitan Toronto School Board is the fourth largest school board in North America after New York, Los Angeles and Chicago. It has 460,000 students, 20,000 teachers, 2,500 officials, 544 schools, and a gross annual operating budget of about \$360 million, and an annual capital budget of \$80 million. Each year the Board must build 20 to 30 schools, plus many additions and alterations. The Board currently owns 1,200 portable classrooms accommodating 40,000 students, a bus fleet about the same size as that owned by the Toronto Transit Commission, and about 100 obsolete schools.

The problem facing the Metropolitan Toronto School Board and its constituent boards of education was:

How to grapple with the problems of explosive growth, capital shortage, a growing stock of portable classrooms, a growing stock of obsolete schools, while maintaining and advancing educational standards and meeting the intense pressures of fundamental social change in a cosmopolitan population.

To meet this challenge the school board established during 1965 The Metropolitan Toronto School Board, Study of Educational Facilities (SEF). During 1965 and early 1966 an Advisory Committee was set up, and the joint directors of SEF were appointed. On September 1, 1966,

# ORGANIZATION OF METRO & BOROUGH BOARDS OF EDUCATION

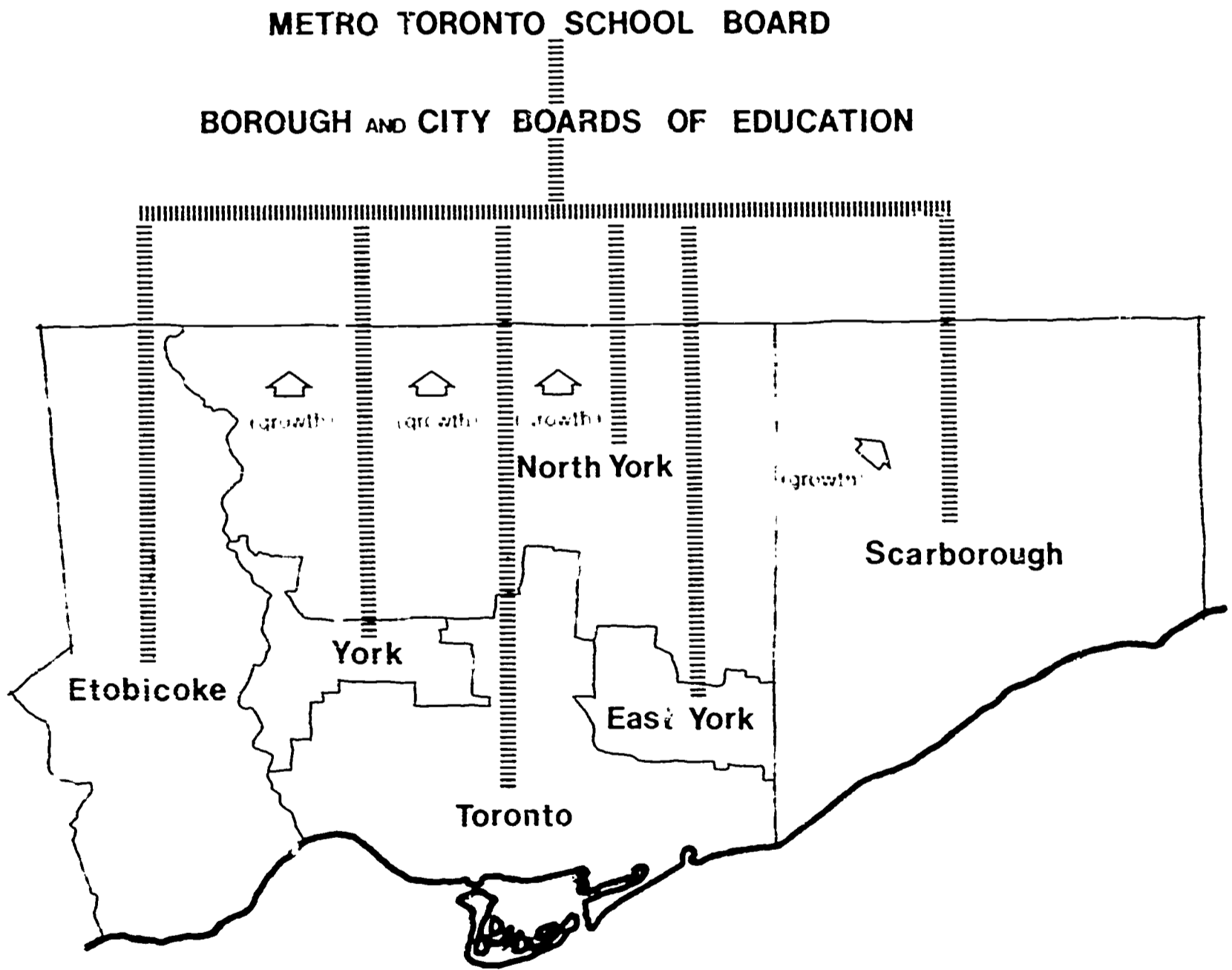

# METRO TORONTO SCHOOL BOARD & SEF OFFICE

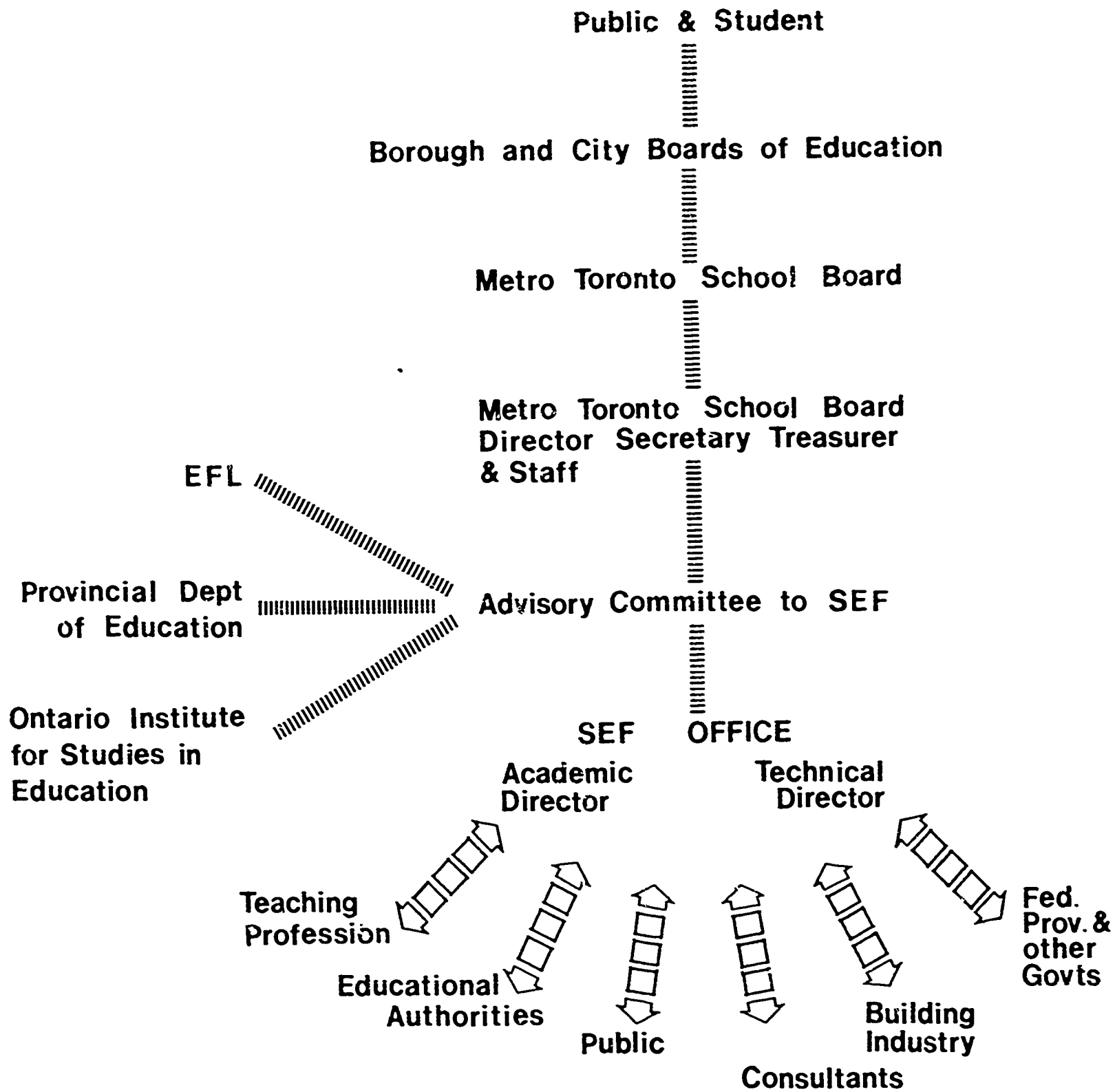

Mr. Hugh Vallery, the Academic Director and myself, as Technical Director, opened the SEF office. We were given an open mandate by the SEF Advisory Committee within the terms of reference set by the school board for the study--to solve the problem posed.

The terms of reference for the study were:

1. To develop systems and components specifically for school use.
2. To apply more effectively the principles of modular construction in achievement of greater flexibility of interior design.
3. To reduce the cost of school building construction to provide better value for expenditure in terms of function, initial cost, environment, and maintenance.
4. To analyze the problem of short-term accommodation, including an evaluation of the present use of portable classrooms, and a consideration of alternatives to meet short-term needs.
5. To analyze means of reducing the cost of school site acquisition, and school construction through the construction of joint occupancy structures.

To meet the terms of reference, a multi-disciplinary organization was established with educators, and architects, supported by a wide range of consultants.

During the three months prior to January 1, 1967, we organized the structure of the study and hired staff.

The studies were to embrace all aspects of the problem of providing school facilities, and were organized into three groups. The "E" series, or educational specifications which defined the user space and equipment requirements for elementary, intermediate, and senior school, comprising the Metro Toronto School system. The "T" series, or technical studies which would include the development of a permanent building system for schools, the study of mixed use, temporary buildings, and the development of a relocatable school building system. The "A" series, or administrative studies which would analyze all procedures involved in the development of a school project in Toronto.

ORGANIZATION OF SEF OFFICE

	<b>Academic Director</b>		<b>Technical Director</b>
	<b>Executive Officer</b>		<b>Senior Technical Research</b>
<b>50</b>	<b>Academic Research</b>	<b>Secretariate</b>	<b>Technical Research</b>
<b>Education Committees</b>			<b>MTSB Coordinator of Construction Programs</b>
<b>400 Members</b>			<b>Consultants</b>
			<b>Structural Engineer</b>
			<b>Mechanical Engineer</b>
			<b>Electrical Engineer</b>
			<b>Specification Writing</b>
			<b>Construction Management</b>
			<b>Industrial Designer</b>
			<b>Programmers</b>
			<b>Graphic Designer</b>
			<b>Real Estate</b>
			<b>Quantity Surveyor</b>
			<b>Sub-trade skills</b>
			<b>Manufacturing skills</b>
			<b>Film</b>

Publications:

The following publications are available from SEF or their publishers.

Available from the Ryerson Press, Toronto:

E.1: Educational Specifications and User Requirements for Elementary (K-6) Schools - Price: \$10.00

E.2: Educational Specifications and User Requirements for Intermediate Schools - Price: \$10.00

Available from Ryerson Press by Fall, 1970 and which may be ordered now:

E.3: Educational Specifications and User Requirements for Secondary Schools - The price will probably be \$10.00

Available from the SEF offices at 49 Jackes Avenue, Toronto 290:

T.1: Introduction to the First SEF Building System - Price: \$10.00

T.2: Specifications for the First SEF Building System - Price \$15.00

Bidding Sheets for the First SEF Building System - Price \$15.00

T.7: Sub-System Proposals for the First SEF Building System - Price \$10.00  
Will be available January, 1970 and shows a majority of the sub-systems bid to SEF.

In preparation, publication date and price not available:

T.3: Building Height, Land Use and Mixed Usage

T.4: Relocatable School Facilities

E.4: The Function of the School in the Community

A.1: Procedures for School Building Project Development in Metropolitan Toronto

Together, these publications will give a comprehensive and integrated proposal for the provision of school facilities in Metropolitan Toronto or any other large urban area.



In addition, by Summer, 1970, there will be available, probably on a rental basis, a 20 to 25 minute film on the interrelationship between the individual and the built environment. The film will show how flexible buildings might contribute to a broad upswing in our society's collective and individual creativity.

### The First SEF Building System<sup>1</sup>

I have attempted to illustrate the great breadth of study we have attempted at SEF, and will now restrict my remarks to consideration of the organization and development of the First SEF Building System.

At an early stage in the organization planning for the SEF building project, I became aware of the fact that it would be necessary to abandon normal sequential programming and seek many shortcuts if the work were to be brought to the stage of a workable building system by the end of August, 1969.

As a consequence, the essence of the SEF program has been, what has come to be known as "Fast Track" programming.

In making the presentation today, I will have to give you the data sequentially - you should keep in mind that the majority of the functions identified were stacked in a complex that ultimately involved the services of from 3,000 to 5,000 people immediately prior to bid closing.

### The Choice of an Approach

There were three choices of approach to meet the Board's terms of reference:

1. Use traditional design, general contractor lump-sum bid technique for the program, with perhaps some bulk ordering.

---

<sup>1</sup>See Appendix 1.

# EVOLUTION OF THE FIRST SEF BUILDING SYSTEM

## Problem Objectives

## Architectural Solution

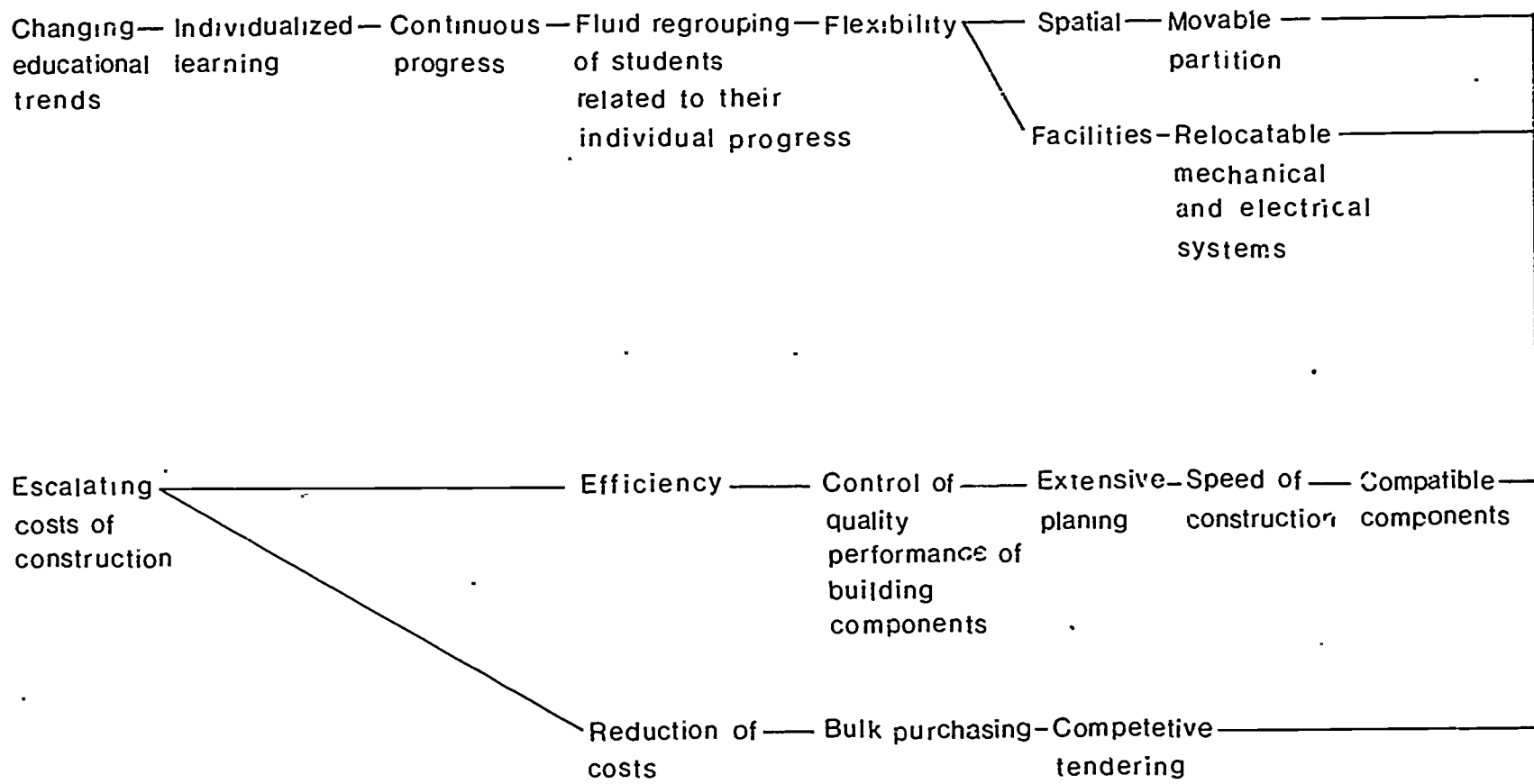

The First SEF Building System.

2. Develop a closed building system like CLASP or SCSD.  
(CLASP, Consortium of Local Authorities Special Program in use in Britain. SCSD, School Construction Systems Development applied in Southern California.)
3. Develop an open building system.

The use of the traditional design and lump-sum bid method was rejected on the grounds that the Board was already building large numbers of schools by this method, and it had been the Board's decision in its terms of reference to SEF to seek a more economical method of building while raising quality.

The choice of a closed systems approach offered two alternatives:

- a. For SEF to design the required building system in a completely prescriptive manner as had been characteristic of the British and most other European school building systems, and have industry bid against SEF system designs and specifications.
- b. For SEF to prepare a performance specification for prescribed sub-systems, and require the bidders to bid in closed teams for all sub-systems, thereby having a lead sub-system contractor. Usually, the structural sub-system contractor acts as co-ordinator for the group. The SCSD and RAS systems are examples of this approach.

The first closed system approach, that based on an SEF designed system, was rejected on the basis that it would have been necessary to establish at SEF a large technical bureaucracy. The system designed by this office would have been limited in its concept and quality by the skill of the SEF design team. It would have almost inevitably had a bias toward architectural considerations and weakness from a service engineering and industrial process viewpoint. Most British school building systems have been characterized by strong emphasis on the building shell, and relative weakness from the mechanical and electrical engineering standpoint. These same systems also tend to impose a strong architectural vernacular on the resulting building design. This latter point was diametrically opposed to my view of future building design, which holds that the user must be the environmentalist and

the responsibility for creating an environment to fit with his needs, while the architect is a resource who can set a framework for the user to operate within.

I recommended rejection of the second form of closed systems approach on the grounds that the owner would not get the best possible product. Also, that the failure of a system leading contractor would make substitution of another contractor impossible due to highly specific interfacing between sub-system contractors. It also appeared to me that in a system comprising 14 sub-systems as in the case of the SEF system, the chances of getting all of the best sub-system proposals in a single building system were extremely small.

I chose the open system approach<sup>2</sup> for three primary reasons:

1. That it would ensure, if an appropriate bidding method could be evolved, that the owner would get the best available system at a competitive price.
2. That the method could tap the full resources of skill in the building industry in an integrated manner.
3. That if the concept could be carried through to practical realization, it could help to move the Canadian, and consequently, North American building industries ahead very rapidly.

Building industrialization in a closed system form has been well established in the industrialized countries of Europe for up to 25 years. I felt in seeking an open systems approach to the School Board's building needs, it would be possible for the Canadian and North American building industries to leap frog this closed system phase, and move into a competitive export position with open systems.

---

<sup>2</sup>See Appendix 2.

It seemed also most important from a long-term national economic viewpoint that every effort be made to ensure that Canada got a fair share of the future massive international building market. The mode of the country's entry into industrialized building was critical in seeking that future. I felt that with SEF being the first Canadian program, among the largest in North America, and the most complex, that its effect on the Canadian and North American building industries would be disproportionately stronger than its relative dollar value would suggest.

The disadvantages of choosing the open systems approach were:

1. That it has never been successfully achieved in construction history.
2. That the approach involved extremely complex problems of coordination, quality control, and programming.
3. It cut across the entire established structure of the building industry and its working methods.
4. It was very costly to bid, although all costs could be recovered through independent marketing.
5. There was almost no means of predicting architectural quality, and extreme difficulty in imposing architectural control.
6. There could be serious conflict with the Code authorities.

Testing the Chosen Approach on the Building Industry and Preparing to Apply It.

The Advisory Committee to SEF approved my recommendation to attempt the open systems approach early in 1967.

SEF then spent several months reviewing the concept with associations, meetings, and individuals from the building industry to establish an acceptable attitude. During 1967, 120 major meetings were held. In addition, meetings were also held with groups of architects and engineers to determine those aspects of the built school environment which should be described in the performance specifications for the system. These meetings covering every interest and aspect of the

building industry, were the basis of the success of the project. Through a process, which often started with caution or cynicism, and mellowed to frankness, a means was created to join the capabilities of the industry to the needs of the school board. It was a wholly human process of establishing credibility, and constitutes the essence of the systems approach to building, for it should be remembered that the problems which beset the North American building industry, and consequently our own, are 85% human and 15% technical.

Also during this period, the 5'-0" x 5'-0" planning grid<sup>3</sup> for the system was selected, and tested against a rapid general review of probable spatial requirements for the three levels of schools to which the system was to be applied. The concern was to ensure that the required areas for enclosed spaces emerging from the educational study could be economically planned. It was found that the dimensional aspects of the educational requirements could be frozen by the spring of 1967, whereas the complete educational user requirements study would need until the spring of 1970 to reach completion. As a result the following basic dimensional criteria were established for the system.

1. A 5'-0" x 5'-0" planning grid divisible into two equal parts in either direction.
2. Primary structural spans of 10'-0", 15'-0", 20'-0", 25'-0", and 30'-0".
3. Secondary structural spans of 5'-0" to 65'-0" in 5'-0" increments. Both of these selections of spans are available for floors and roofs, with floors having a standard universal live load capacity of 100 lbs. per square foot throughout.
4. A standard roof and floor sandwich thickness from ceiling plane to floor plane of 4'0".

---

<sup>3</sup>See Appendix 3.

### REQUIRED DIMENSIONS

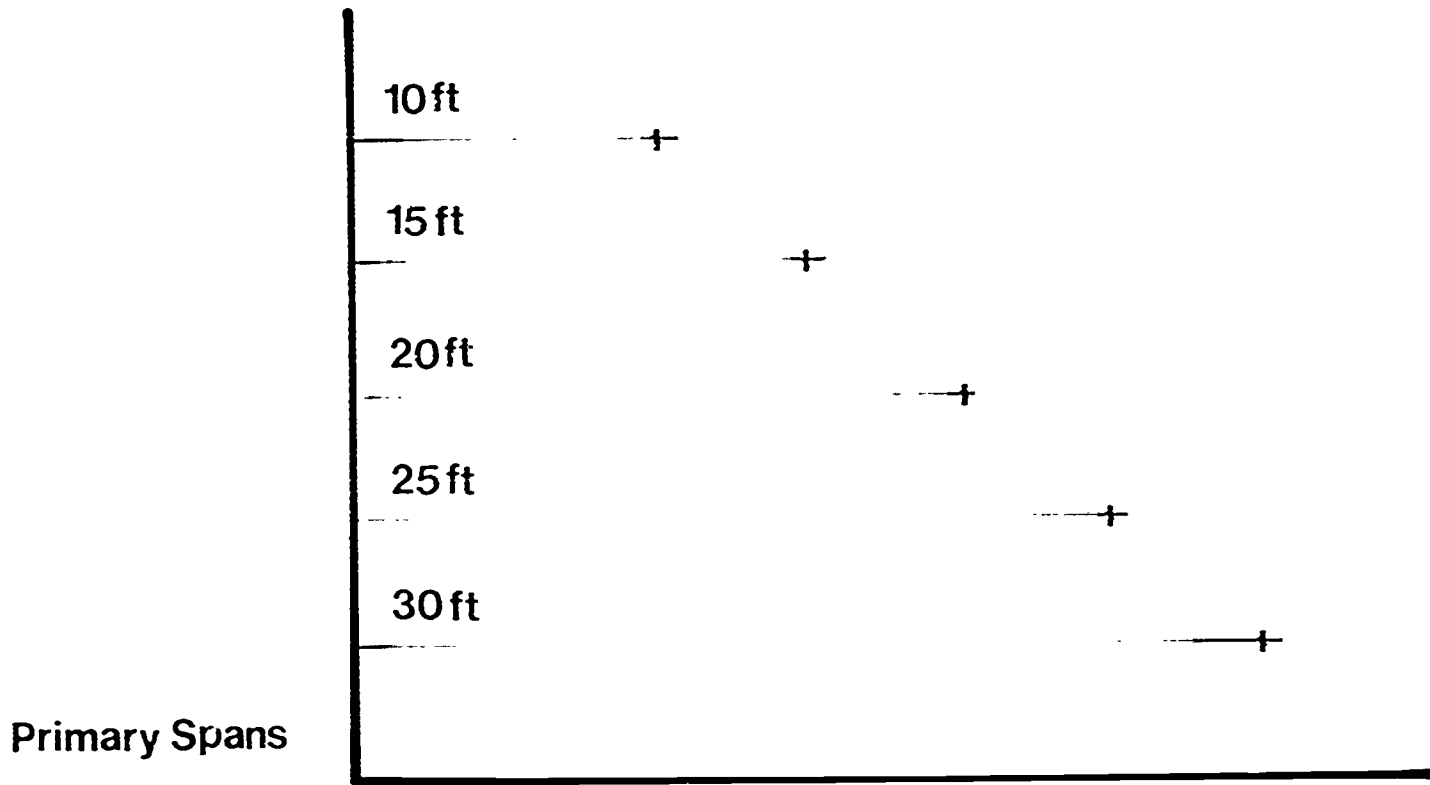

Secondary Spans 5, 10, 15, 20, 25, 30, 35, 45, 50, 60, 65 feet

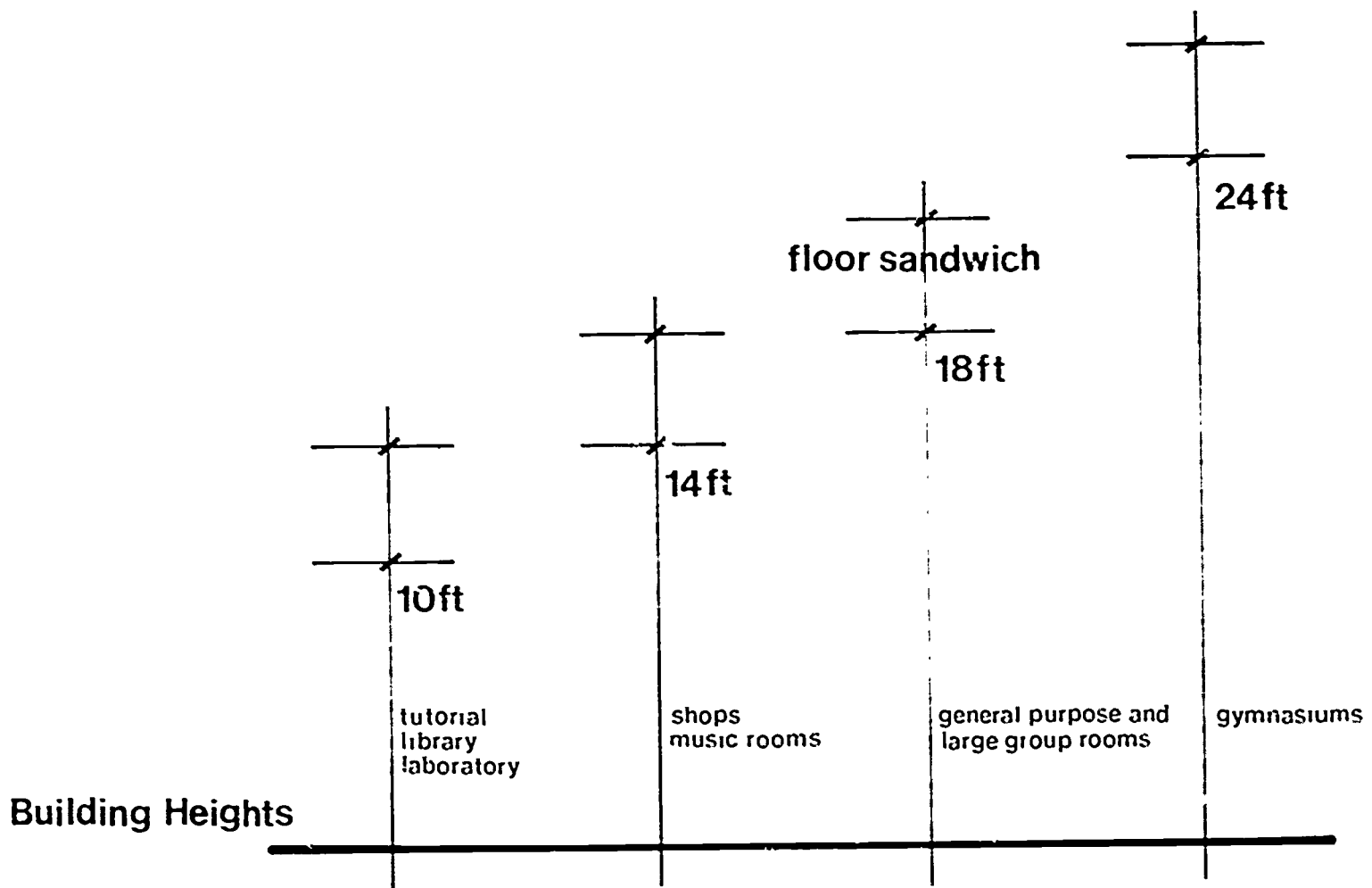

FLOOR SANDWICH

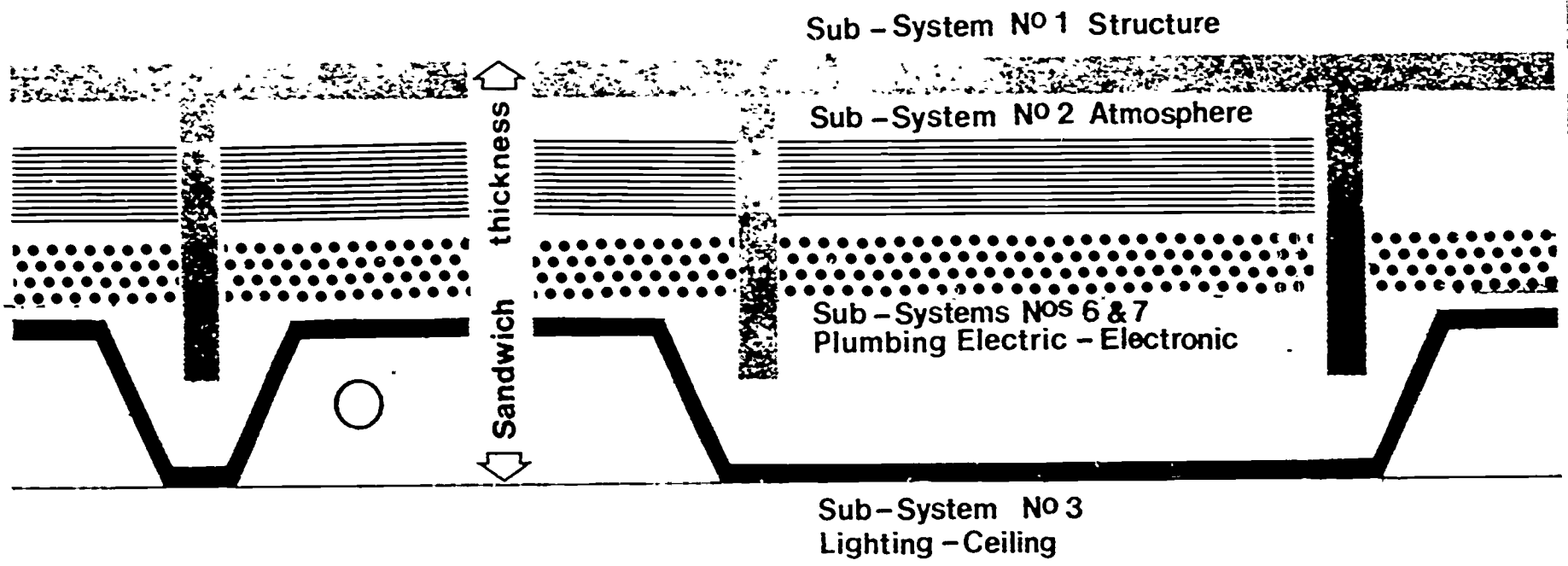



5. A capability to construct buildings upto five storeys in height, that is having four suspended floors. This height is the division between one and two hour construction for this class of building under the National Building Code.
6. Having a vertical module of 1'-0" with preferred clear floor to ceiling heights of 10'0", 14'0", 18'0" and 24'0".
7. An elimination of all cantilevers; sloping walls, roofs and other planes; and non rectangular based plan forms, and interior layouts.
8. The establishment of a convention for tolerances and interfaces.

Also determined at this time was the sub-system composition of the proposed building system. It was decided to seek as near 100 per cent systemization as practical. The final system is near 90 per cent if general contractors' fees are omitted.

Also, during this period, a detailed review of the literature of the technological aspects of the built environment was undertaken, with particular emphasis on lighting, the acoustic climate, the artificial climate, tactile considerations, and the flexibility of space.

From this complex of studies, meetings, and consultations, the following requirements emerged.

1. Flexibility:-- It must be possible to rearrange the space dividers, all services and caseworks easily and economically without extensive building work.
2. Open ended services:-- It must be possible to rearrange the services to change the servicing characteristics to specific areas, to add to or subtract from existing services, and to replace services without damaging other work.
3. Extensions:-- It must be possible to make additions to schools, both horizontally and vertically, within a consistent framework of service technique.

**THE BUILDING PROCESS**

- Expression of need to build
- Appointment of consulting architect and team

Owner approval

- The user requirements
- Building program
- Planning
- Zoning

Owner approval

- Preliminary design
- Cost plan
- Outline job planning
- Appointment of management contractor

Owner approval

Traditional Building Process

SEF - Systems Building Process

- Financing
- Final design specifications working drawings
- Final cost plan
- Final job planning
- Statutory approvals

Owner approval

- Construction
- Project management
- Project completion

Owner approval

- Project take over by owner
- Operation
- Review building process
- Feedback

Owner approval

4. Building Design:-- It must be possible to design any required school building with the system, giving the maximum possible design freedom to the project architect.
5. Quality Improvement:-- The building system should improve the quality of school building in material performance and maintenance.
6. Economy:-- The building system should restrain the rate of increase of the cost of building, and if possible produce actual cost savings.
7. Cyclical Renewal:-- Through the use of a properly structured open building system it should be possible to cyclically renew sub-system without the need for extensive renovations to school buildings.
8. The User and The Built Environment:-- The building system should encourage users to explore their creative skill in moulding their building environment to suit their educational, emotional and spiritual needs.

Having determined the nature of the required building system's performance and that it should be open; that it should be competitively tendered, meet all existing building codes, and achieve time and economies, an appropriate systems approach was devised.

#### THE FIRST SEF BUILDING SYSTEM

The challenge of the program was clear; to devise the first open building system in history.

To do this, I decided that it would not suffice to develop one appropriate bidding technique, but that it would be vital to "sell" the concept to all interests in the building industry.

As it was necessary to deal with all interests in the building industry, I felt that a very small tight-knit group at SEF might be more successful than a large technical staff in handling the numerous, overlapping, and original problems posed by the project.

# BUILDING SECTIONS

SEF SYSTEM MUST BE ADAPTABLE  
TO ALL SITES  
SOME REQUESTED SECTIONS

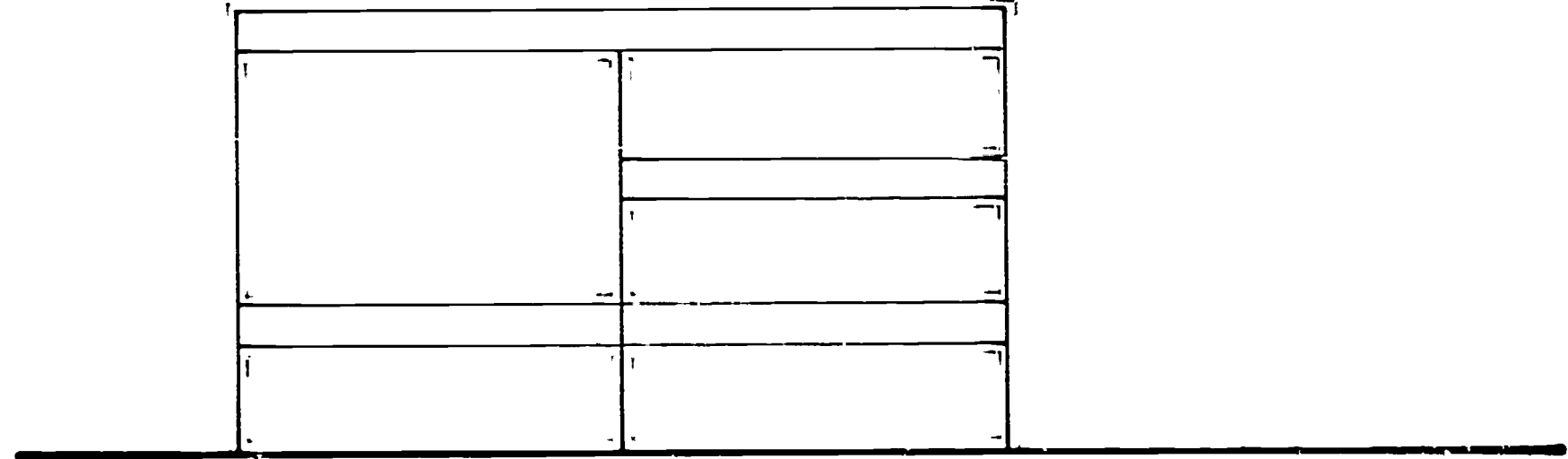
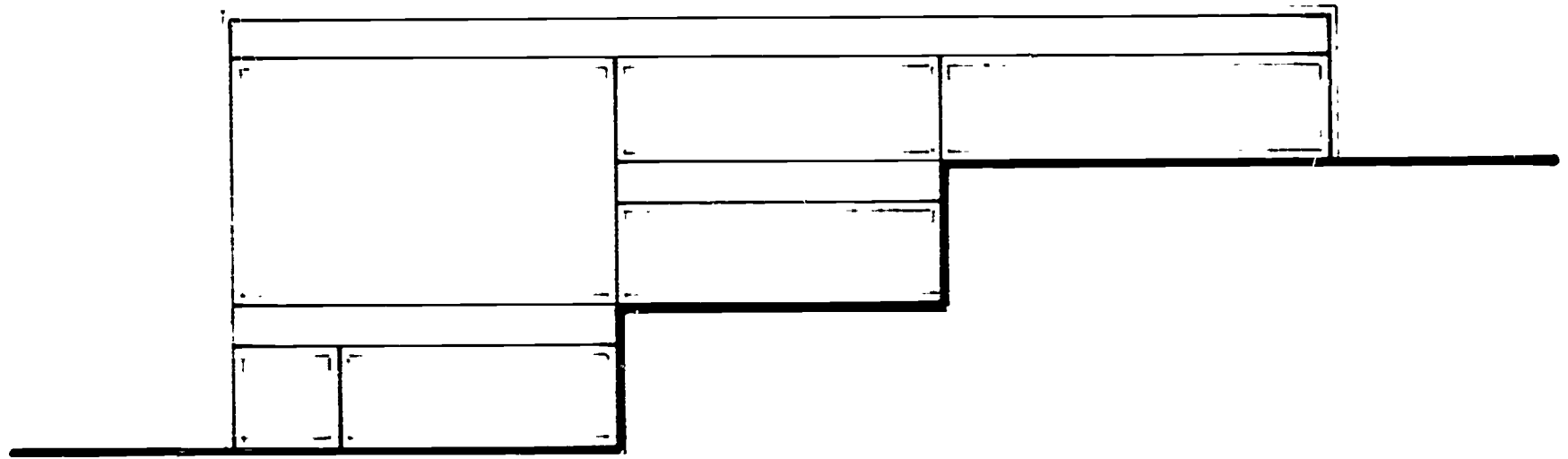
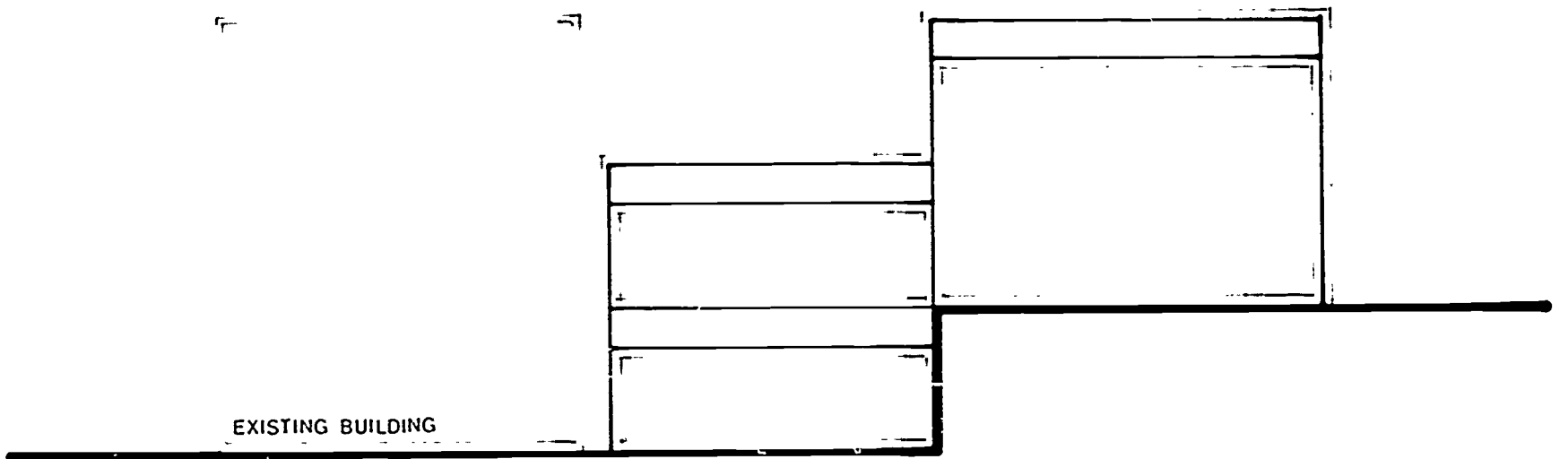

# CYCLICAL RENEWAL

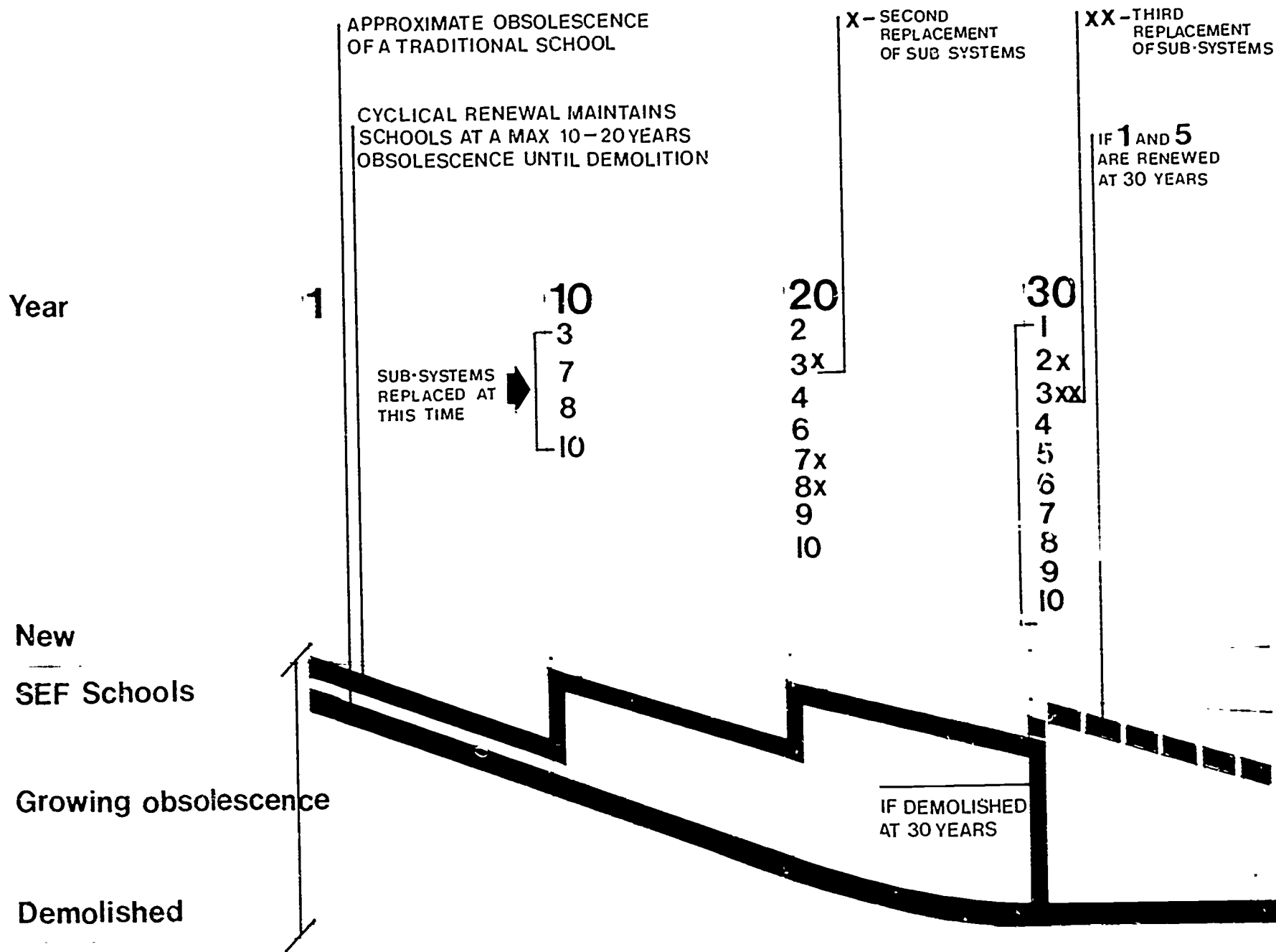

RENEWAL CYCLE

Initial Life Span

PERMANENT	Structure 1 Vertical Skin 5 Stairs	30-60 Years
	RENEWABLE	

Developed Life Span

PERMANENT	Spatial Equipment	Structure 1 Vertical Skin 5 Roofing 9 Siteworks Subgrade Services Foundations Stairs	30-60 Years
	RENEWABLE	Living Equipment	

OPEN ENDED  
BUILDING EVOLUTION

Year

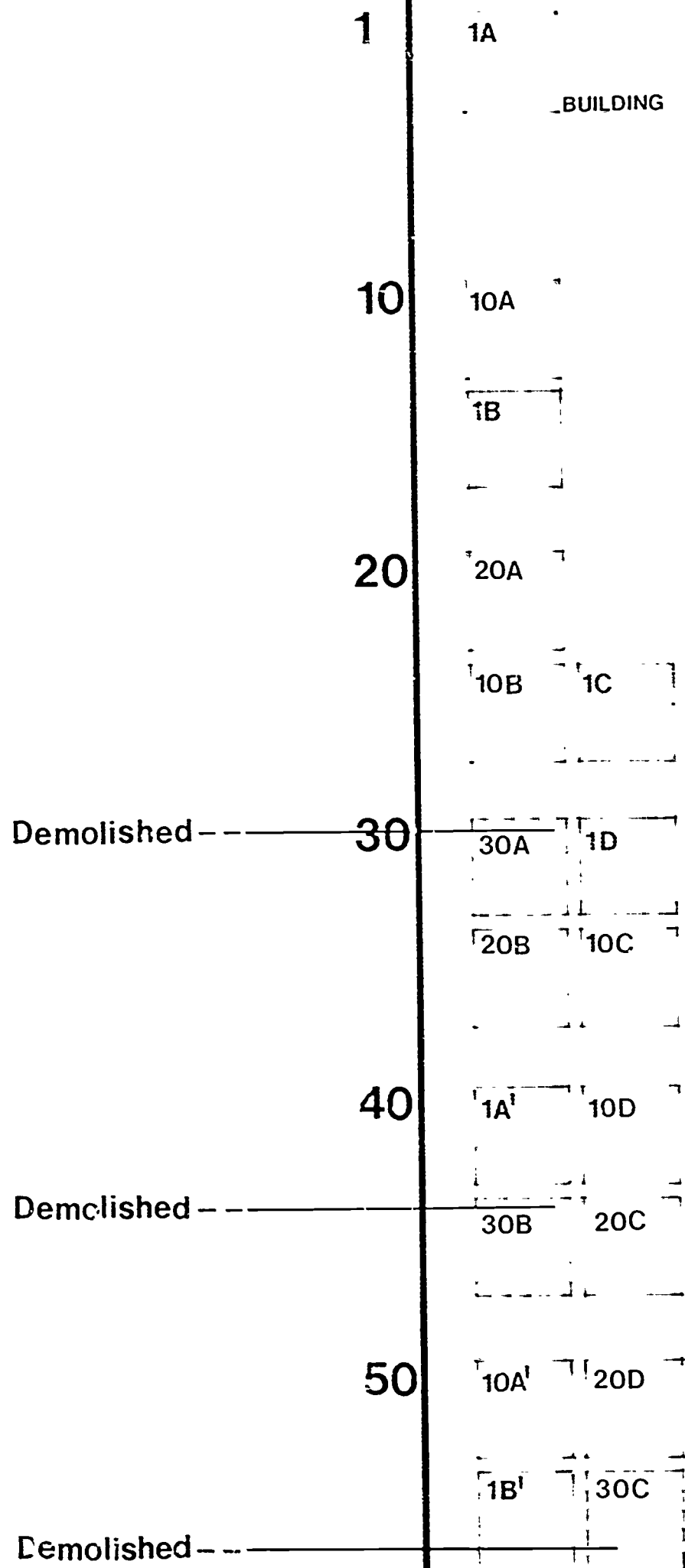

SUB-SYSTEM DIVISION

<p>1</p> <p>Structure</p>	<p>2</p> <p>Atmosphere</p>	<p>3</p> <p>Lighting-Ceiling</p>	<p>4</p> <p>Interior Space Division</p>	<p>5</p> <p>Vertical Skin</p>
<p>6</p> <p>Plumbing</p>	<p>7</p> <p>Electric-Electronic</p>	<p>8a</p> <p>Caseworks</p> <p>b</p> <p>Seating</p> <p>c</p> <p>Standard Furniture</p>	<p>9</p> <p>Roofing</p>	<p>10a</p> <p>Carpet</p> <p>b</p> <p>Gym Floors</p> <p>c</p> <p>Hardware</p>



FLEXIBILITY

- Sub-system 1 Structure
- 2 Atmosphere (Relocatable Air Conditioning)
- 3 Lighting-Ceiling (Relocatable Components)
- 4 Interior Space Divisions (Demountable)
- 5 Vertical Skin
- 6 Plumbing
- 7 Electric-Electronic
- 8 Caseworks
- 9 Roofing
- 10 Interior Finishing

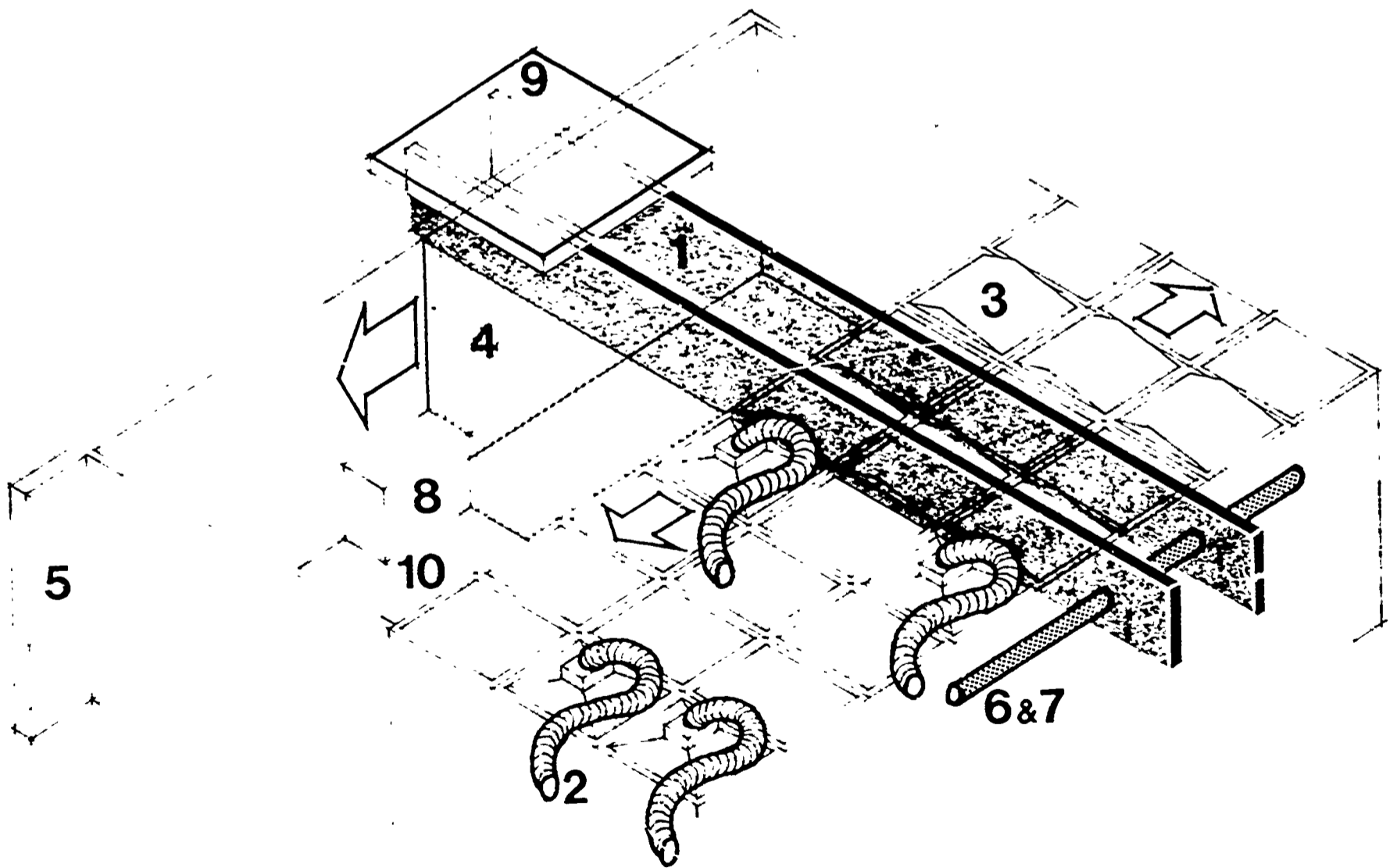

~~11.~~

A group of three people at SEF did all the work on the First SEF Building System supported by a group of consultants.

Mr. Peter Tirion, Mr. John Rankin and myself constituted the SEF group, assisted by Mr. G. Granek of G. Granek & Associates, Mechanical Engineers; Mr. R. Bergman of M.S. Yolles Associates Ltd., Structural Engineers; Mr. B. Rubin of Jack Chisvin & Associates, Electrical Engineers; Mr. R. Fernandez of Frost Fernandez Associates, Professional Specification Writers; Mr. F. Helyar, of Helyar, Vermeulen, Rae & Mauchan, Quantity Surveyors; Mr. H. Connor, of Woods Gordon, programming; Mr. W. Newton of Hugh Newton & Company, Graphics; Mr. M. Morgan of Mitchell Construction Co. (Canada), for construction consultation; Dr. Thomas Northwood of the National Research Council, for Acoustics; Mr. Z. Shah of the Canadian Standards Association, for testing techniques; Mr. A. Faux of Al Faux Associates Ltd., for industrial design (caseworks and seating); Dr. R. Blackwell, Ohio State University, for special lighting consultation; Mr. Singer, of Beckett Associates, Consulting Economists for the escalation index; and many others. A full list is available in the press release made public at the time of the designation of bidders.

My general management concept for the program was to use a process which might be called "conglomerate management", wherein there could be a near infinite number of "centres of decision" with only enough centrality of control to ensure movement of all effort to the project goal.

As a result of this process between 3,000 and 5,000 persons were involved in the preparation of the bid.

#### The Structure of the Building System

The intent was to structure the building with a number of sub-systems, which collectively would constitute physically, as near as 100 per cent of the required building work, where a building system was a set of building parts which had been conceived and manufactured to assemble without adjustment or waste.

The First SEF Building System comprised 10 sub-systems, two of which have been further sub-divided. Where a sub-system is an identifiable, complete, designed, physically integrated, dimensionally co-ordinated, installed series of parts, which function as a unit without prescribed performance limits.<sup>4</sup>

The Sub-Systems are:-

Sub-System No. 1 - Structure: including floor, and roofdeck elements, secondary and primary spanning members, columns including baseplates, wind bracing and fire proofing, except where through interface negotiation other sub-systems serve the fireproofing function; special conditions such as expansion joints, changes in floor and roof levels, openings in floors and roofs, and provisions to accommodate and connect other related sub-systems, such as vertical skin, lighting-ceiling etc.etc.....

Sub-System No. 2 - Atmosphere: heating and cooling systems, consisting of equipment for converting energy into a usable form for heating and cooling with all accessories; heat exchangers, coils, pipes, pumps, radiators, convectors, unit heaters, and electric heaters with power wiring and conduits; air distribution system consisting of fans, filters, ductwork, supply air outlets, return and exhaust air inlets, all automatic temperature, humidity and other controls; electric motors with starters and control wiring and/or pneumatic systems; vibration isolation and sound control; related drainage system; all insulation and covering; all oil tanks, and all pipe or cable connections to public utilities related to the atmosphere sub-system.

Sub-System No. 3 - Lighting/Ceiling: all lighting fixtures and connections, acoustic insulation, ceilings both coffered and flush, fireproofing where required, provision for restraining the Interior Space Division sub-system, provision for the Electric-Electronic sub-system, and the provision to interface with other sub-systems.

---

<sup>4</sup>SEF Document T-1: Introduction to the First SEF Building System  
Page A.6 - Appendix - Terminology.

Sub-System No. 4 - Interior Space Division: all elements which provide vertical separation of space from floor to ceiling inside the building, including doors, panels, glass and glazing, accessory writing and tack-board panels attached directly to partitions, baseboard, trim, supply and installation of hardware for operable partitions; installation only of hardware for other partitions.

Sub-System No. 5 - Vertical Skin: walls from first floor upwards; including all walls designed to separate the controlled from the natural climate environment; all framing, panels, insulation, vapor barriers, waterproofing membranes, caulking, sealing, weatherproof coatings, weatherproof strippings, windows, doors and screens, including all transoms, sidelights, glazing, louvres, fly screens, surrounds, sills, lintels, hardware which forms part of proprietary equipment, and an allowance for the fixing of finished hardware anchors, bolts, bare plates, bearing plates; all required fixing details to secure sub-system No. 5 (vertical skin) to sub-system No. 1 (structure) and provision to integrate sub-system No. 5, with sub-system No. 9 (roofing).

Sub-System No. 6 - Plumbing: all plumbing fixtures with trim, supply drainage and vent piping with capped connections, within wall, ceiling and floor cavities, together with all other piped services so located including siamese connections. All piped services below grade slabs, and all service connections to piped public utilities. Hot and cold water supply systems with related equipment including water heaters, circulating pumps, motors and controls, with all related insulation and wiring. All W.C. partitions and shower enclosures, fire hose cabinets and washroom accessories. All washroom, and janitor's room wall, floor and ceiling finishes, including light fixtures, ventilation grills, access panels and other accessories to complete the room finishes.

Sub-System No. 7 - Electric/Electronic: distribution, including lighting panels and branch circuit connections; communication systems including fire alarm call systems, detection, P.A. systems, telephone, provision for television and auditorium equipment, local broadcast system, supervisory and surveillance systems.

Sub-System No. 8 - Caseworks and Furniture: sub-system No. 8A  
Caseworks; cupboards, counters, laboratory benches, tables, lockers, library shelving, check-out counters, and all other forms of storage units. Relocatable screens, writing and tack surfaces, and all horizontal and included student work surfaces.

Sub-System No. 8B - seating: fixed and adjustable chairs, lounge chairs, stools, benches and cushions.

Sub-System No. 8C - standard furniture: executive, secretarial and office desks, filing cabinets and general office non-mechanical equipment accessories.

Sub-System No. 9 - Roofing: roof covering, vapor barrier, all roof insulation, including below rooftop atmosphere machines, flashings, cant strips, gravel stops, expansion joints, venting features, finish at eaves, fascia, caulking, sealants, roof hatches, skylights and all other features necessary to provide a continuous weatherproof, vapor-proof, waterproof and consistently insulated covering to all horizontal exposed surfaces, and all vertical exposed surfaces within a roof system 4'-0" or less finished height. This sub-system is also responsible for the provision of a weatherproof, waterproof, vapor-proof insulated and condensation resistant connection between sub-system No. 5 (vertical skin) and sub-system No. 9 (this sub-system).

Sub-System No. 10 - Interior Finish

Sub-System No. 10A - Carpet

Sub-System No. 10B - Gymnasium Flooring

Sub-System No. 10C - Finishing Hardware

Sub-System No. 10D - Blinds and Drapes (To be added)

Non-System Work: includes all woods, required to complete a building which have not been covered by sub-systems.

The principal items of non-system work are demolitions, foundations, and basement construction; foundation walls and underpriming;

suspended first floor slabs, including topping and supporting beams, and columns; rough carpentry, greenhouses, stairs (were included in structure but were not bid due to large number of variables and small quantities) steps, ladders and catwalks, including landings and hand-rails; all balustrades and guardrails; elevators, kitchen equipment, refrigerators and walk-in freezers; garbage disposal equipment and incinerators; fire extinguishers, and sprinkler systems; power systems including controls; power electrical distribution, generators and switchgear; all mechanized educational equipment, all unusual finishes including murals, pictures, sculpture, cork and special acoustical insulation or isolation, resilient, terrazzo and hardened concrete flooring, auditorium curtains, stage, athletic and playground equipment, all site works, and all indirect job management expenses.

Having determined the form of system favoured for the program, it was necessary to determine the size of order which should be offered to industry.

Two hundred and seventy companies and sub-contractors were contacted by letter and questionnaire. About half replied. The majority of omissions were large corporations who gave the program and the school board a polite corporate brush-off. Medium size and smaller companies together with sub-contractors responded strongly. Minimum required orders by sub-system varied from \$10,000.00 to \$20,000,000.00! Finally a minimum guaranteed order of 1 million square feet gross of schools was decided upon by the school board over a two year period, September 1969 - 1971, with a maximum order of 2 million square feet gross. In order to call sub-system tenders the Metropolitan Toronto School Board had to obtain Provincial Legislative changes to its enabling legislation. The board also negotiated a common approval for the schools comprising the SEF program with the Ontario Municipal Board.

During this period the Metro Toronto School Board invited the Borough Boards of Education to indicate their support for the SEF program by assigning schools to meet the volume of the minimum guaranteed order.

To this date 33 projects have been attached to the program. They are:

- 1 Senior Public School addition - the SEF Partial Building  
to test the technical aspects of the designated system (2 storey)
- 23 Public Schools
- 4 Senior public schools (upto 4 storey)
- 3 Junior High Schools
- 1 Senior Public School in a mixed use residential, social,  
commercial project
- 1 Education Centre (office building - 4 storey)

Additional projects which may be added could include a comprehensive high school.

The commitment by the City and Borough Boards of Education of 33 projects to the program was strong evidence of the Metropolitan Board's intent to proceed with the program.

A great difficulty with projects like SEF is to convince the potential bidders that the Owners do intend to carry through the program to its conclusion. It is a question of credibility and trust. The Trustees, and officials of the Metro, City and Borough School Boards have ensured the financial and technical success of SEF through their strong and consistently sustained support for the project.

As a result of this demonstration of confidence and solidarity, the 36 bidders for the first 10 sub-systems invested an estimated total of \$2.6 million in their bids.

In every sense SEF has been a collective project.

#### The Specific Requirements of the Program

To bring the program into being a series of interrelated constraints were established. They were:

1. An overall time program including program scope definition.
2. A program budget, and escalation procedure.

ORGANIZATION OF THE FIRST SEF BUILDING SYSTEM PROGRAM

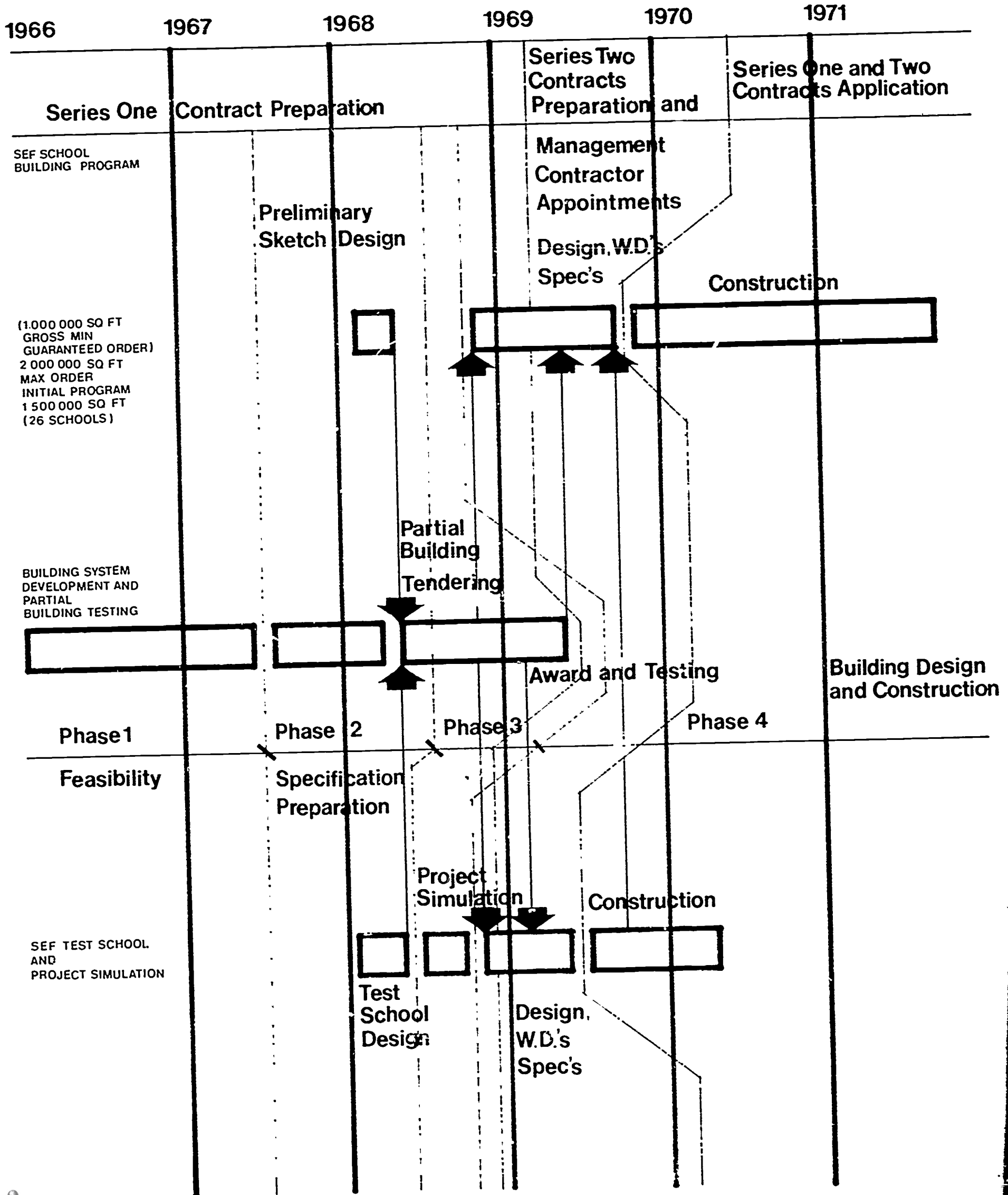



SCHEDULE OF RATES  
FIRST SEF BUILDING SYSTEM

	Gross Price Per Sq.Ft. Oct. 1967 Average
<u>Sub-Systems</u>	<u>\$</u>
SUB-SYSTEM 1, STRUCTURE	2.30
SUB-SYSTEM 2, ATMOSPHERE	3.14
SUB-SYSTEM 3, LIGHTING-CEILING	1.12
SUB-SYSTEM 4, INTERIOR SPACE DIVISION	2.39
SUB-SYSTEM 5, VERTICAL SKIN	2.11
SUB-SYSTEM 6, PLUMBING	1.37
SUB-SYSTEM 7, ELECTRIC-ELECTRONIC	.75
SUB-SYSTEM 8, CASEWORK AND FURNITURE	.87
SUB-SYSTEM 9, ROOFING	.87
SUB-SYSTEM 10, INTERIOR FINISHING	.88
NON-SYSTEMS	5.14
SUMMARY OF GROSS COST PER SQUARE FOOT FOR ELEMENTARY SCHOOL CONSTRUCTION OCTOBER 1967 AVERAGE	
TOTAL	21.54
BUILDING	20.85
SITE WORKS	.69

3. A bidding and interfacing procedure. Sub-system bidder prequalification.
4. A quality control procedure, including performance specifications, dimensional coordination, sub-system coordination, continuity of professional liability.
1. An Overall Time Program: Early in 1966 a program calendar was established for the project based only on working days. Starting in 1967 the entire program was structured using the precedence method of programming. As time has passed, the original program has been broadened to embrace ever increasing amounts of detail. SEF has stayed precisely on its time schedule until the recent series of construction industry lockouts and strikes which crippled all work in the Toronto region between May and September 1969. Late in 1967 and early 1968, 28 firms of architects were retained to prepare sketch designs for the SEF schools, using only dimensional criteria. These are included in appendices B and C of SEF T-1.
2. Program Budget: Also during 1967 the project budget was set. It is the practise of the Metro Toronto School Board to set a cost ceiling for its school construction. To arrive at a realistic price, six public schools which had been built between 1965 and 1967, and having as many of the SEF user requirement characteristics as possible, were cost analysed in detail. A cost of \$20.85 per square foot gross including foundations emerged. This amount was frozen as the project budget to apply on 7th January, 1969 when sub-system tenders would be received. It should be noted that the establishment of a building system budget broken down by sub-systems, and interfaced with the sub-system performance specifications is an essential part of a building system tender call.

MANDATORY INTERFACE

---

1	2 3 4 5 6 7 9	
2	1 3 4 5 6 7 9	
3	1 2 4 5 6 7	
4	1 2 3 5 6 7 10a 10b 10c (not required)	
5	1 2 3 4 6 7 9 10a 10b 10c (not required)	
6	1 2 3 4 5 8a 9	
7	1 2 3 4 5 8a 10a	
8a	4 5 6 7 10a	Sub-systems 8a and 8b will be required to interface with the sub-systems noted and <u>not</u> vice versa
8b	10a	
9	1 2 5 6	
10a	4 5 7 8a 8b	
10b	4 5	

---

This budget was broken down into a schedule of sub-system allowances as follows:

	<u>Gross Price per Sq.Ft. Gross</u>
Sub-system No. 1 - Structure	2.30
Sub-system No. 2 - Atmosphere	3.14
Sub-system No. 3 - Lighting-Ceiling	1.42
Sub-system No. 4 - Interior Space Division	2.39
Sub-system No. 5 - Vertical Skin	2.11
Sub-system No. 6 - Plumbing	1.37
Sub-system No. 7 - Electric/Electronic	.75
Sub-system No. 8 - Caseworks	.87
Sub-system No. 9 - Roofing	.87
Sub-system No. 10 - Interior finishes	.88
Non-systems work	5.44
<hr/>	
Total for building	20.85
Site works	.69
<hr/>	
Total	<u>21.54</u>

In order to obtain the most competitive prices possible, and to offset the extremely adverse effects of the anticipated expensive labour wage settlements in 1969 on the sub-system bidding, a comprehensive system of price escalation was set up. To our knowledge this is the first fully structured and industry approved cost escalation index to be established. The index is based on data provided specially by the Dominion Bureau of Statistics and was designed by SEF and its consulting economists, Beckett Associates of Toronto, to show material and site labour cost changes by sub-system, on a monthly basis, starting on 1st January, 1969.

OPEN SYSTEMS APPROACH

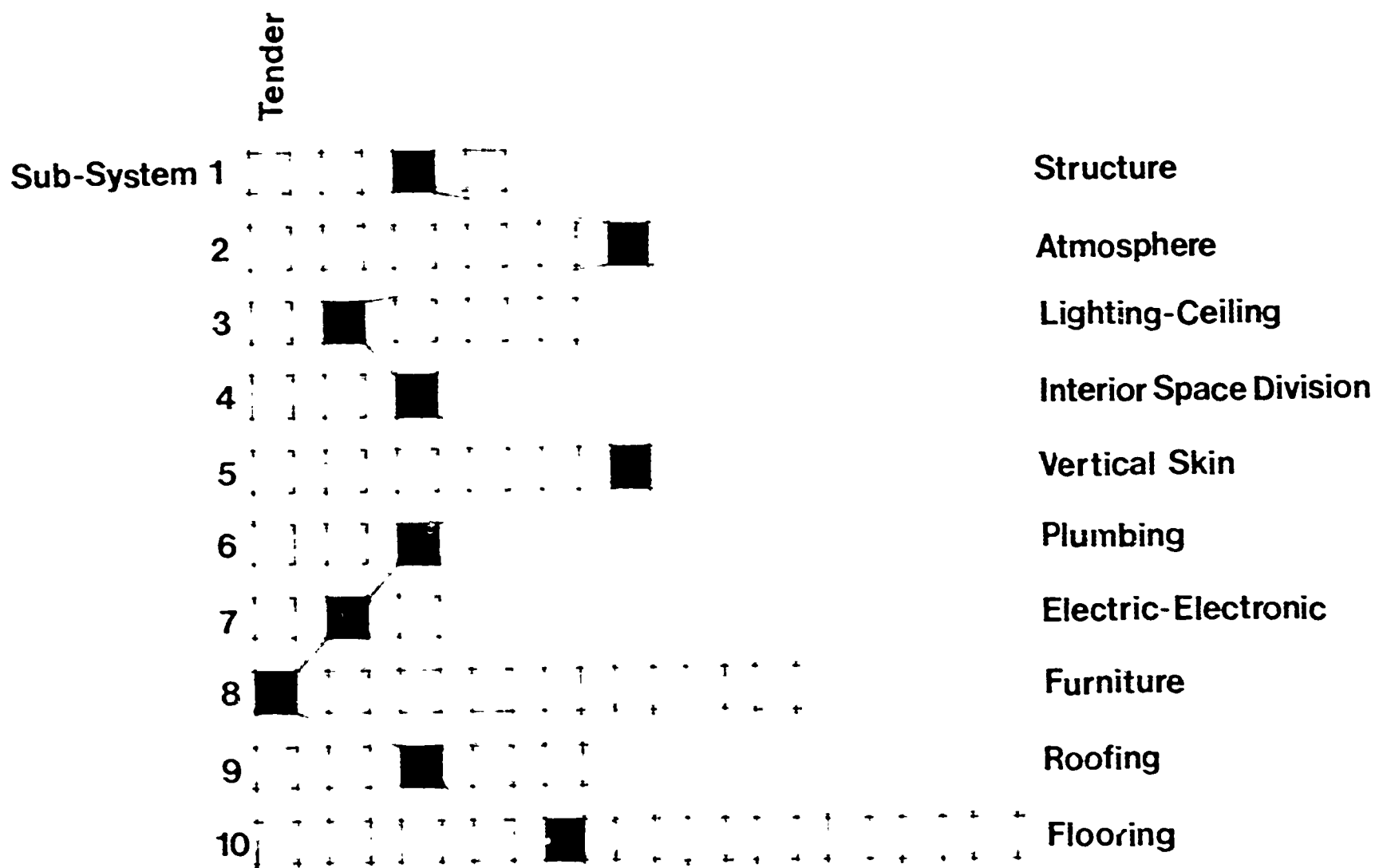

## PREQUALIFICATION OF SUB-SYSTEM CONTRACTOR

### Organization of Sub-system Tenderer

- Corporate Organization
- Financial Status
- Management
- Research Capability
- Consultants

### Production of Sub-System Tenderers

- Organization
- Capacity and Arrangements to Produce
- Install or Erect the sub-system

### Sub-System Tenderer Submits Tender Form

- Design Development
- Testing of Proto-Type
- Manufacture
- Supply
- Erection
- Installation
- Guarantee

## PREQUALIFICATION OF CONSTRUCTION MANAGER

- Financial Status
- Organization Skills
- Past Experience. References
- Staff Structure

3. Bidding procedure: The gross budget for the SEF program is \$41.7 million, or about 25% of the total Metropolitan Toronto School Board capital budget for the period 1969-71. Due to the risk involved in opening a program of this magnitude to public bidding it was decided to prequalify all bidders. The prequalification procedure examined the financial, productive and installation capacities of potential sub-system tenderers. Prequalification did not exclude consortiums, but rather ensured that they were in-fact adequately integrated. Of 60 bidding groups who sought prequalification, 48 were prequalified.

An interface bidding procedure was evolved where each bidder was required to submit his own price against at least two bidders in each mandatory interface for his sub-system.

A mandatory interface occurred where parts of one sub-system touched, passed through or influenced the performance of another in a finished building.

Each bidder reflected the degree of compatibility between his and mandatory interfaced systems by either bidding his base bid where no conflicts existed or adding to his price a penalty amount where interface problems would occur.

In adjudicating this bid SEF would award the contract to the 10 sub-system tenderers (one for each sub-system) offering the lowest collective price; after ensuring that all bids considered met the appropriate SEF sub-system performance specification.

4. Quality Control Procedures, comprised the following :

Performance Specifications: these were written for each sub-system. They set out what a sub-system had to do in the finished building, but not with what or how this performance was to be achieved. The specifications set out the tests (where such existed) which would be used to evaluate the proposals received. The bidders

were given complete freedom to design and develop their own responses to these performance specifications. This led to the direct tapping of a vast body of skill and experience in the manufacturing, supply and sub-contracting portions of the building industry largely locked out by the traditional design, lump-sum bid method job organisation, and often distorted by the common builder package deal approach.

**Dimensional Co-ordination:** mentioned elsewhere in this paper.

**Professional Sub-System Coordination:** bidders were required to use the services of an architect and engineer (of the appropriate skill) registered in the Province of Ontario to coordinate the interfacing of their bids.

In addition the interface contract, created by the industry facilitated the many problems of coordination between bidders.

It should be noted that under the SEF interface bidding system, interfacing bidders were free to move their mutual interface from that defined in the performance specifications to suit the realities of their plant, sub-system design or other mutually acceptable reason.

#### **Code and Standards**

In bidding the program all relevant codes and standards had to be met. We did enjoy very considerable cooperation from the Building Inspectorates, and the Fire Chiefs of the Metro region who reduced their numbers from 12 to 2 for our purposes. Similarly the Ontario Fire Marshal, Ontario Hydro, the Department of Education, C.S.A., and Underwriters Laboratories cooperated closely with us on the solution of many unique problems.



### The Bids

Thirty six sub-system bidders, offered 45 proposals on the first ten sub-systems bid. These excluded caseworks, seating, standard furniture, hardware and blinds. The ten sub-systems constituted the bulk of the building elements. Sub-system bidders were almost all partnerships of manufacturers and sub-contractors. In some cases involving more than two separate companies.

The 36 sub-system tenderers spent approximately \$2,600,000 on their bids, and spent up to 1 year preparing them. The official bidding period was 6 months. An immense number of meetings were carried out involving everything from aesthetics to inter-union jurisdictional differences. A remarkably small amount of difficulty arose from this process, which was characterized as I mentioned earlier, by hundreds of decision centres in an overall conglomerate management process. The degree of cooperation between companies in finalizing their designs and prices was reflected in the size of specific interface penalties.

Bid Evaluation: Bids were received in three forms.

1. As a schedule of unit prices for every component forming a sub-system. Priced on the basis of a single price if one or a thousand units were purchased - with the price conditioned by the bulk order details.  
The unit price schedule, parts and installation catalogues to form the basis of the contract between the successful sub-system contractors and the Metropolitan Toronto School Board.
2. As Tenderers' Evaluation Prices. These were the lump sum cost of applying a tenderer's sub-system to four nominated school designs. SEF provided the school designs to which the bidders were required to apply their systems without altering the building designs, using the rates in their unit price schedules. To these lump sum amounts bidders added their interface penalties. These prices were used to select the probable successful bidders.

**SUB-SYSTEM 1  
TENDERER'S EVALUATION PRICES**

Name of Sub-System Tenderer .....

Tenderers combined gross base evaluation price for the four nominated  
schools.....  
..... dollars.

**BIDDER'S EVALUATION PRICES BY CHOSEN INTERFACE**

Name of Interface Tenderer	Price
Re: Sub-System Nr. 2 ATMOSPHERE	Gross Base Evaluation Price
1. ....	
2. ....	
3. ....	
4. ....	
5. ....	
6. ....	

This was done by processing all bids through a computer, which considered just over one million price combinations. Revealing a 1.8% price spread on the low 30 total system bids, and 13,040 total building systems which met the SEF performance specifications. These systems ranged in value from a theoretically applied low of \$18.00 per square foot gross to \$26.61 per square foot gross. The least expensive nominated design was \$18.52 per square foot gross. The system price was set at \$19.10 per square foot gross or 8.39% below budget. The Roden Public School which was designed by SEF at \$18.52 per square foot was 11.10% below budget.

An analysis of the cost of building a school to meet the SEF performance specifications by traditional methods indicated a cost of \$26.00 per square foot. In other words the School Board against a budget of \$41.7 million, obtained \$52.00 million of value for \$38.2 million.

The technical quality of the bids designated by SEF is extremely high. Almost without exception the bidders who put the greatest amount of work in their bids, were the most competitive and won.

It is interesting to note that a senior authority on University construction in the Province of Ontario expressed the view that buildings constructed with the SEF system would be superior in quality to many new university buildings in the Province at considerably lower cost, without considering the long term economic benefits of the flexibility of the system.

Individual Project Construction. All buildings to be built under the SEF program will be built using construction managers, there will be no conventional general contractor. The managers, who are all contractors, will work as part of a design-build team for a professional fee. This cuts administration complexity, allows early starts on construction and work staging.

# DUAL CONTRACT PROCEDURE

SERIES ONE CONTRACT - SELECTION OF SUB-SYSTEM CONTRACTS

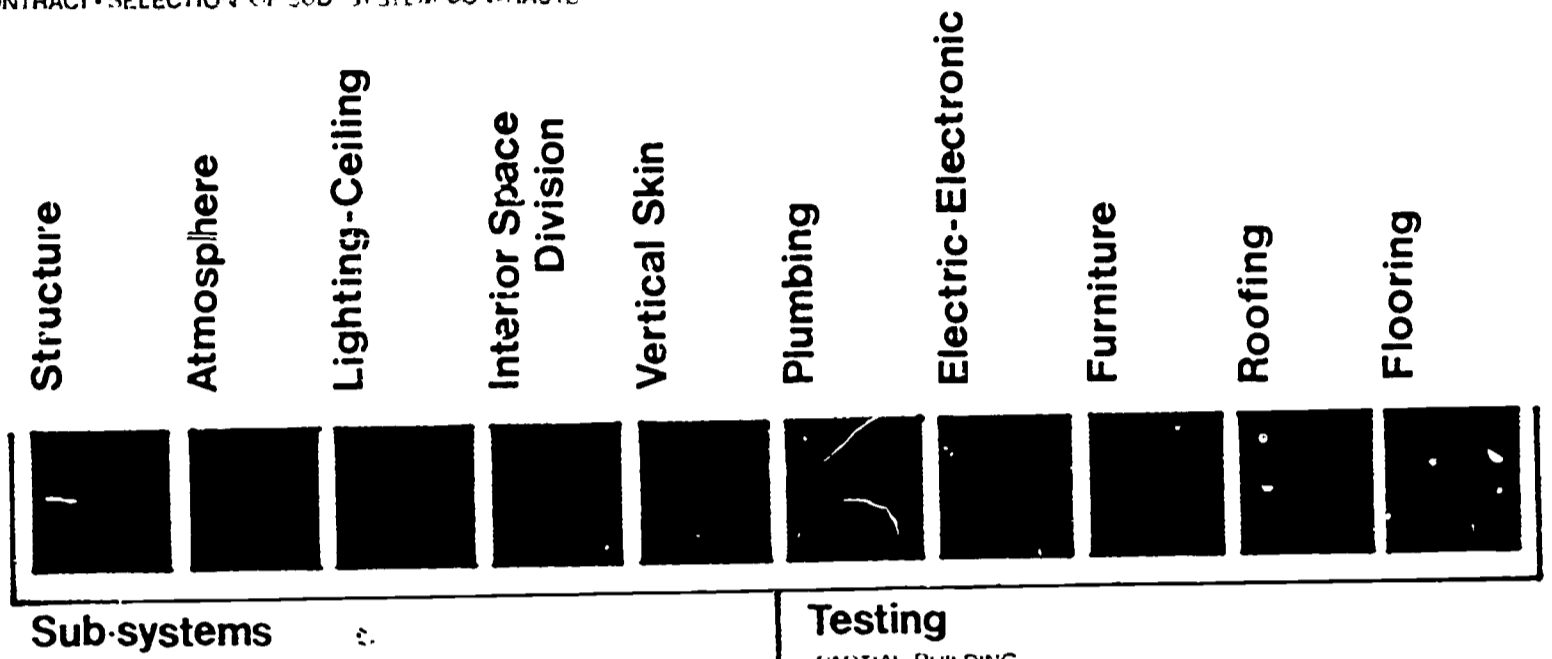

Testing  
PARTIAL BUILDING

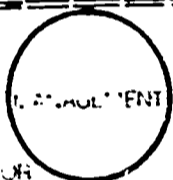

SERIES TWO CONTRACT - SELECTION OF GENERAL MANAGEMENT CONTRACTOR

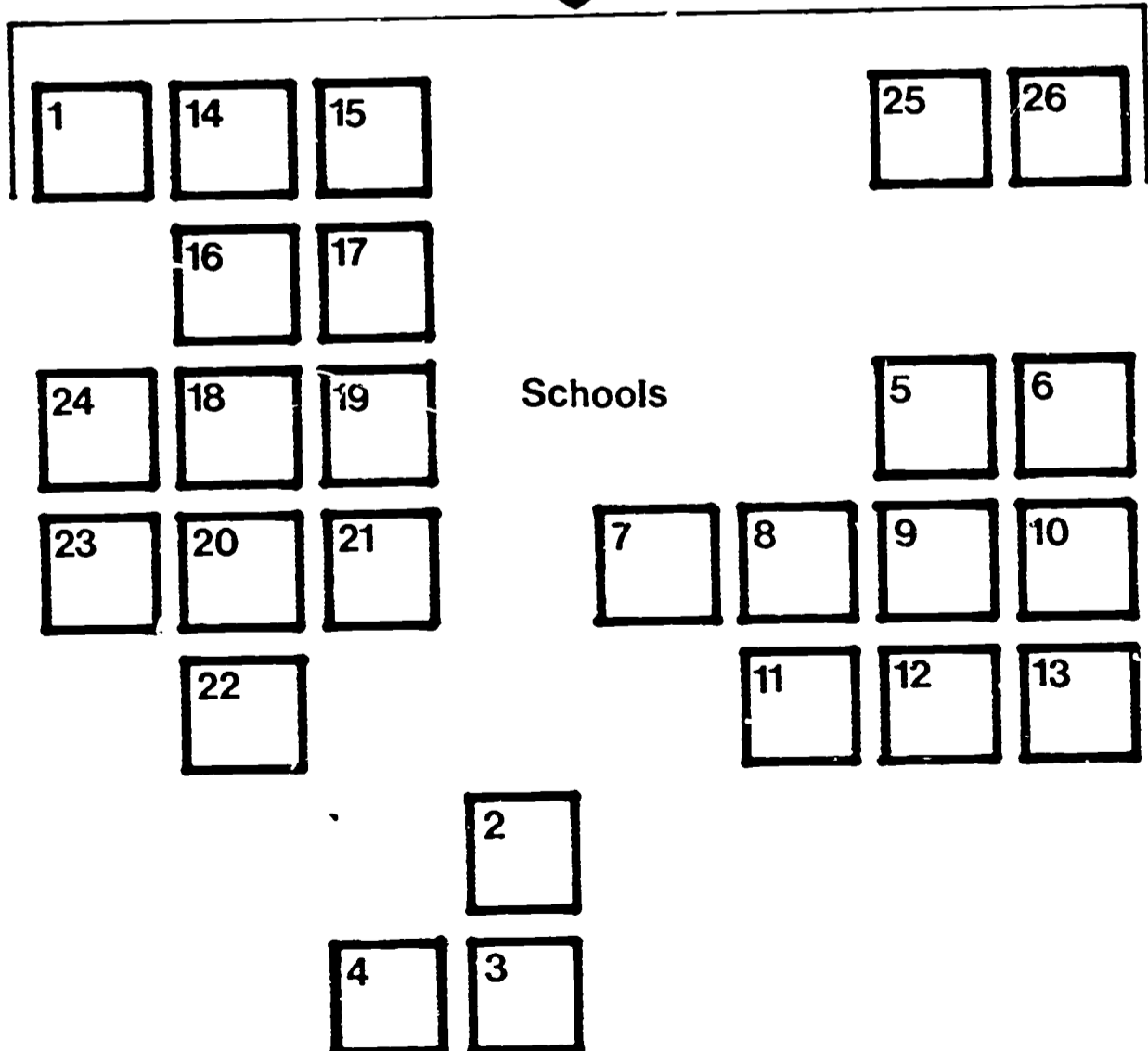

SEF COST COMPARISON

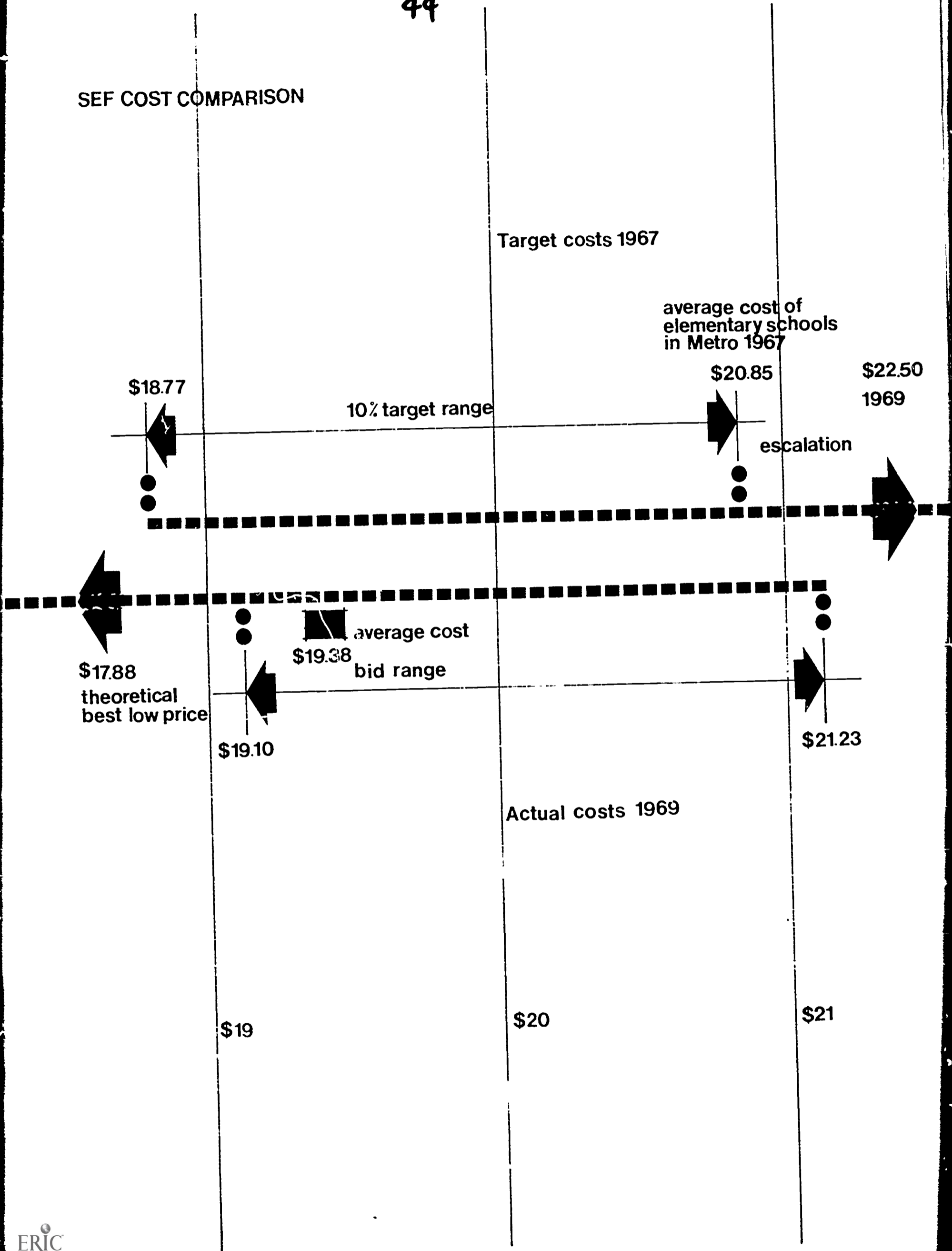

Construction consultants have been appointed for from one to four projects per borough for a fee ranging from 4.37% to 2.90%. A number of work items usually included in general contractors' overhead have been covered by cash allowances under SEF.

In order to execute the program SEF has been reviewing in detail all aspects of school job management. Due to the extremely close time limits that have been observed on the project, architects have had to progress their work under difficult conditions of lacking final catalogues, and management handbooks.

#### Summary Observations.

The SEF project has succeeded first because of the unswerving backing given to the program by the Metropolitan Toronto School Board, and through the great cooperation that was forthcoming from the industry. For its part SEF attempted to be clear and consistent in its requirements. Wherever possible, SEF requirements were settled by negotiation with the building industry.

The principal example of the latter is the finalization of the contents of documents T1 and T2. In both cases they were written and printed in full in draft form and sent to 1,000 companies, firms and individuals in the building industry. The recipients were given six weeks in which to furnish written criticism on any aspect of the program. As a result of this process, which enabled the industry to evaluate the SEF specifications against the SEF budget, many changes were made to both documents T1 and T2.

While the system sought to give maximum freedom to the designer it has limited his choices, being a closed-open system. It was because of this compromising of a project architect's and engineer's freedom that bidders were required to have their submissions stamped by an architect and engineer registered in the Province of Ontario, thereby ensuring for the owner's protection, a continuity of professional representation from sub-system concept to incorporation in a specific building design.

The addition to the Eastview Public School, a 13,000 square foot two-storey structure, was started in the second week of April 1969 to test the validity of the First SEF Building System. Two weeks later, a series of construction industry lock-outs and strikes started which lasted 101 days. The building was 95% complete and occupied by students on 2nd September 1969. In early August the Roden Public School, a three-storey 82,000 square foot structure on a confined city site, was started, and despite a ready-mix strike is only 3 days behind the original project schedule. Steel commenced erection on this project on 15th September 1969, and the building is due for completion 15th February 1970. Eleven other schools will be completed by 20th July, 1970.

The caseworks sub-system, for which tenders were recently received, appears to be a major breakthrough in the development of school furnishings. It has been designed to exploit the total flexibility of the building system to the limit.

It is my view that the open systems approach to building set in the context of North America's industrial capabilities, can bring about a massive upsurge in the continent's economic potential. I believe the open systems approach through its flexibility permits a very wide utilization of national productive capacities when compared with the closed systems approach. The method can of course be applied to any building type.

## APPENDIX 1

**TERMINOLOGY** - The following is a brief system building terminology. A more complete version may be found in Appendix "A", SEF Document T-1, Introduction to the First SEF Building System.

**System Building** - The technique by which any building project may be handled in the most efficient way within the economic, social, political, spiritual and aesthetic, and other limitations of the place in which it is being done. A more precise definition might be: The application of interrelated and integrated quality, cost and time control procedures to the entire building process.

**The Systems Approach to Building** - means approaching the entire process of analyzing the need for a building, from the point in time when the need for a building first manifests itself, through the construction of the project to its final use, in the most orderly and universally satisfactory way possible. "The systems approach to building" means more than being efficient and practical, it includes also the satisfactory handling of the intangible aspects of building, usually lumped under the much abused terms, amenity and aesthetics.

**Building System** - A building system is a set of building parts which have been conceived and manufactured to assemble without adjustment or waste.

This is the modern definition; the older and more widely accepted version might be: Building Systems are ways of building, involving the use of specific skills and materials. Building systems include all known ways of building both ancient and modern. The Roman mass concrete way of building was a building system in the same way as is the traditional modern framing and cladding technique used for North American houses.

**Building Process** - The process which embraces every stage from the conception to the total satisfaction of a building requirement.

**System** - Another term in common use is "System". Here, I think the definition used by Progressive Architecture Magazine in its August, 1967 (No. 8) issue is excellent for the purposes of building.

"A working totality formed of often diverse but integrated parts, subject to a common plan or serving a common purpose." A detailed review of the term may be found on page 109 of the above journal.

**Sub-System** - It is an identifiable, complete, designed, physically integrated, dimensionally co-ordinated, installed series of parts which function as a unit within prescribed performance limits.

**Open (Building) System** - It is a building system having externalized interchangeability of its sub-systems.

**Closed-Open (Building) System** - It is a specific choice of sub-systems from the range which constitute an open system.



Closed (Building) System - (1) Is a building system having only internalized interchangeability of its sub-systems. (2) Is a specific choice of sub-systems within an open system.

Non-System - Non-system covers that work required to complete a building project, which is not covered by the scope of the sub-systems of an open or closed-open building system, or by the building system in the case of a closed building system.

Module - Another term which has great contemporary currency in modern building is the term "module". It appears to be misused by a majority of architects and the general public and all laymen. The misuse of the term might suggest that its meaning should be changed to conform to popular understanding. The definition originally given by the European Productivity Agency, and reiterated by the Royal Institute of British Architects, The Canadian Standards Association, The Metropolitan Toronto School Board, Study of Educational Facilities and others is--"a module is a convenient size which is used as an increment or coefficient. It is a unit of a size. Small "m" is used to denote the common concept of a module." In the view of the authorities quoted and in academic building circles, the term "module" is usually understood to mean the basic unit of size used in the design of a building project, such as a dimension of 4" from which all other dimensions on the job are derived. To the public and a majority of members of the building industry, the term is often confused with the planning grid on which a building design may be based. This latter is usually a dimension of several feet. Strictly speaking, a planning grid has a multi-modular dimension, to use the academically correct jargon. As there would appear to be an underlying commonsense to the public's acceptance or rejection of quasi-technical jargon, it might reduce misunderstanding in future North American building circles if the use of the term "Module" underwent some immediate semi-modification.

I would like to suggest that the term "module" be retained in its present technical-academic definition, due to its wide inclusion in many national and other building standards, and that the term planning grid be dropped in favour of "building module". Such a switch would make sense of the whole business of industrial building to the technical and lay publics.

(CSA A31-1959, p.8, and RIBA, 1965, p.20)--A convenient size which is used as an increment or coefficient. It can be any dimension, it is a unit of size. Small "m" is used to denote the common concept of a module.

Building Module (Grid) (Planning Grid) - The basic dimension used in plan and elevation to determine the overall size of a building, the spacing of its principal structural elements, and the principal dimensions of the components of space defining building elements. The building module is usually shown in the form of a square grid on the project design and working drawings. (In the case of SEF, this is a 5'-0" grid in plan.)

Grid Line - A line on a building module grid.

Interface - Is the point of contact or blending of two objects, systems or activities.

Interface Compatibility - Is the process of tying together cost and performance between adjoining sub-systems of differing manufacturing origin.

Interface Contract - A contract between sub-system contractors specifying the precise division of responsibility at an interface.

Interface Tendering Method - A method of tendering originated with the Metropolitan Toronto School Board's Study of Educational Facilities (SEF) school building project in 1968, whereby tenderers at mandatory interfaces between sub-systems reflect the interface compatibility of their sub-systems through a process of competitive base bid prices with penalty loadings for incompatibility, in an open system context, in response to sub-system performance specifications.

Tolerance - (CSA A31-1959, p. 11) - Tolerance means the difference between the permitted oversize (upper limit) and the permitted undersize (lower limit). This difference is always positive. All tolerances relative to an interface plane are negative. Within this negative interface tolerance, manufacturing tolerances will be positive and negative. An interface plane between sub-systems, and/or components may be a planning grid, or a plane of division between separate components which form a greater entity.

Program - Time control procedure, used to organize a series of activities into an efficient order.

Programming - Time and activity co-ordination of a process in whole or in part.

## TOLERANCES: STANDARD CONVENTIONS

Procedure in principle for calculating the Maximum and Minimum sizes for a modular component

1 Define the Modular Size ( $nM$ ) of the component

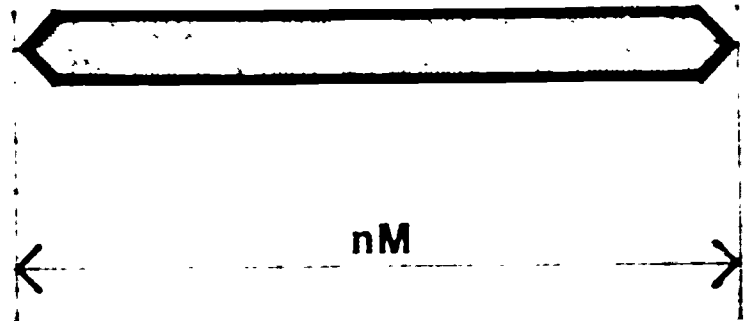

2 Define the Minimum Gap  $g$



3 Define the Positional Tolerance ( $p$ )

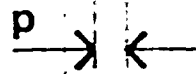

4 Define the Manufacturing Tolerance ( $t$ )

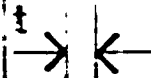

When the above have been settled, make the following calculations

5 Determine the Minimum Deduction:  $g + p + g$



6 Determine the Maximum Size:  $S = nM - (2g + p)$

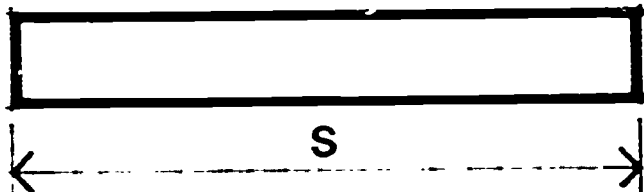

7 Determine the Minimum Size:  $s = S - t$

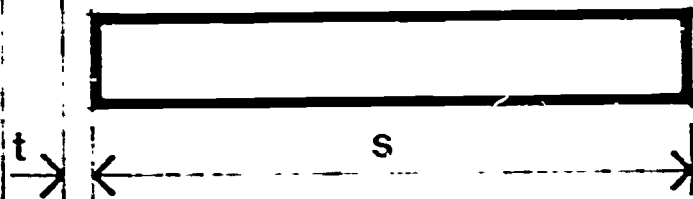

8 Check the Maximum Gap ( $G$ )  $G = g + p + \frac{1}{2}$

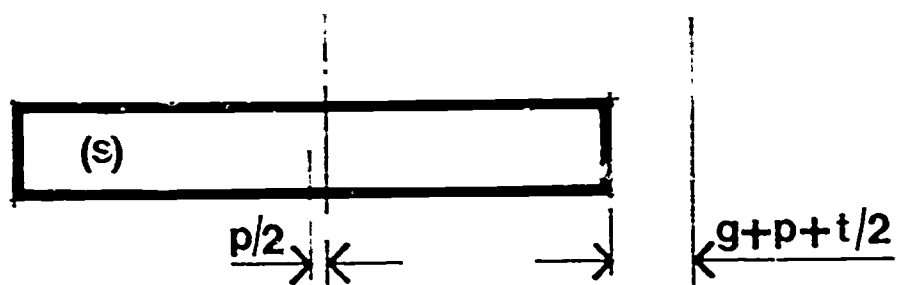

9 Check the Minimum Gap ( $g$ )  $g = \frac{1}{2}(nM - S - p)$  and check against 2 above

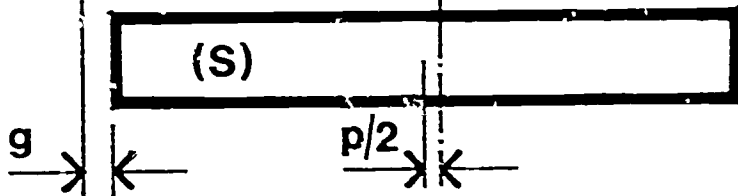

**Minimum Gap.** The Minimum distance between the co-ordinating face of a component and a modular or other reference plane

Royal Institute of British Architects  
The Co-ordination of Dimension for Building  
(London: Royal Institute of British Architects, 1965)  
p. 61. Reproduced by permission of the  
Royal Institute of British Architects

TOLERANCES

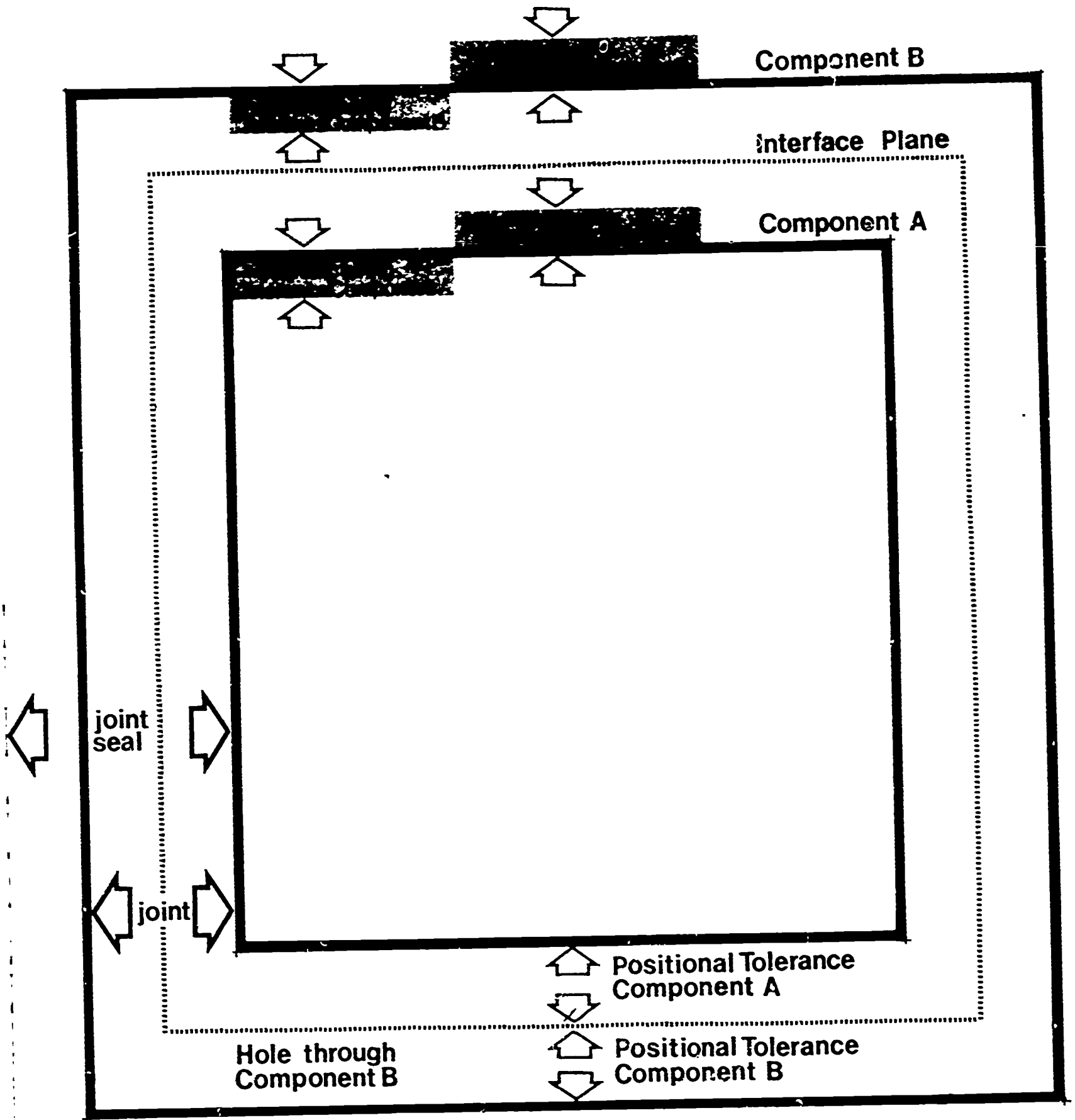

TOLERANCES FLOOR TO FLOOR COMPONENTS

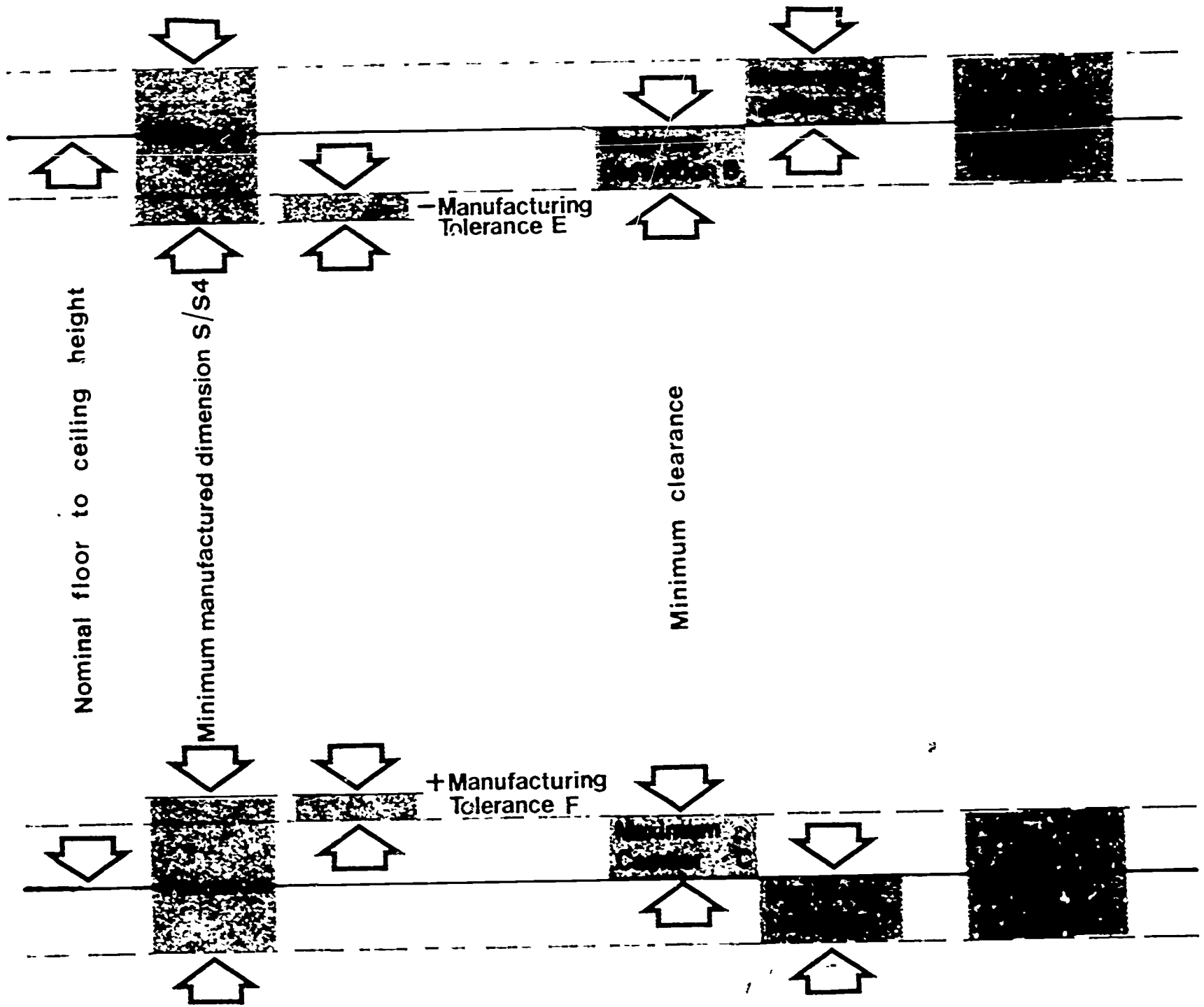

Maximum Tolerance  
 = 2 (Tolerance)  
 = (A+B+E) + (C+D+F)

APPENDIX 2

SCSD introduced the performance specification to building, while retaining competitive bidding. The specification stated what part of a building should do, but not how or with what. These latter considerations were the responsibility of the bidder as part of his proposal. Through this means a very wide cross section of the skill within the building industry could be focussed on the program.

SEF has sought to extend and radically broaden the work started by SCSD and has been most successful in this respect.

Because the closed building system was restricting in its application, and favoured a monopoly approach which could reduce competitive tendering, it was rejected by SEF.

The open building systems approach was selected for various reasons:

- (1) Economy through wide application. - Because its sub-systems are externally interchangeable, the open building system lends itself to economic application on both national and local level. The basic design of the sub-systems can be developed by a wide variety of disparate interests, or by research groups serving whole industries (associations of steel, concrete, lighting-ceiling products, etc.)

In either case, common standards of dimensional co-ordination and performance govern the design and manufacturing of these sub-systems ensuring that the parts fit together accurately and effectively in the finished building. Because of these common standards, even geographically remote companies and contractors can manufacture, fabricate and erect the sub-systems.

It is relevant now to suggest that the need for common standards, resulting from the use of an open building systems approach, creates the need for a very widespread industrialization of the entire building industry. At present, only isolated fragments are industrialized. One is therefore able to find standardization taking place within the masonry industry, or within the steel industry, or within the mechanical services industry, but very little taking place between these industries to facilitate dimensional and functional integration of their components in the finished building. In addition, although actual performance of the building industry has indicated that it is capable of producing an almost infinite variety of materials, many of these involve only short production runs. Consequently, the expense derived from designing and fabricating numerous parts is in no way reduced by the economic advantages of longer production runs.

It was proposed that through the application of industrialization, dimensional co-ordination, standardization and the integration in a finished building of components of different manufacturing origin, the open building system would make realistic an extension of production runs of the components. In turn, these runs could exploit the most efficient methods of manufacture and assembly. This would

provide a practical opportunity for real economy in building construction.

As opposed to current methods which seek to reduce building area or reduce quality as a means for gaining economy, it is now realistic to assume that the open building systems approach can lead to actual long-term cost reduction without a lowering of standards as has been shown by the SEF tender.

- (2) Highest potential quality through wide application - By opening a potential market for sub-systems suitable for school construction, the use of an open systems approach has elicited a strong response from industry. The opportunity to assemble bulk orders of certain standardized components has made possible the utilization of the massive, and seldom applied, collective skill of the building and building products industries. This collective skill has been exploited in both research and development of sub-systems. Higher quality of materials within given cost limits has resulted.
- (3) Greatest variety of choice - Through the integration of materials of varying origin in an open building system, it is possible to offer the designer numerous choices of assembly of a finished building. If ten sub-systems exist within a system and there are four acceptable solutions to each sub-system, 1,048,576 specific systems can be developed and on SEF there are 13,000 systems below the target budget. Almost infinite variety is available. The degree of choice offers owners and architects freedom of design and layout, within the context of the open building system. The choice also enables manufacturers and contractors to organize their production and development on an industrial mass production basis.
- (4) Cyclical building renewal - The primary concern of SEF was to provide flexibility of interior parts by selecting a building system which would offer maximum interchangeability of its sub-systems components. This was the essential reason for choosing an open systems approach. Flexibility necessarily adds a time dimension to the moulding of space. The application of an open building system affords the opportunity for cyclical building renewal or renewal of a building on a continuing basis.

In the past, the tendency has been to construct buildings on the more-or-less unspoken supposition that they will last forever. However, the spectacular scientific and technological developments currently taking place are bringing a sense of immediacy in human events and in the interpretation of these events in the physical environment.

This need for immediacy of interpretation, in turn, demands the ability to change the physical environment quickly to suit changing human, social, educational and health requirements. The concept of permanence in building design has begun to die.

It can be expected that the projection of the useful life of a building at the time of its design will become normal practice. Time plans will be developed on the premise that urban renewal will be a normal, healthy process of change in the living tissue of a city, rather than the wholesale demolition and rebuilding which has been associated with this concept.

The building systems of the foreseeable future will have built-in provision for renewal. Educational building is taking a lead in bringing this metabolic\* change to the building industry. The metabolic approach to design in the single building holds the view that:

\*...architecture is composed of two elements. First there is the spatial equipment which determines space itself, and second, the living equipment, which corresponds to living patterns. In all historical buildings we view the spatial equipment, but in contemporary architecture we place considerable weight on the living equipment. The spatial equipment is thought of as the spatial skeleton which is not subject to temporal changes in function. Occupying a subordinate position and attached to the spatial equipment in order to satisfy current requirements is living equipment. It is quite permissible if (1) its position changes in the future, (2) it is replaced by other equipment using different materials, or (3) it is replaced in order to meet changes in function. The term "Metabolism", ... can be understood to be the introduction into architecture of a method of replacing and changing the living equipment in accordance with living patterns.

The Metabolists are a group of Japanese architects formed in 1960 when the World Design Conference was held in Tokyo. The above material is quoted from Carl Hall "The Metabolists" The Canadian Architect, December, 1966, pp. 37-52.

- (4) Cyclical Renewal - Under the philosophy of cyclical building renewal, comprehensive building sub-systems have varying life (or renewal) spans. A suggested pattern may be initially:

#### PERMANENT PORTION OF THE BUILDING

Building Sub-System	Renewal Cycle
Structure, Vertical Skin (exterior walls)	30 - 60 years depending on the rate of social and economic change in a given society
Stairs	



## RENEWABLE PORTION OF THE BUILDING

## Building Sub-System

## Renewal Cycle

Roofing, Plumbing, Interior Space Division, Atmosphere, sub-systems, elevators, escalators, and other people-and goods-handling systems and equipment. 20 years

## Building Sub-System

## Renewal Cycle

Electrical and Electronic equipment, Caseworks, Lighting-Ceiling sub-systems, wall and floor, built-in finishes. 10 - 15 years

and later develop further:

PERMANENT PORTION OF THE BUILDING  
(THE SPATIAL EQUIPMENT)

## Building Sub-System

## Renewal Cycle

Structure Sub-system (#1)  
Vertical Skin Sub-system (#5)  
Roofing Sub-system (#9)  
Stairs - non-system  
Foundations - non-system  
Site works and sub-grade services - non-system  
30 - 60 years depending on the rate of social and economic change in a given society

RENEWABLE PORTION OF THE BUILDING  
(THE LIVING EQUIPMENT)

## Building Sub-System

## Renewal Cycle

Atmosphere Sub-system (#2)  
Lighting-Ceiling Sub-system (#3)  
Interior Space Division Sub-system (#4)  
Plumbing Sub-system (#6)  
Electric-Electronic Sub-system (#7)  
Caseworks - Furniture Sub-system (#8)  
Interior Finishes Sub-system (#10)  
People and goods, moving and handling systems and equipment.  
10 years  
As the turnover cycle of a fully industrialized building industry

A school board can phase its expenditures in relation to the changing financial circumstances of the community. For instance, by dividing the structure, the atmosphere system, electronic system, etc. into distinct sub-system categories and by designing these on a metabolic basis, it is possible to assign amounts to each of these areas, in accordance with the life span that might be expected for each section. Proportionately then, more money might be spent on the structure of a building and less on the caseworks sub-system, in the expectation that the latter could be replaced when more funds were available to the community. By this means, it is possible to stage

capitalization for periods of favourable economic conditions. Because all aspects of the school do not have to be built within the economic limitations of a given period, the most desirable performance characteristics in schools can be achieved. In addition, this principle ensures that products can be designed to last for a given life span and avoid functional obsolescence.

By accepting the concept of cyclical renewal for the building and the sub-systems, the way can be opened for the development of components having a specific life span which might be marketed under a series of lease-rent arrangements. As in the case of computers and certain other items of complex machinery, a manufacturer might sell the service of a sub-system rather than the product itself. In such cases, the manufacturer might also undertake maintenance of the sub-system during the life of the lease. Alternatively, a dealership system, similar to that used by the automotive industry becomes feasible. By this means, used sub-systems could be traded in, renovated and re-sold for use in other buildings, with a consequent upgrading of both the physical environment and the economy.

- (5) Open-ended evolution within a given building installation - The potential for cyclical building renewal offered by an open building system suggests the possibility of renewing any school project on a continuous basis.

Examination of the life-cycle of a traditional school project indicates a process of growing obsolescence from the date of construction, with perhaps an occasional major updating, to final total obsolescence, possibly in the last twenty-five per cent of its life. It is suggested, that the open building systems approach, together with the cyclical form of building development proposed, the violent peaks and valleys of improvements and obsolescence common in traditional construction can be avoided. The process of change can be a smooth series of events, with parts or whole sub-systems being replaced during the life of the building as they become obsolete. It would be virtually possible to replace a building on the same site, without ever totally wrecking it. For instance, a building could be mutated over a number of years from a permanent structure, to a relocatable structure, by using the up-dating process of sub-system replacement. The original permanent sub-systems would be replaced by newer relocatable sub-systems. If the original exterior walls and roof were supplanted by a large space-weather enclosure, such as a dome or tent-like structure, even the basic structure of an older building could be seriously modified.

By requiring the development of sub-systems to take into account the possibilities of long-term, open-ended evolution, an opportunity is presented to the building industry to organize itself on the basis of known demand which the industry could itself aid in creating. Advanced developments in technology can be exploited on a continuing basis and to a greater degree than has been currently possible in the building industry.

In order for sub-systems to be interchangeable, they must have interface compatibility. This means that each of the ten sub-systems which comprise the First SEF Building System must integrate both physically and functionally with other sub-systems to which they abut in a finished building. For example, the beams, columns and joists of a structure sub-system are designed to fit together easily and economically in the field. The boilers, chillers, fans, ducts, pipes and controls of an atmosphere sub-system are similarly conceived. To achieve interface compatibility between the structure and atmosphere sub-systems, it is necessary that the parts of the sub-systems which come in contact with each other fit efficiently.

The First SEF Building System is a "closed-open" system, comprised of ten sub-systems.<sup>1</sup> The components and sub-systems have been developed, fabricated, and erected by industry in open competition. The sub-systems were conceived in such a way as to permit use of any other school project in the Metropolitan Toronto area. They have been integrated into the designs of specific projects, each with its own architect and general contractor.

Not until the sub-systems tender was complete and the partial building is accepted by SEF are the details of the system known. At this point, the particular choice of sub-systems "closes" the system for the selected group of projects.

---

<sup>1</sup>A sub-system is an identifiable, complete, designed, physically integrated, dimensionally co-ordinated, installed series of parts which function as a unit within prescribed performance limits.

## APPENDIX 3

The 5'-0" x 5'-0" horizontal planning grid was selected because:

- (1) It fits accurately to the space requirements recommended in the SEF academic research studies (E.1), and it satisfied The Metropolitan Toronto School Board's Ceiling Cost Formula.
- (2) Since it is the largest planning grid which fits the basic space requirements, it reduces joints to a minimum.
- (3) The planning grid accepts the 4'-0" fluorescent lighting tube in a variety of arrangements with an adequate allowance for partition thicknesses and other obstructions of the ceiling plane surface. Among major manufacturers of lighting-ceiling systems who were consulted, there were requests, on grounds of economy, to specify 4'-0" fluorescent tubes rather than 3'-0" tubes.
- (4) Since the 5'-0" planning grid has been used for the SCSD project in Southern California and will be used for the Florida State School Building Program, a number of building materials based on this planning grid have already come into existence.
- (5) It is approved by a variety of structural, lighting-ceiling, partition, and vertical skin product and component manufacturers.
- (6) Since it is commonly used in commercial building, the sub-systems of the First SEF Building System can be directly applied to buildings other than schools.
- (7) The large ceiling grids formed on the planning grid provide a relatively tranquil visual environment.
- (8) It appears to have dimensional appropriateness; most partitions align themselves on this planning grid.
- (9) It can be divided into a 20" sub-grid which has been suggested as a suitable grid in the design of residential high-rise buildings. Materials and sub-systems designed to fit this residential planning grid could be used in buildings using the 5'-0" x 5'-0" planning grid.

# HORIZONTAL PLANNING GRID

