

ED 031 914

EF 003 467

University Residential Building Systems (URBS). Phase I Report, Revised December 1966.
California Univ., Berkeley. Dept. of Physical Planning and Construction.

Pub Date Dec 66

Note - 60p.

EDRS Price MF -\$0.50 HC -\$3.10

Descriptors - *Building Design, Building Materials, *College Housing, *Component Building Systems, *Construction Costs, Performance Criteria, *Performance Specifications, Programing, Research, Student Needs

Identifiers - University of California

The University Residential Building Systems (URBS) project is a major program of research, design, development and construction with the object of obtaining and using compatible building components in the construction of university student housing. This is accomplished by providing incentive to industry for development of new products that will meet predetermined performance requirements. Analysis of student needs, programing and design requirements are the foundation for the performance specifications, a set of requirements to guide industry in the design and manufacture of building components. Performance grading which evaluates--(1) initial cost, (2) satisfaction of user needs, and (3) expected operation and maintenance cost is the method used to judge the different building components. Detailed studies of existing buildings are presented which analyze performance and projected maintenance cost against capital cost. Also presented is--(1) a list of manufacturers interested in URBS, (2) an organization chart, and (3) a list of members of the national advisory committee. (TC)

ED031914

UNIVERSITY RESIDENTIAL BUILDING SYSTEMS (URBS)

Phase I Report

Based largely on information and data obtained and evaluated by Building Systems Development, Inc., under contract with the University of California.

(Originally presented to the Board of Regents on November 18, 1966 and subsequently revised.)

U. S. DEPARTMENT OF HEALTH, EDUCATION & WELFARE
OFFICE OF EDUCATION

THIS DOCUMENT HAS BEEN REPRODUCED EXACTLY AS RECEIVED FROM THE PERSON OR ORGANIZATION ORIGINATING IT. POINTS OF VIEW OR OPINIONS STATED DO NOT NECESSARILY REPRESENT OFFICIAL OFFICE OF EDUCATION POSITION OR POLICY.

Revised DECEMBER 15, 1966

OFFICE OF THE VICE PRESIDENT
PHYSICAL PLANNING AND CONSTRUCTION

EF 003 467

INTRODUCTION

The University Residential Building Systems (URBS) project is a major program of research, design, development and construction to obtain and use new, mutually compatible building components in the construction of university student housing. It is expected that this effort to obtain new products which are not now on the market will result in housing of better quality and at lower cost than that presently available.

As used in the URBS program, a component is an assemblage of related parts which work together to perform a particular function for a building, e.g., the structural system, or the plumbing system.

The particular components selected for inclusion in the URBS project represent 50% to 60% of the building cost and are:

1. The structural system above the ground floor, including ceiling and floor finishes;
2. The heating-ventilating and heating-air conditioning systems;
3. The partitions--fixed and demountable, including doors and their hardware;
4. The casework and furniture, including student room lighting fixtures; and
5. Student bathrooms.

Other components, while equally susceptible to improvement, have been excluded from this program because the variations at the nine campuses of the University of California do not provide the volume required to attract the desired level of research and development by industry. Some of the more important components excluded from the URBS program are:

1. Site development work;
2. Foundation work up through the ground floor;
3. The exterior skin;
4. Roofing;
5. The electrical power distribution system; and
6. The main plumbing supply and waste system.

The URBS program utilizes an approach to the selection of the components of a building which differs from the conventional one. The conventional approach is to select and use products which are already available from industry. Although historically this approach produces a satisfactory building at

the time of its initial occupancy, it requires the expenditure of an appreciable amount of time and money for the architect to correlate the components properly during the design and construction phases so that the components work together compatibly. Moreover, once constructed, such a building is not easily changed or remodelled within a reasonable cost context to accommodate changing programs. Also, under the conventional approach, the long term performance of the available "on-the-shelf" equipment or component is incidental, rather than paramount, in relation to the future use and maintenance of the building.

Currently, any departure from available products presents a dual economic problem: (1) to the client who usually is unable to afford the cost of innovation, and (2) to industry which understandably hesitates to invest sizable sums necessary for research and development of new products without assurance of a broad market. Thus an impasse in the progress of building design has been created.

The URBS program is a major effort to overcome this impasse by providing an incentive to industry of sufficient magnitude to warrant risking capital in the development of new products that will meet predetermined performance requirements.

The incentive offered by the University of California is a guarantee to construct housing for at least 4,500 students. The initial group of student residences using the URBS components is scheduled to open in September 1970 on several of the University's nine campuses. Additional units are scheduled to open on the other campuses in 1971 and 1972. Provision will be made for both single and married students (lower division, upper division and graduate) in both low and high rise structures. The University has been assured by industry representatives that the URBS program is an adequate initial market, and the continuing market can be provided by the other 2,200 colleges and universities in North America. The parallel to the general housing market gives additional incentive for industry whose willingness to sponsor the research, design and development of new components is the major key to a successful project.

The URBS Approach

The URBS approach to obtaining new components is through the use of bidding procedures based on "performance specifications" rather than on the conventional specifications. The latter tells in detail the products to be used and the way in which they are to be used. The performance specification (as its name implies) tells what the particular component is required to do, and leaves to the bidder the decision as to how he proposes to provide the required performance.

This method makes it possible for each manufacturer to bid on his own research, design and development work in a manner which will permit good competition while protecting his individual interest. Subsequent careful evaluation of all bids, and extensive testing of all proposed components, will assure the University of an end product which will serve its requirements better and presumably at less cost than now obtainable.

The URBS Procedure

The procedure being used in the URBS project has been divided into four phases:

PHASE I: Compile the broad range of user requirements for university student housing and begin translating these into performance specifications.

As stated above, performance specifications differ from conventional specifications in that they only state the problems and make no attempt to provide answers. In order to identify the problems, a long series of conferences and discussions was held with users of the buildings (the students, administrators, and faculty) to determine their actual requirements.

One of the most important of these user requirements, as had been suspected, is the need for flexibility so that building changes required or desirable during a forty-year amortization period can be economically accommodated. The URBS program therefore places emphasis on flexibility--not only at the time of construction but also throughout the life of the building. This flexibility will be obtained by modification and relocation of the building components within a realistic cost context. It should be noted that flexibility does not mean that campuses are committed to unconventional plan layouts. A flexible residence hall can accommodate a conventional program; however, a hall design from conventional components usually is not able to accommodate an unconventional program. A preceding program (School Construction Systems Development; SCSD) has shown that with adequate research, flexibility does not add to the cost of the products and significant savings in building alterations can thus be realized throughout the life of a building.

The Phase I Report which follows this Introduction outlines the major user requirements as they were determined, suggests what might be included in some of the performance specifications, gives in brief form some of the building performance and cost studies undertaken to date, appends information as to the organization for this project, and indicates the interest of various industries. It does not contain specifics as to what any of the building components should be or what their cost will be; this will become known as Phase II develops.

PHASE II: Complete the performance specifications and invite industry to submit bid proposals for building components that answer the problems posed in the performance specifications.

Industry will be asked to include in their bids the installation of the components in the individual buildings as well as a proposal for their long term maintenance. Bids will be subject to aesthetic standards and cost targets specified by the University. Industry's efforts will be correlated during the bidding period to assure mutually compatible components.

PHASE III: Evaluate the bids, nominate the potentially successful bidders, test the prototype components for compliance, and award contracts to

the nominated bidders whose components most successfully comply with the performance specifications.

The award of contracts for the new building components will be made on the basis of initial construction plus the maintenance plus operation costs on an appropriate long term basis--up to forty years for some of the components.

PHASE IV: Use the accepted components in the conventional way; i.e., in design of the individual buildings by architects in private practice, with construction on a bid basis by general contractors.

Under this procedure the University will transfer the contracts for the new building components to the general contractor for each building. Even after the buildings are completed and in use there will be a continuing program of inquiry to ensure high quality performance.

URBS Management

The authority to proceed with this project was approved by The Regents of the University of California and the Educational Facilities Laboratories, Inc., in the fall of 1965. Subsequently a contract was entered into with Building Systems Development, Inc., a California corporation, to conduct the major part of the research, evaluation and correlation required to assure mutually compatible components.

The overall direction of the project for the University of California is the responsibility of the Vice President - Physical Planning and Construction. To assist in evaluating the results of the various stages and phases of development, President Kerr appointed a National Advisory Committee composed of prominent educators, architects, engineers and administrators. The outline of the University's organization for management of the project, and the membership of the National Advisory Committee, are included as a part of this Phase I Report.

TABLE OF CONTENTS

Phase I Report

	Page
PART I. USER REQUIREMENTS	2
PART II. PROGRAMMING AND DESIGN	12
PART III. PERFORMANCE SPECIFICATIONS	18
PART IV: PERFORMANCE GRADING	23
PART V: COST STUDIES	32
PART VI: GENERAL INFORMATION	57
A. Industry Interest	58
B. Organization for Project Management	61
C. National Advisory Committee	62

PART I. USER REQUIREMENTS

The student residence is a social organism. The dual relationship of students one to another, and the students' activities to the physical arrangement of the building can be studied usefully. There is need to experiment with these relationships and also to allow for change through variety and flexibility.

1. Variety: provides for a range of preferences at any given time: e.g., single room, double room, suite or apartment. It may offer the choice between high-rise or low-rise buildings, or between modest or more luxurious facilities. These choices are of immediate value to the student.
2. Flexibility: provides for the ability to change internal layouts of the building, to respond with the passage of time to evolution of the University's requirements. Flexibility is of value to both student and the University. University requirements undergoing evaluation are:
 - a. Long-term changes in student mix, percentage of married students and minority races.
 - b. University policy--decentralization, financing, loco parentis.
 - c. Educational philosophy and technique--inclusion of academic space, teaching aids, electronic terminals.
 - d. Emergency reasons--over-assignment, fire, community disasters.

Phase I of the project has concerned itself primarily with a determination of user requirements to establish the range of relationships that need to be accommodated. This has been accomplished by several meetings on each campus (except San Francisco Medical Center where a minimum of housing exists and where there are no immediate plans for additional housing) and in visiting other campuses throughout the country. In the case of the University of California campuses, the meetings have included the Chancellor or his immediate staff, students, deans of students, operators of residence halls, campus architects, and representatives of the academic community. This same pattern was followed in visiting other campuses insofar as possible. In addition, a considerable amount of written material has been evaluated.

The user requirements study has produced a wide range and variety of ideas. These have been compiled and summarized, and may thus serve as a guide to the campuses in their initial programming of future student residences. However, the immediate use of the study by URBS is to serve as the basis for the preparation of the performance specifications which industry will use as the statement of the problem they are asked to solve. The summary of the user requirements follows:*

* Additional details are available in two other reports:

User Requirements: Detailed Discussion
October 21, 1966

User Requirements: Technical Appendices
October 21, 1966

A. GENERAL GOALS AND URBS GUIDELINES

1. General Goals (as approved by the Standing Committee on Residence Halls)
 - a. University of California should provide wide variety and flexibility in the student housing on each campus, particularly in building layout and interior arrangement.
 - b. Student preferences must be accommodated whenever possible.
 - c. The level of physical environment and design must be raised in ways which are of real value to the student, i.e., thermal and ventilation, lighting, color and texture, acoustical and privacy.
 - d. Minimal space allocations of 200 square feet per student recently used will not answer needs. The area per student should be increased to approximately 260 square feet.
 - e. Single rooms should be provided for upper division and graduate students as campus requirements change over a period of time. The minimum size should be 110 square feet if the traditional study, sleeping, and social functions are housed within the room.
 - f. The minimum size double room should be 180 assignable square feet; but for full flexibility 200 square feet is desirable.
 - g. Small bathrooms should be basic to future student residence designs if their cost can be made comparable to gang bathrooms.
 - h. Large dining rooms must be divisible into smaller units.
 - i. Large lounges should be supplanted by more small ones.
 - j. Provisions for academic use space in student residence may be important for the future.
 - k. Single and married student housing must be provided.
2. URBS Guidelines (as approved by the Standing Committee on Residence Halls)
 - a. Components must be so developed as to allow freedom of architectural design.
 - b. It must be possible to design and build all basic plan types with the system. These range from double-loaded corridors, as at Berkeley and Los Angeles, to the vertical house as at San Diego.
 - c. No element of the building system need be seen on the building exterior unless the designers choose to do so.
 - d. Both high-rise and low-rise buildings should be considered.
 - e. Interior components should allow maximum freedom for the expression of individual student personality.

(A2. URBS Guidelines continued)

- f. Immediate changes, by moving furniture and a limited number of screens or partitions, by students, should be possible.
- g. Long-term flexibility should be provided for by systems of partitions and mechanical components movable by professional or custodial staff. The main constraint is location of bathrooms, stairs and elevators which are fixed.
- h. Rules restricting student activities should not be affected by the use of building components.

B. ENVIRONMENTAL CONSIDERATIONS

1. Thermal

The heating, ventilating, and air-conditioning systems should allow for individual adjustment. Students should be able to open windows. There is a need for two types of systems to meet the different campuses' needs--a heating and ventilating system, and a heating, ventilating and cooling system.

2. Lighting

Lighting that permits the brightness-contrast ratio to be held to 10:1 should be provided in the study areas. The functional and aesthetic qualities of most lighting fixtures can be greatly improved.

3. Acoustics

Quiet is the most important single environmental factor for students. Doors and ventillating systems are weak points in acoustical separation.

4. Color and texture

Use should be made, as far as possible, of student choice in color and variety in texture.

5. View

The variety of landscapes encompassing the University of California campuses should be exploited and enjoyed. Structural systems must accommodate sloping sites.

6. Walls

Walls should provide for a variety of colors and surfaces. It must be possible for students to attach objects to any wall with minimum restriction.

7. Ceilings

Ceilings need to provide an acoustic absorbent surface, except where use of carpeted floors reduces this requirement. The conventional hung ceiling is not sufficiently robust to be satisfactory.

(B. Environmental Considerations continued)

8. Floors

Carpet is a desirable floor surface for most uses. Bathroom floors presently are expensive and a source of trouble.

C. STUDENT CATEGORIES

The User Requirements must consider the range of needs of the different students that a student residence program accommodates.

1. Undergraduate: tends to meet people, to need encouragement for study, to engage in much socializing.
2. Graduate: tends to place more emphasis on study and less on socializing.
3. Married student: often suffers from the lack of privacy for study.
4. Commuter: may find difficulty in becoming an effective contributor to the campus community.
5. Foreign student: may require help in relating to the student residence programs.
6. Physically handicapped student: often requires special design considerations.

D. SPATIAL ARRANGEMENTS

1. Student Living Arrangements

a. Single room

The room should provide opportunity for socializing with others in addition to use for study. The room should not have the atmosphere of a bedroom.

b. Double room

Lack of privacy is a major disadvantage. Students who live in double rooms need many outside facilities.

Movable wardrobes help room flexibility, but size of room is very critical. Most present double rooms are too small to allow good alternative layouts.

c. Split-double room

This room type provides two spaces with a connecting opening, thus recognizing a conflict of interest in activities. The separation should be acoustic if the spaces are to be effective. The split-double is an optimum arrangement where two students must share space.

(D1. Student Living Arrangements continued)

d. Triple rooms and up

There are increased problems of privacy with these room types. Such types are not recommended.

e. Suites

(1) A suite is a living arrangement in which four or more students share at least one common space in addition to the bathroom.

(2) Maximum flexibility is ensured if the recommended minimum area allotted to single rooms forms the basis for suite layouts. Initial layouts may include various arrangements of double, split-double, single rooms and common spaces, but must have relatively easy convertability to other arrangements as needs change.

(3) Many existing suite arrangements fail to provide for privacy in sleeping and study. The planning of the relationship between the living areas, common spaces and the bathroom needs very careful attention in order to satisfy the requirements of privacy and quiet adequately.

(4) Suites of different sizes offer opportunity for variety and flexibility.

(5) Members of an individual suite may become too self-contained in their social relationships unless a range of common spaces such as lounges, hobby and game areas and group study are related to the suites.

f. Apartments

(1) Single student apartments sized for 3 to 6 students seem best. More students make the cooking chore a nuisance.

(2) Apartments seem most appropriate for upper division and graduate students.

(3) Married student apartments should provide a range from one to three bedroom units plus specific provisions for quiet study.

2. Student Bath Facilities

a. Gang bathrooms

The social value of large bathrooms is often quoted. This allegation perhaps reflects experience with a lack of other suitable meeting spaces.

The construction economies of the gang bath versus smaller unit baths cannot be assumed as proven at this time. Larger

(D2. Student Bath Facilities continued)

yearly operations and maintenance costs per student of gang baths may more than offset any per student lower capital costs.

b. Small bathrooms

The University of California Standing Committee for Residence Halls has recommended provision of small bathrooms for 4 to 10 students. One of the technical aims of the URBS project will be to enable this to be done economically.

3. Student Social Spaces

a. Lounges and living rooms

Large lounges, as traditionally designed and located, do not fulfill the needs of the house groups. Furthermore, the costs of such lounges are high in relation to their utility. Several smaller spaces are required, each devoted to specific use.

b. Date rooms

The date room is an artificial solution to needs better met by a wider range of types of spaces.

4. Student Recreational Spaces

a. Facilities are necessary for familiar popular activities (ping pong, T.V., pool, etc.). A range of unallocated recreational spaces will provide facilities for special interest groups.

b. Use of the roof for recreational purposes is highly desirable, if appropriate to the general building design.

5. Student Cultural Spaces

Some quiet common spaces for reading or serious music listening are desirable.

6. Student Eating Spaces

a. Dining rooms

There is general agreement that a single large dining room is not satisfactory. Large space should be made divisible with adequate acoustical barriers, or groups of smaller dining spaces should be provided. This would not preclude the formal meal for a large group which has social values.

b. Snack spaces

Vending machines are an acceptable solution, though not as good as manned snack service. The latter needs a large student residence complex to be economically feasible.

(D6. Student Eating Spaces continued)

c. Room, suite and apartment facilities

Facilities which enable students to make their own tea or coffee are desirable.

The hot plate and refrigerator bring the need for clean-up facilities. The arrangement then becomes a minimal kitchen, which is expensive.

7. Student Academic Spaces

a. Study rooms

Study rooms are most useful for small group study. These rooms can be used for seminars or small group dining at other times if so designed.

b. Carrels

The study carrel has its optimum use if allocated to one student only. The specially equipped carrel (e.g., language laboratory) must be shared to be economically feasible.

The carrel has a place in the student residence, particularly for graduate students. However, improvement in study facilities in student rooms will make carrels without special equipment less necessary.

c. Classrooms

There is much controversy as to whether classrooms are appropriate in residence halls. If needed, classrooms can be limited to first and second floors only.

8. Student Storage and Service Spaces

a. Storage spaces

Storage space requirements tend to increase as students become more affluent. Space must be provided for bulky equipment such as luggage, surf boards, skis, phonograph, tape recorder, and bicycle.

b. Service spaces

Rooms for laundry and mechanical equipment require extensive utility services. Other service areas requiring special provisions are mail, linen, trash, building supply, and the like. All such spaces must be appropriately located as to traffic patterns both within and outside the building.

(D. Spatial Arrangements continued)

9. Circulation Spaces

a. Stairs

Stairs are important in determining social hierarchy patterns. URBS project will develop stairs as part of the structural system.

b. Elevators

Elevators tend to inhibit social interaction between floors. At least one elevator (for freight usage) is desirable even in low-rise buildings.

Technical problems are primarily those of maintenance and control. Present elevators are vulnerable to student pranks.

c. Corridors

The corridor is a source of noise. A long corridor has an unattractive, institutional appearance. Attention should be paid to good lighting, good acoustic absorption, stimulating color, and adequate ventilation.

E. SPACE UTILIZATION

1. Space Allocation

The basis of space allocation should be the single room whether or not it is used as such. This will afford the optimum flexibility.

2. Volume

Nominal eight-foot height for a student room is a reasonable standard. Volumes of different character on the top floor of buildings are desirable.

3. Form

URBS system will be basically rectilinear, but will allow for irregular building plans and room configurations.

4. Student Room Dimensional Standards

Present rooms are too small. Recommended sizes are:

<u>Single Rooms</u>	<u>Assignable Square Feet</u>
a. minimum area	110 (with minimum width of 8 feet clear)
b. desirable area	120 (with minimum width of 8 feet clear)

(E4. Student Room Dimensional Standards continued)

<u>Double rooms without bunked beds</u>	<u>Assignable Square Feet</u>
a. minimum area	180
b. desirable area	220
c. generous area	240

The amount of floor area required for circulation within a residence hall (stairs, elevators, corridors) varies with the basic design. Circulation areas should be minimized in order to maximize the assignable space.

Area allocations have ranged from 219 to 247 gross square feet per student including dining and kitchen. This area should be increased to 259 gross square feet per student to permit optimum interpretations of student environment as inferred from the user requirements study. This figure derives from the minimum 110 assignable square foot single room basis for each student, plus a slight increase in kitchenette and student storage areas.

5. Equipment

The above defined areas provide for a variety of satisfactory furniture arrangements.

a. Casework

Requirements for student storage within the rooms are growing. Casework should be movable.

b. Furniture

Beds should be movable. A small soft chair for use in student rooms is necessary. Present desks tend to be too small. There should be a possibility of some student-furnished items of furniture.

c. Personal appliances

There is a great increase in the number and type of small appliances which are available. These create storage and, in some cases, power and safety problems.

PART II. PROGRAMMING AND DESIGN

As already indicated the studies under Phase I of the project produced a variety of user requirements. Visits to campuses and to existing residence halls revealed many problems that might be helped or overcome in the new halls now being planned prior to those that will be built under the URBS program.

The summaries in this part of the report have been made to assist those now programming new halls and to serve partially as a transition between Phase I (User Requirements) and Phase II (Performance Specifications) of the URBS project.

Programming

A. SPECIFIC MAINTENANCE PROBLEMS--EXISTING HALLS

The most common problems with design in present student residences are:

1. Heavy solid core doors break wall materials adjacent to the door frames.
2. Walls in corridors and game rooms are too easily damaged from horseplay.
3. Metal shower partitions deteriorate rapidly.
4. Ventilation in shower rooms is inadequate.
5. Shower room floors and walls leak.
6. Elevators are abused and hard to maintain.
7. Low soft ceilings are abused.
8. Hardware fails on sliding closet doors.

B. ACADEMIC USE

Faculty-student involvement in residence halls is a major point of controversy. The inclusion of academic facilities is seen by some as a means of breaking down the impersonality of large institutions such as the University of California.

There is little enthusiasm for heavy academic involvement in the University's residence halls, with the exceptions at Santa Cruz, and to a lesser degree at San Diego and Riverside. Involvement, if it comes, will apparently be slow.

(B. Academic Use continued)

1. Some faculty are interested in having space in the residence hall for seminar type activities, provided the addition of such academic area as this does not isolate them from their departments.
2. It is very desirable to have effective faculty-student contact at meal times.
3. Conversion from residential to academic use is a consideration. Student rooms might readily be converted to faculty offices or seminar spaces.
4. Classroom facilities differ from recreation, social or living spaces in respect to heating and ventilation requirements.
5. If academic activities are brought into the residence hall, it is preferable they serve only the residence hall students.

C. STUDY AND COMMUNICATIONS

1. Studying is a complex activity, and the student has many ways of doing it. Eighty per cent of studying is done in the student's room. The bed is used as a study location as much as the desk.
2. Advances in electronic engineering are having an impact on the student's life; the impact is difficult to predict. New devices such as teaching machines and computers affect his academic life, and personalized equipment affects his recreational, social and cultural life.

Computer terminals, educational television for remote instruction, and remote retrieval of material from the library or campus lectures provide for a substantial range of educational possibilities within the residence hall.

Trends in electronic and audio-visual equipment point to an increasing individualization of use, so that it appears it will become increasingly unnecessary to summon students together in large numbers.

However, little experience is available on the effect of working with these new tools.

D. MANAGEMENT ITEMS

1. Control and Regulation

The URBS project aims to reduce the need for regulations stemming from building characteristics. Some of these result from material limitation, others may be the result of design: e.g., long double-loaded corridors result in regulations to reduce noise.

(D. Management Items continued)

2. Administration

- a. Financial incentives to encourage operating efficiency should be studied.
- b. Flexibility in URBS buildings will call for careful coordination with administrators if various possibilities are to be exploited.

3. Conference Use

- a. The income derived from conference use can be of considerable help to the residence hall financial program.
- b. The advent of the four-quarter system may affect conference uses of residence halls.

4. Maintenance

- a. Maintenance is a recurring operation that requires time and labor. It is a function of materials, manufacturing standards, installation methods and use. Maintenance on materials and mechanisms is usually grouped into the following five categories in maintenance contracts and manuals:
 - (1) Cleaning
 - (2) Refinishing
 - (3) Servicing
 - (4) Repairing
 - (5) Replacing
- b. Different systems of a building deteriorate at different rates and both design and materials should recognize this. Systems may become obsolete for technical, social and aesthetic reasons.
- c. Study needs to be done on comparisons between cheap, easily replaceable materials and more expensive, longer lasting materials as a solution to long-term maintenance costs.
- d. Maintenance contracts can assist in predicting and controlling costs. The fullest effectiveness of the maintenance contract applies when it is allowed to be a part of the bid process whereby equipment is selected in the first instance. The time period for the contract needs to relate to the specific equipment and to the contractual desires and capabilities of the owner.

Design

A. DESIGN PROCESS

1. The influence of URBS on architectural design will be in two primary areas.
 - a. Prices on the components are fixed so that estimating can be done with much greater accuracy.
 - b. Planning will be affected by the modules and spans of the selected structural system.
2. The fundamental procedures and responsibilities will remain unchanged from traditional practice. Working drawings and specification preparation by the architect will be simplified however, by his ability to incorporate directly into his own documents those elements prepared as part of the systems phase of the project.
3. The use of a building system will speed the construction process, particularly if effective University-wide scheduling can permit coordinating several campus jobs for the most efficient flow of labor and material from the component manufacturers.

B. ELEMENTS OF DESIGN

1. The use of a building system will in no significant way affect the architectural planning of the student residences. The size of the buildings will be unaffected. Story heights are expected to group around two to four stories and eight to twelve stories, but any number in that range will be available.
2. The project will not concern itself with exterior materials.

C. MODES OF FLEXIBILITY

Flexibility will be one of the key goals in the design of the components used in the URBS system. The quicker the change process, the more value to the student.

1. Immediate change through rearrangement

This is flexibility created by movable furniture, operable walls, movable space dividers.

2. Immediate change through subdivision

This applies more to public rooms. The utilization of operable walls reduces or increases the size of spaces.

(C. Modes of Flexibility continued)

3. Change through demountability

Demountable partitions, which are more difficult to move than operable walls, define plans of greater permanence. The concept of demountability requires that the cost of the operation itself does not become the major factor. The higher the requirements for acoustic separations and for ease of demounting, the higher the cost.

For the URBS project partitions would be moved primarily by custodians or professionals.

The ability to change the facilities may permit a traditionally operated student residence to evolve into a residential college. It might, in turn, permit the opposite to take place. However, the range of options cannot be infinite, and must be decided by the campus when the building program is written. The building then becomes a laboratory for its own evolution with opportunities to try different types of space utilization and to learn from experience.

4. Changes in services

Sufficient flexibility should be obtained by programming without the necessity for moving plumbing services. It should be possible to add kitchen units to convert suites to apartments. It should be possible to exchange a water closet for a urinal, and a shower for a bathtub.

PART III. PERFORMANCE SPECIFICATIONS

Performance specifications will be prepared to translate as many of the user requirements as possible into a set of instructions or definitive statements to guide industry in the design and manufacture of a particular building component. These same specifications will form the basis of evaluating the proposals submitted by various manufacturers for the different components.

The problem of maintenance will be an important consideration in the performance specifications and in the later evaluation of the bid proposal. For example, those parts of a heating, ventilating and air conditioning system that are known to produce high maintenance costs must be defined so that they may be replaced as self-contained units. The manufacturers will probably be asked to bid an alternate that would provide not only the initial units but also full maintenance on a 20-year and a 40-year basis. The discussions with representative manufacturers to date indicate this to be entirely feasible.

A. PERFORMANCE SPECIFICATIONS--THE APPROACH

Components to be used in the URBS project will be selected on the basis of bids received on performance specifications. This type of specification describes the problem to be solved, rather than the materials and methods of solution. The purpose is to enable manufacturers to bring their special expertise to bear on the solution of problems, and to increase the scope of solutions offered. In the traditional specification procedure, decisions as to systems, components, and material are made at the initiation of design, and the problems are not presented to manufacturers.

For example, a traditional specification may be based on a prior decision to use a prestressed concrete structure which is then drawn up and described in detail; however, only manufacturers of prestressed concrete are involved in the solution. By contrast the URBS structure specification describes the necessary spans, loads, and configurations to be provided. Limitations imposed by codes and the coordination of other components are also noted, and this leaves the solution open to specialists in concrete, steel, wood, or any combination of materials.

The URBS family of components (representing 50-60% of the total building costs) will consist of the structural system (above the grade line); heating, ventilating and air conditioning system; student bathrooms; the partitions; and the casework and furniture. (Other systems, e.g., electrical, are not included because of special problems.) Performance specifications are being drafted for the selected systems.

B. PERFORMANCE SPECIFICATIONS--THE ANALYSIS

1. Structure-Ceiling System

The aim is to provide a structure specially designed to meet the needs for variety and flexibility in future University of California student residences.

(Bl. Structure-Ceiling System continued)

The system will include the floor component, columns, stairways, and the roof. A depth of 12" to 36" will be allowed in the floor component with an added cost consideration for all solutions requiring more than 12". The ceiling may be exposed structure or a hung material.

To ensure individuality in the exterior designs, the exterior walls will not be a part of the system, so may be of any material desired. Further, the roofs may be flat as part of the system or sloped, which would be non-system.

The structural system must permit planning of the various structures in any variety of configurations the architect may choose.

In order to achieve the flexibility required by changing spatial needs within the residence halls, it was determined by extensive study that up to 40'-0" maximum spans between outside walls would be needed. A 20" structural planning module has been adopted.

2. Heating, Ventilating and Cooling System

The primary aim of the mechanical system is to produce thermal conditions particularly appropriate to student requirements.

The three most critical requirements (aside from high standards of thermal and acoustic performance, control and dependability) are:

- a. The equipment shall maintain the specified standards of operation regardless of the manner in which floor plans are rearranged by means of demountable partitions.
- b. The allowable locations for placement of terminal devices have been carefully restricted in order to accommodate the free movement of furniture within the student room.
- c. All student living quarters, and most other occupied spaces, will have operable sash. The opening of windows and doors must not disturb the efficient and satisfactory operation of equipment.

The successful bidder will be nominated on the basis of in-place cost, plus estimated operating cost, plus the cost of a long-term maintenance contract, after it has been determined that the proposed system can meet all specified performance criteria. The long-term maintenance contract will be available to individual campuses as an option.

3. Bathroom Units

The object of the bathroom units is to provide the student with facilities which can be regarded as "residential" rather than "institutional." The approach will be to use small baths.

(B3. Bathroom Units continued)

The possible resulting increased plumbing costs will be offset in two ways:

- a. The expense of cleaning can be eliminated or markedly reduced through reliance on the students themselves. The University of California Standing Committee on Residence Halls supports this.
- b. Present construction inefficiency will be reduced through the specifying of bathrooms as standardized units.

Specific areas receiving attention are:

- a. The thermal, acoustic and lighting environment, and odor and humidity control.
- b. The relation of the bath unit to other components of the building system to facilitate rapid and carefully scheduled building procedures.
- c. The design of a satisfactory watertight enclosure.
- d. The configurations of all fixtures, fittings, accessories and room interior details, as well as their surfaces and joining characteristics. These items include:
 - (1) Conformation to current knowledge of physiology and use patterns, rather than conventional dimensional standards.
 - (2) Maximum ease of maintenance and repair.
 - (3) A modular set of components giving architectural planning flexibility with the minimum number of different parts.

4. Partition System

The aim is to provide a range of fixed and demountable partitions permitting variety, flexibility and individuality in room configurations. A range of interchangeable surfaces specifically designed for student requirements will be provided, including chalk and tack boards.

The normal planning module is 20", with panels provided in 20", 40" and 60" widths. The vertical module is 2 feet, from 8 feet through 16 feet. The maximum thickness of partitions is 4" for those less than 12 feet in height.

All panel types must provide a degree of impact resistance appropriate to student residence use. They must be resistant to all common usages. Panels which are damaged will be repairable in the field. All partition components will be incombustible. Partition acoustical performance will match or exceed the best currently

(B4. Partition System continued)

available within the University system. The door, the weakest link in partition acoustical performance, will offer substantially improved sound isolation.

A system of demountability will be provided so the spaces may be changed as requirements evolve. Demountability must be readily accomplished by campus maintenance personnel, but not by the residents, to meet exit requirements and assure control.

5. Furniture System

The aim is to provide a range of attractive, rugged, movable furniture which will permit the student maximum variety of arrangement. The furniture will be designed to answer the special needs of the student in his study and living patterns.

All components will be relocatable whether they are free-standing or require structural support from the partitions.

Four basic units are provided to support interchangeable drawers and doors, shelves and accessories forming chests, dressers, wardrobes, and closets.

Two desk sizes are called for. They may be wall hung or free-standing.

Beds, 3 feet wide by 7 feet in length, will be provided in two types: a bunkable single and a bolster day-bed.

A desk chair and a small easy chair are needed with standards of comfort, durability, and low cost beyond what has previously been available.

A screen for use by the students in sub-dividing the space assigned to them will be provided.

Furniture components are required to provide the same standards of surface durability as the partitions.

There are minimum material standards covering wood, plywood, metal and several plastics.

PART IV. PERFORMANCE GRADING

The initial cost is too often the only or principal item of consideration in the evaluation of a building. At least two more items should be given careful consideration: (1) how well does the building and its components satisfy the user needs, and (2) what are the expected operation and maintenance costs during the expected life of the building, particularly during the repayment of the loan.

In the case of most student housing projects, the repayment period is 40 years, selected primarily to reduce the annual debt service and in turn keep the board and room rates as low as possible. Obviously, maintenance costs during the 40-year life of the building are an important consideration.

There is little information available that relates maintenance costs to type of construction. Approximately 2½ years ago the cost system of the University of California residence halls was revised to produce better management data. Some information is now becoming available that indicates what the maintenance costs are for different elements and different areas in the various residence halls.

Building components that afford reductions in operating costs will provide alternatives that permit either a reduction in room rates or a greater satisfaction of user requirements. A reduction in operating costs of \$1.00 per year per student would permit an increase of \$15 in initial capital investment without a change in the room rates.

From actual inspection of many residence halls coupled with the interviews with many people in connection with the User Requirements studies, there is little doubt that considerable savings in operation and maintenance costs can be effected by using building components with high performance standards. It would seem desirable that there be flexibility in the ratio of capital and operating costs so that each campus might have some choice in its programming. In some instances, units may be desired with relatively large space allotments and higher capital costs but with minimal operating costs. The reverse may be equally desired. In still another instance, both capital and operations costs might be reduced, as in cooperative-type facilities. In any event, each campus could be provided with incentives by which to select whatever variables would suit its needs, accept the responsibilities for meeting the associated cost budgets, and establish the room rates commensurate with the cost of the variables selected. The financial flexibility suggested would be needed to accommodate the great variety of user requirements for which the URBS system will be designed.

In the charts that follow, an attempt has been made to devise a system of rating a building as to its performance--first as to how well it satisfies user requirements in items related to capital costs, and second as to what the expected rating might be in items related to maintenance and operations. Three examples are used:

1. A reinforced concrete residence hall (Residence Hall A in Part V of this report).

2. A wood frame residence hall (Residence Hall D in Part V of this report).
3. A residence hall to be built under the URBS program, using a family of components with specified performance standards.

On the first page for each example certain physical properties and characteristics of a building have been listed along with appropriate nomenclature to describe each. The shaded areas indicate the appropriate description and grading of the building named in the title. All of the elements listed on this page relate to initial design and to capital outlay costs.

The second page of each example is an attempt to evaluate the same building in relation to certain maintenance and operations items that are measurable and for which cost data can be derived from the present cost reporting system.

Although these studies have just begun, the results thus far indicate a promising method to evaluate how well a building is satisfying user requirements and what correlation exists between initial design and operating costs.

Obviously any system of components must be compatible if maximum effectiveness is to be achieved. For instance, in the two examples used the sound insulation in the walls and floors (items 6 and 7) are very good (perhaps better than need be), but is largely negated by the poor rating of sound insulation in the door (item 8). In many of the halls visited but not represented by the examples in this summary report, acoustical treatment had been adequately handled within the room itself, but through the ducts of the heating and ventilating system the rooms have become connected to a fairly efficient communication system for the entire hall.

PERFORMANCE GRADING FOR RESIDENCE HALL A - page 1 of 2
(ITEMS RELATED TO CAPITAL OUTLAY)

a	NUMBER OF STORIES	1	2	3	4	5	6	7	8	9	14
b	CEILING HEIGHT (Feet)	9	10	11	12	13	14	15	16		
c	CRITICAL SPANS (Feet)	0-5	5-10	10-15	15-20	20-25	25-30	30-35	35-40	40-45	45-50
d	FLOOR LIVE LOADINGS (Pounds per square foot)	40	50	60	70	80	90	100			
e	TYPE OF CONSTRUCTION	V	III	III-1 hour	IV	IV-1 hour	II	I			
f	WALL SOUND INSULATION (Sound Transmission Class)	0-10	10-15	15-20	20-25	25-30	30-35	35-40	40-45	45-50	
g	FLOOR SOUND INSULATION (Sound Transmission Class)	0-10	10-15	15-20	20-25	25-30	30-35	35-40	40-45	45-50	
h	DOOR SOUND INSULATION (Sound Transmission Class)	0-10	10-15	15-20	20-25	25-30	30-35	35-40	40-45	45-50	
i	GENERAL ILLUMINATION (Foot candles)	20	30	40	50	60	70	80	90	100	
j	DESK ILLUMINATION (Foot candles)	20	30	40	50	60	70	80	90	100	
k	TEMPERATURE CONTROL	Bldg.	Floor	Orient'n	Room						
l	HEATING, VENTILATING, AIR CONDITIONING	Heat	Heat, Vent	Heat, Cool	Heat, Vent, Cool						
m	ROBUSTNESS	1	2	3	4						
n	FINISHES	1	2	3	4						
o	LIGHTING FIXTURES (Per double room)	1	2	3	4						
p	DUPLEX OUTLETS (Per double room)	1	2	3	4						

* 1 - Weak, easy to damage, annual care required.

2 - Susceptible to damage with rough treatment.

3 - Hard to damage, difficult to repair.

4 - Resistant to damage

BSDI

11-1-66

PERFORMANCE GRADING FOR RESIDENCE HALL A - page 2 of 2
(ITEMS RELATED TO MAINTENANCE AND OPERATIONS)

a	MAINTENANCE - ROOFING	A-1	A-2	A-3	A-4
b	MAINTENANCE - WALLS	A-1	A-2	A-3	A-4
c	MAINTENANCE - CEILINGS	A-1	A-2	A-3	A-4
d	MAINTENANCE - FLOOR	A-1	A-2	A-3	A-4
e	MAINTENANCE - UTILITIES	A-1	A-2	A-3	A-4
f	MAINTENANCE - EQUIPMENT	A-1	A-2	A-3	A-4
g	MAINTENANCE - FURNISHINGS	A-1	A-2	A-3	A-4
h	OPERATIONS - UTILITY USAGE	B-1	B-2	B-3	B-4
i	OPERATIONS - CLEANING PUBLIC AREAS	C-1	C-2	C-3	C-4
j	OPERATIONS - CLEANING STUDENT ROOMS	C-1	C-2	C-3	C-4
k	OPERATIONS - CLEANING TOILET ROOMS	C-1	C-2	C-3	C-4
l	ADMINISTRATIVE COSTS (Operations and Maintenance)	B-1	B-2	B-3	B-4

A. 1 - Care, repair and replace beyond normal. 3 - Susceptible to damage or malfunction under heavy use.
2 - Susceptible to damage or control malfunction 4 - Good performance

B. 1 - Wasteful
2 - Heavy
3 - Medium
4 - Light

C. 1 - Daily, frequent professional cleaning.
2 - Weekly
3 - Monthly
4 - Term

BSDI
11-1-66

PERFORMANCE GRADING FOR RESIDENCE HALL D - page 1 of 2
(ITEMS RELATED TO CAPITAL OUTLAY)

a	NUMBER OF STORIES	1	2	3	4	5	6	7	8	9	14
b	CEILING HEIGHT (Feet)	8	9	10	11	12	13	14	15	16	
c	CRITICAL SPANS (Feet)	0-5	5-10	10-15	15-20	20-25	25-30	30-35	35-40	40-45	45-50
d	FLOOR LIVE LOADINGS (Pounds per square foot)	40	50	60	70	80	90	100			
e	TYPE OF CONSTRUCTION	I	III	III - 1 hour	IV	IV - 1 hour	II	I			
f	WALL SOUND INSULATION (Sound Transmission Class)	0-10	10-15	15-20	20-25	25-30	30-35	35-40	40-45	45-50	
g	FLOOR SOUND INSULATION (Sound Transmission Class)	0-10	10-15	15-20	20-25	25-30	30-35	35-40	40-45	45-50	
h	DOOR SOUND INSULATION (Sound Transmission Class)	0-10	10-15	15-20	20-25	25-30	30-35	35-40	40-45	45-50	
i	GENERAL ILLUMINATION (Foot candles)	20	30	40	50	60	70	80	90	100	
J	DESK ILLUMINATION (Foot candles)	20	30	40	50	60	70	80	90	100	
k	TEMPERATURE CONTROL	Bldg.	Floor	Orient'n.	Room						
l	HEATING, VENTILATING, AIR CONDITIONING	Heat	Heat, Vent	Heat, Cool	Heat, Vent, Cool						
m	ROBUSTNESS	*	2	3	4						
n	FINISHES	*	2	3	4						
o	LIGHTING FIXTURES (Per double room)	1	2	3	4						
p	DUPLEX OUTLETS (Per double room)	1	2	3	4						

* 1 - Weak, easy to damage, annual care required.
2 - Susceptible to damage with rough treatment.
3 - Hard to damage, difficult to repair.
4 - Resistant to damage.



PERFORMANCE GRADING FOR RESIDENCE HALL D - page 2 of 2
 (ITEMS RELATED TO MAINTENANCE AND OPERATIONS)

a	MAINTENANCE - ROOFING	A-1	A-2	A-3	A-4
b	MAINTENANCE - WALLS	A-1	A-2	A-3	A-4
c	MAINTENANCE - CEILINGS	A-1	A-2	A-3	A-4
d	MAINTENANCE - FLOOR	A-1	A-2	A-3	A-4
e	MAINTENANCE - UTILITIES	A-1	A-2	A-3	A-4
f	MAINTENANCE - EQUIPMENT	A-1	A-2	A-3	A-4
g	MAINTENANCE - FURNISHINGS	A-1	A-2	A-3	A-4
h	OPERATIONS - UTILITY USAGE	B-1	B-2	B-3	B-4
i	OPERATIONS - CLEANING PUBLIC AREAS	C-1	C-2	C-3	C-4
j	OPERATIONS - CLEANING STUDENT ROOMS	C-1	C-2	C-3	C-4
k	OPERATIONS - CLEANING TOILET ROOMS	C-1	C-2	C-3	C-4
l	ADMINISTRATIVE COSTS (Operations and Maintenance)	B-1	B-2	B-3	B-4

A. 1 - Care, repair and replace beyond normal. 3 - Susceptible to damage or malfunction under heavy use.
 2 - Susceptible to damage or control malfunction 4 - Good performance.

B. 1 - Wasteful 3 - Medium
 2 - Heavy 4 - Light

C. 1 - Daily, frequent professional cleaning. 3 - Monthly
 2 - Weekly 4 - Term

BSDI
 11-1-66

PERFORMANCE GRADING FOR URBS SPECIFICATION - page 1 of 2

(ITEMS RELATED TO CAPITAL OUTLAY)

a	NUMBER OF STORIES	1	2	3	4	5	6	7	8	9	14
b	CEILING HEIGHT (Feet)	8	9	10	11	12	13	14	15	16	
c	CRITICAL SPANS (Feet)	0-5	5-10	10-15	15-20	20-25	25-30	30-35	35-40	40-45	45-50
d	FLOOR LIVE LOADINGS (Pounds per square foot)	40	50	60	70	80	90	100			
e	TYPE OF CONSTRUCTION	V	III	III-1 hour	IV	IV-1 hour	II	I			
f	WALL SOUND INSULATION (Sound Transmission Class)	0-10	10-15	15-20	20-25	25-30	30-35	35-40	40-45	45-50	
g	FLOOR SOUND INSULATION (Sound Transmission Class)	0-10	10-15	15-20	20-25	25-30	30-35	35-40	40-45	45-50	
h	DOOR SOUND INSULATION (Sound Transmission Class)	0-10	10-15	15-20	20-25	25-30	30-35	35-40	40-45	45-50	
i	GENERAL ILLUMINATION (Foot candles)	20	30	40	50	60	70	80	90	100	
j	DESK ILLUMINATION (Foot candles)	20	30	40	50	60	70	80	90	100	
k	TEMPERATURE CONTROL	Bldg.	Floor	Orient'n.	Room						
l	HEATING, VENTILATING, AIR CONDITIONING	Heat	Heat, Vent.	Heat, Cool	Heat, Vent., Cool						
m	ROBUSTNESS	1	2	3	4						
n	FINISHES	1	2	3	4						
o	LIGHTING FIXTURES (Per double room)	1	2	3	4						
p	DUPLEX OUTLETS (Per double room)	1	2	3	4						

* 1 - Weak, easy to damage, annual care required.
 2 - Susceptible to damage with rough treatment.

3 - Hard to damage, difficult to repair.
 4 - Resistant to damage.



PERFORMANCE GRADING FOR URBS SPECIFICATION - page 2 of 2
 (ITEMS RELATED TO MAINTENANCE AND OPERATIONS)

a.	MAINTENANCE - ROOFING	A - 1	A - 2	A - 3	A - 4
b.	MAINTENANCE - WALLS	A - 1	A - 2	A - 3	A - 4
c.	MAINTENANCE - CEILINGS	A - 1	A - 2	A - 3	A - 4
d.	MAINTENANCE - FLOOR	A - 1	A - 2	A - 3	A - 4
e.	MAINTENANCE - UTILITIES	A - 1	A - 2	A - 3	A - 4
f.	MAINTENANCE - EQUIPMENT	A - 1	A - 2	A - 3	A - 4
g.	MAINTENANCE - FURNISHINGS	A - 1	A - 2	A - 3	A - 4
h.	OPERATIONS - UTILITY USAGE	B - 1	B - 2	B - 3	B - 4
i.	OPERATIONS - CLEANING PUBLIC AREAS	C - 1	C - 2	C - 3	C - 4
j.	OPERATIONS - CLEANING STUDENT ROOMS	C - 1	C - 2	C - 3	C - 4
k.	OPERATIONS - CLEANING TOILET ROOMS	C - 1	C - 2	C - 3	C - 4
l.	ADMINISTRATIVE COSTS (Operations and Maintenance)	B - 1	B - 2	B - 3	B - 4

A. 1 - Care, repair and replace beyond normal. 3 - Susceptible to damage or malfunction under heavy use
 2 - Susceptible to damage or control malfunction. 4 - Good performance

B. 1 - Wasteful 3 - Medium
 2 - Heavy 4 - Light

C. 1 - Daily, frequent professional cleaning. 3 - Monthly
 2 - weekly 4 - Term

BSDI
 11-1-66

PART V. COST STUDIES

In order to establish a realistic framework of cost data within which to analyze the proposed system of components, detailed cost studies have been undertaken on several existing residence halls in the University system. The studies on five of these buildings have been completed and illustrative results are reported herein to indicate the procedures being used.

The selection of buildings for inclusion in this report was made so as to include both high-rise and low-rise, reinforced concrete and frame construction (i.e., Type I and Type V), and other factors that represent a wide range of planning of residence halls in recent years. In all cases the halls are either fully completed or well along in construction; therefore actual cost figures are available and have been correlated with the quantities and costs of the contractors who built the buildings. All have been updated to the same cost index (January 1, 1966).

Studies thus far have included only the residential part of the housing program--not including the dining facilities. Such analyses do suggest, however, that assumptions regarding distribution of costs between living and dining facilities are in need of re-examination.

In the cost analyses, each of the five halls has been examined in detail in ten principal elements of a building. The cost of these elements varies greatly among the five buildings. But from these analyses it is possible to ascertain the range of costs of elements and thus establish a cost target for the new family of components.

A summary of the cost per student for each of the elements and in total for each hall is given in the following table:

Residence Hall Building Costs per Student by Building
(Exclusive of Dining and Kitchen Facilities)

<u>Building Element</u>	<u>Residence Hall</u>				
	A	B	C	D	E
1. Below Grade and Ground Floor	\$ 134	\$ 191	(\$ 353)	\$ 256	\$ 330
2. Floors	(1016)	640	967	696	668
3. Roof	170	176	221	(376)	231
4. Partitions	733	550	(955)	422	632
5. General - Mirrors, Closets, etc.	203	142	240	(352)	243
6. Exterior Skin	876	651	671	459	(959)
7. Plumbing	289	310	396	(501)	356
8. Heating & Air Conditioning	276	(839)	437	300	382
9. Electrical	215	194	249	(275)	254
10. Elevators	(243)	112	141	0	0
<u>Total Cost Per Student</u>	\$4155	\$3805	(\$4733)	\$3637	\$4055

() Highest Cost
 _____ Lowest Cost

Attention is called to the fact that the costs in the foregoing table are building costs, not project costs. The unit building cost per student, the building cost per gross square foot, the gross square feet per student, and the project cost per student are given in the following table, arranged in order of descending total cost.

Residence Hall Building and Project Costs
(Exclusive of Dining and Kitchen Facilities)

UNIT	Building Cost Per Student	Building Cost Per Gross Square Foot	Gross Square Feet Per Student*	Project Cost Per Student
C	\$4733	\$21.94	216	\$6250
A	4155	21.89	186	5300
E	4055	18.50	214	5341
B	3805	22.04	168	4900
D	3637	15.52	231	4700
			AVE. 203	AVE. \$5298

* Area adjusted to double room basis for all five halls.

In order that the reader may better understand the procedure used and the detail developed to arrive at the figures shown in the foregoing summary, there follows a detailed sheet for the high and the low cost residence halls for each of the ten building elements together with an explanation of these ranges in costs.

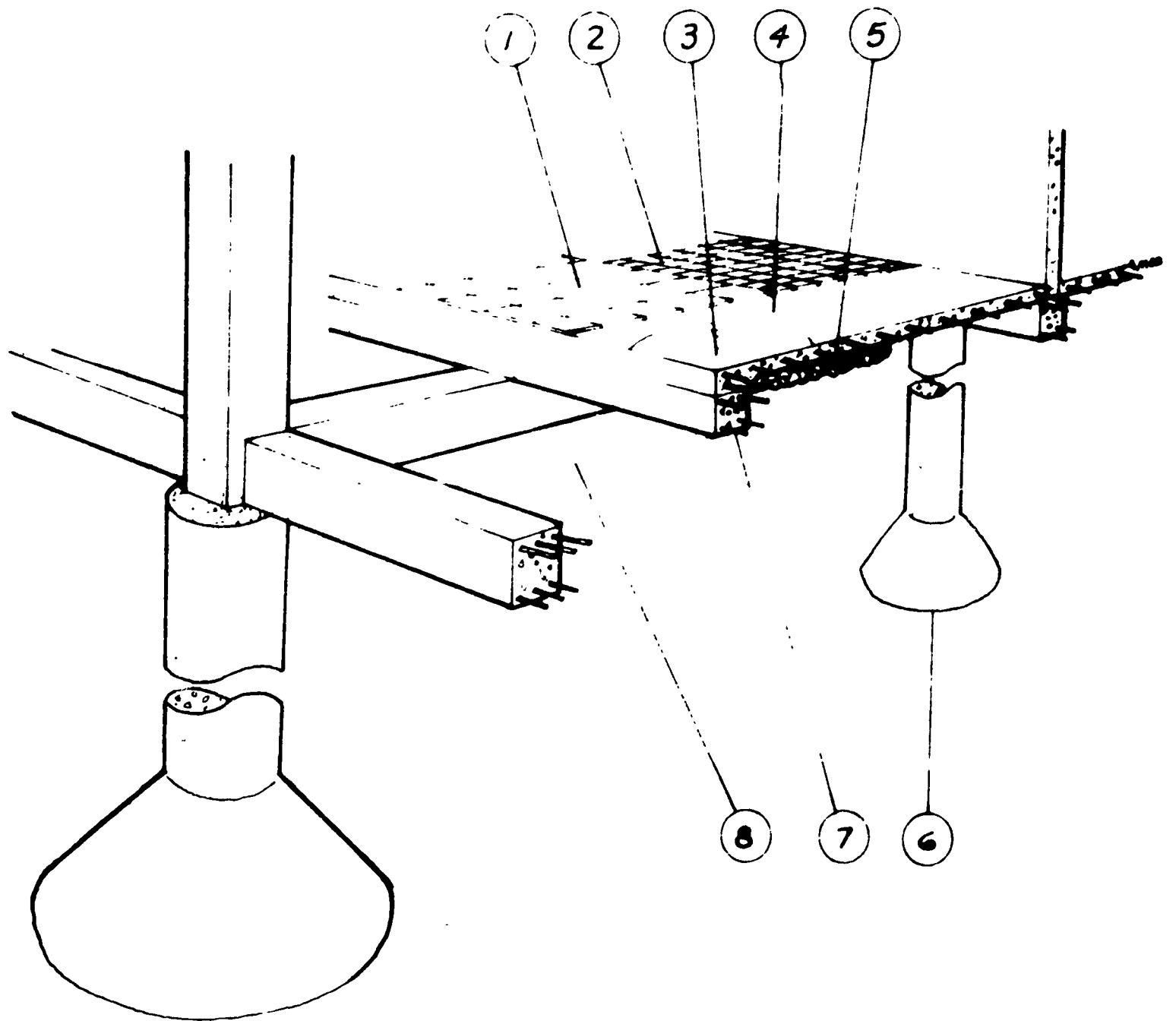

FIRST FLOOR:

1. VINYL ASBESTOS FLOOR	0.20
2. CERAMIC TILE FLOOR	0.06
3. CONCRETE SLAB	1.00
4. COLOR FINISH	0.05
5. GRAVEL BASE	0.11
	<hr/>
8800 sq. ft. = \$13,450.	1.53

BELOW GRADE:

6. CAISSONS	2.27
7. GRADE BEAMS	4.54
8. BUILDING EXCAVATION	0.28
	<hr/>
8800 sq. ft. = \$62,500.	7.09

\$353 per student resident

HIGH COST - ELEMENT No. 1, RESIDENCE HALL C

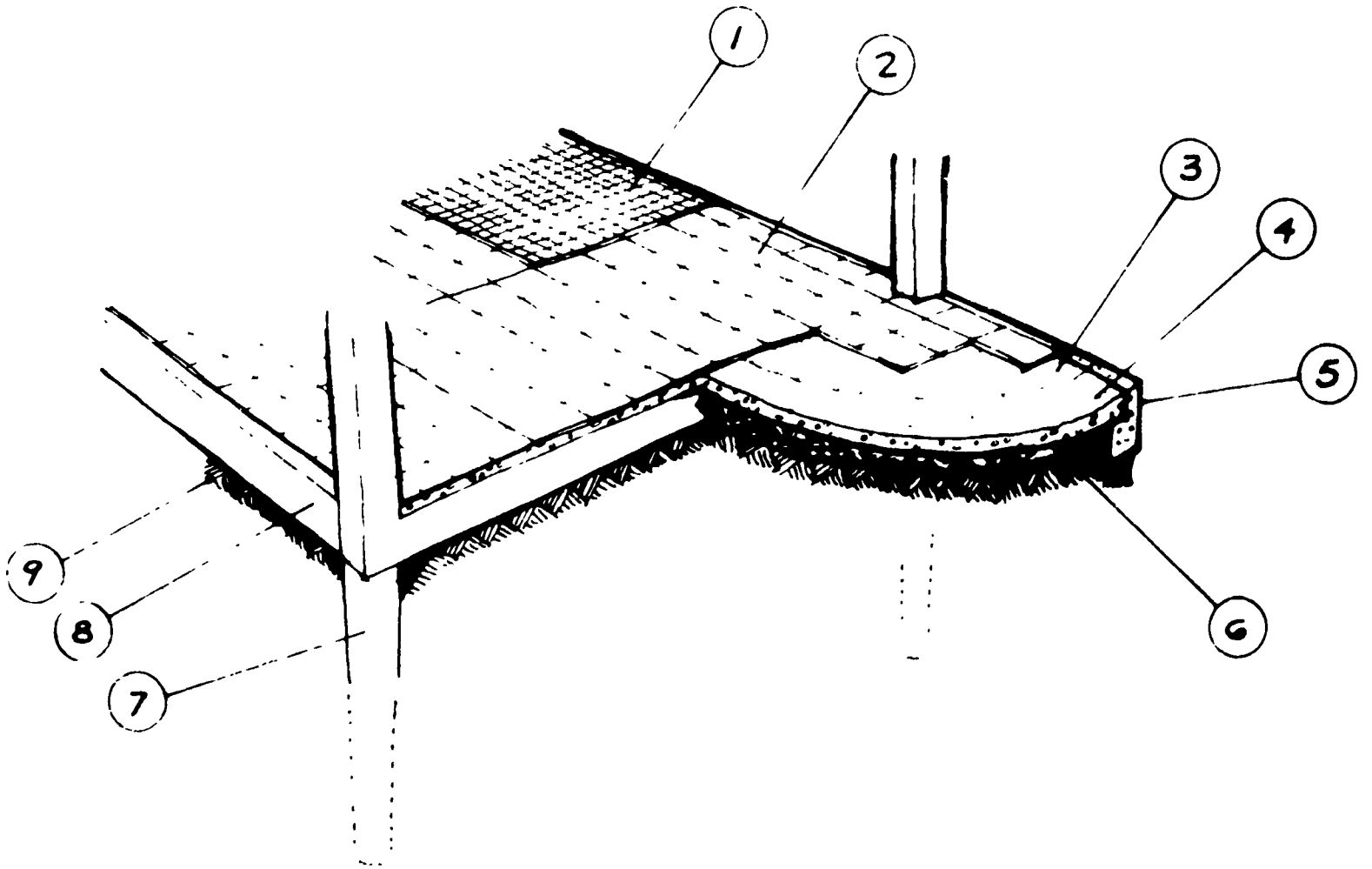

GROUND FLOOR:

1. CERAMIC TILE FLOOR & BASE.	0.31
2. VINYL TILE FLOOR	0.45
3. FINISH CONCRETE FLOOR	0.01
4. CONCRETE SLAB	1.00
5. CURB	0.11
6. GRAVEL BASE	0.09
4450 sq. ft. = \$8800.	<u>1.97</u>

BELOW GRADE:

7. POURED CONCRETE CAISSONS	4.49
8. CONCRETE GRADE BEAMS, ETC.	0.59
9. EXCAVATING, BUILDING	0.51
4450 sq. ft. = \$24,890.	<u>5.59</u>

\$134 per student resident

LOW COST - ELEMENT No. 1, RESIDENCE HALL A

COMPARISON OF HIGH AND LOW COST BUILDING ELEMENT NO. 1

1. Below Grade Construction

Building C is high in this category because of extensive bell caisson footings and a set back ground floor exterior wall requiring skewed grade beams of complicated design.

Building A is low because of a simple structural relationship to a direct foundation system, in this case poured concrete piles.

General: Barring unusually poor soil conditions, \$175 to \$220 per student resident is representative of current below-grade construction costs. In Type I construction greater height tends to reduce unit foundation costs. Type V (wood frame construction) foundations are usually determined by arbitrary code dimensions rather than by soil engineering calculations.

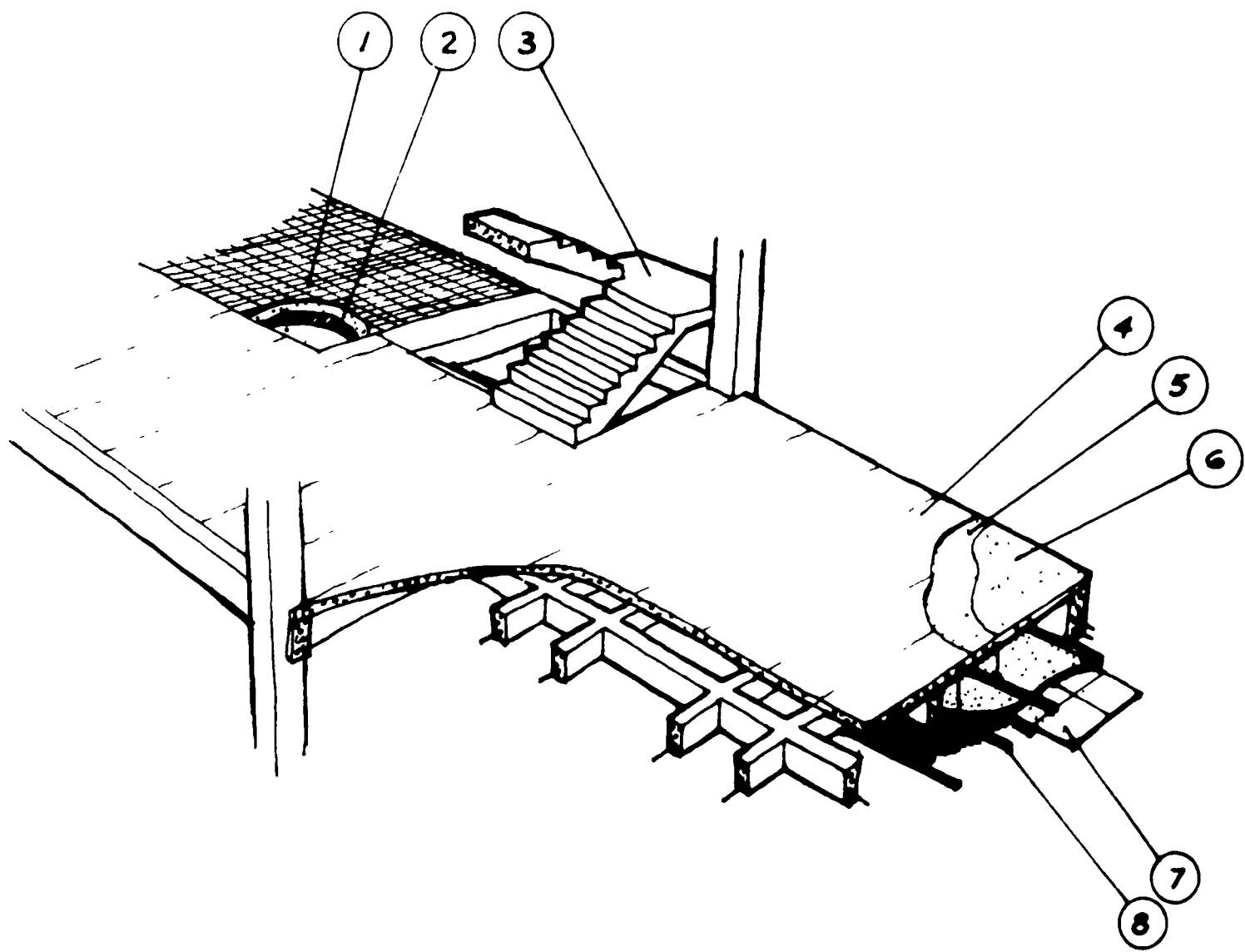

FIRST FLOOR:

1. CERAMIC TILE FLOOR	0.27
2. WATERPROOF MEMBRANE	0.04
3. CONCRETE STAIRS	0.43
4. LINOLEUM FLOOR	0.46
5. FINISH SLAB	0.14
6. CONCRETE BEAMS AND SLAB	2.55
7. ACOUSTIC CEILING TILE - 3/4"	0.68
8. HUNG METAL LATH & PLASTER	0.50
	<hr/>
	5.07

4630 sq. ft. = \$23,490.

\$1016 per student resident

HIGH COST - ELEMENT No. 2, RESIDENCE HALL A

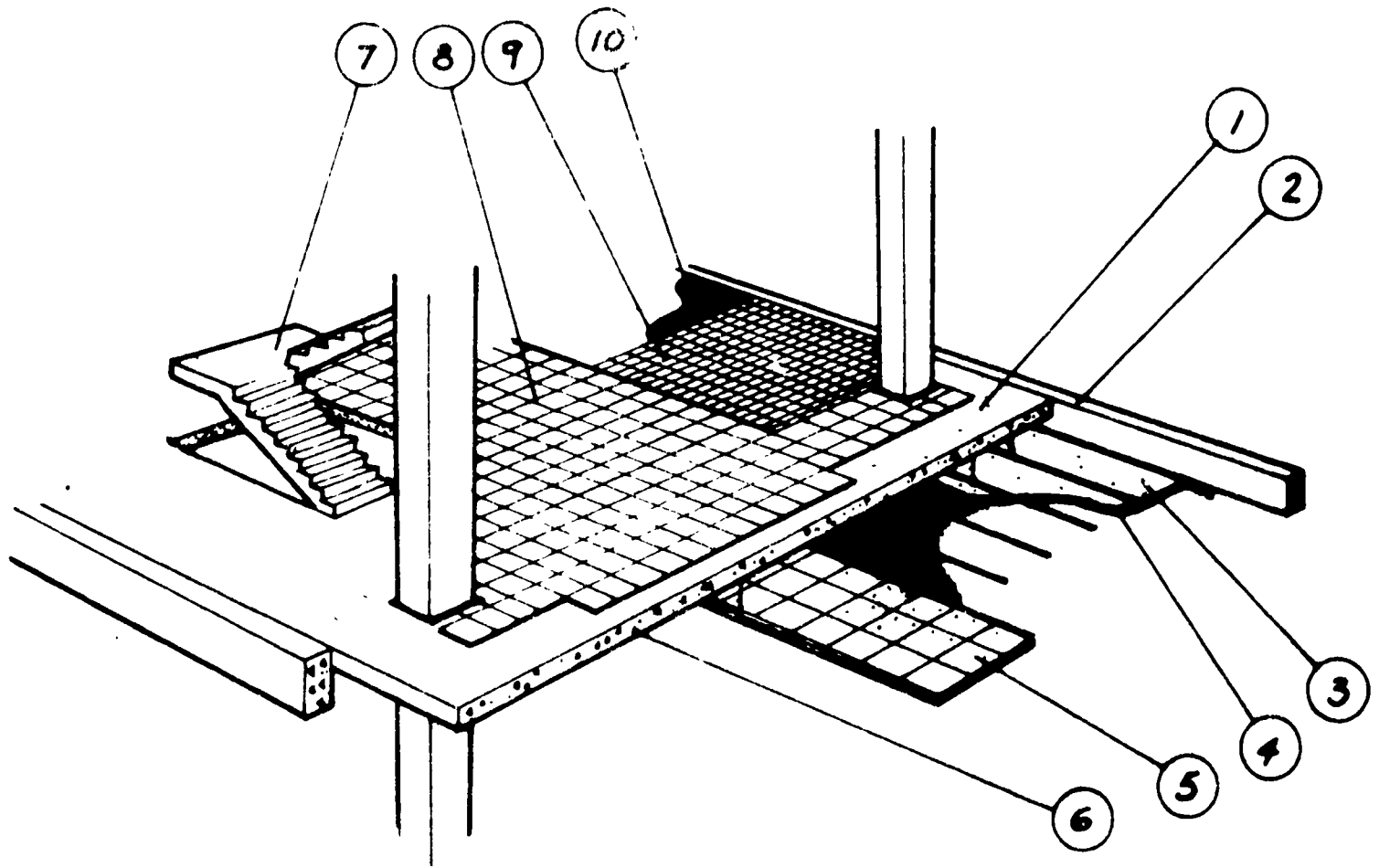

2nd, 3rd & 4th FLOORS:

1. CONCRETE LIFT-SLAB FLOOR	2.44
2. CONCRETE CURB	0.01
3. HUNG METAL LATH & PLASTER CEILING	0.14
4. PAINT HUNG CEILING	0.04
5. SUSPENDED ACOUSTIC TILE CEILING	0.20
6. PAINT EXPOSED CEILING	0.09
7. CONCRETE STAIRS	0.16
8. ASPHALT TILE FLOOR	0.24
9. CERAMIC TILE FLOOR	0.34
10. WATERPROOF MEMBRANE	0.05
	3.71

17,400 sq. ft. = \$64,430.

\$640 per student resident

LOW COST - ELEMENT No. 2, RESIDENCE HALL B

COMPARISON OF HIGH AND LOW COST BUILDING ELEMENT NO. 2

2. Floor System (complete horizontal system per floor)

Building A is high in this category because of a relatively large circulation-to-occupied-space ratio (small floor area per floor for a multi-story building) and an elaborate suspended ceiling system.

Building B is low as a result of effective use of a flat lifted concrete slab used also in large part as ceiling and a very efficient, though monotonous, circulation-to-bedroom pattern.

General: Representative cost of recent floor systems is \$270 to \$880 per student resident. Efficiency of floor area use and economy of construction detail appear to be prime determinants of cost. It is to be noted that in this category a Type I concrete structural system can be comparable in economy to that of the Type V buildings' wood frame construction.

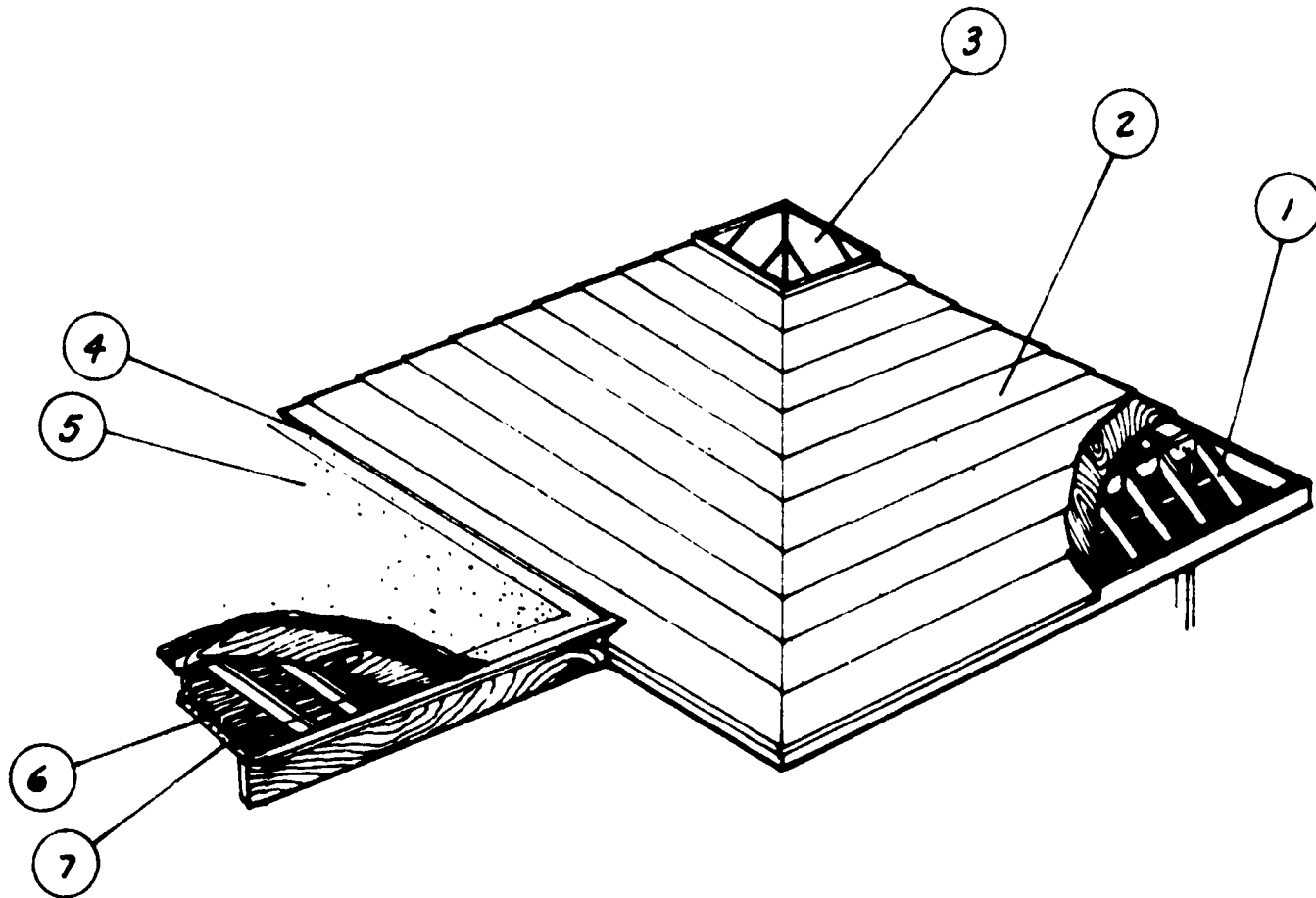

ROOF:

1. CEILING & ROOF FRAMING	0.96
2. BERMUDA ROOF	0.40
3. SKYLIGHTS	0.07
4. SHEET METAL	0.05
5. COMPOSITION ROOF	0.22
6. THERMAL INSULATION	0.14
7. PLASTER CEILING	0.36

57,000 sq. ft. @ 2.20 = \$125,570. 2.20

\$376 per student resident

HIGH COST - ELEMENT No. 3, RESIDENCE HALL D

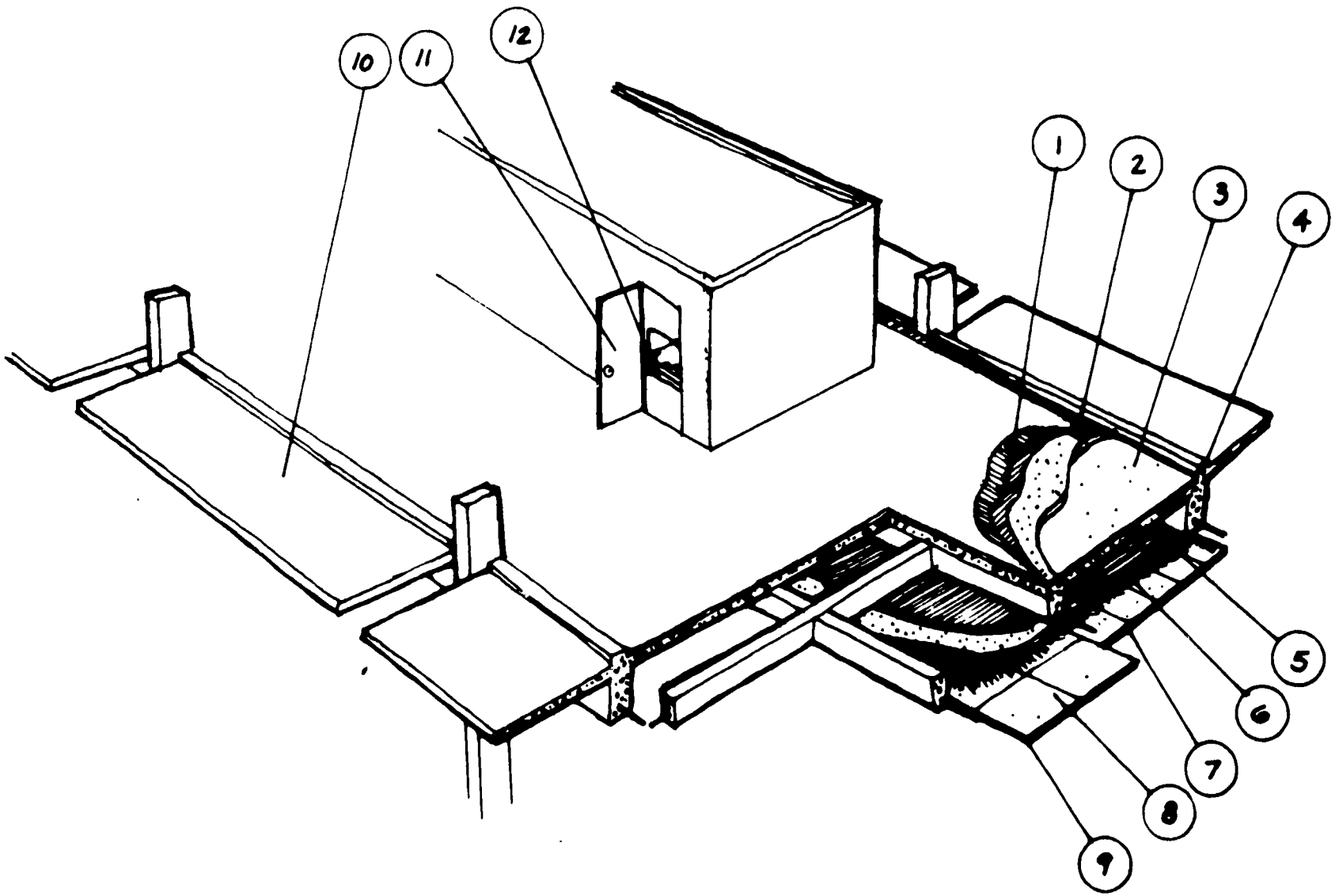

ROOF:

1. ROOFING	0.22
2. SHEET METAL	0.19
3. LIGHTWEIGHT FILL	0.36
4. CONCRETE SLABS, BEAMS, CURBS & PENTHOUSE	3.20
5. BLANKET INSULATION	0.13
6. SUSPENDED METAL LATH & PLASTER CEILING	0.38
7. ACOUSTIC TILE, FIBER	0.19
8. ACOUSTIC TILE, MINERAL	0.12
9. CEILING PAINT, ENAMEL	0.01
10. EXTERIOR PAINT, SHADES	0.07
11. HOLLOW METAL DOORS	0.16
12. CONCRETE STAIRS	0.07
6245 sq. ft. = \$31,785.	5.10

\$170 per student resident

LOW COST - ELEMENT No. 3, RESIDENCE HALL A

COMPARISON OF HIGH AND LOW COST BUILDING ELEMENT NO. 3

3. Roof System

Building D is high. This 2-story building has extensive overhangs and stresses the architectural character of its roofing, both in form and in materials.

Building A is low since its nine-story height requires small roof area per student housed.

General: Roof cost per student is in inverse proportion to the height of the building. Also in lower buildings roofs have greater architectural significance. Representative costs of roofs is from \$200 to \$235 per student resident.

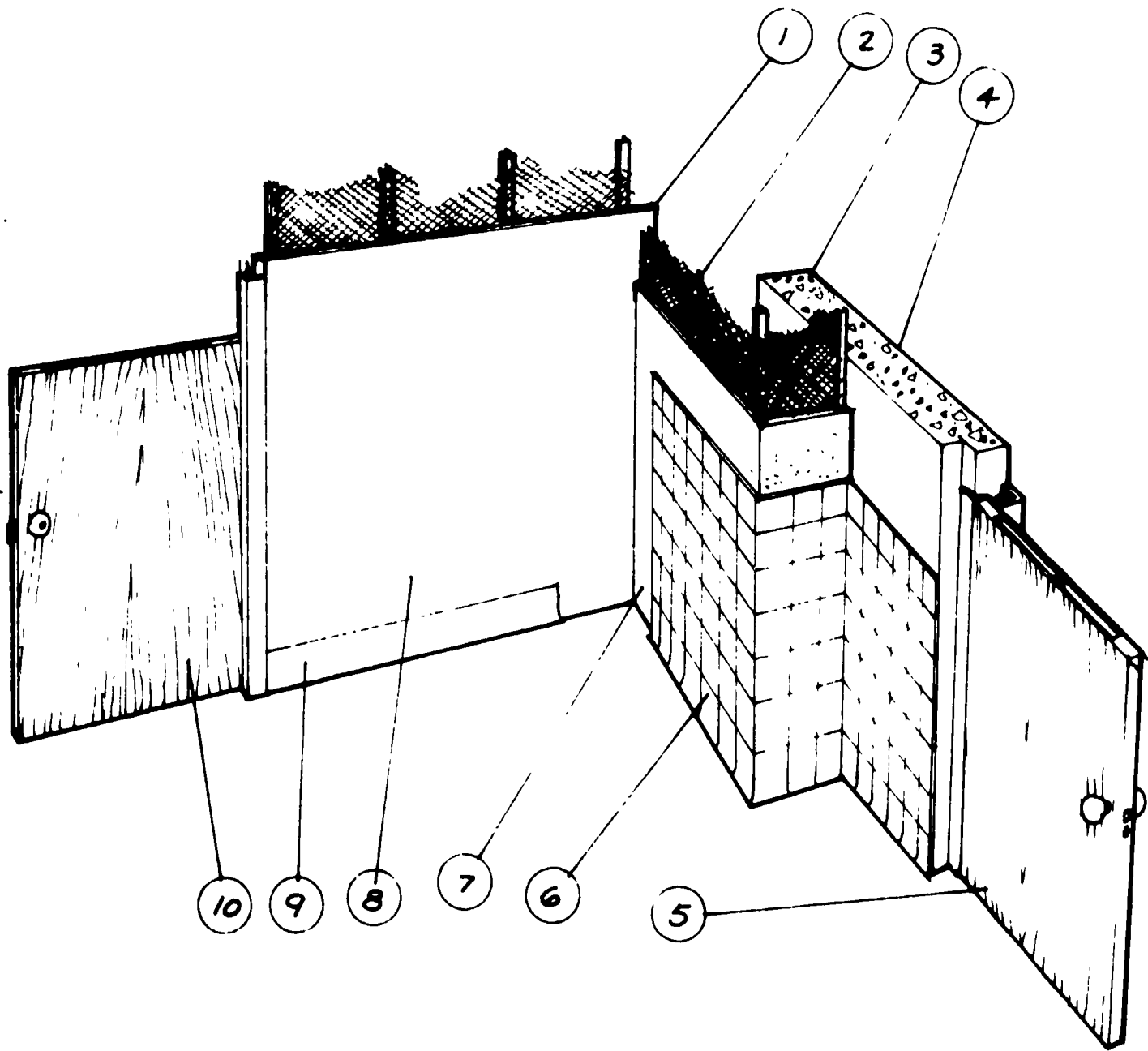

INTERIOR PARTITIONS - 2nd, 3rd, 4th & 5th

1. 2" SOLID PLASTER WALL ..	0.61
2. FURRED PLASTER ..	0.16
3. CONCRETE WALL ..	0.99
4. STIPPLE PAINT ON CONCRETE ..	0.14
5. HOLLOW METAL DOORS ..	0.31
6. CERAMIC WALL TILE ..	0.39
7. STIPPLE PAINT ON GYPSUM PLASTER ..	0.05
8. WASHABLE PAINT ON GYPSUM PLASTER ..	0.21
9. RUBBER BASE ..	0.10
10. WOOD DOORS w/ METAL FRAMES ..	0.36
	<hr/>
	3.32

9800 sq. ft. = \$ 32,510.

\$955 per student resident

HIGH COST - ELEMENT No. 4, RESIDENCE HALL C

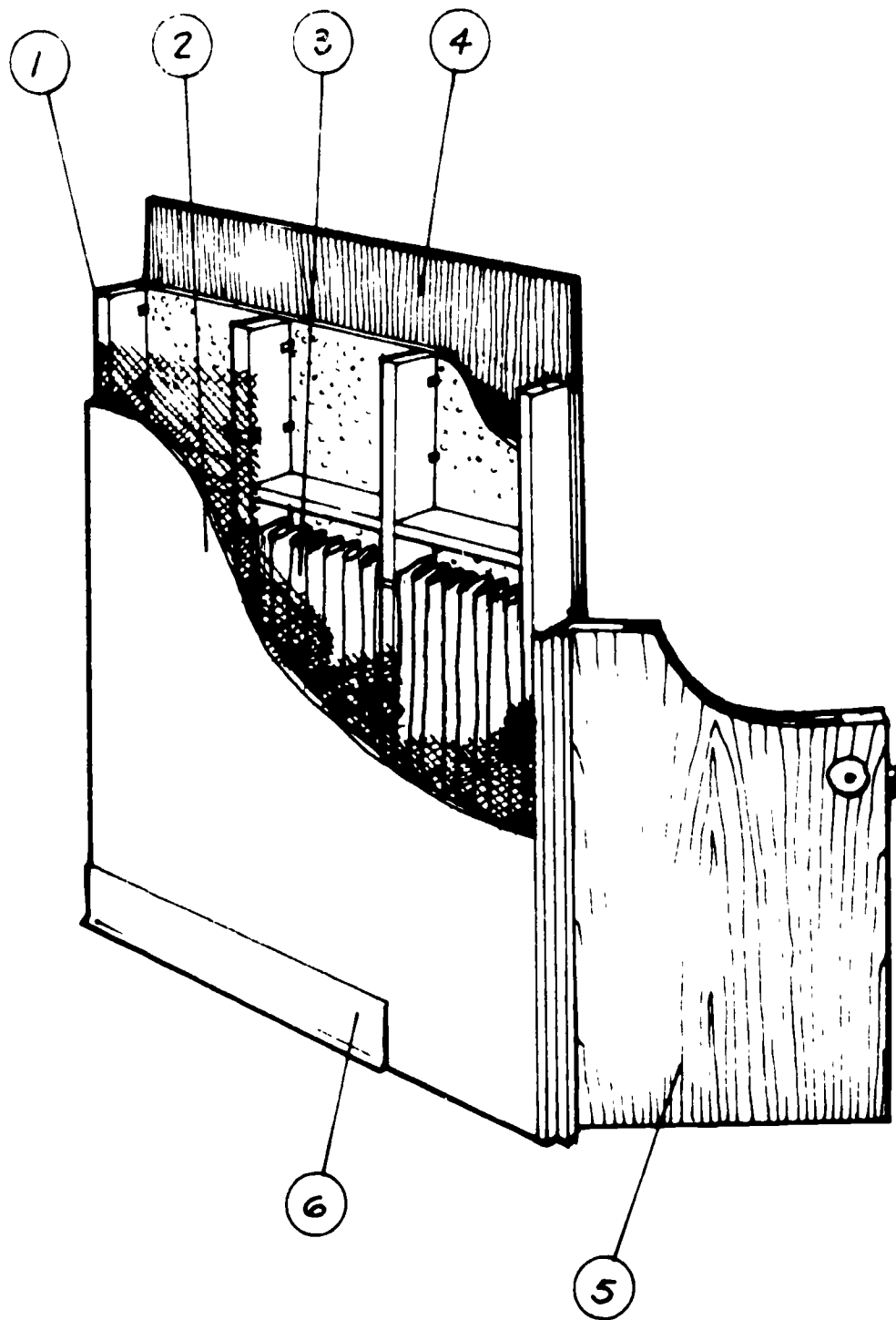

INTERIOR PARTITIONS:

1. WOOD FRAMING	0.27
2. LATH & PLASTER ON RESILIENT CLIPS	0.65
3. SOUND INSULATION	0.11
4. HARDBOARD FACING	0.09
5. WOOD DOORS - METAL FRAMES	0.82
6. VINYL BASE	0.09
	2.03

70,400 sq. ft. = \$ 143,400.
 \$422 per student resident

LOW COST - ELEMENT No. 4, RESIDENCE HALL D

COMPARISON OF HIGH AND LOW COST BUILDING ELEMENT NO. 4

4. Interior Partition System

Building C is high in cost because the interior toilet core of this multi-story building and its vertical circulation areas are enclosed by concrete bearing walls which serve as interior partitions in addition to the bedroom-enclosing plaster partitions.

Building D is low with wood stud partitions, bat sound insulation and interior stucco surfaces mounted on resilient clips.

General: A factor which is not too apparent in the buildings under consideration is the extent of interior partitioning required for single-room as against double-room distribution. In the buildings studied the coincidence occurred that the plans with single rooms and suites also had irregular exterior conformations which reduced the ratio of interior-to- exterior wall. Obviously single rooms require more doors and other expensive partition details. Therefore this analysis deals with the representative costs of interior partitions in two ways.

1. If preponderantly double rooms the representative cost of interior partitions is \$540 to \$660 per student.

2. If preponderantly single rooms the representative cost will be above the mean, from \$660 to \$880 per student.

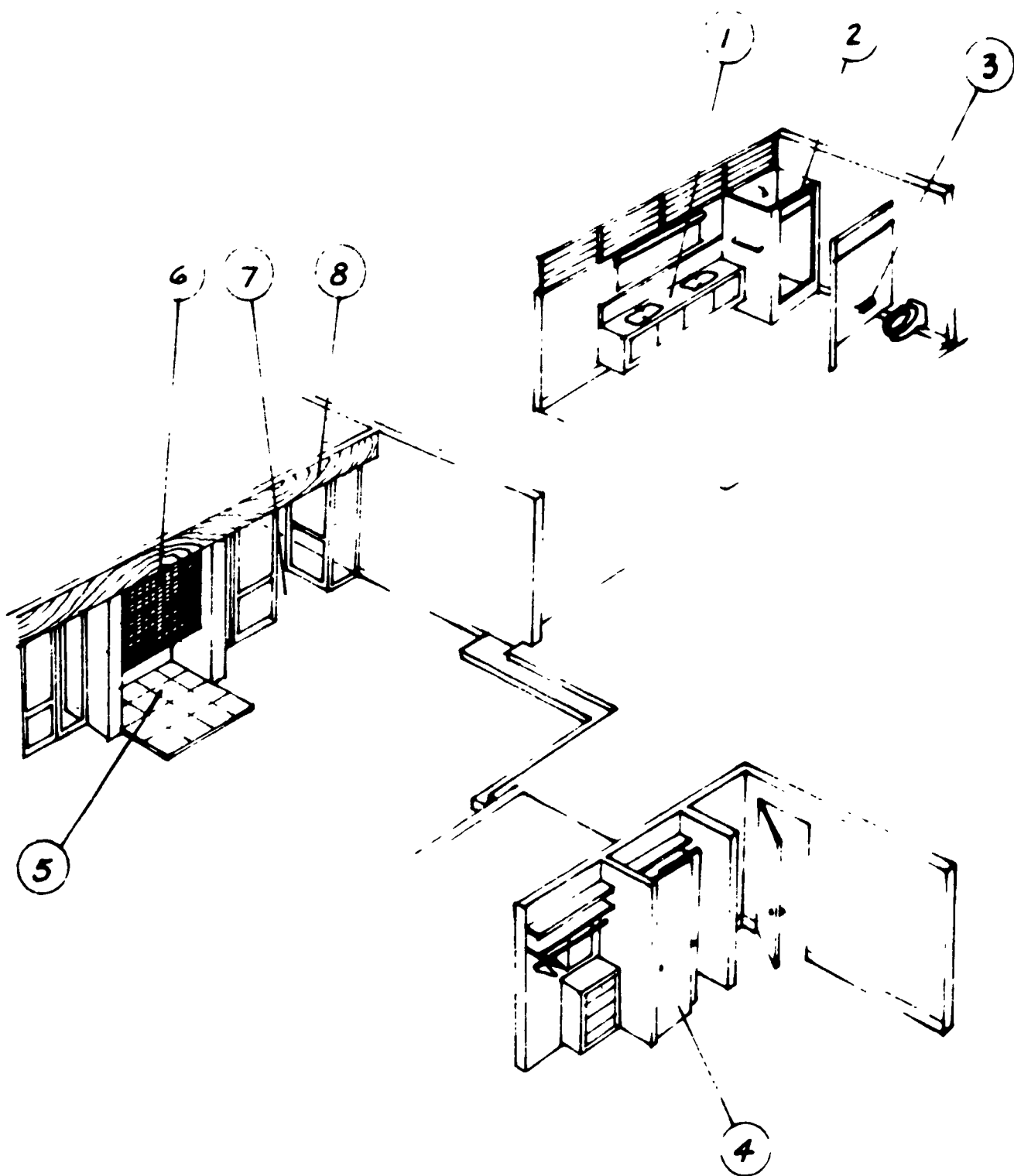

INTERIOR GENERAL :

1. CABINETS, MIRRORS	_ 0.08
2. SHOWER & TOILET STALLS	_ 0.21
3. TOILET ACCESSORIES	_ 0.03
4. WARDROBES	_ 0.57
5. FIREPLACES	_ 0.13
6. GLASS WALL TILE	_ 0.02
7. NEOPRENE DECK	_ 0.04
8. FINISH CARPENTRY & PAINT	_ 0.22
	<hr/>
40,000 sq ft @ 1.30 = \$117,300	1.30

\$352 per student resident

HIGH COST - ELEMENT No. 5, RESIDENCE HALL D

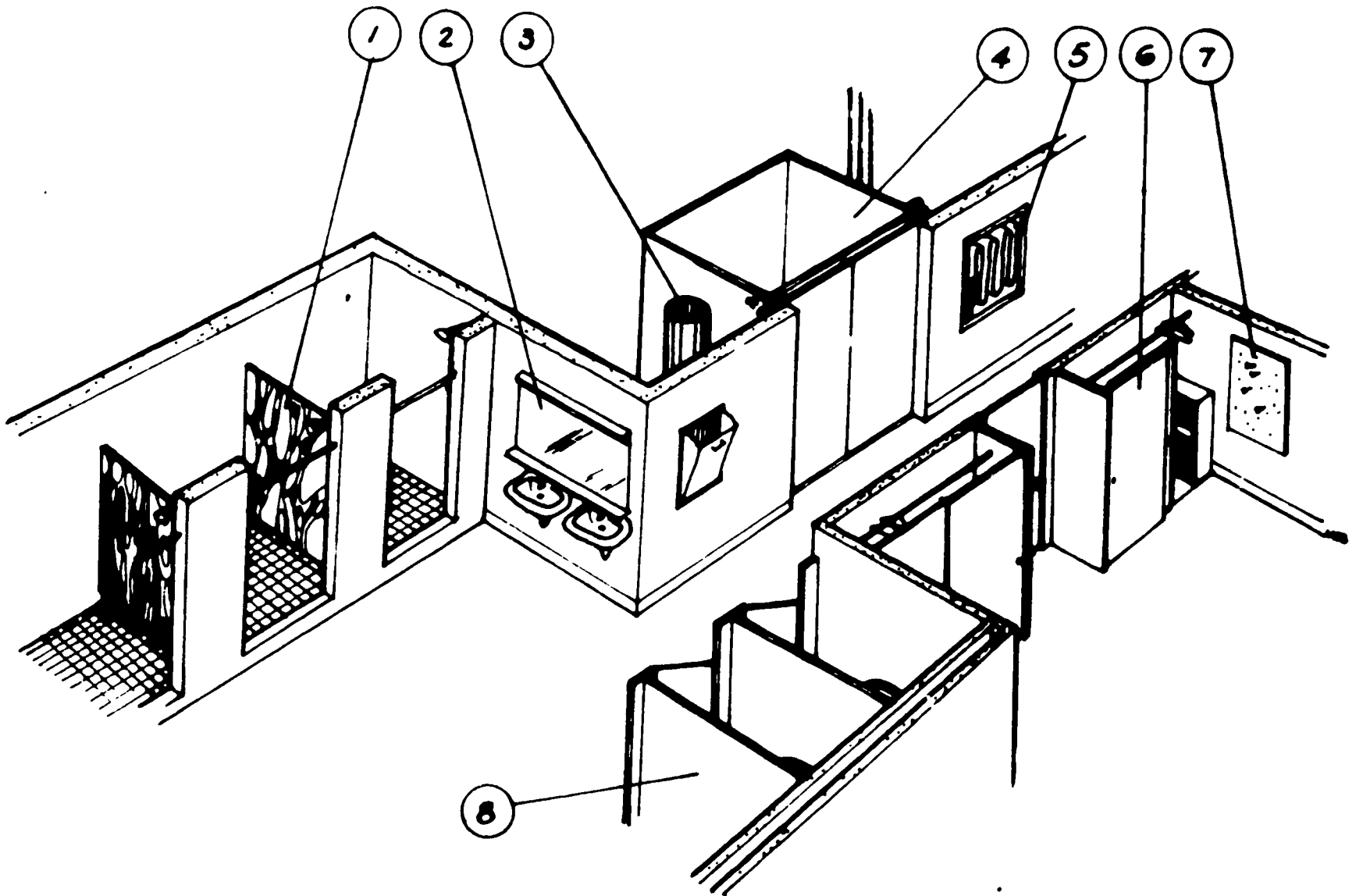

INTERIOR - GENERAL:

1. MARBLE SHOWER PARTITIONS	0.01
2. MIRRORS	0.02
3. TRASH CHUTES	0.01
4. ELEVATORS	0.57
5. FIRE HOSE CABINETS	0.01
6. WARDROBE CABINETS	0.09
7. TACKBOARDS, ETC.	0.02
8. TOILET STALLS	0.03
	<hr/>
	0.76

69,600 sq. ft. = \$52,700.
 \$142 per student resident

LOW COST - ELEMENT No. 5, RESIDENCE HALL B

COMPARISON OF HIGH AND LOW COST BUILDING ELEMENT NO. 5

5. General Interior

Building D is high providing extensive cabinetwork and mirrors in suite bathrooms in addition to built-in wardrobe chests.

Building B is low with minimum provision for tackboards, mirrors, etc.

General: In the current residence halls studied the average functional fittings of this type under the construction cost \$240 per student.

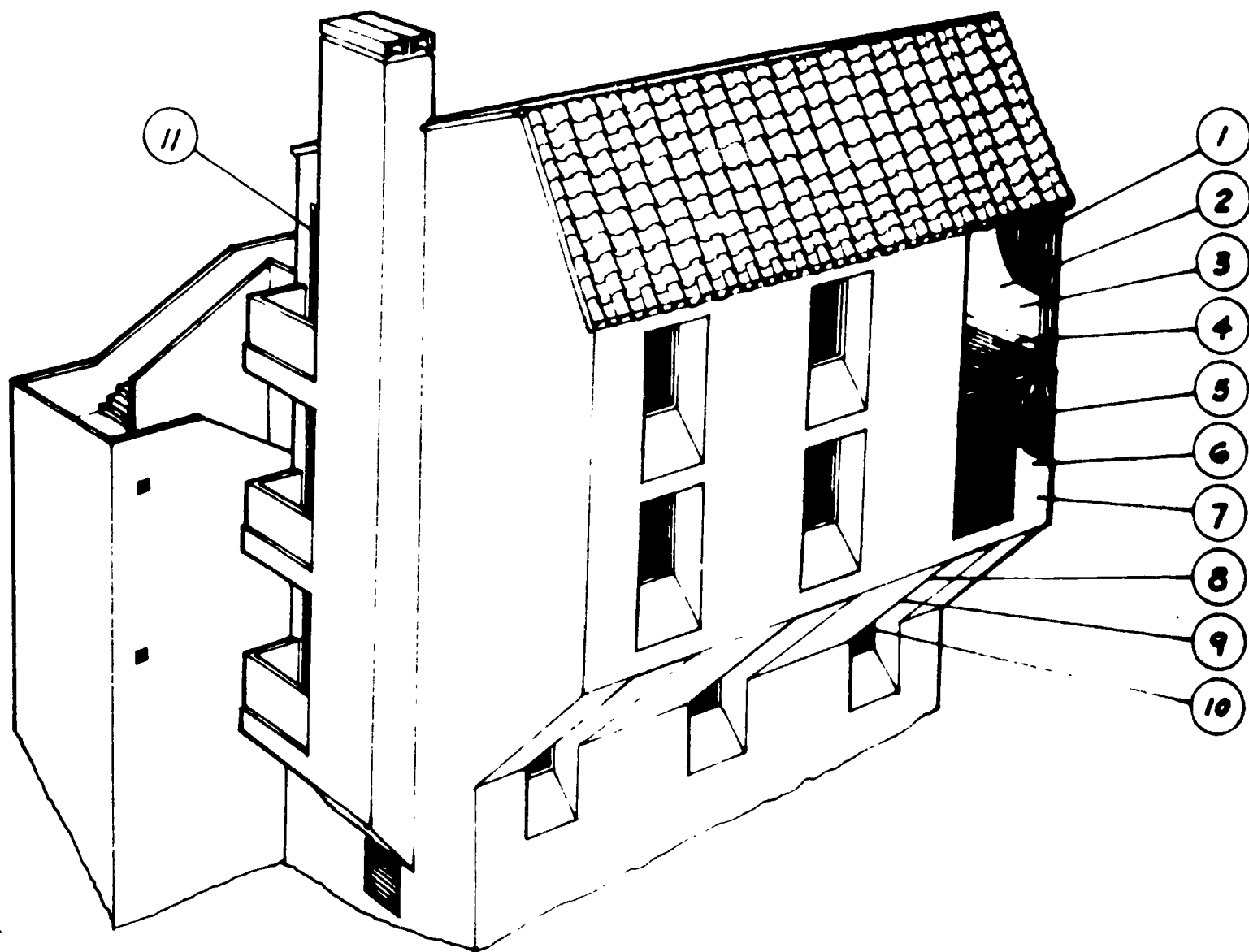

EXTERIOR SKIN:

1. WOOD FRAMING	0.40
2. INTERIOR GYPSUM BOARD	0.18
3. INTERIOR PAINT ON GYPSUM	0.12
4. INTERIOR TRIM, BASE, ETC.	0.04
5. 3/8" PLYWOOD STRUCTURAL SHEATHING ..	0.40
6. EXTERIOR STUCCO	0.45
7. EXTERIOR PAINT	0.20
8. INTERIOR METAL LATH & PLASTER ..	0.10
9. INTERIOR PAINT ON PLASTER	0.04
10. WOOD WINDOWS & GLAZING	0.30
11. EXTERIOR DOORS	0.06
	<hr/>
140,000 sq.ft. @ 2.37 = \$331,370.	2.37
\$959. per student resident	

HIGH COST - ELEMENT No. 6, RESIDENCE HALL E

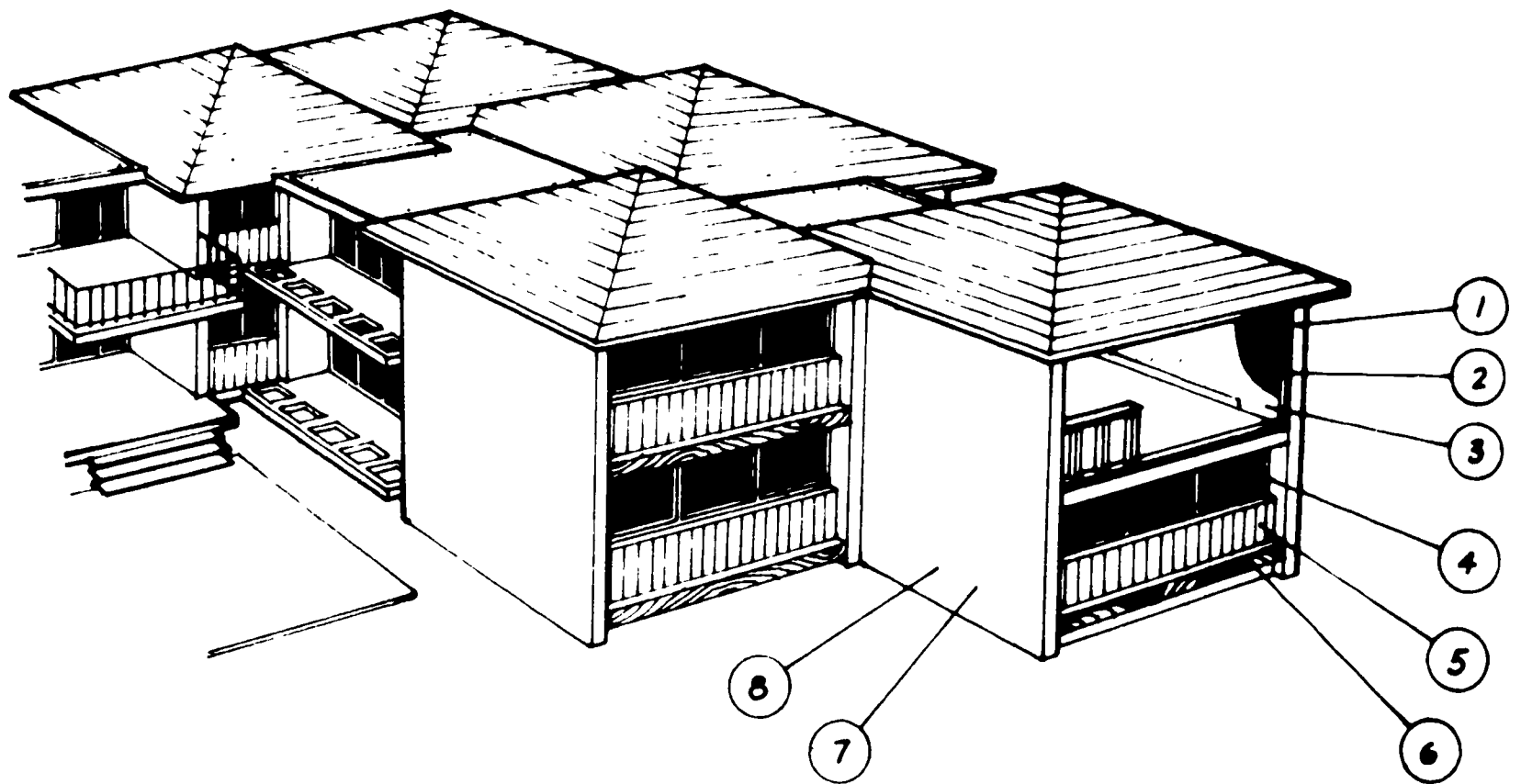

EXTERIOR SKIN:

1. EXTERIOR WALL FRAME	0.20
2. THERMAL INSULATION	0.09
3. INTERIOR GYPSUM LATH & PLASTER	0.19
4. ALUMINUM WINDOWS & GLAZING	1.07
5. EXTERIOR WOOD SIDING	0.08
6. EXTERIOR WOOD TRIM	0.20
7. EXTERIOR STUCCO	0.22
8. EXTERIOR PAINT	0.05
	<hr/>
80,000 sq. ft. @ \$2.10 =	\$168,250.
	<hr/>
\$459 per student resident	

LOW COST - ELEMENT No. 6, RESIDENCE HALL D

COMPARISON OF HIGH AND LOW COST BUILDING ELEMENT NO. 6

6. Exterior Skin

Building E is high. Although it is wood frame and plaster in construction, it is unusually extensive because of many offsets, both vertically and horizontally.

Building D is low because of its relatively simple and conventional frame and stucco construction.

General: Largest factors involved in exterior skin cost appear to be the architectural elaborateness and the ratio of periphery to floor area. Representative cost is \$720 per student.

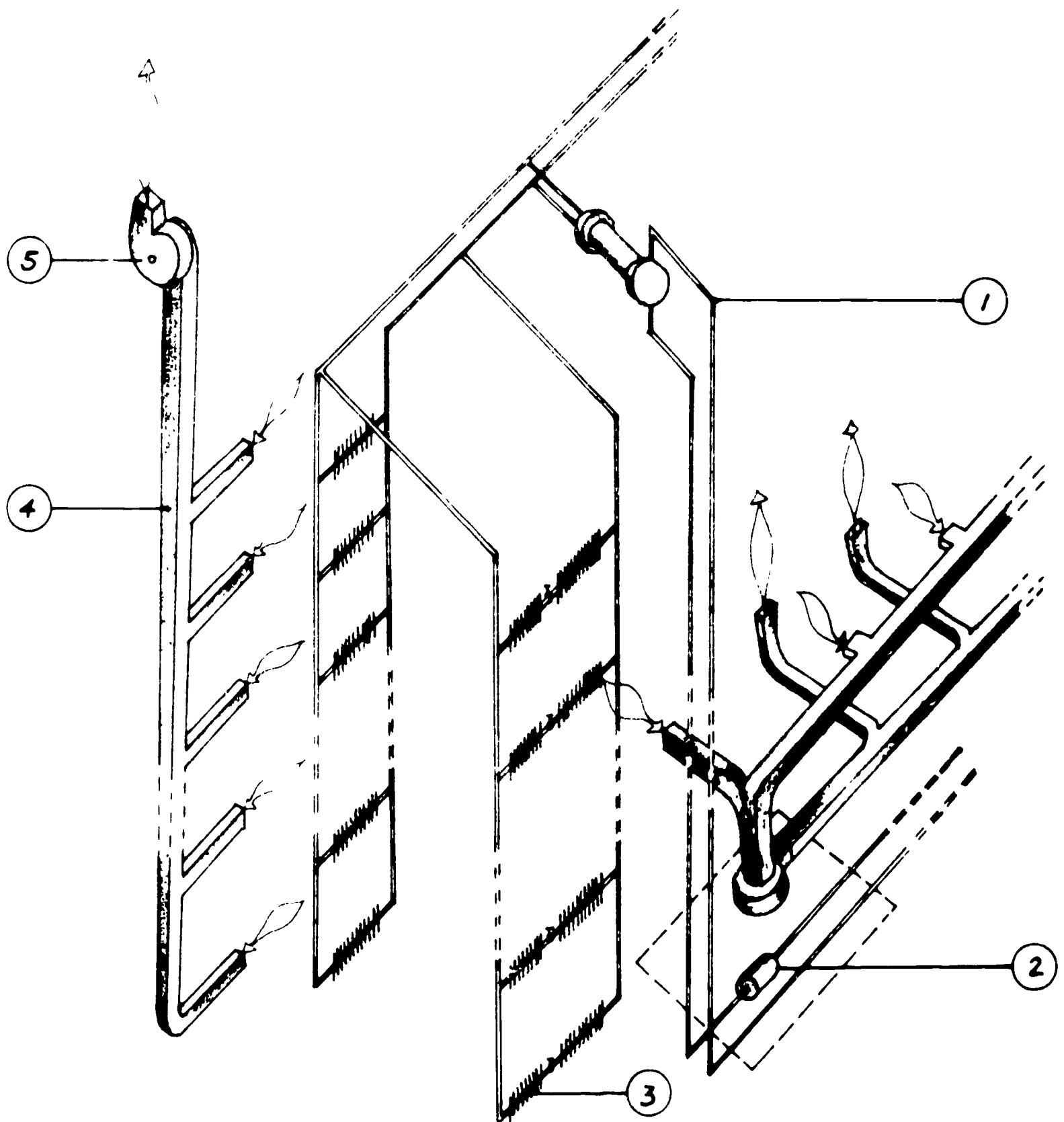

HEATING & VENTILATING:

1. HOT WATER & STEAM PIPING	0.16
2. MECHANICAL ROOM EQUIPMENT	0.31
3. BASEBOARD CONVECTORS	0.37
4. DUCTWORK - BATHROOMS	0.42
5. ROOF EXHAUST FANS	0.02
	1.28

40,000 sq. ft. = \$51,255.
 \$276 per student resident

LOW COST - ELEMENT No. 8, RESIDENCE HALL A

(Note: Elements 7, 9, and 10 are not included in this analysis.)

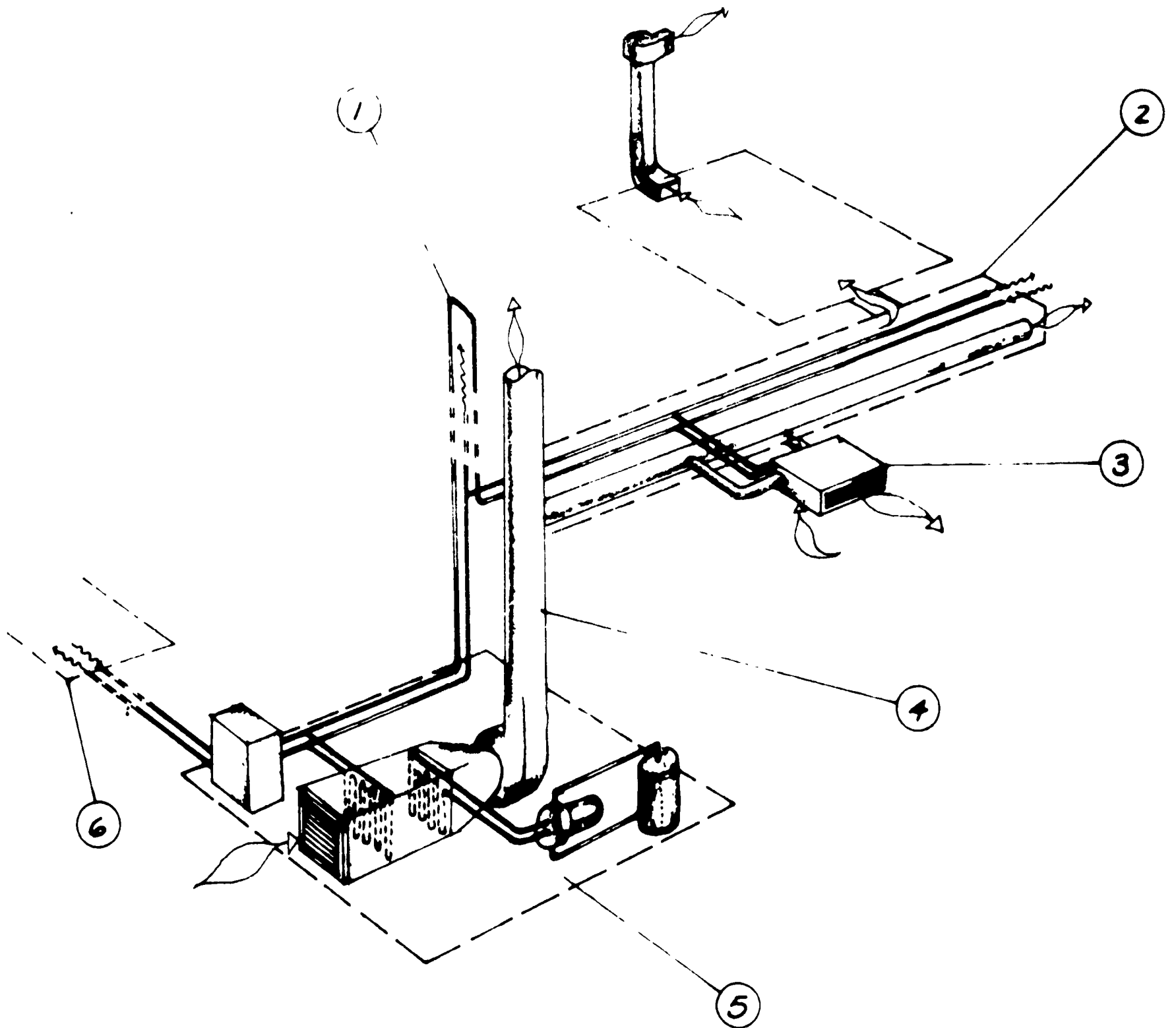

HEATING, VENTILATING & AIR CONDITIONING :

1. CHILLED WATER & HOT WATER	1.12
2. TOILET & CORRIDOR DUCTWORK	0.38
3. ROOM INDUCTION UNITS	0.75
4. DUCTWORK TO ROOMS	0.45
5. MECHANICAL ROOM EQUIPMENT	0.21
6. COOLING TOWER, ETC.	0.90
	<hr/>
69,600 sq. ft. = \$265,495.	3.81
\$839 per student resident	

HIGH COST - ELEMENT No. 8, RESIDENCE HALL B

(Note: Elements 7, 9, and 10 are not included in this analysis.)

COMPARISON OF HIGH AND LOW COST BUILDING ELEMENT NOS. 7, 8, 9, and 10

7. Plumbing Systems (No illustrative example)

Building D is high as a result of two-story isolated buildings and suite arrangements with 8 or 9 students per bathroom.

Building A is low in a rather tightly grouped series of gang bath plans.

General: Plumbing for suites appears to cost about \$100 more per student than in gang toilets. However, this is sometimes offset by lower space requirements of baths for smaller groups and a reduced use of ceramic wall and floor surfacing. As a part of a current URBS study it may be demonstrated that there is appreciably less operational and maintenance cost for smaller bath units since students do most of the cleanup involved. A figure of \$340 per student may be assumed for plumbing for traditional gang toilets. However, \$435, as in Building D, may be considered applicable for plumbing costs in suite plans.

8. Heating, Ventilating and Air Conditioning

Building B is high because it is the only fully air conditioned building in the group.

Building A is low. It is heated by hot water base-board convectors, manually controlled, with exhaust through toilet rooms.

General: The systems illustrated by the five buildings represent extremes in the quality of comfort control that might be produced. A non-air conditioned system, without positive mechanical room ventilation, can be expected to provide adequate comfort in a mild climate for \$325 per student.

9. Electric Systems (No illustrative example)

There is no significant difference in the unit cost of electrical installation. (The one electric heating system, in Building D, is considered under Heating, Ventilating and Air Conditioning.) The average electric system is \$230 per student.

10. Elevators (No illustrative example)

Elevator costs are arbitrary, heavily dependent upon the number of people per floor served by each elevator.

PART VI. GENERAL INFORMATION

There has been a surprising enthusiasm among the manufacturers for the URBS approach to system components.

Prior to submitting the initial proposal to the Regents and EFL in 1965, selected manufacturers of various building components were contacted to see what interest there might be in such a project as URBS. Without exception, there was support for the idea.

Subsequent to the approval and public announcement of the project, inquiries and responses from industry were immediate and enthusiastic--even more than had been expected. Many of the manufacturers have been helpful in suggestions as to what some of the potentials might be, given adequate assurance of sufficient volume to undertake needed research in some of the areas. There is every reason to believe that there will be keen competition among the country's better manufacturers on all the proposed components. Following are various manufacturers who have indicated more than a passing interest in this system.

A. LIST OF MANUFACTURERS WHO HAVE INDICATED INTEREST IN URBS

STRUCTURE - CEILING

H. H. Robertson Co. San Francisco, California	Compatible Design Systems Co. Santa Clara, California
Engineer's Collaborative Chicago, Illinois	Western Concrete Structures San Jose, California
American Cement Co. Riverside, California	Republic Steel Corporation San Francisco, California
General Dynamics Chicago, Illinois	National Steel Corporation Detroit, Michigan
United States Steel Corporation Pittsburgh, Pennsylvania	U. S. Gypsum Company Des Plaines, Illinois
T. Y. Lin Associates San Francisco, California	U. S. Gypsum Company Chicago, Illinois
Airfloor Company of California Santa Fe Springs, California	Bethlehem Steel San Francisco, California
Scherrer and Bauman Santa Ana, California	U. S. Steel San Francisco, California
Morton Structural Systems, Inc. Burlingame, California	Ben C. Gerwick, Inc. San Francisco, California
Inland Steel Products Company Milwaukee, Wisconsin	Northwest LCFI Scab Company Portland, Oregon

(Structure-Ceiling Manufacturers continued)

The R. C. Mahon Company
Detroit, Michigan

Atlas Prestressing Corporation
San Francisco, California

Pittsburgh-Des Moines Steel Co.
Santa Clara, California

Ceco Steel Products Corporation
San Francisco, California

Rockwin Prestressed Concrete Corp.
Santa Fe Springs, California

Basalt Rock Company, Inc.
San Francisco, California

Kaiser Steel
Oakland, California

Portland Cement Association
Los Angeles, California

HEATING, VENTILATING AND COOLING CATEGORY

Carrier Air Conditioning Company
Syracuse, New York

The Trane Company
La Crosse, Wisconsin

American Air Filter Company, Inc.
Louisville, Kentucky

General Electric Company
Louisville, Kentucky

American Air Filter Company, Inc.
Walnut Creek, California

ITT Nesbitt
Philadelphia, Pennsylvania

York Division of Borg Warner
York, Pennsylvania

Lennox Industries, Inc.
Marshalltown, Iowa

Lennox Industries, Inc.
Palo Alto, California

Westinghouse Electric Corporation
San Francisco, California

BATHROOM UNIT CATEGORY

Crane Supply Company
Oakland, California

W. L. Hickey Sons, Inc.
Sunnyvale, California

Owen-Corning Fiberglas
Santa Clara, California

National Fiberglas Corporation
Gilroy, California

Universal-Runkle Corporation
San Francisco, California

W. E. Joost Company
San Rafael, California

Redwood Plumbing and Heating Co.
Redwood City, California

Associated Design Group
Salt Lake City, Utah

McClenahan Company
San Mateo, California

American-Standard Corporation
New York, New York

FURNITURE

Simmons Company
Chicago, Illinois

Troy Sunshade Co., Hobard Mfg. Co.
Troy, Ohio

(Furniture Manufacturers continued)

Brunswick Corporation
Kalamazoo, Michigan

Knoll Associates
San Francisco, California

General Fireproofing Company
San Francisco, California

Dickson-Smith
El Cajon, California

Royal Metal Corporation
New York, New York

Herman Miller
Ann Arbor, Michigan

Educators
Tacoma, Washington

Thonet Industries, Inc.
New York, New York

PARTITIONS

Hough Manufacturing
Janesville, Wisconsin

Partition Specialties, Inc. (Mills)
Redwood City, California

Fiberboard Paper Corporation (Pabco)
San Francisco, California

Brookman Company (Vaughan Wall,
Donn Products)
San Francisco, California

Weber Showcase & Fixture Company
Los Angeles, California

E. F. Hauserman Company
Cleveland, Ohio

Westinghouse Architectural Systems, Inc.
Pittsburgh, Pennsylvania

Brunswick Corporation
Kalamazoo, Michigan

In addition, many basic materials manufacturers such as Johns-Manville, U. S. Gypsum, U. S. Plywood Minnesota Mining and Manufacturing Co., etc., have expressed interest in the project.

B. ORGANIZATION CHART

for

UNIVERSITY RESIDENTIAL BUILDING SYSTEMS PROJECT

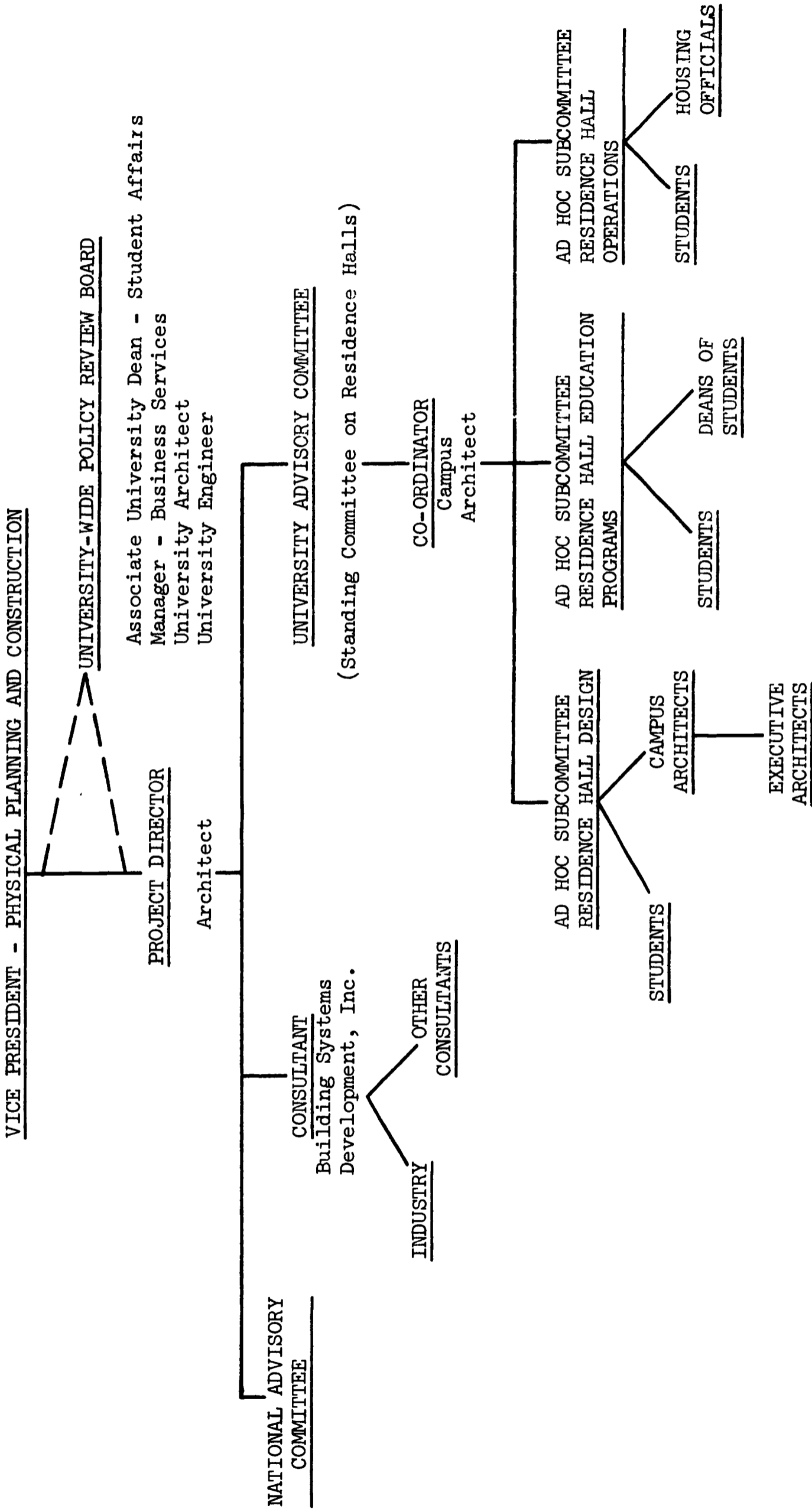

C. NATIONAL ADVISORY COMMITTEE

- Elmo R. Morgan: Vice President - Physical Planning and Construction, University of California; chairman of the committee.
- Louis T. Benezet: President, Claremont Graduate School and University Center.
- Frank Burrows: Part-owner in firm of Williams and Burrows, Inc., General Contractors; has wide interest in full range of activities in construction industry.
- Jay duVon: Director, Division of College Facilities, U.S. Office of Education.
- Paul Emmert: Executive Secretary for Program Policy Review Board, Community Facilities Administration, Dept. of Housing & Urban Development; formerly head of San Francisco office of Housing and Home Finance Agency.
- Robert L. Geddes: Dean, School of Architecture, Princeton University; principal in firm of Geddes, Brecher, Qualis and Cunningham of Philadelphia.
- Cornelius J. Haggerty: President, Building and Construction Trades Department, AFL-CIO; Regent of the University of California.
- William LeMessurier: Owner of LeMessurier and Associates, structural engineers; was Professor of Structural Engineering at Massachusetts Institute of Technology.
- Donald E. Neptune: AIA. Has served as executive architect for several University of California projects; also past President of California Chapter of American Institute of Architects.
- Walter Andrew Netsch: General partner in Skidmore, Owings and Merrill; was member of Advisory Committee for Stanford's School Construction Systems Development project.
- Theodore Newcomb: Professor of Psychology in Department of Sociology, University of Michigan; also co-chairman of planning committee for experimental student house at University of Michigan; has great interest in student housing.
- Fred A. Schwendiman: Director, Auxiliary Services, Brigham Young University; also past President of Association of College and University Housing Officers.
- Robert Shaffer: Dean of Students, University of Indiana; and regional President of National Association of Student Personnel Administrators.
- Jonathan King: Secretary-Treasurer, Educational Facilities Laboratories, Inc.; ex officio member of the committee.