

DOCUMENT RESUME

ED 031 555

VT 007 853

Woodworking Technology.

San Diego State Coll., Calif. Dept. of Industrial Arts.

Spons Agency-Office of Education (DHEW), Washington, D.C.

Pub Date Aug 68

Note-252p.; Materials developed at NDEA Inst. for Advanced Study in Industrial Arts (San Diego, June 24-August 2, 1968).

EDRS Price MF-\$1.00 HC-\$13.20

Descriptors-Curriculum Development, \*Industrial Arts, Instructional Materials, Learning Activities, Lesson Plans, Lumber Industry, Resource Materials, \*Resource Units, Summer Institutes, Teaching Guides, \*Units of Study (Subject Fields), \*Woodworking

Identifiers-\*National Defense Education Act Title XI Institute, NDEA Title XI Institute, Woodworking Technology

Six teaching units which were developed by the 24 institute participants are given. "Wood Identification and Chemistry" covers the physical properties and structural features of hardwoods and softwoods. "Seasoning" explains air drying, kiln drying, and seven special lumber seasoning processes. "Research on Laminates" describes the bending of solid wood and wood laminates, beam lamination, lamination adhesives, and plastic laminates. "Particleboard: A Teaching Unit" explains particleboard manufacturing and the several classes of particleboard and their uses. "Lumber Merchandising" outlines lumber grades and some wood byproducts. "A Teaching Unit in Physical Testing of Joints, Finishes, Adhesives, and Fasteners" describes tests of four common edge joints, finishes, wood adhesives, and wood screws. Each of these units includes a bibliography, glossary, and student exercises. (EM)

ED031555

110

21

# A DIGEST

*March*

# WOODWORKING TECHNOLOGY INSTITUTE



SAN DIEGO STATE COLLEGE

1897

1968

**NDEA INSTITUTE  
for Advanced Study**

**in**

**INDUSTRIAL ARTS**

**June 24 to August 2**

VT007853

THIS DOCUMENT HAS BEEN REPRODUCED EXACTLY AS RECEIVED FROM THE  
PERSON OR ORGANIZATION ORIGINATING IT. POINTS OF VIEW OR OPINIONS  
STATED DO NOT NECESSARILY REPRESENT OFFICIAL OFFICE OF EDUCATION  
POSITION OR POLICY.

**1968**

**NDEA INSTITUTE**  
**for Advanced Study**  
**in**  
**INDUSTRIAL ARTS**

**WOODWORKING**  
**TECHNOLOGY**

**Six Week Session**  
**June 24 to August 2**



**in cooperation with**  
**U. S. Office of Education**  
**as authorized under**  
**Title XI**  
**of the**  
**NDEA**  
**(as amended)**

**INDUSTRIAL ARTS DEPARTMENT**  
**SAN DIEGO STATE COLLEGE**  
**San Diego, California**

FACULTY

Dr. Gerald K. Hammer, Director

Harold L. Marsters, Assistant Director

Frank E. Evans, Coordinator

STAFF

Gudrun Fairchild, Secretary

Luther E. Daugherty, Lab Assistant

David E. Graham, Lab Assistant

Harley J. Gasman, Student Assistant

Robert G. Hanlon, Student Assistant

Charles J. Printz, Student Assistant

David W. Sykes, Student Assistant

PARTICIPANTS

NDEA INSTITUTE IN WOODWORKING TECHNOLOGY

ACKER, Robert A.  
Oreland, Pennsylvania

AIMONE, Eugene D.  
Wheaton, Illinois

BIRZER, Ervin G.  
Santa Barbara, California

BONAN, Al L.  
Montrose, Colorado

DAVIS, Ray M.  
Tucson, Arizona

DIENER, Robert F.  
Kansas City, Missouri

FOLTZ, William W.  
Northridge, California

FREEMAN, Donald B.  
Cheyenne, Wyoming

GADWAH, Neal D.  
Hampton, New Hampshire

HARLOW, James Frank  
Abilene, Texas

JOHNSON, Stanley J.  
Crane, Oregon

JONES, Benjamin H.  
Carlsbad, New Mexico

LONG, William A.  
Blanchard, Pennsylvania

MOORE, Robert J.  
Fargo, North Dakota

MURDOCK, Percy  
Picayune, Mississippi

READING, Norman E.  
Columbus, Ohio

RICHARDSON, Theral B.  
Salt Lake City, Utah

ROSSI, James M.  
California

SALA, Howard  
Denver, Colorado

SEIFERT, Harry C.  
San Diego, California

SMITH, Richard M.  
Burlington, Iowa

THORSEN, Michael O.  
Edmonds, Washington

WALKER, Belton L.  
Winter Park, Florida

WILLIAMS, A. D.  
Haynesville, Louisiana

TABLE OF CONTENTS

**INSTITUTE DATA** . . . . . **i**

**STAFF** . . . . . **ii**

**PICTURE OF PARTICIPANTS AND STAFF** . . . . . **iii**

**LISTING OF INSTITUTE PARTICIPANTS** . . . . . **iv**

**SECTION I - WOOD IDENTIFICATION AND CHEMISTRY**

**SECTION II - SEASONING**

**SECTION III - RESEARCH ON LAMINATES**

**SECTION IV - PARTICLEBOARD: A Teaching Unit**

**SECTION V - LUMBER MERCHANDISING**

**SECTION VI - A TEACHING UNIT IN PHYSICAL TESTING**



WOOD IDENTIFICATION AND CHEMISTRY

---

Presented to

Dr. G. K. Hammer

Mr. H. Marsters

Mr. F. Evans

San Diego State College

---

In Partial Fulfillment

of the Requirements for the Course 298

Wood Technology Institute

---

by

Robert Acker

Robert Diener

Percy Murdock

Richard Smith

Summer 1968

## TABLE OF CONTENTS

PREFACE	Page 1
PHYSICAL PROPERTIES OF WOOD	Page 2
STRUCTURAL FEATURES OF WOOD	Page 6
SOFTWOODS	Page 12
HARDWOODS	Page 21
THE CHEMISTRY OF WOOD	Page 31
WOOD PRESERVATIVES	Page 34
BIBLIOGRAPHY	Page 38
GLOSSARY (see Teaching Aids)	Page 40
TEACHING AIDS	Page 40
STUDENT LAB EXPERIENCES	Page 48
HANDOUT SHEETS	Page 51



## PREFACE

Wood identification, as mentioned in this paper, should give the reader a better understanding of the identification of many species. In this paper we believe that it is necessary for students to have a better understanding of how to identify different species, which will lead to better selection of woods for jobs in everyday life.

Identification of wood is comparatively more difficult than identification of the tree that produced it. There are two main procedures for wood identification--by keys and by cards.

The most pronounced the reliable specific difference in the appearances of woods are found in their cellular structure.

Color, odor, weight and hardness help in identifying woods, but as a rule such qualities are too variable to be used singly in distinguishing a large number of woods.

Hardwood of ring-porous and diffused-porous will be defined with information about general characteristics, such as growth rings, rays, vessels, sapwood, and heartwood.

Softwoods can be divided into two groups; the resinous, those species having resin ducts and the nonresinous, those without resin ducts. There are no perfect tools for wood identification. While we have attempted to give an approach to this problem that seems to be good; we feel there is still room for research and study.

## COLOR A KEY TO WOOD IDENTIFICATION

Wood comes in a variety of natural colors which may range from almost white, as in the sapwood of many species, to the jet black of the heartwood of black ebony. Color differences may exist, however, in a single sample of wood; as between sapwood and heartwood, earlywood and latewood, or between ray tissue and the surrounding wood. Heartwood present a wide variation of colors, predominantly browns of various shades. Sapwood is always lighter.

Color characterizes various species, but is a feature difficult to describe with words. Also, it may vary within a species and is subject to change due to exposure or treatment. Usually, color is estimated visually, but it may also be measured by technical means. The color of wood exposed to the atmosphere frequently darkens; sapwood usually darkens more than heartwood. Such changes are generally chemical in nature; they result from oxidation of organic compounds contained in wood. Change of color may take place soon after felling trees in the forest, or after sawing green logs to lumber. The wood of alder quickly changes from whitish or reddish, then fades to a pale brown. The heartwood of black locust turns from light green to dark brown. Douglas-fir becomes reddish. Long exposure of light-colored woods to the sun, especially in high elevations, changes their color to brown, while long exposure to rain or high humidity changes them to dark gray.

Dark natural color usually indicates high durability. In general, color is imparted to wood by extraneous materials deposited mainly in the heartwood. Many of these materials, known also as extractives, are toxic to wood decaying fungi. Their presence is the cause of high durability of woods like redwood, cypress, cedar, oak, black locust, and osage-orange. For the same reason, heartwood of these and other species is more durable than sapwood, and woods like basswood, willow, and poplar possess low durability. Light color, however, does not always denote lack of durability. Bald cypress, certain cedars and sassafras are examples.

Color-imparting materials may be so abundant in some woods that they can be utilized as dyes. Before the development of synthetic coloring materials. Some dyes were obtained from woods. It is also noteworthy that some woods, such as black locust, honey locust, and a number of tropical species are fluorescent.

Natural coloration in many woods is very attractive and may be preserved with transparent finishes, or it may be artificially changed by dyeing or bleaching. Color changes may also

be produced by action of water or steam. Oak becomes almost black after prolonged storage under water. European beech is often steamed to darken its color and make it more desirable for the furniture market. Walnut and sweetgum are also treated with steam to darken their sapwood so that it is better matched with heartwood. (1: 525-527) In inexpensive furniture the nature color of various woods is often imitated by drying less expensive species.

Irregular deposition of coloring materials may cause local variation in color, color changes may also result from fungal and bacterial attack, or other reasons.

#### Luster, A Characteristic of Wood

Some woods possess a natural luster, which may be distinguished from artificial luster in that the former has depth while the latter is superficial. As a rule, woods exhibit more luster on radial surfaces, due to exposure of rays. Luster is also affected by the angle of light reflection.

Among lustrous woods are spruce, ash, sycamore, basswood, and poplar. On the contrary, the surface of other woods feels greasy, as for example bald cypress, olive, teak and *lignum vitae*.

#### Odor, A Factor in Wood Identification

Odor in wood is due to volatile extraneous materials. Such materials, when present, are mostly deposited in heartwood, where odor is therefore more pronounced. Due to the volatility of these materials, odor gradually fades upon exposure. For this reason it is more prevalent in freshly exposed surfaces.

Like color, odor is not an easy feature to describe. Cedars and cypress possess an aromatic odor, and the odor of pine is resinous. Among other species characteristics is the odor of sassafras, bald cypress has sometimes an unpleasant odor, and catalpa heartwood is to suggest kerosene. (15) Maple when hot and wet, has been described to smell like strawberry jam, teak like burnt leather, and the tropical coachwood like new-mown hay (11) or caramel (13). Other species possess various odors; some have been given suggestive names.

Odor may be an advantageous characteristic, as in the case of Spanish cedar which is used for cigar boxes, or some cedars

and cypress which is preferred for clothes chests. On the other hand, odor is undesirable in wood used for basket, boxes or crates for packing food. Aside from occurring normally, odors may be produced during the decomposition of wood by micro-organisms.

### Taste

Taste is due to volatile deposits. Thus, it is more distinctive in heartwood than in sapwood. Woods like oak and chestnut which contain appreciable amounts of tannin, possess a bitter taste. Taste is not a very important diagnostic feature but it may help in some cases in separating similar woods. For example, the American cedars-incense cedar and western cedar are woods similar in structure and appearance, but the former has a spicy taste whereas the latter is faintly bitter.

### Texture, Grain and Figure

Texture and grain are terms often misused in practice. Expressions such as course, fine, or medium texture are frequently employed as synonymous to analogous qualification of grain. The connotations course, fine, and medium refers to the relative size and proportion of wood elements (cells) as seen by the naked eye or with a hand lens. Large diameter cells produce a course (open) texture or grain, which small diameter cells forms a fine texture or grain. Fast growing trees often produce course wood.

Even or uneven texture, or grains refers to the degree of uniformity of appearances; they indicate differences in structure within a growth ring. Ring-porous woods are generally uneven in comparison to diffuse-porous. Softwoods with abrupt transition from earlywood to latewood have an uneven texture or grain.

The term grain has an additional meaning; it denotes direction of wood elements.

Figure is used to describe the natural design or pattern on wood surfaces.

### Weight and Hardness

Weight, estimated simply by lifting a sample of wood, is an added helpful physical characteristic for purposed of description, identification, and other. However, it should be

remembered that weight is influenced by various factors, such as sapwood and heartwood, proportion of earlywood and latewood, and especially by moisture content. Any comparison, to be valid, should be made under approximately identical conditions. Moisture content is very important, because in light woods the weight of included moisture may exceed many times the weight of the wood substance itself. Moisture is also subject to continuous variation when wood is exposed under varying atmospheric conditions.

Both the lightest and the heaviest commercial woods are tropical. The lightest is balsa, which weighs in dry-air conditions about 5-10 lb/ft<sup>3</sup> (80-160 kg/m<sup>3</sup>), and the heaviest is lignum vitae with about 75-80 lb/ft<sup>3</sup> (1200-1300 kg/m<sup>3</sup>). Common temperate woods weigh in air-dry condition from about 20 to 55 lb/ft<sup>3</sup> (about 300 to 900 kg/m<sup>3</sup>), but there may be a considerable range of variation (up to 10 lb/ft<sup>3</sup> or more) within a species. (24)

Related to weight is the concept of specific gravity. Specific gravity is the ratio of the weight of a sample of material to the weight of a equal volume of water. In the metric system, specific gravity is simply the ratio of weight to volume of wood. The comparative value of specific gravity lies in the fact that it is based on standard hygrometric conditions. Weight is determined after the wood is oven-dried (that is at practically zero moisture content) and volume in either oven-dry or "green" (unseasoned) condition; weight and volume may also be based on any specific moisture content. Because of the way it is determined (weight of material to weight of an equal volume of water), specific gravity has no dimensions. Common temperate woods range in specific gravity (based on oven-dry weight and green volume) from about 0.30 to 0.90. Specific gravities vary mainly because of different amounts of void space in different woods. The specific gravity of wood substance is reported to be approximately 1.5, irrespective of species. (16, 27: 55-61)

Hardness is closely related to weight, heavier woods are harder. However, the effect of moisture is opposite; with increasing moisture content hardness decreases. Hardness is also different on transverse, radial, and tangential surfaces.

## IDENTIFICATION OF WOOD

The properties of wood and its complexities have been recognized for many centuries. Instead of being primarily a solid material like steel or concrete, wood is found to be composed of many tubular fiber units, or cells, cemented together. The largest of these cells are found to be less than one fiftieth of an inch in diameter and a quarter of an inch in length; the only exception being the vessels in which the end walls have been dissolved away to form long, continuous transportation tubes. Those parts which form a basis for wood identification are: tracheids, vessels, wood fibers, medullary rays and resin ducts. That a complete understanding of each term used might be achieved a glossary of terms for "Wood Identification" has been developed.

The study of identifying wood can be divided into two categories; the physical properties--those which have already been touched upon, and the gross structural features. (1:33) These minute features of wood are identified largely upon the kind of cell and their arrangement as seen by the eye. Basically, there are three methods of identification: (1) visual, (2) macroscopic and (3) microscopic. The visual method is by far the simplest and most practical but in many situations low in reliability. In macroscopic identification, a hand lens which enlarges by ten (10X) is used. This method is of higher reliability and is quite practical because expense is small. The method which provides the most in reliability is microscopic, but many times proves to be impractical. In microscopic identification the cell structure is enlarged from 40 to 100 times, thus furnishing the most positive means of wood identification.

Wood is usually identified from three different planes of a section of wood as shown in fig. 1. The face that is exposed

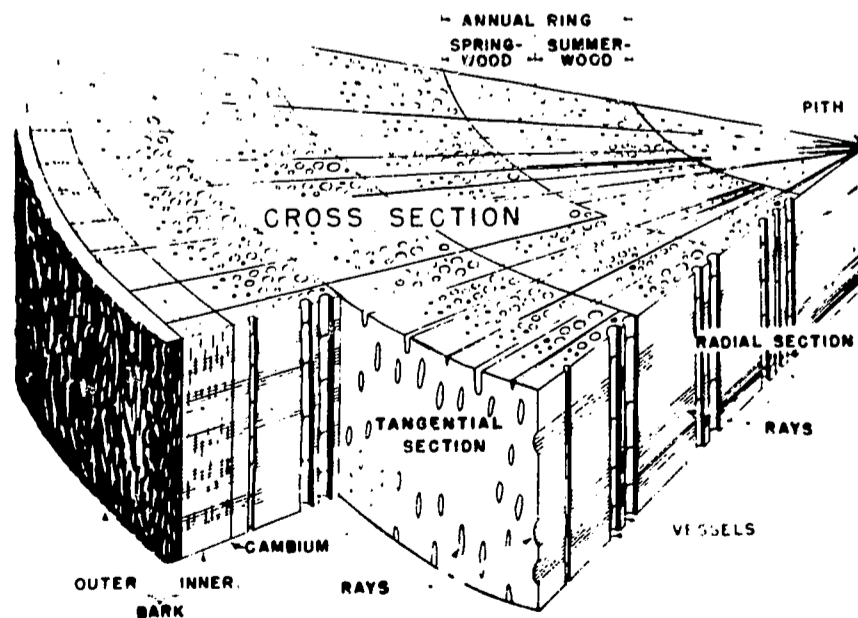

fig. 1

when wood is cut or sawed at right angles to the grain is the transverse surface or cross section. The end grain is visible in this plane and is the surface most often used in wood identification. The radial and tangential surfaces sections are at right angles to the transverse surface. A truly radial section would pass from the bark through the pith of the tree, following a radius of a cross section of the log. The tangential face of wood is exposed when the bark is peeled from a tree (2: 34).

A cross section of a tree shows several parts that can be identified with the eye in wood identification. (fig. 2) The outer bark, which is protecting the tree, is the dead, corky part that varies in thickness with the kind of tree and its age. The inner bark or phloem carries the food made in the leaves down to branches, trunk and roots. Just inside the inner bark the cambium layer is found. It is the soft, microscopic pitch-like material in which cell formation takes place to form wood on the inside and phloem or inner bark on the outside.

The wood itself is the part of the tree used to make lumber. It is divided into sapwood and heartwood. Sapwood contains living cells and has an active part in the life processes of the tree. It is located next to the cambium and functions in sap conduction up and down the trunk from the roots to the leaves. The sapwood may vary in thickness and in the number of growth rings it contains. It is the newer growth, usually lighter in color, that is actually the growing part of the tree. Normally there is less sapwood than heartwood.

The heartwood is generally darker in color because of the presence of resin and other materials. As far as the growth of the tree is concerned, the heartwood is dead as it consists of inactive cells formed by changes in the living cells of the inner sapwood rings. Some trees have pores tightly plugged by tyloses as is seen in white oak. The only active part of the heartwood is in the actual physical support of the crown. It is, however, more resistant to decay than the sapwood. Heartwood is more valuable commercially and most timbers with which we are familiar come from this colored, denser wood. (6:35)

The pith is the small center core of a tree. Most branches originate at the pith, and their bases are intergrown with the wood of the trunk as long as they are alive.

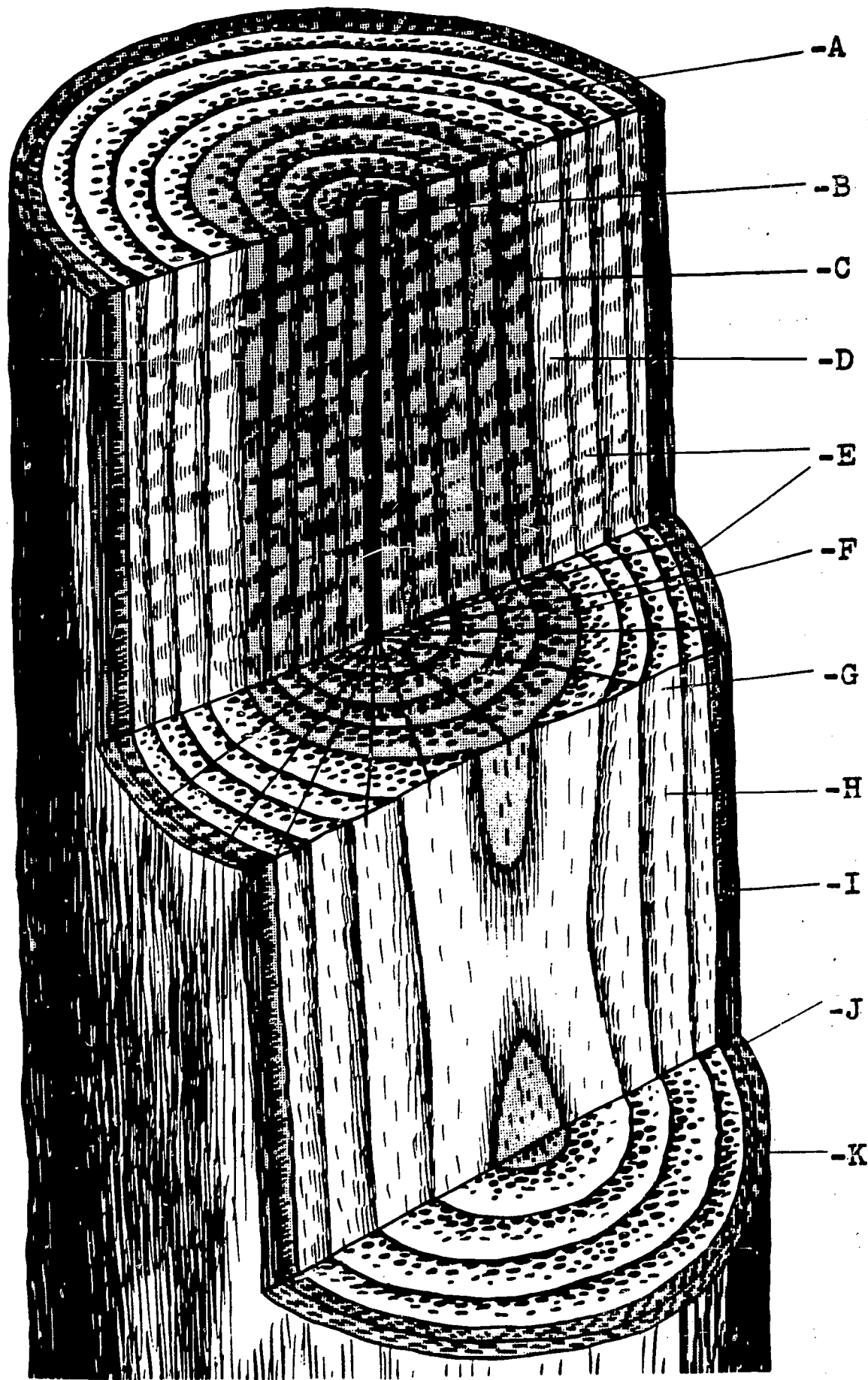

Fig. 2 Cross section of a tree

- |                                |               |               |
|--------------------------------|---------------|---------------|
| A. Annual Ring                 | B. Pith       | C. Summerwood |
| D. Springwood                  | E. Rays       | F. Heartwood  |
| G. Sapwood (Xylem)             | H. Rays       | I. Cambium    |
| J. Inner Bark (Bast or Phloem) | K. Outer Bark |               |



Radiating outward from the center of a tree are medullary ray cells. These are visible with the eye in some species while in others, some magnification is necessary. Medullary rays, also called rays, store and conduct food horizontally, in the tree. The rays are most easily seen on quarter sawed lumber.

Each year as a tree grows it usually puts on an early inner growth ring called springwood or early wood. An outer part formed later in the growing season is referred to as summerwood or late wood. The actual time of formation of these two parts of ring may vary with environmental and weather conditions. Springwood is usually characterized by cells having relatively large cavities and thin walls. Summerwood cells have smaller cavities and thicker walls. The change from springwood to summerwood may be gradual or abrupt, this depending on the kind of wood and the growing conditions at the time it was formed. In the tropics where growth and wood formation are more or less continuous, growth layers are not formed. The wood formed appears quite homogeneous. (4:95)

Trees are a division of seed plants termed by botanists as spermatophytes. These are divided into two groups: endogens (inward-growing) and exogens (outward-growing) trees. The endogens (inward-growing trees) have little commercial value as most of their growth takes place inwardly in a hollow trunk. Exogenous trees (outward-growing) are the valuable lumber producing trees. These may be divided into two classes: angiosperms and gymnosperms.

Angiosperms are called hardwoods or deciduous woods. The term deciduous means that they shed their leaves annually. Although lumber is usually specified as either soft or hard, these terms do not refer to the actual softness or hardness of the wood itself. The hardwoods are obtained from broad-leaved trees such as elm, oak, and poplar. In almost all cases the leaves are broad and deciduous in the temperate zones. Hardwoods are designated as porous woods based on the fact that porous woods possess vessels or ducts extending along the grain. (fig. 3) The vessels form the main arteries in the movement of the sap. They appear as pores and are often visible with the naked eye on the transverse surface. In hardwoods, when the pores are larger or more abundant in one portion of a growth ring than in another, the wood is called ring porous. This characteristic is caused when a hardwood tree grows more rapidly in the early or springwood than it does in the late growth or summerwood. When this takes place the early growth is softer and coarser, the pores are larger and the growth is much thicker.

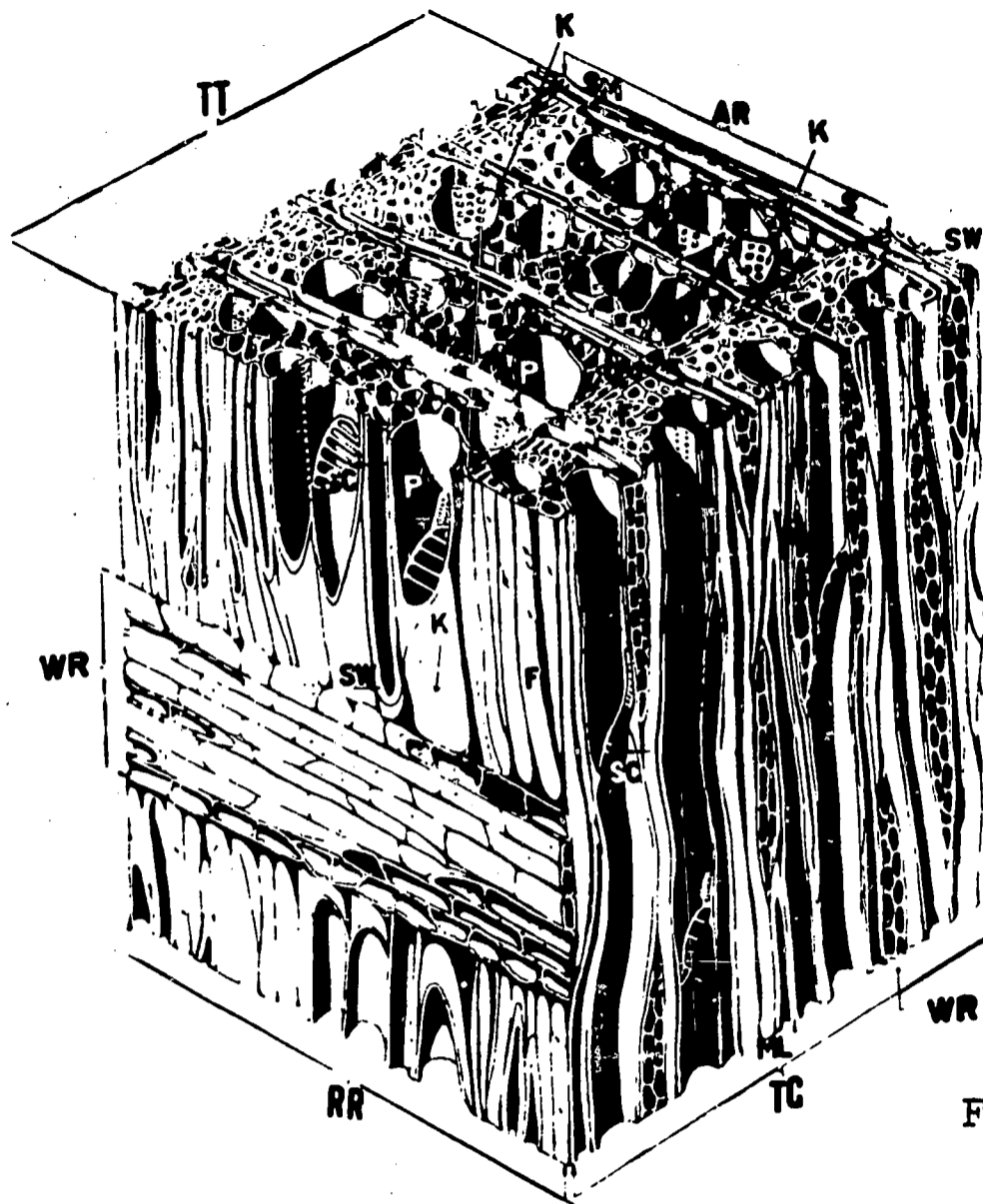

AR-Annual Ring  
 F-Wood Fibers  
 K-Pits  
 ML-Middle Lamella  
 P-Pores or vessels  
 RR-Verticle plans parallel  
 to the radius  
 S-Springwood or earlywood  
 SC-Grating  
 SM-Summerwood  
 TT-Horizontal plane-top  
 surface  
 WR-Wood rays

Fig. 3 Hardwood

Many of the hardwoods are classified as close grained woods. They have pores that are of fairly even sizes and are well distributed throughout the growth ring. These woods, such as maple or birch, seldom require filling to produce a good end product; they are referred to as diffuse porous. Diffuse porous means that the growth was uniform throughout the growing season and no significant difference can be seen in the early growth and the late growth (4: 39). All woods are porous in the broad sense of possessing air space; these air spaces must not get confused with vessels in hardwoods or tracheids in softwoods.

The softwoods also known as coniferous woods, are produced by "cone bearing" trees. Usually these are evergreen trees such as the firs, pines, cedars, redwoods, spruces and hemlocks; the exceptions to these are cypress, larch and tamarack. A softwood tree has needlelike, linear, awlshaped, or scalelike leaves and the seeds are borne either in cones

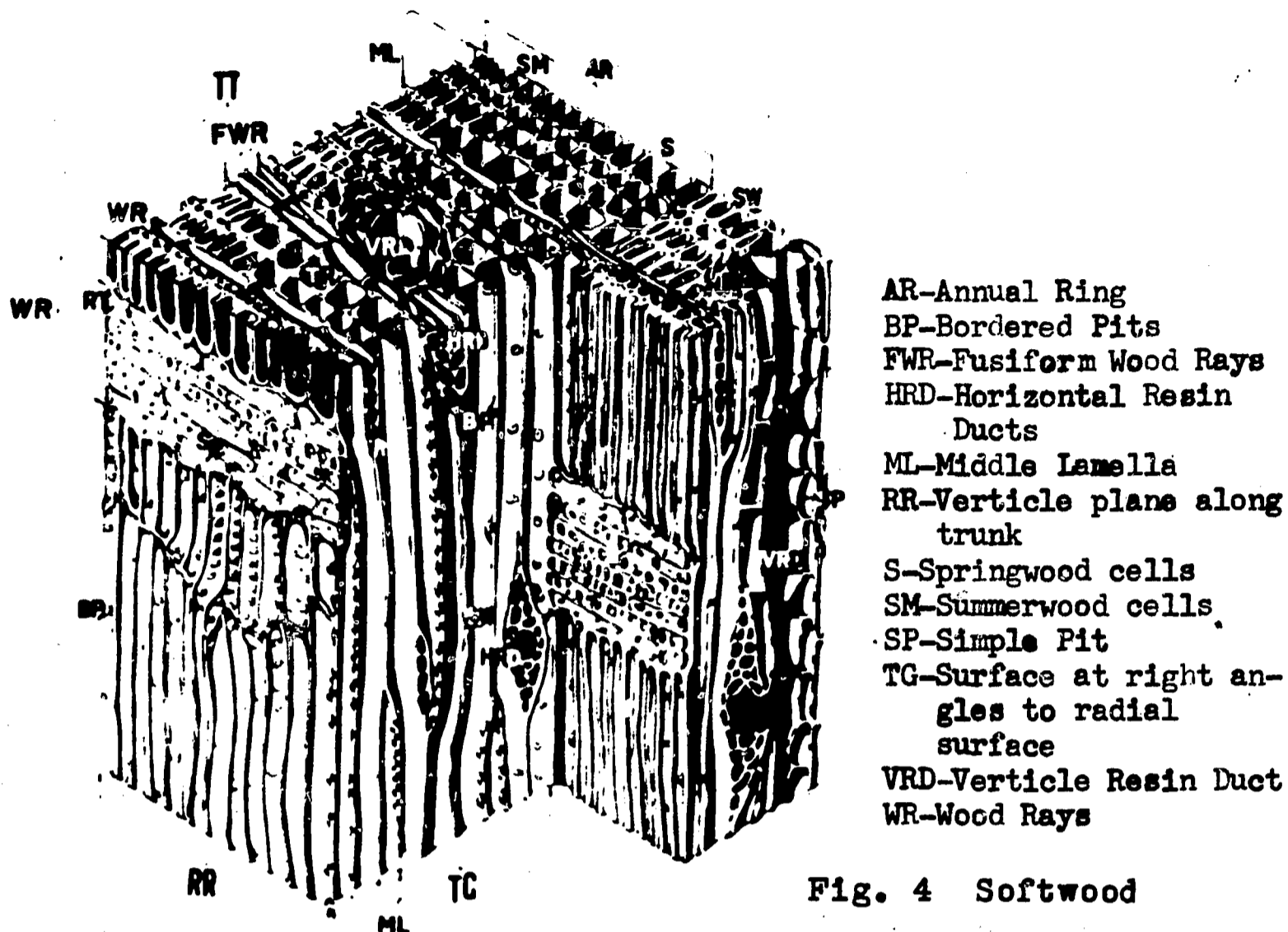

Fig. 4 Softwood

in axil of a cone, or naked. Softwoods are designated non-porous as they have no vessels or ducts which appear with the naked eye on the transverse surface. When the transverse surface of a coniferous wood is viewed under a lens (fig. 4) it appears to consist of uninterrupted radial rows of cells called tracheids. The tracheids conduct the sap longitudinally in the softwood tree. Another identifying characteristic in softwoods is the presense of resin ducts in some species. (17: 15)

Resin ducts are many times confused with vessels or pores that are found in hardwoods. These ducts are in reality tubular intercellular spaces sheathed by secreting cells. Resin ducts or canals are found in pine, spruce, larch or tamarack, and douglas fir; these serve to distinguish from those of other domestic conifers. Normal resin ducts extend both along the grain and also across the grain and may vary greatly in size. Sometimes ducts or canals may be found, as a result of injury, in woods normally devoid of canals. This type of a canal is called a traumatic canal and can be found along the grain in hemlock, fir and redwood. The presence of ducts or canals as normal structures indicates that the wood in question must belong to one of four species. (2: 50)

## SOFTWOODS

The term, softwood, refers to wood from cone bearing trees also called conifers. As a group they are characterized by scalelike leaves or needles and cones. The classification is a botanical one and does not indicate the degree of hardness or softness of the wood.

Softwood is used extensively by the pulp and paper industry. Wood for most building materials also comes from this group. In general, softwoods are seldom used for furniture, but may be used in interiors for cabinets, paneling, built-ins, and trim.

Softwoods include douglas and white fir, redwood, cypress, larch, hemlock, western red cedar, the spruces and the pines. Several kinds may be found under each of these species. For example, pines may be shortleaf, longleaf, loblolly, slash, ponderosa, northern, Idaho white, red, sugar, lodgepole, or jack.

Vast amounts of softwoods are cut and used in this country each year. Their special identifying characteristics have been well catalogued by Panshin (2: 441) and others.

## WESTERN RED CEDAR

General Characteristics

Sapwood - nearly white, narrow.

Heartwood - reddish or pinkish brown to dull brown.

Wood - characteristic sweet, fragrant cedary odor and faint bitter taste.

Growth Rings - distinct and generally quite conspicuous.

Parenchyma - not visible or barely distinct with a hand lens as a narrow line in the late wood.

Rays - fine, close, inconspicuous fleck on the quarter surface.

Minute Anatomy - Tracheids medium coarse, up to 45 microns in diameter. Bordered pits in one or two rows on the radial walls. Tangential pitting present in the last two rows of the late wood tracheids.

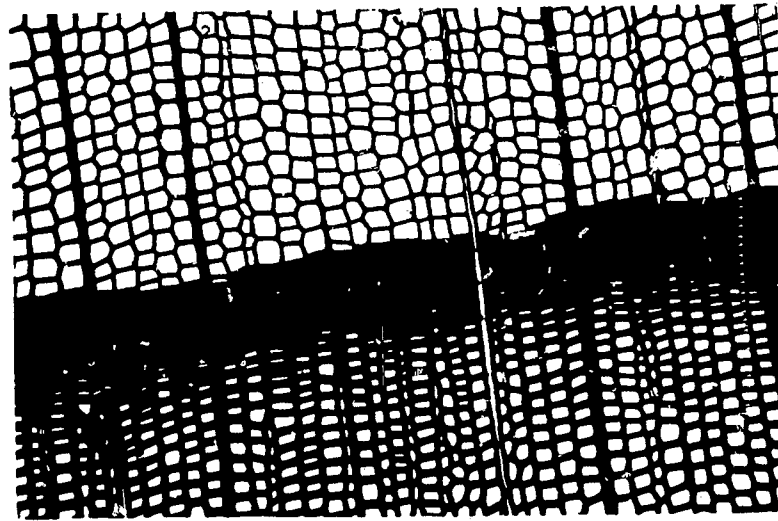

**BALD CYPRESS**General Characteristics

Sapwood - pale yellowish white, merging gradually into the heartwood.

Heartwood - variable in color ranging from yellow to dark brown.

Wood - does not impart taste, odor, or color to food.

Growth Rings - distinct, early wood zone, narrow to wide, usually several times wider than late wood.

Parenchyma - abundant, present in every growth ring.

Rays - rather coarse for a coniferous wood.

Minute Anatomy - tracheids up to 70 microns in diameter, frequently bordered pits appearing in one to four rows on the radial walls, pitting present in the last few rows of late wood tracheids.

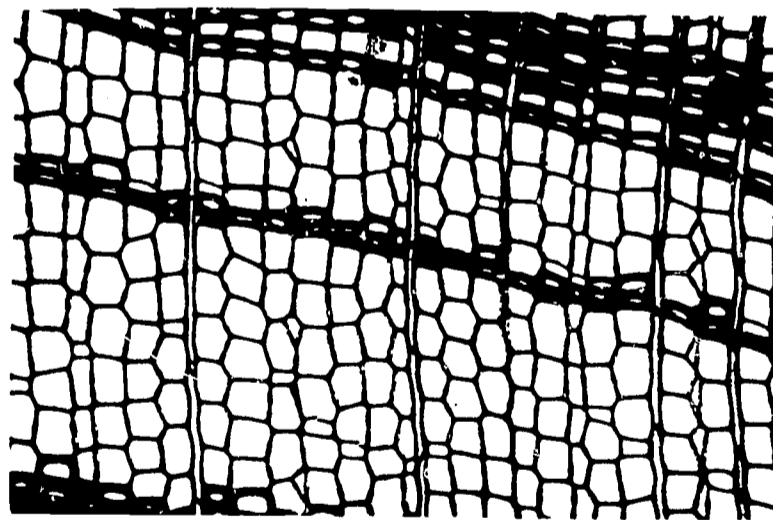

## DOUGLAS FIR

General Characteristics

Sapwood - whitish to pale yellowish or reddish white.

Heartwood - ranging from yellowish or pale reddish yellow to deep red, the color varying greatly in different samples.

Wood - has characteristic resinous odor when fresh, without characteristic taste, usually straight and even grained.

Growth Rings - very distinct, frequently wavy. Early wood zone usually several times wider than the band of late wood, transition from early to late wood generally abrupt.

Parenchyma - not visible.

Rays - not visible to the naked eye.

Resin Canals - present, longitudinal and transverse.

Minute Anatomy - tracheids up to 55 microns in diameter, characterized by fine, close bands of spiral thickening. Bordered pits in one row or occasionally paired on the radial walls. Tangential pitting present in the last few rows of late wood tracheids.

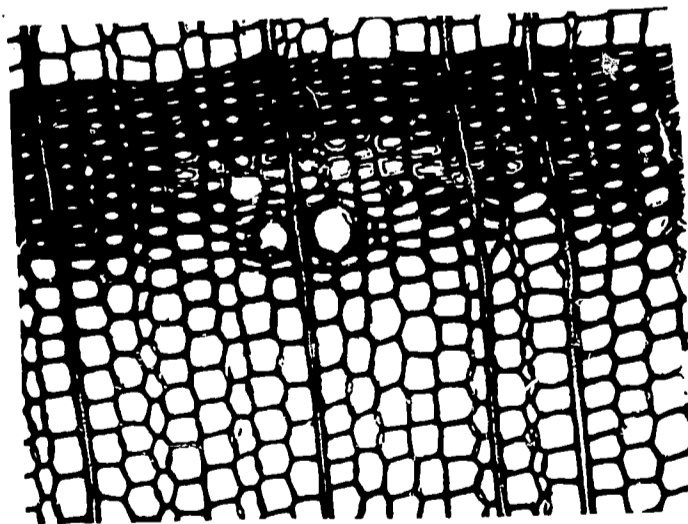

## PONDEROSA PINE

General Characteristics

Sapwood - nearly white to pale yellowish, wide, often composed of 80 or more rings.

Heartwood - yellowish to light reddish or orange brown.

Wood - distinct, non-characteristic, resinous odor without characteristic taste.

Growth Rings - distinct, inconspicuous to conspicuous.

Parenchyma - not visible.

Rays - very fine, not visible to the naked eye except where they include a transverse resin canal.

Resin Canals - present, longitudinal and transverse.

Minute Anatomy - Tracheids up to 60 microns in diameter, bordered pits in one row on the radial walls. (Resin cells with thin walled epithelium frequently occluded with tylosoids in the heartwood.)

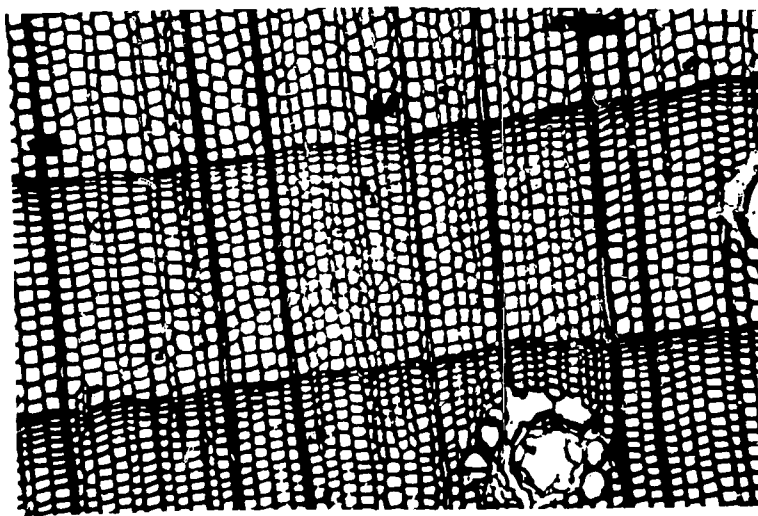



## SOUTHERN PINE

General Characteristics

Sapwood - nearly white to yellowish.

Heartwood - distinct, ranging through reddish brown or light brown to shades of orange and yellow.  
Resinous.

Wood - noncharacteristic, resinous odor; without characteristic taste.

Growth Rings - distinct, delineated by a pronounced band of darker late wood. Early zone varying from wide to very wide.

Parenchyma - not visible.

Rays - fine, not visible to the naked eye except where include a transverse resin canal.

Minute Anatomy - Tracheids up to 60 microns in diameter, bordered pits in one row or not infrequently paired on the radial walls. Resin canals with thin walled epithelium frequently occluded with tylosoids in the heartwood.

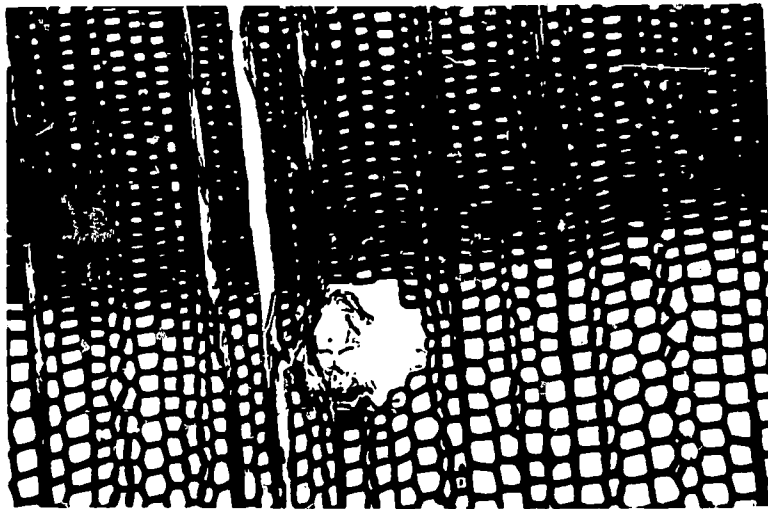

## SUGAR PINE

General Characteristics

Sapwood - white to pale yellowish white, frequently discolored by blue stain.

Heartwood - light brown to pale reddish brown, frequently discolored with brown stain.

Wood - noncharacteristic odor, often exuding a sugary substance when green.

Growth Rings - distinct, delineated by a narrow band of darker late wood at the outer margin. Early wood zone usually wide, appearing to occupy most of the ring.

Parenchyma - not visible.

Rays - very fine, not visible to the naked eye except where they include a transverse resin canal.

Minute Anatomy - tracheids up to 65 microns in diameter, bordered pit in one or two rows on the radial walls; tangential pitting present in the last few rows of late wood tracheids. Pits leading to ray parenchyma large, not infrequently three per ray crossing.

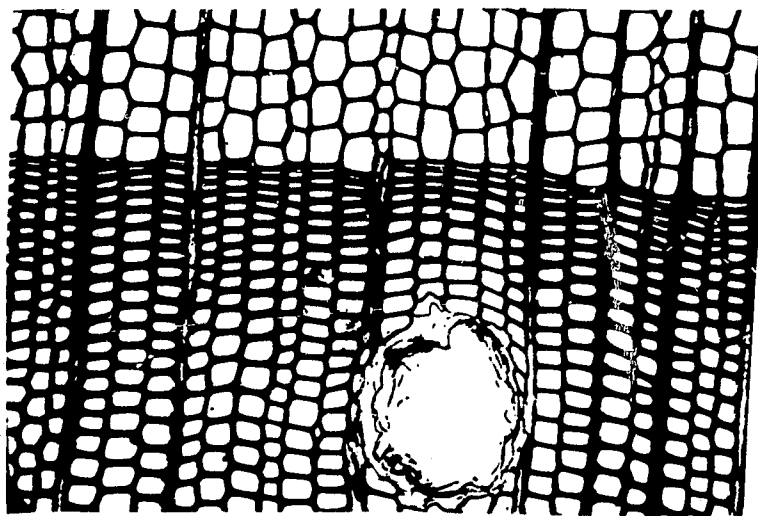

## REDWOOD

General Characteristics

Sapwood - narrow, almost white.

Heartwood - varies in color from light cherry to dark mahogany.

Wood - without characteristic odor or taste.

Growth Rings - distinct, delineated by a band of darker late wood. Late wood zone distinct to the naked eye, darker and denser than the early wood.

Parenchyma - abundant, present in every growth ring. Cells scattered, readily visible in the sapwood with a lens, and sometimes to the naked eye.

Rays - coarse for a coniferous wood, lighter than the background in the heartwood, generally visible to the naked eye.

Minute Anatomy - tracheids up to 80 microns in diameter, bordered pits in at least two rows on the radial walls, tangential pitting present in the last few rows of late wood tracheids.

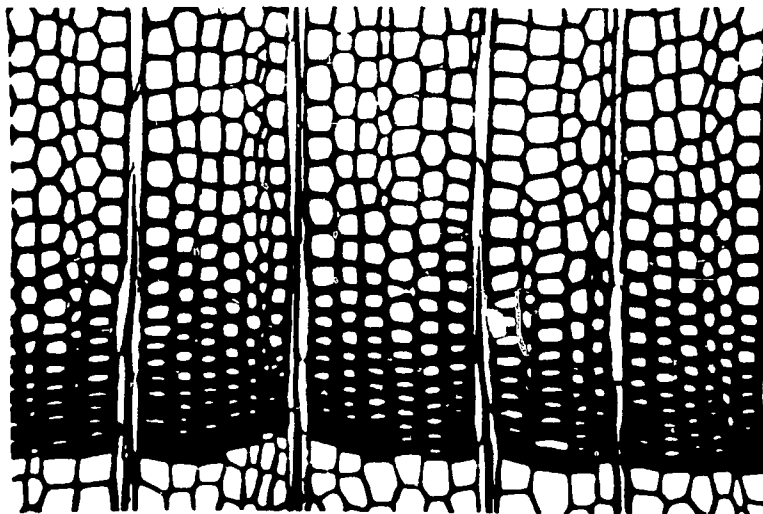

## SITKA SPRUCE

General Characteristics

Sapwood - creamy white to light yellow (5: 87)

Heartwood - light pinkish yellow to pale brown with purplish cast.

Wood - more or less lustrous, without characteristic odor or taste.

Growth Rings - distinct, delineated by a band of darker late wood. Early wood zone usually occupying one-half to two-thirds of the ring.

Parenchyma - not visible.

Rays - very fine, not visible to the naked eye except where they include a transverse resin canal.

Resin Canals - present, longitudinal and transverse. Longitudinal canals fairly large, appearing as white flecks in the dark heartwood to the naked eye.

Minute Anatomy - tracheids up to 55 microns in diameter, bordered pits in one row or rarely paired on the radial walls. Tangential pitting present in the last few rows of late wood tracheids.

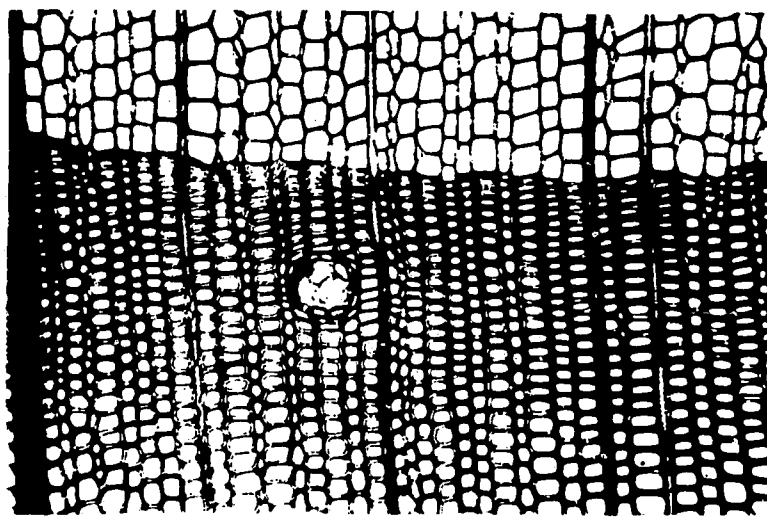

## HISTORY OF THE USE OF FINE HARDWOODS

In all the eras of our civilization, hardwoods have been prized for their color and texture and the brilliance with which they take and hold a finish. The variety of color alone to be found among the more familiar hardwoods ranges from the pale creamy white of holly to the almost pure black of African ebony.

In this century for the first time in history, wood is not only a natural wonder, but so vastly improved in use by man as to be quite different in its function, beauty, and durability from what it was even fifty years ago.

American walnut, our most popular furniture wood, is also highly regarded in Europe. Cherry, maple, oak, pecan, butternut, and birch are the next most popular American furniture woods.

Mahogany from Tropical America and Africa has been a popular imported hardwood in the United States since the early 18th Century.

Walnut began to be popular in England, where oak had been supreme for centuries, about the time of Queen Anne, in the early 17th Century. Through the years it has been used in many different furniture styles, both here and in Europe. On both continents it is still a popular wood with designers of modern or contemporary furniture. (7)

AMERICAN BASSWOOD - *Tilia Americana*  
WHITE BASSWOOD - *Tilia Heterophylla*

General Characteristics

Sapwood - Whitish to creamy white or pale brown.

Heartwood - Pale brown, sometimes with a reddish tinge.

Wood - Faint odor on freshcut surface. Tasteless. Straight grained, light. S.G. 0.32 green, 0.40 oven-dry. Soft.

Growth Rings - Fairly distinct.

Pores - Numerous, small, distinctly visible with a hand lense.

Parenchyma - Not distinct or barely visible with a hand lense. Banded.

Rays - Variable in width.

Minute Anatomy

Vessels - Moderately few to very numerous, the largest small to medium.

Parenchyma - Abundant, marginal and apotracheal. Banded.

Fiber Tracheids - Thin walled, medium to very coarse.

Rays - Unstoried or rarely somewhat storied. (3: 564-566)

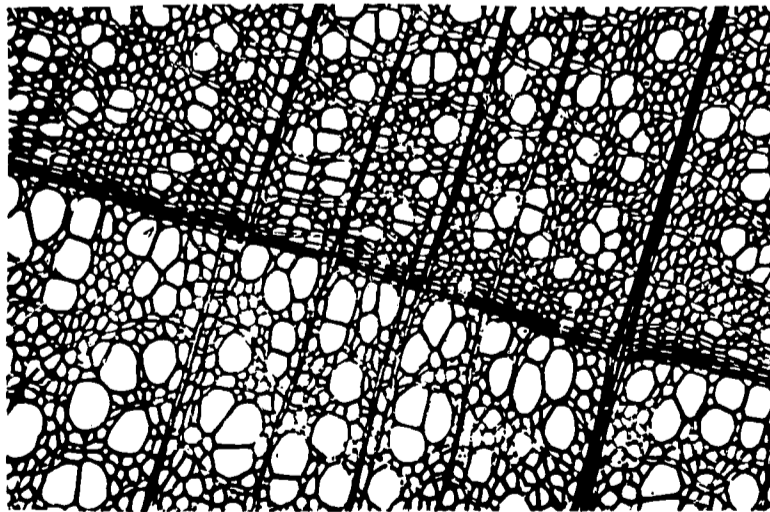

BIRCH - *Betula Alleghaniensis*General Characteristics

Sapwood - Whitish, pale yellow, or light reddish brown.

Heartwood - Light to dark brown or reddish brown.

Wood - No odor or taste, straight-grained, moderately heavy to very heavy S.G. 0.45 - 0.60 green, 0.55 to 0.71 oven-dry. Moderately hard to hard.

Growth Rings - Frequently not very distinct without a lens, delineated by a fine line of denser fibrous tissue at the outer margin.

Pores - Appearing as whitish dots to the naked eye, the larger obviously wider than the widest rays, nearly uniform in size and evenly distributed throughout the growth ring.

Parenchyma - Not visible.

Rays - Fine, visible with hand lens.

Minute Anatomy

Vessels - Small to medium, few to moderately numerous.

Parenchyma - Apotracheal - diffuse.

Fiber Tracheids - Thin to moderately thick walled. Medium to coarse.

Rays - Unstoried, homocellular. (3: 510-512)

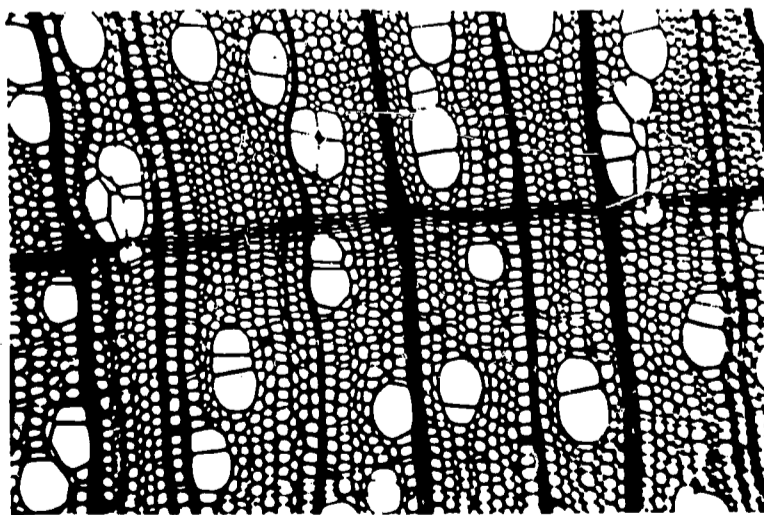

CHERRY - *Prunus Serotina*General Characteristics

Sapwood - Whitish to light reddish brown.

Heartwood - Light to dark reddish brown.

Wood - No odor or taste, straight grained, moderately hard, moderately heavy, S. G. 0.47 green, 0.53 oven-dry.

Growth Rings - Fairly distinct.

Pores - Small, indistinct to the naked eye. Those at the beginning of the ring somewhat larger, elsewhere quite uniform in size and fairly evenly distributed.

Parenchyma - Not visible

Rays - Visible to naked eye, green canals sometimes present.

Minute Anatomy

Vessels - Moderately numerous to very numerous, the largest small. Gummy infiltration occasionally present.

Parenchyma - Very sparse.

Fiber Tracheids - Thin to thick walled, medium to coarse.

Rays - Unstoried (3: 547-549)

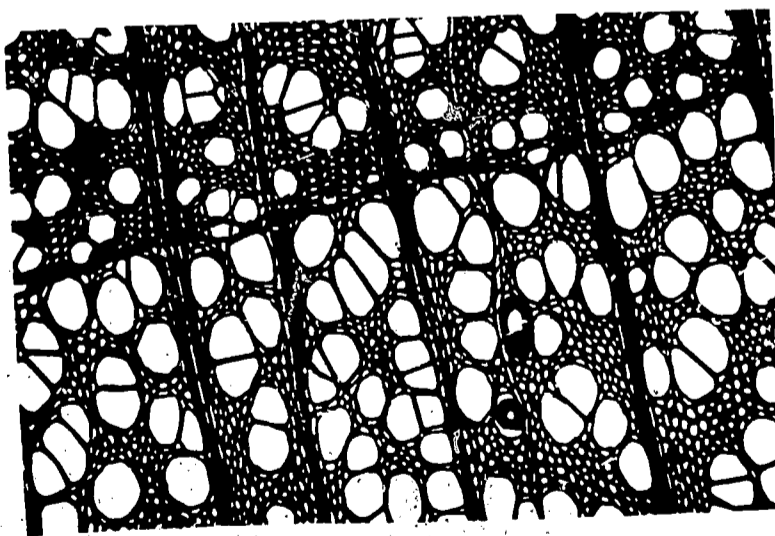



HARD MAPLE - Sugar-Acer Saccharum  
Black-Acer Nigrum

General Characteristics

Sapwood - White with a reddish tinge.

Heartwood - Uniform light reddish brown.

Wood - No odor or taste, straight grained usually heavy,  
S.G. 0.52 - 0.56 green, 0.62 - 0.68 oven-dry, hard.

Growth Rings - Usually fairly distinct.

Pores - Small, indistinct without a hand lens.

Parenchyma - Not visible.

Rays - Two widths. Broad rays visible to naked eye.  
Narrow rays barely visible with a hand lens.

Minute Anatomy

Vessels - Few to moderately numerous, the largest small.

Parenchyma - Sparse.

Fibers Libriform and Fiber Tracheids - Thin to moderately  
thick-walled, fine to coarse.

Rays - Unstoried. (3: 556-568)

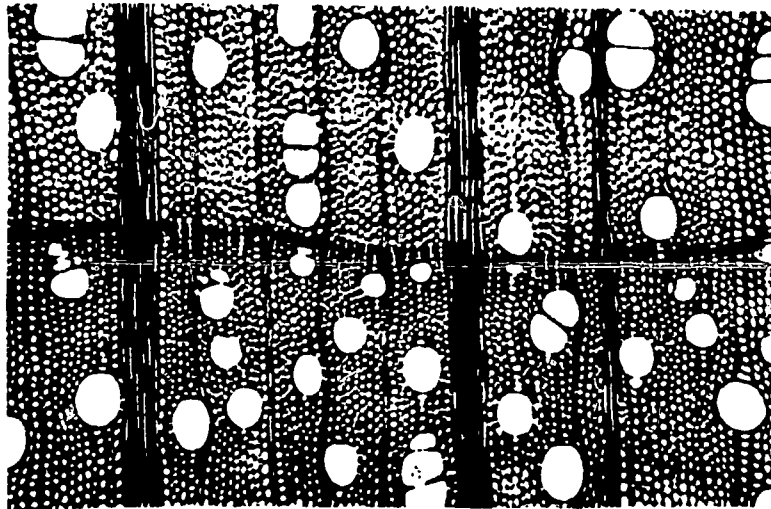

**SOFT MAPLE:** Red Maple - *Acer Rubrum*  
Silver Maple - *Acer Saccharum*

General Characteristics

Sapwood - White

Heartwood - Light brown, sometimes with a grayish or greenish tinge.

Wood - No odor or taste. Straight grained usually. Moderately heavy. S.G. 0.44 - 0.49 green, 0.51 - 0.55 ovendry. Moderately hard to hard.

Growth Rings - Not very distinct.

Pores - Small, indistinct without a hand lens.

Parenchyma - Not visible.

Rays - Visible to the naked eye.

Minute Anatomy

Vessels - Moderately few to moderately numerous. The largest small.

Parenchyma - Sparse.

Fibers Libriform and Fibers Tracheids - Thin to moderately thick-walled. Medium to coarse.

Rays - Unstoried. (3: 560-561)

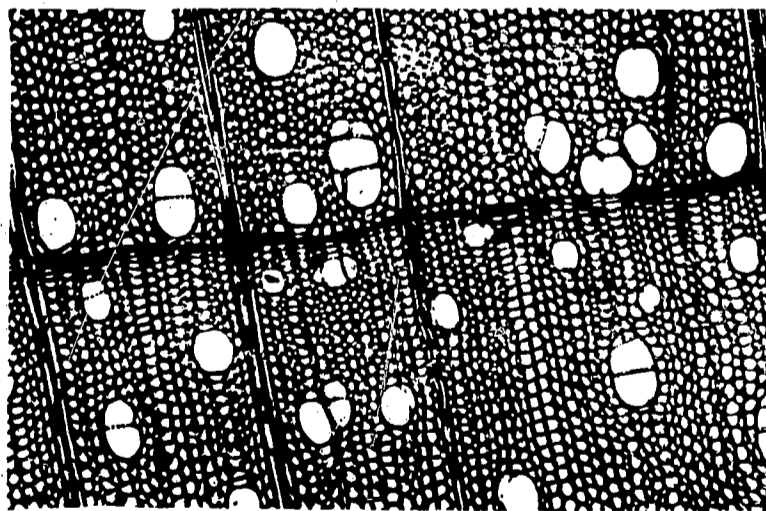

RED OAK - Quercus RubraGeneral Characteristics

Sapwood - Whitish to grayish or pale reddish brown.

Heartwood - Pinkish to light reddish brown, occasionally light brown.

Wood - No odor or taste, generally straight grained, heavy to very heavy. S.G. 0.52 - 0.61 green, 0.62 - 0.76 oven-dry. Hard to very hard.

Growth Rings - Very distinct.

Early Wood Pores - Large, visible to naked eye, few or no tyloses in the heartwood.

Late Wood Pores - Abundant, small, indistinct or barely visible to the naked eye.

Parenchyma - Visible with a hand lens.

Rays - Two types, broad and narrow. Broad rays visible to naked eye. Narrow rays much more numerous than broad rays, but indistinct without magnification.

Minute Anatomy

Vessels - In late wood few, largest early wood vessels large to extremely large.

Vasicentric Tracheids - Present intermingled with parenchyma.

Parenchyma - Abundant, paratracheal, intermingled with tracheids, usually banded.

Fibers Libriform and Fiber Tracheids - Medium thick to thick walled.

Rays - Unstoried, homocellular. (3: 522-525)

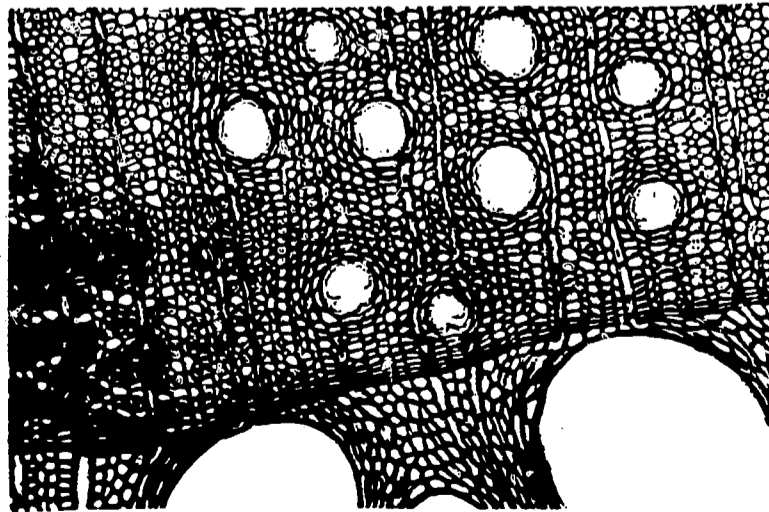

## WHITE OAK - *Quercus Alba*

### General Characteristics

Sapwood - Whitish to light brown.

Heartwood - Rich light brown to dark brown.

Wood - No odor or taste, usually straight grained, heavy to very heavy. S.G. 0.55 - 0.64 green, 0.66 - 0.79 oven-dry. Hard to very hard.

Growth Rings - Very distinct except in slow-grown stock.

Early Wood Pores - Large, visible to naked eye.

Late Wood Pores - Numerous, small, not sharply defined with a hand lens.

Parenchyma - Visible with a hand lens.

Rays - Broad rays very conspicuous to the naked eye, narrow rays much more numerous but indistinct without magnification.

### Minute Anatomy

Vessels - Late wood few to numerous; largest early wood vessels large to extremely large.

Vasicentric Tracheids - Present, intermingled with parenchyma.

Parenchyma - Abundant, paratracheal, opotracheal - diffuse and usually banded.

Fibers Libriform and Fiber Tracheid - Medium thick to thick walled, frequently gelatinous.

Rays - Unstoried and homocellular. (3: 525-528)



YELLOW POPLAR - Libiodendron TulipiferaGeneral Characteristics

Sapwood - Whitish, often variegated or striped.

Heartwood - Ranges from clear yellow to tan or greenish brown, often marked with shades of purple, dark green, blue and black.

Wood - No odor or taste, straight grained, moderately light. S.G. 0.38 green, 0.43 oven-dry. Moderately soft.

Growth Rings - Distinct

Pores - Not visible without a lens, wood diffuse, porous.

Parenchyma - Marginal, the line plainly visible to the naked eye.

Rays - Distinct to the naked eye.

Minute Anatomy

Vessels - Moderately numerous to numerous, the largest small to medium.

Parenchyma - Several, seriate.

Fiber Tracheids - Thin to moderately thick walled, medium to coarse.

Rays - Unstoried or rarely somewhat storied. (3: 539-541)

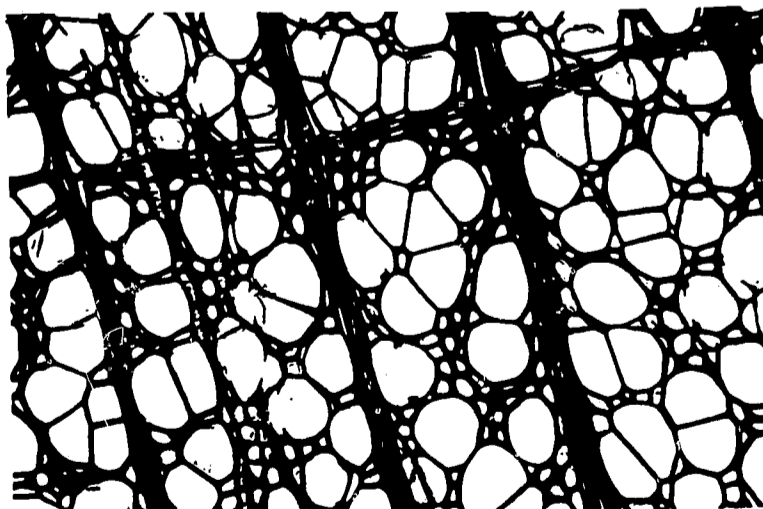

## BLACK WALNUT (*Juglans Nigra*)

### General Characteristics

Sapwood - Whitish to yellowish brown. In the trade commonly darkened by steaming or staining to match the heartwood.

Heartwood - Light brown to rich chocolate or purplish brown, the lighter shades from trees grown in the open.

Wood - Mild characteristic odor when worked, tasteless, straight or irregular grained. Heavy, S.G. 0.51 approx. green, 0.56 oven-dry. Hard.

Growth Rings - Distinct, delineated through an abrupt difference in size between the pores of the outer late wood and those in the early wood of the succeeding ring.

Pores - Scattered, those in early wood readily visible, decreasing gradually in size toward the outer margin of the ring. Tylos fairly abundant.

Parenchyma - Barely visible with hand lens, arranged in fine, numerous, continuous, or broken tangential lines.

Rays-Fine - Indistinct without a hand lens.

### Minute Anatomy

Vessels - Very few, the largest large to very large.

Parenchyma - Frequently crystalliferous.

Fibre Tracheids - Thin to moderately thick walled.

Rays - Ray-vessel pitting similar to intervessel type.  
(3: 497-498)

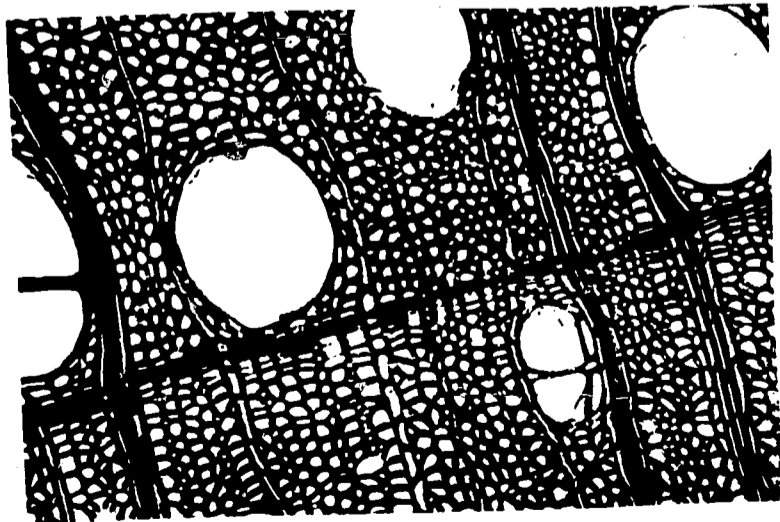

## THE CHEMISTRY OF WOOD

Chemically, wood is not a single substance; rather it is a complete aggregate of compounds, the nature of which is still inadequately understood by wood chemists. (4:36)

It is convenient to segregate the chemical components of wood into two major groups.

1. Cell-Wall Components - These are chemical compounds that form an integral part of the cell walls of wood; they are mainly organic in nature. The cell wall components cannot be removed by the action of any solvent without destroying the physical structure of wood. (3: 721)
2. The Extraneous Components - These substances, also called extractives and infiltration substances, are not an integral part of the cell wall; they can usually be removed by the use of a suitable solvent without affecting either the chemical composition of the wood substance or the physical structure of the cell wall. (3: 722)

### THE CELL-WALL COMPONENTS OF WOOD

The organic cell-wall components of wood are of two general classes; carbohydrates and the compounds known collectively as lignin. The carbohydrates consist of cellulose and hemicelluloses; the hemicelluloses, in turn, are composed of pentosans, hexosans, and uronic acid - containing components. Lignin constitutes the noncarbohydrate portion of extractive free wood. It is a complex of noncarbohydrate material of unknown chemical composition. (3: 723)

### CELL-WALL CARBOHYDRATES

Carbohydrates are chemical compounds, consisting of carbon, hydrogen, and oxygen, that form the supporting framework of plant tissue, including wood, in the same manner as proteins make up the tissues of animals. Carbohydrates also are present as reserve materials in plant cells and are therefore a source of energy. (3: 724)

Cellulose - About 99 per cent of the dry weight of wood consists of cellulose and related substances, and of lignin. Cellulose is a carbohydrate, as are sugar and starch; it contains the chemical elements carbon, hydrogen, and oxygen; the hydrogen and oxygen being present in the same proportions as in water. (4: 38)

Technically, the term signifies the residues that result when vegetable materials are pulped. Pulps are not pure cellulose because they also contain variable amounts of non-cellulosic cell-wall constituents. Chemically pure cellulose is known as a polysaccharide, which is insoluble in water, organic solvents, and dilute acids and alkalies. (3: 725)

Hemicelluloses - Those cell-wall components which can be extracted from wood with cold or hot dilute alkalies and that can be hydrolyzed into component sugar and sugar acids by dilute acids. One type is represented by the polysaccharides which form a part of the system that encrusts and interpenetrates the cellulosic framework of the cell wall. The other type consists of celluloses and noncellulosic polysaccharides that form a part of the cellulosic fabric proper. (3: 723)

### LIGNIN

Lignin is the organic noncarbohydrate portion of extractive-free wood; its chemical and physical constitution is still unknown in spite of more than a 100 years of extensive research. (3: 730)

This is due in part to its extreme chemical complexity, and to the lack of conclusive proof that the lignin separated by chemical means from the cell-wall constituents with which it is intimately associated, is identical with natural lignin. The lignin in hardwoods is believed to be different structurally from that in softwoods.

Lignin is composed of carbon (61-65 percent) hydrogen (5-6 percent) and oxygen (30 percent). It is the manner in which these three elements are chemically united, and their proportions, that makes lignin differ from cellulose. Lignin is the major constituent remaining in woody tissues after the cellulose has been removed. (4: 38)

Two methods of removing lignin from the other components of the cell wall are:

- (1) those which depend on the removal of the cellulose and other carbohydrates, generally by means of a strong mineral acid, leaving the lignin as an insoluble residue; and
- (2) those which are based on the dissolution of the lignin with an alkali or some other delignifying agent, leaving behind the cellulose and the other carbohydrates that are associated with it (3: 734)



The lignin content of softwoods ranges from 25 to 35 percent; that of hardwoods is usually lower, varying from 17 to 25 percent.

#### THE EXTRANEOUS COMPONENTS OF WOOD

These are substances which can be removed by extraction with neutral solvents such as water, alcohol, benzol, ether, and choloform, or by volatilization with steam. They also include substances which appear to be distinct from the cell wall when thin sections of wood are examined with a microscope. The natural durability of wood is closely linked with the toxicity of its extractives. (3: 737)

Extractives are grouped on the basis of chemical similarities into;

- (1) Volatile oils, resin acids, and fats
- (2) Tannins and dyestuffs
- (3) Carbohydrates
- (4) Miscellaneous substances (3: 739)

## WOOD PRESERVATIVES

The primary objective of the preservative treatment of wood is to increase the life of the material in service, thus decreasing the cost of the product and avoiding the need of frequent replacements in permanent and semi-permanent construction.

Wood preservatives increase the resistance to decay, repel the attracts of teredos and other live woodbores, and help to retard fires.

### A. Classes of wood preservatives:

1. Oils, such as creosote and petroleum solutions of pentachlorophenol.

Coal tar creosote -- is the most important and most generally useful wood preservative. Its advantages are:

- a. high toxicity to wood destroying organisms.
- b. relative insolubility in water and low volatility which impart to it a great degree of permanence under the most varied use conditions.
- c. ease of application.
- d. ease with which depth of penetration can be determined.
- e. general availability and relatively low cost.
- f. long record of satisfactory use (24: 400)

Pentachlorophenol solutions and copper naphthenate solutions -- these preservatives were first used primarily for surface applications. The chlorinated phenols in volatile light-colored solvents, such as mineral spirits, were first used for window sash and millwork that required a clean, nonsmelling and paintable treatment.

Service and field tests on wood treated with petroleum oils containing five per cent of pentachlorophenol or copper naphthenate equivalent to 0.5 per cent or more of copper

metal show that these preservatives provide a high degree of protection against decay fungi and termites when the wood is properly treated. (24: 404)

2. Water borne salts that are applied as water solutions.

Water borne salts -- Wood preservatives used in water solution include zinc chloride, chromated zinc chloride, acid copper chromate, zinc arsenate, and chromated copper arsenate. These preservatives are employed principally in the treatment of wood for uses where it will not be in contact with the ground or water or where the treated wood requires painting.

Zinc chloride and chromated zinc chloride are frequently used as fire retardants for wood, but at retentions higher than those used only for wood preserving purposes.

#### B. Preparation of Timber for Treatment.

1. Peeling.

All timber should be peeled before seasoning because bark retards the drying of the wood, harbors insects, and favors decay infection in the sapwood (22: 33).

2. Seasoning.

For treatment with water borne preservatives by certain diffusion methods, the wood should be as green and as full of water as possible. For treatment by other methods, however, and particularly for treatment with preservative oils, seasoning before treatment is desirable (24: 410).

Some of the more important considerations in air seasoning include species and size of timber, proportion of sapwood, time of cutting, peeling, climatic conditions, locality in which the timber is seasoned, and method of piling (24: 32). It is not uncommon in commercial practice to air dry large timbers for 8 to 12 months.

3. Incising.

Wood that is resistant to penetration by preservatives is often incised before treatment to permit deeper and more uniform penetration (22: 411).

#### 4. Cutting and Framing.

All cutting, framing, and boring of holes should be done before treatment. Cutting into the wood in any way after treatment will frequently expose the untreated interior of the timber and permit ready access to decay fungi or insects.  
(22: 411)

#### 5. Conditioning Process

Frequently timbers must be treated without waiting for them to air season. This is necessary in some cases because of unfavorable climatic conditions that make air-seasoning a decay hazard, or because in other cases, rush orders make it necessary to treat the timbers soon after they are cut. When green material is to be treated, it is customary to control the wood by a special heat treatment so that it can be penetrated with the preservative. The conditioning treatment generally removes a substantial amount of moisture from the timber and also heats the wood to a more favorable treating temperature.

Two methods for accomplishing this conditioning have been extensively used in this country for many years. One is the steaming and vacuum method, which is used mainly for southern yellow pine and to a less extent for other pines. The second is the boiling under vacuum or Boulton process, which is used mainly with Douglas fir and to a limited extent, for western hemlock, western larch, and some hardwoods. A third method, called vapor-drying, has recently come into limited use, mainly for southern pine poles and hardwood ties (24: 39).

### C. Pressure Processes

The most effective method of treating wood with preservatives is by means of pressure. There are a number of pressure processes, all of which employ the same general principle, but differ in the details of application. The timber to be treated is loaded on tramcars, which are run into a large steel cylinder. After the cylinder door is closed and bolted, preservative is admitted and pressure applied until the required absorption has been obtained. Two principal types of pressure treatment, the full-cell (Bethell), and empty-cell (Lowry and Rueping) are in common use (22: 1).

### 1. Full Cell Process.

In making treatments with the so-called "full-cell" or Bethell process, a preliminary vacuum is first applied to remove as much air as practicable from the wood cells. The preservative is then admitted into the treating cylinder without admitting air. After the cylinder is filled with preservative, pressure is applied until the required absorption is obtained (22: 2).

### 2. Empty Cell Process

Two empty cell treatments, the Lowry and the Rueping, are commonly used, both of which depend upon compressed air in the wood to force part of the absorbed preservative out of the cell cavities after preservative pressure has been released (24: 2).

The Rueping process uses compressed air which is admitted to the cylinder and held there until the fabric of the wood is thoroughly penetrated. Creosote is then admitted under a slightly higher pressure, the air in the cylinder gradually escaping. Finally, the pressure is released when the air which was first introduced within the wood expands and drives out much of the excess creosote.

The Lowry process differs from the Rueping process in that compressed air is not employed. The Lowry process also aims to secure a deep penetration of creosote with less oil than is required by the full-cell process. The Lowry process is extensively used throughout the United States.

## D. Nonpressure Process

Nonpressure methods consist of:

1. Superficial applications of preservative oils by spraying, brushing, or brief dipping.
2. Soaking in preservative oils or steeping in water solutions.
3. Diffusion processes with water borne preservatives.
4. Various adaptations of the hot and cold bath process (22: 421).

## BIBLIOGRAPHY

1. Brauner, A. and E. M. Conway. 1964. Steaming Walnut for Color. For. Prod. J. 14: 525-7
2. Brown, Harry P., A. J. Panshin and C. C. Forsaith. Textbook of Wood Technology, Vol. I. New York: McGraw-Hill 1964-Second Edition.
3. Brown, Harry P., A. J. Panshin and C. C. Forsaith. Textbook of Wood Technology, Vol. II. New York: McGraw-Hill, 1964.
4. Constantine, Albert. Know Your Woods. Home Craftsman, New York: 1966.
5. Feirer, John L. Cabinetmaking and Millwork. Peoria: Chas. Bennett Company, 1967.
6. Feirer, John L. Wood Working for Industry. Peoria: Chas. Bennett Company, 1964.
7. "Fine Hardwoods Make Fine Furniture" (Pamphlet) Fine Hardwoods Assoc. Chicago.
8. Gray, V. R. 1961. The Colour of Wood and Its Chances. J. Inst. Wood Sci. 8: 35-37.
9. Gronema, Chris H., and Everett R. Glazener. Technical Woodworking. St. Louis: McGraw-Hill, 1966.
10. Hammond, Donnelly, Harrod, and Norman A. Rayner. Woodworking Technology. Bloomington: McKnight and McKnight, 1961.
11. Jane, F. W. The Structure of Wood. A. and C. Black, London, 1956.
12. Kribs, D. A. 1950 "Commercial Foreign Woods on American Market". Edward Bros., Inc. Ann Arbor, Mich.
13. Latham, B. 1964. "Wood - From Forest to Man". Harrap and Co., Ltd., London.
14. Loos, W. E. and W. A. Coppoch. 1964. "Measuring Wood Color With Precision". For. Prod. J. 14:85-86
15. Record, S. J. 1934. "Identification of the Timbers of Temperate North America". J. Wiley and Sons, New York.
16. Stamm, A. J. 1964. "Wood and Cellulose Science". The Ronald Press Co., New York.
17. Tsoumis, George, Wood As Raw Material. Oxford: Pergamon Press 1968.

18. U. S. D. A. "American Wood". Leaflet Series, Forest Service. Washington, 1960.
19. U. S. D. A. "Fungi Associated With Principal Decays in Wood Products in the United States". Forest Service Research Paper Wo-4.
20. U. S. D. A. "Identification of Oak Woods", Technical note FPL-036. Forest Products Lab., Madison, Wisc.
21. U. S. D. A. "Present Status of Results-Type Specifications for Treated Wood". Forest Service Lab., No. 2260. Washington, 1962.
22. U. S. D. A. "Preservative Treatment of Wood". Forest Service, Ag. Handbook No. 40. Washington, 1952.
23. U. S. D. A. "Treating Wood By the Cold-Soaking Method". Forest Service Lab. No. 1445, Washington, 1963.
24. U. S. D. A. Wood Handbook. Forest Products Lab. Ag. Handbook No. 72, 1955.
25. Wangaard, F. F. "The Mechanical Properties of Wood", J. Wiley and Sons. New York: 1950.
26. Western Pine Association. What Causes Decay in Wood? Research Note No. 2.2211. Portland, Oregon, 1957.
27. Wilfong, J. G. 1966. Specific Gravity of Wood Substances. For. Prod. J. 16(1): 55-61.

**GLOSSARY OF TERMS**

for

**WOOD IDENTIFICATION AND CHEMISTRY**

**ANNUAL GROWTH RING**--The growth layer put on in a single growth year, including springwood and summerwood.

**BARK**--Outer layer of a tree, comprising the inner bark, or thin, inner living part (phloem), and the outer bark, or corky layer, composed of dry, dead tissue.

**BISERIATE RAY**--Ray consisting of two rows of cells, as viewed in the tangential section.

**CAMBIUM**--The one-cell-thick layer of tissue between the bark and wood that repeatedly subdivides to form new wood and bark cells.

**CELL**--A general term for the minute units of wood structure, including wood fibers, vessel segments, and other elements of diverse structure and function.

**CELL WALL**--The wall that encloses the cell contents; in a mature cell it consists of several layers.

**CELLULOSE**--The carbohydrate that is the principal constituent of wood and forms the frame work of the wood cells.

**CRYSTALLITES**--Regions in the cell walls in which the cellulose is arranged in a highly ordered crystal lattice of parallel chains.

**DIFFUSE-POROUS WOOD**--Certain hardwoods in which the pores tend to be uniform in size and distribution throughout each annual ring or to decrease in size slightly and gradually toward the outer border of the ring.

**HARDWOODS**--Generally one of the botanical groups of trees that have broad leaves in contrast to the conifers or softwoods. The term has no reference to the actual hardness of the wood.



**HEARTWOOD**--The wood extending from the pith to the sapwood, the cells of which no longer participate in the life processes of the tree. Heartwood may be infiltrated with gums, resins, and other materials that usually make it darker and more decay resistant than sapwood.

**HEMICELLULOSE**--Group of carbohydrates found in the cell wall in more or less intimate association with cellulose.

**LIGNIN**--The second most abundant constituent of wood, located principally in the middle lamella, which is the thin cementing layer between the wood cells. The chemical structure of lignin has not been definitely determined.

**PARENCHYMA**--Short cells having simple pits and functioning primarily in the metabolism and storage of plant food materials. They remain alive longer than the tracheids, fibers, and vessel segments, sometimes for many years. Two kinds of parenchyma cells are recognized, those in vertical strands, known more specifically as wood parenchyma, and those in horizontal series in the rays, known as ray parenchyma.

**PIT**--A relatively unthickened portion of a cell wall where a thin membrane may permit liquids to pass from one cell to another. A "bordered" pit has an overhanging rim that is not present in a "simple" pit.

**PITCH POCKET**--An opening extending parallel to the annual growth rings containing, or that has contained, pitch, either solid or liquid.

**PITH**--The small, soft core occurring in the structural center of a tree trunk, branch, twig, or log.

**POROUS WOODS**--Another name for hardwoods, which frequently have vessels or pores large enough to be seen readily without magnification.

**RADIAL**--Coincident with a radius from the axis of the tree or log to the circumference. A radial section is a lengthwise section in a plane that passes through the centerline of the tree trunk.

**RATE OF GROWTH**--The rate at which a tree has laid on wood, measured radially in the trunk or in lumber cut from the trunk. The unit of measure in use is number of annual growth rings per inch.

**RAYS OR MEDULLARY RAYS, WOOD**--Strips of cells extending radially within a tree and varying in height from a few cells in some species to 4 or more inches in oak. The rays serve primarily to store food and transport in horizontally in the tree. Wood rays that originate at the pith.

**RESIN PASSAGE (OR DUCT)**--Intercellular passages that contain and transmit resinous materials. On a cut surface, they are usually inconspicuous. They may extend vertically parallel to the axis of the tree or at right angles to the axis and parallel to the rays.

**RING-POROUS WOODS**--A group of hardwoods in which the pores are comparatively large at the beginning of each annual ring and decrease in size more or less abruptly toward the outer portion of the ring, thus forming a distinct inner zone of pores, known as the springwood, and an outer zone with smaller pores, known as the summerwood.

**SAP**--All the fluids in a tree, special secretions and excretions, such as oleoresin, excepted.

**SAPWOOD**--The living wood of pale color near the outside of the log. Under most conditions the sapwood is more susceptible to decay than heartwood.

**SOFTWOODS**--Generally, one of the botanical groups of trees that in most cases have needlelike or scalelike leaves; the conifers; also the wood produced by such trees. The term has no reference to the actual hardness of the wood.

**SPECIFIC GRAVITY OF WOOD (S.G.)**--The decimal ratio of the oven dry weight of a piece of wood to the weight of the water displaced by the wood at a given moisture content.

**SPRINGWOOD**--The portion of the annual growth ring that is formed during the early part of the season's growth. It is usually less dense and weaker mechanically than summerwood.

**STORIED RAYS**--Rays arranged in tiers or in echelons, as viewed on a tangential surface.

**SUMMERWOOD**--The portion of the annual growth ring that is formed after the springwood formation has ceased. It is usually denser and stronger mechanically than springwood.

**TANGENTIAL**--Strictly, coincident with a tangent at the circumference of a tree or log, or parallel to such a tangent. In practice, however, it often means roughly coincident with a growth ring. A tangential section is a longitudinal section through a tree or limb perpendicular to a radius. Flatgrained lumber is sawed tangentially.

**TRACHEID**--The elongated cells that constitute the greater part of the structure of the softwoods (frequently referred to as fibers). Also present in some hardwoods.

**TRANSVERSE**--Directions in wood at right angles to the wood fibers. Includes a radial and tangential directions. A transverse section is a section through a tree or timber at right angles to the pith.

**TYLOSES**--Masses of parenchyma cells appearing somewhat like froth in the pores of some hardwoods, notably the white oak and black locust. Tyloses are formed by the extension of the cell wall of the living cells surrounding vessels of hardwood or sometimes in a similar manner by the extension of the cell wall into resin-passage cavities in the case of softwoods.

**UNISERIATE RAY**--Ray consisting of one row of cells, as viewed in the tangential section.

**VESSELS**--Wood cells of comparatively large diameter that have open ends and are set one above the other so as to form continuous tubes. The openings of the vessels on the surface of a piece of wood are usually referred to as pores. They occur only in hardwood.

**WOOD FIBERS**--Thick-walled, tapering cells surrounding the vessels, and constituting the greater part of the wood tissue of the broadleaf trees. Wood fibers give strength and density to the wood tissue.

**XYLEM**--The portion of the tree trunk, branches, and roots that lies between the pith and the cambium.

### CELL STRUCTURE OF A SOFTWOOD

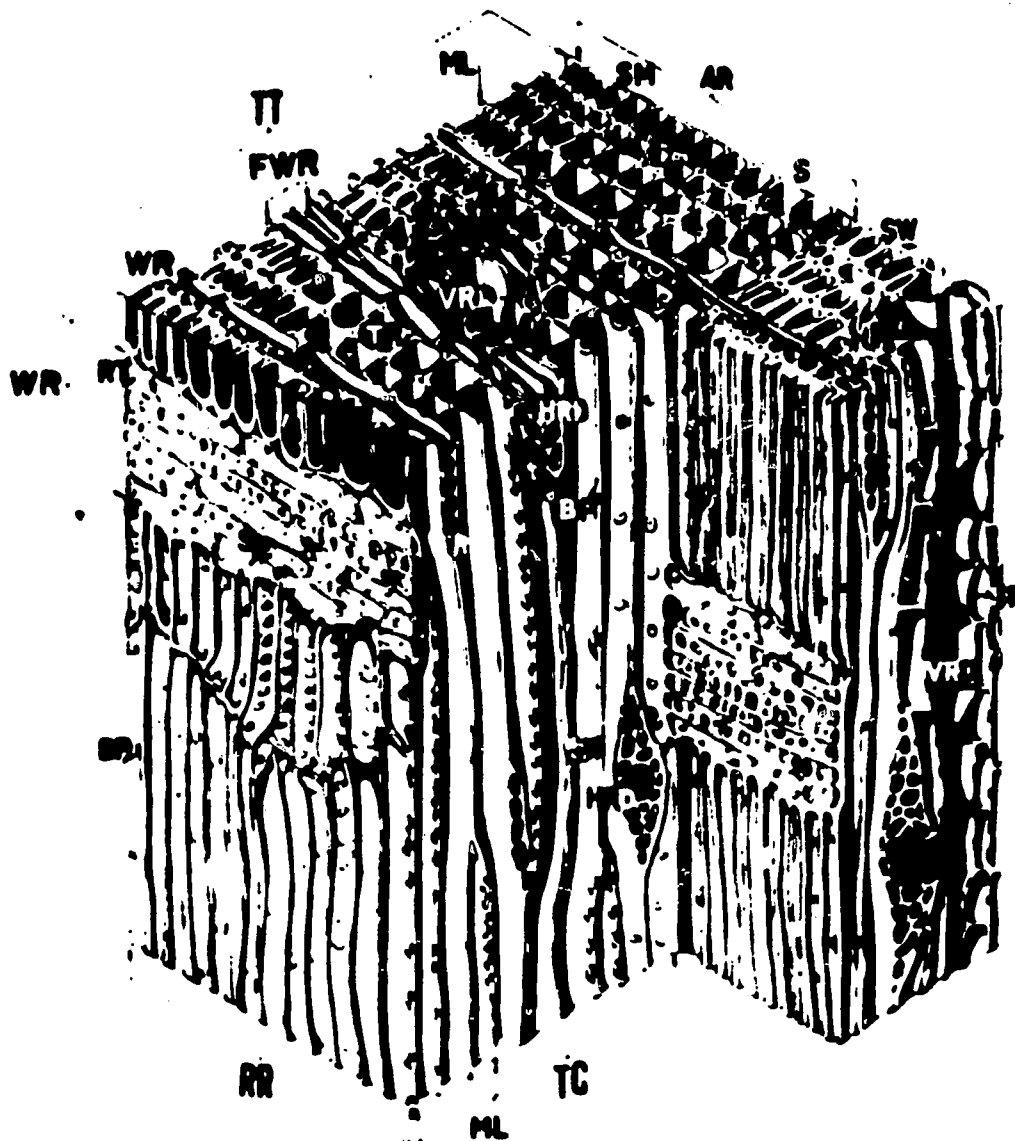

- AR - Annual Ring made up of early wood and late wood cells.
- BP - Bordered Pits have their margins overhung by surrounding cell walls.
- FWR - Fusiform Wood Rays are rays having horizontal resin ducts.
- HRD - Horizontal Resin Ducts found on end surfaces as fine white lines.
- ML - Middle Lamella is the cementing layer between all units.
- RR - Represents a verticle plane along the radius of the trunk.
- S - Springwood cells are the larger early wood cells.
- SM - Summerwood cells formed later in the growing period.
- SP - Simple Pit is the unthickened portion of the cell wall.
- TG - Surface at right angles to the radial or quarter-sawed surface.
- VRD - Verticle Resin Duct.
- WR - Wood Rays store and distribute horizontally the food material of the tree.

U.S. Forest Service Research Note.

### CELL STRUCTURE OF A HARDWOOD

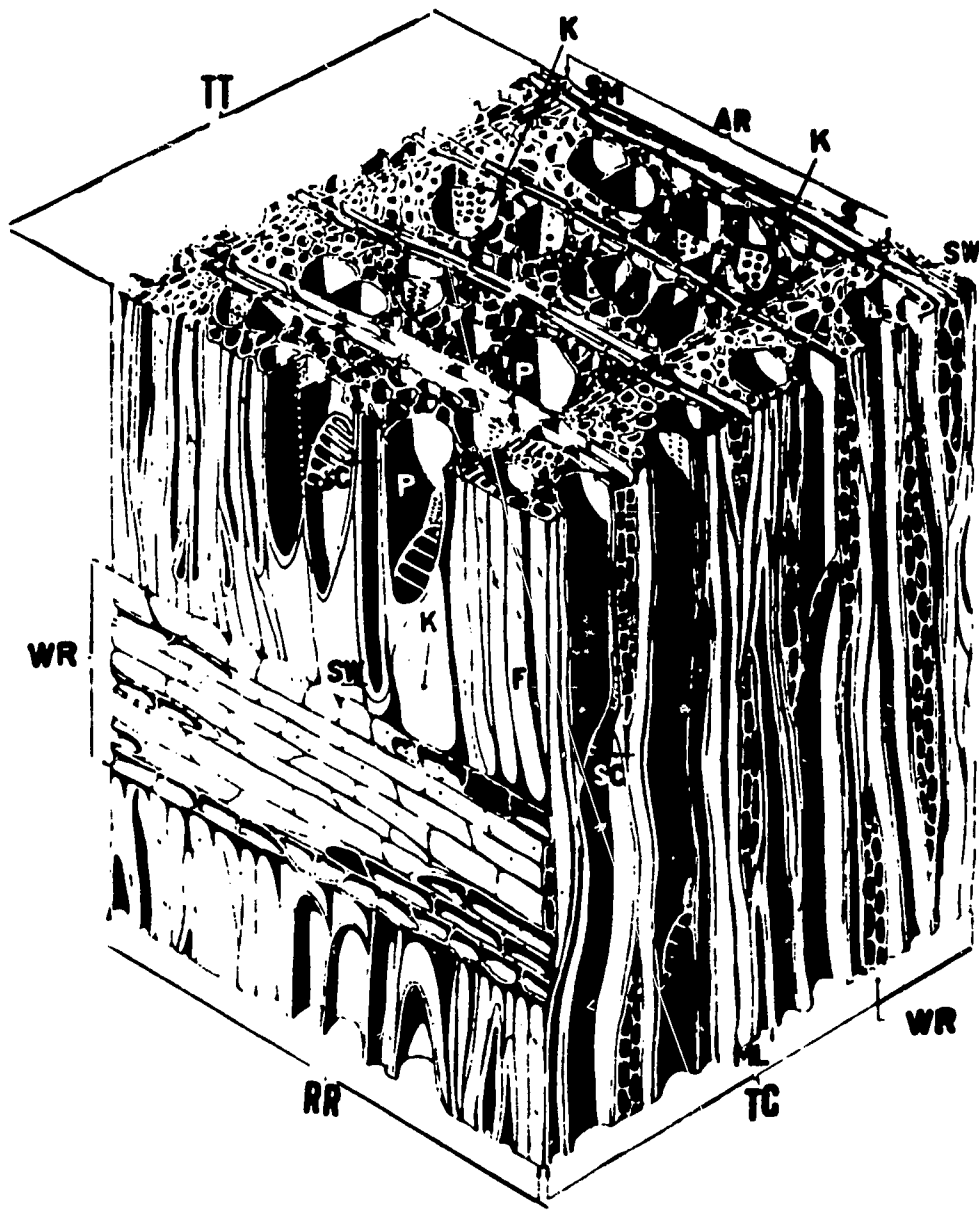

- AR - Annual Ring usually sharply defines one years growth from another.
- F - Wood Fibers are strength giving elements of hardwoods.
- K - Pits afford means for the passage of sap from one cavity to another.
- ML - Middle Lamella cements all wood cells together.
- P - Pores or Vessels for conducting sap.
- RR - A verticle plane of a surface cut parallel to the radius.
- S - Spring wood or early wood.
- SC - Grating separating the ends of the individual cells in some hardwoods.
- SM - Summer wood or late wood.
- TT - Horizontal plane corresponding to a minute portion of the top surface of a stump or end surface of a log.
- WR - Wood rays are strips of short horizontal cells that extend in a radial direction which store food and distribute it horizontally.

U.S. Forest Service Research Note.

### WOOD IDENTIFICATION

Problem: Name the parts of the tree trunk  
Write the correct answer following the letter that corresponds  
to each particular part.

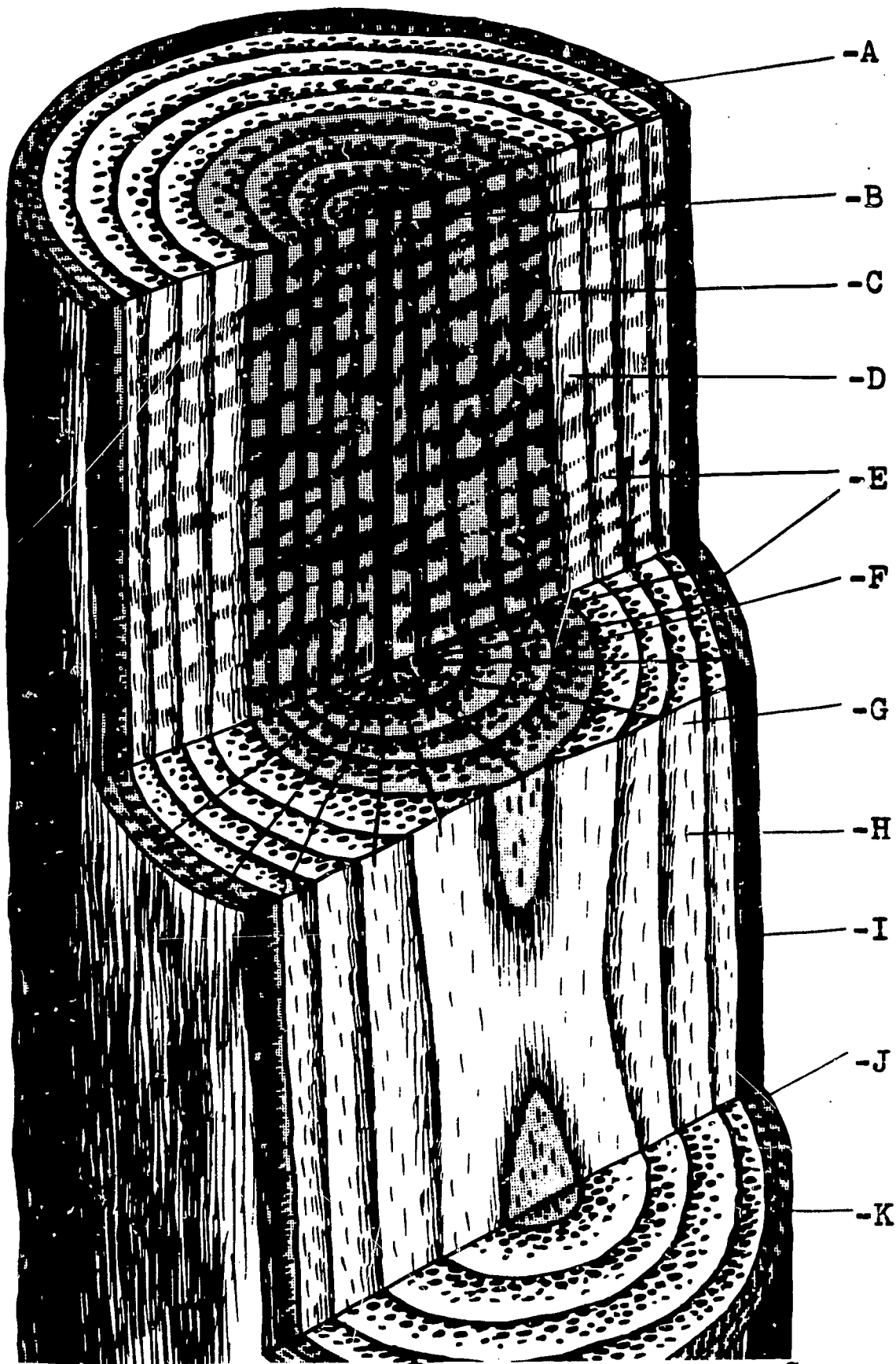

- |          |          |          |
|----------|----------|----------|
| A. _____ | B. _____ | C. _____ |
| D. _____ | E. _____ | F. _____ |
| G. _____ | H. _____ | I. _____ |
| J. _____ | K. _____ |          |

STUDENT LAB EXPERIENCE IN WOOD IDENTIFICATION

Purpose: To enable students to identify the various types of common softwoods and hardwoods.

1. After identification the student should study the characteristics of this particular wood.
  - a. To determine if the qualities it possesses lend themselves to his goals.
  - b. To determine if it is esthetically correct.
  - c. To determine if the price is right.

Procedure:

1. Student should select samples of the various woods available.
2. Student should determine whether it is a softwood or hardwood.
  - a. Use various charts, pictures, diagrams, and other teaching aids which are available.
    - (1). If student displays a desire to study wood identification in depth, demonstrate microscopic examination using Ripon Microslides.
3. After determining whether wood is a hardwood or softwood, the exact type shall be determined through the use of the media which is available.
4. Teacher will verify student identification.
  - a. If student makes wrong decision, teacher shall retrace student's steps and help in final correct identification.
5. Student shall keep accurate notes on each specimen identified.



## LAB EXPERIENCE

### Wood Identification Through the Use of Microslides and a Microscope

#### I. Procedure

##### A. Obtain necessary materials and equipment.

1. Microscope
2. Key to wood identification
3. Microslides

a. Use the following microslides:  
(Ripon)

W-S9	Bald Cypress
W-55	Douglas Fir
W-48	Ponderosa Pine
W-31	Sitka Spruce
W-40	Short-leaved Pine
W-43	Sugar Pine
W-57	Redwood
W-63	Western Red Cedar
W-420	Basswood
W-92	Birch
W-212	Black Walnut
W-332	Cherry
W-76	Sugar or Hard Maple
W-75	Silver or Soft Maple
W-360	Red Oak
W-350	White Oak
W-232	Yellow Poplar

b. Only the slide number is to be visible.

##### B. Using the key the student will separate the slides into two groups.

1. Soft woods
2. Hard woods

##### C. Using the key the student will identify the various kinds of soft woods and hard woods.

##### D. The student will keep accurate notes on his identifications.

##### E. The student will bring results to the teacher for verification.

1. If student has made an error, the teacher will retrace steps in identification to discover where student went wrong.
- F. Verified results shall become part of student note book.

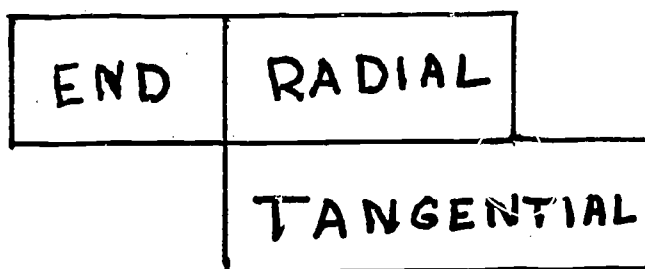

## CHARACTERISTICS OF MANY COMMON WOODS

Species	Comparative weights <sup>1</sup>	Color <sup>2</sup>	Hand-tool working	Nail-ability <sup>3</sup>	Relative density	General strength <sup>4</sup>	Resistance to decay <sup>5</sup>	Wood finishing <sup>6</sup>	Cost <sup>7</sup>
<b>Hardwoods<sup>8</sup></b>									
Apitong	Heavy	Reddish brown	Hard	Poor	Medium	Good	High	Poor	Medium high
Ash. brown	Medium	Light brown	Medium	Medium	Hard	Medium	Low	Medium	Medium
Ash. tough white	Heavy	Off-white	Hard	Poor	Hard	Good	Low	Medium	Medium
Ash. soft white	Medium	Off-white	Medium	Medium	Medium	Low	Low	Medium	Medium low
Avodire	Medium	Golden blond	Medium	Medium	Medium	Low	Low	Medium	High
Balsawood	Light	Cream white	Easy	Good	Soft	Low	Low	Poor	Medium
Basswood	Light	Cream white	Easy	Good	Soft	Low	Low	Medium	Medium
Beech	Heavy	Light brown	Hard	Poor	Hard	Good	Low	Easy	Medium
Birch	Heavy	Light brown	Hard	Poor	Hard	Good	Low	Easy	High
Butternut	Light	Light brown	Easy	Good	Soft	Low	Medium	Medium	Medium
Cherry. black	Medium	Medium reddish brown	Hard	Poor	Hard	Good	Medium	Easy	High
Chestnut	Light	Light brown	Medium	Medium	Medium	Medium	High	Poor	Medium
Cottonwood	Light	Grayish white	Medium	Good	Soft	Low	Low	Poor	Low
Elm. soft. northern	Medium	Cream tan	Hard	Good	Medium	Medium	Medium	Medium	Medium low
Gum. red	Medium	Reddish brown	Medium	Medium	Medium	Medium	Medium	Medium	Medium high
Hickory. true	Heavy	Reddish tan	Hard	Poor	Hard	Good	Low	Medium	Low
Holly	Medium	White to gray	Medium	Medium	Hard	Medium	Low	Easy	Medium
Limba	Medium	Pale golden	Medium	Good	Medium	Medium	Low	Medium	High
Magnolia	Medium	Yellowish brown	Medium	Medium	Medium	Medium	Low	Easy	Medium
Mahogany. Honduras	Medium	Golden brown	Easy	Good	Medium	Medium	High	Medium	High
Mahogany. Philippine	Medium	Medium red	Easy	Good	Medium	Medium	High	Medium	Medium high
Maple. hard	Heavy	Reddish cream	Hard	Poor	Hard	Good	Low	Easy	Medium high
Maple. soft	Medium	Reddish brown	Hard	Poor	Hard	Good	Low	Easy	Medium low
Oak. red (average)	Heavy	Flesh brown	Hard	Medium	Hard	Good	Low	Medium	Medium
Oak. white (average)	Heavy	Grayish brown	Hard	Medium	Hard	Good	High	Medium	Medium high
Poplar. yellow	Medium	Light to dark yellow	Easy	Good	Soft	Low	Low	Easy	Medium
Primavera	Medium	Straw tan	Medium	Medium	Medium	Medium	Medium	Medium	High
Sycamore	Medium	Flesh brown	Hard	Good	Medium	Medium	Low	Easy	Medium low
Walnut. black	Heavy	Dark brown	Medium	Medium	Hard	Good	High	Medium	High
Willow. black	Light	Medium brown	Easy	Good	Soft	Low	Low	Medium	Medium low
<b>Softwoods<sup>9</sup></b>									
Cedar. Tennessee red	Medium	Red	Medium	Poor	Medium	Medium	High	Easy	Medium
Cypress	Medium	Yellow to reddish brown	Medium	Good	Soft	Medium	High	Poor	Medium high
Fir. Douglas	Medium	Orange-brown	Medium	Poor	Soft	Medium	Medium	Poor	Medium
Fir. white	Light	Nearly white	Medium	Poor	Soft	Low	Low	Poor	Low
Pine. yellow longleaf	Medium	Orange to reddish brown	Hard	Poor	Medium	Good	Medium	Medium	Medium
Pine. eastern white ( <i>Pinus strobus</i> )	Light	Cream to reddish brown	Easy	Good	Soft	Low	Medium	Medium	Medium high
Pine. ponderosa	Light	Orange to reddish brown	Easy	Good	Soft	Low	Low	Medium	Medium
Pine. sugar	Light	Creamy brown	Easy	Good	Soft	Low	Medium	Poor	Medium high
Redwood	Light	Deep reddish brown	Easy	Good	Soft	Medium	High	Poor	Medium
Spruces (average)	Light	Nearly white	Medium	Medium	Soft	Low	Low	Medium	Medium

<sup>1</sup> Kiln dried weight.<sup>2</sup> Heartwood. Sap is whitish.<sup>3</sup> Comparative splitting tendencies.<sup>4</sup> Combined bending and compressive strength.<sup>5</sup> No wood will decay unless exposed to moisture. Resistance to decay estimate refers only to heartwood.<sup>6</sup> Ease of finishing with clear finishes.<sup>7</sup> Prices for best grade.<sup>8</sup> Leaf bearing tree.<sup>9</sup> Cone and needle bearing trees.

8

IDENTIFICATION CODE SHEET

HARDWOODS

A. Ring Porous

1. Hickory
2. Black Walnut
3. Ash
4. White Oak
5. Red Oak
6. Teak

B. Diffuse Porous

1. Red Gum (Sweet Gum)
2. Cottonwood
3. Limba (Korina)
4. Cherry
5. Afromosa
6. Hard Maple
7. Soft Maple
8. African Mahogany
9. Birch

SOFTWOODS

A. Resinous

1. Douglas Fir
2. Southern Yellow Pine
3. White Pine
4. Sugar Pine
5. Ponderosa Pine (Western Yellow)

B. Non-Resinous

1. Eastern Red Cedar
2. Redwood

A cross-section detail of a log listing the easily recognized parts as distinguished from the minute anatomy of wood.

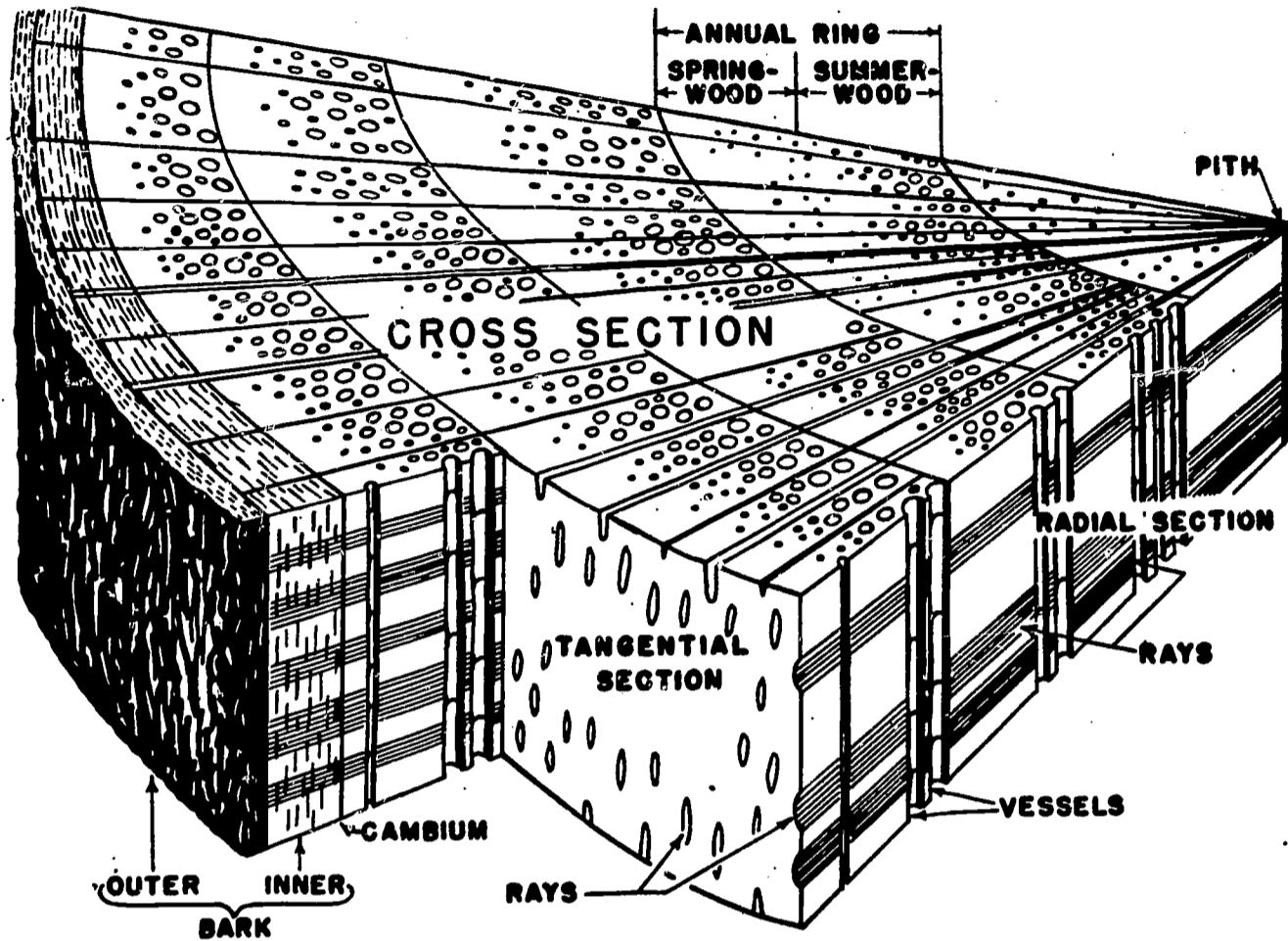

Wood is usually identified from three different planes of a section of wood. The face that is exposed when wood is cut or sawed at right angles to the grain is the transverse surface or cross section. The end grain is visible in this plane and is the surface most often used in wood identification. The radial and tangential surfaces sections are at right angles to the transverse surface. A truly radial section would pass from the bark through the pith of the tree, following a radius of a cross section of the log. The tangential face of wood is exposed when the bark is peeled from a tree.

San Diego State College  
NDEA Woodworking Technology

SEASONING

A Teaching Unit

by

Neal D. Gadwah  
Robert J. Moore  
William A. Long  
Harry C. Seifert

Submitted in partial fulfillment  
of the requirements  
for the course of

Industrial Arts 298

August 2, 1968

## TABLE OF CONTENTS

	PAGE
INTRODUCTION . . . . .	1
CHAPTER	
I. PROPERTIES OF WOOD RELATED TO DRYING . . . . .	2
II. AIR-DRIED LUMBER . . . . .	5
Surface . . . . .	6
Foundation . . . . .	6
Stacking . . . . .	6
Stacking Operation . . . . .	7
Shelter . . . . .	7
Figure I . . . . .	8
III. KILNS AND KILN DRYING . . . . .	10
History of Kiln Drying . . . . .	10
Why Wood Must Be Kiln Dried . . . . .	10
Kiln Types and Features . . . . .	11
Progressive Kiln . . . . .	11
Compartment Kiln . . . . .	12
Kiln Construction . . . . .	12
The Drying Process . . . . .	13
Kiln Operation . . . . .	14
IV. SPECIAL METHODS OF SEASONING WOOD . . . . .	16
High Temperature Drying . . . . .	16
Infrared Radiation . . . . .	16
Vacuum Drying of Wood . . . . .	17
Solvent Seasoning and Presteamng	
Seasoning Methods . . . . .	18

## TABLE OF CONTENTS (cont.)

CHAPTER	PAGE
Boiling in Oily Liquids . . . . .	18
High Frequency Dielectric Heating . . . . .	19
Salt Seasoning . . . . .	20
Polyethylene Glycol 1000 . . . . .	20
Table I . . . . .	23
V. SEASONING DEFECTS . . . . .	24
Shrinkage . . . . .	24
Warping . . . . .	25
Casehardening . . . . .	26
Checks . . . . .	27
Collapse . . . . .	28
Knots . . . . .	28
Fungus . . . . .	29
RECOMMENDATIONS . . . . .	30
SUGGESTED STUDENT LAB EXPERIENCES . . . . .	31
HAND OUT SECTION and SUGGESTED TEACHING AIDS . . . . .	33
GLOSSARY . . . . .	41
SELECTED BIBLIOGRAPHY . . . . .	45



## INTRODUCTION

The authors of this report have extended efforts at summarizing four areas under the report title "Seasoning". The words seasoning and drying will appear frequently throughout this report. To many people perhaps, seasoning means something more than drying; the majority may reply that some form of maturing process is implied as well as drying. Scientific investigations have portrayed that for all practical purposes there is no difference between a single piece of wood seasoned over a period of years and another piece dried for as short a duration of time as a few days. By means of chemical analysis slight differences can be detected, but their effects on the mechanical and physical properties of timber can be neglected due to their insignificance (1:1).

For the purpose of this report, therefore, the words "drying" and "seasoning" can be regarded as synonymous and are used as such.

## CHAPTER I

### PROPERTIES OF WOOD RELATED TO DRYING

Green timber, timber in the growing tree or in the tree immediately after it is felled, contains considerable quantities of water, commonly called sap. Although sap contains some materials in solution, we need only concern ourselves here with the water. The moisture is present in green timber in two forms: It fills or partially fills the cell cavities (free water), and it is present in the cell walls (bound water). A green beech log six feet long and eighteen inches in diameter may contain as much as 36 gallons of moisture (1:3).

The amount of moisture contained within a given piece of wood is spoken of as its moisture content (MC), and is expressed as a percentage of the oven-dried weight of the wood. The oven-dried weight will be spoken of more in detail later on in this report. Moisture content may vary within the same species and as much as 30 to 300 percent among different species (24:311).

Wood begins to dry on its outer surfaces, those exposed to the air, and dries toward the interior. In drying, the surface fibers of the heartwood of most species attain moisture equilibrium with the surrounding atmosphere almost as soon as drying begins, and at this time a moisture gradient begins to develop (4:10). If the air circulates fast enough to evaporate the water as it moves to the surface of the wood, the surface fibers of sapwood also will tend to reach a balanced state in respect to the surrounding drying atmosphere very early in the drying process. A much longer time is required for the surfaces of sapwood to attain equilibrium however, if air circulates too slowly.

Moisture moves, as a liquid or a vapor through several kinds of passageways which make up the internal structure of wood; cavities of fiber and vessels, wood ray cells, pit chambers and their pit membrane openings, resin ducts of certain softwoods, other intercellular spaces, and transitory cell-wall passageways (4:11). Most of the moisture lost by the wood, however, moves through its cell cavities and its small openings in the cell walls. Moisture will move longitudinally as well as laterally with the lighter woods generally drying more rapidly than the heavier woods.

When green wood begins to dry capillary action takes place. Water is evaporated from the surface of the board which exerts a pull on the free water under the surface which in turn causes water to flow. Moisture is also made to flow by another force known as diffusion; differences in relative humidity and moisture content between the surface and the interior, and simultaneous diffusion of water vapor and bound water. Diffusion is a slow process when compared to capillary action ( 4:11-12).

Most of the moisture is removed from the wood during the drying process by lateral diffusion; depending to a large extent on the thickness of the cell walls and their permeability and also on specific gravity where the rate of diffusion decreases as specific gravity increases. Therefore, the more permeable woods dry faster than the less permeable ones ( 4:12).

The tree's sapwood usually dries faster than its heartwood both by diffusion and by capillary action when drying conditions are the same; believed to be due to the fact that extractives plug the small cell wall openings of the heartwood ( 4:12). When the heartwood loses its moisture faster than the sapwood, as in some species, the initial amount of moisture contained in the heartwood is much lower than that of the sapwood.

As wood dries, the moisture first leaves the cell cavities. When the cavities are emptied the water is then contained within the cell walls themselves. This point in the drying process is called the "Fiber Saturation Point". The moisture content at this point is approximately 30 percent for all woods.

As wood continues to dry the moisture contained within itself will tend to balance itself out with that in the atmosphere which surrounds it. The moisture content at this point is called the equilibrium moisture content (EMC). The equilibrium moisture content that timber will attain under any given circumstances is influenced by its previous state. If it contained more moisture before, it will reach equilibrium at a higher moisture content than it would if it was dryer and had to absorb moisture. This hysteresis effect, to be explained more fully, affects the shrinkage and swelling of lumber and is dealt with considerably in the seasoning of lumber.

The determination of moisture content is largely held to two methods. The most expedient and conventional method is the electrical method whereas probably the most exacting but slower method is the oven-dried method. See worksheet on

oven-dried method.

In determining a wood's moisture content via the electrical meter method, a careful selection of a reliable meter to purchase is of primary importance. The electrical properties of wood such as electrical resistance, dielectric constant, and power loss factor are made use of when using the moisture meter (24:320). To obtain accurate readings, manufacture's specifications as to use and maintenance should be carefully adhered to.

Listed below are several reasons why lumber and other wood products must be dried. These reasons would be dependent on the species and the use to which it is put.

1. It must be dried so that shrinkage and change in shape will be at a minimum after it is fashioned into shape.
2. Green wood is heavy and drying will minimize the cost of shipping. Also the space required will be lessened for the same volume of wood.
3. Certain kinds of stain and mold will attack green lumber if it is not properly handled immediately after cutting; for example blue stain on pine.
4. Lumber must be dried to meet customer demand.
5. Saw milling is generally carried on at certain seasons whereas lumber markets are likely to demand lumber throughout the entire year. Therefore, lumber storage yards are used to store the lumber in order to keep the market regularly supplied.
6. Wood that is to be painted must be well seasoned to best prevent blistering and peeling.

## CHAPTER II

### AIR-DRIED LUMBER

A good definition of air seasoned lumber might be: "Lumber that has been properly yard piled through a whole active drying season and has reached a specified moisture percent" ( 8:1).

There are many factors that influence air drying such as temperature, percipation, humidity, season of the year, topography of the land, location, management of the yard, method of piling, species of wood, nearness to large bodies of water, and air circulation. These things must be taken into consideration when air drying lumber.

The principle of air drying is to have the moisture pass over the green lumber, absorb the moisture, and carry it away. Any air that is below 100% relative humidity possesses the ability to complete this function. The air passing over the pile is cooled by picking up moisture given off from the seasoning lumber. The drop in temperature causes an increase in the relative humidity in the air. The result of this condition causes the loss in ability for any further drying of the lumber. To compensate for this loss the air must be removed and a fresh supply brought in to reduce the drying cycle (15:2). This supply is accomplished by the natural horizontal and vertical air movement.

Vertical movement, which is generally downward, is caused by the increase in density of the air within the piles as it is cooled. Horizontal air movement within the piles is induced by this difference in pressure between the two sides of the pile caused by winds (15:2).

The moisture content which lumber in the air drying pile will assume depends upon the moisture content of the atmosphere. Wood will give off or take on moisture from the surrounding atmosphere until the amount of moisture in the wood balances that of the atmosphere. When this point is reached it is expressed as equilibrium moisture content. Moisture content varies from one section of the country to another depending upon the climatic conditions (24:311).

Lumber may be cut and piled any time of the year and it will start to cure immediately; but only from April to October is the temperature high enough and the humidity low enough to carry on rapid drying to a low moisture percent. The Forest

Products Laboratory recommends this percent be from 12% to 15% (24:325).

It is not possible to control the temperature, relative humidity, and air circulation, in air drying, the way these factors can be controlled in the kiln drying process ( 2:179).

#### SURFACE

It is of the utmost importance that the ground, where the lumber is to be stored, be kept free of any foreign objects such as weeds or scrap lumber debris. Vegetation has been proven to hold back the flow of proper circulation needed in the drying process and could cause blue staining and decay to the lumber.

Treatment to impede the growth of vegetation may be gravel, used oil, crushed rock, shells, or weed killers. It is recommended that the alleys where the fork lift truck travels be paved with black top to impede the weed growth and help reduce maintenance on the machinery (15:4).

#### FOUNDATION

Lumber that is air dried is put on foundations which hold the lumber off the ground. It is necessary that the foundation be of very strong material and also be able to resist organisms that attack wood. Some of the materials used in construction of foundations are heartwood beams, bricks, concrete, and steel I beams.

Foundations are recommended to be constructed so that they slope from front to back as this provides good drainage from rain or melting snow.

Today, most of the larger mills are making permanent roofed buildings with permanent foundations thus making it easier to remove the dried lumber with a fork lift tractor ( 2:180-1).

#### STACKING

It is recommended that lumber be stacked according to species, thickness, width, length, and grade. An example of this is "One inch red gum which needs rapid drying to prevent blue stain, unless dipped in an anti-stain solution, while one inch southern oak needs a more moderate drying condition as it is susceptible to checking" (15:8). In addition to like grade, species, and thickness the Forest Pro-

ducts Laboratory recommends that the lumber be sorted into piles of 1000 to 2000 board feet to aid in handling if the lumber is to be further dried in the kiln process.

It is desirable that the lumber stacks be square on the ends and arranged neatly so that one board does not affect the circulation of air to the rest of the pile. The stacks should be standard lengths so that combinations of shorter lengths can be used to complete the stack (15:8).

When very rapid air drying is required end piling, end racking, and crib piling are often resorted to in place of the more conventional flat piling. These methods permit more rapid drying than flat piling but have certain disadvantages. Warping, checking, and the requirement of more yard space are some of the disadvantages to these systems ( 2:186).

#### STACKING OPERATION

The majority of the cut lumber is hand stacked soon after it has been cut to size. Today with the increased use of a straddle or fork lift tractor modern lumber mills are now stacking the green lumber in piles directly from grading, or the sorting chain, and then transported to the storage site.

The stacking is usually done with the aid of a stacking jig. The lumber is laid out with small air spaces between the boards and after a layer is filled out and spaced properly, wood slats are positioned across the layer. These slats are called stickers or crossers. The stickers provide the proper space between layers of lumber so that air may circulate through the entire stack. It is important that the stickers be spaced evenly as this will help prevent drying defects (15:13-14).

#### SHELTER

Most lumber men construct a roof on their better grade lumber stacks in order to provide protection from the sun and precipitation, thus reducing degrade in the lumber during the drying period.

The roof is most commonly constructed from two layers of low grade lumber. The roof should extend at least two feet in front and in the rear of the pile with a pitch to send the run off water to the rear of the stack. See Figure I.

DRYING RATE OF PINE BOARDS  
IN DIFFERENT PARTS OF THE PILE

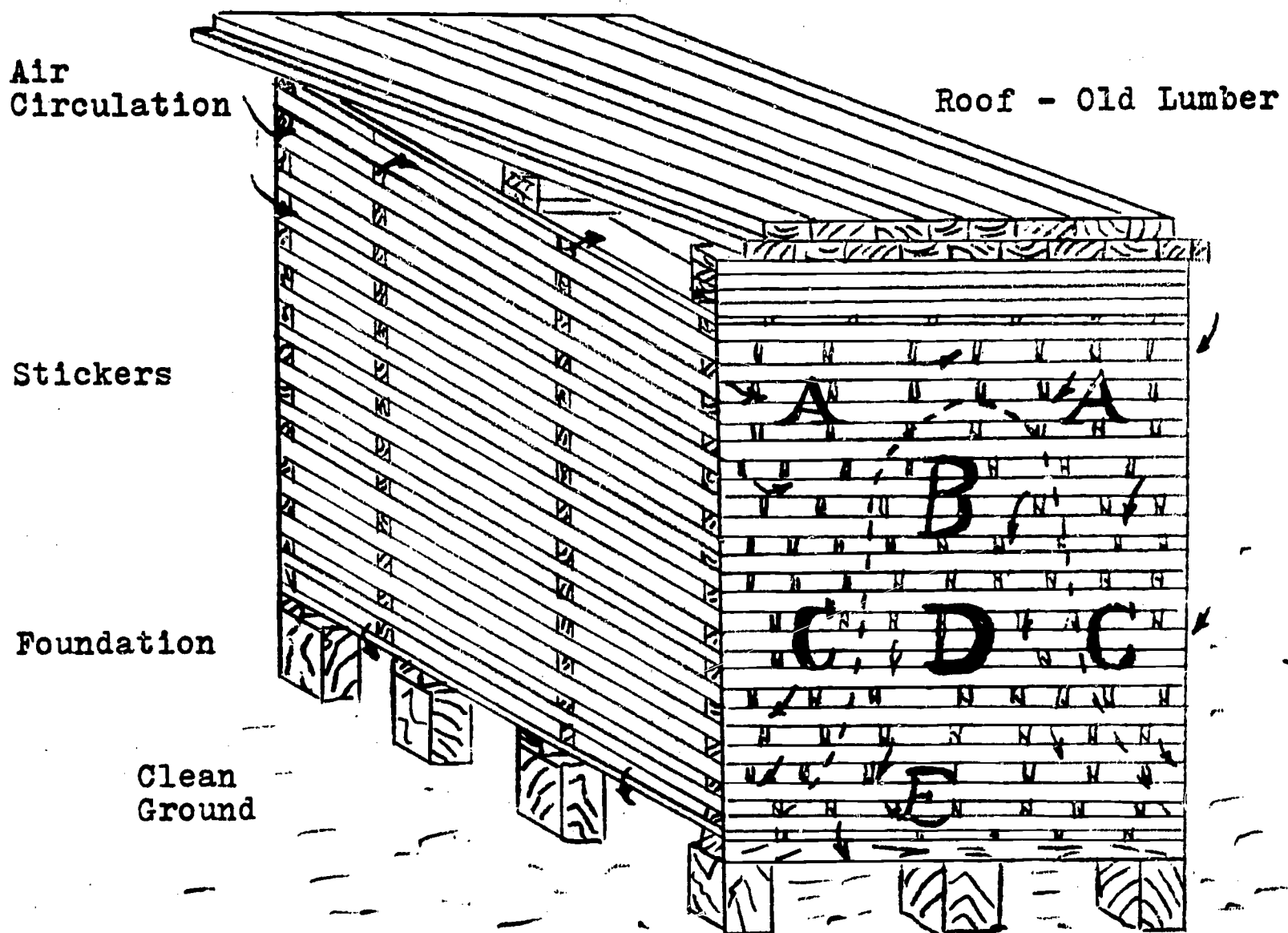

FIGURE I

The lumber is one inch boards piled in April with spacing of two inches between the boards. The pile is approximately 12 feet wide, 16 feet high with no central flue.

The time necessary to dry to:

	25% moisture	18% moisture
A.	2 weeks	2½ weeks
B.	3 weeks	4 weeks
C.	4 weeks	7 weeks
D.	8 weeks	12 weeks
E.	20 weeks	27 weeks



Many lumber mills are now constructing permanent shelters in which to store their lumber. Commercial roof products such as rolled roofing, shingies, and corrugated sheet metal are being used in the construction of these new storage shelters (15:15-18).

## CHAPTER III

### KILNS AND KILN DRYING

#### HISTORY OF KILN DRYING

Throughout history many uses for wood have been found by man. Time and experience has taught him that if wood was exposed to the elements of nature for a long period of time he could shape it with tools into useful products without fear of it changing shape or pulling apart. He also discovered, even though large pieces of lumber were exposed to outside drying for many years, they still lacked sufficient drying to prevent checking or shrinkage, thus spoiling his completed project.

Man had an idea to bring wood into his workshop early and let it get conditioned to the shop thus helping reduce splitting after carving it into shape.

The next step man did to conquer his development in the seasoning process was the placing of the wood in rooms through which the smoke from fire passed. While the wood was always air seasoned before the start of this process, the drying was speeded up greatly, but man had the problem of blackened lumber.

With the advent of steam and hot air furnaces principles were applied to the drying of lumber and lumber products. Consequently, lumber men began to develop the modern kiln principle. The development of drying lumber occurring soon after the Civil War employed the use of steam coils and chimneys enabling the escape of the moisture. The term kiln was applied to this process as they literally baked or killed the life of this wood (15:11).

#### WHY WOOD MUST BE KILN DRIED

Kiln drying accomplishes several useful purposes which are indispensable. Kiln drying green or wet lumber at the sawmill or lumber yard is practiced for one or more of the following reasons:

1. Quickly prepares the lumber for market.
2. Reduces its weight for shipping.
3. Prevents molds, stains, and insect attacks.
4. Saves the cost of long periods of drying in the open air.

5. Helps prevent splitting, surface checking, and warping which are prevalent in air-dried lumber.
6. Meets the consumer market demand.
7. Lowers the moisture content to a lower moisture percent than can be obtained by air drying.
8. Helps make gluing and varnishing successful.
9. Makes proper machining possible (15:112).

As in the air seasoning process, the kiln drying reduces the weight, prevents insects and fungi attacks, but its prime purpose is to condition or cure the stock so it will not shrink, swell, or warp after it has been constructed into the finished article (15:112).

#### KILN TYPES AND FEATURES

Lumber dry kilns are commonly classified on the basis of the charging methods. Kilns are classified as either progressive or compartment type kilns. The kilns contain one or more chambers in which the air can be circulated around the wood being dried. In the kiln drying process the temperature and humidity of this air can be controlled manually or automatically by the control of the wet-dry bulb temperature system ( 2:1).

Good kiln design is important to the operation and drying efficiency. A well designed kiln of either major type will dry the lumber to a moisture reading of 3 to 15 percent in a reasonably short time depending on the species and size of the lumber being dried ( 2:1).

#### PROGRESSIVE KILN

The progressive kiln can be compared to an electrical circuit, as it completes a given path. The kiln building is an enclosed structure with large doors at each end.

The green or wet lumber is stacked in packages and placed on a cart which in turn travels on a track system through the kiln. This cart is referred to as a truck. The truck of lumber enters the front door and works slowly to the rear or back door. Each time a load is removed from the kiln it is taken from the rear entrance and a green load is replaced in the front entrance, representing a progression with lumber to be dried proceeding a step closer to the finished end. The drying conditions of this type of kiln are less severe at the finish end. This is accomplished by having more heating coils at the front end where the higher dry bulb reading is desired ( 2:1).

One major draw back to this type of kiln is that you must have a constant supply of lumber entering the kiln to keep the progression moving or void spaces will develop in the kiln. Void spaces represent a loss to the operator as the whole building is being heated during this process. Another disadvantage is the inability to mix different charges of lumber containing different species of wood. An example would be that a load of pine could not be intermixed with oak as the drying schedule requirements are not the same for the two woods.

This system works best where the lumber mill is drying one major species of timber.

#### COMPARTMENT KILN

The compartment kiln is like a 4-5-6-7 stall garage in which the kiln may have single doors on the side or large doors at each end in which to load or unload the lumber.

This type of kiln is usually charged all at one time and the lumber is stationary until removed. Some of the compartment kilns do not use the track with trucks as used in the progressive kilns but have constructed foundations for the lumber to rest on. These kilns employ fork lift tractors to load and unload the lumber packages ( 2:1).

Some of the advantages of the compartment kiln are that the kiln operator may partially fill the kiln with lumber, and he may also mix the kiln with different species of lumber.

#### KILN CONSTRUCTION

A great many building materials have been tried for construction of kilns, but through continued research the most suitable materials have been found to be wood, concrete, concrete blocks, brick, and terra cotta tile. During the past few years the employment of sheet metal, especially in the construction of prefabricated kilns, has been extensive.

The prime requirements that must be considered in the construction of kilns are:

1. Physically strong enough to support the lumber load and heating-circulation equipment without mechanical failure.

2. Construction must be such that the kiln will not disintegrate through the action of deterioration, organism, or corrosion.

3. It must be well insulated to prevent heat loss as this factor will cause excessive operating costs.

4. It must be of fireproof construction (24:187).

5. The kiln should be protected with asphaltum paint to retard the constant corrosive action on the metal parts as well as the motor.

#### THE DRYING PROCESS

The three interlocking fundamental factors in drying are circulation of air, heat, and relative humidity. Each of these factors must be present in the proper proportion or an unbalance in the operation will develop ( 8:164).

Mr. O.W. Torgerson stated four major functions of circulation of air be considered in his booklet Circulation of Air in Lumber. They are:

1. To distribute heat uniformly throughout the kiln and maintain a uniform temperature.

2. To carry away the evaporated moisture from the board surface.

3. To provide a means of mixing and conditioning the air before it enters the load.

4. To carry heat away from the heating coils and thus increase the heat transmission rate (21:1-2).

Methods used to produce circulation of air are natural (action of gravity) and mechanical. Since the gravity system is slow it may be speeded up with the aid of fans. Fans not only speed up the drying process, but they also may be reversed to permit the uniformity in drying the reverse side of the load ( 2:208).

The second indispensable item we must consider is heat. The heat is generally supplied through steam or hot air systems. Generally, most kilns are equipped with the steam heating system.

The steam travels through coils of pipe either on the wall or near the underside of the roof with blowers to force air down, across, and through the lumber loads.

One prime factor is the necessity for the temperature not to vary over several degrees in a kiln. Booster coils are often placed between loads, especially in a double track compartment kiln, in order to reheat the cooled air that has passed through a load of drying lumber so that the air may keep a constant even temperature in the kiln ( 2:200).

The relative humidity controls the rate of evaporation of the air. Relative humidity is the amount of moisture in the air at any given time as compared to the quantity it is capable of holding when saturated at the same temperature.

Relative humidity is always given as a percent. An example of this is if air is to contain fifty percent relative humidity it has only one-half of the moisture it is capable of absorbing at that temperature.

Since hot air will hold more moisture than cold air we can regulate the rate of evaporation from lumber by simply controlling the relative humidity of the air surrounding the lumber.

The relative humidity can be controlled in two ways. The first is dry steam may be added to raise the relative humidity in the kiln. The second factor is, if air in the kiln becomes too moist it is replaced with the drier outside air ( 2:208).

#### KILN OPERATION

A kiln schedule is a carefully worked out set of dry-bulb and wet-bulb temperatures which the operator can use to season a specific wood at a satisfactory rate without causing objectionable drying defects. Schedules may be classified as general and special. General schedules cover the entire range of drying conditions normally used in dry kilns. Special schedules are those developed to attain certain drying objectives; for example, to reduce drying time, dry chemically treated wood, or maintain maximum strength for special uses.

Rapid drying is achieved in kilns by the use of high temperatures and low humidities. Improper drying conditions may lead to drying defects.

Hardwoods generally take a longer time, than softwoods. Many of their uses critically depend on drying defects and moisture content. Hence their schedule is based on moisture content.

Satisfactory time schedules have been worked out by industry for repeatedly drying softwood items of a very uniform character in the same type of kiln. The general schedules are conservative enough to produce stock with a

minimum of drying defects in a reasonably short time ( 5:117).

In order to maintain the correct readings samples are placed at given spots on the lumber load. These samples are checked at various intervals of time to assure proper drying conditions are maintained in the kiln.

## CHAPTER IV

### SPECIAL METHODS OF SEASONING WOOD

Research regarding the seasoning of lumber by methods other than the air and kiln drying processes is a continuous development. Following are some of the special methods of seasoning which have been developed or are presently being researched.

1. High Temperature Drying was used during World War I in the Pacific Northwest. Rapid drying rates were accomplished with some softwoods being dried to 10% moisture in 24 hours at drying temperatures as high as 230° F. in an atmosphere of steam. The relative humidity of the steam was regulated by controlling the dry-bulb temperature and maintaining a wet-bulb temperature at the boiling temperature of water (212° F.). This method is applicable to such soft woods as one-inch Douglas-fir, true firs, western hemlock, ponderosa pine, southern yellow pine, basswood, and sapwood of sweetgum. Research has shown this method to be desirable for seasoning hardwoods or for softwoods that have a tendency to collapse (10:1).

One of the major disadvantages of the severe drying conditions was the rapid deterioration of materials used in kiln construction. Because of this the use of super-heated-steam kilns was discontinued in the United States. Today these kilns are primarily manufactured in Germany.

2. Infrared Radiation has been found to be impractical in most instances for seasoning of wood. To apply infrared radiation to all surfaces of each board would require the single-file, board by board passage of the lumber through a tunnel on a traveling chain. This would be a highly impractical and costly method that would have to compete in output with commonly provided kiln capacities of 20,000 to 60,000 board feet that are standard in the process of drying lumber by heated air (11:4).

Relative humidity must be controlled within the desired limits at the surface of the wood. This is impossible when the surface of the wood is heated to a temperature greater than that of the surrounding air because the wood heats the adjacent air layer and thus lowers the relative humidity at the wood surface. This is the problem with the infrared rad-



iation method of seasoning.

Thin stock such as veneer must have pressure applied through the use of springs, rollers, mesh, or plates to prevent wrinkling and buckling during drying. In drying with infrared radiation the restraining mechanism would interfere with the application and distribution of heat.

Even though practical applications were found for the difficulties of using infrared radiation for the seasoning of wood, the cost of electricity would be greater in most localities than the cost of steam (11:1-2).

3. Vacuum Drying of Wood was developed by Charles Howard who was granted a patent for the vacuum process in 1893. Many other processes have been proposed for using a vacuum to season wood. But no vacuum process for drying lumber has come into use either here or abroad, except the steaming and vacuum process to treat poles and other pine timber prior to the preservative treatment. Positive results have been obtained using small experimental vacuum-drying equipment, but presently there are several reasons why this process is not practical at this time (23:1).

There is a large cost factor because of the expensive equipment required and also the woods which dry rapidly in a vacuum also dry fast in a kiln.

The use of a vacuum alone is not effective for rapidly drying wood. Drying of wood involves two processes, movement of water to the surface of the wood and removal of the water from the surface. A vacuum maintained by continuously withdrawing the vapors from the drying chamber materially aids removal of the water from the surface for a short time, but considerable heat is required to evaporate the water. The evaporation of water from wood in a vacuum quickly cools the wood so that the evaporation becomes very slow in spite of the vacuum. Furthermore, except at the very start, the rate of drying of wood is governed by the rate of moisture movement from the interior to the surface. A vacuum has very little effect on the rate of moisture diffusion through wood. The vacuum processes proposed for drying wood, therefore have incorporated some means of heating the wood before the vacuum is applied. Hot airs, hot water or other liquids, and steam have been used for heating (23:1-2).

4. Solvent Seasoning and Presteaming Seasoning Methods have been used experimentally in the redwood industry. Redwood requires the longest drying time of any commercial softwood species and thus represents a major problem in the manufacturing process. Millions of board feet of lumber are tied up in the air drying yards representing a large capital investment. Consequently, the redwood industry has done much experimenting with accelerating the drying of redwood.

One experimental method used is solvent seasoning using acetone as an extractant, proved in pilot test runs to be a rapid method of removing water and some extractives from redwood, thus minimizing stain in the dried materials and yielding the extractive as a chemical by-product (19:5).

The presteaming treatment was also used successfully to increase the drying rate of lumber in air and kiln drying. The reduction in drying time was explained partly by direct expulsion of water, rapid vaporization of moisture during the cooling period after steaming, and presumably an increase in the permeability of wood (19:5).

5. Boiling in Oily Liquids can be used to rapidly dry wood. The liquid must be maintained at a temperature high enough to boil off the water. This process was patented by Curtis and Isaacs in 1895 and has found limited use in drying cane blanks and small tools handles. A modern modified process makes use of a vacuum which speeds up the process. This process has been used extensively to condition, but not to fully season timber prior to preservative treatment ( 3:1).

In the simple boiling in oil method the wood is submerged in a water repelling liquid, such as petroleum oil, creosote, or molten wax which has a boiling point considerably above that of water. The liquid is gradually heated until the temperature of the bath is somewhat above the boiling point of water. Some of the water in the wood is turned into vapor or steam. The steam comes to the surface of the wood and boils off. As the water near the surface boils off, more vapor is formed in the wood and diffuses to the surface. While there is bulk water in the wood cells, the boiling is very rapid for easily dried woods such as pine sapwood. The heat absorbed as the water vaporizes tends to keep the temperature of the wood near the boiling point of water. A thin film of nearly saturated water vapor protects the surface of the wood from the severe drying conditions of practically zero relative humidity in the oil itself. When the free water is gone from the cavities of the cells, the only water left is that

contained in the cell walls. This water comes out more slowly than the free water. The outer protective vapor layer becomes very thin, and the surface becomes subject to the severe conditions of the heating oil ( 3:1).

If the diffusion of water from the inside of the wood to the surface is fast enough checking may be prevented. With woods that water does not readily diffuse through, such as sweetgum heartwood, the wood soon is unable to provide enough water at the surface to protect itself from the severe drying conditions. The surface then begins to check. The high temperatures may cause honeycombing and severe casehardening. Casehardening must then be alleviated by reconditioning the lumber in a kiln. Another disadvantage of the boiling in oil process is uneven heating of the oil which will cause uneven drying ( 3:2).

Most of our woods will check under the very severe drying conditions of boiling in oil unless a vacuum is used. Softwoods which can be dried rapidly by this method can also be dried by other means, thereby eliminating drying in oil as a practical method of seasoning lumber ( 3:3).

The McDonald process is a more complicated variation of the boiling in oil method and uses a commercial dry cleaning solvent, perchloroethylene, in a closed chamber. The solvent is reclaimed after it boils off in a condenser to be used again ( 3:4).

6. High Frequency Dielectric Heating was first used by a Russian Abramenko in 1934. There has been relatively little research done in this area because of the limited uses which this method appears to have at the present time.

Dielectric heating requires generating apparatus capable of setting up an electric field that will oscillate at a high frequency between the condenser plates or electrodes. Wood placed in a powerful electric field oscillating at more than one million cycles per second is heated quickly, throughout, to a temperature above the boiling point of water. If the wood species were very porous, with no resistance to the movement of free water or vapor, it could be dried rapidly, but wood, in general, is not very porous. Moisture does not move rapidly through woods which have a tight cell structure as many woods do. This impediment of moisture can cause high internal temperatures and pressures well above the boiling point of water and consequently causes local explosions which

may split the wood wide open ( 9:1).

Apart from splitting difficulties the high cost of operating the electronic equipment makes this method impractical for use in the United States ( 9:2).

7. Salt Seasoning is one method which consists of treating the lumber prior to seasoning in such a way that the drying process as carried out by ordinary ways is accelerated and simplified. This method uses the following principle:

When a chemical is dissolved in water, the vapour pressure of the solution is lower than the normal vapour pressure of water. This means that where as air which is less than saturated will evaporate water, it will not evaporate moisture from the solution we are discussing until the humidity is below the point at which it will be in equilibrium with the vapour pressure of the solution. This point is considerably below 100% humidity. Saturated salt solution remains unaffected until the humidity of the air has fallen to 75% ( 1 :131).

A piece of wood soaked in the saturated salt solution can be placed in an atmosphere of 75% humidity without drying. But if only the outside layers are saturated with the salt solution, the center will behave normally and will dry. It is desirable to have the inside dry before the outside to eliminate the external splits which normally develop. By regulating the surrounding atmosphere drying can be accomplished without splitting and can be carried out much more rapidly than would otherwise be possible ( 1:131-32).

8. Polyethylene Glycol 1000 can be use for chemically seasoning wood and preventing or reducing wood degradation. Forest Products Laboratory has done considerable research during the last nine years on using polyethylene glycol for preventing or reducing wood degradation that occurs when green wood is seasoned. Donald H. Gott, Secretary-Manager of the American Walnut Association indicates that:

Thanks to FPL development of the polyethylene glycol treatment this practical utilization of waste walnut limbwood opens up a new field of conservation and marketability of waste tree parts ( 7:1).

Chemical seasoning of wood has various assets for anyone who wishes to use this medium. This method of seasoning prevents waste of wood through checking, warping, and splitting. It provides a rapid means of seasoning green wood, and it allows the use of cross-sections and limb wood. Englerth of

**Forest Products Laboratory adds:**

One real advantage of using the nontoxic chemical is that it permits great latitude in the choice of projects as well as the selection of wood. At the Forest Products Laboratory, for example, we have made attractive bowls from lowgrade or "surplus" wood ( 6:56).

When freshly cut green wood is soaked for an appropriate period in a 30% to 50% (by weight) water solution of high molecular weight polyethylene glycol, the wood does not shrink appreciably when dried. Equally important, wood thus treated and then dried swells very little when exposed again to high humidities. This stabilizing treatment attacks the problem at its very roots by bulking the microscopic, lattice-like structure of the individual wood-fiber walls. Heavily treated wood is thus permanently restrained from shrinking, swelling, or warping, regardless of atmospheric humidity (17:3).

Polyethylene glycol may also be used as a chemical seasoning agent. Research has shown that relatively light treatments will effectively prevent seasoning degrade in green wood carvings, cross sections of logs, turnings, totem poles, and similar craft items. In this application the objective is simply to get enough polyethylene glycol into the outer shell to prevent splitting and checking during drying, rather than to obtain a uniformly high level of dimensional stability in the finished product (17:3).

Most of the carvings from tropical countries - Southeast Asia, Equatorial Africa, Latin America, and other areas of high humidity - are made of poorly seasoned wood that is only partially dry. This results in the majority of the carvings checking when they are brought into the United States or other low humidity countries within a period of several weeks. Forest Products Laboratory has been successful in preventing checking of imported carvings by:

. . . immediately soaking them in water for two weeks to restore them to the turgid green condition essential for satisfactory diffusion of the large molecules of polyethylene glycol into the structure of the cell walls. The carvings are then soaked from three to seven days, depending upon size and shape, in 50% solution of polyethylene glycol (13:476).

Another practical use of polyethylene glycol has been in the dimensional stability of rifle stocks for the United States Army by the Crane Creek Gun Stock Company. They emphasize that:

Crane Creek shrink-swell-and-warp-proof rifle stocks

are an example of the high level of dimensional stability attainable by heavy treatment with polyethylene glycol. Recent tests have shown that high-quality bolt action rifles fitted with stabilized stocks will maintain their zero (that is, their fine accuracy) whether used in the arid southwest, where ordinary stocks shrink until their metal fittings loosen, or following complete immersion in water for over a week (17:3).

Recently waterlogged boats were retrieved from the bottom of Lake George in New York and after being treated with polyethylene glycol 1000 they were successfully dried without the cracking or distortion shown on the group of untreated pieces from the same ship. These boats were sunk almost 200 years ago in the French and Indian War and being fully waterlogged they accepted the chemical treatment readily (20:649-50).

Dimensional stabilization requires a high degree of penetration of polyethylene glycol into the wood. To obtain high dimensional stability, a penetration of the chemical throughout the wood is required leading to a uniform uptake of 25% to 30% of the chemical based on the weight of the dry wood. The time required for this depends upon the thickness of the wood and may require several weeks. See Table I. Green gun stocks require six weeks. It is effective only on green wood or wood which has been thoroughly water soaked (14:1).

Reduction of checking during drying can be obtained with a less drastic treatment of the wood. Many times soaking over night in a 30% solution of the polyethylene glycol 1000 will prevent checking, but research is needed to determine the proper soaking schedules (14:2).

Polyethylene glycol can be purchased from many of the large chemical companies such as Dow Chemical Company, Midland, Michigan. Smaller lots may be purchased from Crane Creek Gun Stock Company, Waseca, Minnesota.

TABLE I

DIRECTIONS FOR THE TREATMENT OF CROSS SECTIONS OF GREEN LOGS AND LIMBWOOD TO PREVENT SPLITTING AND CHECKING

Solution concentration and temperature	Suggested period of soaking for:	
	Walnut disks up to 9" in diameter and 1-1½" thickness	Walnut disks over 9" in diameter and 2-3" thickness
30 percent, 70° F.	20 days	60 days
50 percent, 70° F.	15 days	45 days
30 percent, 140° F.	7 days	30 days
50 percent, 140° F.	3 days	14 days

## CHAPTER V

### SEASONING DEFECTS

That the user of wood cannot do anything about the defects that occur in wood during the seasoning process is understood. Why these defects occur and what their affects are to various species of woods will be discussed with the thought that the acquired knowledge will allow for more economical use and a better idea of how to work with or around these defects. Defects or degrade that sometimes appear due to seasoning may be classified into two groups: (1) that caused by unequal shrinkage and (2) that caused by the action of fungi.

Lumber has a high moisture content and is unsuited for most building purposes as it comes from the sawmill. Moisture content, commonly called sap, may vary from 30 to 300 percent of the oven-dry weight. It is important that lumber be seasoned until the moisture content is in equilibrium with the conditions which the wood will meet in service. When a condition of equilibrium moisture content is reached the lumber has no tendency to shrink, expand, or warp. Due to normal changes in atmospheric moisture, wood is virtually always undergoing at least slight changes in moisture content because of its tendency to come to a balance with the relative humidity of the surrounding air. ( 4:147).

#### SHRINKAGE

The major reasons for seasoning lumber are: (1) reduce weight, (2) reduce shrinkage, and (3) increase strength. By reducing weight we are actually changing the moisture content and as this varies so too do the dimensions of wood change. This change is brought about by the shrinkage of the wood. Green or freshly cut lumber starts to shrink as soon as drying starts and drying starts immediately after a tree is cut. This becomes noticeable only after the fiber saturation point is reached. "One of the prominent things about shrinkage is its variability. Shrinkage not only differs among the three directions of grain, tangential, radially, and longitudinal, but also among species" (16:5).

Softwoods shrink considerably less than hardwoods. Radial shrinkage is usually much less than tangential shrinkage, but the ratio between the two varies greatly. "Also, woods with a high specific gravity generally shrink the most.



Basswood, a light wood, has high shrinkage" (16:5). This variation in shrinkage extends to material cut from the same species and the same tree. Heartwood generally shrinks more than sapwood. The early wood of an annual ring shrinks more than the late wood of the same ring (16:5).

Although shrinkage is variable in normal wood, certain abnormal types of wood contribute to increased variability. Compression wood, which is common to softwoods, shrinks considerably more longitudinally but less transversely than normal wood. The strands of the fiber walls of compression wood make a large angle with the longitudinal axis of the fiber, rather than lying nearly parallel. Tension wood which is found in hardwoods, also has excessive longitudinal shrinkage, although the reason has not been determined. Particularly light weight wood of some species has a greater longitudinal shrinkage than heavier wood of the same species. This rule does not apply to light and heavy woods of different species. Cottonwood, a light wood, does not shrink appreciably more lengthwise than oak, a heavy wood (16:6).

The shrinkage or swelling in the width of a flat-grained board is nearly twice that of a quarter-sawn or edge-grained board of the same width, in all species of wood.

The cause of most of the defects that arise during seasoning can be traced to shrinkage. This decrease in dimension also causes cross-sectional changes and warping. The cross-sectional change is due to the difference in shrinkage in the radial and tangential directions. Another possible cause of the change is set, the result of drying stresses. A dry board that is thicker at the edges, and all faces of a square being concave may also be caused by set (16:8).

#### WARPING

Warping is responsible for much waste in fabricating and for some unsatisfactory service. Warping can be reduced to a minimum by the use of quarter-sawn dry material. The combined characteristics of warping and shrinkage determine the ability of wood to stay in place. Ability to stay in place, that is, remain flat, straight, and not change size, is desired in practically all uses. It is especially important in furniture and cabinetwork. All woods require proper seasoning in order to stay in place well (18:9).

Knowing where to place the blame is always satisfying and frequently useful. If lumber warps during drying

it is perhaps natural to blame only the drying conditions, or possible to conclude that air drying is better than kiln drying. Yet the fact is that a certain amount and kind of warp for a given species, size, and moisture content are unavoidable and can be cared for only by an allowance in thickness or width. As long as wood shrinks much of it will warp, and the more unevenly it shrinks, the greater will be the warp (22:7).

Warp caused by the difference in tangential, radial, and longitudinal shrinkage may be divided into cup, bow, crook, and twist. All plain-sawed boards would cup if allowed to shrink and dry without restraint. In a plain-sawed board, the position of the annual growth rings with respect to the two faces of the board is not the same, resulting in the outer face having a greater shrinkage potential than the face nearer the pith. Thus when the board shrinks and dries, the face nearest the bark tends to become concave while the opposite face tends to become convex (16:8).

Bow, crook, and twist may be caused by localized distortions of grain, ie: diagonal, spiral, or wavy grain, or by the presence of bands of abnormal wood such as compression wood.

#### CASEHARDENING

Shrinkage and the plasticity of wood are responsible for casehardening (16:8). It is a condition of stress and set in wood in which the outer fibers are under compressive stress and the inner fibers under tensile stress when the wood is uniformly dry (12:13, 14).

Whether casehardening is considered a defect or not depends upon the manner in which lumber is sawed or machined during fabrication. The more common fabrication difficulties that occur in the use of casehardened lumber are end checking, planer splitting, and warping. End checking will frequently develop in the core of a freshly crosscut casehardened board that is exposed to low relative humidity. Planer splits can occur in relatively flat casehardened boards coupled with the forces applied by the machine knives. If during any sawing or machining operation on a casehardened board the transverse or longitudinal stresses are unbalanced, distortion will result. In planing, the depth of cut is not likely to be the same on both faces; it will cup and the concave face will be the one most heavily cut. Any warping of casehardened stock that is due to sawing or machining is a source of trouble in fabrication and gluing ( 4:155).

Residual stress and set are not determinable by visual inspection and when resawing the wood will tend to cup toward the sawline. Special testing methods such as the prong test or slice methods are necessary to detect it and estimate its degree.

Sometimes the outside layers are under a tensile stress and the interior ones are under a compressive stress. This is called reverse casehardening and will be indicated when resawing by the boards cupping away from the sawline. This can be as serious as casehardening is when trying to fabricate articles (12:14).

#### CHECKS

During the seasoning process, shrinkage causes stresses that may, among other things, cause surface, end, and honeycomb checking. A separation of wood fibers extending both radially and longitudinally is called a check (16:8).

"Checking stems from the reduction of the surface moisture content to a value so low as to cause stresses that exceed the maximum tensile strength of the wood perpendicular to the grain" (12:10).

Checks generally originate at a point of weakness in the wood structure, in mineral streaks, and in resin ducts. Thin, narrow flat-sawed stock is less prone to surface check than thick, wide boards.

Some hardwood surface checks close up during the drying process.

Checks that have closed may escape detection, but the weakness is still present because the bond between the fibers has been broken. In products requiring highly finished wood surfaces, such as some types of interior trim, cabinets, and furniture, closed surface checks are undesirable ( 4:147).

Surface checks cause a great amount of waste if they do not show up in fabrication until many high-cost operations have been performed. These checks may even remain hidden until opened by humidity change after the article has been in use for some time.

Honeycombing or honeycomb checks are similar to end or surface checks and are a separation of the fibers that occur

in the interior. "The most common form develops along wood rays of flat-sawed stock, but in quarter-sawed Douglas-fir and some other woods it may occur in the form of ring separation" (12:11).

Honeycombed lumber is unsuitable for any use when high strength is required. It is also unfit for fabricating articles, since resawing, planing, and working will expose the interior checks. Severe honeycomb usually can be detected in rough lumber by visual inspection because of characteristic depressions running lengthwise on the lumber surface. In many instances, however, ordinary honeycombing is not visible until the lumber is crosscut, resawed, or ripped (12:13).

#### COLLAPSE

Collapse is a distortion of wood cells. A slight amount of this defect may be impossible to detect. When it is bad the surfaces of the wood will have grooves or corrugations.

Collapse may be caused by compressive drying stresses on interior parts of the wood that exceed the compressive strength of the wood or liquid tension in cell cavities completely filled with water. This defect is generally associated with excessively high dry-bulb temperature in the early stages of drying (12:11).

#### KNOTS

"Knots are by far the commonest defect in all lumber, comprising on the average from 70 to 80 percent of all defects in the common grades" (18:32).

Three ways that knots may affect the piece that they occur in are: appearance, strength, and tightness. In appearance, unless a knotty finish is required, they are considered objectional. The strength of a knot hole will decrease the strength of a board less than an intergrown knot of the same size. In tightness intergrown knots rank first, because they are so fixed that they will not come out under ordinary conditions.

A knot is a branch, or limb, embedded in a tree that has been cut through in the process of lumber manufacture. If the sawed section is oval or circular it is known as a round knot. A branch, or limb, which in the process of lumber manufacture has been sawed in a lengthwise direction is known as a spike knot. A sound, tight knot is solid across its face, fully as hard as the surrounding

wood, shows no signs of decay, and is so fixed by growth or position that it will firmly retain its place in the piece. (18:30).

Knots are further classified as intergrown or encased. As long as a limb remains alive, there is continuous growth at the junction of the limb and the trunk of the tree, and the resulting knot is called intergrown; after the limb has died, additional growth on the trunk encloses the dead limb and an encased knot results (18:30).

#### FUNGUS

Three defects that are associated with fungus are sap stain, decay, and mold. Most decay occurs in wood having a moisture content above the fiber saturation point. Wood that is continuously water soaked or continuously dry will not decay. Usually, wood maintained at 20 percent moisture content or less, typical of air-dried wood, is safe from fungus damage. Molds and stains are confined largely to sapwood and are of various colors.

Stains penetrate into the sapwood (not heartwood) and cannot be removed by surfacing. "Blue" stains vary from bluish to bluish black and brown with are the most common (24:381).

Extractives in wood undergo chemical changes during drying that may cause discolorations - or chemical stains, as they are generally called. If pitch fails to harden or set during drying, trouble may result, particularly with products to which sealers, varnishes, and paints are applied (4:152).

Brown stain is a chemical stain that occurs in many softwoods though principally in sugar, ponderosa, and white pine. Its color varies from light to very dark brown. While it affects appearance it does not impair strength. It is believed to be caused by chemical reactions that take place in the water-soluble extractives as they are concentrated and deposited during drying. The stain develops within the piece as well as on its surfaces. Planing may remove some of the stain but it may expose zones of darker stain (4:152).

## RECOMMENDATIONS

The following are recommendations made by Forest Products Laboratory in Report Number 1655 after reviewing and reaffirming their previous information.

1. Use lumber that is dried to a moisture content close to the midpoint between the high and low values the wood will attain while in service. Lumber should be equalized and conditioned by the supplier.
2. Interior woodwork, such as trim, flooring, panels, and cabinet work, should be kiln dried. Material for furniture, cabinets, case goods, musical instruments, tool handles, turning stock, and sporting goods should be kiln dried to an average moisture content between 5 and 8 percent.
3. Air-dried lumber is suitable for items that are not ordinarily subjected to artificial heat or for use in structures in which some shrinkage can be tolerated.
4. Green lumber should be limited to uses where it is maintained at a high moisture content or where shrinkage has been considered in the design of the structure. When used, precautions should be taken to prevent decay.

**TOPIC:**

Moisture Meters

**OBJECTIVE:**

To have the student learn the use and application of a moisture meter.

**INTRODUCTION:**

The use of a moisture meter can be a very useful adjunct in the selection of boards that are to be glued-up for a large flat surface. Matching boards of almost identical moisture content can help to keep warping to a minimum during fabrication time.

**EXPLAIN:**

Important electrical properties of wood.  
Effect of moisture content.  
Effect of moisture gradient.  
Resistance type moisture meter.  
Radio-frequency type moisture meter.

**DEMONSTRATE:**

Use of a moisture meter.  
Adjustments of meter controls.  
Application of electrode.  
Reading meter.  
Application of correction factor.

**STUDENT APPLICATION:**

Divide class into teams of two each. Have each team select a sample board and take reading and record. If possible save sample and have a reading taken after two or more days of rain and compare with first reading.

**EQUIPMENT AND MATERIAL REQUIRED:**

A commercial or other type moisture meter  
A supply of various species of wood

**TOPIC:**

Testing for a Stress Condition

**OBJECTIVE:**

To have the student learn a method of determining the condition of stress.

**INTRODUCTION:**

Casehardening is a stressed condition in a piece of wood characterized by compression in the outer layers of wood and tension in the center. Whether this is considered a defect depends on the final use and the manner in which the piece is to be sawed or machined during fabrication. It is important to know that end checks, planer splits, bowing or cupping may occur and how to check for these possibilities prior to fabrication.

**EXPLAIN:**

The different possible results when sawing or machining a piece of casehardened wood.  
Where to obtain sample for determining condition of stress.

**DEMONSTRATE:**

How to cut prong-type stress test sections.  
How to determine condition of stress.

**STUDENT APPLICATION:**

Instead of having each student cut a prong-type test section this check can be incorporated into the selection of material to be used in fabricating any particle or project.

**EQUIPMENT AND MATERIAL REQUIRED:**

A supply of various species of wood  
Standard power equipment and tools



**HAND OUT SECTION**  
**and**  
**SUGGESTED TEACHING AIDS**

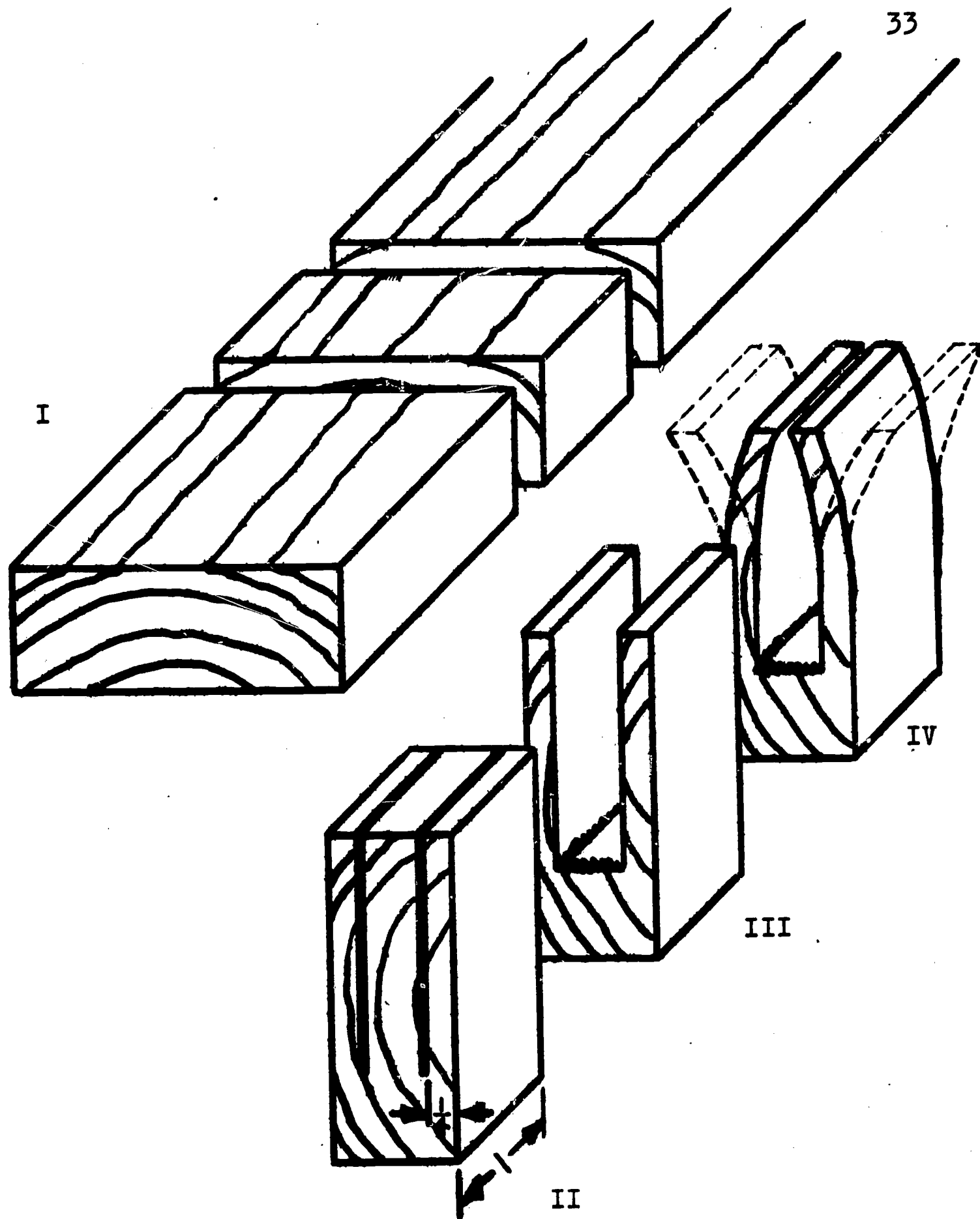

- I. Cut a section at least one foot in from the end of the board.
- II. Make two saw cuts in the section.
- III. Chip out the entire center portion.
- IV. If the prongs spring in, the timber is casehardened. Longer conditioning time is required. If the prongs spring outward (per dash lines), the timber is reverse casehardened. Less conditioning time is required or conditioning at a lower relative humidity.

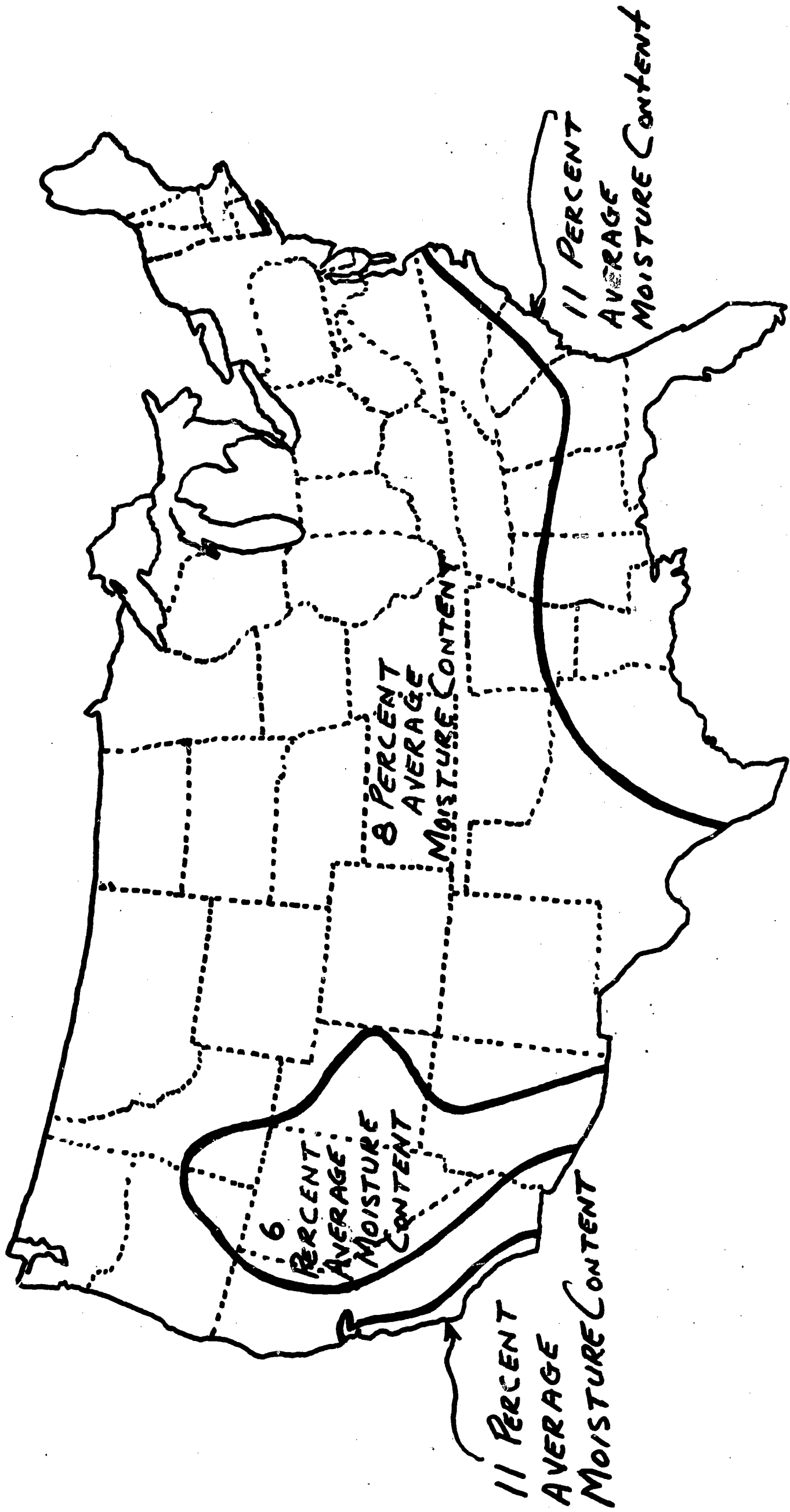

RECOMMENDED MOISTURE CONTENT AVERAGES FOR INTERIOR FINISHING WOODWORK FOR USE IN VARIOUS PARTS OF THE U.S.A.

TABLE I

DIRECTIONS FOR THE TREATMENT OF CROSS SECTIONS OF GREEN  
LOGS AND LIMBWOOD TO PREVENT SPLITTING AND CHECKING

Solution concentration and temperature	Suggested period of soaking for:	
	Walnut disks up to 9" in diameter and 1-1½" thick- ness	Walnut disks over 9" in diameter and 2-3" thick- ness
30 percent, 70° F.	20 days	60 days
50 percent, 70° F.	15 days	45 days
30 percent, 140° F.	7 days	30 days
50 percent, 140° F.	3 days	14 days

SHRINKAGE VALUES OF COMMON WOODS BASED  
ON DIMENSIONS WHEN GREEN

SPECIES	SHRINKAGE								
	Dried to 20% moisture content			Dried to 6% moisture content			Dried to 0% moisture content		
	R(1)	T(2)	V(3)	R	T	V	R	T	V
	%	%	%	%	%	%	%	%	%
<b>SOFTWOODS</b>									
<b>Cedar</b>									
Incense	1.1	1.7	2.5	2.6	4.2	6.1	3.3	5.2	7.6
Eastern red	1.0	1.6	2.6	2.5	3.8	6.2	3.1	4.7	7.8
Western red	.8	1.7	2.3	1.9	4.0	5.4	2.4	5.0	6.8
<b>Douglas-fir</b>									
Intermediate type	1.4	2.5	3.6	3.3	6.1	8.7	4.1	7.6	10.9
<b>Fir</b>									
California red	1.3	2.4	4.1	3.2	5.8	9.8	4.0	7.2	12.2
White	1.1	2.4	3.3	2.6	5.7	7.8	3.2	7.1	9.8
<b>Pine</b>									
Eastern white	.8	2.0	2.7	1.8	4.8	6.6	2.3	6.0	8.2
Ponderosa	1.3	2.1	3.2	3.1	5.0	7.7	3.9	6.3	9.6
Sugar	1.0	1.9	2.6	2.3	4.5	6.3	2.9	5.6	7.9
Western white	1.4	2.5	3.9	3.3	5.9	9.4	4.1	7.4	11.8
<b>Redwood</b>									
Old-growth	.9	1.5	2.3	2.1	3.5	5.4	2.6	4.4	6.8
Second-growth	.7	1.6	2.4	1.8	3.9	5.7	2.2	4.9	7.1
<b>HARDWOODS</b>									
<b>Alder</b>									
Red	1.5	2.4	4.2	3.5	5.8	10.1	4.4	7.3	12.6
<b>Ash</b>									
Black	1.7	2.6	5.1	4.0	6.2	12.2	5.0	7.8	15.2
White	1.6	2.6	4.5	3.8	6.2	10.7	4.8	7.8	13.4
<b>Aspen</b>									
Quaking	1.2	2.2	3.8	2.8	5.4	9.2	3.5	6.7	11.5
<b>Birch</b>									
Paper	2.1	2.9	5.4	5.0	6.9	13.0	6.3	8.6	16.2
Yellow	2.4	3.1	5.6	5.8	7.4	13.4	7.2	9.2	16.7
<b>Cherry</b>									
Black	1.2	2.4	3.8	3.0	5.7	9.2	3.7	7.1	11.5

## SHRINKAGE VALUES (cont.)

SPECIES	SHRINKAGE								
	Dried to 20% moisture content			Dried to 6% moisture content			Dried to 0% moisture content		
	R(1)	T(2)	V(3)	R	T	V	R	T	V
	%	%	%	%	%	%	%	%	%
Elm									
American	1.4	3.2	4.9	3.4	7.6	11.7	4.2	9.5	14.6
Luan									
Red	1.1	2.7	3.9	2.6	6.4	9.4	3.3	8.0	11.7
Mahogany	1.2	1.7	2.7	2.9	4.0	6.4	3.6	5.0	8.0
Maple									
Black	1.6	3.1	4.7	3.8	7.4	11.2	4.8	9.2	14.0
Silver	1.0	2.4	4.0	2.4	5.8	9.6	3.0	7.2	12.0
Sugar	1.6	3.2	5.0	3.9	7.6	11.9	4.9	9.5	14.9
Oak									
California black	1.2	2.2	4.0	2.9	5.3	9.7	3.6	6.6	12.1
Northern red	1.3	2.7	4.5	3.2	6.6	10.8	4.0	8.2	13.5
White	1.8	3.0	5.3	4.2	7.2	12.6	5.3	9.0	15.8
Sweetgum	1.7	3.3	5.0	4.2	7.9	12.0	5.2	9.9	15.0
Teak	.8	1.4	2.3	1.8	3.4	5.4	2.3	4.2	6.8
Walnut									
Black	1.8	2.6	4.3	4.4	6.2	10.2	5.5	7.8	12.8
Willow									
Black	.9	2.7	4.8	2.1	6.5	11.5	2.6	8.1	14.4
Yellow poplar	1.3	2.4	4.1	3.2	5.7	9.8	4.0	7.1	12.3

- (1) Radial  
(2) Tangential  
(3) Volumetric

(How Wood Shrinks and Swells, #1099:3-5)

DRYING DEFECTS OF MAJOR CONCERN  
IN COMMON COMMERCIAL WOODS

SPECIES	SOFTWOODS	MAJOR DRYING DEFECTS
<b>Cedar</b>		
Incense . . . . .		Collapse. Surface checking in flat-sawed 12/4 or thicker stock.
Eastern red . . . . .		Checking in and around knots. Excessive loss of aromatic oils.
Western red . . . . .		Collapse and honeycomb, particularly in sinker stock.
<b>Douglas-fir</b>		
Intermediate type . . . . .		Loose and checked knots. End-check penetration resulting in internal failures in thick stock. Ring failure in quarter-sawed lumber.
<b>Fir</b>		
California red . . . . .		End and surface checks. Water pockets.
White . . . . .		End and surface checks. Water pockets.
<b>Pine</b>		
Eastern white . . . . .		Brown stain. Water pocket. End and surface checks in 8/4 and thicker stock.
Ponderosa . . . . .		Brown stain. Checked knots. End and surface checks in 8/4 and thicker stock.
Sugar . . . . .		Brown stain. End and surface checks in 8/4 and thicker stock.
Western white . . . . .		Brown stain. End and surface checks in 8/4 and thicker stock.
<b>Redwood</b>		
Light and medium . . . . .		End and surface checks in 8/4 and thicker stock.
Sinker . . . . .		Collapse and honeycomb.
<b>HARDWOODS</b>		
<b>Alder</b>		
Red . . . . .		Sticker marking.
<b>Ash</b>		
Black . . . . .		Surface checks, particularly in 6/4 and thicker stock.

## DRYING DEFECTS (cont.)

SPECIES	MAJOR DRYING DEFECTS
White . . . . .	End and surface checks. Honeycomb, particularly in 6/4 and thicker stock.
Aspen . . . . .	Collapse in "wet wood". Water pocket.
Birch	
Paper . . . . .	End checks. Brownish chemical stain.
Yellow . . . . .	End and surface checks. Col- lapse and honeycomb.
Cherry	
Black . . . . .	Honeycomb in 8/4 or thicker stock. Surface checks.
Elm	
American . . . . .	End and surface checks in 8/4 and thicker stock.
Mahogany . . . . .	End and surface checks in thick stock.
Maple, sugar	
Normal . . . . .	End checks in 8/4 and thicker stock. Honeycomb, usually associated with end-check pene- tration, in thicker stock. Chemical stain.
Mineral streaked . . . . .	Checking. Collapse. Honeycomb.
Oak	
California black . . . . .	End and surface checks. Honey- comb.
Red . . . . .	End and surface checks. Honey- comb particularly in 8/4 and thicker stock.
White . . . . .	End and surface checks. Honey- comb particularly in 8/4 and thicker stock.
Sweetgum (heartwood) . . . . .	Honeycomb. Collapse. Water pocket.



## DRYING DEFECTS (cont.)

SPECIES	MAJOR DRYING DEFECTS
Walnut Black . . . . .	End checks. Honeycomb, usually associated with end check penetration in 6/4 and thick stock.
Willow Black . . . . .	End checks. Honeycomb.
Yellow poplar . . . . .	End checks in 10/4 and thicker stock.

(Dry Film Operator's Manual:156,57)

## GLOSSARY

- Active drying season** The season with a high temperature and low relative humidity, usually from spring to early fall.
- Alleys** There are three types in an air-drying yard; main, cross, and rear. The first two are used for transportation and working areas while the last is used primarily for the movement of air.
- Bow** Is the deviation flatwise from a straight line drawn from end to end of a piece.
- Casehardening** A condition of stress and set in wood which the outer fibers are under compressive stress and the inner fibers under tensily stress, the stresses persisting when the wood is uniformly dry.
- Casehardening, reverse** A final stress and set condition in which the outer fibers are under tensile stress and the inner fibers under a compressive stress as a result of overconditioning.
- Charge** A stack or stacks of lumber in a kiln for drying.
- Checking** A lengthwise separation of the wood usually extending across the rings of annual growth and commonly results from stresses set up in wood during seasoning.
- Compartment kiln** A dry kiln in which the total charge is dried as a single unit. At any given time the temperature and relative humidity are uniform throughout the kiln.
- Conditioning treatment** A controlled high temperature-high relative humidity condition used in a dry kiln after the final stage of drying to bring about a uniform moisture distribution in the charge and to relieve drying stresses.

## GLOSSARY (cont.)

Crook	(sometimes called spring) Deviation edgewise from a straight line drawn from end to end of a piece.
Cup	Deviation crosswise from a straight line drawn from edge to edge of a piece.
Depression, wet bulb	Difference between the dry and wet bulb temperatures.
Dry bulb	A thermometer that is not affected by vapor or moisture.
Equilibrium moisture content	Moisture content at which wood neither gains nor loses moisture when surrounded by air at a given relative humidity and temperature.
Equalization	Bringing the pieces of lumber in a kiln charge to a nearly uniform moisture content.
Fiber saturation point	Stage in the drying or setting of wood at which the cell walls are saturated with water and the cell cavities are free from water. Approximately 30% moisture content based on oven-dry weight.
Forced-circulation	Mechanical circulation of air in a kiln.
Flues and chimneys	Spaces left between the edges of the boards for the downward movement of air.
Gradient, moisture	A condition of graduated moisture content between successive thickness zones of wood that may be losing or absorbing moisture.
Hand-stacked piles	Packages built at or near a mill in a stacking rack or jig.
Honeycombing	Checks, often not visible at the surface that occur in the interior of wood usually along the rays.

## GLOSSARY (cont.)

Humidity, relative	Ratio of amount of water vapor present in air to that which the air would hold at saturation at the same temperature.
Hygroscopicity	Property of a substance which permits it to absorb and retain moisture.
Kiln sample	A section of wood pulled from the charge prior to entrance in a kiln that has its moisture content checked for a drying schedule.
Manually controlled	Manual control of ventilation by the use of valves and ventilators.
Moisture section	A cross section, 1 inch in length across the grain, cut from a kiln or random sample and used to determine moisture content.
Natural-circulation	Air circulation depending upon power of gravity and varying density of air with changes in its temperature and moisture content.
Oven-dry	Term applied to a sample that is oven-dried to a constant weight in a temperature from 214° to 221°.
File bottoms	Well built foundations for yard piles high enough off the ground to allow escape of air that has circulated through the pile.
File roof	An essential feature of good air-drying practice that shields the upper courses and to a lesser extent, the lower part of the pile from direct sunshine and precipitation.
Polyethylene glycol 1000	P.E.G. 1000 is a white, waxlike chemical that resembles paraffin. It is a solid at room temperature, melts at 104° F., has a molecular weight of 1000, dissolves readily in water, is nontoxic, noncorrosive, and has a very high (580° F.) fire point.

## GLOSSARY (cont.)

Progressive kiln	A kiln in which the total charge is not dried as a single unit but as several units as they move through the kiln.
Set	A localized semipermanent deformation in wood caused by internal tensile and compressive stresses.
Seasoning degrade	Degradation which appears during the seasoning process. Classified into 2 main groups: (1) that caused by the unequal shrinkage, which includes checks, honeycomb, warp, loosening of knots, and collapse; and (2) that caused by the action of fungi, namely; molds, stains, and decay.
Shrinkage	Contraction of wood caused by drying the material below the fiber saturation point.
Twist	Rise of a fourth corner above the plane of the other three corners.
Wet bulb	Registers moisture and humidity of the kiln.

## SELECTED BIBLIOGRAPHY

1. Bateson, R.G., Timber Drying, London: Crosby, Lockwood and Sons, 1952.
2. Bethel, James S., Lumber, New York: John Wiley and Sons, Inc., 1958.
3. "Boiling in Oily Liquids", Report No. 1665, Forest Products Laboratory, Madison, Wisconsin.
4. Coleman, Donald F., Agriculture Handbook, No. 188, U.S. Department of Agriculture.
5. Dry Kiln Operator's Manual, No. 188, Forest Products Laboratory, Madison, Wisconsin.
6. Englerth, George H., "Bowls From Scrap Wood and PEG", Workbench, 23:56, July-August, 1967.
7. Gott, Donald H., "PEG-Treated Walnut Limbwood Makes Handsome Decorator Clock", FPJ Technical Note, Madison, Wisconsin: Forest Products Laboratory, September, 1963.
8. Henderson, Hiram L., The Air Seasoning and Kiln Drying of Wood, 1951.
9. "High Frequency Dielectric Heating", Report No. 1665-7, Forest Products Laboratory, Madison, Wisconsin.
10. "High Temperature Drying", Report No. 1665-1, Forest Products Laboratory, Madison, Wisconsin, 1957.
11. "Infrared Radiation", Report No. 1665-4, Forest Products Laboratory, Madison, Wisconsin, July, 1956.
12. McMillen, J.M., Stresses in Wood During Drying, Report No. 1652, Forest Products Laboratory, U.S. Department of Agriculture.
13. Mitchell, Harold L., and Eugene W. Forbes, "Protect Imported Carvings with P.E.G.", Forest Products Laboratory, Madison, Wisconsin, October, 1962.
14. "Notes on the Treatment of Wood with Polyethylene Glycol", Forest Products Laboratory, Madison, Wisconsin, February, 1966.
15. Peck, Edward C., "Air Drying of Lumber", Forest Products Laboratory, U.S. Department of Agriculture, 1961.

## SELECTED BIBLIOGRAPHY (cont.)

16. Peck, Edward C., How Wood Shrinks and Swells, No. 1099, Forest Products Laboratory, U.S. Department of Agriculture.
17. "Polyethylene Glycol - The New Wood Stabilizer", General Catalog No. 6, Crane Creek Gun Stock Co., Inc., Waseca, Minnesota.
18. Properties, Selection, and Suitability of Woods for Woodworking, Forest Products Laboratory, U.S. Department of Agriculture.
19. Resch, H., and B.A. Ecklund, Accelerating the Drying of Redwood Lumber, Bulletin No. 803, Division of Agricultural Sciences, University of California.
20. Seborg, Ray M., and Robert B. Inverarity, "Preservation of Old, Waterlogged Wood by Treatment with P.E.G.", Science, Vol. 136, No. 3516, May 18, 1962.
21. Torgeson, O.W., Circulation of Air in a Dry Kiln, No. 1678, Forest Products Laboratory, Madison, Wisconsin, 1959.
22. Torgeson, O.W., Seasoning Dimension Stock, Report No. 1242, Forest Products Laboratory, U.S. Department of Agriculture.
23. "Vacuum Drying", No. 1665-4, Forest Products Laboratory, Madison, Wisconsin, November, 1956.
24. Wood Handbook, No. 72, Forest Products Laboratory, Madison, Wisconsin, 1955.

RESEARCH ON LAMINATES

---

Presented to  
Dr. Hammer  
San Diego State College

---

In Partial Fulfillment  
of the Requirements for the Course  
Industrial Arts 298

---

by  
James Harlow  
Norman Reading  
Howard Sala  
Belton Walker  
August 1968



## TABLE OF CONTENTS

CHAPTER	PAGE
INTRODUCTION . . . . .	1
I. BENDING SOLID STOCK . . . . .	3
Selecting Bending Stock . . . . .	3
Seasoning of Wood . . . . .	4
Plasticizing . . . . .	5
Removing Discoloration . . . . .	5
Methods of Bending . . . . .	5
II. METHODS OF BENDING LAMINATES . . . . .	7
Plasticizing . . . . .	7
Steaming . . . . .	7
Immersion . . . . .	7
Bending of Dry Stock . . . . .	8
Bending by Saw Kerf Method . . . . .	9
III. LAMINATED BEAMS . . . . .	10
Fastenings . . . . .	10
Construction . . . . .	10
Advantages . . . . .	12
IV. ADHESIVES . . . . .	13
Casein Glues . . . . .	14
Urea-formaldehyde Resin Glues . . . . .	14
Phenol-formaldehyde Resin Glues . . . . .	15
Resorcinol-formaldehyde Resin Glues . . . . .	15

CHAPTER	PAGE
V. PLASTIC LAMINATES . . . . .	16
Types of Laminates . . . . .	16
Core Stock and Adhesives . . . . .	17
Procedures . . . . .	18
VI. Applications . . . . .	21
Water Skis . . . . .	21
Ski Caul . . . . .	23
Clipboard . . . . .	24
Salad Servers . . . . .	26
Bending Jig . . . . .	29
End Pressure Clamp . . . . .	30
Plywood Construction . . . . .	31
BIBLIOGRAPHY . . . . .	32

## INTRODUCTION

The process of laminating wood has been known since the fifteenth century B. C. according to J. Hugh Capron (1:9). Glued laminated wood arch construction was originated by Hetzer in Germany in the early part of the present century. It was used in Europe for framing churches, railroad stations, factories and warehouses for some time before it was introduced in America.

The process mentioned above is still being used for such construction in Europe, where there is considerable current interest in enlarging the scope of the industry. In America, however, the widely accepted use of wood construction and the readily available lumber supply--not to mention the improved technical "know-how"--have enabled the laminating industry to outgrow its European counterpart. Freas (11:69) estimates the annual production of glued laminated wood structural material in America today to be approximately fifteen times that of Europe.

In the past few years, widespread developments in the field of glued laminated wood construction have encouraged engineers and architects to seek new applications for this type of product. In the wood fabrication industry the uses for laminated wood have been increasing rapidly and now include large beams used in building construction, component parts for boats, bowling pins, tennis racquets, ball bats, gun stocks, furniture parts and various other uses.

In general, wood laminating consists of the gluing together of pieces of wood with the grains running parallel rather than at right angles as used in plywood construction. Many laminated pieces are formed or bent to achieve a certain strength or shape. Therefore, any discussion of the techniques of lamination should also include problems related to the bending of solid stock.

The industrial arts woodworking teacher of today is faced with the challenge of guiding students who desire to produce projects that require basic laminated construction. It is the teacher's responsibility to relate pertinent information in this rapidly expanding field of technology to the students.

Too often when we think of wood lamination, and especially bent wood lamination, we think only in terms of matched, perfectly fitted, male and female forms used in conjunction with a press or set of clamps which is able to exert a great amount of pressure across the forms. When an industrial arts teacher takes this approach to wood lamination, he is likely to conclude that experience with wood laminating is just not feasible. This should not be the case. Bent wood lamination can be an exciting, dynamic and developmental educational experience even though exotic forms and pressure systems are not available. Preparations for laminating can include many forms as long as they meet the desired shapes or contours. No expensive presses or complex or even simple clamping systems are required. In terms of the school shop situation, this process has some distinct advantages over the "more conventional" methods of laminating.

It doesn't require a set of matched forms which, in most instances, the instructor would have to build. Because only one form is needed, students can build or find their own forms. Because students are not limited to a few sets of teacher-made matched forms, there is no inherent tendency for each student to be constructing virtually the same project. "Students have greater creative freedom and feel challenged to produce a greater variety of projects. In many instances when producing in small quantities, it is more expedient to form laminated shapes using this method than to use more 'sophisticated' laminating techniques." (8:69)

To producers of wood products, however, laminating is of much deeper significance. They herald the fact that a new wood-using industry is forging ahead with vigorous strides, winning markets for its production often in fields where wood is supposed to have been pushed into oblivion. That industry is the one we have come to call wood laminating. It consists essentially of bonding pieces of wood together either to "make big ones out of little ones," to produce members of unusual shape, or to combine woods with differing properties so that the best advantage is taken of each.

The material presented in this study is meant to provide the necessary technical information and some suggested student activities for the teaching of a unit in the lamination of wood products in an industrial arts laboratory.

## CHAPTER I

### BENDING SOLID STOCK

Many pieces of furniture, boats, sporting goods and construction items call for some curvature in form. These curved pieces may be shaped in either of two different methods. First, simple cutting usually done on a bandsaw is entirely satisfactory if the curve is slight. If the curve is too great then weakness occurs in the finished part because of the appearance of cross-grain. The other method of obtaining a curved piece is to bend it; whether it is solid stock or laminated from several pieces of thinner stock.

The bending of stock has several distinct advantages; the foremost being that the curved piece may be formed without any sacrifice of strength caused by cross-grain. The grain in a piece of bent, solid or laminated stock runs parallel to the edge of the piece throughout its length. Laminated stock is non-magnetic and resistant to fire, weather and corrosion, which greatly increases its practical uses (1:11).

There are some disadvantages as well to the bending of stock and the most important of these would be the breakage factor. Despite the knowledge gained in years of experience, there is no method that guarantees one hundred per cent success in the bending of wood. Commercial operators are plagued by the losses due to breakage during either the bending process or the fixing process which follows. There is a definite need for more information on the areas of selection of bending stock, the plasticizing of the stock, bending machines, and the effect of bending on the strength properties of the wood (11:1).

#### I. SELECTING BENDING STOCK

Bending qualities of various species of wood will differ greatly and the bending quality of different samples of the same species will vary. As a rule, the bending qualities of hardwoods are superior to those of softwoods, and

certain hardwoods have better bending qualities than others. Straight-grained wood is less likely to fail than is cross-grained wood, although the slope of the grain should not exceed one inch in fifteen inches of length. Knots should be avoided because of the distorted grain and their resistance to compression (11:1). Woods with splits, checks and other defects should be excluded.

The Forest Products Laboratory (3:359) recently found in an experiment in bending three-quarter inch hardwood squares on a twenty inch radius without end pressure or any support on the outside of the bend that the percentage of failure was as follows:

Oak, White	9%
Oak, Red	14%
Birch	22%
Elm	28%
Ash	36%
Beech	40%
Poplar, Yellow	51%
Maple, Hard	51%
Gum, Black	55%
Cottonwood	69%
Sycamore	84%
Basswood	95%

## II. SEASONING OF WOOD

The percentage of failures in the bending of wood can be greatly reduced by having the correct amount of moisture in the cell walls. Green wood will bend readily because the cells have some void space as well as some free water. If the cells contain too much water to permit compression in a severe bend, then wrinkles due to hydrostatic pressure will appear and excessive shrinkage and splitting will occur during the drying stage. If the wood is too dry, as is most kiln dried lumber, it is not sufficiently plastic to bend very well.

The moisture content of wood for the most successful bending should be between twelve and twenty per cent, and in some cases, may range as high as thirty per cent. It is well to remember that the convex side cannot be stretched more

than one to two per cent while the concave surface may be compressed as much as twenty per cent (2:555).

### III. PLASTICIZING

Wood may be softened by either steaming or soaking in water to achieve the desired moisture content for bending. Experiments have been conducted in liquid ammonia, but conditions necessary to achieve success by this method seem to make it impractical for the average school wood laboratory. The process of plasticizing will be dealt with more completely in the next chapter.

### IV. REMOVING DISCOLORATION

Many woods will discolor or take on a dull appearance after boiling or steaming. The discoloration may be caused by the tannic acid in the wood reacting with the iron in the bending straps, clamps, or soaking apparatus, particularly when hot wet oak comes in contact with iron, which causes a dark, purplish-black color. This discoloration normally does not penetrate deeply and sanding of the curved member will usually restore the original luster to the wood. A hot three per cent solution of oxalic acid will bleach the stains after the piece is completely dried. However, the solution should be sponged from the piece with clear water afterward (11:19).

### V. METHODS OF BENDING

Bending can be done in either of two general methods, each being successful if done within certain limitations. These two types are (1) free bending without end pressure and (2) bending with end pressure.

Free bending is done when only a slight curvature is to be achieved and the difference in length between the inner and outer faces of the bent piece is not greater than approximately three per cent. When the wood is steamed before being freely bent, the heat and moisture makes it possible for the inner, or concave surface, to assume a certain amount of compressive strain before the tension

strain on the outside, or convex surface, causes failure in the fibers (11:12,13).

Free bent wood, not being deformed a great deal, will not retain its shape perfectly after drying. It is advised that overbending in this case will help to retain the final curve desired.

Bending with end pressure is the method probably most used in industry. End pressure can be applied most easily by simply fastening blocks to a metal strap and accurately fitting the piece to be bent between the blocks. The metal strap is placed next to the convex side of the wood, and in reality, assumes most of the tension that would normally occur in this area. The blocks press upon the ends of the board forcing compression as the bend is made.



## CHAPTER II

### METHODS OF BENDING LAMINATES

There are four simple methods of bending wood: (1) steaming, (2) immersion in hot water, (3) dry bending, and (4) bending with saw kerfs. Plasticizing by steaming basically changes the fibers in the wood so that it becomes pliable.

#### I. PLASTICIZING

Steaming. The process of steaming need not include a great deal of high pressure equipment. Peck (11:11) states that wood is most effectively steamed at zero gage pressure up to sixty minutes and has fewer failures than wood steamed at a higher pressure. Steaming action seems to work more effectively when the wood is not immersed in water. We should therefore devise some method to keep the wood just above the water level. The water supply should be such that a constant amount is maintained throughout the steaming process.

The steaming or boiling period required is influenced by the thickness, moisture content, and species of the stock, and by the degree of plasticization needed, which is dependent on the severity of bend. Because these factors vary, it is not possible to specify exact steaming periods. Other things being equal, wet stock can be plasticized sufficiently by steaming for a shorter period than dry stock. Likewise, stock to be bent to a mild curvature can be steamed for a shorter period than stock to be bent to a severe curvature. It is also probable that different species become plastic at different rates, and therefore some species may need longer steaming periods than others. As a general rule, wet stock should be steamed or boiled 1/2 hour per inch of thickness and dry stock, 1 hour per inch of thickness (11:11).

Immersion. Immersing the wood in boiling water is a more convenient way of preparing the stock for bending

and is approximately equivalent to steaming, but has the advantage of plasticizing only the portion of the piece to be bent. Steaming is the preferred method of the two since coiling is apt to cause saturation of the cells which makes bending more difficult. Both processes cause discoloration in the wood.

The end grain of a piece of wood will tend to absorb more moisture than the rest of the grain during the steaming or boiling process, and as a result, will tend to split or end-check to quite an extent. This tendency may be reduced somewhat by end coating the boards with a moisture resistant covering, such as a wax or paint.

## II. BENDING OF DRY STOCK

Laminated curved members are produced from dry stock by bending and gluing together in one operation several comparatively thin pieces without softening them by steam or hot water. This process has the following advantages over the bending of single-piece members:

1. The laminations can be made so thin that bending to the required radius involves only moderate stress and deformation of the wood fibers; consequently, the use of steam or hot water is unnecessary and less subsequent drying and conditioning is required.
2. Because of the moderate stress induced in bending, stronger parts are produced.
3. The tendency of laminated members to change shape with changes in moisture content resulting from changes in relative humidity is less than that of single-piece bent members.
4. Ratios of thickness of member to radius of curvature that are impossible in bending single pieces can readily be obtained by laminating. Also, members having reversed curvature are more readily made by laminating thin plies, and curved parts of any desired length can be produced by staggering the joints in the laminations (7:303).

In the school shop, veneers are very satisfactorily used to produce laminated parts. Veneer is defined as a thin wood sheet from one-eighth inch (maximum thickness) to one thirty-second inch thickness. To save time and veneer

you should always use the thickest layers of veneer that will still bend easily to the form being used. Resawing of lumber is a good way in which to make veneer stock. The thinner the veneer the smaller radius to which it can be bent.

Veneered curved members are usually produced by gluing veneer to one or both faces of a curved solid wood base. The bases are ordinarily bandsawed to the desired shape or bent from a piece grooved with saw kerfs on the concave side at right angles to the directions of bend. Sometimes series of curved pieces are bandsawed contiguously from the same block of wood and reassembled in a gluing operation in the same relative position with glue-coated pieces of veneer between, thus producing a number of similar veneered curved pieces in one operation. Pressure is then applied to the whole series. In other assemblies single members are bandsawed to the desired curvature and then faced with a layer of veneer, and pressure is applied by means of flexible bands and clamps while the glue sets. Pieces bent by making saw kerfs on the concave side are commonly reinforced and kept to the required curvature by gluing splices, veneer, or other pieces to the curved base.

Veneering over curved solid wood finds use mainly in furniture. The grain of the veneer is commonly laid in the same general direction as the grain of the curved wood base. The use of crossband veneers, that is, veneers laid with the grain at right angles to the grain of the base and face veneer, reduces the tendency of the member to split (6:304).

### III. BENDING BY SAW KERF METHOD

The fourth method of bending wood is by the saw kerf method. Thick stock can be bent easier if a series of saw kerfs is cut on the concave side. This reduces the size of the surface by removing some of the stock rather than compressing it. However, the part that is produced here is weak and should be used only in assemblies where it can be securely attached to other supporting members. If cut too deep the saw kerfs could possibly be detected from the face of the board. However, if you cut approximately three-fourths way through the stock and put kerfs closer together you can eliminate this problem. The depth and spacing of the saw kerfs will vary with the kind of material and the radius of the bend (4:332).

## CHAPTER III

### LAMINATED BEAMS

Glued laminated wood can be used in a wide variety of structures such as buildings, bridges, aircraft and boats. Its versatility is enhanced by the fact that it can be made to required forms and sizes without regard to standard sizes and shapes and is free of the limitations commonly imposed on timber structures by the sizes and lengths of available solid material. Although large structures are usually laminated from material in lumber thicknesses, it has been found that laminating with veneer gives comparable results.

#### I. FASTENINGS

Some designers of glued laminated members have proposed that, in addition to the glue, mechanical fastenings be used for joining the laminations. It should be noted, if such a procedure is contemplated, that mechanical fastenings of all types can be expected to carry but little load until some relative movement of the joined parts has occurred. Glued joints will not permit the relative movement necessary to enable the mechanical fastenings to become fully effective, so that the use of mechanical fastenings to supplement the strength of the glued joints is impractical--they cannot be fully effective until the glue joint has failed, and even then cannot be expected to provide shear strength equivalent to that provided by the glue (9:89).

#### II. CONSTRUCTION

Beams of glued laminated wood may be either horizontally or vertically laminated. A horizontally laminated beam is one in which the loads on the beam act in a plane normal to the plane of the laminations, and is probably the most commonly used form. A vertically laminated beam, shown in Figure 1, is one in which the loads on the beam act in a plane parallel to the plane of the lamination. In the horizontally laminated type, edge joints in laminations that must be wider than the boards available need not necessarily be glued, since their strength normally will not

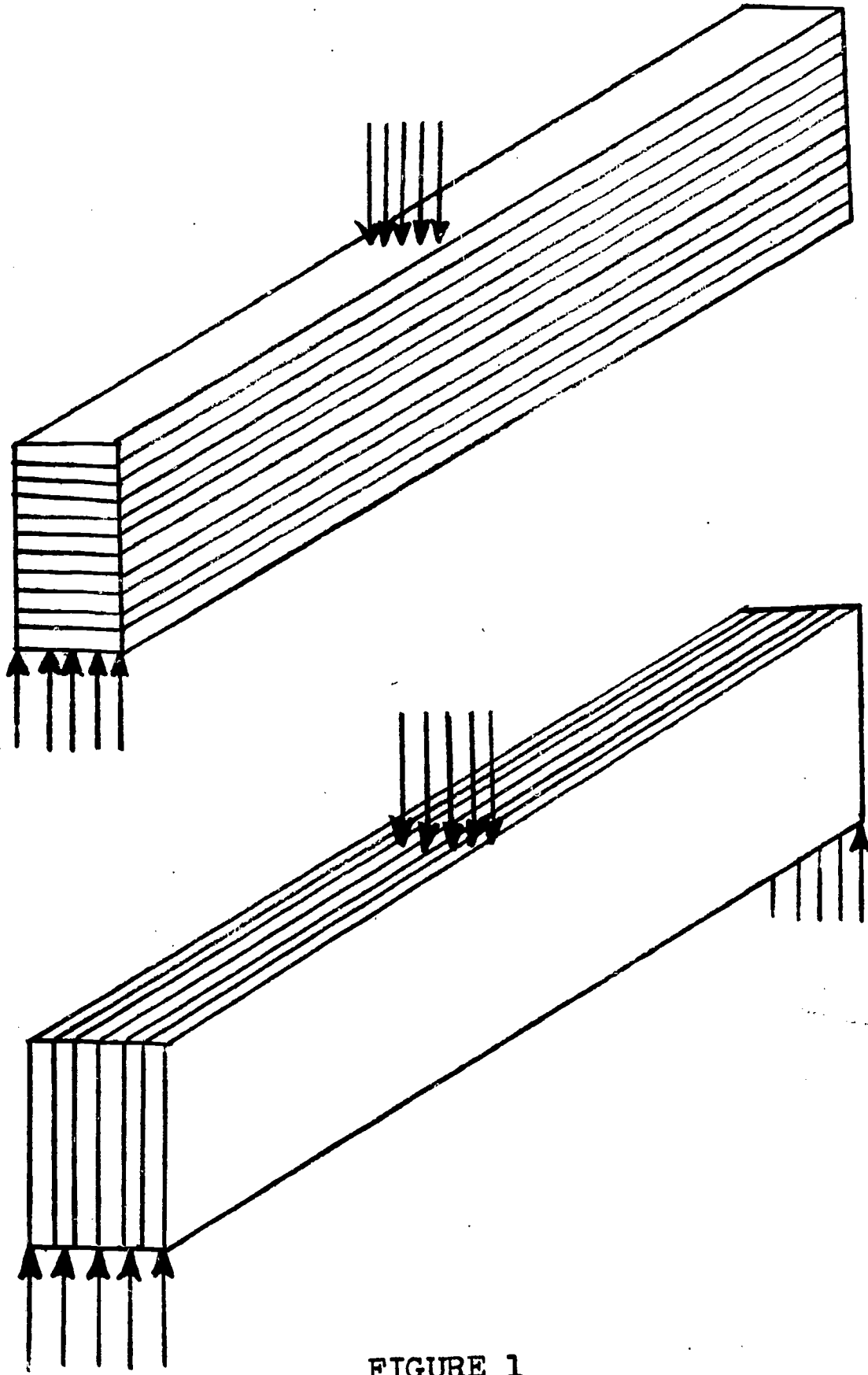

FIGURE 1

LAMINATED BEAMS  
A: HORIZONTALLY LAMINATED  
B: VERTICALLY LAMINATED

affect that of the beam. In the vertically laminated type, however, the strength of edge joints in laminations is of considerable importance, since their strength will affect the shear strength of the beam.

Glued laminated construction is particularly adapted to use in arches or in curved beams, since laminations can be used that are thin enough to permit bending them to the required curvature. Laminated arches are commonly designed as two-hinged or three-hinged. Arch designs involving fixed ends should give consideration to the fact that, over a period of time, the fixity may be reduced by working of the connections that results from deformations due to load and from shrinking and swelling due to changes in moisture content. Arches and other curved members are generally laminated horizontally. In form structures, vertically laminated arches of the type called "segmental arches" are sometimes used (9:89 - 91).

### III. ADVANTAGES

Laminated construction allows the architect a wide latitude in creating forms adapted to and expressive of the function and purpose of the structure and greatly extends the use of wood--the most abundant, beautiful and economical building material available. In addition to the flexibility in design, wood beam construction also provides a high fire resistance factor. Wood beams do not transmit heat like unprotected metal beams which lose their strength and quickly collapse under extremely high temperatures. Exposure of a wood beam to flame results in a very slow loss in its strength. It is weakened only in proportion to its slow reduction in cross section due to charring. This takes place very slowly and thus provides precious time in an emergency that may save life and material (6: Chap. 19 - 7).

## CHAPTER IV

### ADHESIVES

The glues in laminated wood products must have sufficient original bonding strength and durability to enable the glued member to perform as a structural unit throughout its service life. The service life of wood is usually determined by its resistance to decay and to other causes of deterioration. Although the glue bond of a laminated product must be equally resistant to deterioration, any superior resistance cannot be expected to extend the normal service life of the wood. Glues used for bonding must not damage or weaken the wood, and they should permit machining of the product without serious damage to surfacing equipment (9:16).

Prior to the development of synthetic resins, the glues most used in woodworking included the animal, vegetable-starch, casein, vegetable-protein and blood-albumin types. In recent years, however, an increasing number of synthetic-resin glues have become available. Their use has resulted in improved performances of many glued wood products and has facilitated the adaptation of glued products to new uses. Plywood for exterior uses, laminated wood for bridge timbers, ship keels and other members for use under severe service conditions are among those products.

Resin glues in most common use at present are the urea-formaldehyde and phenol-formaldehyde glues. Melamine and resorcinol-resin glues are among the latest developments, and the use of resorcinol-resins and phenol-resorcinol combinations is rapidly increasing, particularly for laminating. To a limited extent, emulsified vinyl-ester resins are finding specialized use as woodworking glues. A number of special synthetic-resin glues have also been developed for the bonding of wood and wood products to metals, plastics and other materials.

With the exception of the vinyl-ester resins, the synthetic-resin glues that have been used for bonding wood to wood are classified as thermosetting; that is, the

cured glued do not soften appreciably when exposed to temperatures that are higher than the original setting temperature. In general, any thermosetting glue can be made to harden or cure more rapidly by raising the curing temperature and thus decreasing the length of time required under pressure. Thermo-plastic resins, on the other hand, must first be heated to the point where they flow and then usually be cooled under pressure. Subsequent heating above the softening range will weaken them and permit joints to open. Because of their tendency to flow at elevated temperatures and to creep under sustained load, resins of this type are not recommended for laminated structural wood members. Since blood-albumin, vegetable-protein, vegetable-starch and animal glues are not suitable for the gluing of laminated structural members, they are not discussed in this paper.

### I. CASEIN GLUES

Casein glue is classed as water-resistant because of its relatively high resistance to moisture, compared with that of vegetable and animal glues. Its basic constituent is dried casein, which, combined with alkaline chemicals--usually lime and one or more sodium salts--is water soluble. Prepared casein glue comes in powder form, and, when mixed with water in the correct proportions is ready for use. It sets as a result of chemical reaction and of loss of moisture to wood and air. Well-made casein glue joints will develop the full strength of the wood, especially in softwood species and will retain a large part of their strength even when submerged in water for a few days.

### II. UREA-FORMALDEHYDE RESIN GLUES

Urea resins are available both as dry powders and in water as solid suspensions that ordinarily form sixty to seventy per cent of the mixture by weight. The powder forms are prepared for use by mixing with water to produce suspensions of approximately these concentrations. The powdered glues usually contain some filler, for which walnut-shell flour and wood flour are most commonly used, and mixing directions for the liquid glues normally call for the additions of some filler to improve their working properties. For certain types of plywood, urea resins



are extended with rye or wheat flour, primarily to lower cost, but the resistance of the glue to water and to attack by micro-organisms is thereby reduced. Although high joint strengths can be obtained in hot-press plywood with extended ureas, the value of extended glues for laminating lumber has not been established. Urea-resin glue joints in most woods are highly water-resistant at ordinary temperatures.

### III. PHENOL-FORMALDEHYDE RESIN GLUES

The phenol-formaldehyde glues may be classified, on the basis of setting-temperature requirements, as hot-setting and intermediate-temperature setting glues. Phenol-resin glues are formed by the reaction of phenol or cresol with formaldehyde. For the production of woodworking glues, the reaction is stopped at an intermediate stage, and the product is then marketed in the forms of a film with paper base, a dry powder or a suspension of resin in water-alcohol mixtures or other solvents. After the resin in either film or liquid form has been applied to the surfaces to be glued, the setting reaction is completed by the application of heat.

As a class phenol-resin glue joints are extremely durable over a wide range of moisture and temperature conditions. They are not attacked by micro-organisms and are highly durable under such adverse conditions as continuous soaking in fresh or salt water, continuous exposure at high humidity, cyclic exposures involving wetting and drying and exposure to high temperature at low and at high humidities.

### IV. RESORCINOL-FORMALDEHYDE RESIN GLUES

Resorcinol-formaldehyde resin glues have a combination of the moderate-temperature curing requirements of the urea resins and the high quality and durability characteristics of the phenol resins. These resins are produced by the reaction of resorcinol with formaldehyde and are marketed as liquids consisting of partly polymerized resin in a water-alcohol solution. The solids content of the solution is usually about sixty per cent by weight. The glue is dark red and makes dark joints when set. A hardener, usually paraformaldehyde but sometimes formalin, and a filler, commonly walnut-shell flour, are mixed with the resin prior to use. These glues are extremely waterproof (9:24).

3

## CHAPTER V

### PLASTIC LAMINATES

There is scarcely a home being built today that does not have a plastic laminate used somewhere in it. Plastic laminates are now extensively used in furniture construction, cabinets, counter tops, window sills and even as wall coverings. The woodworking instructor as well as the cabinetmaker or carpenter should thoroughly understand them and the uses to which they are put.

Plastic laminates are sold under various trade names such as Formica, Textolite, or Micarta; but are all produced in basically the same way. These high pressure laminated plastic surfacing materials are produced by assembling a "core" of several layers of kraft paper, a printed pattern sheet and an overlay containing a melamine resin. The layers, impregnated with resins, are fused together in a press at pressures of more than one thousand pounds per square inch and temperatures in excess of three hundred degrees Fahrenheit. This type of processing assures a product that will resist wear, burns, stains and soil; and which may be easily cleaned with only soap and water.

The teaching of a unit in plastic laminates need not involve expensive equipment or require such technical information as to place it beyond the reach of even a modestly equipped junior or senior high school shop.

#### I. TYPES OF LAMINATES

Laminated plastic is produced in three grades to meet specific requirements. They are as follows:

Standard Grade. This is a general purpose grade and is manufactured to a thickness of .062 or one-sixteenth of an inch. It is used for either vertical or horizontal application and is commonly found on desk tops, counters, tables and case goods. It can be used for edging and will bend to a radius of nine inches without heating and a two and one-half inch radius when heated.

Postforming Grade. The postforming grade is .050 inch or approximately one-twentieth of an inch in thickness. Special thermosetting resins that soften on reheating and papers that stretch are used in this product to permit small radius bending. This grade is used for rolled or formed counter tops, sill ledges and on small radius tables.

Vertical Grade. The vertical grade is .035 inch or one thirty-second of an inch thick and is designed primarily for vertical surface application such as sides of fixtures and door facings. This grade is cut into narrow bands one and five-eighths inches wide and sold as edge banding. When heated to 325 to 360 degrees, it can be curved to a three-fourths inch radius or it can be formed to a three inch radius at room temperature.

Plastic laminates are available in several different surface finishes, as follows:

Polished. These have a high gloss and are especially suited for areas where a smooth surface and luster are desired.

Suede. These have a fine-grained texture, with low reflective surface for both horizontal and vertical surfaces.

Furniture. A semi-gloss finish is achieved by special machining of the surface.

Laminates are available in virtually every color, many wood grains, simulated leather and stone patterns. They are also available in many novelty designs for card table tops, bar tops and pictures. Plastic laminates are sold by the square foot with the standard grade used as the base.

## II. CORE STOCK AND ADHESIVES

The core stock used under laminates is important in counteracting the brittleness that is characteristic of this type of product. It is recommended that when using plywood for core stock, a thickness of three-fourths inch is necessary for all horizontal applications and a minimum thickness of one-half inch on all vertical members. Some fabricators prefer to use Philippine mahogany plywood as core stock instead

of fir plywood because of a less prominent grain pattern. Laminates are also bonded to hardboards and particle boards that are three-sixteenths of an inch or thicker, for use in furniture construction (2:578).

Many adhesives, including the urea resins, casein, polyvinyl, and contact cement, can be used to bond laminates to core stock. Contact cement has one distinct advantage in that it requires no clamping pressure over a long period of time, as do the slow setting glues. This makes it more practical for an on-the-job application and is ideal for use in an industrial arts laboratory. If adequate ventilation is a problem, a water base latex contact cement may be used.

### III. PROCEDURES

The teaching of a unit on high pressure laminates requires very little equipment that a normal shop would not have. Laminates can be cut by scoring the face side with an ice pick or a scratch awl and bending the laminate upward until it breaks. It may be cut with a twelve-point crosscut saw, a hacksaw, a power saw or a portable router. This material may be drilled, planed or filed. Carbide tipped cutting tools are recommended because laminates dull the standard woodworking tools quite easily; however, carbide tools are not absolutely essential.

The procedures covered in a laminating unit should include gluing practices, edge treatments and trimming operations. These are basic to any project a student would select.

The type of edge treatment on a project must be decided upon before a laminate is bonded to the top. Shown in Figure 2 are the common types of edge treatments with the most popular being the edge-banding treatment. The top should be laminated to the core stock before any edges are applied except for the self edge or edge banding types. In these the edge is applied first and then the top is added later.

Edge banding is done by first smoothing the edges and then applying contact cement to both the edge and the laminate. The adhesive should be permitted to dry until all tackiness

disappears, but a little softness remains. Carefully position the strip and permit it to contact the edge. Great care must be taken in joining two pieces in this manner because once the surfaces touch there is an instant bond and no other positioning is possible (2:583). A more complete bond will be obtained if the edge is rolled with a small roller. The excess material may be trimmed off with a plane, hack saw, file or router. It is essential that the top of the banding be exactly flush with the top surface of the table to eliminate any open blue lines or high spots along the edge. An attachment may be purchased and mounted on a router along with special bits that will enable the trimming to be done very easily. If the trimming is done with hand tools, care should be taken that motion of the plane or file is toward the core stock and not away from it to prevent chipping of the laminate.

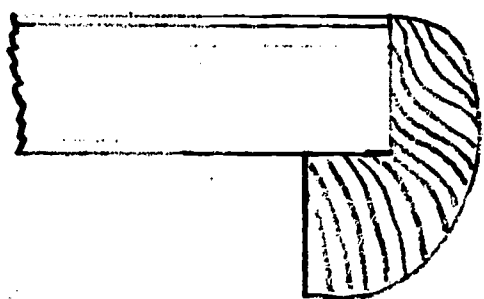

Shaped and dropped  
wood edge

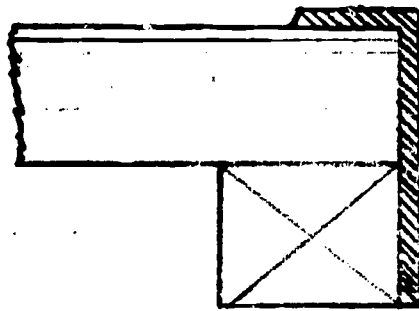

Extruded metal  
edge

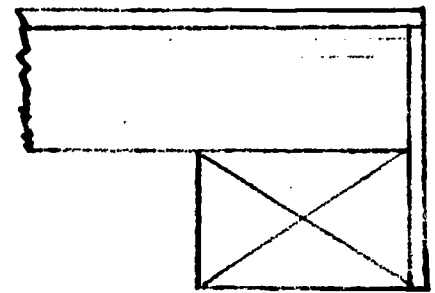

Edge banding

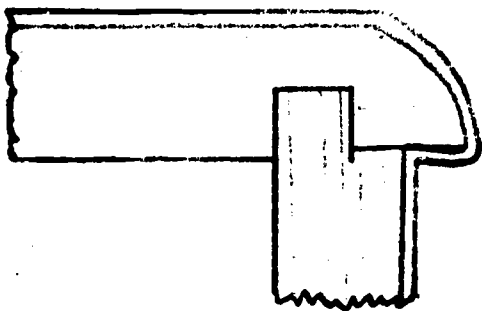

Postformed edge

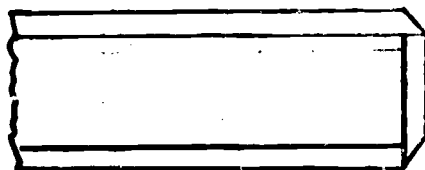

Self edge

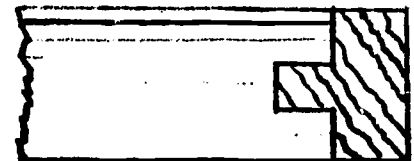

Wood edge

(2:582)

FIGURE 2

TYPES OF EDGE TREATMENTS

If the project has rounded corners, the laminate can be heated to approximately three hundred degrees and it will become pliable enough to form around the corner. If permitted to cool in this position it will retain its shape and then may be cemented to the edge of the core stock. A common heat lamp is a good source of heat and crayons that melt at specific temperatures are available. If the crayons are used, several lines should be drawn on the laminate at the place where the curve is to be; then when the lines begin to melt the edging is ready to be formed.

Application of a large piece of laminate to a top can cause problems unless some precautionary steps are taken to prevent contact before positioning of the piece is complete. Two common methods are: (1) to place several pieces of heavy wrapping paper on the top after the cement has dried, or (2) to place a number of thin dowels across the top. By withdrawing the paper a short section at a time or removing the dowels one at a time, the laminate can be controlled better as it comes down on the core stock. Using a small roller, and working from the center out to the edges, roll the laminate down firmly. Trim off the excess and file the edges smooth.

Laminates can be incorporated in many practical student projects ranging from clipboards and cutting boards to coffee tables and counter tops. With the widespread use of laminates today this is certainly an area that deserves attention in an industrial arts program.

## CHAPTER VI

### APPLICATIONS

#### Problem: Making water skis (See Figure 3)

##### Materials needed for each ski:

1. 1" x 6" white ash approximately equal to height of user
2. 1" x 1" x 12" white ash or oak for rudder
3. Three wood screws, #8 FL. HD. brass  $1\frac{1}{2}$ " long
4.  $\frac{1}{16}$ " x 6" x 15" light colored veneer
5. Small quantity of waterproof glue
6. Marine type finish as desired

##### Procedure:

1. Make template of desired shape.
2. Plane 1" x 6" ash to  $\frac{5}{8}$ " or  $\frac{3}{4}$ " thickness, depending on amount of flexibility desired.
3. Bevel faces of rudder stock such that bottom edge is  $\frac{5}{8}$ " thick and top edge is  $\frac{3}{4}$ " thick (optional shapes to suit taste or use).
4. Using band saw with resaw jig or fence, kerf 1" x 6" stock approximately 15" to facilitate bending as shown in drawing.
5. Using template, lay out ski.
6. Cut to shape on band saw, being careful to leave lines.
7. Plane to remove saw marks and produce exact shape.
8. Rough sand with 80 grit sand paper.
9. Plasticize wood to be curved by steaming for approximately one hour or by submerging in water for twenty-four hours.
10. Remove ski stock from water or steam and place in bending apparatus where it should remain until relatively dry and will retain its shape.
11. When stock is dry, spread glue on both faces of veneer and insert into kerf.
12. Replace in bending apparatus as in step 10. As a precaution against bonding to caul, place wax paper between ski stock and each part of caul.
13. Allow ample drying time, then remove ski stock from bending apparatus and reshape curved end with spoke shave, smoothing plane or other desirable tool.
14. Do final sanding operation.

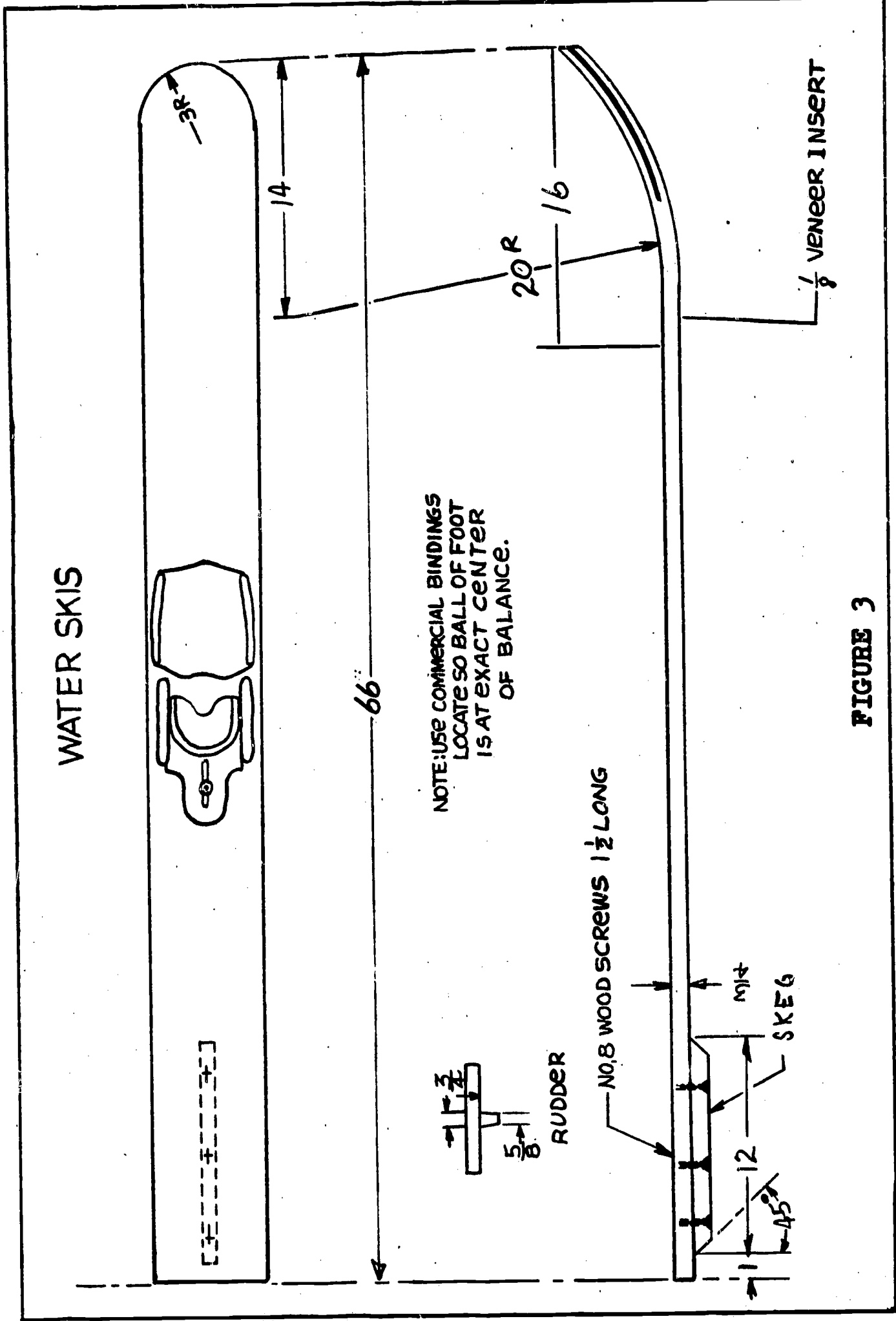

FIGURE 3



15. Drill pilot holes and attach rudder.
16. Apply minimum of two coats of desired marine type finish.
17. Drill pilot holes for commercial bindings so ball of foot is located at balance point of ski.
18. Attach bindings.

**Problem: Making and using a ski caul**

**Materials needed:**

1. Caul or bending jig made from solid timber or laminated block approximately 7" x 7" x 24"

**Procedure for making caul:**

1. Lay out desired curve on block as shown in Figure 4.
2. Using band saw, carefully cut to form two parts of caul.
3. Sand if necessary.
4. Line insides of caul with pad of rubber or cork.

**Procedure for putting pressure on caul:**

1. Place one large C-clamp near rear of caul and exert moderate pressure.
2. Place second clamp near front of caul and tighten to begin bend.
3. Tighten both clamps simultaneously until even pressure has closed kerf in ski.

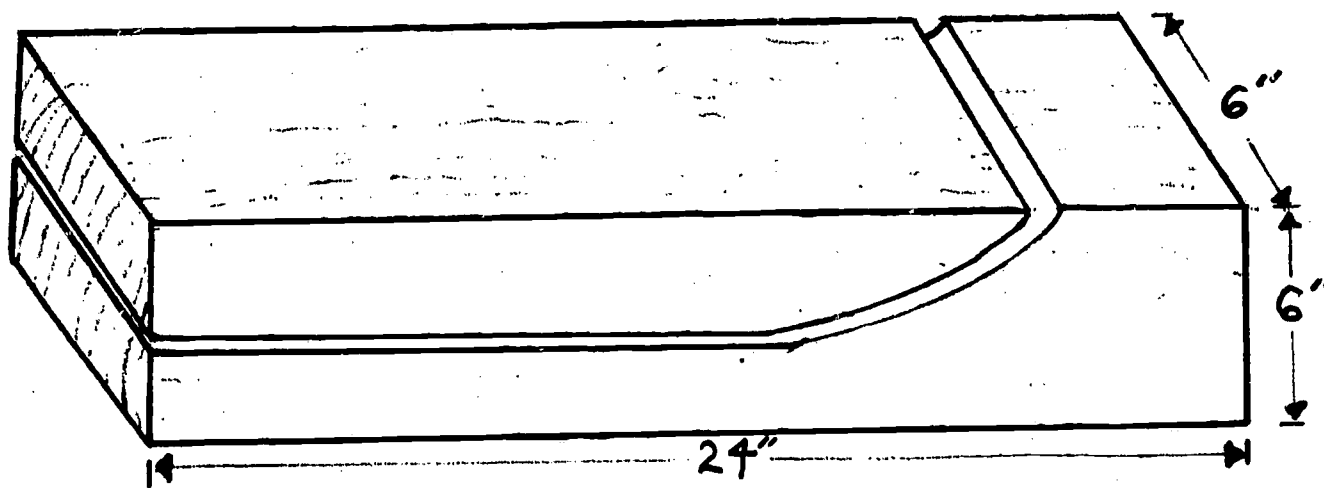

FIGURE 4

SKI CAUL

Problem: Making a flat veneer clip board (See Figure 5)

**Materials needed:**

1. Piece of hardboard, particle board or plywood 1/4" x 9" x 12" for the core of the clip board
2. Two pieces veneer 1/28" x 9 1/2" x 12 1/4" (select for their beauty and grain characteristics)
3. Two pieces plywood 3/4" x 10" x 13" for caul
4. Glue
5. Pop-rivets
6. Veneer tape
7. Any type finish desired

**Procedure:**

1. Cut veneers slightly larger than the core of the clip board. If the veneer is not wide enough, then follow these steps to joint two pieces together:
  - a. Clamp two pieces of veneer together in an edge jointing clamp. (See Figure 6)
  - b. Plane both edges at the same time until smooth and true.
  - c. Butt the two edges together and hold with veneer tape.
  - d. Fold the joint open and apply glue to edge of veneer.
  - e. Allow the glue to set properly.
2. Apply glue to face of the veneer and set it in place on the plywood core. One veneer pin in each corner will hold the veneer in place while you are sliding it into the press.
3. Repeat steps one and two to the other face.
4. Place two or three pieces of newspaper on the top and bottom to distribute the weight and prevent the veneer from becoming glued to the plywood caul.
5. Next put a caul on the top and bottom and place in the veneer press. If a veneer press is not available, use C-clamps or hand screws for pressure.
6. Machine to correct shape, sand and apply the desired finish.
7. Attach the clip with pop-rivets.

**Note:** An alternate design, for the advanced student, might include:

1. Construct lumber veneer core.
2. Five or seven ply construction.
3. Diamond match face veneer.
4. Centers of contrasting wood.
5. Borders on the face veneer.

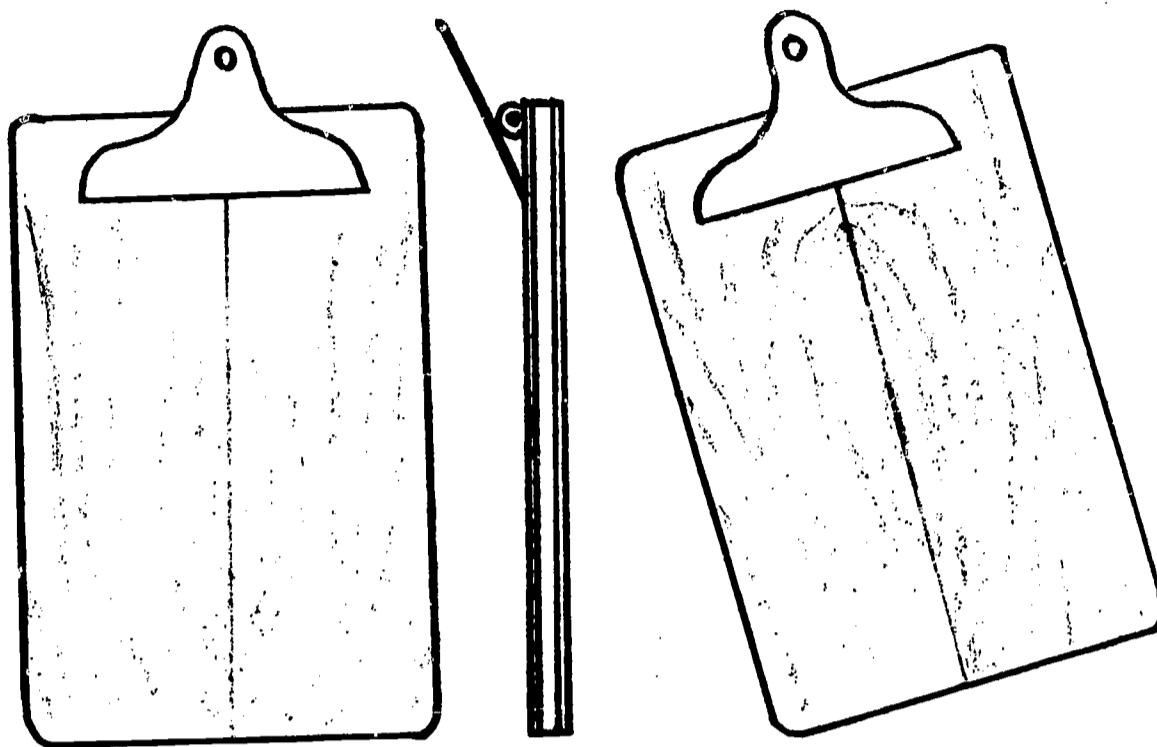

Material for Clip Board

2 pieces  $1/28''$  x  $9\ 1/4''$  x  $12\ 1/4''$  Face Veneer  
1 piece  $1/4''$  x  $9''$  x  $12''$  Plywood G<sub>2</sub>S

Material for Caul

2 pieces  $3/4''$  x  $10''$  x  $13''$  Plywood

FIGURE 5  
CLIP BOARD

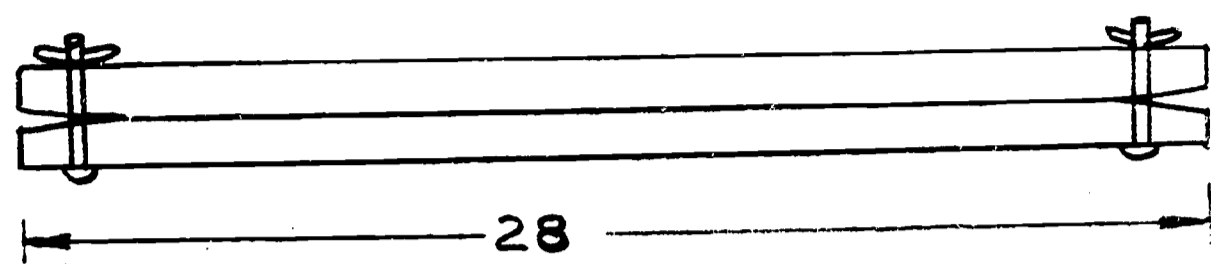

EDGE JOINTING JIG

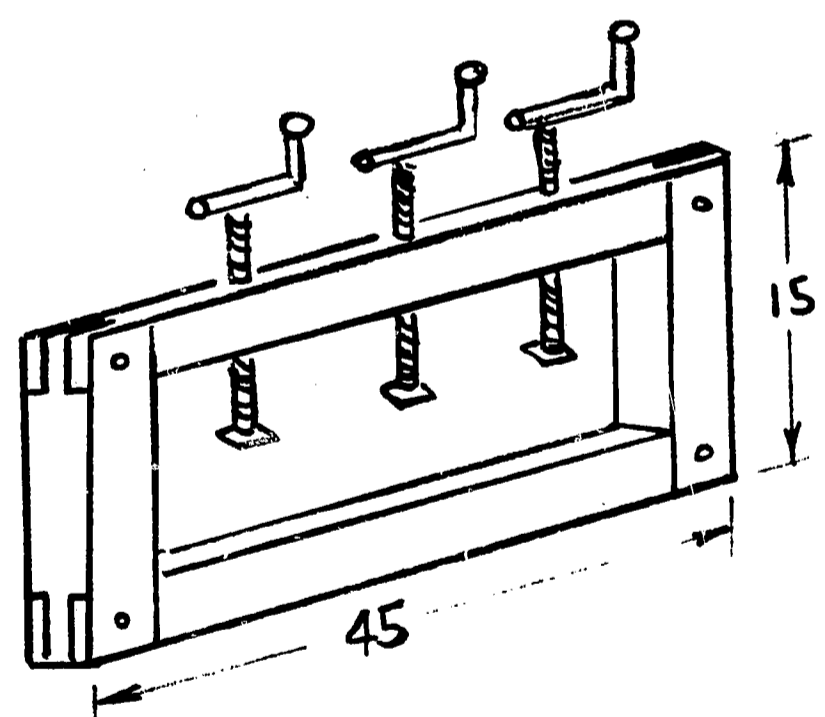
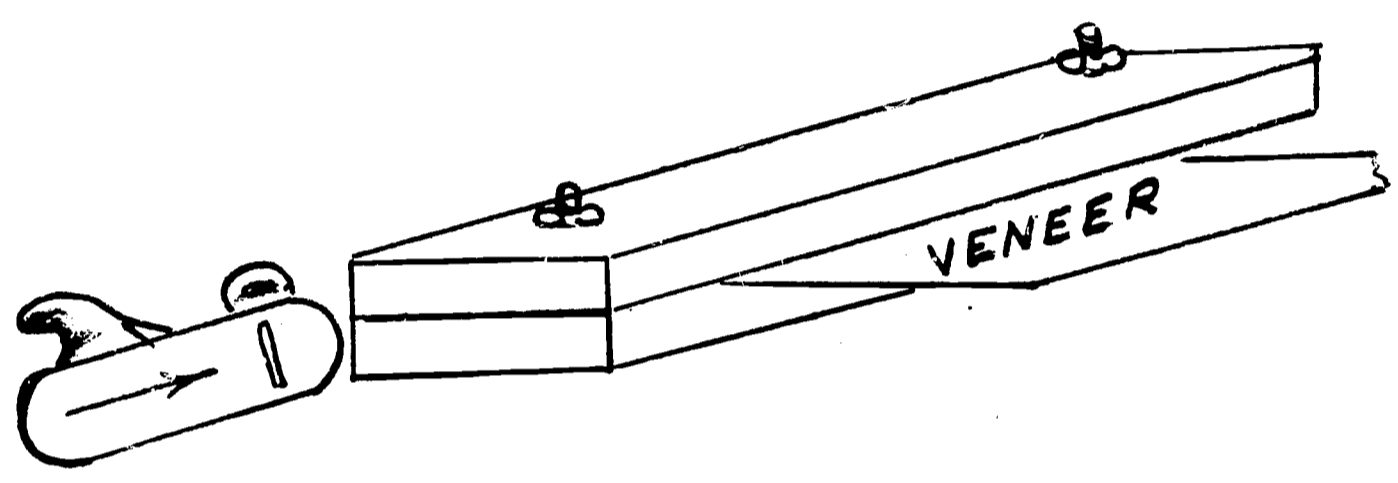

VENEER PRESS

FIGURE 6

**Problem: Making a salad server set (See Figure 7)**

**Materials needed for set:**

1. 14 pieces of veneer of contrasting colors, each  $1/28''$  x  $2\frac{1}{2}''$  x  $12\frac{1}{2}''$
2. Water resistant glue
3. Salad oil

**Procedure:**

1. Make a full size pattern of the spoon and fork.  
( $2\frac{1}{2}''$  x  $12''$  is a good size for a class project).
2. Design a caul to bend the veneers to the desired shape. You can use a piece of  $2''$  x  $4''$  stock  $12''$  long for this.
3. Cut seven pieces of veneer  $1/28''$  x  $2\frac{1}{2}''$  x  $12\frac{1}{2}''$  for the spoon and the same amount for the fork. Use contrasting colors of veneer for variety.
4. Use a small roller to apply the glue to each piece of veneer.
5. Three or four pieces of newspaper should be placed between the veneer and the caul, when you place them in the clamp, to prevent the veneer from being glued to the caul.
6. Clamp the caul together with a suitable device and allow to dry thoroughly.
7. Several types of clamps can be used: C-clamps, parallel clamps, a bench vise, or an inner tube cut into  $1\frac{1}{2}''$  strips and wound tightly around the caul will provide enough pressure to do the job.
8. Unclamp the salad server and lay out the design with the pattern.
9. Cut to shape with a jigsaw, coping saw or a band saw.
10. Smooth the piece with a spokeshave, file, scraper and sandpaper to obtain a good finish.
11. Fill the wood and apply the finish coat as in any other project. A suggestion might be several coats of salad oil.

# SALAD SERVERS

28

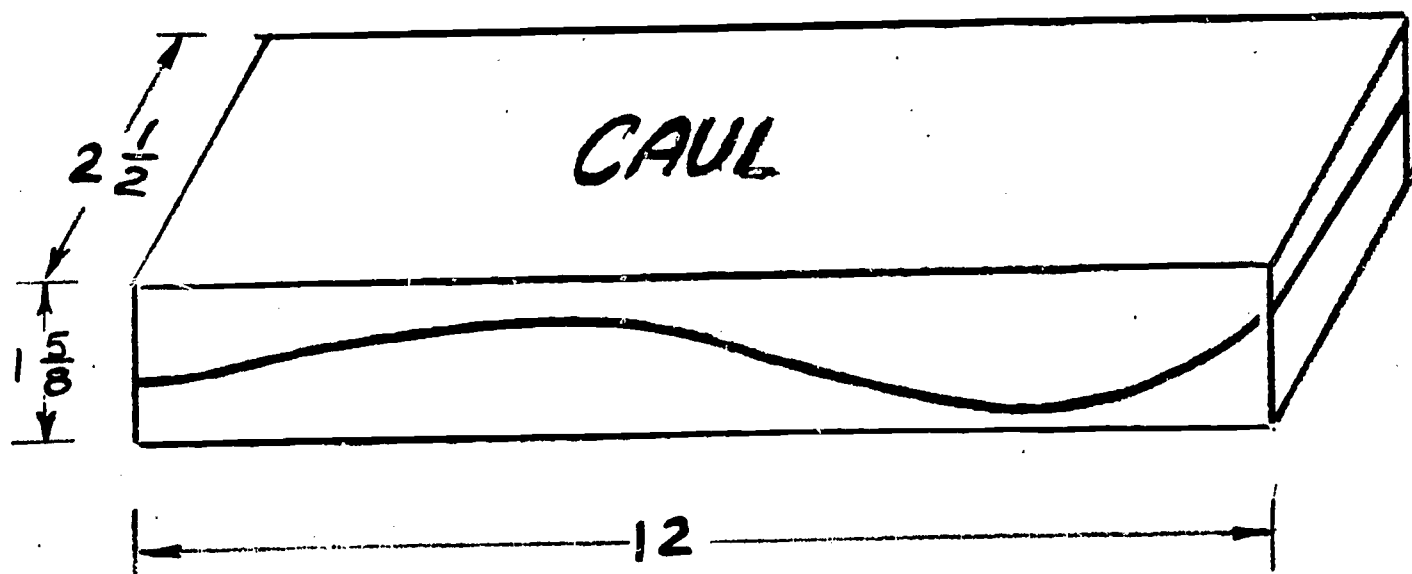
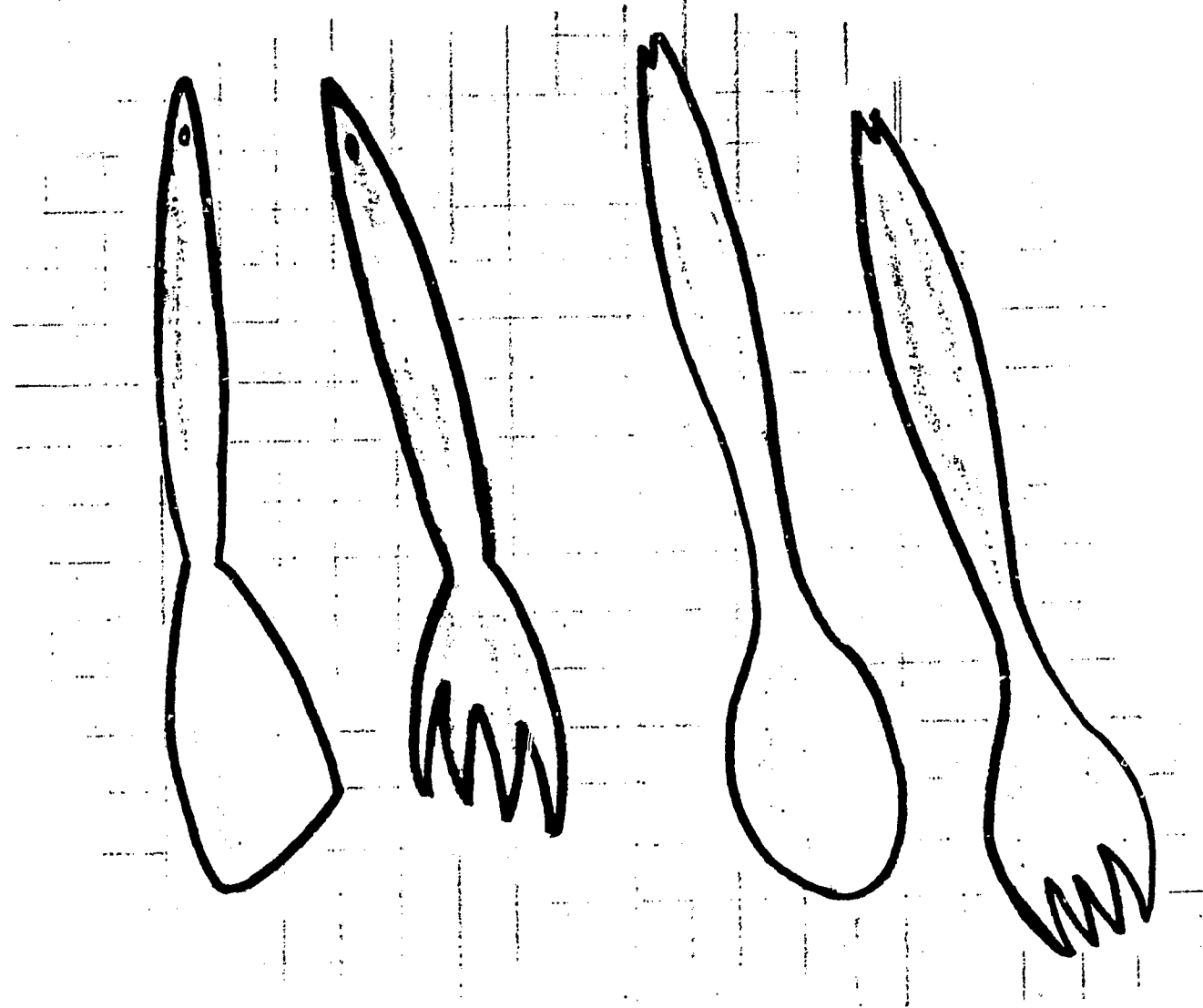

FIGURE 7

Problem: Making a bending jig

This simple bending jig can be made by Industrial Arts students for use in laminating trivets, and may be made in widths from one to two inches wide. This jig was designed to make pieces three-fourths inches wide by one-quarter inch thick by seven inches long. A two inch wide mold will allow the students to make two curved pieces at once. The curved part of the jig can be cut from any type wood to a four inch radius. If you put a rubber face on the mold it will be necessary to make the actual radius of the wood less. The piece on the bottom of the radius is three-fourths inch by two inches by eleven inches. It is mounted to the radius with screws or nails and glue. The clamp used to hold the veneer tight around the radius is made of sheet metal. The sheet metal should be the same width as the wooden form. Remove the head from a three-eighths inch by two and one-half inch bolt and weld perpendicular to a piece of three-eighths inch round steel. Drill a hole in the sheet metal, bend around the three-eighths inch steel and brad. (See Figure 8). Drill hole in bottom board so that the bolt will drop through for tightening. Bend sheet metal around jig allowing one-fourth inch or less clearance around curved part of jig. Anchor the loose end with wood screws.

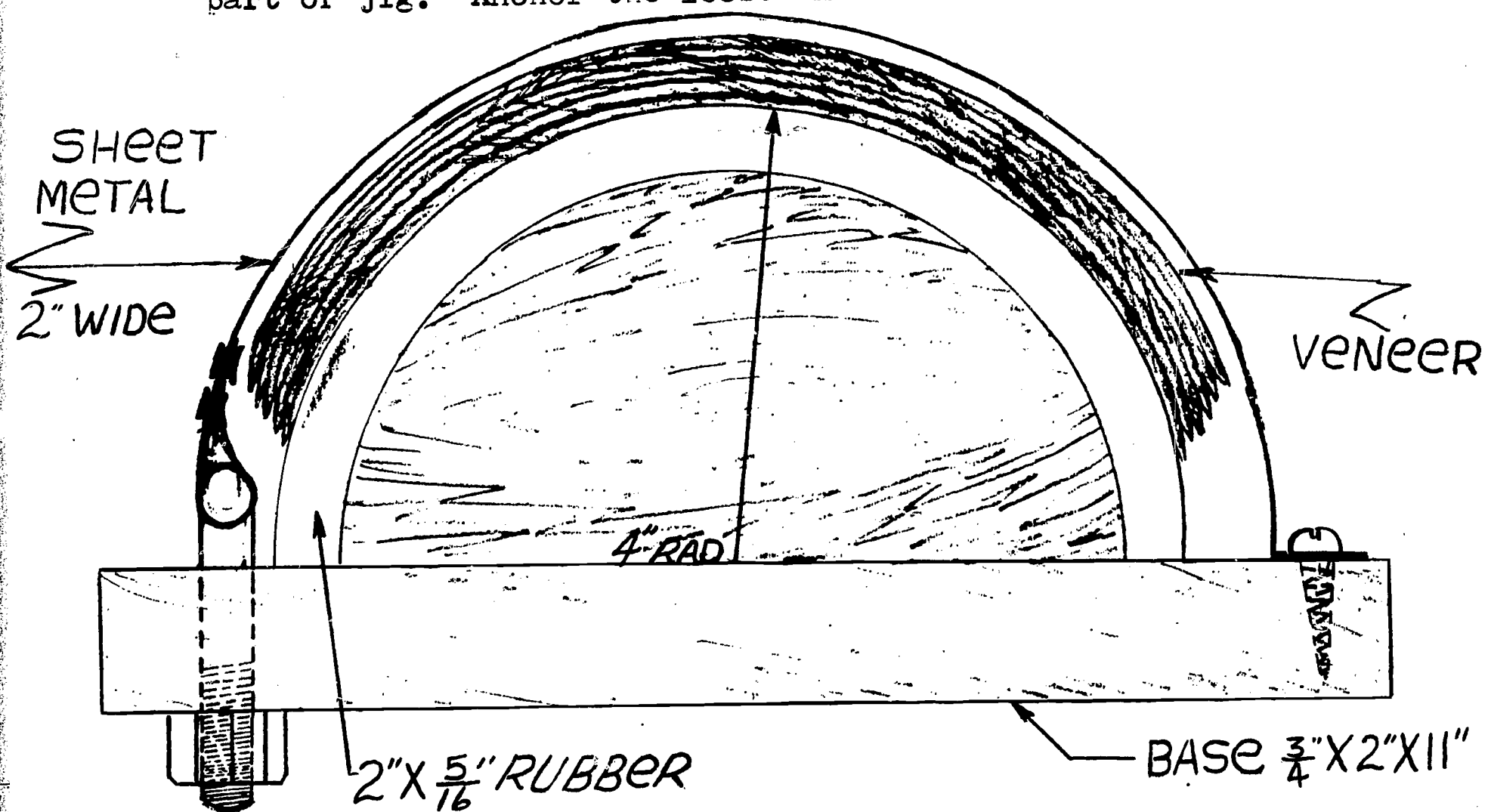

FIGURE 8

Problem: Bending with end pressure

Many failures in bending solid stock could be eliminated through the use of a metal strap with end blocks fastened firmly to it. The stock to be bent should be accurately cut to fit between the end blocks. As the piece is formed around the mold the metal strap will prevent tension breaks along the convex surface, and the blocks will exert pressure on the ends helping to achieve the compressive stress that is desired.

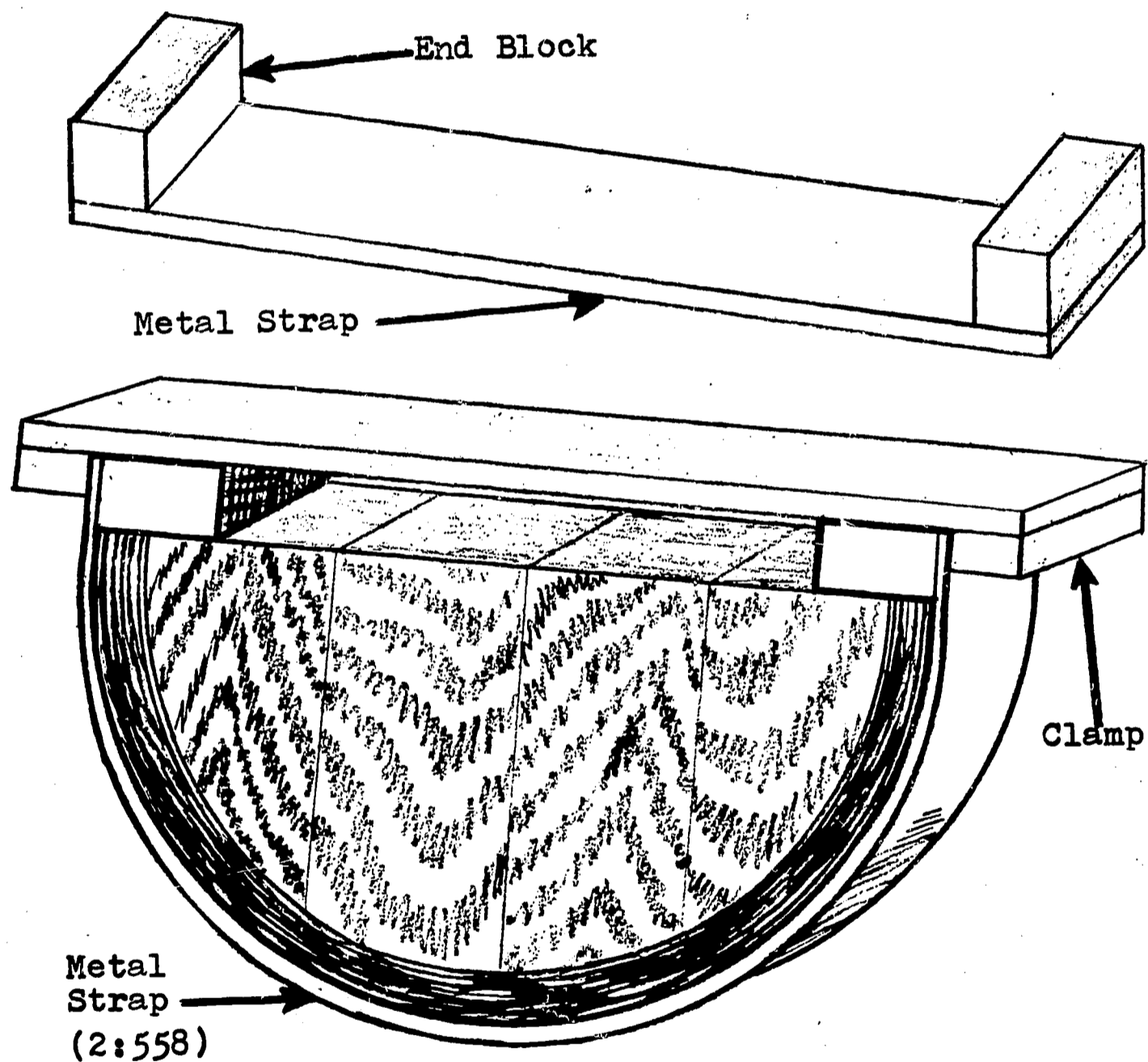

FIGURE 9

END PRESSURE CLAMP



## PLYWOOD CONSTRUCTION

- ①  $\frac{3}{4}$  PLYWOOD CAUL
- ②  $\frac{1}{28}$  FACE VENEER
- ③  $\frac{1}{4}$  CORE STOCK
- ④  $\frac{1}{28}$  BACK VENEER
- ⑤  $\frac{3}{4}$  PLYWOOD CAUL

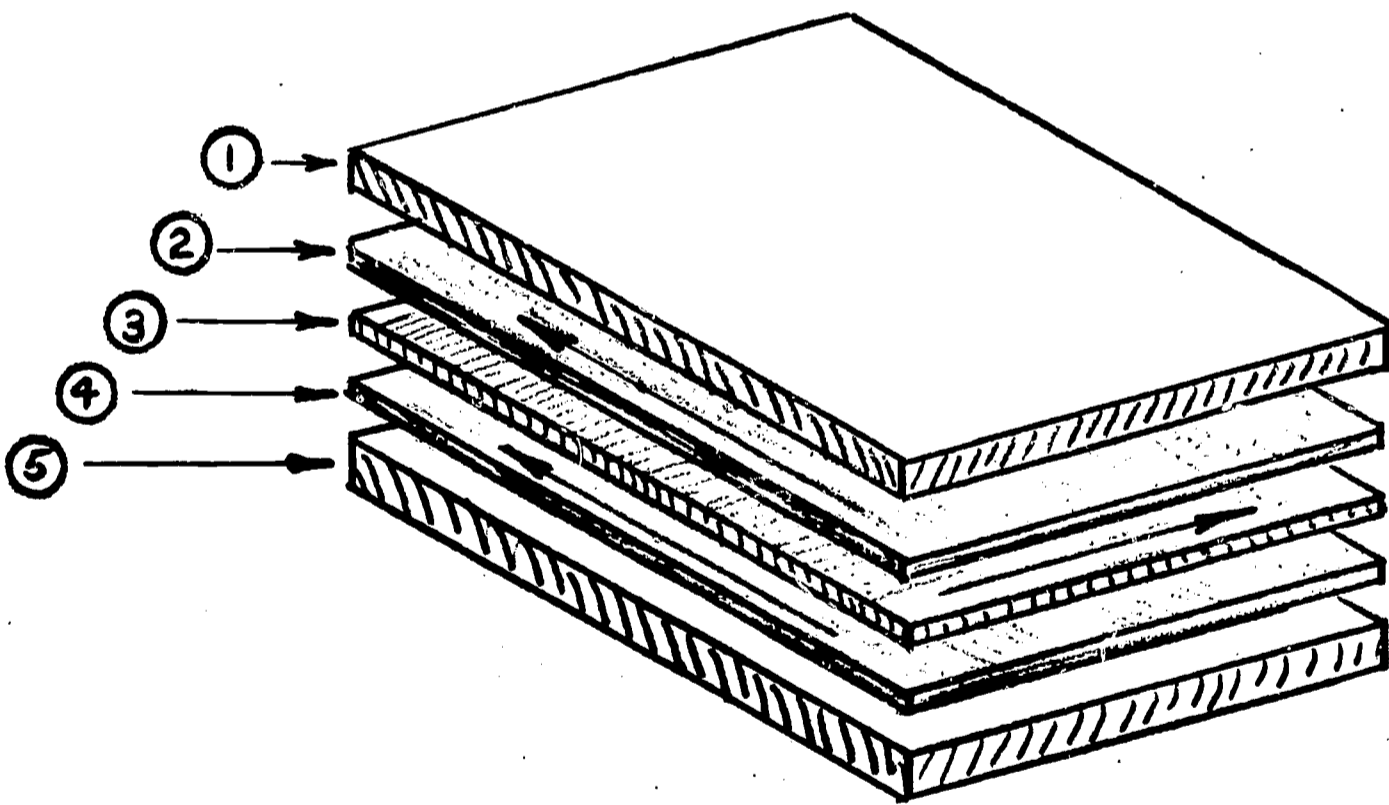

LAYERS OF VENEER MAKE PLYWOOD  
FIGURE 10

## BIBLIOGRAPHY

### A. BOOKS

1. Capron, J. Hugh. Wood Laminating. Bloomington, Illinois: McKnight & McKnight Publishing Co., 1963.
2. Feirer, John L. Cabinetmaking and Millwork. Peoria, Illinois: Chas. A. Bennett Co., Inc., 1963.
3. Feirer, John L. Woodworking for Industry. Peoria, Illinois: Chas. A. Bennett Co., Inc., 1963.
4. Hammond, James J., Edward T. Donnelly, Walter F. Harrod and Norman A. Rayner. Woodworking Technology. Bloomington, Illinois: McKnight & McKnight Publishing Co., 1967.
5. Hjorth, Herman. Veneering Made Easy. Revised by Albert Constantine Jr. New York: Albert Constantine and Son, Inc., 1961.
6. Wagner, Willis H. Modern Woodworking. Homewood, Illinois: The Goodheart-Willcox Company, Inc., 1967.

### B. PUBLICATIONS

7. Basic Information on Wood as a Material of Construction with Data for Its Use in Design and Specification, Wood Handbook, A Report Prepared by the Forest Product Laboratory Forest Service, United States Department of Agriculture, No. 72 (Washington: Government Printing Office, 1955).
8. Erickson, Richard. "Simple Bentwood Laminations," Industrial Arts and Vocational Education. November 1964, p. 69.
9. Freas, A. D. and M. L. Selbo. Fabrication and Design of Glued Laminated Wood Structural Members. United States Department of Agriculture, Technical Bulletin No. 1069. Washington: Government Printing Office, February, 1954.

10. Freas, A. D. "Factors Affecting Strength and Design of Glued Laminated Construction," United States Department of Agriculture, Report No. 2061. Madison, Wisconsin: Forest Products Laboratory, August, 1956.
11. Freas, A. D. "Laminated Timber Permits Flexibility of Design," United States Department of Agriculture, Madison, Wisconsin: Forest Service, September, 1952.
12. Peck, Edward C. Bending Solid Wood to Form. United States Department of Agriculture, Report No. 1764. Madison, Wisconsin: Forest Products Laboratory, July, 1955.
13. Selbo, M. D. and A. C. Knauss. "Wood Laminating Comes of Age," Reprinted from the Journal of the Forest Products Research Society, Vol. IV, No. 2. Madison, Wisconsin: Forest Products, 1954.
14. United States Department of Agriculture, Forest Service. "How to Make a Laminated Diving Board," Technical Note No. 244. Madison, Wisconsin: Forest Products Laboratory, 1958.

#### C. UNPUBLISHED MATERIAL

15. Rambur, William and Clarence Uri. "A Research Paper to Compare the Strength and Bending Qualities of Different Kinds of Wood and Different Plasticizing Methods." Paper Presented at San Diego State College, San Diego, California, 1966.

**PARTICLEBOARD: A TEACHING UNIT**

---

**Presented to**

**Dr. Hammer**

**Mr.. Marsters**

**Mr.. Evans**

**San Diego State College**

---

**NDEA**

**INSTITUTE IN**

**WOOD TECHNOLOGY**

---

**by**

**Eugene Aimone**

**Ervin Birzer**

**Theral Richardson**

**James Rossi**

**July 1968**

TABLE OF CONTENTS

CHAPTER	PAGE
I. PARTICLEBOARD HISTORY . . . . .	1
Definition . . . . .	1
Origin and Background . . . . .	1
II. MANUFACTURING PARTICLEBOARD . . . . .	4
Manufacturing Operations . . . . .	4
Sources of Residue . . . . .	5
Wood Particles . . . . .	5
Binders . . . . .	7
Other Additives . . . . .	10
Classification of Particleboard . . . . .	10
Flat Pressed Board Plants . . . . .	11
Extruder Board Plants . . . . .	15
III. UTILIZING PARTICLEBOARD . . . . .	17
Types and Uses . . . . .	17
Standards . . . . .	18
Core Material . . . . .	19
Fabricating & Assembly . . . . .	19
Shop Techniques . . . . .	20
Edge & Surface Treatment . . . . .	22
Recent Developments . . . . .	22
Structural Particleboard . . . . .	22
"Tri-Ply" . . . . .	22
"Mono-Ply" . . . . .	22
Exterior Particleboard . . . . .	23
Fire Retardant Particleboard . . . . .	23
IV. SUGGESTED STUDENT LAB EXPERIENCES . . . . .	24
Manufacturing Homogeneous Particleboard . . . . .	24
Chip Making . . . . .	24
Blending Chips . . . . .	24
Pre-Pressing Chips . . . . .	25
Hot-Press . . . . .	25
Manufacturing 3-Layer Particleboard . . . . .	25
Constructing A Hot Dish Trivet . . . . .	26
V. HAND-OUT SHEETS . . . . .	28
Particleboard Glossary . . . . .	28
Flow Chart . . . . .	28
Tips on Carbide Tools . . . . .	28
Particleboard Glossary Hand-out Sheet . . . . .	29
Flow Chart Hand-out Sheet . . . . .	32
The Use & Care of Tungsten Carbide Cutting Tools Hand-out Sheet . . . . .	33

CHAPTER	PAGE
VI. SUGGESTED TEACHING AIDS . . . . .	34
Flow Chart . . . . .	34
Slides . . . . .	34
Manufacturing Particleboard in The Lab . . . . .	34
Sample Board . . . . .	34
VII. MATERIALS, TOOLS & EQUIPMENT . . . . .	35
Raw Materials . . . . .	35
Chip Making Equipment . . . . .	35
Blending Equipment . . . . .	35
Hot-Press . . . . .	35
BIBLIOGRAPHY . . . . .	37

## LIST OF FIGURES

FIGURE		PAGE
1.	Hammer-Mill Hog . . . . .	6
2.	Flake Producing Machine . . . . .	6
3.	Spray Coating Blender . . . . .	9
4.	Mat Forming Machines . . . . .	12
5.	Cross Sections of Particleboard . . . . .	13
6.	Hot Dish Trivet Plan . . . . .	27
7.	Mixer . . . . .	36
8.	Fabricated Hot-Press . . . . .	36
9.	Deckle Box, Compression Block & Scale . . . . .	36

## LIST OF TABLES

TABLE		PAGE
1.	Comparisons-Five Years of Board Production . . .	3
2.	A Cross-Section of The Board Industry . . . . .	3
3.	Types and Uses . . . . .	17
4.	Minimum Properties Requirements . . . . .	18
5.	End Uses of Particleboard . . . . .	20
6.	Hot-Press Data . . . . .	25



## CHAPTER I

### PARTICLEBOARD HISTORY

With the need for flat, true surfaces being specified by designers and builders, a new engineered wood product panel has become an important factor in our economy. Modern processes and precision machinery have combined with new adhesives to create from wood particles a family of products called particleboard (4:2,3).

#### I. DEFINITION

Particleboard is defined as a generic term for a panel manufactured from lignocellulosic materials (usually wood) primarily from fibers, combined with synthetic resin or other suitable binder and bonded together under heat and pressure in a hot press by a process in which the entire inter-particle bond is created by adding the binder (5:22).

#### II. ORIGIN AND BACKGROUND

The origin of manufactured board products from wood seems to be about the same from country to country. Each begins with a workman at a sawmill or woodworking plant who feels the need for utilizing the large piles of sawdust. The man mixes some sawdust and glue and compacts the mixture into a frame of wood or canvas. After the mixture has baked in the sun, he removes the frame and rushes to the village to display his newly created wood board. This idea of manufacturing a board product from wood waste goes back over one hundred years. Insulation board and hardboard were produced from wood fibers in Europe about 1914, and in the United States in 1926. However, the production of particleboard in the United States didn't begin until about 1947 (9:30).

As of 1961, more than 2000 patents were recorded throughout the world for processes or parts of processes for manufacturing particleboard. Foremost among these were Germany, England, France, Switzerland and the United States. It wasn't until about 1930, and the advent of thermosetting synthetic resins that could be used as a binder, that wood particles were successfully converted into what is now called particleboard. It wasn't until 1941 that the first commercial particleboard was produced with phenolic resin

binder in a plant at Bremen, Germany.. The manufacture of this homogeneous single layer board was covered by Swiss patents. In 1943 and 1945, French patents were issued to Fred Fahrmi for a three-layer board using coarse particles for the middle layer and fine particles for the outer layers. Another significant step was accomplished by Otto Kreibaum at Lauenstein, Germany with the development of a continuous extrusion process in 1949. Also in 1949, the Vere Engineering Co., Limited, of London, England concluded development of a continuous flat-pressing process which produces particleboard in a continuous sheet (9:30).

The particleboard industry grew rapidly in Europe at the close of World War II. In many areas of Europe at this time, there were many destroyed forests, homes and buildings. Without usable timber, a man-made product had to be developed. Particleboard was the answer to the salvaging of broken trees, etc., and turning them into a building product to ease the shortage of marketable timber.. This successful use of timber waste was then introduced into the United States about 1947. In 1958, production in the United States was 125,000,000 square feet based on 3/4 inch particleboard.. In 1961, the production was 375,000,000 square feet, and in 1966, the industry produced nearly one billion square feet with a monetary value of \$100 million (5:4).

A look at the board industry in general shows an increase in production of board products over the past five years. The number of plants in operation or under construction in 1968 shows hardboard with 28, insulation board with 21, particleboard (mat formed) with 47, and particleboard (extruded) with 11.. The data in Tables 1 and 2 shows the three types of board being manufactured and the number of plants producing the various board product types.. Although the production of particleboard for 1967 was 1.216 billion square feet, the capacity currently stands at 1.764 billion square feet.. Production for 1968 is predicted to be 1.250 billion square feet (10:37,38).

When one thinks in terms of the cost of setting up a new plant to manufacture particleboard, there are several factors which must be considered.. The greatest single factor, in the cost of a new plant, is the use for which the board is intended.. Although it is possible to set up a small plant for \$1.5 million, most modern plants range in cost from \$2 million to \$7 million (2:1). Although particleboard plants can be designed for almost any production capacity, profitable operations usually require a daily production rate of 100-120 tons or more. Plants of smaller capacity can be profitably operated as captive plants.. That is, the entire production is utilized by a parent plant using particleboard in its manufacturing operations.. Small plants producing a sellable product from mill waste can also be operated at a profit (2:7).

TABLE 1

COMPARISONS—FIVE YEARS OF BOARD PRODUCTION

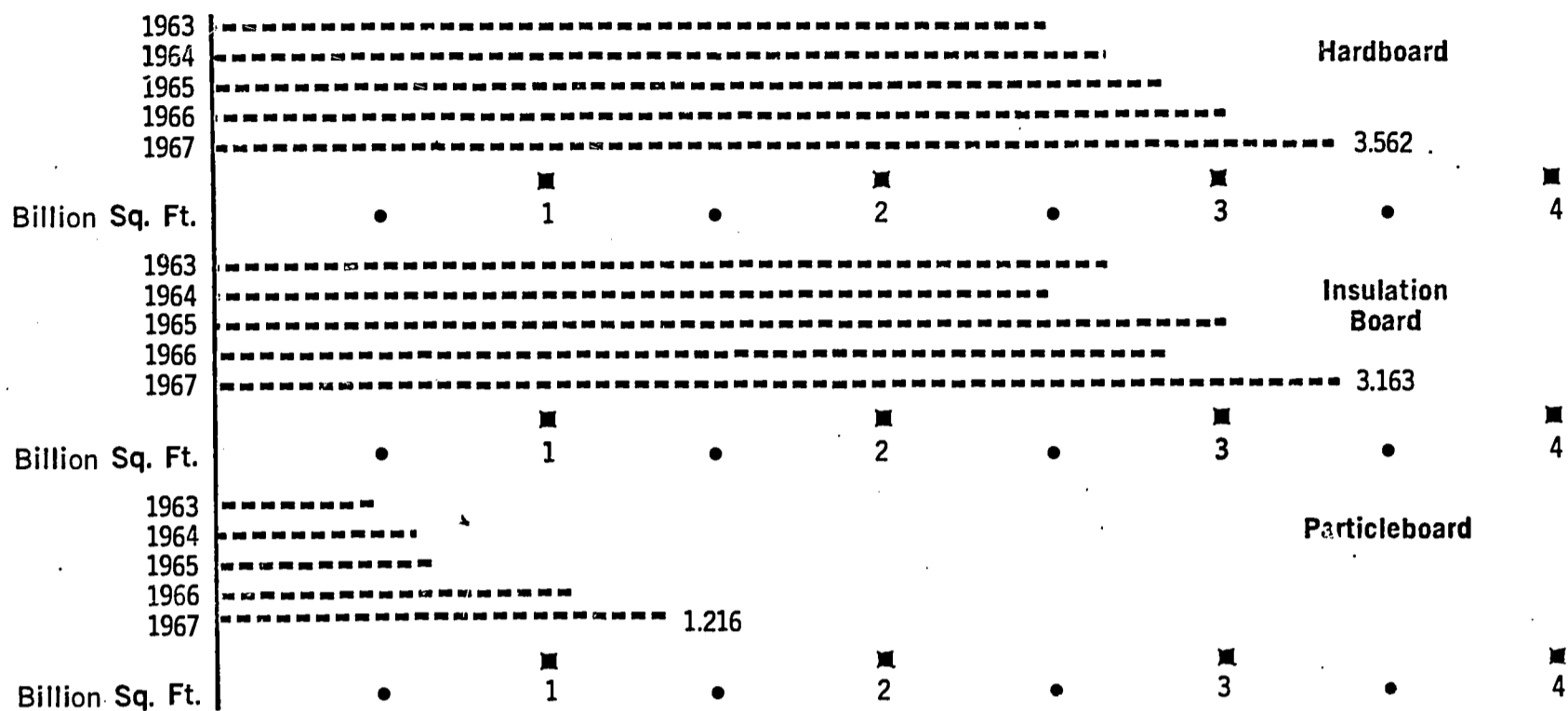

TABLE 2

A CROSS-SECTION OF THE BOARD INDUSTRY

HARDBOARD (1/8" basis) Billion sq. ft.		PARTICLEBOARD (3/4" basis) Billion sq. ft.		INSULATION BOARD (1/2" basis) Billion sq. ft.	
1963	2.46	1963	.496	1963	2.67
1964	2.72	1964	.638	1964	2.58
1965	2.94	1965	.833	1965	3.05
1966	3.18	1966	1.134	1966	2.87
1967	3.562	1967	1.216	1967	3.163

Product types	No. plants producing	Product types	No. plants producing	Product types	No. plants producing
Underlayment	20	Core	36	Decorative tile	9
Tempered	21	Furniture	22	Plain tile	8
Perforated	20	Industrial	22	Acoustical tile	8
Factory Primed	16	Cut-to-size	31	Sheathing	15
Wood grained	15	Cabinet	14	Building board	9
Prefinishing	9	Underlayment	18	Wall board	7
Plastic overlay	6	Veneer overlay	10	Industrial board	10
Veneer Core	11	Plastic overlay	8	Sound deadner	13
Garage Liner	8	Factory Primed	9	Shingle backer	8
Garage Door Panel	14	Prefinished	5	Wall plank	2
V-Grooved	9	Wood grained	3	Insulated roof deck	5
Siding	12	Floor tile	1	Factory primed	4
Overlayment	2	Siding	6	Prefinished	4
Other	7	Decking	2	Siding	5
		Door Stock	17	Formboard	2
		Other	19	Rigid roof insulation	9
				T&G	3
				Other	3

Information taken from questionnaires returned

## CHAPTER II

### MANUFACTURING PARTICLEBOARD

In the manufacture of particleboard, there are basically three processes used. One is the extrusion process which forces the resin and wax coated wood particles through a long, heated die. The second is the mat-formed process which uses a flat hot-press to form the particleboard from a mat of resin and wax coated wood particles. The third is the continuous pressing process which forms the particleboard by applying pressure through steel belts, which enclose the continuous mat of resin and wax coated wood particles, by means of steam-heated platens in the form of "caterpillar" tracks. (1:9,10). This paper will be concerned primarily with the mat-formed particleboard process using the hot-press method of forming. Except for the method of forming and/or pressing the board, many of the processes are the same or similar in the three methods of manufacturing particleboard.

#### I. MANUFACTURING OPERATIONS

The manufacturing of particleboard involves several operations. These operations include milling, drying, blending, forming, pressing and sanding. The actual processing begins with the raw materials which include wood chips, planer shavings, and/or logs. These raw materials are processed by hogs, flakers, hammer-mills, or other types of milling equipment that will produce the desired size and shape of wood particle. A system of screening is used to control particle size. Small particles are screened out and oversize particles are diverted back to the milling equipment to be remilled. Dryers are then used to reduce the moisture content of the particles to a uniform level. The particles will now be fed into a blending operation which carefully controls the amount of resin, wax, and/or other chemicals being added to the wood particles. The treated particles are then fed into a forming machine which deposits the treated particles onto belts and/or metal cauls to form mats. The amount of binder per particle and furnish per mat is controlled by weighing operations. This weighing is done automatically as the particles and mats move through the processing. The next step is pre-pressing the mats to roughly twice the finished thickness in a continuous belt pre-press. After pre-pressing, the mat will withstand the trimming operation. The mats are trimmed to a size slightly larger than the finished dimensions for the board. The mats are then loaded into a heated hydraulic press and the binders are cured and mats consolidated with temperatures up to 400° F. and pressures up

to 1000 p.s.i. After pressing, the boards are cooled and precision trimmed to the required width and length before being sanded on both sides to a thickness accurate to thousandths of an inch (5:12,13).

## II. SOURCES OF RESIDUE

In manufacturing particleboard, a wide variety of types of residue raw materials can be utilized. Some of the principal sources of this residue include the following (3:1).

1. Waste veneer, cores, and clippings from the manufacture of plywood.
2. Slabs, edgings, and trim from lumber production.
3. Green and dry planer-mill shavings from lumber production.
4. Logs of little-used species or logging residues.
5. Sawdust, shavings, and whole-wood scrap from millwork production.
6. Scrap from furniture manufacture.

## III. WOOD PARTICLES

The wood particles used in the manufacture of particleboard include: curls, flakes, fibers, granules, slivers, and strands. These particles are produced by mechanical devices such as a hammer mill as shown in Figure 1. Flakes are produced on machines with special cutters as pictured in Figure 2. Shavings usually come from planer mills producing lumber and are then reduced to uniform size in a hammer mill. Sawdust from cutting operations in sawmills are usually referred to as granules. Not much sawdust is used because of the high cost of the resin binder to cover these small, poorly shaped particles. Slivers are usually produced by hammer milling green planer shavings. The dry planer shavings produce much more fines during the hammer milling. These fines require more resin as they have much more surface area per unit of volume than do the flakes, slivers and shavings (3:3). All species of wood and any particle form could be used to make a panel material; however, some forms or kinds of wood are not used due to merchandising, manufacturing, or handling problems. Bark is a good example of this. The strength and physical properties could be maintained with the addition of sizeable quantities of bark. However, there are several reasons why bark is not used. Any of the following might be considered (3:3,4).

1. Knives of the chippers and flakers are dulled by the dirt etc. found in the bark.

FIGURE 1

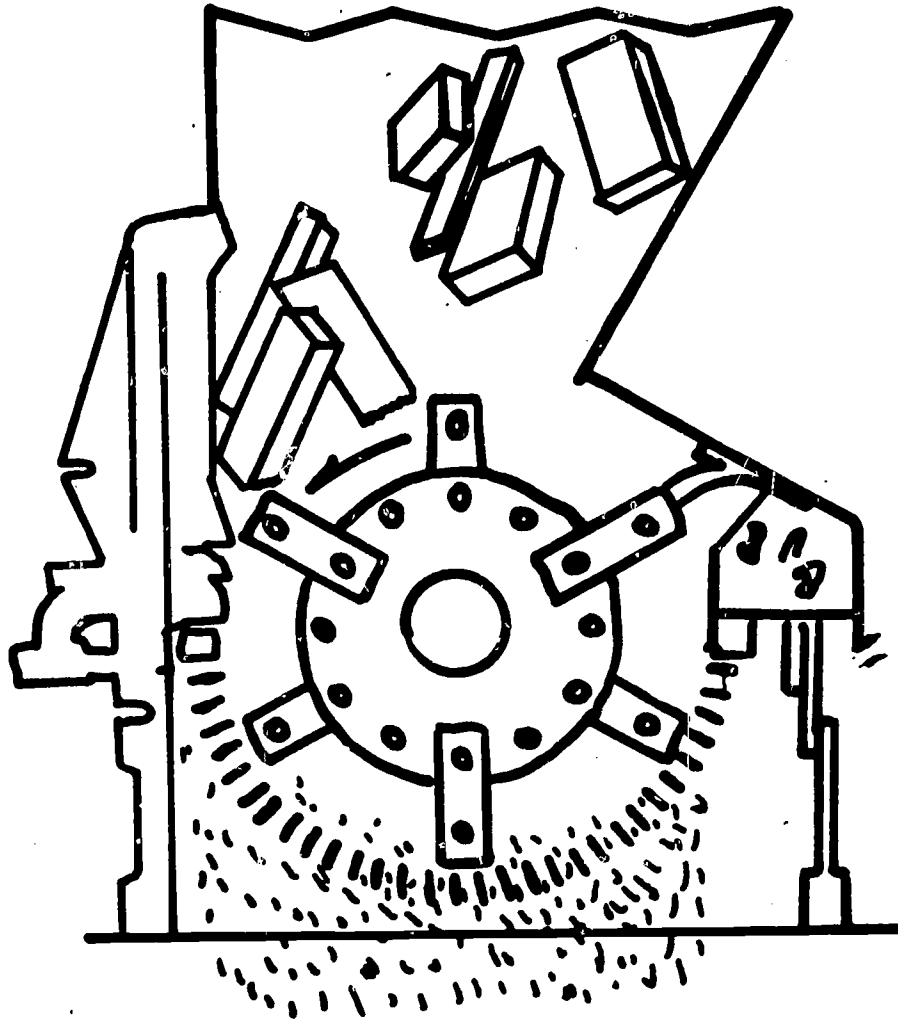

SECTIONAL VIEW OF A HAMMER-MILL HOG

FIGURE 2

CLYLINDRICAL-TYPE FLAKE PRODUCING MACHINE

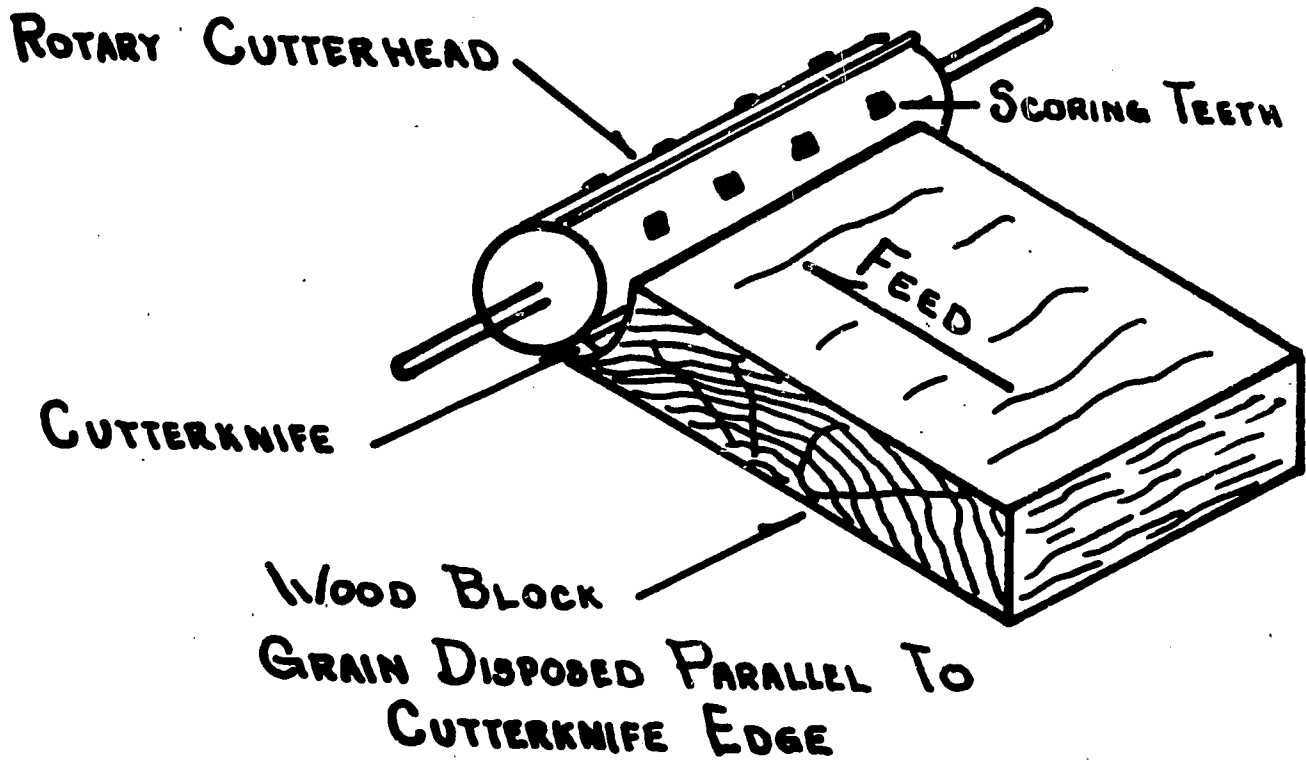

2. Screening, resin distribution, and mat formation are adversely affected by "stringy" or "flaky" pieces of bark.
3. Ratios of bark to wood are not always held constant in raw material mixtures.
4. Bark usually produces dark spots in the board, and this color is not desirable because the buyers associate quality with light color.

Hence, when whole logs are being utilized, a debarking machine or operation is employed prior to beginning the chip making process.

The size of the wood chips is controlled by any one of several screening devices. The technique is virtually the same. That is, fines are screened out and oversize chips are sent back to be remilled. The sawdust like fines tend to settle to the bottom of the board during the pressing operation. This settling will upset the uniform distribution of particle size which is so important to the production of a quality board. Fines will also weaken the board. The larger chips would create voids on the surfaces and ruin the board quality (2:3).

These chips must be uniformly dried to about 3-6% moisture content prior to receiving their coating of binder. Too low a moisture content will result in a poor bond, longer curing or press cycle, weak board, and possible warpage (2:3). The drying is usually accomplished in one of several ways. The types of dryers in use include the following: rotary drum, belt, circulation, plate or turbo, contact and suspension (1:145).

Particle geometry, the shape of the particles, is the predominate factor in determining the final strength of the manufactured particleboard. Long slivers will interlock and form a board considerably stronger than one made from sawdust type particles. The surface quality of the board is greatly improved by forming a mat with a top and bottom layer of fines in fiber form (2:3).

#### IV. BINDERS

The binders used in the production of particleboard are adhesives of one kind or another. A variety of adhesives have been experimented with. These include inorganic materials such as magnesia cements, silicates, and portland cement; and organic materials such as starch materials, proteinic substances (animal glues, blood and casein), lignin and synthetic resins. Of these substances, synthetic resins have proved to be superior as a bonding agent. Two kinds of synthetic resins are usually used. Urea-formaldehyde resins are used for the interior boards where moisture isn't a problem. The phenol-formaldehyde resins are used to bond boards for exterior use and where exposure to heat or moisture would be a factor. The following are some comparative characteristics of these two synthetic resins (1:195-197).

### Urea-Formaldehyde

Low cost (about one-half the cost of phenol-formaldehyde).

Lower curing or hardening temperature (therefore, a shorter production cycle).

Water-resistant, not water-proof.

Produces boards of lighter color (phenol darkens, when exposed, to ultra-violet rays).

Will "craze" or embrittle with age.

Will not resist boiling in water.

Will not stand tropical use or heavy weathering (high temperature and humidity).

Will wear tools faster than phenol-formaldehyde when product is being machined.

It was found that although the urea resin bond weakened little upon weathering for four months, a 12-month exposure reduced the strength by one-half.

### Phenol-Formaldehyde

Has long bonding strength and resists action of hot or cold water.

Withstands humidity cycles well (moistening-drying).

Withstands extremes of temperature and humidity.

Withstands temperatures close to the carbonization temperatures of wood. [Urea will weaken under heat treatments (140°-180° C) that may be applied to finished products to increase wood stability.]

Resists attacks of bacteria, molds, termites.

Withstands chemical action of oils, alkalis, fire-resistant and pest-resistant wood preservatives.

More resin is used in particleboard than in insulation boards and hardboard. The amount of resin per unit volume of board depends on the size and shape of the particles. Resin costs are the largest single factor in the production of particleboard. This cost amounts to about 35-60% of the total manufacturing costs. This cost can be lowered some by the proper covering of each particle with resin. Hence, the selection and use of optimum particles is of great importance. The resin is 6-10% of the dry weight of the final board. This is lower if flakes are used as these are the most efficient particles (3:8). Although the range of resin solids is usually from 6-10%, some may range from 3-12%, based on the dry weight of the board. As the resin content goes higher, the specific gravity goes higher also (1:213).

Binder costs for urea formaldehyde resin usually range from 0.75 - 1.0¢ per pound of wood used. Based on 3/4" board, at 40 lbs./cu. ft. density, the costs range from \$18.75 - \$25.00 per thousand square feet of board manufactured (2:3).

Resins may be applied in several ways. The most common method used is spraying in a liquid form. Figure 3 shows a schematic drawing of a spray-coating apparatus constructed at



FIGURE 3

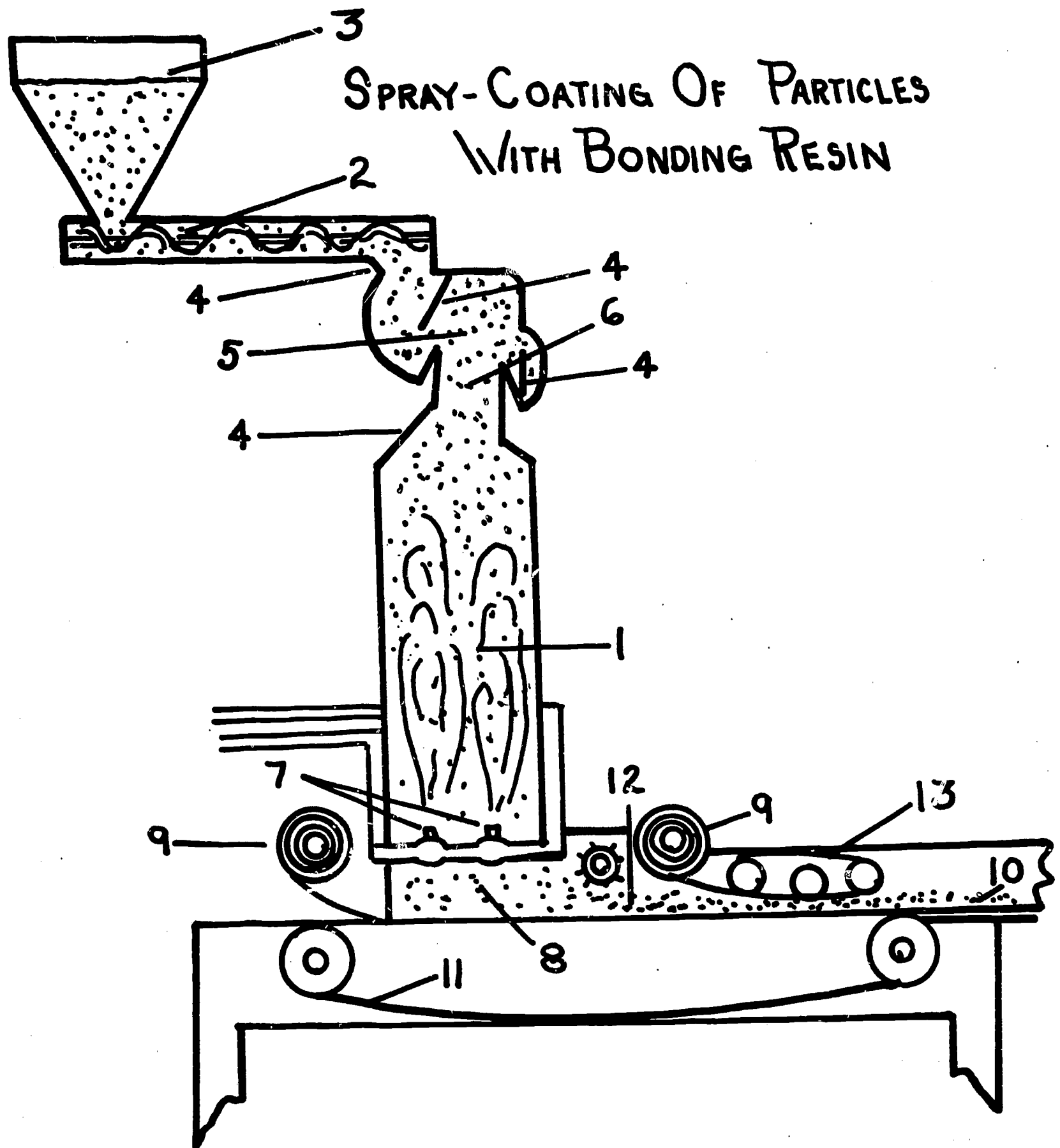

- |                                    |                                |
|------------------------------------|--------------------------------|
| 1. COATING CHAMBER                 | 7. SPRAY NOZZLES               |
| 2. WORM FEED                       | 8. CHAMBER PASS-OUT            |
| 3. HOPPER                          | 9. MAT FEED-ROLLS              |
| 4. BAFFLES                         | 10. MAT ASSEMBLY               |
| 5. AREA OF PARTICLE<br>IMPINGEMENT | 11. CONVEYOR                   |
| 6. THROAT OF COATING CHAMBER       | 12. MAT                        |
|                                    | 13. METAL BELT FOR PREPRESSING |

the Oregon Forest Products Laboratory.. The resin content of the particles is controlled by the rate of feed of the particles and the amount of resin being atomized inside the chamber.. A weighing operation is usually the controlling agent in this step of the manufacturing of the particleboard (1:160-161).

## V. OTHER ADDITIVES

Particleboard is subjected to a variety of conditions depending upon the end use of the product.. To insure resistance to fungi, water, insects, and fire, additives such as pest-repellant, water-repellants, and fire retardants are added during the blending operation.. These are then added while resin coating the wood particles (1:205-208).

As the particles are being sprayed, many times the coarse particles have very little wax and the fines are richly coated.. A concentration of well coated fines on the surface of the particleboard will cause excessive or uneven waxing. This will impede painting.. At the same time, coarse wood particles at or near the center of the board may not have enough emulsion to provide proper water resistance.. Tests show that 75% of the water absorbed during immersion of a board normally enters the core through the exposed edges.. Hence, emulsion, of the proper quality, correctly dispensed will ensure proper coverage of all wood particles.. The Mobil Oil Corporation has developed a process for controlling this important step in particleboard manufacturing.. A fluorescent dye is added to the emulsion.. After the spraying, the particles are examined under ultra-violet light.. This examination determines the degree and uniformity of emulsion deposition on the wood particles.. This quality control step can be used to determine how the system went wrong and how to correct it (6:88,89)..

## VI. CLASSIFICATION OF PARTICLEBOARD

Particleboard has been classified into nineteen separate divisions according to the method of pressing, the type of wood element, and the number of layers involved in the make-up of the panel.. This classification was completed, in a paper prepared in 1957, by George G. Marra, Head of the Wood Technology Section, Division of Industrial Research at Washington State College. The classification is given below (9:31,32).

### One Layer Boards:

1. Flat-pressed particles.
2. Extruded particles.
3. Flat-pressed mixture of particles and disintegrated flakes..

4. Extruded mixture of particles and disintegrated flakes.
5. Flat-pressed, intact flakes.
6. Flat-pressed, disintegrated flakes.
7. Extruded, disintegrated flakes.

Two Layer Boards:

1. Coarse particle base with fine particle surface.
2. Particle base with decorative flake overlay.
3. Disintegrated flake base with fine particle overlay.
4. Disintegrated flake base with decorative flake overlay.

Three Layer Boards:

1. Fibrous particle center with fibrous fine surfaces.
2. Coarse particle center with fine particle surfaces.
3. Disintegrated flakes center with fine particle surfaces.
4. Coarse particle center with disintegrated flake surfaces.
5. Coarse particle center with intact thin flake surfaces.
6. Disintegrated flake center with intact thin flake surfaces.
7. Disintegrated flakes: thick flake center with thin flake surfaces.
8. Intact flakes: Thick flake center with thin flake surfaces.

Actually, particleboard could be broadly classified into two major categories: Homogeneous and multi-layered boards. As the names imply, homogeneous boards have the same type of chip, splinter, flake, shaving or fiber throughout, and multi-layered have cores of larger wood particles with a top and bottom layer of finer wood particles. Figure 4 shows mat forming machines for homogeneous and 3-layer particleboard (2:8). Figure 5 shows a comparison of the cross sections of homogeneous, 3-layer, and extruded particleboard (2:8).

## VII. FLAT PRESSED BOARD PLANTS

The multi-platen manufacture of particleboard differs from the extrusion process in that a flat bed press of 1-20 or more openings are used depending on the press design. This size is also dependent upon the design of the machinery used in the plant. Both homogeneous and multi-layered boards can be manufactured in these plants. The plants will vary in design as follows (2:4-6):

BAHRE (BISON) SPRINGE, GERMANY

This system is designed for continuous blending of wood particles and resin and is designed to produce a

FIGURE 4  
MAT FORMING MACHINE  
HOMOGENEOUS (ONE) LAYER

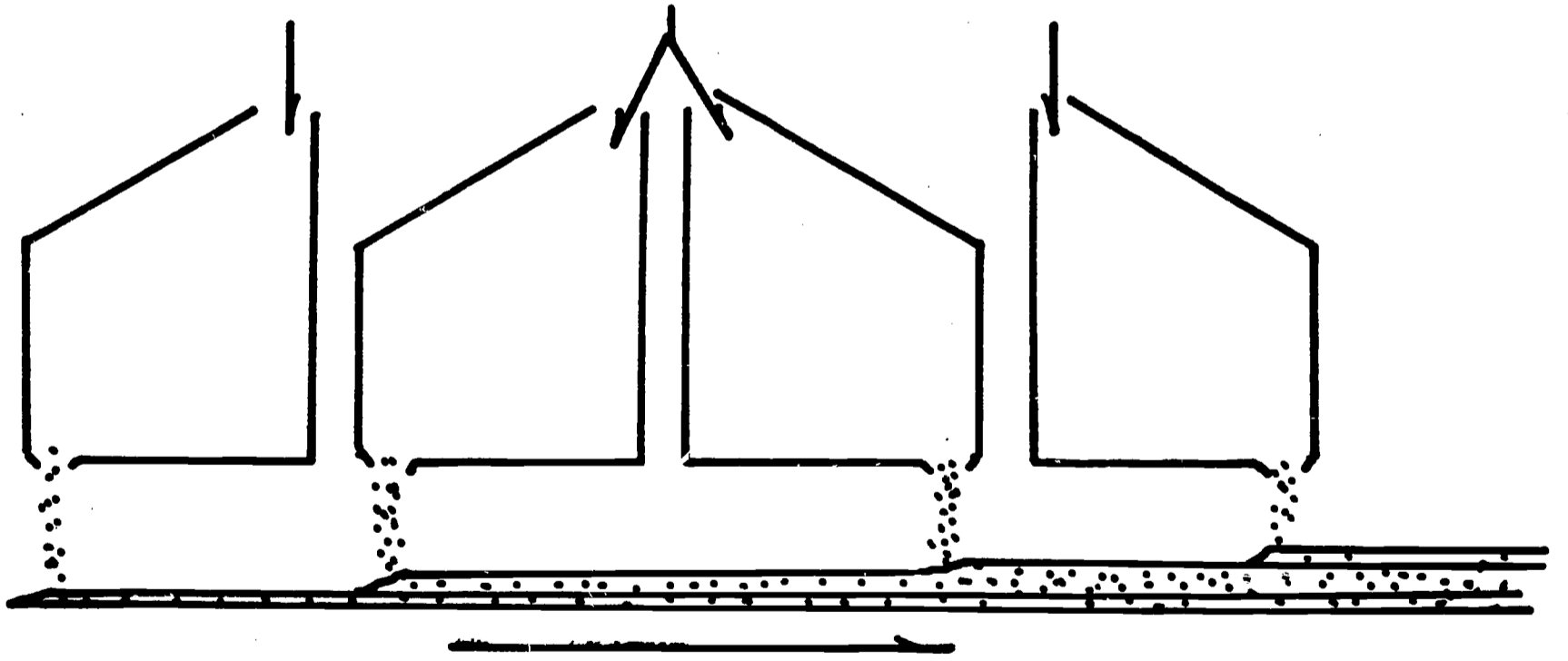
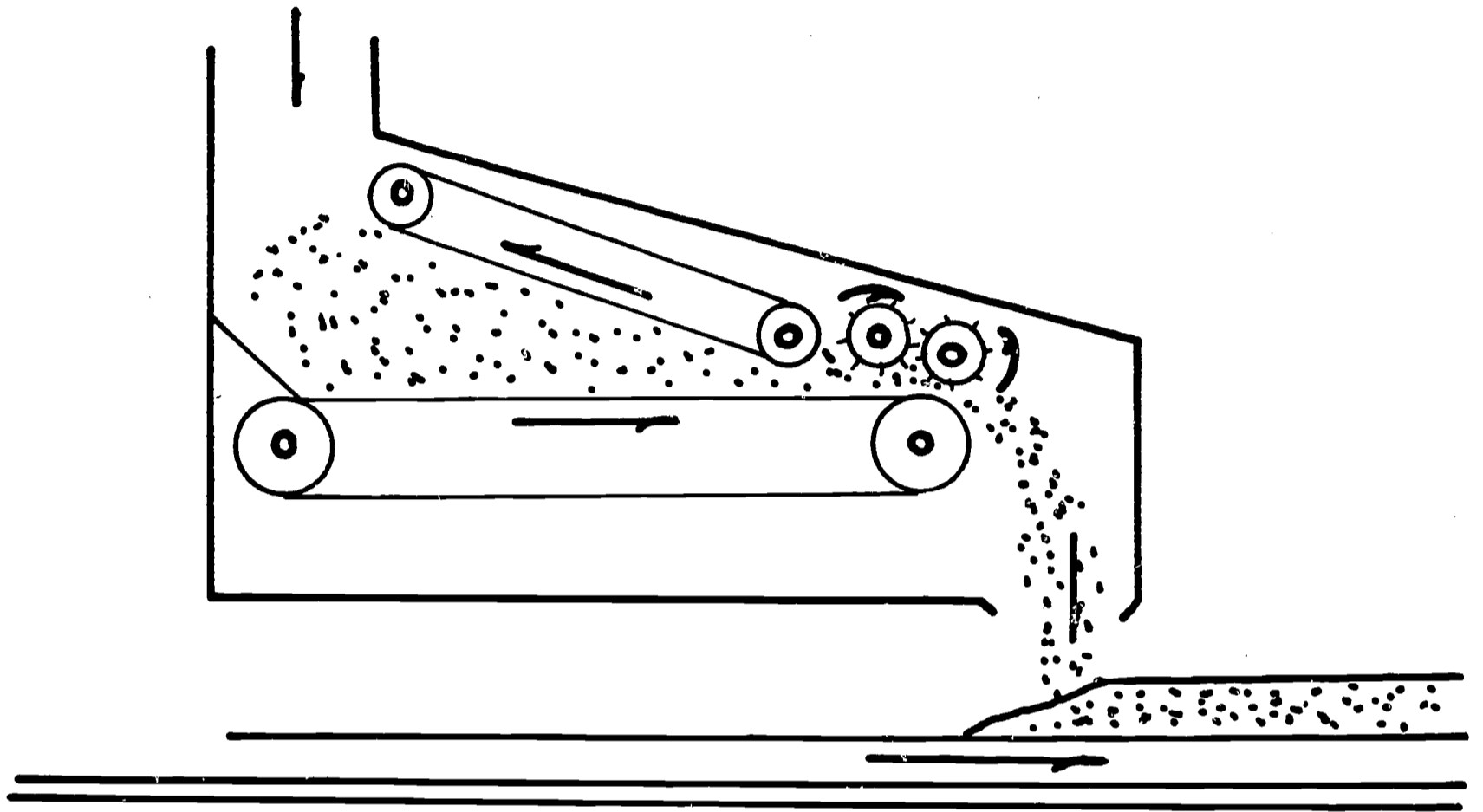

MAT FORMING MACHINE 3 LAYER BOARD

FIGURE 5

## HOMOGENEOUS BOARD CROSS SECTION

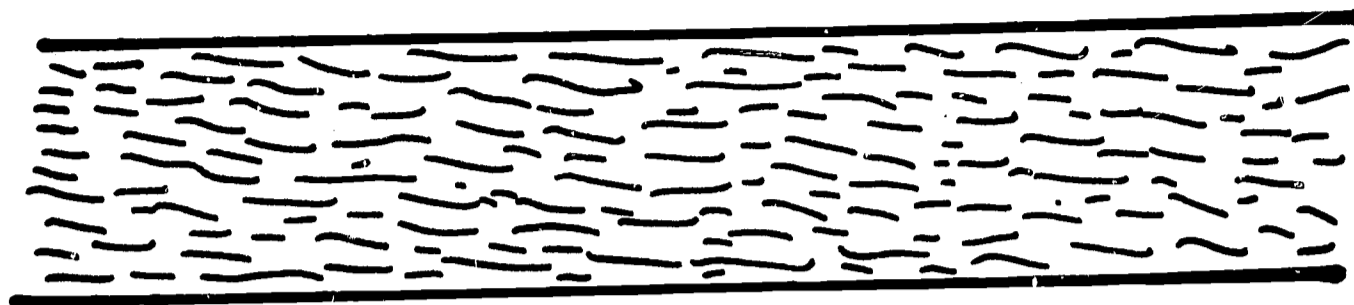

## EXTRUDED BOARD CROSS SECTION

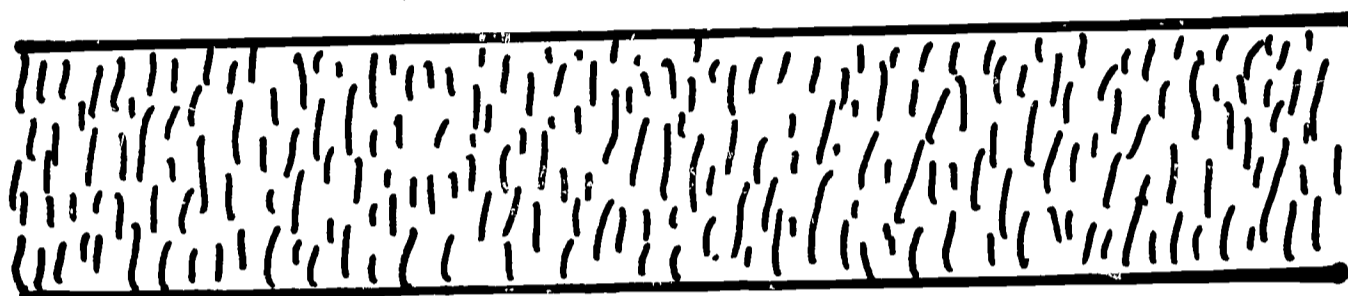

## 3 LAYER BOARD CROSS SECTION

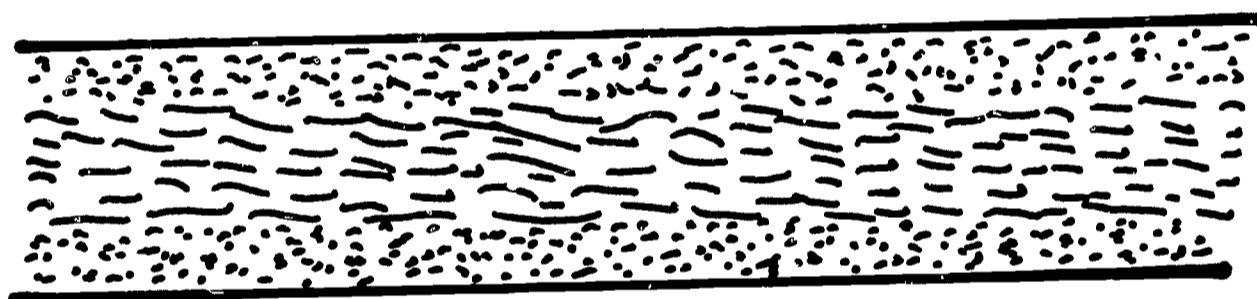

graduated board comprised of coarse particles in the core and gradually becoming finer to the surfaces. The unique feature of this system is the air felting equipment for mat formation to give the graduated board construction. Single or multi-opening presses are employed. Very short press cycles are accomplished in single opening plants by introducing moisture in form of water spray on the mat prior to pressing. Boards up to 8' x 24' can be made by this process. Multi-platen installations are becoming increasingly popular, particularly the new caulless manufacturing system. Multi-platen installations have more or less replaced the single opening Bison operations in popularity.

BEHR SYSTEM (HIMELHEBER SYSTEM), GERMANY

This process is designed to produce a 3-layered board comprised of long fibrous particles in the core and

small cubical fines and short, small diameter fibers on the surfaces. The Roddis Company (now Weyerhaeuser) has been granted sole rights in the U.S. and Canada for this process and as a result few details are available. The system is highly automated and engineered for good quality control of boards. The felting unit is reportedly comprised of a series of individual bins containing coarse fibers for the core and finer particles for the surface. The surface particles are first laid on the cauls followed by coarse core fibers, then topped with surface material. The result is a distinct 3-layered board.

COLUMBIA ENGINEERING COMPANY, NORTH VANCOUVER,  
BRITISH COLUMBIA, CANADA

The particleboard plants designed by this firm may be like the Miller-Hofft system with several innovations. Raw materials utilized are splinters, flakes and fibers (bagasse). This company also works with the Bahre Company and will engineer Bison plants both in this country and abroad.

DEMETS SYSTEM, BELGIUM

Several plants have been built in Canada and the U.S. This system is basically a 3-layered bype operation. Blenders are the Lodige type which use atomizing heads rather than spray nozzles. Wurtex formers are used with this system.

Boards are usually made from Hombak flakes or Pallman fibers depending on the system. Flakes are definitely the most popular furnish for this process.

FIBREXA SYSTEM, SWITZERLAND

This system produces homogeneous or three layer boards from splinters, flakes or shavings. The unique feature about Fibrexa plants are single RF heated presses producing extremely short press cycles.

HERMAL SYSTEM, GERMANY

Hermal System plants have been built throughout the world; at this time one plant is in production in the U.S. Caul type and caulless installations are available for manufacture of homogeneous or multi-layered board. Splinters, flakes, shavings or any type of waste from wood or other ligno-cellulose materials can be utilized.

MILLER-HOFFT, U.S.A.

This equipment is designed and installed by the Miller-Hofft Engineering Company, Richmond, Virginia and is designed to produce homogeneous splinter, flake or fiber boards. There are several plants in existence with each one being more highly automated than its predecessor. For the most part, particles are blended continuously with resin followed by mat forming usually accomplished by means of a pinwheel device that throws the coated particles forward onto

a caul as they tumble from a surge bin located above the pinwheel. The mat is then cut to length via saws, and moved along the assembly line on the caul to a loading device prior to entering the hot press for the final consolidation to ultimate board thickness.

The most modern installation utilizes wood fibers or semi-fibers, producing low, medium and high density boards. A multi-platen RF equipped press cuts press cycles extremely short.

NOVOPLY, SWITZERLAND, U.S. PLYWOOD CORPORATION-AGENT

This process yields a multi-layered board comprised of coarse splinters in the core and very thin flake-like materials on the surfaces. The U.S. Plywood Corporation is the sole licensee in this country for this procedure controlled by Fahrni Institute AG in Zurich, Switzerland. High resin treatment and high moisture content of surface flakes gives a board with an extremely hard, smooth surface which is relatively pit free.

SIEMPELKAMP AND COMPANY, KREFELD, GERMANY WILCO MACHINERY COMPANY, U.S. AGENT

This company also has world-wide experience in design of particleboard plants. Modern plants feature caulless systems producing 3-layer boards. Two types of caulless production lines have been developed, the Tray Belt System for long fibrous and flake materials which works without a prepress and the Prepress and Tray Caulless System for short fibered, granular types of material.

#### VIII. EXTRUDER BOARD PLANTS

The extrusion process differs from the multi-platen operations in that the mat forming is eliminated and the pressing operation is quite different.

Resin coated chips are fed continuously to the extrusion press which consists of two parallel heated platens, 6-18' long between which the chips are rammed at a constant rate of from 20-80" per minute. The temperature of the platens is approximately 350° F. The stroke of the ram may range from 3-5" and it may pulsate from 30-120 times per minute (2:6).

The extrusion process is economical due to the minimum labor and manufacturing costs. The full width of the board is usable with no edge trimming required. Lengths may be easily varied. Its flexural strength is low and cross-banding is required when it is used as core stock (2:6).

An extruder may be either a "vertical" or "horizontal" extruder depending on the plane of the platens. There are several types of extruder plants in operation

in the United States as follows (2:6):

CHIPCRAFT (FORMERLY MANUFACTURED AT MORRISTOWN, TENNESSEE)

This equipment is designed to produce both vertical and horizontal extruded boards. Design is quite similar to the Kreibaum unit. One outstanding feature of the vertical plant is the fact that the board is cut to lengths while in a vertical position. Pneumatic acting arms then lower the cut board into a horizontal position where it is removed from the rack and stacked in a pile.

KREIBAUM (OKAL), GERMANY (EQUIPMENT INSTALLED BY THE DEAN COMPANY, CHICAGO, ILLINOIS)

All of the plants in the United States extrude in a vertical position. One unique feature of this process is the fact that the board is bent from the vertical position to a horizontal position as it emerges from the press or heated platen area. This facilitates cutting the board to lengths by conventional saw equipment while it is in the horizontal position.

LANEWOOD (ADAMSON UNITED COMPANY, AKRON, OHIO)

All installations of this equipment are for producing horizontal extruded board and have been installed by the Adamson United Company, Akron, Ohio with the original design being done by the Lane Company, Altabista, Va. The machine speeds of this unit are somewhat faster than either chipcraft or Kreibaum equipment, being 40 to 55 inches per minute versus 30 to 36 inches per minute.



## CHAPTER III

### UTILIZING PARTICLEBOARD

There is still some reluctance, on the part of some manufacturers producing quality furniture, to using particleboard even after a decade of experience by the woodworking industry. Those who have substituted particleboard for lumber core in producing laminated panels have gained years over their competitors. They have actually improved the product without sacrificing profits. They are also accumulating vast quantities of information on the utilization of particleboard in furniture manufacturing (7:60).

#### I. TYPES AND USES

There appears to be no one piece of particleboard designed for all uses. Manufacturers are using different raw

TABLE 3

TYPES AND USES		
1. CORESTOCK	Products of flakes or particles, bonded with urea-formaldehyde or phenolic resins with various densities and related properties.	For furniture, casework, architectural paneling, doors and laminated components.
2. WOOD VENEERED PARTICLEBOARD	Corestock overlaid at the mill with various wood veneers.	For furniture, panels, wainscots, dividers, cabinets, etc.
3. OVERLAID PARTICLEBOARD	Particleboard faced with impregnated fiber sheets, hardboard or decorative plastic sheets.	For applications such as furniture, doors, wall paneling, sink tops, cabinetry and store fixtures.
4. EMBOSSSED PARTICLEBOARD	Surfaces are heavily textured in various decorative patterns by branding with heated roller.	For doors, architectural paneling, wainscots, display units and cabinet panels.
5. FILLED PARTICLEBOARD	Particleboard surface - filled and sanded ready for painting.	For painted end-products requiring firm, flat, true surfaces.
6. EXTERIOR PARTICLEBOARD	Made with phenolic resins for resistance to weathering.	For use as an exterior covering material. See FHA UM-32 or consult manufacturer.
7. TOXIC-TREATED PARTICLEBOARD	Particleboard treated with chemicals to resist insects, mold and decay producing fungi.	For tropical or other applications where wood products require protection against insect attack or decay.
8. PRIMED OR UNDERCOATED	Factory painted base coat on either filled or regular board — exterior or interior.	For any painted products.
9. FLOOR UNDERLAYMENT	Panels specifically engineered for floor underlayment.	Underlay for carpets or resilient floor coverings. See FHA UM-28.
10. FIRE-RETARDANT PARTICLEBOARD	Particles are treated with fire retardants.	For use where building codes require low flame spread material, as in some schools, office buildings, etc.

materials and manufacturing processes. A wide choice of particleboard types are available to meet the requirements of various building and fabrication situations. Particleboard is being manufactured in sizes ranging from 3/16" to 2" in thickness. Hence particleboard is truly an engineered panel.

The data in Table 3 list principal types and uses of particleboard panels (4:2).

## II. STANDARDS

The National Particleboard Association in cooperation with the Federal Housing Administration and the Department of Commerce, has established industry product standards for the production of particleboard by members of the association.

TABLE 4

Type	Density (Grade) (min. avg.)	MINIMUM PROPERTY REQUIREMENTS						
		Class	Modulus of Rupture (min. avg.) psi	Modulus of Elasticity (min. avg.) psi	Internal Bond (min. avg.) psi	Linear Expansion (max. avg.) percent	Screw Holding Face (min. avg.) lbs.	Edge (min. avg.) lbs.
	A (High Density, 50 lbs/cu ft and over)	1	2,400	350,000	200	0.55	450	—
		2	3,400	350,000	140	0.55	—	—
	B (Medium Density, between 37 and 50 lbs/cu ft)	1	1,600	250,000	70	0.35	225	160
		2	2,400	400,000	60	0.30	225	200
	C (Low Density, 37 lbs/cu ft and under)	1	800	150,000	20	0.30	125	—
		2	1,400	250,000	30	0.30	175	—
2.2	A (High Density, 50 lbs/cu ft and over)	1	2,400	350,000	125	0.55	450	—
		2	3,400	500,000	400	0.55	500	350
	B (Medium Density, Less than 50 lbs/cu ft)	1	1,800	250,000	65	0.35	225	160
		2	2,500	450,000	60	0.25	250	200

<sup>1</sup> Type 1.—Mat-formed particleboard (generally made with urea-formaldehyde resin binders) suitable interior applications.

<sup>2</sup> Type 2.—Mat-formed particleboard made with durable and highly moisture and heat resistant binders (generally phenolic resins) suitable for interior and certain exterior applications.

This is Commercial Standard CS 236-66.. Copies of the standards can be obtained by writing the National Particleboard Association. These standards represent properties necessary to assure a quality product the industries and consumers can depend upon.. In many instances, individual companies' products often test out substantially superior to the average minimums required by the standard.. The data in Table 4 shows the minimum properties which are met by the National Particleboard Association manufacturers in the production of their particleboard (4:4).

### III. CORE MATERIAL

One of the chief uses of particleboard is in the furniture industry as core material.. Particleboard is flat and has high warp resistance. It is smooth, hard and free of imperfections such as knots, cracks, and the like. Particleboard is a relatively stable board, more so than any other wood-base core material. The machinability is high and can be accomplished with any conventional woodworking equipment.. However, due to the dulling action of the resins, carbide tipped tools are recommended for production work.. Not only is it an excellent core material for use in furniture, casegoods and similar products using panel material, particleboard is also proving itself as a core or base material in architectural and home building applications (4:9). Table 5 shows lists of end uses (4:5).

### IV. FABRICATING & ASSEMBLY

Large, defect free surfaces are easily fabricated with standard woodworking tools.. Particleboard is easily sawed, routed, rabbeted, shaped and drilled.. Edges and corners remain stable during and after machining.. In machining operations, sharp tools, high speed rotation, and moderate feeds produce the best results (4:10).

The joint construction used in architectural and cabinet assemblies is readily adaptable to particleboard.. It can be butted, v-grooved, splined or covered with a decorative molding. Joint construction such as miters, splines, lock miters, dowel, mortise and tenon, dovetail and tongue and groove are easily accomplished with particleboard.. The short pieces can be utilized by butt gluing them along the void free edges (4:10).

The fastening of particleboard can be accomplished with nails, staples or screws.. When using screws, pilot holes for about 80 percent of the thread diameter is recommended.. Sheet

metal screws, Type A, and a drop of glue in the hole will also increase holding power. When using nails, 4d finish or casing nails are recommended. Glue in addition to screws or nails gives maximum joint strength (4:10).

**TABLE 5**

*Designers and users of products requiring flat panel surfaces have found particleboard ideal for scores of products in home and commercial construction. Following is a list of end uses compiled by the technical division of the National Particleboard Association.*

<b>Furniture</b>	<b>Product Design</b>	
tables (dining room, coffee, end step, dinette, library game, banquet)	toys pool tables ping pong tables game boards portable displays signs	wainscots shelving doors (solid core, sliding, bifold) partitions sink tops counter tops
buffets credenzas book cases headboards office furniture (desks, book cases, cabinets, typewriter stands, office machine tables, conference tables)	pianos organs stereo cabinets toy chests coffins dark room equipment packaging work benches and cabinets ski cores movie sets storage units printing blocks	cabinets chalkboards store fixtures floor underlayment mobile home floors drawers elevator cabs light enclosures vanitories soffits siding concrete forms radiator covers flooring mantels valances
school furniture (desks, writing tables, work tables, chairs)		
church pews chests bureaus	<b>Home and Commercial Building</b> paneling room dividers	

## V. SHOP TECHNIQUES

As with any composition board, certain techniques gradually emerge from experience in using the product under varying conditions and circumstances.

The following will prove most helpful in the shop use of particleboard (4:11).

Store particleboard and all veneers or lumber to be glued to it under identical moisture conditions; maintain moisture content below 10%. Panels should be kept in flat, even stacks in a clean, dry location, away from hot pipes and out of the direct path of heaters. Stacking sticks should be of uniform thickness, extend the full width of the material, be placed no more than 24 inches on centers, not over 6 inches from panel ends. They should be aligned vertically to prevent bowing.

Balanced laminating-If panels are intended to span wide supports the panels should be laminated on both surfaces.. To prevent warping, both surfaces of the panel should be covered with the same thickness veneer although a less expensive veneer can be used for the back.. Decorative plastic face laminates should be balanced with backing sheets as specified in NEMA Standards Publication, Laminated Thermosetting Decorative Sheets, LD1-1964.

Slots for T-molding should be cut with sharp tools which produce the correct width of slot to assure good fit of the molding.. Moldings will hold more securely if glued in place or if nailed or stapled from the underside of the panel.

Surface Gouges-Although particleboard panels leave the manufacturer's mill with an exceptionally smooth, flat surface, occasionally they are gouged, scratched or damaged in subsequent shipping or handling.. Plastic wood or wood dough will readily repair most damaged areas with one application. Deep patches should be built up in layers to avoid excessive shrinkage as the filling material dries.

Edge Filling-Considerable time and money can be saved by filling the edges of an entire stack of identical parts at one time. Fillers may be applied to the edge of a stack with a brush, rag, squeegee or by spraying.. If care is taken to leave a well filled smooth edge, only minimum sanding is required prior to final finishing.

Sawing, Drilling and Routing-High speed, carbide tipped cutting tools are recommended for large volume cutting.. Regular wood working tools produce equally good cuts but require more frequent sharpening.. Torn or ragged edges are usually the result of dull tools, eccentric arbors or lack of positive feed.. Saws, drills and routers should be checked regularly for sharpness and eccentricity. Saw arbors with more than one-half of one thousandth of an inch eccentricity will cause rough edges.. Saw teeth should be checked for alignment. Saws with teeth more than several thousandths out of line will leave ragged cuts..

Veneering and Laminating Pressures-Particle-board core panels are uniform in density and are sanded to very close tolerances. These two features permit lower pressing pressures. Excessive laminating pressures tend to exaggerate the micro variations in thickness of the various components.

## VI. EDGE & SURFACE TREATMENT

The following edge treatment methods have proved feasible with particleboard (4:13).

1. Edges can be filled and painted.
2. T-moldings give durable, attractive edge finishes.
3. Self edging with wood and/or plastic veneer.
4. Lumber edge banding which may or may not be shaped.
5. Use of edge molding commonly used with post forming.
6. High resin content particleboard can be given decorative shaped edge treatment.

Surface treatment includes coatings such as paint, enamel, stain, synthetics and lacquers. Overlays of wood veneers, high and low pressure plastic laminates, hardboard and other sheet material are also used as surface treatment.

## VII. RECENT DEVELOPMENTS

Structural Particleboard. Research work, on particleboard, has been done in the private laboratories of Elmendorf Research Inc., at Palo Alto, California. The basic aim of the project was to develop a structural particleboard by converting narrow wood flakes, called strands, into a 3-ply panel as strong as plywood. This would be several times stronger than the existing particleboard. The Elmendorf process, for orienting wood strands into parallelism, makes such a structural particleboard panel possible. This process will also enable the lumber industry to utilize most of its residues including much logging waste (12:28,30).

"Tri-Ply". Elmendorf labs have also developed a new product called "Tri-Ply". It has characteristics similar to structural particleboard (12:30).

"Tri-Ply" resembles structural particleboard in that it is a 3-ply panel with outer layers of oriented wood strands, but the center ply is made of veneer. The grain of the veneer extends across the strands of the face plies. All conventional veneer waste may be converted into strands for the face plies.

"Mono-Ply". Another of Elmendorf's product developments is "Mono-Ply" (12:30,80).

"Mono-Ply" differs in that all the strands are oriented in one direction and no veneer is used. It is best made with a thin layer of sanding dust and resin on the faces to get smooth, hard surface comparable with hardboard.

In 1/2 inch thickness with the strands in the direction of its length, and in a width of about 12 inches, a superior lap siding is produced, while 1/16 inch "Mono-Ply" can replace hardwood veneer of this thickness as the core of 1/4 inch hardwood plywood. Its manufacturing cost, where wood residues are available, will be below that of a veneer core. Its greatest strength is in one direction, as in veneer. The hardwood face veneers of plywood having a "Mono-Ply" core extend across the strands of the core.

The structural particleboard, "Tri-Ply", and the "Mono-Ply" are now ready for pilot-scale manufacture.

Exterior Particleboard. Redwood planer shavings are being used with phenolic resins to produce an "inside-outside" redwood siding and sheathing panel. This panel is roughsaw textured on one side and vee-grooved on the other. The two faces are then prime coated. At present, the panel is used to enclose single-wall construction homes being built in the Hawaiian Islands. These are being produced by Humboldt Flakeboard, Arcata, California. Humboldt also began producing a 5/8" redwood exterior siding panel for stateside consumption earlier this year (8:81).

Fire Retardant Particleboard. After several years of research, Humboldt has produced a Douglas fir particleboard which is fire retardant. This fire retardant property is accomplished by spraying a borate salt solution on the green particles just ahead of the drying operation. Underwriters' Laboratories Inc., have given it a Class 1 UL listing for thicknesses of 3/8" and over (8:81).

## CHAPTER IV

### SUGGESTED STUDENT LAB EXPERIENCES

In order to make the study of particleboard more meaningful, the students should engage in some practical lab experiences which would involve them in the manufacture and/or use of particleboard.

#### I. MANUFACTURING HOMOGENEOUS PARTICLEBOARD

After having been introduced to particleboard and its manufacturing processes, the student's experiences can be greatly enriched by actually producing homogeneous particleboard in the lab. The specimen pieces can be tested and compared with commercial products of the same type, thickness, and density.

To produce the homogeneous particleboard specimens, follow the procedure outlined below (13:8,9).

##### Chip making.

1. Cut and flue pieces of well seasoned douglas fir to form a block approximately 6" x 12" x 6".
2. Cut saw kerfs 1" deep and 1" apart and running across the grain of the stock.
3. With the jointer set for 1/16" cut, joint the stock across grain parallel with the saw kerfs. Check the chip size. It should be approximately 1" x .010" to .015" in random widths. Adjust the jointer if necessary.
4. Continue jointing and catch chips. Cut additional kerfs as necessary. Continue chipping as long as you have a safe size block for jointing.

##### Blending chips.

1. Weigh two pounds or more of chips and place them in the mixer.
2. Weigh a quantity of binder (liquid urea formaldehyde) equal to 10% of the amount of chips. NOTE: If the urea resin is not 100% solids, weigh enough additional resin to equal the weight of 100% solids. That is, if the resin is 50% solids, weigh enough resin to equal 20% of the chip weight. This will equal 10% chip weight at 100% solids.
3. Thin with water to spraying consistency if necessary and load the spray gun.



4. Start the mixer and spray all the resin onto the chips through a hole in the center of the mixer cover.

#### Pre-pressing chips.

1. Select the thickness of the particleboard specimen to be produced and compute the number of cubic inches in the finished piece.

2. Weigh 12 grams of resin coated chips for each cubic inch of particleboard specimen.

3. Distribute the chips evenly into a deckle box. (See Chapter 7)

4. Place a compression block in the deckle box and pre-press cold to  $1\frac{1}{2}$  to 2 times final thickness. Use a vise or other clamping methods to apply pressure.

#### Hot-press.

1. Heat press platens to  $300^{\circ}$  F.

2. Remove mat from the deckle box and place it carefully between the platens.

3. Place metal thickness stops beside the mat on the bottom platen.

4. Apply pressure to compress the platens and mat to the thickness stops.

5. Release excess pressure, but keep platens touching the thickness stops until the resin cures. See Table 6 (13:7).

6. Release pressure and remove sample. CAUTION: Press platens and specimen will be hot. Handle carefully with welding gloves.

TABLE 6

Sample Thickness	Platen Temp.	Cure Time
$1/4''$	$300^{\circ}$ F	$1\frac{1}{2}$ min.
$3/8''$	$300^{\circ}$ F	3 min.
$1/2''$	$300^{\circ}$ F	5 min.
$3/4''$	$300^{\circ}$ F	8 min.

## II. MANUFACTURING 3-LAYER PARTICLEBOARD

When the student has completed the lab manufacturing of homogeneous particleboard, the manufacturing of 3-layer board will give further insight into the industrial processes involved in particleboard manufacturing. These specimens can

be compared with the homogeneous board. The student might also be asked to develop a project using these lab made specimens.

To make 3-layer board, produce chips as for homogeneous boards. Screen these chips through a 1/8" square wire mesh screen. Keep the fines separate from the coarse chips. The outer layers should be 1/8" thick and consist of 12 grams of resin coated particles per cubic inch of thickness. Coat the fines with liquid urea resin equal to 15% of the chip weight. This is also based on 100% solids for the resin. The coarse chips, for the core layer, should be 17 grams per cubic inch of thickness with 10% resin by weight. Carefully weigh the fines for each outer layer and distribute one layer evenly in the bottom of the deckle box. Follow this with the weighed chips for the core layer. Distribute the other layer chips carefully into the box. Pre-press and hot-press time and temperatures will follow the data in Table 6. This procedure has been experimented with and produces good quality 3-layer boards.

### III. CONSTRUCTING A HOT DISH TRIVET

The construction of the hot dish trivet will give the student first hand experiences in working with particleboard. The regular woodworking tools, both hand and power, can be utilized in its construction. The plan for the trivet, as shown in Figure 6, could be duplicated and used as a hand-out. Likewise, the plan of procedure could be used as a hand-out. The following is a suggested plan of procedure for constructing the trivet.

1. Cut a piece of one-half inch particleboard to rough size of approximately seven by seven inches.
2. Select a piece of high pressure laminate plastic to cover the piece of particleboard.
3. Bond the plastic to the particleboard with contact cement. Following manufacturer's instruction carefully.
4. Layout the full size design on the plastic surface using a pencil, rule, compass and 30-60 triangle.
5. Drill 3/4" and 1" holes using low speed and a multi-spur bit.
6. With plastic face up, saw slightly outside layout lines with a fine-toothed jig saw or band saw.
7. Sand all sides to layout lines.
8. Bevel plastic edges slightly with a smooth mill file.
9. Apply a coat of clear finish to all exposed surfaces of the particleboard.
10. Drive rubber bumper tacks near the three corners on the bottom face of the trivet.

FIGURE 6

## TRIVET FOR HOT DISHES

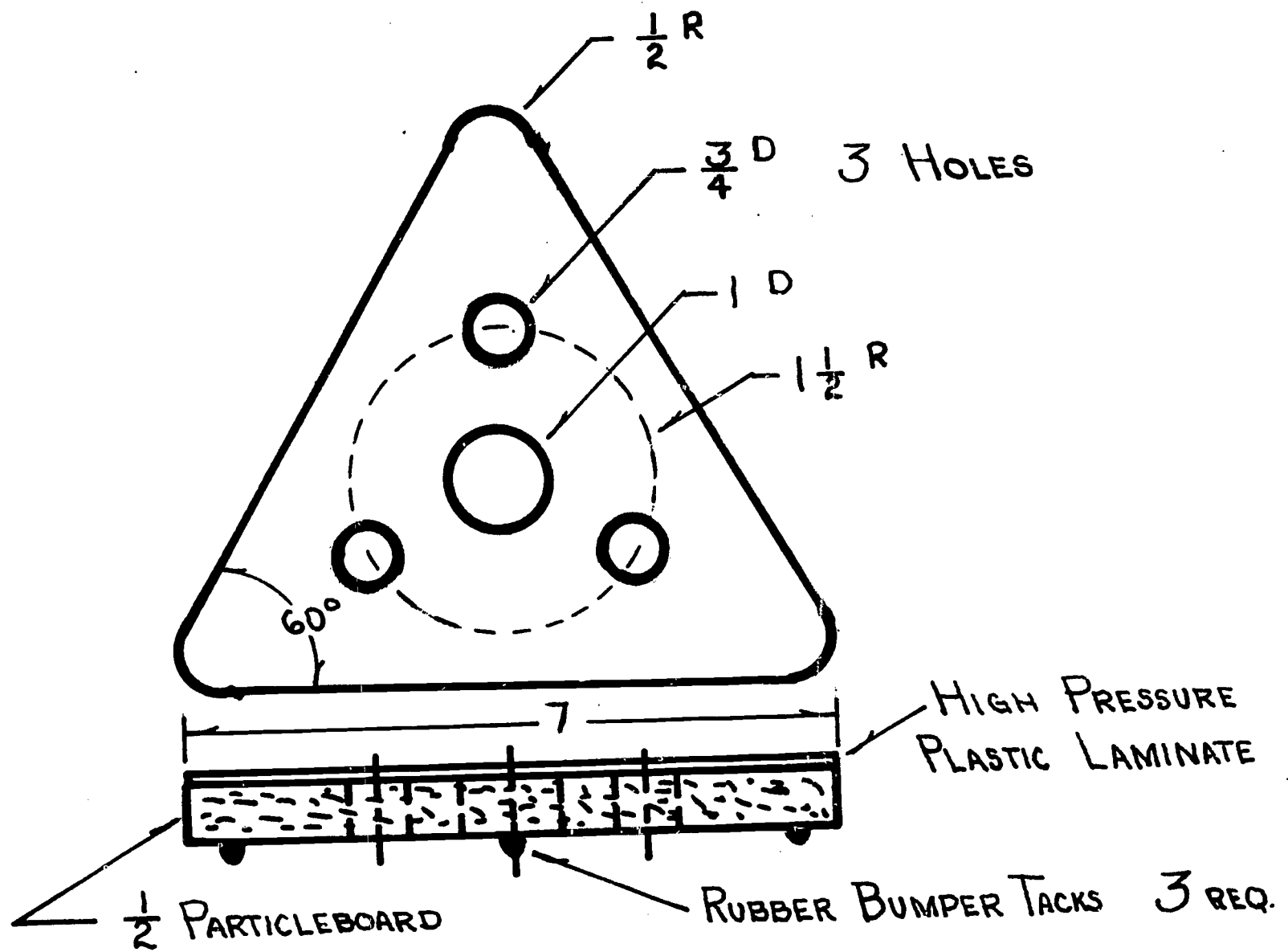

BASIC DESIGN MAY BE MODIFIED TO ALTERNATE SHAPES SUCH AS DIAMOND, SQUARE, RECTANGULAR OR CIRCULAR.

## CHAPTER V

### HAND-OUT SHEETS

A brief description of each hand-out sheet will be given. The sample hand-out sheets will follow the descriptions.

#### I. PARTICLEBOARD GLOSSARY

There are always some special words and phrases pertinent to the study of a specific field or area. Hence, a glossary of terms for particleboard would be among the first items used as a hand-out sheet.

#### II. FLOW CHART

The flow chart describing the processes involved in the manufacturing of particleboard can be reproduced as a hand-out to aid in the discussion, lecture and/or independent study of particleboard.

#### III. TIPS ON CARBIDE TOOLS

In view of the fact that particleboard dulls ordinary cutting tools quickly, carbide or carbide tipped tools are recommended for sawing, shaping and drilling operations. The hand-out on carbide tools would be appropriate at this time.

## PARTICLEBOARD GLOSSARY

**AIR FELTING:** Forming of fibrous-felted board from air suspension of damp or dry fibers on a batch or continuous forming machine (sometimes referred to as the dry or semi-dry process).

**BINDER:** Extraneous bonding agent, either organic or inorganic, used to bind particles together to produce particleboard.

**CAULS:** Metal sheets which support the mat of particles before pressing..

**CHIPS:** Small pieces of wood chopped off a block by ax-like cuts as in a chipper, or produced by mechanical hogs, hammer-mills, etc.

**CURLS:** Long, flat flakes manufactured by the cutting action of a knife in such a way that they tend to be in the form of a helix.

**DENSITY:** A measure of the weight of a material for a specific volume of the material. Usually expressed as pounds per cubic foot.

**DIE:** Metal tool with top and bottom which converge toward out-feed end of die, thereby exerting pressure against material being forced through die..

**DRY FORMED:** Process in which particles are formed into a mat in a dry state rather than from a water slurry.

**EXTRUDED PARTICLEBOARD:** A particleboard manufactured by forcing a mass of particles coated with a binder through a heated die with the applied pressure parallel to the faces and in the direction of extruding..

**FILLED PARTICLEBOARDS:** Particleboards having a factory applied coating of filler on one or both faces to prepare the surface for further finishing by printing, lacquering, painting, etc.

**FINES:** Small particles of wood, generally of such a size they will pass through a 20-mesh screen..

**FLAKE:** Small wood particle of predetermined dimensions specifically produced as a primary function of specialized equipment of various types, with the cutting action across the direction of the grain (either radially, tangentially, or at an angle between), the action producing a particle of uniform thickness, essentially flat, and having the fiber direction essentially in the plane of the flakes.

**FURNISH:** Flakes that have been impregnated with resin and/or wax.

**FLAT-PLATEN PRESSED:** A method of consolidating and hot pressing a panel product in which the applied pressure is perpendicular to the faces.

**HAMMER MILLING:** A form of grinding in which pieces of material are reduced in size by the action of hammers or knives mounted on a rapidly rotating shaft in the machine.

**HOMOGENEOUS BOARDS:** Particleboards having a uniform mixture of particle sizes throughout.

**HOT-PRESSING:** Process for increasing the density of a wet-felted or air-felted mat of fibers, or particles by pressing the dried, damp, or wet mat between platens of hot-press to compact and set the structure.

**MOE:** Modulus of elasticity. A measure of flexural strength. Modulus of elasticity represents rigidity or stiffness.

**MOR:** Modulus of rupture. A measure of flexural strength. Modulus of rupture is the maximum load at which failure occurs.

**MULTI-LAYERED BOARDS:** Particleboards having particles of different sizes or shapes in different areas of their cross section. Commonly fine particles or very thin flakes are used on the surfaces of the boards to provide a high degree of smoothness.

**OVERLAID PARTICLEBOARDS:** Particleboards having factory applied overlays which may be resin treated papers, high or low pressure decorative plastic laminated, plastic films, hardboard, hardwood veneers, etc..

**PARTICLE:** Aggregate component of particleboard manufactured by mechanical means from wood or other lignocellulosic material, including all small subdivisions of wood such as chips, curls, flakes, sawdust, shavings, slivers, strands, wood flour, and wood wool. Particle size may be measured by screen mesh that permits passage of particles and another screen upon which they are retained, or by the measured dimensions as for flakes and strands.

**PARTICLEBOARD:** A generic term for a panel manufactured from lignocellulosic materials (usually wood) primarily in the form of discrete pieces or particles, as distinguished from fibers, combined with a synthetic resin or other suitable binder and bonded together under heat and pressure in a hot-press by a process in which the entire inter-particle bond is created by the added binder.

**PLANER MILL SHAVINGS:** Shavings produced in lumber planing mills.

**PLATENS:** The flat plates in the hot-press which compress the mats into particleboards.

**RESIN:** Synthetic binder material used to bond wood particles together to form particleboards.

**SAWDUST:** Wood particles resulting from the cutting and breaking action of saw teeth.

**SHAVING:** A small wood particle of indefinite dimensions which develops during certain woodworking operations involving rotary cutterheads usually turning in the direction of the grain; particle is usually feathered along at least one edge and thick at another and usually curled.

**SIZE:** Asphalt, rosin, wax, or other additives introduced to the stock for a fibrous-felted board, prior to forming, or added to the blend of particles and resin for a particleboard to increase water resistance.

**SLIVERS:** Particles of nearly square or rectangular cross-section with a length parallel to the grain of the wood of at least four times the thickness.

**STRAND:** A relatively long (with respect to thickness and width) shaving consisting of flat, long bundles of fibers having parallel surfaces.

**TEMPERING:** The manufacturing process of adding to a fiber or particle panel material a siccative material such as drying oil blends of oxidizing resin which are stabilized by baking or by other heating after introduction.

**WOOD FLOUR:** Very fine wood particles generated from wood reduced by a ball or similar mill until it resembles wheat flour in appearance, and of such a size that the particles usually will pass through a 40-mesh screen.

**WOOD WOOL (EXCELSIOR):** Long, curly, slender strands of wood used as an aggregate component for some particleboards.

# MANUFACTURING PARTICLEBOARD

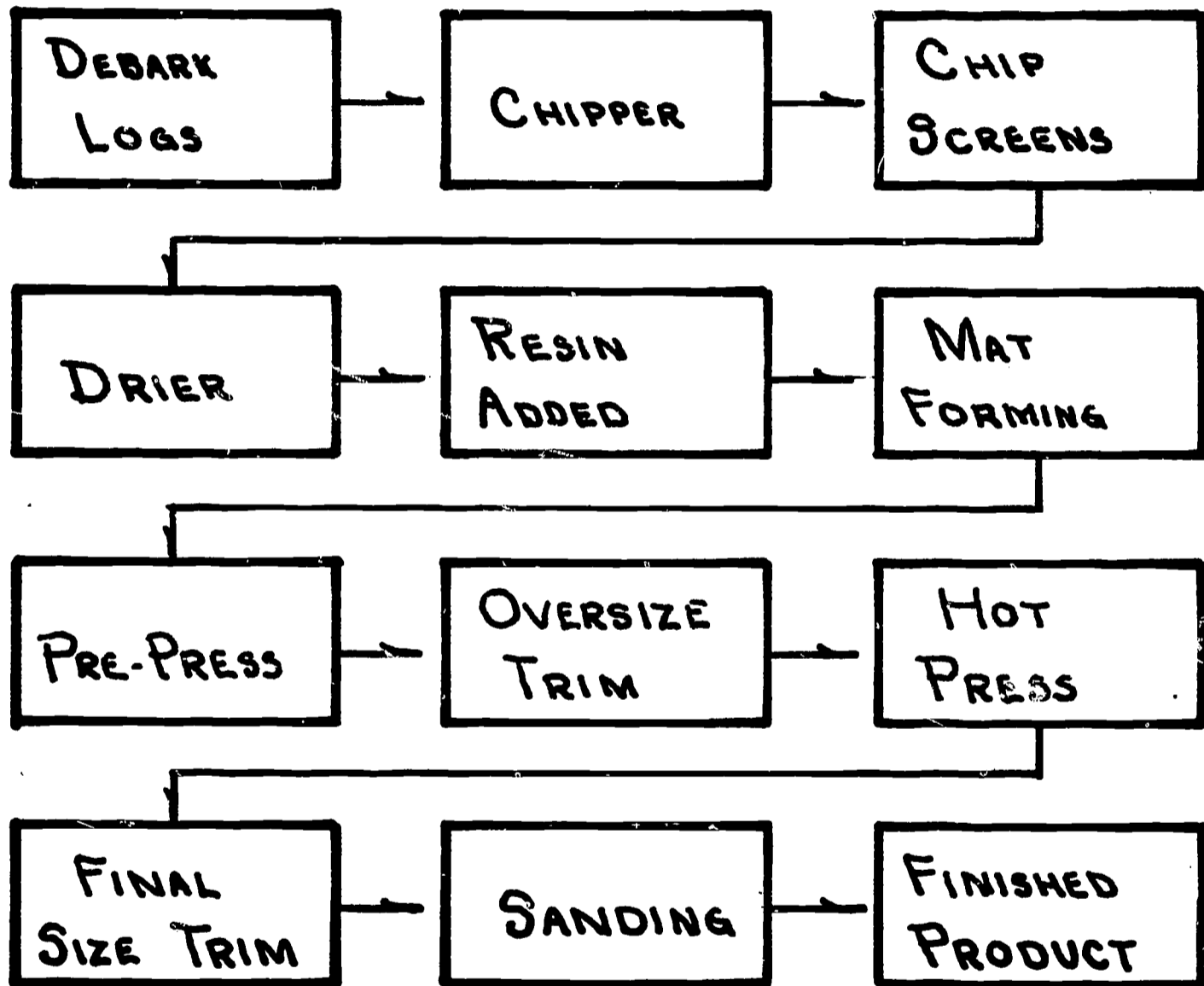



## THE CARE & USE OF TUNGSTEN CARBIDE CUTTING TOOLS

When properly cared for, carbide bits and cutters provide extra long life and economy. Even under abrasive conditions these tools will give ten to twenty times the life obtained from high speed steel. Although designed to withstand normal cutting force, care must be exercised in their use as carbide is a hard, brittle material. Bumps, shocks or vibrations can damage it. The following suggestions will assist you in obtaining maximum benefits from your carbide tools.

1. Never drop or let a carbide tool strike anything, as this may cause the carbide to crack or shatter.
2. When using machinery or tools such as wrenches near carbide tools, be extra cautious and don't strike the carbide and damage it.
3. Carbide tools must be mounted rigidly. Slippage, vibration, or loose spindle bearings may cause failure due to uneven cutting loads.
4. Always run the machine at full speed before starting the cut. Then, proceed with a steady feed and uniform load on the cutting edges.
5. At the first sign of a nick, crack or wear, remove the carbide tool and have it serviced at once.
6. If the need for more cutting pressure or a poor finish is noticeable, this indicates a dull tool and it should be immediately removed for servicing.
7. Carbide tools should be cleaned and honed at frequent intervals. Hone with a light, smooth stone. The hone should be cleaned as needed with kerosine.
8. When carbide tools become nicked, or if honing will not restore the cutting edge, have the tool reground by experienced personnel.
9. When not in use, each carbide tool should be wrapped separately, or provided with wooden hole pockets for storage.

The above material is reprinted from the February issue of Woodworking Digest, 1961.

## CHAPTER VI

### SUGGESTED TEACHING AIDS

#### I. FLOW CHART

A flow chart type bulletin board display covering the major operations from raw materials to the finished product.

#### II. SLIDES

Our institute group visited a particleboard manufacturing plant and were allowed to photograph the operations from the hog at the nearby sawmill to the finish sanding of the particleboard. This makes an excellent slide series for presenting first hand pictures and commentary to a class on the manufacturing of particleboard.

#### III. MANUFACTURING PARTICLEBOARD IN THE LAB

A two feet by four feet display panel with items mounted and labeled with respect to the manufacturing of particleboard specimens in the lab. These would be raw materials, jointed chips, screening device, fines, coarse chips, liquid urea resin, pre-pressed mat, hot-pressed particleboard, trimmed particleboard specimen. The chips, resin, and pre-pressed mat can be placed in plastic sandwich boxes for mounting.

#### IV. SAMPLE BOARD

This would be a board with a variety of samples of face and edge treatment of particleboard. Edge banding, T-moldings, high pressure laminate plastic faces and edges, low pressure laminate plastic faces and edges, wood veneered faces and edges, other overlays such as linoleum, carpet, vinyl sheets, clear finishes and painted surfaces and any other treatment that would fit face and/or edge treatment categories.

## CHAPTER VII

### MATERIALS, TOOLS & EQUIPMENT

As in any specialized area, the lab manufacturing of particleboard will necessitate some special tools and/or equipment. Some of the tools and equipment used will be found in most wood labs. A few items will have to be purchased or fabricated.

#### I. RAW MATERIALS

Two or three board feet of douglas fir for chips. Use three or four inch stock if possible. If these thicknesses are not available, glue up two inch stock to make the required size piece for chip making.

Liquid urea formaldehyde of 50 to 60% solids to be used as a binder.

#### II. CHIP MAKING EQUIPMENT

A circular saw for kerfing the chip stock, and a jointer for cutting the chips. A balance beam scale graduated in grams for weighing chips. See Figure 9.

#### III. BLENDING EQUIPMENT

An air source and spray gun for spraying the liquid resin binder onto the chips will be needed. Some type of mixer to keep chips rotating as the binder is being sprayed. This may be a small cement mixer such as shown in Figure 7. It could be purchased or fabricated.

#### IV. HOT-PRESS

A press with a minimum capacity of 2000 p.s.i., and electrically heated platens 6" x 6" or larger. This could be purchased or fabricated as shown in Figure 8. Figure 9 shows a deckle box for forming the mat which could be fabricated to size from  $\frac{1}{2}$ " aluminum. The compression block is made from hardwood to fit inside the deckle box. Welding gloves will aid in handling the hot specimens and give protection to the hands near the hot platens.

7

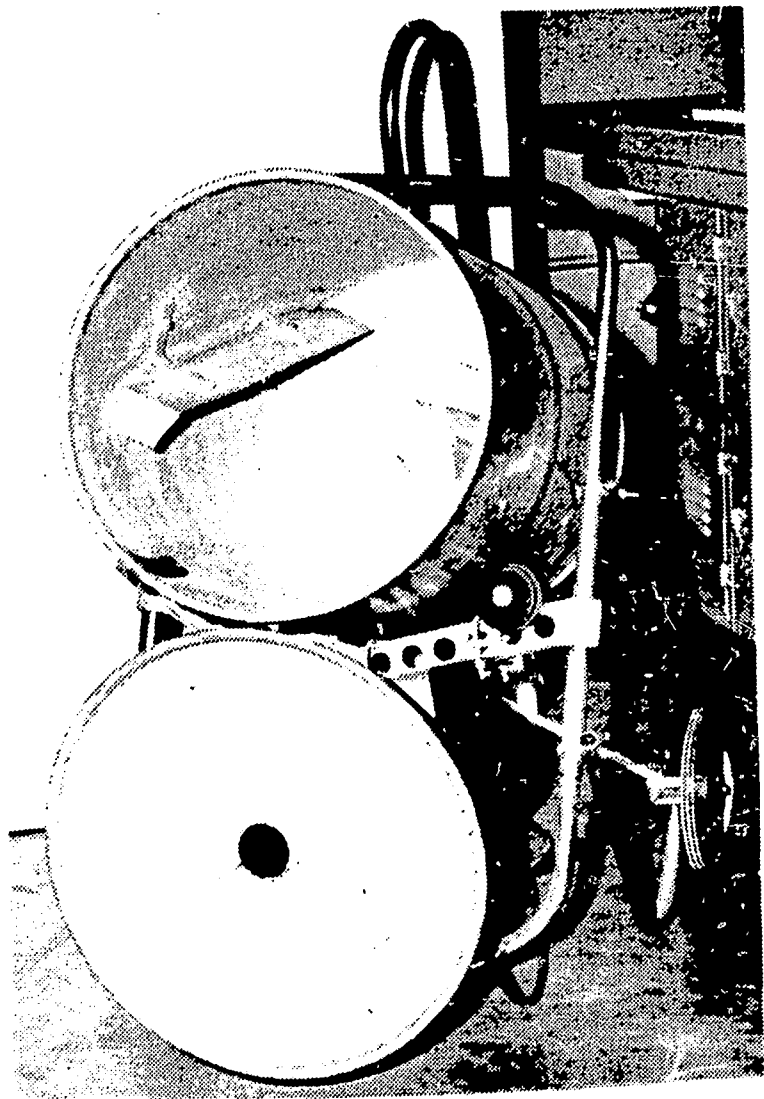

8

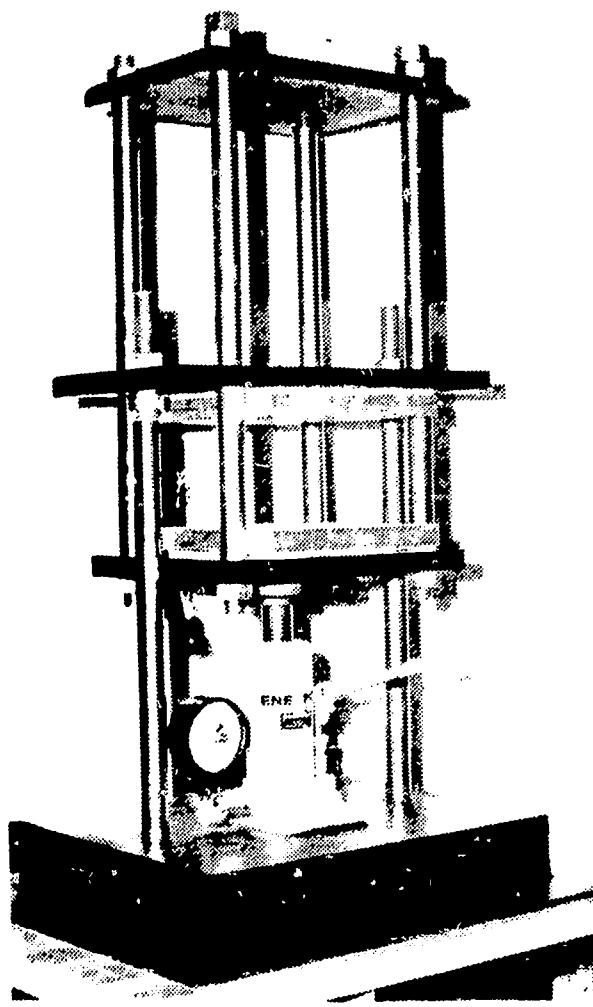

9

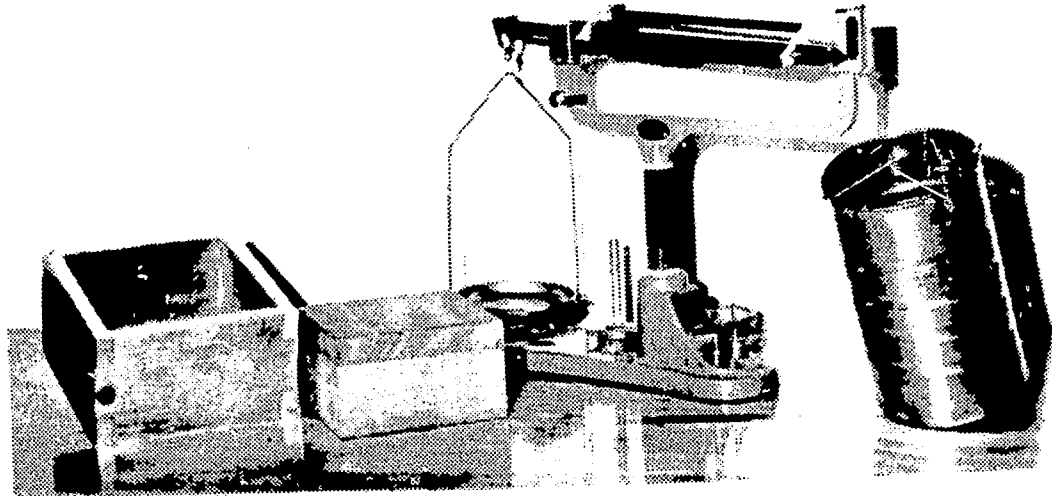

## BIBLIOGRAPHY

### A. BOOKS

1. Johnson, E. S. (ed.). Wood Particle Board Handbook. Raleigh, North Carolina: The Industrial Experimental Program of The School of Engineering, North Carolina State College, 1956.

### B. ORGANIZATIONS & GOVERNMENT PUBLICATIONS

2. Borden Inc./Chemical Division. Particleboard Manufacture. Service Bulletin 78h. New York: Borden Inc./Chemical Division, April 1968.
3. Lewis, Wayne C. Board Materials From Wood Residues. U. S. Forest Service Research Note O45, U.S. Department of Agriculture. Washington: Government Printing Office, April 1964.
4. National Particleboard Association. Particleboard Design and Use Manual. Washington: National Particleboard Association, 1966.
5. National Particleboard Association. The Story of Particleboard. Washington: American Forest Products Industries, Inc.

### C. PERIODICALS

6. Berrong, Howard, B.. "How board quality can be boosted," Forest Industries, 95:88-89, July 1968.
7. Connelly, Herbert, H, "The Truth About Particleboard," Furniture Design & Manufacturing, 39:60, May 1967.
8. Forest Industries. "Unusual Board Products Broaden Market Base," Forest Industries, 95:81, July 1968.
9. Graham, Paul H.. "Particleboard-Its Development, Processes, Properties, Markets," Woodworking Digest, 63:30-35, April 1961.
10. Lambert, Herb. "Board...Growth is evident, orderly; plant refinements, new products pushed," Forest Industries, 95:36-38, July 1968.

11. Woodworking Digest. "The Use & Care of Tungsten Carbide Cutting Tools," Woodworking Digest, 63:54, February 1961.
12. Wood, Warren, A. "New Forest Products and Techniques Offer Way Out of Competitive Rat Race," Wood and Wood Products, 72:28-30,80, October 1967.

D. UNPUBLISHED MATERIAL

13. Daugherty, Luther E. "A Laboratory Method of Making Wood Particleboard Specimens." Unpublished report, San Diego State College, San Diego, 1968.

LUMBER MERCHANDISING

---

Presented to  
Dr. Hammer  
San Diego State College

---

In Partial Fulfillment  
of the Requirements for the Course  
Industrial Arts 298

---

by

Al L. Bonan

Don Freeman

Ben Jones

Mike Thorsen

August 1968

## TABLE OF CONTENTS

CHAPTER	PAGE
I. THE PROBLEM AND DEFINITIONS OF TERMS USED . . . . .	1
Definitions of Terms Used . . . . .	3
Glossary . . . . .	9
II. REVIEW OF THE LITERATURE . . . . .	10
History . . . . .	10
Side Lines of the Lumbering Industry . . . . .	12
Related Lumber Products . . . . .	13
III. GRADING OF HARDWOODS . . . . .	14
Grading Rules . . . . .	14
IV. GRADING OF SOFTWOOD LUMBER . . . . .	19
Grading Rules . . . . .	19
V. PLYWOODS . . . . .	22
Types of Plywood Construction . . . . .	22
Main Kinds of Plywood . . . . .	22
Cutting Veneers from the Logs . . . . .	22
Plywood Production Continues to Gain . . . . .	23
How Veneers are Cut . . . . .	23
Key Definitions . . . . .	25
Classification of Species . . . . .	25
Veneer Grades Used in Plywood . . . . .	26
Grade - Use Guide for Engineered Grades of Plywood . . . . .	27



CHAPTER	PAGE
VI. MACERATED PRODUCTS . . . . .	28
VII. SUMMARY AND CONCLUSIONS . . . . .	29
BIBLIOGRAPHY . . . . .	31
APPENDIX . . . . .	32
SUGGESTED STUDENT LABORATORY EXPERIENCES . . . . .	33
HANDOUT SHEETS . . . . .	36
SUGGESTED TEACHING AIDS . . . . .	39

## CHAPTER I

### THE PROBLEM AND DEFINITIONS OF TERMS USED

Marketing plays an important part in all phases of lumbering and is the aggregate of functions involved in transferring title and in moving goods from producer to consumer, including among others, buying, selling, storing, transporting, standardizing, financing, risk bearing, and supplying market information.

We are all aware of the dramatic changes that have taken place in the last few decades in science and technology. The need for a specific product or process has brought about technical and engineering feats in the lumbering industry.

#### I. PROBLEM

Statement of the problem. A part of the requirement for the I.A. 298 in the 1968 N.D.E.A. Industrial Arts Institute in Woodworking Technology, San Diego State College, San Diego, California, under the auspices of the 1963 Secondary Education Act, our team was assigned the topic "Lumber Merchandising." Therefore, with this in mind we will set forth some of the basic rules dealing with the selection and specifications of some of the woods purchased for school use.

Importance of the study. The meteoric rise in labor costs and consequently the rise in the price of lumber plus the vanishing supply of the better grades of lumber and species, behooves the instructor and pupil to have a working knowledge of the grading rules and grades of lumber available in the various species. Many times a thorough knowledge of the different grades will result in a saving by purchasing the most economically suitable grade required for a particular purpose.

Limitations of the study. The questionnaire was used as the vehicle to rank the most commonly used woods.

Tabulations taken from the questionnaire indicated that of the thirty-four species of wood recorded, twelve were used most frequently. The rank was according to species purchased by each participant for his laboratory use.

Other items to be considered will include the more common grades of hard and soft woods, plywoods, macerated products, and related lumber products.

## II. DEFINITIONS OF TERMS USED

Bark. Outer layer of a tree, comprising the inner bark, or thin, inner living part (phloem), and the outer bark, or corky layer composed of dry, dead tissue.

Bark pocket. An opening between annual growth rings that contains bark. Bark pockets appear as dark streaks on radial surfaces and as rounded areas on tangential surfaces.

Birdseye. Small localized areas in wood with the fibers indented and otherwise contorted to form few to many small circular or elliptical figures remotely resembling birds' eyes on the tangential surface. Common in sugar maple and used for decorative purposes, rare in other hardwood species.

Bow. The distortion in a board that deviates from flatness lengthwise but not across its face.

Boxed heart. The term used when the pith falls entirely within the four faces of a piece of wood anywhere in its length. Also called boxed pith.

Brashness. A condition that causes some pieces of wood to be relatively low in shock resistance for the species and, when broken in bending, to fail abruptly without splintering at comparatively small deflections.

Bunker. A steel banded stack of dimensioned stock.

Burl. (1) A hard, woody outgrowth on a tree, more or less rounded in form, usually resulting from the entwined growth of a cluster of adventitious buds. Such burls are the source of the highly figured burl veneers used for purely ornamental purposes. (2) In wood or veneer, a localized severe distortion of the grain generally rounded in outline, usually resulting from overgrowth of dead branch stubs, varying from one-half inch to several inches in diameter; frequently includes one or more clusters of several small contiguous conical protuberances, each usually having a core or pith but no appreciable amount of end grain (in tangential view) surrounding it.

Cant. A log that has been slabbed on one or more sides.

Casehardening. A stressed condition in a board or timber characterized by compression in the outer layers accompanied by tension in the center or core, the result of too severe drying conditions.

Check. A lengthwise separation of the wood that usually extends across the rings of annual growth and commonly results from stresses set up in wood during seasoning.

Collapse. The flattening of single cells or rows of cells in heartwood during the drying or pressure treatment of wood, characterized by a caved-in or corrugated appearance.

Cord. A wood pile eight feet long, four feet high, and four feet wide (128 cubic feet).

Crook. A distortion of a board in which there is a deviation edgewise from a straight line from end to end of the board.

Crossband. To place the grain of layers of wood at right angles in order to minimize shrinking and swelling; also, in plywood of five or more plies, a layer of veneer whose grain direction is at right angles to that of the face plies.

Cup. A distortion of a board in which there is a deviation flatwise from a straight line across the width of the board.

Cutting. In hardwood lumber a cutting is a portion made by imaginary ripping, by crosscutting or by both.

Decay. The decomposition of wood substance by fungi.

Dimension stock. A term largely superseded by the term hardwood dimension lumber. It is hardwood stock processed to a point where the maximum waste is left at a dimension mill, and the maximum utility is delivered to the user. It is stock of specified thickness, width, and length, in multiples thereof. According to specification it may be solid or glued up, rough or surfaced, semifabricated or completely fabricated.

Dry rot. A term loosely applied to any dry, crumbly rot but especially to that which, when in an advanced stage, permits the wood to be crushed easily to a dry powder. The term is actually a misnomer for any decay, since all fungi require considerable moisture for growth.

Extractives. Substances in wood, not an integral part of the cellular structure, that can be removed by solution in hot or other solvents that do not react chemically with wood components.

Figure. The pattern produced in a wood surface by annual growth rings, rays, knots, deviations from regular grain such as interlocked and wavy grain, and irregular coloration.

Fitch. A portion of a log sawed on two or more sides and intended for remanufacture into lumber or sliced or sawed veneer. The term is also applied to the resulting sheets of veneer laid together in sequence of cutting.

Gang saw. A machine having a battery of circular saws, from twenty-two to twenty-six inches in diameter, all of which are fitted to the same shaft.

Grain. The direction, size, arrangement, appearance, or quality of the fibers in wood or lumber. To have a specific meaning the term must be qualified.

Green. Freshly sawed lumber, or lumber that has received no intentional drying; unseasoned. The term does not apply to lumber that may have become completely wet through water logging.

Hardwoods. Generally one of the botanical groups of trees that have broad leaves in contrast to the conifers or softwoods. The term has no reference to the actual hardness of the wood.

Honeycomb. A construction of thin sheet material, such as resin impregnated paper or fabric, which has been corrugated and bonded, each sheet in opposite phase to the phases of adjacent sheets, to form a core material whose cross section is a series of mutually continuous cells similar to natural honeycomb.

Honeycombing. Checks not visible at the surface that occur in the interior of a piece usually along the wood ray.

Kerf. The width of cut made by a saw.

Knot. That portion of a branch or limb which has been surrounded by subsequent growth of the wood of the trunk or other portion of the tree. As a knot appears on the sawed surface it is merely a section of the entire knot, its shape depending upon the direction of the cut.

Log. A section of the trunk of a tree in suitable length for sawing into commercial lumber.

Log scale. The board-foot content of logs as determined by a log rule.

Lumber. The product of the saw and planing mill not further manufactured than by sawing, resawing, passing lengthwise through a standard planing machine, crosscutting to length, and matching.

Mineral streak. An olive to greenish-black or brown discoloration of undetermined cause in hardwoods, particularly hard maples; commonly associated with bird pecks and other injuries; occurs in streaks usually containing accumulations of mineral matter.

Peck. Pockets or areas of disintegrated wood caused by advanced stages of localized decay in the living tree. It is usually associated with cypress and incense-cedar. There is no further development of peck once the lumber is seasoned.

Pitch pocket. An opening extending parallel to the annual growth rings containing, or that has contained, pitch, either solid or liquid.

Pitch streak. A well-defined accumulation of pitch in a more or less regular streak in the wood of certain conifers.

Pith. The small, soft core occurring in the structural center of a tree trunk, branch, twig, or log.

Plain sawed. Lumber sawed parallel with the pith of the log and approximately tangent to the growth rings; that is, the rings form an angle of less than  $45^{\circ}$  with the surface of the piece.

Quartersawing. Sawing at  $45^{\circ}$  to  $90^{\circ}$  angle to growth ring of tree.

Sapwood. The living wood of pale color near the outside of the log. Under most conditions the sapwood is more susceptible to decay than heartwood.

Seasoning. Removing moisture from green wood in order to improve its serviceability.



Shake. A separation along the grain, the greater part of which occurs between the rings and annual growth.

Softwoods. Generally, one of the botanical groups of trees that in most cases have needlelike or scalelike leaves; the conifers; also the wood produced by such trees. The term has no reference to the actual hardness of the wood.

Split. A lengthwise separation of the wood, due to tearing apart of the wood cells.

Stain. A discoloration in wood that may be caused by such diverse agencies as micro-organisms, metal, or chemicals. The term also applies to materials used to impart color to wood.

Twist. A distortion caused by the turning or winding of the edges of a board so that the four corners of any face are no longer in the same plane.

Veneer. A thin layer or sheet of wood cut on a veneer machine.

Wane. Bark or lack of wood from any cause on edge or corner of a piece.

Warp. Any variation from a true or plane surface. Warp includes bow, crook, cup, and twist, or any combination thereof.

## GLOSSARY

AD (Air Dried)

Bd. ft. or b.f. (Board foot; that is an area of one square)

Btr. (Better)

Com. (Common)

FAS (First and Seconds combined in one grade)

KD (Kiln Dried)

Lin. Ft. (Linear Foot, that is, twelve inches)

M (Thousand)

Qtd. (Quartered, or quarter sawn, when referring to hardwood)

Rfh. (Rough)

RWL (Random Width and Length)

S2S (Surfaced Two Sides)

S4S (Surfaced Four Sides)

WHAD (Worm Hole a Defect)

WHND (Worm Hole a Defect)

## CHAPTER II

### REVIEW OF THE LITERATURE

Much has been written about the propagation, harvesting, seasoning, processing, grading and marketing of the various species of hard and soft woods, plywoods, and macerated boards.

Material for this paper has been taken from books, magazines, periodicals, government publications, lectures, slides and films.

History. Man has been striving to advance his lot beginning with the selection of basic and simple wooden objects which were used as hunting and cultivation tools. By selection of these basic tools he began to set standards for materials and supplies which would meet his needs and those of his tribe and community. Man has continued to advance and develop his culture for several hundred thousand years. With the discovery of new materials, natural and man made, he has become the most sophisticated animal on earth.

The Middle Ages, which were partly brought about by intellectual stagnation and other causes, slowed down the processes of developing, selecting, grading and marketing of items. Several empires have risen and fallen prior to this time and each has contributed to the development of most cultures as we know them today.

The Renaissance which followed the Dark Ages gave man a re-birth in all phases of life, namely spiritual and earthly. Man picked up the tools of his culture and began to develop new and better ways of doing things and has continued to do so hence. Crafts flourished, guilds developed, merchants needed new and raw material outlets for their wares which in turn brought about the need for better and faster transportation.

The foregoing statements, it is hoped, will help orientate the reader, student and set the stage for one small part of the total part of business, namely, the lumber

industry. Man has been developing grading standards, manufacturing specifications, inspection certification.

In the early days of the industry there were comparatively few mills, the daily output small, the location was close to the market and the raw material in the form of logs was abundant and of good size and quality. Consequently lumber was cheap and the demand was for clear boards only of the highest quality. This demand for only the best boards naturally resulted in much waste and little demand for the medium and lower grades of lumber.

"The word 'lumber' first appears in records in Boston in 1663, truly an American word." (7:48) Lumber has been defined as "the product of the saw and planing mill, not further manufactured than by sawing, resawing, and passing lengthwise through a standard planing machine, crosscutting to length and working." (1:2, 9) The first saw mills were reportedly built at Jamestown, Virginia, in 1625, and at Berwick, Maine, in 1631. The waterwheel was the source of power for about 200 years before the advent of steam early in the nineteenth century. It was indeed fortunate that this change came about because the demand for lumber was greatly accelerating at this time. (1:2).

For over two hundred years, Maine was the hub of the lumber industry. Around 1850 the shift was to New York. By the later 1860's that state produced one-fifth of the lumber output of the entire country. (1:2). The Industrial Revolution in the latter part of the nineteenth century is to date the largest single contributing factor leading to the refined and technically engineered wood products we have today.

The next decade was to see a shift to huge mills along the Susquehanna River in Pennsylvania. From here the shift was to the Lake States. From Michigan the move was to Wisconsin and then to Minnesota. In the early 1900's the pine production of the nation, as well as the southern pine output, reached its peak. From the South the jump across the Rockies to Washington and Oregon produced great quantities of Douglas fir, hemlock, cedar, spruce, redwood and pine. Today the western regions constitute a major source of our softwood lumber supply. It appears likely

that the South may soon outrank the West since it has the largest commercial forest land area and the advantage of extremely fast growing trees (1:2,3).

Side Lines of the Lumbering Industry. The lumbering industry today is a gigantic industry with more than 1,010 companies operating in the United States and Canada. As of April 9, 1968, fifteen and eight-tenths billion board of lumber was produced by these companies. The total lumber production in 1967 of the same companies was 27,423,791,334 bd. ft. and one can readily determine the 1968 production is well ahead of the 1967 production in that when the 1968 tally was taken in April the harvest was one-third complete. If the rate of production holds its present trend the 1968 production will be twenty billion bd. ft. above the 1967 production (2:40).

Many companies in foreign lands are competing with American firms for timber grown along the west coast of the United States. To help remedy this costly problem the U. S. Government placed restrictions on the amount of timber that can be exported from Government lands.

Japan is determined to outbid domestic timber users for Washington state's unregulated public wood supply, said John H. Martinson, general manager of Anacortes Veneer, Inc., recently. He said the Japanese were bidding as much as 78 per cent above the appraised value on sales made before the federal restrictions were approved in April. He quoted State Land Commissioner Bert Cole about one sale involving 117 million bd. ft. of state timber appraised at \$3.4 million and sold for \$6.8 million (6:6).

Martinson said that "Washington is the only government unit on the Pacific Coast which allows unlimited export of a critically short raw material from public land. More than sixty per cent of the logs exported to Japan come from private timberland."

In Washington, D. C., Sen. Wayne Morse (D-Ore.) and the Senate Small Business committee called for more limitations and also for positive action by industry to limit log exports. Morse and the committee expressed great

dissatisfaction with the controls put into effect last April by Secretary of Agriculture Orville L. Freeman.

Japanese protest log action of April 1968. The Japan Assn., the Japanese Wholesalers Assn., and a group comprising importers, wholesalers and sawmill interests have protested U. S. Government restrictions on unprocessed logs from federal lands in the Pacific Northwest, reports the Western Wood Products Assn. Spokesmen for the Japanese lumber interests said that if restrictions were extended they would ask the Japanese government to take some retaliatory action (6:6).

The articles reviewed are only a few of a myriad of problems that are being constantly fought to help the balance of trade and insure jobs for American labor. Many other related problems are connected with this log action that cannot be discussed at this time.

Related Lumber Products. The need for products derived from different species of trees is a long one and is growing by leaps and bounds. Many of the products taken from trees are used in their natural form and some without modification or refining. On the other hand there are many products that are subjected to elaborate chemical or physical changes that make some fit for human as well as industrial consumption. Listed are a few of the products that are derived from trees: Fruits, tanning bark, tea, drugs, particle board, plywood, paper, mulching, excelsior, hardboard, craft paper, pine oil, rosin, cosmetics, charcoal, spices, turpentine, coffee, cocoa, nuts, insecticides, molasses, alcohol, plastics, rayon.

## CHAPTER III

### GRADING OF HARDWOODS

The National Hardwood Lumber Association (N.H.L.A.) was organized in 1898. Until that time, prices of hardwoods were meaningless. The advent of a grading organization brought stability to a hitherto unorganized state of confusion in the hardwood industry.

Until the advent of a grading association, business was done by mutual inspection, both the buyer and seller had to have a representative present at the lumber site to argue the merits of the lumber and its selling price.

Today, the N.H.L.A. has a staff of over a hundred inspectors and a universally accepted inspectors' set of grading rules by which lumber can be produced, distributed and used with full confidence (7: 2).

Grading Rules. Some of the more important information rules pertinent to the Industrial Arts teacher, so he may correctly specify and receive most for his money, will be mentioned.

Most hardwoods are plain sawed to secure the maximum log yield and wider widths. Sometimes logs are quarter sawed to obtain special strength properties or figures. The grade of a board is determined from the poor side of the piece unless otherwise specified (7:5).

The rules define the poorest piece in any given grade but the grade shall contain all pieces up to the next higher standard (7:10).

Ninety per cent of the minimum width mentioned in all grades shall be full width, the remaining ten per cent may be up to one-fourth inch scant in width (7:10).

Lumber of specified width, rough or dressed shall be  $3/8$ " scant of nominal width in lumber less than eight inches wide and  $1/2$ " scant of nominal width in lumber eight inches and wider (7:10).

Standard lengths are 4', 5', 6', 7', 8', 9', 10', 11', 12', 13', 14', 15', but not over fifty percent of odd lengths will be admitted (1:10).

Standard thicknesses for rough lumber are  $3/8$ ",  $1/2$ ",  $5/8$ ",  $3/4$ ", 1",  $1\ 1/4$ ", 2",  $2\ 1/2$ ", 3",  $3\ 1/2$ ", and 4". Sometimes one inch and thicker may also be expressed in quarter inches as follows:  $4/4$ ,  $5/4$ ,  $6/4$ , etc. (7:10).

Standard thicknesses for surfaced lumber are as follows:

<u>Rough</u>		<u>Surfaced</u>		<u>Rough</u>		<u>Surfaced</u>
$3/8$ "	S2S	to	$3/16$ "	1"	S2S	to $13/16$ "
$1/2$ "	S2S	to	$5/16$ "	$1\ 1/4$ "	S2S	to $1\ 1/16$ "
$5/8$ "	S2S	to	$7/16$ "	$1\ 1/2$ "	S2S	to $1\ 5/16$ "
$3/4$ "	S2S	to	$9/16$ "	2"	S2S	to $1\ 3/4$ "
1"	S2S	to	$13/16$ "	$2\ 1/2$ "	S2S	to $2\ 1/4$ "
						(7:10).

Any lumber less than one inch thick is figured as one inch. Lumber measured with a board rule, random width pieces measuring to the even half foot shall be alternately counted as the next higher and lower foot; fractions below the half foot shall be dropped and fractions above the half foot shall be counted as the next higher foot. Fractional lengths in standard grades shall be measured as the next lower standard length (7:11).

Tapering lumber in standard lengths shall be measured one-third in length of the piece from the narrow end (1:11).

In lumber thicker than one inch the board feet are obtained by multiplying by the thickness expressed in inches and fraction of an inch (7:11).



Rough dimension stock shall be counted as of the nominal specified size. Where surfaced it shall be counted as of the nominal rough size required in its manufacture (7:11).

Ordinary season checks are admitted in clear face cuttings. Season checks that do not impair the strength are admitted in sound cuttings and construction grades (7:11).

Stain shall not be admitted in cuttings unless it will dress out in surfacing to standard thickness for surfaced lumber, except grades of woods where rules specifically state stain is admitted (7:11).

A cutting is a board obtained by cross cutting or ripping or both. A cutting shall be flat enough to surface two sides to standard surfaced thickness after it has been removed from the board (7:12).

A clear face cutting is one having one clear face (season checks are admitted) and the reverse side sound as defined in sound cutting. The clear face shall be on the poor side of the board except when otherwise specified (7:12).

A sound cutting is free from rot, pith shake or wane. It will admit sound knots, bird pecks, stain, and season checks not materially affecting the strength of the cutting, pin, shot, and spot wormholes (7:12).

Lumber grade can be determined by the cutting units in a board. The cutting unit is one inch by one foot. To obtain the number of cutting units in a board multiply the width in inches by the length in feet to attain the number of cutting units in a board (7:13).

Firsts usually admit pieces that yield  $91\frac{2}{3}\%$  ( $11/12''$ ) clear face cuttings as follows: 4' to 9' surface measure in one cutting; 10' to 14' in two cuttings; 15' and over in three cuttings (7:15).

Seconds usually admit pieces that will yield 83-1/3% (10/12") clear cuttings as follows: 4' to 7' surface measure in one cutting; 8' to 11' in two cuttings; 12' to 15' in three cuttings (7:15,16).

Selects usually admit pieces that will yield 91-2/3% (11/12") clear face as follows: 2' to 3' and pieces 4' and over that will grade on one face as required in seconds, the reverse side a sound cutting (7:16).

Number one common admits pieces four inches wide by two feet long or three inches wide by three feet long except that in pieces less than three inches wide, cuttings the full width of the piece is admitted. Pith shall not exceed one-half length of piece (7:16).

In firsts and seconds (FAS), widths are six inches and wider, 8' to 16' in lengths admitting thirty per cent of the 8' to 11' of which one-half may be 8' and 9'. Selects are 4" and wider, lengths 6' to 16' admitting thirty per cent of the 6' to 11', of which one-sixth may be 6' to 7' (7:15).

Number one common widths are 3" and wider, admitting 5% of 3" widths, lengths are 4' to 16' admitting 10% of 4' to 7', of which one-half may be 4' and 5' (7:16).

The following grades exist below that on Number one common, but will be mentioned first. They are: Number 2 common, sound wormy, Number 3A common, and Number 3B common (7:17).

Some of the exceptions to the above rules for the hardwoods most used, by the group this summer, are as follows: Philippine mahogany will grade slightly wider and longer than standard rules. (7:32)

Walnut that has been steamed and is sold and specified as "steamed walnut," sapwood shall not be considered a defect. Odd lengths are admitted without limit. Firsts and seconds are one grade. Over all walnut will grade lower than the

standard for FAS. Shorter widths, shorter lengths and more defects are admitted in the different grades (7:25,26).

Plain oak is standard, quartered oak. Firsts are standard, seconds admit widths 5" and wider; pieces 5" wide containing 3' and 4' surface measure shall be clear, pieces 5" wide containing 5' to 7' surface measure shall yield 11/12" (91-2/3%) clear-face in one cutting (7:21).

Cherry will grade slightly lower than standard in all grades. Some cherry is sold and specified "sapwood, gum spots and streaks no defects," small knots or their equivalent not exceeding 1/8" in diameter shall be admitted in cuttings (7:25).

Ash is standard except 40% 8' to 11' lengths FAS and 40% 6' to 11' (7:19).

Aromatic red cedar grades Number 1 common and better and Number 2 common. It will admit sound knots, white streaks and gum, tight pith in cutting, which are otherwise sound. Number 1 common and better admits widths 3" and wider, 25% of the 3" width. Lengths are 3' and longer, admitting 10% of the 3' to 5' lengths (7:31). Birch, as well as willow, grade standard (7:19, 23).

Gum has so many variations it would be best to refer to the grading rules.

The above rules have been condensed from the National Hardwood Lumber Association Rules for the Measurement and Inspection of Hardwood and Cypress Lumber. January 1965-1966. If more detailed information is needed refer to these rules.

## CHAPTER IV

### GRADING OF SOFTWOOD LUMBER

Because of the nature of the wood, many more grades of softwood lumber are produced than in hardwoods. Since lumber is a by-product of nature and so many variations occur there can be no hard and fast rules. Only the general features of the different grades should be described by rules of inspection. In grading the select and common grades, the face side determines the grade. This is the surfaced face in case only one is surfaced and the best face in the case of S2S lumber. The grade a board receives is determined not only by the number and size defects it has but also by the size of the board and how well the defects are distributed (8:5,6).

Grading Rules. West Coast Lumber (WCLB) rules indicate 15% moisture content if a symbol "MC15" is used, and if the symbol "DRY" appears it indicates a maximum 19% moisture content. Optional maximum moisture standard of seasoned lumber shipped in closed conveyances shall be for 4/4 or 8/4 shop or select, 85% of the item with a M.C. of 15% or less with a maximum of 18% (WWPA) Western Wood Products Association. If specified or represented as kiln dried, 85% of the items should be 12% or less with a maximum of 15% (8:8).

Since ponderosa pine is one of the commonly used pines the grading rules will apply to this species. There are three finish grades, namely: B and better select, sometimes called Number 1 and 2 clear. Stock is 4" and wider and up to 16' long and comes in various thicknesses. This is the highest grade and admits one or two minor blemishes that do not detract from its appearance. It is suitable for a clear finish or both sides (8:13).

C select is the second highest grade and similar to B and better except that it grades from the best side with imperfection allowed on the other side. It is produced with the idea of providing a high class paint surface. D select is the lower of the three select grades. Numerous small knots and other small defects are found in this grade and often with a cut or two produces very good pieces (8:14).

Rules for the most part are explained by examples. An example of a board that would grade B and better should be as follows: 1" x 10" x 16' -0". Has a very small dry pitch pocket near one end, otherwise the piece is perfect. An example of C select is as follows: 1" x 8" x 16' -0". Very smooth in appearance with two inches of light stain tapering off at four feet and three feet from the other end is a five-eighths inch knot firmly set. An example of D select is as follows: 1" x 12" x 16', has approximately one-eighth inch cup, but may contain an additional one-sixteenth inch cup for each additional four inches in width. It also has a high D select face (8:13, 14, 15).

The poorer grades of pine are classified as Number 1, Number 2, Number 3, Number 4, and Number 5 common. Since only Number 1 and Number 2 common have much application in a wood shop only an example of these two will be given. Number 1 includes all sound tight knots with the size the determining factor of the grade. Some season checks, light stain or equivalent characteristics are admissible. An example is as follows: 1" x 6" x 16', has nine red knots from one to one and a half inches in size and three small black knots firmly set. Number two grades similar to Number 1 except the characteristics admissible and larger and more pronounced. Some maximum characteristics are as follows: 1" x 8" x 16', contain twelve red knots from one to two and a half inches in size, several small pitch pockets and several roller checks on the reverse side (8:16).

Also of interest to the shop teacher are the factory or shop grades of lumber. They are graded with reference to their cutting size much the same as hardwoods are graded. Three grades of note are: Factory select (No. 3 clear) No. 1 shop, and No. 2 shop.

In using lumber, whether it be softwoods or hardwoods, the shop instructor should always strive to use the lowest grade of lumber that will satisfactorily fulfill the needs of a particular project.

Many lumber dealers base their board foot prices on the quality of lumber ordered. A common dividing point is 500 B.F. By combining quantities of several kinds of lumber an additional two to four cents savings per bd. ft. may be obtained.

In buying lumber, if a surfacer is available, it is most economical to buy lumber not surfaced (rough). Otherwise it is at least necessary to buy lumber surfaced two sides (faces).

Specifications should include the following: (1) quantity wanted, (2) rough thickness, (3) grade, (4) kind of wood (species), (5) surface condition (Rgh., S2S, S4S), (6) type of seasoning desired, and perhaps moisture content, (7) widths and lengths (RWL in the case of most hardwoods) (4:23).

Be sure to check and recheck specifications, and be sure the specifications are complete.

## CHAPTER V

### PLYWOODS

Plywood dates back many thousands of years. We have records to show that plywood was used at least 400 B. C. in the construction of mummy cases and coffins for Egyptian Rulers. But the last forty years has shown the greatest expansion in the plywood industry, and the only real new thing in plywood is the glues.

Types of Plywood Construction. Cross-banded wood made up of an odd number of veneer sheets glued together, the grains of the layers at right angles to one another (3, 5, 7, 9, 11) 1/4" to 3/4" in thickness.

Plywood core, a lumber center or base, usually of softwood, on which veneers are glued. 1/4" to 3/4" in thickness. Core materials used are poplar, bass, spruce, and hemlock.

#### Main Kinds of Plywood.

Interior - Moisture resistant

Exterior - Waterproof

Boat hull - 3/8" x 48" x 192"

Construction - Faces oiled, edges sealed

Special plywood - (Bending plywood) 1/8" thickness by 60" x 144", veneer or lumber core.

Cutting Veneers from the Logs. The log is cut to the desired length, centered in the barking machine where the bark is removed and at the same time the log is cut to an even cylinder.

Rotary cutting or peeling is accomplished after the log has been centered in the "chucks" and rotated against a keen-cutting blade. The thin layer of wood is removed and unwound much like paper from a roll 1/10 to 3/16 thick.

Slicing is accomplished by clamping the log to the back plate which swings down at an angle past the knife edge removing a sheet of veneer from the face of the log.

Plywood Production Continues to Gain. Plywood production in the United States through the first five months of the year totaled about six billion square feet, up from 5.25 billion square feet in the same period last year. American Plywood Assn. also notes that the 750 million square feet increase (14 per cent ahead of 1967) is equivalent to three weeks of average production for the entire softwood plywood industry. Industry production in June and August will total approximately 275 million square feet, or 96 percent of current operating capacity. Weekly production in July will drop off to about 240 million square feet (84 per cent of capacity) because of the usual mill shutdowns for vacations. The plywood association is still predicting that the industry will produce some 14 billion square feet in 1968 on the strength of an active first half (6:8).

How Veneers are Cut. A log selected for architectural veneers may be cut in various ways, the method being dependent not only on the species but on the type of figure or pattern which that particular log is capable of producing in its veneers. No two trees can ever be exactly alike. Their grain patterns are as individual as fingerprints.

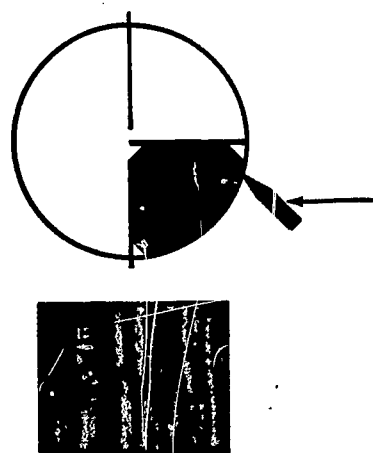

**Quarter slicing** The quarter log or flitch is mounted on the guide plate so that the growth rings of the log strike the knife at approximately right angles, producing a series of stripes, straight in some woods, varied in others.

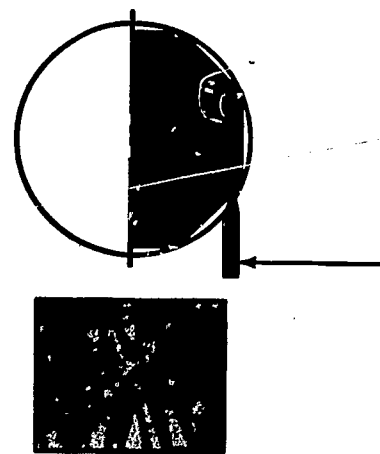

**Plain slicing (or flat slicing)** The half log, or flitch, is mounted with the heart side flat against the guide plate of the slicer and the slicing is done parallel to a line through the center of the log. This produces a variegated figure.



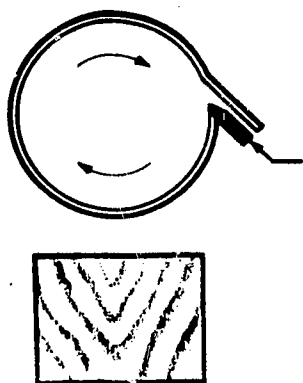

**Rotary** The log is mounted centrally in the lathe and turned against a razor sharp blade, like unwinding a roll of paper. Since this cut follows the log's annular growth rings a bold variegated grain marking is produced. Rotary cut veneer is exceptionally wide, and cannot be sequence matched.

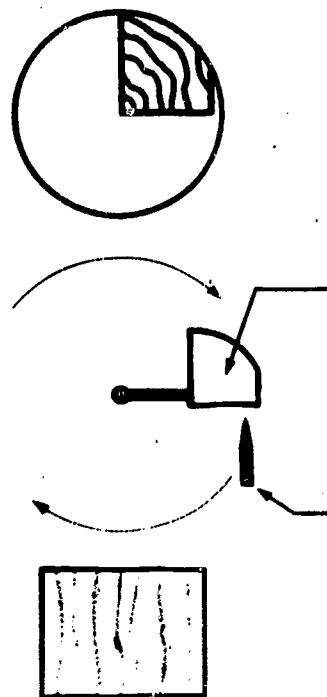

**Rift-cut** Rift cutting is used to produce **Comb Grain Oak** veneers. The medullary ray cells of Oak radiate from the center of the log like the curved spokes of a wheel. By cutting perpendicularly to these rays a comb effect results. Rift cutting can be done on either the lathe or the slicer.

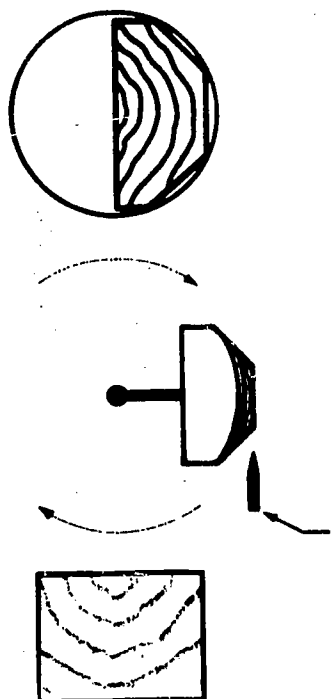

**Half-round** Segments or flitches of the log are mounted off center in the lathe, resulting in a cut slightly across the annular growth rings. Half round shows modified characteristics of both rotary and plain sliced veneers.

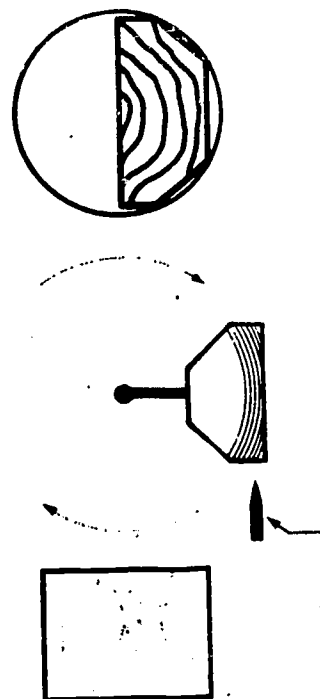

**Back-cut** The flitch is mounted as in half-round cutting except that the bark side faces in towards the lathe center. The veneers so cut are characterized by an enhanced striped figure and the inclusion of sapwood along the edges.

## Key Definitions:

### Plywood:

A panel product made from a number of thin sheets of wood (veneers). Select logs are peeled in giant lathes to form veneer of uniform thickness. This material is bonded with the grain of each ply running at right angles to adjacent plies. Cross-bonding produces high strength in both directions providing a basic light-weight panel product ideal for hundreds of uses in construction and industry.

### Type:

Plywood is manufactured in two types—Exterior type with 100 per cent waterproof glue and Interior type with highly moisture resistant glue. Veneers used in inner plies in Interior type plywood may be of lower grade than those in Exterior type. Specify Exterior type for all exposed applications. Interior type plywood is highly moisture resistant but the bond is not permanently waterproof. It may be used anywhere it will not be subject to continuing moisture conditions or extreme humidity.

### Grade:

Within each type of plywood there is a variety of appearance grades determined by the grade of the veneer (N, A, E, C, or D) used for the face and back of the panel. Grades are generally designated by type of glue and by veneer grade on the face and back.

### Product Standard:

Softwood plywood is manufactured in accordance with Product Standard PS 1-66 for Softwood Plywood—Construction and Industrial. American Plywood Association's DFPA grade-trademarks are positive identification of plywood manufactured in conformance with PS 1-66 and rigid quality standards of the Association.

### Group:

Plywood is manufactured from some 30 different species of varying strength. Species involved have been grouped on the basis of stiffness and, for purposes of Product Standard PS 1-66, divided into four classifications designated Group 1, Group 2, Group 3 and Group 4. Strongest woods are found in Group 1. (See table below). The Group number that appears

in the DFPA grade-trademark is based on species used in face and back.

### STRUCTURAL I, STRUCTURAL II:

New unsanded construction grade under Product Standard PS 1-66. Special limitations on species. Made only with Exterior glue. Designed for demanding construction applications where properties such as nail-bearing, shear, compression, tension, etc., are of maximum importance. Examples: roof decking engineered as a structural diaphragm, box beams, gusset plates, stressed-skin panels and shipping containers.

### STANDARD (with Exterior glue):

Interior type STANDARD C-D sheathing is also available with fully waterproof adhesives identical to those used in full Exterior type grades. Although these panels will retain their structural integrity under most conditions, the presence of D veneers in inner plies and backs may result in localized glueline weakness when subject to wet or highly humid conditions.

### Identification Index Number:

A set of two numbers separated by a slash that appears in the grade-trademarks on STANDARD sheathing, STRUCTURAL I, STRUCTURAL II and Exterior C-C. Number on left indicates spacing in inches for supports when the panel is used for roof decking. The number on the right shows the spacing in inches for supports when the panel is used for subflooring. (See back cover.)

### Class I, Class II:

Applies only to Plyform grade for concrete form applications. Indicates species mix permitted in this grade. Plyform Class I limited to Group 1 faces, Group 1 or Group 2 core, species of any group for center. Plyform Class II limited to Group 1 or Group 2 faces, species of any group for inner plies. Optional make-up for Plyform Class II permits faces of Group 3 if 1/8" thick before sanding and if core is limited to Group 1, 2, or 3 species.

### Classification of Species

Group 1	Group 2	Group 3	Group 4
Douglas fir 1 Larch, Western Pine, Southern Loblolly Longleaf Shortleaf Slash Tanoak	Cedar, Port Orford Douglas fir 2 Fir California red Grand Noble Pacific Silver White	Hemlock, Western Lauan Red White Pine, Western white Spruce, Sitka	Alder, red Cedar, Alaska yellow Pine Lodgepole Ponderosa Redwood Cedar Incense Western red Fir, subalpine Pine, sugar Poplar, Western Spruce, Engelmann
Douglas fir 1—Washington, Oregon, California, Idaho, Montana, Wyoming, British Columbia, Alberta. Douglas fir 2—Nevada, Utah, Colorado, Arizona, New Mexico.			

© Copyright 1966 American Plywood Association.

## Veneer grades used in plywood

(Summary...see PS 1-66 for complete specifications.)

Veneer Grade	Defect Limitations
<p><b>N</b></p> <p>Intended for Natural Finish</p> <p>Presents smooth surface.</p> <p>Veneer shall be all heartwood or all sapwood free from knots, knotholes, splits, pitch pockets, other open defects, and stain, but may contain pitch streaks averaging not more than 3/8" wide blending with color of wood.</p> <p>If joined, not more than two pieces in 48" width; not more than three pieces in wider panels. Joints parallel to panel edges and well-matched for color and grain. Repairs shall be neatly made, well-matched for color and grain, and limited to a total of six in number in any 4' x 8' sheet.</p>	<ul style="list-style-type: none"> <li>• Maximum of three "router" patches not exceeding 3/4" x 3-1/2" admitted. No overlapping.</li> <li>• Shims admitted not exceeding 12" in length but may occur only at ends of panel. (Examples of permissible combinations: 3 router patches and 3 shims, 2 router patches and 4 shims, 1 router patch and 5 shims, or 6 shims).</li> </ul> <p>Suitable synthetic fillers may be used to fill 1/32" wide checks, splits up to 1/16" x 2", and chipped areas or other openings not exceeding 1/8" x 1/4".</p>
<p><b>A</b></p> <p>Presents smooth surface.</p> <p>Admits—Pitch streaks blending with color of wood and averaging not more than 3/8" in width.</p> <ul style="list-style-type: none"> <li>—Sapwood.</li> <li>—Discolorations.</li> </ul> <p>Veneer shall be free from knots, knotholes, splits, pitch pockets and other open defects. If of more than one piece, veneer shall be well joined.</p> <p>Repairs shall be neatly made, parallel to grain, and limited to 18 in number in any 4' x 8' sheet, excluding shims; proportionate limits on other sizes.</p>	<p>Patches of "boat," "router," and "sled" type only, not exceeding 2-1/4" in width, and may be die-cut if edges are cut clean and sharp. Radius of ends of boat patches shall not exceed 1/8".</p> <ul style="list-style-type: none"> <li>• Multiple patching limited to 2 patches, neither of which may exceed 7" in length if either is wider than 1".</li> <li>• Shims admitted except over or around patches or as multiple repairs.</li> </ul> <p>Suitable synthetic fillers may be used to fill 1/32" wide checks, splits up to 1/16" x 2", and chipped areas or other openings not exceeding 1/8" x 1/4".</p>
<p><b>B</b></p> <p>Presents solid surface.</p> <p>Admits—Knots up to 1" across the grain if both sound and tight.</p> <ul style="list-style-type: none"> <li>—Pitch streaks averaging not more than 1" in width.</li> <li>—Discolorations.</li> <li>—Slightly rough but not torn grain, minor sanding and patching defects, including sander skips not exceeding 5% of panel area.</li> </ul> <p>Veneer shall be free from open defects except for splits not wider than 1/32", vertical holes up to 1/16" in diameter if not exceeding an average of one per square foot in number, and horizontal or surface tunnels up to 1/16" in width and 1" in length not exceeding 12 in number in a 4' x 8' sheet (proportionately on other sizes). Repairs shall be neatly made and may consist of patches, plugs, synthetic plugs and shims.</p>	<ul style="list-style-type: none"> <li>• Patches may be "boat," "router," and "sled" type not exceeding 3" in width individually when used in multiple repairs or 4" in width when used as single repairs.</li> <li>• Plugs may be "circular," "dog-bone," and "leaf-shaped," not exceeding 3" in width when used in multiple repairs or 4" in width when used as single repairs.</li> <li>• Synthetic plugs shall present a solid, level, hard surface not exceeding above dimensions.</li> </ul> <p>Suitable synthetic fillers may be used to fill small splits or openings up to 1/16" x 2", and chipped areas or other openings not exceeding 1/8" x 1/4".</p>
<p><b>C</b></p> <p>Admits—Tight knots up to 1 1/2" across the grain.</p> <ul style="list-style-type: none"> <li>—Knotholes not larger than 1" across the grain. Also an occasional knothole not more than 1 1/2" measured across the grain, occurring in any section 12" along the grain in which the aggregate width of all knots and knotholes occurring wholly within the section does not exceed 6" in a 48" width, and proportionately for other widths.</li> <li>—Splits 1/2" by one-half panel length; 3/8" by any panel length if tapering to a point; 1/4" maximum where located within 1" of parallel panel edge.</li> <li>—Worm or borer holes up to 3/8" x 1 1/2".</li> </ul>	<p>Repairs shall be neatly made and may consist of patches, plugs, and synthetic plugs.</p> <p>Patches ("boat," including die-cut) not exceeding 3" in width individually when used in multiple repairs or 4" in width when used as single repairs. Plugs may be circular, "dog-bone" and leaf-shaped. Synthetic plugs shall present a solid, level, hard surface not exceeding above dimensions.</p>
<p><b>C</b> (plugged)</p> <p>Admits—Knotholes, worm or borer holes, and other open defects up to 1/4" x 1/2".</p> <ul style="list-style-type: none"> <li>—Sound tight knots up to 1 1/2" across the grain.</li> <li>—Splits up to 1/8" wide.</li> </ul>	<ul style="list-style-type: none"> <li>—Ruptured and torn grain.</li> <li>—Pitch pockets if solid and tight.</li> <li>—Plugs, patches and shims.</li> </ul>
<p><b>D</b></p> <p>D veneer used only in interior type plywood and may contain plugs, patches, shims, worm or borer holes.</p> <p>Backs:</p> <p>Admits tight knots not larger than 2 1/2" measured across the grain and knotholes up to 2 1/2" in maximum dimension. An occasional tight knot larger than 2 1/2" but not larger than 3" measured across the grain or knothole larger than 2 1/2" but not larger than 3" maximum dimension, occurring in any section 12" along the grain in which the aggregate width of all knots and knotholes occurring wholly within the section does not exceed 10" in a 48" width and proportionately for other widths.</p> <p>Inner Plys:</p> <p>Knotholes limited as for backs.</p>	<p>All Plys:</p> <p>Pitch pockets not exceeding 2-1/2" measured across the grain.</p> <p>Splits up to 1" except in backs only not more than one exceeding 1/2"; not exceeding 1/4" maximum width where located within 1" of parallel panel edge; splits must taper to a point.</p> <p>White pocket in inner plys and backs, not exceeding three of the following characteristics in any combination in any area 24" wide by 12" long.</p> <ol style="list-style-type: none"> <li>(a) 6" width heavy white pocket.</li> <li>(b) 12" width light white pocket.</li> <li>(c) One knot or knothole or repair 1-1/2" to 2-1/2", or two knots or knotholes or repairs 1" to 1-1/2".</li> </ol>

## Grade-use guide for construction and industrial plywood

	Use these symbols when you specify plywood (1) (2)	Description and Most Common Uses	Typical Grade-trademarks	Veneer Grade			Most Common Thickness (3) (Inch)							
				Face	Back	Inner Ply	1/4	5/16	3/8	1/2	5/8	3/4	7/8	1-1/8
<b>Interior Type</b>	STANDARD INT-DFPA (4)	Unsanded interior sheathing grade for floors, walls and roofs. Limited exposure crates, bins, containers and pallets.	STANDARD 32/16 INTERIOR 2-16-66	C	D	D		■	■	■	■	■	■	
	STANDARD INT-DFPA (4) (with Exterior glue)	Same as Standard sheathing but has Exterior glue. For construction where unusual moisture conditions may be encountered. Often used for pallets, crates, bins, etc. that may be exposed to the weather.	STANDARD 32/16 INTERIOR EXTERIOR GLUE 2-16-66	C	D	D		■	■	■	■	■	■	
	STRUCTURAL I and STRUCTURAL II INT-DFPA	Unsanded structural grades where plywood design properties are of maximum importance. Structural diaphragms, box beams, gusset plates, stressed skin panels. Also for containers, pallets, bins. Made only with Exterior glue. Structural I limited to Group 1 species for face, back and inner plys. Structural II permits Group 1, 2, or 3 species.	STRUCTURAL I 32/16 INTERIOR EXTERIOR GLUE 2-16-66	C	D	D								■
	UNDERLAYMENT INT-DFPA (4)	For underlayment or combination subfloor-underlayment under resilient floor coverings, carpeting. Used in homes, apartments, mobile homes, commercial buildings. Ply beneath face is C or better veneer. Sanded or touch-sanded as specified.	UNDERLAYMENT GROUP INTERIOR 2-16-66	Plugged C	D	C & D			■	■	■	■	■	
	C-D PLUGGED INT-DFPA (4)	For utility built-ins, backing for wall and ceiling tile. Not a substitute for Underlayment. Ply beneath face permits D grade veneer. Also for cable reels, walkways, separator boards. Unsanded or touch-sanded as specified.	C-D PLUGGED GROUP 2 INTERIOR 2-16-66	Plugged C	D	D			■	■	■	■	■	
	2-4-1 INT-DFPA (5)	Combination subfloor-underlayment. Quality base for resilient floor coverings, carpeting, wood strip flooring. Use 2-4-1 with Exterior glue in areas subject to excessive moisture. Unsanded or touch-sanded as specified.	2-4-1 GROUP 2 INTERIOR 2-16-66	Plugged C	D	C & D								■
<b>Exterior Type</b>	C-C EXT-DFPA (4)	Unsanded grade with waterproof bond for subflooring and roof decking, siding on service and farm buildings. Backing, crating, pallets, pallet bins, cable reels.	C-C 32/16 EXTERIOR 2-16-66	C	C	C		■	■	■	■	■	■	
	C-C PLUGGED EXT-DFPA (4)	Use as a base for resilient floors and tile backing where unusual moisture conditions exist. For refrigerated or controlled atmosphere rooms. Also for pallets, fruit pallet bins, reusable cargo containers, tanks and boxcar and truck floors and linings. Sanded or touch-sanded as specified.	C-C PLUGGED GROUP 4 EXTERIOR 2-16-66	Plugged C	C	C			■	■	■	■	■	
	STRUCTURAL I C-C EXT-DFPA	For engineered applications in construction and industry where full Exterior type panels made with all Group 1 woods are required. Unsanded.	STRUCTURAL I C-C EXTERIOR 2-16-66	C	C	C			■	■	■	■	■	
	PLYFORM CLASS I & II EXT-DFPA	Concrete form grades with high re-use factor. Sanded both sides. Edge-sealed and mill-glued unless otherwise specified. Special restrictions on species. Also available in HDO.	B-B PLYFORM CLASS I EXTERIOR 2-16-66	B	B	C					■	■		
<b>Notes:</b>			(1) All interior grades shown also available with Exterior glue.			(3) Panels are standard 4x8-foot size. Other sizes available.								
			(2) All grades except Plyform available tongue and grooved in panels 1/2", 5/8", 3/4", and 1-1/8".			(4) Available in Group 1, 2, 3 or 4.								
						(5) Available in Group 1, 2, or 3 only.								

### Typical Back-stamp

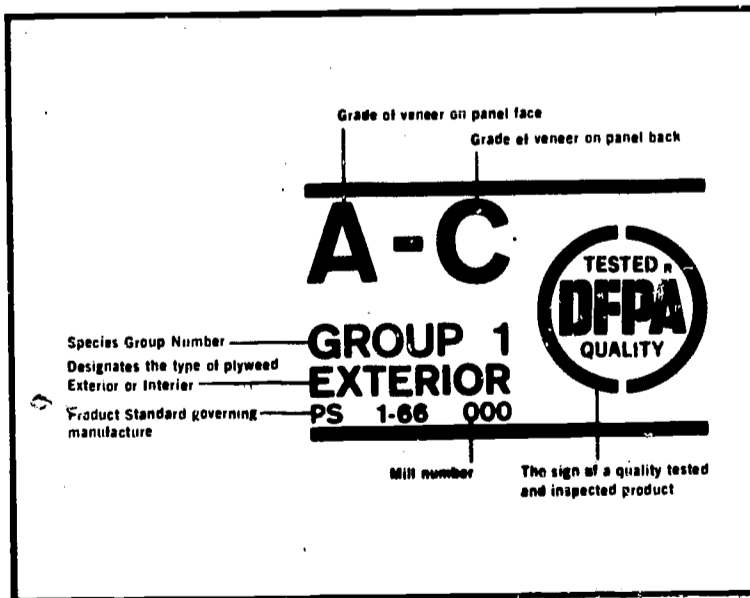

### Typical Edge-mark

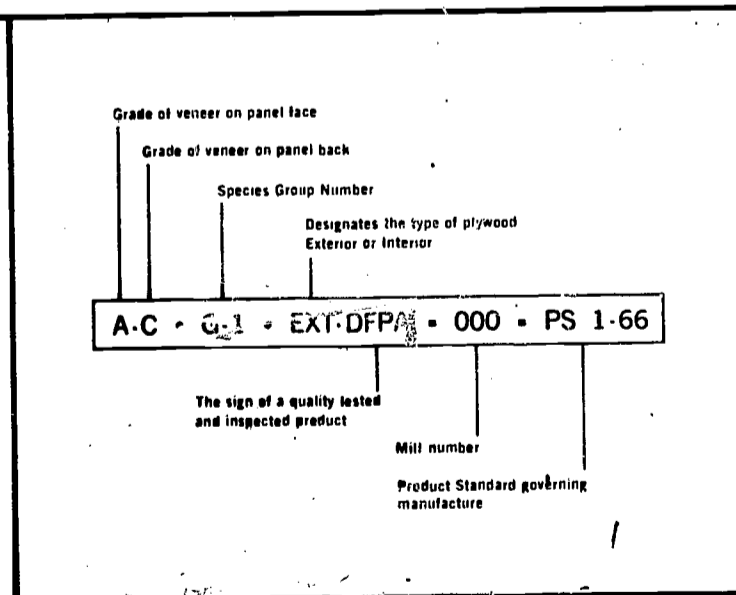

## CHAPTER VI

### MACERATED PRODUCTS

Macerated products are the latest sheet material to be developed in the lumber industry. The process was developed in Germany after World War II and has become the largest consumer of small logs and sawn lumber not suitable for dimension lumber. Material for this product consists of various kinds, sizes and shapes of wood chips when mixed with an adhesive, laid down in layers, pressed and cured make a product suited for the furniture and building industries. The companies manufacturing macerated materials have given the product many names, a few of the common names are, Flakeboard, Novoply, Chipboard, and Particle board. This material may be purchased in thicknesses of 1/4" to 1 1/2", widths of 48" and length of 96".

Another by-product of the lumber industry is hardboard. This product was accidentally discovered in 1924 and is similar to the product just mentioned but differs in that the cell structure is broken down into smaller particles. Sheets of this material are manufactured by the same methods used in making Flakeboard.

In 1926, when the first hardboard plant in the United States went into production, the total world out-put was less than six million board feet. Since then, the production of hardboard has increased steadily. Today the total world production is more than seven billion square feet. (In the hardboard industry a square foot is twelve inches long, twelve inches wide, and 1/8 of an inch thick.) Of this total, the United States produces more than 2.4 billion square feet (3:7).

## CHAPTER VII

### SUMMARY AND CONCLUSIONS

Marketing and grading of lumber products are complex and are difficult ones to be condensed in a paper of this size. The work reviewed is an attempt to summarize pertinent information that may be of benefit to those who are engaged in directing studies in Industrial Arts.

Those who have the responsibility of purchasing solid and sheet stock need to become as well versed as possible so that economy, quantity, and quality factors are kept in balance. Many times materials are purchased for the department through a business agent who knows little or nothing concerning the marketing and grading of hard and soft wood. If this kind of purchasing occurs it is expedient that the instructor enlighten the purchasing agent, in a subtle manner, that materials received are not of good quality. Invite those who are in charge of purchasing to check the shipment with you, using the information contained herein to establish controls. Instructors who deal directly with representatives of lumber products may avoid the problem just mentioned if he is up-to-date on grading problems.

The grading of materials is as equally important to the student in that he too is a consumer of products, and will continue to do so through his productive life. Instructors have an obligation to impart as much related and technical information as each learner can absorb. The information recorded herein, it is hoped, will be a guide that will be used and expanded by those engaging in pedagogy.

Those of us in the field of Industrial Arts are aware of the important contributions that are made by the department in the total picture of general education. We are also aware of the fact that wise use of leisure time is becoming more pronounced and the responsibility of utilizing this time, no doubt lies within our curriculum.

A conclusion that can be drawn at this juncture is that maybe the time is at hand for us to re-direct and

analyze the purposes of Industrial Arts. A shortened work week brought about by automation is changing our work oriented society to a leisure oriented society.

## BIBLIOGRAPHY

1. Brown, Nelson Courtland and James Samuel Bethel. Lumber. Second edition. New York: John Wiley & Sons Inc., 1958.
2. "Forest Industries," Portland, Oregon: Miller Freeman Publications, May 1968.
3. Gettle, Karl. "A Guide for the Study of the Manufacturing of Hardboard," Produced jointly by the American Hardboard Association and the American Industrial Arts Association.
4. Miller, Floyd. "How to Specify and Buy Industrial Arts Lumber and Plywood," A service publication of the Frank Paxton Lumber Co.
5. "The American Plywood Association," Form 66-470. National Bureau of Standards. December, 1966.
6. "Wood and Wood Products," Chicago, Illinois: Vance Business Publications, July, 1968.
7. "Rules for the Measurement and Inspection of Hardwood Lumber," Published by the National Hardwood Lumber Association. Chicago, Illinois: National Hardwood Lumber Association, 1956.
8. "Western Wood Products 1965 Standard Grading Rules," Portland, Oregon: Western Wood Products Association, 1965.



A SUGGESTED LABORATORY EXPERIENCE IN  
GRADING HARDWOODS

Purpose: To reinforce and build upon the skills in grading hardwoods previously covered in lectures and demonstrations.

Description of the Activity: Each student will grade the teacher selected hardwood so that he will have a basic knowledge of the procedure used in grading hardwood species.

Organization: (1) Divide the class into conveniently sized groups (three or four students to a group). (2) Assign each group a species of lumber to grade. Some groups may be able to handle more than one species but the idea is to divide the work load as evenly as possible. (3) Have only one group work on a given day to avoid crowding in the lumber area. (4) Teacher evaluation of exercise.

Materials: Hardwood boards of different grades and species.

A SUGGESTED LABORATORY EXPERIENCE IN  
FIGURING BOARD FEET

**Purpose:** To reinforce and build upon the skills of computing board feet previously taught in a lecture - demonstration.

**Description of the Activity:** Students in a woodworking class can measure the board footage of the lumber in the shop.

**Organization:** (1) Divide the class into conveniently sized groups (three or four students to a group). (2) Assign each group a species of lumber to measure. Some groups may be able to handle more than one species but the idea is to divide the work load as evenly as possible. (3) Have only one group work on a given day to avoid crowding in the lumber area. (4) Tally sheets for each species should be issued to the teams. (See Handout) (5) Give the teams as many days as is necessary to complete their tally.

**Materials, Tools and Equipment:** Rulers or lumber tally sticks if available and some means of measuring the length of the lumber. (A one by two by sixteen marked into one foot units will do nicely.)

<b>TALLY SHEET</b>				
<b>THICKNESS</b> _____		<b>SPECIES</b> _____		
<b>Footage Per Bd.</b>	<b>Pieces</b>	<b>Total Pieces</b>	<b>Total Feet</b>	<b>App.</b>
1				
2				
3				
4				
5				
6				
7				
8				
9				
10				
11				
12				
<b>TOTAL</b>				

**Table 38. International Log Rule, Board Feet**  
(Saw kerf  $\frac{1}{4}$  in.) \*

Top diameter, i.b. (in.)	Length of log in feet						
	8	10	12	14	16	18	20
4		5	5	5	5	5	10
5	5	5	10	10	10	15	15
6	10	10	15	15	20	25	25
7	10	15	20	25	30	35	40
8	15	20	25	35	40	45	50
9	20	30	35	45	50	60	70
10	30	35	45	55	65	75	85
11	35	45	55	70	80	95	105
12	45	55	70	85	95	110	125
13	55	70	85	100	115	135	150
14	65	80	100	115	135	155	175
15	75	95	115	135	160	180	205
16	85	110	130	155	180	205	235
17	95	125	150	180	205	235	265
18	110	140	170	200	230	265	300
19	125	155	190	225	260	300	335
20	135	175	210	250	290	330	370
21	155	195	235	280	320	365	410
22	170	215	260	305	355	405	455
23	185	235	285	335	390	445	495
24	205	255	310	370	425	485	545
25	220	280	340	400	460	525	590
26	240	305	370	435	500	570	640
27	260	330	400	470	540	615	690
28	280	355	430	510	585	665	745
29	305	385	465	545	630	715	800
30	325	410	495	585	675	765	860
31	350	440	530	625	720	820	915
32	375	470	570	670	770	875	980
33	400	500	605	715	820	930	1,045
34	425	535	645	760	875	990	1,110
35	450	565	685	805	925	1,050	1,175
36	475	600	725	855	980	1,115	1,245
37	505	635	770	905	1,040	1,175	1,315
38	535	670	810	955	1,095	1,245	1,390
39	565	710	855	1,005	1,155	1,310	1,465
40	595	750	900	1,060	1,220	1,380	1,540
41	625	785	950	1,115	1,280	1,450	1,620
42	655	825	995	1,170	1,345	1,525	1,705
43	690	870	1,045	1,230	1,410	1,600	1,785
44	725	910	1,095	1,290	1,480	1,675	1,870
45	755	955	1,150	1,350	1,550	1,755	1,960
46	795	995	1,200	1,410	1,620	1,835	2,050
47	830	1,040	1,255	1,475	1,695	1,915	2,140
48	865	1,090	1,310	1,540	1,770	2,000	2,235
49	905	1,135	1,370	1,605	1,845	2,085	2,330
50	940	1,185	1,425	1,675	1,920	2,175	2,425
51	980	1,235	1,485	1,745	2,000	2,265	2,525
52	1,020	1,285	1,545	1,815	2,080	2,355	2,625
53	1,060	1,335	1,605	1,885	2,165	2,445	2,730
54	1,100	1,385	1,670	1,960	2,245	2,540	2,835
55	1,145	1,440	1,735	2,035	2,330	2,640	2,945
56	1,190	1,495	1,800	2,110	2,420	2,735	3,050
57	1,230	1,550	1,865	2,185	2,510	2,835	3,165
58	1,275	1,605	1,930	2,265	2,600	2,935	3,275
59	1,320	1,660	2,000	2,345	2,690	3,040	3,390
60	1,370	1,720	2,070	2,425	2,785	3,145	3,510

# STANDARD HARDWOOD GRADES F.A.S.

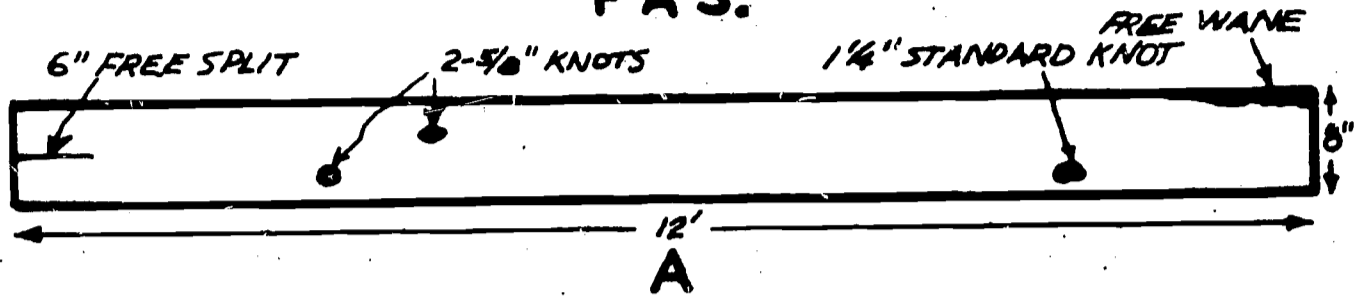

## SELECT

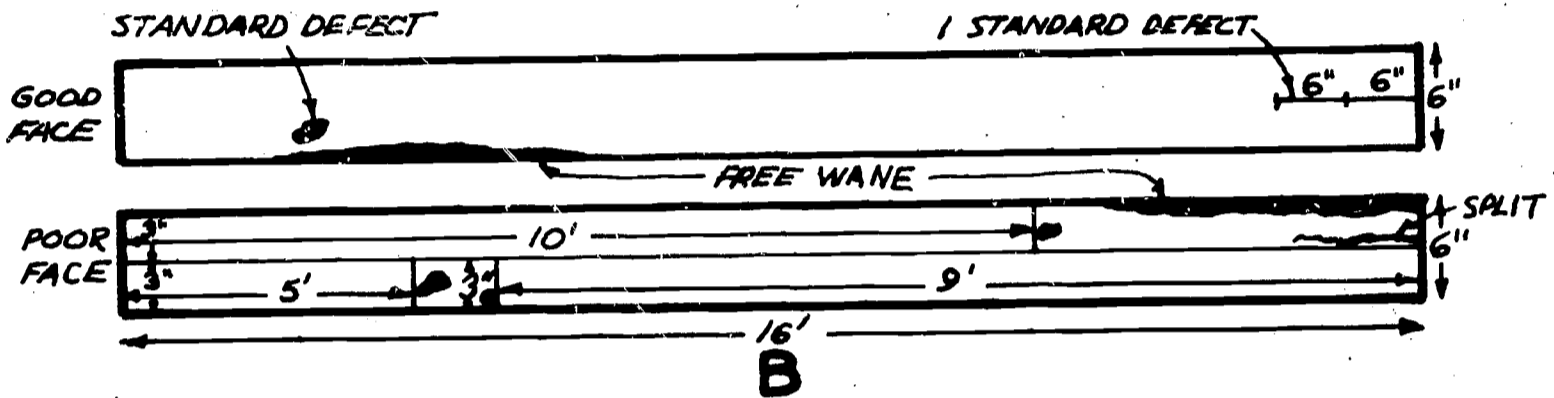

## №1 COMMON

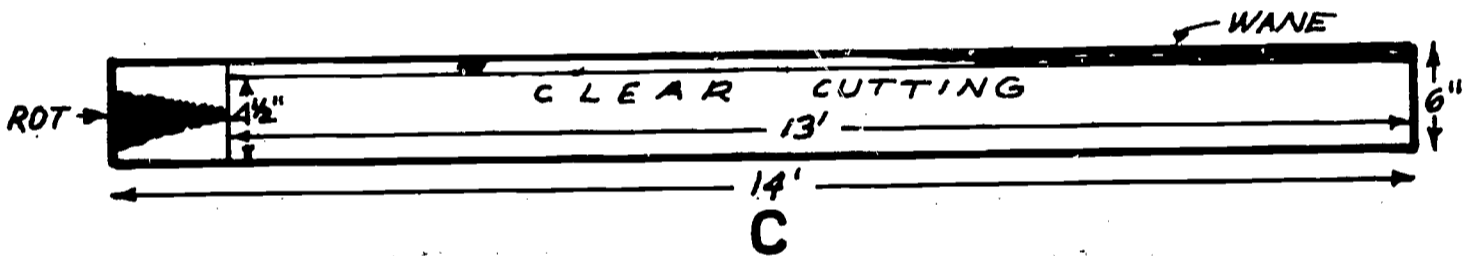

## №2 COMMON

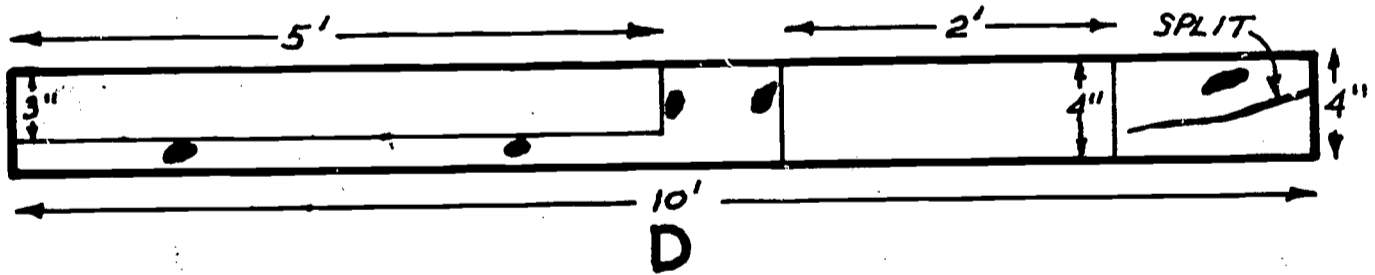

## №3 COMMON

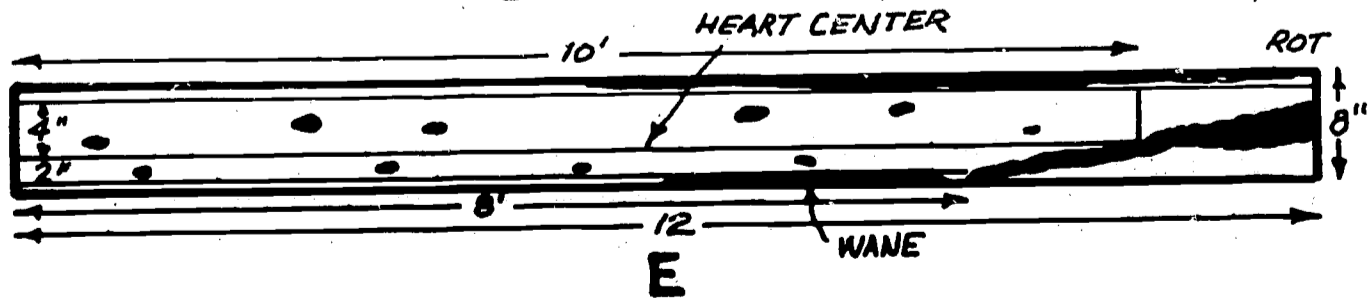

NOTE: REFER TO CHAPTER III

# SOFTWOOD (YARD LUMBER)

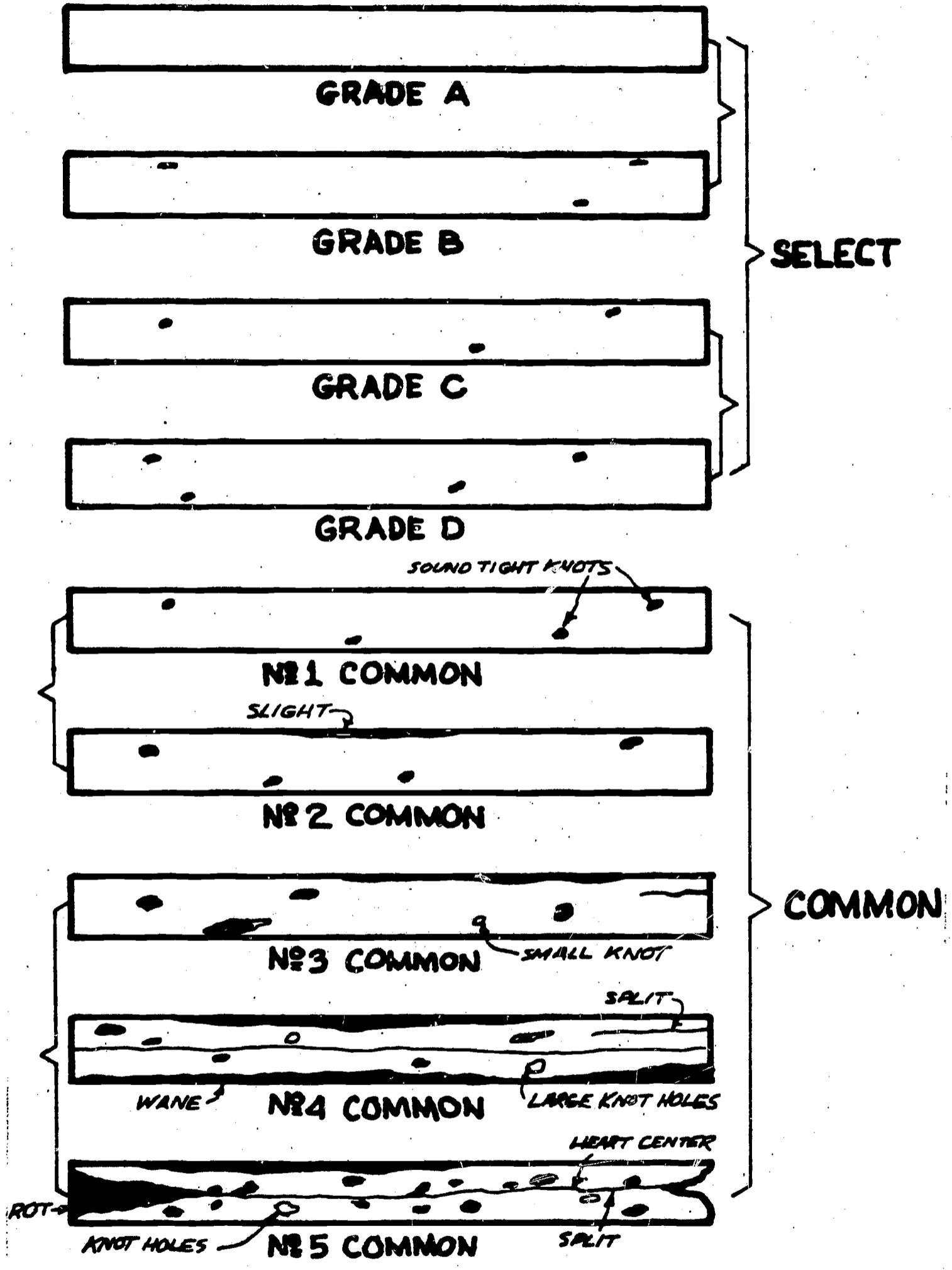

NOTE: REFER TO CHAPTER IV

### NOMOGRAPH SCALE

To use the nomograph scale place a straight edge on the appropriate thickness and width in the left column and on the correct length in the right hand column. The reading on the center column is the number of board feet.

(School Shop, Oct. 1966)

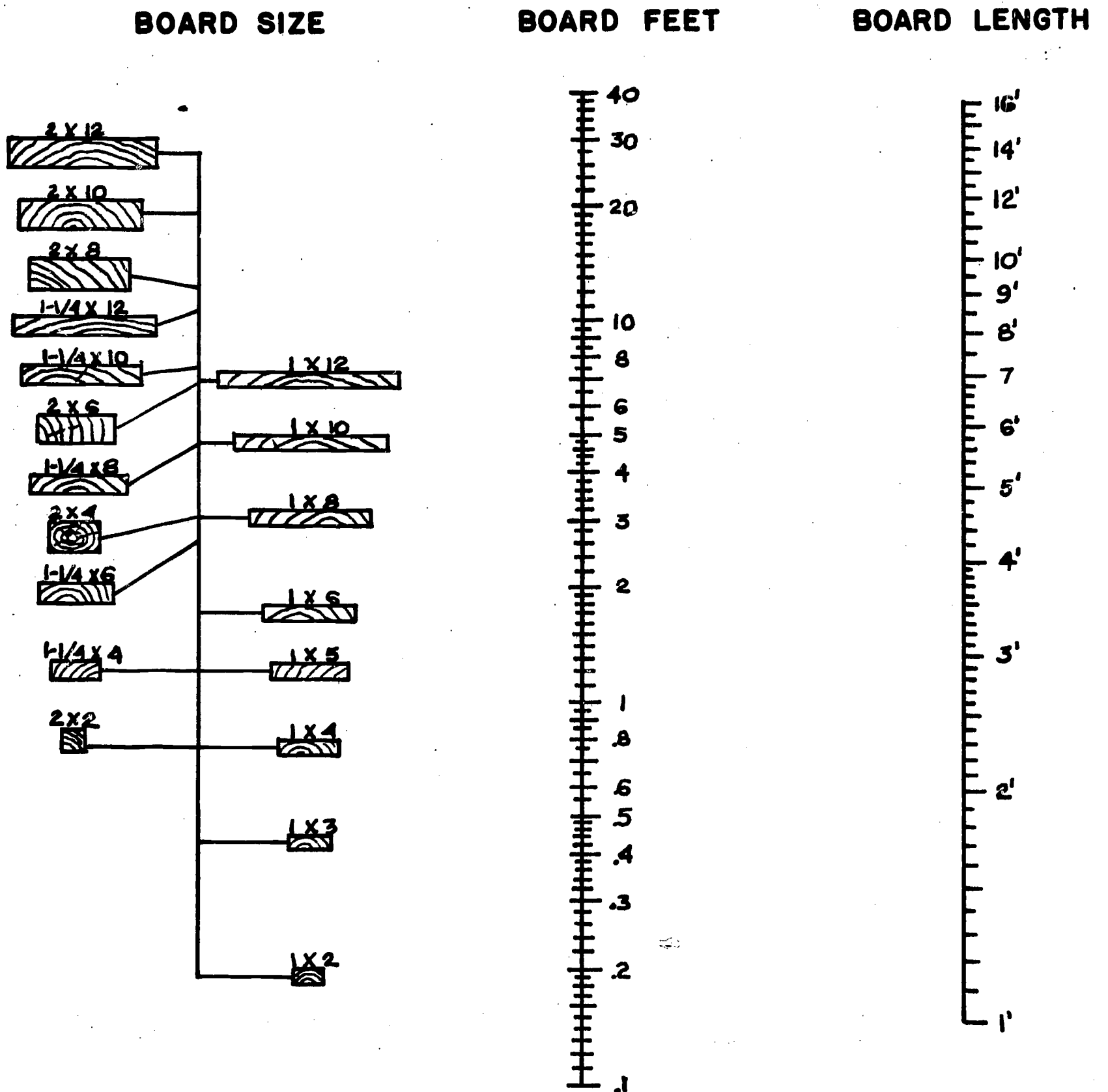

## TEACHING CONVERSION FACTORS FOR CONVERTING

## LINEAL FEET TO BOARD FEET

Select width of board and read horizontally to column representing thickness. Intersection of known thickness and width will give conversion factor which should be multiplied by lineal footage to obtain B.F.

Width	Thickness												
	1"	1-1/4"	1-1/2"	2"	2-1/2"	3"	3-1/2"	4"	5"	6"	8"	10"	12"
1"	.083	.104											
2	.167	.208	.250	.333									
3	.250	.313	.375	.500	.625	.750							
4	.333	.417	.500	.667	.833	1.000	1.167	1.334					
5	.417	.521	.625	.833	1.042	1.250	1.458	1.667	2.083				
6	.500	.625	.750	1.000	1.250	1.500	1.750	2.000	2.500	3.000			
7	.583	.729	.875	1.167	1.458	1.750	2.042	2.334	2.917	3.500			
8	.667	.833	1.000	1.333	1.667	2.000	2.334	2.667	3.334	4.000	5.334		
9	.750	.945	1.125	1.500	1.875	2.250	2.625	3.000	3.750	4.500	6.000		
10	.833	1.042	1.250	1.667	2.083	2.500	2.917	3.334	4.167	5.000	6.667	8.333	
11	.917	1.153	1.375	1.833	2.292	2.750	3.208	3.667	4.583	5.500	7.334	9.167	
12	1.000	1.250	1.500	2.000	2.500	3.000	3.500	4.000	5.000	6.000	8.000	10.000	12.000
13	1.083	1.361	1.625	2.167	2.708	3.250	3.792	4.334	5.417	6.500	8.667	10.833	13.000
14	1.167	1.458	1.750	2.333	2.917	3.500	4.083	4.667	5.834	7.000	9.334	11.667	14.000
15	1.250	1.562	1.875	2.500	3.125	3.750	4.375	5.000	6.250	7.500	10.000	12.500	15.000
16	1.333	1.667	2.000	2.667	3.334	4.000	4.667	5.334	6.667	8.000	10.667	13.333	16.000
17	1.417	1.771	2.125	2.833	3.542	4.250	4.958	5.667	7.083	8.500	11.333	14.167	17.000
18	1.500	1.875	2.250	3.000	3.750	4.500	5.250	6.000	7.500	9.000	12.000	15.000	18.000
19	1.583	1.979	2.375	3.167	3.958	4.750	5.542	6.334	7.917	9.500	12.667		
20	1.667	2.083	2.500	3.334	4.167	5.000	5.834	6.667	8.334	10.000	13.333		
21	1.750	2.188	2.625	3.500	4.375	5.250	6.125	7.000	8.750	10.500	14.000		
22	1.833	2.292	2.750	3.667	4.583	5.500	6.417	7.334	9.167	11.000	14.667		
23	1.916	2.996	2.875	3.834	4.792	5.750	6.708	7.667	9.583	11.500	15.333		
24	2.000	2.500	3.000	4.000	5.000	6.000	7.000	8.000	10.000	12.000	16.000		
25	2.083	2.604	3.125	4.167	5.208	6.250	7.292	8.334	10.417	12.500	16.667		
26	2.167	2.708	3.250	4.334	5.417	6.500	7.583	8.667	10.833	13.000	17.333		
27	2.250	2.813	3.375	4.500	5.625	6.750	7.875	9.000	11.250	13.500	18.000		
28	2.334	2.917	3.500	4.667	5.834	7.000	8.167	9.334	11.667	14.000	18.667		
29	2.417	3.021	3.625	4.834	6.042	7.250	8.458	9.667	12.083	14.500	19.333		
30	2.500	3.125	3.750	5.000	6.250	7.500	8.750	10.000	12.500	15.000	20.000		



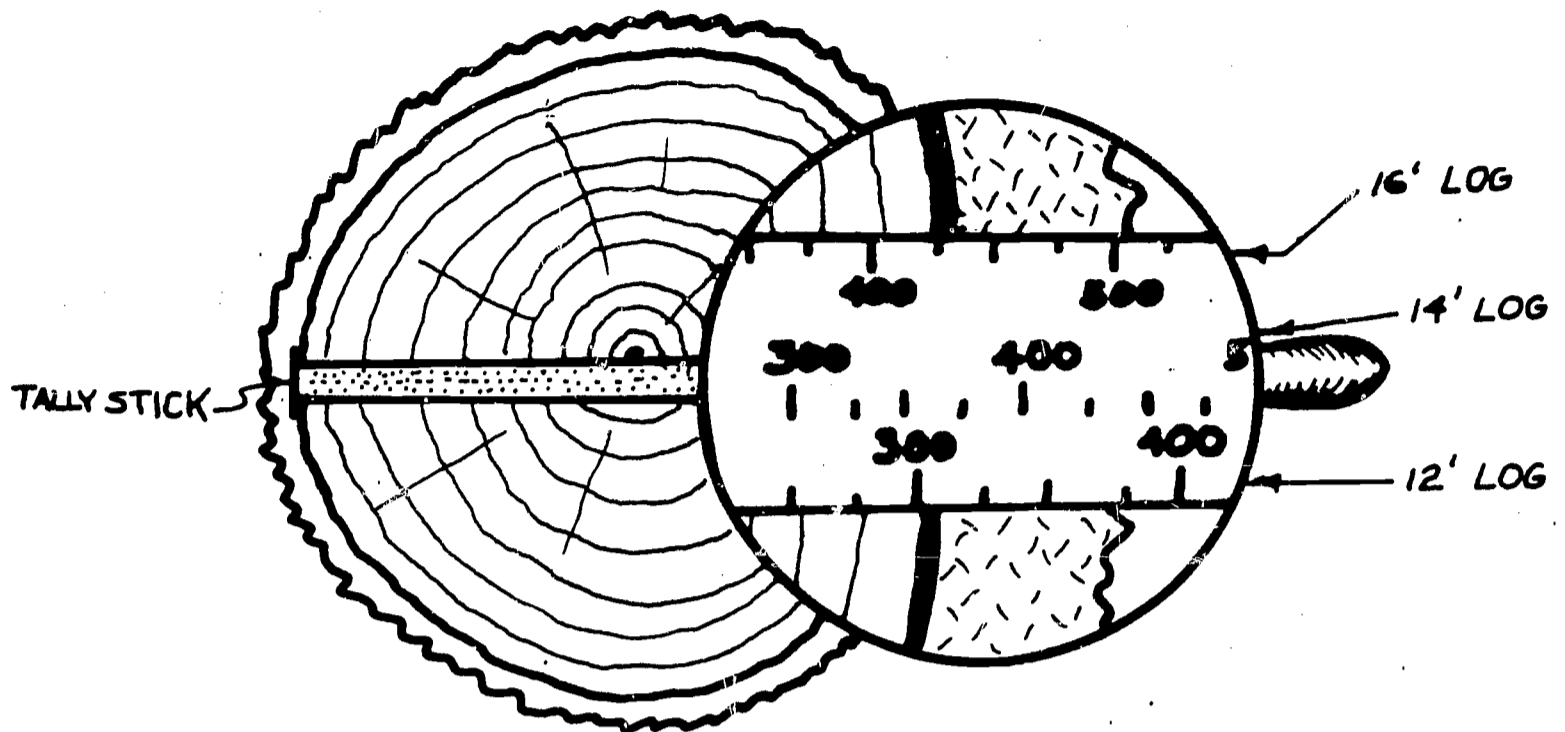

## USE OF LOG TALLY STICK

Lumber Tally Stick. (See Fig. 2) Tally sticks used in Lumber measure are not the same as those used in measuring logs. A lumber tally stick is also marked in specific lengths of 12', 14', and 16' on one side and 8', 10', and 18' on the other, but the tally indicates the number of board feet in one inch stock. By doubling or halving the length on the tally stick, the scaler can readily figure the board footage of all the commonly used lengths of Lumber.

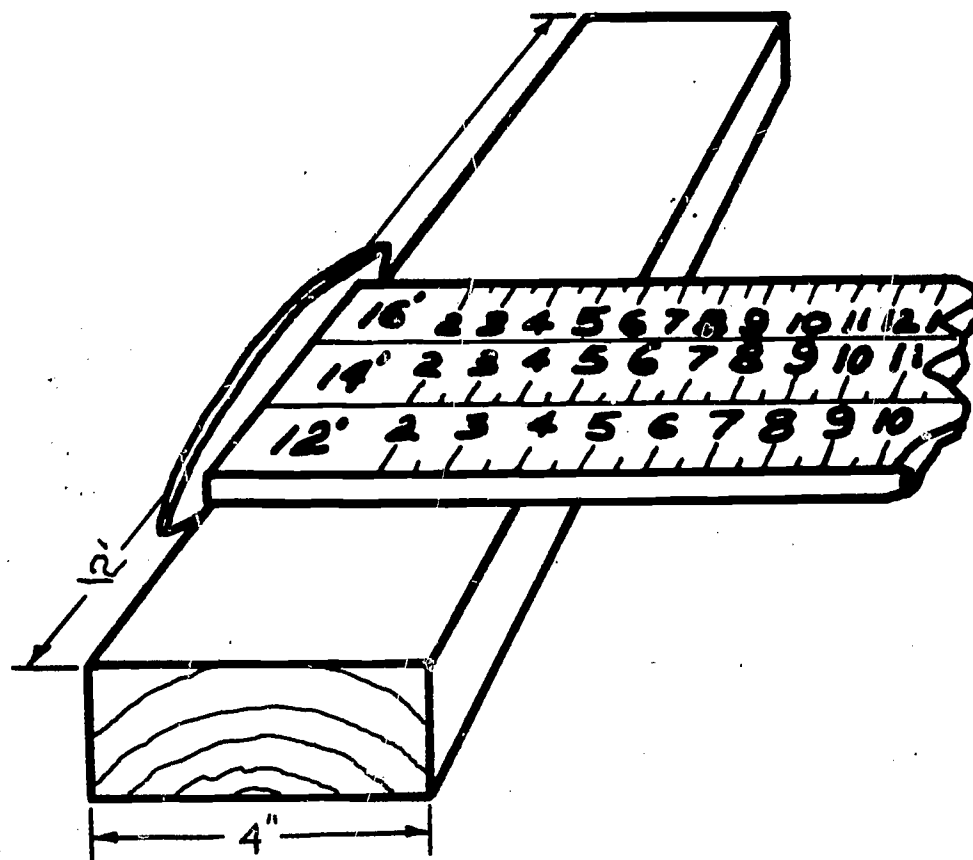

## USE OF LUMBER TALLY STICK

Lumber Tally Stick. (See Fig. 1) The scaler in the forest or sawmill generally does not use a chart such as chart No. 38. He uses a tally stick which gives the same reading as the log scale rule but it is faster to use and better adapted to the conditions under which a scaler works. The tally stick is placed on the top end of the log with the edge of the tally stick running thru the pith. The top of the tally stick is held even with the left hand surface of the log. On a twelve foot log follow the line of numbers extending to the right of the twelve foot mark on the tally stick; the dot number that falls on the edge of the log indicates the board foot measure. One side of the tally is marked for 12', 14', and 16' lengths; the other side of the tally stick is marked for 8', 10', and 18' lengths.

A TEACHING UNIT IN PHYSICAL TESTING  
OF JOINTS, FINISHES, ADHESIVES  
AND FASTENERS

---

Presented to

Dr. Hammer

Mr. Marsters

Mr. Evans

---

In Partial Fulfillment  
of the Requirements for the Course  
Industrial Arts 298

---

by

Ray M. Davis

A. D. Williams

William Foltz

Stanley Johnson

July 1968

## TABLE OF CONTENTS

	PAGE
I. INTRODUCTION . . . . .	1
II. GUIDELINES FOR STUDENT ACTIVITIES . . . . .	1-2
III. SUGGESTED PHYSICAL TESTS . . . . .	2-4
IV. STRENGTH COMPARISONS OF FOUR COMMON EDGE JOINTS . . . . .	4
Statement of the Problem . . . . .	4
Suggested Equipment and Procedure . . . . .	4-5
Job Sheet on Basic Joint Construction . . . . .	6
Test Apparatus and Jigs . . . . .	7
Recording Data Sheet . . . . .	8
V. PHYSICAL TESTS OF FINISHES . . . . .	9
Statement of the Problem . . . . .	9
Suggested Equipment and Procedure . . . . .	9
Conclusions . . . . .	11
Recording Data Sheet . . . . .	12
Abrasive Tester . . . . .	13
VI. HOLDING POWER OF WOOD ADHESIVES . . . . .	14
Statement of the Problem . . . . .	14-15
Suggested Equipment and Procedure . . . . .	15
Wood Splitting Apparatus . . . . .	15
Recording Data Sheet . . . . .	17
VII. VALIDATING THE COMMON WOOD SCREW CHART . . . . .	19
Statement of the Problem . . . . .	19
Mechanical Properties of Wood . . . . .	19-20

PAGE

Suggested Student Procedure . . . . . 20-21

Layout of Test Sample . . . . . 22

Typical Screw Hole Chart . . . . . 23

Question and Answer Sheet . . . . . 24-25

Recording Data Sheet . . . . . 26

VIII. TEST APPARATUS . . . . . 27-29

BIBLIOGRAPHY . . . . . 30

## TECHNICAL INFORMATION

Contemporary Industrial Arts leaders are emphasizing new approaches to learning about our complex industrial world of today (1:13-26). Among the various new approaches is the concept of research and experimentation. This concept involves the testing or comparing of industrial supplies and materials. Perhaps you have heard some of these frequently asked questions in the Industrial Arts shop: What size pilot hole do I use for a Number 8 screw? What type of joint should I use for a drawer? What finish should I use for a coffee table, or which glue should I use for my water skis? Do we have to resort to traditional methods to answer these questions directly for each individual, or should we lecture to a group about these things? Perhaps we could suggest that the students devise a system for discovering (or re-discovering) some facts for themselves. Here is where a "new" approach might ascertain answers for such questions.

This teaching unit is designed to introduce students to research and experimentation techniques as an important industrial process. The implementation of these techniques should lead students to investigate and find for themselves answers to the questions mentioned above and many, many more. Perhaps a new skill, the skill of resourcefulness, will be developed in our students as an outcome(1:94-95).

## GUIDELINES FOR STUDENT ACTIVITY

There are some important guidelines to consider as the students attempt to use research and experimentation as a modern approach for learning.

1. Define the problem - Just what am I attempting to find out? Make a list of assumptions regarding the problem, ie., polyvinyl is the best all-around adhesive for woodworking, this is simply an assumption and may or may not prove to be true.
2. Study available resources such as technical books, articles and encyclopedias.
3. Keep accurate records, notes, etc. of materials read and results of tests and experiments. Usually an instrument for recording information of lab experiences (data sheet, lab report, etc.) can be devised which will present finding in an orderly manner.
4. Note any precautions to be taken, such as unsafe procedures, dangerous chemicals, etc. and act accordingly.
5. Check to see that all materials are available, and construct or modify test apparatus so you are sure test can be conducted

with available facilities. Keep tests and test apparatus as simple as possible.

6. Develop accurate techniques for testing so validity is high.
7. Do not expect all results to come out as you assumed they would. Tests are only valid after they have been carefully repeated many times and averages taken.

#### SUGGESTED PHYSICAL TESTS ON MATERIALS USED IN THE WOODWORKING INDUSTRY

The accompanying lab experiences have been designed as samples of what can be done in woodworking shops. A list of many more tests and problems are included, and no doubt as many more can be thought of by an enterprising instructor or his students.

#### Tests Made on Wood

1. Bending properties - Breaking characteristics and bending radius.
2. Bending (impact)
3. Compression parallel to the grain
4. Compression perpendicular to the grain
5. Cleavage perpendicular to the grain
6. Hardness
7. Heartwood and sapwood relative strengths
8. Fire resistance
9. Freezing and its effect on the strength of wood
10. Fasteners - Withdrawal resistance and strength factors
11. Moisture content - Its relation to strength and bending characteristics
12. Moisture absorption ability
13. Machinability
14. Shrinkage - Radial and tangential
15. Shrinkage in relation to moisture content
16. Strength reducing factors
17. Shear parallel to the grain
18. Tension parallel to the grain
19. Tension perpendicular to the grain
20. Toughness
21. Weights of various species
22. Warpage characteristics of various species
23. Variation of species regarding any of the above tests

#### Tests Made on Woodlike Materials - (hardboard, particleboard, fiberboard and plasterboard).

1. Abrasion resistance

2. Compression strength
3. Effect of moisture
4. Fire resistance
5. Hardness
6. Holding power of fasteners
7. Impact resistance
8. Machinability of material
9. Static bending
10. Strength (shear)
11. Strength (tensile)
12. Water absorption ability

#### Tests on Plywood

1. Breaking radius
2. Causes of delamination
3. Edgewise compressive strength
4. Effect of odd number of plies
5. Exposure ability
6. Flatwise compressive strength
7. Flexure tests
8. Glue shear
9. Shear test
10. Static bending
11. Tension test

#### Structure of Assemblies

1. Strength of various joints
2. Strength of trusses
3. Resistance of different bracing to cabinet warpage
4. Strength of built up members (nailed or box beams)
5. Strength of laminated members
6. Nailing methods - relative strength of different methods such as toenailing and clinching

#### Abrasives

1. Cutting ability - various grits and materials
2. Durability of various abrasives
3. Durability of various backings
4. Reaction to moisture

#### Fasteners - Screws, nails, corrugated fasteners, staples and chevrons

1. Nail withdrawal - may include various shank types
2. Screw withdrawal and/or holding power
3. Holding power of wall fasteners
4. Nails - toenailed holding power
5. Nails - clinched holding power
6. Nails - relationship of head type to holding power



7. Nails - spacing effect on holding power
8. Nails - direction of nailing on holding power
9. Nails - effect of point type withdrawal
10. Pilot holes - proper size on holding power of screws
11. Splitting of materials caused by fasteners (in hardwoods, softwoods and plywood)

### Adhesives

1. Adhesion qualities
2. Effect of cold
3. Resistance to chemicals
4. Flexural tests
5. Effect of heat
6. Strength - impact
7. Strength - shear test
8. Strength - wood to various materials (metal and plastic)
9. Strength - tensile test
10. Strength - peel or stripping test
11. Effect of moisture on strength

### STRENGTH COMPARISONS OF FOUR COMMON EDGE JOINTS (Non-Reinforced Joints)

There is no doubt that some types of wood joints are far superior to others in a specific application. The strength of a joint is one factor in deciding which joint to use. Other factors might be appearance (aesthetic value), economic feasibility of making a particular joint, and the usage or stresses to which the object might be subjected. We will concern ourselves with the strength factor of a woodworking joint and how it compares with the strength of other joints in the same application. This laboratory test is designed to let students discover for themselves the answers to some of the problems of joint selection.

#### STATEMENT OF THE PROBLEM

To determine the relative strength of four different edge joints (or the force it takes to collapse them) commonly used in box construction, cabinet construction and drawer construction.

#### SUGGESTED EQUIPMENT AND PROCEDURE

**Materials:** Sixteen  $3/4 \times 2 \ 1/2 \times 4$ " pieces of clear straight-grained wood (any species you wish to test for construction of joints). All pieces should come from the same board, thereby keeping all char-

acteristics of the joint as nearly alike as possible. The adhesive used should be the one which would normally be used in the actual project in which the joint(s) would be used.

Tools and Equipment: Shop made laboratory press. (Note: Other excellent test equipment and/or devices may be found in books and periodicals listed in the bibliography).

Procedure:

1. Construct at least two of each of the four joints shown on the job sheet on page . Follow the directions closely so strongest possible joints will result. The use of a clamping jig such as the one shown on page 7 will aid in construction of uniform joints.
2. Set up test apparatus using spreader block and pressure pad as illustrated on page 7 , Fig. 1.
3. Apply pressure slowly and evenly to specimen until failure of joint occurs.
4. Record pressure reading at time of failure on data sheet in the proper column.
5. Repeat on each of the joints. Record all results on the data sheet.
6. Be sure all data is recorded as indicated on data sheet, then record average pressure required for joint failure and compare to see which joint was the strongest.

Precautions: This is a relatively safe test procedure, but students should be advised to keep their hands away from moving parts during the actual test.

Findings: The average of the failure readings will give a relative strength indication of a particular type of joint. There are several factors which could alter the validity of the results so it is of utmost importance that all processes be conducted with absolute uniformity. An accurate record should be compiled of all tests conducted by students thereby increasing the validity of the results. Note: (Students may wish to deliberately alter certain factors such as clamping time, type of adhesive used, etc. This should be encouraged, but it must be remembered that the results cannot be compared indiscriminately with other test results). The lower half of the data sheet may be used to record data taken from altered test specimens.

$\frac{1}{4} \times \frac{1}{2}$  RABBET JOINT

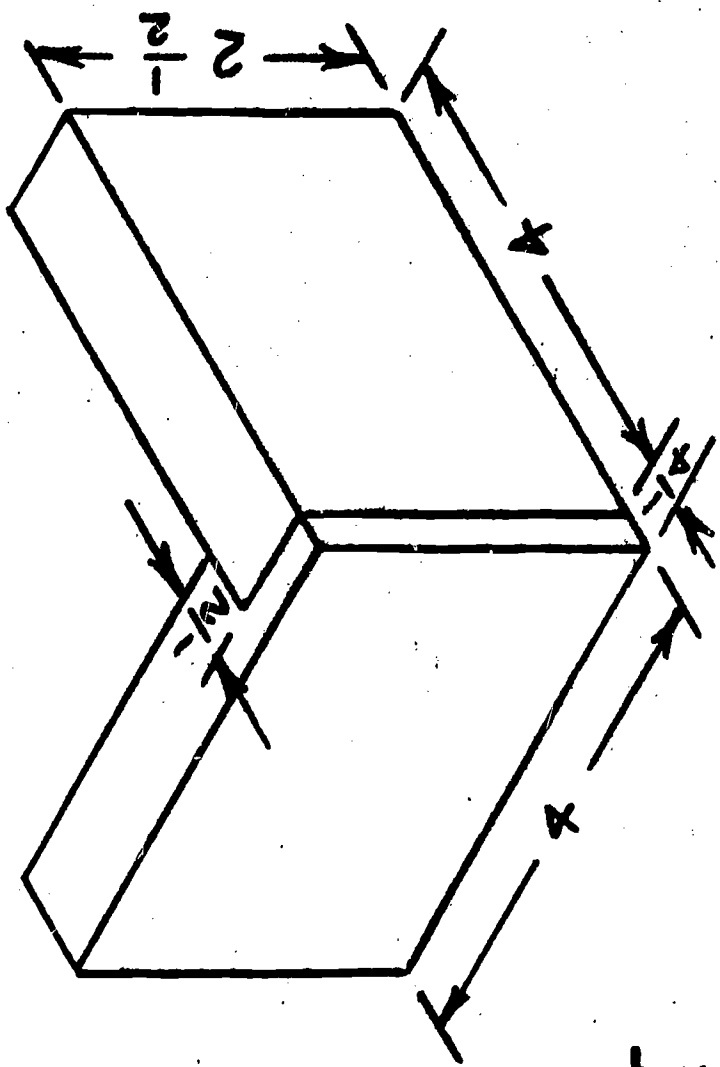

DADO + TONGUE JOINT

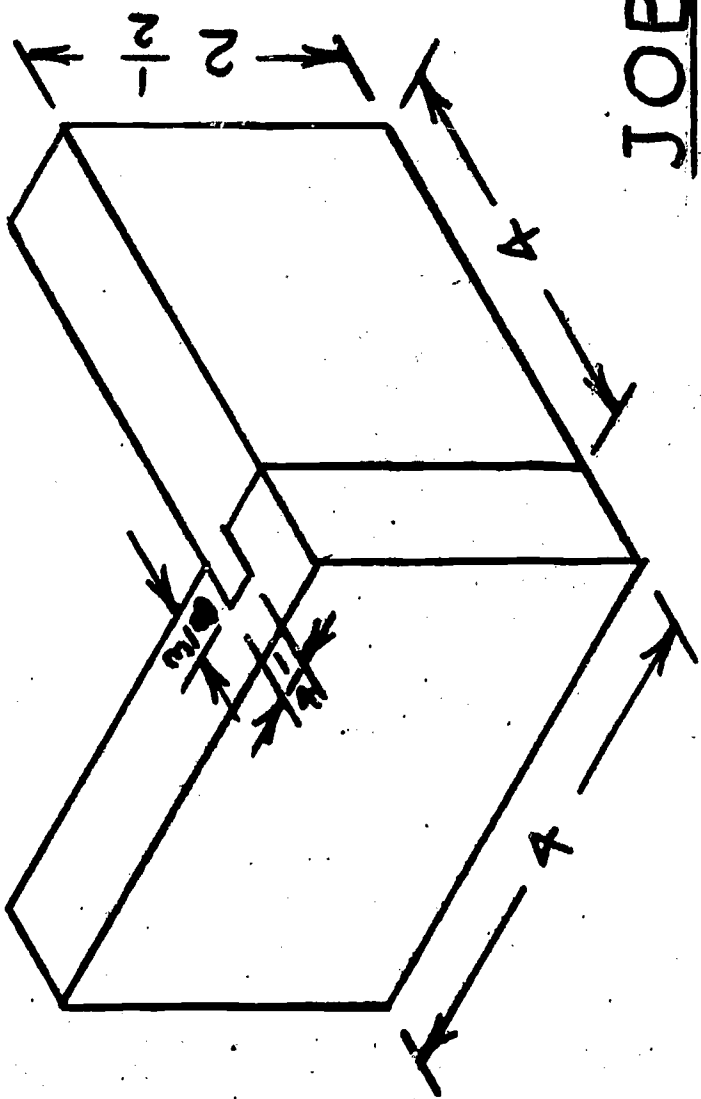

JOB SHEET

BASIC JOINT CONSTRUCTION FOR  
PHYSICAL TESTS

SCALE:  $\frac{1}{2}'' = 1'$

SPLINED MITER JOINT

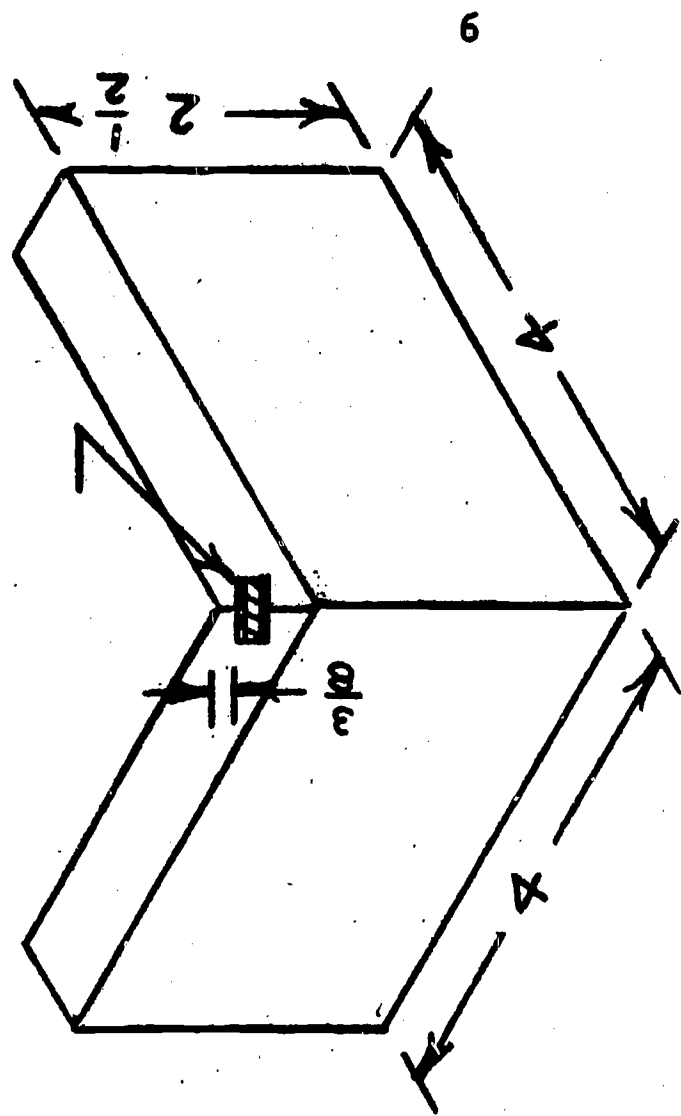

BUTT JOINT

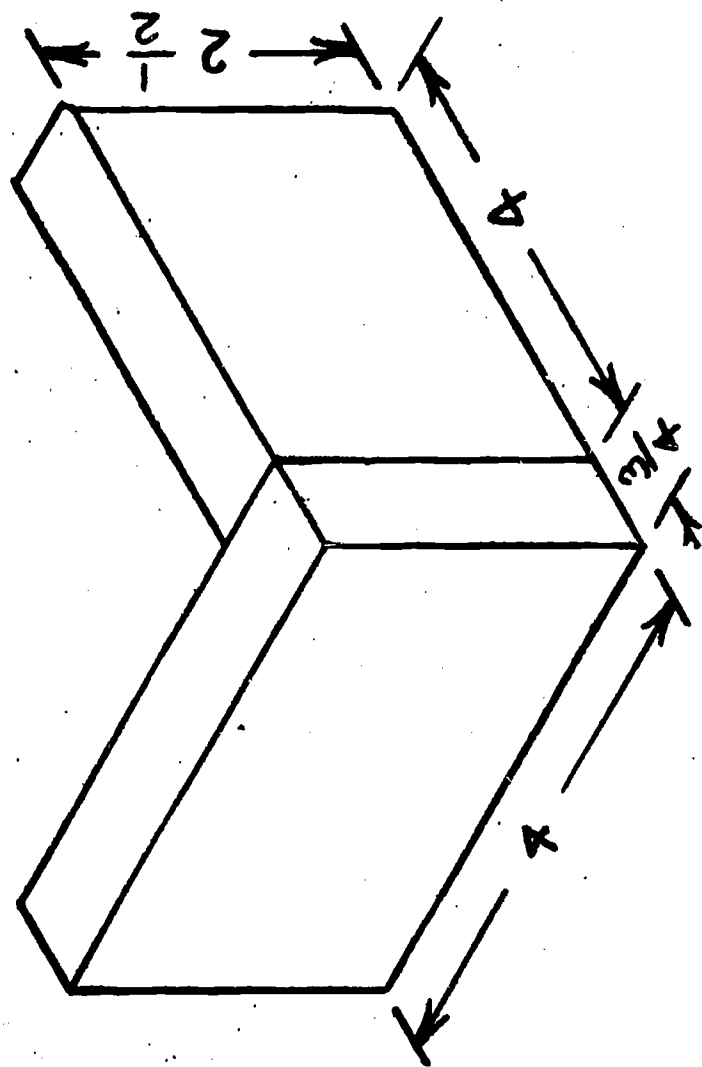

Fig. 1 - Details of pressure pad and spreader to be used with laboratory press.

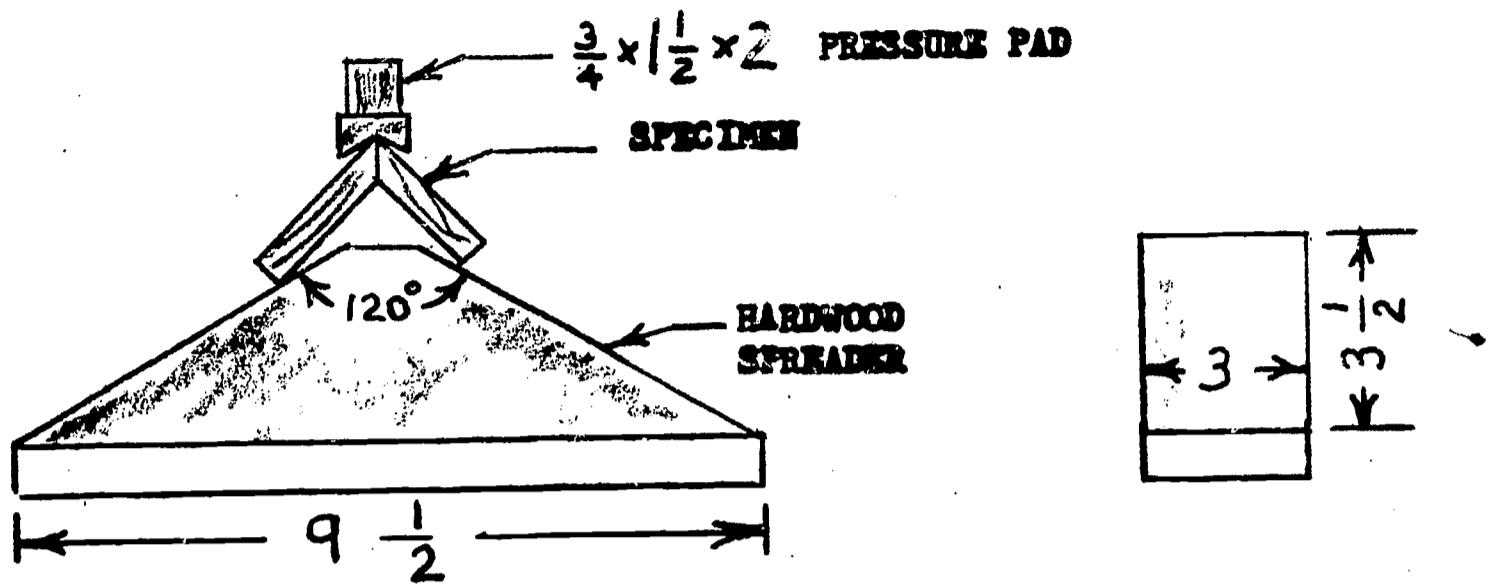
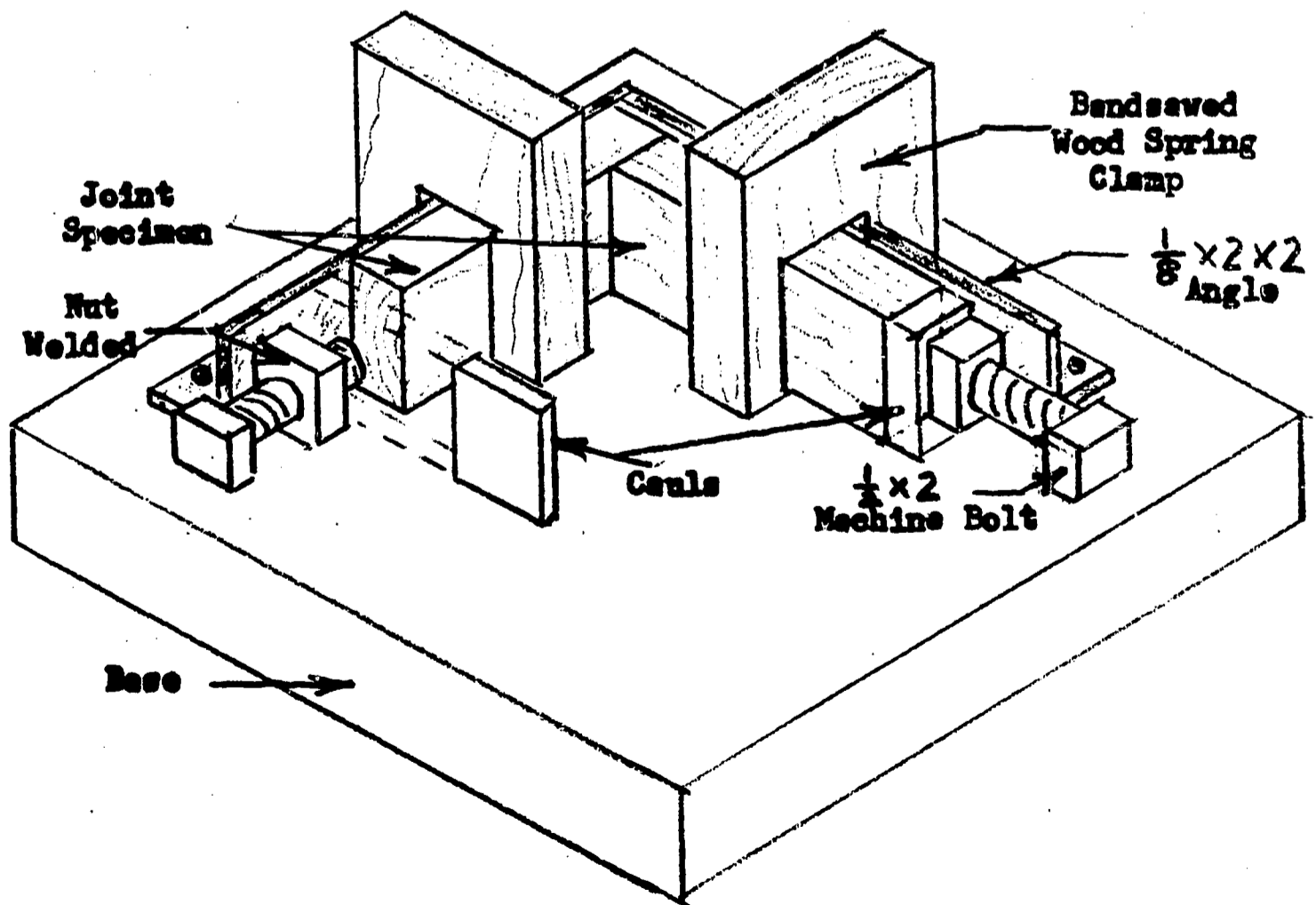

Fig. 2 - Sample gluing jig for joint specimens.



**RECORDING DATA SHEET**  
**Strength Comparison of Joints**

	Type of Joint	Species of Wood	Weight (Gr)	M.C. %	Force Required For Failure	Average Force
I	A					
	B					
II	A					
	B					
III	A					
	B					
IV	A					
	B					
V	A					
	B					

Note: Use the space below if joints being tested are to be altered. Indicate special treatment under first column.

I	A					
	B					
II	A					
	B					
III	A					
	B					
IV	A					
	B					

## STATEMENT OF THE PROBLEM

Selecting the correct finish for a project is often a difficult task for a student. The final selection is often made by chance with little thought on which finish will best suit his needs. In the following tests we outline a program by which the individual may better judge the relative merits of various finishes. The best finish, from wearing qualities standpoint, may not be the ultimate decision he must make. How the furniture will be used, the finish that will be the most attractive, the style, existing furniture and weather conditions may well dictate the final choice.

The controlled testing program will simulate a number of conditions found around the home. Finishes used will be those normally found in schools or readily available in various type supply stores. Uniformity of tests for each material will be stressed.

## SUGGESTED EQUIPMENT AND PROCEDURE

Walnut blocks 3" x 6" x 1/2" are the subjects of the tests. Other woods could be substituted if desired. Walnut was chosen because of its good grain pattern, its popularity in fine furniture, and hardwood qualities.

Preparation of the blocks should be done three or four days in advance of the tests to allow the finishes to dry. The blocks should be surfaced sanded prior to the application of the various finishes and between coats. No stains or fillers should be used. Manufacturers suggestions on application of various finishes should be stressed. Oil and wax finishes are not sanded between coats. For the best results, blocks probably should come from the same piece of wood.

Labels should be placed on the reverse side of each block to help in identification. The same label and finish should be placed on seven different blocks to run the test series.

Finishes to be applied to the front surfaces of the blocks:

1. Danish Oil (Watco)
2. Linseed Oil
3. Wax (Trewax)
4. Varnish (Mar-Not, Sherwin-Williams)
5. Deft
6. Clear Lacquer
7. Varithane (Flecto)

The above name brands are suggestions and can be varied according to stock available. Additional materials may also be added.

The following tests should be performed on a block with each of the finishes to be tested:

1. Heat Test - Student places a glass of hot boiling water on the surface of a block. (To simulate hot coffee or other hot liquid). Let water cool and note result on surface of block. Repeat test with each finishing material. Rate each finishing material on a one, two, three, etc. basis.
2. Alcohol Test - Student places a good grade of medical alcohol on each sample block. A few drops is enough. Note the result to each surface, if any, after five minutes. Student may try to buff out any marks which may appear. Rate each finishing material on a one, two, three, etc. basis.
3. Water Test - Student places a few drops of water on each sample block. The water test is best when left on over an extended period of time. Minimum amount of time should be thirty to forty-five minutes. Note results to various surfaces and rate each finishing material on a one, two, three, etc. basis.
4. Burn Test - Student places a hot soldering iron on surface for ten seconds. Reheat soldering iron slightly and repeat at another spot close to the first burn. Note the two locations. Repeat the operation, after reheating soldering iron, in two additional spots for twenty seconds each. Repeat the operation in two additional spots for thirty seconds. Note resistance to burns and rate each finishing material on a one, two, three, etc. basis.
5. Impact Test - Student drops a one-half pound weight, with rounded corners, from ten to twelve inches in height several times, or until damage occurs. Note damage to finish and rate each finishing material on a one, two, three, etc. basis.
6. Grease and Oil Test - Student places a small amount of grease and oil on two separate locations on each block of wood being tested. Allow to stand for thirty minutes. Wipe off and evaluate any defect that is noticed. Rate each finishing material on a one, two, three, etc. basis.
7. Abrasive Test - (See Abrasive Tester) Student places rubbing compound on Abrasive Tester and operates accross finish samples. Note results (visually). Place scouring powder on tester, repeat test, and note results (visually). Place fine grade of sand or dirt on tester, repeat test, and note results (visually). Rate each finishing material on a one, two, three etc. basis.

The entire testing program can be run by a number of students at

the same time since the same test is being conducted on various finishes.

Additional testing can be done by students. Following the previous testing program, repairability of damaged surfaces can be attempted. Sand down damaged portions of test samples and feather in or match existing finishes with the same product.

Items to look for in damaged surfaces are:

1. White spots
2. Discoloration
3. Raised grain
4. Blistering
5. Scratches in surface
6. Loss of finish material in area of test
7. Sticky finish
8. Bleached-out surface
9. Stain
10. Dents
11. Other visible imperfections

#### CONCLUSIONS

Each type finish will have shortcomings. It is up to the student to determine which ones he can accept, and those he cannot. The easy way to apply finishes often offer little protection and need to have constant re-application. Hard surfaces often fail impact type tests. Some finishes are hard to apply. Expense of the finish may also be a factor which has to be considered. Appearance has to be high on the list in determining final selection. The test undertaken will help the student make an intelligent selection of his needs.

Normal safety precautions and common sense should be followed during the tests. Hot objects burn and should be handled with the respect called for. Rubbing the eyes after handling alcohol will cause irritation, and should be avoided. Preparation of the testing blocks should be conducted in well ventilated areas according to manufacturers recommendations.

No special tools, which are not generally found in the shop, are necessary. If you do not wish to construct the abrasive tester, a chalk board eraser briskly rubbed across the test samples may be substituted. A data rating form is suggested, and may be employed in the tests.



## TEST RATING FORM

## TESTS CONDUCTED

RATING	IMPACT	ALCOHOL	WATER	BURN	HEAT	GREASE & OIL	ABRASIVE
1.							
2.							
3.							
4.							
5.							
6.							
7.							

INDICATE TYPE OF FINISH IN BLANK SPACES

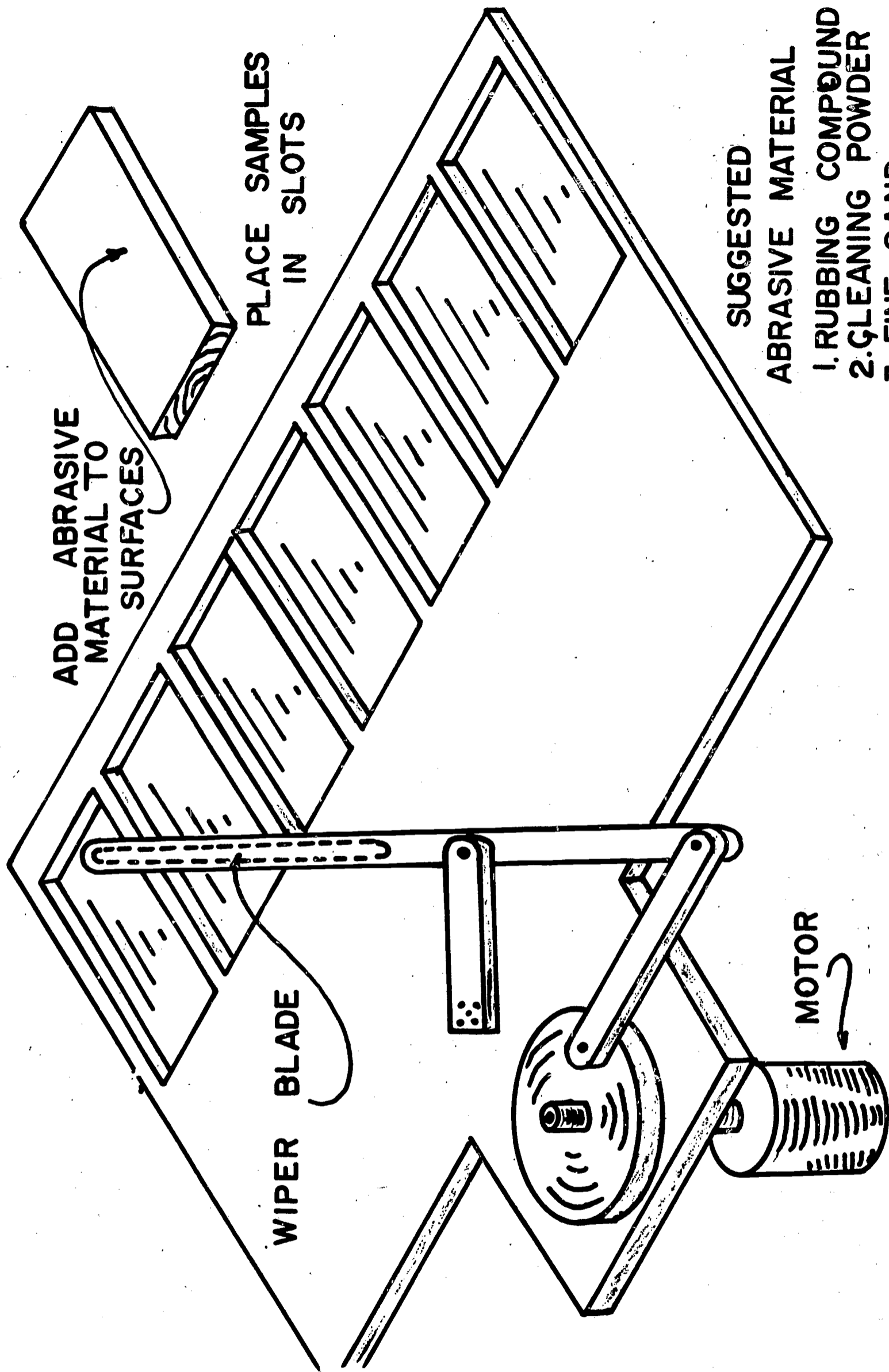

ADD ABRASIVE MATERIAL TO SURFACES

PLACE SAMPLES IN SLOTS

WIPER BLADE

MOTOR

- SUGGESTED ABRASIVE MATERIAL
1. RUBBING COMPOUND
  2. CLEANING POWDER
  3. FINE SAND

# ABRASIVE TESTER

## HOLDING POWER OF WOOD ADHESIVES

Wood adhesives of many kinds are available for use today. Many of the adhesives are designed to be used for industrial purposes, and others are made for home use. The term "glue" which has always been used to describe the joining of two pieces of materials together, does not adequately fit the wide range of adhesives being manufactured today. According to Webster's dictionary, glue is any of various viscous substances. This implies that even oil could be used as glue. Webster's definition of any adhesive is, "sticky; tenacious; of the nature of adhesion; apt or tending to adhere; clinging". This implies that the term "adhesives" should be used.

Adhesives fall into two basic categories, hot and cold. Hot adhesives have been used to a great extent in the cabinetmaking industry and are made from animal hides and fish. Today, with the development of many new cold-setting adhesives, hot adhesives are seldom used. Many of the cold-setting adhesives are still made from the bones, skins, and sinews of animals; and the bladder, skin and offal of fish. The newer cold-setting adhesives are made from the starch of such plants as corn, arrowroot, cassava and potatoes; the casein of milk; and plastic resins. All of the adhesives, though they tend to be water resistant, are not waterproof. Waterproof adhesives are made from casein or from blood albumin.

### STATEMENT OF THE PROBLEM

Most of the adhesives on the market today come already prepared in liquid form. The prepared liquid adhesives are easily applied, especially if they are in a plastic squeeze container or tube. Others, like the waterproof adhesives, which come in powder form and need mixing, must be properly prepared; and usually a period of curing is required before application can be made. One other important feature in the selection of an adhesive is the time required for setting before the material can be worked on. Some of the new resins set up in fifteen minutes and are ready to work, while other adhesives require a twenty-four hour waiting period.

The principle of adhering two boards together is the same no matter what type of adhesive is being used. The surfaces must be thoroughly cleaned and be absolutely true. When the two surfaces touch each other entirely, the best joint will be achieved. This wood-to-wood contact will allow the adhesive to penetrate the pores to make a strong bond that will lock the two pieces together. A wide, open joint with excess adhesive makes a weak joint that in time will break apart. During the clamping process, excess adhesive may squeeze out of the joint, run

down the board and stain the surface. In many instances, it is necessary to take this fact into consideration and select an adhesive that will not leave a stain.

The most satisfactory results when adhering two pieces of wood depends upon: the cleanliness of the wood, the accuracy of the joint, the application of the adhesive, the clamping technique and the drying time. Assuming these factors can be made constant under controlled conditions, it should be possible to test adhesives to compare their holding power.

#### SUGGESTED EQUIPMENT AND PROCEDURE

**Materials:** Samples of each type of adhesive to be tested. Enough samples of 1" x 2" x 6" clear white pine to permit a minimum of three tests for each type of adhesive.

**Tools and Equipment:** Construct the Wood Splitting Apparatus similar to the one shown in Fig. 1. A mallet and a 2" chisel for splitting the wood joints. An oven for conducting the heat tests. A pail for conducting the soaking tests.

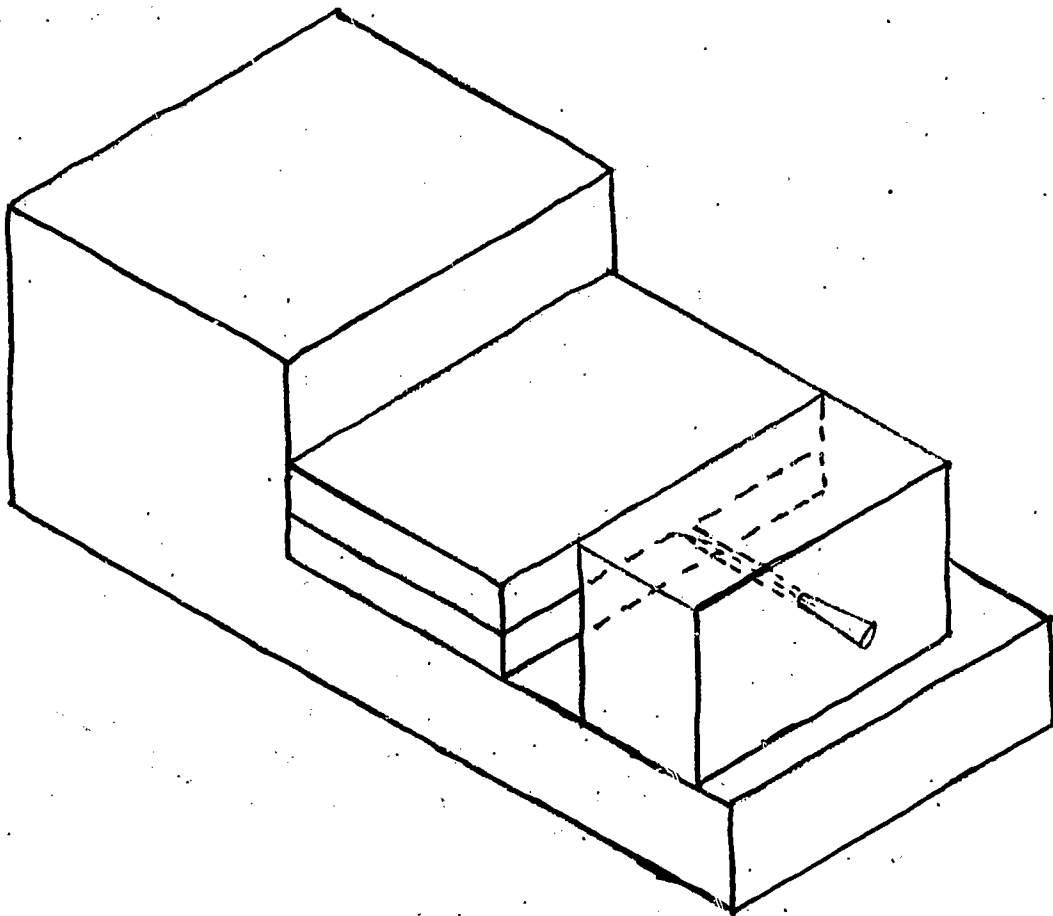

Fig. 1 Wood Splitting Apparatus

Procedure: Label each matching pair of blocks being tested with the name of the adhesive. Also, number each of these matching pairs of blocks. If each pair of blocks is marked with the name of the adhesive and matching numbers, identification should be relatively easy. This will eliminate mismatching samples during the adhering process and will prevent erroneous reading and recording of the findings.

In the application of each adhesive, pay particular attention to the spreading quality. Make entry on the 'Holding Power of Wood Adhesives' table according to the classifications established in the "findings".

In the application of the adhesive allow a little of the excess to remain on the wood. Pay particular attention to the stain characteristics and make an entry on the table according to the classifications established.

The following are tests for determining the holding power of wood adhesives:

1. Thirty Minute Test - Spread an even coat of adhesive on the face of each block of wood to be treated and clamp the pieces of wood together. Test for adhesive quality by trying to pull the blocks apart after a period of thirty minutes. Observe the tackiness of the adhesive and how well it adheres to the wood. Run a minimum of three strength tests with each adhesive and record the average findings.
2. Twenty-Four Hour Test - Spread an even coat of adhesive on the face of each block of wood to be tested. Clamp the pieces together and allow to dry for twenty-four hours. Place each sample in the 'Wood Splitting Apparatus' and with the cutting edge of the chisel lined up against the joints, strike a firm blow on the chisel handle with the mallet. Run a minimum of three strength tests with each adhesive and record the average findings.
3. Heat Test - Spread an even coat of adhesive on the face of each block to be tested. Clamp the pieces together, and allow to dry for twenty-four hours. Place the test blocks in an oven, preheated to 150° F., for a period of thirty minutes. Place each sample in the 'Wood Splitting Apparatus' and with the cutting edge of the chisel lined up against the joint, strike a firm blow on the chisel handle with the mallet. Run a minimum of three strength with each adhesive and record the average findings.
4. Soaking Test - Spread an even coat of adhesive on the face of each block of wood to be tested. Clamp the pieces together, and allow to dry for twenty-four hours. Completely submerge

**Good:** More than 75% of the area was strong enough to pull wood fibers from the adhered surfaces.

**Satisfactory:** More than 50% of the area was strong enough to pull wood fibers from the adhered surfaces.

**Poor:** Less than 10% of the area was strong enough to pull wood fibers from the adhered surfaces.

**Very Poor:** The joint separated completely with one or two blows of the mallet on the chisel.

**Precautions:** To insure uniformity, cut all of the wood samples from the same board. The wood surfaces to be tested must be perfectly jointed. Do not sand the surfaces, as it will tend to make them uneven and may leave particles of grit and dust that will affect the strength of the joint. After the surfaces have been jointed, protect them carefully until they are needed for use.

Use only fresh adhesives for the testing, and mix according to the manufacturer's directions. Apply the adhesives smoothly and evenly to all of the surfaces to be joined. Use proper clamping techniques and apply uniform pressure to the joints. Avoid any glue-starved joints caused by excessive clamp pressure.

Accuracy of time in all operations is an important factor. Work only on the number of test samples that can be adequately controlled at one time. Apply the adhesives and clamps within reasonable time. Time the drying, heating, and soaking tests as closely as possible.

ADHESIVE	SPREAD	STAIN	STRENGTH TEST				RATING
			30	24	SOAK	HEAT	

the test blocks in water for a period of twenty-four hours. Place each sample in the 'Wood Splitting Apparatus', and with the cutting edge of a chisel lined up against the joint, strike a firm blow on the chisel handle with the mallet. Run a minimum of three strength tests with each adhesive, and record the average findings.

Findings: Conduct the experiment and record the findings in the Holding Power of Wood Adhesives table.

The following classifications have been devised to determine the spread quality, resistance to stain, pull and strength characteristics of wood adhesives.

#### Spread Quality

Excellent: Flows evenly and smoothly over the entire surface with no effort.

Good: Spreads over the entire surface with some effort.

Poor: Spreads over the entire surface with a great deal of effort.

#### Staining Effect

Excellent: No evidence of stain.

Good: Slight evidence of stain.

Poor: Widespread evidence of stain.

#### Pull

Excellent: Blocks could not be pulled apart.

Good: Blocks were difficult to pull apart.

Poor: Blocks pulled apart very easily.

#### Strength

Excellent: Impossible to separate at the joint.

Very Good: More than 90% of the area was strong enough to pull wood fibers from the adhered surfaces.

## VALIDATING THE COMMON SCREW HOLE CHART

Research, testing and experimentation play an important role in the development of our highly technical society. Development of student participation in the examination of materials and processes will increase young peoples capacity to function at a higher degree of efficiency and lead a useful and productive life. ( 4:92 )

A review of published literature reveals that a number of people have developed materials testing equipment in Industrial Arts classes in an attempt to introduce students to a better understanding of industrial materials and processes. (16:32-34, 15:35-37)

To accomplish this objective or goal, an Industrial Arts program should help students acquire skills and attitudes that are essential in present day industry with its complicated materials and processes. A good program should engineer attitudes willing to accept the inevitable changes in the world of work, changes in vocation and even the social order in which we live. The Industrial Arts areas covered, and the variety of experiences presented indicate that strides are being made in the areas of research and experimentation. (1:92-94 )

It is hoped that with the use of the following material, we are able to instill in our students just a few of the unique skills and attitudes involved in industry today and tomorrow.

### STATEMENT OF THE PROBLEM

In most woodworking textbooks, a section usually deals with wood screws as fasteners. In general, a short statement deals with the physical composition and characteristics of wood screws. A wood screw chart is shown, briefly describing the application of pilot holes in using wood screws.

It is the purpose of this study to validate the common screw hole chart use by the woodworking trade and to determine if the information given in regard to the selection of pilot hole drills is correct.

### MECHANICAL PROPERTIES OF WOOD

The structure of wood makes it unlike any other building material, as no two pieces have the same strength properties. As a result of this factor, tests have been developed and performed on many species to obtain some kind of an average value under performance. (3:597-601)

The results of such tests rely on several properties of wood that



must be taken into consideration. Some of these properties include:

1. Density - Mass or weight of any substance per unit of volume, such as 10 grams per cubic centimeter or 30 pounds per cubic foot.
2. Specific Gravity - Ratio of density of a material to the density of a standard substance taken at a standard temperature. (Usually water). (10:488 )
3. Moisture Content - Amount of water contained in wood, usually expressed as a percentage of the weight of the oven dry weight.
4. Oven-Dry Weight - Wood dried to a constant weight in an oven, above 101°-105° C or 214°-221° F.

Specifications for some wood assemblies require specific gravity data to evaluate the strength necessary for the assembly as a whole. Adherence to a standard method is time consuming and laborious, so a method of determining this data has been devised known as the Rapid Flotation. (10:465-66)

In this method an oven dry block, 1" x 1" x 10", is marked lengthwise at one inch intervals. The block is floated in a test tube partially filled with water. The water line at which this block floats serves as a direct measure of specific gravity. For example, if the water line on the sample is 5  $\frac{1}{4}$ " from its base, the specific gravity of the piece is .575.

#### SPECIFIC GRAVITY OF COMMON WOODS

(Based on Oven Dry Weight)

Alder	.43	Douglas Fir	.51	Pine, Ponderosa	.42
White Ash	.64	American Elm	.55	Poplar	.43
Basswood	.40	Gum, Red	.53	Redwood	.39
Yellow Birch	.66	Hickory	.72	Spruce	.39
Butternut	.40	Maple, Hard	.68	Walnut	.56
Cherry	.53	Oak	.61	Willow	.41

(6:71-73)

#### SUGGESTED STUDENT PROCEDURE

Preparation of test sample:

1. Obtain four samples of hardwood and four samples of soft wood. Each specimen is to be squared to 3/4" x 2 1/2" x 8".

2. Lay out test samples in accordance with drawing of test piece.
3. Lightly center punch each hole location.
4. Drill holes on drill press - DO NOT DRILL HOLES BY HAND. Carefully drill the correct size hole in each location. Drill all holes to a depth of 5/8". Drill an additional hole in the designated location.

Test Procedures:

1. Drive screw with screwdriver to a depth of 5/8". USE GAUGE TO CHECK DEPTH.
2. Insert test piece in test machine, check alignment of screw, pulling tool and test piece.
3. Apply pressure slowly and at a constant rate, watching gauge closely.
4. Record maximum pressure to move screw.
5. Carefully drive another screw in the next hole on test sample.
6. Pull as before, recording maximum pressure.
7. Repeat process on all softwood samples.
8. Repeat process on all hardwood samples.
9. In the extra 1/8" and 3/32" diameter holes, drive a screw with a hammer. Pull as before and record results. Drive to 5/8" depth.
10. Other deviations of test might be to:
  - a. Use same screw for entire test.
  - b. Use a lubricant such as beeswax or soap as a lubricant before driving screw.
  - c. Drill pilot holes with a screwmate and with a twist drill. Make comparisons of holding power of screw.
  - d. Pull screws immediately after driving.
  - e. Drive screws and let sample set for a period of a week.

## LAYOUT OF SAMPLE

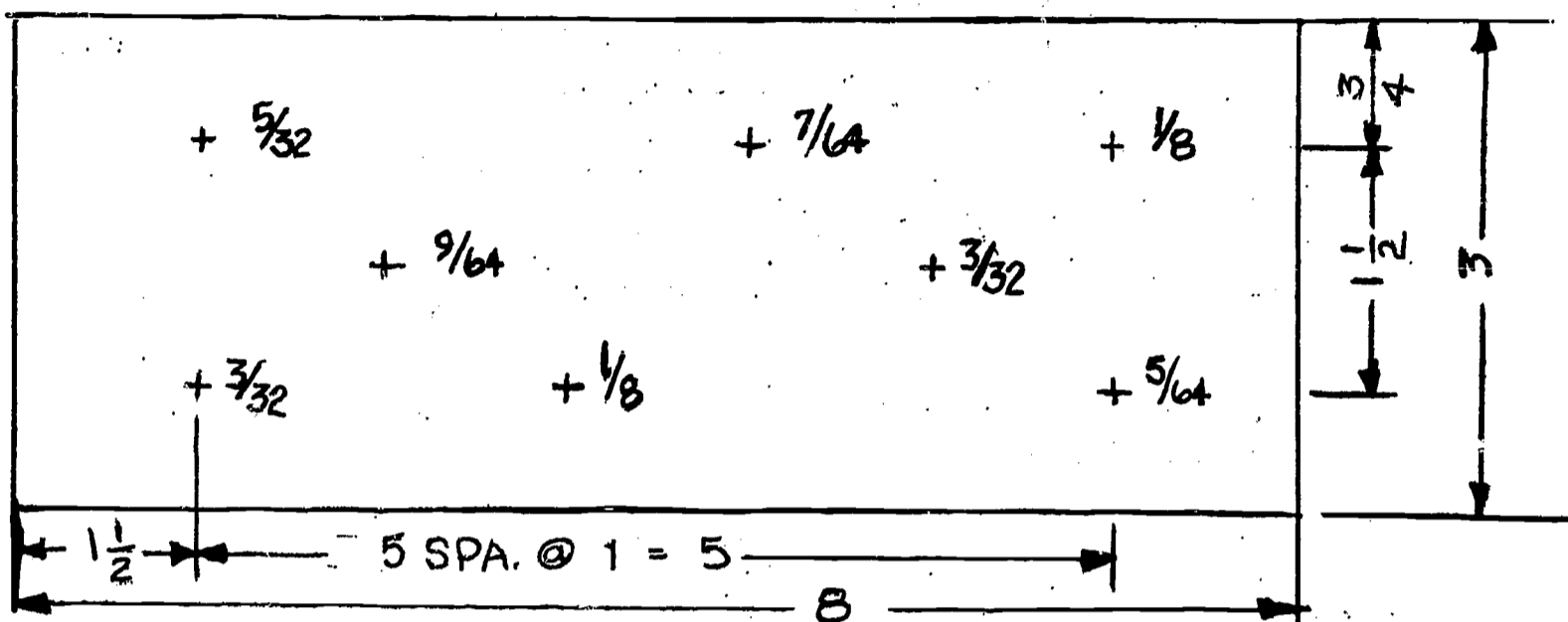

### Precautions to Observe During Test:

1. Samples of each species from same piece of wood. All samples must be the same thickness.
2. Drill all pilot holes at right angles to tangential surface, and as accurately to size and depth as possible.
3. Select a screwdriver that fits the screw head slot.
4. Drive screw straight. Screws driven at an angle will tend to make the test invalid.
5. Avoid any sudden movement of the jack handle that will cause erratic motion.
6. Carefully read and record sample weight before each test.
7. Determine moisture content of each sample.
8. Determine specific gravity of specie, either by (a) flotation method or (b) reading from a prepared chart.

### Special Tools and Equipment:

1. Balance scales
2. Shop constructed test apparatus
3. Oven capable of reaching a temperature of  $250^{\circ} \text{ F.}$
4. Test tube and holding device.

**"TYPICAL SCREW HOLE CHART"**

**American (National) Standard  
Screw Gauge**

<u>Gage No.</u> <u>Wire Size</u>	<u>Gage No.</u> <u>Dec. Equiv.</u>	<u>Body</u> <u>Size Drill</u>	<u>Pilot or Anchor Hole</u> <u>Hardwood</u>	<u>Softwood</u>
0	.060	1/16	---	---
1	.073	5/64	1/16	---
2	.086	3/32	1/16	3/64
3	.099	7/64	1/16	3/64
4	.112	1/8	3/32	5/64
5	.125	1/8	3/32	5/64
6	.138	9/64	3/32	5/64
7	.151	5/32	1/8	3/32
8	.164	11/64	1/8	3/32
9	.177	3/16	1/8	9/64
10	.190	3/16	5/32	9/64
12	.216	7/32	3/16	9/64
14	.242	1/4	3/16	11/64
16	.268	9/32	15/64	13/64
18	.294	5/16	17/64	15/64
20	.320	11/32	19/64	17/64
24	.372	3/8	21/64	19/64

(8:424)

## QUESTION AND ANSWER SHEET

1. Was a screw broken at anytime? \_\_\_\_\_
2. If screw is broken, was it broken while driving or pulling?  
\_\_\_\_\_
3. If screw is broken, was it in hardwood or softwood?  
\_\_\_\_\_
4. If the screw is broken, what size was the hole? \_\_\_\_\_

Note: If a screw breaks while driving, obtain another, drill pilot hole of the same size and lubricate screw with paraffin, soap or graphite and try driving in the new pilot hole. (Make note on data sheet when using lubricant).

5. Was success obtained in driving lubricated screw? \_\_\_\_\_
6. Did it require more, as much or less force to pull the lubricated screw? \_\_\_\_\_
7. What are your conclusions in the use of a pilot hole to drill in hardwood and softwood?  
Make comparison from Screw Chart.
  - a. Hardwood -
  - b. Softwood -

## Additional Investigation:

1. Drill two additional  $1/8$ " holes in the hardwood samples. (See drawing of sample).
2. Hammer a No. 8  $1 \frac{1}{2}$ " screw in the pilot hole to a  $5/8$ " depth.

3. Pull as before and record information in the extra column.
4. What is the comparison of the results for a hammered screw and a conventionally driven screw? \_\_\_\_\_

---

---

# DATA SHEET

Softwood Specie	M.C.	Wt. Grams	S.G.	Force required to remove a No. 8 1½ FH wood screw from anchor holes in tangential surface								Remarks	
				5/32	9/64	1/8	7/64	3/32	5/64	3/32	3/32		
1.													
2.													
Average of two samples													
Softwood Specie	M.C.	Wt. Grams	S.G.	Force required to remove a No. 8 1½ FH wood screw from anchor holes in tangential surface								Remarks	
				5/32	9/64	1/8	7/64	3/32	5/64	3/32	3/32		
1.													
2.													
Average of two samples													
Hardwood Specie	M.C.	Wt. Grams	S.G.	Force required to remove a No. 8 1½ FH wood screw from anchor holes in tangential surface								Remarks	
				5/32	9/64	1/8	7/64	3/32	5/64	1/8	1/8		
1.													
2.													
Average of two samples													
Hardwood Specie	M.C.	Wt. Grams	S.G.	Force required to remove a No. 8 1½ FH wood screw from anchor holes in tangential surface								Remarks	
				5/32	9/64	1/8	7/64	3/32	5/64	1/8	1/8		
1.													
2.													
Average of two samples													

# SET UP FOR SCREW PULLING

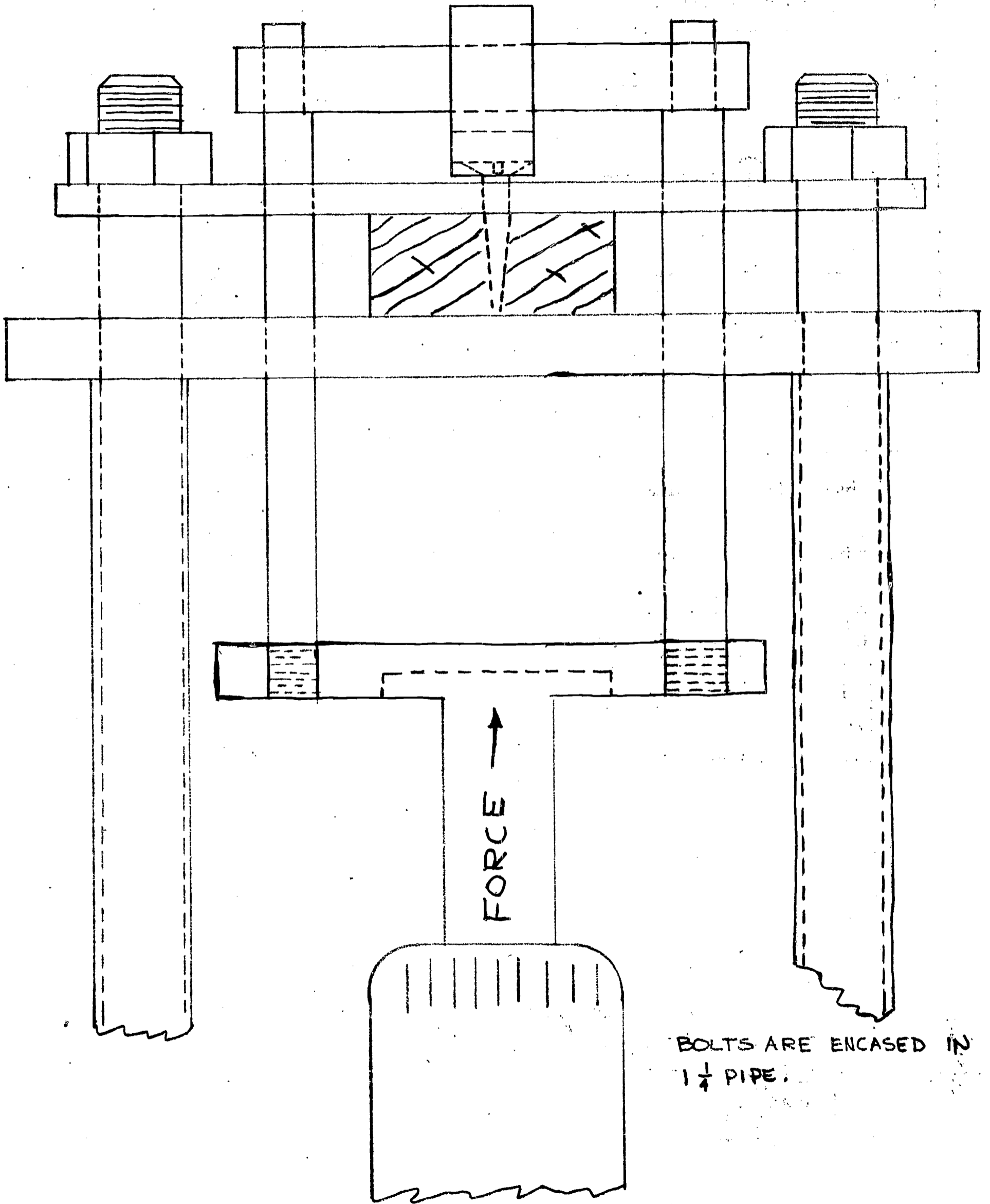

BOLTS ARE ENCASED IN  
1 1/4 PIPE.



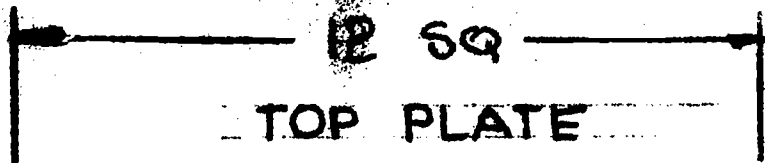

$\frac{3}{4}$  DIA 4 HOLES

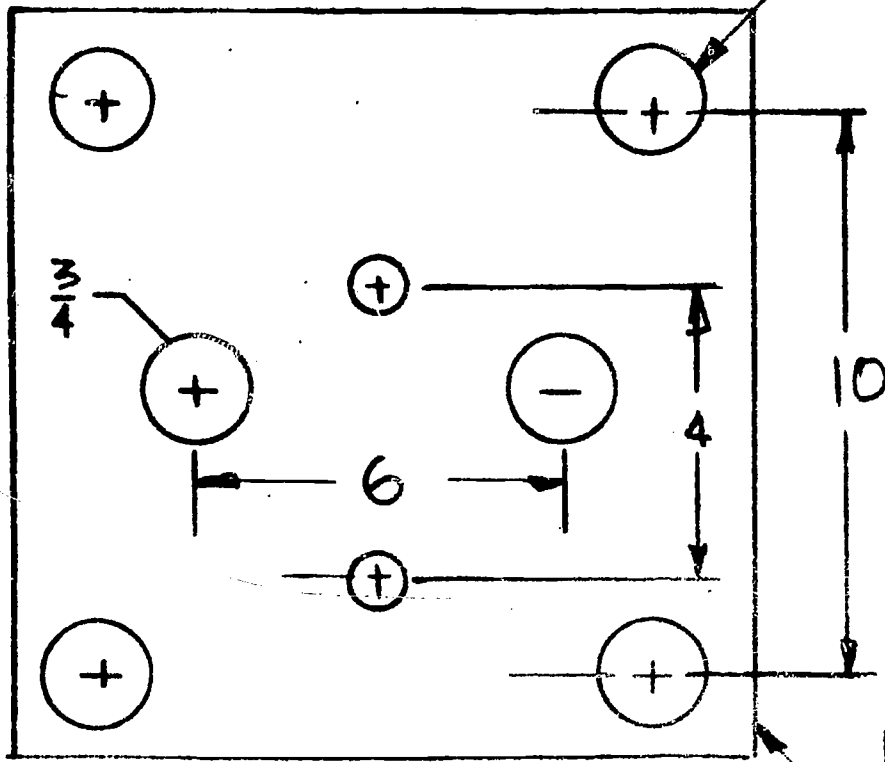

SCREW PULLER

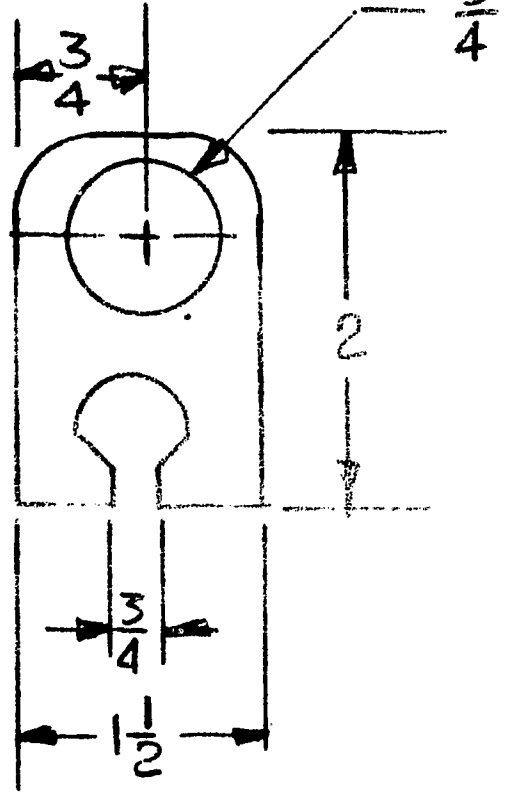

$\frac{1}{2}$  PLATE

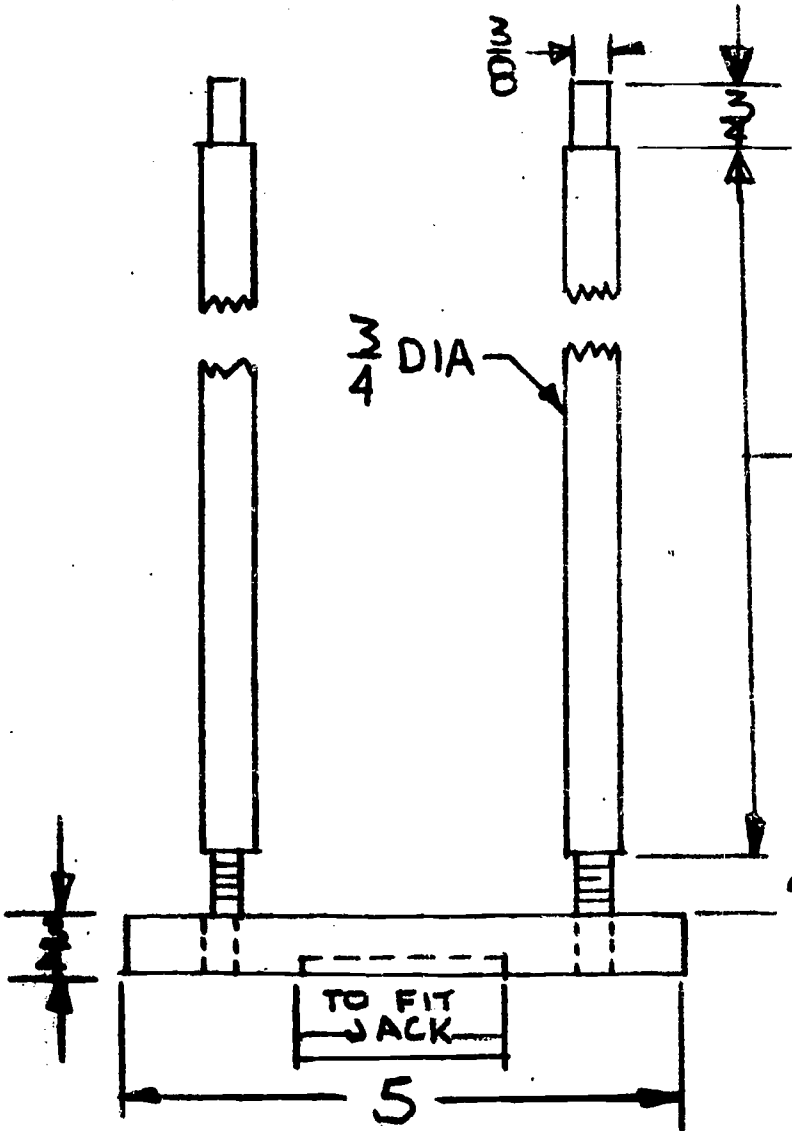
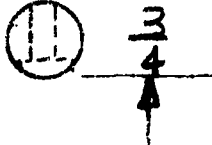
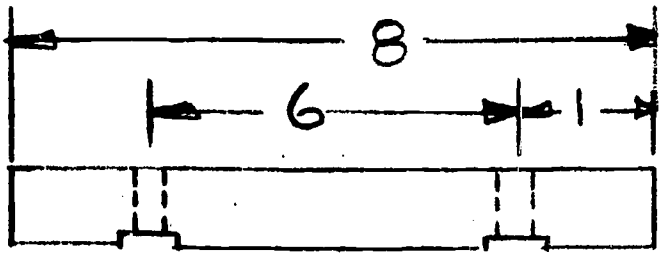

MAKE TWO SETS  $4\frac{1}{2}$  & 9

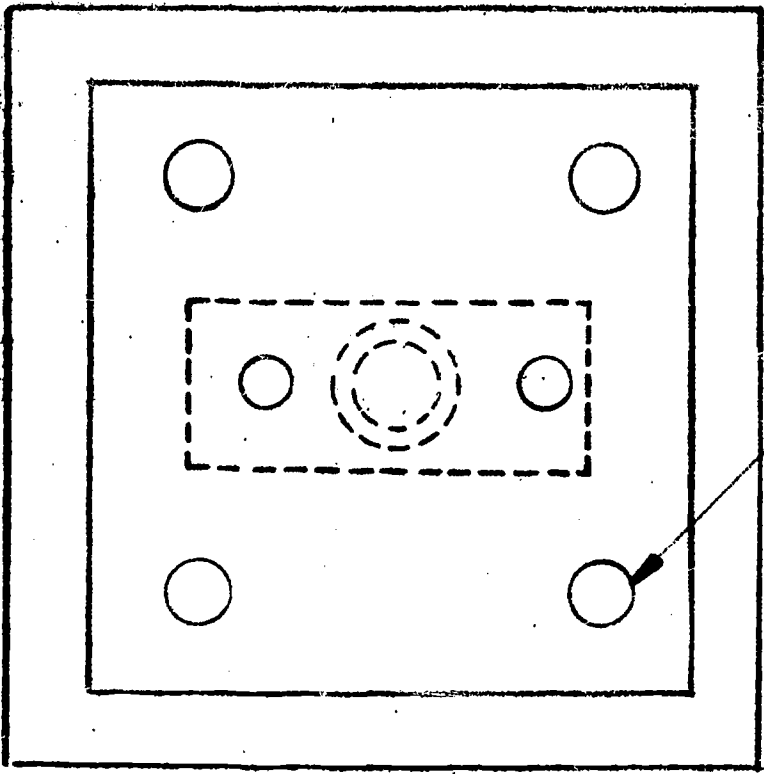

4  $\frac{3}{4}$  DIA HOLES

4 PC  $\frac{3}{4}$  CRS REDI-BOLT

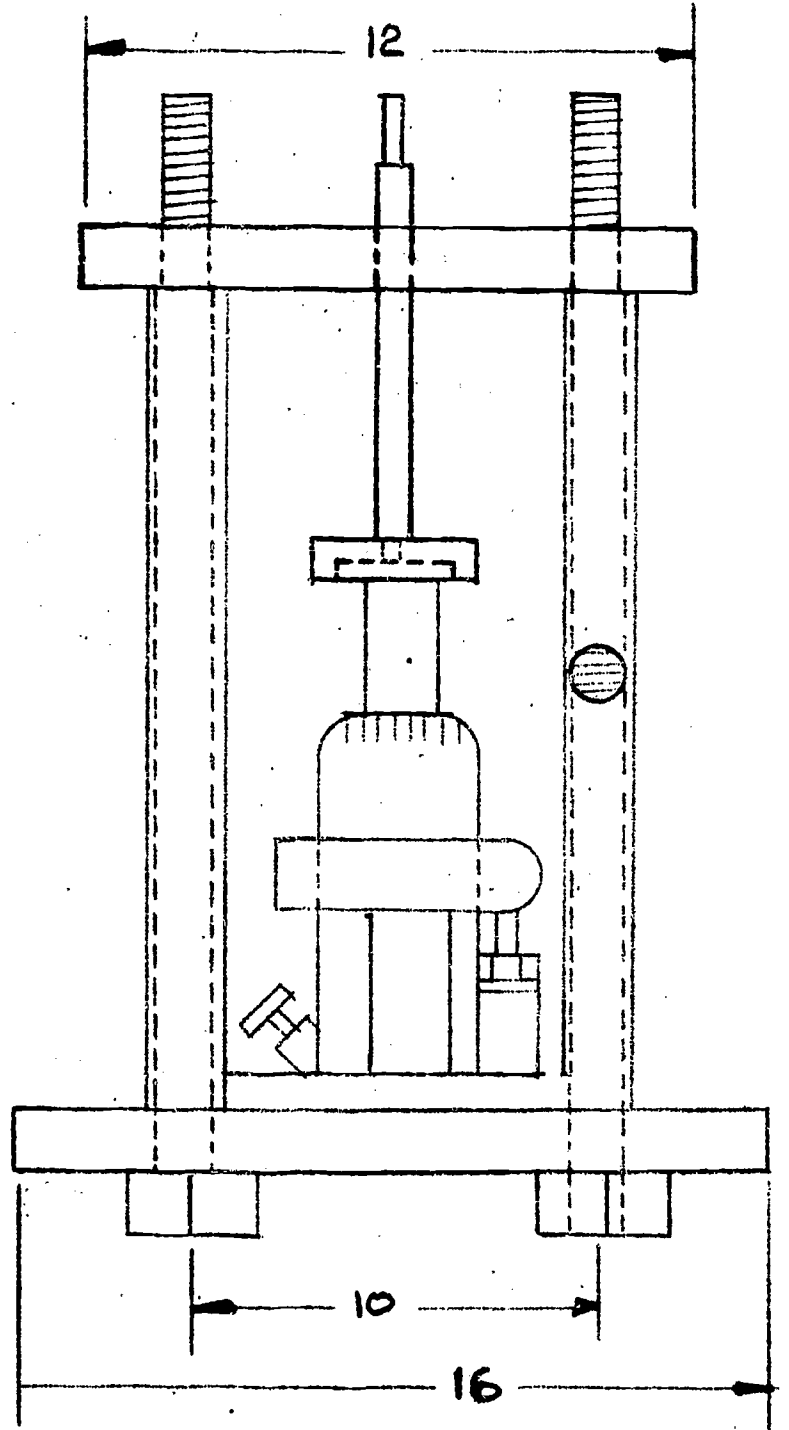
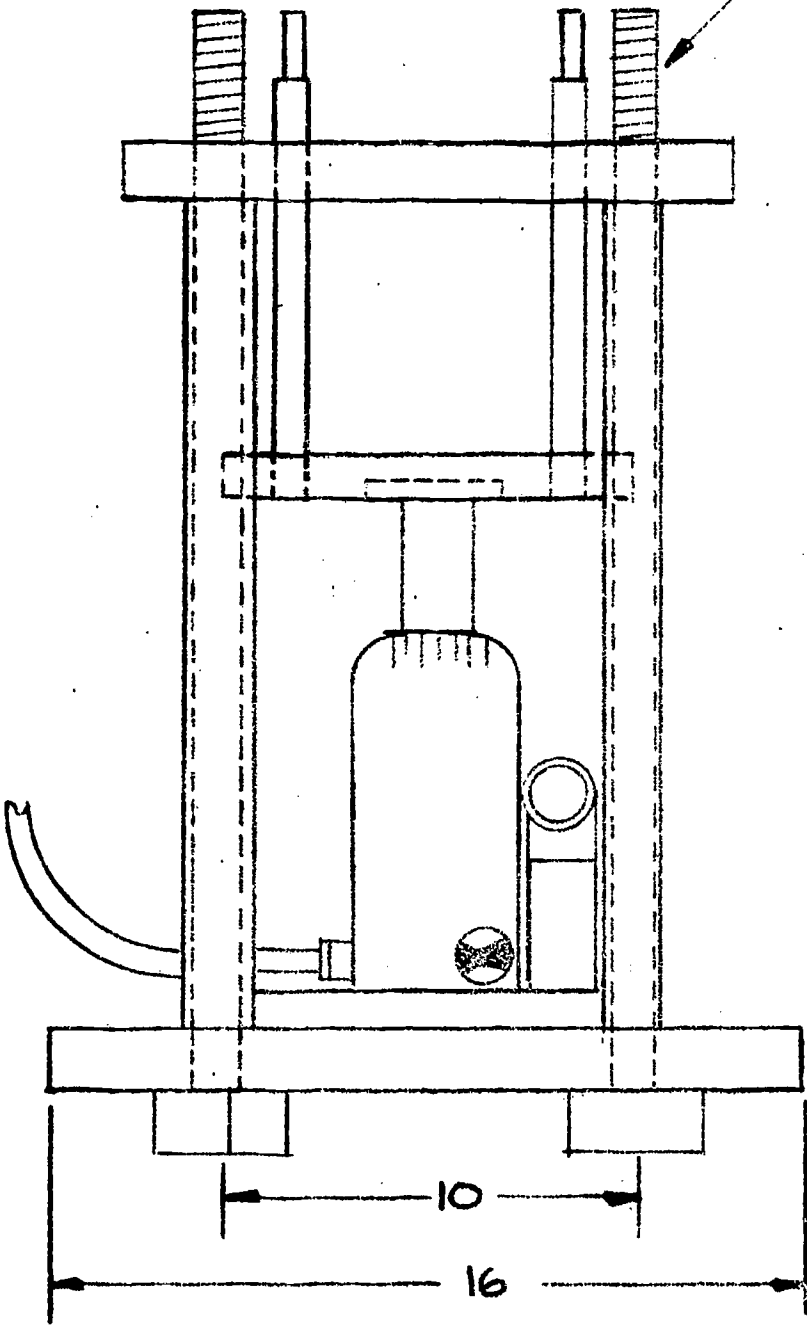

## BIBLIOGRAPHY

## A. BOOKS

1. American Council on Industrial Arts Teacher Education, 16th Yearbook. "Implications for Student Growth," Evaluation Guidelines for Contemporary Industrial Arts Programs, Bloomington, Illinois; McKnight & McKnight Publishing Company, 1967.
2. American Society for Testing and Materials. "Structural Sandwich Construction; Wood; Adhesives," Book of ASTM Standards Part 16, Baltimore: American Society for Testing and Materials, 1966.
3. Brown, Panshin and Forsaith, Handbook of Wood Technology, Volume 2. New York: McGraw-Hill Book Company, 1952. Pp. 597-601.
4. Earl, Arthur W., Experiments With Materials and Products of Industry. Bloomington, Illinois: McKnight & McKnight Publishing Company, 1960.
5. Feirer, John Louis, Cabinetmaking and Millwork. C. Bennett Company, 1967.
6. Hansen, Howard J., Modern Timber Design. London: John Wiley & Sons, 1948, Pp. 71-73.
7. Jeffery, Harry R., Wood Finishing. Chas. A. Bennett Company, 1957.
8. Ludwig and Ludwig, Metalwork Technology and Practice. Bloomington, Illinois: McKnight & McKnight Publishing Company, 1962, P. 424.
9. Minns, E. W., Art of Restoring & Refinishing Antique Furniture. Moore Printing Co., Inc., 1939.
10. U. S. Department of Agriculture, Wood Handbook. Agricultural Handbook No. 72, Forest Service. Washington: Government Printing Office, 1955.
11. Scharff, Robert, Complete Book of Wood Finishing. McGraw-Hill Co., 1956.
12. Soderberg, George, Spot Finishing - Restoring & Maintaining Finishes. Bruce, 1958.

13. Wampler, Rollin H., Modern Organic Finishes. Chem. Publishing Company, 1946.
14. Vanderwalker, Fred Norman, Wood Finishing, Plain & Decorative. Drake, 1957.

#### B. PERIODICALS

15. Rockwell, James. "Bending Strength of Wood Beams", Industrial Arts and Vocational Education, October, 1966, pp. 35-37.
16. Smith, Warren G., and Rapp, Al. "Equipping for Materials Testing", Industrial Arts and Vocational Education, October, 1966, pp. 32-34.

END

11 • 21 • 69