

By-Dionne, Edward A.; Parkman, Ralph

Cybernation and Man--A Course Development Project, Report Number 2, Final Report.

San Jose State Coll., Calif. School of Engineering.

Spons Agency-Office of Education (DHEW), Washington, D.C. Bureau of Research.

Bureau No-BR-7-I-020

Pub Date 28 Feb 68

Grant-OEG-9-8-7-0028-010

Note-128p.; Supplement to "Cybernation and Man--A Course Development Project;" Number 1, 28 Feb 67.

Available from-Dr. Ralph Parkman, Chairman, Dept. of Materials Science, San Jose State College, San Jose, Calif. 95114

EDRS Price MF-\$0.75 HC-\$6.50

Descriptors-Agricultural Machinery, *Agriculture, Agronomy, Art, Art Activities, *Artists, Automation, Computer Assisted Instruction, Computer Oriented Programs, Computer Programs, *Computers, *Cybernetics, Demography, Digital Computers, Electromechanical Technology, Farm Management, Programing, Programing Languages, Systems Analysis, *Transportation

Identifiers-FORTRAN

Transportation, Agriculture, and Art are used as examples to establish how technology, especially computer-based technology, is involved in the life of man. Cities grow in population very rapidly; motor vehicles grow in number even more rapidly; both circumstances raise problems--traffic congestion, economic loss, air pollution, urban planning--which necessitate information gathering, prediction, evaluation, and decision making. The computer comes into its own, not only in these areas, but also in some of the research planning. A good example is the San Jose traffic control system. Technology has brought prodigious productive efficiency to agriculture, where the problems are even more complex, more urgent, and the options numerous. The computer plays a big role here, too. In Art, technology has always played a part--in the manufacture of materials. Nowadays that part has been expanded, and even the computer is sometimes used in the process of creation in the visual arts and in music; although in literature the computer's role is as yet vestigial. An introduction to computers and computer programing using the FORTRAN language is also given in this guide as part of a course in cybernetics. A bibliography brings to an end this concluding half of a two-part report. (Part I is EM006096). (GO)

ED031089

FINAL REPORT

PROJECT NO. 7-I-020

GRANT NO. OEG-9-8-7-0028-(010)

CYBERNATION AND MAN

A COURSE DEVELOPMENT PROJECT

NO. 2

February 1968

U. S. DEPARTMENT OF
HEALTH, EDUCATION AND WELFARE
OFFICE OF EDUCATION
BUREAU OF RESEARCH

U.S. DEPARTMENT OF HEALTH, EDUCATION & WELFARE
OFFICE OF EDUCATION

THIS DOCUMENT HAS BEEN REPRODUCED EXACTLY AS RECEIVED FROM THE
PERSON OR ORGANIZATION ORIGINATING IT. POINTS OF VIEW OR OPINIONS
STATED DO NOT NECESSARILY REPRESENT OFFICIAL OFFICE OF EDUCATION
POSITION OR POLICY.

CYBERNATION AND MAN

A COURSE DEVELOPMENT PROJECT

REPORT NO. 2

Project No. 7-I-020

Grant No. OEG-9-8-70020-0028

Edward A. Dionne

Ralph Parkman

February 28, 1968

The research reported herein was performed pursuant to a grant with the Office of Education, U. S. Department of Health, Education and Welfare. Contractors undertaking such projects under government sponsorship are encouraged to express freely their professional judgment in the conduct of the project. Points of view or opinions stated do not, therefore, necessarily represent official Office of Education position or policy.

SCHOOL OF ENGINEERING

SAN JOSE STATE COLLEGE

SAN JOSE, CALIFORNIA 95114

EM007237

TABLE OF CONTENTS

Acknowledgments	iii
Introduction	1
Part I	
A. Cybernation and Transportation	3
B. Cybernation and Agriculture	18
C. Cybernation and the Artist	26
D. References - Part I	34
Part II	
A. Introducing Computers	38
B. Computers - "Doing Machines".....	41
C. Functional Units of a Computer	44
D. Programming Computers	57
E. Examples of Computer Uses	87
F. References - Part II	93
Summary	95
Bibliography	96
Appendix	A-1

ACKNOWLEDGMENTS

The authors are indebted to many others, both colleagues and students, who have enthusiastically participated in the development of Cybernation and Man, and have helped make it a continuously absorbing educational experience.

S. P. R. Charter has again served as consultant and teacher, and has made invaluable contributions. Special thanks are due to Professors Jorge Barriga, David Hatch, Wayne Champion and Fred Spratt for many provocative discussions. Also the help of Mr. Gene Mahoney in providing material from an unpublished traffic study is gratefully acknowledged.

The assistance of Henry Cock and Emmy Lou Miller in preparing material for this report is appreciated.

San Jose State College
San Jose, California
February, 1968

Edward A. Dionne, Professor
Engineering Graphics and
Services

Ralph Parkman, Professor
Materials Science

INTRODUCTION

This report is supplementary to an earlier one, entitled *Cybernation and Man - A Course Development Project*, which was submitted to the Division of Higher Education Research of the U. S. Office of Education on February 28, 1967.

The first report had described details of the interdisciplinary course, *Cybernation and Man*, to provide a guide to other institutions interested in developing a program with similar objectives. The primary objective has been to establish a base for communication between the many academic disciplines, whether rooted in the humanities and arts, in social or physical science or in technology.

In the six semesters that the course has been offered, this aim has been approached by examining the ways in which the lives of the students can be affected by technology - especially computer-based technology. The examination has proceeded along several fronts. Class activities have included lecture-seminar sessions led by local faculty and guests with special qualifications in specific subject areas; discussions of student papers; field trips; viewing of relevant films; and, for students who have had no previous experience, an introduction to the use of the computer had been provided.

Descriptive materials relating to each of these activities except the last were contained in the earlier report, single copies of which may still be obtained by writing to:

Dr. Ralph Parkman, Chairman
Dept. of Materials Science
San Jose State College
San Jose, California 95114

Since the completion and dissemination of that report, there has been a continuing interest in our program as evidenced by letters from many colleagues.

At the beginning of the Spring semester, 1967, when the report was finished, there were a few major topics for which instructional resource materials had not been fully developed. It was decided to request additional funds from the U. S. Office of Education to provide some time for developing such materials in a form useful to others. The support was granted for a period from September 1, 1967 to February 28, 1968. This report is a result of that study.

The report is in two parts. Part I, prepared by R. Parkman, contains a treatment of ideas related to the three topics: Cybernation and Transportation, Cybernation and Agriculture, and Cybernation and the Artist. Each of these topics is discussed in a more detailed way than those which were summarized in the earlier report. The intention is to offer the reader a model upon which he may construct a unit of study. The treatment is designed to be speculative-to pose a variety of questions about the subjects, which fully recognize the complexities involved. Each topic is also accompanied by a current bibliography containing reference material in the form of books, reports, articles and films. A teacher who wishes to conduct class sessions in which these topics are examined should find this section relevant and useful.

Part II has been prepared by E. A. Dionne. It contains a typical short instructional unit on computers designed for the non-technical teacher. It is set up in three parts and includes a bibliography. First there is a short presentation of contemporary computer applications designed to start an interest in keeping abreast of the continuing growth of those new technological innovations. The teacher who is stimulated by these brief comments is on the way to becoming addicted to reading and discussing new and fascinating computer uses.

The second part is a brief typical classroom lesson on the computer as a machine. The functional units are described and classified in terms that were found acceptable by non-technical students in the Cybernation and Man class. Some teachers could use the material as a base for lectures on this topic.

The last section is devoted to computer programming. The mode used is the popular Fortran language applicable to a machine such as the IBM 1620, many of which are now in service in colleges and high schools. Here again is a set of notes that will help instruct those teachers who have little or no background in programming. The notes then could be used as the base for an instructional unit in computer problem solving by Fortran coding.

Part I

A. CYBERNATION AND TRANSPORTATION

The major topics surveyed in Cybernation and Man, with few exceptions, cross many boundaries. Some could be the bases for entire courses. Superficiality is a harsh word which is often leveled at survey courses, even those with a clear aim in mind, and one must try hard to avoid promoting it, by offering a carefully focussed examination of relevancies in the limited time available for one topic. The student whose interest is aroused can then continue his reading from the broad selection of references which are made available to him.

To illustrate how one such subject has been treated in no more than three formal class meetings, the topic of Cybernation and Transportation is here discussed as a case study in point.

Many disciplines, including geography, political science, engineering, history and economics have an interest in transportation problems. The point of view of any one of these fields may be emphasized if the primary resource person in a given semester is so oriented, but the overlapping concerns are always considered. Essentially, a successful treatment rests first upon carefully selected and readily available reference material. Second, it is desirable to have an able, well-briefed resource person who can illuminate the broad picture of transportation in an age of cybernation; or alternatively, one specific aspect which through discussion and reading can be tied in with the larger problem. Third, concrete illustrations of approaches to transportation problems through films or field trips give immediacy to the treatment. Fourth, the students need to participate actively by writing papers which are then analyzed in small discussion groups.

When the course schedule is being made out, a resource person from the college or the community is asked to speak on a given date. This person could be an official of the Bay Area Rapid Transit District, a city traffic engineer or perhaps a geographer who specializes in transportation. When inviting him, the course coordinator will describe the backgrounds of the students in the class, will explain the aims of the class in examining transportation problems, and will make available some of the references to be provided the students.

Prior to the appearance of the speaker, the students receive a one page memorandum outlining the nature of the required paper and some possible (though not exclusive) ways of approach-

ing the questions posed; several reprints of significant articles or papers (for which permission to reproduce has been obtained), and a list of library references. The due date of the paper is given as approximately three weeks after the appearance of the speaker, and the class discussion of papers follows this date by one week. This gives time for reading and grading by the course instructors who then lead the small group discussions. Other topics, of course, are examined in the three weeks of class sessions following the appearance of the speaker, before the papers are due. One of the sessions, however, ought to be given over to a field trip if there is a related activity nearby. This past semester a trip was taken to the San Jose-IBM Computerized Traffic Control Project, and this will be described later in the section.

So much for details of the course structure. The subject of Cybernation and Transportation itself can be considered in the following ways.

TRANSPORTATION - GENERAL PROBLEMS

Transportation can be thought of as a form of communication in which men and materials interact purposefully over a distance. A transportation network is the bloodstream of a modern technological society. In underdeveloped nations, poor transport is one of the major factors inhibiting growth and technical advancement, contributing, as it does, directly to the high cost of goods.

Wilfred Owen⁴ states that historically there are five stages a country will pass through to arrive at what could be considered a good standard of transport: a) a traditional, relatively immobile society, b) a period of internal improvement and trade growth, c) mechanization and industrialization, d) motorized mobility, and e) conquest of distance by air. There is growing sensitivity to the possibility that the most affluent nations, and the highly urbanized areas of the less affluent ones, may be entering a new stage of immobility. This identifies one of the central problems to be considered - how to secure mobility in a crowded urban setting.

To plan for a total transportation system is an incredibly complex undertaking. Apart from the not easily determinable decision about what the ultimate purpose, or purposes, of a transport system ought to be; the relationships to other priorities such as the need to modernize agriculture, to develop industries, to expand educational opportunities and to cleanse the air may be most subtle. Even if perceived, they are likely to be inexpressible in any quantitative way, because of a lack of sufficient

good data.

Should a country invest in refrigerator cars or food processing plants near the fields? What is the relative importance to a country, of intracontinental and intercontinental transportation ties? What limits does the domestic construction industry impose on transportation development? And, (of particular relevance to our studies), could an engineering systems approach contribute to the solution of problems associated with the attempt of a country to improve its transport? These are only a few of the kinds of questions which are relevant to the whole study.

Urban Transportation - Basic Questions

Structuring the complete transportation system of a country in the hope of finding optimum solutions is obviously a monumental task. One may expect to have a much better chance of seeing what help the newest technologies have to offer by narrowing the study down to a more manageable segment. Urban transportation in the San Francisco Bay Area, or even a smaller unit, could be an example of such a system. If transportation here is, in fact, not yet systematized to the point of being optimally manageable, at least the difficulties can be expected to be within the reach of comprehension.

The measure of the transportation problem in any large metropolitan area in this country is also a measure of an astounding growth and redistribution of population. The number of urban residents in the United States is estimated to have increased by 30 million from 1955 to 1965 and in the same period the number of motor vehicles more than trebled from 24 million to 85 million. A continuation of the trend at the present rate would place more people in urban areas by 1985 than the total 1965 population of the United States. Nor can we completely gather from these figures the bewildering interconnections which prevent an unambiguous picture of the problems.

What ought to be the relative role of the automobile and the public carriers? If parking charges are increased to reduce auto traffic in a central business district, will this not hurt downtown businesses? What are the effects of new transportation technologies on patterns of land use? How does housing segregation affect the nature of the urban transportation? How should relative costs of competing methods be assessed? What potential technological innovations should be considered in future planning? Will air pollution become a dominant factor in transportation decisions? Does it not seem likely that solutions for one area would

be quite inappropriate for another? The love affair of the average American for the automobile may have psychological overtones. Is the transportation problem of sufficient concern that one ought to seek out psychological means, using mass communication, to combat it? Can one identify the economic principles which relate to the costs of urban transport to other expenditures? If increasing numbers of people begin to use public transport, how will it effect present public transport difficulties?

Planning For Transportation

To seek the answers to these kinds of questions, a comprehensive planning scheme is obviously required. Some of the essential elements needed for such a scheme are summarized as follows along lines suggested by a Bureau of Public Roads Instructional Memorandum***50-2-63, issued September, 1963. ⁸

1. Economic factors related to community development.

There are many kinds of economic data required for realistic planning, some of which are available from government sources, and some of which need to be obtained by other means. Examples of useful types of information are:

- a) Employment data and projections, including the nature of industries in the study area, future industrial potential as a function of geographic and climatic features, characteristics of labor force, and relation of the local economic unit to the national economy.
- b) Income-consumption patterns for the area.
- c) Car ownership per household.

2. Population studies.

Population studies often tend to underestimate rates of change. There is great difficulty keeping the large volume of data current and relevant. Historical data, population distributions in both small and large areas, migration, changing birth and death rates, and other factors all need to be surveyed. Whatever the forecasting method or methods used, (simple graphical or mathematical extension of past trends, ratio methods relating a smaller area to a larger one, or more complex analyses of separate components of population trends), the computer has become an indispensable aid to demographic studies².

3. Land Use

For maximum utility, data on land use should be as detailed as resources allow. This means that the inventory should preferably identify the precise nature of individual commercial units; and wherever possible should count the smallest separate parcels except in homogeneous single-family residence areas where the cost may be prohibitive. All relevant existing governmental or secondary data sources should be utilized. The tax structure which influences the land use is also an important factor to consider.

4. Transportation facilities

The relative mix of privately owned and public transportation facilities may vary markedly from one urban region to another. Thus, Chicago relies heavily upon public transportation, but Los Angeles, very little. The kinds of information which need to be obtained about existing transportation facilities include the physical aspects of roadways, their classification by function when this can be determined, capacities of streets and intersections, and volume of speed of movement at rush and non-rush hours. Information about public transportation is ordinarily more readily obtainable, not only because the routes are on a regular schedule, but also because the various operating data concerning such features as running time and seating capacity are necessary for accurate accounting purposes.

5. Travel patterns

The study of patterns of travel, to a considerable extent, overlaps the inventory of transportation facilities. Figures for average daily utilization of various routes and means are not so useful as a determination of hour or hours of maximum demand would be. Supply must meet demand at these peak periods, but on the other hand, an oversupply of facilities and services at hours of light demand compound the difficulties of financing public transportation systems. General conclusions may be reached from data already available which point strongly to the predominance of the private automobile in urban transportation for recreation-social purposes or for irregular personal business trips, for which a flexible mode of transportation is preferred.

It is only for the regular work trip, particularly

to a population dense urban core, that public transit appears to be able to compete on any kind of a favorable economic basis with private transportation. For the future, however, evolving conditions associated with intense population pressures may cause new patterns to emerge. To forecast some of the possibilities, data relating to a variety of parameters such as the purpose and length of trip by various modes, the time of day, and the identification of terminal zones must be kept continually adjusted. Also preparation for the future dictates a consideration for the possibility of cybernation-induced unemployment. If the brunt of the unemployment should fall primarily on certain minority groups confined to the urban core, as is now occurring, the transit pattern may be difficult from that characteristic of a more generalized unemployment. Many variations are conceivable. In the latter case, perhaps even more than the former, some kind of broad-based income support may prove to be a political necessity. The movement of people could then tend toward a home-to-recreation pattern rather than toward home-to-work.

6. Terminal and transfer facilities

One of the serious handicaps that public transit often faces is a lack of adequate terminal and transfer facilities. An urban transportation analysis cannot legitimately overlook the fact that the commuter is concerned with the cost and convenience of his total trip between home and work. It is certainly true that a similar problem faces the driver of a private automobile as parking facilities in central business districts become more and more unsuitable, and insurance costs increase. This, of course, tends to narrow the competition gap between public and private methods under conditions of extreme congestion; but if the public terminal is located at an inconveniently long distance from work or home, the need for some form of feeder transportation arises. Planning projections must consider the possibilities of integrated systems to handle the post-terminal problem successfully, and make allowances for the incremental costs incurred by providing for local passenger distribution.

7. Traffic engineering features

The traffic engineer knows many ways of increasing the effective capacity of existing transport facilities. Many of the schemes are in partial measure intuitive and

commonsensical (even though they have been worked out in the context of engineering planning) and are in evidence on many streets and highways. Changing the pattern of traffic signals, eliminating parking on heavily traveled streets, and introducing through and one-way streets are all examples of commonly observed techniques. Having made the changes, the traffic engineer must then measure their success by determining the new volumes of traffic flow. In this, the computer can be a valuable tool. A research project of this kind, utilizing the computer, is described in some detail at a later stage of this major topic discussion.

The traffic research engineer is not, in fact, ordinarily satisfied with trial and error methods. He has developed empirical, mathematical and simulation models to synthesize transport networks and to allow predictions of change in certain variables such as delays at intersections⁷. Empirical models have been studied in which independent variables such as queue length are changed by, say, changing a light sequence, or by utilizing graphs or statistical analysis. These models relate observations on the independent variable with those on the dependent, whereas mathematical models make performance predictions on the base of certain assumptions. Queuing theory, time series analysis, and linear programming have all been used in mathematical modeling of traffic situations. Large amounts of data are required for empirical models, while the complexities of mathematical models make it difficult to study the effects of all the important variables. Simulation models, however, are more flexible, and have the advantage of displaying similarities to real traffic systems. Analog and digital simulation of traffic systems have both been reported. Certain interesting relationships between fluid flow or communication network theory and movement of traffic suggest a value in studying the respective analogies. Simulation on a digital computer permits the handling of large amounts of data with continual updating of a system having both deterministic and probabilistic components.

Attempts to validate simulation models in practical situations make one aware that the ideal simulation model has not yet been achieved. Still, the studies are important. They may, for instance, when sufficiently perfected help the traffic engineer to anticipate the effect of certain technical innovations upon the transportation problem.

The popular literature contains many references to imaginative ideas for facilitating the movement of people and materials, based on new devices and technologies. These articles are more dramatic than factual, one suspects, when he observes that it has been many years since there has been a major functional change in urban transport. Still, one should never underestimate our capacity for scientific and engineering ingenuity if social pressures for change become sufficiently demanding. Among the innovations which have been proposed¹ are the monorail and various other forms of high-speed rail transit; hydrofoils and ground-effect machines; short take-off and landing aircraft and electric cars. Other new ways of increasing the efficiency of travel by private and public vehicles include computerized guidance systems, expanded leasing arrangements and transit vehicles capable of operating either on rails or on uncontrolled highways.

Class discussion on transport systems of the future is invariable stimulating, but needs close reign to keep it out of the realm of the uninformed. The monorail, for example, has captured a good deal of popular attention. It is useful to let students know that the first commercially successful monorail line was built in Ireland in 1888, but there are still technical problems to be considered, such as difficulties of car-to-car articulation around curves, in switching, and in designing for stability.

8. Zoning regulations and building codes

City and county planning must exist before the forecasting of land use in urban and suburban area has any meaning. No study of transport capabilities should be carried on without careful consideration of existing ordinances and the possibility for change should it be needed.

9. Financial resources

One cannot ignore the overriding significance of the economic resources available in a given community to finance the kind of transport system which seems to be best able to serve its needs. Pricing policies are difficult to square with any pure economic theory. The "incremental cost pricing principle" which proposes that anyone should be allowed to have any service, if he be willing to pay the incremental cost of producing it, is subject to considerable modifying by imperfections on the market. If

pure efficiency cannot be the sole guiding rule, how far can one carry the ideal of service in over-all planning? How much subsidy, if any, is needed or acceptable; what is the funded debt of the governmental units; and to what extent can the regional government concept prevail for taxing and planning purposes? Financial planning for urban transit must consider these types of questions along with careful estimates of all potential sources of revenue.

10. Social Value factors

Given the turbulent climate of American cities today, any full-scale planning of transport systems has to recognize that new transport may itself be an agent for aesthetic and social change. Is it possible to improve the general social welfare by overriding the rule of the marketplace? The question is controversial and the answers not clear for every situation. Nevertheless, it would be foolish to ignore the need of providing for open space in future development; to foster "across-the-tracks" ghettos by inappropriate location of new transport arteries; or to destroy historical landmarks or points of natural beauty. Many planners are intrigued with the potential of "social accounting", which provides ways of expressing social values in quantitative terms. The use of these indicators in systems planning is not perfected but the possibility of assigning monetary significance to social propositions is intriguing because this may demonstrate to public officials who must make final decisions that there can be profit in beauty.

This last points up the importance of political considerations to every stage of the planning processes which have been outlined above. No matter how carefully analyzed and documented any proposed system of transport may be, it is still implemented in the end by political decisions.

Computer Usage In Transportation Planning

The foregoing sections have attempted to offer some idea of the complexity of information gathering and decision making in the design of a transport system. Where there is much data to be handled it is useful to ask, and especially so in a course like Cybernation and Man, what roles may the computer play in transport processes. Apart from the more obvious operational situations such as compiling and analyzing data, scheduling and operating

rail transit, etc., there is also an interesting function involved in some of the research planning.

To what extent can the computer serve as an acting partner in the design of a transport system, or elements of that system? There is an extensive literature, as the later bibliography suggests, describing a variety of approaches to transportation systems design and technology which point out some of the possibilities. Two examples follow.

Highway Location Analysis

Transportation research engineers are learning to use the computer effectively for analysis and prediction in many complex design problems. The earlier parts of this section on Cybernation and Transportation have indicated the uncertainty associated with making decisions which must take into account a variety of ill-defined options, and the effect of their many conceivable interactions on changing social structures. It seems clear that there can be no single best solution to the problems of a transportation system of any variability. Essentially the attack must seek alternative action plans, and then predict and evaluate certain of the consequences of these alternative courses.

The students' attention may be directed for the purpose of study and discussion to published reports by Manheim and Roberts and Suhrbier⁵. A theory of problem-solving processes, which utilize many search and selection sequences, is described. The system is being developed in the Department of Civil Engineering at the Massachusetts Institute of Technology.

One specific problem taken up³ concerns the location of a twenty mile stretch of highway in a given location. Twenty-six important requirements are identified each of which could be associated with a preferred route location. For example, the need to consider bridge costs would certainly require the seeking out of a route with a minimum of intersecting ravines or bodies of water. Other requirements could demand quite different locations. Some of the other requirements which Manheim lists, such as land costs, travel time, services and public financial losses may be more readily assessed in a quantitative fashion than others, like airpollution, eyesores, comfort and safety, and regional development. For each of the requirements a graphical representation of the area

being studied can be prepared showing light and dark areas of various shades, such that a black area or point indicates a desirable location for building the highway, while a white area should be avoided with respect to the given requirement. Computer-produced pictures of the moon's surface from direct sensing of a variable input of reflected light might suggest a crude analogy.

The computer can handle large amounts of data as input, and can also generate and display the images. Obviously for the determination of each of the several diagrams, the role of the computer will vary with respect to that of the human analyst. For one set of circumstances, a largely intuitive judgment may be the one most suitable; for another, formal mathematical procedures may be superior.

Combining all 26 of the diagrams is a hierarchical process in which the designer begins with certain small subsets of requirements which are photographically superimposed on each other to produce one solution. This process is repeated as a series of superimpositions of subsets until a final diagram is prepared showing, on the basis of the given assumptions, the preferred highway location.

This is only a brief look at a rather sophisticated study, and the student's interest in following up the details in the original papers will depend upon his academic background.

San Jose Traffic Control Project

When it is possible to observe directly the workings of an on-going transportation research project which utilizes a computer, the student can achieve a strong sense of involvement with the total problem. We are fortunate in having available for student visitation in San Jose, a traffic control project originally sponsored jointly by IBM Corporation and the San Jose Public Works Department. The study project, which was the first of its kind in the United States, began in June of 1964 initially to determine the functional and economic feasibility of controlling a traffic signal network by a central digital computer. The work is described in an unpublished report entitled San Jose Traffic Control Project⁶ written after the completion of the first stage of the project on December 31, 1966 and made available through the courtesy of

Mr. Gene Mahoney, the project engineer. On the site, the students are able to see an on-line map model of the intersections being controlled, to observe the computer arrangement, and to examine the programs and the data resulting from the studies.

Basically, the performance of the control system can be evaluated by certain criteria which reflect driver benefit and satisfaction. The required number of stops in the study area, queuing delay, trip time, density throughput and speed variation are all useful indicators of this kind. Of course, the variables influence each other, e.g., restriction of traffic in the control area could certainly reduce delays there, but it would also reduce the throughput of cars, obviously. This initial study concentrated on measuring stops and delays caused by traffic signals at 59 intersections.

The traffic control system is similar to all other closed-loop control systems in that it involved information gathering, decision making, execution and verification, and evaluation and adjustment. A system for controlling traffic does have specific additional needs. The information gathering must be continuous to handle momentary and long-range changes induced by accidents, weather, parades, new construction, etc., and so, obviously, must be the evaluation. Individual computer control for each intersection also provides for flexible decision making without requiring a physical changeover.

The diagram, Fig. 1 indicates the control loop relations.

The San Jose system, among other things, provides for the following:

1. Positive computer control
2. Accurate timing for each controller step
3. Synchronous phasing of all changes when responding to changing conditions or manual instructions.
4. Real time detection and counting of vehicles.
Storage of counts.
5. Detection of special functions such as fire station activities.
6. Automatic generation of traffic statistics.

A block diagram of the master control program is shown

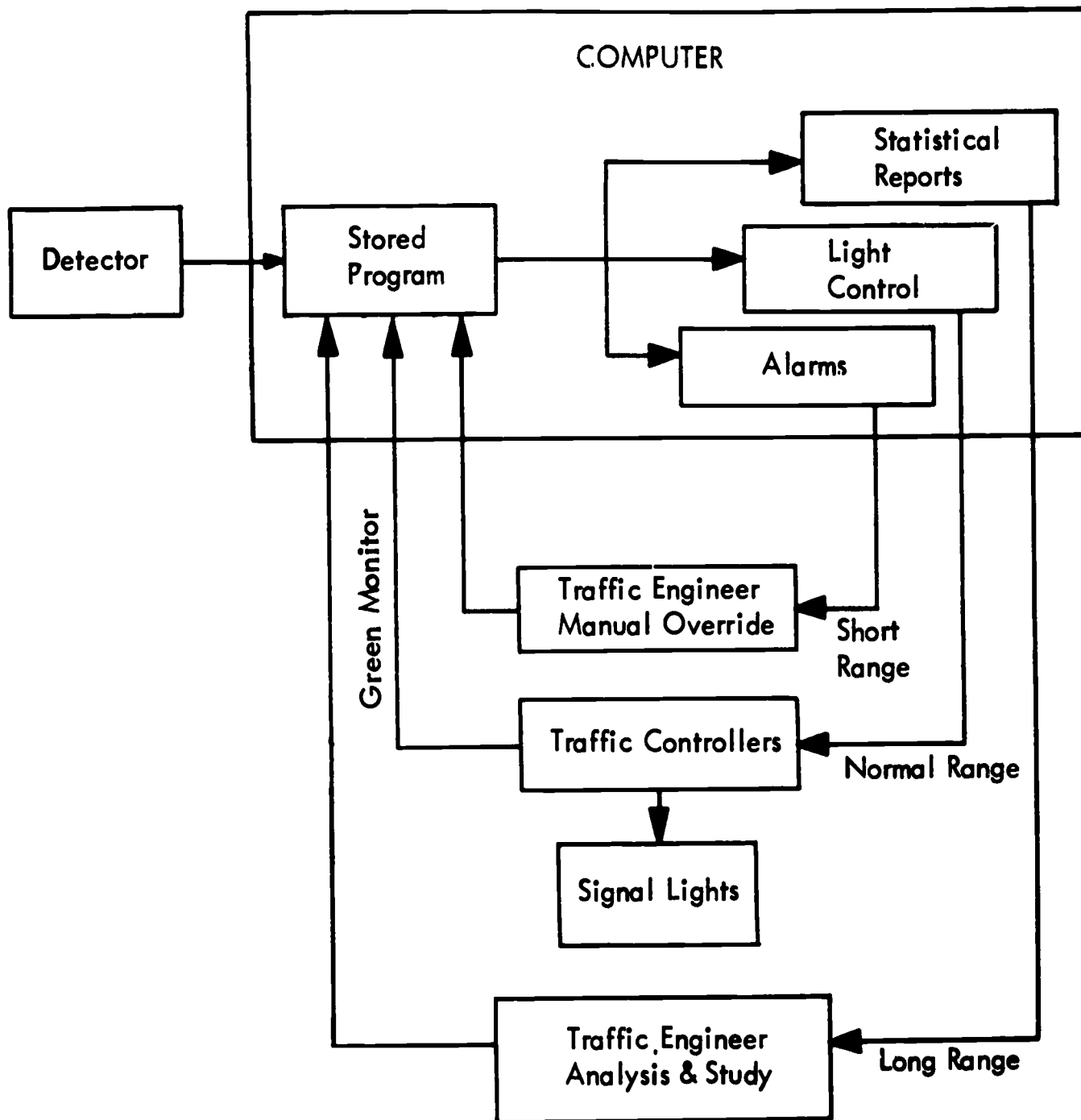

FIGURE I-1 CONTROL LOOP RELATIONS

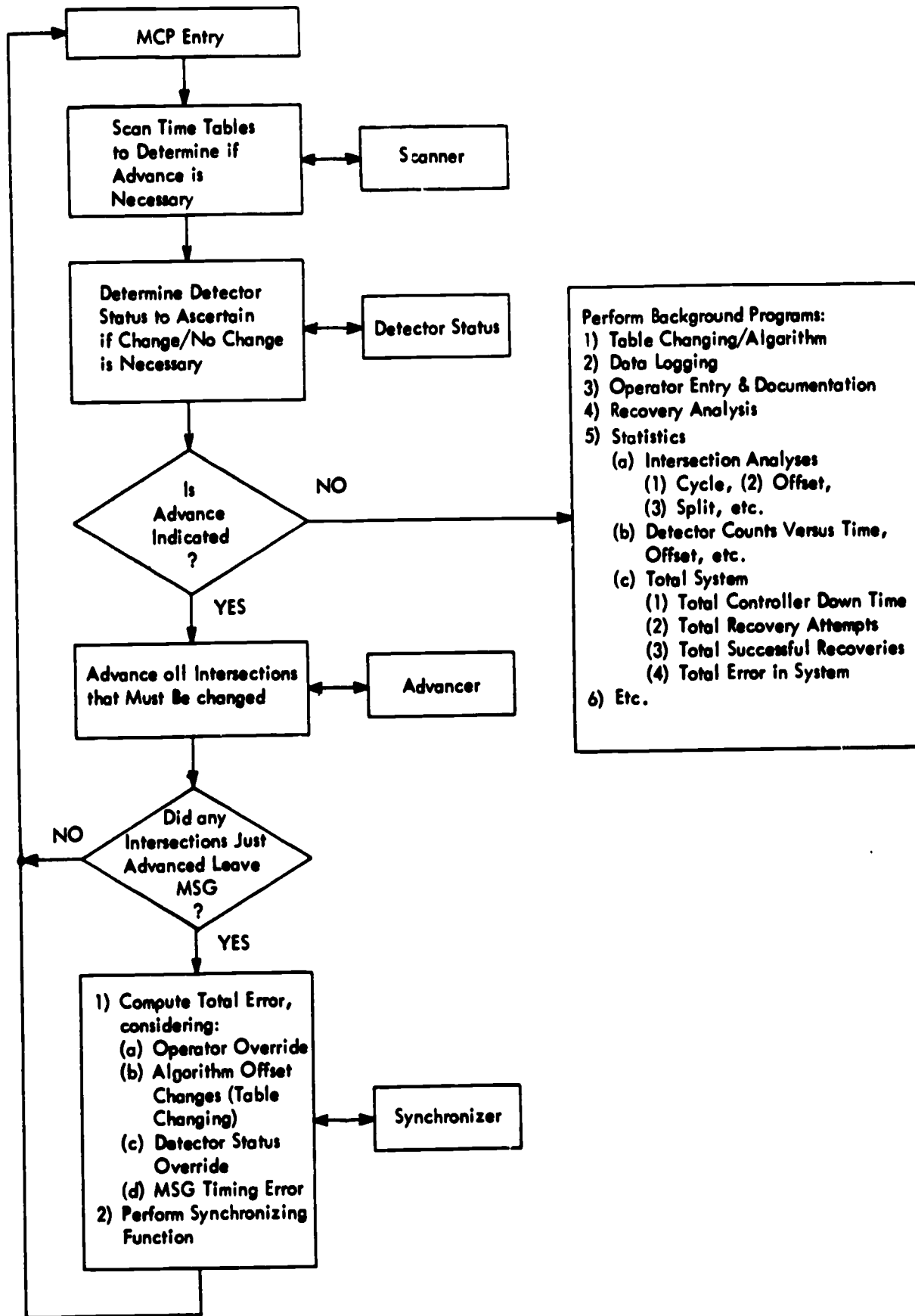

FIGURE I-2 MASTER CONTROL PROGRAM

in Fig. 2.

What have been the significant results to date of this program? Primarily, techniques were developed which have measurably reduced average vehicle delay, the probability of a stop, and the trip time of cars passing through the test area. For a control area containing 59 stop signals, the average delay per vehicle was reduced by 12% and the probability of a stop by 7.3%. Cost calculations indicated that these reductions resulted in an approximate total annual cost reduction of over \$300,000 for the motorists. In addition, the computerization adds control flexibility, evaluation capability and high reliability to the system and gives promise of further steady improvement by analysis and study.

By carefully observing this system the student can get a clearer picture of some of the promise and limitations of the computer when applied to a particular aspect of the mounting transportation problems of an urban area. He is then in a position to ask questions such as: On the basis of an analysis of the time, equipment and manpower required to carry this useful pilot study to a satisfactory state of operation, what kind of resources may have to be brought to bear on the transport crises of a large metropolitan region? Are there any indications that the political system can make resources of the necessary magnitude available? As the complexities of the systems grow and variables increase, to what extent may we expect that computer methods of analysis and control will cope?

The student will surely have learned that simplistic solutions will not do, and that the complex interrelationships which need to be untangled before an approach to a solution can be made cannot begin to be traced without taking advantage of the devices of technology.

C. CYBERNATION AND AGRICULTURE

The ages-old picture of the farmer as a creature bound to unremitting, hard physical toil is still a realistic one in many parts of the world, but in the highly industrialized nations technology and science are radically changing the face of agriculture.

In some ways, traditional farming as an enterprise seems the antithesis of modern industry. Industrial technology favors concentration of supplies, production facilities and markets; the distribution of available arable land, water and natural energy requires agricultural dispersion, and the changing of seasons fosters diversification. Mechanical industry demands precise scheduling and punctuality; but crops are not grown according to the clock. A cornerstone of industrial progress from the start has been the specialization of skills; while the farmer has had to be a jack-of-all-trades.

Now that the need to bring food production to a closer match with world population growth has reached critical dimensions, the technically developed nations, (the United States in particular), are counting on revolutions in agriculture to help do the job. The increases in agricultural productivity which have already been realized come largely from an infusion of industrial materials and methods. To students examining the effects of technology on society, many questions about these changes are worth asking.

What are the important relations between agricultural and industrial development to be considered in improving the economic situation in the emerging nations? Is the small family farm worth trying to preserve? What kind of place will systems analysis and computer technology have in the new agriculture? Is industrial farming wasteful of land and resources? What sources of food, other than the familiar ones, are there? Can impending famine in the impoverished lands be averted, whether by modernizing their agriculture or utilizing the bounty from highly productive farms in industrialized countries?

The last two questions are pivotal. Hopes for world order will be vanishingly small if large groups of people in important nations are starving. Agricultural experts express sentiments on this issue ranging from moderately optimistic to profoundly alarming. Contemporary technology and science, to be sure, realistically can be expected to continue generating strategies for identifying new sources of food and enriching the familiar ones. It is suggested by some⁴ that there may be an emerging science of world development based on quantification of resource variables. What-

ever patterns of development obtain they will most certainly have a technological foundation. However, in the light of surging population growth, there is reason to doubt that they will be sufficient⁵. Even though technology and science can themselves offer imaginative approaches to population control, the political and social realities are not easily brushed aside, and the need of the individual for children of his own surpasses rationality, sometimes.

Can science and technology develop synthetic proteins? Yes, this has been done, but primarily on a laboratory scale. Only one of the amino acids essential for human diets is being produced commercially. Many of the research approaches to synthetic food production are promising and even exciting, but the move to commercial production is as slow as the need is urgent.

Certain micro-organisms are capable of converting into scarce protein, more abundant organic materials, which can be taken from petroleum derivatives and other readily available sources but it is very difficult to do on a large scale.

What then about algae growing, or harvesting fish from the sea - can we find hope here? Yes, there is always hope, but in spite of reports appearing in popular and scientific journals for many years describing the possibilities and advantages of algae-culture, the processes have continued to be experimental. There is no indication that any large group of humans is ready to go on an algae diet. As for the fish culture, the ocean remains a largely untapped and little understood source of food and other natural materials. Is there any reason why fish cannot be cultivated and harvested in the same way as ordinary agricultural products? Probably not. Certainly there has been small scale commercial fish-growing in ponds for centuries. Carp-raising in China has been notably efficient. The fact remains that the primary method of getting food from the ocean at present is simply catching the fish. The ocean is such a bountiful source that scant attention has heretofore been paid to marine ecology and consideration of the replenishment of the supply by other than natural means. The "disappearance" of such varieties as sardines and herring from certain areas may be a warning that the ocean may not be an inexhaustible source. Much attention has been given to the use of fishmeal produced by grinding the whole fish as a promising major source of protein for the world's hungry. There have been obstacles to this program too - some medical or political, and some related to food habits or religious dietary restriction. Oceanography is now generally held forth as a source of hope, and there is the burgeoning belief that man's future is in the sea and from the sea. The fact remains that if we misuse the sea as we have, quite obviously, the land, the sea will

offer little future. Man's future, in terms of oceanography, is in his use of the sea; so that actually man's future is in himself.

On the land, we have not yet had to ask ourselves in this country whether we, in the sight of a calorie and protein-poor world can afford to feed so much of our grains to livestock when the yield of meat is so low in terms of relative food value, but that time may come.

To what extent can we count on opening up new, previously uncultivated areas by clearing forests, irrigating dry lands and fertilizing where the soil is poor in essential elements? According to a publication of the United States Department of Agriculture only 30% of the potentially cultivatable land in the world is now being used.⁹ Surely agriculture will expand into some of these areas, given time, but the obstacles are many. Much of this land is really quite infertile, and the amount of labor and soil nutrients which would have to be used to bring it into production would make the project economically unsound. Much of the land, also, is in tropical regions and there are special problems associated with tropical agriculture. Some of the basic crops which do well in the temperate countries fare poorly in hot, damp climates. The seeds are ill-adapted to the different climatic conditions, many plant diseases are endemic and insects, voracious. More research - a great deal more - is needed to develop crop strains which are hardy under these circumstances. Farmers, wherever they are, cannot or will not produce food for the market at a financial loss for very long. Water costs money, agricultural research costs money, and so does fertilizer. What is even more ironic and disheartening for those countries which are struggling to keep above a subsistence level, the relative costs of development for agriculture are substantially greater than they are in the industrially-advanced nations. According to Theodore Schultz⁸, the price of fertilizer in relation to the price of farm products is strikingly lower in Japan, for example, than in India. Rice farmers in India pay three or four times as much for a pound of nitrogenous fertilizer as Japanese farmers do in terms of their market price for rice.

Some are confident that most of the existing obstacles to the potential means of adding to the world's food supply mentioned in the preceding paragraphs could be overcome in time with a massive application of scientific, technological and industrial aid. Unfortunately, there are political and cultural realities to be faced as well. In some of the impoverished nations (perhaps most notably in Latin America) there are still large landed estates owned by relatively few wealthy people who are not financially

pressed to place the greater portion of their lands under intensive cultivation. Where these conditions exist there are generally heavy pressures on the government to redistribute the land. Sometimes land reform movements prevail, by revolution or by peaceful means; often they are resisted. But even when land is redistributed, the peasant farmers are not immediately prepared to operate their own plots by other than the subsistence methods which they know the best. Often agricultural yields are decreased. The governments in these countries are mostly ill-equipped to offer the financial and technical assistance required, and this job often falls to aid teams from the wealthier countries. From the standpoint of the need to produce more food in a short period of time, the maintaining of bigger land units where feasible (but fully supported with all of the technological structure required for large-scale agricultural production) seems to provide the more effective answer. Except that then there would be even less hope for the small farmer than now, and the drift to the teeming, explosive urban slums would become a torrent.

Pessimism is hard to avoid, but then one turns attention to the countries where agricultural scarcity has been effectively solved for their own citizens. What are the identifiable conditions which have resulted in agricultural abundance, and what are the new methods of technology which may insure for these countries a continuing increase in farm productivity? The statistics are striking. One clear indicator of the stage of agricultural development in a given country is the number of farms and farmers actively engaged in producing food. A sharp reduction occurs at a relatively late stage of a maturing agriculture. In the United States in the last 25 years, the number of farms has nearly halved as the average size of the farms has more than doubled. We require 50 million acres less to produce more food than we did 40 years ago. If the present rate of change continues, and it could conceivably increase, the number of farms could be projected to drop from about 3.1 million now to 1.5 million by 1980, and farm employment will halve while farm production keeps rising. One farm worker today produces food for 34 persons compared with 14 in 1945. ¹

This staggering productivity is a direct function of the application of science and technology with heavy investments of capital. First came mechanization, then electrification and now there is automation. There is automatic spraying, mechanical planting, fertilizing and harvesting, and controlled environments are available for poultry and livestock. With planters capable of working eight and twelve rows at a time, one man can seed 100 to 150 acres of corn or soybeans a day. This is 10 to 20 times

what could be done by mules. A mechanical harvester has been developed which can pick 15 tons of tomatoes per hour with a crew of 14 persons as compared with 1.5 to 2 tons per day for hand picking. This year nearly all of California's tomato crop will be machine harvested, and it should not be long before the necessary sorting will be done electronically on the harvesting machine. There is already a technique of electronic sorting used in lemon packing plants. The past two years have seen concerted attempts to unionize labor in the fields of California. There has been bitter strife, and no doubt one of the primary effects will be an increase in the adoption of mechanical devices by the farmers; although some crops such as certain fruits and nuts are inherently difficult to harvest mechanically.

At the beginning of this section it was suggested that there are basic differences between traditional agriculture and the mechanical industries which make agriculture less adaptable to automatic and cybernetic methods of control. Industrial history shows us however, that processes which are not by nature suited for automatization will often be reshaped so that they can be automated if the change appears economically desirable. We can see in the United States fundamental changes of this kind taking place in agriculture. Technological and scientific development go hand in hand. For example, a fruit may not be well suited for automatic picking because the individual fruits ripen over too long a period of time. For this reason, agricultural scientists develop a variety whose ripening span is foreshortened. Size, shape, toughness of skin and many other characteristics of agricultural products can be altered by plant breeding experimentation to meet industrial processing needs. Familiar varieties may disappear from markets to be replaced by new ones which are better adapted to production farming.

There are some agricultural economists who feel that the small family farm will no longer survive in this country for many more years. Instead, there will be huge corporate farms mass-producing food for the nation by factory-like methods. The trend is already very apparent. Not only are there large farms which have grown from small ones by acquisition of adjacent acreage in support of high efficiency operation, but also "conglomerate" corporations are turning to agriculture, confident that a cost-conscious management can return sizable profits. ⁶ Approximately 40% of the estimated 2.7 billion broiler chickens produced in the United States in 1967 have come from automated farms run by no more than a dozen corporations. It is true that poultry and egg production is especially suited to automation. In fact, poultry production has essentially moved off farms, and

into broiler factories not tied to the land. However, field crops too can yield high profits with labor saving machines, new fertilizers and efficient management. At least one corporation is making time-and-motion studies on farm operations.

Developments of this kind, naturally lead to examination of the most advanced types of supporting services to the new agricultural enterprises. The computer is bound to be used more as time goes on, and one can also look for increased application of systems analysis.

Electronic processing of farm management records for tax and accounting purposes in this country and Canada has been a fact for several years now, serving about 10,000 primary producers.⁷ This is a fairly obvious use of the computer for large scale operations. More innovative, perhaps, is an experimental program which has been described by Irving D. Canton.² This is a kind of computerized decision assistance service which his company provides to farm managements. It can be used to help the farmer decide on such things as the optimum crop mix and chemical spray combinations to be used for his own situation. The program required extensive data from each farmer, who, to be sure, must have adequate records. Soil test information, past maintenance costs for each piece of mechanized equipment, general cropping history and average rainfall for the area are all examples of the kind of input needed to prepare an effective program. The farmer will, of course, be interested in obtaining a maximum profit, and he may have the choice of planting a mix of several different crops to optimize his return.

It is no easy task to predict the selling price of the various crops for the purposes of calculation. The most effective way appears to be to use computer analysis of past price trends and supply-demand factors in combination with the independent predictions of consultants.

One segment of a much larger program describes the potential profitability for a corn crop grown on one 58-acre field out of 15 fields belonging to a farmer. A number of possible yields in terms of bushels per acre are listed along with required planting rates; pounds per acre (and cost) of nitrogen, phosphate and potash; machine and materials costs; and then total costs are compared with gross revenue to determine the crop yield which should produce maximum profit. Maximum yield and maximum profit may very well not coincide. These calculations are then compared with those for other possible crops such as soy beans or alfalfa grown on the same field. It may become apparent that planting corn for the maximum conceivable profit would not be possible because it would require more capital for fertilizer

than the farmer can make available. In that case, the other options would have to be considered.

Of course an efficient farmer with relatively small acreage could make these kinds of calculations without the computer, but as the size and complexity of the operations grow the numbers of variables and options become too difficult to handle. Other possible applications of the computer now in the developmental stage are being considered in studies of decision models which are expected to lead to improved ways of controlling unpredictable variables such as plant pests.

The average size of farms in the United States will continue to increase and as this occurs so will the need for professionally trained people skilled in a variety of fields to insure success in mass-scale agricultural enterprises. Systems analysis is beginning to be applied to industrial farming for management decisions - a predictable development in any corporate operation. It has also been suggested by Jensen³ that this approach to their research would permit agricultural scientists to reassess their goals with a clearer view toward future needs. He declares that systems analysis would have anticipated the mismatch between current cultivation practices and the leaf characteristics and size of the new short-strawed wheat varieties. These semi-dwarf types permit a higher utilization of sunlight, with the likelihood that rows could be planted closer together. However, there has not been adequate research on results with closely spaced rows in the past, nor is there a commercial way to plant them since drills in this country have a fixed row spacing of 7 or 8 inches.

Surely there are ways in which physicists, marketing specialists, agricultural engineers, plant breeders and others can cooperate to meet future food needs. The systems which must be studied with all available tools and talents encompass ecological factors related to man's whole environment.

We are still, in our Western countries, burdened with uncorrected blights remaining as a heritage of the First Industrial Revolution. The science of ecological systems is as yet not sufficiently advanced to assure us that we can avoid similar errors being committed in the name of modern industrial farming practices. In fact we have dismal evidence that some are. The build-up of pesticide concentrations in plants and animals is increasing, although the biological effects are not yet well understood. Fertilizers, too, used in large amounts can change the character of run-off into the streams and rivers, and, with other pollutants, feed thick growths of algae which rob the water of its oxygen. There are those who feel that the blanket of air

which surrounds the earth is being measurably robbed of the necessary oxygen to support human life by many processes including the defoliation and suburbanization of grasslands and forests. In this light, the large-scale microbiotic conversion of common hydrocarbons into protein becomes less promising, since this kind of process does not generate oxygen.

The prodigious productive efficiency which has resulted from the application of science and technology to agriculture in the United States has been a two-sided endowment. At a time when conservation of all resources to provide for the future of the earth's billions is a critical necessity, can we be sure that giant agricultural industries in fact offer the most efficient way to produce food either from the standpoint of continuous yield per acre, or yield per dollar spent for supporting materials and services? The farms of such countries as Holland and Japan provide clear evidence that high yields can be sustained on relatively small acreages. In these countries, of necessity, agricultural planning provides for a maximum return on resource utilization with a minimum of waste.

In the United States, as small farmers are forced to the wall, and their insufficiently productive lands lie unused or go under concrete there is nowhere for them to go but to the industrial centers to seek work for which they are too often unprepared. Perhaps, in time, systems will be developed in semi-rural complexes which combine industry and modest-sized agricultural holdings offering the optimum combination of productivity and livability. The prospect of designing this kind of social unit to meet demands of the future could provide a stimulating challenge to systems planners from many disciplines.

D. CYBERNATION AND THE ARTIST

In a course like Cybernation and Man, which seeks to stimulate communication and deepen understanding among the various academic disciplines, many uncommon interfaces are exposed. Few, at first, seem more unlikely than that between art and technology if we think of art as the most sensitive reflection of humanness - humanness capable of error and the creation of beauty and endless surprise. Technology, as embodied in the machine and its functions, even when (as it can be) closely engaged with human purpose, is designed for efficiency, speed and perfection - for eliminating the possibility of human error.

Art, of course, has always relied on some aspects of technology. The materials of the painter, the tools of the sculptor, and the instruments of the musician are all products of technology. The relationships between art and the new technologies, however, have become subtle and complex. Composers can use the electronic media to provide new dimensions of sound beyond the constraints imposed by the ordinary instruments. Since the camera can see more than the eye, not for many years have painters felt any necessity for concentrating their art upon a given subject from their visible surroundings. Now the electron microscope has unveiled a hitherto hidden inner world, so that the art of non-representation finds that it is duplicating other patterns of nature. But there is much more to it than this. The whole idea of human creativity is up for re-examination when the question "Can the machine create?" is asked.

Not all of the arts and humanistic enterprises relate to technology in the same degree, or in the same way. Discussing the relationships, an engineer or scientist may feel inclined to classify arts in order to define them. How to define, and whether or not the arts can be classified, are old philosophical questions.

Plato had fixed ideas of the arts as specific realms of being, and drew a firm distinction between the useful and the fine arts. Following Aristotle, the medieval scholastics made a like separation, classifying the humanities as liberal while assigning all manual activity to a category of mechanical arts. Hegel and Kant proposed systems of classification, but Benedetto Croce has said there can be no classification of an activity for which limits cannot be described.

Is art a skill or the product of that skill, which stimulates an aesthetic response in a beholder or listener - a special interest or a sense of beauty? Partly this surely, but

some can apparently be stirred in a similar manner by products of mechanical industry. Then, using this criterion alone, a machine duplicated automobile might be considered an artistic work. It appears likely that many artists would refuse to accept as art that which is completely machine-fabricated or composed, no matter how conceived originally. Possibly a mechanical product could be perceived as artistic more readily when removed from a utilitarian setting. An ancient urn (hand-made by a primitive technology, to be sure), would probably at first have had whatever beauty it possessed subordinated to its utility. Now shorn of serviceability, it can be appreciated by the modern day beholder for its grace, and the entire imagery evoked by its imagined history. Yet it does not seem fair, either, to deny entirely the fact of serviceability to a work of art. Perhaps the value should somehow be related to purpose, too. A case could be made for withholding the stamp of artistic merit from any creation whose purpose is destructive or totally commercial.

Art is also, along with science, sometimes said to be related to the pursuit of truth, but truth is elusive. While the artist may strive to project his moment into permanence, the vision of truth for one generation does not necessarily obtain for the next or the one after that. Is the glory of Mozart eternal? We would like to think so, but two hundred years is not eternity, nor does Western man necessarily set the style of taste for all of mankind.

And so we try to define or classify art at our own risk. The forms of art, affected by new tools, keep changing. Yet we must talk about the activity that people who are called artists, engage in. Art may be much else besides the creations of a Rembrandt, a Mozart or a Shakespeare but these we can unequivocally accept as art in our place and time.

In the Nineteenth Century the reaction of creative people to the Industrial Revolution was ambivalent. J.M.W. Turner and Walt Whitman each saw a kind of beauty in the powerful locomotives, while Charles Dickens wrote in Hard Times of "...vast piles of buildings full of windows where there was a rattling and a trembling all day long, and where the piston of the steam engine worked monotonously up and down like the head of an elephant in a state of melancholy madness." William Blake had earlier expressed his dismay, when he wrote of the "cogs tyrannic", yet he also sensed that technology would have to be used to deal with the new environment.

There were many artistic styles. Music and painting were surely affected by technology and the new industrialization, but the direct influence is not always easy to trace. It was often

a negation. The Romantic artists celebrated the freedom of the individual to express himself, and reaffirmed the glories of nature and the human spirit. A strong reaction to the bleak ugliness of mass-produced articles of the times was voiced in the arts and crafts movement which flourished in England in the latter part of the century. John Ruskin had been its prophet, and its credo was stated by William Morris. Morris wanted to reject the whole idea of mass production and to return to the principles of medieval craftsmanship.² The furnishings and other works made in his shops were aesthetically pleasing but the primary effect of the movement on the mass market was merely to cause some manufacturers to add non-functional embellishments to their machine products.

In the present century, extraordinary changes in the arts have accompanied the revolutions in science and technology. Planck, Einstein and other Twentieth Century physicists and mathematicians shook the orderly logic of cause and effect. Newton's majestic scheme of absolute time and absolute space was undone. The mechanization of transportation on the ground and in the air would make high-speed travel available to all. Space was to be explored to the fullest, and time to be considered in other terms.

The movement away from the representational which began with the Impressionists and post-Impressionist painters in the century just past became a quest for new means of expression. A subject in the visible world was no longer needed as a model. The Cubists, for example, in their works destroyed objects by abstracting geometrical elements, and then re-assembled them to give a sense of movement from a variety of contrasting but characteristic viewpoints.⁶ Art was experimental, but not always in the sense of a kinship with science and technology. Recognizing the importance that scientific developments were having on our culture, some artists were antagonized by what they felt was the self-involved and anti-humanistic attitude of science. Willing to try out some of the new materials of technology, they still had little use for any but the handicraft methods of production in their own work.

There surely were different points of view. The Futurists, in the time just before the First World War exalted the machines. Taking their cue from the Italian poet, Marinetti, they insisted that art was to be found in form as movement, with the spectator at the center. Dadaism, on the other hand shortly afterwards rejected the whole technological culture which could mount such a war, and questioned whether art could even have a function in that society.

In the succeeding decades of this century, up to the present one, numerous avant-garde movements have followed on the heels of

the one before, or existed concurrently. Sometimes painters use recognizable symbols for making social commentary, but the one predominant continuing pattern has been the flight from objectivism, the exploring of fresh means through various levels of abstraction. Stream-of-consciousness, atonality and randomness in the arts have not been popular with the masses of people, but the artist has had his own vision and iconoclasm has been worn like a badge.

However, in this current age of mass communications, the media voraciously consume, then disgorge, symbols and images, constantly seeking the new and the different. The unorthodox can soon become an orthodoxy. The viewing and listening public often tires of familiar faces and sensations. Artists, who may in the past have had no concern with a mission to communicate with a large audience can now become recognized even though comparatively few people know their works except by reproduction or reputation. All that may be required is a chance news story or a titillating television appearance, and another personality is discovered; his commercial success assured - at least for the moment.

The forces of commerce and technology are today overwhelmingly pervasive. Art, as a reflection of its times, could not remain unaffected by them if it would. The writer must deal with a language threatened by emasculation as words, lavished on trivia in a great flood of print and sound, begin to lose color and potency. Fact outstrips the imagination daily, and the novel and poem lose place to the report. The musician, for some time, has had a useful partner in the contrivances of electronics. The 1967 Pulitzer Prize for music was given to Professor Leon Kirchner of Harvard (described by Newsweek magazine as a musical conservative)⁴ for his String Quartet No. 3 which uses electronic sound on tape along with conventional stringed instruments. As the artist or sculptor seeks novelty and movement, he relies more and more upon mechanical devices and industrial materials for his effects. He develops assemblages of bus tickets, plastic foam and fireworks; "sculptures" of playing lights; and mobiles whose movements are controlled by unplanned interaction of their electronic and mechanical elements. This is not all new. In 1913, Marcel Duchamp mounted a bicycle on a stool and had a mobile. Thundering cannons with the 1812 Overture have provided a dramatic, if unsubtle, accompaniment to Tchaikovsky's music. For 30 years John Cage has searched for electrical means to make all of the sounds of the earth audible for music. What is new are the kinds and ranges of devices now available to the artist. High vacuum optical coating chambers, explosive-forming processes, hi-fi amplifiers, television and plastic forming machines have all been used.¹ If Marshall McLuhan is right and technology is an extension of the human body then nothing should

be more natural. If it is also an extension of the mind, the electronic computer would seem to have a rightful place in the act of creation. It is to the computer that some artists, and technologists and scientists associated with artists, look for help with some of their most eventful works.

In the interaction between technology and art, the computer is of special interest, because, as stated at the beginning of this section, some of the unresolved questions about machine "intelligence" come into sharp focus as we examine its role in artistic creativity.

"Can the computer be used in the creation of art?" We have not been able to define art very satisfactorily, and would have little more success with a definition of creativity. Perhaps in the context of the foregoing discussion, the question might better be put "Can the computer be used in the production of works which by general critical standards are considered artistic?" leaving for the moment the dilemma of the professional critic in setting standards for the art of today. One implied part of the question seems easy to answer when referring to the present generation of computers. They cannot now be expected to develop an original artistic work, since they must initially be programmed by a human being. However, in association with an ingenious human, the computer has already given fascinating evidence that it can help produce novel experiences of artistic merit. A. Michael Noll has described methods of programming through special purpose languages which permit an artist to produce visual images. More of the experimental work along these lines seems to have been done by engineers and scientists (often working with artists) than by artists alone because of the complexities involved in programming. So it may be assumed that these experiments have not ordinarily pushed art to its creative limits.

Noll has provided two intriguing illustrations of computer paintings which very closely resemble works by recognized artists. One is an example of "opart", a great deal of which relies on mathematical patterns. The computer handles such problems readily, and in this case produced a sinusoidal wave form with a linearly increasing period, which gives an overwhelming impression of motion. To a casual observer, at least, it is virtually indistinguishable from Bridget Riley's "Currents". In the other case, one of Piet Mondrian's paintings is used for comparison. Mondrian dealt with space in starkly geometric terms. His "Composition With Lines" is made up entirely of vertical and horizontal black bars within an outline that is apparently circular except for a slight flattening on the periphery at ninety degree intervals. Certain observations were made about the pattern of placement of the bars and their relative lengths

and widths, sufficient to allow the generation by computer of a similar composition, with pseudorandom numbers. It is interesting to note that when copies of Mondrian's painting, and the one produced by the computer were shown, unidentified, to 100 people of widely differing backgrounds, 59 preferred the somewhat less orderly computer-produced picture. If Mondrian had had the computer available to him in 1917, possibly many of the tedious details of bringing his idea to completion could have been eliminated. We do not know whether the idea of saving time would have interested him, nor can we tell whether he would have been as satisfied with the final result.

It has been over ten years since the first piece of music was composed by a computer. In the intervening time there has been a constant increase in the amount of experimentation being carried on. Some of the research has to do with such tasks as printing scores, cataloguing or making statistical analyses on certain features of the works of various composers in order to compare their styles. If we are primarily concerned with questions of creativity, then the work being done in musical composition is of the most interest. Furthermore, it is also apt to be more rewarding than computer research on the creation of visual arts or literary works, because of the smaller number of symbols to be manipulated.

Music in the Western world has for the most part evolved as composers have found ways of eliminating accepted constraints; thereby reducing the tendency toward repetition of certain conventional patterns. Some constraints are obviously necessary. A totally random sequence of notes would be achingly dull to the human ear. Nevertheless, within the framework of a few established rules of composition (perhaps characteristic of a given style) a randomly selected succession of notes can result in the production of acceptable melodies. The computer can generate random notes with great rapidity, unrestricted by limitations under which conventional instruments make sound; but also having some limits of its own at the moment. Fink² has described the experiments conducted a few years ago at the University of Illinois which resulted in the first substantial work of computer music. Strongly imitative, the work nevertheless pointed to significant new directions in music composition. The composer, with the aid of the computer, can now produce cascades of sound never before heard. These sounds at first have seemed strange and unfulfilling to human ears, but also interesting and at times, stimulating. Computer composition is still very expensive, and somewhat inhibiting to the composer because the computer cannot be "played" in real time. However, certain other more traditional factors inhi-

biting his output are being overcome. The studies are also producing new insights into musical theory.

Attempts to write literary works by computer have followed along lines sketched by students of communication theory.⁸ It is possible, for example, to construct sentences which resemble English by cutting all of the words out of a long, standard English text, placing them in a box, and then drawing them out in a random fashion. Usually "meaning" is just tantalizingly out of reach in the new text, but, sometimes the results are amusing or provocative. Given certain patterns of input, a computer can string letters and words together in a random sentence-generating program with great rapidity so that many surprising word orders appear. Language, however, is a uniquely human instrument, capable of evoking a vast range of images. It would seem beyond the power of any presently conceivable computer to write a genuine literary work.

What, in summary, can be said about the artist in a technological world? First, the artist has experienced, as Landau⁵ puts it, "a great return to the bosom of man." The Romantic notion of the artist-as-individual, aloof from the mass, could not really be expected to survive in an age of technology, when the huge resources of public communication force artists to interact continually with each other and the whole culture.

There are some artists today who still find the need to retain some measure of recognizable symbolism to give force to their commentary on modern society; but there are many more who see no need for symbolism. For them reality resides in pure structure. In a world without object, representation of objects is irrelevant. The plunge into abstraction has fostered an impulsive experimentalism which has led further to action art, found art, and even the happening. Is this art or anti-art? Can there be art without purpose or direction? If art has become a succession of random experiences, then could not the computer produce a valid form of art? Is there any critical judgment of modern art that can be respected?

It is not only the Philistine, but the humanist who asks these questions. Perhaps this is not surprising, since the humanist is often more comfortable looking toward the past. There are articulate artists who do not shy from the implications of this kind of question. Discounting the poseurs among them, they are sure that the artist, no less than before, is especially alive to the times in which he lives. Each generation has had its own conception of art. What other response, they ask, can an artist have in a time in which matter has become an aspect of energy, in which man can no longer hide from his collective brutality, and

his fouled environment closes in on him? In an age of cybernation when work loses its significance, perhaps the artist's individuality must be submerged, and his role must become one of sensitizing all men to the artistic experience in their surroundings, to sound and movement, and even to their machines.

One who does not profess to be an artist does not know the answer to these questions. He may, however, find it reasonable to suppose that if an honest art is possible in an age such as ours, then surely there will be fine artists among us. Their art will be a true reflection of our time, and perhaps the most prophetic indication of the future.

REFERENCES

The following references are cited in the texts of the three preceding topics in Part I and are identified by the appropriate number. A more generalized bibliography, including some relevant films is found at the end of Part II.

Cybernation and Transportation

1. Berry, D. S.; Bloome, George W.; Shuldiner, Paul W.; Jones, John H. The Technology of Urban Transportation. Evanston, Ill.: Northwestern Univ. Press. 1963. 145p.
2. Beshers, James M., editor. Computer Methods in the Analysis of Large Scale Social Systems. Cambridge, Mass.: Joint Center for Urban Studies of M.I.T. and Harvard University. 1965. 207p.
3. Manheim, Marvin L. "Problem Solving Processes in Planning and Design," Design Quarterly, 66/67. 1966. p. 31.
4. Owen, Wilfred. Strategy for Mobility. Washington, D.C.: The Brookings Institution. 1964. 247p. p. 35.
5. Roberts, Paul O., and Suhrbier, John H. Highway Location Analysis: An Example Problem. Report No. 5. Cambridge, Mass.: The M.I.T. Press. 1967. 224p.
6. San Jose Traffic Control Project: Final Report. San Jose, Calif.: City of San Jose - IBM Corporation. 1967.
7. Traffic Research Corporation. Intersection Simulation Model Validation. Pts. 1 and 2. Report to the U.S. Bureau of Public Roads, Contract No. CDR-11-2863. San Francisco, Calif.: Traffic Research Corporation. December 1, 1966. Pt. 1, pp. 1-205. Pt. 2, pp.1-84.
8. U.S. Bureau of Public Roads. Instructional Memorandum - 50-2-63. Washington, D.C.: U.S. Bureau of Public Roads. September, 1963.

REFERENCES

Cybernation and Agriculture

1. Ball, Charles E. "The Quest for Plenty," Engineer. VIII, July-August, 1967. p. 14.
2. Canton, Irving D. "More Services for Farmers," What's Ahead for the Family Farm. National Farm Institute Forum. Ames, Iowa: Iowa State University Press. 1966.
3. Jensen, Neal F. "Agrobiology: Specialization or Systems Analysis?" Science. CLVII, September 22, 1967. p. 1405-1409.
4. Meier, Richard L. Science and Economic Development: New Patterns of Living. Cambridge, Mass.: The M.I.T. Press. 1966. 273 p.
5. Paddock, William, and Paddock, Paul. Famine 1975! America's Decision: Who will survive? Boston: Little, Brown and Co. 1967. 276p.
6. Prestbo, John A. "Farmer Brown, Inc.," The Wall Street Journal. LXXVII, August 9, 1967. pp. 1,8.
7. Rowe, A.H. "Electronic Processing of Farm Management Records in the United States and Canada," Quarterly Review of Agricultural Economics. XX, January 1967. p. 39.
8. Schultz, Theodore W. Economic Crisis in World Agriculture. Ann Arbor, Mich.: University of Michigan Press. 1965. p. 45.
9. U.S. Department of Agriculture. Analysis of Facts Associated with Differences and Changes in Agricultural Production in Underdeveloped Countries. Third Progress Report on Participating Agency Agreements between AID and ERS. U.S. Department of Agriculture. July 20, 1965. p. 27.

REFERENCES

Cybernation and the Artist

1. Davis, Douglas M. "Art and Technology - The New Combine," Art in America. LVI, January/February 1968. p. 29-31, 34-37.
2. Fink, Donald G. Computers and the Human Mind. Chapter 12. Garden City, New York: Doubleday and Co. 1966. 301p.
3. Gideon, Siegfried. Mechanization Takes Command. New York: Oxford University Press. 1948. 743p.
4. Junker, H.L. "Electronic Music - 'wiggly'," Newsweek. LXIX, May 22, 1967. p. 98-99.
5. Landau, Jacob. "Yes-No: Art-Technology," in Dialogue on Technology, edited by Robert Theobald. New York: The Bobbs-Merrill Co. 1967. p. 91-102.
6. Myers, Bernard S. Understanding the Arts. Revised edition. New York: Holt, Rinehart and Winston. 1964. 502p.
7. Noll, A. Michael. "The Digital Computer as a Creative Medium," IEEE Spectrum. IV, October 1967. p. 89-95.
8. Pierce, J. R. Symbols, Signals and Noise. Chapter 13. New York: Harper and Row. Torchbook Edition. 1965. 305 p.

PART II

The Computer

PART II

A. INTRODUCING COMPUTERS

Most teachers have learned a speech technique for starting a lecture to a class called the "rhetorical question." We suspect it has been used so often that students are quite bored when the teacher starts his course in Algebra by saying: "What is Algebra? Algebra is the branch of mathematics that ..." We have done the same thing so often that we were tempted here to say, "What is a computer?"

The natural urge by teachers to vary their style has prompted us to ask our cybernation and man class if they have ever used a computer. It was surprising how many have. In the San Francisco Bay Area (the 100 mile long megopolis on the west coast of California) many high schools have made their small computers available to students in special courses in programming or as part of the senior year of mathematics. It appears that computers are not strange to the younger people in this area.

We have tried to reestablish our position as leaders of the class; the position teachers have historically held, by asking if any of the students have talked to a computer. We knew what we were leading up to but did the class? We have all assumed that when talking to our car because it won't start, or by talking to the bowling ball so that it will change course and knock down those pins, that we are in effect talking to ourselves. This wasn't what we were referring to.

One clever student said he had talked to a computer. He had visited a local computer research laboratory where they had a device designed to convert speech sounds into electric impulses that could be recognized by a machine in a distinct pattern and form. This in turn could be used to control a computer. This could be considered talking to a computer, and in turn the computer reacting or indicating a response to the voice.

"Could a computer talk to a human?" There we go again with the questions. Look up the word "VODER". This was a device invented by some clever people at Bell laboratories over 30 years ago. Can you make a connection between the question and the "Voder" in the light of modern day computer use? With this information, now, you too can ask a deductive question one that will lead your audience to a specific topic which you have prepared yourself to lecture about.

Some other questions come to mind, such as: "Can Computers

repair themselves? "Can Computers reproduce?" "Can Computers see or feel?"

What is the next most obvious question? You will notice that it is a human characteristic to compare other things to ourselves. We establish our authority and relative importance in the universe by proving that only humans can do "human" things. Who, or what, is comparing us and on what basis are we being judged adequate or inadequate?

The next time you hear someone, talking about computers, say, "You can always pull out the plug", consider just how secure they are about the man-machine relationship.

The real problems of the computer in man's environment are complex and ever changing. To be concerned and informed is necessary and the primary reason for the course "Cybernation and Man" at San Jose State College. As a persons "knowledge appetite" is whetted, the means to satisfy this desire is thorough reading and then supplemented by film, TV and audio tapes. At the end of this section, we will list books in our collection. This could be helpful to those having a large library available, although I'm sure there are many other books available on this subject that we have not seen or that will be published tomorrow. Our first report has a larger section devoted to a listing of films and audio tapes.

We also must recommend that those interested in computers watch the TV program "21st Century." It is excellent and most informative. Some special commercial programs produced by IBM and others are also good. In addition the education TV series by "NET", Canadian and British documentaries are very good; don't turn them off. We have also heard several radio programs conducted by university stations and tape broadcasts of panel discussions about computers, that were very good.

All teachers know how to search for and use 16mm films for classes. These films are very good and are, of course, designed to effectively put across a certain subject and concept. Some of the movies we have used are listed in section seven of our first report.

Any one who lives within driving distance of the next Spring or Fall - "Joint Computer Conference" should take two days from any activity except a marriage or the bosses birthday party, and attend. This twice yearly conference has two prime features, the presentations of papers and the demonstrations of equipment. We have learned more about computers in a day at these confer-

ences than we could in a month at the college. As an example, we attended a section devoted to "The Computer and Music" at the San Francisco meeting. The papers presented, the demonstrations and the discussion that followed left us with a completely new area to think about. We were fascinated by what lies in the future and our knowledge about music has been expanded considerably by this experience. Take two or three young people with you to the next computer conference and double your enjoyment, watch how quickly they discover and accept the new things in this world.

The following sections of this report are designed to help teachers understand the basic functional parts of computers, some examples of how computers are used and a very simplified series of lessons on programming. The sections on the computer and programming are taken from our classroom notes and could be used for other similar classes. The programming section features Fortran language because it is most useful and most used with small and medium sized computers.

B. COMPUTERS -- "DOING MACHINES"

An inaccurate quotation of Confucius might be "Some people do, some people think". We have heard and read much concerning the debate about computer "thinking". "The giant brain," "the ability of computers to play games," "Big-Brother computers," and many other similar comments frequently used to imply that electronic computers can think like a human. It is more appropriate, but possibly not so interesting, to describe the computer in terms of its other important characteristic, that is, the ability to do a great amount of routine calculating in a hurry. It can do a lot, do it accurately and do it quickly. We could call it a doing machine.

Computers are very fast. It takes a computer only micro-seconds of time to do an arithmetic calculation that we would take hours to do in our brain. Table 1 in the appendix shows a more accurate time schedule for one operation for various sizes of computers.

A computer is not only fast but also very versatile. It can do many different things by combinations of its very simple basic functions. In section "E" is a partial listing of some of the current uses of computers.

Some people think that the computer has limitless capacity for processing information. This is true in a sense, because a computer could be programmed to continuously take in inventory data, as an example, and constantly calculate purchasing orders. For a large organization such as Sears, Ford, Standard Oil, etc. such a computer could be set up to do just such a job. The amount of data being processed on a computer in full use by a large organization is beyond comprehension.

A computer really accepts two distinct things for processing. It will require instructions on how to process the data and the data for processing. Most digital computers are called stored program computers. This means a computer has an appropriate mechanism to take messages into its system and store them. These messages are coded to describe the precise method of processing the data.

In a simple form this would be a set of instructions saying add the number of each piece of data to the total accumulated and store in some memory section for future reference, and repeat. This could then go on for 100 pieces of data or one million. Whatever the number, the instructions to do the job would vary little.

A computer can accept into its system the data (any amount) and instructions to process the data in any combination or complexity. All of this then leads us to one kind of definition of a digital computer. It is a very fast and complicated versatile machine that can process large amounts of data by accepting and storing the instructions, as well as the data needed for the problem solution.

Getting into the heart of the computer we find that its simplest cell is an "on" - "off" unit. This means that a computer, when you get right down to the core of its operating mechanism, or circuit, can only operate in the binary mode. The basic function of the internal circuitry is to close or open a circuit, or detect a closed or open circuit.

The above, of course, is a simplified version of the many ways in which the binary mode can be activated or detected but it will serve to demonstrate how the components of a computer are organized to take a simplified binary condition and by compounding and adding these together very complex systems can be developed.

A digital computer can sense, by its electronic elements, some form of a "1" or "0". This can be interpreted as "yes" or "no" and "+" or "-". The "1" and "0" when taken in various sequences will represent numbers and letters of the alphabet so that words can be formed. This becomes the vehicle by which humans can communicate with this machine. Let's consider a simple example:

$$01100 = 12 = \text{twelve}$$

binary decimal English

The binary code can then be read, from right to left, to mean "off", "off", "on", "on", "off", In the exact numerical form this would then be:

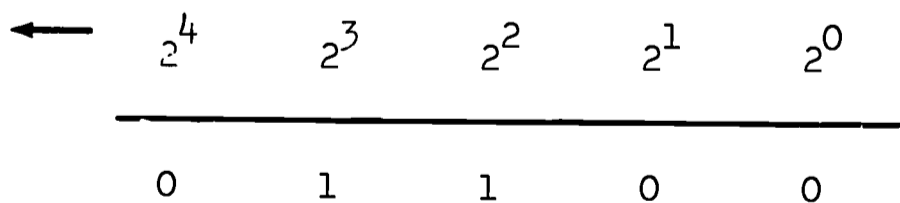

FIGURE 1. BINARY SYSTEM OF NUMBERS

In decimal equivalent this means:

2^0	=	1	none	
2^1	=	2	none	
2^2	=	4	one	4
2^3	=	8	one	8
2^4	=	16	none	
				<hr/>
TOTAL =				12

A little later we will explain binary numbers in greater detail.

With very complicated combinations of the basic ability to do this simple binary recognition a computer can:

- 1.) Perform very complicated scientific numerical calculations.
- 2.) Do word, or literature, searches, in contrast to number listing and sorting.
- 3.) Keep inventory information, update and report.
- 4.) Simulate complex systems such as "industrial" processes.

In summary we can say that of the thousands of computers now in use there is a major group that can be classified for descriptive purposes. This broad general class of computers have these basic characteristics:

- 1.) General Purpose
- 2.) Stored Programs
- 3.) Digital and
- 4.) Electronic

This then can be the definition of digital computers as used in this report.

C. FUNCTIONAL UNITS OF A COMPUTER

The general purpose, stored program, digital computer that is electronically operated can cost up to several millions of dollars. Those of medium size or smaller, used by many schools can be rented for several thousands of dollars per month. Table 1, appendix, shows how large, medium and small computers can be classified on the basis of their memory size. The memory capacity is a factor in determining cost so that in general large machines cost more than small machines.

The complexity of the circuitry and mechanical components in a computer need not concern the average user. Just as most of us drive an automobile well without knowing the compression ratio, volumetric efficiency of the carburetor venturi or the method of valving the hydraulic fluid in the automatic transmission, we can operate the computer without full knowledge of the inner complexity of these machines.

All computers may be divided into five areas of operation and the schematic diagram Figure 2 shows the functional relationship of these units.

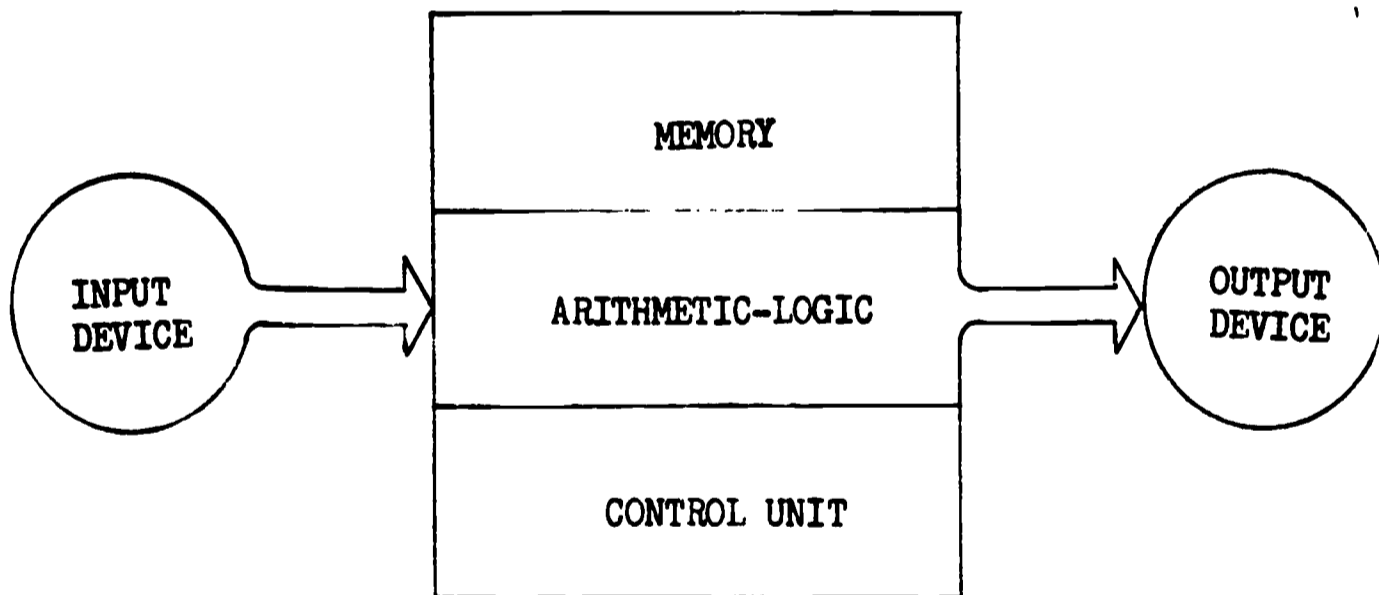

Figure 2.

Schematic Diagram of The Main Functional
Units of A Digital Computer

a. Input devices

The input unit provides a means of entering information into the computer. Since computers are electronic the design of a device to communicate with the memory will necessarily be in the form of electric impulse generation. The input unit must deliver to the computer's memory a sequence of electric pulses patterned and timed in such a way as to be binary and with a fixed and understandable code. Our former example of a binary coded word "twelve" could be sent to a memory unit, such as a magnetic disc, in this voltage pulse form.

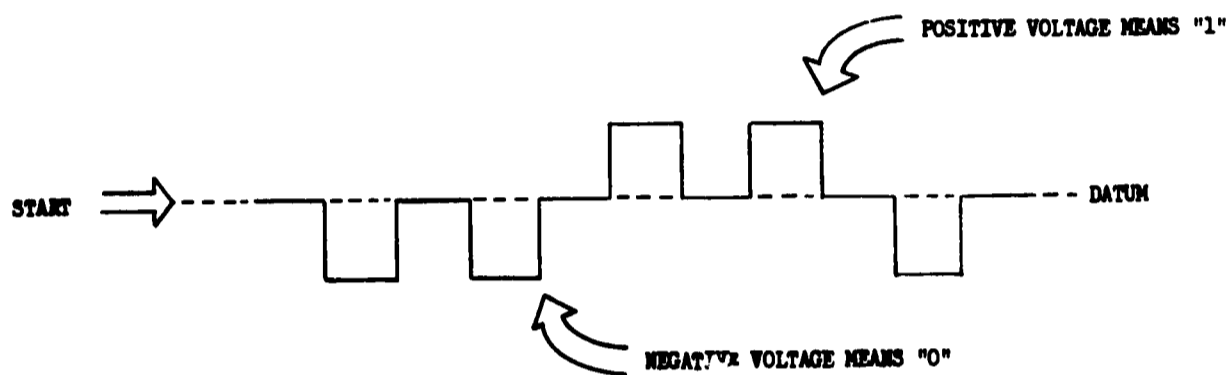

FIGURE 3.

In this example, the train of impulses is used to indicate a binary code for the word twelve which is recorded in a memory unit, such as a disc, as magnetic spots. We'll go into more detail on how these spots can store information later.

Two fundamental types of messages are sent from the input device to the computer memory; data and instructions.

b. Media for input

Six types of input media are used in popular forms of computers. They are:

- 1) Cards (punched cards with Hollerith code)
- 2) Magnetic tape
- 3) Paper tape
- 4) Magnetic ink characters
- 5) Cathode ray tube and light pen

6) Handwritten material optically scanned and read

All of these must be sensed and converted to electric pulses.

There are two types of cards in use today, the common IBM and the Remington Rand. The reader for the IBM card moves the cards over a contact roller with brushes that sense the holes in the card. When a contact is made through the hole an electric pulse is sent to the computer. The Remington Rand type is passed through a photo-electric arrangement that senses when light passes through a punched hole thus sending an electric pulse to the computer. Of course, this is a simplified explanation of the difference between these two types of cards, but it does show the basic difference in the way they are used.

All characters on an IBM card are read at one time. There are 80 columns and 80 brush contact sets. Cards are easy to handle, fairly reliable and inexpensive. They may be sorted, collated and merged apart from the computing machinery. If an error occurs on a card it can easily be replaced by a corrected one.

The reader for cards is fast; for the #1620 IBM computer up to 800 cards per minute can be read or over 1000 characters per second.

Paper tape is a ribbon of paper about $\frac{1}{2}$ to 1 inch wide with holes punched through in a coded sequence. The tape is read about the same as a card is read and the electric pulses are signals sent to the computer. The advantage of paper tape is its low cost, easy handling rolls and reliability. The speed in reading or punching is slow and errors are very difficult to correct.

Magnetic tape is similar to paper tape in that it comes in a reel but holes are not punched into the material; instead, magnetic changes are induced by a special electric head similar to the familiar tape recorder. Tape can be read by a special drive and read mechanism at a rate of about 20,000 to 300,000 characters per second. In addition tape can be read in both the forward and backward directions; this makes the tape very versatile and convenient to handle. Large amounts of data can be put on a single reel of tape and read into a computer very rapidly. A single reel of tape, 10 $\frac{1}{2}$ inches in diameter, can hold the same content as 250,000 punched cards. The only disadvantage is the very high cost and complexity of the mechanism to handle the tape.

Magnetic ink characters can be read into a computer much the same way as tape is read. The additional advantage is the fact that humans can read the characters as well as the computer's input

device. The most common use of this special medium is on bank checks. The disadvantage is the mishandling and frequent errors. For most computer use, the reading of these characters is subject to extensive checking and in some cases the information is transferred to tape for input.

Optical scanners are now available that will read numbers and letters directly from the surface of the paper. One recent extensive development in this technique is the Post Office ZIP CODE reader. This machine reads ZIP CODES from handwritten and typed letters and sorts them automatically.

Another form of optical scanner is the cathode ray tube with the light pen. In this arrangement the light pen is used to put lines or points on the face of the tube. The tube in turn acts as a sensing device which sends electric pulses to the computer. This of course, is a very highly sophisticated way of getting information into a computer. It is expensive and slow therefore used in only special design applications.

Most computers have, in addition to the usual card reader, or tape deck, a typewriter which can be used to put information into the computer. The keys on the typewriter are connected to switches which arrange to give the right pulses for numbers and alphabetic characters. Although this method of input is convenient it is far too slow for most uses.

c. The Console

The console of a computer is the control station. Most computers have such a station arranged so that the operator can control the input and output, watch the operation by checking signal lights and intermediate information signaled to the typewriter by the computer. At the console of a medium size computer the control buttons for starting and stopping the computer, the typewriter for input and output of intermediate information, the display lights that indicate the contents of certain registers and certain other functions of human control are located.

d. Memory Unit

One of the main developments in modern computers has been the information storage system called the memory. When the information has been coded for storage it is in a binary form therefore the units we will describe here are all of this type.

Memory units are divided into cells; each is capable of holding one character. The simplest cell structure is one that can hold one bit (binary digit), sometimes called "bite", either a "0" or a "1". These cells are assigned addresses in a sequential manner. The addresses are used to designate where in the memory characters are to be placed or found. Characters are usually not manipulated one at a time, but rather in groups called words. Word length varies according to the type of machine, some are called constant word length others called variable word length machines. Table 1, Appendix shows how some present day computers are arranged by word size in the memory unit.

Two important characteristics of memory are access and capacity.

Access time: refers to internal speed of transmitting information to and from memory units and to and from arithmetic logic unit and memory unit.

Capacity: refers to characters or words, the number of words that can be stored in the memory unit.

Working memories are small in capacity but have extremely rapid access time. These are usually core and are generally located at the console or very close by.

Auxiliary memories are large in capacity but slow in access time. These units can not be used directly with the arithmetic-logic section but must transmit or receive all information through the working memory as shown in the following diagram:

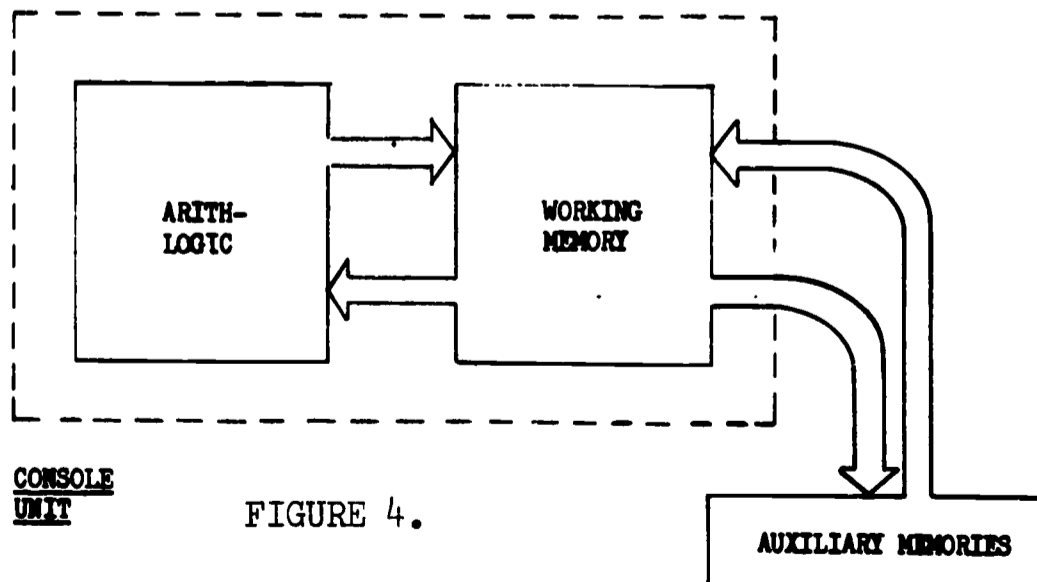

FIGURE 4.

Auxiliary memories are usually disc or tape of some form.

e. Drum Memories

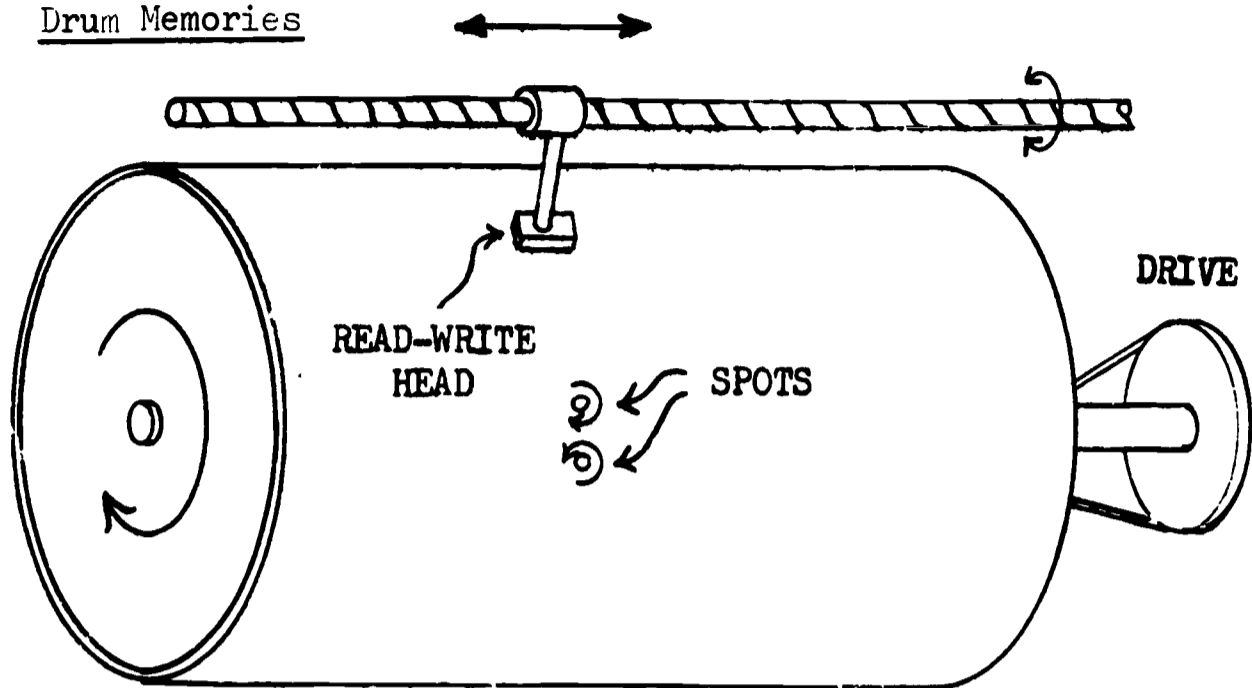

FIGURE 5.

Schematic arrangement of a typical magnetic drum memory.

A drum is a metal coated cylinder. The coating is the surface upon which information can be recorded in the form of magnetized spots. The spots are placed in areas formed by a uniform division of the surface into rows and columns. The spots can be magnetized with either north or south polarity and therefore can be used to represent the binary digits, "0" and "1".

The drum rotates at a constant speed passing a set of read-write heads once in each revolution. A read-write head, by producing a magnetic field, can create magnetism of particular polarity in a particular spot. In other words, it can "write" coded information on the drum. The read-write head can also sense the magnetic polarity of a particular spot; that is, it can "read" coded information from the drum. Writing destroys existing information, replacing the old with the new, whereas reading is non-destructive.

The capacity of a drum memory is limited by the size of the drum and the code used. The access time depends on how fast the drum revolves and upon the placement of information in locations which will be near the read-write heads when needed. Average access time is calculated as one-half the time required for a full drum revolution presuming that on an average, information will be

located one-half a revolution from the read-write heads.

f. Magnetic Disc Memories

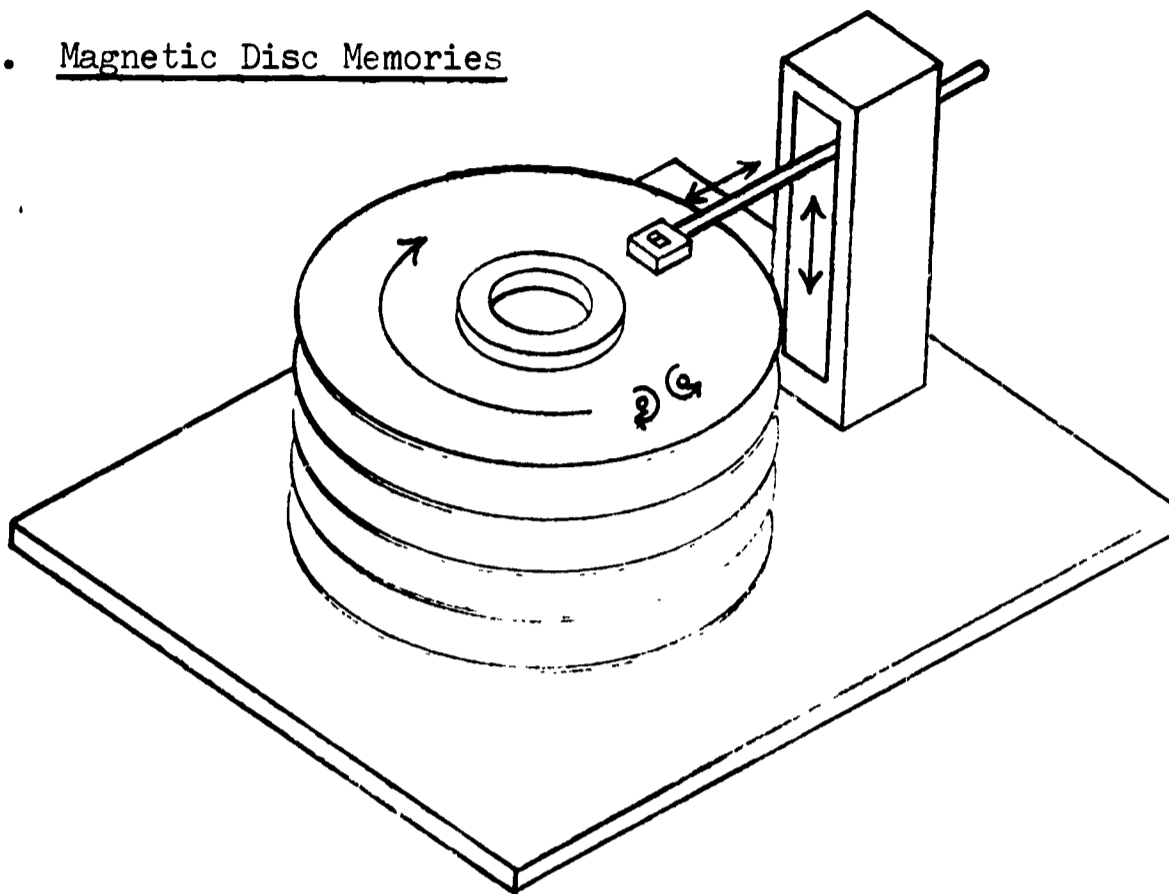

FIGURE 6.

Magnetic disc stack in diagrammatic arrangement.

A magnetic disk is like a thin metal phonograph record coated with a ferrous oxide material which provides a recording surface. Whereas phonograph records have on each side a continuous spiral groove, the recording surface of a disk is arranged in concentric rings called tracks, each having an address. The tracks are sub-divided into addressable locations. Information is recorded in specific locations of specific tracks as spots of magnetism in the surface following the same principle as applied to drums.

Disks are not used separately but are arranged in stacks mounted on a vertical spinning shaft. The shaft spins the disks at a constant rate of speed. An access arm fitted with two read-write heads, one for each side of a disk, is mounted vertically beside the stack and is capable of moving to any track on any disk. Once in the proper track, the revolution of the disk brings the desired location to the read-write head. Writing on the disk is destructive, and reading from the disk is non-destructive.

The capacity of disk storage depends on the number of disk stacks, the number of disks in each stack, the recording density of each disk, and the code used. Access time is the time required for the access arm to move to the proper disk and track and for the addressed location to revolve to the read-write head. Access time can be decreased by the use of more than one access arm; one for each disk is the usual arrangement.

Disk memories can be expanded by the addition of disk stacks to a capacity of $\frac{1}{4}$ billion characters. The access time varies between 100 to 800 milli-seconds. This capacity is considered quite large, but even though it takes less than one second to find a location, the access time is considered slow in comparison with desirable access times for a working memory. Large capacity is the outstanding advantage of disk storage.

g. Ferrite Core Memories

A ferrite core is a ring about the size of a sharp pencil point which can be magnetized to either north or south polarity. An electrical impulse sent along a wire which passes through a core will magnetize the core. The direction of the impulse determines the magnetic polarity which is easily described as being either clockwise or counter-clockwise, "0" or "1". This magnetic state remains unchanged until an impulse sent along the wire in the opposite direction reverses it.

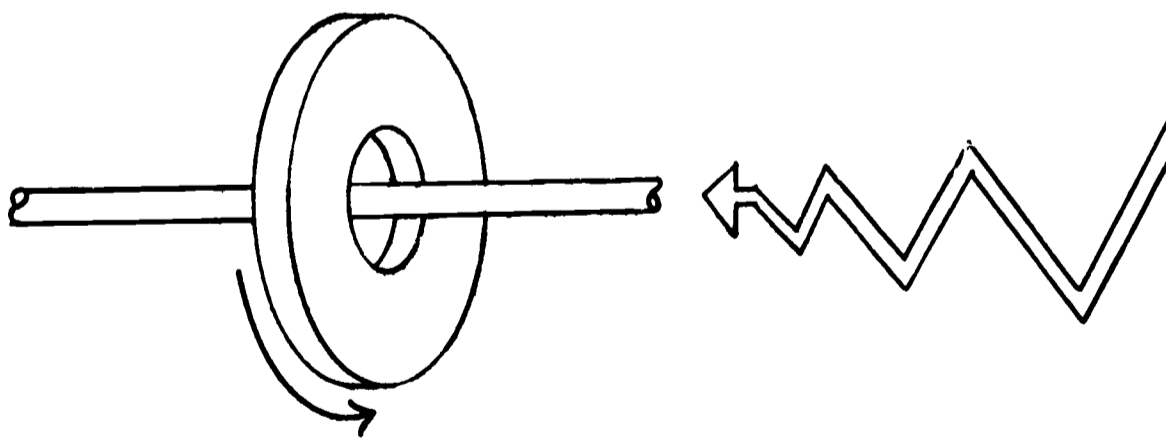

FIGURE 7. A SINGLE FERRITE CORE

A magnetic core plane is a two-dimensional array of cores strung on wires over which impulses pass controlling

and sensing the magnetic states of the cores. Although the cores in a plane are strung on common wires, it is possible to select an individual core in which to create a "0" or a "1" magnetic field (write) or from which to sense a "0" or a "1" (read).

In order to be able to establish a particular magnetic state in only one of the many cores in a plane, each core is placed at the right-angle intersection of two wires. One-half the required current is sent over each wire, thus producing sufficient current to affect only the core at the intersection.

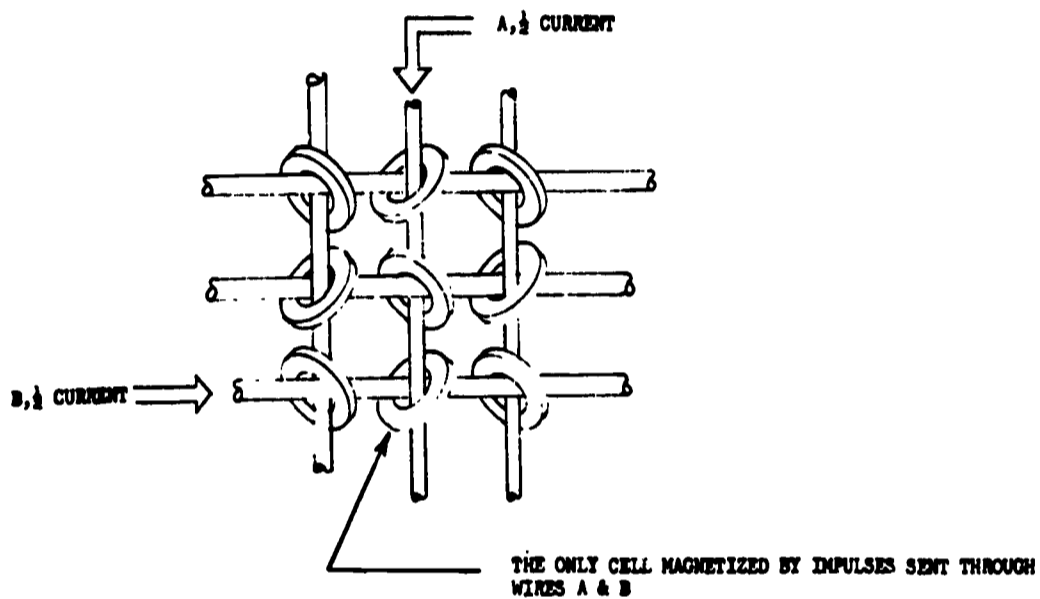

FIGURE 8. A CORE PLANE

To read the magnetic state of a core, three wires are used, the two just described (for clarity call them "A and B" wires) plus a third one called a sense wire. One sense wire passes through all of the cores on a plane.

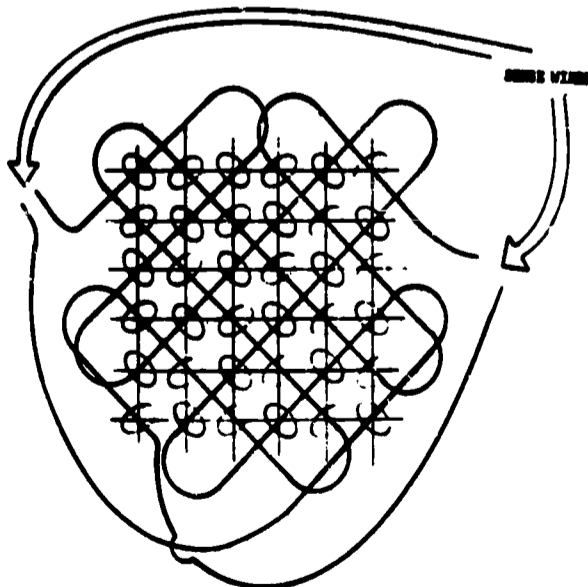

FIGURE 9. SENSING SYSTEM FOR CORES

Impulses are sent over the "A and B" wires as for writing. If these impulses cause a reversal in the magnetic state of the selected core, the sense wire will conduct a pulse induced by that reversal. Such a reversal of the magnetic state of a core, however, is destructive. To overcome this, a fourth wire called an inhibit wire, which like the sense wire is strung through all of the cores in the plane, is used in conjunction with the "A and B" wires to restore cores to their original condition. Thus the final result of reading is non-destructive.

In a typical ferrite core memory the planes are placed one on top of the other in a three-dimensional arrangement. The number of planes in the stack depends on the word size and the code used. A cell is the group of cores in one line similar to the one shown in the diagram below:

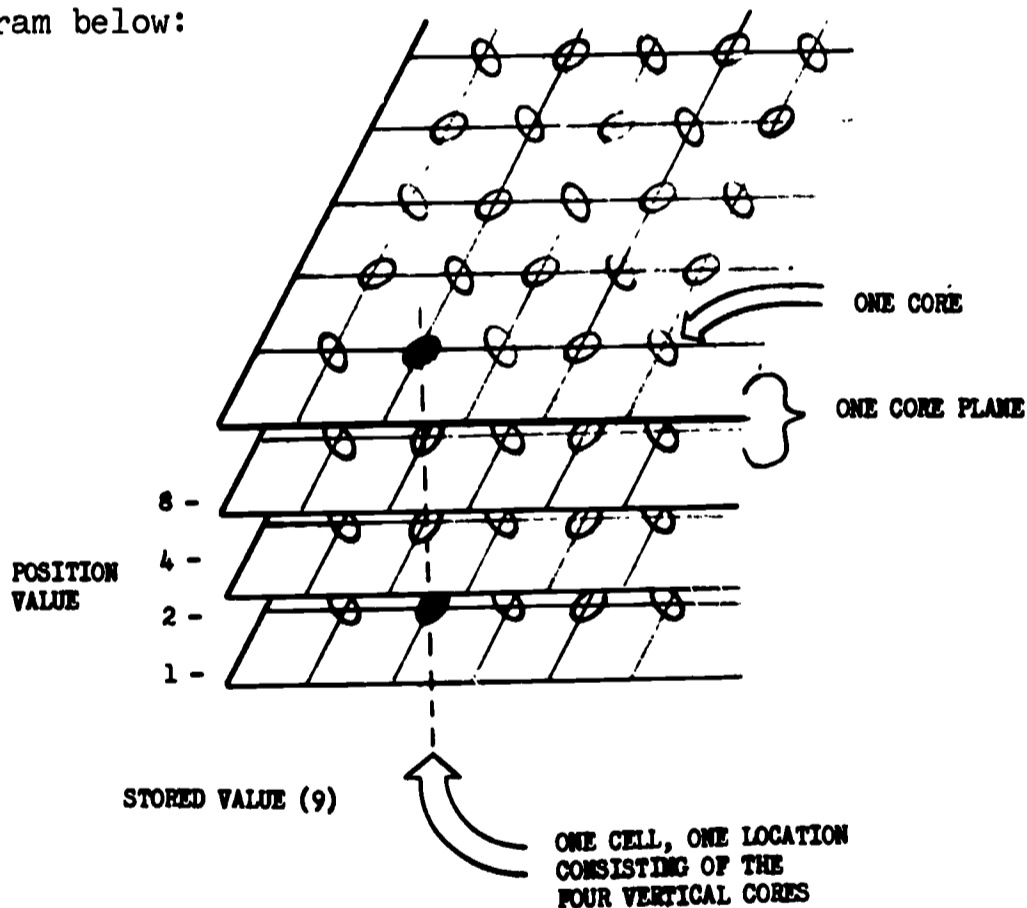

FIGURE 10. CORE STACK

Stacks such as shown in the diagram the size of a package of cigarettes would have over 150,000 tiny ferrite cores and all the wire to connect them in it. The access time to any cell would be less than twenty micro-seconds.

h. Magnetic Tape Memories

One of the newest forms of memory units is the Data Cell which is simply the arrangement of strips of magnetic tape and read-write heads set up as shown in Figure 11.

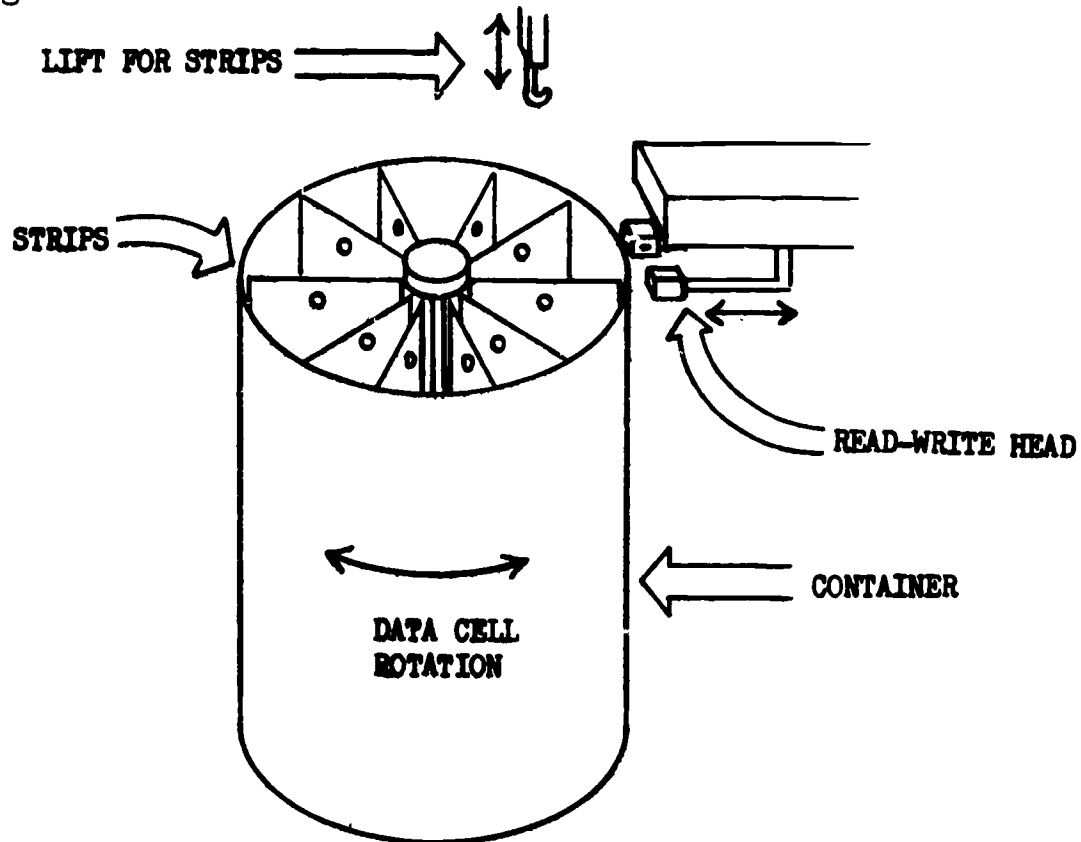

FIGURE 11.

Schematic arrangement of magnetic strips in a Data Cell.

This type of memory unit is only used as auxiliary memory. Its capacity is over 3 billion bits but its access time is slow. To take information from the cell requires a rotation of the container until the proper strip is in line with the lift mechanism. Next the strip is lifted from the container as the read-write head moves over the surface when the strip is in the proper position the read section of the head senses the cell's magnetic state.

i. New Memory Devices

The development of memory units so that more words can be stored in smaller spaces continues every day. In addition many engineers are constantly working on improving access speed. Not many people can really keep up with these developments but the most promising of new memory systems appears to be the laser beam. A trillion

bit memory unit is already in operation and with such new means as the hologram and laser a quadrillion or larger unit will be made soon.

j. Arithmetic-Logic Unit

The desk calculator of the computer is the Arithmetic-Logic Unit. This is the register where the addition of numbers takes place. Combinations of adding and subtracting, the negative of adding, and multiplying and dividing are accomplished by this section. In addition to doing arithmetic operations this section is arranged to recognize negative and positive signs of numbers.

k. Control Unit

All of the circuitry necessary to control all of the operations of the computer are included in the Control Unit. This section could be called the "brain" of the computer. When a program is stored in the memory, one command at a time is brought to the control unit where it is interpreted and then executed. The entire function of this unit is as follows:

The control unit receives, interprets and executes commands and

causes the operation of

1. INPUT
2. MEMORY
3. OUTPUT
4. ARITHMETIC-LOGIC

It also governs the transmission and storage of all information within the computer.

It coordinates the functions of the various parts of the system.

e. Output Unit

The output section of a computer is very similar to the input. In most cases after the program is executed the control section arranges for electric pulse signals to activate the output unit. This could be in the form of

a punch mechanism which will put holes in cards or paper tape. In other cases this output can be in the form of a special printer that acts like a fast typewriter. In some cases the typewriter itself acts as an output device.

Cards punched by the output mechanism can be read on a card reader and printer. This machine reads the punched hole card and prints one line at a time on a roll sheet of paper.

The Cathode Ray Tube (TV type) is also a common means of displaying output information from the computer.

D. PROGRAMMING COMPUTERS

After studying the basic anatomy of the computer, the next logical question would be: "How and why should anyone communicate with a computer?" Well, it must be remembered that computers are affecting your life more and more each day. They are rendering service to you, and you are probably not conscious of what service is being rendered. For example, if you have a checking account, in all probability the computer is keeping track of the amount of money in your account. When you write a check, the amount of the check is automatically deducted from your account. The computer also keeps track of the number of checks you write and computes a service charge which is deducted from your account. This is one form of automatic billing. If you have a charge account, the computer keeps track of how much you have charged during the month. A bill is sent out at the end of each month which itemizes your charges and gives you a total for the current month and adds any other charges carried over from the previous month along with an interest accumulated on the unpaid balance. This too is a form of automatic billing. Other forms would be gas bills, telephone bills, electric bills, etc. All of this is done by a computer.

Now it is your turn. Find two other computer applications which affect your daily life.

1. _____
2. _____

(Print your answer - it will be good practice for the coding coming up later)

The most popular media used to communicate with the computer is by punched cards. There are other methods of communications; but, for the moment, let's devote our attention to punched cards. Looking at a standard Hollerith card (IBM card), we find that it has 80 columns, numbered 1 through 80; and it has 10 rows, numbered 0 through 9.

(See Figure 12 next page)

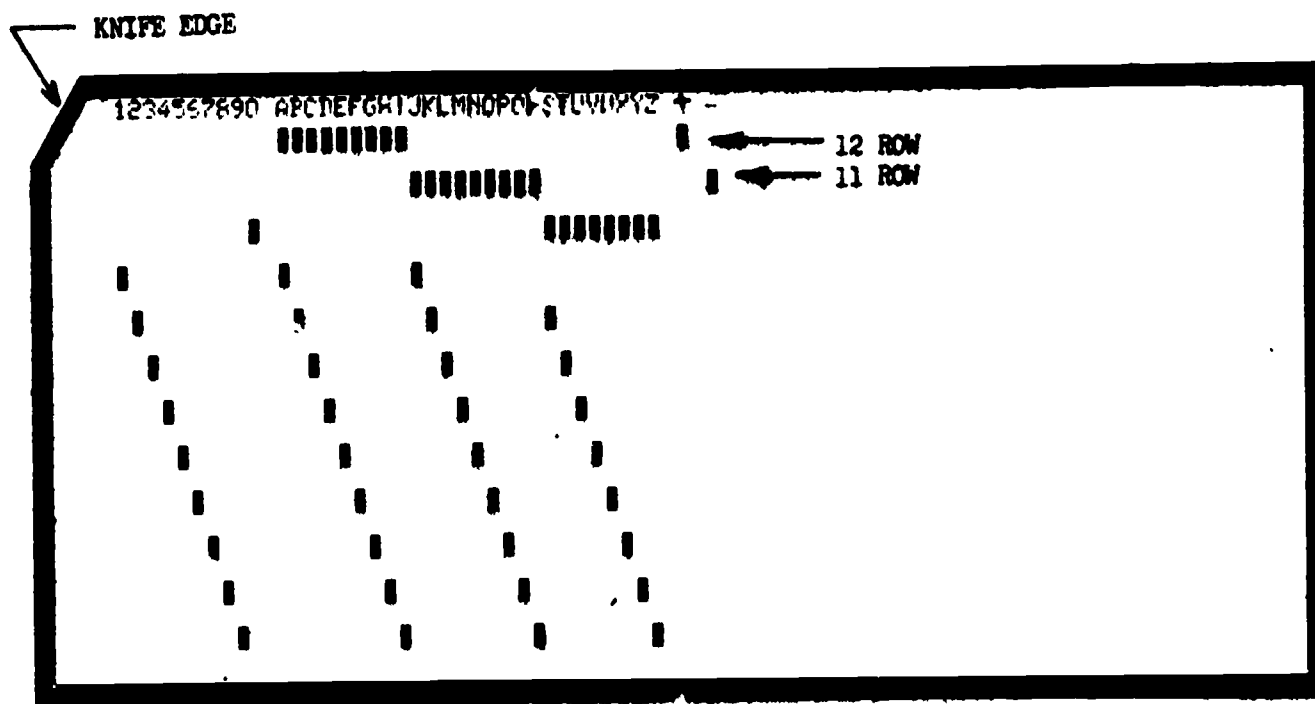

FIGURE 12.

Standard Hollerith Card

Actually, there are 12 rows as shown in Figure 12. But, the "11" and "12" rows are not in the normal order and are used for the alphabetic characters, and special characters. Now, looking at Figure 12, the very top edge, you will find the number system and the letters of the alphabet, and + and -. Under each character is a hole (or holes) which uniquely describes that character to the computer. So, the computer is only interested in the presence and absence of holes. Anything else that appears on the card such as printing, color, knife edge, etc., is provided for the convenience of the human being. The things that must be remembered is that there is only one line of print on a card, and that when an error is made in keypunching, the whole card must be discarded (unless you want to sit and plug up the hole where the error was made).

The short description given in the previous paragraph provides the reader with some of the basic features of the punched card which you will need to know later.

a. Description of Programming Languages. The first programming language was the machine language, or the language that the machine uses. This language is made up of numbers because that is the only thing the computer can work with. Depending on the machine, there are a set number of digits that makes up what is called a machine language "word", see Figure 13.

Such words are stored in the memory unit of the computer.

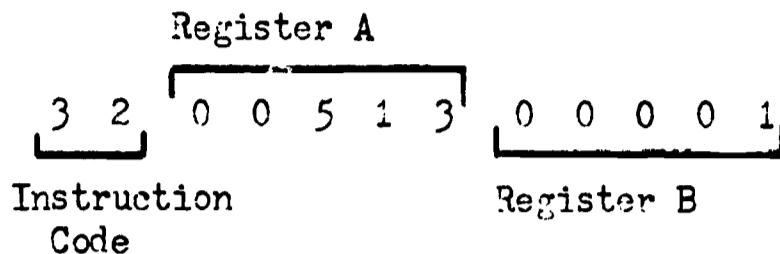

Figure 13 Machine Language Word

This is done at the time when the card reader reads the punched card. Suppose that the numbers shown in Figure 13 were punched into a card, and that card was read by the card reader. The card reader has to read the whole card, or all the information contained in the 80 columns. The reader temporarily stores the information into Buffer A. Then, the reader reads the card again and stores the information into Buffer B and compares the information in Buffer A with the information in Buffer B. If the two buffers are not in agreement, the reader rejects the card, signals the human operator to correct the card, and stops. If the two buffers agree, the information is sent to the computer control unit which takes all the information and temporarily stores it. The control unit takes the first 12 digits, or first word, and puts the first two digits in an Instruction Register, the next five digits in Register A and the next five digits in Register B. Then, the control unit "looks" at the Instruction Register and "sees" the number "32". To this particular computer, this number might mean "take the next word and store it in memory location 513, and take the contents of Register A and add it to Register B and store the result back in Register A and do not alter Register B, and repeat."

Now, it shouldn't take the reader very long to realize that machine language is very nice for the machine; but, machine language isn't very understandable for human beings. Because the human being dislikes "painful" operations, he designed a machine language program that would recognize and translate alphabetic characters into other machine language words. He called this machine language translation program an "Assembly Program." So, now he could punch the information shown in Figure 14 on six cards, take the Assembly Program and put his cards (program) behind the Assembly Program (see Figure 15), and be assured that his program would be executed properly.

Col. 1-3 Card #	Col. 15-30 Command	Col. 35-50 A Address	Col. 55-70 B Address
1	RDCARD	CARDAREA	X
2	RDCARD	CARDAREA+1	Y
3	SUBTRACT	X	Y
4	STORE	X	
5	STOP		
6	DATA		

FIGURE 14.

Program Coded in Assembly Language

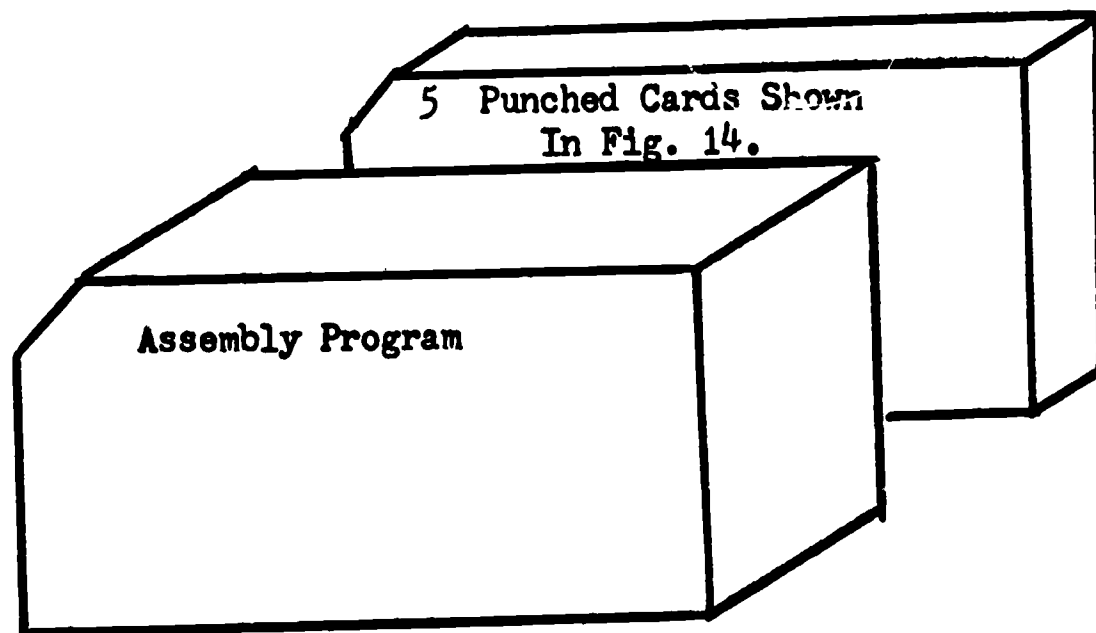

Figure 15. Assembly Program Plus Coded Program

First, the Assembly Program (itself a machine language program) would be read into the computer and stored into memory. When the last card of the Assembly Program was read, the control of the computer would be transferred to the instructions of the Assembly Program. The Assembly Program would command the computer to read, via the card reader, the first card of the coded program. When the Assembly Program was written, the designers of the Assembly Program set down certain rules as to where information will appear on the cards. Referring to Figure 14, the first three columns will contain the card number, columns 15 through 30 will contain the "Command," etc. So, everything has its proper place.

When the Assembly Program reads the first card of the coded program, the Assembly Program would translate this card into say four machine language words and store them in memory. Then the Assembly Program would read the second card and translate that

card into six machine language words, etc. until it read the "DATA" card. Then, the Assembly Program would transfer control of the computer to the translated coded program. Or, in other words, the coded program has now been translated into machine language words and is now in control of the computer.

The reader is probably saying to himself, "This is all very nice, but what is going on now that the coded program is in control of the computer?" To answer this, refer back to Figure 14, the first card of the coded program. This card says, "Read a card, via the card reader, into the card area and call that area X." The card reader would read the first data (not shown) card and the information would be stored in memory. The second card of the coded program says, "Read another card into the card area plus one card area and call that area Y." The card reader would then read the second data card and the information would be stored in memory. The third card of the coded program says, "Subtract X from Y." This would be accomplished by the computer's control unit. The fourth card says, "Store the result in X." The fifth card says, "Stop translation and release control to the program just translated." Remember, the computer's "vision" is limited to one statement (one card equals a statement), and it will execute statements in a sequential manner unless instructed by a statement to do otherwise.

This is just a brief introduction to machine language and the concept of translating human language into machine language by using a separate machine language program (Assembly Program) and the computer to do the translating. This latter concept was found to be extremely helpful to professional programmers in that it simplified their jobs. It also paved the way for a more powerful translating device which is called a "compiler."

Just as there are many types of versions of Assembly Programs available, there are many types of compilers available. However, there are only two compilers which are popular. They are COBOL and FORTRAN. But, before embarking on a discussion of these two compilers, a justification for their existence should be given. Compilers were designed with two objectives in mind; standardization of programming language, and simplicity to the user who may or may not be a programmer. Unfortunately, the scientific users couldn't agree with the business users as to what the common language should be. This was due to the fact that the scientific application and everyday language of the scientist differed from the businessmen. To resolve the problem, two different compilers were designed. COBOL was designed for business applications, and FORTRAN was designed for the scientific application. Both compilers were designed so that anyone who could

read, write, and add two numbers together could solve a problem on the computer. So, the compilers language had to come very close to the human language.

Only one compiler language will be covered here. That language will be FORTRAN, or FORmula TRANslation.

b. FORTRAN

(1) Description of FORTRAN. FORTRAN translates human formulas into machine language. And, the compiler itself is a machine language program. Probably, the reader is not "troubled" by the translating; but, the reader may have some reservations about the formula part, especially if the reader is not science oriented. Well, don't be. It is not as bad as it sounds. Can you understand

$$I = 1 + 1 \quad ? \quad (1)$$

Equation (1) is a valid FORTRAN statement and can be called a "formula." Programming in FORTRAN is almost as simple as equation (1). Now, all you have to do is learn a little programming terminology and a few rules. Then, you should be able to solve a problem on a computer. However, it must be remembered that this is an introduction to programming.

(2) Programming in FORTRAN on the IBM 1620. (a) Source Program. A "source program" is what you will be writing or "coding". It is a set of FORTRAN statements arranged in a logical order which the compiler will translate into machine language. Some compilers will punch out a machine language deck or "object deck" which contains machine language words generated during the translation of your source deck. To see an "object deck" is rather rare. This was done by early FORTRAN compilers that were being used on computers which had severe memory limitations.

(b) Logic. Many times, you will hear persons familiar with programming refer to the "logic" or "logic structure". What they are talking about is arrangement of statements in order to achieve a given objective. It is the process which the programmer uses to get a desired result. Because no two people have identical logical thought, no two programs will be the same if they are written by two separate people, even though the programs give identical results.

(c) Statements. You have heard the word "statement" used several times so far. Clarification of this term will be given now. A "FORTRAN statement" is equivalent to one punched card. Remember, in the discussion of the Assembly Program, every-

number every card (sequence the deck) of the program in case the program deck is dropped, the program deck can be sorted back into logical order.

The previous paragraph defined the format of a FORTRAN statement card. We have yet to define what a FORTRAN statement is. The form of the FORTRAN statements will be listed here for the readers convenience and explained later.

1. Arithmetic Statements.

A = B

Always characterized by an equal sign.

2. Control Statements.

GØ TØ n

IF (a) n₁, n₂, n₃

STØP

DØ n i = k₁, k₂

CØNTINJE

STØP

END

3. Input/Output Statements.

READ n, list

PUNCH n, list

PRINT n, list

4. Specification Statements.

DIMENSION v, v, v, ...

FØRMAT (s₁, ... s_n)

(d) Statement Numbers. Although statement numbers have been mentioned previously, they deserve further clarification because of their importance. Remember, statement numbers may appear in columns 2 through 5 on the statement card. However, you must be careful about the columns in which you put the numbers. For example, suppose you wished to reference statement 11. And, suppose

you punched a 1 in column 3 and a 1 in column 4 (See Fig. 17).

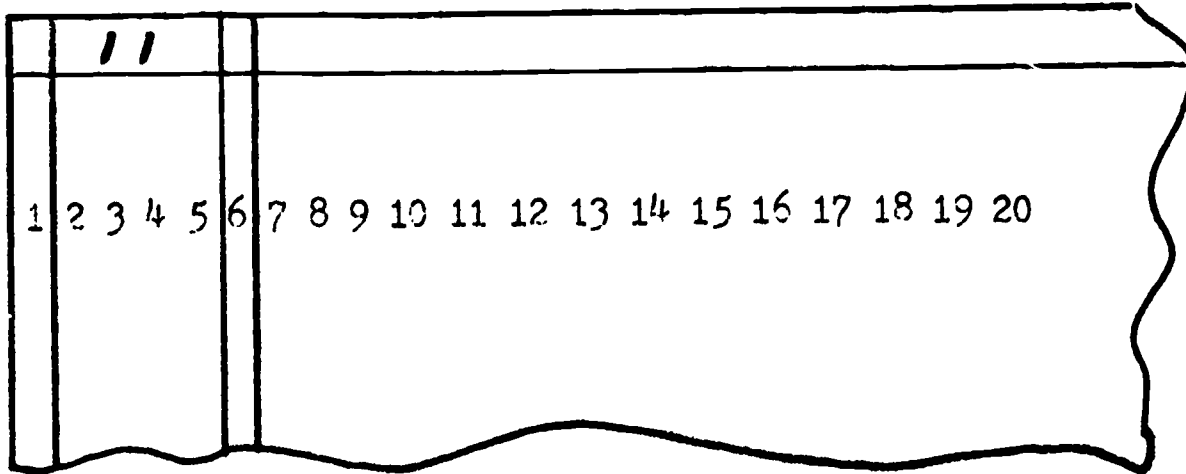

Figure 17. Illustration of Statement Number

Of course, this is an 11 to you; but, to the computer, it is 110. The blank in column 5 will be read as a zero (at least most computers will read it as a zero). The best policy is always work to the far right. This is called "working to the far right of the field." The "field" or "field width" to the compiler is 4 positions on the card starting in column 2 and ending with column 5. Now, you could put a statement number on every statement; but, this is not recommended for several reasons. One reason is that the human being doesn't like to do unnecessary work (most human beings). This is also true with the computer. So, the people who wrote the compiler took the problem of excessive statement numbers into account because they use up unnecessary memory locations which will only hurt you. Should you try this, the compiler will send a message back to you called a "diagnostic." This message might read, "THE FOLLOWING STATEMENT NUMBERS ARE NEVER REFERENCED BY THE PROGRAM. PLEASE ELIMINATE." Now, of course, the type of diagnostic that you get back, if you get one, will depend on who has written the compiler and how large the computer is that you are working on. Some of the diagnostic can become downright nasty. So, remember that statement numbers may appear anywhere in the program and are used as cross references. Don't use anymore than are necessary.

(e) Constants, Variables, and Subscripts. 1.

Constants. There are two types of constants which are permitted; fixed point (limited to integers), and floating-point (decimal point numbers). Perhaps you are not familiar with the term "integer." The following should clarify the term "integers:"

10)	10.11)
121) integers	121.4) floating point
3)	3.576)

Remember, an integer does not have a decimal point; floating point numbers do have a decimal point.

Now, there are two different types of floating point numbers. There is the regular floating point number and the exponential equivalent of the floating point number. It is just two different ways of representing the same number. The following should clarify the difference:

Floating Point Numbers
To The Human

+3.1415
+41.6
-41.6
-0.675
+5678.3

Exponential
To The Human

+3.1415X10⁰
+4.16X10¹
-4.16X10¹
-6.75X10⁻¹
+5.6783X10³

Floating Point Numbers
To The Computer

+3.1415+E00
+4.16+E01
-4.16+E01
-6.75-E01
+5.6783+E03

Exponential
To The Computer

+3.1415+E00
+4.16+E01
-4.16+E01
-6.75-E01
+5.6783+E03

Several points should be obvious to the reader. You will notice that the computer always handles floating point numbers in the exponential form. The human being finds this difficult; so, the compiler will do the translating for him. Notice also, that 10⁻¹ cannot be handled by the computer because the superscript (exponent), -1 does not exist for the computer. So the designers of the compiler represent 10 as an E and the + sign of the exponent goes before the E and the magnitude of the exponent follows the E.

2. Variables. The word "variable" usually means something that is subject to change. That is exactly what "variable" means in FORTRAN. Some variables may take on several numerical values.

There are two types of variables. There is one type for fixed point (integer) numbers and one for floating point numbers. When the compiler "sees", I,J,K,L,M, or N, it "knows" that this variable will be assigned an integer number. When the compiler "sees" any other letter of the alphabet with the exception of H (H is a very special letter which will be discussed under FORMATS), the computer "knows" that this variable will be assigned a float-

ing point number.

A variable may consist of 1 to 5 (some compilers will handle 6) characters (alphabetic or numeric). But, the first character must be an alphabetic character. The following should clarify the point:

<u>Fixed Point Variables</u>	<u>Floating Point Variables</u>
I	T
I1	T2
K12	TIME
MON1	ALPHA
MONDY	ALPH1

The following are not permitted:

<u>Example</u>	<u>Reason</u>
M=14	= is a special character
HIGH	First letter is an H
TI.2	. is a special character

3. Subscripts and Subscripted Variables.

Suppose you had a FORTRAN formula (equation or statement) as shown in Figure 18. If the program executes this statement only once,

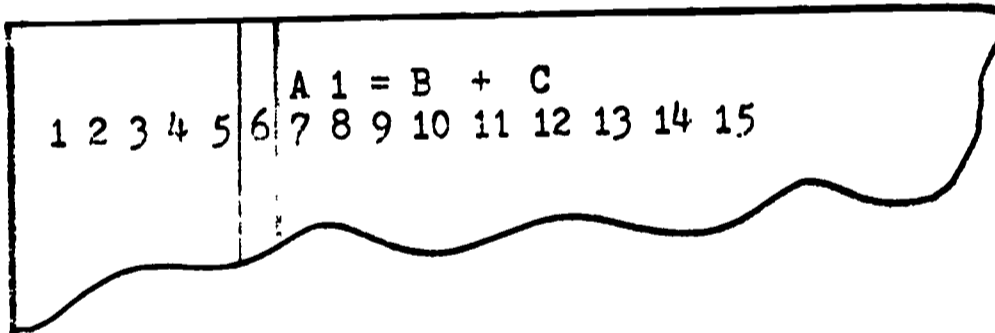

Figure 18. FORTRAN Arithmetic Statement

there is no problem. But, if you had several values for B and C, you would have to write several statements to make sure that they were stored properly. For example, you might write a series of statements as shown in Figure 19. There is nothing wrong with this; but, there is an easier way.

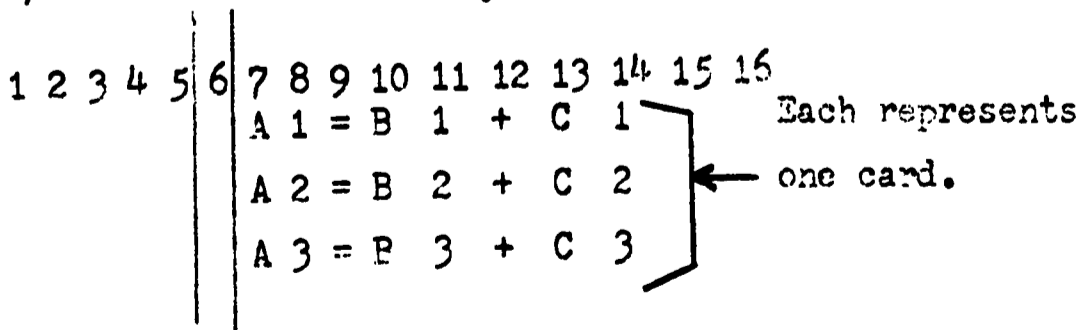

Figure 19. FORTRAN Statements

an arithmetic statement consisting of constants, variables, and functions which are separated by parenthesis and/or arithmetic operational symbols (+, -, /, *, **).

Suppose we wished to form the FORTRAN expression for

$$X = \frac{a + b + c}{d} + Y * Z \quad (2)$$

which would be

$$X = ((A + B + C)/D) + Y * Z \quad (3)$$

The compiler would "look" at this expression and compute $A + B + C$ and then divide that result by D . Then it would form the product of $Y * Z$ and add it to the result of $(A + B + C)/D$ and store the entire result in a memory location assigned to X .

There is a hierarchy of operations. The computer will do the most difficult things first. This hierarchy is listed in descending priority:

priority 1	**	meaning power notation, or $X ** 2$ which is equivalent to $(X)^2$
priority 2	and /	meaning division
	*	meaning multiplication
priority 3	and -	meaning subtraction
	+	meaning addition

Parenthesis are used to clarify the operation. The computer will always work from the inner most parenthesis outward. For example, suppose we wished to do this series of multiplication $A * B * C * D * E$. This would be taken to mean $((((A * B) * C) * D) * E)$. As another example, let us return to equation 3. Suppose we had written equation 3 like this:

$$X = A + B + C/D + Y * Z \quad (4)$$

Equation 4 would have been interpreted to mean

$$X = a + b + \frac{c}{d} + Y * Z \quad \text{or} \quad (5)$$

$$X = A + B + (C/D) + Y * Z \quad (6)$$

Equation 6 would not yield the same numerical result as equation 3

because of the hierarchy of operations. Parenthesis will alter the hierarchy of operations.

3. Arithmetic Formulas. Arithmetic formulas are characterized by an = sign. Several examples of arithmetic formulas have already been given. Equation 6 is an example. However, a few things have not been covered. Suppose we wrote

$$I = A * B + 4.6 \quad (7)$$

Equation 7 is a valid equation; but, it illustrates an interesting feature. Suppose the value of A was 2.0 and the value of B was 6.0. The result of the operation would be 16.6 which is a floating point number. But the result of the operation has been set equal to a fixed point number. The computer will perform the arithmetic operations in floating point; but, the computer would drop the decimal point and all numbers following the decimal point. This is called "truncation". The value of I stored in the computer would be 16, which is a fixed point number.

Now, suppose we wrote

$$I = K * B + 4.6 \quad (8)$$

This is not valid. You are trying to multiply a fixed point, K, number by a floating number, B. You would get a diagnostic saying, "MIXED MODE".

Now, suppose we wrote

$$I = B * 4 \quad (9)$$

Equation 9 is not valid because you are trying to multiply B, a floating point number, by 4, which is a fixed point number. The number 4 does not have a decimal point and is taken to be an integer. This is also a mixed mode. Remember, the computer can't "think". You have to do the thinking and give the computer direction.

(g) Control Statements. 1. Unconditional GØ TØ.
The general form of this unconditional branch statement is:

$$GØ TØ n \quad (10)$$

where n is a statement number. This is one of the statements used to cross reference other statements in the program as was mentioned earlier. When the computer reaches this statement in your program, the computer will unconditionally go to the statement that has the

corresponding statement number as established in the $G\emptyset T\emptyset n$ statement. For example,

$$G\emptyset T\emptyset 33 \quad (11)$$

The computer then transfers control to statement 33, wherever it might be in the program, and would then execute statement 33.

2. Computed $G\emptyset T\emptyset$. The general form of this version of an unconditional $G\emptyset T\emptyset$ is:

$$G\emptyset T\emptyset (n_1, n_2, n_3, n_4, \dots, n_{V_i}) V_i \quad (12)$$

where n_1, n_2, n_3, n_4 , etc. are statement numbers of branch points, and V_i is a non-subscripted fixed point variable. This statement is interpreted to mean "Go to one of the following statement numbers which are located in positions 1, 2, 3, 4, etc., depending on the value of the integer variable, V_i , at the time of execution." For example,

$$G\emptyset T\emptyset (5, 75, 100, 12, 16), I \quad (13)$$

Now, the value of the integer variable, I , would be computed at some time prior to the execution of the statement illustrated in equation 13. If the current value of I was 3, the computer would transfer control to the third statement 100. If the value of I was 5 when the statement illustrated in equation 13 was executed, the computer would transfer control to statement 16. If the value of I was negative, zero, or a positive integer of 6 or greater, the computer would stop because it doesn't know what to do. Zero and negative numbers are not permitted in this type of statement, and there are no statement numbers referenced in positions beyond the 5 position. This type of error is encountered upon execution of the program. You would not receive a diagnostic. The compiler can't help you here; it has finished translating and you are in command of the computer through your program.

3. IF Statement. The general form of the IF statement is

$$IF (a) n_1, n_2, n_3 \quad (14)$$

where (a) is any expression and n_1, n_2, n_3 , are statement numbers. This is an extremely useful statement. It is interpreted to mean "If the expression, a , is negative, go to statement n_1 ; if the expression, a , is zero, go to statement n_2 ; if the expression, a ,

is positive, go to statement n_3 ." Example:

$$\text{IF } (A * B/C) \text{ 12, 100 14} \quad (15)$$

The computer would first multiply A times B and divide the result by C to form the final result. The computer would then "look" at the numerical result and determine if it was negative, zero, or positive. If the result was negative, the computer would transfer control to statement 12. If the result was zero, the computer would transfer control to statement 100. If the result was positive, the computer would transfer control to statement 14.

4. DØ Statements. There are two forms of DØ statements. Let us treat them separately and take the simpler form first. The general form of the simplest DØ statement is:

$$\text{DØ } n \text{ } i = k_1, k_2 \quad (16)$$

This statement is interpreted to mean "Do statement n, and execute all statements between this Do statement up to and including statement n, which is called the "range of the Do loop." Before starting this operation, take the non-subscripted integer variable, i, and set it equal to k_1 . Now begin execution. Should the non-subscripted integer variable, i, be encountered in any statement within the operating range of this DØ loop, set, i in that statement equal to the current value of i for the DØ loop. When statement n is reached, execute statement n, and increment the value of i by one (1), or $i+1$. If the value of $i+1$ is less than or equal to k_2 , return to the controlling DØ statement and execute the first statement following the controlling DØ statement. Should the value of $i+1$ be greater than the value of k_2 , leave the range of the DO loop and execute the first statement after statement n." For example,

$$\text{DØ } 20 \text{ } I = 1, 30 \quad (17)$$

The computer would first set the integer variable, I, equal to 1 and execute all statements between the controlling DØ statement and statement 20, setting the value of I equal to 1 wherever it was encountered. When statement 20 was reached and executed, the value of I would be changed to 2, which is less than 30, and the process repeated. How many times would statement 20 be executed? Statement 20 would be executed 30 times.

The second form of the Do statement is just an extension of the first form. Its general form is:

$$\text{DØ } n \text{ } i = k_1, k_2, k_3 \quad (18)$$

This is almost identical to equation 16 except for k_3 . In the previous example, the value of i was incremented by one (1), or $i+1$. In this case, the value of i is incremented by k_3 . That is the only difference. The following list of $D\emptyset$ statements are given as examples. See if you can determine what will happen in each case. The examples are:

$$D\emptyset \ 3 \ K = 1, 4 \quad (19)$$

$$D\emptyset \ 17 \ \text{MOON} = 17, 84 \quad (20)$$

$$D\emptyset \ 10 \ \text{IHL} = \text{IH2}, 100, 2 \quad (21)$$

$$D\emptyset \ 12 \ \text{MM} = \text{MMM}, \text{MML}, \text{N} \quad (22)$$

Now, there is no reason why you cannot have $D\emptyset$ loops controlling other $D\emptyset$ loops, which is called "nesting". This can be illustrated graphically as shown in Figure 21. Now, if you had a set

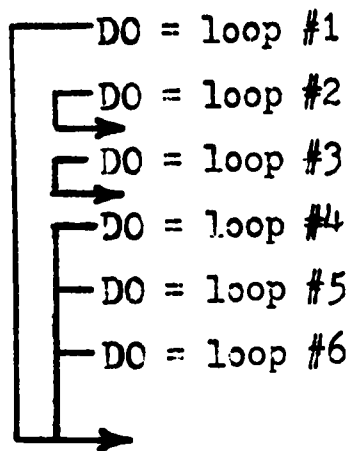

Figure 21. Nesting

of nested $D\emptyset$ loops as shown, you would in all probability be doing some very serious programming. But, it is not as bad as it looks. $D\emptyset$ loop #1 would be set, which is the master loop. $D\emptyset$ loop #2 would be set and executed until its values were exhausted. This would also be true with $D\emptyset$ loop #3. Now, we have something different happening. $D\emptyset$ loop #4 would be set. $D\emptyset$ loop #5 would be set. $D\emptyset$ loop #6 would be set and executed until exhausted. Then $D\emptyset$ loop #5 would be incremented and $D\emptyset$ loop #6 set and executed until exhausted. Then, $D\emptyset$ loop #5 would be incremented and the process repeated until $D\emptyset$ loop #5 was exhausted. Then $D\emptyset$ loop #4 would be incremented; $D\emptyset$ loop #5 would be set; $D\emptyset$ loop #6 set and executed until exhausted. The reader can see that things can rapidly become quite involved. $D\emptyset$ loop #1 has not even been incremented yet. But, if the reader is careful, he shouldn't have too much trouble following what is going on in Figure 21. Give it a try.

One thing to remember is that you can never break into the middle of a DO loop; but, you may break out of a DO loop before it is exhausted. This is illustrated in Figure 22.

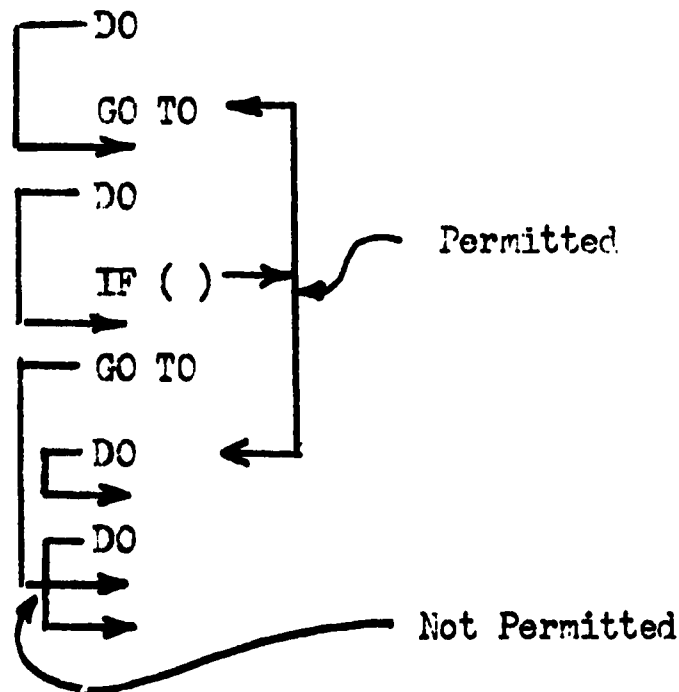

Figure 22. Diagram of Permitted and Not Permitted Branches or Operations

5. CONTINUE. This statement is the simplest one of all. The general form is:

CONTINUE (23)

It is interpreted to mean "Continue on with whatever you are doing." It is a "dummy statement" in that there is no operation performed. This statement is used whenever there is a possibility of confusion. This statement is most often used as the referenced statement of DO loops. For example:

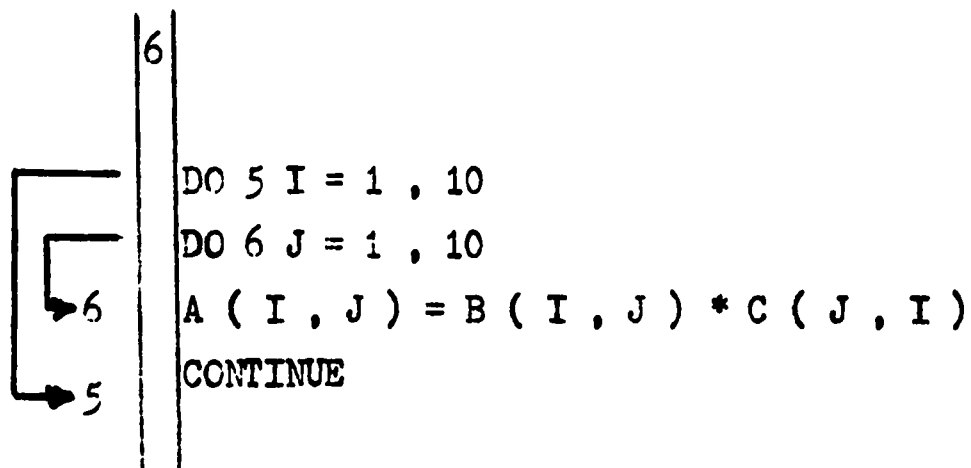

Figure 23. Example of CONTINUE Statement

This not only illustrates the use of the CONTINUE statement; but, also the use of subscripted variables controlled by DO loops. It also illustrates the use of two-dimensional subscripted variables, which will be covered when the DIMENSION statement is explained.

6. STOP Statement. The general form of this statement is:

$$\text{STOP} \quad (24)$$

This statement is interpreted to mean "Stop all calculation, program completed." This will be the last executable statement in the program. This statement halts the computer. It tells the computer that it is finished with the program.

7. END Statement. The general form of this statement is:

$$\text{END} \quad (25)$$

This must be the very last statement of the program. The END statement tells the compiler to stop translation and transfer control to the program.

(h) Specification Statements. These statements specify the upper and lower limits of subscripted variables and specify the format of input/output values of the data.

1. FORMAT Specification. In an earlier discussion, the word "format" was discussed. To define this term, the typewritten letter was used as an example. This example helped to explain the format of the FORTRAN statement and how it would appear on the standard Hollerith card (IBM card). The general form of the FORMAT statement is:

$$n \text{ FORMAT } (s_1, \dots, s_n) \quad (26)$$

where s_1, \dots, s_n are format specifications as described below, and n is a statement number. An example would be:

$$14 \quad | \quad \text{FORMAT} (13, F10.5, E12.5) \quad (27)$$

FORMAT statements are used to input or output data and may appear any where in the program. Remember that your primary input/output medium is the punched card. So, you are immediately limited to 80 columns, or 80 characters. The field width of the card is 80 positions.

There are three types of numerical field specifications. Or,

there is one field specification for each type of numerical value that has been covered. They are shown in Figure 24, and the examples are shown in Figure 26.

<u>Type</u>	<u>General Form</u>	<u>Remarks</u>
I (Integer)	I w	Used with integer numbers where w is the field width of the number.
F (Floating Point)	Fw.d	Used with floating point numbers where w is the field width and d is the number of decimal positions of accuracy.
E (Exponential)	Ew.d	Used with floating point numbers in the exponential form, where w is the field width and d is the number of decimal positions of accuracy.

FIGURE 24. Field Formats

<u>Number</u>	<u>Format Specification</u>	<u>Remarks</u>
b+40.5	F6.1	The b indicates a blank. The width, w, is 6 and 1 decimal position of accuracy is indicated. In determining w, count the number of digits in the number including blanks and add 1 for the decimal point and 1 for the sign of the number. Therefore, $w = 1$ (for decimal point) + 1 (for sign) + number of digits.
+0.74115-E04	E12.5	w is never equal to or less than 7. You must leave room for the sign of the number, the decimal point, the sign of the exponent, the letter E, and two positions for the power of the exponent. Therefore, $w = d + 7$.
+25	I3	w is the number of digits plus one for the sign of the number.

FIGURE 26. Examples of formats

Suppose that you wanted to input/output numbers so that it would appear as shown in Figure 27. The FØRMAT specification

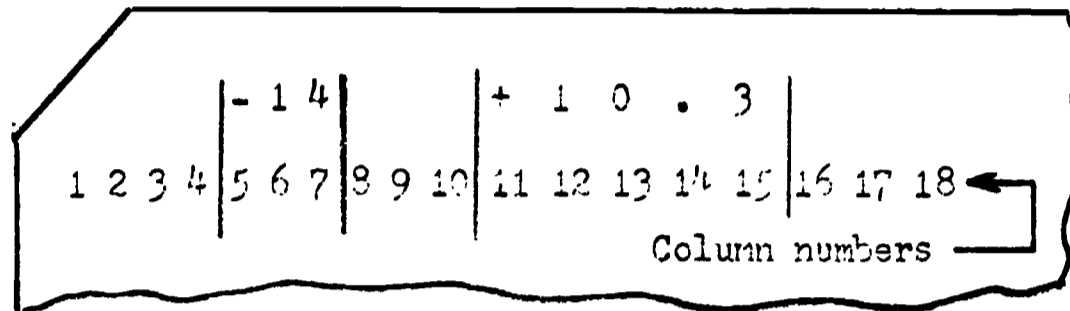

Figure 27. Data Card

would be as shown:

```
1 9  FØRMAT (4X, I3, 3X, F5.1)      (27)
```

Note that there is always a statement number associated with the FØRMAT statement. Also, the 4X means "skip 4 columns".

There is one more type of FØRMAT statement that has not been mentioned as yet. Suppose that you wanted to output the following sentence:

The value of X is 14.4

This is accomplished by the following FØRMAT statement:

```
1 4  FØRMAT (19HbTHEbVALUEbOFbXbISb, F5.1)      (28)
```

Note that there are 19 spaces between the H and the comma, where b indicates a blank space and is not punched on the card. This is the reason why the letter "H" is never used except in this case. It is named after Mr. Hollerith who invented the punched card for data processing and is called a "Hollerith field".

2. DIMENSION Specification. If you took a measuring stick which has been marked off with a small mark that is related to some "universal" standard, you may take that measuring stick and use it to measure the dimension of an object. Suppose that this measuring stick is a meter stick (39.37 inches or 3.28 ft.). Now, if the measurement of an object is given to be 10 centimeters (there are 100 centimeters to the meter), which is 3.937

inches or about 4 inches. What has happened is that one dimension of the object has been measured. If a second measurement of another side of the object is taken and is given to be 10 centimeters, two dimensions of the object is known. If a third measurement is taken of another side of the object and is given to be 10 centimeters, the third dimension has been measured. With no other information given, it would be logical to assume that the object is a cube.

The increment of measurement to a computer is the word. If the subscripted variable is written as $A(3)$, it would be safe to assume that the object is called A, A is 3 units long, and A has one dimension. Now, suppose the subscripted variable is written $A(3,3)$. The object is still called A, A is 3 units long and 3 units wide, and A has two dimensions. If the subscripted variable is written $A(3,3,3)$, the object is still called A, A is 3 units long by 3 units wide by 3 units in depth, and A has three dimensions. This is the purpose of the DIMENSION statement. That is, to define the size of the subscripted variable to the computer so that it knows how many words to allocate for the subscripted variable. The general form of this statement is:

$$\text{DIMENSION } v_1, v_2, v_3, v_4, \dots \quad (29)$$

where v is a subscripted variable. For example,

$$\text{DIMENSION } A(3,3), B(4), CC1(3,4) \quad (30)$$

When the compiler "sees" "equation" 30, it will allocate 9 words and call it A, 4 words and call it B, 12 words and call it CC1. This can be seen in Figure 28. The standard convention is: the first number indicates the row, the second number indicates the column, and the third number indicates the plane.

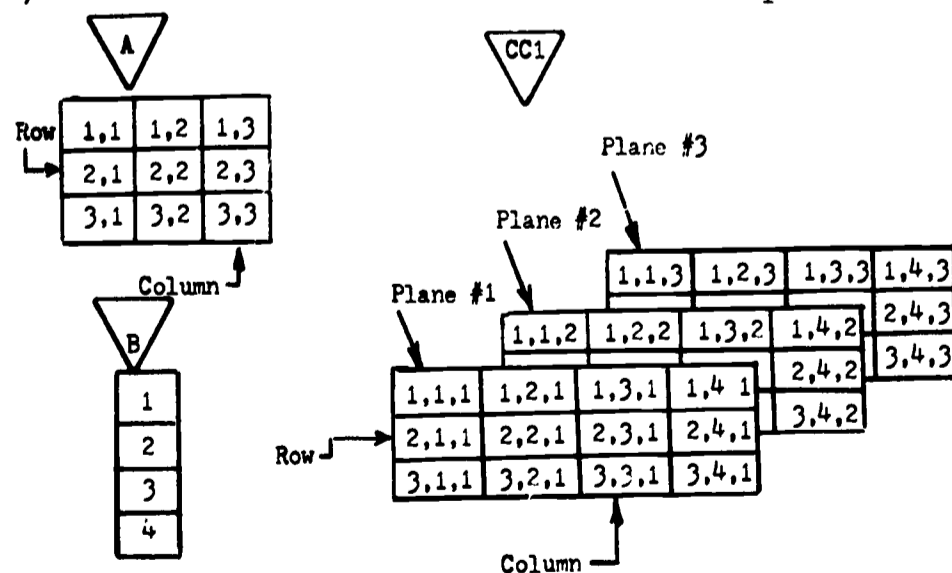

Figure 28. Visual Model of Subscripted Variable Memory Assignment.

The DIMENSION statement must describe all subscripted variables used in the program before the subscripted variable is used. A good policy is to make the DIMENSION statement the very first statement of the program. Figure 29 will serve to correlate some of the concepts presented so far.

```

        6 |
        | DIMENSION A(3,3), C(3,3)
        | .
        | .
        | DO 10 I = 1,3
        | DO 11 J = 1,3
11     | C(I,J) = A(I,J) * B(J,I)
10     | CONTINUE
        | .
        | .
    
```

Figure 29. Use of the DIMENSION , DO , and CONTINUE Statements

The first time through the loops, statement 11 would "appear" to be:

$$11 \left| \begin{array}{c} 6 \\ \hline \end{array} \right| C(1,1) = A(1,1) * B(1,1) \quad (31)$$

The next time through,

$$11 \left| \begin{array}{c} 6 \\ \hline \end{array} \right| C(1,2) = A(1,2) * B(2,1) \quad (32)$$

The next time through,

$$11 \left| \begin{array}{c} 6 \\ \hline \end{array} \right| C(1,3) = A(1,3) * B(3,1) \quad (33)$$

The next time through,

$$11 \left| \begin{array}{c} 6 \\ \hline \end{array} \right| C(2,1) = A(2,1) * B(1,2) \quad (34)$$

The next time through,

$$11 \left| \begin{array}{c} 6 \\ \hline \end{array} \right. C(2,2) = A(2,2) * B(2,2) \quad (35)$$

and so forth until the master loop is exhausted.

(i) Input/Output Statements. 1. READ Statement.

The general form is:

$$\text{READ } n, \text{ list} \quad (36)$$

where n is the FØRMAT statement number, and then a list of the variables. When the computer executes this statement, it will read a card through the card reader. An example would be Figure 30.

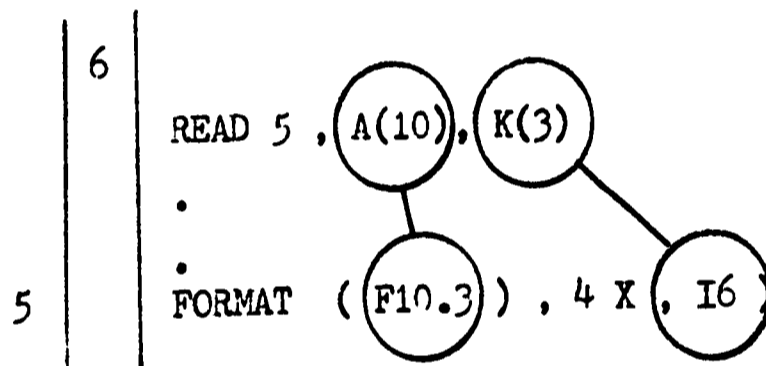

Figure 30. READ and FORMAT Statements

The data card that would be read by the card reader would look like the card shown in Figure 31.

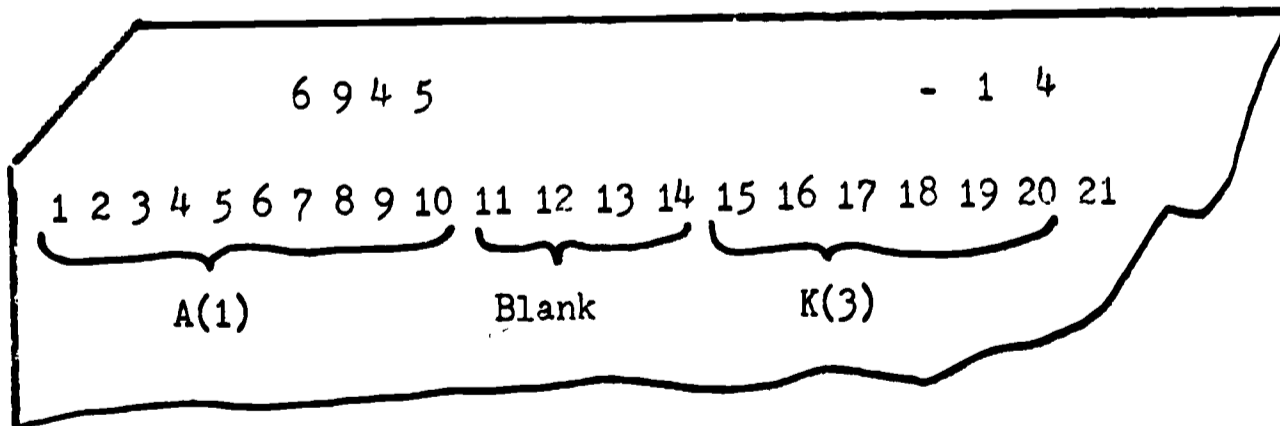

Figure 31. Data Card

Note that there is no decimal point punched on the card. The computer will automatically take the decimal point to be between columns 7 and 8. So the number stored in memory location A(1) is 6.945. If a decimal point was punched on the data card and the decimal point location did not agree with the field specification, the decimal point punched on the card would override the field specification. For example, suppose a decimal point was punched in Column 5. The number stored in A(1) would be 0.06945. Note also, that the sign was not punched. Unless otherwise indicated (that is, a negative sign punched on the data card), the computer will take the number to be positive. Of course, the value stored in K(3), would be -14, which is an integer number as specified.

2. PUNCH Statement. The general form of this statement is:

PUNCH n, list (37)

where n is the FORMAT statement number, and then a list of the variables. This statement is identical to the READ statement except that the computer will punch a card instead of reading a card.

3. PRINT Statement. The general form of this statement is:

PRINT n, list (38)

where n is the FORMAT statement number, and then a list of the variables. This statement is identical to the READ and PUNCH statements except that the computer will output on a high speed printing device. If the computer being used does not have a high speed printer, do not use the PRINT statement.

c. Examples of Programs. All that remains for the reader to do is to go through the following programs slowly. Go through the examples just as the computer would do, one statement at a time. Do exactly what the statement says to do and take the next statement in sequence. If you hit a branch statement, branch to that point and execute that statement and take the next statement in sequence. Do not return to the point where the branch originated.

The rest is up to you. All you need now is a little practice.

1. PROBLEM:

Assume census data for 300 students. One piece of data, KORS, is coded for the courses completed. There are 99 courses available, one is Art coded 63. For the 300 students, this is a program to determine the number who have taken Art. Three hundred data cards are available, and are similar to the example shown below. Read the program shown here and determine step by step what will be accomplished.

```
C      |
      |
      | 1      | DETERMINING NUMBER OF STUDENTS WHO HAVE
      |         | TAKEN ART COURSES.
      |         |
      |         | FØRMAT (F 3.2, 2I6, 2F10.3, 2I3)
      |         | DØ 10 I = 1,300
      |         | READ 1, A, J, KØRS, GPA, B, MAX, MIN
      |         | K = 0
      |         | IF (KØRS - 63) 10, 3, 10
      | 3      | K = K + 1.
      | 10     | CØNTINUE
      |         | PUNCH 2, KORS
      | 2      | FØRMAT (I3)
      |         | STØP
      |         | END
```

19 31 46 19 3 161 371 (Sample
Data Card -
300 Cards)

2. PROBLEM:

This next problem will be called a Supply List Calculation. After going over each command carefully see if you can give an accurate description of the output.

```
C          SUPPLY LIST CALCULATION
1          FORMAT(14F5.2)
          READ1,S1,S2,S3,S4,S5,S6,S7,S8,S9,S10,S11,S12,S13,S14
          T=S1+S2+S3+S4+S5+S6+S7+S8+S9+S10+S11+S13+S14
          PUNCH4,T
4          FORMAT(F7.2)
          TOTAL=T/4.
          PUNCH4,TOTAL
          X=TOTAL*3.
          PUNCH4,X
          STOP
          END
```

2.57 11.34 8.77 4.33 5.13 7.37 6.12 6.99 2.53 15.45 2.15 13.00 5.76 1.08
(Sample Data Card)

3. PROBLEM:

Try this third problem, this time design your own data cards and check what the output should be.

C SOLUTION FOR GAS MILEAGE

```

    DIMENSION GAL(100),OD(100)
    TOTAL=0.0
    N=1
    READ 10,GAL(N),OD(N),K
10  FORMAT(F4.1,F7.1,68X,I1)
    N=N+1
    IF(K)40,40,41
41  N=N-1
    DO 100 I=2,N
100 TOTAL=TOTAL+GAL(I)
    ODB=OD(N)-OD(1)
    TMG=ODB/TOTAL
    PUNCH 11, TMG
11  FORMAT(35HTHE TOTAL NUMBER OF MILES PER GAL=,F10.3)
    STOP
    END
```

4. PROBLEM:

For this last problem let's consider the familiar bank account for the average person. The program will result in a statement for the end of the month. The data will consist of a bank balance at the beginning of the month BBI. The checks - CC (I). The deposits + CC (I). The interest rate $\frac{1}{2}\%$ per month on the end of the month balance. Make up your own values for the beginning balance, the checks and the deposits. A blank card at the end of the program data will terminate the calculations. The program will accept up to 50 checks and deposits combined.

	BANK BALANCE CALCULATION
	READ 1, BBI
	DO 4 I = 1, 50
	READ 1, CC(I)
	IF(CC(I)) 4, 5, 4
	BBI = BBI + CC(I)
	IF(BBI) 7, 4, 4
4	CONTINUE
	GO TO 5
7	PRINT B, BBI, CC(I)
	GO TO 2
5	PRINT 3, BBI
	DDI = BBI * 0.005
	PRINT 9, DDI
	EEI = BBI + DDI
	PRINT 6, EEI
1	FORMAT (F10.2)
3	FORMAT (.15 H NEW BALANCE .15, F10.2)
8	FORMAT (.27 H OVER-DRAWN BALANCE TO DATE, F10.2, 11 H LAST CHECK, F10.2)
9	FORMAT (.24 H THE INTEREST THIS MONTH, F10.2)
6	FORMAT (.28 H BALANCE WITH INTEREST ADDED, F10.2)
2	STOP
	END

E. Examples of Computer Uses

1) Credit checking by computers.

Credit Data Corporation, Los Angeles, is in the process of expanding its credit information service to the entire State of California. Its customers are the thousands of banks, finance companies, retailers and other businesses which make consumer loans or sell on credit. According to William Cole (4), its data base is the derogatory, current and historical data about millions of individuals gathered from the files of the subscribing organizations and businesses. The system keeps the central file up-to-date by encoding all available credit application decisions and other new information, and then modifying the individual's tally. Equipment used is a central computer, disk files for storage, and a telephone communication network. Credit Data claims a 'one in 10,000' mismatch between an individual and his file.

2) Computer assisted instruction.

A series of programs published by IBM under the title of SPOT (Statistical Project Organizer for Teaching) can be used to design individual student statistical laboratory projects. Esther and Harold Highland (10) describe SPOT's operation. With the computer doing the calculating, the student's attention is on principles and concepts rather than on mere 'number pushing.' For example, the effect of changing the class interval size is a frequency distribution (Sturges' Rule) is instantly dramatized rather than belatedly noticed, if the numerical calculations are delegated to the computer.

3) Animation in movies by computer hardware.

A computer and an automatic microfilm recorder consisting of a camera and a cathode ray display cube, is used to make movies and record designs and diagrams. Illustrations in the article by Kenneth Knowlton (13), show among other designs, shots from an animated computer-produced movie explaining its own operation. Two programming languages, BEFLIX and L⁶, simplify the communication of design statements.

4) Training systems.

"People learn more by being right than by making mistakes." This educational truism is being applied to on-the-job training programs at business institutions (3). Harold Moon, Programmed Instruction Unit Manager at McGraw-Hill, notes that the programs teach 'doing the job' rather than 'how to talk about doing the job'. Results check out that Teaching Machine teaching is sig-

nificantly more effective and cheaper than more conventional on-the-job training when the training is appropriate for machine teaching. The Schering Corp. trained salesmen in the clinical and pharmacological background of the drug products they present to physicians. The E. I. Dupont de Nemours & Co. economized on teaching the reading of engineering drawings. Sandia Corp. used programs from TMI Grolier to teach both Russian and electronics at considerable savings. The control group taught by conventional methods in these three cases learned less at greater expense.

5) Computers that talk.

The message you hear may be a piece-meal thing, according to James Procter, "More and More Computers do the Talking" (19). The Air force currently is using a digital-to-voice system called AVLOW (Automatic Voice Link Operation Weather) to provide up-to-the-second reports to airplane pilots making landings. The American Stock Exchange uses Am-Quote, a computer system that reads ticker-tape, updates its data file, then provides read-out by display on a cathode-ray tube, by printouts, or by talk-outs from the electronically-controlled human voice film recording. The unit that does the talking is the Speechmaker, developed by Cognitronics Corp. The verbalizer uses a pre-recorded vocabulary of 64 individual message segments to construct any requested stock market quotation. What surprises one most is the parsimony of stock market language required: letters of the alphabet, numbers, up, down, open, close, high, low, a few others, and that does it.

6) The Bible business.

The annual Bible business of the American Bible Society, New York, is of the order of 75 million copies, sent to 150 countries, in 1250 languages and dialects, in Braille in 50 languages, and on recordings. "Computer-aided Bible Distribution" (5) describes how administrative detail, inventory control, and the complex logistical problems of speeding millions of Bibles to people all over the world is handled by an IBM 360 computer.

7) Computers and Art.

The "Annual Art Contest," held by Computers and Automation (1), illustrates some principles of model-building at their free-form best. Among the drawings submitted were: computer produced patterns; programmed variations on a theme originated by an artist; displays specified by mathematical relationships with origin points determined by random number generators. The single-color drawings

were all made on Plotters using computer output. First prize went to an 'art professor - programmer - computer - plotter' team for Sine Curve Man, 1967.

Gerald Strand, in "The Computer in Musical Composition" (20), writes of the two main aspects to computer experimentation in musical composition. One is the use of the computer to aid the composer in the production of a score. The other is the use of the computer to generate actual sounds. The sound of music is essentially cyclic repetitions of sound waves, which may range anywhere from say 20 cycles per second to say 15,000 cycles per second. In this second approach, a computer, the Bell Telephone Laboratory Music IV program, and the composer's mathematical description of the desired score is used to generate a deck of punched cards that represent the musical piece. This deck of cards is then processed through a digital-to-analog converter which produces equivalent varying voltages. These voltages are then applied to a tape recorder head, or directly to a speaker, thus producing sound.

A homier application of this second approach is a computer at Stanford Research Institute, which has a combination microphone amplifier tucked inside it. The computer operator recognizes the sound patterns made by standard programs, notices troubled computer runs, and also gets clues for planning ahead.

8) Computers and Soviet Olympic athletes.

Since 1958, the Soviet Union has embarked on an enthusiastic development of applications of cybernetics, with an emphasis on the use of automatic computers. One target of all this activity is a dynamic model of the entire Soviet economy, with systematic control of planning and administration of large enterprises, writes Brainard and Hitt (2). Another target of Soviet cybernetics is the Soviet athlete who benefits from a computer simulation of a sports event (23). The 'most useful muscles for the event' are pinpointed, and the Soviet athlete then concentrates on those particular muscles for development and training.

9) Computerized U.S. citizen?

Don Fabun, in The Dynamics of Change (9), takes an illustrated poetry-citing overview of Life-1967, U.S.A. Logical, rational, organized thinking and doing is indeed common, and does lend itself to automation using computers either as processor or investigator. "But we do not, as individual human beings, lead daily lives that are essentially rational or logical. We swim immersed in a world of highly personal, emotional, religious, and largely subconscious reactions."

Still, the 'rational' can be counted, and the 'emotional' can be tabulated. The Behemoth of statistical information gatherers is the U.S. Department of Labor, Bureau of Labor Statistics (21). A computer, magnetic tape, punched card, printer system manages the six files of the Bureau of Labor Statistics. The files are: Survey of Labor Turnover; National Survey of Scientific and Technical Personnel in Industry; Survey of Industry Employment Payroll and Hours; Survey of Industry Employment, Worker Earnings and Hours of Work for States and Areas; Estimates of Labor Force Characteristics from Current Population Survey; Survey of Consumer Expenditures. The total approximate number of punched cards or card images is 22,600,000.

When Elmo Roper went modern he brought with him a treasury of facts and figures about people. The Roper Public Opinion Research Center has a punched-card based computer system, and a data-base of 7,000 studies, and over 12,000,000 cards and card images (16). The Roper Center keeps up-to-date via sample surveys from 26 American data suppliers, and from 77 other organizations located in 43 countries abroad.

10) Computers in Education violate Copyright Laws?

An important development in computer design is the time-sharing system; that is, a computer system that interacts with many simultaneous users through a number of remote consoles. John McCarthy (14) writes that in 1962, time-sharing was an experimental program at MIT. In 1967, time-sharing is an increasingly common environment for university research, elementary school education, high-school counseling, and large-and-small-business uses. Of course, the larger the data base available, the more valuable the computer-use time can be. And so, EDUCOM (the Interuniversity Communication Council) grew, and a National Data Center was proposed, each with its hazards. The "Multi-access Forum," in Computers and Automation (18), has a protest by Anthony Oettinger to the Copyright Revision Bill S.597, which would seriously cripple EDUCOM; and David Warburton examines the proposed National Data Center for invasion of personal privacy.

11) Language translation.

Hopes for computerized translation of textual material from one language to another have come half circle from high enthusiasm in the late 1940's, to cautious reappraisal of the problems involved, in 1967. Warren Weaver, in his Science and Imagination (22), traces the changing attitudes about language translation feasibility. The prospect of computer translation presently awaits on further work at pinning down the ambiguities occurring

in some nouns, verbs, and adjectives, and a statistical description of the semantic character of languages.

12) The computer puts, finds, reminds.

The system approach, when used in a library that has ready access to a computer with an on-line (attached) printer, can result in a library where information about a book or periodical needs to be key-boarded only once. All the information units are tagged, and therefore selectively retrievable. Circulation cards and records, inventory, ordering and acquisitioning, special bibliographies, all are aided, abetted, or implemented by IBM ASDD's computer based library system (11), (12).

MEDLARS (Medical Literature Analysis and Retrieval System) is the result of cooperative efforts by the National Library of Medicine and the General Electric Company Information Systems Operation to develop and implement a computer based system for disseminating information about the contents of medical journals⁽¹⁵⁾. It is MEDLARS-in-action that has been responsible for Index Medicus since January 1964, for the Bibliography of Medical Reviews, and for locally produced demand-bibliographies. In practice, the National Library of Medicine produces the master magnetic tapes and sends copies to requesting installations. To prepare the tapes, each article that is to be indexed is identified by author, title, and journal name and date. The subject headings and descriptors are chosen from the controlled vocabulary in MESH (Medical Subject Headings), the dictionary to Index Medicus and its related publications. In addition to the usual (up to four) number of subject headings chosen to describe the article for Index Medicus, up to eight more descriptors are assigned to denote specific aspects of the article's content. When a doctor requests a search on specific topics from his local computer installation, the complete file of subject headings and descriptors is searched, then listed. The National Library of Medicine aims at comprehensive coverage. At present, about 2,000 journals and 152,000 articles are covered annually.

The article "Hospital Medical Information Systems" (8) gives a look into a new way of storing, organizing and retrieving hospital patient information. The requirements and possibilities of an information system in the medical field show that much of the information to be processed is either the source or the result of physicians' written and verbal orders for treating patients. The results of observations of patients and of tests and treatments, are constantly added to patients' records. When all these communications are stored in a computer with typewriter and cathode-ray display input and output options, then both the

doctor and the patient will surely be better served.

13) Freedom from tedium.

"Man is quite good at inventing and organizing ideas, making associations among apparently unrelated notions, recognizing patterns and stripping away irrelevant detail; he is creative, unpredictable, sometimes capricious, sensitive to human values. The computer is almost exactly what man is not. It is capable of paying undivided attention to unlimited detail; it is immune to distraction, precise and reliable. It suffers from neither boredom or fatigue. It needs to be told only once; thereafter it remembers perfectly until it is told to forget, whereupon it forgets instantly and absolutely" (7).

Many industrial processes require undivided attention to unlimited detail, and many such plants are already run by computers. Chemical plants and numerically-controlled machining tools are two activities where the number of variables and the complexity of their interaction is too mathematically long-winded for instant calculation by humans; but, for the computer, such calculations are possible, reliable, and instantly translated into appropriate action. (7)

Dow Badische Chemical Co. manufactures chemical intermediates which include caprolactam, acrylic monomers, and butanol (17). Their computerized communication network not only provides for assurance that the chemical reactions are all proceeding as desired, it also permits rapid evaluation of the effect of deliberate process changes. Perhaps of equal significance, messages can be sent from one station to another except when a station is on-line.

Lyman Printing and Finishing Co. has disclosed that its computer control system developed by Honeywell, Inc., and described as the first ever applied to a textile production process, has been in operation since February 1966 (6). The continuous color and chemical blending of synthetic fabrics, the automatic opening and closing of valves that sequences the filling, heating, cooling, pressurizing and emptying of becks (tanks) is under computer direction. For a bonus, the computer summarizes, on a teleprinter, what happened during the dyeing process. There is a manually operated back-up control system that can assume the computer's role temporarily in an emergency.

References

The following references are cited in the texts of part II and are identified by the appropriate number. A more generalized bibliography follows for the entire report.

1. "Annual Art Contest," Computers and Automation. XVI, August 1967. p. 8-21.
2. Brainard, Robert W., and Hitt, William D. "Cybernetics in the U. S. S. R.," Computers and Automation. XVI, April 1967. p. 10.
3. "A Businessman's Guide to Teaching Machines," Business Management. XXII, August 1962. p. 40-56.
4. Cole, William. "Credit Checking by Computer," Datamation. XII, October 1966. p. 33-4;39.
5. "Computer-aided Bible Distribution," Computers and Automation. XVI, February 1967. p. 45.
6. "Computer Masterminding Textile Dyeing Process," Computers and Automation. XV, November 1966. p. 37-38.
7. Coons, Steven Anson. "The Uses of Computers in Technology," Scientific American. CCXV, September 1966. p. 176-188.
8. Diebold Group, Inc. "Hospital Medical Information Systems," Automatic Data Processing Newsletter. XII, 1967. In Literature on Automation. VIII, January 1968. p. 49.
9. Fabun, Don. The Dynamics of Change. Englewood Cliffs, New Jersey: Prentice-Hall. 1967. p. 149.
10. Highland, Esther H., and Highland, Harlod J. "Teaching Statistics with a Computer," Business Automation, Automation Educator Edition. XIV, April 1967. p. 50AE-53AE.
11. IBM. ASDD Library Procedures Manual. Coorinated and Edited by Vilia Ma. Los Gatos, Calif.: IBM ASDD. 1967.
12. IBM. Mechanized Library Procedures for the IBM Advanced Systems Development Division. Report No. E20-0285-0. Los Gatos, Calif.: IBM. 1967.
13. Knowlton, Kenneth C. "Computer-generated Movies, Designs and Diagrams,," Design Quarterly 66/67. 1967. p. 59-63

14. McCarthy, John. "Time-Sharing Computer Systems," in Greenberger, Martin. Computers and the World of the Future. Cambridge, Mass.: The M. I. T. Press. 1962. p. 221-248.
15. The Medlars Story. Bethesda, Maryland: General Electric Co. Information Systems Operation. 1963. 74p.
16. Mendelsohn, Arthur, and Rosenthal, Howard. "The Roper Center Automated Archive," The Public Opinion Quarterly. XXXI, Spring 1967.
17. Miller, James. "Plant-wide Computer Capability," Decus Proceedings; Papers and Presentations of the Digital Equipment Computer Users Society, Fall Symposium, November 29, 1965. Stanford, Calif.: Stanford University. p. 81-83.
18. "Multi-access Forum," Computers and Automation. XVI, May 1967. p. 8-11.
19. Proctor, James W., Jr. "More and More Computers Do the Talking," Business Automation. XIII, December 1966. p. 36-39;42-43.
20. Strang, Gerald. "The Computer in Musical Composition," Computers and Automation. XV, August 1966. p. 16-17.
21. U. S. Department of Labor. Bureau of Labor Statistics. Major BLS Programs - A Summary of Their Characteristics. Washington, D. C.: Bureau of Labor Statistics. 1967.
22. Weaver, Warren. Science and Imagination. New York: Basic Books. 1967. 295p.
23. Yelewsky, Gerald. "Sports and Cybernetics," Soviet Life. November 1966.

SUMMARY

This report and the preceding one on the subject have been designed to assist other teachers in setting up an interdisciplinary course exploring the relationships between computerized technology and society. An attempt has been made to suggest various activities which can stimulate student interest in the topics discussed, and to provide resource materials which will allow the teacher to examine the subjects in more than casual fashion.

It is recommended that the two reports be considered complementary to each other.

BIBLIOGRAPHY

CYBERNATION AND TRANSPORTATION

- Aitken, J. M. "Simulation of Traffic Conditions at an Uncontrolled T-Junction," Traffic Engineering and Control. V, 1963. p. 354-358.
- Berry, D. S. and Salterly, G. T. "Systems Approaches in Transportation Planning," Proceedings of Institute of Traffic Engineers. 1964. p. 202-211.
- Bleyl, R. L. "Simulation of Traffic Flow to Compare Regular and Flashing Traffic Signal Operation," Proceedings of Institute of Traffic Engineers. 1964. P. 152-161.
- Brown, Robert S. Transport and the Economic Integration of South America. Washington: The Brookings Institution. 1966.
- Cleveland, Donald E., editor. Manual of Traffic Engineering Studies. 3rd Edition. Washington: Institute of Traffic Engineers. 1964.
- Creighton, R. L. "Perting a Transportation Study," Highway Research Board Record 38. 1964. p. 55-77.
- Davinroy, T. R.; Ridley, T. M.; Wootlow, H. J. "Predicting Future Travel," Traffic Engineering and Control. V, October 1963. p. 366-371.
- DeLeuw, Cather and Co. "The Effect of Regulatory Devices on Intersection Capacity and Operations," Final Report, Project 3-6. National Cooperative Highway Research Project. August 1966.
- Dockerty, A. "Accelerations of Queue Leaders from Stop Lines," Traffic Engineering and Control. VIII, 1966. p. 150-152.
- Gafarian, A. V. and Walsh, J. E. "Statistical Approach for Validating Simulation Models by Comparison with Operational Systems - Illustrated for Traffic Flow," SP-2367. Santa Monica, Calif.: System Development Corporation. 1966.
- Garrison, W. L. "Urban Transportation Planning Models in 1975," Journal of the American Institute of Planners. XXXI, 1965. p. 156-158.

- George, E. T., Jr. and Heroy, F. M., Jr. "Starting Response of Traffic at Signalized Intersections," Traffic Engineering. XXXVI, July 1966. p. 39-43.
- Gerlough, D. L. and Wagner, F. A. "Improved Criteria for Traffic Signals at Individual Intersections; Interim Report," National Cooperative Highway Research Program Report No. 3. Highway Research Board. 1964.
- Gerlough, D. L. and Capelle, D. G., editors. An Introduction to Traffic Flow Theory, Special Report 79. Highway Research Board. 1964.
- Gerlough, D. L. and Wagner, F. A. "Simulation of the Network," Proceedings of Highway Conference on the Future Of Research and Development in Traffic Surveillance, Simulation and Control, September 14-15, 1964. Washington, D. C.: Bureau of Public Roads. p. 152-165.
- Gottman, Jean. Megalopolis. Cambridge, Mass.: M. I. T. Press. 1967. 810p.
- Herman, Robert and Gardels, Keith. "Vehicular Traffic Flow," Scientific American. CCIX, December 1963. p. 35.
- Hersey, Irwin. "High Speed Ground Transportation: Technology and You, Part XIV," Engineering Opportunities. XIV, January 1968. p. 8.
- Highway Capacity Manual, 1965. Special Report 87. Highway Research Board, 1966.
- Kain, John F. "A Contribution to the Urban Transportation Debate: An Econometric Model of Urban Residential and Travel Behavior," Review of Economics and Statistics. February 1964. p. 55-64.
- Knell, J. H. "Analyzing Vehicular Delay at Intersections Through Simulation," Highway Research Board Bulletin 356, 1962. p. 28-39.
- . "Intersection Delay Obtained by Simulating Traffic on a Computer," Highway Research Record 15. Highway Research Board, 1963. p. 73-97.
- . "Results of Computer Simulation Studies as Related to Traffic Signal Operation," Proceedings of Institute of Traffic Engineers, 1963. p. 70-107.

- Kidd, E. A. and Laughery, K. R. "A Computer Model of Driving Behavior: The Highway Intersection Situation," Paper prepared for Presentation at the Highway Research Board, 44th Annual Meeting. Cornell Aeronautical Laboratory. January 1965.
- Lang, A. S. and Soberman, R. Urban Rail Transit: Its Economics and Technology. Cambridge, Mass.: M. I. T. Press. 139p.
- Lansing, J. B. and Barth, N. Residential Location and Urban Mobility: A Multivariate Analysis. Ann Arbor, Mich.: University of Michigan. 1964.
- Lewis, R. M. "A Proposed Headway Distribution for Traffic Stimulation Studies," Traffic Engineering. XXXIII, February 1963. p. 16-19, 48.
- "The Simulation of Traffic Flow to Obtain Volume Warrants for Intersection Control," Joint Highway Research Project, No.23. Lafayette, Indiana: Purdue University. 1962.
- Lewis, R. M. and Michael, H. L. "Simulation of Traffic Flow to obtain Volume Warrants for Intersection Control," Highway Research Record 15. Highway Research Board, 1963. p. 1-43.
- M. I. T. Students System Design Project. The Glideway System: A High Speed Ground Transportation System for the Northeast Corridor of the United States. Cambridge, Mass.: M. I. T. Press. 1967. 336p.
- M. I. T. Students System Project. Project Metran. Cambridge, Mass.: M. I. T. Press. 1967. 272p.
- Mahoney, Gene. "IBM-City of San Jose Traffic Control Project," Western I. T. E. (Institute of Traffic Engineers.) XIX, March/April 1965. p. 4.
- Manheim, M. L. Hierarchical Structures: A Model of Design and Planning Processes. Cambridge, Mass: M. I. T. Press. 1967. 227p.
- Martin, B. V.; Memmott, F. W.; Bone, A. S. "Predicting Future Demand for Urban Area Transportation," HBR Bulletin, 326, 1962. p. 69-97.

- Martin, B. V.; Memmott, F. W. III; Bone, A. J. Principles and Techniques of Predicting Future Demand for Urban Area Transportation. Cambridge, Mass.: M. I. T. Press. 1967. 224p.
- May, Adolf D. , Jr. "Gap Availability Studies," Highway Research Record 72. Highway Research Board, 1965. p. 101-136.
- Michaels, R. M. "Perceptual Factors in Car Following," Proceedings of the 2nd International Symposium on the Theory of Road Traffic Flow, London, 1963. Paris: Organization for Economic Cooperation and Development, 1965. p. 44-59.
- Myer, John R. "Transport Technologies for Developing Countries," American Economic Review. LVI, May 1966. p. 83.
- Meyer, J. R.; Kain, J. F.; Wohl, M. The Urban Transportation Problem. Cambridge, Mass.: Harvard University. 1965. 427p.
- Morrison, J. W. and Moores, C. R. The Application of Analog Computers to Traffic Intersection Problems. Tucson, Ariz.: Arizona State University, December 1962.
- Neuzil, Dennis R. "Uses and Abuses of Highway Benefit-Cost Analysis," Sierra Club Bulletin. LIII, January 1968. p. 16-21.
- Olson, P. L. and Rothery, R. W. "Driver Response to the Amber Phase of Traffic Signals," Traffic Engineering. XXXII, February 1962. p. 17-21.
- Owen, Wilfred. The Metropolitan Transportation Problem. Washington, D. C.: The Brookings Institution. 1966. 266p.
- Pinnell, C. and Satterly, G. T. Jr. "Systems Analysis Techniques for the Evaluation of Arterial Street Operation." Paper prepared for Annual Meeting and Transportation Engineering Conferences, American Society of Civil Engineers. October 1962.
- Road Research Laboratory. Department of Scientific and Industrial Research. Research on Road Traffic. London: Her Majesty's Stationery Office. 1965.
- Ruiter, E. R. and Shuldiner, P. W. "Operating Costs at Intersections Obtained from the Simulation of Traffic Flow." Highway Research Record 89, 1963. p. 26-38.

Schwar, J. F. and Puy-Huayre, J., Statistical Methods in Traffic Engineering. Columbus, Ohio: Department of Civil Engineering, Ohio State University. August 1964.

Smerk, George M. Urban Transportation; The Federal Role. Bloomington, Indiana: Indiana University. 1965. 325p.

Soberman, Richard M. Transport Technology for Developing Regions. Cambridge, Mass.: M. I. T. Press. 1966.

. Transport Technology for Developing Regions: A Study of Road Transportation in Venezuela. Cambridge, Mass.: M. I. T. Press. 1967. 177p.

Stark, M. C. "Computer Simulation of Traffic on Nine Blocks of a City Street," Highway Research Board Bulletin, No. 456. Highway Research Board, 1962. p. 40-47.

Traffic Research Corporation. "SIGOP: Traffic Signal Optimization Program: A Computer Program to Calculate Optimum Coordination in a Grid Network of Synchronized Traffic Signals." Final Report to the Bureau of Public Roads, 1966.

"Urban Development Models - New Tools for Planning," Journal of American Institute of Planners. May 1965.

Watjen, W. D. "Computer Simulation of Traffic Behavior Through Three Signals," Traffic Engineering and Control. VI, 1965. p. 623-626.

Weiss, G. H. and Maradudin, A. A. "Some Problems in Traffic Delay," Operations Research. X, 1962. p. 74-104.

Welding, P. I. "Time Series Analyses as Applied to Traffic Flow," Proceedings of the 2nd International Symposium on the Theory of Road Traffic Flow, London, 1963. Paris: Organization for Economic Cooperation and Development, 1965. p. 60-72.

Wilson, George W., et al. The Impact of Highway Investment on Development. Washington, D. C.: The Brookings Institution. 1966.

Wingo, Lowdon, Jr., editor. Cities and Space: The Future Use of Urban Land. Resources for the Future Forum. Baltimore, Md.: Johns Hopkins. 1963.

Wolfe, Roy I. Transportation and Politics. Princeton: Van Nostrand. 1963. 136p.

Womack, J. C. "California Highway Needs," California Highways and Public Works. XLIV, January/February 1967. p. 17.

Cybernation and Transportation - on Film and Tape

America's Traffic Problems.

16mm.

University of California Extension, Berkeley.
Mcgraw-Hill

The Cars in Your Life

Humorous film about North Americans and their affair with their automobiles.

16mm, black and white.

National Film Board of Canada. 1960.

Lewis Mumford on the City Series.

1. The City - Heaven and Hell

The creative and destructive nature of the city in history.

2. The City - Cars or People

Studies the problem of how to make the city accessible while relieving congestion.

27 min. 1963.

3. The City and Its Region.

Can the balance between city and countryside be restored?

27 min. 1963

4. The Heart of the City

The growing deterioration of the heart of the city.

27 min. 1963

5. The City as Man's Home.

Relation between community and personal standards of living.

6. The City and the Future

What can be done in the future to restore the city to its former high place in our civilization. 1963.

National Film Board of Canada.

Transportation Problems in a Cybernated Era.

Tapes produced by Canadian Broadcasting Corp., released by Dr. Robert Theobald, 400 Central Pk. West, N. Y., N. y. 10025.

The Triumph of Technology and the Flight from the Land into the Cities.

Arnold Toynbee discusses the shift of populations to urban areas. The Lee Chapel lecture series.

16mm, color. Pt.1,29 min; Pt.2,29 min; Pt.3,29 min.

Encyclopedia Britannica Films.

CYBERNATION AND AGRICULTURE

- Ackerman, E. A. Technology in American Water Development.
Baltimore: Johns Hopkins. 1959.
- Allee, David. "American Agriculture: Its Resource Issues for
the Coming Years," Daedalus. Fall, 1967.
- Baranson, Jack. Technology for Underdeveloped Areas: An
Annotated Bibliography. Oxford: Pergamon. 1967.
- Baum, E. L.; Diesslin, H; Heady, E. O., editors. Capital and
Credit Needs in a Changing Agriculture. Ames, Iowa: Iowa
State University. 1961. 460p.
- Berlin, Lawrence H. "A New Agricultural Strategy in Latin
America," Int. Development Review. IX, September 1967.
p. 12-14.
- Blackett, P. M. S. "The Ever Widening Gap," Science. CLV,
February 24, 1967. p. 959-964.
- Brittain, R. E. Let There Be Bread. New York: Simon and
Schuster. 1952.
- Clark, Colin. The Economics of Subsistence Agriculture. New
York: St. Martin's. 1966.
- Cochrane, W. W. The City Man's Guide to the Farm Problem.
Minneapolis: University of Minnesota. 1965.
- Coppock, John D. North Atlantic Policy: The Agricultural Gap.
New York: 20th Century Fund. 1963.
- Dixey, Roger, editor. International Explorations of Agricultural
Economics. Ames, Iowa: Iowa State University.
- Halperin, Haim. Agrindus: Integration of Agriculture and
Industries. New York: Praeger. 1963.
- . Food for Man in the Future. Davis, Calif.: Univer-
sity of California at Davis. 1964.
- Heady, Earl O. Agricultural Policy Under Economic Development.
Ames, Iowa: Iowa State University. 1962. 682p.

- Heady, Earl O. and Dillon, John. Agricultural Production Functions. Ames, Iowa: Iowa University. 1961. 667p.
- Heady, E. O.; Haroldson, E. O.; Mayer, L. V.; Tweeten, L. G. Roots of the Farm Problem. Ames, Iowa: Iowa State University. 1965. 224p.
- Heady, E. O. and Tweeter, L. G. Resource Demand and Structure of the Agricultural Industry. Ames, Iowa: Iowa State University. 1963. 650.
- Higbee, E. C. Farms and Farmers in an Urban Age. New York: 20th Century Fund. 1963.
- Hobson, Karl. "The Wheat Shortage is Here," The Farm Journal. August, 1966.
- Iowa State University Center for Agricultural and Economic Development. Smith, M. G. and Christian, C., editors. Adjustments in Agriculture. Ames, Iowa: Iowa State University. 1961. 375p.
- . Dynamics of Land Use. Ames, Iowa: Iowa State University. 1961. 371p.
 - . Economic Development of Agriculture. Ames, Iowa. Iowa State University. 1965. 314p.
 - . Farm Goals in Conflict. Ames, Iowa: Iowa State University. 1964. 251p.
 - . Farmers in the Market Economy. Ames, Iowa: Iowa State University. 1964. 310p.
 - . Food: One Tool in International Economic Development. Ames, Iowa: Iowa State University. 1963. 419p.
 - . Labor Mobility and Population in Agriculture. Ames, Iowa: Iowa State University. 1962. 231p.
 - . Research and Education for Regional and Area Development. Ames, Iowa: Iowa State University. 1966. 287p.
 - . World Food Production and Needs. Ames, Iowa: Iowa State University. 1967, 237p.
- Johnson, Glenn L. Managerial Processes of Midwestern Farmers. Ames, Iowa: Iowa State University. 1962. 224p.

- Lamartine, Yates P. Food, Land and Manpower in Western Europe.
London: St. Martin's. 1960
- Mark, Leo. The Machine in the Garden. New York: Oxford University. 1964.
- Mattson, Howard W. "Food for the World," Int. Science and Technology. December, 1965. p.28.
- McKitterick. "A Mass Attack on Low Productivity in Peasant Agriculture," International Development Review. IX, IX, September 1967. p. 2-6.
- Mellor, John W. The Economics of Agricultural Development. Ithaca, New York: Cornell University. 1966.
- Moore, J. R. and Walsh, R. G., editors. Market Structure of the Agricultural Industries. Ames, Iowa: Iowa State University. 1966. 412p.
- Mosher, A. T. Getting Agriculture Moving: Essentials for Development and Modernization. New York: Praeger. 1966.
- Moseman, A. H. Agricultural Sciences for the Developing Nations. Washington: AAAS Symposium. 1964.
- National Academy of Sciences Symposium. Prospects of the World Food Supply. Washington, D. C.: National Academy of Sciences. 1967.
- National Farm Institute. Farm Prosperity: Imports and Exports. Ames, Iowa: Iowa State University. 1965. 108p.
- . What's Ahead for the Family Farm. Ames, Iowa: Iowa State University. 1966. 100p.
- . Farmers and a Hungry World. Ames, Iowa: Iowa State University. 1967. 104p.
- Norton-Taylor, Duncan. "What the U. S. Can Do About World Hunger," Fortune. LXXIII, June 1966.
- Office of Economic and Cultural Development. Food and Agriculture in Developing Countries. Special annotated bibliography #3. Paris: OECD Publications. 1967.

- Padfield, H. and Martin, W. E. Farmers, Workers and Machines. Tucson, Arizona: University of Arizona. 1965.
- Pincus, John. Trade, Aid and Development: the Rich and Poor Nations. New York: McGraw-Hill. 1967. 400p.
- Rehovoth Conference on Comprehensive Planning of Agriculture in Developing Countries. Cleveland, Ohio: Western Reserve University. 1963.
- Sarrett, H.: editor. Resources for the Future. Baltimore, Md.: Johns Hopkins. 1959.
- Scarseth, George P. Man and His Earth. Ames, Iowa: Iowa State University. 1962. 200p.
- Shepherd, Geoffrey S. Farm Policy: New Directions. Ames, Iowa: Iowa State University. 1964. 292p.
- . Marketing Farm Products. Ames, Iowa: Iowa State University. 1965. 522p.
- Solow, Robert M. "Where the Jobs Go and Where They Come From," Think, May/June 1967. p.2.
- Stolper, Wolfgang F. Planning Without Facts. Cambridge, Mass.: Harvard University. 1966. 348p.
- Street, James H. The New Revolution in the Cotton Economy: Mechanization and its Consequences. Chapel Hill: University of North Carolina. 1957.
- U. S. Department of Agriculture. Power to Produce: The Yearbook of Agriculture. Washington, D. C.: U. S. Government Printing Office. 1966.
- Wagner, Phillip. The Human Use of the Earth. New York: The Free Press of Glencoe. 1964. 270p.
- Cybernation and Agriculture - on Film and Tape
- Bread From Stone.
Discusses agricultural efficiency and productivity.
16mm, color, 16 min.
National Plant Food Institute, Film Department.

Can the Earth Provide?

Will science and technology be able to feed mankind?

16mm.

McGraw-Hill Book Co., Text-Film Department

The Farm Problem.

Reasons for the farmer's problems in an industrialized age.

5d, 1 track, 7½ i. p. s., 15 min.

University of Colorado, National Tape Repository

Bureau of A-V Instruction.

Farmer: Feast or Famine.

Examines the farm problem as it appears in the mid-sixties. The replacement of farm laborers by machines.

16mm, black and white, 28 min.

CBS - 20th Century, 1965.

Land.

Documents the decline of the small American Agricultural community and examines the possibility of approaching extinction of the small farm.

black and white, 27 min.

National Broadcasting Company, 1962.

A-V Library, Central Washington State College

BIBLIOGRAPHY

CYBERNATION AND ART

- Angus, Sylvia. "It's Pretty, but is it Art?" Saturday Review.
L, September 2, 1967. p. 14-15.
- Banham, Reyner. Theory and Design in the First Machine Age.
New York: Praeger. 1960. 338p.
- Bauer, Marion. Twentieth Century Music. New York: Putnam.
1947.
- Berckelaers, Ferdinand L. Abstract Painting. New York:
Abrams. 1962.
- Bernier, Georges, and Bernier, Rosamund. Modern Art Yesterday
and Tomorrow. An Anthology on Modern Art, from L'Oeil.
New York: Reynal. 1960.
- Bork, Alfred M. "Randomness and the 20th Century," Antioch
Review. XXVII, Spring, 1967.
- Bowles, Edmund A. Computers in Humanistic Research. Engle-
wood Cliffs, N. J.: Prentice-Hall. 1967. 264p.
- Fink, Donald. "Computer's Creative Promise," Engineer. VIII,
March/April, 1967.
- Munro, T. The Arts and their Inter-relations. New York:
Liberal Arts Press. 1949.
- Canaday, John. Metropolitan Seminars in Art. Portfolio 1-12.
New York: Metropolitan Museum of Art. 1958-59.
- Cheney, Sheldon, and Cheney, Martha C, Art and the Machine.
New York: Wh. Heseey House. 1936.
- Copland, Aaron. Copland on Music. Garden City, New York:
Doubleday. 1960.
- Faulkner, Ray N.; Ziegfeld, Edwin; Hill, Gerald. Art Today:
An Introduction to the Fine and Functional Arts. 2nd ed.
New York: Holt, Rinehart and Winston. 1963.

- Gilson, Etienne. Forms and Substances in Art. New York: Scribner's. 1965. 282p.
- Gordon, J. Geometric Abstraction in America. Whitney Museum of American Art. New York: Preger. 1962.
- Hansen, Peter S. An Introduction to Twentieth Century Music. Boston: Allyn and Bacon. 1961.
- Hardwick, Elisabeth. "Notes on Leonardo and the Future of the Past," Art in America. LIV, March, 1966. p. 33-39.
- Hartford, Huntington. Art or Anarchy. Garden City, New York: Doubleday. 1964. 204p.
- Henning, Edward B. Paths of Abstract Art. Cleveland Museum of Art. New York: Abrams. 1960.
- Hodin, Josef Paul. The Dilemma of Being Modern. New York: Noonday Press, 1959.
- Johnson, Martin. Art and Scientific Thought. London: Faber and Faber. 1944. 192p.
- Kandinsky, Wassily. Point and Line to Plane. New York: Solomon R. Guggenheim Foundation. 1947.
- Kepes, Gyorgy. "The Artist's Response to the Scientific World," Technology and Culture in Perspective. M. I. T. Seminar on Technology and Culture, edited by Ilone Montena. Boston: The Church Society for College Work. February, 1967. 35p.
- Kepes, Gyorgy, editor. The New Landscape in Art and Science. Chicago: P. Theobald. 1963.
- Kepes, Gyorgy, editor. The New Landscape in Art and Science. Chicago: P. Theobald. 1936.
- Kepes, Gyorgy. Structure in Art and Science. New York: Braziller. 1965.
- Kuh, Katherine. Art Has Many Faces. New York: Harper. 1951.
- Lippard, Lucy R. Pop Art. New York: Praeger. 1966.
- Lynton, Norbert. The Modern World. New York: McGraw-Hill. 1965.

- Mathews, M. V. "The Digital Computer as a Musical Instrument," Science. CXLII, November 1, 1963, No. 3592. p. 553-557.
- Mondrian, Piet. Plastic Art and Pure Plastic Art. New York: Wittenborn. 1945.
- Nemerov, Howard. "Speculative Equations: Poems, Poets, Computers," American Scholar. XXXVI, Summer 1967.
- Noll, A. Michael. "Computers and the Visual Arts," Design Quarterly 66/67. 1966. p. 65-71.
- Ortega y Gasset, J. The Dehumanization of Art. Garden City, N. Y.: Doubleday. 1956. 187p.
- Pierce, Nan R. "What's Next After Next?" Art in America. LVI, March 1966. p.31-32.
- Pleasants, Henry. The Agony of Modern Music. New York: Simon and Schuster. 1955.
- Rathburn, M. C. and Hayes, Barlett H. Layman's Guide to the Modern Art: Painting for a Scientific Age. New York: Oxford University Press. 1949.
- Read, Sir Herbert E. Art and Industry. New York: Horizon. 1954.
- Read, Sir Herbert E. Art and Society. New York: Schocken. 1966.
- Read, Sir Herbert E. "Atrophied Muscles and Empty Art," in The World in 1984. Vol.2, edited by Nigel Calder. Baltimore, Md.: Penguin Books. 1965. 205p.
- Richman, Robert, editor. The Arts at Mid-Century. New York: Horizon. 1954.
- Rosenberg, Harold. "Vicissitudes of the Square," The New Yorker. XLIII, January 27, 1968. p. 88-92.
- Rosenthal, Erwin. The Changing Concept of Reality in Art. New York: G. Wittenborn. 1962.
- Schoener, Allan. "2066 and All That," Art in America. LIV, March 1966. p. 40-43.

Sypher, Wylie. Rococo to Cubism in Art and Architecture. New York: Vintage Books. 1963. 352p.

Taubman, Howard. "Creativity and Computers," New York Times. June 14, 1966. p. 52.

Todd, John Murray, editor. The Arts, Artists and Thinkers: An Inquiry into the Place of the Arts in Human Life. New York: McMillan. 1958.

Wind, Edgar. Art and Anarchy. New York: Knopf. 1963.

Cybernation and Art - on Film and Tape

The Aesthetic and Moral Problems Concerning Art.

Examples of realism and abstraction in Art.

28mm, black and white.

National Educational Television

Art and Motion.

16mm, color, 16 min.

Encyclopedia Britannica Films

Art and Seeing.

The art of seeing beauty and form in everyday surroundings.

16mm, color, 15 min.

University of Minnesota. A V Ed, Service, 1952.

Cubism.

Aims, and techniques of Cubism.

16mm, color, 17 min.

Cinema 16, Inc.

Exploring Art Systems.

Demonstrates various systems of modern art.

16mm, 22 min.

McGraw-Hill Textfilm

The Fine Arts. NET 54.

Defines fine art, distinguishes between the terms 'liberal' and 'servile' as applied to arts; the revolt of Modern Art.

16mm, color, 28 min.

National Educational Television

Form and Meaning.

Principle of parallelism and contrast in different art forms.

16mm, 24 min.

Rensselaer Polytechnic Institute

Foto Death.

A 'happening' of Claus Oldenburg.
16mm, color, 15 min.
Cinema 16, Inc.

Marcel Duchamp. EBF 58.

Marcel Duchamp discusses his paintings.
16mm, black and white, 30 min.
Encyclopaedia Britannica Films

Modern Music

16mm, color, 29 min.
National Educational Television

Music Studio: Harry Partch

Unconventional music and instruments.
16mm, color, 18 min.
Cinema 16, Inc.

The Musicwriter.

Explains the music writer machine.
16mm, 10 min.
Thorne Films, Inc.

Technology and the Fine Arts. CSDI 63. (tape)

Andre Malraux's concept of a museum without walls,
and the impact of technology on the arts, with
William Gorman and Clifton Fadiman.
7d, 3 3/4 i. p. s ., 60 min.
Center for the Study of Democratic Institutions.

What is a Painting?

Comparison of works by Leonardo, Renoir, Braque, Mondrian,
ect.
16mm, color, 22 min.
Book of the Month Club

BIBLIOGRAPHY

COMPUTERS

- Adler, I. Thinking Machines. New York: John Day. 1961. 189p.
- Anderson, C. An Introduction to ALGOL 60. Reading, Mass.: Addison-Wesley. 1964.
- Andrew, A. M. Brains and Computers. Toronto, Canada: Harrap. 1963. 78p.
- Arden, B. W. An Introduction to Digital Computing. Reading, Mass.: Addison-Wesley. 1963. 389.
- Arnold, P., and White, P. The Automation Age. New York: Holiday. 1963. 197p.
- Berkeley, Edmund C. Giant Brains: or Machines That Think. New York: John Wiley & Sons. 1949. 294p.
- Bernstein, Jeremy. The Analytical Engine. New York: Random House. 1963. 113p.
- Braden, Robert T. and Perlis, Alan J. An Introductory Course in Computer Programming. Monograph No.7. Discrete System Concepts Project, National Science Foundation Grant No. GE-2546. Pittsburgh, Pa.: Carnegie Institute of Technology. 1965. 123p.
- Calingaert, P. Principles of Computation. Reading, Mass.: Addison-Wesley. 1965. 200p.
- Crowley, Thomas H. Understanding Computers. New York: McGraw-Hill. 1967. 142p.
- Davidson, C. H. and Koenig, Eldo C. Computers: Introduction to Computers and Applied Computing Concepts. New York: John Wiley & Sons. 1967. 596p.
- Desmonde, W. H. Computers and Their Uses. Englewood Cliffs, N. J.: Prentice-Hall. 1964. 296p.
- Dimitry, Donald, and Mott, Thomas, Jr. Introduction to Fortran IV Programming. New York: Holt, Rinehart & Winston. 1966. 334p.

- Fink, Donald G. Computers and the Human Mind: An Introduction to Artificial Intelligence. Science Study Series. Garden City, N.Y.: Doubleday Anchor Books. 1966. 301p.
- Golden, James T, Fortran IV Programming and Computing. Series in Automatic Computation. Englewood Cliffs, N.J.: Prentice-Hall. 1965. 270p.
- Gruenberger, F. J. and McCracken, D. D. Introduction to Electronic Computers. New York: John Wiley & Sons. 1963.
- Haas, G. Design and Operation of Digital Computers. New York: Bobbs-Merrill. 1963. 272p.
- Haberman, Charles M. Use of Digital Computers For Engineering Applications. Columbus, Ohio: Charles E. Merrill. 1966. 278p.
- Harris, L. Dale. Fortran Programming (II & IV). Columbus, Ohio: Charles E. Merrill. 1964.
- IBM. General Information Manual. 1969. 95p.
- Korn, G. A., and Korn, T. M. Electronic Analog Computers. New York: McGraw-Hill. 1956.
- McCormick, E. M. Digital Computer Primer. New York: McGraw-Hill. 1959. 214p.
- McCracken, D. D. Digital Computer Programming. New York: John Wiley & Sons. 1957.
- . A Guide to ALGOL Programming. New York. John Wiley & Sons. 1962.
- Organick, Elliot I. A Fortran Primer. Reading, Mass.: Addison-Wesley. 1963.
- Pfeiffer, J. P. The Thinking Machine. Philadelphia, Md.: Lippincott. 1962. 242p.
- Sherman, P. M. Programming and Coding Digital Computers. New York: Wiley. 1963.
- Weiss, E. A. Programming the IBM 1620. New York McGraw-Hill. 1965.

APPENDIX

TABLE 1

Designation	Memory Core Size (in thousands of words)	Word Size (bits)	Addition Time (micro- seconds)
Large (high order systems)	16 to 262	48	0.2
	512 to 1,024	8	0.18
	16 to 262	64	1.5
	32 to 131	60	0.1
Medium (mid range systems)	32 to 262	48	2.0
	32 to 65	36	4.0
	16 to 32	48	2.6
	40 to 100	variable	33.9
	32 to 65	24	3.5
	4 to 65	18	10.0
	4 to 32	24	3.8
Small ("Desktop" systems)	4 to 32	12	3.0
	4 to	32	7,350.0
	1 to 2	32	6,000.0
	4 to 32	12	2,300.0
	20 to 60	1(dec.)	560.0

FORTRAN CODING FORM

Program	SAN JOSE STATE COLLEGE DIVISION OF ENGINEERING	Page	of	Identification
Programmer	Date	73	73	80

STATEMENT NUMBER	C FOR COMMENT	5	6	7	10	15	20	25	30	35	40	45	50	55	60	65	70	72	
C																			
1																			
5																			
6																			
8																			
2																			
3																			
0.90																			



FORTRAN CODING FORM

Program	SAN JOSE STATE COLLEGE DIVISION OF ENGINEERING		Page	of
Programmer	Date		73	70 72

STATEMENT NUMBER	FORTRAN STATEMENT	70	72
1	COMPUTE THE AVERAGE VALUES OF POSITIVE NUMBERS ONLY.		
	SUMX = 0.0		
	N = 0		
1	FORMAT (15F4.1)		
3	DO 6 I = 1, 15		
	READ I, FN		
	IF (FN) 6, 4, 4		
4	SUMX = SUMX + FN		
	N = N + 1		
	YN = N		
6	CONTINUE		
	AVER = SUMX / YN		
	PUNCH 10, AVER		
10	FORMAT (21H THE AVERAGE VALUE IS, F10.6)		
	STOP		
	END		
	16.250.2-2.241.950.003.380.9-6.631.916.217.000.347.232.237.6 (DATA CARD)		

FORTRAN CODING FORM

Programmer	SAN JOSE STATE COLLEGE DIVISION OF ENGINEERING	Page	73	of	80
Date					

STATEMENT NUMBER	C	FOR COMMENT	30	35	40	45	50	55	60	65	70	72
C		SELECT LARGEST VALUE OF 100 NUMBERS										
1		FORMAT (F10.3)										
		DIMENSION X(100)										
		J = 1										
		READ I, X(J)										
		XMAX = X(J)										
10		J = J + 1										
		IF (J - 100) 20, 20, 40										
20		READ I, X(J)										
		IF (XMAX - X(J)) 30, 30, 10										
30		XMAX = X(J)										
		GO TO 10										
40		PUNCH I, XMAX										
		STOP										
		END										
C		100 DATA CARDS ONE NUMBER PER CARD										

FORTRAN CODING FORM

Program	SAN JOSE STATE COLLEGE		Page	of
Programmer	DIVISION OF ENGINEERING		73	80
Date				

STATEMENT NUMBER	FORTRAN STATEMENT	70	75	80
C	SQUARE ROOT SUBROUTINE			
1	FORMAT(7,HNUMBER=,F11.5,3X,SHRDT=,F10.5,3X,CHITER=,I3)			
2	FORMAT(3,F10.5)			
	DIMENSION Y(3)			
	READ 2,(Y(I),I=1,3)			
	DØ 10 I=1,3			
	Q = 1.0			
	K = 0			
12	X = Q			
	Q = (Y(I)/X+X)+0.5			
	K = K+1			
	IF (Q-X) 12,10,12			
10	PUNCH 1, Y(I), X, K			
	STOP			
	END			
.0063	5621.0 36.0 ← DATA CARD			

FORTRAN CODING FORM

Program	SAN JOSE STATE COLLEGE		Page	of
Programmer	DIVISION OF ENGINEERING		73	80
Date				

STATEMENT NUMBER	FORTRAN STATEMENT	70	72
1			
2			
3			
4			
5			
6			
7			
10	FIND AN INTEGER NUMBER SQUARED LESS 2 EQUAL TO A MULTIPLE OF 19.		
15	A = 10.		
20	B = 0.0		
25	C = 0.0		
30	D = 0.0		
35	N = 0		
40	A = A + 1.0		
45	B = A * A - 2.0		
50	C = B / 19.0		
55	N = C		
60	D = N		
65	IF (A - 1000.0) 30, 60, 60		
70	IF (C - D) 10, 40, 10		
75	PUNCH 50, A		
80	FORMAT (F10.4)		
85	STOP 10		
90	STOP		
95	END		

C FOR COMMENT



FORTRAN CODING FORM

Program	SAN JOSE STATE COLLEGE DIVISION OF ENGINEERING		Page	of	Identification
Programmer			73	60	60
	Date				

	STATEMENT NUMBER	FORTRAN STATEMENT	30	35	40	45	50	55	60	65	70	72
	1											
	2											
	3											
	4											
	5											
	6											
	7											
	8											
	9											
	10											
	11											
	12											
	13											
	14											
	15											
	16											
	17											
	18											
	19											
	20											
	21											
	22											
	23											
	24											
	25											
	26											
	27											
	28											
	29											
	30											
	31											
	32											
	33											
	34											
	35											
	36											
	37											
	38											
	39											
	40											
	41											
	42											
	43											
	44											
	45											
	46											
	47											
	48											
	49											
	50											
	51											
	52											
	53											
	54											
	55											
	56											
	57											
	58											
	59											
	60											
	61											
	62											
	63											
	64											
	65											
	66											
	67											
	68											
	69											
	70											
	71											
	72											



FORTRAN CODING FORM

Program	SAN JOSE STATE COLLEGE DIVISION OF ENGINEERING		Page	of
Programmer:	Date	<div style="display: flex; justify-content: space-between; width: 100%;"> 73 70 </div>		

	STATEMENT NUMBER	FORTRAN STATEMENT	30	35	40	45	50	55	60	65	70	72
	5											
	6											
	7											
	1	C	ONE HUNDRED VALUES OF POLYNOMIAL - Y = X⁴ - 2X³ + X² + 10X + 3, X = 1 TO 100.									
			X = 0.0									
			DO 2 I = 1, 100									
			X = X + 1.0									
			Y = X**4 - 2.0 * X**3 + X * X + 10.0 * X + 3.0									
			PRINT 1, X, Y									
	1		FORMAT (23HTHE VALUE OF Y WHEN X = , F3.0, 4HIS = , F8.0)									
	2		CONTINUE									
			STOP									
			END									
			(NO DATA CARD REQUIRED)									



FORTRAN CODING FORM

Program	SAN JOSE STATE COLLEGE		Page	of
Programmer	DIVISION OF ENGINEERING		73	80
	Date			

STATEMENT NUMBER	FORTRAN STATEMENT
1	C
2	HYPOTHENUSE OF A RIGHT TRIANGLE - TWO LEGS GIVEN.
3	FORMAT (2F10.4)
4	FORMAT (13HF0R.TRIANGLE., F10.4, 4HAND., F10.4, 14HHYPOTHENUSE.13,F10.4)
5	READ 1, A, B
6	PHT = SQRT(A**2 + B**2)
7	PUNCH 3, A, B, PHT
8	IF(A) 2, 4, 2
9	STOP
10	END
11	63.19 12.802 (SAMPLE DATA CARD - MORE THAN ONE CAN BE USED LAST CARD WILL HAVE A ZERO VALUE FOR A & B OF A BLANK CARD)