

ED 028 253

VT 007 319

By Perlberg, Arye, And Others

The Use of Portable Video Tape Recorders and Micro-Teaching Techniques to Improve Instruction in Vocational-Technical Programs in Illinois; A Pilot Study. Final Report. Studies One and Two.

Illinois Univ., Urbana. Dept. of Vocational and Technical Education.

Spons Agency- Illinois Research and Development Coordinating Unit, Springfield.

Pub Date 68

Note- 133p.

EDRS Price MF-\$0.75 HC-\$6.75

Descriptors- Audiovisual Instruction, Behavior Change, Equipment Utilization, Inservice Education, *Microteaching, *Pilot Projects, Practicum Supervision, Preservice Education, *Teacher Education, *Video Tape Recordings, *Vocational Education Teachers

A two-part pilot study was conducted to examine the feasibility aspects and problems encountered in the experimentation and adaptation of the portable video recorder and micro-teaching techniques. The effective adoption of these innovations to vocational-technical teacher education programs requires systematic research and experimentation. Study Number One "Improving Inservice Education," proposes that a confrontation of his classroom behavior on video tape recordings will increase the teachers' awareness of the need to modify certain behavioral patterns in the classroom. A systematic analysis of the video tape and the development of competency in specific teaching skills through micro-teaching will facilitate this change. Study Number Two "Improving Student Teaching," hypothesizes that the augmentation of regular method courses with experiences in a micro-teaching laboratory during the student period by the student teacher, cooperating teachers, and college supervisor would improve the preparation of perspective student teachers. The methods, findings, conclusions and recommendations as well as technical details for using the equipment, a bibliography and review of literature are included in the document. (FP)

ED 028 253

VT 007 319

By Perlberg, Arye, And Others

The Use of Portable Video Tape Recorders and Micro-Teaching Techniques to Improve Instruction in Vocational-Technical Programs in Illinois; A Pilot Study. Final Report. Studies One and Two.

Illinois Univ., Urbana. Dept. of Vocational and Technical Education.

Spons Agency- Illinois Research and Development Coordinating Unit, Springfield.

Pub Date 68

Note- 133p.

EDRS Price MF-\$0.75 HC-\$6.75

Descriptors- Audiovisual Instruction, Behavior Change, Equipment Utilization, Inservice Education, *Microteaching, *Pilot Projects, Practicum Supervision, Preservice Education, *Teacher Education, *Video Tape Recordings, *Vocational Education Teachers

A two-part pilot study was conducted to examine the feasibility aspects and problems encountered in the experimentation and adaptation of the portable video recorder and micro-teaching techniques. The effective adoption of these innovations to vocational-technical teacher education programs requires systematic research and experimentation. Study Number One "Improving Inservice Education," proposes that a confrontation of his classroom behavior on video tape recordings will increase the teachers' awareness of the need to modify certain behavioral patterns in the classroom. A systematic analysis of the video tape and the development of competency in specific teaching skills through micro-teaching will facilitate this change. Study Number Two "Improving Student Teaching," hypothesizes that the augmentation of regular method courses with experiences in a micro-teaching laboratory during the student period by the student teacher, cooperating teachers, and college supervisor would improve the preparation of perspective student teachers. The methods, findings, conclusions and recommendations as well as technical details for using the equipment, a bibliography and review of literature are included in the document. (FP)

THE USE OF VIDEO
TAPE RECORDERS AND
MICRO-TEACHING TECHNIQUES
TO IMPROVE INSTRUCTION IN
VOCATIONAL-TECHNICAL
PROGRAMS IN ILLINOIS

FINAL REPORT

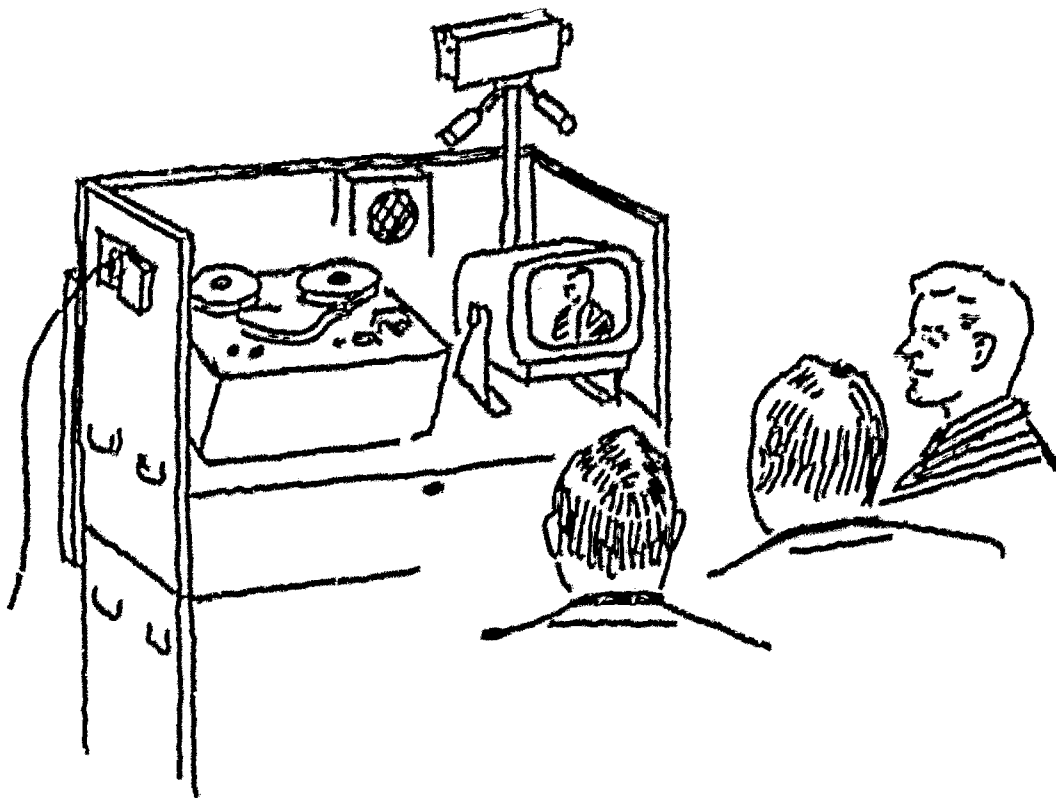

A. PERLBERG
R. TINKHAM
R. NELSON

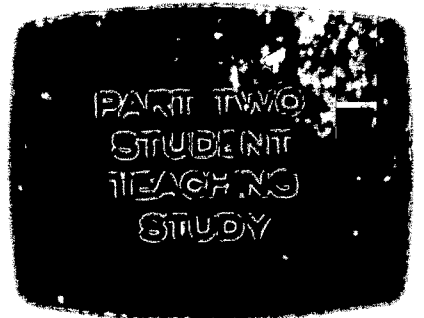

VT007319

Conducted by the Department of Vocational and Technical Education, College of Education,
University of Illinois

In cooperation with the Illinois Board of Vocational Education and Rehabilitation

THE USE OF PORTABLE VIDEO TAPE RECORDERS AND MICRO-TEACHING TECHNIQUES
TO IMPROVE INSTRUCTION IN VOCATIONAL-TECHNICAL PROGRAMS IN ILLINOIS .

A PILOT STUDY .

Arye Perlberg, Director*
Robert A. Tinkham, Co-Director
Richard L. Nelson, Research Associate

FINAL REPORT .

Study Number Two: Improving Student Teaching -

September 15, 1967 to August 15, 1968

Department of Vocational and Technical Education,
College of Education
University of Illinois
Urbana, Illinois

in cooperation with

Research Coordinating Unit
Vocational and Technical Education Division
Board of Vocational Education and Rehabilitation

U.S. DEPARTMENT OF HEALTH, EDUCATION & WELFARE
OFFICE OF EDUCATION

THIS DOCUMENT HAS BEEN REPRODUCED EXACTLY AS RECEIVED FROM THE
PERSON OR ORGANIZATION ORIGINATING IT. POINTS OF VIEW OR OPINIONS
STATED DO NOT NECESSARILY REPRESENT OFFICIAL OFFICE OF EDUCATION
POSITION OR POLICY.

*Dr. Arye Perlberg is a Visiting Associate Professor in the Departments of Vocational and Technical Education, College of Education and General Engineering, College of Engineering, University of Illinois, Urbana. He is on leave from the Technion-Israel Institute of Technology, Haifa, Israel.

Dr. Robert A. Tinkham, Associate Professor of Industrial Education in the College of Education at the University of Illinois, is head supervisor of industrial education student teachers.

Mr. Richard L. Nelson is a research associate who served as Assistant Supervisor of Industrial Education student teachers at the University of Illinois.

PREFACE

Traditionally, in the United States and more so the world over, the preservice and in-service development of pedagogical competencies of vocational-technical teachers has been slighted. Emphasis has been placed on developing competency in technical skills and theoretical subject matter relating to a trade or occupation. These skills were acquired mainly through occupational experience and some type of formal learning. It was natural for vocational-technical educators to assume that the pedagogical skills would also be acquired through practical experience, trial and error.

In recent years there has been, however, a growing realization among vocational-technical educators that formal professional education should receive greater attention than it has been given in the past. There is an awareness of the need to expand existing programs and improve their quality. It is essential, however, that steps in this direction include an examination of evolving changes and application of innovations in the general area of teacher education and an evaluation of their potentialities for vocational-technical teacher education.

Two innovations, portable video recorders and micro-teaching techniques, have captured the attention of teacher educators in recent years. A growing number of educational institutions across the country are investigating the potential inherent in these new techniques and media for preservice teacher education and the improvement of instruction of experienced teachers. At the University of Illinois, the College of Education has established a micro-teaching laboratory equipped with portable video tape recorders to improve the training of new teachers. The Department of General Engineering has been engaged in a project using these techniques to improve instruction on the higher education level.

In comparison to other segments of the educational community, vocational-technical education has been slow in exploring the possibilities inherent in these innovations. The study reported herein is one of the first conducted by vocational-technical educators on the adoption of these techniques and media.

The effective adoption of video tape recordings and micro-teaching techniques to vocational-technical teacher education requires systematic research and experimentation. Before such detailed structural studies are undertaken, however, there is need for pilot studies to explore and examine the feasibility aspects and the problems encountered in the experimentation and adoption of these innovations.

The following is a report of such an exploration. This study was conducted in the Department of Vocational and Technical Education, College of Education, at the University of Illinois in Urbana, and supported by a grant from the Research Coordinating Unit, Division of Vocational and Technical Education, Illinois State Board of Vocational and Technical Education and Rehabilitation. The investigation has been conducted in two areas: (1) in-service training programs in area vocational schools and the vocational-technical programs of junior colleges and (2) training and supervising student teachers in vocational-technical education. Aspects of each study and the findings and analysis will be presented in separate reports.

ACKNOWLEDGEMENTS

Many individuals and agencies made this study possible and we are indebted to all of them. The project director wishes to acknowledge in particular the Dean of the College of Education, Rupert N. Evans, and the Head of the Department of Vocational and Technical Education, M. Ray Karnes, for inviting him to spend his sabbatical in full-time research at the University of Illinois.

Professor Dwight Allen, one of the originators of Micro-Teaching, formerly at Stanford University and at present Dean of the School of Education at the University of Massachusetts, Amherst, has provided advice, materials, and constant encouragement for which the researchers are indebted.

The Illinois Research Coordinating Unit (RCU), the Vocational Technical Education Division, Board of Vocational Education and Rehabilitation, provided funds for this project. We acknowledge especially the encouragement given by Vernon E. Burgener, RCU Coordinator of Research, and Robert K. Gray, Research Consultant. The University of Illinois, through its College of Education and the Department of Vocational and Technical Education, provided advice and encouragement in the preparation of the research proposal and during the research activities.

Professor William D. Johnson of the College of Education, Teaching Techniques Laboratory, has consulted with the researchers and encouraged students participating in this project to use the Teaching Techniques Laboratory services.

We acknowledge the cooperation of our colleagues, Professors Mary Mather and Paul Hemp, and their associates, Kenneth Knell, Mrs. Bessie Hackett and Alfred Mannebach, in allowing us to pursue this research with some of their student teachers and cooperating teachers. We are also indebted to the participating student teachers, cooperating teachers, and their schools for their cooperation.

Michael Alig, of the College of Education Television Center, helped to develop and maintain our video recorder system in excellent working condition. We would like to express our appreciation to Miss Ruth Gorrell and the typists in the Stenographic Office for typing the final manuscript of this report.

Last, but not least, we are especially indebted to Miss Lois Oldham who labored with us in typing and editing the many drafts of this report.

TABLE OF CONTENTS

	Page
Preface	iii
Acknowledgements	v
CHAPTER	
I. Introduction	1
II. Feedback Processes and Micro-Teaching Techniques in Student Teaching Supervision	7
III. Findings and Discussion	11
IV. Video Tape Recording Systems: Technical Aspects	19
V. Conclusions and Recommendations	28
Bibliography	33
APPENDIX	
A. Excerpts from Student Teacher and Cooperating Teacher Reactions	
B1. Equipment	
B2. Transporting Equipment	
B3. Special Effects Equipment	
C1. Instructions for Setting Up and Operating Mobile Video Center	
C2. Instructions for Setting Up and Operating Portable Video Center	
D. Developing Model Tapes on One-Half-Inch Sony Equipment	
E. Participants	
F. Teacher Performance Appraisal Scale	

CHAPTER I

INTRODUCTION

Supervised Student Teaching

The importance of supervised practice in the education of trainees is recognized in all professions and skilled trades. Supervised student teaching is widely acclaimed as one of the most important facets in the process of teacher education. Even though the value of supervised teaching has yet to be demonstrated by controlled experimental research,^{1/} it is accepted as imperative in teacher education.

Conant's criticism of the education of the American teacher^{2/} has stirred considerable controversy; however, one of his suggestions that has been widely applauded even by critics is the establishment of the position of a "clinical professor of education," who would be recognized especially for the quality of his teaching and would have primary responsibility for the student teachers during their induction into classroom teaching.

Existing techniques and procedures of student teaching required by the profession and by institutions preparing teachers should not be considered as an "optimum" reached by research, but rather a result of trial and error and in many cases a compromise between desired goals and reality. It is realized that student teacher activities should be increased in scope and depth. However, there is a shortage of highly competent cooperating or master teachers, university supervisory personnel, and adequate funds to conduct such desired programs. Other weaknesses of existing practices in student teaching are due to lack of understanding and agreement regarding the nature of classroom learning, teaching, and the supervisory process. "Thus, much remains to be accomplished by college supervisors, classroom cooperating teachers, and researchers in establishing definitions of goals in teaching and in assessing the degree to which these goals are promoted through supervision."^{3/} The same is true with other aspects of student teaching practice.

Student Teaching Procedures

Student teaching at the University of Illinois, in vocational-technical subjects (industrial education, agricultural education, and home economics education) consists of day-long attendance at the assigned school for seven calendar weeks. In addition, the student teacher can elect to spend two weeks at the school when it opens in the fall.

^{1/} Oliver, D.W. and Shaver, J.P. "A Critique of 'Practice Teaching'," Harvard Educational Review, Vol. 31, 1961, pp. 437-443.

^{2/} Conant, J.B. The Education of American Teachers, New York: McGraw-Hill, 1963.

^{3/} Schueler, H., Lesser, G.S., and Bobbins, A.L. Teacher Education and the New Media, Washington, D. C.: American Association of Colleges for Teacher Education, 1967, p. 85.

The typical student teacher's activities (in chronological order) include the two-week observation period in the assigned school, seven weeks in an on-campus methods course, seven weeks at the assigned school for student teaching, and two weeks of review and analysis of his experiences. Students may do their student teaching either in the fall or spring semester. However, the student teacher in the spring semester is at a disadvantage because he must wait six months after the observation period to begin his student teaching.

Supervisory calls are specified as three one-half day visits during the regular period with no calls required during the two-week opening period. As a general practice among university supervisors, the major objectives for the three calls are as follows: first visit--orientation and planning; second visit--observation of the student teacher presenting a lesson to the class (in industrial education he is required to give a demonstration to one class and a lecture to another); third visit--final evaluation of the student teacher's work.

It is obvious that there is a very limited amount of time for observation of the prospective teacher in a regular classroom since this cannot reasonably be done on the first call and seldom can be added to the work that must be completed during the last visit. In effect, the university supervisor, half-way through the student teaching period, critiques the student teacher's presentations and returns after two or three weeks for his final visit to learn from the cooperating teacher of the progress made by the student teacher. While it is accepted that additional first-hand observation and more adequate time for analysis would improve the student teaching process, the supervisory load for university staff members seldom permits calls beyond the required minimum.

Part of the problem of limited time for supervisory calls lies in the fact that student teachers can be assigned to any school district in the state. To place student teachers with the best cooperating teachers, the university supervisor typically has a sizable amount of traveling to do in spite of his efforts to cut down on travel time by grouping calls geographically.

Cooperating teachers are selected by the university supervisor for their ability to teach pupils and for their skill in guiding student teachers. Although considerable latitude is given, the cooperating teacher knows what is expected of the student teacher and plans his activities accordingly. It should be noted that the College of Education does not conduct a formal program to prepare cooperating teachers for their roles. The Office of Student Teaching, however, issues a guide for cooperating teachers and some departments conduct orientation programs.

One other factor in the traditional student teaching situation should be considered and this is the limited amount of time available to some cooperating teachers to consult with and guide their student teachers. For a few, there is only a minimum amount of time available during the day for essential work of this nature.

From the above description, it would seem evident that present student teaching practices could be greatly improved and that much more could be done to prepare student teachers for their teaching tasks. The following is a description of a pilot study in which it was hypothesized that the augmentation of regular methods courses with experiences in a micro-teaching laboratory during the student teaching period by the student teacher, cooperating teachers, and college supervisor would improve the preparation of prospective student teachers.

The Purpose and Objectives of the Study

The purpose of this study was to validate the following hypotheses: (1) the augmentation of methods courses before the student teaching period with practice in the college micro-teaching laboratory utilizing video recording would provide students with a realistic teaching experience and ease the anxieties of their induction into student teaching; (2) the use of micro-teaching techniques and video recordings by the student teacher and cooperating teacher during the student teaching period would better prepare the student teacher for his role; (3) the use of video tape recordings and systematic observational techniques to analyze these tapes by the college supervisor would augment the limited number of visits to the student teacher, and (4) the critique of video recordings of the student teacher's classroom presentations by means of a telephone conference with the student teacher and the cooperating teacher will improve the supervisory process.

Specific objectives of the study were as follows:

1. To explore the use of video tape recordings (VTR's) and micro-teaching techniques (MIT's)* for self-appraisal and self-instruction by the student teacher during the student teaching period.

* In keeping with the overall purpose and the title of the Project, the term "Micro-Teaching Techniques" (MIT's), has been included in the above objectives although it was not included in the specific objectives of the original study proposal. It was also stated in the research proposal that student teachers would be acquainted with VTR's and MIT's through their methods courses and experiences in the teaching techniques laboratory.

2. To explore the uses of VTR's and MTT's in the daily supervisory process conducted by the cooperating teacher
3. To explore the uses of VTR's as feedback mechanisms to increase the effectiveness of the college supervisor during his regular visits in evaluating and suggesting improvements in the work of the student teacher.
4. To explore and evaluate the possibilities and benefits of VTR's made in the school and sent to the college supervisor for analysis and critique.
5. To develop a collection of selected VTR's which will serve to illustrate critical teaching incidents and models for discussion purposes with individual student teachers and in college methods courses.
6. To develop a working plan for the introduction of VTR's into the regular supervisory program for student teaching in vocational-technical education. Such a plan should include suggestions regarding equipment, supplies, budget, personnel, administration, and training.

Research Method

This pilot study was designed to obtain qualitative data, which are essential for the design of a structured research project to evaluate, in qualitative measures, the effectiveness of these media and techniques. The findings of this study and its implications should be viewed as tentative until further research data are attained to support them.

Description of Activities

1. Student Teacher Activities in Teaching Methods Courses Prior to Student Teaching. Twenty-one student teachers in the Department of Vocational and Technical Education who participated in the study taught several lessons in the Teaching Technique Laboratory sponsored by the Office of Student Teaching in the College of Education. The TTL was established and directed by Professor William Johnson of the College of Education.* They were introduced to teaching skills such as demonstration techniques, use of audio-visual aids in introducing a unit of instruction, questioning techniques which stimulate classroom interaction, and sensitivity to nonverbal communication. Each lesson emphasized one of these skills. Three lessons were taught by

* The TTL engages in an evaluation of its activities with all participating students. The following analysis, however, pertains only to students participating in this study.

each student teacher during the fall semester and five lessons during the spring. Student teachers were familiarized with the operation of portable video recorders in the classroom and with the use of VTR's as feedback mechanisms in analyzing the teaching process. The purpose of this instruction was to enable them to use these media and techniques when equipment was brought to their schools during the seven weeks of student teaching. Some instruction on technical problems also was given in the methods course.

2. Workshop for Cooperating Teachers. A one-day orientation session was conducted for cooperating teachers just prior to student teaching. They received training in the operation of the video tape equipment and were also introduced to the rationale and uses of the micro-teaching techniques. The project's research procedures were also discussed.

3. Activities During the Student Teaching Period During both semesters, each participating student teacher had one set of equipment for two to four days on each of several (two or three) occasions. Assignments of the equipment coinciding with the university supervisor's visits enabled him to critique the student teacher's tapes. During the first semester, the sets were brought to the schools by the researchers; university students were hired to transport the equipment to assigned schools in the second semester. Upon their arrival in schools, they checked the operation of the equipment with the teachers. In a few cases, student teachers participating in the study were asked to transport equipment. This was done on an experimental basis to determine its feasibility because it was assumed that such a practice would reduce expenses.

The following basic schedule was used to guide the cooperating teacher and student teacher during the time when the equipment was located in their school:

- | | |
|---------|--|
| Phase 1 | Taping of the cooperating teacher and class by the student teacher. |
| Phase 2 | Taping of the student teacher and class by the cooperating teacher for self-appraisal by the student teacher. |
| Phase 3 | Taping of the student teacher and class by the cooperating teacher for analysis and assistance by the cooperating teacher. |

Phase 4 Taping of the student teacher and class by the cooperating teacher. Tapes to be sent to the college supervisor for his analysis, comments, and suggestions, by mail or by telephone conference.

Some of the tapes of the student teacher activities were sent to the college supervisor for his review and critique. After he had analyzed the tape, a telephone conference was arranged to discuss the lesson recorder on the tape. At the university, the college supervisor watched the tape on a television monitor while discussing it on the telephone. Miles away the student teacher and cooperating teacher heard the audio portion of the tape and discussed its content with the supervisor.

Equipment*

To carry out this project, two sets of one-half inch video taping equipment were used, each consisting of two cameras, a recorder, a small TV monitor, three microphones, and an amplifier-mixer which permitted more than one microphone to be used simultaneously. Two different units were designed and built to house the equipment and to transport it between the schools.

The Scope of the Study

The range of activities in this pilot study was limited. The restricted staff time and the availability of equipment forced the researchers to work with a limited number of student teachers.

This study attempted to evaluate the contribution of video recordings and micro-teaching techniques to the supervision of student teachers. Although they participated as part of their methods course in the TTL, no quantitative evaluation was made of these experiences.

* A more detailed discussion of the equipment is presented in Chapter IV of this report.

CHAPTER II

FEEDBACK PROCESSES AND MICRO-TEACHING TECHNIQUES IN STUDENT TEACHING SUPERVISION

Two aspects of the student teaching process were investigated in this study. The first pertains to the feedback mechanism which is one of the most essential factors in the supervisory process, and the second relates to means and techniques of increasing the intensity and effectiveness of the supervisory process as a whole.

Feedback Mechanisms in Supervision

Feedback in student teaching is regularly obtained by recall and selective note-taking by the supervisor. The student teacher, when asked to appraise and critically analyze his performance, must rely primarily on his memory. An experienced teacher might find it difficult to recall in detail many of the variables which take place in the interaction between his pupils and himself. Even more so is this true of the student teacher, who typically is tense and nervous, whether playing a teaching role before his peers or teaching in an actual classroom. The detailed interaction in the classroom and his overall impression are influenced by his emotional state and various defense mechanisms. The image recalled is very subjective and in many instances the teacher may have a partial or complete blackout of many events and variables in the classroom interaction.

As he observes the lesson, the cooperating teacher or college supervisor records critical incidents. These notes, the general recollection of incidents, and his overall impression provide the basis for an analysis and discussion with the student teacher. It is safe to assume that the observer's emotional attitude, personal bias, perceptual distortions, attention limitations, and sensitivity to classroom interaction influence general impressions and note-taking. Moreover, memory lapses alter the picture. These factors have in the past led to differences in recollection and in the perception of situations, and to overt and covert resistance upon the part of the student teacher to accept the supervisor's evaluation and suggestions.

Accurate feedback of behavior plays a cardinal role in the improvement of teaching performance. Feedback facilitates an analysis and comparison of the student teacher's behavior with generally accepted criteria and behavioral objectives. It aids in the reinforcement of approved behavioral patterns and creates dissatisfaction with those which are undesirable. It is, therefore, instrumental in establishing new behavioral objectives and in determining whether they are attained.

Traditionally, a classroom interaction was described in vague terms by teachers and researchers alike. A better understanding of this complex phenomena has been gained in recent years with the development of various methods of observing, analyzing, and measuring classroom behavior (of both teacher and pupils) by systematic observation.^{4/} Many of these systems have since been modified and sophisticated through extensive research. The growing interest in research studies on observational systems of teacher behavior is evident in the number of articles in the literature and the research papers presented at recent conventions.^{5/}

One serious limitation of systematic observation methods is that they are based on the observation and written report of someone whose perception may be impaired by intrinsic factors or from disturbances in the classroom.

The use of audio tape to record classroom activities permits repeated analysis of classroom interaction by several people, thus removing some of the personal distortion. It also enables the teacher involved to analyze his own activities. However, both live and audio systematic observation methods are limited to verbal interaction in the classroom and eliminate many important non-verbal variables inherent in classroom interaction. The supervisor's proposed modification of classroom behavior based on an analysis of verbal interaction alone could be rejected because it does not provide the "whole picture" of what occurs in the classroom.

Feedback through Portable Video Recorders

The utilization of portable video tape recorders permits the recording of events in the classroom with minimum disturbance to the teacher and students. Relatively inexpensive facilities, using two cameras, permit simultaneous recording of the teacher's and students' classroom interaction; both pictures (split screen) are projected by the recorded tape.

Video recording is not new and a number of teachers have been taped in the past, for the most part in television studios, and, in a few cases, in their own classrooms. In many cases, taping of classroom activities in the studio has turned the lesson into a performance. Taping in regular classrooms with extensive, and expensive, television equipment can also disrupt the atmosphere of the classroom and distort the natural process of teacher-student interaction.

^{4/} Medley, D.M. and Mitzel, H.E. "Measuring Classroom Behavior by Systematic Observation," Handbook of Research on Teaching, N.L. Gage (ed.), Chicago: Rand McNally and Company, 1963, pp. 247-328.

^{5/} As reported at the 1967 and 1968 American Educational Research Association Conventions.

The technological innovation of portable video recorders provides an instant, accurate feedback of classroom interaction as a whole (verbal and nonverbal) in the teacher's natural habitat, his classroom. It provides a basis for reliable analysis and decisions about desirable modification in classroom behavior.

The Psychological Impact of Video Recordings

Student teachers, more than experienced teachers, may have ambivalent feelings toward feedback mechanisms. Though they can provide the sense of direction essential for the continuation of any activity, feedback mechanisms may also require a modification of behavior, which can cause uncertainty, discomfort, and even anxiety in the student teacher.

In the past, student teachers have been able to accept unpleasant feedback of their classroom behavior by rationalizing that it was inaccurate and subjective and even distorted by the observer. In many cases, they failed to remember things that were seen and reported. Some of these memory failures may be viewed as defense mechanisms which are instrumental in relieving anxieties created by facing the truth.

An entirely different situation has eventuated with the introduction of portable video recorders. Feedback can now be accurate; defense mechanisms previously employed cannot be used. Reality in its nakedness is available to the student teacher. What he needs now is the desire to confront himself and courage to accept what he sees.

The student teacher's ambivalence of viewing his image is evidenced in feelings of anxiety and curiosity. There is a certain fascination in seeing one's own image; it is the magic of the mirror, the visual echo.^{6/} This narcissistic fascination may motivate him to take the chance and look at himself.

After the student teacher has overcome the anxiety of initial observation, it would seem that nothing would be more convincing to him to modify his teaching behavior than the true picture of his classroom interaction. When used properly, this traumatic self-confrontation can greatly enhance the student teacher's readiness to accept his superior's advice.

There are a number of studies in teacher education and closely related areas, such as counselor training, to verify the effectiveness of video tape recordings and playback techniques of providing knowledge of results, especially behavior modification and the acquisition of complex skills.^{7/}

^{6/} Nielson, G. Studies in Self-Confrontation, Copenhagen: Munkegaard, 1962.
^{7/} See Alexander, Bloom, Kagan, Maccoby, Maier and Schueler in bibliography.

Micro-Teaching Techniques

Micro-teaching^{8/} is a teaching encounter scaled down in class size and time. Micro-class size is usually three to six students and includes a five- to twenty-minute lesson. The purpose of micro-teaching is to provide prospective student teachers with a substantial amount of actual teaching practice before they engage in student teaching at their assigned schools. This is done with optimum control and evaluation procedures without jeopardizing the learning of regular classroom pupils.

The micro-teaching process usually takes place in "teaching laboratories," where video tape recordings are used to provide feedback. In each lesson the student practices a specific skill, such as the ability to lecture, ask questions, lead a discussion, demonstrate, etc. The tape is viewed immediately after the presentation and is critiqued by the student teacher with the aid of a supervisor and by the written feedback of an evaluation questionnaire completed by students in the laboratory classroom. In some cases, an "improved" version of the lesson is planned and taught immediately to another micro-laboratory class. At other times, the new version is taught several days later.

Since its inception, the micro-teaching model has been modified in many ways. However, the innovators have indicated the need for further exploration to find optimal models for the use of micro-teaching in teacher education.^{9/} A growing number of educational researchers are experimenting with modified models of the micro-teaching techniques or combinations of micro-teaching and systematic observational methods. The most common combination is probably micro-teaching and interaction analysis.

Although many of the advantages of micro-teaching techniques and portable video recorders seem logical, much research is needed to prove their validity and to propose optimal uses to increase teacher effectiveness.

^{8/} The term "micro-teaching" was coined by Dwight Allen of the Stanford University Teacher Education Program while he was pioneering in the application of the system to teacher education.

^{9/} Allen, D.W. Micro-Teaching: A Description. Stanford, California: Stanford University, 1967.

CHAPTER III

FINDINGS AND DISCUSSION

The following is a description of the findings, a discussion of problems made evident by project activities, and proposals of strategies to alleviate these problems. The order in which the findings are presented is no indication of their relative importance.

General Attitudes of Students and Cooperating Teachers

From oral discussions and written evaluation of students and cooperating teachers, it is evident that the project activities were considered valuable to most participants. A high degree of cooperation with the researchers on most structured activities was achieved. It must be stressed, however, that a strong "Hawthorne effect" was involved in the participants' attitudes.

It may be assumed also that the novelty of the techniques and the fascination resulting from the technological phenomenon of being able to record one's own image and to see it immediately were influential factors in creating enthusiasm and eagerness to participate. The public's strong identification with television as a media contributed, too, to this strong motivation.

Of great importance were the project's orientation activities and the general permissive, nonthreatening atmosphere introduced by the researchers. It was emphasized that the purpose of the project was to improve instruction rather than to determine a grade.

Although favorable attitudes are a necessary condition, they are not sufficient for optimum utilization of the media and techniques. A discussion of some of the factors which facilitate or hinder their effective use will follow.

The Preparation of Student Teachers for the Use of Video Recordings and Micro-Teaching Techniques During the Student Teaching Period

Student teaching can be a traumatic experience. After years of preparation, the student teacher may not be confident that he can be a successful teacher, and his anxieties about his teaching ability increase in this first phase of his professional career. It is assumed that the student teacher is mature and is equipped with the theoretical knowledge necessary to cope with the many problems which arise in his first days as a teacher. However, reality does not always justify these assumptions. Most professional education training does not provide the neophyte teacher with practical solutions to the problems he faces during the student teaching period.

Student teachers in the Department of Vocational and Technical Education in the 1967-1968 year were introduced to micro-teaching and video recordings by means

of discussion and demonstration held in the methods courses. Students visited the Teaching Techniques Laboratory and observed micro-teaching in practice. Some taught in the laboratory. Student teachers participating in the project were introduced to the study's purposes and procedures and given the opportunity to teach several micro-lessons in the Teaching Techniques Laboratory.

The study results indicate that a thorough knowledge of the media and techniques and an intensive, structured practice in the Teaching Techniques Laboratory during the methods course, facilitate their effective use during the student teaching period. This practice will ease many of the tensions inherent in student teaching. The student teacher arrives at the school equipped not only with theory but also with practical experience in teaching, thus enhancing his status as far as the cooperating teacher and his students are concerned. He will be able to begin teaching during the first week. Having been exposed to critiques of his lessons by supervisors and students in the Teaching Techniques Laboratory, he will be more open to suggestions from the cooperating teacher and may actively request him to critique his instruction in order to maximize the effect of student teaching.

The preparation of student teachers for the effective use of these media and techniques as described in this study did not prove to be adequate. A more intensive program should be introduced.

The initial phase in preparing the student teacher for the use of these innovations begins in the methods course where he learns of the rationale and becomes acquainted with the process of feedback, self-confrontation, and micro-teaching techniques. Intensive practice should be provided in the micro-teaching laboratory or a similar arrangement. Such experiences should offer college credit and be coordinated with the methods course.

The intensity of activities in the micro-teaching laboratory should depend upon the ability of students to learn the use of specified teaching skills and to be relaxed in the self-confrontation process. Individual differences must be taken into consideration. Some students may need ten half-hour sessions while others would require twice that amount of time. The student's readiness to teach in an assigned school should be the criteria for his "graduation" from the laboratory.

In several cases, two student teachers are assigned to the same school. While the researchers did not investigate the advantages and disadvantages of this practice as compared with the assignment of one student per school, they feel that such a practice may ease students' anxieties during the student teaching

period. The sharing of experiences between the two student teachers adds to their learning and also eases the typical loneliness of being in a strange community.

In the case of this study, the presence of two student teachers in one school also solved some technical problems of taping. Few student teachers had time to review the tapes individually. However, the self-confrontation would seem more inhibiting than the time factor. The mutual viewing of the tapes helped ease the inhibition of confrontation and stimulated self-review.

The Role of the Cooperating Teacher

The cooperating teachers were introduced to the project, its purpose and procedures during a one-day workshop. All expressed a desire to cooperate with the researchers in exploring the potential of the media and techniques in improving student teaching. Within the prevailing conditions, they have done their best.

Two conditions are essential for the most efficient use of these media and techniques. A training program for cooperating teachers to prepare them for supervising student teachers and, in particular, the effective use of video tape recordings and micro-teaching techniques is necessary. The second condition is a favorable climate: adequate time and facilities and the incentives to pursue such activities.

The cooperating teachers were advised that it would be desirable for them to be taped in their classrooms. The teachers should analyze these tapes by themselves, with colleagues, or with the student teachers. It was suggested that they use the tape as a model for the student teacher to study and perhaps imitate. Taping and reviewing of tapes set a good example and helped them to pursue the activity with student teachers.

Cooperating teachers were advised that the utilization of VTR's as feedback mechanisms would be helpful in their own self-improvement. Some teachers indicated that for the first time they had the opportunity to see themselves as students saw them and were surprised at the tapes' contents. But in most cases there were a variety of "obstacles" which prevented them from engaging in self-taping and analysis.

The cooperating teacher may have ambivalent feelings and anxieties about self-confrontation on tape. Being the only one in the school who experiments with these media and techniques, he may be reluctant to ask his colleagues to review tapes with him. Inviting the student teacher to review and analyze his classroom interaction with him may be perceived as a threat to his authority

as a supervisor. In several cases, cooperating teachers asked the researchers to review their tapes and critique them.

In order to utilize them the cooperating teacher must be fully acquainted with VTR's and MTT's. Such experience could be provided in a university workshop where participants would have the opportunity to use a MIT laboratory and to assume the role of learner, teacher, and supervisor. The program would include an overview of learning and teaching theory with special emphasis on research in feedback mechanisms and MTT's. The teachers would also be instructed in the operation of equipment to enable them to train others.*

Another goal of the workshop is to enable the teacher to relax while being taped and critiqued and to be able to critique his own tapes. He will have developed sensitivity to classroom interaction and the ability to apply research findings to the teaching-learning process.

The second area which determines the success of the cooperating teacher is the availability of time and the presence of incentives to engage in this work. In the present system, cooperating teachers have limited time to devote to the supervision and guidance of the student teacher. Very seldom is the load of the teacher reduced when he accepts additional duty of supervision of student teachers. Some cooperating teachers have difficulty in finding adequate time to discuss and evaluate the student teacher's experiences. It is assumed in many instances that the student teacher will observe, listen, and learn by osmosis.

The effective use of MTT's and VTR's does not necessarily make the job of the cooperating teacher easier; it requires him to devote more time to the supervisory process than he would ordinarily. Even when recorders are operated by students, the cooperating teacher still must assume the responsibility of the administration of taping. Most important, however, is the review and analysis of tapes. In some instances in this study, the student teacher was taped but there was no review and analysis of the tape. Due to the shortage of tapes, the cooperating teacher had to erase the recording without viewing it to keep the taping activities on schedule. This is a tremendous waste of time and effort and can cause skepticism toward project activities.

The problem of time is related to the absence of strong incentives for the cooperating teacher. He is assumed to gain status with the assignment of a student teacher who acts as an assistant in several of his classes during the designated period. In addition, he is given a small compensation and free tuition at the University. In view of the amount of time which must be devoted to student teachers, these incentives are not strong enough to stimulate many teachers to assume added responsibilities in supervision by using MTT's and VTR's.

* See discussion on operation of equipment by students, p. 20.

If cooperating teachers are to be involved intensively and effectively in the use of VTR's and MTT's in student teaching, it is essential that they be given adequate time to engage in such activities and more attractive incentives to stimulate them to assume such a responsibility.

The Role of the College Supervisor

The contribution of the college supervisor during the student teaching period is limited. Of his three visits to each assigned school, only one is devoted to analysis and critique of lessons taught by the student teacher. This is by no means adequate and does not reflect the status that student teaching has in teacher education.

In general, all college supervisors who participated in the study reacted enthusiastically to the possibilities inherent in these media and techniques. They agreed to cooperate with the researchers and expressed a desire to include all of their students in any future extension of the procedures followed in this study.

It should be borne in mind, however, that only one of the college supervisors, the co-director, was actively involved in the study and was aware of the range of activities and responsibilities inherent in the use of such media and techniques. In the case of other college supervisors whose students participated in the study, the research staff assumed all responsibility for the technical aspects of taping and organization of student teachers' activities in the laboratory.

If the use of MTT's and VTR's by college professors is to increase the value of the student teaching period, changes in the present system of methods courses and student teaching are required. There is danger of a pseudo-acceptance of these innovations. For example, superficial acquaintance with the media and techniques through a lecture demonstration and a visit to a teaching technique laboratory in which each student teacher is taped once "to have a taste of it" may increase the student teacher's body of knowledge but it is doubtful that it will have an impact on his teaching. What are then the optimum conditions for the introduction of these media and techniques?

The professor must be aware of the shortcomings of the present system of teacher education and student teaching in particular. To effectively use MTT's and VTR's, professors of methods and supervisors of student teachers should participate in special workshops designed to acquaint them with these innovations and the rationale for their introduction.

It is of utmost importance that the college supervisor himself be taped and that he review the tape of his own or, preferably, with the aid of a colleague.

In order to use such media effectively and to convey a feeling of confidence to the students, the college supervisor must have experienced some of the emotions that one may have in self-confrontation. In order to encourage students in analysis and critique, he must himself be open to analysis and critique. A parallel in the self-experience of analysis and therapy often used in the training of psychologists, psychiatrists and counselors and the rationale for such an experience, can be seen in the case of supervisory teachers.

The use of MTT's and VTR's requires the devotion of additional time in student teacher supervision. In the present study, in several instances the professor did not have time to review tapes. In order to take the full advantage of these innovations, excessive time spent by the professor in travel should be reduced. The use of graduate assistants as supervisors and the critique of tapes by telephone conference would also provide the professor with the additional time necessary for utilizing VTR's and MTT's in the supervisory process.

Graduate Assistants as Supervisors

The importance of the student teaching period calls for greater emphasis on the supervisory role assumed by the University professor. However, since there is not a sufficient number of professors to function in this role, it is essential to use graduate assistants as supervisors. They should receive the same preparation which has been suggested for University professors serving as supervisors. It is preferable that they be assigned to student teachers who seem to be secure in the micro-teaching laboratory and appear ready to teach in assigned schools. Students who show more possibility of difficulty in student teaching should be the direct responsibility of the professor.

Tapes of the assistant's supervisory session with the student teacher and the cooperating teacher should from time to time be sent to the college for analysis and critique by the professor with the assistant. This procedure would assure control of the assistant's work and would provide an opportunity for training in supervisory roles.

Supplementing Student Teacher Supervision by Telephone Conferences

Experimentation with supervisory telephone conferences based on tapes sent to the professor was limited due to lack of equipment. However, it seemed to be a worthwhile practice which should be expanded. When equipment is left at schools for long periods and especially when schools purchase their own equipment, it is assumed that many more tapes of student teacher activities, as well as those of the cooperating teacher, will be sent to the professor and critiqued via telephone.

It is essential, however, to reduce the load of the professor during the student teaching period to enable him to engage in an analysis of tapes by telephone conference. Further experimentation with this method is needed to identify the optimal conditions for its use.

The Use of Student Employees and Student Teachers to Transfer Equipment

During the second semester of this study student employees transferred equipment from school to school using University vehicles; they were paid an hourly rate. In several cases, student teachers transported equipment. In both cases, equipment arrived in time and in good working condition.

It is important to increase the involvement of the student teacher by asking him to transfer equipment from his school to another when favorable conditions exist. Equipment should be housed in units which can be carried in sedans. Student teachers should be reimbursed for mileage but should not be paid for transporting equipment.

It should be emphasized to student teachers that taping activities are for their benefit and that they should assume some of the responsibility by transporting equipment. This should not be perceived as an imposition but as a more intensive involvement in activities designed to improve their training. On the other hand, participation in such activities should never conflict with the student teacher's schedule and duties in the school to which he is assigned. It is hypothesized that the student teacher who travels to another school to pick up equipment will use it more than he would if it were delivered to him.

The addition of VTR's and MTT's to a teacher preparation program will obviously increase the operating budget of student teaching. Using student employees and student teachers to transfer equipment will reduce cost.

Taping Activities in Schools

Although cooperating teachers were theoretically in charge of taping of the student teacher, in most cases the student assumed the responsibility of assembling the equipment in the classroom. The student teacher seemed to be better prepared to operate the equipment and was more concerned about it. With the heavy load of the cooperating teacher, he also had more time to engage in preparation for taping activities.

However, some student teachers have indicated that the taping responsibility (assembling equipment and taping, and dismantling) has caused tensions. This was especially true when technical problems developed. The student was not able to

make last-minute preparations for the lesson because he was engaged in technical preparation for taping. The additional responsibility increased his worries during the lesson.

Some student teachers and cooperating teachers have proposed that the College of Education send technicians to assume responsibility for equipment and taping. This, however, will add greatly to the budget of student teaching. It is worthwhile, therefore, to explore the possibility of training a group of high school students to operate the equipment with the supervision of the cooperating teacher. This training should be carried out by a university assistant before the student teaching period. The smooth operation of equipment by high school students will reduce some of the worries of the student teacher and the cooperating teacher.

The Use of Micro-Teaching Techniques in Schools

In addition to the feedback provided by tape, student teachers were asked to distribute, after each lesson they taught the student evaluation form developed and used in the College of Education micro-teaching laboratory. Although this was not done systematically in the fall, during the spring semester each participant kept a cumulative record of his rating by learners in the laboratory; the rating by students in the assigned schools was added to this chart.

The purpose of this practice was primarily to explore the feasibility of obtaining written feedback from regular classroom students. This procedure seemed to be valuable and served to examine the progress of student teachers through rating in the laboratory and schools. Regular classroom students cooperated in filling out evaluation questionnaires, which required approximately five minutes of class time.

CHAPTER IV

VIDEO TAPE RECORDING SYSTEMS. TECHNICAL ASPECTS

The use of media in education is generally considered a means to an end and is viewed as having a secondary role. In this study, however, the media, portable video tape recordings, played a major role in achieving the purposes of the study. The feedback process facilitated by the media was essential not only for the analysis of teaching behavior but also in stimulating teacher awareness and readiness for change. McLuhan's concept that "the medium is the message"^{10/} was apparent in the case of this study.

The success of any study on the use of new media in education depends to a great extent on its proper functioning. This was particularly important in activities designed to modify teaching behavior. Technical difficulties which prevent taping of a highly motivated teacher who is ready to confront himself can cause frustration. Recordings of poor quality and distorted images discourage further participation. Adequate attention must be given therefore to assure the proper functioning of media.

Fears of teachers (especially women) about handling mechanical and electronic equipment act as a deterrent to the intensive use of new media in education. Teachers may be anxious about the use of video recorders which are more expensive than other audio-visual equipment in the school. It should be stated emphatically that the average teacher can set up and operate the video recording equipment successfully after he has received proper training and step-by-step written directions. During the span of the Project reported here, equipment was set up and operated by both men and women. In the case of the student teaching study, 21 participated with the equipment traveling 4,200 miles between 15 schools. The total number of days of usage was 115. The "down time" for the equipment for the entire investigation was only three days at a minimum cost for repairs.

In the following discussion, attention will be given to the technical aspects of the Project's work including the equipment used, a description of the housing units, supplies, maintenance, equipment positioning in the classroom and lab, and camera techniques. The remainder of this chapter will deal with the training of operators, problems arising through misuse of the equipment, and the making of model tapes through the process known as "dubbing."

^{10/} Barrow, Erik. "McLuhanism Reconsidered," Saturday Review, July 23, 1966, p. 19.

Equipment

Each of the two sets of one-half inch tape equipment used in this investigation included the following:

1. Two cameras
2. Two stand-type microphones
3. One lavalier microphone
4. One 9" television monitor
5. One video recorder
6. One amplifier-mixer
7. Two camera tripods
8. Two microphone stands with bases
9. Two sets of cords

Shortly after the Project began, two items were added to improve the quality of the tapes and to be used with either set:

1. One zoom lens
2. One wide-angle lens

Movable Equipment Housings

The original plan called for two identical sets in operation, each housed in the same type of portable unit. Because of the feasibility nature of the Project, however, it was decided that only one of the planned units would be built and it would contain all of the equipment listed above. This unit required the use of a station wagon; therefore, the second housing was planned to be transported in a standard automobile. This smaller unit contained everything the larger one had with the exception of the amplifier-mixer which serves to amplify and control the sound from more than one microphone at a time. A special "Y-tap" was made for the smaller set to allow two or more microphones to be used simultaneously. With the smaller set, therefore, there is no increase in volume other than that provided by the recorder itself, nor is there individual control of the two microphones.

Early in the investigation, a survey of commercial portable units revealed that none were available that would satisfy the requirements determined by the staff. The unit should be

1. self-contained and requiring only a source of 110 volts,
2. compact,
3. capable of being transported by means of a typical car or station wagon,
4. as lightweight as possible,

5. durable,
6. capable of being locked,
7. convenient in use by a standing operator,
8. designed to store equipment and supplies safely in normal highway travel,
9. easily moved when it arrived at a school, and
10. a welcome addition to a classroom or lab in terms of its overall appearance.

As shown in the Appendix, the original unit, called the "Mobile Video Center," incorporates most, if not all, of these specifications. Several things should be noted with regard to this housing:

1. The top half lifts off so that the two halves are slid into a station wagon in their upright position.
2. To prevent rolling on the casters in transit, $\frac{1}{2}$ " steel pins lock the two stationary casters.
3. In transit the two halves are locked together with track catches.
4. The head of one of the camera tripods was removed and mounted in one corner of the unit. It has its full range of elevatability.
5. A single key unlocks all doors.

In the case of the smaller, suitcase-like housing, only the recorder remains outside. When brought to a school, this unit requires some type of convenient-height horizontal surface usually found in a school's projector stand, a bench, or a cafeteria cart.

Essential in the operation of a program involving portable video equipment are two elements. First, well-developed operating instructions must accompany the equipment and must be used faithfully. The present versions found in the Appendix are the result of many revisions and have proven to be near-foolproof when used by anyone who is not colorblind. This leads into the second element, namely, that all wire connecting done by the operator is simply a matter of following color coding of the parts to be joined. The original video tape equipment is not color coded but it is easy and very time-and-trouble saving to use colors to direct the operator.

Supplies

Supplies for the successful operating of the equipment are minimal except for the first item below:

1. Video tapes.
2. Head cleaning fluid.
3. Splicing tape.

As to the price of video tapes, a standard $\frac{1}{2}$ " tape costs approximately \$40 and will provide roughly 55 minutes of playing time. In any new taping the previous recorded image is automatically erased and can be used countless times with a life expectancy, according to one manufacturer, of seven to ten years.

The head cleaning fluid and splicing tape (similar to the short pieces used with audio tapes) are provided in a small carton as part of the set.

Maintenance

Common maintenance of the equipment is relatively simple and can be performed by anyone who has a copy of the manufacturer's manual. Persons responsible for the equipment should be well acquainted with the directions in the manual and act accordingly.

There is, of course, at times, the need for the services of a trained technician in matters of adjustment and even repair if a component is damaged. If such a person is not available, the set must be returned to the manufacturer or his service representative.

Regarding cleaning of the head, the necessary materials are found in the supplies provided by the manufacturer. The manual indicates the proper procedure.

Camera lenses should be cleaned occasionally with readily-available lens tissue.

Guidelines for Setting Up and Operating Equipment in the School

There are many possibilities for the locating of equipment in the classroom or laboratory depending on such factors as the size of the class, the number of cameras and microphones to be used and external conditions such as distracting noises and strong natural light.

Ideally, the taping procedure should not influence the learning environment in any way. To help in achieving this, some guidelines have been developed by the Project staff regarding the locating and operating of equipment.

1. Positioning of Cameras. The center of the video taping operation (where the recorder, monitor, and No. 1 camera are located), should be typically in the back of the classroom at one side. This camera is used chiefly to pick up the instructor although it can be rotated to record student reactions also. Its effectiveness is increased if a zoom lens is mounted on it. If there is intensive light coming through windows, the center should be located on the window side. If windows are no problem (as discovered in a trial setup), positioning the camera on the students' right side away from the windows provides better pick-up of most right-handed instructors at the chalkboard.

In Project activities, the No. 2 camera, without an operator, was usually placed in a front corner of the classroom to record the students. With a typical class, the wide-angle lens improved the coverage resulting, of course, in a smaller picture of each student. A switch on the recorder that is controlled by the operator determines which camera is being recorded on the tape.

2. Positioning of Microphones. The use of two or three microphones is recommended to provide adequate sound recording. Stand microphones used in the Project were not directional so one was usually placed in the first or second row of students and aimed at the rear of the group. This microphone plus the lavalier microphone used by the instructor provided relatively satisfactory sound pick-up in the typical situation. Three microphones were used with the Mobile Video Center under more difficult circumstances. It was found that placing a microphone close to students can cause a distraction in some classes.

Recording the audio part of interaction between students and teachers in regular classroom conditions has always been and remains a difficult problem. The instructor who knows how to project his voice has a lavalier microphone which picks up his comments very well. The real problem is in recording the student responses with just two microphones especially when some students fail to project well. There is even greater difficulty with adverse acoustical conditions. More sensitive microphones are being developed constantly and their possibilities should be explored for improved pick-up of student-teacher interaction.

3. Classroom Arrangement. In a classroom situation, chairs can sometimes be arranged to avoid students blocking out other students. To obtain better quality in the taping of chalkboard work, it is important to have as clean a board as is possible. Soft chalk (preferably yellow) is recommended.

Taping of a demonstration at a piece of equipment such as a milling machine can be difficult because of the tendency of students to crowd in. One method that may help would be to keep a clear view of the instructor by moving in a few chairs or some low objects between him and the camera. Another possible solution would be to

place the camera tripod on a nearby bench for a high angle shot (with a zoom lens for better pick-up) if this is not too distracting to the students.

4. Camera technique. Good camera technique includes
 - a. keeping the focal point "on camera,"
 - b. smooth, slow movement except in unusual circumstances,
 - c. allowing the picture enough time to be understood by the viewer,
 - d. anticipating what is coming up so that it is accurately recorded (as in the case of a student with a question),
 - e. skilled use of the zoom lens, and
 - f. stopping down the lens (increasing the "contrast") for better chalkboard taping.

Problems Due to Improper Use of Equipment

Basically, the few technical difficulties encountered with the equipment after the housing units were built were caused by operators who failed to follow the instructions. In one case, a camera was tipped over by a high school student who accidentally caught his foot on a poorly placed cable. In another instance, an electronics teacher tried to repair the equipment and soldered a loose wire to the wrong terminal resulting in a direct short. A recorder was also damaged by the operator who moved the "Play-Stop-Rewind" lever from "Rewind" directly to "Play" without letting the machine come to a complete stop. This resulted in the jamming of the machine when the tape became entangled in the revolving portion known as the "head." These three mishaps were the only ones of any significance that developed during the operation of the Project.

Factors to Consider Before Purchasing Equipment

In considering the purchase of nonprofessional portable video recorders one can choose either a one-half-inch or a one-inch machine. The experience of the project staff in this study and in a similar study conducted in the University of Illinois College of Engineering leads to the conclusion that recent models of half-inch equipment are very adequate in their performance.

Not only did this size serve well in the everyday taping and reviewing but also proved very effective in dubbing procedures and as the source of feeding 24-inch monitors. The latter was done in several presentations to groups of 50 to 100 people.

The cost of a video taping set of equipment can vary considerably depending on size, the type of equipment, and the accessories needed. The simplest combination, which includes one camera, one microphone and one amplifier-mixer,

would list at approximately \$1,200. The price of each set used in project activities was roughly \$2,800. This did not include the zoom lens for \$350, nor the wide-angle lens at \$75.

In addition to these special lenses, which were found to be very helpful, the equipment buyer should give consideration to a set of accessories which would allow the instructor and a student or group of students to be picked up from two cameras simultaneously. This is known as "split-screen operation" and requires an additional investment of approximately \$1,200 for a sync generator and special effects generator. Just as the split screen used in televising sports events proves valuable, it would appear that it would have value in classroom taping especially when the major concern is feedback through nonverbal clues or student reactions to the instructor's activities.

One of the factors to consider before purchasing equipment is its compatibility (i.e., the ability to play back tapes recorded on two different machines made by one company). All manufacturers claim that their equipment is compatible; however, there is a great deal of difference between advertising and actual performance. Few, if any, half-inch VTR's have 100 percent compatibility. The wider the tape, the more the likelihood of compatibility. Regarding this point it should be mentioned that a qualified technician can adjust several sets to make them more compatible. In the case of the project's activities, this was done and the results were very acceptable.

With the value of video taping equipment in teacher education becoming more and more apparent, manufacturers have greatly increased production. They are still unable to satisfy the demand, however, particularly when immediate delivery is requested.

Training School Personnel in Technical Aspects

The importance of training student teachers and cooperating teachers in the operation of video recording systems should be emphasized. For most teachers and student teachers this should be included as part of their training in the use of other audio-visual aids. In addition to instruction in setting up and operating the equipment by actually working with it, they should be given problems to challenge their ability to arrange the equipment for typical, and some atypical, situations, such as a demonstration at a machine or a lecture in which small objects are introduced to the class.

This type of instruction for student teachers can best be conducted in the methods course along with the orientation to micro-teaching and to the project. At the University of Illinois, the student's experiences in the

Teaching Techniques Laboratory do not include instruction in the operating of equipment.

In the case of a few student teachers, particularly those in industrial education, this orientation may be the start of an intensive interest in video taping equipment and should be encouraged.

It is recommended that cooperating teachers in the student teaching program be required to attend a project orientation workshop, part of which would include instruction in the operating of equipment.

For participants in in-service educational programs, a similar orientation should be conducted; however, this should be done at the school rather than the university.

Preparation of Model Tapes

In any video taping operation there is a greater amount of latitude and flexibility if selected portions from various tapes can be combined on one tape. This is particularly true in the case of the preparation of "model tapes" which are instructional tapes designed to show exemplary performance in a classroom.

Although it is true that tapes can be spliced, this often is a poor solution to the problem for two reasons. First, the mechanical fusing of two or more tapes is not as dependable as a single tape without any breaks. Secondly, the original tapes are no longer intact and complete, thus, their further use is limited.

A better procedure for making model tapes is the system known in the field as "dubbing" or the preparation of a new recording from several other tapes with no change in the original tapes. In this process the recorder on which the dubbing is done must be compatible with the machines used in making the original tapes. In view of the fact that even some video tape technicians doubt that dubbing of half-inch tape can be done, a method developed by the project's staff member responsible for the equipment is presented in the Appendix.

In the developing of model tapes, captioning to identify the various parts of a tape can be very effective. For the model tapes made by the project staff, captions were made simply by video taping the titles made up of self-adhesive white ceramic letters fastened to the dark surface on the back of the Mobile Video Center.

Viewers of television news broadcasts are familiar with a "voice override" even though they may not be aware of the accepted term for this technique. When the volume of a tape recording of a news story is lowered and the news reporter

comments at the normal level of sound, this is known as a "voice override."
This method can be used effectively in the preparation of model tapes when
the procedures found in the Appendix are followed.

CHAPTER V

CONCLUSIONS AND RECOMMENDATIONS

The order in which the following conclusions and recommendations are presented is no indication of their relative importance.

The Teaching Methods Course and the Teaching Techniques Laboratory (TTL)

All participants have indicated the positive contribution and great potential of the TTL in the training of student teachers. However, they felt that more intensive activities and greater coordination with the teaching methods courses would have been more beneficial. Similar impressions were expressed by professors in other departments in the College of Education. There is also ample evidence in the literature citing similar reactions from other universities utilizing these media and techniques.

Since this was the first year of operation for the TTL, emphasis was put on the orientation of students to this innovation. There was not enough time to structure the fusion of the TTL experiences with the vocational-technical education teaching methods courses, which is essential in order to realize the maximum benefits of the TTL. This may require changing several aspects of the existing patterns in teaching methods courses and putting greater emphasis on the acquisition of teaching skills and the ability to utilize feedback mechanisms effectively.

RECOMMENDATION 1. The Department of Vocational and Technical Education should consider the possibility of requiring a students to participate in an intensive, structured program in the TTL before student teaching. These activities should be fused with teaching methods courses. Greater emphasis should be given in these courses to the analysis of classroom interaction and the acquisition of specific teaching skills.

The Teaching Methods Professor

College professors cooperating in this study were acquainted with these media and techniques in a brief faculty workshop. Further acquaintance was achieved through examination of the literature and participation in conventions.

There is a growing body of knowledge on micro-teaching and feedback mechanisms, some of which was disseminated to teacher educators in a series of national seminars on "Innovations in Teacher Education." Some universities conduct worksnops for their education faculties on these subjects.

To achieve effective utilization of these media and techniques in methods courses and TTL, the teaching methods professor should have the opportunity to

become acquainted with the literature in this area, to share the experiences of other teacher educators with the media and techniques, and to be involved in TTL experiences.

RECOMMENDATION 2. Faculty members who teach methods courses and supervise student teachers should have opportunities to become better acquainted with video recording systems, micro-teaching, and related areas. This could be achieved through a systematic dissemination of literature on the subject by the TTL and the researchers. The Department should encourage participation in local and national workshops and provide financial aid for such activities.

The Cooperating Teacher

The cooperating teacher assumes the major role of guiding the student teacher in the first teaching experience. It is doubtful that many of them can fulfill this important function without adequate preparation. In the present system, there is no formal intensive training of cooperating teachers, nor do they have suitable conditions to serve in this role.

The use of micro-teaching techniques and video recordings aid the cooperating teacher; however, they require him to devote more time and put more energy into the guiding of the student teacher.

RECOMMENDATION 3. The effective use of video recordings and micro-teaching techniques by the cooperating teacher requires intensive training for this purpose. He should be given adequate time, technical help, and other incentives to carry out this work.

Self-Appraisal by Student Teachers

Student teachers participating in the study did not use video recordings to their full potential as feedback mechanisms for self-appraisal. Various reasons account for this: equipment was available in the schools only for short periods; student teachers were heavily loaded with assignments and did not have time to experiment with taping and self-analysis. One of the main problems, however, seemed to be the anxiety of self-confrontation.

Teacher education is a never-ending process; preservice training is only the first part of this process. The importance of engaging in activities of self-appraisal should be stressed during this period. Moreover, student teachers should acquire skills and techniques to pursue such activities individually. When introducing this media and techniques to students, its long-range utilization for better self-understanding and self-improvement during the teaching career should be emphasized.

RECOMMENDATION 4. Greater emphasis should be placed on the self-appraisal and self-understanding process during the methods courses and TTL experiences. Student teachers should be encouraged to practice self-taping and analysis in schools. Each student teacher should prepare a video tape recording of some of his lessons and include a written self-appraisal of the recorded teaching experiences.

The Use of VTR's During the College Supervisor's Visits

During the study, the college supervisors used video tape recordings to analyze the student teacher's activities. Some of these recordings were made during the supervisor's visit to the school while others were taped before his arrival. The limited time of the college supervisor in the school was typically spent discussing the various problems of student teaching and did not allow adequate time for review of tapes and analysis of specific teaching skills.

If student teachers receive intensive practice in teaching skills during their methods courses and TTL experiences, it is possible that some of them might teach a short lesson during the later part of their first week in school. It is desirable that this lesson be taped and every effort be made to permit an analysis of the tape during the supervisor's first visit. The last visit, which is used in many instances for an evaluation discussion with the cooperating teacher, should also include an analysis of tapes.

RECOMMENDATION 5. In view of the limited number of the college supervisor's visits in the schools, it is desirable that each visit include a discussion based on tapes recorded before or during the supervisor's visit. It is highly recommended that the cooperating teacher participate in each analysis session. It is recommended that the college supervisor spend more than the regular three half-day visits with each student teacher.

Analysis of Tapes and Critique Via Telephone

Experiences in this study indicated that the mailing of tapes to the professor for analysis and the critiquing of these tapes via telephone provides an important augmentation to the supervisor's visits. Several conditions are required to achieve greater effectiveness in this technique.

The period between the taping in the classroom and the analysis by telephone should be as short as possible. The professor must have adequate time to analyze the tapes. In the optimal situation, there would be two sets of equipment which would provide a preconference analysis of tapes, and simultaneous viewing. If only one set is available, it is desirable that a

regular audio recording be prepared in addition to the video tape. The student teacher and the cooperating teacher could prepare themselves by listening to this recording before the telephone conference.

RECOMMENDATION 6. The telephone conference is an important augmentation to present critiquing procedures. It is recommended that greater emphasis be placed on development of this method of student teaching supervision.

Graduate Assistants as Student Teacher Supervisors

RECOMMENDATION 7. In view of the limited time available to university professors to supervise student teachers in the field, the increased use of graduate assistants as supervisors is seen as a necessary step. These assistants should be trained in the use of VTR's and MTT's in the supervision of student teachers.

The Use of Student Teachers and University Student Employees to Transfer Equipment

The use of students teachers in transferring equipment should be viewed as part of their involvement in an activity designed to improve their teaching skills. This will also reduce the added cost resulting from the addition of these activities to student teaching.

RECOMMENDATION 8. It is essential that equipment be housed in units which can be transferred in standard automobiles so that student teachers and university student employees can transfer them in their own cars. It is recommended that student teachers and university student employees be involved in transferring equipment to schools. Such activities should never conflict with the duties of student teachers in their schools.

Taping Activities in the Schools

Most student teachers in this study assumed responsibility for preparing and supervising the operation of equipment while they were taped. This added duty increased their burdens and anxieties.

RECOMMENDATION 9. Student teachers should be relieved of the duty of assembling equipment and supervising the taping of their own lessons. The cooperating teacher should assume the responsibility of setting up and operating equipment and should be assisted by trained high school students.

The Use of Micro-Teaching Techniques in Schools

RECOMMENDATION 10. It is recommended that experimentation with MTT's in the schools with regular classroom students be expanded. The practice of obtaining written feedback from regular classroom students and the establishment of a micro "laboratory," using volunteers or paid students, should be explored.

Custom-Built Housings for Equipment

The success of a program that relies heavily on feedback, through new media, depends, in part, on the reliability of these technical and electronic devices. When the equipment must be transported between schools, additional problems arise. There are few, if any, housing units on the market designed for transporting equipment. At the present time the answer lies in the custom-built unit. However, if a school is purchasing its own equipment, commercial housing units are available. Such units provide easy mobility between classrooms, reduce time required for setup and serve to store all electronic components safely.

RECOMMENDATION 11. To safely transport equipment and for its efficient use in the schools, it is essential that well-designed, housing units be provided (custom-built or commercially available). Illustrated instructions should accompany each unit. (They must be followed faithfully) Color coding of electrical connections should be done to assist the operator.

The Selection of Equipment

Experiences in this Project indicate that for the type of work carried on in this investigation, one-half-inch video tape recorders are adequate in spite of their small size which adds to their portability. This decision is based on the findings that (1) trained operators can produce $\frac{1}{2}$ " tapes of good quality and (2) that half-inch video tape recorders are capable of producing dubbed tapes with captions and voice override. They can be used to project a tape on a 24" monitor for larger groups. Since two $\frac{1}{2}$ " tape sets can be purchased for the price of one larger set, equipment could have twice the use.

RECOMMENDATION 12. Because of performance, size, weight, and cost, the half-inch size of VTR should be given serious consideration by anyone contemplating the purchase of equipment for video taping of student teachers in the field. This size should also serve very well in methods class activities.

Equipment Scheduling

RECOMMENDATION 13. A well-planned schedule for the transporting of equipment should be completed far in advance. Such a schedule should route the units to the equipment center for the weekends to permit adjustment and maintenance.

BIBLIOGRAPHY

- Alexander, L.T., Kepner, C.H., and Tregoe, B.B. "The Effectiveness of Knowledge of Results in a Military System Training Program," Journal of Applied Psychology, Vol. 46, No. 3, June, 1962, pp. 202-211.
- Alexander, L.T. and others. A Demonstration of the Use of Simulation in the Training of School Administrators. New York: Office of Research and Evaluation, Division of Teacher Education, City University of New York, 1967.
- Allen, D.W. "A New Design for Teacher Education: The Teacher Intern Program At Stanford University," Journal of Teacher Education, Vol. 17, No. 3, 1966, pp. 296-300.
- Allen, D.W. Micro-Teaching: A Description. Stanford, California: Stanford University, School of Education, 1966.
- Allen, D.W. "Micro-Teaching: A New Framework for In-service Education," High School Journal, Vol. 49, May, 1966, pp. 355-362.
- Allen, D.W. "New Dimensions in Trade and Technical Teacher Education," American Vocational Teacher Journal, Vol. 41, September, 1966, pp. 20-22.
- Allen, D.W. and others. A Comparison of Different Modeling Procedures in the Acquisition of a Teaching Skill. Stanford University. Unpublished paper presented at the American Educational Research Association Convention, Chicago, February, 1968.
- Allen, D.W. and Fortune, F.C. An Analysis of Micro-Teaching: A New Procedure in Teacher Education. Unpublished paper presented at the American Educational Research Association Convention, Chicago, February, 1965.
- Allen, D.W. and Gross, R.E. "Micro-Teaching - A New Beginning for Beginners," NEA Journal, Vol. 55, No. 9, December, 1965, pp. 25-26.
- Allen, D.W. and Ryan, K.A. A New Face for Supervision. Unpublished paper prepared for use in the 1965-1966 Regional TEPS Conference.
- Allen, D.W. and Young, D. Television Recordings - A New Dimension in Teacher Education. Stanford University. Unpublished mimeographed paper.
- Amidon, E.J. "Interaction Analysis and Its Application to Student Teaching," Theoretical Bases for Professional Laboratory Experiences in Teacher Education. Forty-fourth Yearbook. Cedar Falls, Iowa: Association for Student Teaching, 1965.
- Amidon, E.J. Using Interaction Analysis at Temple University. Paper read at the Conference on the Implications of Recent Research on Teaching for Teacher Education, sponsored by the National Association for Student Teaching and the University of Rochester, Rochester, New York, January, 1966.
- Amidon, E.J. and Amidon, P. Interaction Analysis Training Kit: Level I. Minneapolis: Association for Productive Teaching, 1967.

- Amidon, E.J. and Amidon, P. Interaction Analysis Training Kit: Level II. Minneapolis: Association for Productive Teaching, 1967.
- Amidon, E.J. and Amidon, P. Teaching Pattern Analysis. Minneapolis: Association for Productive Teaching, 1967.
- Amidon, E.J. and Flanders, N. "Interaction Analysis as a Feedback System," Interaction Analysis: Research, Theory and Application. E.J. Amidon and J.B. Hough (eds.). Boston: Addison-Wesley, 1967, pp. 121-140.
- Amidon, E.J. and Flanders, N. The Role of the Teacher in the Classroom: A Manual for Understanding and Improving Teachers' Classroom Behavior. Minneapolis: Paul S. Amidon Associates, 1967.
- Amidon, E.J. and Giammatteo, M.C. "The Behavior of Superior Teachers," The Elementary School Journal, Vol. 65, February, 1965, pp. 283-285.
- Amidon, E.J. and Hough, J.B. (eds.) Interaction Analysis: Research, Theory and Application. Boston: Addison-Wesley, 1967.
- Amidon, E.J. and Hunter, E. Improving Teaching: Analyzing Verbal Interaction in the Classroom. New York: Holt, Rinehart, and Winston, 1966.
- Amidon, E.J. and Hunter, E. Improving Teaching: The Analysis of Classroom Instruction. New York: Holt, Rinehart, and Winston, 1966.
- Amidon, E.J. and Hunter, E. "Interaction Analysis: Recent Developments," Interaction Analysis: Research, Theory and Application. E.J. Amidon and J.B. Hough (eds.). Boston: Addison-Wesley, 1967, pp. 388-392.
- Amidon, E.J. and Hunter, E. "Verbal Interaction in the Classroom," Professional Reprints in Education, No. 8605. Columbus, Ohio: Charles E. Merrill Books, 1966.
- Amidon, E.J., Kies, K., and Palisi, A. "A Fresh Look at Supervision," The National Elementary Principal, Vol. 45, April, 1966, pp. 54-59.
- Amidon, E.J., and Powell, E.R. Interaction Analysis as a Feedback System in Teacher Preparation. Paper read at the Association for Supervision and Curriculum Development, Curriculum Research Institute, Washington, D.C., November, 1965.
- Amidon, E.J. and Rosenshine, B. Interaction Analysis and Microteaching in an Urban Teacher Education Program - A Model for Skill Development in Teaching. Temple University. Unpublished paper presented at the American Educational Research Association Convention, Chicago, February, 1968.
- Amidon, E.J. and Simon, A. Implications for Teacher Education of Interaction Analysis Research in Student Teaching. Paper read as part of a symposium on interaction analysis and its application to student teaching, American Educational Research Association Convention, Chicago, February, 1965.
- Amidon, E.J. and Simon, A. "Teacher-Pupil Interaction," Review of Educational Research, Vol. 35, April, 1965, pp. 130-139.

- Amidon, E.J., Weber, W.A. and Powell, E.R. Integration of the Dimensions of a Number of Category Systems into a Single-Category System: An Application to Children in Deprived Schools. Temple University, Syracuse University, University of Georgia. Unpublished paper presented at the American Educational Research Association Convention, Chicago, February, 1968.
- Amidon, E.J. and others. "Interaction Analysis and Its Application to Student Teaching," Association for Student Teaching Yearbook. Dubuque, Iowa: William C. Brown Co., 1965.
- Amidon, E.J. and others. Project on Student Teaching: The Effects of Teaching Interaction Analysis to Student Teachers. United States Department of Health, Education, and Welfare, Office of Education, Cooperative Research Project No. 2873. Philadelphia: Temple University, 1967.
- Andrews, L.O. A Curriculum to Produce Career Teachers for the 1980's. Ohio State University. Unpublished mimeographed paper, 1967.
- Aubertine, H.E. The Use of Micro-Teaching in the Process of Training Clinical Supervisors. Arizona State University. Unpublished mimeographed paper presented at the American Educational Research Association Convention, Chicago, February, 1967.
- Baird, J.H., Belt, W.D., and Webb, C.D. Micro-Teaching at Brigham Young University. Brigham Young University, School of Education. Unpublished mimeographed paper.
- Barnow, Erik. "McLuhanism Reconsidered," Saturday Review, Vol. 49, No. 30, July 23, 1966, pp. 19-23.
- Bellack, A. and others. The Language of the Classroom. New York: Bureau of Publications, Teachers College, Columbia University, 1967.
- Belt, W.D. and Holder, L.E. Continuous Progress in the Training of Secondary Teachers at B.Y.U.: Content and Rationale. Brigham Young University. Unpublished paper presented at the American Educational Research Association Convention, Chicago, February, 1968.
- Belt, W.D. and Webb, C.D. "Micro-Teaching at Brigham Young University," Utah Educational Review, Vol. 61, No. 1, September-October, 1967, p. 18.
- Binnington, G.H. Self-Acceptance Changes in Student Teachers as a Result of Student-Centered University Supervision. University of Oregon, Eugene. Unpublished doctoral dissertation, 1965.
- Bloom, B.S. "The Thought Process of Students in Discussion," Accent on Teaching: Experiments in General Education. S.J. French (ed.). New York: Harper and Brothers, 1954.
- Borg, W.R. The Minicourse: Rationale and Uses in the Inservice Education of Teachers. Unpublished paper presented at the American Educational Research Association Convention, Chicago, February, 1968.
- Bridle, B.J. "The Integration of Teacher Effectiveness Research," Contemporary Research on Teacher Effectiveness. New York: Holt, Rinehart, and Winston, 1964, pp. 1-40.

- Brown, A.B., Coban, M.E., and Waterman, F.T. An Analysis of Verbal Teaching Behavior, An Approach to Supervisory Conferences with Student Teachers. Teachers College, Columbia University. Unpublished doctoral dissertation, 1965.
- Bush, R.N. and Allen, D.W. Micro-Teaching - Controlled Practice in the Training of Teachers. Unpublished paper presented at the Santa Barbara Conference on Teacher Education of the Ford Foundation, 1964.
- Coffey, H.S. and Golden, W.P., Jr. "Psychology of Change Within an Institution," In-Service Education for Teachers, Supervisors, and Administrators. N.B. Henry (ed.). The Fifty-sixth Yearbook of the National Society for the Study of Education. Chicago: The University of Chicago Press, 1957, p. 67.
- Conant, J.B. The Education of American Teachers. New York: McGraw-Hill, 1963.
- Cooper, J.M. Developing Specific Teaching Skills Through Micro-Teaching. Stanford University. Unpublished paper.
- Corey, S.M. "Introduction," In-Service Education for Teachers, Supervisors, and Administrators. N.B. Henry (ed.). The Fifty-sixth Yearbook of the National Society for the Study of Education. Chicago: The University of Chicago Press, 1957, pp. 2-3.
- Dalton, R.E. A Comparative Appraisal of Supervising Teacher and Student Teacher Performance as an Evaluation Technique in Student Teaching Programs. Purdue University. Unpublished doctoral dissertation, 1965.
- Daniels, L. Teacher Perceptions on the Role of a Teacher. University of California, Los Angeles. Unpublished master's thesis, 1964.
- Drumheller, S.J. and Paris, J. "An Effective Approach for Incorporating Teaching Experiences in Methods Courses," Journal of Teacher Education, Vol. 18, No. 3, 1966, pp. 290-295.
- Elliott, R.J. Changes in Openness of Student Teachers as a Function of Openness of Supervising and Cooperating Teachers. University of Alabama. Unpublished doctoral dissertation, 1965.
- Flanders, N.A. "Intent, Action, and Feedback: A Preparation for Teaching," Interaction Analysis: Research, Theory and Application. E.J. Amidon and J.B. Hough (eds.). Boston: Addison-Wesley, 1967, pp. 283-294.
- Flanders, N.A. "The Problems of Observer Training and Reliability," Interaction Analysis: Research, Theory and Application. E.J. Amidon and J.B. Hough (eds.). Boston: Addison-Wesley, 1967, pp. 158-166.
- Flanders, N.A. "Some Relationships Among Teacher Influence, Pupil Attitudes," Interaction Analysis: Research, Theory and Application. E.J. Amidon and J.B. Hough (eds.). Boston: Addison-Wesley, 1967, pp. 217-242.
- Flanders, N.A. "Teacher Behavior and In-Service Programs," Interaction Analysis: Research, Theory and Application. E.J. Amidon and J.B. Hough (eds.). Boston: Addison-Wesley, 1967, pp. 256-261.
- Fortune, J.C., Cooper, J.M., and Allen, D.W. The Stanford Summer Micro-Teaching Clinic, 1965. Stanford University. Unpublished paper, 1965.

- Foster, F.G. "Micro-Teaching," Arizona Teacher, Vol. 55, May, 1967, pp. 12-13.
- Friedman, N.L. "Instant Playback in the Shop," Industrial Arts and Vocational Education, Vol. 57, January, 1968, pp. 34-35.
- Furst, N. The Effects of Training in Interaction Analysis on the Behavior of Student Teachers in Secondary Schools. Paper read at the American Educational Research Association Convention, Chicago, February, 1965.
- Furst, N. and Amidon, E.J. Teacher-Pupil Interaction Patterns in the Elementary School. Paper read at Schoolmen's Week, University of Pennsylvania, Philadelphia, 1962.
- Gallagher, J. and others. A System of Topic Classification Classroom Interaction Study. Institute for Research on Exceptional Children, University of Illinois. Mimeographed paper, 1966.
- Gallagher, J. A Topic Classification System for Interaction Analysis. United States Office of Education. Unpublished paper presented at the American Educational Research Association Convention, Chicago, February, 1968.
- Goodkind, T.B. An Evaluation of the Effectiveness of the Micro-Teaching Technique in the Training of Elementary School Teachers. University of Connecticut. Unpublished paper presented at the American Educational Research Association Convention, Chicago, February, 1968.
- Hill, R.A. Systems Analysis of Teaching: An R & D Model. Temple University. Unpublished paper presented at the American Educational Research Association Convention, Chicago, February, 1968.
- Hill, R.A. and Medley, D.M. Change in Behaviors of First Year Intern Teachers. Temple University, Educational Testing Services. Unpublished paper presented at the American Educational Research Association Convention, Chicago, February, 1968.
- Honigman, F.K. A Three-Dimensional System for Analyzing Teacher-Pupil Interaction in the Classroom. Franklin Institute. Unpublished paper presented at the American Educational Research Association Convention, Chicago, February, 1968.
- Honigman, F.K. Innovations and Revisions to the Flanders System of Interaction Analysis. Temple University. Mimeographed paper, 1964.
- Honigman, F.K. Multidimensional Analysis of Classroom Interaction (MACI). Villanova, Pennsylvania: The Villanova University Press, 1967.
- Hough, J.B. "Classroom Interaction and the Facilitation of Learning: The Source of Instructional Theory," Interaction Analysis: Research, Theory and Application. E.J. Amidon and J.B. Hough (eds.). Boston: Addison-Wesley, 1967, pp. 375-387.
- Hough, J.B. "An Observation System for the Analysis of Classroom Instruction," Interaction Analysis: Research, Theory and Application. E.J. Amidon and J.B. Hough (eds.). Boston: Addison-Wesley, 1967, pp. 150-157.

- Hough, J.B. A Study of the Effect of Five Experimental Treatments on the Development of Human Relations Skills and Verbal Teaching Behaviors of Pre-Service Teachers. College of Education, Ohio State University. Unpublished paper, 1965.
- Hough, J.B. The Dogmatism Factor in Human Relations Training of Preservice Teachers. Unpublished paper presented at the American Educational Research Association Convention, Chicago, February, 1965.
- Hough, J.P. and Amidon, E.J. Behavioral Change in Pre-Service Teacher Preparation: An Experimental Study. Philadelphia: College of Education, Temple University, 1964.
- Hough, J.B. and Amidon, E.J. "Behavioral Change in Student Teachers," Interaction Analysis: Research, Theory and Application. E.J. Amidon and J.B. Hough (eds.). Boston: Addison-Wesley, 1967, pp. 307-314.
- Hough, J.B. and Ober, P. The Effect of Training in Interaction Analysis on the Verbal Training Behavior of Pre-Service Teachers. Paper presented at the American Educational Research Association Convention, Chicago, February, 1966.
- Howsam, R.B. New Designs for Research in Teacher Education. California Teachers' Association, 1960.
- Hunter, E. and Amidon, E.J. "Direct Experience in Teacher Education: Innovation and Experimentation," Journal of Teacher Education, Vol. 17, No. 3, Fall, 1966, pp. 282-289.
- Jalbert, E.L. An Investigation to Determine the Effectiveness of Training in the Evaluation of Classroom Instruction as an Aid to Self-Evaluation in Student-Teaching. Syracuse University. Unpublished doctoral dissertation, 1965.
- Joyce, B., Weinstein, G., and Hunt, D. Four-Dimensional Analysis of Teaching. Unpublished paper, 1966.
- Kagan, N., Krathwohl, D., and Farquhar, W. IPR - Interpersonal Process Recall: Stimulated Recall by Videotape. East Lansing, Michigan: Michigan State University, College of Education, Bureau of Education Research Services, Series No. 24, March, 1965.
- Kallenbach, W.W. The Effectiveness of Microteaching in the Preparation of Elementary Intern Teachers. Far West Laboratory for Educational Research and Development. Unpublished paper presented at the American Educational Research Association Convention, Chicago, February, 1968.
- Kallenbach, W.W. "Microteaching as a Teaching Methodology," Proceedings: Conference on Instructional Methods and Teacher Behavior. Berkeley: Far West Laboratory for Educational Research and Development, 1968, pp. 14-19.
- Kersh, B.Y. Classroom Simulation: Further Studies on Dimensions of Realism. Unpublished paper presented at the American Educational Research Association Convention, Chicago, February, 1966.

- Kirk, J. "Elementary School Student Teachers and Interaction Analysis," Interaction Analysis: Research, Theory and Application. E.J. Amidon and J.B. Hough (eds.). Boston: Addison-Wesley, 1967, pp. 299-306.
- Kirk, J. The Effects of Teaching the Minnesota System of Interaction Analysis on the Behavior of Student Teachers. Temple University. Unpublished doctoral dissertation, 1964.
- LaGrone, H.F. A Proposal for the Revision of the Preservice Professional Component of a Program of Teacher Education. Washington, D.C.: The American Association of Colleges for Teacher Education, 1964.
- LaShier, W.S., Jr. The Use of Interaction Analysis in BSCS Laboratory Block Classrooms. Paper read at the National Science Teachers Association Meetings, New York City, April, 1966.
- Lewin, K. "Conduct Knowledge and Acceptance of New Values," Resolving Social Conflicts. New York: Harper and Brothers, 1948.
- Lewin, K. and Grabbe, P. "Problems in Re-education," Journal of Social Issues, Vol. 1, No. 3, August, 1965, pp. 53-64.
- Maccoby, N. and others. Sound Film Recordings in Improving Classroom Communication. A report submitted to the United States Office of Education, Title VII, Project 680. Stanford, California: Institute for Communication Research, Stanford University, 1965.
- Maier, N.R.F. Problem Solving Discussions and Conferences: Leadership Methods and Skills. New York: McGraw-Hill, 1963.
- Medley, D.M. and Hill, R.A. A Comparison of Two Techniques for Analyzing Classroom Behavior. Educational Testing Service, Temple University. Unpublished paper presented at the American Educational Research Association Convention, Chicago, February, 1968.
- Medley, D.M. and Mitzel, H.E. "Measuring Classroom Behavior By Systematic Observation," Handbook of Research on Teaching. N.L. Gage (ed.). Chicago: Rand McNally & Co., 1963, pp. 247-328.
- Meier, J.H. Micro-Counseling - An Interpersonal Sensitization Experience. Psycho-Educational Research Institute. Unpublished paper, 1966.
- Meier, J.H. Microteaching in Small School In-Service Education Programs. Rocky Mountain Regional Education Laboratory. Unpublished paper presented at the American Educational Research Association Convention, Chicago, February, 1968.
- Meier, J.H. NDEA Remote Teacher Training Program in Early Childhood Education. Greeley, Colorado: Child Study Institute, Colorado State College, 1967.
- Meier, J.H. Rationale for and Application of Microteaching to Improve Teaching. Rocky Mountain Regional Education Laboratory. Mimeographed paper, 1968.

- Meier, J.H. and Brudenell, G. Simulated Lesson Analysis Chart (SimuLAC). Greeley, Colorado: NDEA Microteaching Program, Child Study Institute, Colorado State College, 1967.
- Meier, J.H. and Brudenell, G. Interim Progress Report of a Remote Teacher Training Institute for Early Childhood Educators. Child Study Institute, Colorado State College. Unpublished paper presented at the American Educational Research Association Convention, Chicago, February, 1968.
- Merrill, M.D. Training Teachers for Instructional Design - A Problem and A Point of View. Stanford University. Unpublished paper presented at the American Educational Research Association Convention, Chicago, February, 1968.
- Miel, A. Changing the Curriculum - A Social Process New York: Appleton-Century-Crofts, Inc., 1946.
- Miller, G.L. An Investigation of Teaching Behavior and Pupil Thinking. Salt Lake City: Utah State Board of Education Research and Experimentation Funds Section, Agreement Number 4622, 1964.
- Minnis, D. Interaction Analysis and Microteaching Procedures in In-Service Education of Teachers. University of California, Davis. Unpublished paper presented at the American Educational Research Association Convention, Chicago, February, 1968.
- Minnis, D. Micro-Teaching and Interaction Analysis in a Teacher Education Curriculum. University of California, Davis. Unpublished paper presented at the American Educational Research Association Convention, Chicago, February, 1968.
- Moser, J. A Case Study of the Effect of Information Feedback on the Performance of Student Teachers in Mathematics. University Microfilms, Ann Arbor, Michigan, 1965.
- Moskowitz, G. The Effects of Training in Interaction Analysis on the Attitudes and Teaching Patterns of Cooperating Teachers and Their Student Teachers. Temple University. Unpublished doctoral dissertation, 1966.
- Moskowitz, G. "The Attitudes and Teaching Patterns of Cooperating Teachers and Student Teachers Trained in Interaction Analysis," Interaction Analysis: Research, Theory and Application. E.J. Amidon and J.B. Hough (eds.). Boston: Addison-Wesley, 1967, pp. 271-282.
- McDonald, F.J., Allen, D.W., and Orme, M.E. Effect of Self Evaluation and Social Reinforcement on the Acquisition of a Teaching Behavior. Unpublished paper presented at the American Educational Research Association Convention, Chicago, February, 1966.
- McDonald, F.J., Allen, D.W., and Seidman, E. Televised Models for Teacher Training. Stanford University. Unpublished paper.

- Nelson, L. "Teacher Leadership. An Empirical Approach to Analyzing Teacher Behavior in the Classroom," Classroom Interaction Newsletter, Vol. 2, November, 1966, pp. 31-32.
- Nielson, G. Studies in Self-Confrontation. Copenhagen: Munkegaard, 1962.
- Oliver, D.W. and Shaver, J.P. "A Critique of 'Practice Teaching'," Harvard Educational Review, Vol. 31, No. 4, Fall, 1961, pp. 437-448.
- Olivero, J.L. Video Recordings as a Substitute for Live Observations in Teacher Education. Stanford University. Unpublished doctoral dissertation, 1965.
- Orme, M.E., McDonald, F.J., and Allen, D.W. Effect of Modeling and Feedback Variable on the Acquisition of a Complex Teaching Skill. Stanford University. Unpublished paper presented at the American Educational Research Association Convention, Chicago, February, 1966.
- Pankratz, R. "Verbal Interaction Patterns in the Classroom of Selected Physics Teachers," Interaction Analysis: Research, Theory and Application. E.J. Amidon and J.B. Hough (eds.). Boston: Addison-Wesley, 1967, pp. 176-185.
- Perlberg, A. An Analysis of Incentives to Stimulate Educators' Growth. Columbia University. Unpublished doctoral dissertation, 1958.
- Perlberg, A. and O'Bryant, D.C. Video Recordings and Micro-Teaching Techniques to Improve Engineering Instruction. College of Engineering, University of Illinois. Unpublished paper, 1968.
- Romney, G. and others. Patterns of Effective Teaching. Provo, Utah: Provo Board of Education, 1961.
- Romoser, R.C. "Change in Attitude and Perception in Teacher Education Students Associated with Instruction in Interaction Analysis," Dissertation Abstracts, Vol. 25, 1965, pp. 57-70.
- Sanders, N.M. Classroom Questions: What Kinds? New York: Harper & Row, 1966.
- Schueler, H., Gold, M., and Mitzel, H. The Use of Television for Improving Teacher Training and for Improving Measures of Student-Teaching Performance: Phase I. Improvement of Student Teaching. New York: Hunter College of the City University of New York, 1962.
- Schueler, H., Lesser, G.S. and Bobbins, A.L. Teacher Education and the New Media. Washington, D.C.: American Association of Colleges for Teacher Education, 1967.
- Sedgwick, L.K., and Misfeldt, H.T. "Micro-Teaching - New Tool For a New Program," Industrial Arts and Vocational Education, Vol. 56, No. 6, June, 1967, pp. 34-35.
- Sharp, G. Curriculum Development as Re-Education of the Teacher. New York: Bureau of Publications. Teachers College, Columbia University, 1951.

- Simon, A. The Effects of Training in Interaction Analysis on the Teaching Patterns of Student Teachers in Favored and Non-Favored Classes. Temple University. Unpublished doctoral dissertation, 1966.
- Soar, R. An Integrative Approach to Classroom Learning. Public Health Service, Final Report, No. 7-R11MH02045. Philadelphia: Temple University, 1966.
- Soar, R. "Pupil Needs and Teacher-Pupil Relationships: Experiences Needed for Comprehending Reading," Interaction Analysis: Research, Theory and Application. E.J. Amidon and J.B. Hough (eds.). Boston: Addison-Wesley, pp. 243-251.
- Sorenson, A.G. "What is Learned in Practice Teaching?" Journal of Teacher Education, Vol. 18, Summer, 1967, pp. 173-178.
- Sorenson, A.G. and Gross, C.F. Teacher Appraisal: A Matching Process. Los Angeles: UCLA CSEIP Occasional Report No. 4, 1967.
- Sorenson, A.G., Husek, T.R., and Yu, C. "Divergent Concepts of Teacher Role: An Approach to the Measurement of Teacher Effectiveness," Journal of Educational Psychology, Vol. 54, 1963, pp. 287-294.
- Springman, D.B. Secondary-Teacher Majors: Classroom Observations By Audio-Video-Tape Devices. Western Reserve University. Unpublished doctoral dissertation, 1965.
- Tucker, C.A. "Video Recordings Implement Teaching," Industrial Arts and Vocational Education, Vol. 56, No. 6, June, 1967, p. 37.
- Twelker, P.A. Simulation Applications in Teacher Education. Oregon State System of Higher Education. Unpublished paper, 1966.
- Voth, J.A. Effect of Video-Tape Recording Feedback on Teaching Behavior of Student Teachers. University of Missouri. Unpublished paper presented at the American Educational Research Association Convention, Chicago, February, 1968.
- Voth, J.A. and others. Helping Student Teachers Change Their Behavior. University of Missouri. Mimeographed paper, 1967.
- Weaver, W.J. "Video-Tape New Life Into Your Recruitment Program," Industrial Arts and Vocational Education, Vol. 56, No. 6, June, 1967, p. 36.
- Webb, C., and Baird, H. A Summary of Selected Research on Micro-Teaching. Brigham Young University. Unpublished paper presented at the Association for Student Teaching, Ogden, Utah, April, 1967.
- Weber, W.A. Teacher and Pupil Creativity. Temple University. Unpublished doctoral dissertation, 1967.
- Wright, D.L. A Study of Various Types of Training and Feedback on the Verbal Behavior and Attitudes of Teachers. Temple University. Unpublished doctoral dissertation, 1967.

Young, D.B. The Effectiveness of Self Instruction in Teacher Education Using Modeling and Video-Tape Feedback. University of Maryland. Unpublished paper presented at the American Educational Research Association Convention, Chicago, February, 1968.

Zahn, R. The Effect of Cooperating Teacher Attitudes on the Attitudes of Student Teachers. Glassboro State College. Unpublished paper.

Zahn, R. The Use of Interaction Analysis in Supervising Student Teachers. Temple University. Unpublished doctoral dissertation, 1965.

APPENDIX A

Excerpts from Student Teacher and Cooperating Teacher Reactions

"Good interest shown by students. People in the community had comments of inquiry as to what could be done with the equipment. I feel that this is an ideal way to review for constructive criticism of teaching techniques.

"Could be very valuable to evaluate students' work habits as well as the teacher's performance."

"Students did not seem to react overtly to presence of the equipment. I, as the instructor, was most interested in my mannerisms and reactions to students' questions. Cooperating teacher, who operated equipment, felt the time was well spent."

"Mine - the experience was helpful and contributed to my professional development as a teacher. Students - 'a stimulating method of material presentation;' 'the replay allowed me to check my comprehension of the material.'

"I offer my encouragement and hope that the scope of this project will be increased. The opportunity for replaying the tape and showing it to other teachers and evaluators gives me a chance to hear comments and suggestions about my performance. Keep up the good work."

"Microteaching has many worthwhile possibilities but could be more authentic and purposeful if the taping sessions were more candid and less staging. The officials of the school believe microteaching has many good possibilities."

"I feel that micro-teaching will be, in the future, a very worthwhile part of teacher training. It has the potential of being very helpful to the student teacher and I can see many possible uses for it in the classroom as an audio-visual aid.

"The first half of the micro-teaching experience (the sessions in the teaching techniques lab) were of most benefit to me. There are, however,

many parts of the process which need improvement. I believe much more could be gained from the half-dozen or so sessions if more preparation and guidance were given. In practice, the instruction and guidance in connection with micro-teaching would seem to fit best in the methods course. Both the methods course and the micro-teaching practice have the same goal - to introduce and encourage improvement and variation in teaching techniques, so the video tape equipment could serve as a very good laboratory for the course. Care should be taken, however, to structure the experiences enough via the methods class to let the student teacher know what is expected. Some starting points should be given, i.e. given a specific method the student may teach any subject using the method, or given a specific subject, the student may use any technique to teach it. I think the student should be urged to try various techniques in order to become familiar with them before entering the actual classroom."

APPENDIX B1

Equipment

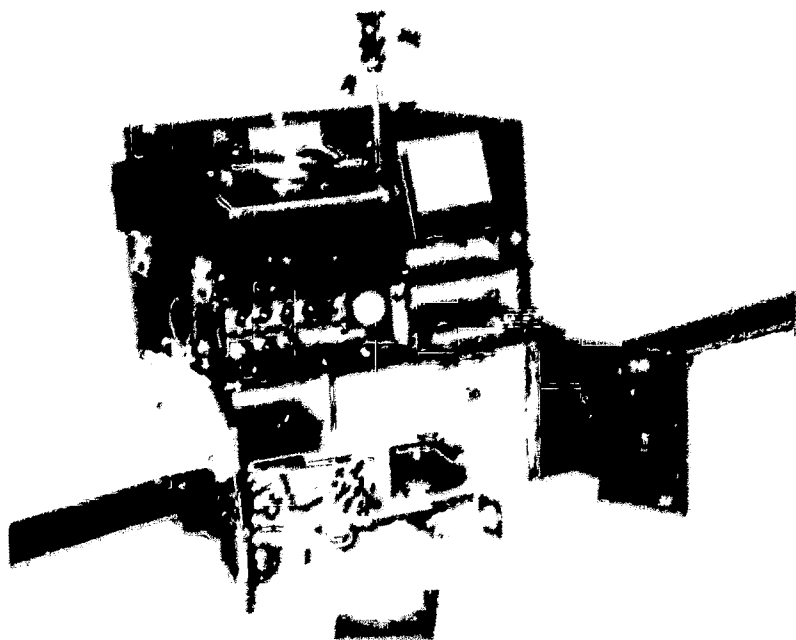

COMPLETE "MOBILE VIDEO CENTER"

This housing unit was designed and constructed specifically for the project at the University of Illinois. The camera support behind the monitor is a modified tripod, mounted permanently, allowing full elevation, panning and tilting of a normal tripod.

MOBILE VIDEO CENTER PARTIALLY SET UP

The Mobile Unit consists of a half-inch recorder, two cameras, two floor stand microphones, one lavalier microphone, a 9" television monitor, an amplifier-mixer and two special lenses which alternated between the two sets of equipment.

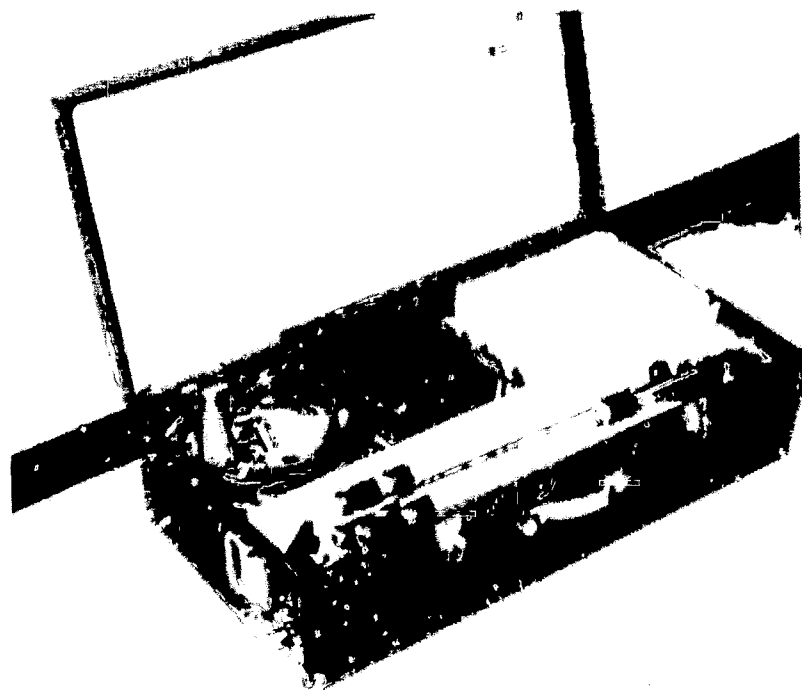
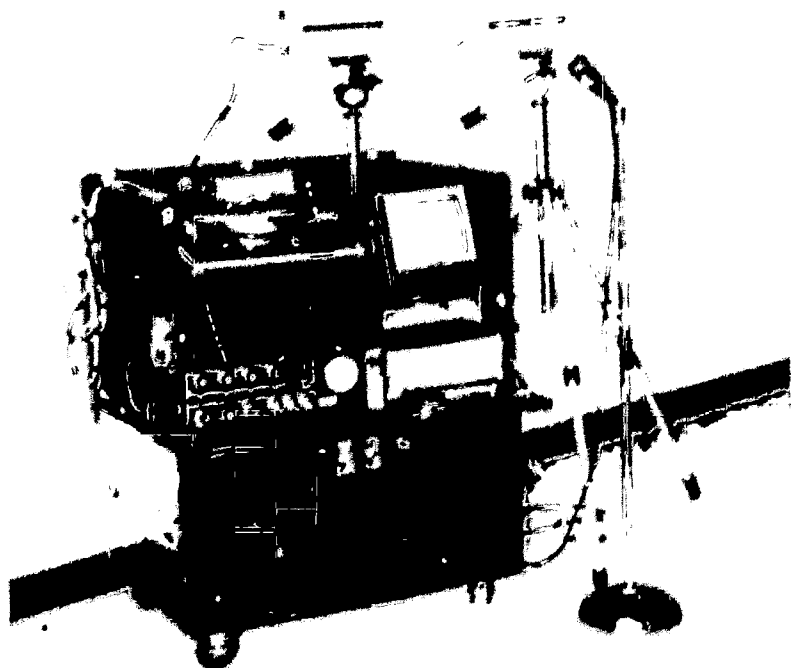

PORTABLE HOUSING UNIT TO ACCOMPANY RECORDER

This unit ("Portable Video Center") was designed to house all of the equipment included in the Mobile Video Center with the exception of the amplifier-mixer and one floor stand microphone. Without the mixer, a "Y-tap" was provided to accept both microphones.

APPENDIX B2
Transporting Equipment

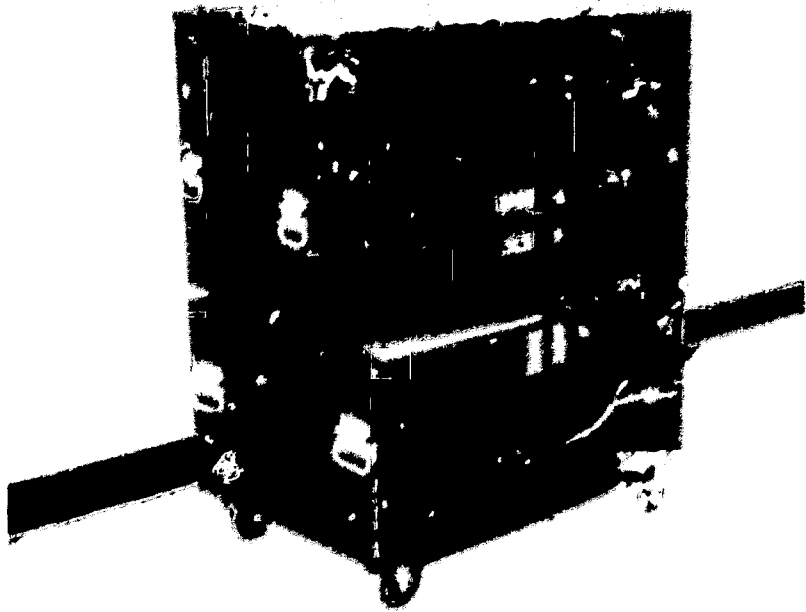

SEPARATING THE MOBILE VIDEO CENTER
FOR TRANSPORTING

Basic in the design of this unit was the need for placing it in a station wagon. Ball-type rollers were mounted under the top half to serve two purposes: (1) to facilitate loading and unloading, and (2) to serve as locating pins when the two units are assembled as one.

LOADING THE MOBILE VIDEO CENTER

After the unit has been moved to the curb on its casters, the top half is rolled into the station wagon, followed by the bottom half. To prevent rolling in transit, the two halves are fastened together with trunk clasps and the stationary casters of the bottom half are locked with two steel pins.

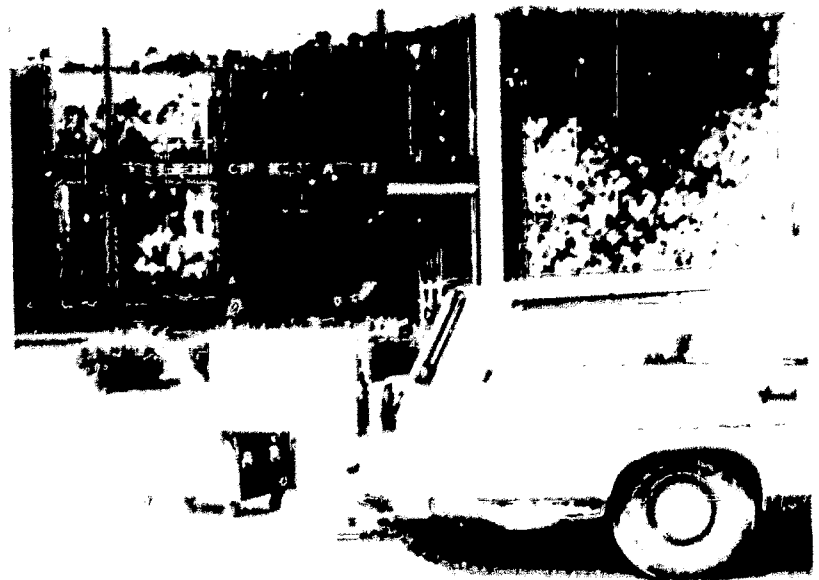

COMPLETE "PORTABLE VIDEO CENTER"

In designing the Portable Video Center housing unit to fit in a standard automobile, size and weight were given primary consideration. A castered platform provides easier movement. The recorder is carried like a suitcase.

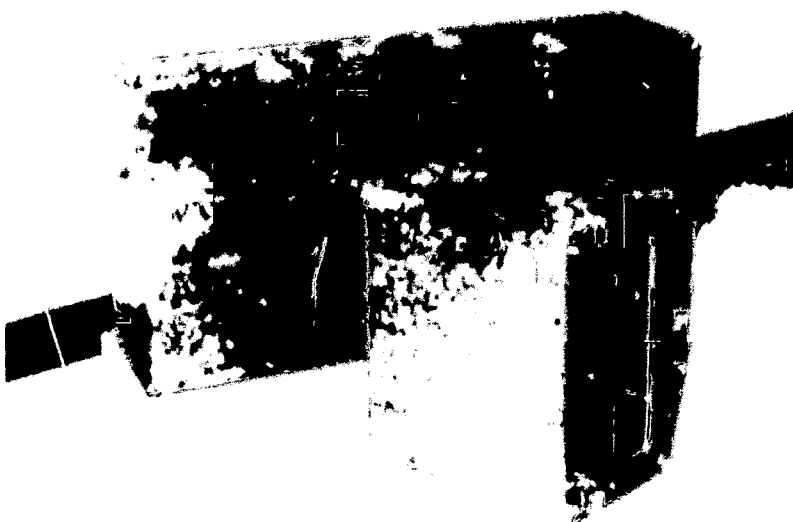

APPENDIX B3

Special Effects Equipment

Special Effects Equipment consists of a special effects generator, a sync generator, and a special lens. Splitting the screen horizontally, vertically or by quadrants, this equipment provides simultaneous viewing of teacher and students from two cameras. Other than the two lenses, the set shown on this page costs approximately \$900. Installed in a video recording system, the price would be approximately \$1,200. The costs of the zoom and the wide-angle lenses are \$350 and \$75 respectively.

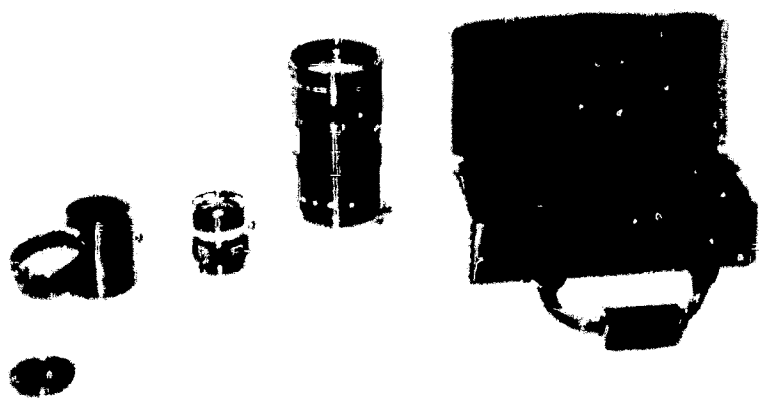
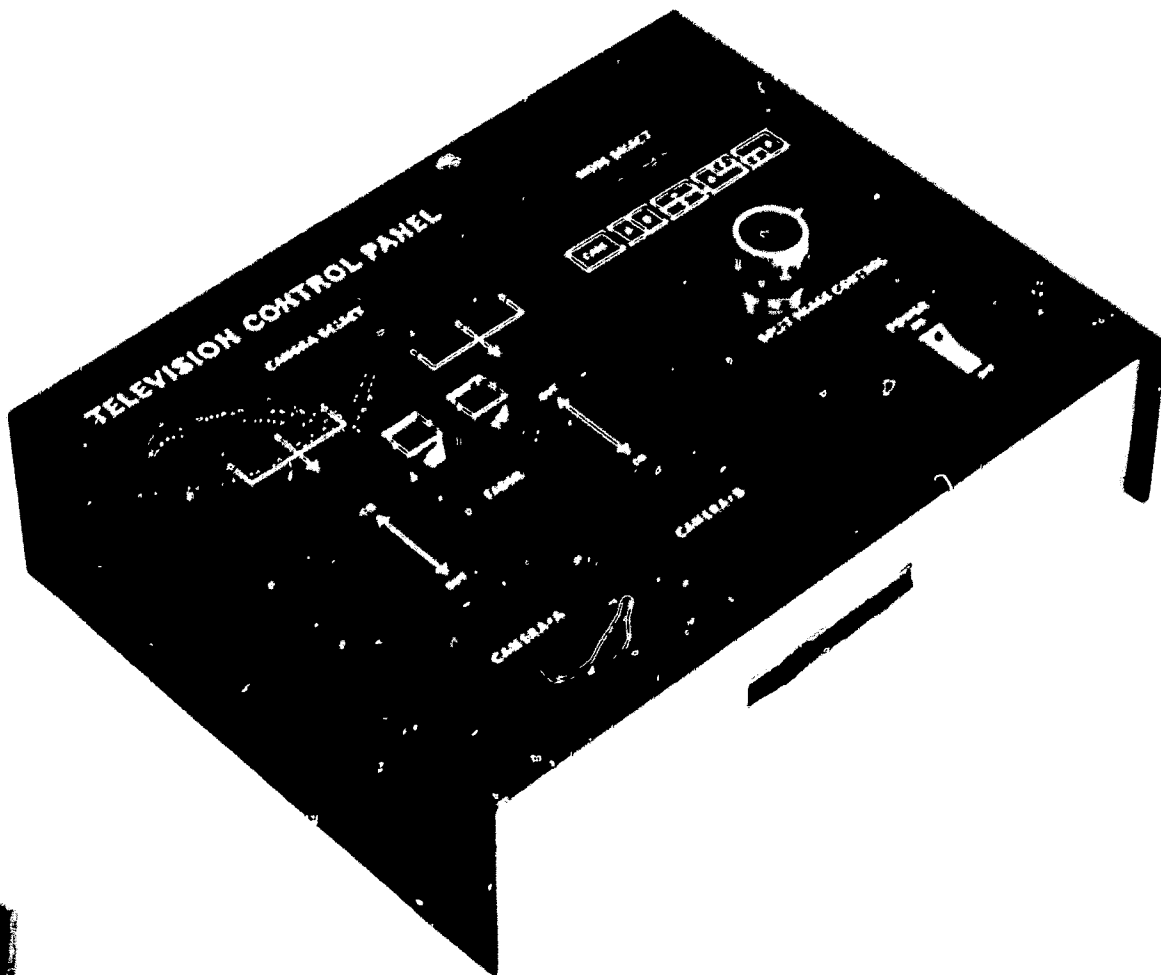

APPENDIX C1

INSTRUCTIONS FOR SETTING UP AND OPERATING

MOBILE VIDEO CENTER

INVENTORY CHECK LIST

1. Two cameras
2. Three microphones
3. One mounted T.V. monitor
4. One video recorder
5. One mounted amplifier
6. One mounted speaker
7. One mounted tripod
8. One portable tripod
9. Two mike stands with base
10. Two sets of video leads
11. One extension cord
12. One 110 volt power cord
13. One accessory kit
14. One take-up reel

PRECAUTIONS:

1. Always remove reels before fastening recorder cover for transporting the equipment.
2. Always have MOTOR SWITCH in "OFF" position when threading the tape.
3. Always avoid aiming camera directly into the sun or at high intensity light such as welding.
4. Always run motor in "STANDBY" position for ten minutes when equipment is brought in from the cold. This eliminates condensation.
5. Always have lens cap on lens when equipment is not in use. Cover lens before turning camera off.
6. Always keep tape as close to room temperature as possible.

1. Supply Reel Spindle
2. Power Button
3. Audio Level Control
4. Video Level Control
5. Motor Standby/
Motor Off Switch
6. Threading Diagram
7. Record Button

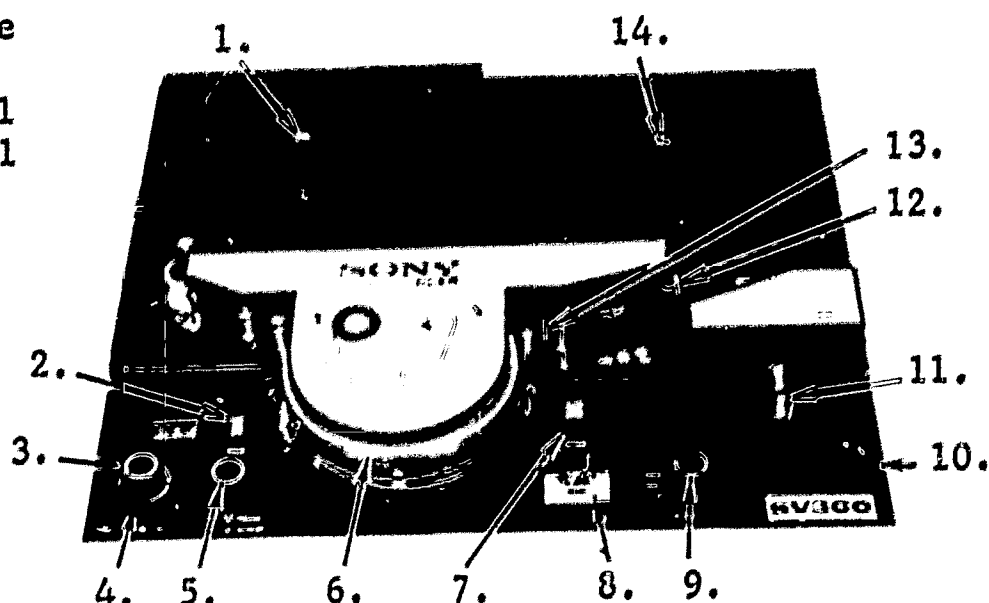

8. Level Meter
9. Meter Select Switch
10. Fast Forward Lever
11. Play-Stop-Rewind Lever
12. Tape Roller
13. Automatic hutoff
14. keep Reel spindle

WHEN YOU RECEIVE THE EQUIPMENT, the RECORD BUTTON should be 1/2" high, and the PLAY-STOP-REWIND LEVER should be in the "STOP" position. These are all on the top of the recorder. Also, the switch on the brown power supply box behind the recorder should be in the "OFF" position. The RECORD PLAYBACK switch behind the recorder should be in "RECORD".

SETTING UP AND CHECKING THE EQUIPMENT

1. Plug in black AC cord to 110 source and connect to outlet box in left end of unit.
2. Assembling camera on tripod.
 - a. Lengthen each tripod leg one section.
 - b. Extend tripod legs to maximum outward direction.
 - c. Unscrew small handle from the end of large handle and screw into tripod head.
NOTE: These handles lock the position of the head when they are turned clockwise.
 - d. Raise camera base on tripod to chest height and lock at that level.
 - e. Level camera base on tripod to horizontal position.
 - f. Tighten all knobs of tripod snugly.
 - g. Turn screw on tripod until threads protrude 1/4" above cork pad.

- h. Holding Camera #2 securely with lens opposite long handle of tripod, place threaded hold (bottom of camera) in position over the screw and tighten the screw as far as it will go with finger pressure.
 - i. Turn large black collar around screw in same direction as screw was turned and make it snug thus adding greater security.
 - j. Test the assembly to be sure camera is well fastened.
 - k. Place Camera #1 on mounted tripod head in same manner as Camera #2 was mounted.
3. Plug camera 110 leads to brown power supply box and connect at camera.
 4. Connect pink leads to cameras and outlet box.
 5. Connect green video lead to Camera #1 and outlet box video #1. Connect yellow video lead to Camera #2 and outlet box Video #2.
 6. Assemble mike stands and screw mike into stand.
 7. Plug mikes into outlet box. (Audio 1, 2, 3).

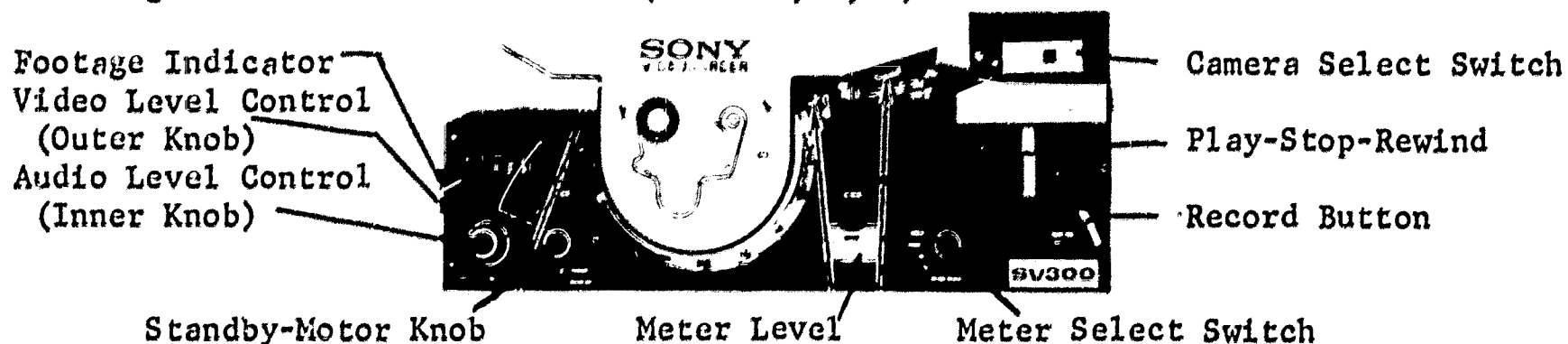

8. Put RECORD-PLAYBACK SWITCH in "RECORD". (Located on top of box behind recorder.)
 9. Thread tape from supply reel, placed on left spindle, to take-up reel on right spindle, following threading diagram on recorder.
NOTE: PLAY-STOP-REWIND LEVER must be in "STOP" position.
 10. Switch on power at brown power supply box behind recorder.
 11. Depress red RECORD BUTTON. (It will stay down)
 12. Unscrew lens cap and store carefully. (SHOULD NOW HAVE LIVE PICTURE)
 13. To check video:
Move METER SELECT SWITCH to "VIDEO",
CAMERA SELECT SWITCH to "CAMERA #1".
Check front collar of lens to be sure the red arrow points to "2.8" setting.
Adjust 2nd collar of lens to get maximum sharpness.
Repeat for 2nd camera with CAMERA SELECT SWITCH in "CAMERA #2"
-
14. To adjust video:
Move METER SELECT SWITCH TO "VIDEO" position.
Adjust VIDEO LEVEL CONTROL (outer knob, lower left) to have meter reading in green (There is no need to adjust for both cameras.)
 15. To adjust audio:
Move METER LEVEL CONTROL (inner knob, lower left) to have meter reading that seldom pegs the meter.
 16. Turn on by pulling STANDBY-MOTOR OFF KNOB up.

TO RECORD

1. Start footage indicator at 000 by pushing down on small black knob.
2. Hold down on red RECORD BUTTON; push PLAY-STOP-REWIND LEVER to "PLAY" (SHOULD STILL HAVE LIVE PICTURE, REELS REVOLVING).
3. Knob on side of speaker box should be turned counterclockwise to "OFF" position.
NOTE: During "RECORD," check and, if necessary, adjust AUDIO KNOB (lower left) for reading in the green area.
4. To change cameras, switch CAMERA SELECTOR to "1" or "2."

TO PLAYBACK

1. Move PLAY-STOP-REWIND LEVER to "STOP" position. Move right to "REWIND" position and stop at 000 reading on footage indicator.
2. Move RECORD-PLAYBACK KNOB to "PLAYBACK". (Located on top of box behind recorder.)
3. Move PLAY-STOP-REWIND LEVER to "PLAY".
4. Adjust VOLUME CONTROL KNOB on side of speaker.

DISMANTLING THE EQUIPMENT

1. Replace lens cover on both cameras.
2. Move PLAY-REWIND LEVER to "REWIND".
NOTE: Machine will turn off automatically when tape runs out.
3. Remove reels and store in appropriate containers.
4. Reset switches to following positions: The RECORD BUTTON should be 1/2" high; the PLAY-REWIND LEVER should be in "STOP" position. The switch on the brown outlet box should be in "OFF" position. The RECORD-PLAYBACK switch should be in the "RECORD" position. Push down MOTOR OFF SWITCH.
5. Disconnect all wires and store in cart.
6. Remove cameras from tripods and store in containers.
7. Dismantle tripod and store in cart.
NOTE: Small handle screws out of tripod head into the end of large handle. Screw must be level with cork surface.
8. Unscrew mikes and store in cart.
NOTE: Mike stand must be taken apart to be stored.

CLEANING ROTARY HEADS

BEFORE ATTEMPTING TO CLEAN ROTARY HEADS, DISCONNECT VIDEOCODER FROM EXTERNAL POWER SOURCE.

1. Move the rotary head to the groove for cleaning on the left side (see photo) by gently pushing the head around with the cleaning tip (supplied in the accessory kit).
2. Gently hold the edge of the rotary head with your finger tip to keep head from moving during cleaning.
3. Press the cleaning trip lightly against the head, and clean by moving the cleaning tip from right to left, NEVER MOVE THE CLEANING TIP VERTICALLY.
4. Move the other head on the opposite side around gently with the cleaning tip, and clean it in the same manner.

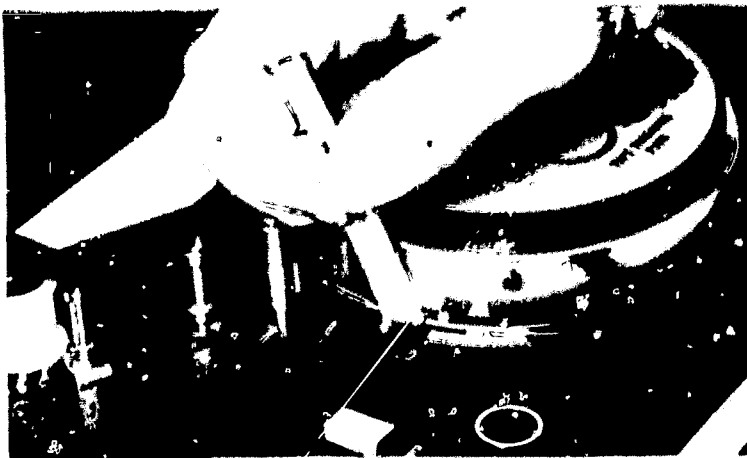

3/28/68

APPENDIX C2

INSTRUCTIONS FOR SETTING UP AND OPERATING

PORTABLE VIDEO CENTER

INVENTORY CHECK LIST

1. Two cameras
2. Two microphones
3. One T.V. monitor
4. One mike stand with base
5. One video recorder
6. Two sets of video leads
7. One 110 volt power cord
8. One extension cord

PRECAUTIONS:

1. Always remove reels before fastening recorder cover for transporting the equipment.
2. Always have MOTOR SWITCH in "OFF" position when threading the tape.
3. Always avoid aiming camera directly into the sun or at high intensity light such as welding.
4. Always run motor in "STANDBY" position for ten minutes when equipment is brought in from the cold. This eliminates condensation.
5. Always have lens cap on lens when equipment is not in use. Cover lens before turning camera off.
6. Always keep tape as close to room temperature as possible.

1. Supply Reel Spindle
2. Power Button
3. Audio Level Control
4. Video Level Control
5. Motor Standby/
Motor Off Switch
6. Threading Diagram
7. Record Button
8. Level Meter
9. Meter Select
Switch

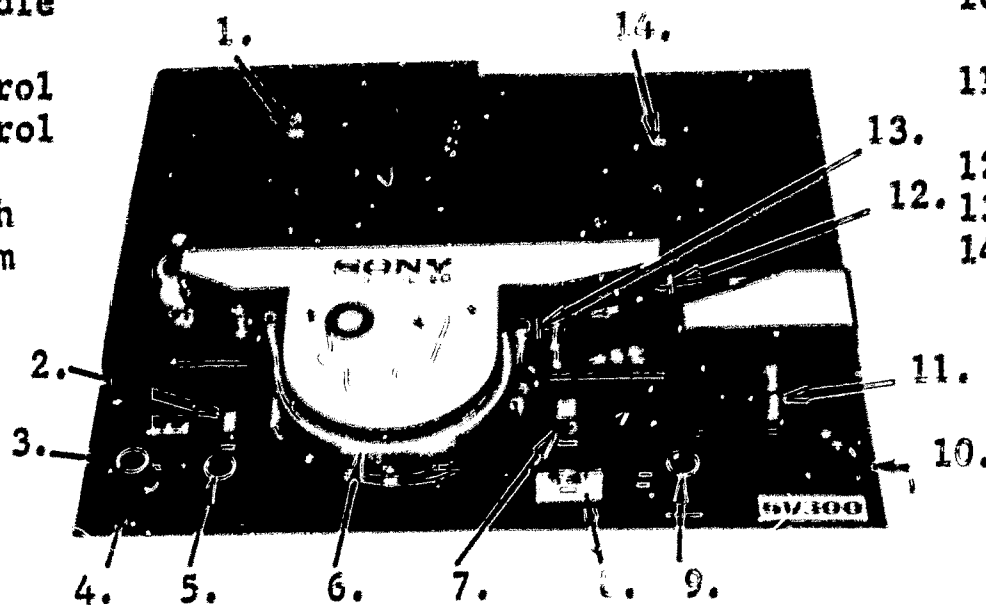

10. Fast Forward
Lever
11. Play-Stop-Rewind
Lever
12. Tape Roller
13. Automatic Shutoff
14. Takeup Reel
Spindle

WHEN YOU RECEIVE THE EQUIPMENT, the RECORD BUTTON should be 1/2" high, and the PLAY-STOP-REWIND LEVER should be in "STOP" position. These are all on top of the recorder. The OFF-ON SWITCH on the T.V. monitor should be in "OFF" position.

SETTING UP AND CHECKING THE EQUIPMENT

1. Assembling cameras on tripod.
 - a. Lengthen each tripod leg one section.
 - b. Extend tripod legs to maximum outward direction.
 - c. Raise camera base on tripod to chest height and lock at that level.
 - d. Level camera base on tripod to horizontal position.
 - e. Tighten all knobs of tripod snugly. NOTE: Handles lock the position of the head when they are turned clockwise.
 - f. Turn screw on tripod until threads protrude 1/4" above cork pad.
 - g. Holding Camera #2 securely with lens opposite long handle of tripod, place threaded hold (bottom of camera) in position over the screw and tighten the screw as far as it will go with finger pressure.
 - h. Turn large black collar around screw in same direction as screw was turned and make it snug thus adding greater security.
 - i. Test the assembly to be sure camera is well fastened.
 - j. Place Camera #1 on other tripod head in same manner as Camera #2 was mounted.

2. Place recorder on convenient horizontal surface (minimum size: 16" X 26", and remove top.
 3. Place T.V. monitor at right of recorder facing operator (remove shield).
 4. Assemble mike stand and screw mike onto stand. (Place near recorder for testing purposes.)
 5. Connect all leads according to color coding to back of recorder, except for the plugs labeled "TO CAMERA".
 6. Connect green video lead to Camera #1, and yellow video lead to Camera #2.
 7. Connect pink leads to cameras.
 8. Plug camera 110 leads to power supply (back of recorder) and connect at camera.
 9. Connect 110 volt power cord to the recorder. NOTE: Cord has twist lock plug. Insert and turn right to assemble.
 10. Thread tape from supply reel, placed on left spindle, to take-up reel on right spindle, following threading diagram on recorder.
- NOTE: PLAY STOP REWIND LEVER must be in "STOP" position.

Sequence in turning equipment on. To prevent damage to the equipment, it is essential that the switches with red labels 1 through 4 be turned on in that order.

1. Turn on #1 switch on TV monitor.
2. Turn on #2 switch on Camera.
3. Turn on #3 switch on recorder.

NOTE: The #3 switch is turned on and off by simply depressing the gray button. "ON" position is depressed. "OFF" position is up.

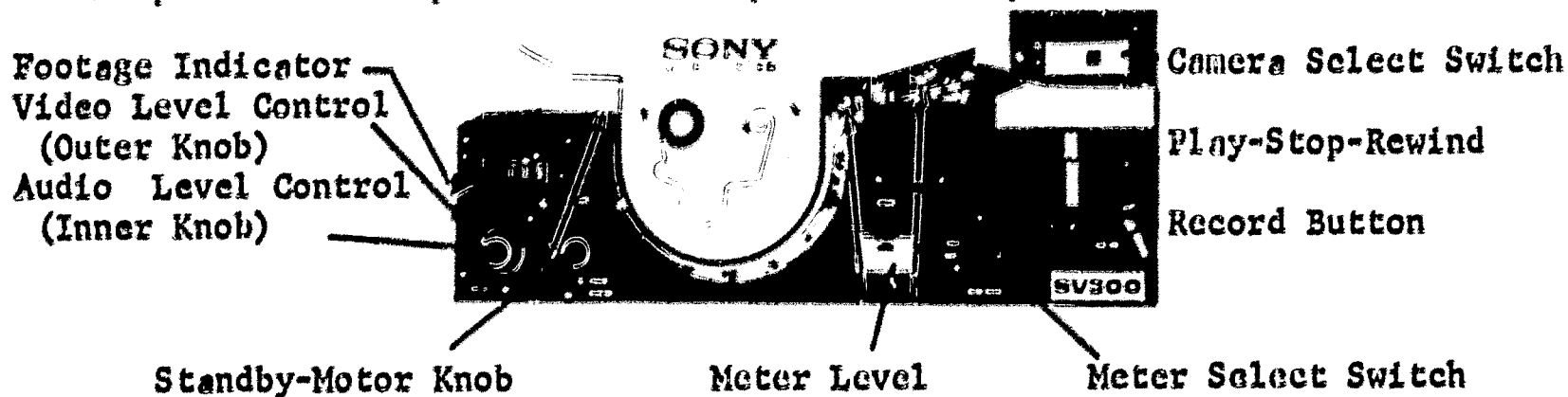

4. Depress red RECORD BUTTON. (It will stay down.)
5. Unscrew lens cap and store carefully. (SHOULD NOW HAVE LIVE PICTURE)
6. To check video:

Move METER SELECT SWITCH to "VIDEO".
CAMERA SELECT SWITCH to "CAMERA #1".
Check front collar of lens to be sure the red arrow points to "2.8" setting.
Adjust 2nd collar of lens to get maximum sharpness.

Front Collar

Second Collar



Repeat for 2nd camera with CAMERA SELECT SWITCH in "CAMERA #2".

7. To adjust video:

Move METER SELECT SWITCH to "VIDEO" position.
Adjust VIDEO LEVEL CONTROL (Outer knob, lower left) to have meter reading in green. (There is no need to adjust for both cameras.)

8. Turn on by pulling STANDBY-MOTOR KNOB #4 up.

TO RECORD

1. Start footage indicator at 000 by pushing down on small black knob.
2. Hold down on red RECORD BUTTON: push PLAY-STOP-REWIND LEVER to "PLAY."
(SHOULD STILL HAVE LIVE PICTURE, REELS REVOLVING).
3. OFF-ON SWITCH on monitor should be turned counterclockwise to low position but not to "OFF" position.
4. Turn "AUDIO LEVEL" knob to maximum setting, extreme clockwise. (Inner knob, lower left).
5. To check audio, move METER SELECT SWITCH to "AUDIO" position; should have meter reading that seldom pegs the meter.

TO PLAYBACK

1. Move PLAY-STOP-REWIND LEVER to "STOP" position. Move right to "REWIND" position and stop at "000" reading on footage indicator.
2. Move PLAY STOP REWIND LEVER to "PLAY".
3. Adjust volume with OFF-ON knob on front of monitor. (Turn clockwise)

DISMANTLING THE EQUIPMENT

1. Replace lens cover on both cameras.
2. Move PLAY-STOP-REWIND LEVER to "REWIND".
NOTE: Machine will turn off automatically when tape runs out.
3. Remove reels and store in appropriate containers.
4. Turn off equipment in following order: #4, #3, #2, #1
NOTE: Move PLAY STOP REWIND LEVER to "STOP".
5. Disconnect all wires and store in case.
NOTE: 110 power cord has a twist lock plug. Turn left and pull to disengage.
NOTE: Both the light blue and the copper color coded plugs have releases which must be pushed to withdraw plug.
6. Remove cameras from tripods and store in case.
7. Dismantle tripod and store in case.
8. Unscrew mike and store in case. NOTE: Mike stand must be taken apart to be stored.
9. The cords that are bound together are left connected to monitor.

CLEANING ROTARY HEADS

BEFORE ATTEMPTING TO CLEAN ROTARY HEADS, DISCONNECT VIDEORECORDER FROM EXTERNAL POWER SOURCE.

1. Move the rotary head to the groove for cleaning on the left side (see photo) by gently pushing the head around the cleaning tip (supplied in the accessory kit).
2. Gently hold the edge of the rotary head with your finger tip to keep head from moving during cleaning.
3. Press the cleaning tip lightly against the head, and clean by moving the cleaning tip from right to left. NEVER MOVE THE CLEANING TIP VERTICALLY.
4. Move the other head on the opposite side around gently with the cleaning tip, and clean it in the same manner.

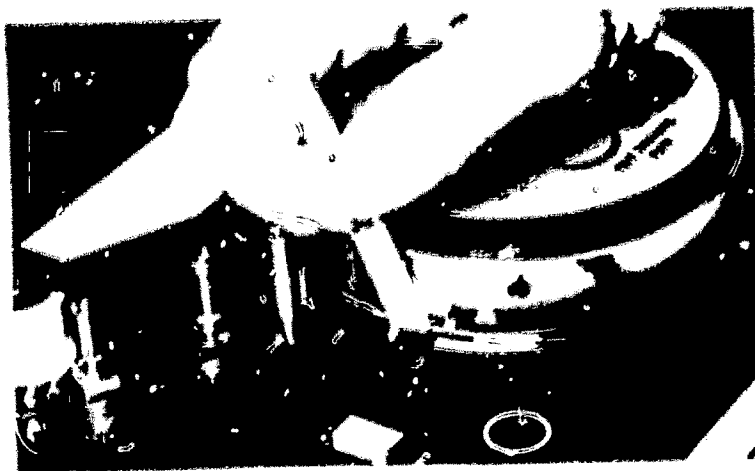

3/28/68

VOTEC MICRO-TEACHING PROJECT
INSTRUCTIONS FOR USING ZOOM LENS

TO MOUNT ZOOM LENS

1. Remove standard lens from camera by revolving it counterclockwise as viewed from front of camera; store in plastic container.
2. Remove zoom lens from black leather container.
3. Unscrew cap from small end of zoom lens and store in black leather container.
4. Remove small ZOOM CONTROL HANDLE from black leather container and screw into small hole in middle collar of zoom lens.
5. Screw small end of zoom lens into camera, revolving it clockwise.
6. Turn camera on and remove lens cover.

TO ADJUST LENS

1. Check back collar to be sure the arrow points to "2.8" setting.
 2. Adjust zoom to "25MM" (wide picture) position by moving ZOOM CONTROL HANDLE counterclockwise as viewed from the operator's position.
 3. Adjust NEAR-FAR KNOB on back of camera for maximum sharpness.
 4. Adjust zoom to 100MM (close-up) position by moving zoom control clockwise.
 5. Focus lens by revolving front collar of zoom for maximum sharpness.
- NOTE: If the focusing changes in the process of zooming, it is because the NEAR-FAR KNOB on back of camera is not in the correct position. In this case, it is necessary to go through steps 2, 3, 4, and 5 again.

REMOVING AND STORING ZOOM LENS

1. Replace lens cover.
2. Turn camera off.
3. Remove ZOOM CONTROL HANDLE from lens and store in black leather container.
4. Remove zoom lens from camera by revolving counterclockwise.
5. Screw cap onto small end of zoom lens and store in black leather container.
6. Remove standard lens from plastic container and screw into camera revolving it clockwise.

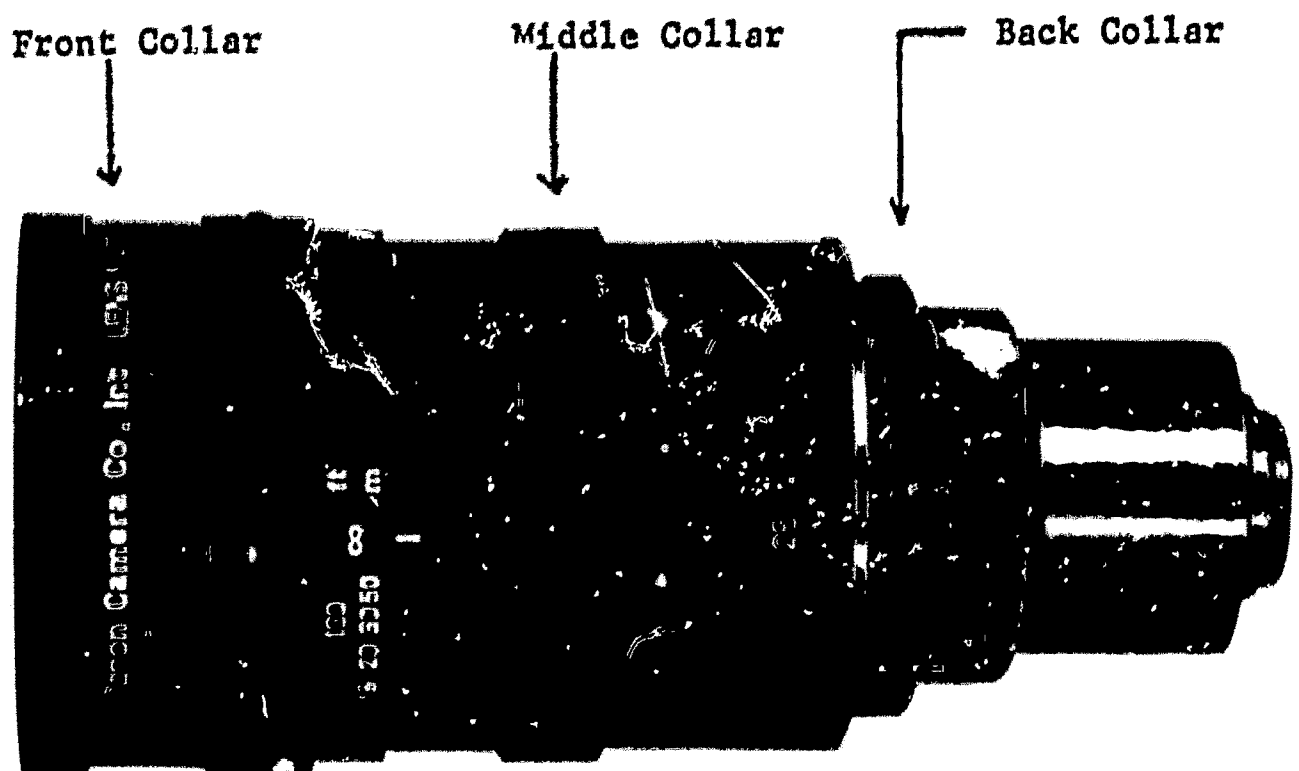

3/28/68

APPENDIX D

Developing Model Tapes on One-Half-Inch Sony Equipment

Dubbing (without captioning or voice override) Procedure

(Note: Two recorders and a TV monitor are required.)

Connections

1. On Recorder #1 place the tape containing the portion to be transferred.
2. On Recorder #2 place the fresh tape which will receive the dubbed portion.
3. Connect the jack "Video Out" on Recorder #1 to "Video In 1" on Recorder #2.
4. Connect "Audio (or "Line") Out" on Recorder #1 with "Audio (or "Line") In" on Recorder #2.
5. For viewing of model tape being dubbed, connect "Video Out" on Recorder #2 to "Video In" on TV monitor and "Audio Out" to "Audio In" on the monitor.

Procedures

1. Turn Recorder #1 on "Play" and Recorder #2 on "Record."
2. Check both the audio and video levels on Recorder #2 by playing part of the selection to be dubbed and adjust accordingly.
3. On Recorder #1, note the footage for the section of tape to be transferred, for example, from 037 to 059.
4. Stop both recorders and rewind tape. Bring Recorder #2 back to 000. Recorder #1 should be brought back to the original 037 plus five feet which would then be 032. The additional five feet will allow the picture to stabilize before being transferred to the new tape, thus minimizing the rolling of the picture on the model tape.
5. Turn Recorder #1 to "Play."
6. When 037 footage appears, turn Recorder #2 on "Record."
7. When 059 footage appears on Recorder #1, stop Recorder #2 and Recorder #1 in that order.
8. Repeat this operation for each portion being transferred.
9. The quality of the recording depends on the accuracy of the operator in anticipating the time for switching of the machines. This calls for the trial and error method and each dubbed portion of the recording should be viewed when completed.

Dubbing (with captioning) Procedure

(Note: Two recorders, a TV monitor, and a set of letters for captioning are required.)

Connections

1. On Recorder #1 place the tape containing the portion to be transferred.
2. On Recorder #2 place the fresh tape which will receive the dubbed portions.
3. Connect the jack "Video Out" on Recorder #1 to "Video In 1" on Recorder #2.
4. Connect "Audio (or "Line") Out" on Recorder #1 to "Audio (or "Line") In" on Recorder #2.
5. For viewing of model tape being dubbed, connect "Video Out" on Recorder #2 to "Video In" on TV monitor and "Audio Out" to "Audio In" on the monitor.
6. Mount camera on tripod and connect the jack "Video Out" on camera to "Video In 2" on Recorder #2.

Procedures

1. Move "Camera Select" switch to "Camera #2."
2. Depress "Record" button on Recorder #2 and position camera on captioning while viewing monitor.
3. Move "Camera Select" switch to "Camera #1."
4. Turn Recorder #1 on "Play" and Recorder #2 on "Record."
5. Check both the audio and video levels on Recorder #2 by playing part of the selection to be dubbed and adjust accordingly.
6. Move "Camera Select" switch to "Camera #2" and check "Video Level" adjustments by changing the "Beam" adjustment on the camera.
7. Stop Recorder #1 and bring back to 000 reading and Recorder #2 to 031 reading.
8. Turn on Recorder #2 and start to record captioning.
9. Turn Recorder #1 to "Play."
10. When 037 footage appears on Recorder #1, move "Camera Select" switch to "Camera #1."

11. When 059 footage appears on Recorder #1, stop Recorder #2 and Recorder #1 in that order.
12. Repeat the operation for each portion being transferred, checking the progress of the model tape after each addition

Dubbing (with captioning and voice override) Procedure

(Note: Two recorders, a TV monitor, a set of letters, a microphone, an audio "Y-tap," and an audio cable with "Off-On" switch are required.)

Connections

1. On Recorder #1 place the tape containing the portion to be transferred.
2. On Recorder #2 place the fresh tape which will receive the dubbed portions.
3. Connect "Y-tap" to "Audio (or "Line") In" on Recorder #2.
4. Connect microphone to one side of "Y-tap."
5. Connect audio cable with "Off-On" switch (in "Off" position) from other side of "Y-tap" to "Audio Out" on Recorder #1.
6. Connect the jack "Video Out" on Recorder #1 to "Video In 1" on Recorder #2.
7. For viewing of model tape being dubbed, connect "Video Out" on Recorder #2 to "Video In" on TV monitor and "Audio Out" to "Audio In" on the monitor.
8. Mount camera on tripod and connect the jack "Video Out" on camera to "Video In 2" on Recorder #2.

Procedures

1. Move "Camera Select" switch to "Camera #2."
2. Depress "Record" button on Recorder #2 and position camera on captioning while viewing monitor.
3. Move "Camera Select" switch to "Camera #1."
4. Turn Recorder #1 on "Play" and Recorder #2 on "Record."
5. Check both the audio and video levels on Recorder #2 by playing part of the selection to be dubbed and adjust accordingly.

6. To check the number of feet needed for voice override:
 - a. Begin recording on Recorder #2 and note footage reading.
 - b. Speak into microphone using prepared script.
 - c. When finished with script, stop Recorder #2 and note footage reading.
 7. Rewind Recorder #2 to 000 reading and Recorder #1 should be brought back to original 037 plus the number of feet needed for the prepared script.
 8. Turn Recorder #2 on "Record" and Recorder #1 on "Play."
 9. Speak into microphone using prepared script.
 10. When 037 footage appears move "Camera Select" switch on Recorder #2 to "Camera #1" position and audio "Off-On" switch in cable to "On."
 11. When 059 footage appears on Recorder #1, stop Recorder #2 and Recorder #1 in that order.
 12. Repeat this operation for each portion being transferred, checking the progress of the model tape after each addition.
- (Note: Patience is required in developing model tapes. In some cases several tries are needed to obtain the quality of tape desired.)

APPENDIX E

Participants

STUDENT TEACHERS

Jack H. Alvers	Patrick La Van	Norman Sohan
James Brown	David Lawrence	Karen Rodde
William Claxon	James Lesniak	Ann Brookhart
Allen Gablesen	Edward Lynch	Charles Heavner
Henry Gross	Randall Martin	Richard Jenkins
Roger Hembreiker	John Parker	Robert Cobb
Daniel Inman	Paul Skolaski	George Young

COOPERATING TEACHERS

William Rich, Sullivan High School, Sullivan, Illinois

Donald Prather, Clinton High School, Clinton, Illinois

Helen Green, St. Charles High School, St. Charles, Illinois

Patricia Cote, Carl Sandburg High School, Orland Park, Illinois

Raymond Anderson, Evanston Township High School, Evanston, Illinois

William Clanton, Evanston Township High School, Evanston, Illinois

Charles Griest, Champaign Central High School, Champaign, Illinois

Jerrel Hofer, Urbana High School, Urbana, Illinois

Joseph Houska, Champaign Central High School, Champaign, Illinois

James Kichefski, West Campus High School, Joliet, Illinois

Gordon Maves, Evanston Township High School, Evanston, Illinois

Robert Pittman, Champaign Central High School, Champaign, Illinois

James Reeder, Paxton High School, Paxton, Illinois

Paul Savageau, Evanston Township High School, Evanston, Illinois

Dale Stretch, Hillsboro High School, Hillsboro, Illinois

Felix Wheeler, Danville Junior College, Danville, Illinois

Alvin Wilcox, Danville Junior College, Danville, Illinois

UNIVERSITY OF ILLINOIS
TEACHING TECHNIQUES LABORATORY



TEACHER PERFORMANCE APPRAISAL SCALE

APPENDIX F

	30%		15%		15%		15%		10%	
	WEAK	BELOW AVERAGE	AVERAGE	STRONG	SUPERIOR	OUTSTANDING	TRULY EXCEPTIONAL			
AIMS										
A. Were the learning aims of this micro-lesson understood?	1 no understanding	2 doubtful understanding	3 some understanding	4 generally understood	5 good understanding	6 clearly understood	7 exceptional understanding			
B. Were the learning aims of this micro-lesson developed?	1 no development	2 doubtful development	3 some development	4 generally developed	5 good development	6 clearly developed	7 exceptional development			
CONTENT										
C. Was the content of this micro-lesson meaningful?	1 no meaning	2 doubtful of meaning	3 some meaning	4 generally meaningful	5 mostly meaningful	6 clearly meaningful	7 superior meaningfulness			
D. Was the content of this micro-lesson well organized?	1 not organized	2 unclear organization	3 some organization	4 generally organized	5 good organization	6 clearly organized	7 exceptional organization			
METHOD										
E. Was the method employed appropriate to the aims of the micro-lesson?	1 not appropriate	2 doubtful of appropriateness	3 not entirely appropriate	4 generally appropriate	5 appropriate	6 clearly appropriate	7 exceptionally appropriate			
F. Was the method employed stimulating to the learner?	1 not stimulating	2 little stimulation	3 some stimulation	4 generally stimulating	5 stimulating	6 very stimulating	7 exceptionally stimulating			
G. Was the method employed successful in terms of the lesson's learning aims?	1 not successful	2 little success	3 some success	4 generally successful	5 successful	6 clearly successful	7 exceptionally successful			
EVALUATION										
H. Did the teacher evaluate his success by keeping in contact with the learners?	1 no contact	2 little contact	3 some contact	4 generally in contact	5 in contact	6 very much in contact	7 exceptional contact			
I. Did the teacher's method of lesson evaluation encourage learner participation?	1 no encouragement	2 little encouragement	3 some encouragement	4 generally encouraging	5 encouraging	6 clearly encouraging	7 exceptional encouragement			
ACCOMPLISHMENT										
J. Does the learner have a feeling of accomplishment concerning this micro-lesson?	1 nothing accomplished	2 little accomplished	3 some accomplishment	4 general feeling of accomplishment	5 lesson accomplished	6 clearly accomplished	7 exceptional accomplishment			

THE USE OF VIDEO
TAPE RECORDERS AND
MICRO-TEACHING TECHNIQUES
TO IMPROVE INSTRUCTION IN
VOCATIONAL-TECHNICAL
PROGRAMS IN ILLINOIS

FINAL REPORT

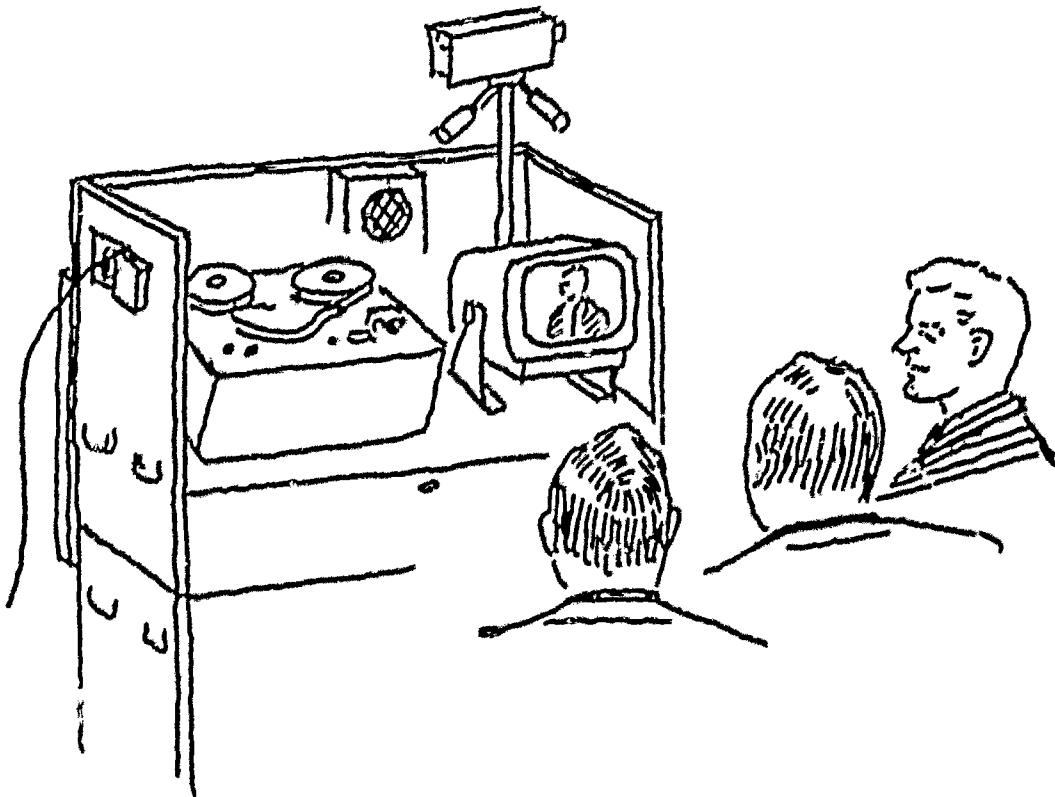

A. PERLBERG
R. TINKHAM
R. NELSON

PART ONE:
IN-SERVICE
STUDY

VTU07319

Conducted by the Department of Vocational and Technical Education, College of Education,
University of Illinois

In cooperation with the Illinois Board of Vocational Education and Rehabilitation

THE USE OF PORTABLE VIDEO TAPE RECORDERS AND MICRO-TEACHING TECHNIQUES
TO IMPROVE INSTRUCTION IN VOCATIONAL-TECHNICAL PROGRAMS IN ILLINOIS

A PILOT STUDY

Arye Perlberg, Director*
Robert A. Tinkham, Co-Director
Richard L. Nelson, Research Associate

FINAL REPORT

Study Number One: Improving In-Service Education

September 15, 1967 to August 15, 1968

Department of Vocational and Technical Education
College of Education
University of Illinois
Urbana, Illinois

in cooperation with

Research Coordinating Unit
Vocational and Technical Education Division
Board of Vocational Education and Rehabilitation
U.S. DEPARTMENT OF HEALTH, EDUCATION & WELFARE
OFFICE OF EDUCATION

THIS DOCUMENT HAS BEEN REPRODUCED EXACTLY AS RECEIVED FROM THE
PERSON OR ORGANIZATION ORIGINATING IT. POINTS OF VIEW OR OPINIONS
STATED DO NOT NECESSARILY REPRESENT OFFICIAL OFFICE OF EDUCATION
POSITION OR POLICY

*Dr. Arye Perlberg is a Visiting Associate Professor in the Departments of Vocational and Technical Education, College of Education and General Engineering, College of Engineering, University of Illinois, Urbana. He is on leave from the Technion-Israel Institute of Technology, Haifa, Israel.

Dr. Robert A. Tinkham, Associate Professor of Industrial Education in the College of Education at the University of Illinois, is head supervisor of industrial education student teachers.

Mr. Richard L. Nelson is a research associate who served as Assistant Supervisor of Industrial Education student teachers at the University of Illinois.

PREFACE

Traditionally, in the United States and more so the world over, the preservice and in-service development of pedagogical competencies of vocational-technical teachers has been slighted. Emphasis has been placed on developing competency in technical skills and theoretical subject matter relating to a trade or occupation. These skills were acquired mainly by occupational experience and some type of formal learning. It was natural for vocational-technical educators to assume that the pedagogical skills would also be acquired through practical experience, trial and error.

In recent years there has been, however, a growing realization among vocational-technical educators that formal professional education should receive greater attention than it has been given in the past. There is an awareness of the need to expand existing programs and improve their quality. It is essential, however, that steps in this direction include an examination of evolving changes and application of innovations in the general area of teacher education and an evaluation of their potentialities for vocational-technical teacher education.

Two innovations, portable video recorders and micro-teaching techniques, have captured the attention of teacher educators in recent years. A growing number of educational institutions across the country are investigating the potential inherent in these new techniques and media for preservice teacher education and the improvement of instruction of experienced teachers. At the University of Illinois, the College of Education has established a micro-teaching laboratory equipped with portable video tape recorders to improve the training of new teachers. The Department of General Engineering has been engaged in a project using these techniques to improve instruction on the higher education level.

In comparison to other segments of the educational community, vocational-technical education has been slow in exploring the possibilities inherent in these innovations. The study reported herein is one of the first conducted by vocational-technical educators on the adoption of these techniques and media.

The effective adoption of video tape recordings and micro-teaching techniques to vocational-technical teacher education requires systematic research and experimentation. Before such detailed structural studies are undertaken, however, there is need for pilot studies to explore and examine the feasibility aspects and the problems encountered in the experimentation and adoption of these innovations.

The following is a report of such an exploration. This study was conducted in the Department of Vocational and Technical Education, College of Education, at the University of Illinois in Urbana, and supported by a grant from the Research Coordinating Unit, Division of Vocational and Technical Education, Illinois State Board of Vocational and Technical Education and Rehabilitation. The investigation has been conducted in two areas: (1) in-service training programs in area vocational schools and the vocational-technical programs of junior colleges and (2) training and supervising student teachers in vocational-technical education. Aspects of each study and the findings and analysis will be presented in separate reports.

ACKNOWLEDGEMENTS

Many individuals and agencies made this study possible and we are indebted to all of them. The project director wishes to acknowledge in particular the Dean of the College of Education, Rupert N. Evans, and the Head of the Department of Vocational and Technical Education, M. Ray Karnes, for inviting him to spend his sabbatical in full-time research at the University of Illinois.

Professor Dwight Allen, one of the originators of Micro-Teaching, formerly at Stanford University and at present Dean of the School of Education at the University of Massachusetts, Amherst, has provided advice, materials, and constant encouragement for which the researchers are indebted.

The Illinois Research Coordinating Unit (RCU), the Vocational Technical Education Division, Board of Vocational Education and Rehabilitation, provided funds for this project. We acknowledge especially the encouragement given by Vernon E. Burgener, RCU Coordinator of Research, and Robert K. Gray, Research Consultant. The University of Illinois, through its College of Education and the Department of Vocational and Technical Education, provided advice and encouragement in the preparation of the research proposal and during the research activities.

Professor William D. Johnson of the College of Education, Teaching Techniques Laboratory, has consulted with the researchers and encouraged students participating in this project to use the Teaching Techniques Laboratory services.

We acknowledge the cooperation of our colleagues, Professors Mary Mather and Paul Hemp, and their associates, Kenneth Knell, Mrs. Bessie Hackett and Alfred Mannebach, in allowing us to pursue this research with some of their student teachers and cooperating teachers. We are also indebted to the participating student teachers, cooperating teachers, and their schools for their cooperation.

Michael Alig, of the College of Education Television Center, helped to develop and maintain our video recorder system in excellent working condition. We would like to express our appreciation to Miss Ruth Gorrell and the typists in the Stenographic Office for typing the final manuscript of this report.

Last, but not least, we are especially indebted to Miss Lois Oldham who labored with us in typing and editing the many drafts of this report.

TABLE OF CONTENTS

	Page
Preface	iii
Acknowledgements	v
CHAPTER	
I. Introduction	1
II. New Media in In-Service Education	5
III. Findings and Discussion	12
IV. Video Tape Recording Systems: Technical Aspects	21
V. Conclusions and Recommendations	29
Bibliography	-2
APPENDIX	
A. Excerpts from Teacher Reactions	
B1. Equipment	
B2. Transporting Equipment	
B3. Special Effects Equipment	
C1. Instructions for Setting Up and Operating Mobile Video Center	
C2. Instructions for Setting Up and Operating Portable Video Center	
D. Developing Model Tapes on One-Half-Inch Sony Equipment	
E. Participants	
F. Teacher Performance Appraisal Scale	

CHAPTER I

INTRODUCTION

In-Service Education

Professional development through in-service training is imperative in most professions and occupations. The basic premise is that in-service training programs enable individuals to keep abreast of new developments and facilitate changes in occupational behavior which are necessitated by these new developments.

In comparing the nature and results of in-service training programs in education with those of other professions and occupations, it appears that most are geared to achieve cognitive and attitudinal changes rather than behavioral changes. University courses are the main in-service training system for educators. The majority of these courses are verbal, abstract, and, in some cases, vague; often teachers attending these courses do not acquire the knowledge and sensitivity to understand classroom interaction. Very little is done to equip teachers with skills and behavior strategies that would enable them to handle classroom situations.

There is a trend toward local institutional programs designed to achieve behavioral changes. Lectures by "educational experts," are predominant in many of these programs. An analysis of their results reveals that many of them do not affect significantly the teachers' behavior. Few local in-service educational programs are conducted as workshops, which provide opportunities for discussion and involvement. Even in these cases, much is to be desired in achieving a real change in teachers' classroom behavior.

The introduction of innovations and achievement of changes in education through in-service programs is slower than in other professions. This is especially true for innovations which have direct impact on the teacher's behavior.

Vocational-technical educators have traditionally been more critical of professional education and in-service training programs than other educators. Being involved in teaching technical skills and subject matter related to the performance of these skills has created a state of mind which appreciates practical and concrete things. Many of them have been skeptical about the value of professional education programs in which a direct, clear relationship between what is learned and its application to the teaching-learning process in the classroom is not obvious. This is probably one of the major reasons for the low regard that many vocational-technical educators have toward professional education.

The following is a description of a pilot study in which it was hypothesized that the use of video tape recordings and micro-teaching techniques in in-service training programs in vocational-technical education is instrumental in achieving behavioral change in the teaching process.

The Purpose and Objectives of the Study

The purpose of the study was to validate the following hypotheses: (1) A confrontation with his classroom behavior, as presented on video tape recordings will increase the teacher's awareness of the need to modify certain behavioral patterns in the classroom and (2) a systematic analysis of the video tape recordings and the development of competency in specific teaching skills through micro-teaching techniques will facilitate this change.

The objectives of the study were as follows:

1. To train personnel in charge of instruction in area vocational centers and junior colleges chosen for experimentation in various areas of micro-teaching techniques and portable video tape recorders.
2. To introduce the faculties of these schools to these techniques and media and their uses in improving instruction.
3. To observe and evaluate the activities of the project and to explore the problems involved in pursuing these methods of behavior modification in these schools.
4. To prepare interim guidelines and suggestions for schools interested in using these techniques and media to improve instruction.

Research Method

This pilot study was designed to obtain qualitative data. Such data are essential for the design of a structured research project which would evaluate, in qualitative measures, the effectiveness of these media and techniques. The findings of this study and their implications should be viewed as tentative until further research data are attained to support them.

The Procedures

The Stephen Decatur Area Vocational Center in Decatur, Whiteside Area Vocational Center in Sterling, Danville Junior College, and Parkland College in Champaign were selected as participants in this study. Intensive work was concentrated at Stephen Decatur Area Vocational Center and the Occupation-Oriented Department of Danville Junior College.

In the first phase, two or three representatives from each school participated in a workshop conducted at the University of Illinois. The program included a theoretical introduction to research on teaching with particular emphasis on observation of classroom interaction, video tape

recordings as feedback mechanisms, and micro-teaching techniques. The operation of video tape recorders was also demonstrated.

Subsequent orientation meetings were arranged in Decatur, Danville, and Sterling for the purpose of describing the basic concept, media, and research procedures. In the cases of Danville and Sterling, the meeting was arranged for the entire college and high school faculty. The researchers then met at Danville Junior College with the Occupation-Oriented Department faculty. Separate meetings were arranged with small groups of teachers to acquaint them with the video taping units.

Equipment was left at the school for use in experimentation with taping in the classroom and in evaluating the tapes. Faculty members were given the option of participating in this Project, and a significant number indicated willingness to take advantage of the opportunity.

In order to obtain a better diagnostic measure of the participants' teaching behavior which needed modification, the "Illinois Course Evaluation Questionnaire" was administered to their students. This instrument is used at the University of Illinois and a number of other universities and colleges to evaluate instruction and instructors. Though it primarily shows student evaluation of a specific course as a whole, several aspects of the questionnaire reflect competency in certain teaching skills.

The application of micro-teaching techniques was carried out through the following procedures. The teachers participating in the project were generally taped in short sequences of their classes (10- to 15-minute sessions). These tapes were analyzed by the teacher and a project staff member. Areas in the teacher's classroom interaction which needed modification were highlighted, and strategies for achieving such changes were discussed. Teaching skills specific to the needs of each teacher and each lesson were practiced. Another taping session of a regular lesson was arranged in which the teacher experimented with these modifications to his classroom instruction.

At Stephen Decatur Area Vocational School, several teachers were given opportunities to be taped and analyzed; however, intensive work (which consisted of four taping sessions) was carried on with two teachers only. Activities in this school were conducted during a period of several weeks in the first semester.

At Danville Junior College, classroom behavior modification was pursued during both semesters. Seven teachers were taped, five of which had an opportunity for more intensive analysis of their tapes with project staff members.

Equipment*

To carry out the study two sets of one-half-inch video taping equipment were used, each consisting of two cameras, a recorder, a small TV monitor, three microphones, and an amplifier-mixer which permitted more than one microphone to be used simultaneously. Two different units were designed and constructed to house the equipment and to transport it between the schools.

The Scope of the Study

The range of activities in this pilot study was limited. Researchers and equipment were also engaged in a study designed to evaluate the use of these media and techniques to improve student teaching activities. Since student teaching periods are fixed by a regular university schedule, availability of staff and equipment and thus, the activities of this study, were dictated by the student teaching project.

The shortage of staff time and limited availability of equipment forced the researchers to restrict the number of active participants in the study and the intensity of their participation.

* A more elaborate description of the equipment is presented in Chapter IV.

CHAPTER II

NEW MEDIA IN IN-SERVICE EDUCATION

In-Service Education As A Process of Change and Reeducation

Corey, in describing the evolving changes in the concept of in-service education, states:

In-service education of school personnel has always had as its objective the improvement of professional behavior. Acquiring new attitudes and learning new knowledge were but means to this end. For many years, however, it was generally believed that learning about ways and means of improving instruction would stimulate changes in practice that would result in these improvements. It was generally believed, too, that some one in authority in the schools--the supervisor or the administrator--could directly tell teachers how to better their instruction with the result, again, of rapid improvement.

These conceptions of desirable ways of bringing about change in professional behavior are no longer considered valid...^{1/}

Coffey and Golden view in-service education as a process of change and emphasize the importance of understanding the psychology of change within an institution as a prerequisite to effective in-service training programs.^{2/} Perlberg, adapting the basic concept that in-service education should aim at achieving behavioral change, proposes incentives which will aid in creating a climate conducive to change.^{3/}

The modern concept of in-service education as a process of change is based heavily on writings of Lewin, who refers to education as a process of change and reeducation.

The re-educative process affects the individual in three ways. It changes his cognitive structure, the way he sees the physical and social worlds, including all his facts, concepts, beliefs, and expectations. It modifies his valences and values, and these embrace both his attractions and aversions to groups and group standards, his feelings in regard to status differences, and his reactions to sources of approval or disapproval. And it affects motoric action, involving the degree of the individual's control over his physical and social movements.^{4/}

- 1/ Corey, Stephan M. "Introduction," in Henry, Nelson B. (ed.). In-Service Education for Teachers, Supervisors and Administrators. The Fifty-Sixth Yearbook of the National Society for the Study of Education. Chicago: The University of Chicago Press, 1957, pp. 2-3.
- 2/ Coffey, Hubert S. and Golden, William P., Jr. "Psychology of Change within an Institution," Ibid., p. 67.
- 3/ Perlberg, Arye. "An Analysis of Incentives to Stimulate Educators' Growth." Columbia University. Unpublished Doctoral Thesis, 1958.
- 4/ Lewin, Kurt. "Conduct Knowledge and Acceptance of New Values," Resolving Social Conflicts. New York: Harper and Brothers, 1948, p. 59.

A parallel of these categories of change is seen in evaluating in-service teacher education programs, especially those conducted in educational institutions. The emphasis in existing programs appears to be on the cognitive change. The attitudinal change, which is achieved through involvement of the person concerned, is not stressed. The motoric or behavioral change is given even less attention.

Lewin also suggests that the reeducation process frequently involves only the formal system of values, the level of verbal and emotional expression, and not behavior. This may heighten the discrepancy between the super-ego (the way one ought to feel and behave) and the ego (the way one actually feels and behaves) and thus develop guilt feelings and bad consciences which may lead to high emotional tension.^{5/}

Here again, an examination of present in-service education programs reveals that teachers are being told in general terms how to behave. Very little is being done to provide direction and to help them implement desired modes of classroom interaction. This situation creates anxieties and frustration, or skepticism toward professional education and in-service training programs.

It should be conceded that existing difficulties in understanding human behavior in the area of the teaching-learning process and the variables which determine it has forced teacher educators often to be vague, elusive or "theoretical" (a more accepted term). With an increased emphasis in educational research on the teaching-learning process, educators are able to provide more concrete direction.

A certain amount of conflict is probably necessary to motivate change. Miel stresses the importance of utilizing dissatisfaction with existing conditions, which seems to be a prerequisite to any intentional change.^{6/} Sharp suggests the necessity of providing a "model" to imitate in order to achieve a behavioral change.^{7/} Though self-discovery of appropriate and effective behavior is most desirable, it is usually a long, involved process which many teachers are not able to do on their own.

The use of portable video tape recorders and micro-teaching techniques in in-service education counteracts some of the criticism of existing programs and offers new opportunities for the improvement of instruction in schools.

^{5/} Ibid., p. 63.

^{6/} Miel, Alice. Changing the Curriculum - A Social Process. New York: Appleton-Century-Crofts, Inc., 1946, p. 40.

^{7/} Sharp, George. Curriculum Development as Re-Education of the Teacher. New York: Bureau of Publications, Teachers College, Columbia University, 1951.

The simulation of classroom situations and feedback through these innovations provides content of supervisory and analytical discussion on teachers' classroom behavior and permits analysis at a level of precision and actuality which has never before been possible.^{8/} The feedback mechanism of video tape can create a certain amount of dissatisfaction. Micro-teaching techniques offer the teacher something real and concrete by giving him the opportunity to practice and adopt the new modes of behavior.

The following is a discussion of the nature of these new media and techniques and their relevance to the improvement of teaching processes. Within the limits of this report, it is impossible to discuss in great length the theoretical background and the results of research on the use of these innovations. However, a comprehensive bibliography on micro-teaching, feedback mechanisms, and related areas is included in the Appendix.

Feedback As An Instrument of Change

Accurate feedback plays a cardinal role in the modification of teaching performance. Feedback facilitates the analysis and comparison of the teacher's behavior with generally accepted criteria and behavioral objectives; it aids in the reinforcement of approved behavioral patterns and creates dissatisfaction with the undesirable; it is instrumental in establishing new behavioral objectives for the individual teacher and in determining whether they are attained. Thus, adequate feedback can motivate the teacher and facilitate the modification of his behavior.

Traditionally, classroom interaction was described in vague terms by teachers and researchers alike. A better understanding of this complex phenomenon has been gained in recent years with the development of various methods of observing, analyzing, and measuring classroom behavior. Medley and Mitzel describe a number of systems designed to measure classroom behavior (of both the teacher and pupils) by systematic observation.^{9/} Many of these systems have since been modified and sophisticated through extensive research. The growing interest in research studies on observation systems of teacher behavior is evident in the literature and the research papers presented in recent conventions.^{10/}

^{8/} Schueler, H., Lesser, C. S. and Bobbins, A. L. Teacher Education and the New Media. Washington, D.C.: American Association of Colleges for

^{9/} Medley, D. M. and Mitzel, H. E. "Measuring Classroom Behavior by Systematic Observation," Handbook of Research on Teaching. N. L. Gage (ed.). Chicago: Rand McNally and Company. 1963, pp. 247-328.

^{10/} As reported at the 1967 and 1968 American Educational Research Association Conventions.

One serious limitation of systematic observation methods is that they are based on the written report of someone whose perception may be impaired by intrinsic factors or disturbances in the classroom.

The use of audio tape to record classroom activities permits repeated analysis of classroom interaction by several individuals, thus removing some of the personal distortion. It also enables the teacher involved to analyze his own activities. However, both live and audio systematic observation methods are limited to verbal interaction in classroom and eliminate many important nonverbal variables inherent in the classroom interaction. A proposed modification of classroom behavior based on an analysis of verbal interaction alone could be rejected because it does not provide the "whole picture" of what occurs in the classroom.

Feedback through Portable Video Recorders

The utilization of portable video tape recorders permits the recording of events in the classroom with minimum disturbance to the teacher and students. Relatively inexpensive facilities, using two cameras, permit simultaneous recording of the teacher's classroom interaction; both pictures (split screen) are projected by the recorded tape.

Video recording is not new and a number of teachers have been taped in the past, for the most part, in television studios, and, in a few cases, in their own classrooms. In many cases, taping of classroom activities in a studio has turned the lesson into a performance. Taping in regular classrooms with extensive, and expensive, television equipment has also disrupted the atmosphere of the classroom and distorted the natural process of the teacher-student interaction.

The technological innovation of portable video recorders provides an instant, accurate feedback of classroom interaction as a whole (verbal and nonverbal) in the teacher's natural habitat, his classroom. It provides a basis for reliable analysis and decisions about desirable modification in classroom behavior.

The Psychological Impact of Video Recordings

Teachers, like other human beings, may have ambivalent feelings toward feedback mechanisms. Though they can provide the sense of direction essential for the continuation of any activity, feedback mechanisms may also require a modification of behavior, which can cause uncertainty, discomfort, and even anxiety in the individual.

In the past, teachers have been able to accept unpleasant feedback of their classroom behavior by rationalizing that it was inaccurate or subjective or distorted by the observer. In many cases, they failed to remember things that were reported. Some of these memory failures may be viewed as defense mechanisms which are instrumental in relieving anxiety created by facing the truth.

An entirely different situation eventuated with the introduction of portable video recorders. Feedback can now be accurate; defense mechanisms previously employed cannot be used. Reality in its nakedness is available to the teacher. What he needs now is the desire to confront himself and the courage to accept what he sees.

The teacher's ambivalence of viewing his image is evidenced in feelings of anxiety and curiosity. There is a certain fascination in seeing one's own image; it is the magic of the mirror, the visual echo.^{11/} This narcissistic fascination may motivate him to take the chance and look at himself.

After the teacher has overcome the anxiety of initial observation, it would seem that nothing would be more convincing to him to modify his teaching behavior than the true picture of his classroom interaction. When used properly, this traumatic self-confrontation can greatly enhance the teacher's readiness for change.

There are a number of studies in teacher education and closely related areas such as counselor training which verify the effectiveness of video tape recordings and playback techniques in providing knowledge of results, especially behavior modification and the acquisition of complex skills.^{12/}

Micro-Teaching Techniques

Micro-teaching^{13/} is a teaching encounter scaled down in class size and time. Micro-class size is usually three to six students and the lesson lasts five to 20 minutes. The purpose of micro-teaching is to provide prospective student teachers with a substantial amount of actual teaching practice before they engage in student teaching at their assigned schools. This is done with optimum control and evaluation procedures without jeopardizing the learning of regular classroom pupils.

^{11/} Nielson, Gerhard. Studies in Self Confrontation. Copenhagen: Munkegaard, 1962.

^{12/} See Alexander, Bloom, Kagan, Maccoby, Maier, and Schuler in bibliography.

^{13/} The term "micro-teaching" was coined by Dwight Allen of Stanford University while pioneering in the application of the system to teacher education.

The micro-teaching process usually takes place in "teaching laboratories," where video tape recordings are used to provide feedback. In each lesson the student practices a specific skill, such as the ability to lecture, ask questions, lead a discussion, demonstrate, etc. The tape is viewed immediately after the presentation and is critiqued by the student teacher with the aid of a supervisor and by the written feedback of an evaluation questionnaire completed by students in the laboratory classroom. In some cases, an "improved" version of the lesson is planned and taught immediately to another micro-laboratory class. At other times, the new version is taught several days later.

Micro-teaching is being employed not only in preservice teacher education and as a research tool to explore training effects under controlled conditions, but as a method for experienced teachers to use in gaining knowledge of their interaction with students and in analyzing this feedback in a systematic way. Micro-teaching also facilitates exploration of new teaching techniques. In his discussion of the various uses of micro-teaching, Allen suggests that the

Experienced teacher may gain new insights through adaptation of the micro-teaching model. Under the present framework, if a teacher wishes to try a new approach in a particular lesson, he must wait until the following year to test alternatives to that lesson. In micro-teaching, the teacher can experiment with several alternatives with a limited number of students each time, with the opportunity for immediate evaluation and additional trials. Following this limited application, the plan can then be presented to the classroom. In this way, teachers may experiment with new methods and new content without the risk of defeating student learning and with much more satisfactory timing.

The micro-teaching clinic is an effective stimulus for the improvement of teacher performance after a performance plateau is reached in early tenure. The most effective teachers attain a high level of performance early in their careers. Unfortunately, they rarely have the stimulus to further increase their competence. Providing them with an opportunity to try new ideas easily and without risk to student learning can be an important asset to professional development.^{14/}

Since its inception, the micro-teaching model has been modified in many ways. Experimentation at Stanford and other universities has yielded positive results; however, the innovators have indicated the need for further exploration to find optimal models for the use of micro-teaching in teacher education.^{15/} A growing number of educational researchers are experimenting

^{14/} Allen, D. W. Micro-Teaching: A New Framework for In-Service Education (Unpublished paper). Stanford, California: Stanford University, 1966, p. 2.

^{15/} Stanford Teacher Education Program. Micro-Teaching: A Description. Stanford, California: Stanford University, 1967.

with modified models of micro-teaching techniques or combinations of micro-teaching and systematic observational methods. The most common combination is probably micro-teaching and interaction analysis.

Although many of the advantages of micro-teaching techniques and portable video recorders seem logical, much research is needed to prove their validity and to propose optimal uses to increase teacher effectiveness.

CHAPTER III

FINDINGS AND DISCUSSION

The following is a description of the findings, a discussion of problems made evident by Project activities, and proposals of strategies to alleviate these problems. Some of the suggestions are general in nature and can be adapted by any school system planning to engage in similar activities; others should be considered by those contemplating research in this area. The order in which the problems are presented is no indication of their relative importance.

Orientation of the Project

Key people in the participating school systems were introduced by telephone to the purpose of the Project, the media, and techniques. Material describing the Project was sent to each school. All of the individuals contacted agreed to participate; however, final agreement was made when the school administrator appointed two or three people to attend the orientation workshop at the University.

Several suggestions resulted from the experience gained in these orientation procedures. First, more intensive investigation should be made before selecting school systems used in experimentation. In addition to the initial contact by phone or letter, visits should be made to study the system, the faculty composition of the department involved, its relationship to other departments in the system and the administration, and prevailing attitudes toward innovation. "Gate blockers" and "gate openers"^{16/} to the introduction of change into the system should be identified. Conditions conducive to introducing change and the administration's readiness to promote meaningful participation in the Project should also be ascertained. A short orientation session at each school with key people should be conducted before the time of the workshop, in order to provide a realistic picture of the nature of the project, and the benefits to, and responsibilities of, the school or college.

The criteria for selecting participating systems should be in general readiness and definite positive attitudes toward the proposed activities. However, it is also important to experiment with systems which are not overly responsive but are willing to participate with some reservation. In such systems, the real challenge is to overcome resistance to change. The project staff should be involved to a certain degree in the selection of participants to the workshop to assure that those chosen will be agents of innovation in the system.

^{16/} A term used by Kurt Lewin in Lewin, K. and Grabbe, P. (eds.). "Problems in Re-education," Journal of Social Issues, 1945, No. 3.

University Orientation Workshop

A one-day workshop, which was devoted to theoretical orientation and a limited practice in the use of micro-teaching techniques and the operation of video recorders, was conducted at the University. It was held on a Saturday, requiring the participants to contribute their free time. It is recommended that longer workshops be conducted on school time or during vacations, some of which would offer university credit. Such workshops should provide a better acquaintance with the problems of research in teaching and related areas. There should be more opportunity to practice in a micro-teaching laboratory. It is important that each participant take the role of teacher, learner, and observer.

Other methods of classroom observation, such as interaction analysis, should be understood to stimulate exploration, in combining new methods in in-service programs. Special attention should be given to the problems of introducing innovations to school systems.

Teachers' Attitudes Toward the Media and Techniques

This study did not include a systematic quantitative analysis of faculty attitudes toward the use of these techniques and media in in-service education programs. The following remarks are based on general impressions of the researchers and key people with whom they worked in each system. Moreover, it was difficult to determine whether opinions expressed by the faculty were related to the specific use of these media and techniques, which can be perceived as a burden or threat, or if reaction was made to administrators and university staff who intruded into the teachers' relatively quiet world by suggesting that improvement of teaching be pursued.

It should be emphasized that the limitations of staff and equipment forced the researchers to restrain efforts in introducing these innovations. They did not want to interest too many teachers in the project and then frustrate them by not being able to involve them in intensive activities.

The reaction of faculty to the rationale of the project was different in each of the school systems involved, and this seems to be due to the orientation method and the composition of the faculty. In one case, the presentation was made to a group of 15 teachers. In the discussion that followed, the faculty seemed reluctant to commit themselves to participation in project activities. Such public declaration may have been considered a sign of weakness, an admittance that the teacher's instruction needed improvement, or a commitment which could not be withdrawn. However, several teachers, after the meeting, expressed readiness to experiment with the media and techniques.

It should be stressed that the researchers expected participants to the workshop to prepare the faculty for the orientation meeting. Material describing video recordings and micro-teaching were distributed. From the teachers' reactions, it appeared that they had not read the material. This may explain in part their reservation.

In another system, orientation was made not only to those within the department involved in the project but to the junior college faculty as a whole. A letter was written by the college president encouraging teachers to read the descriptive material and to attend the meeting. Participation at the meeting indicated that many had read the material. Favorable attitudes were expressed, particularly by figures of authority in the college. The faculty was not asked on this occasion to make a commitment.

A second meeting was held a week later with the faculty of the department. Most faculty members seemed emotionally ready for this meeting, a significant number of them expressed interest in the experiment. Questions raised at the meeting were specific and constructive. Researchers felt acceptance of the idea but did not pressure faculty members to commit themselves, although they were informed that staff and equipment limitations would not permit intensive work with all interested persons.

After completion of the project, those in charge of project administration at the college level felt that about one-third of the faculty was actively interested in activities while another third was passive. The remainder expressed some resentment and apprehension toward the project.

Generally speaking, the teachers who engaged in project activities recognized the importance of these media and techniques in the improvement of instruction. Care must be taken in predicting the reaction of teachers who were engaged in an inadequate number of taping sessions because their attitudes may change when they are involved in more intensive work.

Some of the teachers participating in the project expressed ambivalent feelings toward the proposed activities. They agreed theoretically that there was need for continual improvement and that involvement in activities designed to improve instruction on a regular basis was desirable. Moreover, there was probably some inducement in the possibility of seeing oneself on a television screen minutes after being taped. The experience with this innovation seems to have a special appeal of some of them. One teacher, when asked about the uniqueness of video taping as compared with audio taping, said, "After all, humans, like monkeys, are fascinated when looking at themselves."

On the other hand, the same teachers may have been anxious about facing themselves and reluctant to accept what they saw. They may have been apprehensive about developing dissatisfaction with their behavior. Moreover, even when they overcame these hurdles, there was a fear that this feedback would be used administratively to their disadvantage.

Avoidance Mechanisms

Verbal expression of willingness to cooperate in the experiment may be only one side of the ambivalent feeling toward actual participation. When the teacher's anxieties overran his logical readiness, he may employ overt and covert mechanisms to avoid self-confrontation. This phenomenon was evident in several ways.

On most occasions, equipment was left in the school for a few days. Teachers who were familiar with the operation of the equipment were advised to experiment with taping of classes or of role-playing situations. They were allowed to erase any tape, or, if they desired, could analyze the tapes with the project staff. It was hoped that the fascination of seeing themselves on tape would encourage faculty experimentation with the equipment. A number of the instructors did take advantage of the availability of equipment and taped themselves. However, the researchers' expectations proved to be too optimistic.

Difficulties in scheduling taping activities provided an opportunity to avoid being taped and analyzed. The researchers were aware of numerous problems in the area of administration and logistics. It is essential, however, to recognize that these difficulties were utilized in some cases by some teachers, as avoidance mechanisms.

In other cases, teachers preferred not to be taped because the nature of the lesson or subject matter did not lend itself to taping or because "there is not adequate time to prepare a lesson that is good enough for taping." These statements indicate the deep anxiety with which these teachers viewed the taping procedures. It seemed that some teachers were not as concerned about how a lesson was presented to students, but when it had to be taped, they became very aware of its quality.

Some tried to avoid entirely self-confrontation and others preferred to view themselves only in the presence of a consultant. Although they had the option of being the only one to see the tapes, some teachers were apprehensive about viewing themselves. They were advised that immediate review was most desirable. In some cases, there were legitimate logistic or technical

difficulties which prevented immediate viewing. However, there were many who did not see the tape until a week later during their analysis session with the researcher.

Improving Instruction and Teachers Load

An intellectual and emotional eagerness to use these media and techniques is not enough. The teacher must have the time, energy, and supportive conditions to pursue modification of classroom interaction. The teacher's heavy teaching load and his involvement in school or other activities were, in some cases, great obstacles to efforts to modify behavior. The magnitude of these obstacles is increased when coupled with anxieties about these media and techniques.

Intensive participation requires the teacher to prepare new teaching strategies after each review of tape. Changes in teaching technique may require a search for problems, changes in lesson content, formulation of questions and the preparation of audio-visual aids. However, it is unrealistic to expect teachers with approximately 20 contact hours a week to devote much time to such activities.

It is suggested that when a school system establishes an in-service program utilizing video recorders and micro-teaching techniques, participants be divided into two groups. One group would consist of teachers who would like to "try it out." They would be taped several times and engage in an evaluation of tapes. This kind of participation should be viewed as an orientation program, and the teacher would engage in these activities in his own time. A second group would consist of teachers, exposed to the media and techniques, who are willing to engage in intensive work. These teachers should be released from some of their teaching and other school duties to enable them to devote time and energy to these activities. The fact that the school considered it important, worthy of release from some of their duties might motivate them to contribute more of their own time. Moreover, such an arrangement would indicate to them and to the rest of the faculty the school's sincere interest in the improvement of instruction.

It would seem that intensive work with a small group of teachers which could produce visible results is preferable to somewhat superficial activities with a large number of teachers. Intensive work and successful modification would serve as an incentive to other teachers to participate in such work.

The Involvement of University Consultant and Local Personnel

Most of the activities in this study were designed to be carried out by the researchers. It was planned, however, that some activities, such as experimentation with the operation of equipment and self-taping for self-analysis, would be executed by teachers without the direct involvement of project staff.

Experience in this project has shown that most teachers were not ready to pursue such activities on their own. Equipment left in schools often was not used for several days. It was necessary to inform participants of the high cost of the equipment and staff and the need to intensify activities so that staff and equipment could be used to the maximum. However, incomplete taping activities at times necessitated the cancellation of visits by the research staff.

At present, most projects dealing with the use of video recordings and micro-teaching techniques in in-service education are in the research stage and are directed by university and research institute personnel. The availability of such personnel is limited and costly. The most logical solution to this problem would be the use of these media and techniques by local school personnel. During the initial stages of the program educational consultants should be available to aid in setting up procedures.

Local school personnel should be assigned to engage in these activities as part of their school load. The actual time needed would depend upon the range of activities. This should, however, be determined before the project begins.

There is need for special training of personnel to administer the activities in each school. The operation of equipment is not complicated and presents few difficulties. Those responsible for the in-service program must be able to motivate teachers to participate in self-improvement activities and to help them in this process through the review of tapes and micro-teaching practices. Such personnel would have to be sensitized to teaching problems and modification of teaching behavior, training in introspection is also essential.

The real problem, however, is to get faculty to accept one of their colleagues for critiquing their tapes and directing behavior modification. Those who administer local in-service training programs are aware that "there is no prophet in his own town." Teachers, in general, prefer "outsiders" to their own colleagues as lecturers and consultants on general educational problems. It is, therefore, safe to assume that they would also have strong

feelings when concerned with the review of tapes of themselves and advice in the modification of their behavior. Although a colleague might be successful in persuading teachers to attend a lecture or a workshop, he might find it difficult to stimulate teachers who try to avoid being taped.

School personnel selected to conduct activities using video recordings and micro-teaching techniques should be known for the quality of their teaching. They should be sensitive to problems of human relations and accepted by their colleagues as individuals with whom one can confide.

Student Feedback

In the Stanford micro-teaching clinic model, after each micro-lesson, an analysis is made based on the video feedback, student feedback, and the supervisor's evaluation. Feedback from the learners is obtained on a special evaluation form.

In the present study, students were asked to use University of Illinois general evaluation instruments designed to evaluate instructors, not specific courses. With the parallel student teaching study, learners in regular classes evaluated student teachers using the evaluation form designed by the Illinois Teaching Techniques Laboratory. This form was designed to evaluate a specific micro-lesson (see Appendix) and was used in a similar project in the College of Engineering.

The use of evaluation forms for each lesson seems to augment the video feedback. Students' favorable reactions toward the teacher's involvement in project activities were evident in their readiness to provide feedback. In many cases, student feedback reinforced the teacher's judgment of the weak and strong points of his lesson.

The Illinois Teaching Techniques Laboratory form does not evaluate competency in a specific teaching skill, such as questioning technique, demonstration, the use of audio-video aids, etc. In some cases in the present studies, a form which evaluates specific teaching skills was used. It has been found that reference to a specific skill is more meaningful to the teacher in motivating change.

It is highly advisable that evaluation forms be analyzed quantitatively. Learner feedback should be recorded in a cumulative form so that the teacher involved can observe and analyze his progress during the activities. This record and the collection of tapes will enable the teacher to see his rate of progress.

A Micro-Teaching Clinic

One possibility, which was not explored in this study but was investigated in a similar study^{17/} is the establishment of a micro-teaching clinic in a school which would employ small groups of students as learners and involve teachers in a more intensive experimentation of teaching strategies and skills.

It is advisable that while teaching in the clinic, the instructor should teach students other than those he has in his regular classes. When student learners are paid, the establishment of a micro-teaching clinic would add to the expense of the activity; however, the value of these experiences seems to justify the additional cost.

Taping Procedures and Techniques

Teachers participating in project activities should be trained to operate the equipment and be expected to operate recorders in the review of tapes. They may desire to tape themselves in the classroom or in role-playing situations without outside help. At times the absence of a technician may require them to be in charge of taping in order to keep on schedule. As a rule, however, teachers should be free from responsibility of taping activities.

In various instances in this study, because of lack of trained student help and the heavy load of those in charge of taping, equipment was set up by a technician but was operated by a student of the class. The recorder was situated near him in the back of the classroom. This procedure solved the problem caused by the shortage of trained student employees. Another reason for the use of students in the class as operators relates to the way teachers perceive the person taping their lesson.

An operator (a colleague or paid student employee) introduces a "foreign element" into the classroom. Teachers may be apprehensive, not only in the presence of colleagues but also in the presence of student operators who may report to administrators events in the classroom. It has been mentioned that teachers had the option of erasing the tape. The possibility of "live messages" from the operator to his superiors in charge of the program cancels the effect of the erasing option.

On the other hand, when regular students in the classroom were assigned to control the recorder, it was difficult to expect them to do so effectively while being attentive to the teacher and the lesson. In some of these cases,

^{17/} Perlberg, A. and O'Bryant, D. C. Video Recordings and Micro-Teaching Techniques to Improve Engineering Instruction, College of Engineering, University of Illinois. Unpublished paper, 1968.

the recording quality of the tape suffered. Moreover, the quality of the content aspects of the tape were impaired. There are many episodes in classroom interaction which may happen in all corners of the classroom and require one to direct the camera and control the audio volume in order to record them. This requires that the operator will be attentive and sensitive to the classroom interaction and will not be concerned with the content of the lesson.

Conducting taping activities without an operator puts a heavy burden on the teacher. Concern about the equipment and its smooth operation makes the teacher more nervous than he would ordinarily be. In several cases, teachers were surprised and frustrated when they discovered in the review session that nothing had been taped because they had not completed the necessary operations.

When cameras are set up in a fixed position without an operator, the teacher movement is restricted to a certain area. In one case, the teacher set the cameras and moved around the class in such a way that he was taped only a few seconds during a whole lesson, even though his voice was recorded. Whether this was accidental or an unconscious attempt to avoid taping should be explored.

In conclusion, even though the teacher should be able to operate the equipment, he should not be burdened with this responsibility. It is essential to indicate to a participating teacher that only in exceptional cases will a taping session be cancelled. He should be assured that when he comes to the classroom, equipment will be there, set up and tested by an operator. He should not have to be concerned about his movement in class. Equipment and cords should be arranged in a way that will not interfere with his or students' movements. Maximum efforts should be made to allow him to be as relaxed as he can be in front of a television camera.

CHAPTER IV

VIDEO TAPE RECORDING SYSTEMS: TECHNICAL ASPECTS

The use of media in education is generally considered a means to an end and is viewed as having a secondary role. In this study, however, the media, portable video tape recordings, played a major role in achieving the purposes of the study. The feedback process facilitated by the media was essential not only for the analysis of teaching behavior but also in stimulating teacher awareness and readiness for change. McLuhan's concept that the 'medium is the message'^{18/} was apparent in the case of this study.

The success of any study on the use of new media in education depends to a great extent on its proper functioning. This was particularly important in activities designed to modify teaching behavior. Technical difficulties which prevent taping of a highly motivated teacher who is ready to confront himself can cause frustration. Recordings of poor quality and distorted images discourage further participation. Adequate attention must be given therefore to assure the proper functioning of media.

Fears of teachers (especially women) about handling mechanical and electronic equipment act as a deterrent to the intensive use of new media in education. Teachers may be anxious about the use of video recorders which are more expensive than other audio-visual equipment in the school. It should be stated emphatically that the average teacher can set up and operate the video recording equipment successfully after he has received proper training and step-by-step written directions. During the span of entire Project (in-service and student teaching investigations) equipment was set up and operated by both men and women. During the in-service study, seven teachers participated and the equipment was transported many times between Champaign, Danville and Decatur. The "down time" for the equipment for the entire Project was only three days with a minimum cost for repairs.

In the following discussion, attention will be given to the technical aspects of the Project's work including the equipment used, a description of the housing units, supplies, maintenance, equipment positioning in the classroom and lab, and camera techniques. The remainder of this chapter will deal with the training of operators, problems arising through misuse of the equipment, and the making of model tapes through the process known as "dubbing."

^{18/} Barnow, Erik. "McLuhanism Reconsidered," Saturday Review, July 23, 1966, p. 19.

Equipment

Each of the two sets of one-half-inch tape equipment used in this investigation included the following:

1. Two cameras
2. Two stand-type microphones
3. One lavalier microphone
4. One 9" television monitor
5. One video recorder
6. One amplifier-mixer
7. Two camera tripods
8. Two microphone stands with bases
9. Two sets of cords

Shortly after the Project began, two items were added to improve the quality of the tapes and to be used with either set:

1. One zoom lens
2. One wide-angle lens

Movable Equipment Housings

The original plan called for two identical sets in operation, each housed in the same type of portable unit. Because of the feasibility nature of the Project, however, it was decided that only one of the planned units would be built and it would contain all of the equipment listed above. This unit required the use of a station wagon; therefore, the second housing was planned to be transported in a standard automobile. This smaller unit contained everything the larger one had with the exception of the amplifier-mixer which serves to amplify and control the sound from more than one microphone at a time. A special "Y-tap" was made for the smaller set to allow two or more microphones to be used simultaneously. With the smaller set, therefore, there is no increase in volume other than that provided by the recorder itself, nor is there individual control of the two microphones.

Early in the investigation, a survey of commercial portable units revealed that none were available that would satisfy the requirements determined by the staff. The unit should be

1. self-contained and requiring only a source of 110 volts,
2. compact,
3. capable of being transported by means of a typical car or station wagon,
4. as lightweight as possible,
5. durable,

6. capable of being locked,
7. convenient in use by a standing operator,
8. designed to store equipment and supplies safely in normal highway travel,
9. easily moved when it arrived at a school, and
10. a welcome addition to a classroom or lab in terms of its overall appearance.

As shown in the Appendix, the original unit, called the "Mobile Video Center," incorporates most, if not all, of these specifications. Several things should be noted with regard to this housing:

1. The top half lifts off so that the two halves are slid into a station wagon in their upright position.
2. To prevent rolling on the casters in transit, $\frac{1}{4}$ " steel pins lock the two stationary casters.
3. In transit the two halves are locked together with trunk catches.
4. The head of one of the camera tripods was removed and mounted in one corner of the unit. It has its full range of elevatability.
5. A single key unlocks all doors.

In the case of the smaller, suitcase-like housing, only the recorder remains outside. When brought to a school, this unit requires some type of convenient-height horizontal surface usually found in a school's projector stand, a bench, or a cafeteria cart.

Essential in the operation of a program involving portable video equipment are two elements. First, well-developed operating instructions must accompany the equipment and must be used faithfully. The present versions found in the Appendix are the result of many revisions and have proven to be near-foolproof when used by anyone who is not colorblind. This leads into the second element, namely, that all wire connecting done by the operator is simply a matter of following color coding of the parts to be joined. The original video tape equipment is not color coded but it is easy and very time-and-trouble saving to use colors to direct the operator.

Supplies

Supplies for the successful operating of the equipment are minimal except for the first item below:

1. Video tapes.
2. Head cleaning fluid.
3. Splicing tape.

As to the price of video tapes, a standard $\frac{1}{2}$ " tape costs approximately \$40 and will provide roughly 55 minutes of playing time. In any new taping the previous recorded image is automatically erased and can be used countless times with a life expectancy, according to one manufacturer, of seven to ten years.

The head cleaning fluid and splicing tape (similar to the short pieces used with audio tapes) are provided in a small carton as part of the set.

Maintenance

Common maintenance of the equipment is relatively simple and can be performed by anyone who has a copy of the manufacturer's manual. Persons responsible for the equipment should be well acquainted with the directions in the manual and act accordingly.

There is, of course, at times, the need for the services of a trained technician in matters of adjustment and even repair if a component is damaged. If such a person is not available, the set must be returned to the manufacturer or his service representative.

Regarding cleaning of the head, the necessary materials are found in the supplies provided by the manufacturer. The manual indicates the proper procedure.

Camera lenses should be cleaned occasionally with readily-available lens tissue.

Guidelines for Setting Up and Operating Equipment in the School

There are many possibilities for the locating of equipment in the classroom or laboratory depending on such factors as the size of the class, the number of cameras and microphones to be used and external conditions such as distracting noises and strong natural light.

Ideally, the taping procedure should not influence the learning environment in any way. To help in achieving this, some guidelines have been developed by the Project staff regarding the locating and operating of equipment.

1. Positioning of Cameras. The center of the video taping operation (where the recorder, monitor, and No. 1 camera are located), should be typically in the back of the classroom at one side. This camera is used chiefly to pick up the instructor although it can be rotated to record student reactions also. Its effectiveness is increased if a zoom lens is mounted on it. If there is intense light coming through windows, the center should be located on the window side. If windows are no problem (as discovered in a trial setup), positioning the camera on the students' right side away from the windows provides better pick-up of most right-handed instructors at the chalkboard.

In Project activities, the No. 2 camera, without an operator, was usually placed in a front corner of the classroom to record the students. With a typical class, the wide-angle lens improved the coverage resulting, of course, in a smaller picture of each student. A switch on the recorder that is controlled by the operator determines which camera is being recorded on the tape.

2. Positioning of Microphones. The use of two or three microphones is recommended to provide adequate sound recording. Stand microphones used in the Project were not directional so one was usually placed in the first or second row of students and aimed at the rear of the group. This microphone plus the lavalier microphone used by the instructor provided relatively satisfactory sound pick-up in the typical situation. Three microphones were used with the Mobile Video Center under more difficult circumstances. It was found that placing a microphone close to students can cause a distraction in some classes.

Recording the audio part of interaction between students and teachers in regular classroom conditions has always been and remains a difficult problem. The instructor who knows how to project his voice has a lavalier microphone which picks up his comments very well. The real problem is in recording the student responses with just two microphones, especially when some students fail to project well. There is even greater difficulty with adverse acoustical conditions. More sensitive microphones are being developed constantly and their possibilities should be explored for improved pick-up of student-teacher interaction.

3. Classroom Arrangement. In a classroom situation, chairs can sometimes be arranged to avoid students blocking out other students. To obtain better quality in the taping of chalkboard work, it is important to have as clean a board as is possible. Soft chalk (preferably yellow) is recommended.

Taping of a demonstration at a piece of equipment such as a milling machine can be difficult because of the tendency of students to crowd in. One method that may help would be to keep a clear view of the instructor by moving in a few chairs or some low objects between him and the camera. Another possible solution

would be to place the camera tripod on a nearby bench for a high angle shot (with a zoom lens for better pick-up) if this is not too distracting to the students.

4. Camera Technique. Good camera technique includes
 - a. keeping the focal point "on camera,"
 - b. smooth, slow movement except in unusual circumstances,
 - c. allowing the picture enough time to be understood by the viewer,
 - d. anticipating what is coming up so that it is accurately recorded (as in the case of a student with a question),
 - e. skilled use of the zoom lens, and
 - f. stopping down the lens (increasing the "contrast") for better chalkboard taping.

Problems Due to Improper Use of Equipment

Basically, the few technical difficulties encountered with the equipment after the housing units were built were caused by operators who failed to follow the instructions. In one case, a camera was tipped over by a student who accidentally caught his foot on a poorly placed cable. In another instance, an electronics teacher tried to repair the equipment and soldered a loose wire to the wrong terminal resulting in a direct short. A recorder was also damaged by the operator who moved the "Play-Stop-Rewind" lever from "Rewind" directly to "Play" without letting the machine come to a complete stop. This resulted in the jamming of the machine when the tape became entangled in the revolving portion known as the "head." These three mishaps were the only ones of any significance that developed during the operation of the Project.

Factors to Consider Before Purchasing Equipment

In considering the purchase of nonprofessional portable video recorders one can choose either a one-half-inch or a one-inch machine. The experience of the project staff in this study and in a similar study conducted in the University of Illinois College of Engineering leads to the conclusion that recent models of half-inch equipment are very adequate in their performance.

Not only did this size serve well in the everyday taping and reviewing but also proved very effective in dubbing procedures and as the source of feeding 24-inch monitors. The latter was done in several presentations to groups of 50 to 100 people.

The cost of a video taping set of equipment can vary considerably depending on size, the type of equipment, and the accessories needed. The simplest combination, which includes one camera, one microphone and no amplifier-mixer

would list at approximately \$1,200. The price of each set used in project activities was roughly \$2,800. This did not include the zoom lens for \$350, nor the wide-angle lens at \$75.

In addition to these special lenses, which were found to be very helpful, the equipment buyer should give consideration to a set of accessories which would allow the instructor and a student or group of students to be picked up from two cameras simultaneously. This is known as "split-screen operation" and requires an additional investment of approximately \$1,200 for a sync generator and special effects generator. Just as the split screen used in televising sports events proves valuable, it would appear that it would have value in classroom taping especially when the major concern is feedback through nonverbal clues or student reactions to the instructor's activities.

One of the factors to consider before purchasing equipment is its compatibility (i.e., the ability to play back tapes recorded on two different machines made by one company). All manufacturers claim that their equipment is compatible; however, there is a great deal of difference between advertising and actual performance. Few, if any, half-inch VTR's have 100 percent compatibility. The wider the tape, the more the likelihood of compatibility. Regarding this point it should be mentioned that a qualified technician can adjust several sets to make them more compatible. In the case of the project's activities, this was done and the results were very acceptable.

With the value of video taping equipment in teacher education becoming more and more apparent, manufacturers have greatly increased production. They are still unable to satisfy the demand, however, particularly when immediate delivery is requested.

Training In-Service Education Personnel in Technical Aspects

As indicated earlier in this report, project researchers conducted most of the activities. This would include the bulk of the actual taping, although some was done by participating personnel who attended the orientation workshop at the University. Later, in their own institutions, additional practice in setting up and operating the equipment was provided. Experience of this nature should include typical setups followed by problems involving special arrangements as, for example, the taping of a demonstration at a machine or a lecture in which small objects are introduced to the class.

Preparation of Model Tapes

In any video taping operation there is a greater amount of latitude and flexibility if selected portions from various tapes can be combined on one

tape. This is particularly true in the case of the preparation of "model tapes" which are instructional tapes designed to show exemplary performance in a classroom.

Although it is true that tapes can be spliced, this often is a poor solution to the problem for two reasons. First, the mechanical fusing of two or more tapes is not as dependable as a single tape without any breaks. Secondly, the original tapes are no longer intact and complete; thus, their further use is limited.

A better procedure for making model tapes is the system known in the field as "dubbing" or the preparation of a new recording from several other tapes with no change in the original tapes. In this process the recorder on which the dubbing is done must be compatible with the machines used in making the original tapes. In view of the fact that even some video tape technicians doubt that dubbing of half-inch tape can be done, a method developed by the project's staff member responsible for the equipment is presented in the Appendix.

In the developing of model tapes, captioning to identify the various parts of a tape can be very effective. For the model tapes made by the project staff, captions were made simply by video taping the titles made up of self-adhesive white ceramic letters fastened to the dark surface on the back of the Mobile Video Center.

Viewers of television news broadcasts are familiar with a "voice override" even though they may not be aware of the accepted term for this technique. When the volume of a tape recording of a news story is lowered and the news reporter comments at the normal level of sound, this is known as a "voice override." This method can be used effectively in the preparation of model tapes when the procedures found in the Appendix are followed.

CHAPTER V

CONCLUSIONS AND RECOMMENDATIONS

The following conclusions and recommendations are presented in the chronological order of project activities. This order does not indicate their relative importance.

Orientation Program

Effective orientation of administrators and faculty in local school systems to the potential and procedures of utilizing video tape recorders and micro-teaching techniques in in-service education programs must precede any research or activities in this area. This orientation should serve to relieve the faculty of anxieties inherent in the media and to select for initial work those who would be willing to work intensively and stimulate others by their personal example to pursue similar work.

University Consultants and Local Personnel

The availability of university personnel to conduct in-service education programs is limited; moreover, when consultants are involved, it adds significantly to the budget of such programs. It is essential, therefore, to train local school personnel to assume the responsibility of organizing and conducting in-service education programs utilizing VTR's and MTT's. Personnel in charge of such programs should be given adequate time, facilities and incentives to pursue such work.

University Orientation Workshop

University workshops to introduce school personnel responsible for in-service education to the use of MTT's, their theoretical background, and the operation of video recorders, should be conducted before the beginning of any program. Participants should be then able to organize and conduct in-service education programs utilizing MTT's and VTR's on their own with assistance from the university consultant. The university should offer such workshops for credit.

Conditions for the Utilization of VTR's and MTT's

Several conditions are essential for the effective use of VTR's and MTT's in in-service education programs. A nonthreatening, permissive atmosphere should prevail; the faculty should be assured that tapes will not be used by administrators against them. They should be the first to view the tapes and be able to erase them if they desire. Participants should be released from some of their school activities to enable them to be engaged in intensive work. Teaching assignments should be coordinated to allow for immediate analysis of tapes. It is also important that schools purchase equipment to conduct these activities.

Student Feedback and the Micro-Teaching Clinic

A review of the literature and experiences in this study indicates the importance of written student feedback in the analysis of tapes. In addition to a general evaluation of the teacher's lesson, questionnaires should focus on specific teaching skills. It is, therefore, recommended that this practice be used extensively.

It is suggested that a micro-teaching clinic be established in the schools for teachers experimenting in various types of classroom interaction and teaching skills.

Taping Procedure and Techniques

Every teacher involved in taping activities should know how to operate the equipment, particularly when viewing his tapes. He should not, however, be burdened with the responsibility and tasks of taping his classes. Technicians or trained student employees should be assigned to this duty.

Cancellation of taping activities at the last minute or unsuccessful taping has caused frustration, reluctance to participate in such activities and even some cases caused some to drop out from the program. Maximum efforts should be made to tape teachers when they are scheduled and special care should be given to assure that the taping is successful. It is essential that disturbance due to technical problems be kept at a minimum.

Encouraging Participation in Programs Utilizing VTR's and MTT's

A supportive atmosphere is essential for any in-service education program. This is more so true with a program that may be perceived as threatening. VTR's and MTT's, more than many other methods, have the potential of modifying teacher behavior and improving the educational process. Incentives to encourage participation in such programs should be provided.

Custom-Built Housings for Equipment

To safely transport equipment and for its efficient use, it is essential that well-designed housing units be provided (custom-built or commercially available). Illustrated instructions should accompany each unit and must be followed faithfully. Color coding of electrical connections should be done to assist the operator.

The Selection of Equipment

Because of performance, size, weight, and cost, the half-inch size of VTR should be given serious consideration by anyone contemplating the purchase of equipment for video taping in an in-service education program.

Equipment Scheduling

A well-planned schedule for the transporting of equipment should be completed far in advance. Such a schedule should route the units to the equipment center for the weekends to permit adjustment and maintenance.

BIBLIOGRAPHY

- Alexander, L.T., Kepner, C.H., and Tregoe, B.B. "The Effectiveness of Knowledge of Results in a Military System Training Program," Journal of Applied Psychology, Vol. 46, No. 3, June, 1962, pp. 202-211.
- Alexander, L.T. and others. A Demonstration of the Use of Simulation in the Training of School Administrators. New York: Office of Research and Evaluation, Division of Teacher Education, City University of New York, 1967.
- Allen, D.W. "A New Design for Teacher Education: The Teacher Intern Program At Stanford University," Journal of Teacher Education, Vol. 17, No. 3, 1966, pp. 296-300.
- Allen, D.W. Micro-Teaching: A Description. Stanford, California: Stanford University, School of Education, 1966.
- Allen, D.W. "Micro-Teaching: A New Framework for In-service Education," High School Journal, Vol. 49, May, 1966, pp. 355-362.
- Allen, D.W. "New Dimensions in Trade and Technical Teacher Education," American Vocational Teacher Journal, Vol. 41, September, 1966, pp. 20-22.
- Allen, D.W. and others. A Comparison of Different Modeling Procedures in the Acquisition of a Teaching Skill. Stanford University. Unpublished paper presented at the American Educational Research Association Convention, Chicago, February, 1968.
- Allen, D.W. and Fortune, F.C. An Analysis of Micro-Teaching: A New Procedure in Teacher Education. Unpublished paper presented at the American Educational Research Association Convention, Chicago, February, 1968.
- Allen, D.W. and Gross, R.E. "Micro-Teaching - A New Beginning for Beginners," NEA Journal, Vol. 55, No. 9, December, 1965, pp. 25-26.
- Allen, D.W. and Ryan, K.A. A New Face for Supervision. Unpublished paper prepared for use in the 1965-1966 Regional TEPS Conferences.
- Allen, D.W. and Young, D. Television Recordings - A New Dimension in Teacher Education. Stanford University. Unpublished mimeographed paper.
- Amidon, E.J. "Interaction Analysis and Its Application to Student Teaching," Theoretical Bases for Professional Laboratory Experiences in Teacher Education. Forty-fourth Yearbook. Cedar Falls, Iowa: Association for Student Teaching, 1965.
- Amidon, E.J. Using Interaction Analysis at Temple University. Paper read at the Conference on the Implications of Recent Research on Teaching for Teacher Education, sponsored by the National Association for Student Teaching and the University of Rochester, Rochester, New York, January, 1966.
- Amidon, E.J. and Amidon, P. Interaction Analysis Training Kit: Level I. Minneapolis: Association for Productive Teaching, 1967.

- Amidon, E.J. and Amidon, P. Interaction Analysis Training Kit: Level II. Minneapolis: Association for Productive Teaching, 1967.
- Amidon, E.J. and Amidon, P. Teaching Pattern Analysis. Minneapolis: Association for Productive Teaching, 1967.
- Amidon, E.J. and Flanders, N. "Interaction Analysis As A Feedback System," Interaction Analysis: Research, Theory and Application. E.J. Amidon and J.B. Hough (eds.). Boston: Addison-Wesley, 1967, pp. 121-140.
- Amidon, E.J. and Flanders, N. The Role of the Teacher in the Classroom: A Manual for Understanding and Improving Teachers' Classroom Behavior. Minneapolis: Paul S. Amidon Associates, 1967.
- Amidon, E.J. and Giammatteo, M.C. "The Behavior of Superior Teachers," The Elementary School Journal, Vol. 65, February, 1965, pp. 283-285.
- Amidon, E.J. and Hough, J.B. (eds.) Interaction Analysis: Research, Theory and Application. Boston: Addison-Wesley, 1967.
- Amidon, E.J. and Hunter, E. Improving Teaching: Analyzing Verbal Interaction in the Classroom. New York: Holt, Rinehart, and Winston, 1966.
- Amidon, E.J. and Hunter, E. Improving Teaching: The Analysis of Classroom Instruction. New York: Holt, Rinehart, and Winston, 1966.
- Amidon, E.J. and Hunter, E. "Interaction Analysis: Recent Developments," Interaction Analysis: Research, Theory and Application. E.J. Amidon and J.B. Hough (eds.). Boston: Addison-Wesley, 1967, pp. 388-392.
- Amidon, E.J. and Hunter, E. "Verbal Interaction in the Classroom," Professional Reprints in Education, No. 8605. Columbus, Ohio: Charles E. Merrill Books, 1966.
- Amidon, E.J., Kies, K., and Palis, A. "A Fresh Look at Supervision," The National Elementary Principal, Vol. 45, April, 1966, pp. 54-59.
- Amidon, E.J. and Powell, E.R. Interaction Analysis as a Feedback System in Teacher Preparation. Paper read at the Association for Supervision and Curriculum Development, Curriculum Research Institute, Washington, D.C., November, 1965.
- Amidon, E.J. and Rosenshine, B. Interaction Analysis and Microteaching in An Urban Teacher Education Program - A Model for Skill Development in Teaching. Temple University. Unpublished paper presented at the American Educational Research Association Convention, Chicago, February, 1968.
- Amidon, E.J. and Simon, A. Implications for Teacher Education of Interaction Analysis Research in Student Teaching. Paper read as part of a symposium on interaction analysis and its application to student teaching, American Educational Research Association Convention, Chicago, February, 1965.
- Amidon, E.J. and Simon, A. "Teacher-Pupil Interaction," Review of Educational Research, Vol. 35, April, 1965, pp. 130-139.

Amidon, E.J., Weber, W.A. and Powell, E.R. Integration of the Dimensions of a Number of Category Systems into a Single-Category System: An Application to Children in Deprived Schools. Temple University, Syracuse University, University of Georgia. Unpublished paper presented at the American Educational Research Association Convention, Chicago, February, 1968.

Amidon, E.J. and others. "Interaction Analysis and Its Application to Student Teaching," Association for Student Teaching Yearbook. Dubuque, Iowa: William C. Brown Co., 1965.

Amidon, E.J. and others. Project on Student Teaching: The Effects of Teaching Interaction Analysis to Student Teachers. United States Department of Health, Education, and Welfare, Office of Education, Cooperative Research Project No. 2873. Philadelphia: Temple University, 1967.

Andrews, L.O. A Curriculum to Produce Career Teachers for the 1980's. Ohio State University. Unpublished mimeographed paper, 1967.

Aubertine, H.E. The Use of Micro-Teaching in the Process of Training Clinical Supervisors. Arizona State University. Unpublished mimeographed paper presented at the American Educational Research Association Convention, Chicago, February, 1967.

Baird, J.H., Belt, W.D. and Webb, C.D. Micro-Teaching at Brigham Young University. Brigham Young University, School of Education. Unpublished mimeographed paper.

Barnow, Erik. "McLuhanism Reconsidered," Saturday Review, Vol. 49, No. 30, July 23, 1966, pp. 19-23.

Bellack, A. and others. The Language of the Classroom. New York: Bureau of Publications, Teachers College, Columbia University, 1967.

Belt, W.D. and Holder, L.E. Continuous Progress in the Training of Secondary Teachers at B.Y.U.: Content and Rationale. Brigham Young University. Unpublished paper presented at the American Educational Research Association Convention, Chicago, February, 1968.

Belt, W.D. and Webb, C.D. "Micro-Teaching at Brigham Young University," Utah Educational Review, Vol. 61, No. 1, September-October, 1967, p. 18.

Binnington, G.H. Self-Acceptance Changes in Student Teachers as A Result of Student-Centered University Supervision. University of Oregon, Eugene. Unpublished doctoral dissertation, 1965.

Bloom, B.S. "The Thought Process of Students in Discussion," Accent on Teaching: Experiments in General Education. S.J. French (ed.). New York: Harper and Brothers, 1954.

Borg, W.R. The Minicourse: Rationale and Uses in the Inservice Education of Teachers. Unpublished paper delivered at the American Educational Research Association Convention, Chicago, February, 1968.

Bridle, B.J. "The Integration of Teacher Effectiveness Research," Contemporary Research on Teacher Effectiveness. New York: Holt, Rinehart, and Winston, 1964, pp. 1-40.

- Brown, A.B., Coban, M.E., and Waterman, F.T. An Analysis of Verbal Teaching Behavior, An Approach to Supervisory Conferences with Student Teachers. Teachers College, Columbia University. Unpublished doctoral dissertation, 1965.
- Bush, R.N. and Allen, D.W. Micro-Teaching - Controlled Practice in the Training of Teachers. Unpublished paper presented at the Santa Barbara Conference on Teacher Education of the Ford Foundation, 1964.
- Coffey, H.S. and Golden, W.P., Jr. "Psychology of Change Within An Institution," In-Service Education for Teachers, Supervisors, and Administrators. N.B. Henry (ed.). The Fifty-sixth Yearbook of the National Society for the Study of Education. Chicago: The University of Chicago Press, 1957, p. 67.
- Conant, J.B. The Education of American Teachers. New York: McGraw-Hill, 1963.
- Cooper, J.M. Developing Specific Teaching Skills Through Micro-Teaching. Stanford University. Unpublished paper.
- Corey, S.M. "Introduction," In-Service Education for Teachers, Supervisors, and Administrators. N.B. Henry (ed.). The Fifty-sixth Yearbook of the National Society for the Study of Education. Chicago: The University of Chicago Press, 1957, pp. 2-3.
- Dalton, R.E. A Comparative Appraisal of Supervising Teacher and Student Teacher Performance as an Evaluation Technique in Student Teaching Programs. Purdue University. Unpublished doctoral dissertation, 1965.
- Daniels, L. Teacher Perceptions on the Role of a Teacher. University of California, Los Angeles. Unpublished master's thesis, 1964.
- Drumheller, S.J. and Paris, J. "An Effective Approach for Incorporating Teaching Experiences in Methods Courses," Journal of Teacher Education, Vol. 18, No. 3, 1966, pp. 290-295.
- Elliott, R.J. Changes in Openness of Student Teachers as a Function of Openness of Supervising and Cooperating Teachers. University of Alabama. Unpublished doctoral dissertation, 1965.
- Flanders, N.A. "Intent, Action, and Feedback: A Preparation for Teaching," Interaction Analysis: Research, Theory and Application. E.J. Amidon and J.B. Hough (eds.). Boston: Addison-Wesley, 1967, pp. 283-294.
- Flanders, N.A. "The Problems of Observer Training and Reliability," Interaction Analysis: Research, Theory and Application. E.J. Amidon and J.B. Hough (eds.). Boston: Addison-Wesley, Inc., 1967, pp. 158-166.
- Flanders, N.A. "Some Relationships Among Teacher Influence, Pupil Attitudes," Interaction Analysis: Research, Theory and Application. E.J. Amidon and J.B. Hough (eds.). Boston: Addison-Wesley, Inc., 1967, pp. 217-242.
- Flanders, N.A. "Teacher Behavior and In-Service Programs," Interaction Analysis: Research, Theory and Application. E.J. Amidon and J.B. Hough (eds.). Boston: Addison-Wesley, Inc., 1967, pp. 256-261.
- Fortune, J.C., Cooper, J.M., and Allen, D.W. The Stanford Summer Micro-Teaching Clinic, 1965. Stanford University. Unpublished paper, 1965.

- Foster, F.G. "Micro-Teaching," Arizona Teacher, Vol. 55, May, 1967, pp. 12-13.
- Friedman, N.L. "Instant Playback in the Shop," Industrial Arts and Vocational Education, Vol. 57, January, 1968, pp. 34-35.
- Furst, N. The Effects of Training in Interaction Analysis on the Behavior of Student Teachers in Secondary Schools. Paper read at the American Educational Research Association Convention, Chicago, February, 1965.
- Furst, N. and Amidon, E.J. Teacher-Pupil Interaction Patterns in the Elementary School. Paper read at Schoolmen's Week, University of Pennsylvania, Philadelphia, 1962.
- Gallagher, J. and others. A System of Topic Classification Classroom Interaction Study. Institute for Research on Exceptional Children, University of Illinois. Mimeographed paper, 1966.
- Gallagher, J. A Topic Classification System for Interaction Analysis. U.S. Office of Education. Unpublished paper presented at the American Educational Research Association Convention, Chicago, February, 1968.
- Goodkind, T.B. An Evaluation of the Effectiveness of the Micro-Teaching Technique in the Training of Elementary School Teachers. University of Connecticut. Unpublished paper presented at the American Educational Research Association Convention, Chicago, February, 1968.
- Hill, R.A. Systems Analysis of Teaching: An R & D Model. Temple University. Unpublished paper presented at the American Educational Research Association Convention, Chicago, February, 1968.
- Hill, R.A. and Medley, D.M. Change in Behaviors of First Year Intern Teachers. Temple University, Educational Testing Services. Unpublished paper presented at the American Educational Research Association Convention, Chicago, February, 1968.
- Honigman, F.K. A Three-Dimensional System for Analyzing Teacher-Pupil Interaction in the Classroom. Franklin Institute. Unpublished paper presented at the American Educational Research Association Convention, Chicago, February, 1968.
- Honigman, F.K. Innovations and Revisions to the Flanders System of Interaction Analysis. Temple University. Mimeographed paper, 1964.
- Honigman, F.K. Multidimensional Analysis of Classroom Interaction (MACI). Villanova, Pennsylvania: The Villanova University Press, 1967.
- Hough, J.B. "Classroom Interaction and the Facilitation of Learning: The Source of Instructional Theory," Interaction Analysis: Research, Theory and Application. E.J. Amidon and J.B. Hough (eds.). Boston: Addison-Wesley, Inc., 1967, pp. 375-387.
- Hough, J.B. "An Observation System For the Analysis of Classroom Instruction," Interaction Analysis: Research, Theory and Application. E.J. Amidon and J.B. Hough (eds.). Boston: Addison-Wesley, Inc., 1967, pp. 150-157.

- Hough, J. B. A Study of the Effect of Five Experimental Treatments on the Development of Human Relations Skills and Verbal Teaching Behaviors of Pre-Service Teachers. College of Education, Ohio State University. Unpublished paper, 1965.
- Hough, J.B. The Dogmatism Factor in Human Relations Training of Preservice Teachers. Unpublished paper presented at the American Educational Research Association Convention, Chicago, February, 1965.
- Hough, J.B. and Amidon, E.J. Behavioral Change in Pre-Service Teacher Preparation: An Experimental Study. Philadelphia: College of Education, Temple University, 1964.
- Hough, J.B. and Amidon, E.J. "Behavioral Change in Student Teachers," Interaction Analysis: Research, Theory and Application E.J. Amidon and J.B. Hough (eds.). Boston: Addison-Wesley, Inc., 1967, pp. 307-314.
- Hough, J.B. and Ober, P. The Effect of Training in Interaction Analysis on the Verbal Training Behavior of Pre-Service Teachers. Paper presented at the American Educational Research Association Convention, Chicago, February, 1966.
- Howsam, R.B. New Designs for Research in Teacher Education. California Teachers' Association, 1960.
- Hunter, E. and Amidon, E. "Direct Experience in Teacher Education: Innovation and Experimentation," Journal of Teacher Education, Vol. 17, No. 3, Fall, 1966, pp. 282-289.
- Jalbert, E.L. An Investigation to Determine the Effectiveness of Training in the Evaluation of Classroom Instruction as an Aid to Self-Evaluation in Student-Teaching. Syracuse University. Unpublished doctoral dissertation, 1965.
- Joyce, B., Weinstein, G., and Hunt, D. Four-Dimensional Analysis of Teaching. Unpublished paper, 1966.
- Kagan, N., Krathwohl, D. and Farquhar, W. IPR - Interpersonal Process Recall: Stimulated Recall by Videotape. East Lansing, Michigan: Michigan State University, College of Education, Bureau of Education Research Services, Series No. 24, March, 1965.
- Kallenbach, W.W. The Effectiveness of Microteaching in the Preparation of Elementary Intern Teachers. Far West Laboratory for Educational Research and Development. Unpublished paper presented at the American Educational Research Association Convention, Chicago, February, 1968.
- Kallenbach, W.W. "Microteaching as a Teaching Methodology," Proceedings: Conference on Instructional Methods and Teacher Behavior. Berkeley: Far West Laboratory for Educational Research and Development, 1968, pp. 14-19.
- Kersh, B.Y. Classroom Simulation: Further Studies on Dimensions of Realism. Unpublished paper presented at the American Educational Research Association Convention, Chicago, February, 1966.

- Kirk, J. "Elementary School Student Teachers and Interaction Analysis," Interaction Analysis: Research, Theory and Application. E.J. Amidon and J.B. Hough (eds.). Boston: Addison-Wesley, Inc., 1967, pp. 299-306.
- Kirk, J. The Effects of Teaching the Minnesota System of Interaction Analysis on the Behavior of Student Teachers. Temple University. Unpublished doctoral dissertation, 1964.
- LaGrone, H.F. A Proposal for the Revision of the Preservice Professional Component of a Program of Teacher Education. Washington, D.C.: The American Association of Colleges for Teacher Education, 1964.
- LaShier, W.S., Jr. The Use of Interaction Analysis in BSCS Laboratory Block Classrooms. Paper read at the National Science Teachers Association Meetings, New York City, April, 1966.
- Lewin, K. "Conduct Knowledge and Acceptance of New Values," Resolving Social Conflicts. New York: Harper and Brothers, 1948.
- Lewin, K. and Grabbe, P. "Problems in Re-education," Journal of Social Issues, Vol. 1, No. 3, August, 1965, pp. 53-64.
- Maccoby, N. and others. Sound Film Recordings in Improving Classroom Communication. A report submitted to the U.S. Office of Education, Title VII, Project 680. Stanford, California: Institute for Communication Research, Stanford University, 1965.
- Maier, N.R.F. Problem Solving Discussions and Conferences: Leadership Methods and Skills. New York: McGraw-Hill, 1963.
- Medley, D.M. and Hill, R.A. A Comparison of Two Techniques for Analyzing Classroom Behavior. Educational Testing Service, Temple University. Unpublished paper presented at the American Educational Research Association Convention, Chicago, February, 1968.
- Medley, D.M. and Mitzel, H.E. "Measuring Classroom Behavior By Systematic Observation," Handbook of Research on Teaching. N.L. Gage (ed.). Chicago: Rand McNally & Co., 1963, pp. 247-328.
- Meier, J.H. Micro-Counseling - An Interpersonal Sensitization Experience. Psycho-Educational Research Institute. Unpublished paper, 1966.
- Meier, J.H. Microteaching in Small School In-Service Education Programs. Rocky Mountain Regional Education Laboratory. Unpublished paper presented at the American Educational Research Association Convention, Chicago, February, 1968.
- Meier, J.H. NDEA Remote Teacher Training Program in Early Childhood Education. Greeley, Colorado: Child Study Institute, Colorado State College, 1967.
- Meier, J.H. Rationale for and Application of Microteaching to Improve Teaching. Rocky Mountain Regional Education Laboratory. Mimeographed paper, 1968.

- Meier, J.H. and Brudenell, G. Simulated Lesson Analysis Chart (SimuLAC). Greeley, Colorado: NDEA Microteaching Program, Child Study Institute, Colorado State College, 1967.
- Meier, J.H. and Brudenell, G. Interim Progress Report of a Remote Teacher Training Institute for Early Childhood Educators. Child Study Institute, Colorado State College. Unpublished paper presented at the American Educational Research Association Convention, Chicago, February, 1968.
- Merrill, M.D. Training Teachers for Instructional Design - A Problem and A Point of View. Stanford University. Unpublished paper presented at the American Educational Research Association Convention, Chicago, February, 1968.
- Miel, A. Changing the Curriculum - A Social Process. New York Appleton-Century-Crofts, Inc., 1946.
- Miller, G.L. An Investigation of Teaching Behavior and Pupil Thinking. Salt Lake City: Utah State Board of Education Research and Experimentation Funds Section, Agreement Number 4622, 1964.
- Minnis, D. Interaction Analysis and Microteaching Procedures in In-Service Education of Teachers. University of California, Davis. Unpublished paper presented at the American Educational Research Association Convention, Chicago, February, 1968.
- Minnis, D. Micro-Teaching and Interaction Analysis in a Teacher Education Curriculum. University of California, Davis. Unpublished paper presented at the American Educational Research Association Convention, Chicago, February, 1968.
- Moser, J. A Case Study of the Effect of Information Feedback on the Performance of Student Teachers in Mathematics. University Microfilms, Ann Arbor, Michigan, 1965.
- Moskowitz, G. The Effects of Training in Interaction Analysis on the Attitudes and Teaching Patterns of Cooperating Teachers and Their Student Teachers. Temple University. Unpublished doctoral dissertation, 1966.
- Moskowitz, G. "The Attitudes and Teaching Patterns of Cooperating Teachers and Student Teachers Trained in Interaction Analysis," Interaction Analysis: Research, Theory and Application. E.J. Amidon and J.B. Hough (eds.). Boston: Addison-Wesley, Inc., 1967, pp. 271-282.
- McDonald, F.J., Allen, D.W., and Orme, M.E. Effect of Self Evaluation and Social Reinforcement on the Acquisition of a Teaching Behavior. Unpublished paper presented at the American Educational Research Association Convention, Chicago, February, 1966.
- McDonald, F.J., Allen, D.W., and Seidman, E. Televised Models for Teacher Training. Stanford University. Unpublished paper.

- Nelson, L. "Teacher Leadership: An Empirical Approach to Analyzing Teacher Behavior in the Classroom," Classroom Interaction Newsletter, Vol. 2, November, 1966, pp. 31-32.
- Nielson, G. Studies in Self-Confrontation. Copenhagen: Munkegaard, 1962.
- Oliver, D.W. and Shaver, J.P. "A Critique of 'Practice Teaching'," Harvard Educational Review, Vol. 31, No. 4, Fall, 1961, pp. 437-448.
- Olivero, J.L. Video Recordings as a Substitute for Live Observations in Teacher Education. Stanford University. Unpublished doctoral dissertation, 1965.
- Orme, M.E., McDonald, F.J., and Allen, D.W. Effect of Modeling and Feedback Variable on the Acquisition of a Complex Teaching Skill. Stanford University. Unpublished paper presented at the American Educational Research Association Convention, Chicago, February, 1966.
- Pankratz, R. "Verbal Interaction Patterns in the Classroom of Selected Physics Teachers," Interaction Analysis: Research, Theory and Application. E.J. Amidon and J.B. Hough (eds.). Boston: Addison-Wesley, Inc., 1967, pp. 176-185.
- Perlberg, A. An Analysis of Incentives to Stimulate Educators' Growth. Columbia University. Unpublished doctoral dissertation, 1958.
- Perlberg, A. and O'Bryant, D.C. Video Recordings and Micro-Teaching Techniques to Improve Engineering Instruction. College of Engineering, University of Illinois. Unpublished paper, 1968.
- Romney, G. and others. Patterns of Effective Teaching. Provo, Utah: Provo Board of Education, 1961.
- Romoser, R.C. "Change in Attitude and Perception in Teacher Education Students Associated with Instruction in Interaction Analysis," Dissertation Abstracts, Vol. 25, 1965, pp. 57-70.
- Sanders, N.M. Classroom Questions: What Kinds? New York: Harper & Row. 1966.
- Schueler, H., Gold, M., and Mitzel, H. The Use of Television for Improving Teacher Training and for Improving Measures of Student-Teaching Performance: Phase I. Improvement of Student Teaching. New York: Hunter College of the City University of New York, 1962.
- Schueler, H., Lesser, G.S., and Robbins, A.L. Teacher Education and the New Media. Washington, D.C.: American Association of Colleges for Teacher Education, 1967.
- Sedgwick, L.K., and Misfeldt, H.T. "Micro-Teaching - New Tool For a New Program," Industrial Arts and Vocational Education, Vol. 56, No. 6 June, 1967, pp. 34-35.
- Sharp, G. Curriculum Development as Re-Education of the Teacher. New York: Bureau of Publications, Teachers College, Columbia University, 1951.

- Simon, A. The Effects of Training in Interaction Analysis on the Teaching Patterns of Student Teachers in Favored and Non-Favored Classes. Temple University. Unpublished doctoral dissertation, 1966.
- Soar, R. An Integrative Approach to Classroom Learning. Public Health Service, Final Report, No. 7-R11MH02045. Philadelphia: Temple University, 1966.
- Soar, R. "Pupil Needs and Teacher-Pupil Relationships: Experiences Needed for Comprehending Reading," Interaction Analysis: Research, Theory and Application, E.J. Amidon and J.B. Hough (eds.). Boston: Addison-Wesley, 1967, pp. 243-251.
- Sorenson, A.G. "What is Learned in Practice Teaching?" Journal of Teacher Education, Vol. 18, Summer, 1967, pp. 173-178.
- Sorenson, A.G. and Gross, C.F. Teacher Appraisal: A Matching Process. Los Angeles: UCLA CSEIP Occasional Report No. 4, 1967.
- Sorenson, A.G., Husek, T.R., and Yu, C. "Divergent Concepts of Teacher Role: An Approach to the Measurement of Teacher Effectiveness," Journal of Educational Psychology, Vol. 54, 1963, pp. 287-294.
- Springman, D.B. Secondary-Teacher Majors: Classroom Observations By Audio-Video-Tape Devices. Western Reserve University. Unpublished doctoral dissertation, 1965.
- Tucker, C.A. "Video Recordings Implement Teaching," Industrial Arts and Vocational Education, Vol. 56, No. 6, June, 1967, p. 37.
- Twelker, P.A. Simulation Applications in Teacher Education. Oregon State System of Higher Education. Unpublished paper, 1966.
- Voth, J.A. Effect of Video-Tape Recording Feedback on Teaching Behavior of Student Teachers. University of Missouri. Unpublished paper presented at the American Educational Research Association Convention, Chicago, February, 1968.
- Voth, J.A. and others. Helping Student Teachers Change Their Behavior. University of Missouri. Mimeographed paper, 1967.
- Weaver, W.J. "Video-Tape New Life Into Your Recruitment Program," Industrial Arts and Vocational Education, Vol. 56, No. 6, June, 1967, p. 36.
- Webb, C., and Baird, H. A Summary of Selected Research on Micro-Teaching. Brigham Young University. Unpublished paper presented at the Association for Student Teaching, Ogden, Utah, April, 1967.
- Weber, W.A. Teacher and Pupil Creativity. Temple University. Unpublished doctoral dissertation, 1967.
- Wright, D.L. A Study of Various Types of Training and Feedback on the Verbal Behavior and Attitudes of Teachers. Temple University. Unpublished doctoral dissertation, 1967.

Young, D.B. The Effectiveness of Self Instruction in Teacher Education Using Modeling and Video-Tape Feedback. University of Maryland. Unpublished paper presented at the American Educational Research Association Convention, Chicago, February, 1968.

Zahn, R. The Effect of Cooperating Teacher Attitudes on the Attitudes of Student Teachers. Glassboro State College. Unpublished paper.

Zahn, R. The Use of Interaction Analysis in Supervising Student Teachers. Temple University. Unpublished doctoral dissertation, 1965.

APPENDIX A

Excerpts from Teacher Reactions

"Having been an active participant in the micro-teaching project, I am now more aware of my shortcomings and habits. I can certainly realize some of its many merits and I only hope that it continues to be used as a means for individual improvement and not a means by which an administrator can visit a class by proxy. Although I am sure none of the participants would have objected if an administrator had asked to view their tapes.

"I was somewhat displeased in the timing of the taping. Rather than the video-taping fitting into my daily schedule, it was often necessary to rearrange class plans to meet its schedule which was often inconvenient.

"Another regret is that I could not always put the researcher's constructive remarks into practice due to my teaching load (28 contact hours) which necessitated my devoting the bulk of my preparation time to the subjects not previously taught."

"My experience with the Micro-teaching Program has been a very beneficial one. I feel this program has great potential and I would like very much to see it continued in the future.

"After the initial taping, I do not believe the equipment and the operators interfered with the regular class work.

"I was extremely pleased to see both members of my department participate in the project and I know both of them felt it to be profitable.

"Personally, I believe I could have benefited more from the program if I could have had a more intensive amount of taping and reviewing. For example, to tape on two consecutive days when I presented the same lesson two days in a row to each section of the class. The reviewing with the researcher was the most helpful part of the program because he could see ways to improve that I could not. His suggestions were made in a very tactful and helpful manner too."

"The video recorder program was quite effective in my particular case. I enjoyed working with the equipment and the consultant. Through the use of the equipment I discovered that I was doing things that I was not conscious of before. The first time that I used the equipment I was a little nervous; however, after I overcame this I felt the equipment and review sessions were quite beneficial. I would like the opportunity to continue using such equipment for personal improvement."

"The benefits of recording and reviewing such video/audio tapes are both real and valuable. While a professional supervisor reviewing the tapes is probably best in the "micro" situation, the maximum benefit for normal class recordings can be derived by reviews conducted by a contemporary of the teacher who has knowledge of the subject or, at least, the field being taught. My desire to continue using the recording equipment to make self-improvements is a little inhibited by my planned 21-hour contact load for next fall.

"Awareness of the equipment's presence and operation seems to improve the interest of nearly all students in the subject. Only the very poor students seem to lose interest. Whether the seeming interest is accompanied by real learning has not been definitely measured.

"Students seem pleased that the teacher wants to improve himself and that they are a part of the feedback mechanism."

"Micro-Teaching has helped me become more aware of the interaction between the instructor and the student and the many aspects of instructor behavior that affect classroom learning. I feel that this period should be limited to ten minutes, that the half hour or so of recording that was done in my case was more than what was needed. Possibly the first one should be approximately a half hour and the future ones broken down to ten minutes to utilize each period of work on a few specific aspects of the teaching methods. I think that the students also received a benefit in the class from the Hawthorne effect.

"I believe that I have benefitted from this video taping and critiquing. Many of the staff, in my opinion, would be interested in the use of video tape for this purpose with the possibility that they would later on go along with choosing some ten minute portion of the video tape that they would let the administration use for evaluation. I believe that it would only work in this manner. If it were to be set up so that someone in this school were to assist in the video tape critiquing, it is my opinion that it would have to be somebody who is not connected with the administration who has been teaching for a reasonable period and who is respected by his fellow teachers for his discretion."

APPENDIX B1

Equipment

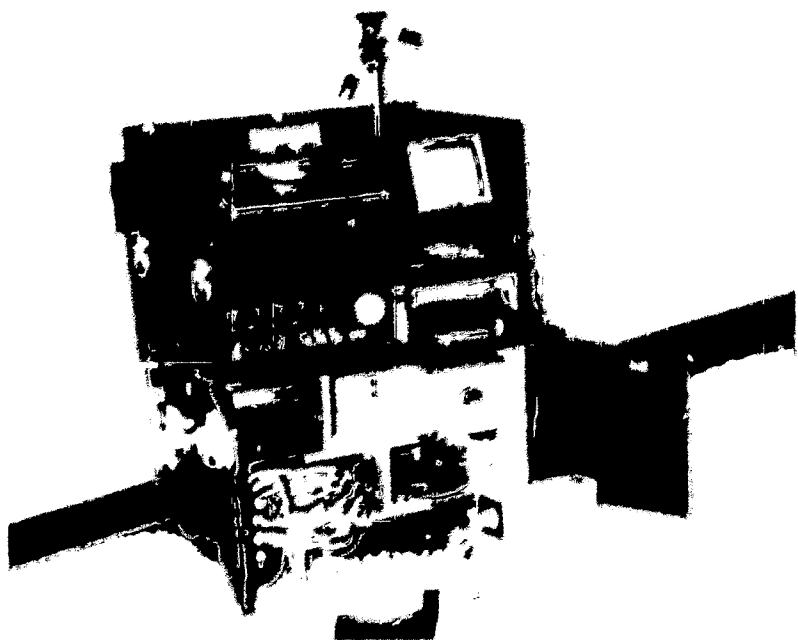

COMPLETE "MOBILE VIDEO CENTER"

This housing unit was designed and constructed specifically for the project at the University of Illinois. The camera support behind the monitor is a modified tripod, mounted permanently, allowing full elevation, panning and tilting of a normal tripod.

MOBILE VIDEO CENTER PARTIALLY SET UP

The Mobile Unit consists of a half-inch recorder, two cameras, two floor stand microphones, one lavalier microphone, a 9" television monitor, an amplifier-mixer and two special lenses which alternated between the two sets of equipment.

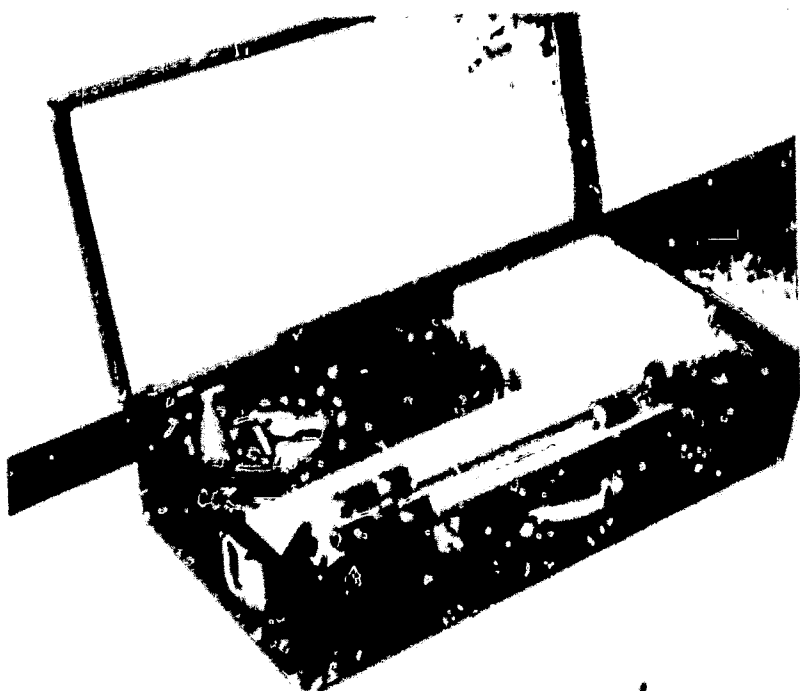
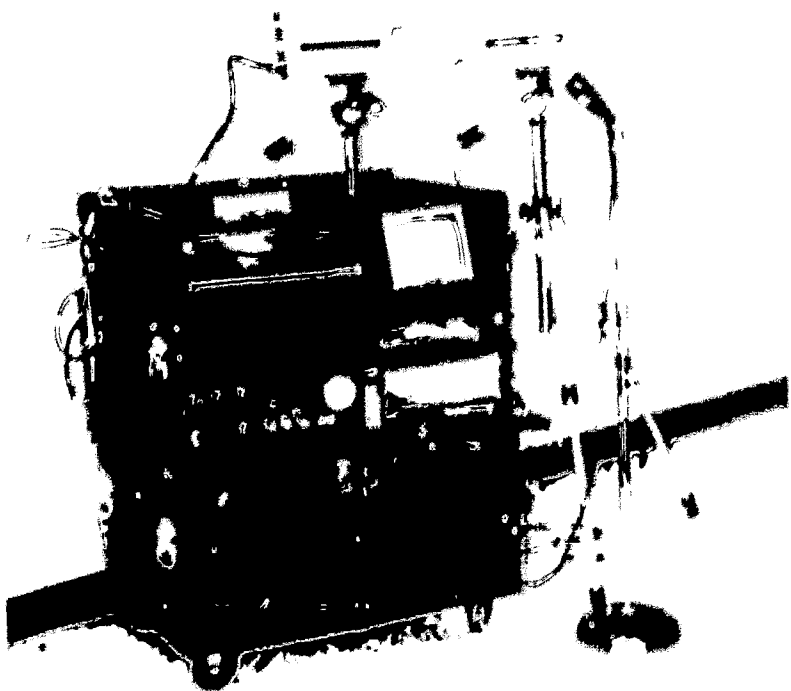

PORTABLE HOUSING UNIT TO ACCOMPANY RECORDER

This unit ("Portable Video Center") was designed to house all of the equipment included in the Mobile Video Center with the exception of the amplifier-mixer and one floor stand microphone. Without the mixer, a "Y-tap" was provided to accept both microphones.

APPENDIX B2
Transporting Equipment

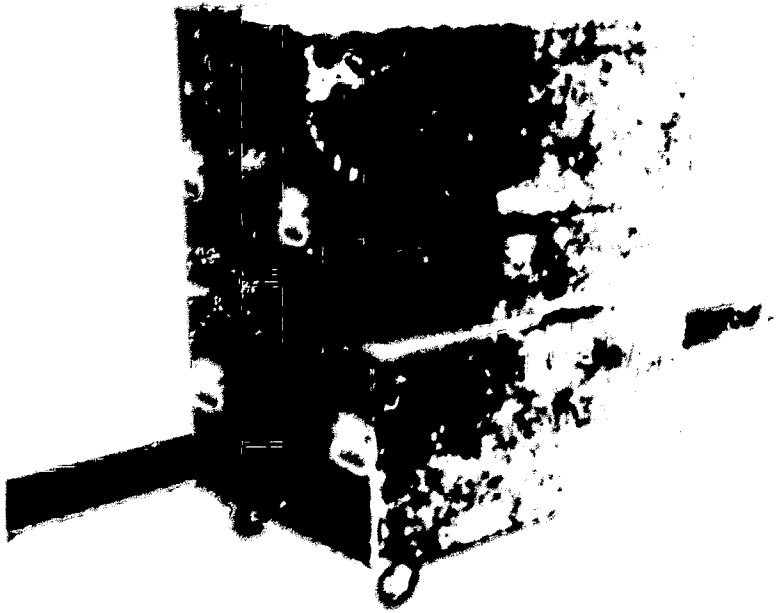

SEPARATING THE MOBILE VIDEO CENTER
FOR TRANSPORTING

Basic in the design of this unit was the need for placing it in a station wagon. Ball-type rollers were mounted under the top half to serve two purposes: (1) to facilitate loading and unloading, and (2) to serve as locating pins when the two units are assembled as one.

LOADING THE MOBILE VIDEO CENTER

After the unit has been moved to the curb on its casters, the top half is rolled into the station wagon, followed by the bottom half. To prevent rolling in transit, the two halves are fastened together with trunk clasps and the stationary casters of the bottom half are locked with two steel pins.

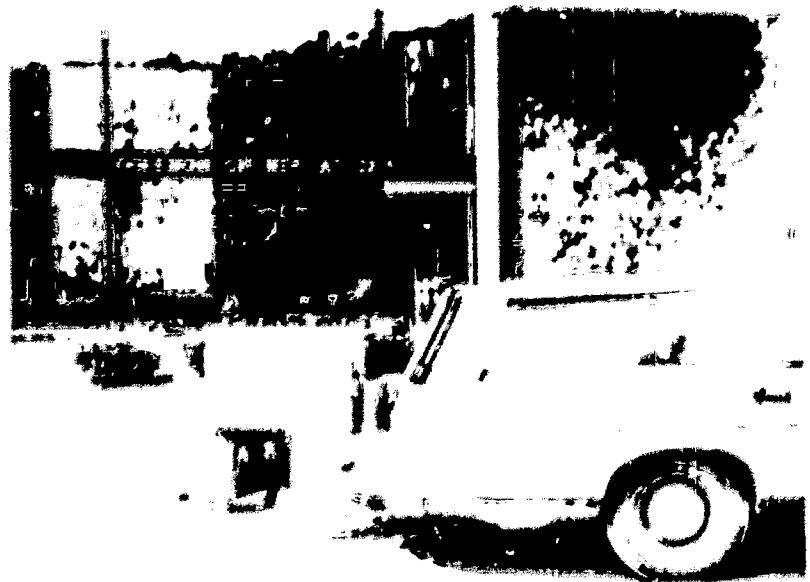

COMPLETE "PORTABLE VIDEO CENTER"

In designing the Portable Video Center housing unit to fit in a standard automobile, size and weight were given primary consideration. A castered platform provides easier movement. The recorder is carried like a suitcase.



APPENDIX B3

Special Effects Equipment

Special Effects Equipment consists of a special effects generator, a sync generator, and a special lens. Splitting the screen horizontally, vertically or by quadrants, this equipment provides simultaneous viewing of teacher and students from two cameras. Other than the two lenses, the set shown on this page costs approximately \$900. Installed in a video recording system, the price would be approximately \$1,200. The costs of the zoom and the wide-angle lenses are \$350 and \$75 respectively.

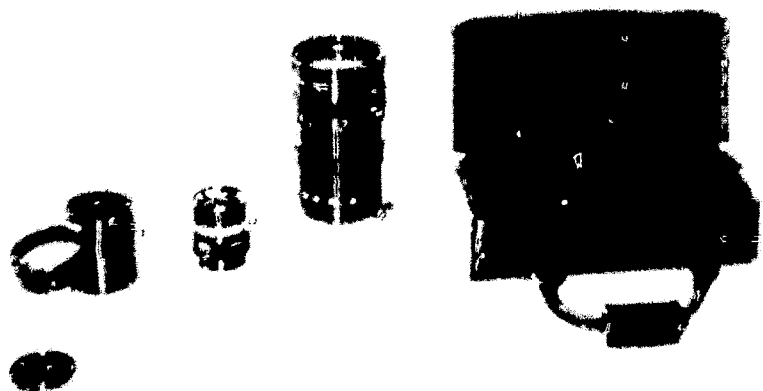
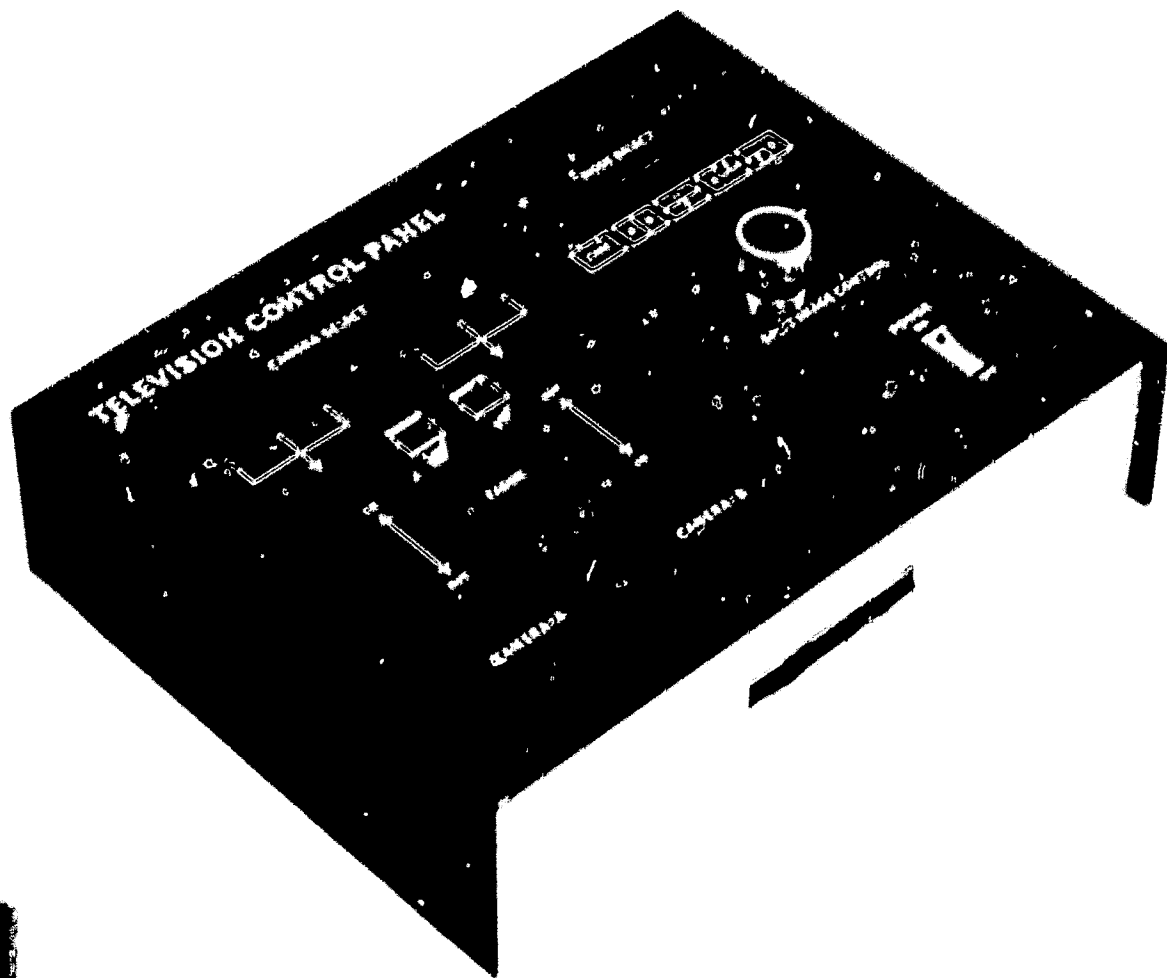
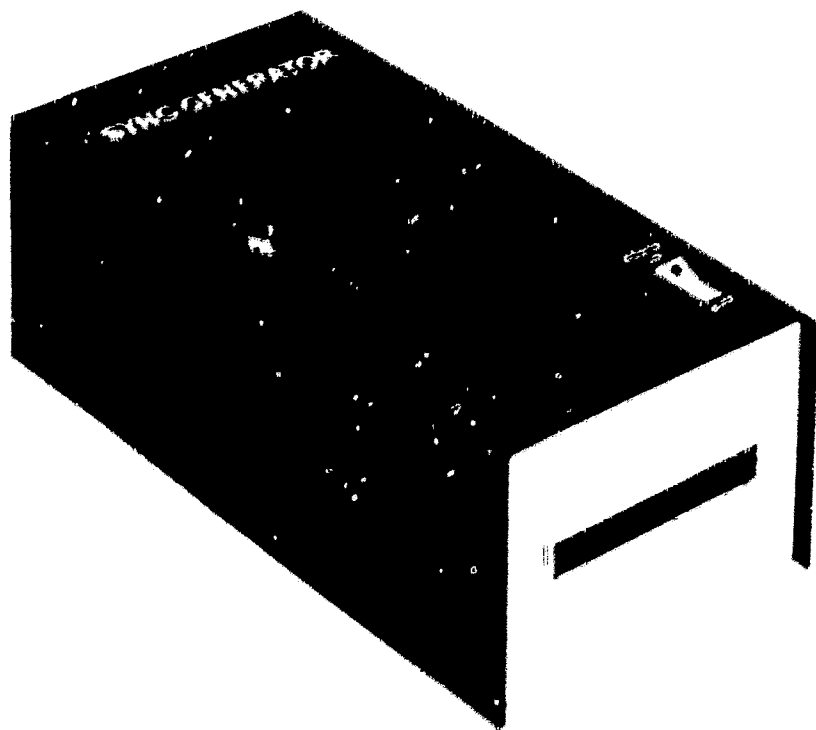

APPENDIX C1

INSTRUCTIONS FOR SETTING UP AND OPERATING

MOBILE VIDEO CENTER

INVENTORY CHECK LIST

1. Two cameras
2. Three microphones
3. One mounted T.V. monitor
4. One video recorder
5. One mounted amplifier
6. One mounted speaker
7. One mounted tripod
8. One portable tripod
9. Two mike stands with base
10. Two sets of video leads
11. One extension cord
12. One 110 volt power cord
13. One accessory kit
14. One take-up reel

PRECAUTIONS:

1. Always remove reels before fastening recorder cover for transporting the equipment.
2. Always have MOTOR SWITCH in "OFF" position when threading the tape.
3. Always avoid aiming camera directly into the sun or at high intensity light such as welding.
4. Always run motor in "STANDBY" position for ten minutes when equipment is brought in from the cold. This eliminates condensation.
5. Always have lens cap on lens when equipment is not in use. Cover lens before turning camera off.
6. Always keep tape as close to room temperature as possible.

1. Supply Reel Spindle
2. Power Button
3. Audio Level Control
4. Video Level Control
5. Motor Standby/
Motor Off Switch
6. Threading Diagram
7. Record Button

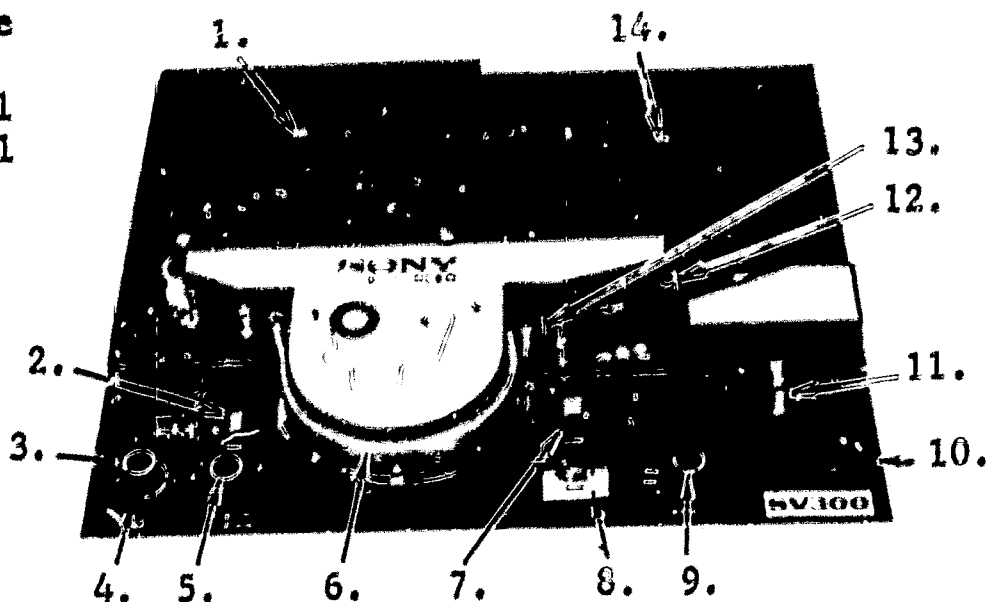

8. Level Meter
9. Meter Select Switch
10. Fast Forward Lever
11. Play-Stop-Rewind Lever
12. Tape Roller
13. Automatic Shutoff
14. Takeup Reel Spindle

WHEN YOU RECEIVE THE EQUIPMENT, the RECORD BUTTON should be 1/2" high, and the PLAY-STOP-REWIND LEVER should be in the "STOP" position. These are all on the top of the recorder. Also, the switch on the brown power supply box behind the recorder should be in the "OFF" position. The RECORD PLAYBACK switch behind the recorder should be in "RECORD".

SETTING UP AND CHECKING THE EQUIPMENT

1. Plug in black AC cord to 110 source and connect to outlet box in left end of unit.
2. Assembling camera on tripod.
 - a. Lengthen each tripod leg one section.
 - b. Extend tripod legs to maximum outward direction.
 - c. Unscrew small handle from the end of large handle and screw into tripod head.
NOTE: These handles lock the position of the head when they are turned clockwise.
 - d. Raise camera base on tripod to chest height and lock at that level.
 - e. Level camera base on tripod to horizontal position.
 - f. Tighten all knobs of tripod snugly.
 - g. Turn screw on tripod until threads protrude 1/4" above cork pad.

- h. Holding Camera #2 securely with lens opposite long handle of tripod, place threaded hold (bottom of camera) in position over the screw and tighten the screw as far as it will go with finger pressure.
 - i. Turn large black collar around screw in same direction as screw was turned and make it snug thus adding greater security.
 - j. Test the assembly to be sure camera is well fastened.
 - k. Place Camera #1 on mounted tripod head in same manner as Camera #2 was mounted.
3. Plug camera 110 leads to brown power supply box and connect at camera.
 4. Connect pink leads to cameras and outlet box.
 5. Connect green video lead to Camera #1 and outlet box video #1. Connect yellow video lead to Camera #2 and outlet box Video #2.
 6. Assemble mike stands and screw mike into stand.
 7. Plug mikes into outlet box. (Audio 1, 2, 3).

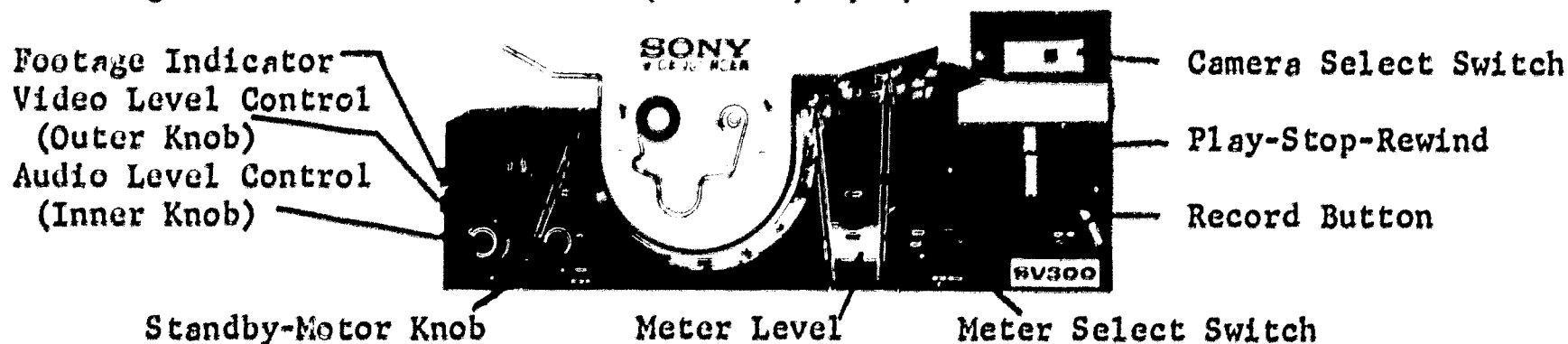

8. Put RECORD-PLAYBACK SWITCH in "RECORD". (Located on top of box behind recorder.)
9. Thread tape from supply reel, placed on left spindle, to take-up reel on right spindle, following threading diagram on recorder.
NOTE: PLAY-STOP-REWIND LEVER must be in "STOP" position.
10. Switch on power at brown power supply box behind recorder.
11. Depress red RECORD BUTTON. (It will stay down)
12. Unscrew lens cap and store carefully. (SHOULD NOW HAVE LIVE PICTURE)
13. To check video:
Move METER SELECT SWITCH to "VIDEO",
CAMERA SELECT SWITCH to "CAMERA #1".
Check front collar of lens to be sure the red arrow points to "2.8" setting.
Adjust 2nd collar of lens to get maximum sharpness.
Repeat for 2nd camera with CAMERA SELECT SWITCH in "CAMERA #2"
14. To adjust video:
Move METER SELECT SWITCH TO "VIDEO" position.
Adjust VIDEO LEVEL CONTROL (outer knob, lower left) to have meter reading in green (There is no need to adjust for both cameras.)
15. To adjust audio:
Move METER LEVEL CONTROL (inner knob, lower left) to have meter reading that seldom pegs the meter.
16. Turn on by pulling STANDBY-MOTOR OFF KNOB up.

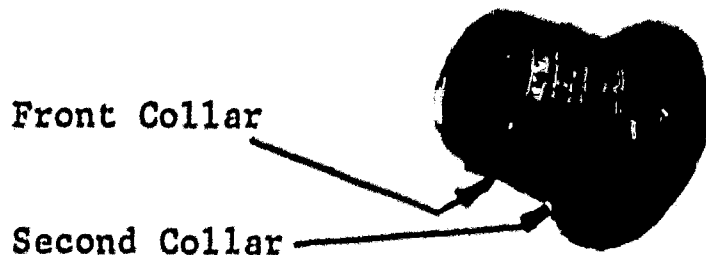

TO RECORD

1. Start footage indicator at 000 by pushing down on small black knob.
2. Hold down on red RECORD BUTTON; push PLAY-STOP-REWIND LEVER to "PLAY" (SHOULD STILL HAVE LIVE PICTURE, REELS REVOLVING).
3. Knob on side of speaker box should be turned counterclockwise to "OFF" position.
NOTE: During "RECORD," check and, if necessary, adjust AUDIO KNOB (lower left) for reading in the green area.
4. To change cameras. switch CAMERA SELECTOR to "1" or "2."

TO PLAYBACK

1. Move PLAY-STOP-REWIND LEVER to "STOP" position. Move right to "REWIND" position and stop at 000 reading on footage indicator.
2. Move RECORD-PLAYBACK KNOB to "PLAYBACK". (Located on top of box behind recorder.)
3. Move PLAY-STOP-REWIND LEVER to "PLAY".
4. Adjust VOLUME CONTROL KNOB on side of speaker.

DISMANTLING THE EQUIPMENT

1. Replace lens cover on both cameras.
2. Move PLAY-REWIND LEVER to "REWIND".
NOTE: Machine will turn off automatically when tape runs out.
3. Remove reels and store in appropriate containers.
4. Reset switches to following positions: The RECORD BUTTON should be 1/2" high; the PLAY-REWIND LEVER should be in "STOP" position. The switch on the brown outlet box should be in "OFF" position. The RECORD-PLAYBACK switch should be in the "RECORD" position. Push down MOTOR OFF SWITCH.
5. Disconnect all wires and store in cart.
6. Remove cameras from tripods and store in containers.
7. Dismantle tripod and store in cart.
NOTE: Small handle screws out of tripod head into the end of large handle. Screw must be level with cork surface.
8. Unscrew mikes and store in cart.
NOTE: Mike stand must be taken apart to be stored.

CLEANING ROTARY HEADS

BEFORE ATTEMPTING TO CLEAN ROTARY HEADS, DISCONNECT VIDEORECORDER FROM EXTERNAL POWER SOURCE.

1. Move the rotary head to the groove for cleaning on the left side (see photo) by gently pushing the head around with the cleaning tip (supplied in the accessory kit).
2. Gently hold the edge of the rotary head with your finger tip to keep head from moving during cleaning.
3. Press the cleaning trip lightly against the head, and clean by moving the cleaning tip from right to left, NEVER MOVE THE CLEANING TIP VERTICALLY.
4. Move the other head on the opposite side around gently with the cleaning tip, and clean it in the same manner.

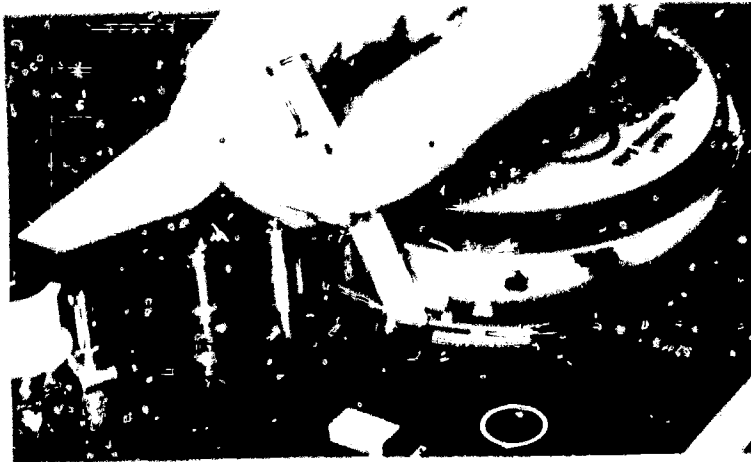

3/28/68

APPENDIX C2

INSTRUCTIONS FOR SETTING UP AND OPERATING

PORTABLE VIDEO CENTER

INVENTORY CHECK LIST

1. Two cameras
2. Two microphones
3. One T.V. monitor
4. One mike stand with base
5. One video recorder
6. Two sets of video leads
7. One 110 volt power cord
8. One extension cord

PRECAUTIONS:

1. Always remove reels before fastening recorder cover for transporting the equipment.
2. Always have MOTOR SWITCH in "OFF" position when threading the tape.
3. Always avoid aiming camera directly into the sun or at high intensity light such as welding.
4. Always run motor in "STANDBY" position for ten minutes when equipment is brought in from the cold. This eliminates condensation.
5. Always have lens cap on lens when equipment is not in use. Cover lens before turning camera off.
6. Always keep tape as close to room temperature as possible.

1. Supply Reel Spindle
2. Power Button
3. Audio Level Control
4. Video Level Control
5. Motor Standby/
Motor Off Switch
6. Threading Diagram
7. Record Button
8. Level Meter
9. Meter Select
Switch

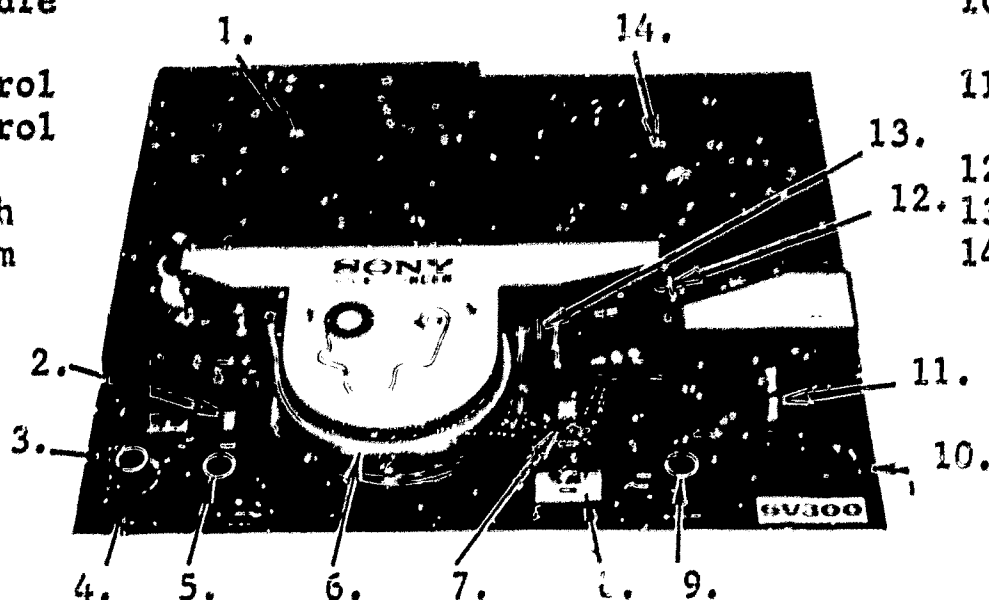

10. Fast Forward
Lever
11. Play-Stop-Rewind
Lever
12. Tape Roller
13. Automatic Shutoff
14. Takeup Reel
Spindle

WHEN YOU RECEIVE THE EQUIPMENT, the RECORD BUTTON should be 1/2" high, and the PLAY-STOP-REWIND LEVER should be in "STOP" position. These are all on top of the recorder. The OFF-ON SWITCH on the T.V. monitor should be in "OFF" position.

SETTING UP AND CHECKING THE EQUIPMENT

1. Assembling cameras on tripod.
 - a. Lengthen each tripod leg one section.
 - b. Extend tripod legs to maximum outward direction.
 - c. Raise camera base on tripod to chest height and lock at that level.
 - d. Level camera base on tripod to horizontal position.
 - e. Tighten all knobs of tripod snugly. NOTE: Handles lock the position of the head when they are turned clockwise.
 - f. Turn screw on tripod until threads protrude 1/4" above cork pad.
 - g. Holding Camera #2 securely with lens opposite long handle of tripod, place threaded hold (bottom of camera) in position over the screw and tighten the screw as far as it will go with finger pressure.
 - h. Turn large black collar around screw in same direction as screw was turned and make it snug thus adding greater security.
 - i. Test the assembly to be sure camera is well fastened.
 - j. Place Camera #1 on other tripod head in same manner as Camera #2 was mounted.

2. Place recorder on convenient horizontal surface (minimum size: 16" X 26") and remove top;
 3. Place T.V. monitor at right of recorder facing operator (remove shield).
 4. Assemble mike stand and screw mike onto stand. (Place near recorder for testing purposes.)
 5. Connect all leads according to color coding to back of recorder, except for the plugs labeled "TO CAMERA".
 6. Connect green video lead to Camera #1, and yellow video lead to Camera #2.
 7. Connect pink leads to cameras.
 8. Plug camera 110 leads to power supply (back of recorder) and connect at camera.
 9. Connect 110 volt power cord to the recorder. NOTE: Cord has twist lock plug. Insert and turn right to assemble.
 10. Thread tape from supply reel, placed on left spindle, to take-up reel on right spindle, following threading diagram on recorder.
- NOTE: PLAY STOP REWIND LEVER must be in "STOP" position.

Sequence in turning equipment on. To prevent damage to the equipment, it is essential that the switches with red labels 1 through 4 be turned on in that order.

1. Turn on #1 switch on TV monitor.
2. Turn on #2 switch on Camera.
3. Turn on #3 switch on recorder.

NOTE: The #3 switch is turned on and off by simply depressing the gray button. "ON" position is depressed. "OFF" position is up.

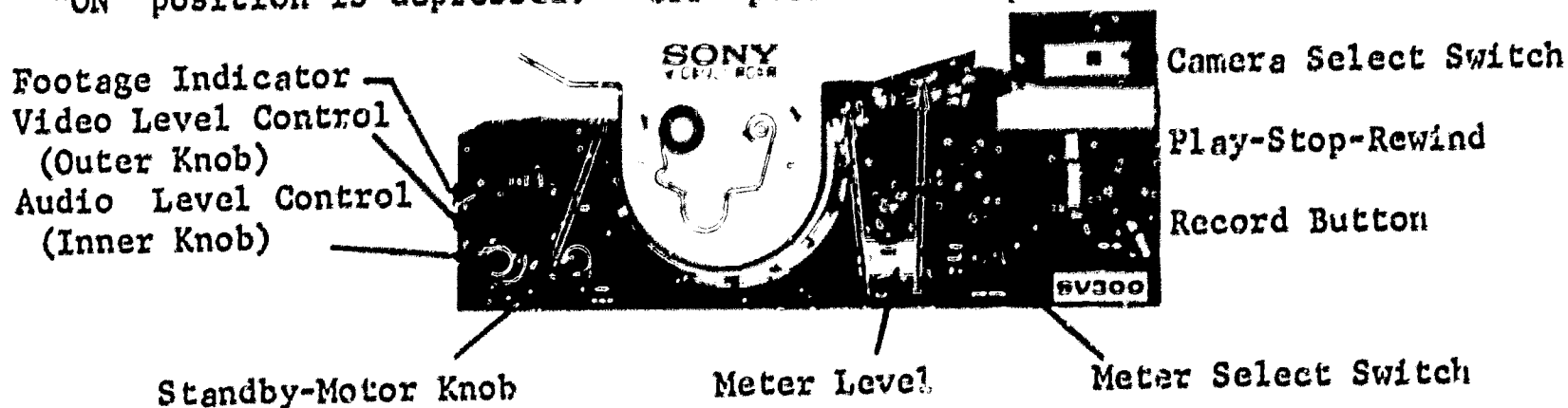

4. Depress red RECORD BUTTON. (It will stay down.)
5. Unscrew lens cap and store carefully. (SHOULD NOW HAVE LIVE PICTURE)
6. To check video:

Move METER SELECT SWITCH to "VIDEO".
 CAMERA SELECT SWITCH to "CAMERA #1".
 Check front collar of lens to be sure the red arrow points to "2.8" setting.
 Adjust 2nd collar of lens to get maximum sharpness.

Front Collar

Second Collar

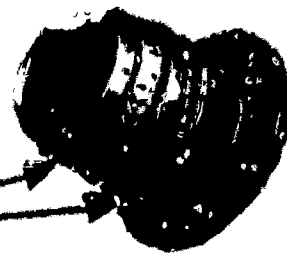

- Repeat for 2nd camera with CAMERA SELECT SWITCH in "CAMERA #2".
7. To adjust video:
 Move METER SELECT SWITCH to "VIDEO" position.
 Adjust VIDEO LEVEL CONTROL (Outer knob, lower left) to have meter reading in green. (There is no need to adjust for both cameras.)
 8. Turn on by pulling STANDBY-MOTOR KNOB #4 up.

TO RECORD

1. Start footage indicator at 000 by pushing down on small black knob.
2. Hold down on red RECORD BUTTON: push PLAY-STOP-REWIND LEVER to "PLAY."
 (SHOULD STILL HAVE LIVE PICTURE, REELS REVOLVING).
3. OFF-ON SWITCH on monitor should be turned counterclockwise to low position but not to "OFF" position.
4. Turn "AUDIO LEVEL" knob to maximum setting, extreme clockwise. (Inner knob, lower left).
5. To check audio, move METER SELECT SWITCH to "AUDIO" position; should have meter reading that seldom pegs the meter.

TO PLAYBACK

1. Move PLAY-STOP-REWIND LEVER to "STOP" position. Move right to "REWIND" position and stop at "000" reading on footage indicator.
2. Move PLAY STOP REWIND LEVER to "PLAY".
3. Adjust volume with OFF-ON knob on front of monitor. (Turn clockwise)

DISMANTLING THE EQUIPMENT

1. Replace lens cover on both cameras.
2. Move PLAY-STOP-REWIND LEVER to "REWIND".
NOTE: Machine will turn off automatically when tape runs out.
3. Remove reels and store in appropriate containers.
4. Turn off equipment in following order: #4, #3, #2, #1
NOTE: Move PLAY STOP REWIND LEVER to "STOP".
5. Disconnect all wires and store in case.
NOTE: 110 power cord has a twist lock plug. Turn left and pull to disengage.
NOTE: Both the light blue and the copper color coded plugs have releases which must be pushed to withdraw plug.
6. Remove cameras from tripods and store in case.
7. Dismantle tripod and store in case.
8. Unscrew mike and store in case. NOTE: Mike stand must be taken apart to be stored.
9. The cords that are bound together are left connected to monitor.

CLEANING ROTARY HEADS

BEFORE ATTEMPTING TO CLEAN ROTARY HEADS, DISCONNECT VIDEOCODER FROM EXTERNAL POWER SOURCE.

1. Move the rotary head to the groove for cleaning on the left side (see photo) by gently pushing the head around the cleaning tip (supplied in the accessory kit).
2. Gently hold the edge of the rotary head with your finger tip to keep head from moving during cleaning.
3. Press the cleaning tip lightly against the head, and clean by moving the cleaning tip from right to left. NEVER MOVE THE CLEANING TIP VERTICALLY.
4. Move the other head on the opposite side around gently with the cleaning tip, and clean it in the same manner.

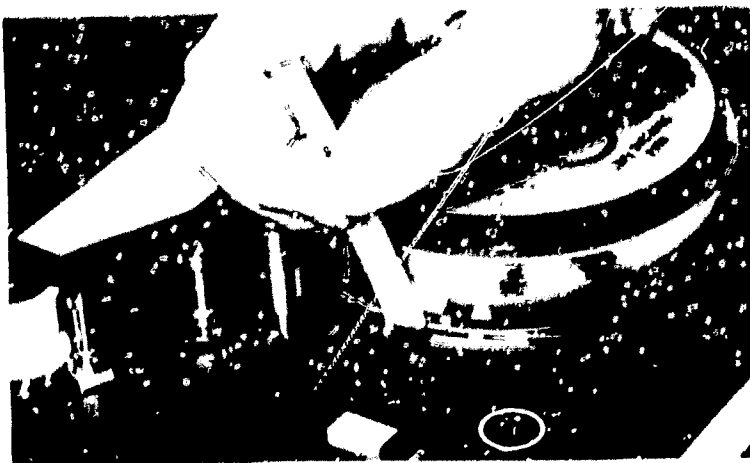

3/28/68

VOTEC MICRO-TEACHING PROJECT
INSTRUCTIONS FOR USING ZOOM LENS

TO MOUNT ZOOM LENS

1. Remove standard lens from camera by revolving it counterclockwise as viewed from front of camera; store in plastic container.
2. Remove zoom lens from black leather container.
3. Unscrew cap from small end of zoom lens and store in black leather container.
4. Remove small ZOOM CONTROL HANDLE from black leather container and screw into small hole in middle collar of zoom lens.
5. Screw small end of zoom lens into camera, revolving it clockwise.
6. Turn camera on and remove lens cover.

TO ADJUST LENS

1. Check back collar to be sure the arrow points to "2.8" setting.
 2. Adjust zoom to "25MM" (wide picture) position by moving ZOOM CONTROL HANDLE counterclockwise as viewed from the operator's position.
 3. Adjust NEAR-FAR KNOB on back of camera for maximum sharpness.
 4. Adjust zoom to 100MM (close-up) position by moving zoom control clockwise.
 5. Focus lens by revolving front collar of zoom for maximum sharpness.
- NOTE: If the focusing changes in the process of zooming, it is because the NEAR-FAR KNOB on back of camera is not in the correct position. In this case, it is necessary to go through steps 2, 3, 4, and 5 again.

REMOVING AND STORING ZOOM LENS

1. Replace lens cover.
2. Turn camera off.
3. Remove ZOOM CONTROL HANDLE from lens and store in black leather container.
4. Remove zoom lens from camera by revolving counterclockwise.
5. Screw cap onto small end of zoom lens and store in black leather container.
6. Remove standard lens from plastic container and screw into camera revolving it clockwise.

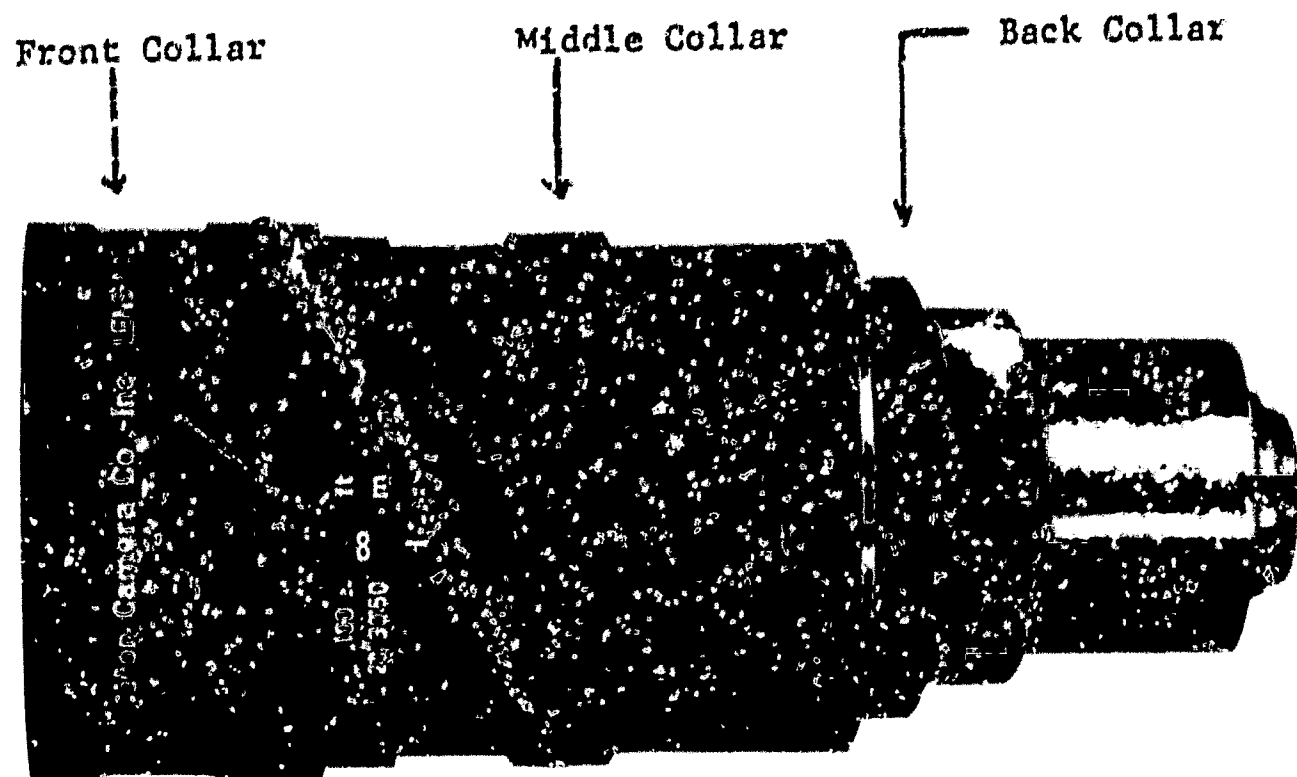

3/28/68

APPENDIX D

Developing Model Tapes on One-Half-Inch Sony Equipment

Dubbing (without captioning or voice override) Procedure

(Note: Two recorders and a TV monitor are required.)

Connections

1. On Recorder #1 place the tape containing the portion to be transferred.
2. On Recorder #2 place the fresh tape which will receive the dubbed portion.
3. Connect the jack "Video Out" on Recorder #1 to "Video In 1" on Recorder #2.
4. Connect "Audio (or "Line") Out" on Recorder #1 with "Audio (or "Line") In" on Recorder #2.
5. For viewing of model tape being dubbed, connect "Video Out" on Recorder #2 to "Video In" on TV monitor and "Audio Out" to "Audio In" on the monitor.

Procedures

1. Turn Recorder #1 on "Play" and Recorder #2 on "Record."
2. Check both the audio and video levels on Recorder #2 by playing part of the selection to be dubbed and adjust accordingly.
3. On Recorder #1, note the footage for the section of tape to be transferred, for example, from 037 to 059.
4. Stop both recorders and rewind tape. Bring Recorder #2 back to 000. Recorder #1 should be brought back to the original 037 plus five feet which would then be 032. The additional five feet will allow the picture to stabilize before being transferred to the new tape, thus minimizing the rolling of the picture on the model tape.
5. Turn Recorder #1 to "Play."
6. When 037 footage appears, turn Recorder #2 on "Record."
7. When 059 footage appears on Recorder #1, stop Recorder #2 and Recorder #1 in that order.
8. Repeat this operation for each portion being transferred.
9. The quality of the recording depends on the accuracy of the operator in anticipating the time for switching of the machines. This calls for the trial and error method and each dubbed portion of the recording should be viewed when completed.

Dubbing (with captioning) Procedure

(Note: Two recorders, a TV monitor, and a set of letters for captioning are required.)

Connections

1. On Recorder #1 place the tape containing the portion to be transferred.
2. On Recorder #2 place the fresh tape which will receive the dubbed portions.
3. Connect the jack "Video Out" on Recorder #1 to "Video In 1" on Recorder #2.
4. Connect "Audio (or "Line") Out" on Recorder #1 to "Audio (or "Line") In" on Recorder #2.
5. For viewing of model tape being dubbed, connect "Video Out" on Recorder #2 to "Video In" on TV monitor and "Audio Out" to "Audio In" on the monitor.
6. Mount camera on tripod and connect the jack "Video Out" on camera to "Video In 2" on Recorder #2.

Procedures

1. Move "Camera Select" switch to "Camera #2."
2. Depress "Record" button on Recorder #2 and position camera on captioning while viewing monitor.
3. Move "Camera Select" switch to "Camera #1."
4. Turn Recorder #1 on "Play" and Recorder #2 on "Record."
5. Check both the audio and video levels on Recorder #2 by playing part of the selection to be dubbed and adjust accordingly.
6. Move "Camera Select" switch to "Camera #2" and check "Video Level" adjustments by changing the "Beam" adjustment on the camera.
7. Stop Recorder #1 and bring back to 000 reading and Recorder #2 to 031 reading.
8. Turn on Recorder #2 and start to record captioning.
9. Turn Recorder #1 to "Play."
10. When 037 footage appears on Recorder #1, move "Camera Select" switch to "Camera #1."

11. When 059 footage appears on Recorder #1, stop Recorder #2 and Recorder #1 in that order.
12. Repeat the operation for each portion being transferred checking the progress of the model tape after each addition.

Dubbing (with captioning and voice override) Procedure

(Note: Two recorders, a TV monitor, a set of letters, a microphone, an audio "Y-tap," and an audio cable with "Off-On" switch are required.)

Connections

1. On Recorder #1 place the tape containing the portion to be transferred.
2. On Recorder #2 place the fresh tape which will receive the dubbed portions.
3. Connect "Y-tap" to "Audio (or "Line") In" on Recorder #2.
4. Connect microphone to one side of "Y-tap."
5. Connect audio cable with "Off-On" switch (in "Off" position) from other side of "Y-tap" to "Audio Out" on Recorder #1.
6. Connect the jack "Video Out" on Recorder #1 to "Video In 1" on Recorder #2.
7. For viewing of model tape being dubbed, connect "Video Out" on Recorder #2 to "Video In" on TV monitor and "Audio Out" to "Audio In" on the monitor.
8. Mount camera on tripod and connect the jack "Video Out" on camera to "Video In 2" on Recorder #2.

Procedures

1. Move "Camera Select" switch to "Camera #2."
2. Depress "Record" button on Recorder #2 and position camera or captioning while viewing monitor.
3. Move "Camera Select" switch to "Camera #1."
4. Turn Recorder #1 on "Play" and Recorder #2 on "Record."
5. Check both the audio and video levels on Recorder #2 by playing part of the selection to be dubbed and adjust accordingly.

6. To check the number of feet needed for voice override:
 - a. Begin recording on Recorder #2 and note footage reading.
 - b. Speak into microphone using prepared script.
 - c. When finished with script, stop Recorder #2 and note footage reading.
 7. Rewind Recorder #2 to 000 reading and Recorder #1 should be brought back to original 037 plus the number of feet needed for the prepared script.
 8. Turn Recorder #2 on "Record" and Recorder #1 on "Play."
 9. Speak into microphone using prepared script.
 10. When 037 footage appears move "Camera Select" switch on Recorder #2 to "Camera #1" position and audio "Off-On" switch in cable to "On."
 11. When 059 footage appears on Recorder #1, stop Recorder #2 and Recorder #1 in that order.
 12. Repeat this operation for each portion being transferred, checking the progress of the model tape after each addition.
- (Note: Patience is required in developing model tapes. In some cases several tries are needed to obtain the quality of tape desired.)

APPENDIX E

Participants

Robert Fink, Danville Junior College, Danville, Illinois

Tom Hainline, Danville Junior College, Danville, Illinois

Marilyn Weinard, Danville Junior College, Danville, Illinois

Felix Wheeler, Danville Junior College, Danville, Illinois

Alvin Wilcox, Danville Junior College, Danville, Illinois

Dennis Harding, Decatur Area Vocational Center, Decatur, Illinois

Jack Kitchen, Decatur Area Vocational Center, Decatur, Illinois



	3%		15%		15%		15%		10%	
	WEAK	BELOW AVERAGE	AVERAGE	STRONG	SUPERIOR	OUTSTANDING	TRULY EXCEPTIONAL			
AIMS										
A. Were the learning aims of this micro-lesson understood?	1 no understanding	2 doubtful understanding	3 some understanding	4 generally understood	5 good understanding	6 clearly understood	7 exceptional understanding			
B. Were the learning aims of this micro-lesson developed?	1 no development	2 doubtful development	3 some development	4 generally developed	5 good development	6 clearly developed	7 exceptional development			
CONTENT										
C. Was the content of this micro-lesson meaningful?	1 no meaning	2 doubtful of meaning	3 some meaning	4 generally meaningful	5 mostly meaningful	6 clearly meaningful	7 superior meaningfulness			
D. Was the content of this micro-lesson well organized?	1 not organized	2 unclear organization	3 some organization	4 generally organized	5 good organization	6 clearly organized	7 exceptional organization			
METHOD										
E. Was the method employed appropriate to the aims of the micro-lesson?	1 not appropriate	2 doubtful of appropriateness	3 not entirely appropriate	4 generally appropriate	5 appropriate	6 clearly appropriate	7 exceptionally appropriate			
F. Was the method employed stimulating to the learner?	1 not stimulating	2 little stimulation	3 some stimulation	4 generally stimulating	5 stimulating	6 very stimulating	7 exceptionally stimulating			
G. Was the method employed successful in terms of the lesson's learning aims?	1 not successful	2 little success	3 some success	4 generally successful	5 successful	6 clearly successful	7 exceptionally successful			
EVALUATION										
H. Did the teacher evaluate his success by keeping in contact with the learners?	1 no contact	2 little contact	3 some contact	4 generally in contact	5 in contact	6 very much in contact	7 exceptional contact			
I. Did the teacher's method of lesson evaluation encourage learner participation?	1 no encouragement	2 little encouragement	3 some encouragement	4 generally encouraging	5 encouraging	6 clearly encouraging	7 exceptional encouragement			
ACCOMPLISHMENT										
J. Does the learner have a feeling of accomplishment concerning this micro-lesson?	1 nothing accomplished	2 little accomplished	3 some accomplishment	4 general feeling of accomplishment	5 lesson accomplished	6 clearly accomplished	7 exceptional accomplishment			