

ED 027 750

56

EM 007 151

By- Allen, William H.; Weintraub, Royd
The Motion Variables in Film Presentations. Final Report.
University of Southern California, Los Angeles.
Spons Agency- Office of Education (DHEW), Washington, D.C. Bureau of Research.
Bureau No-BR-5-1123
Pub Date Dec 68
Grant-OEG-4-6-051123-1300
Note- 128p.
EDRS Price MF-\$0.75 HC-\$6.50

Descriptors-*Cognitive Processes, Concept Formation, Films, *Motion, Pictorial Stimuli, Psychomotor Skills, Sciences, Serial Ordering, Social Studies, Statistical Analysis, *Visual Learning

The motion variable in the learning process was investigated in three parallel experiments (science, motor skills, social studies), each designed to meet instructional objectives of fact learning, serial ordering, and concept learning. Stimulus sequences were shown as motion pictures, sequenced still pictures, or single still pictures to 582 randomly assigned fifth and sixth grade students who were given objective tests after exposure to each of the treatment modes. The motion picture mode of visual presentation was superior to sequenced and still picture modes for seven of ten stimulus sequences, this superiority prevailing regardless of grade level, sex, mental ability, subject matter content, or instructional objective. Results imply that under most conditions the motion picture is the most effective for presenting information to be learned cognitively. In addition to statistical data, appendices supply stimulus materials, performance tests, and learner characteristic analysis. (TI)

ED 027750

FINAL REPORT
Project No. 5-1123
Grant No. OEG-4-6-051123-1300

THE MOTION VARIABLES IN FILM PRESENTATIONS

William H. Allen
Royd Weintraub

University of Southern California
University Park
Los Angeles, California 90007

December 1968

U.S. DEPARTMENT OF
HEALTH, EDUCATION, AND WELFARE

Office of Education
Bureau of Research

U.S. DEPARTMENT OF HEALTH, EDUCATION & WELFARE
OFFICE OF EDUCATION

THIS DOCUMENT HAS BEEN REPRODUCED EXACTLY AS RECEIVED FROM THE
PERSON OR ORGANIZATION ORIGINATING IT. POINTS OF VIEW OR OPINIONS
STATED DO NOT NECESSARILY REPRESENT OFFICIAL OFFICE OF EDUCATION
POSITION OR POLICY.

Final Report

Project No. 5-1123
Grant No. OEG-4-6-051123-1300

THE MOTION VARIABLES IN FILM PRESENTATIONS

William H. Allen

and

Royd Weintraub

University of Southern California
Los Angeles, California 90007

December 1968

The research reported herein was performed pursuant to a grant with the Office of Education, U.S. Department of Health, Education, and Welfare. Contractors undertaking such projects under Government sponsorship are encouraged to express freely their professional judgment in the conduct of the project. Points of view or opinions stated do not, therefore, necessarily represent official Office of Education position or policy.

U.S. DEPARTMENT OF
HEALTH, EDUCATION, AND WELFARE

Office of Education
Bureau of Research

ED 027750

EM007151

ACKNOWLEDGMENTS

Special appreciation is extended to Dr. W. Norman Wampler, Superintendent of Schools, and Dr. Margaret L. Orear, Deputy Superintendent of Schools, who generously made available the facilities of the Bellflower Unified School District. In particular we wish to thank the following elementary school principals and their staffs, who cooperated in the actual conduct of the experiment: Miss Eunice Gaines, Ernie Pyle School; Mrs. Elizabeth Cooke, Woodrow Wilson School; Mr. Jack Reynolds, Esther Lindstrom School; Mr. Leonard Bellamy, May Thompson School; Mr. Jack Witt, Ramona School; Mr. Andrew Smith, Las Flores School; and Mr. Robert Candelaria, Thomas Jefferson School.

Deserving special mention are individuals who participated in different parts of the study: Dr. Stuart M. Cooney, who assisted in the early design phases of experiment; Donald Estavan, who developed the performance tests; Mr. Leonard Lodico and Miss Helen Huang, who managed the data analysis; Mr. William Daehling, Mr. Thomas Nielsen, Mr. J. J. Russell, Mr. Benjamin Sweet, and Mrs. Elaine Wagner, who assisted in the administration of the experimental treatments.

CONTENTS

	Page
ACKNOWLEDGMENTS	ii
SUMMARY	1
Chapter	
I. INTRODUCTION	3
The Problem	3
Review of Related Research	4
II. METHOD AND PROCEDURES	11
Experimental Design and Method	11
Experimental Population	14
Development of Experimental Stimulus Materials	15
Instrumentation	18
Measuring Instruments	18
Conduct of the Experiments	20
Preparation of Data and Statistical Analysis	20
III. RESULTS	23
Analysis of Total Performance	23
Analysis by Learner Characteristics	31
Analysis of Total Performance for Individual Test Items	34
Attitude Toward the Stimulus Presentations	57

Chapter	Page
IV. CONCLUSIONS AND DISCUSSION	63
Conclusions	63
Discussion	64
REFERENCES	69
APPENDICES:	
Appendix A: Stimulus Materials	73
Appendix B: Performance Tests	79
Appendix C: Results of Analyses for Learner Characteristics	108
Appendix D: Analysis of Performance on Individual Test Items	116

SUMMARY

This study had as its purpose the investigation of the motion variable upon the learning of cognitive information. To accomplish this, visual pictorial presentations were made under three different motion and still picture conditions.

Objectives

The study had as its overall objective the determination of the appropriateness of motion in communicating cognitive information. The specific objectives studied were:

1. To determine the comparative effectiveness of three visual presentation modes--motion pictures, sequenced still pictures simulating movement, and single still pictures showing the principal points of the action--as related to:

- a. Subject matter content areas.
- b. Instructional objectives being served.
- c. Characteristics of the learner.

2. To determine the relationships between performance on the different modes of visual presentation and attitude toward the stimulus presentation.

Procedure

Three parallel experiments were conducted, each in a different subject matter area (science, motor skills, social studies), and each designed to meet three different instructional objectives (knowledge of specific facts, serial ordering, learning concepts). Three stimulus sequences were designed for each content/objectives combination, comprising a total of 9 sequences for each experiment and 27 for the total study. Each sequence was presented as a motion picture, as sequenced still pictures, or as single still pictures, making a total of 81 experimental treatments. Subjects were 582 fifth and sixth grade students, assigned at random to the experimental treatments. Performance was tested by means of objective tests given after the exposure to each of the treatments. Qualitative reactions of the subjects were obtained to each of the treatment modes. Analysis of results was by analysis of variance, t-test comparisons, and correlation analysis.

Results and Conclusions

The results and conclusions are summarized for the major comparisons, the learner characteristics, and the qualitative reactions:

1. The motion picture mode of visual presentation was superior to the sequenced and still picture modes for seven of ten stimulus sequences, this superiority prevailing regardless of grade level, sex, mental ability, subject matter content, or instructional objective.

2. There were no practical differences in the effectiveness of the two still picture modes of visual presentation.

3. Concept learning appeared to be less subject to influence by the mode of visual presentation than either learning of specific facts or serial ordering.

4. Serial ordering of the content seemed to be most susceptible to influence by the motion picture mode.

5. The mode of visual presentation seemed to have the least influence upon performance in presenting specific facts in science and concepts in motor skill content.

6. There appeared to be no relationships between the sex or mental ability level of the subjects and their performance under different experimental conditions.

7. Subjective attitude toward the mode of visual presentation was not a factor in learning the content.

CHAPTER I

INTRODUCTION

This exploratory study was directed toward an investigation of various facets of the motion variable as it operated in the presentation of visual instructional media. The systematic investigation of specific design factors in instructional media has been largely neglected, particularly as these factors relate to the unique characteristics of the content being presented, the instructional objectives being served, and the learners being taught.

To the instructional motion picture film has been attributed certain qualities that have not been subjected to critical analysis and research. These center around the property of "motion," and overgeneralized claims for the appropriateness of the motion picture film have been made because it possesses this particular characteristic. Yet no extensive study has been made to determine under what conditions the depiction of "motion" is indicated in the design or selection of instructional materials as an enhancement to learning. The need for this action is becoming increasingly important, however, as we move toward the development of systems of instruction in which an integrated array of instructional materials are combined to produce the optimum mix of instructional media to accomplish specified instructional tasks. It was to the investigation of this problem that the study was directed.

The Problem

This study had as its purpose the exploratory investigation of "motion" as a variable in the presentation of visual instructional material to intermediate grade students. To accomplish this purpose, visual stimuli were designed to present material having different content characteristics and meeting different instructional objectives. The stimulus content was designed in three different visual presentation modes--motion picture, sequenced still pictures, and non-sequenced single still pictures--in order to study the continuum of motion from full motion to still presentation.

Specifically, three parallel experiments were conducted, each utilizing nine separate experimental stimuli from three different subject matter content areas: science, motor skills, and social studies. Each content area experiment consisted of three separate stimuli tested for the learning of three instructional objectives: learning specific

facts, learning the serial order, and learning concepts. Each experimental stimulus was presented to both fifth and sixth grade students by means of one of the three visual presentation modes: motion picture, sequenced still pictures, and single still pictures. Subjects were tested both for cognitive learning of the content presented and attitude toward each of the stimulus presentations.

The study had as its overall objective the determination of the appropriateness of motion in communicating the information in the different subject matter content areas and for the different instructional objectives. The specific objectives studied were:

1. To determine the effectiveness of using different modes of visual presentation: motion pictures, sequenced still pictures simulating movement, and single still pictures showing the principal points in the action.

2. To determine what relationships exist, if any, between the mode of visual presentation and selected learner characteristics for different subject matter content and for material used to meet different instructional objectives.

3. To determine the relationships between performance on the different modes of visual presentation and attitude toward the stimulus presentation.

Review of Related Research

The research related to the objectives of this study will be reviewed under five general categories: the motion variable, the comparative effectiveness of motion versus still visual presentation, the relationships of visual presentation form to the learning of tasks meeting different instructional objectives, the relationships of visual presentation form to the learning of different subject matter contents, and the relationships of the characteristics of the learners to learning from different kinds of visual presentation.

The Motion Variable

Although many advantages have been attributed to the motion picture film as a channel for instruction, no intensive study has been made to determine the particular conditions under which the depiction of motion enhances learning. The study of motion as a phenomenon has been the domain of the experimental psychologists concerned with visual perception (Gibson, 1950; Michotte, 1946; Vernon, 1952), and the study of motion as an art form has been the domain of the film theorists (Eisenstein, 1942, 1949; Spottiswoode, 1950; Arnheim, 1954).

The extent of audiovisual educators' interest in motion as such is typified by Dale's (1954) claim that motion pictures have value in that they can, among other things, "present certain meanings involving motion"; and Brown, Lewis and Harclerod's (1959) attribution of special educational advantage to the film because it can "compel attention through the use of motion" and provide a "continuity of action." True though these characteristics may be, they add little of value to our knowledge of the motion variable in instruction or to the use of motion visual presentation, as contrasted to the use of still presentations, in the design of instructional media.

Some attempts have been made over the years to develop a taxonomy of motion characteristics as they pertain to instructional films. H. Y. McClusky (1924) made an analytical study of the content of educational films. He analyzed 96 silent films and classified them by the proportions of their contents comprising action, still, or subtitle material. Although informative as to the large proportion of the educational films of the time containing non-motion content (45.4%), the study contributes little to the development of a film taxonomy. The first concerted attempt to analyze the elements in an educational film was made by O'Connor (1950). He singled out 13 characteristics of word-usage and statement composition in the audio narration and 8 characteristics of visual representation. The visual characteristics were: scenes reproducing a visual experience, scenes contriving a visual experience, scenes symbolizing a visual experience, scenes presenting a familiar visual experience, repeated scenes, scenes of human activity, dramatic rating, and number of scenes. It may be observed that only two of these visual characteristics--scenes of human activity and dramatic rating--subsumed some aspects of motion, and that the others could include motion or not.

Vetter (1959) recognized two principal kinds of motion capable of being accurately and realistically reconstructed by the film medium: "(1) motion-perspective which is accomplished through camera motion, ultimately observer motion, with relations to a fixed field-of-view, and (2) objective movement which entails the photographing of movement of objects within a field-of-view." He asserted that motion-perspective was valuable in demonstrating spatial relationships and that objective-movement was useful in enabling the observer to perceive realistically that which is animate within a given field. Vetter further noted that there seemed to be four primary motion-objectives for which these two kinds of motion portrayal were employed in film communication: "(1) to heighten realism, (2) to clarify spatial relationships, (3) to depict action and interaction of objects, people, and events, and (4) to alter velocity of observation in order to give meaning to that which transpires too slowly or too rapidly to be otherwise comprehensible." Using a panel of teachers making subjective judgments of the motion-relevancy of three elementary and three secondary science and social studies films, Vetter concluded that less than half of the total footage contained in instructional films depicts motion significantly contributing to desired learning and that a significant relationship exists between the relative teaching effectiveness of a given

film and the mean motion-relevancy estimated for the film when the film was compared (subjectively) with some generalized and hypothetical "still" presentation of the same content. This study presents little of value in understanding motion as a variable in learning from films. The two types of motion Vetter identifies--motion perspective and objective movement--are too broad to be useful in characterizing the motion variable.

Motion Versus Still Visual Presentation

Little analytical research has been conducted in which the effectiveness of motion picture presentation has been compared with still pictorial presentation, either static (as in the projected frame of a slide or filmstrip) or sequenced (in which successive stills simulate motion). The largest number of studies have been evaluative in the sense that they compared the overall effectiveness of motion pictures and still filmstrips or slides. These evaluative studies were reported in detail by Allen (1960) and showed, in general, that still presentations were about as effective as motion pictures in teaching factual information. Several of the more analytical studies are reviewed below.

The most directly related study was made by Roshal (1961), in which a comparison of knot-tying performance by Naval trainees was made when the instruction was presented by motion pictures and by sequences of still pictures. The evidence significantly favored the motion picture mode, suggesting the importance of motion in portraying actions possessing continuous changes in cues. In a study of moving ("animated") versus static transparencies in verbal instruction on weapons, Silverman (1958) found no significant differences between the two methods when measured by verbal tests, but a significant superiority for the motion mode when measured by performance tests.

Hovland, Lumsdaine and Sheffield (1949) compared the effectiveness of a motion picture and a filmstrip teaching map reading to Army trainees and found no overall differences in achievement. However, when they measured the effectiveness of the two presentation modes in showing the measuring of contour interval, in which the motion picture used a "moving viewpoint (from horizontal to vertical) to show how differences in elevation of terrain are projected onto a map in the form of contour lines," the film was significantly more effective than the still filmstrip (64% to 46%). The researchers hypothesized that "the large effect of the motion picture appears to be due to the fact that in a movie the object being photographed can remain still while the angle from which it is viewed is progressively altered" and that "where familiarity with three-dimensional spatial relationships is important in learning the material, movies have an inherent advantage that cannot easily be equalled by filmstrips." In reporting the results of this study in their consideration of the psycholinguistics of cinema, Pryluck and Snow (1967) speculated that an equally reasonable explanation

for these effects would be that the depicted movement facilitated for the subjects the process of "cognitive transformation" in the sense that Guilford used it. Guilford (1967) defined transformations as "changes of various kinds, of existing or known information in its attributes, meaning, role, or use" and included among the most common transformations in figural information "changes in sensory qualities and quantities, in location (movement), and in arrangement of parts."

Little research has been done on the representation or simulation of motion in still pictures. Lumsdaine (1963) reported an unpublished study by Smith and Resnick (1953) showing that "untrained observers were able (1) to differentiate fairly reliably between live drawings of human figures excerpted from a motion sequence and those where the figure was not moving, and (2) to judge speed of motion with some reliability, but with only fair accuracy."

Relationships of Media to Instructional Objectives

There is as yet no firmly established set of rules, guidelines, or principles for the selection of appropriate instructional media to meet specified instructional objectives, and there is little experimental evidence to point the way for the making of instructional decisions. At the same time, a number of attempts are being made to develop a taxonomy of instructional media in relation to the accomplishment of various learning tasks and with various kinds of learners.

Miller (1956) classified behavior into six categories of tasks: perceiving, recalling procedures, recalling nomenclature, interpreting, making logical inferences, and performing manual operations. Bloom and Others (1956) developed a taxonomy of educational objectives categorized into three major domains: cognitive, affective, and psychomotor. The cognitive domain was then subdivided into the knowledge, comprehension, application, analysis, synthesis, and evaluation objectives. Gagné and Bolles (1959) proposed four kinds of tasks having their own peculiar conditions for learning efficiency: identification, following procedures, concept using, and motor skills. Parker and Downs (1961) advanced six military training objectives: learning identifications, learning perceptual discriminations, understanding principles and relationships, learning procedural sequences, making decisions, and performing perceptual-motor acts.

Later, Gagné (1962) classified behavior into sensing, identifying, and interpreting categories. In his book on the conditions of learning, Gagné (1965) identified eight types of learning--signal, stimulus-response, chaining, verbal association, multiple-discrimination, concept, principle, and problem solving--and eight functions of the instructional situation that must be performed by its components--presenting the stimulus, directing attention, providing a model of expected performance, furnishing external prompts, guiding thinking, in-

ducing transfer, assessing attainments, and providing feedback.

Several attempts have been made to assign specific media to the accomplishment of the different instructional objectives. Parker and Downs (1961) considered the appropriateness of five different classes of training media for the accomplishment of six different military training objectives. The five classes of training media--simulators, training devices, training aids, teaching machines or automated training systems, and training parts--set forth by Parker and Downs are differentiated by their physical characteristics as pieces of equipment rather than by their perceptual or psychological attributes. As a result, this classification scheme for media application has little relevance to the present study. Gagné (1965) made a more determined effort to relate selected media to the component functions of the instructional situations and rated each of the media--objects, demonstrations, oral communication, printed, still pictures, moving pictures, sound movies, and teaching machines--as to its ability to perform each function. Allen (1967) also attempted to rate a number of common instructional media types in relation to six learning objectives: learning factual information, learning visual identifications, learning principles, concepts and rules, learning procedures, performing skilled perceptual-motor acts, and developing desirable attitudes, opinions and motivations. The most intensive effort to bring together what is known about media characteristics and effectiveness as related to types of learning in the preparation of actual instructional units was made by Briggs and Others (1967). They set forth a step-by-step procedure for choosing appropriate media. As yet, however, little evidence is available to help us make the right media decisions. The present study is one of the first of its kind to attempt some investigation in depth of the relationships of different media to defined instructional objectives.

Relationships of Media to Subject Matter Content

The evidence from previous research supports the conclusion that visual materials, motion picture and still, can make significant contributions to cognitive learning regardless of the subject matter content. However, no research results are available that show differential effects of various types of visual presentations for the different subject matter areas.

Relationships of Media to Learner Characteristics

There is little evidence bearing directly on the question of media-learner relationships. Although some past research attention has been given to the relationships of mental ability to learning from different kinds of instructional media (Hoban and van Ormer, 1950; Allen, 1960), little study has been made of the relationships of various

learner characteristics to more specific design characteristics of the media or to the instructional objective for which the communication is employed.

Allen, Filep and Cooney (1967), using a battery of tests based on Guilford's (1967) structure-of-intellect model and selected to measure "figural" ability, found no apparent relationship between the subjects' "figural" aptitude and the learning of content having different kinds of visual, audio, structural, or content inherency characteristics. Using a similar battery of tests, Allen and Daehling (1968) found no relationships to these structure-of-intellect factors and the mode of visual presentation of still pictorial material characterized as being figural, symbolic, or semantic in content and form of presentation. Similarly, Gagné and Gropper (1964) had examined individual differences of eighth graders in learning from visual and verbal presentations and found no correlations between spatial aptitude and learning with pictorial representation. Although the above-cited studies relate to intellectual factors not considered in the present study, they do point out the relationship of one aspect of mental ability to the form of medium used.

There is evidence from a number of studies, as reported by Allen (1960), that students of high intelligence usually learn more from visual presentations than those of medium or low intelligence. In addition, in many cases, those of lower intelligence appear to make a greater increment in learning when exposed to visual rather than verbal stimuli. In a recent study, Gropper (1966) found a significant relationship between IQ and mode of presentation, the higher ability subject profiting more from the verbal presentation of science concepts and principles than from the visual presentation and the lower ability subjects profiting more from the visual presentation. The only study known to the researchers that compared learning from motion and still pictorial presentations for groups with different learner characteristics was that made by Allen, Cooney and Weintraub (1968). They found no differences in criterion achievement between motion and still presentation for either high and low non-language IQ or for high and low vocabulary ability groups. In each case, however, the higher ability groups performed at a significantly higher level than the lower ability groups.

CHAPTER II

METHOD AND PROCEDURES

Controlled experimentation was used to assess the effects of the motion variable upon the learning of cognitive information in different content areas and used for meeting different instructional objectives.

Experimental Design and Method

Experimental Design

The design of the study called for the development of the 81 experimental treatments described below, the administration of these treatments to experimental subjects under controlled conditions, the testing of the performance of the subjects by means of posttests of information given immediately following exposure to the stimulus materials, and the comparison of the performance data by means of appropriate statistical techniques.

Three parallel experiments, consisting of nine separate instructional sequences each, were conducted, and involved different subject matter content: science, motor skills, and social studies. In each experiment, three of the instructional sequences were designed to meet each of three instructional objectives: knowledge of specific facts, serial ordering, and learning of concepts. All 27 of these instructional sequences were produced in three alternate visual presentation modes: motion picture, sequenced still pictures, and single still pictures. The model for the study is graphically displayed in Figure 1.

Subjects were 582 fifth and sixth grade students from the Bellflower Unified School District (California), assigned at random to the different instructional treatments.

Comparisons of the performance on each of the instructional sequences were made by one-way analysis of variance technique for the total performance scores and for each of the performance test items. In addition, comparisons of performance were made separately for the high and low mental ability groups and for boys and girls. Qualitative reactions of the subjects to the treatment modes were also obtained and correlated with performance test scores.

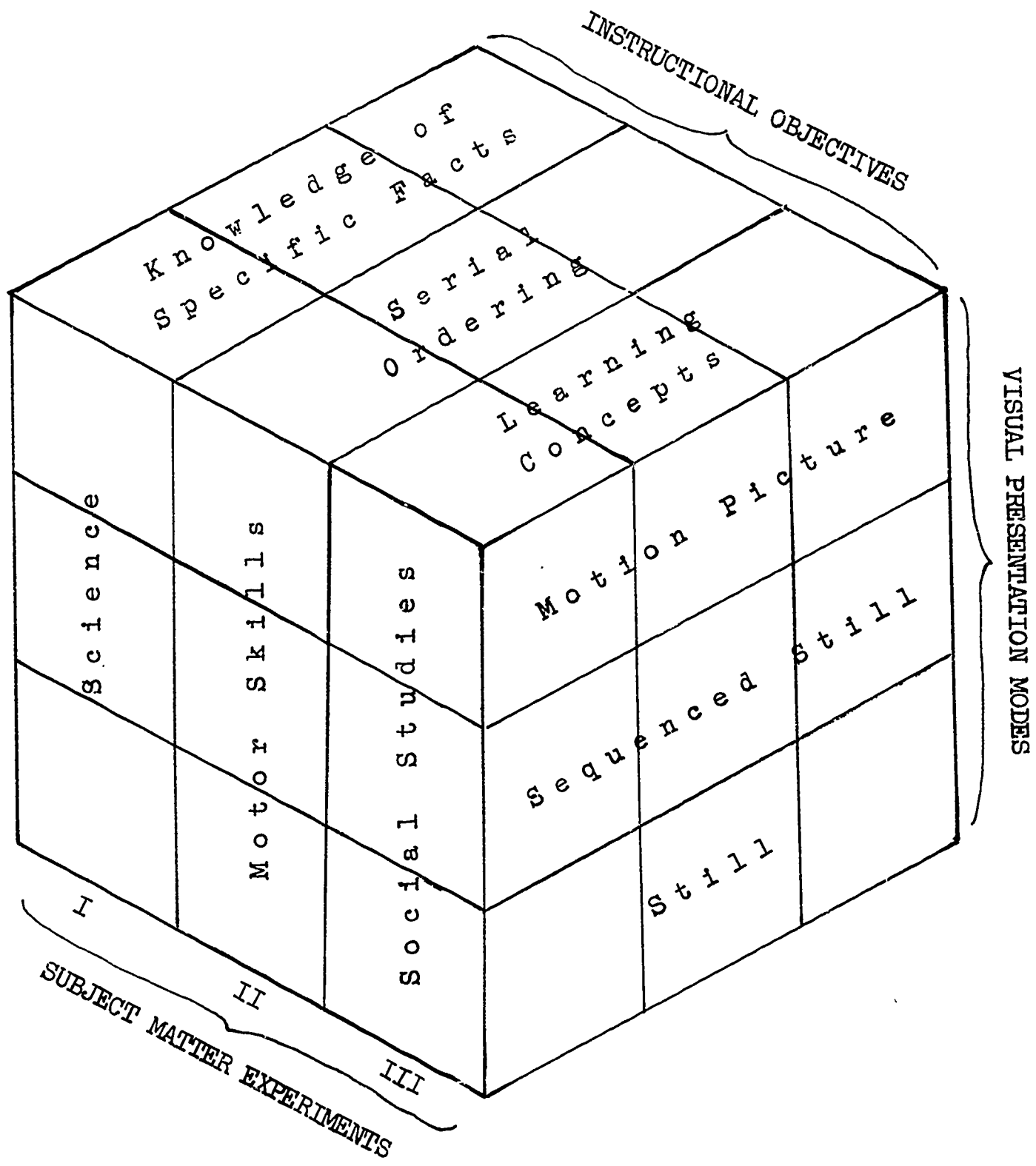

Figure 1 - Model of Experimental Design

A posttest-only design without a control group was used, because the study was testing hypotheses concerning which of several treatments produced the greater effects and was not concerned with the question of whether the treatments were more effective than no treatment at all.

Experimental Variables

Visual Presentation Modes. Three different methods of presenting the visual instructional stimulus materials were compared:

1. Motion Picture, in which silent sequences of live motion picture photography and animated graphics were presented in full continuous motion. These sequences were selected from 8mm silent single concept films and were edited to eliminate non-essential shots and verbal material. Presentation to subjects was made by means of a motion picture projector.
2. Sequenced Still Pictures, in which the content of the motion pictures films were sampled at frequent intervals in order to simulate motion and to serve as a transitional mode between full motion and the single still pictures. The sampling varied according to the amount of motion inherency in the original motion picture sequences. Where there was a great deal of motion, sampling was frequent (sometimes faster than one frame per second), but when motion was minimal, the sampling time was decreased accordingly. Presentation to subjects was made by means of an automatic filmstrip projector.
3. Still Pictures, in which the content of the motion picture films were sampled only at key visual points. A new still picture was chosen each time a completely new visual image was presented or the gross change within a shot required additional pictures to comprehend the basic changes taking place. This mode was comparable to still slide or filmstrip projection. Presentation to subjects was by means of a slide projector.

Subject Matter Content. Three different subject matter content areas were selected, each comprising the substance of separate experiments:

1. Science, in which subject matter was selected that gave a cross section of the scientific field. The content included instructional sequences on nuclear reactions, cell growth, learning of contours in geography, plant growth, filtering of solids from liquids, the oscillation of a suspension bridge, work done by steam, the formation of dome and volcanic mountains, and the scientific principles applied in centrifugal force.
2. Motor Skills, in which subject matter from the motor skill area was selected for the purpose of cognitive learning (not motor

skill performance). The content included instructional sequences on tumbling, slide and motion picture projector threading and adjustment, the shot put, the making of clay beads, acrobatic work on the trampoline, the capture of different gestures by drawing, and the making of experimental paintings.

3. Social Studies, in which subject matter from the social studies area was selected. The content included instructional sequences on irrigation in Egypt, the African city and village, the floating markets of Thailand, banana and copra harvesting, lumbering, contrasts of Eastern Europe with Middle America, and transportation in India.

Instructional Objectives. Three different instructional objectives were selected for testing within each subject matter content area:

1. Knowledge of Specific Facts, in which the subjects were asked to recall specific information such as number, amount, and identification of visuals presented.

2. Serial Ordering, in which the subjects were required to serially organize into the proper step-by-step order objects, events, and procedures. This was done by indicating which came first, second, third, and so forth. This was the type of knowledge needed in being able to perform procedural acts.

3. Learning Concepts, in which the subjects were required to abstract the principles or generalizations within a presentation.

Learner Variables

The above three experimental variables were studied in relation to the following learner variables:

Mental Ability, or the intellectual factors as measured by standardized tests of mental maturity and categorized for the purposes of this study as High (above the mean) and Low (below the mean).

Sex, in which the population was subdivided into boys and girls for separate analysis.

Experimental Population

The total experimental population consisted of 582 subjects drawn from four elementary schools in the Bellflower Unified School District (California). There were 248 fifth grade subjects (106 male and 142 female) and 334 sixth grade subjects (175 male and 159 female) used in the study. The subjects used comprised the total fifth and

sixth grade populations of these schools, with those students eliminated who were below fourth grade in reading ability or for whom there was no standardized test data available.

The subjects were distributed to the experimental treatments in each of the schools and for each sex separately by using a table of random numbers. Analyses of variance were performed to determine if the distribution of the subjects to the experimental treatments, based on Verbal SCAT scores for the fifth grade subjects and Verbal Lorge-Thorndike scores for the sixth grade subjects, had been random. The mean scores, standard deviations, and homogeneity of the means for these comparisons are presented in Table 1. The F values of the six analyses of variance (3 subject matter areas x 2 grade levels) were not statistically significant at the .05 level, confirming the validity of the randomization procedure and attesting to the comparability of the treatment groups on the learner characteristics measured.

Development of the Experimental Stimulus Materials

A total of 81 separate experimental treatments were produced in accordance with the requirements of the variables being studied. One-third, or 27 treatments were produced in motion picture form, one-third in sequenced still picture form, and one-third in still picture form. All treatment versions were designed to be presented without accompanying sound. Selected examples of these treatments are presented in Chapter III, Figures 2 through 10.

The topics utilized for the experimental treatments met several requirements: (1) The content had to be comprehensible to the subjects yet provide sufficiently novel information to minimize effects of prior knowledge and to permit the construction of a range of test items; (2) the visual elements had to contain all essential information, because they were presented silently in order to control for the possible interactive effects of audio accompaniment; (3) the content had to be presented within a short period of time; and (4) the material selected had to contain a sufficiently high motion inherency to allow for comparisons of the motion and still presentation effects.

The selection of the subject matter to be used in the study and the preparation of the experimental stimulus materials followed the development of a preliminary taxonomy of subject matter content/instructional objectives relationships.

Development of the Preliminary Content/Objectives Taxonomy

After intensive review of the research and the viewing of 368 instructional films, a preliminary working taxonomy of subject matter

TABLE 1

MEAN SCORES, STANDARD DEVIATIONS, AND HOMOGENEITY OF MEANS
FOR VERBAL MENTAL ABILITY* SCORES
(Analysis of Variance)

	Science			Motor Skills			Social Studies		
	N	\bar{X}	σ	N	\bar{X}	σ	N	\bar{X}	σ
FIFTH GRADE									
Motion Picture	27	57.000	19.882	29	55.897	22.563	33	59.515	20.942
Sequenced	22	52.682	16.726	31	54.645	18.400	28	57.000	20.020
Still	19	60.000	21.429	28	53.286	22.423	31	57.065	18.406
SIXTH GRADE									
Motion Picture	37	100.784	14.125	41	102.732	14.367	33	100.636	14.635
Sequenced	39	101.410	12.182	37	99.432	12.872	38	103.632	11.481
Still	37	99.189	12.101	36	106.000	11.519	36	102.000	11.374

	df	SS	MS	F	Prob.
FIFTH GRADE					
<u>Science</u>					
Between Means	2	559.992	279.996	.745	NS
Within Groups	65	24418.773	375.673		
Total	67	24978.765			
<u>Motor Skills</u>					
Between Means	2	97.124	48.562	.109	
Within Groups	85	37987.501	446.912		
Total	87	38084.625			
<u>Concepts</u>					
Between Means	2	130.354	65.177	.166	NS
Within Groups	89	35020.113	393.484		
Total	91	35150.467			
SIXTH GRADE					
<u>Science</u>					
Between Means	2	98.813	49.406	.300	NS
Within Groups	110	18093.382	164.489		
Total	112	18192.195			
<u>Motor Skills</u>					
Between Means	2	787.125	393.562	2.316	NS
Within Groups	111	18865.130	169.956		
Total	113	19652.254			
<u>Concepts</u>					
Between Means	2	159.821	79.910	.511	NS
Within Groups	104	16258.478	156.332		
Total	106	16418.299			

*Mental ability was measured by the SCAT for fifth grade groups and the
Large-Thorndike for the sixth grade groups.

content/instructional objectives relationships was devised. This tentative taxonomy served as a working model for the structuring of the experimental treatments.

The three subject matter content area identified for study--science, motor skills, and social studies--seemed to represent three content areas that were important in elementary school instruction and for which a large range of existing motion pictures were available. Although the selection of the subject matter areas was arbitrary, and could well have substituted other subject matters for those chosen, the three subject matter areas did provide a source of content that could be studied in interaction with the instructional objectives that were selected. It should be noted that the different subject matters available for study is large and that a selection needed to be made for this study.

The three instructional objectives identified for study--knowledge of specific facts, serial ordering and learning concepts--appeared to be consistent with the types of tasks and objectives reviewed in Chapter I. Again, the objectives studied were not all inclusive, but were selected from a range of possibilities. They did, however, represent instructionally important tasks or learning behaviors that might be expected to interact both with subject matter content and the visual mode employed to present them to learners.

Subject Matter

With the decision made to utilize subject matter in the science, motor skill, and social studies areas, curriculum guides were examined to determine specific topics studied in the elementary grades. It was necessary to select material that was unfamiliar to the intermediate grade students but within their range of comprehension. The material selected also needed to be available to 8mm film form. After extensive previewing of materials, commercially-produced films were selected to be used in the experiment. These films are listed in Appendix A.

Experimental Materials Production

The experimental visual stimulus materials were presented as single frame 2" x 2" transparency slides, 35mm filmstrips, and 8mm motion picture films. All three presentations had approximately the same aspect ratio, providing equivalent amounts of visual information. All materials were produced in color.

Motion Picture Films. The motion picture film treatments were edited from commercial 8mm cartridge release prints. Numerous shots were cut down or removed if they were judged to be non-essential to the film's basic message. Both the test validation and the final ex-

perimental presentations were made using normal reel-to-reel motion picture projectors with blank leader separating the different film sequences.

Filmstrips and Slides. The filmstrips and slides were produced by copying separate frames of the final motion picture version. A front projection system for duplicating from the motion pictures to the filmstrips and slides was selected as a compromise between ease of operation and quality of reproduction. A Technicolor 800 Projector was fastened to the base of a copystand table, with an Olympus FT single-frame still camera mounted rigidly to the stand just above and in front of the projector. The image was projected onto a high gloss paper and photographed from this screen. Kodachrome IIA Professional color film was mounted in 2" x 2" slide holders for the slide versions or left unmounted for the filmstrip versions. When more than 72 frames in the filmstrip were required, transparent mylar splices joined the filmstrip segments together. There was some loss in technical quality for the filmstrips and slides resulting from the copying process.

Instrumentation

The experimental stimulus materials were presented on motion picture, filmstrip, and slide projectors with control of the timing and advance made by a pulse track on a control tape recorder unit. Motion pictures were projected with 8mm Kodak M95 Projectors, a zoom lens providing a means for matching image size to that of the still film projectors. Slides were projected with standard Kodak Carousel Model 500 slide projectors. These projectors also had zoom lenses to adjust the picture area size. Filmstrips were projected with Kalart-Victor Model PS65 filmstrip projectors, capable of projecting at rates as high as five frames per second. Front surfaced mirrors were used to correct an image reversal caused by the copystand arrangement used in producing the filmstrips. Light levels for all three kinds of projectors were equalized by the use of appropriate projection lamps.

The slide and filmstrip projectors were controlled by a Cousino Model R-7320 Repeater Tape unit. Tapes were coded to activate the slide and filmstrip changes so as to conform to the exact times of comparable scenes in the motion picture treatments. A switching box was designed to switch power and control pulses to each of the projectors.

The three projectors, control tape recorder, and the switching box were clustered in a two-tier stand at the rear of the rooms.

Measuring Instruments

Performance Tests

A total of 27 performance tests were prepared, one for each

stimulus sequence. The tests are presented in Appendix B. The performance tests consisted of verbal and graphic items employing multiple-choice, true-false, completion fill-in, and ordering questions. The science test consisted of 70 items, the motor skill test of 79 items, and the social studies test of 88 items.

All test items were developed through a tryout-revise-tryout-revise cycle. The first validation field test followed the presentation of the final versions of the motion picture treatments. Fifth and sixth grade students from the same school district, who were not members of the experimental population, participated in the field test. The students in each school were divided into two groups, one group being tested on 14 of the versions and the other group on 13 of the versions. During this phase, patterns of response to stimulus materials, time to complete the programs, and student acceptance of the content were also analyzed. Student performance to the tests were analyzed on a Honeywell 800 computer, using phi and biserial programs provided by the Testing Bureau of the University of Southern California. Revisions were made in the tests on the basis of the first validation test and then tried out again with a second sample of the population under the same conditions. Finally, minor revisions were made as a result of the second tryout before the tests were reproduced in final form.

The reliabilities of the performance tests were separately computed for the two groups in each of the tryouts through the use of Kuder-Richardson Formula #20. In the first tryout, the reliability for one group was .79 and for the other group, .71. The mean score was 70.4 of a possible 141 points for the first group and 48.7 of a possible 111 points for the second group. On the second tryout after the revision of the tests, the reliability for the first group was raised to .90 with a mean score of 84.6 of a possible 149 points. For the second group the reliability was raised to .83 with a mean score of 72.7 of a possible 118 points. During the second validation tryout a control group of subjects who took only the tests and saw none of the films was used. The reliability for this control group was .75 with a mean of 56.8 for the first group and a reliability of .76 with a mean of 53.7 for the second group.

Mental Ability and Achievement Tests

The mental ability of the fifth grade subjects was measured by the Verbal Battery of the School and College Ability Tests (Educational Testing Service, 1957), and the sixth grade subjects by the Verbal Battery (Level D, Form 1) of the Lorge-Thorndike Intelligence Tests (1964).

Scores on the Word Meaning and Paragraph Meaning sections of The Sequential Tests of Educational Progress (Educational Testing Service, 1963) were used to measure verbal achievement in the fifth grade and similar scores on the Intermediate II Battery of the Stanford Achievement Test (Kelley and Others, 1964) were used to measure language ability in the sixth grade.

Attitude Toward Presentation

A five-point student reaction scale (ranging from "very good" to "very bad") was constructed to elicit relative ratings of student reactions to each of the stimulus presentations. This scale preceded the questions for each presentation, and students were instructed to react to the mode in which the material was presented rather than to the actual content.

Conduct of the Experiments

Schedules and procedures were worked out in detail with the administrative staffs of each school and then were reviewed with the teachers of the classes involved in the experiment. At the time of the experimental runs the subjects in the fifth grades met in their regular classrooms and were then taken to one of the three appropriate experimental rooms as determined by their random assignment. Subjects in each experimental room were given the instructions by a member of the experimental staff and were exposed to the nine experimental treatments in the appropriate mode for that group. Following each stimulus treatment the lights in the room were turned on and the subjects completed the test for that material. The lights were then lowered and the next set of materials was presented and tested, followed by the remaining materials using the same procedure. The entire procedure utilized about 75 minutes of time. Following a recess break to permit the rethreading of the stimulus materials, this same procedure was followed with the sixth grade subjects. The fifth and sixth grade subjects were restrained from physical contact during the recess period.

Preparation of Data and Statistical Analysis

Responses to the performance test items were made directly on the tests themselves. After scoring twice to reduce errors, they were transferred to sense-score sheets for mechanical transfer to IBM cards.

Student data cards were obtained directly from the Bellflower Unified School District. These cards provided the mental ability and achievement test data and student identification numbers. These cards, together with the performance test scores were matched and were used in all analyses.

One-way analyses of variance were undertaken to identify the characteristics of the population and to establish the statistical differences among the experimental variables. The analysis of variance computer program used was the "Summary Program," furnishing t-test and one-way analyses of variance (Computer Sciences Laboratory, 1967).

Product moment coefficients of correlation were obtained between the "Attitude Toward Presentation" scale and performance test scores.

All statistical analyses were made on the Honeywell 300 computer, operated by the staff of the Computer Sciences Laboratory, University of Southern California.

CHAPTER III

RESULTS

Test results were analyzed for each of the 27 stimulus sequences separately. This analysis included comparison of results on the total performance tests, on the total performance tests for sex and for mental ability groups, on each test item individually for the total groups, on the attitude toward the stimuli, and on the correlations between attitude toward the stimuli and performance test score.

Analysis of Total Performance

The mean test performance scores for the two grade levels are presented in Tables 2 and 3, and the results of the one-way analyses of variance are presented in Tables 4 and 5. These comparisons are summarized in Table 6.

An examination of these results shows that the motion picture mode resulted in superior learning gains over the two still picture modes in most of the comparisons made. This superiority in raw score learning gains was evident in 19 of the 27 comparisons for the fifth grade and 20 of the 27 comparisons for the sixth grade. Of these numbers, 15 showed a significantly superior advantage for the motion picture mode at the $< .10$ level or better in the fifth grade and 14 in the sixth grade.¹ On only one stimulus sequence at the sixth grade level ("African City" presenting specific facts in the social studies) did a still picture mode show a significant advantage over the motion picture. This was for the still mode at the $< .10$ level. In one case in the fifth grade and in three cases in the sixth grade the still mode showed significant superiority to the sequenced mode, and in only one case at each grade level was the sequenced mode significantly superior to the still mode.

¹The rather low .10 level of significance was selected because of the exploratory nature of the study and because the researchers wished to include any tendencies toward superiority for any of the presentation modes. Of the 58 significant differences reported in this section, only six were at the .10 level.

TABLE 2

TOTAL PERFORMANCE TEST MEAN SCORES AND STANDARD DEVIATIONS
BY TREATMENT GROUPS FOR ALL STIMULI (FIFTH GRADE)

	Motion Picture			Sequenced			Still		
	N	\bar{X}	σ	N	\bar{X}	σ	N	\bar{X}	σ
SCIENCE									
<u>Specific Facts</u>									
Nuclear Reactions	27	2.74	1.81	22	2.46	1.50	19	3.05	1.81
Cells	22	3.86	1.83	19	3.74	1.88	27	2.96	1.63
Contours	19	4.21	1.62	27	3.59	1.39	22	3.00	1.45
<u>Serial Ordering</u>									
Plants	27	5.67	2.97	22	1.86	1.75	19	2.00	2.33
Filtering	22	9.59	2.77	19	7.74	3.03	27	6.41	2.34
Tacoma Bridge	19	5.11	2.66	27	4.15	2.20	22	4.91	2.25
<u>Concepts</u>									
Steam	27	2.78	.97	22	2.05	2.21	19	1.84	1.21
Dome & Volcanic Mts.	22	2.68	1.21	19	3.00	.82	27	3.07	1.11
Amusement Park	19	2.11	.88	27	2.37	.93	22	2.14	1.17
MOTOR SKILLS									
<u>Specific Facts</u>									
Tumbling	29	4.14	2.23	31	4.77	2.66	28	4.86	2.58
Slide Projector	31	5.68	1.76	28	4.61	1.52	29	5.93	1.52
Shot Put	28	2.64	1.13	29	2.79	1.08	31	2.10	1.08
<u>Serial Ordering</u>									
Clay Beads	29	6.28	1.98	31	4.87	1.75	28	5.14	1.84
Bird's Nest/Cartwheel	31	5.26	2.76	28	4.07	2.73	29	4.52	3.08
Motion Picture Projector	28	4.25	1.48	29	3.62	1.76	31	3.07	1.77
<u>Concepts</u>									
Gesture	29	4.90	1.80	31	4.52	1.48	28	4.07	1.44
Trampoline	31	6.65	1.82	28	6.61	2.30	29	6.69	1.76
Experimental Painting	28	2.14	1.38	29	1.76	.79	31	2.07	1.09
SOCIAL STUDIES									
<u>Specific Facts</u>									
Egypt Irrigation	33	5.82	1.39	28	4.07	1.05	31	4.36	1.33
African City	28	7.82	1.19	31	7.58	1.54	33	7.36	1.77
Floating Market	31	8.52	2.01	33	7.46	1.77	28	7.04	2.12
<u>Serial Ordering</u>									
Banana Harvesting	33	6.72	2.13	28	3.43	2.12	31	3.84	2.04
Copra	28	5.29	2.05	31	3.65	1.78	33	3.97	1.65
Lumbering	31	7.23	2.35	33	5.73	2.54	28	5.93	2.16
<u>Concepts</u>									
African Village	33	8.52	2.18	28	7.36	2.08	31	7.07	2.38
East. Europe/Midd. America	28	4.04	3.50	31	4.84	3.73	33	4.94	4.34
Transportation in India	31	6.39	1.50	33	6.76	1.48	28	6.64	1.37

TABLE 3

TOTAL PERFORMANCE TEST MEAN SCORES AND STANDARD DEVIATIONS
BY TREATMENT GROUPS FOR ALL STIMULI (SIXTH GRADE)

	Motion Picture			Sequenced			Still		
	N	\bar{X}	σ	N	\bar{X}	σ	N	\bar{X}	σ
SCIENCE									
<u>Specific Facts</u>									
Nuclear Reactions	37	3.35	1.78	39	4.10	1.71	37	3.24	1.82
Cells	39	4.00	1.79	37	3.51	1.76	37	3.62	1.82
Contours	37	3.73	1.59	37	3.73	1.90	39	4.36	1.60
<u>Serial Ordering</u>									
Plants	37	5.05	3.10	39	3.15	2.52	37	2.43	1.85
Filtering	39	11.00	2.90	37	7.84	3.19	37	6.87	2.23
Tacoma Bridge	37	5.51	1.98	37	4.38	1.83	39	4.49	1.83
<u>Concepts</u>									
Steam	37	3.11	1.31	39	2.31	1.28	37	2.05	1.31
Dome & Volcanic Mts.	39	3.33	1.18	37	2.84	1.19	37	2.81	1.22
Amusement Park	37	2.24	.96	37	2.11	1.13	39	2.36	.84
MOTOR SKILLS									
<u>Specific Facts</u>									
Tumbling	41	14.02	2.39	37	12.49	2.58	36	13.50	2.69
Slide Projector	37	5.43	1.86	36	5.03	1.81	41	5.95	1.50
Shot Put	36	3.11	1.12	41	2.56	1.25	37	2.49	.84
<u>Serial Ordering</u>									
Clay Beads	41	5.85	2.13	37	5.22	2.14	36	5.33	2.00
Bird's Nest/Cartwheel	37	5.78	2.69	36	3.22	2.32	41	5.17	2.73
Motion Picture Projector	36	5.00	1.69	41	4.24	1.93	37	3.54	2.13
<u>Concepts</u>									
Gesture	41	5.20	1.87	37	4.43	1.69	36	4.33	1.76
Trampoline	37	6.51	1.76	36	6.86	1.62	41	6.90	1.69
Experimental Painting	36	2.06	1.12	41	2.05	1.28	37	1.92	1.09
SOCIAL STUDIES									
<u>Specific Facts</u>									
Egypt Irrigation	33	6.03	1.10	38	4.97	1.37	36	4.28	1.85
African City	38	7.79	1.28	36	7.42	1.25	33	8.33	1.45
Floating Market	36	9.17	1.86	33	7.55	1.73	38	7.45	1.97
<u>Serial Ordering</u>									
Banana Harvesting	33	6.76	2.22	38	4.66	2.33	36	3.92	1.86
Copra	38	5.26	1.55	36	4.83	1.72	33	4.67	1.61
Lumbering	36	7.39	2.85	33	7.06	2.08	33	6.21	2.22
<u>Concepts</u>									
African Village	33	9.03	1.51	38	7.79	1.88	36	7.39	1.75
East. Europe/Midd. America	38	8.50	4.01	36	8.36	4.50	33	7.24	4.38
Transportation in India	36	7.03	1.54	33	7.06	1.32	38	6.90	1.89

TABLE 4
RESULTS OF ANALYSIS BY TREATMENT GROUPS FOR ALL STIMULI (FIFTH GRADE)

	Analysis of Variance			t-test Comparisons
	df	F	Prob.	
<u>SCIENCE</u>				
<u>Specific Facts</u>				
Nuclear Reactions	2/65	.619	--	
Cells	2/65	1.871	--	
Contours	2/65	3.431	<.05	MP/St.05*
<u>Serial Ordering</u>				
Plants	2/65	18.865	<.001	MP/Seq.001;MP/St.001
Filtering	2/65	8.514	<.001	MP/Seq.10;MP/St.001
Tacoma Bridge	2/65	1.105	--	
<u>Concepts</u>				
Steam	2/65	4.355	<.025	MP/Seq.05;MP/St.01
Dome & Volcanic Mts.	2/65	.874	--	
Amusement Park	2/65	.510	--	
<u>MOTOR SKILLS</u>				
<u>Specific Facts</u>				
Tumbling	2/85	2.741	<.10	MP/Seq.05;MP/St.05
Slide Projector	2/85	5.402	<.01	MP/Seq.02;St/Seq.01
Shot Put	2/85	3.380	<.05	MP/St.10;Seq/St.02
<u>Serial Ordering</u>				
Clay Beads	2/85	4.753	<.025	MP/Seq.01;MP/St.05
Bird's Nest/Cartwheel	2/85	1.304	--	
Motion Picture Proj.	2/85	3.662	<.05	MP/St.01
<u>Concepts</u>				
Gesture	2/85	1.944	--	
Trampoline	2/85	.013	--	
Experimental Painting	2/85	.966	--	
<u>SOCIAL STUDIES</u>				
<u>Specific Facts</u>				
Egypt Irrigation	2/89	17.079	<.001	MP/Seq.001;MP/St.001
African City	2/89	.675	--	
Floating Market	2/89	4.538	<.025	MP/Seq.05;MP/St.01
<u>Serial Ordering</u>				
Banana Harvesting	2/89	23.262	<.001	MP/Seq.001;MP/St.001
Copra	2/89	6.614	<.005	MP/Seq.01;MP/St.01
Lumbering	2/89	3.688	<.05	MP/Seq.05;MP/St.05
<u>Concepts</u>				
African Village	2/89	3.823	<.05	MP/Seq.05;MP/St.02
East. Europe/Midd. Amer.	2/89	.474	--	
Transportation in India	2/89	.539	--	

*This should be read: "The Motion Picture treatment was superior to the Still treatment at the .05 level of significance as compared by t-test."

TABLE 5
RESULTS OF ANALYSIS BY TREATMENT GROUPS FOR ALL STIMULI (SIXTH GRADE)

	Analysis of Variance			t-test Comparisons
	df	F	Prob.	
<u>SCIENCE</u>				
<u>Specific Facts</u>				
Nuclear Reactions	2/110	.189	--	
Cells	2/110	.780	--	
Contours	2/110	1.751	--	
<u>Serial Ordering</u>				
Plants	2/110	10.536	<.001	MP/Seq.01;MP/St.001*
Filtering	2/110	22.723	<.001	MP/Seq.001;MP/St.001
Tacoma Bridge	2/110	4.123	<.025	MP/Seq.02;MP/St.05
<u>Concepts</u>				
Steam	2/110	6.651	<.005	MP/Seq.01;MP/St.01
Dome & Volcanic Mts.	2/110	2.317	--	
Amusement Park	2/110	.624	--	
<u>MOTOR SKILLS</u>				
<u>Specific Facts</u>				
Tumbling	2/111	3.620	<.05	MP/Seq.01
Slide Projector	2/111	2.781	<.10	St/Seq.05
Shot Put	2/111	3.626	<.05	MP/Seq.05;MP/St.02
<u>Serial Ordering</u>				
Clay Beads	2/111	1.201	--	
Bird's Nest/Cartwheel	2/111	9.729	<.001	MP/Seq.001;St/Seq.01
Motion Picture Proj.	2/111	5.227	<.01	MP/Seq.10;MP/St.01
<u>Concepts</u>				
Gesture	2/111	2.758	<.10	MP/Seq.10;MP/St.05
Trampoline	2/111	.603	--	
Experimental Painting	2/111	.161	--	
<u>SOCIAL STUDIES</u>				
<u>Specific Facts</u>				
Egypt Irrigation	2/104	12.218	<.001	MP/Seq.001;MP/St.001
African City	2/104	4.155	<.025	St/MP.10;St/Seq.01
Floating Market	2/104	9.675	<.001	MP/Seq.001;MP/St.001
<u>Serial Ordering</u>				
Banana Harvesting	2/104	16.087	<.001	MP/Seq.001;MP/St.001
Copra	2/104	1.290	--	
Lumbering	2/104	2.358	<.10	MP/St.05;Seq/St.10
<u>Concepts</u>				
African Village	2/104	8.393	<.001	MP/Seq.01;MP/St.001
East. Europe/Midd. Amer.	2/104	.886	--	
Transportation in India	2/104	.108	--	

*This should be read: "The Motion Picture treatment was superior to the Sequenced treatment at the .01 level and the Still treatment at the .001 level of significance as compared by t-test."

TABLE 6

SUMMARY OF SIGNIFICANT DIFFERENCES AMONG TREATMENT GROUPS
FOR CONTENT AREAS AND INSTRUCTIONAL OBJECTIVES

FIFTH GRADE	Science	Motor Skills	Social Studies	Total	
Specific Facts	MP/St (1)*	MP/Seq (3) MP/St (1) Seq/St (1) St/Seq (1)	MP/Seq (2) MP/St (2)	MP/Seq (5) MP/St (4) Seq/St (1) St/Seq (1)	
Serial Ordering	MP/Seq (2) MP/St (2)	MP/Seq (1) MP/St (2)	MP/Seq (3) MP/St (3)	MP/Seq (6) MP/St (7)	
Concepts	MP/Seq (1) MP/St (1)		MP/Seq (1) MP/St (1)	MP/Seq (2) MP/St (2)	
Total	MP/Seq (3) MP/St (4)	MP/Seq (4) MP/St (3) Seq/St (1) St/Seq (1)	MP/Seq (6) MP/St (6)	MP/Seq (13) MP/St (13) Seq/St (1) St/Seq (1)	

SIXTH GRADE	Science	Motor Skills	Social Studies	Total	Total (Both Grades)
Specific Facts		MP/Seq (2) MP/St (1) St/Seq (1)	MP/Seq (2) MP/St (2) St/MP (1) St/Seq (1)	MP/Seq (4) MP/St (3) St/MP (1) St/Seq (2)	MP/Seq (9) MP/St (7) Seq/St (1) St/MP (1) St/Seq (3)
Serial Ordering	MP/Seq (3) MP/St (3)	MP/Seq (2) MP/St (1) St/Seq (1)	MP/Seq (1) MP/St (2) Seq/St (1)	MP/Seq (6) MP/St (6) Seq/St (1) St/Seq (1)	MP/Seq (12) MP/St (13) Seq/St (1) St/Seq (1)
Concepts	MP/Seq (1) MP/St (1)	MP/Seq (1) MP/St (1)	MP/Seq (1) MP/St (1)	MP/Seq (3) MP/St (3)	MP/Seq (5) MP/St (5)
Total	MP/Seq (4) MP/St (4)	MP/Seq (5) MP/St (3) St/Seq (2)	MP/Seq (4) MP/St (5) Seq/St (1) St/MP (1) St/Seq (1)	MP/Seq (13) MP/St (12) Seq/St (1) St/MP (1) St/Seq (3)	
TOTAL (Both Grades)	MP/Seq (7) MP/St (8)	MP/Seq (9) MP/St (6) Seq/St (1) St/Seq (3)	MP/Seq (10) MP/St (11) Seq/St (1) St/MP (1) St/Seq (1)		MP/Seq (26) MP/St (25) Seq/St (2) St/MP (1) St/Seq (4)

*This should be read: "At the fifth grade level in presenting specific facts in science, the Motion Picture version was superior to the Still picture version at < .10 level in one instance out of three."

Subject Matter Content

The superiority of the motion picture mode over the two still picture modes occurs about equally, with a tendency for a greater number of significant differences among the treatments to appear in the social studies area. It would appear, however, that there was little or no interaction between the mode of visual presentation studied and the nature of the subject matter being communicated.

Instructional Objectives

The superiority of the motion picture mode over the two still picture modes also prevailed for materials used to meet the three different instructional objectives. However, the fewest number of significant differences at both grade levels was found for the learning of concepts, only 10 as compared to 21 for the learning of specific facts and 27 for serial ordering. It would appear that concept learning, regardless of subject matter content was less subject to influence by the mode of visual presentation than either the learning of specific facts or the cognitive ordering of the content in a sequential way. On the other hand, the serial ordering of the content seemed to be most uniformly affected by the mode of visual presentation, the motion picture mode showing a significant superiority to the still picture modes with seven of the nine stimulus sequences at each grade level. In the learning of specific facts there was greater variability in the effects of the still picture modes when compared with their effects in meeting the other instructional objectives.

Interaction Between Subject Matter Content and Instructional Objectives

An examination of the Table 6 summary discloses two areas where there may be interactions between the subject matter content of the stimuli and the instructional objective being served as they related to the mode of visual presentation used. There appeared to be little difference in effects of the three presentation modes in the learning of specific facts in science (only one significant difference occurring in the fifth grade) or in the learning of concepts in the motor skill content (only two differences occurring in the sixth grade at a low level of significance).

Grade Level

In general, about the same pattern of performance resulted for both the fifth and sixth grade subjects. Of the 19 stimulus sequences on which statistically significant differences occurred, 11 were identical in the two grade levels. Only three comparisons showed significantly different results.

Motion Picture vs Still Mode

There were practically no differences in the patterns of superiority of the motion picture mode over either the sequenced still mode or the still mode. This uniform effect prevailed for the subject matter content, instructional objectives, and grade level. In other words, the motion picture mode was superior to the sequenced still mode about as many times, and in about the same relationships, as it was to the still mode.

Sequenced Still vs Still Mode

There was a slight tendency for the still picture mode to be superior to the sequenced still mode more often (four comparisons) than the reverse (two comparisons). On the whole, however, it would appear that these differences were not significant and that these modes of presentation were practically equivalent for the different subject matter content, instructional objectives, and grade levels.

Conclusions

The analysis of the performance on the total tests for each of 27 stimulus sequences resulted in the following conclusions:

1. The motion picture mode of visual presentation was superior to the sequenced and still picture modes on 70% of the stimulus sequences for the fifth grade and 74% for the sixth grade.
2. The superiority of the motion picture mode prevailed regardless of subject matter content, the instructional objective being served, the interaction between content and objectives, or the grade level of the subjects.
3. It appeared that concept learning, regardless of the subject matter content, was less subject to influence by the mode of visual presentation than either the learning of specific facts or of serial ordering.
4. The serial ordering of the content seemed to be most susceptible to influence by the motion picture mode of visual presentation.
5. The mode of visual presentation seemed to have the least influence upon performance in presenting specific facts in science and concepts in motor skill content.
6. About the same pattern of performance resulted for the two grade levels.

7. There appeared to be no practical differences in the effectiveness of the two still picture modes of visual presentation.

Analysis by Learner Characteristics

Analyses were made of two learner characteristics in order to determine whether or not there was a learning differential in the way different types of learners responded to the different experimental treatments. The learner characteristics selected for analysis were Sex and Mental Ability.

Sex

The analysis of the performance by the male and female subjects is summarized in Table 7 for both the fifth and sixth grade groups. In Tables 12 and 13 in Appendix C the total performance test mean scores are presented for the two sex groups, and in Tables 14 and 15 in Appendix C the results of the analyses of variance for both groups are presented.

The sex of the subjects did not appear to interact with any of the visual presentation modes or subject matter content areas to produce differences in test performance. A number of significant differences were observed for one or the other of the sex groups, but, where significant differences occurred for both male and female groups, they were always in the same direction. This consistency of response held for both grade levels.

Neither sex deviated from the pattern of the major analyses of the combined groups, in which the presentation of specific facts in science and concepts in motor skill content appeared to be least influenced by mode of visual presentation.

The only noticeable sex difference in performance was that associated with the cognitive learning of motor skills. The stimulus sequences in which significant differences were found for the girls outnumbered those for the boys over two to one. This was most apparent in serial ordering, and probably most of the variance with this objective was contributed by the girls.

Mental Ability

The analysis of performance by subjects with high and low mental ability is summarized in Table 8 for both the fifth and sixth grade groups. In Tables 16 and 17 in Appendix C the total performance test mean scores are presented for the two mental ability groups, and in Tables 18 and 19 in Appendix C the results of the analyses of variance for both groups are presented.

TABLE 7

SUMMARY OF SIGNIFICANT DIFFERENCES (t-TEST) AMONG TREATMENTS FOR MALE AND FEMALE GROUPS

	Fifth Grade				Sixth Grade			
	Male		Female		Male		Female	
<u>SCIENCE</u>								
<u>Specific Facts</u>								
Nuclear Reactions			St/Seq					
Cells			.05*					
Contours	MP/St							
	.10							
<u>Serial Ordering</u>								
Plants	MP/Seq	MP/St	MP/Seq	MP/St	MP/St	MP/Seq	MP/St	
	.05	.05	.001	.001	.10	.01	.001	
Filtering	MP/Seq	MP/St	MP/St		MP/Seq	MP/St	MP/Seq	MP/St
	.10	.01	.02		.001	.001	.05	.01
Tacoma Bridge					MP/Seq	MP/St		
					.01	.10		
<u>Concepts</u>								
Steam			MP/Seq	MP/St	MP/Seq	MP/St		
			.01	.05	.05	.001		
Dome & Volcanic Mts.	St/Seq		Seq/MP		MP/Seq	MP/St		
	.05		.05		.10	.05		
Amusement Park								
<u>MOTOR SKILLS</u>								
<u>Specific Facts</u>								
Tumbling	MP/Seq	MP/St			MP/St	MP/Seq	St/Seq	
	.10	.10			.10	.05	.02	
Slide Projector	St/Seq		MP/Seq	St/Seq			St/Seq	
	.05		.05	.10			.02	
Shot Put			MP/St	St/Seq	MP/St	MP/Seq	MP/St	
			.01	.05	.10	.10	.10	
<u>Serial Ordering</u>								
Clay Beads			MP/Seq	MP/St				
			.10	.10				
Bird's Nest/Cartwheel			MP/Seq		MP/Seq	St/Seq	MP/Seq	St/Seq
			.02		.01	.01	.02	.10
Motion Picture Proj.			MP/St	Seq/St			MP/Seq	MP/St
			.001	.02			.05	.01
<u>Concepts</u>								
Gesture							MP/St	
							.10	
Trampoline								
Experimental Painting			MP/Seq	St/Seq				
			.10	.10				
<u>SOCIAL STUDIES</u>								
<u>Specific Facts</u>								
Egypt Irrigation	MP/Seq	MP/St	MP/Seq	MP/St			MP/Seq	MP/St
	.01	.05	.001	.01			.001	.001
African City							MP/Seq	St/MP
							.05	.10
Floating Market	MP/Seq	MP/St			MP/Seq		MP/Seq	MP/St
	.10	.05			.05		.01	.001
<u>Serial Ordering</u>								
Banana Harvesting	MP/Seq	MP/St	MP/Seq	MP/St	MP/Seq	MP/St	MP/Seq	MP/St
	.01	.05	.001	.001	.05	.001	.02	.01
Copra	MP/Seq	MP/St						
	.02	.10						
Lumbering	MP/Seq							
	.10							
<u>Concepts</u>								
African Village	MP/St		MP/Seq		MP/St		MP/Seq	MP/St
	.05		.01		.02		.01	.01
East. Europe/Midd. Amer.								
Transportation in India								

*This should be read: "The Still picture mode was superior to the Sequenced mode at < .05 level of significance as compared by t-test."

TABLE 8

SUMMARY OF SIGNIFICANT DIFFERENCES (t-TEST) AMONG TREATMENTS
FOR HIGH AND LOW MENTAL ABILITY GROUPS

	Fifth Grade				Sixth Grade					
	High		Low		High			Low		
<u>SCIENCE</u>										
<u>Specific Facts</u>										
Nuclear Reactions									MP/Seq	
Cells			MP/St	Seq/St*					.10	
Contours			.05	.10						
<u>Serial Ordering</u>										
Plants	MP/Seq	MP/St	MP/Seq	MP/St	MP/Seq	MP/St			MP/St	
	.01	.01	.01	.01	.001	.001			.10	
Filtering	MP/St		MP/St		MP/Seq	MP/St			MP/Seq	MP/St
	.01		.10		.01	.001			.02	.001
Tacoma Bridge			MP/Seq		MP/Seq				MP/St	
			.10		.05				.10	
<u>Concepts</u>										
Steam	MP/Seq		MP/Seq	MP/St	MP/Seq	MP/St			MP/Seq	MP/St
	.10		.10	.10	.10	.05			.05	.01
Dome & Volcanic Mts.	St/MP									
	.10									
Amusement Park	Seq/MP									
	.10									
<u>MOTOR SKILLS</u>										
<u>Specific Facts</u>										
Tumbling					MP/Seq	MP/St				
					.01	.10				
Slide Projector	MP/Seq	St/Seq							St/Seq	
	.10	.01							.10	
Shot Put	MP/St		Seq/St		MP/St				MP/Seq	
	.10		.05		.02				.10	
<u>Serial Ordering</u>										
Clay Beads	MP/Seq	MP/St							MP/St	
	.05	.05							.10	
Bird's Nest/Cartwheel	MP/Seq				MP/Seq				MP/Seq	St/Seq
	.05				.02				.01	.01
Motion Picture Proj.			MP/Seq	MP/St	MP/St					
			.10	.05	.01					
<u>Concepts</u>										
Gesture					MP/Seq	MP/St				
					.01	.10				
Trampoline										
Experimental Painting										
<u>SOCIAL STUDIES</u>										
<u>Specific Facts</u>										
Egypt Irrigation	MP/Seq	MP/St	MP/Seq		MP/Seq	MP/St			MP/Seq	MP/St
	.001	.001	.05		.02	.05			.05	.001
African City									St/Seq	
									.05	
Floating Market			MP/St		MP/Seq	MP/St			MP/Seq	MP/St
			.02		.10	.10			.01	.01
<u>Serial Ordering</u>										
Banana Harvesting	MP/Seq	MP/St	MP/Seq	MP/St	MP/Seq	MP/St	Seq/St	MP/Seq	MP/Seq	MP/St
	.001	.001	.01	.01	.001	.001	.10	.10	.10	.02
Copra			MP/Seq	MP/St	MP/St					
			.001	.01	.10					
Lumbering	MP/Seq	MP/St	MP/Seq		MP/St					
	.10	.05	.10		.05					
<u>Concepts</u>										
African Village	MP/Seq				MP/Seq	MP/St			MP/Seq	MP/St
	.05				.05	.02			.05	.01
East. Europe/Midd. Amer.									MP/St	
Transportation in India									.10	

*This should be read: "The Motion Picture mode was superior to the Still mode at < .05 level of significance and the Sequenced mode was superior to the Still mode at < .10 level of significance as compared by t-test."

The mental ability of the subjects did not appear to interact with any of the visual presentation modes, subject matter content areas, or instructional objectives being served to produce differences in test performance. A number of significant differences were observed for one or the other of the mental ability groups; but, where significant differences occurred for both mental ability groups, they were always in the same direction. This consistency of response held for both grade levels.

Neither mental ability group deviated from the pattern of the major analyses of the combined groups or from that of the sex groups, in which the presentation of specific facts in science and concepts in motor skill content appeared to be least influenced by mode of visual presentation.

Conclusions

The analysis of the performance on the total tests for different learner characteristics in each of the 27 stimulus sequences resulted in the following conclusions:

1. There appeared to be no relationship between the sex of the subjects and their performance with any of the visual modes of presentation or subject matter content areas.

2. There was a tendency for the girls to make a more variable response than the boys in the cognitive serial ordering of motor skill content.

3. There appeared to be no relationship between the mental ability of the subjects and their performance with any of the visual modes of presentation, subject matter content areas, or instructional objectives being served.

Analysis of Total Performance For Individual Test Items

The mean test performance scores on each of the items in the 27 tests were compared by means of analysis of variance. Where significant differences were found, comparisons between treatment groups were made by t-test. The results for the significant test items are presented in Table 20 of Appendix D. From the test items showing the greatest difference on performance among the three visual presentation modes, 27 items from nine sequences have been selected for more critical analysis, with the intent of discovering specific characteristics of the visuals as they relate to learning of the content being tested. This analysis will be presented below as grouped by the instructional objective being served.

Knowledge of Specific Facts

The test question resulting in some of the largest differences among the three visual presentation modes occurred in the sequence on "Egypt Irrigation" (Social Studies content). This question consisted of four items asking the subjects to draw a circle around the pictures of the water-raising methods that were illustrated in the stimulus materials (see Appendix B, page 102). This was a question of straightforward visual recognition, three of the four choices being illustrated in the stimuli (Items #1a, #1b, and #1d). Figure 2 illustrates excerpts from the sequenced and still picture treatments pertaining to the test question and presents the analysis of variance and t-test comparisons among the treatment groups. On all four of the test items the motion picture treatment showed a statistically significant superiority over one or both of the still picture treatments at both the fifth and sixth grade levels. There were no consistent results from the two still treatments. On Test Item #1a the still mode resulted in greater (but nonsignificant) learning than the sequenced mode, but on Test Item #1b the sequenced mode resulted in significantly greater learning than the still mode. It is possible that the exposure of only a single slide (but for an equal length of time) for the still mode as compared with eleven slide changes in the sequenced mode contributed to these very significant differences in learning. On Test Item #1d the superiority of the still over the sequenced mode is difficult to explain. The three slides in the still mode are somewhat difficult to read because of the cluttered background, and the oxen are not clearly depicted. No explanation can be given for the motion picture superiority on the one choice not illustrated in the stimulus sequences (Test Item #1c).

For the sequence on "Floating Markets in Thailand" (Social Studies content), a question that asked the subjects to choose the two ways of powering boats in Thailand warrants attention. An excerpt from the sequenced and still picture treatments, together with the statistical analysis, is presented in Figure 3. The responses to Test Item #1b shows that the correct selection of "motor" as one of the means of powering boats significantly favored the motion picture treatment over the two still treatments. The reason for this superiority is again difficult to determine, although it is possible that the motion picture was able to depict the phenomenon of "speed" more realistically than did the still treatments, particularly in that none of the visuals in any of the treatments gave a good picture of the actual motor on the motor-powered boats. On the other hand, on Test Item #1c where the correct selection was "paddle," small differences among the treatments existed, possibly a result of the "paddle" being viewed often in the visuals. No explanation can be offered for the superiority of the motion picture treatment on the correct answering of Test Item #1a ("sail") which was not depicted in the stimuli. It should be noted that the responses for the two still treatments were practically identical.

Stimulus Content:

13



14*



15

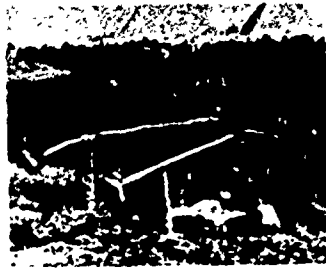

16



17



18*



19



20



21



22



23



24



25*



26*



27



28

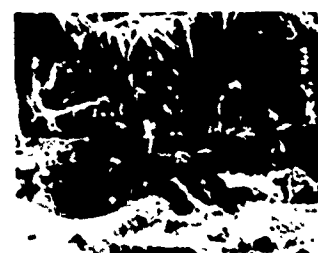

29



30*



Figure 2 - Excerpts from "Egypt Irrigation"
(Social Studies: Specific Facts)

*Frames selected for Still picture mode. Frames without the asterisk comprised the Sequenced Still mode stimulus.

31



32



33



34



35



36



37



38



39



40



41



42



43



44



45*



46



47



48



49



50*

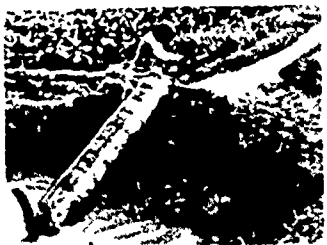

51

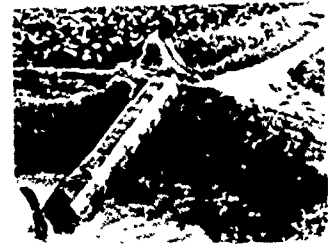
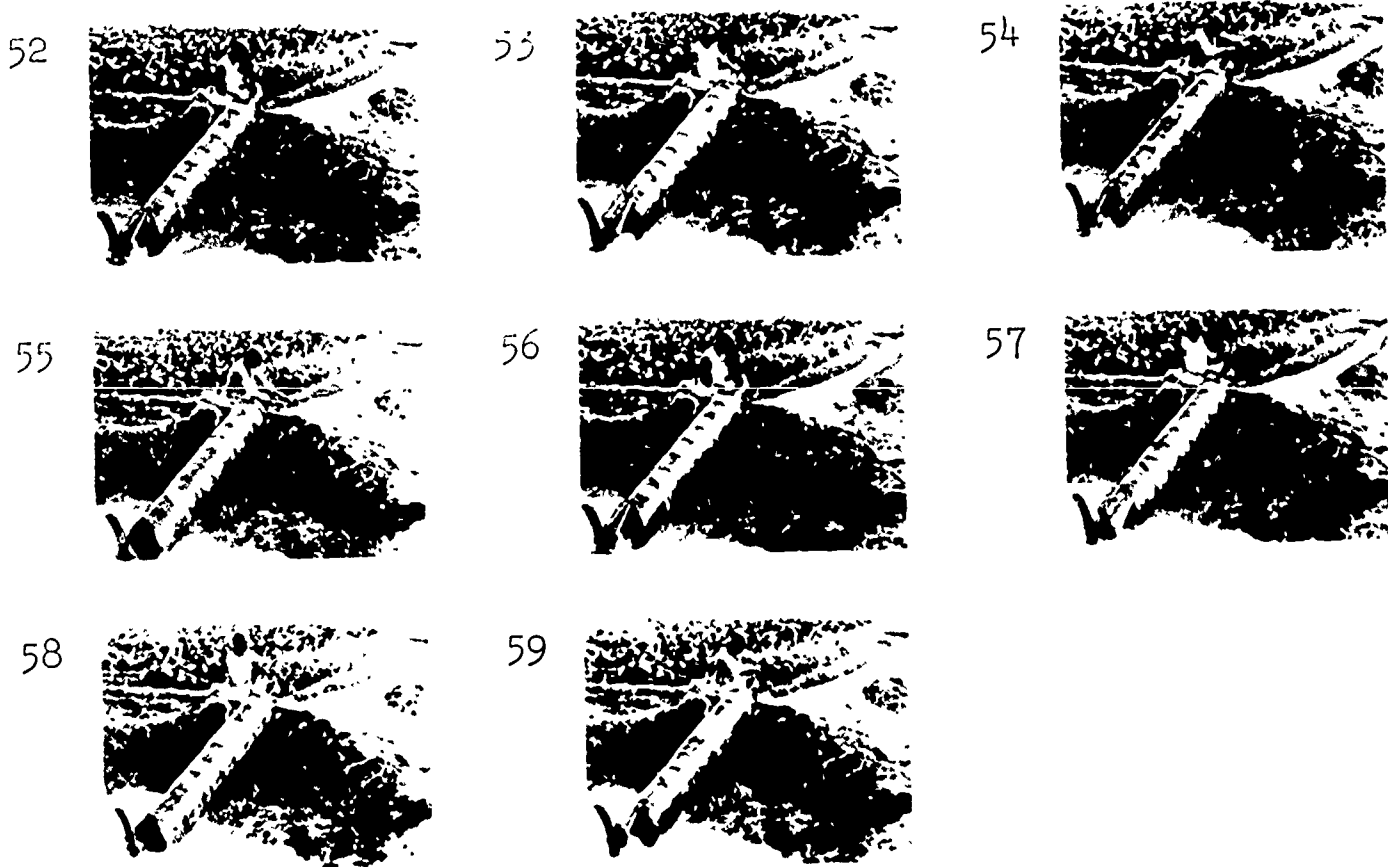

Figure 2--Continued



Test Questions: Subjects were asked to draw a circle around the pictures of water-raising methods that were illustrated in the stimulus materials (see Appendix B, Page 102).

Test Performance Analysis:

Ques.	Mode	Fifth Grade			Sixth Grade		
		Mean	ANOVA	t-test	Mean	ANOVA	t-test
#1a	MP	.85	F=3.060 p < .10	MP/Seq .02**	.94	F=4.344 p < .025	MP/Seq .01 MP/St .05
	Seq	.57			.66		
	St	.74			.75		
#1b	MP	.97	F=7.972 p < .001	MP/St .001 Seq/St .05	.94	F=21.665 p < .001	MP/St .001 Seq/St .001
	Seq	.86			.95		
	St	.61			.47		
#1c	MP	.91	F=7.035 p < .005	MP/Seq .01 MP/St .001	.82	F=3.034 p < .10	MP/St .05 Seq/St .10
	Seq	.61			.79		
	St	.52			.58		
#1d	MP	.91	F=14.999 p < .001	MP/Seq .001 MP/St .05 St/Seq .01	.97	F=10.209 p < .001	MP/Seq .001 MP/St .001
	Seq	.32			.53		
	St	.68			.64		

Figure 2--Continued

**This should be read: "The Motion Picture mode was superior to the Sequenced mode at < .02 level of significance as compared by t-test."

Stimulus Content

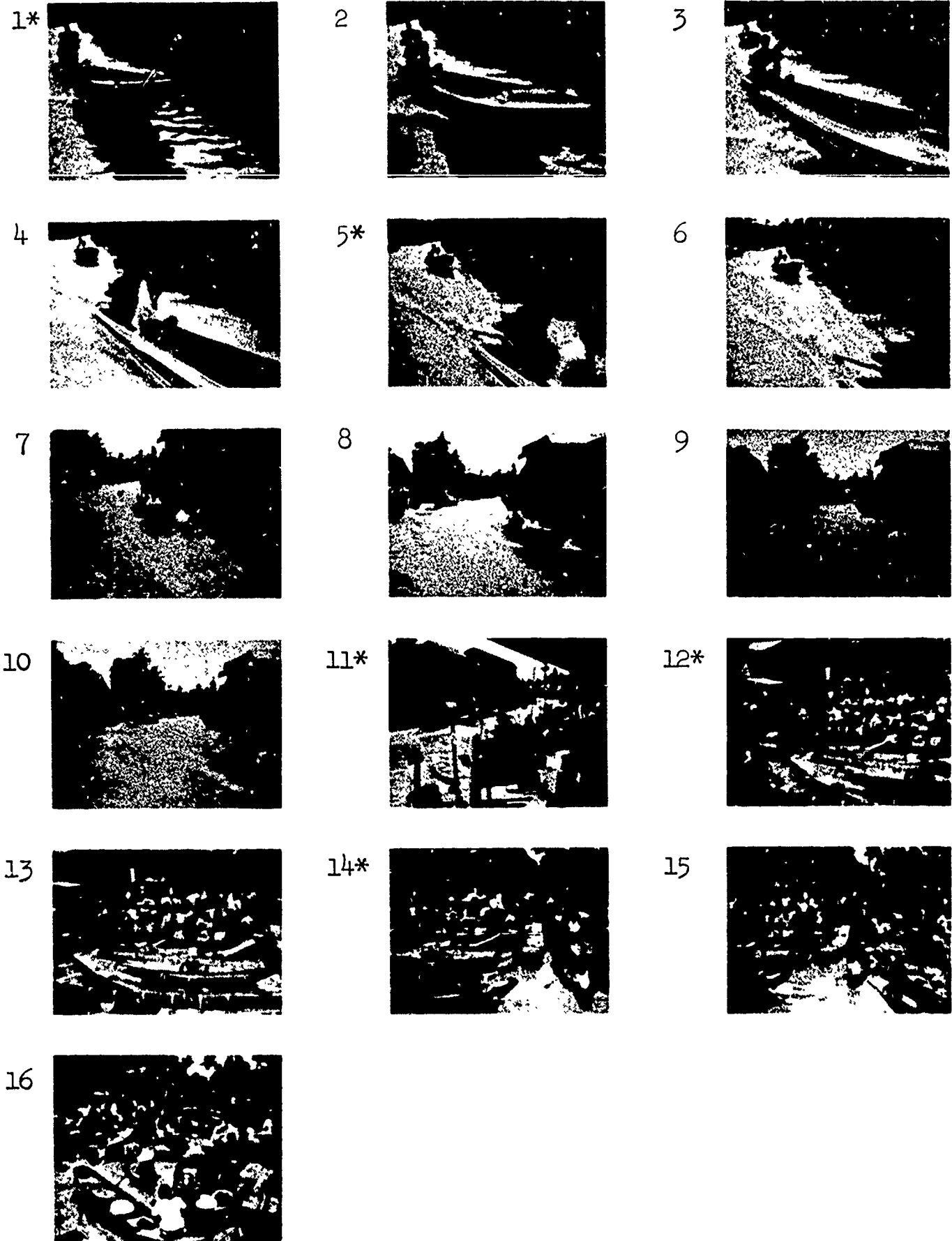

Figure 3 - Excerpt from "Floating Market"
(Social Studies: Specific Facts)

*Frames selected for Still picture mode. Frames without the asterik comprised the Sequenced Still mode stimulus.

Test Question #1:

Pick the two ways of powering boats in Thailand.
 (Draw a circle around the letters next to the right answers.)

- a. sail
- b. motor
- c. paddle
- d. towing

Test Performance Analysis:

Ques.	Mode	Fifth Grade			Sixth Grade		
		Mean	ANOVA	t-test	Mean	ANOVA	t-test
#1a	MP	.81	F=4.753 p < .025	MP/Seq .01** MP/St .05	.86	F=5.436 p < .01	MP/Seq .01 MP/St .02
	Seq	.46			.52		
	St	.54			.61		
#1b	MP	.42	F=2.189 p > .10	MP/Seq .10 MP/St .10	.67	F=11.919 p < .001	MP/Seq .001 MP/St .001
	Seq	.21			.24		
	St	.21			.21		
#1c	MP	1.00	F=3.436 p < .05	MP/Seq .05	.97	F=1.037 p > .10	---
	Seq	.85			.91		
	St	.96			.97		
#1d	MP	.71	F= .013 p > .10	---	.83	F=1.941 p > .10	MP/St .10
	Seq	.73			.70		
	St	.71			.63		

Figure 3--Continued

**This should be read: "The Motion Picture mode was superior to the Sequenced mode at < .01 level of significance as compared by t-test."

The results of the two motor skill sequences on the "Slide Projector" and the "Shot Put" are of particular interest because they are the only two sequences in which one or both of the still picture treatments surpassed the motion picture treatment in effectiveness.

In the "Slide Projector" sequence a constructed response question was asked in which the subject was asked to write in the two steps to be taken and their correct order in switching on the projector. An excerpt of this sequence and the results of the statistical analysis are presented in Figure 4. The still picture treatment was found to be superior to both the motion picture and sequenced treatment for both parts of the question at both grade levels. An examination of the visuals pertaining to this question shows that five slides were projected for the sequenced treatment and two slides for the Still treatment. No ready explanation for these effects can be given, although the consistency of the results indicates that some rather strong influence was operating to make the still presentation more effective. It is possible that the movement in the motion picture treatment and the simulated movement (including the rapid frame changes) in the sequenced (simulated motion) treatment were distracting to the learner, considering a total projection time of only 3.1 seconds for the sequence. On the other hand, the two still picture slides presented the two steps in simple order and gave the viewer a chance to study them. It should be noted that this sequence was the only sequence in the entire experiment that used verbal labels, the "Fan" and "Lamp" being marked. The minimum of movement in the still treatment may have allowed time to direct attention to these two crucial cues.

In the "Shot Put" sequence the sequenced treatment showed significant superiority to the motion picture and still treatments in the fifth grade but not the sixth grade in a question relating to the reasons for swinging a leg around. The entire sequence and statistical results are presented in Figure 5. The reasons for the superiority of the sequenced treatment cannot be determined.

Serial Ordering

Several large test score differences were found on the "Plant Growth" (Science content) sequence, predominantly favoring the motion picture treatment over the still picture treatments. Figure 6 presents an excerpt from this sequence together with the statistical analysis. It may be observed that the four slides in the still treatment rather closely conform to the illustrations in the test question (see Appendix B, Page 85), yet the motion picture was superior. No reasons for this superiority are discerned in the nature of the visual themselves.

For the sequence on "Filtering" (Science), in which the subjects were asked to put the steps in order for making a paper filter, the motion picture treatment was again superior to the still picture treatments. There were no significant differences between the two still

Stimulus Content:

18*



19



20

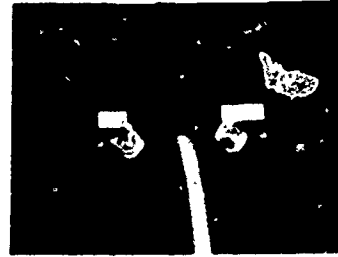

21*



22

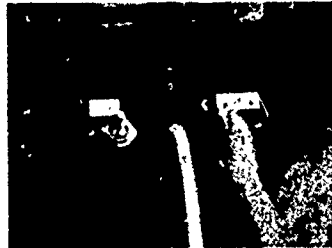

Test Question #3: "The right way to switch on the slide projector is to turn on first the (a) FAN and second the (b) LAMP. (Write right answer in the Space.)

Test Performance Analysis:

Ques.	Mode	Fifth Grade			Sixth Grade		
		Mean	ANOVA	t-test	Mean	ANOVA	t-test
#3a	MP	.42	F=10.100 p < .001	St/MP .01** St/Seq .001	.35	F=5.966 p < .005	St/MP .01 St/Seq .01
	Seq	.25			.39		
	St	.79			.69		
#3b	MP	.65	F= 7.337 p < .005	MP/Seq .05 St/Seq .001	.49	F=2.143 p > .10	St/MP .10 St/Seq .10
	Seq	.36			.50		
	St	.82			.69		

Figure 4 - Excerpt from "Slide Projector" (Motor Skills: Specific Facts)

*Frames selected for Still picture mode. Frames without the asterisk comprised the Sequenced Still mode stimulus.

**This should be read: "The Still mode was superior to the Motion Picture mode at < .01 level of significance as compared by t-test."

Stimulus Content:

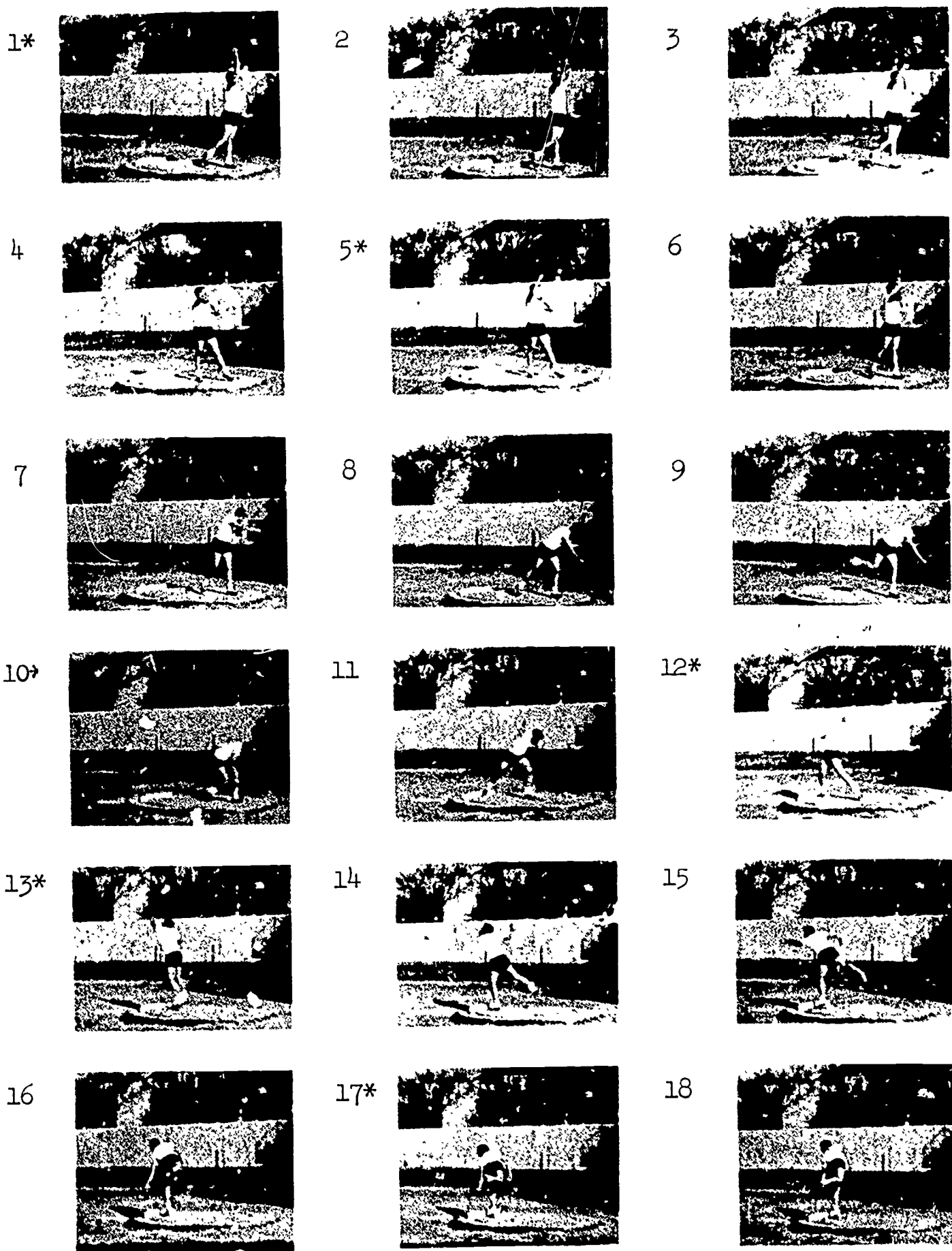

Figure 5 - "Shot Put" (Motor Skills: Specific Facts)

*Frames selected for Still picture mode. Frames without the asterisk comprised the Sequenced Still mode stimulus.

19*



20



21



22*



Test Question #1: "The man swung his right leg around to help him to:

- a. turn
- b. start
- c. move
- d. jump"

Test Performance Analysis:

Ques.	Mode	Fifth Grade			Sixth Grade		
		Mean	ANOVA	t-test	Mean	ANOVA	t-test
#1	MP	.46	F=5.358 p <.01	Seq/MP .01** Seq/St .01	.75	F=1.307 p >.10	---
	Seq	.86			.60		
	St	.58			.73		

Figure 5--Continued

**This should be read: "The Sequenced mode was superior to the Motion Picture mode at < .01 level of significance as compared by t-test."

Stimulus Content:

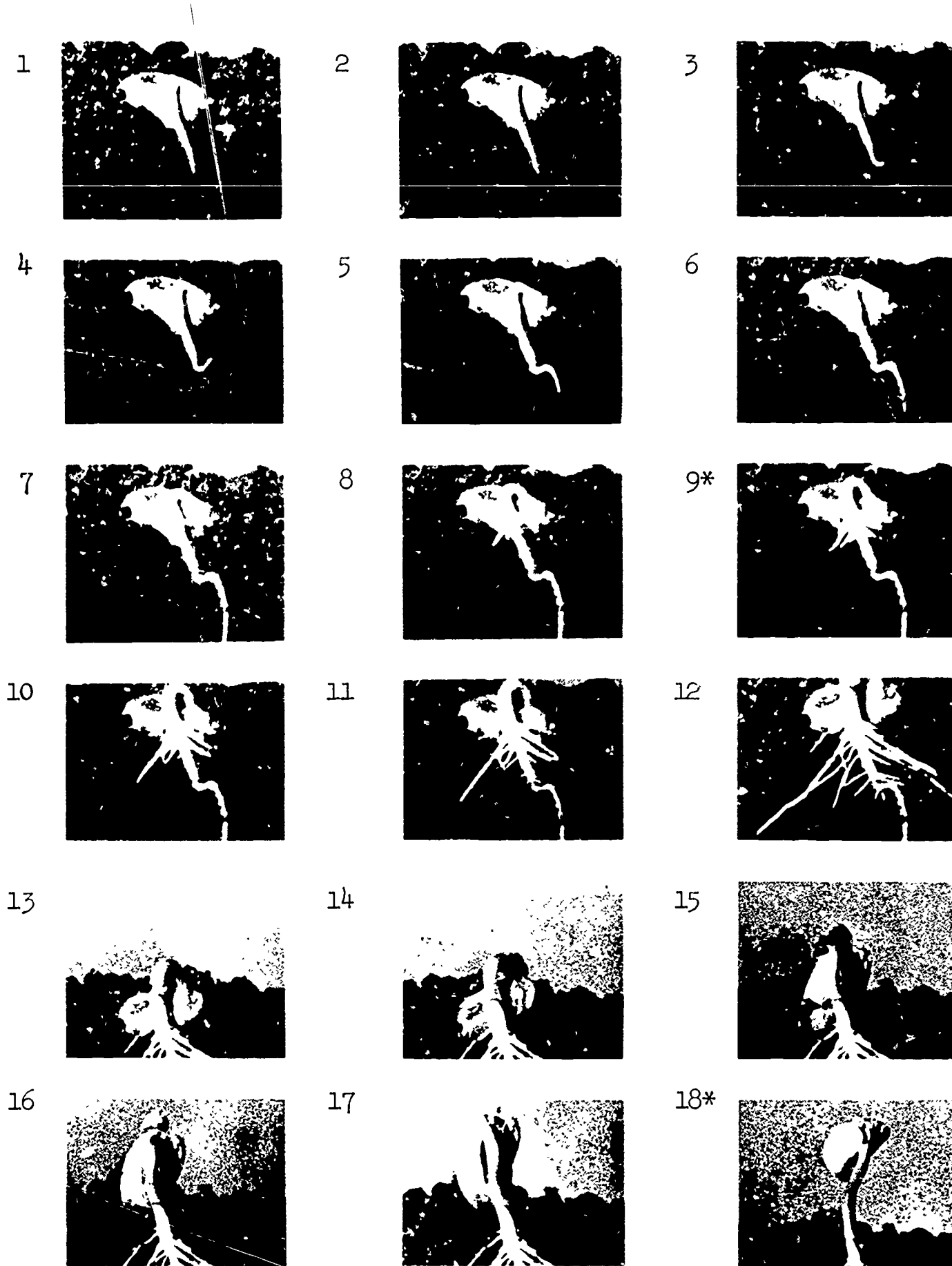

Figure 6 - Excerpt from "Plant Growth" (Science: Serial Ordering)

*Frames selected for Still picture mode. Frames without the asterisk comprised the Sequenced Still mode stimulus.

19



20

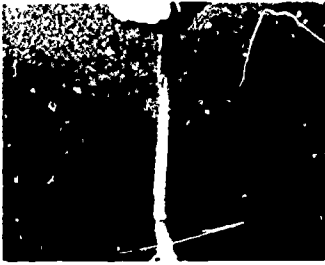

21



22

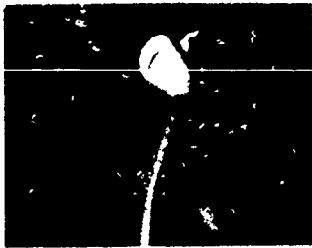

23



24

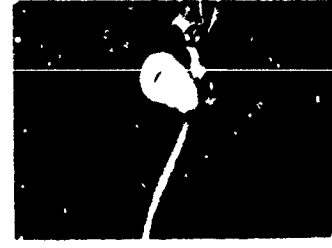

25*

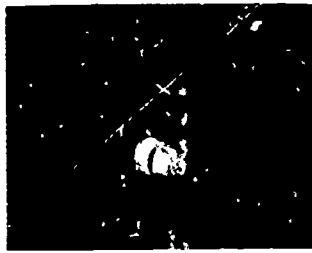

Test Questions: Subjects were asked to put the three steps for growing a bean plant in the right order (see Appendix B, Page 83).

Test Performance Analysis:

Ques.	Mode	Fifth Grade			Sixth Grade			
		Mean	ANOVA	t-test	Mean	ANOVA	t-test	
#1a	MP	.67	F=7.330 p < .005	MP/Seq .01** MP/St .01	.60	F=7.991 p < .001	MP/Seq .05 MP/St .001 Seq/St .10	
	Seq	.23						.36
	St	.25						.17
#1b	MP	.96	F=26.135 p < .001	MP/Seq .01 MP/St .01	.70	F=4.526 p < .025	MP/Seq .10 MP/St .01	
	Seq	.27						.51
	St	.30						.36
#1c	MP	.67	F=3.485 p < .05	MP/Seq .02 MP/St .10	.62	F=3.183 p < .05	MP/St .02	
	Seq	.32						.51
	St	.40						.33
#1d	MP	.70	F=3.114 p < .10	MP/St .02	.51	F= .805 p > .10	---	
	Seq	.50						.39
	St	.35						.39
#1e	MP	.70	F=8.892 p < .001	MP/Seq .001 MP/St .01	.57	F=2.595 p < .10	MP/St .05	
	Seq	.23						.44
	St	.25						.31

Figure 6--Continued

**This should be read: "The Motion Picture mode was superior to the Sequenced mode at < .01 level of significance as compared by t-test."

treatments. The illustration of this sequence and the results are presented in Figure 7. The possible reasons for these differences cannot be determined from a study of the visual presented.

For the sequence on "Banana Harvesting" (Social Studies content) one question asked the subjects to show the right order in which bananas are harvested. The visuals in this sequence and the results are presented in Figure 8. The motion picture treatment produced the highest overall test superiority over the still picture treatments of any question in the study. Here is a case, as with Test Item #1d in the "Egypt Irrigation" sequence, where the cluttered nature of the background made the still picture presentations extremely difficult to read. It may be that, where there is little differentiation between figure and ground (that is, where the activity to be observed blends into the background), the still picture representation does not give an adequate change in viewpoint to permit a separation of the two. In the motion picture version, the plastic bag used to cover the bananas before they were cut from the tree reflected the light, and the continuous motion faithfully reproduced this effect. In the still versions, this reflectance was not noticeable.

Concepts

In the learning of concepts, the sequence on "Steam" (Science content) produced highly significant superiority of the Motion Picture treatment over the still treatments on a question that asked the subjects to describe the work done by steam. The three excerpts from the sequence relating to this question are illustrated and the results presented in Figure 9. It would appear that the particular concept being presented here (the "pushing" of the steam) is that of action and reaction in which the perception of the directionality of the two forces is important to learning. Seemingly, the Motion Picture mode was best able to depict this phenomenon.

The sequence from the "African Village" (Social Studies content), in which subjects were tested as to the place where villagers obtained their water (the "ground"), showed an extremely high superiority for the motion picture over the two still treatments and some superiority of the sequenced over the still treatments. The appropriate excerpt from this sequence and the statistical results are given in Figure 10. The reason for the motion picture advantage cannot be determined. However, the still mode showed only one slide of actual extraction of water from the ground, and even this picture might not have been interpreted correctly.

Stimulus Content:

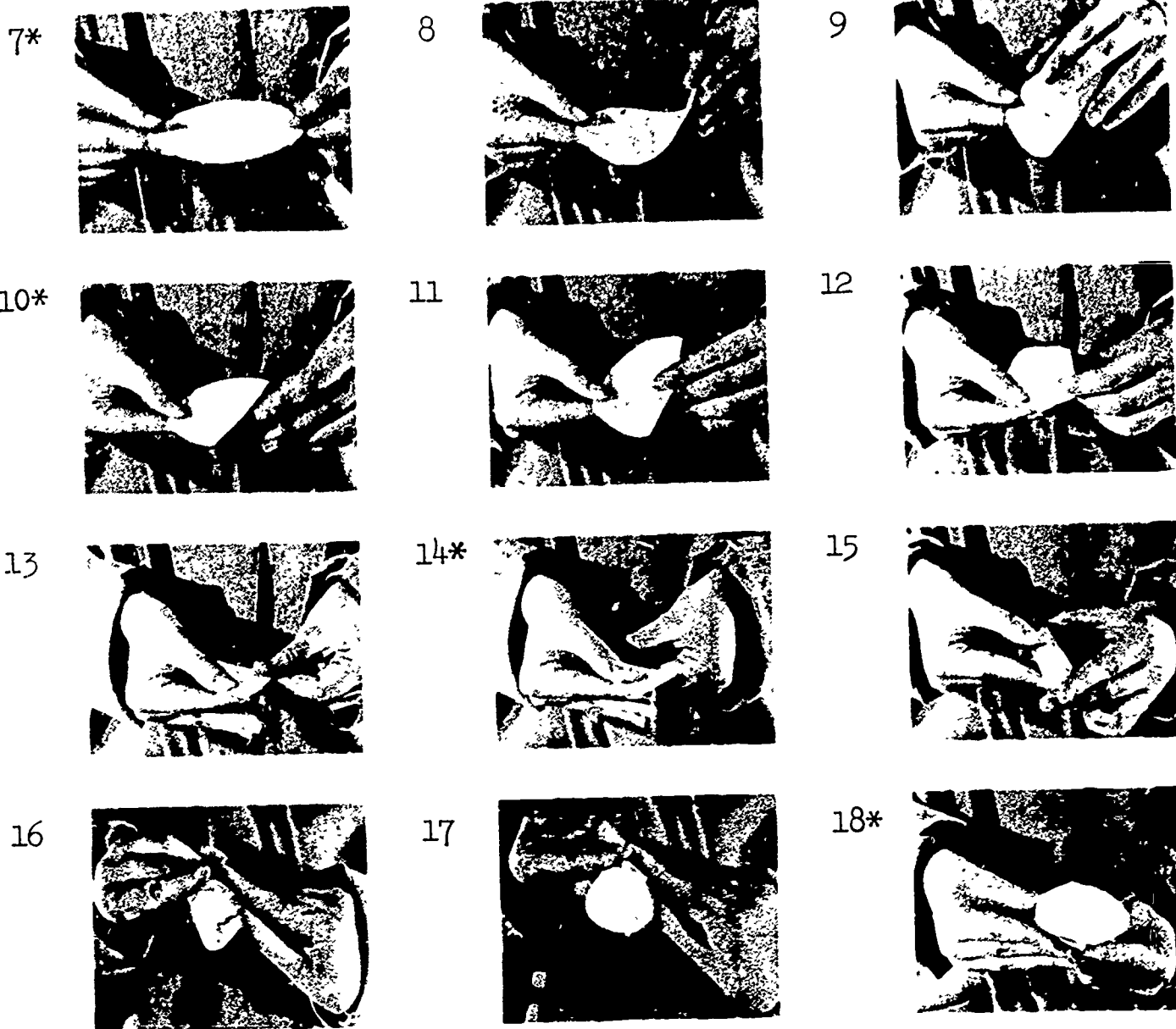

Test Questions: Subjects were asked how to make a paper filter for a funnel, putting the steps in order (see Appendix B, Page 85).

Figure 7 - Excerpt from "Filtering" (Science: Serial Ordering)

*Frames selected for Still picture mode. Frames without the asterisk comprised the Sequenced Still mode stimulus.

Test Performance Analysis:

Ques.	Mode	Fifth Grade			Sixth Grade		
		Mean	ANOVA	t-test	Mean	ANOVA	t-test
#2a	MP	.77	F=1.113 p >.10	---	.80	F=1.070 p >.10	---
	Seq	.75			.75		
	St	.59			.65		
#2b	MP	.73	F=1.144 p >.10	---	.87	F=4.184 p <.025	MP/Seq .02** MP/St .02
	Seq	.50			.61		
	St	.63			.62		
#2c	MP	.50	F= .230 p >.10	---	.77	F=6.805 p <.005	MP/St .001
	Seq	.60			.64		
	St	.52			.38		
#2d	MP	.55	F=1.600 p >.10	MP/St .10	.77	F=5.093 p <.01	MP/Seq .01 MP/St .01
	Seq	.45			.47		
	St	.30			.46		
#2e	MP	.77	F=1.890 p >.10	MP/St .10	.80	F=2.632 p <.10	MP/Seq .05 MP/St .10
	Seq	.70			.56		
	St	.52			.62		
#2f	MP	.55	F=1.519 p >.10	---	.70	F=7.496 p <.001	MP/Seq .05 MP/St .001
	Seq	.55			.50		
	St	.33			.32		

Figure 7--Continued

**This should be read: "The Motion Picture mode was superior to the Sequenced mode at < .02 level of significance as compared by t-test."

Stimulus Content:

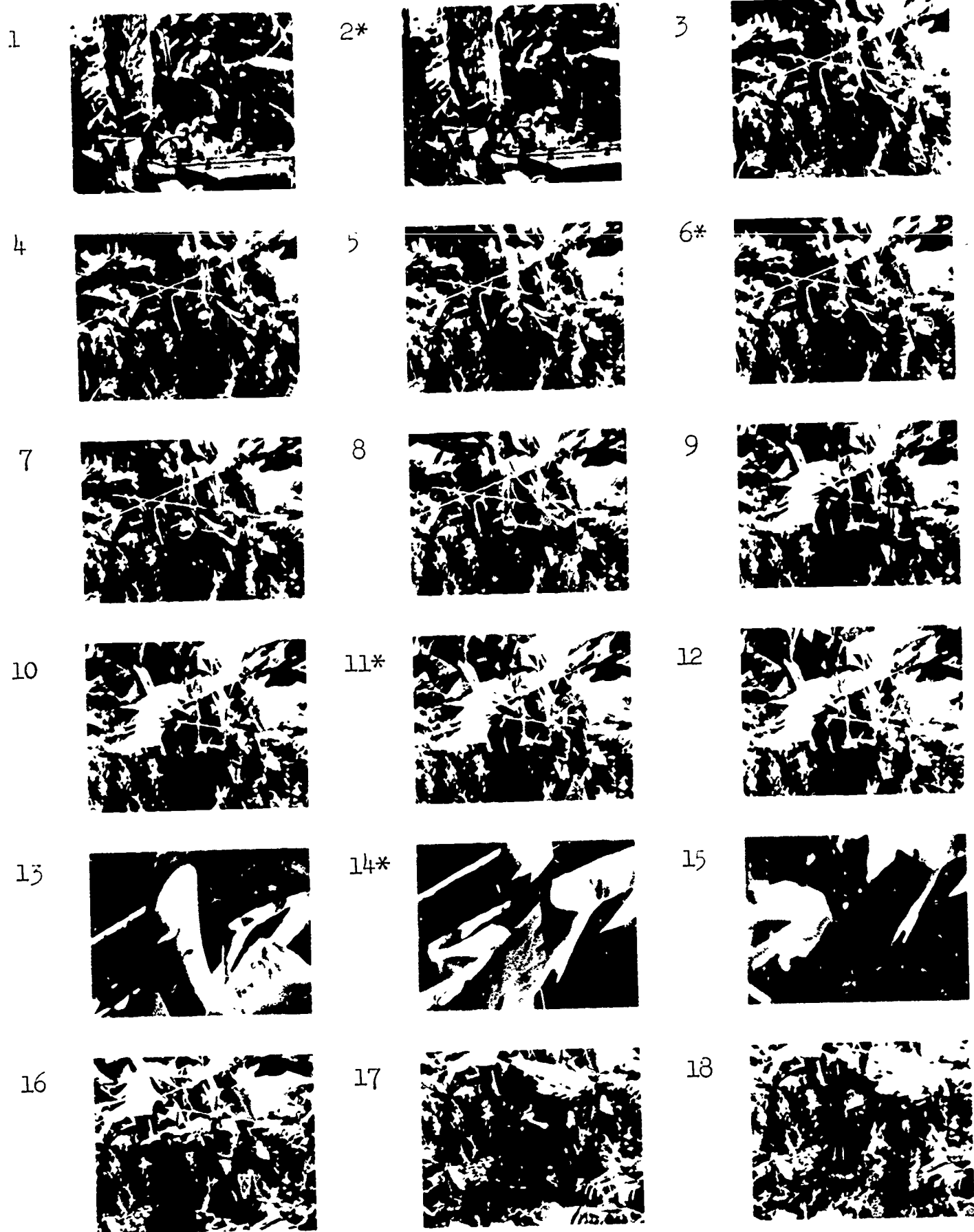
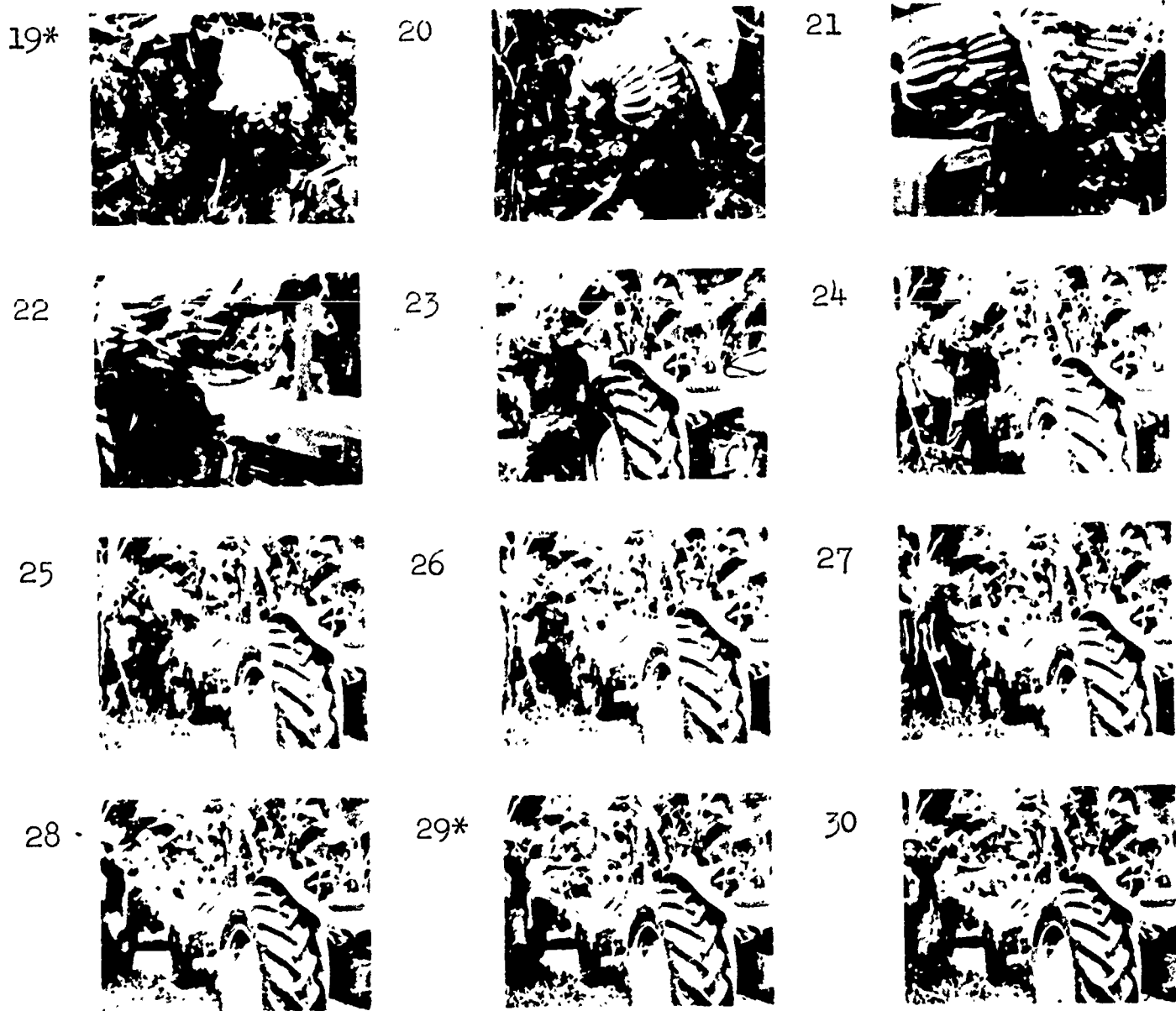

Figure 8 - Excerpt from "Banana Harvesting"
(Social Studies: Serial Ordering)

*Frames selected for Still picture mode. Frames without the asterisk comprised the Sequenced Still mode stimulus.



Test Question #1:

Show the right order in which bananas are harvested.
(Put the numbers 1, 2, and 3 in the right spaces):

- a. 2 cut off bananas
- b. 1 cover bananas with plastic bag
- c. 3 cover with burlap material

Figure 8--Continued

31



32



33



34*

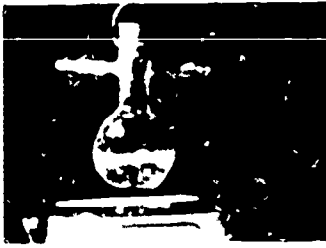

36



37



38*



39



40



41



42



43*

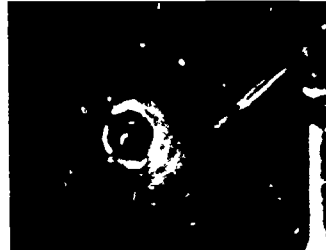

Test Question #1: "Choose a word that describes work done by steam."

- a. pulling
- b. rising
- c. heating
- d. pushing

Test Performance Analysis:

Ques.	Mode	Fifth Grade			Sixth Grade		
		Mean	ANOVA	t-test	Mean	ANOVA	t-test
#1	MP	.85	F=14.705 p < .001	MP/Seq .001** MP/St .001	.87	F=17.056 p < .001	MP/Seq .001 MP/St .001
	Seq	.32					
	St	.25					

Figure 9--Continued

**This should be read: "The Motor Picture mode was superior to the Sequenced mode at < .001 level of significance as compared by t-test."

Stimulus Content:

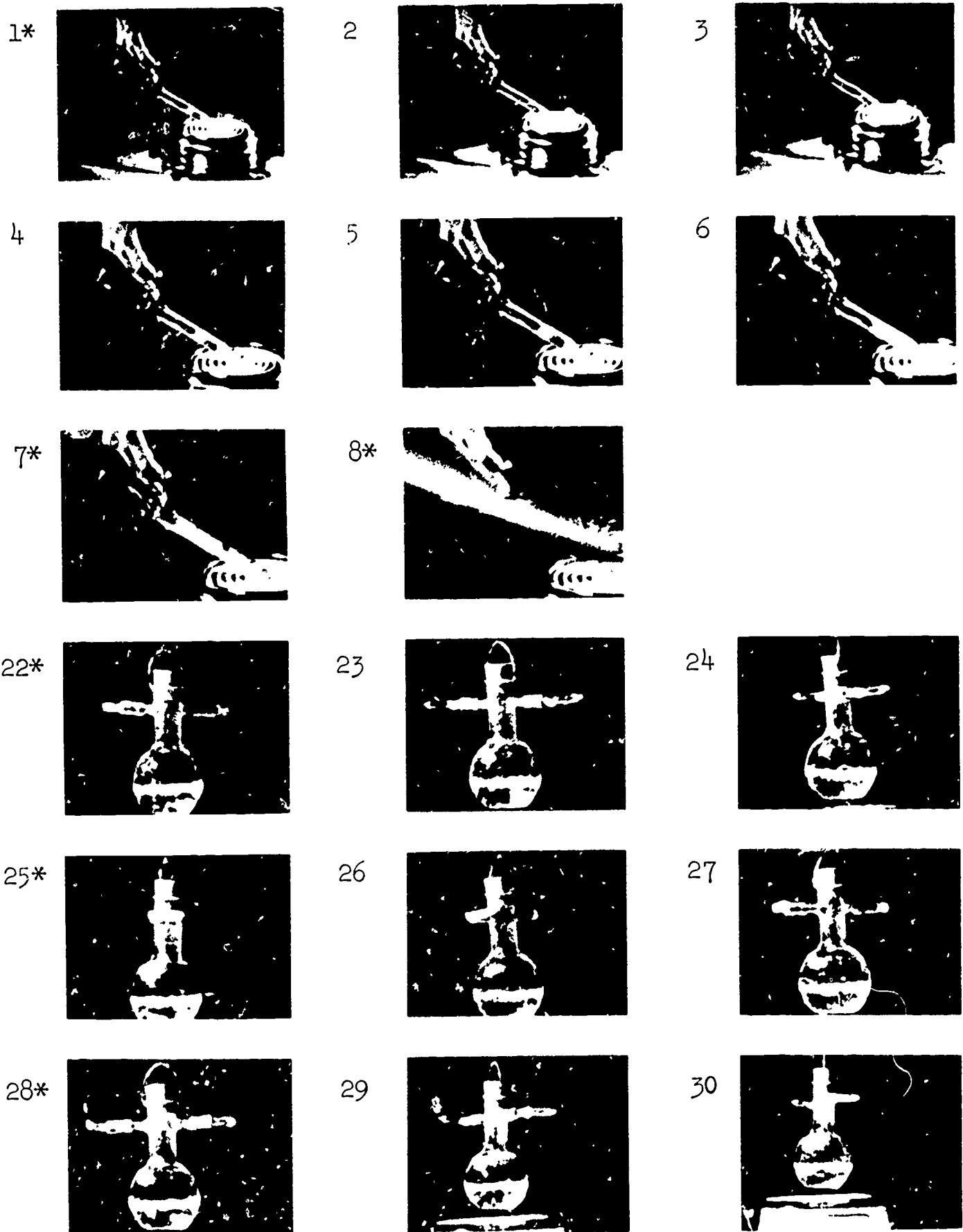
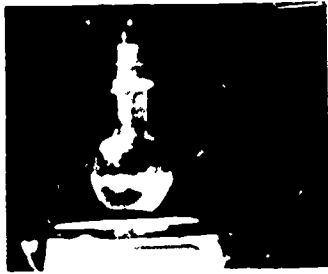

Figure 9 - Three Excerpts from "Steam" (Science: Concepts)

*Frames selected for the Still picture mode. Frames without the asterisk comprised the Sequenced Still mode stimulus.

31



32

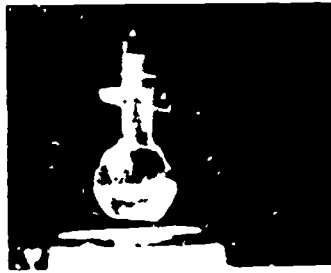

33



34*



36

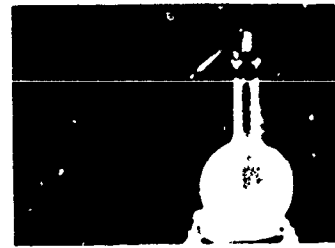

37

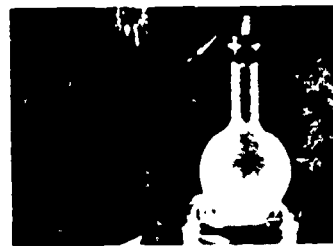

38*



39



40



41



42



43*

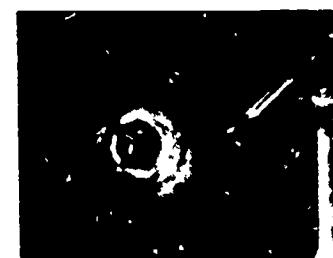

Test Question #1: "Choose a word that describes work done by steam."

- a. pulling
- b. rising
- c. heating
- d. pushing

Test Performance Analysis:

Ques.	Mode	Fifth Grade			Sixth Grade			
		Mean	ANOVA	t-test	Mean	ANOVA	t-test	
#1	MP	.85	F=14.705 p < .001	MP/Seq .001** MP/St. .001	.87	F=17.056 p < .001	MP/Seq .001 MP/St .001	
	Seq	.32						.36
	St	.25						.33

Figure 9--Continued

**This should be read: "The Motor Picture mode was superior to the Sequenced mode at < .001 level of significance as compared by t-test."

Stimulus Content:

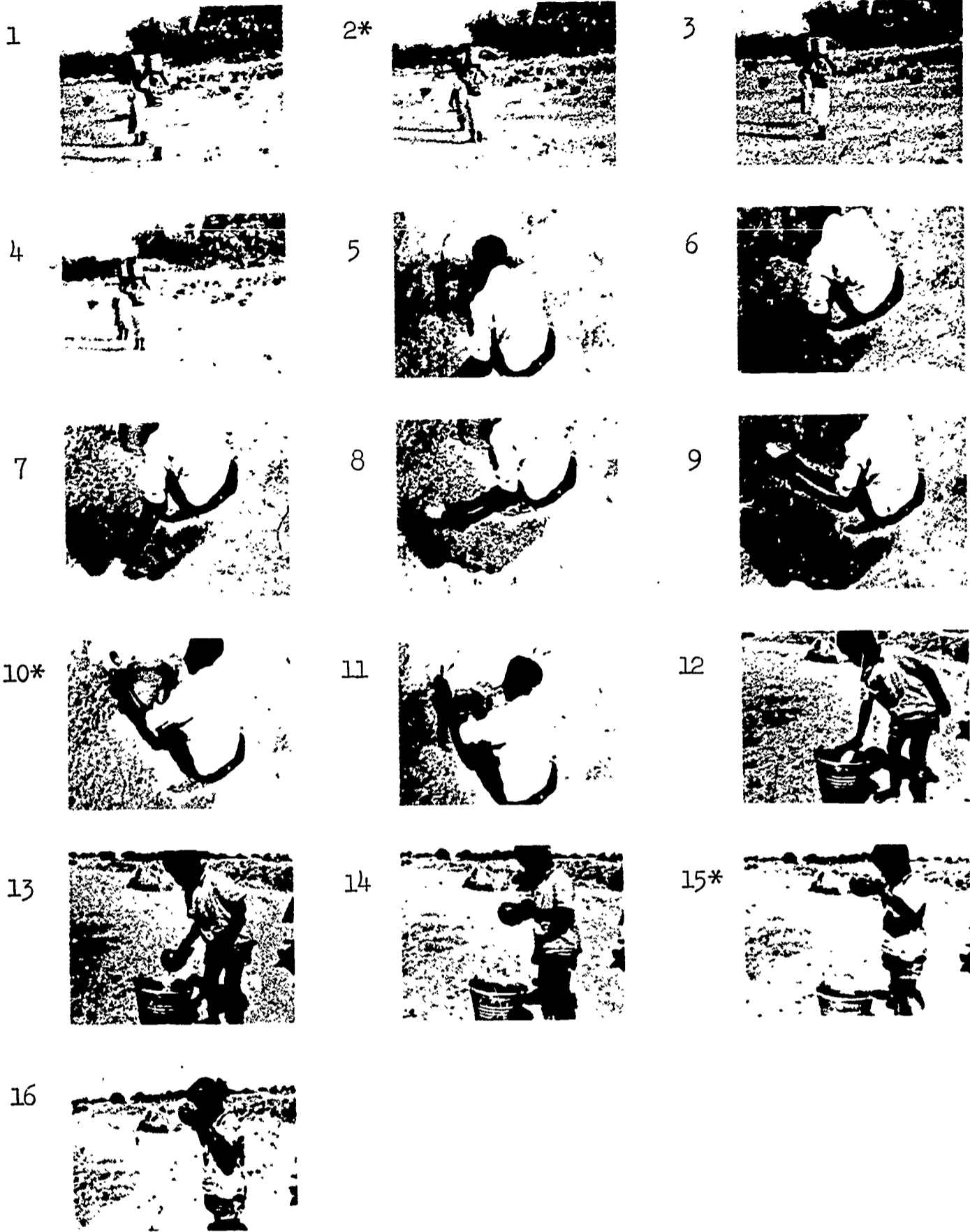

Figure 10 - Excerpt from "African Village"
(Social Studies: Concepts)

*Frames selected for Still picture mode. Frames without the asterisk comprised the Sequenced Still mode stimulus.

Test Question #4:

In the picture you saw people getting water from the:

- a. water tank
- b. ground
- c. river
- d. water faucet

Test Performance Analysis:

Ques.	Mode	Fifth Grade			Sixth Grade		
		Mean	ANOVA	t-test	Mean	ANOVA	t-test
#4	MP	.88	F=33.549 p < .001	MP/Seq .001** MP/St .001	.97	F=48.803 p < .001	MP/Seq .001 MP/St .001 Seq/St .01
	Seq	.25					
	St	.16					

Figure 10--Continued

**This should be read: "The Motion Picture mode was superior to the Sequenced mode at < .001 level of significance as compared by t-test."

Analysis of "Contours"

As reported in the review of the literature (page 6), Hovland, Lumsdaine and Sheffield (1949) found that a motion picture film was significantly more effective in teaching the elevation of terrain onto a map in the form of contour lines than was a still filmstrip. Because this finding is one of the few reported in the literature in which specific comparisons were made between motion picture and still picture modes and because the present study also used a sequence on "contour lines," it is worth studying the results. Table 20 in Appendix D (on page 116) gives the comparative scores and significance of the differences for the three treatments on the test items where significant differences occurred. It will be noted that the results were contradictory, some favoring one treatment and some the others. It is clear, however, that the motion picture treatment did not demonstrate the same superiority that it showed on other stimulus sequences. It would appear that the Hovland, Lumsdaine and Sheffield conclusions are not supported by this study.

Conclusions

The analysis of performance on specific test items for each of the stimulus sequences resulted in several tentative conclusions:

1. The motion picture mode of visual presentation was predominantly superior to the sequenced and still picture modes at both grade levels.

2. In general, it is not possible to determine the precise reasons for this superiority. However, where such phenomena as speed, directionality, action and reaction, changing viewpoint, and progressive changes are necessary for an understanding of the content, the motion picture mode appeared to be highly favored.

Attitude Toward the Stimulus Presentations

The results of the analyses of variance comparing the attitudes of the subjects in the different treatment groups are presented in Tables 9 and 10. Although the responses predominantly favored the motion picture treatment over the two still treatments, as might be expected, there were no discernible patterns related to either the subject matter content of the material or the instructional objectives being served.

In a further analysis of the attitude data, correlations were made between attitude toward the stimulus and total performance test scores, presented in Table 11. Of the 162 correlations made for both grade levels, only 16 were significant at less than the .05 level.

TABLE 9
RESULTS OF ANALYSIS OF ATTITUDE TOWARD THE VISUAL PRESENTATIONS
BY TREATMENT GROUP (FIFTH GRADE)

	Analysis of Var.			t-test Comparisons
	df	F	Prob.	
SCIENCE				
<u>Specific Facts</u>				
Nuclear Reactions	2/47	2.352	--	
Cells	2/48	3.619	<.05	Seq/MP.01;Seq/St.05*
Contours	2/41	1.290	--	
<u>Serial Ordering</u>				
Plants	2/30	2.452	--	
Filtering	2/52	11.209	<.001	MP/St.001;MP/Seq.10;Seq/St.05
Tacoma Bridge	2/14	.720	--	
<u>Concepts</u>				
Steam	2/46	5.439	<.01	MP/Seq.01;St/Seq.10
Dome & Volcanic Mts.	2/39	3.058	<.10	Seq/St.02
Amusement Park	2/23	9.446	<.001	MP/Seq.01;St/Seq.02
MOTOR SKILLS				
<u>Specific Facts</u>				
Tumbling	2/61	.050	--	
Slide Projector	2/70	1.569	--	
Shot Put	2/63	3.145	<.10	MP/Seq.05;St/Seq.05
<u>Serial Ordering</u>				
Clay Beads	2/45	.036	--	
Bird's Nest/Cartwheel	2/53	1.813	--	
Motion Picture Proj.	2/57	8.336	<.001	MP/Seq.01;St/Seq.01
<u>Concepts</u>				
Gesture	2/62	1.112	--	
Trampoline	2/49	1.962	--	
Experimental Painting	2/52	2.165	--	
SOCIAL STUDIES				
<u>Specific Facts</u>				
Egypt Irrigation	2/79	4.394	<.025	MP/St.01;MP/Seq.02
African City	2/67	.522	--	
Floating Market	2/68	2.108	--	
<u>Serial Ordering</u>				
Banana Harvesting	2/52	1.367	--	
Copra	2/66	7.499	<.005	MP/Seq.001;St/Seq.05
Lumbering	2/64	4.814	<.025	MP/Seq.01;MP/St.05
<u>Concepts</u>				
African Village	2/69	1.030	--	
East.Europe/Midd.Amer.	2/61	.386	--	
Transpor. in India	2/65	.543	--	

*This should be read: "The Sequenced treatment was superior to the Motion Picture treatment at the .01 level and the Still treatment at the .05 level of significance as compared by t-test."

TABLE 10
RESULTS OF ANALYSIS OF ATTITUDE TOWARD THE VISUAL PRESENTATIONS
BY TREATMENT GROUP (SIXTH GRADE)

	Analysis of Var.			t-test Comparisons
	df	F	Prob.	
<u>SCIENCE</u>				
<u>Specific Facts</u>				
Nuclear Reactions	2/91	.527	--	
Cells	2/71	13.685	<.001	MP/St.001;MP/Seq.10;Seq/St.01*
Contours	2/84	4.539	<.025	MP/Seq.01;St/Seq.10
<u>Serial Ordering</u>				
Plants	2/63	1.457	--	
Filtering	2/88	8.715	<.001	MP/St.001;Seq/St.02
Tacoma Bridge	2/40	3.380	<.05	St/MP.02;Seq/MP.10
<u>Concepts</u>				
Steam	2/95	2.389	<.10	MP/St.05;MP/Seq.10
Dome & Volcanic Mts.	2/75	5.541	<.01	Seq/St.01;Seq/MP.10
Amusement Park	2/57	.962	--	
<u>MOTOR SKILLS</u>				
<u>Specific Facts</u>				
Tumbling	2/91	.600	--	
Slide Projector	2/92	7.205	<.005	MP/Seq.01;MP/St.01
Shot Put	2/86	2.991	<.10	MP/St.05
<u>Serial Ordering</u>				
Clay Beads	2/84	17.735	<.001	MP/Seq.001;St/Seq.001
Bird's Nest/Cartwheel	2/79	.083	--	
Motion Picture Proj.	2/75	3.495	<.05	MP/Seq.05;St/Seq.10
<u>Concepts</u>				
Gesture	2/87	.961	--	
Trampoline	2/82	1.188	--	
Experimental Painting	2/74	.732	--	
<u>SOCIAL STUDIES</u>				
<u>Specific Facts</u>				
Egypt Irrigation	2/95	2.644	<.10	MP/Seq.10
African City	2/89	17.155	<.001	MP/Seq.001;St/Seq.001
Floating Market	2/82	9.064	<.001	St/Seq.001;MP/Seq.10;St/MP.10
<u>Serial Ordering</u>				
Banana Harvesting	2/82	6.306	<.005	MP/St.01;MP/Seq.02
Copra	2/78	8.168	<.001	MP/Seq.01;MP/St.01
Lumbering	2/80	7.849	<.001	MP/Seq.001;MP/St.02
<u>Concepts</u>				
African Village	2/86	1.613	--	
East.Europe/Midd.Amer.	2/83	4.785	<.025	MP/Seq.01;MP/St.10
Transpor. in India	2/84	5.190	<.01	MP/Seq.01;St/Seq.05

*This should be read: "The Motion Picture treatment was superior to the Still treatment at the .001 level and the Sequenced treatment at the .10 level of significance, and the Sequenced treatment was superior to the Still treatment at the .01 level of significance as compared by t-test."

TABLE 11

CORRELATION COEFFICIENTS BETWEEN ATTITUDE TOWARD STIMULUS
AND PERFORMANCE TEST SCORES

	Fifth Grade			Sixth Grade		
	Motion Picture	Sequence	Still	Motion Picture	Sequence	Still
<u>SCIENCE</u>	(N=26)	(N=20)	(N=18)	(N=37)	(N=38)	(N=37)
<u>Specific Facts</u>						
Nuclear Reactions	.299	.280	-.421	-.026	-.114	-.130
Cells	.115	.017	-.145	-.197	-.326*	-.100
Contours	-.271	-.092	.251	-.124	.019	.076
<u>Serial Ordering</u>						
Plants	.237	-.063	-.089	.135	.011	-.120
Filtering	.188	.184	-.193	-.167	-.119	-.074
Tacoma Bridge	.394*	.003	.042	-.053	-.041	.170
<u>Concepts</u>						
Steam	-.167	-.068	-.040	.121	.043	-.107
Dome & Volcanic Mts	-.182	-.044	-.020	.121	.382*	-.139
Amusement Park	-.498*	.212	.422	-.248	.036	.126
<u>MOTOR SKILLS</u>	(N=29)	(N=30)	(N=28)	(N=41)	(N=37)	(N=36)
<u>Specific Facts</u>						
Tumbling	-.095	-.083	-.047	-.215	-.030	.141
Slide Projector	.231	.156	-.345	-.046	.408*	-.032
Shot Put	.258	.279	.131	.098	-.056	-.239
<u>Serial Ordering</u>						
Clay Beads	-.014	.159	-.104	-.148	.074	-.116
Bird's Nest/Cart.	.249	-.367*	.460*	.397**	.061	.328*
Motion Picture Proj	-.025	.099	.145	.108	-.011	.245
<u>Concepts</u>						
Gesture	.253	.259	.117	-.260	.047	.094
Trampoline	-.114	-.021	-.229	-.111	.117	.032
Experimental Paint.	.081	-.066	.461*	-.269	.164	-.141
<u>SOCIAL STUDIES</u>	(N=33)	(N=28)	(N=29)	(N=33)	(N=38)	(N=35)
<u>Specific Facts</u>						
Egypt Irrigation	.037	-.030	.183	-.021	-.015	.300
African City	-.227	.163	.098	-.054	.046	.034
Floating Market	-.153	-.241	-.332	.159	.063	-.122
<u>Serial Ordering</u>						
Banana Harvesting	.483**	-.018	-.142	.276	.271	.356*
Copra	.181	-.095	.177	.250	.115	.125
Lumbering	-.162	-.161	-.154	-.419*	-.004	-.081
<u>Concepts</u>						
African Village	.199	-.198	.120	.072	.374*	-.033
East. Eur/Mid. Amer	-.244	-.060	-.329	-.210	-.067	.342*
Transp. in India	.268	-.451*	.177	.104	-.022	.122

*p < .05

**p < .01

These were equally divided among the three treatment modes, but, where a significant correlation occurred for the still mode (5 cases) it was always positive.

It may be concluded from these results that attitude toward the stimulus presentation was not a factor in learning the content.

CHAPTER IV

CONCLUSIONS AND DISCUSSION

This chapter will present the specific conclusions that may be derived from the data and discuss the results of the study and its implications.

Conclusions

The following conclusions may be drawn from an analysis of the results of the study:

1. The motion picture mode of visual presentation was superior to the sequenced and still picture modes on 70% of the stimulus sequences for the fifth grade and 74% for the sixth grade.
2. In general, it is not possible to determine the precise reasons for this superiority. However, where such phenomena as speed, directionality, action and reaction, changing viewpoint, and progressive changes are necessary for an understanding of the content, the motion picture mode appears to be favored over the still modes of visual presentation.
3. The superiority of the motion picture mode prevailed regardless of subject matter content, the instructional objective being served, the interaction between content and objectives, the grade level of the subjects, or the sex of the subjects.
4. It appeared that concept learning, regardless of the subject matter content, was less subject to influence by the mode of visual presentation than either the learning of specific facts or of serial ordering.
5. The serial ordering of the content seemed to be most susceptible to influence by the motion picture mode of visual presentation.
6. The mode of visual presentation seemed to have the least influence upon performance in presenting specific facts in science and concepts in motor skill content.
7. There appeared to be no practical differences in the effectiveness of the two still picture modes of visual presentation.

62/63

8. There appeared to be no relationship between the sex of the subjects and their performance with any of the visual modes of presentation or subject matter content areas.

9. There appeared to be no relationship between the mental ability of the subjects and their performance with any of the visual modes of presentation, subject matter content areas, or instructional objectives being served.

10. There was a tendency for the girls to make a more variable response than the boys in the cognitive serial ordering of motor skill content.

11. It appears that subjective attitude toward the mode of stimulus presentation is not a factor in learning the content.

Discussion

The overall superiority of the motion picture mode of visual presentation over the still picture modes makes it difficult to predict the precise conditions under which different types of visual presentation would be most effective or to develop a taxonomy of motion. The overriding conclusion that can be drawn from the study is that the motion picture mode is more effective no matter what the content of the material, the instructional objectives being served, or the characteristics of the learners. There are some aspects of the study and its results that deserve further discussion, however, and it will be the purpose of this section to consider them.

The Motion Variable

What are the factors that might contribute to the effectiveness of the motion picture?

As noted earlier, Vetter (1959) felt that motion heightened realism, clarified spatial relationships, depicted action and interaction, and altered the velocity of observation so as to give meaning to that which transpires too slowly or rapidly. Hovland, Lumsdaine and Sheffield (1949) suggested that the motion picture permitted the progressive alteration of the angle from which an object was viewed. On the other hand, Pryluck and Snow (1967) speculated that movement facilitated for the viewer the process of "cognitive transformation," in the sense that Guilford (1967) used it, or the changing of location, arrangement of parts, or the sensory qualities or quantities of the object viewed. Inherent to some degree in these three statements is the assumption that some sort of progressive change was taking place and that this changing condition was increasing the learning of the content presented.

The Factor of "Change." If "change," by itself, is a factor in increasing learning (or, perhaps, increasing the attention the viewer pays to the stimulus), the motion picture film should prove to be the superior mode of visual presentation under practically every stimulus situation. In general, this was the case in the present study. Even in those instances where the content tested indicated no apparent reason for the motion picture's supremacy (that is, all the cues necessary for correctly answering the question were contained in one or both of the still picture treatments), more often than not the motion picture group performed at a higher level. In 82% of the 73 test items that showed significant differences at $< .10$ level for the fifth grade, the motion picture group made the highest score. At the sixth grade level the motion picture group scored highest in 80% of the 89 significant test items.

If one were to accept the hypothesis that the mere "changing" nature of the motion picture stimuli was the critical element in its superiority, one would also have to predict that the sequenced still treatment (that simulated motion and incorporated many visual changes, but of a more static nature) would be superior to the single still picture. However, such did not prove to be the case in this study. There were no practical or significant differences between the two modes in influencing performance.

Does this contradiction signify that we must discard our hypothesis as to the importance of "change" as a factor in learning from visual presentations? Not necessarily. But we may need to be more precise as to what kind of "change" we are dealing with. The motion picture film may be distinguished from the sequenced still picture by its depiction of progressive or continuous minute changes in the visual image rather than large-step disjointed (but related) changes. The artificial and unrealistic form of the projected sequenced visuals may have introduced a distracting element into the presentation that had a negative effect upon learning. Instead of serving as a transitional presentation mode between the motion and still pictures (as assumed in this study), it may have possessed unnatural characteristics that introduced an uncontrolled variable. This explanation cannot be supported with data, however, and is a question needing further investigation.

As a matter of fact, the whole question of the "change" factor in visual presentation needs further study. Certainly, this is one characteristic that differentiates the motion picture film from the still picture. But just what the precise dimensions of these differences are have yet to be determined, and they were beyond the scope of the present study.

Other Motion Factors. Several observations were made above in the analysis of individual test items relating to conditions where the motion picture demonstrated outstanding superiority and where possible

reasons for this could be identified. Three of these conditions--determination of "displacement" or "direction," the factor of "speed," and the nature of the figure-ground relationships--deserve closer attention.

The perception of the "direction" one or more objects may take or the "displacement" that occurs as a function of some kind of action or reaction might be enhanced by depiction in motion. The results of one question in the "Steam" sequence (Figure 9) presented rather strong evidence that some factor was operating in the motion picture treatment that was not operating in the two still picture treatments. Comparing the motion picture with the sequenced visual, it may be noted that the one distinguishing feature was the actual direction of the movement of the steam: away from the jets on the bottle. This was readily apparent in the motion picture treatment as we could see the movement of the steam. In the sequenced and still treatments, however, the steam was observed in a static state, and it was not possible to perceive the displacement of the space by the steam. In other words, the positional relationships of the steam to the bottle jets were determinable in the motion picture but not in the stills. On the other hand, the progressive positions of the bottles and jets themselves were readily observed in all treatments. It is interesting to note that no significant differences occurred on Test Item #5, which tested learning of the direction the bottle turned. But this latter observation of the reaction alone (without a clear depiction of the action that caused it) may have been an inadequate stimulus to convey the notion that a "pushing" action was taking place. Analysis of this single test item certainly does not constitute proof of the presence of the "displacement" or "directionality" factor, but it suggests a possible reason for the results. In an earlier study Allen, Filep and Cooney (1967) called this particular phenomenon "action-process" and attempted to test it under different stimulus conditions in programmed instruction (motion picture, still pictorial, and verbal print) without success. However, their failure to find an advantage for the motion picture treatment may have been due to the nature of the criterion test, as discussed in their report, and the question is still open. The rationale for the recognition of such a factor as described here is strong enough and the evidence is supporting enough to warrant a more intensive study of this particular variable.

The factor of the determination of the "speed" of an object or the transfer of the perception of speed to the drawing of some conclusion about the object may also have some relationship to the motion variable. The particular example from the study pertained to the analysis of the "Floating Market" sequence (Figure 3). The test item required the selection of "motor" as one method of powering boats in Thailand. Motor boats were shown several times in the sequence, and it might have been expected that no differences in recognizing them should occur among the three treatments. On the contrary, the motion picture group performed at a significantly higher level than the two still picture groups, only about 20% of the still group subjects answering the question correctly. The fact that none of the visuals in

any of the treatments gave clear pictures of the actual motor on the boats would lead to the conclusion that the subjects depended upon other visual cues in making their responses. The principal cues that were available to them were the speed of the motor boat as contrasted with that of the paddle boats and the wake or water disturbance caused by the motor boat as it went through the canal. Only the motion picture treatment was able to depict accurately the speed of the motor boat, and this faster speed may have been associated with the fact that motor boats go faster than other boats, thus leading to a correct response. One might also explain these differences as being a function of the perception of the "displacement" of the water and the air by the boat or the action of the wake or small waves caused by the boat. The factor of "speed" might, therefore, be related to the factor of "displacement" or "directionality" discussed above. In any event, this phenomenon warrants further research as an element related to the motion variable.

The nature of the ground against which the figure appears and the figure-ground relationships may affect the learning of the content differently under various visual presentation modes. Two sequences possessed characteristics that may illustrate these differences. In the sequence showing the harvesting of bananas in the "Banana Harvesting" (Figure 8) extremely high differences were obtained favoring the motion picture treatment, particularly in relation to the covering of the bananas with a plastic bag before cutting them from the tree. The correct answering of this question required the recognition of the plastic bag. However, the plastic bag became a part of the ground and could not be discriminated as being a figure in the still picture versions. On the other hand, the motion picture version showed the flashes of light from the plastic bag as it was moved over the bunches of bananas, thus presenting the cues necessary for answering the question. The second sequence in which the cluttered background tended to merge with the figures on it was the water wheel and oxen sequence in "Egypt Irrigation" (Figure 2). Here, again, it is difficult to separate the oxen, gear arrangement, and water wheel from the foliage in the background in the two still versions, whereas the motion picture shows this rather clearly. It would appear that, where the figure or object to be discriminated has physical characteristics similar to the background against which it is viewed (such as color, shape, size, position, texture, etc.), the motion picture mode of visual presentation will more adequately display the stimulus for discrimination. Again, the phenomenon that might be operating here, as in the cases cited earlier, is that of "displacement," or the movement of a figure or object against a relatively stable background. This movement then caused the object to be separated from the background and thus perceived as an entity distinct from it.

It may be seen that all of these examples are related and need to be carefully studied under conditions that would permit a clear and unequivocal identification of their characteristics and effects. It was beyond the scope of this exploratory study to do more than identify some of the possible factors contributing to the effectiveness of the

different visual presentation modes. It is certainly obvious that the motion picture showed such consistent superiority over the still pictures that some powerful inherent mode-related influences must be operating.

The Question of Technical Quality

It was noted earlier that, in copying the frames from the motion pictures to produce the two still picture treatments, there was a loss in technical quality. The question is immediately raised as to the effects of these quality differences upon the performance under each of the visual presentation conditions. In other words, could the inferiority of the two still picture treatments to the motion picture treatment be a function of the quality of the visual images projected rather than to other inherent characteristic differences among the visual modes themselves?

A careful examination of the results of the study and of the actual visuals used leads to the conclusion that the technical quality of the visuals was probably not a factor in the differences obtained. When one studies the still visuals in relation to the test questions, it can be seen that the cues needed to answer the questions are as clearly readable in the still versions as in the motion picture version. The two exceptions are the water wheel sequence from "Egypt Irrigation" (Figure 2) and the "Banana Harvesting" sequence (Figure 8). The results from these two sequences have already been discussed and some hypotheses made relative to the differences found. However, these conclusions could be modified if technical quality were really an operating variable. On the other hand, the differences noted could be explained as well by the figure-ground explanation made as by the technical quality explanation.

Implications

The study has demonstrated the overall effectiveness of presentation in the motion picture form. This implies that, under most conditions, the motion picture will be at least as effective as the still picture in presenting material to be learned cognitively. The exact conditions under which the motion picture should be used are still not clear. It would appear that motion is certainly indicated where the particular content to be learned consists of the movement itself and its characteristics or is enhanced and differentiated by the cues provided in the action of the movement. If the motion might distract the viewer from careful attending to the content, as might be the case in extremely short sequences or where action (movement) is occurring that is unrelated to the specific material to be learned, the still picture may prove to be a better choice. This study was unable to obtain definitive answers to the question of what pictorial mode to use under specified conditions, but it did point out some specific conditions that should be studied in greater detail.

REFERENCES

1. Allen, William H. "Audio-Visual Communication." 3rd ed. of Encyclopedia of Educational Research, edited by C. W. Harris. New York: Macmillan, 1960. Pp. 115-137.
2. Allen, William H. "Media Stimulus and Types of Learning." AV Instruction, XII (January 1967), 27-31.
3. Allen, William H., and Daehling, William A. An Exploratory Study of Form Perception as Applied to the Production of Educational Media. NDEA Title VII Project No. S-1454. Los Angeles: Research Division, Department of Cinema, University of Southern California, June 30, 1968.
4. Allen, William H.; Cooney, Stuart M.; and Weintraub, Royd. Audio Implementation of Still and Motion Pictures. NDEA Title VII Project No. 5-0741. Los Angeles: Research Division, Department of Cinema, University of Southern California, April 16, 1968.
5. Allen, William H.; Filep, Robert F.; and Cooney, Stuart M. Visual and Audio Presentation in Machine Programed Instruction. United States Office of Education Cooperative Research Program Project No. 5-0724-2-12-1. Los Angeles: Research Division, Department of Cinema, University of Southern California, January 1967.
6. Arnheim, Rudolf. Art and Visual Perception. Berkeley: University of California Press, 1954.
7. Bloom, Benjamin S. (Ed.) Taxonomy of Educational Objectives: The Classification of Educational Goals: Handbook I: Cognitive Domain. New York: Longmans, Green and Co., 1956.
8. Briggs, Leslie J., and Others. Instructional Media: A Procedure for the Design of Multi-Media Instruction, A Critical Review of Research, and Suggestions for Future Research. Pittsburgh, Penn.: American Institutes for Research, 1967.
9. Brown, James W.; Lewis, Richard B.; and Harcleroad, Fred F. A-V Instruction: Materials and Methods. New York: McGraw-Hill, 1959.
10. Computer Sciences Laboratory, University of Southern California. SoComp: A Series of Automatic Statistical Programs. Los Angeles: University of Southern California, January 1967.

11. Dale, Edgar. Audio-Visual Methods in Teaching. Revised Edition. New York: The Dryden Press, 1954.
12. Educational Testing Service. School and College Ability Tests. Princeton, N.J.: Cooperative Test Division, Educational Testing Service, 1957.
13. Educational Testing Service. Sequential Tests of Educational Progress. Princeton, N.J.: Cooperative Test Division, Educational Testing Service, 1963.
14. Eisenstein, Sergei. The Film Sense. New York: Harcourt, Brace and Co., 1942.
15. Eisenstein, Sergei. Film Form. New York: Harcourt, Brace and Co., 1949.
16. Gagné, Robert M. "Human Functions in Systems." In Robert M. Gagné (Ed.), Psychological Principles in System Development. New York: Holt, Rinehart and Winston, 1963. Pp. 35-74.
17. Gagné, Robert M. The Conditions of Learning. New York: Holt, Rinehart and Winston, 1965.
18. Gagné, Robert M., and Bolles, Robert C. "A Review of Factors in Learning Efficiency." In Eugene Galanter (Ed.), Automatic Teaching: The State of the Art. New York: John Wiley and Sons, 1959. Pp. 13-53.
19. Gagné, Robert M., and Gropper, George L. Studies in Filmed Instruction. 1. Individual Differences in Learning from Visual and Verbal Presentations. 2. The Use of Visual Example in Review. Pittsburgh, Penn.: American Institutes for Research, 1965.
20. Gibson, James J. "A Theory of Pictorial Perception." AV Communication Review, II (Winter 1954), 3-23.
21. Gropper, George L. "Learning from Visuals: Some Behavioral Considerations." AV Communication Review, XIV (Spring 1966), 37-69.
22. Guilford, J. P. The Nature of Human Intelligence. New York: McGraw-Hill, 1967.
23. Hoban, Charles F., and van Ormer, Edward B. Instructional Film Research, 1918-1950. Pennsylvania State Instructional Film Research Program, Technical Report No. SDC 269-7-19. Port Washington, N.Y.: U.S. Naval Training Devices Center, Office of Naval Research, 1950.

24. Hovland, Carl I.; Lumsdaine, Arthur A.; and Sheffield, Fred D. Experiments on Mass Communication. Princeton, N.J.: Princeton University Press, 1949.
25. Kelley, Truman L., and Others. Stanford Achievement Test. New York: Harcourt, Brace and World, 1964.
26. Lorge-Thorndike Intelligence Tests. New York: Houghton Mifflin, 1964.
27. Lumsdaine, A. A. "Instruments and Media of Instruction." In N. L. Gage (Ed.), Handbook of Research on Teaching. Chicago: Rand McNally, 1963. Pp. 583-682.
28. McClusky, H. Y. "An Analytical Study of the Content of Educational Motion Picture Films." In Frank N. Freeman (Ed.), Visual Education. Chicago: University of Chicago Press, 1924. Pp. 377-388.
29. Michotte, A. La Perception de la Causalité. Louvain: Publications Universitaires de Louvain, 1946.
30. Miller, R. B. A Suggested Guide to Functional Characteristics of Training and Training Equipment. Technical Memorandum ML-TM-56-14. Lackland Air Force Base, Texas: Air Force Personnel and Training Research Center, 1956.
31. O'Connor, Virgil J. "An Examination of Instructional Films for Characteristics of an Effective Teaching Presentation." Harvard Educational Review, XX (Fall 1950), 271-284.
32. Parker, James F., Jr., and Downs, Judith E. Selection of Training Media. ASD Technical Report 61-473. Wright-Patterson Air Force Base, Ohio: Behavioral Sciences Laboratory, Aerospace Medical Laboratory, Aeronautical Systems Division, Air Force Systems Command, U.S. Air Force, September 1961.
33. Pryluck, Calvin and Snow, Richard E. "Toward a Psycholinguistics of Cinema." AV Communication Review, XV (Spring 1967), 54-75.
34. Roshal, Sol M. "Film-Mediated Learning with Varying Representation of the Task: Viewing Angle, Portrayal of Demonstration, Motion, and Student Participation." In A. A. Lumsdaine (Ed.), Student Response in Programmed Instruction: A Symposium. Publ. 943. Washington, D.C.: National Academy of Sciences-National Research Council, 1961. Pp. 155-175.
35. Silverman, R. E. The Comparative Effectiveness of Animated and Static Transparencies. Technical Report No. NAVTRADEVCEM 78-1, Instructional Film Research Program, Pennsylvania State University. Port Washington, N.Y.: U.S. Naval Training Devices Center, Office of Naval Research, April 1958.

36. Smith, O. W., and Resnick, L. Impressions of Movement from Static Line Drawings of Human Figures. Ithaca, N.Y.: Cornell University, 1953. Unpublished.
37. Spottiswoode, Raymond. A Grammar of the Film. Berkeley: University of California Press, 1950.
38. Vernon, M. D. A Further Study of Visual Perception. Cambridge: Cambridge University Press, 1952.
39. Vetter, Richard H. A Study of the Significance of Motion in Educational Film Communication. Los Angeles: University of California, 1959. Unpublished doctoral dissertation.

APPENDIX A

STIMULUS MATERIALS

I. Science:

A. Knowledge of Specific Facts:

1. "Chain Reaction - Controlled Chain Reaction" (Produced by Encyclopedia Britannica Films)

Motion Picture: 1 minute 36 seconds
Sequenced: 72 frames
Still: 12 frames

2. "Cell Division" (Produced by Encyclopedia Britannica Films)

Motion Picture: 1 minute 42 seconds
Sequenced 36 frames
Still: 11 frames

3. "Contours" (Produced by Gateway Films)

Motion Picture: 23 seconds
Sequenced: 61 frames
Still: 9 frames

B. Serial Ordering:

4. "Bean Germination" (Produced by Walt Disney Nature Library)

"Plant Self-Feeding" (Produced by International Communications Foundation)

Motion Picture: 1 minute 52 seconds
Sequenced: 81 frames
Still: 11 frames

5. "Filtering" (Produced by Encyclopedia Britannica Films)

Motion Picture: 1 minute 30 seconds
Sequenced: 50 frames
Still: 14 frames

6. "Tacoma Narrows Bridge Collapse" (Produced by Ealing Films)

Motion Picture: 1 minute 31 seconds
Sequenced: 52 frames
Still: 11 frames

C. Concepts:

7. "Heat Can Do Work" Produced by International Communications Foundation)

Motion Picture: 58 seconds
Sequenced: 57 frames
Still: 11 frames

8. "Dome and Volcanic Mountains" (Produced by Film Associates)

Motion Picture: 43 seconds
Sequenced: 53 frames
Still: 9 frames

9. "Amusement Park" (Produced by Science Research Associates)

Motion Picture: 3 minutes 23 seconds
Sequenced: 106 frames
Still: 15 frames

II. Motor Skills:

A. Knowledge of Specific Facts:

1. "Head Balance-Tumbling" and "Hand Balance-Tumbling"
(Produced by Cahill)

Motion Picture: 25 seconds
Sequenced: 64 frames
Still: 13 frames

2. "Slide Projector" (Produced by Chandler)

Motion Picture: 54 seconds
Sequenced: 58 frames
Still: 11 frames

3. "Shot Put" (Produced by Athletic Institute)

Motion Picture: 13 seconds
Sequenced: 22 frames
Still: 8 frames

B. Serial Ordering:

4. "Clay Beads" (Produced by Scope)

Motion Picture: 2 minutes 19 seconds
Sequenced: 98 frames
Still: 14 frames

5. "Bird's Nest" and "Cartwheel" (Produced by Cahill)

Motion Picture: 30 seconds
Sequenced: 56 frames
Still: 11 frames

6. "Motion Picture Projection" (Produced by Chandler)

Motion Picture: 52 seconds
Sequenced: 53 frames
Still: 9 frames

C. Concepts:

7. "Gesture" (Produced by Scope)

Motion Picture: 1 minute 31 seconds
Sequenced: 68 frames
Still: 14 frames

8. "Basic Bounces - Trampolining"
(Produced by Athletic Institute)

Motion Picture: 22 seconds
Sequenced: 91 frames
Still: 22 frames

9. "Experimental Fainting" (Produced by Hester and Associates)

Motion Picture: 40 seconds
Sequenced: 20 frames
Still: 4 frames

III. Social Studies:

A. Knowledge of Specific Facts:

1. "Egypt - Village Irrigation" (Produced by Gateway Films)

Motion Picture: 1 minute 33 seconds
Sequenced: 89 frames
Still: 13 seconds

2. "Africa - City Life" (Produced by Gateway Films)

Motion Picture: 1 minute 59 seconds
Sequenced: 66 frames
Still: 23 frames

3. "Floating Markets of Thailand" (Produced by International Communications Foundation)

Motion Picture: 1 minute 38 seconds
Sequenced: 47 frames
Still: 12 frames

B. Serial Ordering:

4. "New Banana Harvesting Methods" (Produced by International Communications Foundation)

Motion Picture: 2 minutes 30 seconds
Sequenced: 69 frames
Still: 14 frames

5. "Copra Production" (Produced by International Communications Foundation)

Motion Picture: 1 minute 57 seconds
Sequenced: 52 frames
Still: 13 frames

6. "Teak Lumbering in Thailand" and "Lumber Mill" (Produced by International Communications Foundation)

Motion Picture: 2 minutes 53 seconds
Sequenced: 126 frames
Still: 22 frames

C. Concepts:

7. "Africa - Village Life" (Produced by Gateway Films)

Motion Picture: 2 minutes 55 seconds
Sequenced: 90 frames
Still: 17 frames

8. "The Use of Labor in Eastern Europe" and "The Use of Labor in Middle America" (Produced by International Communications Foundation)

Motion Picture: 3 minutes 3 seconds
Sequenced: 107 frames
Still: 28 frames

9. "Transportation in Developing Nations - India"
(Produced by International Communications Foundation)

Motion Picture: 1 minute 36 seconds
Sequenced: 41 frames
Still: 13 frames

APPENDIX B

PERFORMANCE TESTS

EXPLANATION: The correct answers are indicated in the Performance Tests by underlining in the case of the multiple-choice items, by the insertion of the acceptable answers for the constructed responses, or by other self-evident markings. For purposes of clarity, the subject matter content area, instructional objective being tested, and title of the stimulus material are given. These were not presented to the subjects in the actual tests. The letters identifying response points were not shown unless mentioned in the question.

SCIENCE CONTENT

"Nuclear Reactions" (Specific Facts)

1. The drawing of the atom below has different parts marked with numbers. Read each of the descriptions and put the right number in each blank space.

- a. 1 particle about to split atom
- b. 3 an atom about to be divided by a particle
- c. 5 particle that gives light when hit
- d. 2 path of a rotating particle
- e. 4 particle which moves in circular paths

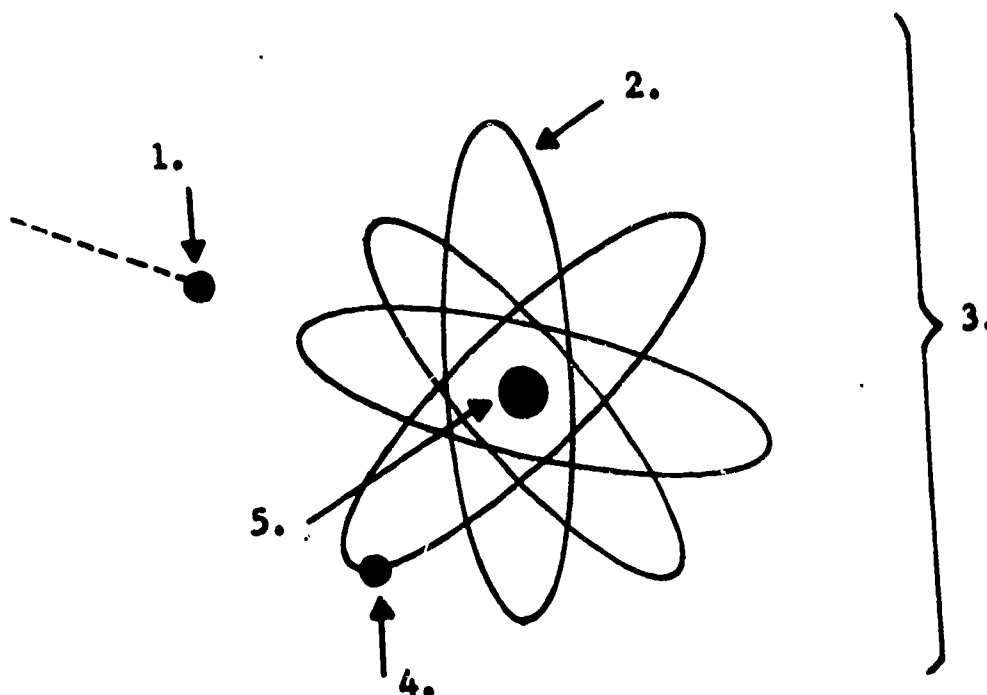

78/79

2. The picture showed atoms being hit. Each time a particle hits other atoms, the particles
 - a. increase in number.
 - b. stop moving.
 - c. bounce away from the atom.
 - d. start moving in a circular path.

3. We can best control change in a nuclear reaction by
 - a. taking away the nuclear material during the reaction.
 - b. changing the number of black bars in the nuclear material.
 - c. turning the black bars in the nuclear material.
 - d. not changing the position of the black bars.

"Cells" (Specific Facts)

1. When the cell divides the "strings"
 - a. go to different cells.
 - b. go toward the center.
 - c. get mixed together.
 - d. go half to one cell and half to the other.

2. In forming new cells, the parent cell gives the new cells
 - a. several pairs of "strings."
 - b. equal amounts of "strings" and cell material
 - c. material in proportion to the number of times split.
 - d. equal amounts of jelly-like cell material.

3. The "strings" in the middle of the cell form into
 - a. a large mass with no observable order of the "strings."
 - b. separate cells containing no "strings."
 - c. "strings" of two.
 - d. circular "strings."

4. The cell is not changing when
 - a. it is multiplying.
 - b. it is growing.
 - c. it is dividing.
 - d. its division has been completed.

5. The drawings below show the cell at different times. Read each of the descriptions and put the right number in each blank space.

- a. 4 beginning of cell division
- b. 3 least movement inside the cell
- c. 1 inner portion of cell disappears
- d. 2 grouping of "strings" into twisted pairs

1.

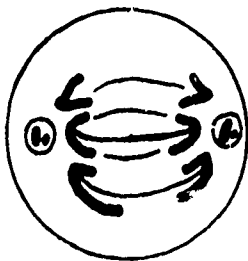

2.

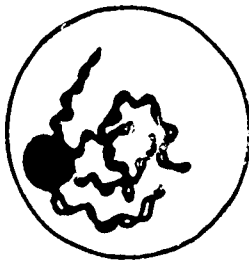

3.

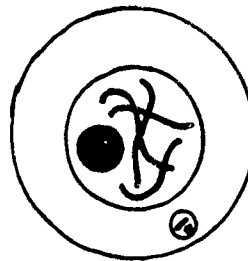

4.

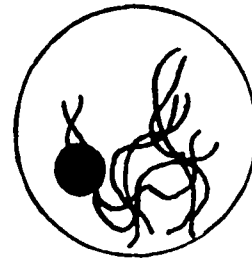

"Contours" (Specific Facts)

1. The contour map shows

- a. location of rivers.
- b. location of mountains, streams, and roads.
- c. steepness of a hill and location of trees.
- d. elevations, steepness of hills, location of land formations, and roads.

2. The picture showed a contour map. The point of view is the same as if a person were

- a. standing on top of the mountain and looking down.
- b. looking straight down at the earth from an airplane.
- c. making slices in the earth.
- d. looking up at the mountain.

3. The distance between the contour lines changes with changes in land form. Lines that are close together show that

- a. the land is steep at this point.
- b. there is a gradual slope up from the beach.
- c. this is the starting point for a mountain.
- d. that the land is flat.

4. The elevation marked zero on a contour map shows
- the lowest flat ground in the area.
 - a sandy beach.
 - the level of the sea.
 - ground that doesn't have any mountain on it.
5. The contour map below has different parts marked with numbers. Read each of the descriptions and put the right number in each blank space.
- 5 the highest elevation
 - 2 steepest part of the mountain
 - 1 zero elevation
 - 4 a line which is not a contour line

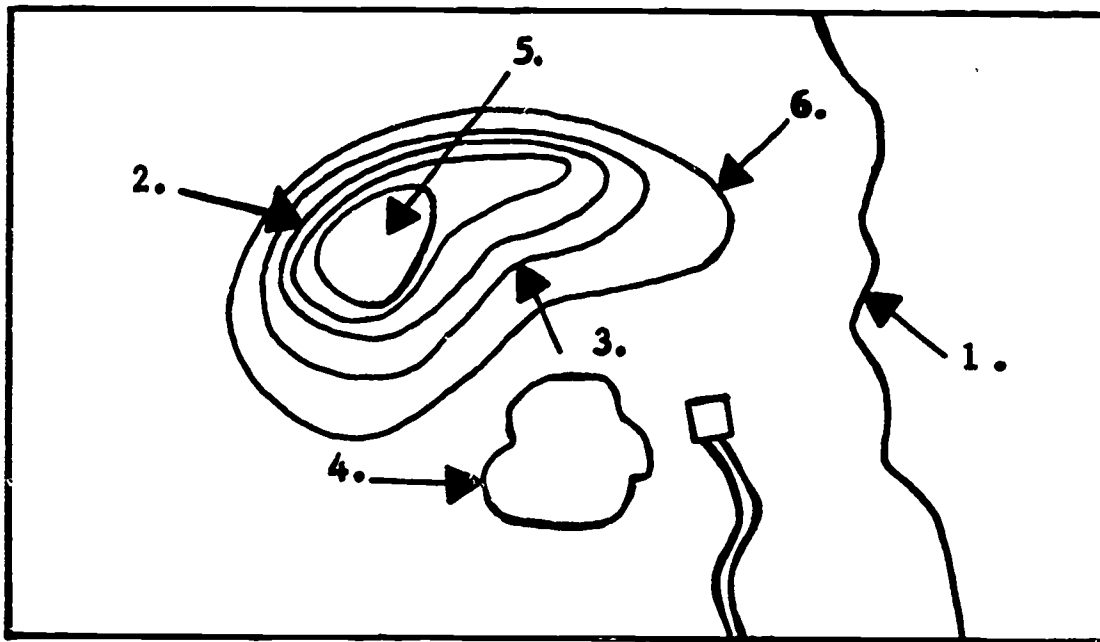

"Plants" (Serial Ordering)

1. Put these three steps in the right order for growing a bean plant.
(Put the numbers 1, 2, and 3 in their right places.) Two of the steps shown are not true and should not be numbered.

a. 2

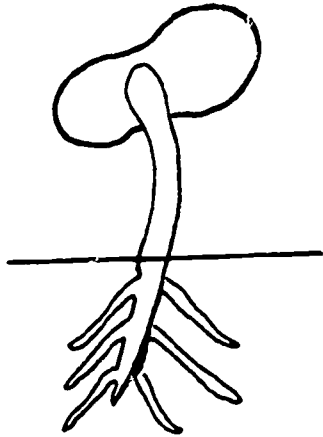

b.

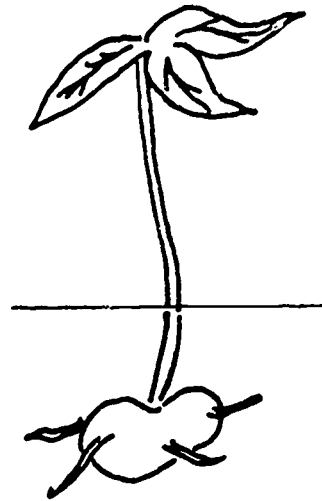

c.



d. 3

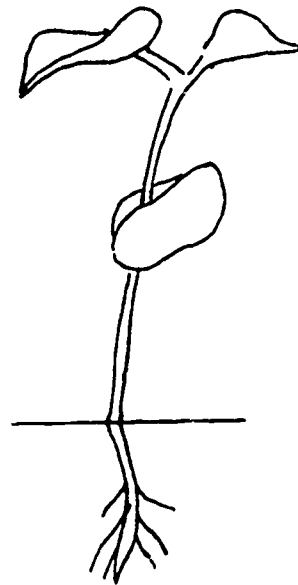

e. 1

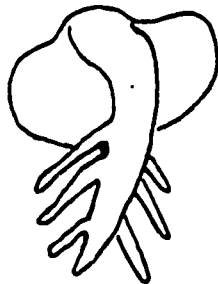

2. Put these four drawings in the right order for a seed planting itself. (Put the numbers 1, 2, 3, and 4 in the spaces.)

a. 2

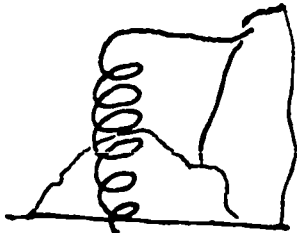

b. 3



c. 1

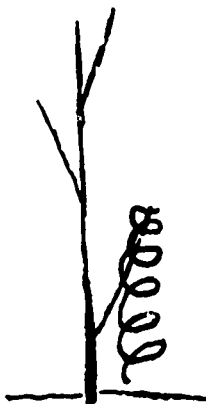

d. 4

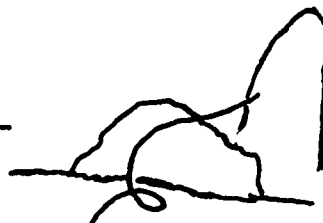

"Filtering" (Serial Ordering)

1. Put these five steps in the right order for filtering a liquid. (Put the numbers 1, 2, 3, 4, and 5 in the spaces.)

- a. 2 wet paper filter with water
- b. 4 clean liquid passes through filter
- c. 1 place folded paper in funnel
- d. 5 wash out container
- e. 3 pour blue mixture into funnel

2. These pictures show how to make a paper filter for a funnel.
(Put the numbers 1, 2, 3, and 4 in front of these steps to show
the right order.) Two of the steps shown are not true and
should not be numbered.

a. 1

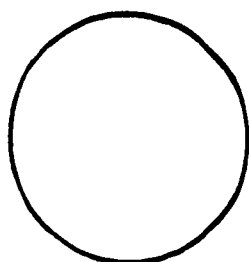

b. 4

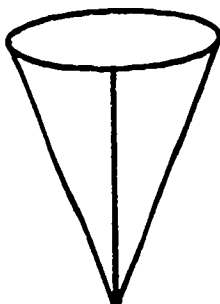

c. 2



d.



e.

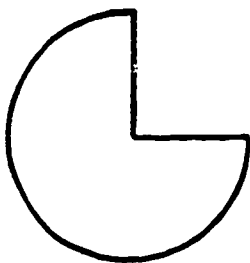

f. 3



3. The man poured two clear liquids together to form a blue substance.
The substance left in the paper filter after the final step was in
the form of

- a. gas moving on top the liquids.
- b. a dark liquid as thick as syrup.
- c. a water-like liquid.
- d. a clear substance.

4. These pictures show the main steps for filtering solids from liquids. Put the numbers 1, 2, and 3 in front of these steps to show the right order.

a. 2

b. 1

c. 3

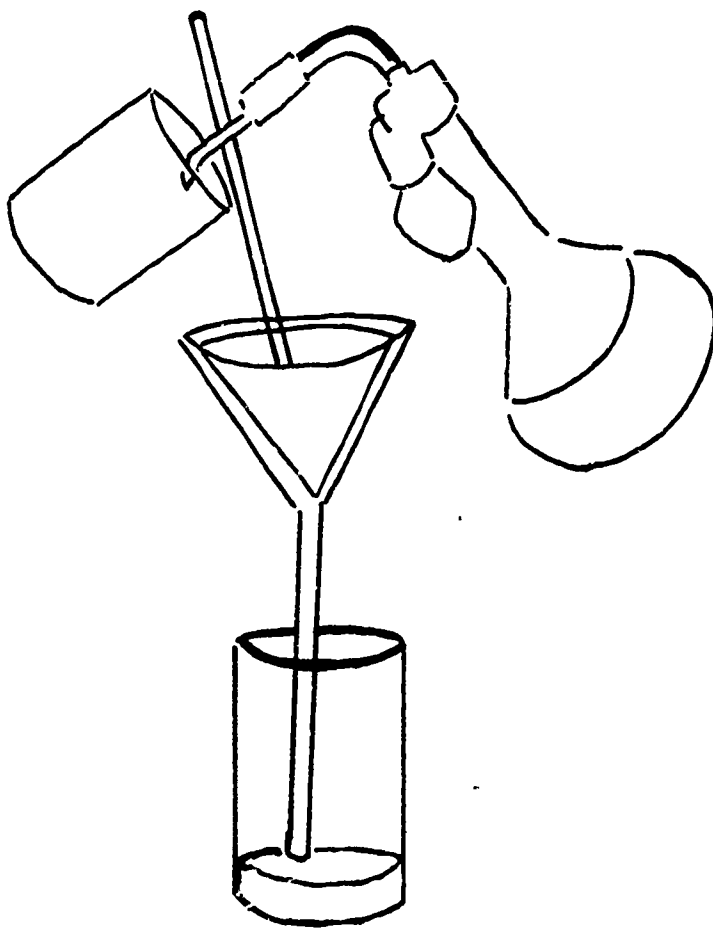
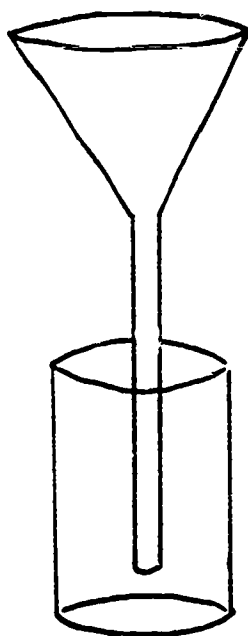
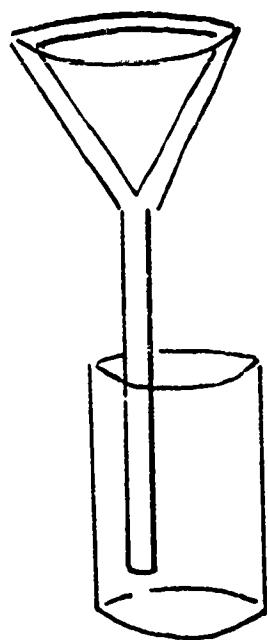

"Tacoma Bridge" (Serial Ordering)

1. The drawing below shows the side of the bridge. Which section of the bridge started to move first? Put the number here: 3.
2. In the drawing below, the greatest movement took place between which two points? Put the number here: (a) 2 or 4 and (b) 2 or 4.

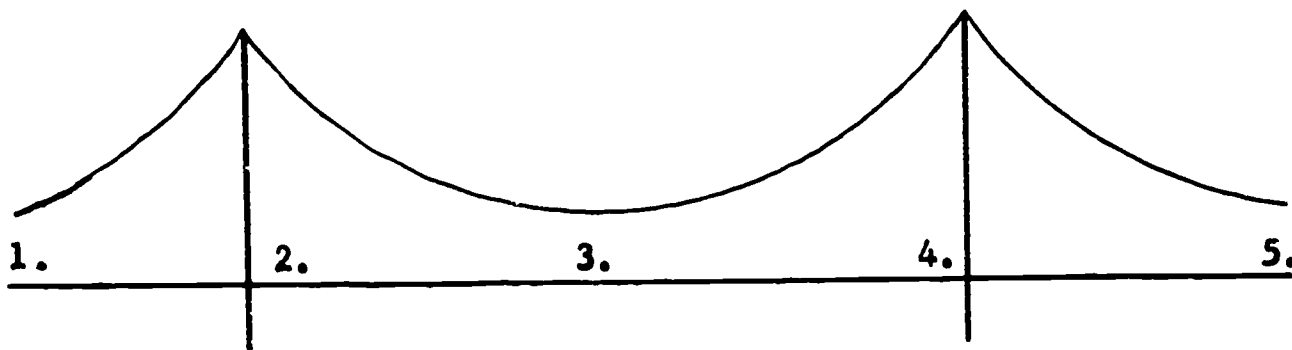

3. Pretend you are standing at the end of the bridge. The dotted line represents the bridge when it is not moving. Pick out a picture that you might have seen during this time.

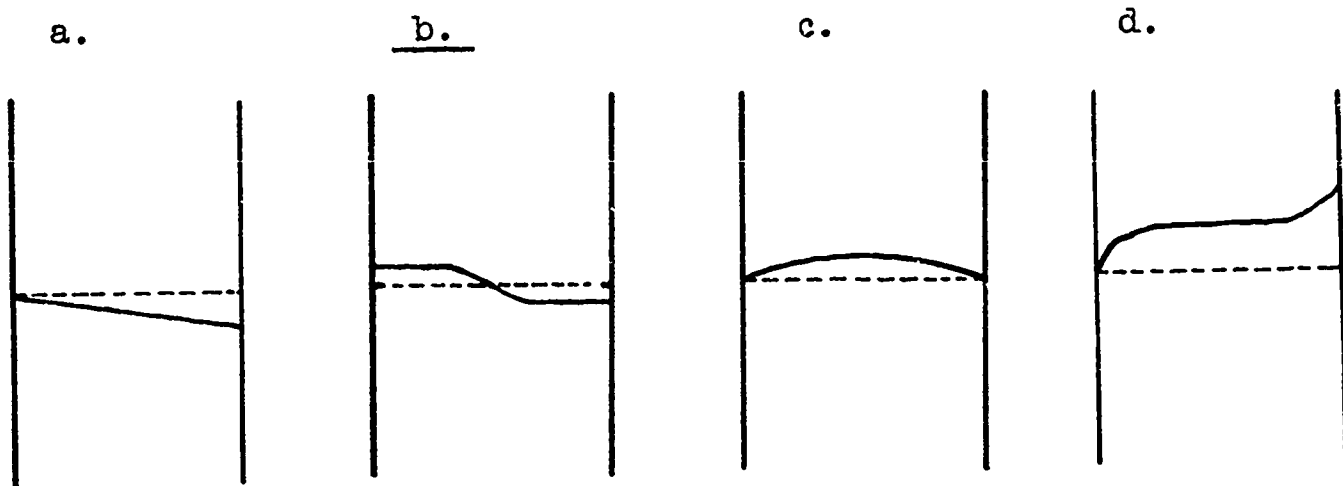

4. Pretend again that you are looking at the side of the bridge. Try to remember the way the bridge moved. Put the number 1 beside the first step, the number 2 beside the second, and 3 beside the third. Two of the steps are not true and should not be numbered.

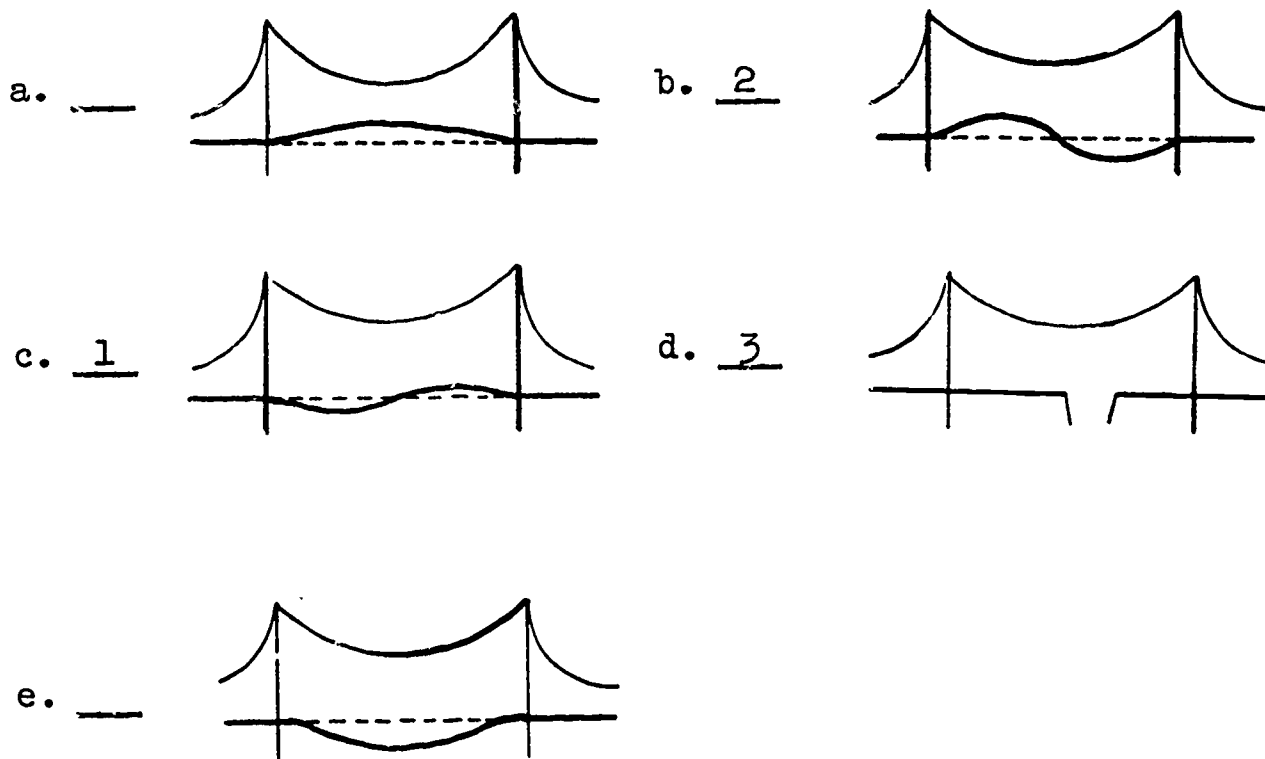

"Steam" (Concepts)

1. Choose a word that describes work done by steam.

- a. pulling
- b. rising
- c. heating
- d. pushing

2. Choose the diagram that shows when the fan will turn the fastest.

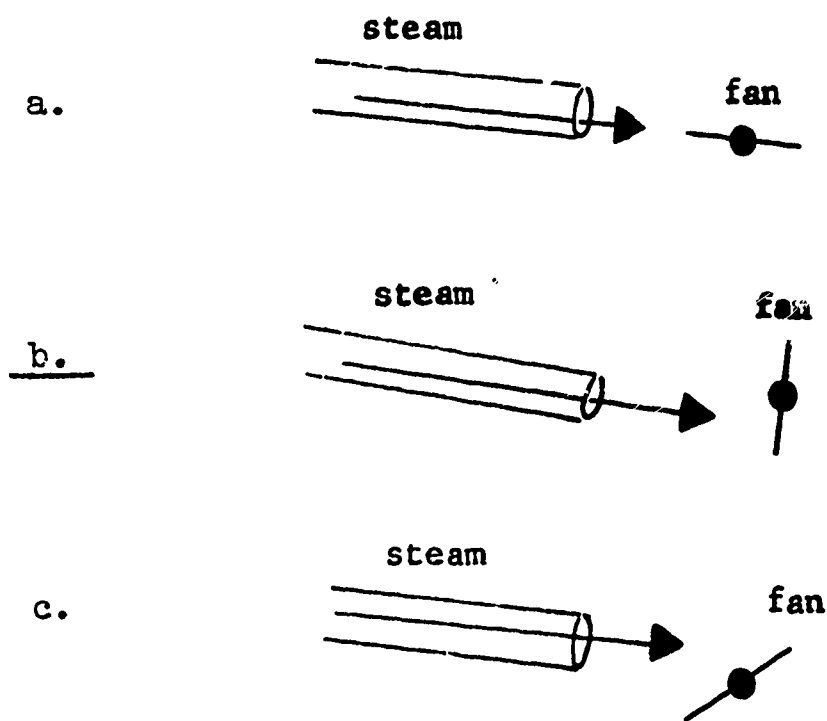

3. Which of the following steps will increase the work done by a steam engine?

- a. shorten the distance between heat source and water
- b. increase the space between heat source and fan blade
- c. lower the temperature of the heat source
- d. remove the heat source

4. In the test tube experiment we saw that

- a. water can not be changed into steam.
- b. steam takes less space than water.
- c. water and steam take the same amount of space.
- d. if water is converted into steam it takes up more space.

5. Which way did the steam motor bottle turn? (Draw a circle around the letter next to the right arrow.)

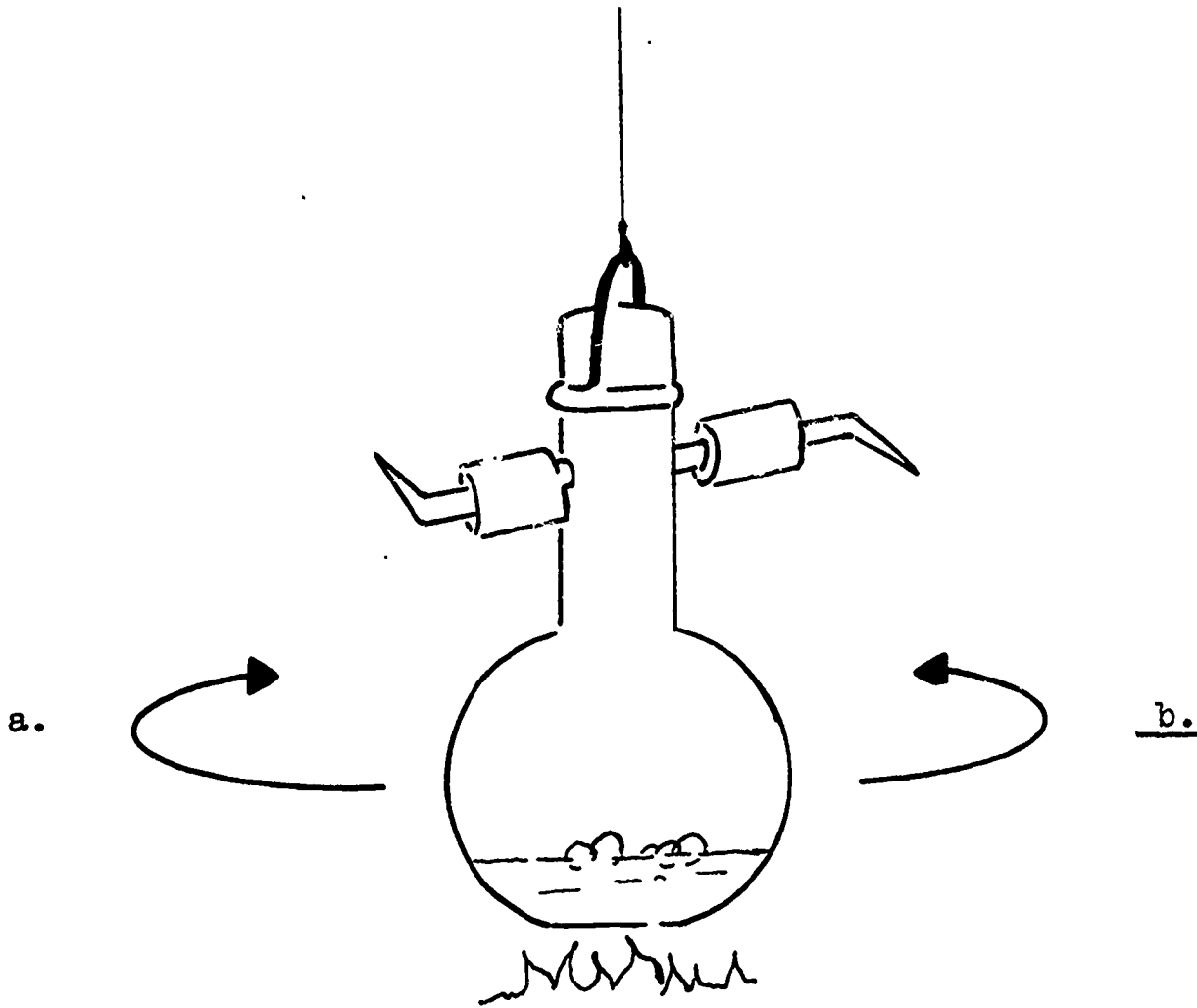

"Dome and Volcanic Mountains" (Concepts)

1. The most important difference between the dome and volcanic type of mountains is
 - a. the thickness of the solid rock below the melted rock.
 - b. an opening in the ground to the source of melted rock.
 - c. the presence of melted rock.
 - d. a layer below the surface which the melted rock can spread on.

2. Here is a drawing of what a slice of the earth might look like from the side? Where do you think the molten rock comes from? (Draw a circle around the letter next to the right area.)

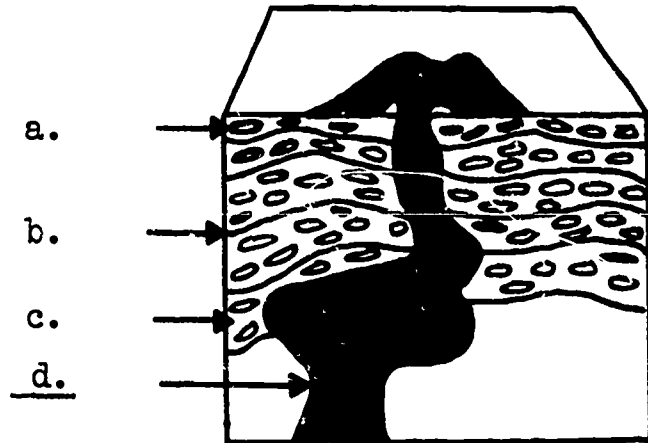

3. Here are some side drawings of the earth. Which one shows how a dome-shaped mountain is made?

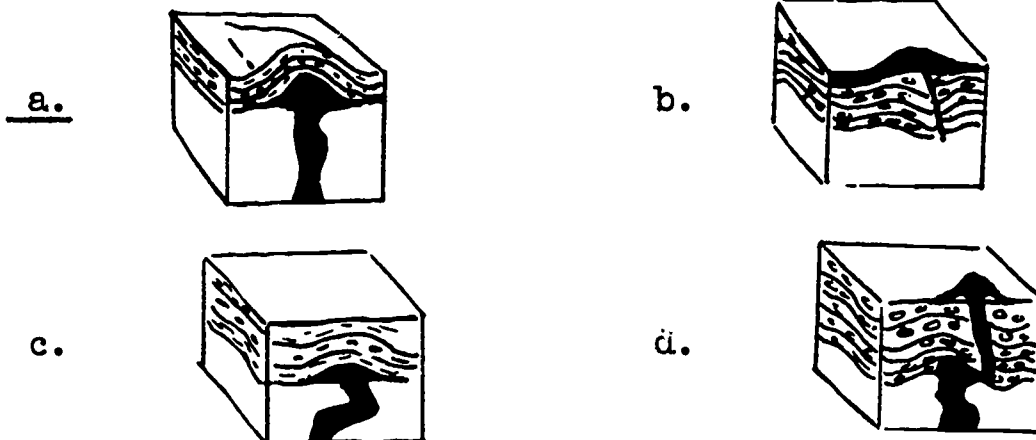

4. If you saw a smooth, dome-shaped mountain, you might say it
- is a volcanic mountain that has erupted recently.
 - is a mountain that was forced up by pressure from below the surface of the earth.
 - is a very old mountain, worn through by snow and water.
 - was formed by cracks in the top layer of the earth.
5. The force that causes dome and volcanic mountains to form is
- openings in the rocks.
 - different layers of rock.
 - rock at different layers.
 - pressure of melted rock.

"Amusement Park" (Concepts)

1. Which of these rides temporarily overcame the pull of gravity?
 - a. roller coaster ride
 - b. rotor ride
 - c. motorcycle
 - d. all of the rides

2. Here is a drawing of the roller coaster ride. Where will the car be traveling the fastest? Put the number here: 4.

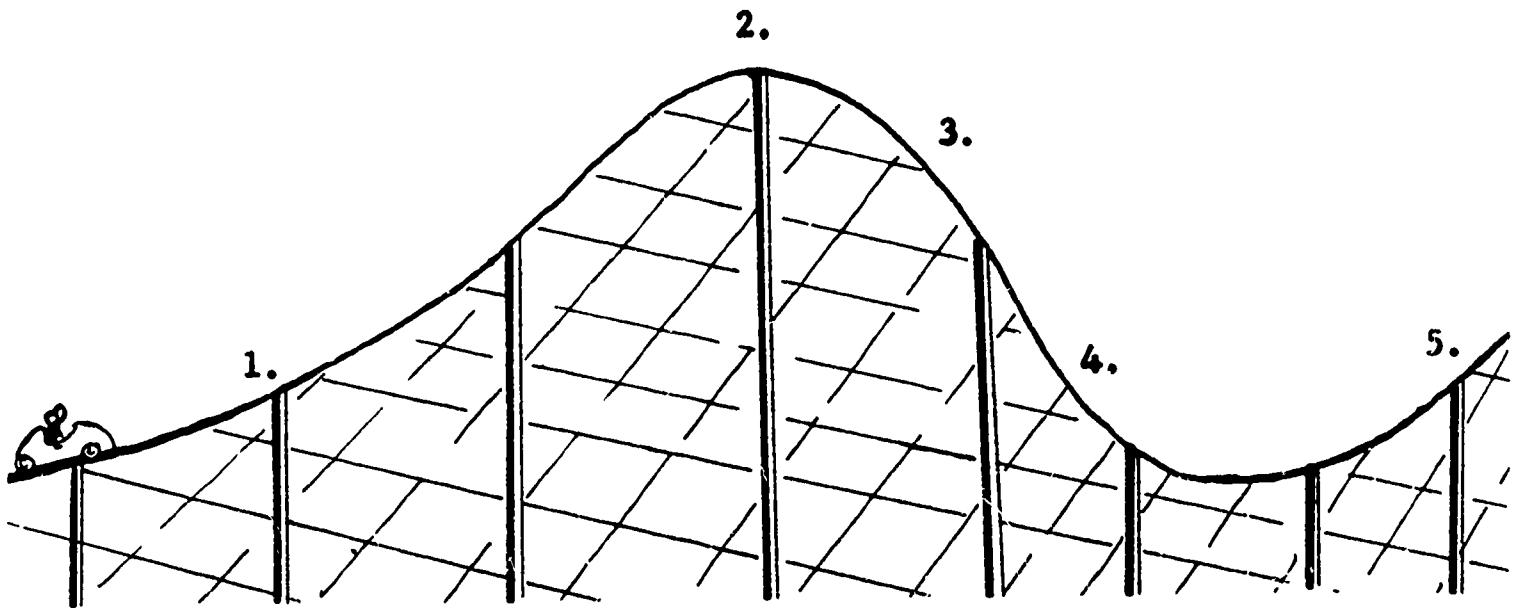

3. In the rotor ride people stood against a wall. If the ride speeded up people would be pulled in direction (a) 3, and if it slowed down they would be pulled in direction (b) 1. (Put the right numbers in the spaces.)

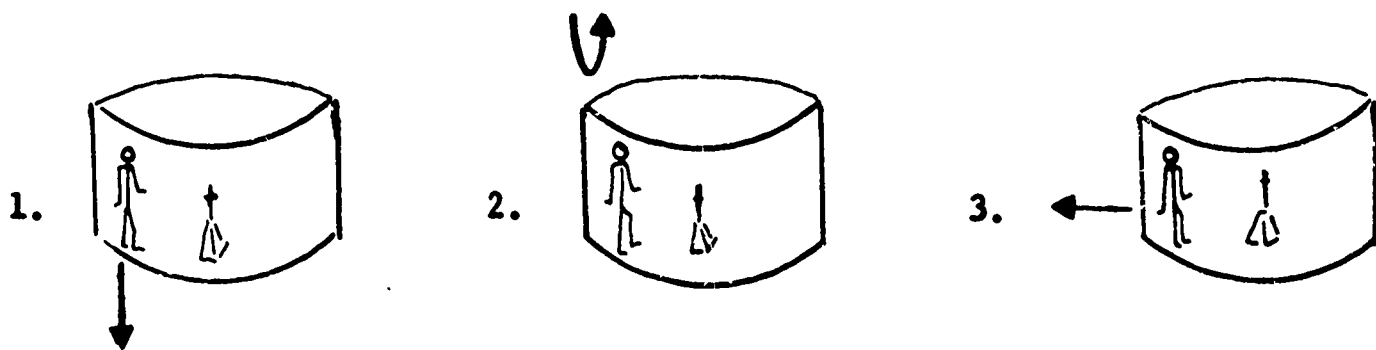

END OF SCIENCE CONTENT TEST

MOTOR SKILL CONTENT

"Tumbling" (Specific Facts)

1. During the head balance position, the girl used her: (Draw a line under one or more right answers.)

a.



b.



c.



d.



e.



2. Pick the drawing which best shows the head balance position.

a.

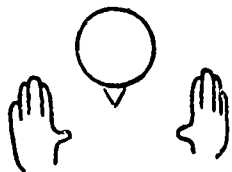

b.

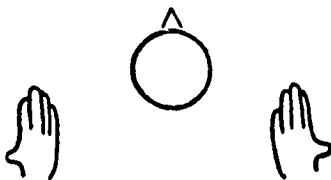

c.

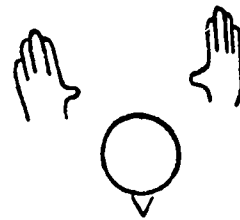

3. (True or False) - The girl changes balance by moving her legs.

4. When did the girl have one foot on the ground?

- a. on the way up
- b. on the way down
- c. before starting
- d. during the head stand

5. During the hand balance position, what body parts touched the ground?
(Draw a line under one or more right answers.)

a.



b.



c.



d.



e.



6. In going from the hand balance position back to the standing position, what body parts touched the ground? (Draw a line under one or more right answers.)

a.



b.



c.



d.



7. Which picture shows the best hand balance form?

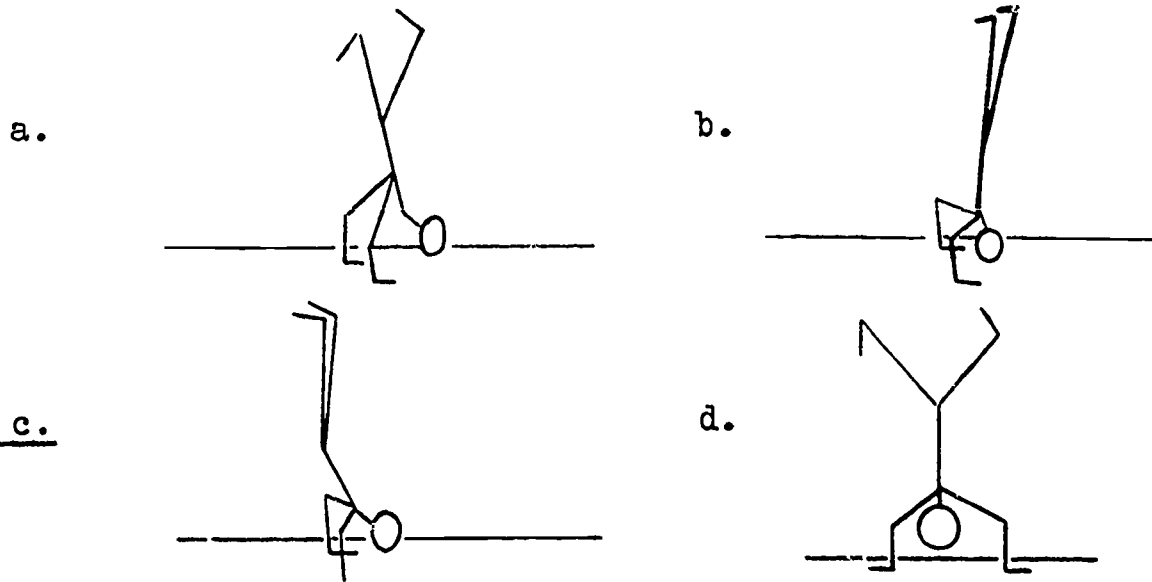

8. When did the girl tuck her head between her arms?

- a. on the way up
- b. on the way down
- c. while standing
- d. when doing the hand balance
- e. none of the above

"Slide Projector" (Specific Facts)

1. If the slide projector is moved closer to the screen, the picture on the screen will

- a. get bigger.
- b. get smaller.
- c. stay the same.
- d. none of the above.

2. Turning the lens will make the picture

- a. become larger.
- b. become sharp and in focus
- c. move up and down.
- d. change to the next slide.

3. The right way to switch on the slide projector is to turn on first the (a) fan and second the (b) lamp .
(Write the right answers in the spaces.)
4. Match the numbers in the diagram to the descriptions given below.
(Beside each picture is a number. Mark the right number in each of the blank spaces.)
- 4 up-down knob
 - 2 lamp and fan switches
 - 3 slide holder
 - 1 focus adjustment

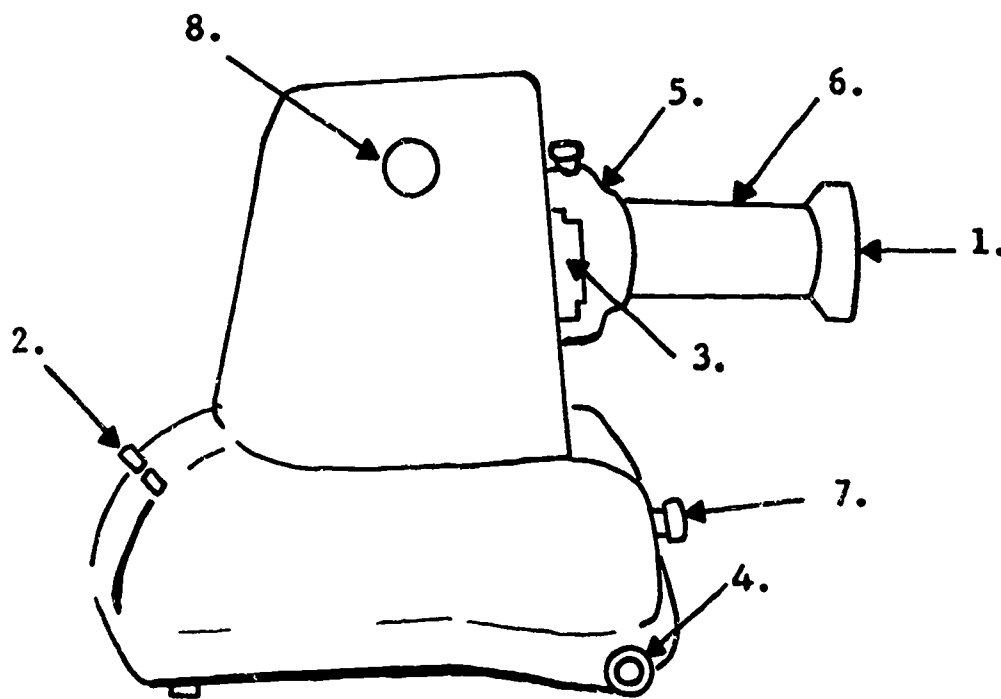

"Shot Put" (Specific Facts)

1. The man swung his right leg around to help him to
- turn.
 - start.
 - move.
 - jump.

2. Once the man has thrown the ball, he turns, which helps him to
- see where the ball lands.
 - keep moving.
 - stop his forward motion.
 - relax his muscles.
3. What action did the man do to make the ball go far?
- threw the ball like a baseball
 - used all his weight
 - paused in the center of the ring
 - used only his arms
4. Where was the ball at the beginning?
- held at his side
 - held at his shoulder
 - held in both of his hands
 - held over his head
5. The man's arm was bent (straight or bent) at the start of the throw? (Put the right answer in the space.)

"Clay Beads" (Serial Ordering)

1. Put these four steps in the right order for making a clay bead. (Put the numbers 1, 2, 3, and 4 in the spaces.)
- 3 roll with fingers
 - 2 roll in palm of hands
 - 1 break off piece of clay
 - 4 make hole with a sharp stick

"Bird's Nest/Cartwheel" (Serial Ordering)

1. Show the right order for performing the bird's nest. (Put the numbers 1, 2, 3, and 4 in the spaces next to the drawings.)

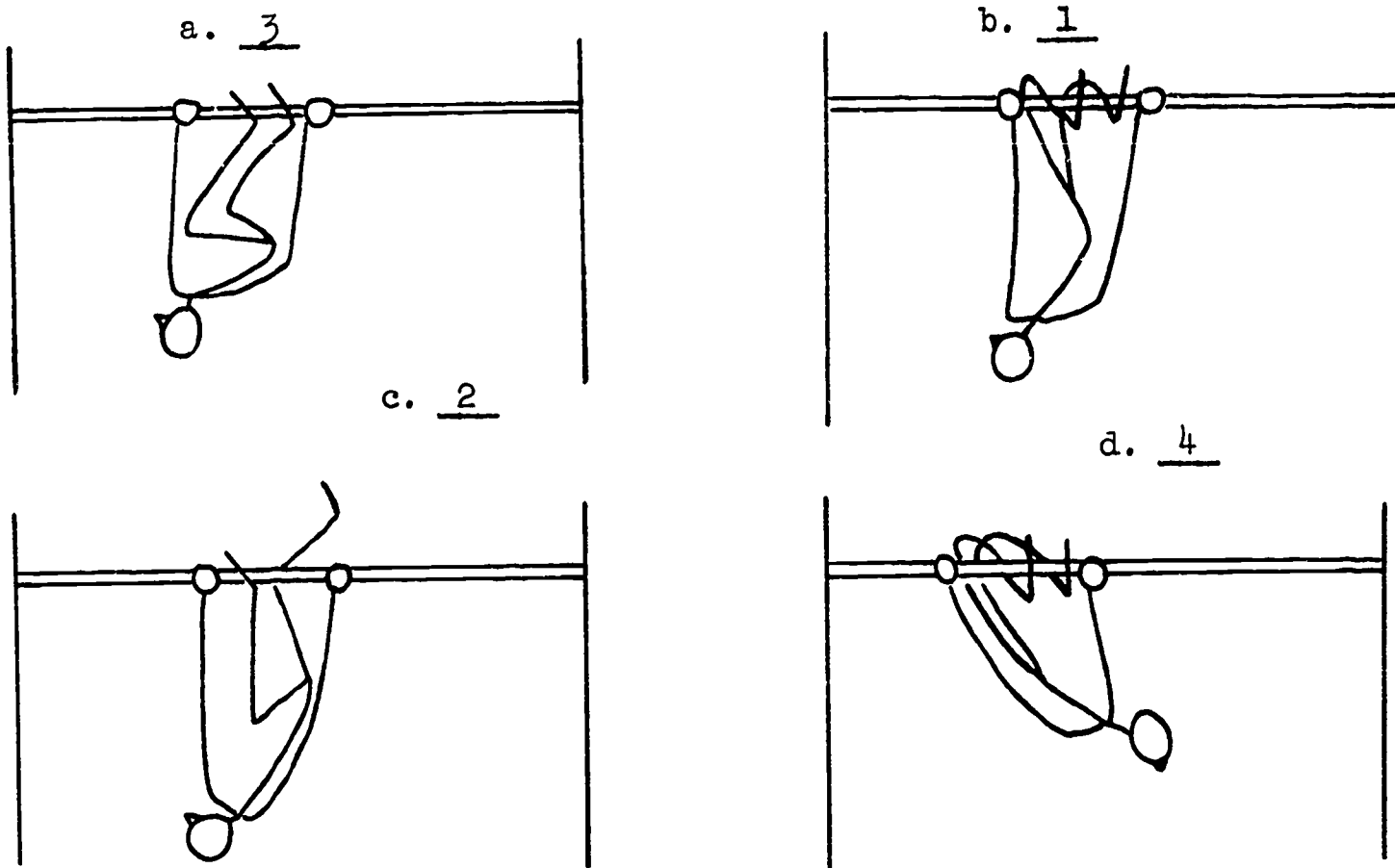

2. Show the right order for doing a cartwheel. (Put the numbers 1, 2, 3, 4, 5, and 6 in the spaces next to the drawings.)

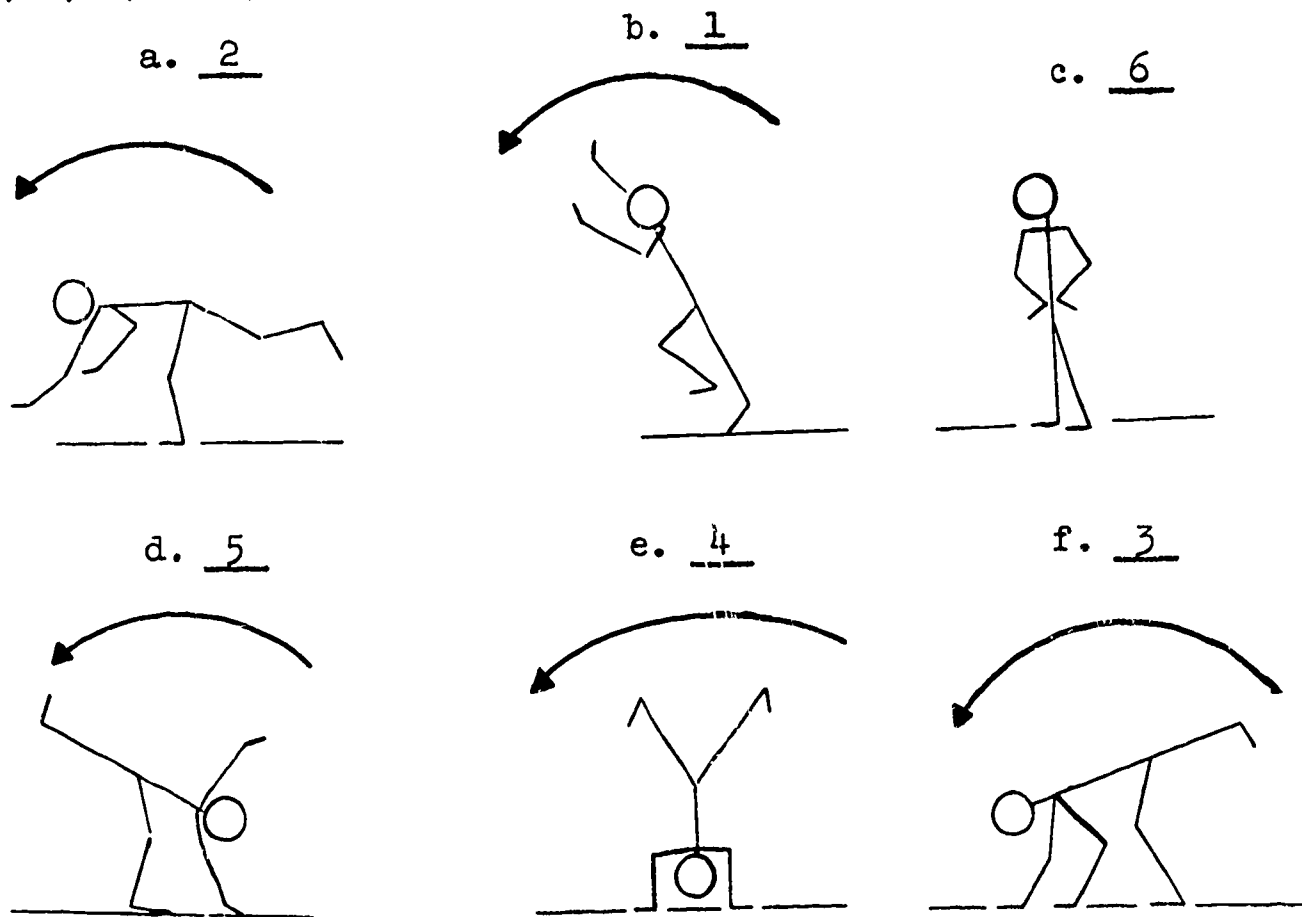

"Motion Picture Projector" (Serial Ordering)

1. Draw a line showing the path through the projector.

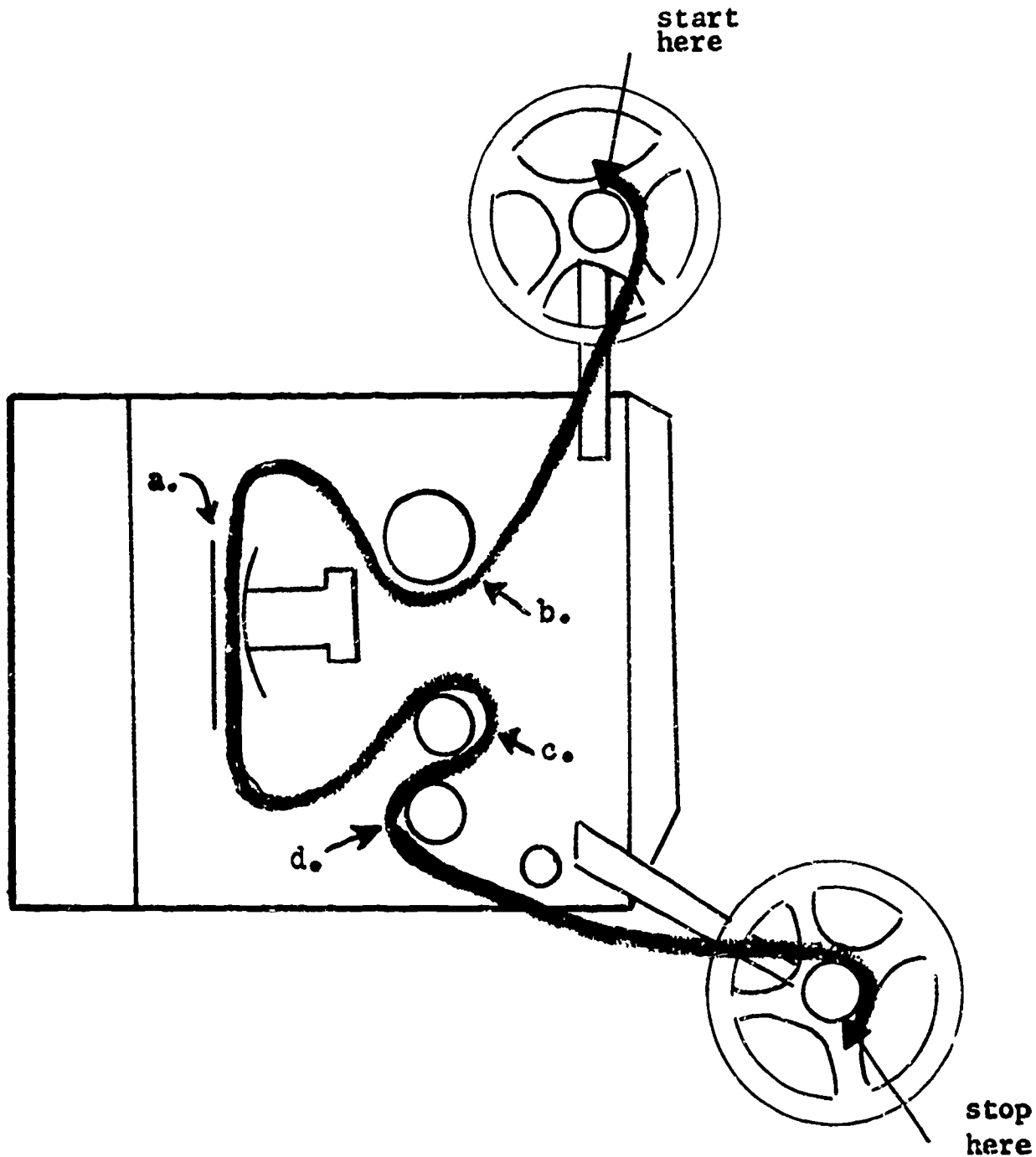

2. The woman prepared the projector for threading by doing the things listed below. Place these steps in the order that she did them. (Put the number 1 beside the first step, 2 beside the second step, and 3 beside the third.)

- a. 3 open and fold back lens
- b. 2 put reel on upper projector arm
- c. 1 put reel on lower projector arm

"Gesture" (Concepts)

1. Pick three answers that best describe the style of the artist.
(Draw a line under the right answers.)
 - a. continuous movement
 - b. stop and go
 - c. scribble
 - d. stiff
 - e. flowing
 - f. detailed

2. The sketches were made in large motions. This was done by moving the
 - a. whole arm and hand.
 - b. wrist and hand.
 - c. fingers.
 - d. body.

3. The artist in the films tried to
 - a. work quickly and carelessly.
 - b. carefully draw all details.
 - c. reproduce the shades and shadows.
 - d. rapidly sketch the general shape.

"Trampoline" (Concepts)

In order for the man to jump high in the air he (Draw a line under either True or False.)...

1. (True or False) turned around quickly.
2. (True or False) quickly straightened his legs.
3. (True or False) swung his arms upward.
4. (True or False) rotated his arms sideways.
5. (True or False) turned his head.

The man used his arms for which of the following purposes? (Draw a line under either True or False.)

6. (True or False) maintaining his balance when jumping
7. (True or False) changing the height of the jump
8. (True or False) pushing against the trampoline
9. (True or False) changing direction and speed while maintaining balance

10. When the man landed on the trampoline, how far down did it move?
(Draw a line under the letter next to the right drawing.)

a.

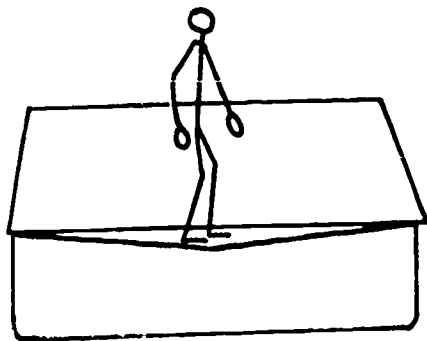

b.

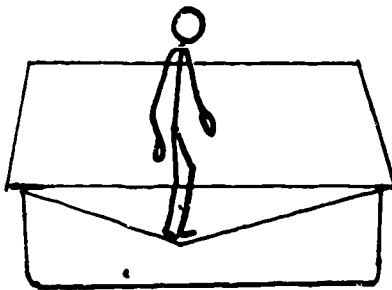

c.

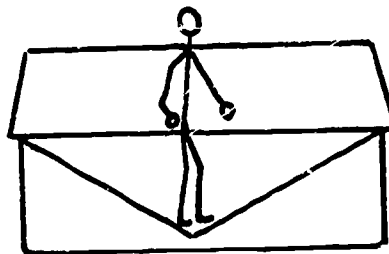

"Experimental Painting" (Concepts)

1. When an artist paints with bleach he is

1. drawing on paper.
2. adding tan coloring to the paper.
3. using a single color.
4. taking color away from the paper.

2. The opposite of painting with bleach is painting with colors,
paint, etc. (Write the correct answer in the space.)

3. Think of the way bleach acted on colored paper! The drawing represents the path of a brush with BLEACH on it. When the brush is at this point, the color paper is darkest at number (a) 5 , and lightest at number (b) 1 . (Write the right numbers in the spaces.)

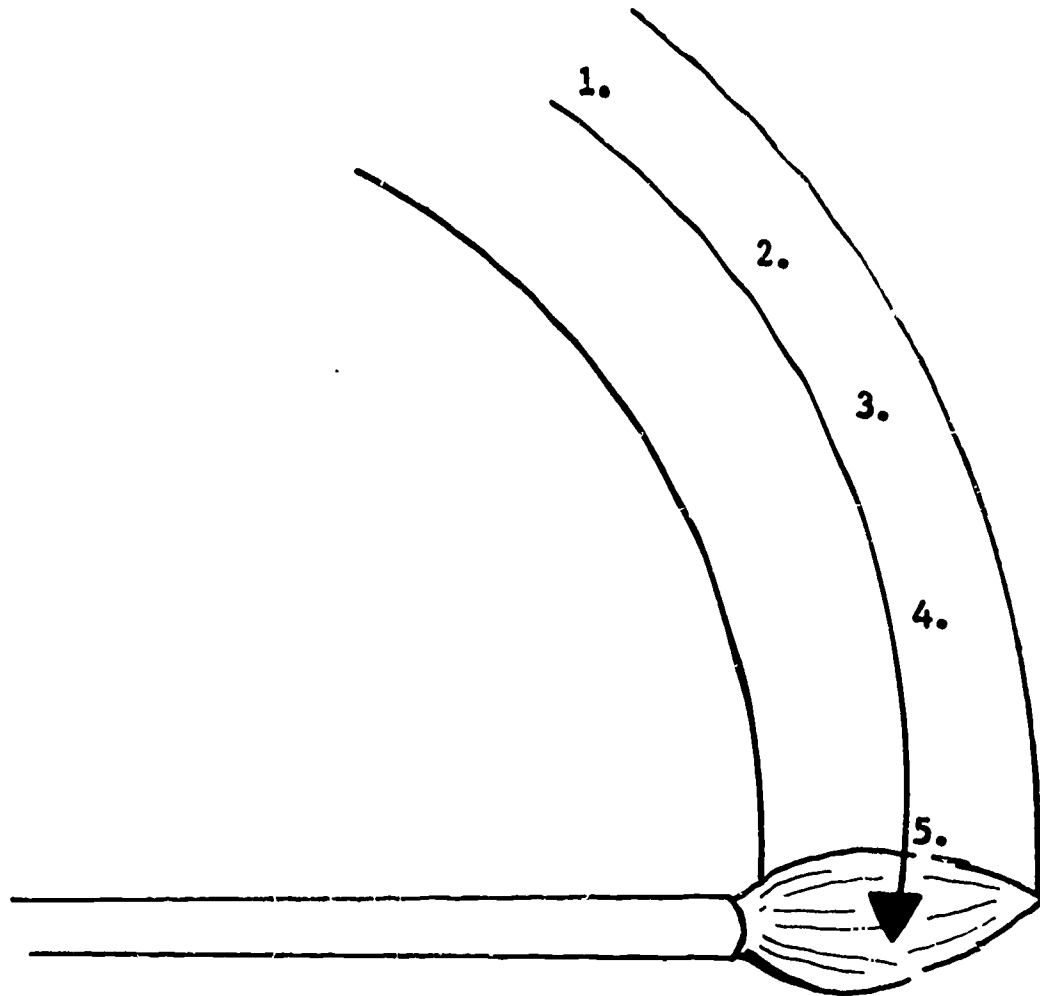

END OF MOTOR SKILL CONTEST TEST

SOCIAL STUDIES CONTENT

"Egyptian Irrigation" (Specific Facts)

1. The pictures below show four water-raising devices. (Draw a circle around those that were shown in the pictures.)
2. Which water-raising method gives the villagers the greatest amount of water in an hour's time? 4 (Choose the drawing below which best answers the question and mark the number in the blank space.)
3. Which water-raising method shown in the pictures does not give a steady flow of water? 1 (Choose the drawing which answers the question and mark the number in the blank space.)
4. Which system would probably be owned by a rich man? 1 (Choose the drawing below which best answers the question and mark the number in the blank space.)

1.

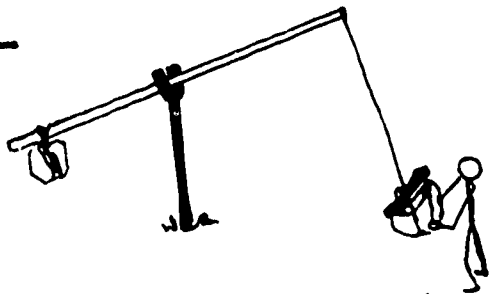

2.

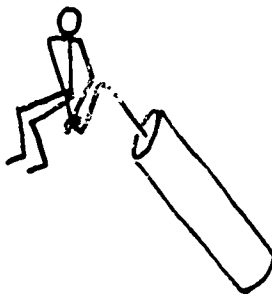

3.

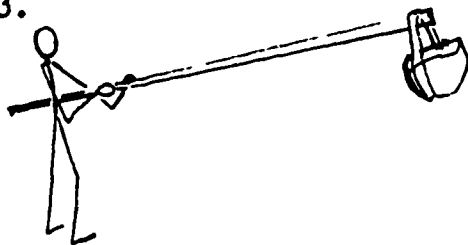

4.

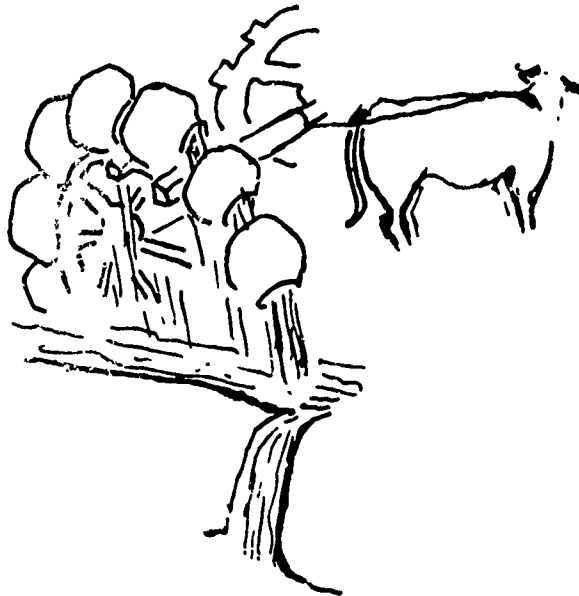

"African City" (Specific Facts)

1. In the African school, what language was being learned?
 - a. Spanish
 - b. English
 - c. French
 - d. African

2. Draw a circle around those jobs that were shown in the picture you just saw. (Draw a line under one or more right answers.)
 - a. office work
 - b. mining
 - c. hospital work
 - d. farming

3. In the picture, people in African cities rode (Draw a line under one or more right answers.) ...
 - a. bicycles.
 - b. motorcycles.
 - c. trucks
 - d. buses.
 - e. horse drawn carts.

"Floating Market" (Specific Facts)

1. Pick the two ways of powering boats in Thailand. (Draw a line under one or more right answers.)
 - a. sail
 - b. motor
 - c. paddle
 - d. towing

2. Pick two ways in which the boat was used in Thailand. (Draw a line under one or more right answers.)
 - a. ferrying people across the river
 - b. as houseboats
 - c. transportation
 - d. as stands for selling products

3. Pick one way in which people determined the price of the food they sold.
 - a. measuring the length
 - b. determining the weight
 - c. judging the package size

"Banana Harvesting" (Serial Ordering)

1. Show the right order in which bananas are harvested. (Put the numbers 1, 2, and 3 in the right spaces.)

2 cut off bananas
1 cover bananas with plastic bag
3 cover with burlap material

2. Show the right order for processing bananas. (Put the numbers 1, 2, 3, 4, 5, and 6 in the right spaces.)

5 package
4 label
3 sort
2 soak and cut apart
6 stack boxes
1 hang banana stalks on rack

"Copra" (Serial Ordering)

1. Below are listed several steps in harvesting coconut. Arrange the steps in the order that they took place. (Put a number 1 beside the first step, number 2 beside the second step, and number 3 beside the third step.)

3 remove coconut meat from shell
1 rip off outer covering of coconut and load in baskets
2 divide coconuts in half

2. In harvesting the coconut, which of these tools was used first, second, third, and fourth? (Put the numbers 1, 2, 3, and 4 in the spaces next to the drawings.)

a. 2



b. 1

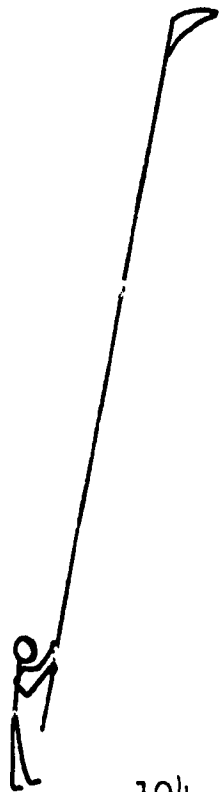

104

c. 3

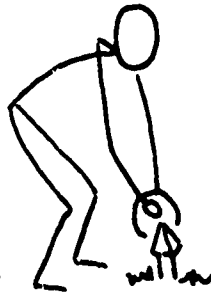

d. 4



"Lumbering" (Serial Ordering)

1. In the drawing below, the numbered arrows show the different places a tree is cut. (Put the numbers in the order that the cuts were made.)

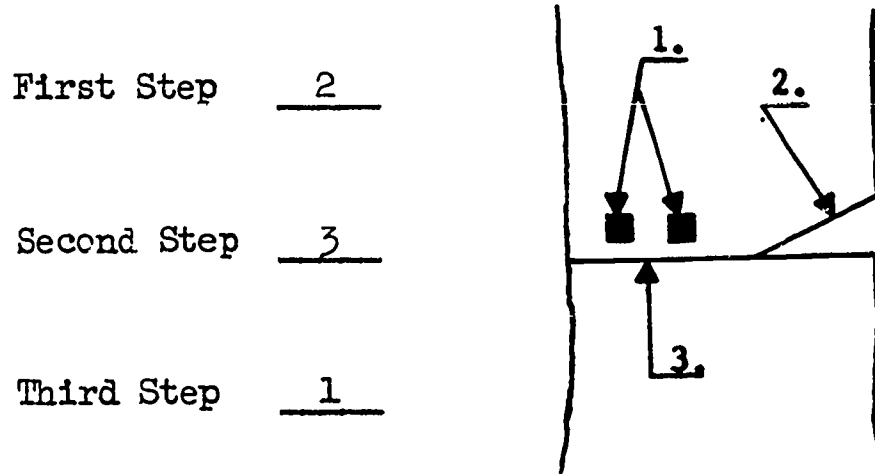

2. Arrange the steps for getting logs out of the forest. (Put number 1 beside the first step, number 2 beside the second step, and so on.)

 2 notch the tree
 3 elephant drags
 1 cut the tree
 4 truck tows

3. Below are listed four steps in making boards from logs. (Put number 1 beside the first step, number 2 beside the second step, and so on.)

 4 stack wood to dry in the sun
 3 cut to right length
 1 remove bark
 2 cut into planks

"African Village" (Concepts)

1. The picture showed how people who live in villages

a. raise cattle.
b. build houses.
c. farm the land.
d. all of the above.

2. In the picture you saw, the music was

a. very slow
b. slow
c. fast

3. Which two things were probably made outside the village?
(Draw a line under one or more right answers.)
- a. metal water buckets
 - b. farm tools
 - c. houses
4. In the picture you saw people getting water from
- a. water tank.
 - b. ground.
 - c. river.
 - d. water faucet.
5. Pick three modern improvements which would probably be of the greatest value to the villagers. (Draw a line under one or more right answers.)
- a. street sweeping machine
 - b. water pumping system
 - c. brick making machine
 - d. music amplifier
 - e. indoor plumbing system

"Eastern Europe and Middle America" (Concepts)

1. Compare the farming capacity of Eastern Europe and Middle America. If there was a sudden demand for more food, Eastern Europe (Eastern Europe or Middle America) could respond faster. (Write the correct answer in the blank space.)
2. Machine automation techniques are used with most jobs in Eastern Europe (Eastern Europe or Middle America). (Write the correct answer in the blank space.)
3. Pretend you are a scientist trying to find out about the cultures in Eastern Europe and Middle America. You have found several objects from each of these areas. Mark an M.A. (Middle America) or E.E. (Eastern Europe) in each of the blank spaces to identify where they were found.

<u>E.E.</u>	trucks
<u>M.A.</u>	hand weaving looms
<u>E.E.</u>	tractor
<u>M.A.</u>	ox-driven plow
<u>E.E.</u>	crane
<u>E.E.</u>	power tools

4. Mark an M.A. (middle America) or E.E. (Eastern Europe) in the blank spaces in front of the words which best describe each area.

E.E. industrial
E.E. city
M.A. primitive
E.E. automation
M.A. country

"Transportation in India" (Concepts)

If you were trying to shorten the travel time along India's roads, which changes would you make? (Draw a line under each right answer-- either True or False.)

1. (True or False) - make vehicles stay on their own side of the road
2. (True or False) - pave all the roads
3. (True or False) - keep cattle off the road
4. (True or False) - have animal carts, camels, and trucks use the same road

Draw a line under the right answer below - True or False.

5. (True or False) - In India, food is generally produced locally because transportation is poor.

Several reasons for using animals rather than trucks are (Draw a line under each right answer - either True or False.) ...

6. (True or False) - trucks are expensive.
7. (True or False) - animals are faster.
8. (True or False) - animals have no repair problems.
9. In India, which store would probably have the most business?
 - a. gas station
 - b. garage
 - c. saddle shop
 - d. travel agent

END OF SOCIAL STUDIES CONTENT TEST

APPENDIX C

TABLE 12

RESULTS OF ANALYSIS BY TREATMENT GROUPS FOR MALE AND FEMALE SUBJECTS
(FIFTH GRADE)

	Male			Female		
	df	F	Prob.	df	F	Prob.
<u>SCIENCE</u>						
<u>Specific Facts</u>						
Nuclear Reactions	2/26	.353	--	2/36	2.279	--
Cells	2/26	.771	--	2/36	1.026	--
Contours	2/26	2.451	--	2/36	1.414	--
<u>Serial Ordering</u>						
Plants	2/26	4.117	<.05	2/36	17.325	<.001
Filtering	2/26	6.039	<.01	2/36	2.937	<.10
Tacoma Bridge	2/26	1.385	--	2/36	.245	--
<u>Concepts</u>						
Steam	2/26	1.838	--	2/36	6.053	<.01
Dome & Volcanic Mts.	2/26	1.413	--	2/36	2.133	--
Amusement Park	2/26	.088	--	2/36	1.593	--
<u>MOTOR SKILLS</u>						
<u>Specific Facts</u>						
Tumbling	2/32	2.353	--	2/50	1.331	--
Slide Projector	2/32	3.430	<.05	2/50	2.907	<.10
Shot Put	2/32	1.996	--	2/50	4.391	<.025
<u>Serial Ordering</u>						
Clay Beads	2/32	1.837	--	2/50	2.383	--
Bird's Nest/Cartwheel	2/32	.236	--	2/50	3.338	<.05
Motion Picture Projector	2/32	.069	--	2/50	9.067	<.001
<u>Concepts</u>						
Gesture	2/32	1.430	--	2/50	.714	--
Trampoline	2/32	.620	--	2/50	.315	--
Experimental Painting	2/32	.013	--	2/50	2.095	--
<u>SOCIAL STUDIES</u>						
<u>Specific Facts</u>						
Egypt Irrigation	2/39	6.122	<.005	2/47	10.951	<.001
African City	2/39	1.434	--	2/47	.789	--
Floating Market	2/39	3.233	<.05	2/47	1.263	--
<u>Serial Ordering</u>						
Banana Harvesting	2/39	7.441	<.005	2/47	16.365	<.001
Copra	2/39	5.084	<.025	2/47	1.542	--
Lumbering	2/39	2.113	--	2/47	1.623	--
<u>Concepts</u>						
African Village	2/39	2.636	<.10	2/47	3.986	<.05
East. Europe/Midd. Amer.	2/39	.367	--	2/47	.691	--
Transportation in India	2/39	.688	--	2/47	.889	--

TABLE 13

RESULTS OF ANALYSIS BY TREATMENT GROUPS FOR MALE AND FEMALE SUBJECTS
(SIXTH GRADE)

	Male			Female		
	df	F	Prob.	df	F	Prob.
<u>SCIENCE</u>						
<u>Specific Facts</u>						
Nuclear Reactions	2/52	.644	--	2/55	.170	--
Cells	2/52	.838	--	2/55	.590	--
Contours	2/52	.810	--	2/55	.917	--
<u>Serial Ordering</u>						
Plants	2/52	1.837	--	2/55	13.625	<.001
Filtering	2/52	18.618	<.001	2/55	6.156	<.005
Tacoma Bridge	2/52	5.319	<.01	2/55	1.366	--
<u>Concepts</u>						
Steam	2/52	7.600	<.005	2/55	1.017	--
Dome & Volcanic Mts.	2/52	3.201	<.05	2/55	.211	--
Amusement Park	2/52	1.722	--	2/55	.427	--
<u>MOTOR SKILLS</u>						
<u>Specific Facts</u>						
Tumbling	2/46	1.940	--	2/62	4.076	<.025
Slide Projector	2/46	.731	--	2/62	3.424	<.05
Shot Put	2/46	1.487	--	2/62	2.209	--
<u>Serial Ordering</u>						
Clay Beads	2/46	1.370	--	2/62	1.331	--
Bird's Nest/Cartwheel	2/46	6.723	<.005	2/62	3.535	<.05
Motion Picture Projector	2/46	.456	--	2/62	6.177	<.005
<u>Concepts</u>						
Gesture	2/46	.801	--	2/62	1.985	--
Trampoline	2/46	.429	--	2/62	.200	--
Experimental Painting	2/46	.017	--	2/62	.314	--
<u>SOCIAL STUDIES</u>						
<u>Specific Facts</u>						
Egypt Irrigation	2/52	.794	--	2/49	30.114	<.001
African City	2/52	.329	--	2/49	8.908	<.001
Floating Market	2/52	2.740	<.10	2/49	9.773	<.001
<u>Serial Ordering</u>						
Banana Harvesting	2/52	8.836	<.001	2/49	7.396	<.005
Copra	2/52	1.266	--	2/49	.596	--
Lumbering	2/52	.804	--	2/49	1.526	--
<u>Concepts</u>						
African Village	2/52	3.702	<.05	2/49	5.566	<.01
East. Europe/Midd. Amer.	2/52	.575	--	2/49	.726	--
Transportation in India	2/52	.172	--	2/49	.849	--

TABLE 14
TOTAL PERFORMANCE TEST MEAN SCORES FOR MALE AND FEMALE GROUPS
(FIFTH GRADE)

	Male			Female		
	MP	Seq	Still	MP	Seq	Still
<u>SCIENCE</u>						
<u>Specific Facts</u>						
Nuclear Reactions	3.08	3.11	2.50	2.47	2.00	3.46
Cells	3.44	3.50	2.67	4.15	3.91	3.20
Contours	4.88	4.08	3.44	3.73	3.20	2.69
<u>Serial Ordering</u>						
Plants	4.83	1.89	1.88	6.33	1.85	2.09
Filtering	10.11	7.25	6.00	9.23	8.09	6.73
Tacoma Bridge	5.88	4.17	5.11	4.55	4.13	4.77
<u>Motor Skills</u>						
Steam	3.08	3.11	2.25	2.53	1.31	1.55
Dome & Volcanic Mts.	3.11	2.63	3.42	2.39	3.28	2.80
Amusement Park	2.38	2.25	2.44	1.91	2.47	1.92
<u>MOTOR SKILLS</u>						
<u>Specific Facts</u>						
Tumbling	15.00	13.13	13.30	13.75	12.40	12.61
Slide Projector	5.44	4.40	6.44	5.93	4.72	5.70
Shot Put	2.30	3.22	2.38	2.83	2.60	1.80
<u>Serial Ordering</u>						
Clay Beads	6.11	4.44	4.90	6.35	5.33	5.28
Bird's Nest/Cartwheel	4.75	5.30	4.33	5.80	3.39	4.60
Motion Picture Proj.	4.40	4.33	4.19	4.17	3.30	1.87
<u>Concepts</u>						
Gesture	5.11	4.50	3.90	4.80	4.53	4.17
Trampoline	6.44	5.70	6.78	6.87	7.11	6.65
Experimental Painting	1.70	1.78	1.75	2.39	1.75	2.40
<u>SOCIAL STUDIES</u>						
<u>Specific Facts</u>						
Egypt Irrigation	5.77	4.27	4.57	5.85	3.85	4.18
African City	8.00	8.36	7.39	7.62	6.94	7.35
Floating Market	9.14	7.39	6.87	8.00	7.50	7.23
<u>Serial Ordering</u>						
Banana Harvesting	6.31	3.27	4.29	7.00	3.62	3.47
Copra	5.73	3.50	4.23	4.77	3.77	3.80
Lumbering	7.00	5.15	5.60	7.41	6.10	6.31
<u>Concepts</u>						
African Village	7.85	7.73	6.07	8.95	6.92	7.88
East. Europe/Midd. Amer.	3.69	3.00	4.08	4.54	6.35	5.50
Transportation in India	6.29	6.39	6.87	6.47	7.00	6.39

TABLE 15

TOTAL PERFORMANCE TEST MEAN SCORES FOR MALE AND FEMALE GROUPS
(SIXTH GRADE)

	Male			Female		
	MP	Seq	Still	MP	Seq	Still
<u>SCIENCE</u>						
<u>Specific Facts</u>						
Nuclear Reactions	3.42	3.00	3.62	3.28	3.21	2.95
Cells	4.20	3.88	3.47	3.79	3.24	3.78
Contours	4.38	4.16	4.85	3.24	3.28	3.84
<u>Serial Ordering</u>						
Plants	4.58	3.65	2.69	5.56	2.63	2.24
Filtering	11.65	7.81	6.63	10.32	7.86	7.11
Tacoma Bridge	6.06	4.05	4.85	5.10	4.72	4.11
<u>Motor Skills</u>						
Steam	3.63	2.60	1.94	2.56	2.00	2.14
Dome & Volcanic Mts.	3.55	2.81	2.74	3.11	2.86	2.89
Amusement Park	2.50	1.95	2.40	2.05	2.28	2.32
<u>MOTOR SKILLS</u>						
<u>Specific Facts</u>						
Tumbling	14.05	12.64	12.44	14.00	12.39	14.35
Slide Projector	5.07	5.38	5.84	5.65	4.75	6.05
Shot Put	3.19	2.74	2.50	3.05	2.41	2.48
<u>Serial Ordering</u>						
Clay Beads	5.63	4.57	5.63	6.05	5.61	5.10
Bird's Nest/Cartwheel	6.14	2.88	5.58	5.57	3.50	4.82
Motion Picture Proj.	5.13	5.00	4.50	4.90	3.59	2.96
<u>Concepts</u>						
Gesture	5.21	4.50	4.50	5.18	4.39	4.20
Trampoline	6.43	6.88	7.00	6.57	6.85	6.82
Experimental Painting	1.94	2.00	2.00	2.15	2.09	1.87
<u>SOCIAL STUDIES</u>						
<u>Specific Facts</u>						
Egypt Irrigation	5.89	5.32	5.39	6.20	4.63	3.17
African City	7.84	8.11	8.17	7.74	6.72	8.53
Floating Market	9.11	7.61	8.11	9.22	7.47	6.79
<u>Serial Ordering</u>						
Banana Harvesting	6.94	5.21	4.00	6.53	4.11	3.83
Copra	5.42	4.61	4.78	5.11	5.06	4.53
Lumbering	7.39	7.11	6.42	7.39	7.00	6.00
<u>Concepts</u>						
African Village	9.11	8.47	7.67	8.93	7.11	7.11
East. Europe/Midd. Amer.	9.42	8.50	7.94	7.58	8.22	6.40
Transportation in India	6.72	6.89	7.05	7.33	7.27	6.74

TABLE 16

RESULTS OF ANALYSIS BY TREATMENT GROUPS FOR HIGH AND
LOW VERBAL SCAT GROUPS (FIFTH GRADE)

	High Verbal SCAT			Low Verbal SCAT		
	df	F	Prob.	df	F	Prob.
<u>SCIENCE</u>						
<u>Specific Facts</u>						
Nuclear Reactions	2/38	.441	--	2/24	1.151	--
Cells	2/38	.906	--	2/24	.939	--
Contours	2/38	1.904	--	2/24	2.620	<.10
<u>Serial Ordering</u>						
Plants	2/38	8.290	<.005	2/24	10.055	<.001
Filtering	2/38	6.330	<.005	2/24	1.984	--
Tacoma Bridge	2/38	.201	--	2/24	2.310	--
<u>Concepts</u>						
Steam	2/38	1.764	--	2/24	2.695	<.10
Dome & Volcanic Mts.	2/38	2.393	--	2/24	.398	--
Amusement Park	2/38	1.781	--	2/24	.500	--
<u>MOTOR SKILLS</u>						
<u>Specific Facts</u>						
Tumbling	2/43	2.283	--	2/39	.640	--
Slide Projector	2/43	4.406	<.025	2/39	1.520	--
Shot Put	2/43	2.165	--	2/39	2.493	<.10
<u>Serial Ordering</u>						
Clay Beads	2/43	3.358	<.05	2/39	1.442	--
Bird's Nest/Cartwheel	2/43	2.603	<.10	2/39	.013	--
Motion Picture Projector	2/43	1.297	--	2/39	2.902	<.10
<u>Concepts</u>						
Gesture	2/43	.632	--	2/39	1.183	--
Trampoline	2/43	.085	--	2/39	.082	--
Experimental Painting	2/43	.241	--	2/39	1.077	--
<u>SOCIAL STUDIES</u>						
<u>Specific Facts</u>						
Egypt Irrigation	2/47	19.944	<.001	2/39	1.466	--
African City	2/47	1.282	--	2/39	.149	--
Floating Market	2/47	1.219	--	2/39	3.623	<.05
<u>Serial Ordering</u>						
Banana Harvesting	2/47	15.013	<.001	2/39	6.924	<.005
Copra	2/47	.508	--	2/39	10.135	<.001
Lumbering	2/47	2.687	<.10	2/39	2.285	--
<u>Concepts</u>						
African Village	2/47	2.654	<.10	2/39	1.190	--
East. Europe/Midd. Amer.	2/47	.713	--	2/39	.001	--
Transportation in India	2/47	.329	--	2/39	.049	--

TABLE 17

RESULTS OF ANALYSIS BY TREATMENT GROUPS FOR HIGH AND LOW VERBAL
LORGE-THORNDIKE INTELLIGENCE TEST SCORES (SIXTH GRADE)

	High Verbal L-T			Low Verbal L-T		
	df	F	Prob.	df	F	Prob.
<u>SCIENCE</u>						
<u>Specific Facts</u>						
Nuclear Reactions	2/48	.379	--	2/59	.268	--
Cells	2/48	.016	--	2/59	1.523	--
Contours	2/48	1.130	--	2/59	.749	--
<u>Serial Ordering</u>						
Plants	2/48	19.131	<.001	2/59	1.606	--
Filtering	2/48	10.883	<.001	2/59	13.226	<.001
Tacoma Bridge	2/48	2.541	<.10	2/59	2.210	--
<u>Concepts</u>						
Steam	2/48	3.346	<.05	2/59	5.515	<.01
Dome & Volcanic Mts.	2/48	.691	--	2/59	1.777	--
Amusement Park	2/48	.312	--	2/59	1.209	--
<u>MOTOR SKILLS</u>						
<u>Specific Facts</u>						
Tumbling	2/47	5.131	<.025	2/61	.853	--
Slide Projector	2/47	1.120	--	2/61	1.618	--
Shot Put	2/47	2.720	<.10	2/61	2.240	--
<u>Serial Ordering</u>						
Clay Beads	2/47	.630	--	2/61	1.284	--
Bird's Nest/Cartwheel	2/47	3.218	<.05	2/61	7.138	<.005
Motion Picture Projector	2/47	4.695	<.025	2/61	1.475	--
<u>Concepts</u>						
Gesture	2/47	4.880	<.025	2/61	1.159	--
Trampoline	2/47	.297	--	2/61	.264	--
Experimental Painting	2/47	.986	--	2/61	1.026	--
<u>SOCIAL STUDIES</u>						
<u>Specific Facts</u>						
Egypt Irrigation	2/45	3.399	<.05	2/56	10.118	<.001
African City	2/45	.957	--	2/56	3.300	<.05
Floating Market	2/45	2.635	<.10	2/56	8.231	<.001
<u>Serial Ordering</u>						
Banana Harvesting	2/45	19.755	<.001	2/56	3.191	<.10
Copra	2/45	2.358	--	2/56	.092	--
Lumbering	2/45	2.567	<.10	2/56	.963	--
<u>Concepts</u>						
African Village	2/45	3.506	<.05	2/56	5.052	<.025
East. Europe/Midd. Amer.	2/45	1.601	--	2/56	1.925	--
Transportation in India	2/45	.262	--	2/56	.771	--

TABLE 18
TOTAL PERFORMANCE TEST MEAN SCORES FOR HIGH AND LOW
MENTAL ABILITY GROUPS (FIFTH GRADE)

	High Verbal SCAT			Low Verbal SCAT		
	MP	Seq	Still	MP	Seq	Still
<u>SCIENCE</u>						
<u>Specific Facts</u>						
Nuclear Reactions	3.53	2.93	3.33	1.75	1.63	2.57
Cells	4.00	3.67	3.13	3.63	3.86	2.75
Contours	4.42	3.47	2.29	3.86	3.75	2.50
<u>Serial Ordering</u>						
Plants	5.33	2.07	2.08	6.08	1.50	1.86
Filtering	10.00	8.08	6.33	8.88	7.14	6.50
Tacoma Bridge	6.17	5.00	5.57	5.00	3.08	3.75
<u>Motor Skills</u>						
Steam	2.73	2.07	1.92	2.83	2.00	1.71
Dome & Volcanic Mts.	2.57	2.92	3.40	2.88	2.14	2.67
Amusement Park	1.83	2.47	1.86	2.57	2.25	2.63
<u>MOTOR SKILLS</u>						
<u>Specific Facts</u>						
Tumbling	14.94	13.33	13.86	13.00	12.25	11.86
Slide Projector	6.13	4.86	6.24	5.25	4.36	5.50
Shot Put	3.14	2.82	2.27	2.14	2.75	1.94
<u>Serial Ordering</u>						
Clay Beads	6.88	5.53	5.43	5.42	4.25	4.86
Bird's Nest/Cartwheel	6.60	4.07	4.94	4.00	4.07	3.92
Motion Picture Proj.	4.21	4.00	3.27	4.29	3.08	2.88
<u>Concepts</u>						
Gesture	5.29	5.00	4.64	4.33	4.06	3.50
Trampoline	6.93	6.64	6.71	6.38	6.57	6.67
Experimental Painting	2.14	1.88	1.93	2.14	1.58	2.19
<u>SOCIAL STUDIES</u>						
<u>Specific Facts</u>						
Egypt Irrigation	6.29	3.87	4.50	5.00	4.31	4.24
African City	8.00	7.21	7.14	7.62	7.88	7.75
Floating Market	8.36	7.43	7.33	8.65	7.50	6.69
<u>Serial Ordering</u>						
Banana Harvesting	7.00	3.27	2.40	6.25	3.62	3.82
Copra	4.60	4.07	4.00	6.08	3.29	3.92
Lumbering	7.71	6.14	5.73	6.82	5.00	6.15
<u>Concepts</u>						
African Village	9.33	7.80	8.36	7.08	6.85	6.00
East. Europe/Midd. Amer.	3.73	5.43	5.29	4.39	4.35	4.33
Transportation in India	6.79	7.10	7.20	6.06	6.17	6.00

TABLE 19
TOTAL PERFORMANCE TEST MEAN SCORES FOR HIGH AND LOW
MENTAL ABILITY GROUPS (SIXTH GRADE)

	High Verbal Lorge-Thorndike			Low Verbal Lorge-Thorndike		
	MP	Seq	Still	MP	Seq	Still
<u>SCIENCE</u>						
<u>Specific Facts</u>						
Nuclear Reactions	4.00	3.61	4.12	2.86	2.67	2.50
Cells	4.33	4.35	4.25	3.71	2.80	3.14
Contours	4.24	4.06	4.89	3.30	3.48	3.91
<u>Serial Ordering</u>						
Plants	7.13	3.44	2.82	3.48	2.91	2.10
Filtering	11.67	7.88	7.94	10.43	7.80	6.05
Tacoma Bridge	5.65	4.25	4.89	5.40	5.48	4.14
<u>Motor Skills</u>						
Steam	3.75	2.89	2.77	2.62	1.81	1.45
Dome & Volcanic Mts.	3.61	3.29	3.19	3.10	2.45	2.52
Amusement Park	2.41	2.63	2.56	2.10	1.71	2.19
<u>MOTOR SKILLS</u>						
<u>Specific Facts</u>						
Tumbling	15.47	13.13	14.06	12.77	12.05	13.05
Slide Projector	5.47	5.19	5.95	5.41	4.90	5.96
Shot Put	3.38	3.00	2.53	2.90	2.18	2.46
<u>Serial Ordering</u>						
Clay Beads	5.95	5.33	6.00	5.77	5.14	4.80
Bird's Nest/Cartwheel	6.13	3.50	5.11	5.55	3.00	5.23
Motion Picture Proj.	5.69	4.84	3.67	4.45	3.73	3.46
<u>Concepts</u>						
Gesture	6.05	4.13	4.38	4.46	4.64	3.90
Trampoline	7.00	7.25	7.42	6.18	6.55	6.46
Experimental Painting	1.88	2.42	2.13	2.20	1.73	1.77
<u>SOCIAL STUDIES</u>						
<u>Specific Facts</u>						
Egypt Irrigation	6.13	5.00	4.93	5.94	4.95	3.81
African City	7.83	7.60	8.27	7.75	7.29	8.39
Floating Market	9.27	7.80	7.72	9.10	7.33	7.20
<u>Serial Ordering</u>						
Banana Harvesting	7.47	4.56	3.27	6.17	4.75	4.38
Copra	5.72	5.13	4.60	4.85	4.62	4.72
Lumbering	8.07	6.93	6.39	6.91	7.17	6.05
<u>Concepts</u>						
African Village	9.40	8.11	8.00	8.72	7.50	6.95
East. Europe/Midd. Amer.	8.61	10.93	8.87	8.40	6.52	5.89
Transportation in India	7.27	7.07	7.44	6.86	7.06	6.40

APPENDIX D

TABLE 20

MEAN SCORES ON INDIVIDUAL TEST ITEMS SHOWING SIGNIFICANT DIFFERENCES ON ANALYSIS OF VARIANCE*

	Present- tation Mode	Fifth Grade				Sixth Grade			
		\bar{X}	df	F	Prob.	\bar{X}	df	F	Prob.
<u>SCIENCE</u>									
<u>Specific Facts</u>									
<u>Nuclear Reactions</u>									
#1e	MP**	.26	2/66	.411	--	.35	2/109	5.569	<.005
	Seq	.23				.26			
	St	.35				.61			
<u>Cells</u>									
#1	MP	.68	2/66	3.137	<.10	.64	2/109	1.574	<.25
	Seq	.45				.47			
	St	.33				.46			
<u>Contours</u>									
#1	MP	.40	2/66	2.649	<.10	.58	2/109	.299	--
	Seq	.70				.65			
	St	.46				.67			
#3	MP	.50	2/66	3.210	<.05	.44	2/109	1.753	<.25
	Seq	.19				.35			
	St	.46				.56			
#4	MP	.65	2/66	5.686	<.01	.19	2/109	3.750	<.05
	Seq	.26				.49			
	St	.25				.41			
#5a	MP	.80	2/66	1.613	<.25	.81	2/109	2.758	<.10
	Seq	.89				.87			
	St	.68				.97			
#5a	MP	.45	2/66	2.965	<.10	.25	2/109	.093	--
	Seq	.22				.22			
	St	.14				.26			

*Where a significant difference at less than .10 level exists in either grade, means are shown for both grades.

**MP = Motion Picture treatment; Seq = Sequenced treatment; St = Still Treatment.

TABLE 20--Continued

	Presenta- tion Mode	Fifth Grade				Sixth Grade			
		\bar{X}	df	F	Prob.	\bar{X}	df	F	Prob.
<u>Serial Ordering</u>									
<u>Plants</u>									
#1a	MP	.67	2/66	7.330	<.005	.60	2/109	7.991	<.001
	Seq	.23				.36			
	St	.25				.17			
#1b	MP	.96	2/66	26.139	<.001	.70	2/109	4.526	<.025
	Seq	.27				.51			
	St	.30				.36			
#1c	MP	.67	2/66	3.485	<.05	.62	2/109	3.183	<.05
	Seq	.32				.51			
	St	.40				.33			
#1d	MP	.70	2/66	3.114	<.10	.51	2/109	.805	--
	Seq	.50				.39			
	St	.35				.39			
#1e	MP	.70	2/66	8.892	<.001	.57	2/109	2.595	<.10
	Seq	.23				.44			
	St	.25				.31			
#2a	MP	.37	2/66	6.890	<.005	.51	2/109	10.058	<.001
	Seq	.05				.18			
	St	.05				.11			
#2b	MP	.48	2/66	6.522	<.005	.46	2/109	2.987	<.10
	Seq	.09				.36			
	St	.15				.19			
#2c	MP	.67	2/66	13.363	<.001	.60	2/109	5.034	<.01
	Seq	.14				.28			
	St	.15				.31			
#2a	MP	.44	2/66	8.060	<.001	.49	2/109	7.467	<.001
	Seq	.09				.10			
	St	.05				.31			
<u>Filtering</u>									
#1a	MP	.55	2/66	5.804	<.005	.54	2/109	6.457	<.005
	Seq	.15				.42			
	St	.19				.16			
#1b	MP	.41	2/66	2.192	<.25	.62	2/109	6.168	<.005
	Seq	.25				.28			
	St	.15				.30			

TABLE 20--Continued

	Presenta- tion Mode	Fifth Grade				Sixth Grade			
		\bar{X}	df	F	Prob.	\bar{X}	df	F	Prob.
#1c	MP Seq St	.59 .25 .19	2/66	5.502	<.01	.59 .33 .14	2/109	9.903	<.001
#1d	MP Seq St	.77 .60 .26	2/66	8.027	<.001	.87 .44 .30	2/109	17.664	<.001
#1e	MP Seq St	.40 .30 .07	2/66	4.184	<.025	.51 .17 .16	2/109	8.508	<.001
#2b	MP Seq St	.73 .50 .63	2/66	1.144	<.25	.87 .61 .62	2/109	4.184	<.025
#2c	MP Seq St	.50 .60 .52	2/66	.230	--	.77 .64 .38	2/109	6.805	<.005
#2d	MP Seq St	.55 .45 .30	2/66	1.600	<.25	.77 .47 .46	2/109	5.093	<.01
#2e	MP Seq St	.77 .70 .52	2/66	1.890	<.25	.80 .56 .62	2/109	2.632	<.10
#2f	MP Seq St	.55 .55 .33	2/66	1.519	<.25	.74 .50 .32	2/109	7.496	<.001
#4c	MP Seq St	.73 .50 .48	2/66	1.746	<.25	.77 .56 .49	2/109	2.881	<.10
<u>Tacoma Bridge</u>									
#2b	MP Seq St	.85 .48 .73	2/66	4.058	<.025	.75 .78 .67	2/109	.697	--
#4b	MP Seq St	.50 .37 .32	2/66	.751	--	.58 .27 .31	2/109	4.780	<.025
#4d	MP Seq St	.40 .56 .41	2/66	.736	--	.64 .35 .44	2/109	3.295	<.05

TABLE 20--Continued

	Present- ation Mode	Fifth Grade				Sixth Grade			
		\bar{X}	df	F	Prob.	\bar{X}	df	F	Prob.
<u>Concepts</u>									
<u>Steam</u>									
#1	MP Seq St	.85 .32 .25	2/60	14.705	<.001	.87 .36 .33	2/109	17.056	<.001
#4	MP Seq St	.41 .27 .25	2/66	.797	--	.48 .31 .19	2/109	3.730	<.05
<u>Dome & Vol. Mts.</u>									
#2	MP Seq St	.64 .95 .82	2/66	3.407	<.05	.85 .81 .68	2/109	1.725	<.25
#3	MP Seq St	.64 .50 .78	2/66	2.000	<.25	.67 .39 .57	2/109	3.053	<.10
#5	MP Seq St	.68 .60 .59	2/66	.229	--	.82 .81 .60	2/109	3.194	<.05
<u>Amusement Park</u>									
#3a	MP Seq St	.30 .50 .59	2/66	2.032	<.25	.50 .51 .72	2/109	2.369	<.10
<u>MOTOR SKILLS</u>									
<u>Specific Facts</u>									
<u>Tumbling</u>									
#1b	MP Seq St	.96 .71 .75	2/84	3.589	<.05	.95 .95 .86	2/112	1.337	--
#1c	MP Seq St	.96 .77 .75	2/84	2.817	<.10	.71 .57 .81	2/112	2.540	<.10
#1d	MP Seq St	.87 .87 1.00	2/84	2.644	<.10	.83 .92 .97	2/112	2.258	<.25
#1e	MP Seq St	.89 .58 .68	2/84	3.811	<.05	.79 .87 .75	2/112	.785	--

TABLE 20--Continued

	Presentation Mode	Fifth Grade				Sixth Grade			
		\bar{X}	df	F	Prob.	\bar{X}	df	F	Prob.
#5c	MP Seq St	.71 .77 .54	2/84	2.067	<.25	.83 .54 .64	2/112	4.243	<.025
#5d	MP Seq St	.86 .87 .86	2/84	.015	--	.98 .84 .86	2/112	2.385	<.10
#8	MP Seq St	.18 .55 .43	2/84	4.666	<.025	.36 .27 .22	2/112	.890	--
<u>Slide Projector</u>									
#3a	MP Seq St	.42 .25 .79	2/84	10.100	<.001	.35 .39 .69	2/112	5.966	<.005
#3b	MP Seq St	.65 .36 .82	2/84	7.337	<.005	.49 .50 .69	2/112	2.143	<.25
#4a	MP Seq St	.61 .43 .61	2/84	1.260	--	.81 .50 .41	2/112	7.828	<.001
#4b	MP Seq St	.84 .61 .89	2/84	4.029	<.025	.78 .81 .93	2/112	1.859	<.25
#4c	MP Seq St	.90 .82 .75	2/84	1.208	--	.92 .75 .93	2/112	3.421	<.05
<u>Shot Put</u>									
#1	MP Seq St	.46 .86 .58	2/84	5.358	<.01	.75 .60 .73	2/112	1.307	--
#3	MP Seq St	.57 .79 .52	2/84	2.543	<.10	.67 .62 .62	2/112	.112	--
#4	MP Seq St	.36 .21 .03	2/84	5.436	<.01	.25 .21 .14	2/112	.785	--
#5	MP Seq St	.79 .57 .68	2/84	1.472	<.25	.83 .64 .60	2/112	2.778	<.10

TABLE 20 --Continued

	Present- ation Mode	Fifth Grade				Sixth Grade			
		\bar{X}	df	F	Prob.	\bar{X}	df	F	Prob.
<u>Serial Ordering</u>									
<u>Clay Beads</u>									
#1a	MP	.71	2/84	2.968	<.10	.69	2/112	1.092	--
	Seq	.68				.60			
	St	.43				.53			
#1b	MP	.79	2/84	3.417	<.05	.76	2/112	1.872	<.25
	Seq	.68				.65			
	St	.46				.56			
#1c	MP	.89	2/84	3.626	<.05	.98	2/112	3.756	<.05
	Seq	.87				.87			
	St	.64				.78			
#1d	MP	.93	2/84	3.543	<.05	.91	2/112	1.525	<.25
	Seq	.87				.89			
	St	.68				.78			
#2a	MP	.82	2/84	2.269	<.25	.95	2/112	7.387	<.001
	Seq	.77				.70			
	St	.96				.94			
#2b	MP	.64	2/84	6.603	<.005	.48	2/112	.239	--
	Seq	.26				.51			
	St	.64				.56			
#2d	MP	.75	2/84	9.526	<.001	.62	2/112	.053	--
	Seq	.26				.60			
	St	.64				.58			
<u>Bird's Nest/Cart.</u>									
#1d	MP	.97	2/84	5.615	<.01	.97	2/114	3.013	<.10
	Seq	.68				.92			
	St	.89				.81			
#2a	MP	.55	2/84	1.881	<.25	.54	2/114	7.991	<.001
	Seq	.32				.14			
	St	.54				.48			
#2b	MP	.61	2/84	2.023	<.25	.57	2/114	6.812	<.005
	Seq	.36				.19			
	St	.54				.52			
#2c	MP	.61	2/84	2.023	<.25	.60	2/114	7.491	<.001
	Seq	.36				.19			
	St	.54				.52			

TABLE 20--Continued

	Presenta- tion Mode	Fifth Grade				Sixth Grade			
		\bar{X}	df	F	Prob.	\bar{X}	df	F	Prob.
#2d	MP	.48	2/84	.260	--	.51	2/114	3.744	<.05
	Seq	.46				.22			
	St	.39				.45			
#2e	MP	.42	2/84	.305	--	.32	2/114	4.570	<.025
	Seq	.32				.08			
	St	.36				.36			
#2f	MP	.45	2/84	.273	--	.49	2/114	6.329	<.005
	Seq	.36				.14			
	St	.39				.45			
<u>Motion Pic. Proj.</u>									
#1c	MP	.86	2/84	3.749	<.05	.83	2/114	8.132	<.001
	Seq	.75				.79			
	St	.55				.46			
#1d	MP	.89	2/84	3.789	<.05	.89	2/114	7.185	<.005
	Seq	.71				.81			
	St	.58				.54			
#2b	MP	.54	2/84	5.032	<.01	.67	2/114	2.313	<.25
	Seq	.32				.48			
	St	.16				.43			
#2c	MP	.46	2/84	3.988	<.025	.68	2/114	3.186	<.05
	Seq	.21				.41			
	St	.16				.43			
<u>Concepts</u>									
<u>Gesture</u>									
#1a	MP	.82	2/84	4.259	<.025	.71	2/114	1.817	<.25
	Seq	.68				.54			
	St	.46				.53			
#1c	MP	.43	2/84	.219	--	.64	2/112	5.079	<.01
	Seq	.36				.30			
	St	.43				.44			
#1f	MP	.50	2/84	.415	--	.62	2/112	2.349	<.10
	Seq	.55				.41			
	St	.43				.41			
#3	MP	.68	2/84	1.070	--	.79	2/112	2.412	<.10
	Seq	.71				.65			
	St	.54				.56			

TABLE 20--Continued

	Present- ation Mode	Fifth Grade				Sixth Grade			
		\bar{X}	df	F	Prob.	\bar{X}	df	F	Prob.
<u>Trampoline</u>									
#1	MP	.58	2/84	1.530	<.25	.41	2/112	3.654	<.05
	Seq	.75				.67			
	St	.54				.67			
#2	MP	.74	2/84	.140	--	.54	2/112	2.982	<.10
	Seq	.68				.81			
	St	.71				.64			
#4	MP	.55	2/84	.350	--	.84	2/112	4.623	<.025
	Seq	.57				.67			
	St	.46				.52			
<u>Experiment. Paint.</u>									
#3a	MP	.36	2/84	3.483	<.05	.33	2/112	.209	--
	Seq	.14				.41			
	St	.45				.38			
<u>SOCIAL STUDIES</u>									
<u>Specific Facts</u>									
<u>Egypt Irrigation</u>									
#1a	MP	.85	2/89	3.060	<.10	.94	2/104	4.344	<.025
	Seq	.57				.66			
	St	.74				.75			
#1b	MP	.97	2/89	7.972	<.001	.94	2/104	21.665	<.001
	Seq	.86				.95			
	St	.61				.47			
#1c	MP	.91	2/89	7.035	<.005	.82	2/104	3.034	<.10
	Seq	.61				.79			
	St	.52				.58			
#1d	MP	.91	2/89	14.999	<.001	.97	2/104	10.209	<.001
	Seq	.32				.53			
	St	.68				.64			
#2	MP	.79	2/89	3.682	<.05	.94	2/104	2.663	<.10
	Seq	.46				.74			
	St	.58				.78			
#4	MP	.88	2/89	.103	--	.91	2/104	3.660	<.05
	Seq	.86				.92			
	St	.84				.72			

TABLE 20 --Continued

	Present- tation Mode	Fifth Grade				Sixth Grade			
		\bar{X}	df	F	Prob.	\bar{X}	df	F	Prob.
<u>African City</u>									
#2b	MP	.64	2/89	3.144	<.05	.87	2/104	7.757	<.001
	Seq	.39				.47			
	St	.67				.73			
#2c	MP	.96	2/89	4.872	<.025	.92	2/104	.346	--
	Seq	.84				.86			
	St	.67				.88			
#3a	MP	1.00	2/89	3.441	<.05	.92	2/104	1.225	--
	Seq	.94				.83			
	St	.82				.94			
#3c	MP	.71	2/89	.982	--	.53	2/104	4.484	<.025
	Seq	.84				.69			
	St	.70				.85			
#3d	MP	.14	2/89	4.500	<.025	.32	2/104	11.752	<.001
	Seq	.42				.33			
	St	.49				.79			
<u>Floating Market</u>									
#1a	MP	.81	2/89	4.753	<.025	.86	2/104	5.436	<.01
	Seq	.46				.52			
	St	.54				.61			
#1b	MP	.42	2/89	2.189	<.25	.67	2/104	11.919	<.001
	Seq	.21				.24			
	St	.21				.21			
#1c	MP	1.00	2/89	3.436	<.05	.97	2/104	1.037	--
	Seq	.85				.91			
	St	.96				.97			
#3b	MP	.90	2/89	.232	--	.94	2/104	3.602	<.05
	Seq	.85				.82			
	St	.86				.71			
#4a	MP	.68	2/89	2.333	<.25	.86	2/104	5.170	<.01
	Seq	.46				.52			
	St	.43				.68			
#4b	MP	.94	2/89	2.575	<.10	.97	2/104	6.691	<.005
	Seq	.82				.70			
	St	.71				.66			

x

TABLE 20--Continued

	Presentation Mode	Fifth Grade				Sixth Grade			
		\bar{X}	df	F	Prob.	\bar{X}	df	F	Prob.
<u>Serial Ordering</u>									
<u>Banana Harvesting</u>									
#1a	MP	.52	2/89	12.784	<.001	.67	2/104	14.607	<.001
	Seq	.04				.21			
	St	.16				.17			
#1b	MP	.67	2/89	21.088	<.001	.70	2/104	12.154	<.001
	Seq	.04				.18			
	St	.23				.33			
#1c	MP	.67	2/89	6.577	<.005	.76	2/104	9.054	<.001
	Seq	.36				.29			
	St	.26				.44			
#2a	MP	.76	2/89	4.198	<.025	.82	2/104	12.230	<.001
	Seq	.43				.74			
	St	.48				.33			
#2b	MP	.79	2/89	9.408	<.001	.76	2/104	8.506	<.001
	Seq	.32				.74			
	St	.39				.36			
#2c	MP	.79	2/89	3.289	<.05	.61	2/104	.395	--
	Seq	.50				.50			
	St	.55				.56			
#2d	MP	.76	2/89	2.521	<.10	.61	2/104	1.003	--
	Seq	.50				.48			
	St	.55				.44			
#2e	MP	.91	2/89	3.288	<.05	.94	2/104	4.633	<.025
	Seq	.64				.86			
	St	.74				.67			
#2f	MP	.88	2/89	6.497	<.005	.98	2/104	4.393	<.025
	Seq	.61				.68			
	St	.48				.61			
<u>Copra</u>									
#1b	MP	.71	2/89	2.741	<.10	.58	2/104	.029	--
	Seq	.45				.58			
	St	.46				.61			
#2a	MP	.77	2/89	5.452	<.01	.82	2/104	1.630	<.25
	Seq	.39				.64			
	St	.64				.67			

TABLE 20--Continued

	Present- ation Mode	Fifth Grade				Sixth Grade			
		\bar{X}	df	F	Prob.	\bar{X}	df	F	Prob.
#2b	MP Seq St	.96 .74 .79	2/89	2.876	<.10	1.00 .86 .97	2/104	3.828	<.025
<u>Lumbering</u>									
#2a	MP Seq St	.84 .58 .61	2/89	3.079	<.10	.78 .55 .53	2/104	3.075	<.05
#2c	MP Seq St	.94 .67 .68	2/89	4.149	<.025	.78 .70 .53	2/104	2.804	<.10
#2d	MP Seq St	.94 .76 .82	2/89	1.906	<.25	.94 .79 .95	2/104	3.190	<.05
#3b	MP Seq St	.68 .49 .46	2/89	1.711	<.25	.64 .49 .37	2/104	2.780	<.10
#3d	MP Seq St	.36 .33 .36	2/89	.023	--	.42 .39 .18	2/104	2.821	<.10
<u>Concepts</u>									
<u>African Village</u>									
#1	MP Seq St	.64 .46 .36	2/89	2.649	<.10	.58 .37 .61	2/104	2.595	<.10
#3c	MP Seq St	.70 .75 .74	2/89	.126	--	.88 .66 .72	2/104	2.418	<.10
#4	MP Seq St	.88 .25 .16	2/89	33.549	<.001	.97 .42 .11	2/104	48.803	<.001
#5e	MP Seq St	.70 .75 .77	2/89	.252	--	.88 .79 .61	2/104	3.665	<.05
<u>East.Eur/Mid.Amer</u>									
#3e	MP Seq St	.21 .42 .39	2/89	1.609	<.25	.68 .58 .39	2/104	3.173	<.05

TABLE 20--Continued

	Presenta- tion Mode	Fifth Grade				Sixth Grade			
		\bar{X}	df	F	Prob.	\bar{X}	df	F	Prob.
<u>Transp. in India</u>									
#1	MP	.55	2/89	.876	---	.67	2/104	2.752	<.10
	Seq	.70				.79			
	St	.68				.53			
#2	MP	.68	2/89	.235	---	.58	2/104	3.343	<.05
	Seq	.61				.76			
	St	.68				.84			
#7	MP	1.00	2/89	2.169	<.25	1.00	2/104	2.438	<.10
	Seq	.97				.88			
	St	.89				.95			