

ED 025 119

EF 002 314

Heating, Ventilation, Air Conditioning. Resource Manual for Custodial Training Course #3.
Florida State Dept. of Education, Tallahassee. School Plant Management Section.
Pub Date Sep 65

Note- 143p.

EDRS Price MF-\$0.75 HC-\$7.25

Descriptors- *Air Conditioning, Climate Control, *Custodian Training, Equipment Maintenance, Guidelines,
*Heating, Instructional Materials, Manuals, Mechanical Equipment, *Resource Guides, School Maintenance,
Thermal Environment, *Ventilation

Intended as a manual to provide school custodians with some understanding of basic functions of heating, ventilating, and air conditioning equipment for safe, efficient operation. Contains general rules and specifications for providing custodians with a more complete awareness of their equipment and the field of "Climate Control" within the school. Chapters include--(1) What is Heat? Cold? Energy?, (2) Factors Determining Health and Comfort, (3) Heating Systems, (4) Heat Generators, (5) Fuels and Combustion, (6) Daily Procedures for Heating Devices, (7) Boiler Care, (8) Ventilation, (9) Air Conditioning, (10) Control Systems, and (11) Heat Pumps. A brief history of heating and a comprehensive glossary are also included. (RH)

HEATING, VENTILATION, AND AIR CONDITIONING

ED025119



RESOURCE MANUAL



CUSTODIAL TRAINING COURSE

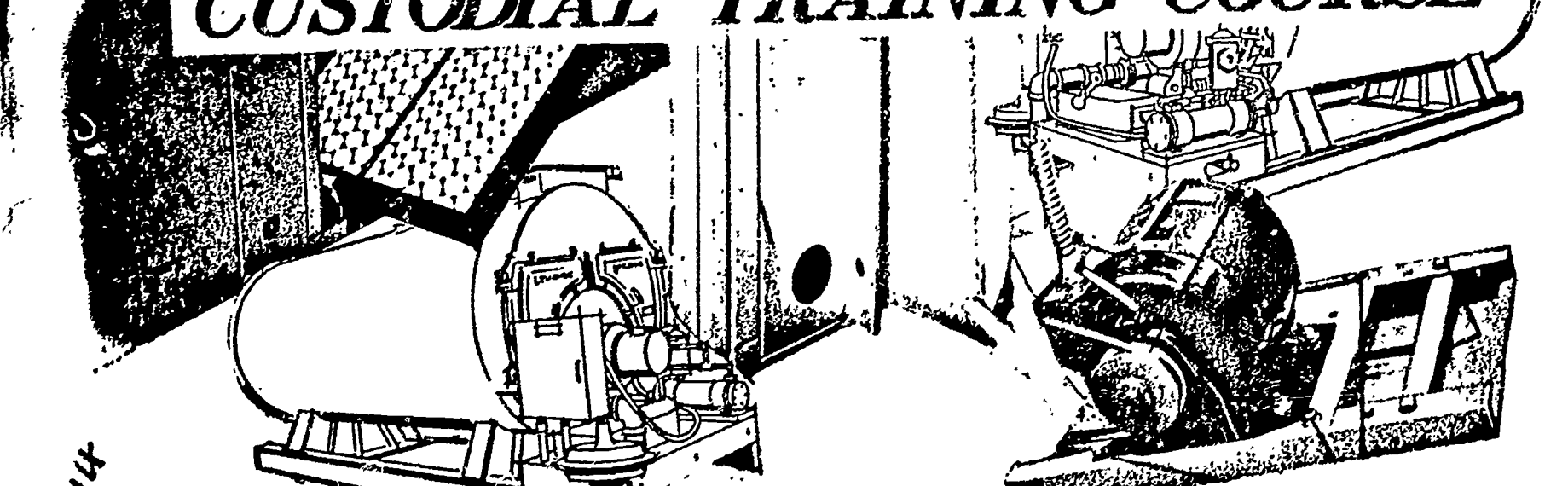

STATE DEPARTMENT OF EDUCATION
FLOYD T. CHRISTIAN, SUPERINTENDENT
TALLAHASSEE, FLORIDA

EF002314

U.S. DEPARTMENT OF HEALTH, EDUCATION & WELFARE
OFFICE OF EDUCATION

THIS DOCUMENT HAS BEEN REPRODUCED EXACTLY AS RECEIVED FROM THE
PERSON OR ORGANIZATION ORIGINATING IT. POINTS OF VIEW OR OPINIONS
STATED DO NOT NECESSARILY REPRESENT OFFICIAL OFFICE OF EDUCATION
POSITION OR POLICY.

RESOURCE MANUAL

for

CUSTODIAL TRAINING COURSE #3

**HEATING
VENTILATION
AIR CONDITIONING**

ED025119

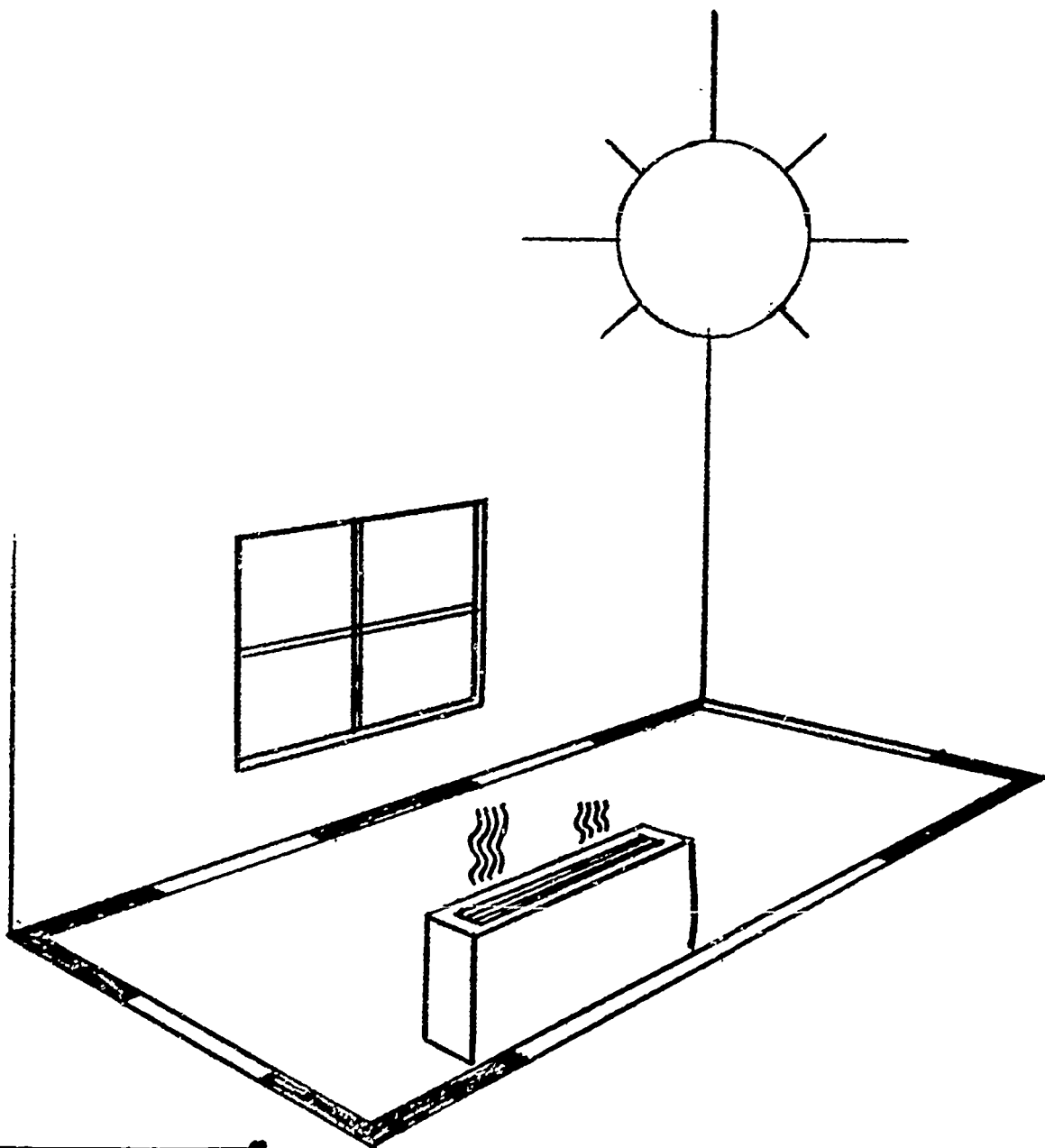
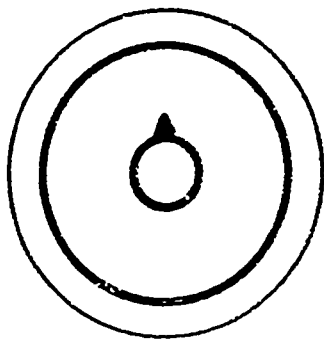

Prepared by:

School Plant Management
State Department of
Education
Tallahassee, Florida

Additional copies may be obtained by writing to:

School Plant Management Section:
State Department of Education
Tallahassee, Florida

September, 1965

FOREWORD

Modern concepts of air-conditioning embrace the functions of air heating, air cooling, humidity control, and air distribution. Distribution in turn implies the delivery of fresh air and the removal of used air. These functions in a school environment are important in achieving student and staff comfort, efficiency and health.

Each school building should be designed so that the atmosphere of the interior is kept at healthful levels of temperature and humidity, and drafts are avoided. Proper heating, cooling, and distribution of air are conducive to pupil and staff comfort and efficiency and are a deterrent to upper respiratory infections.

The most carefully designed and manufactured air tempering system is of little value if the person who is to operate it does not understand the basic functions, and the proper operation and care of the system. Lack of knowledge of the proper operation, recognition of danger symptoms, and improper maintenance can permit situations to develop which can be harmful to the equipment as well as to the occupants.

It is hoped that this course, designed for school custodians will provide some understanding of the basic functions of heating, ventilating, and cooling equipment, as well as general rules for safe, efficient operation. With so many manufacturers, models, and modifications, it would not be practical to attempt to cover specific details for each piece of equipment available. The general rules contained in this manual are intended to give the school custodian a greater understanding of his equipment and the field of "climate control" within the school.

ACKNOWLEDGMENTS

The materials in this manual were prepared by Mr. Walter E. Kowall, Coordinator of Custodial and Maintenance Training, with the assistance and advice of Mr. Nelson E. Viles, Jr., Consultant, School Plant Management and Insurance, and Mr. Luther S. Smith, for his original research and format. Information came from many sources including the literature in the field and experience gained while working in the school districts.

Appreciation is extended to the many members of the Florida School Plant Management Association, and to Mr. Paul Stanley, Polk County School System. Special recognition is given to the following companies for their assistance:

Airtherm Manufacturing Company

American Standard

Calgon Corporation

Hoffman Specialty Manufacturing Corporation

Kritzer Radiant Coils, Inc.

McMillan Comfortaire, Inc.

Minneapolis-Honeywell Regulator Company

Peerless Heater Company

Titusville Iron Works

Weil-McLain Company, Inc.

Particular appreciation is extended to Mr. C. W. Nessell, for permission to use excerpts from his article on the, "History of Heating". We also wish to express our appreciation to the University of Nebraska Press for permission to use material in "Handbook for School Custodians", Fifth Edition, by Mr. Alanson D. Brainard as revised by Mr. A. E. Goedeken.

TABLE OF CONTENTS

FOREWORD	1
ACKNOWLEDGMENTS	iii
INTRODUCTION -- HISTORY OF HEATING	1
 <u>CHAPTER</u>	
I General	
What is heat? Cold? Energy? Energy transfer?	
Energy equivalents; definitions	17
II Factors Determining Health and Comfort	
Temperature, humidity, odor control, air movement,	
dust, noise, activity, etc.	33
III Heating Systems	
Advantages and disadvantages of six types of systems. .	41
IV Heat Generators	
Classification of steam systems; Boiler parts and	
their uses; Care of the boiler	53
V Fuels and Combustion	
Gas - natural and manufactured; Fuel oils;	
Theory of combustion; Burners; Controls	69
VI Daily Procedures for Heating Devices	
Pre-start procedures; Blowdown; Locating boiler	
trouble; Things to remember when operating a boiler;	
Economies in heating	85

CHAPTER

VII Boiler Care

Cleaning; Tube and flue care; Flue gas analysis;
Electrolysis; Boiler compounds; Preparing for
summer lay-up - wet or dry method 97

VIII Ventilation

Methods; Rates of air movement 113

IX Air-Conditioning

General problems to be overcome; Unit air-conditioners;
Central air-conditioning - components and controls . . . 123

X Controls for Heating, Ventilating, and Air-Conditioning

Systems

Fundamentals, definitions; Control areas 137

XI Heat Pumps

Definitions, basic circuits; Types 145

THE HISTORY OF HEATING

The history of heating starts with prehistoric man kindling a fire in his cave. He had no chimney, so he rushed outdoors occasionally to clear his lungs of smoke.

The first thing he learned about fire was that it gave heat, and heat could make his food more palatable and his body more comfortable. Little good it did him though because early man did not know how to start a fire when he wanted one. He could hardly adjust his need for a fire to the eruption of a volcano or for lightning to set near-by woods ablaze.

Finally man discovered he could start a fire when he wanted one by rubbing two dry sticks together long enough. There were several varieties of this method.

Perhaps the most interesting one was the fire saw. A piece of dry bamboo was split and filled with tinder. Another section of bamboo was sharpened along one edge and used as a saw to cut through the first. Hot sawdust dropping on the tinder set it afire. One day someone hit a pyrite stone with a bit of flint. Sparks resulted, and man discovered that if he caught the spark in a bit of dry tinder he had a fire.

Since none of these fire-kindling methods was very fast and most of them uncertain, a fire once started was carefully hoarded. Almost every village had a communal fire, and fire-tenders watched over them.

Eventually perpetual fires also were maintained in almost every dwelling, and when such was the case the women of the home were given the responsibility of "keeping the home fires burning". All this was changed, however, when the first practical friction match appeared in

1827. These were known as Jones Lucifers.

Probably the messiest and most dangerous match appeared shortly after 1800. Wooden splints tipped with a mixture of potassium chlorate and sugar was ignited by dipping it into a bottle of sulphuric acid.

These were sold at 50 matches, including the bottle of acid, for two dollars.

The "Jones Lucifer" was an obnoxious but practical match. It was a wood splint tipped with a chemical containing antimony sulphide and was ignited by drawing it through the folds of a special paper furnished with the match box.

After man discovered how he could start a fire when he wanted one, he was confronted with the problem of what to do with it after he had it started. Fire always is accompanied by heat and smoke. Man wanted the heat but did not care for the smoke, but he had no way to keep the one and discard the other. So for awhile he had both. Chimneys were not used until early in the 15th century. They proved much more efficient than a hole in the roof.

The tepee of the American Indian was a good example of this. It had an opening at the top through which the smoke could escape.

The Romans took the lead in heating techniques and had a heating system in more pretentious buildings that was not unlike some heating methods used today. The ordinary method of heating a room in a Roman house was by open fire pans or braziers in the center of the room. Wood and charcoal were the most common fuels. Imported woods were used for special occasions. The wood was soaked in water and then dried and perfume added.

The average British family in the ancient days has one place for

a fire, and that was a hole in the center of the floor. Later a regular hearth was constructed in the same location and still later the hearth was moved to one side of the room.

Early Persians had a unique method of warming their buildings. They provided an opening in the floor in the center of the room and sunk an iron stove in the earth beneath it.

The most advanced method of heating in those days and for centuries to follow was the Roman Hypocaust, which was a form of floor panel radiant heating. The area of the building to be heated was erected over a series of flues or heating chambers directly under the floor. The furnace was a large circular or rectangular room with suitable arrangements for burning the fuel, usually wood. The hot products of combustion flowed into the underfloor heating chamber and then up a series of flues on the inside surfaces of the walls.

Heating by the underfloor method was usually confined to the sleeping quarters and to the baths, the latter being the favored rooms of the Romans. This method of heating was only for the rich, and his less favored brothers continued to use the open fire in the room.

In England and in some of the colder climates of Europe there was much sickness and the prevalence of "consumption" or tuberculosis gave rise to much concern. Most of these ills, it was asserted, was the result of inadequate and uneven heating of the home.

When chimneys were invented, man made his first breakthrough in separating heat from smoke. It was a step forward but much still remained to be done. While he was able with the chimney to separate smoke from heat, less than 20 per cent of the heat was used.

No one knows who invented chimneys nor precisely when they first

appeared. There is some evidence that the remains of a chimney were found in an English castle built in the 12th century.

With the coming of the chimney, also came the fireplace. This was the principle method of heating for many years, not only in Europe, but also in America. Wood and charcoal were the universal fuels through the 16th and early 17th centuries. The fireplaces were inclined to smoke badly because of poor chimney design, particularly if there was a lack of combustion air. This, in turn, was responsible for heavy soot deposits on the inner passages of the chimney flues. They had to be cleaned occasionally and thus was born the new trade of "chimney sweeps".

Drafts of chilly air whipped across the floor and through the room en route to the fireplace, chilling the backs of those seated in front of the fire while the heat from the fire baked the front of them.

Although a number of improvements had been made in the fire place over the years, it still remained an unsatisfactory method of heating. Its successor was the stove. The early history of stoves is a bit cloudy. The ancient Chinese had one made of brick. It retained heat long after the fire had become a bed of embers, so it was used to heat the rooms during the day and the top of it served as a warm bed at night.

Some old stoves heated two rooms instead of one. They were built through a partition, with half in the living area and the other side in the kitchen or servants' quarters where the firing was done. The stove as we know it today started in the fireplace opening with the front end projecting out a short distance into the room. The smoke, after passing through a modified type of diverting flue, entered into

the fireplace chimney. Soon it was redesigned as a free standing stove connected to the chimney with a smokepipe and the front enclosed with doors. Box stoves were the prototype of the modern stove. They were just what their name implies a box-shaped stove made with cast iron sides, top and bottom. There was a fire door in front and a smoke pipe connection at the back. The early stoves were not very efficient because they lacked heating surface, so the stove designers increased the heating surface by using unique and ornamental designs. One model of the box stove was known as the "Four O'Clock Stove". It was a small model that was designed for heating a bedroom. The fire was started about 4 p.m. to take the chill out of the bedroom.

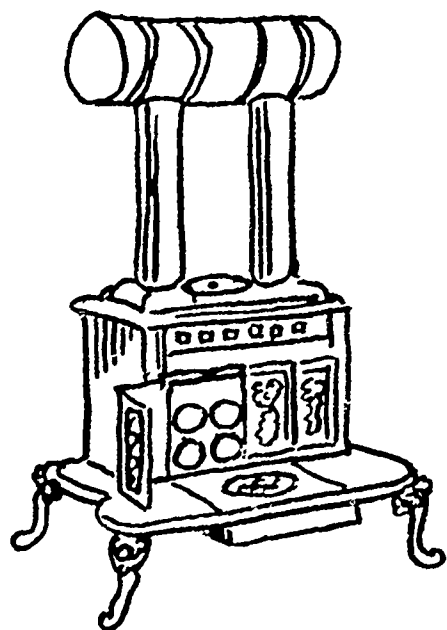
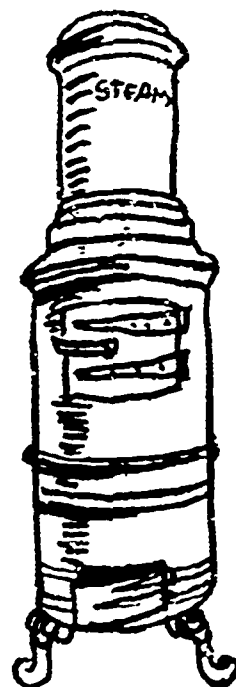

Later in the 18th century came the Cannon stoves, so called because they were round instead of square. They were used to heat meeting halls, churches and court rooms. During this time the use of wood was giving way to anthracite coal. A result was the good old Baseburner with illuminated front and sides.

One feature of a Baseburner was that a sufficient supply of coal could be placed to last an entire day. The front and sides had windows covered with mica so the burning coals cast a ruddy glow. The coal was stored in a magazine and the coals burned around the base of the magazine. That was

good in theory but improper design and venting of the magazine resulted in accumulation of gas. The explosions which resulted were somewhat disconcerting to the home owner.

A number of other stoves should be mentioned. One is the Air-tight stove, introduced about the middle of the 19th century and widely used until the early 1900's. They had two doors, one at the base of the stove for removing the ashes (they had no grates, the fire burning directly on the cast-iron base) and one higher up in the front for tossing in the wood.

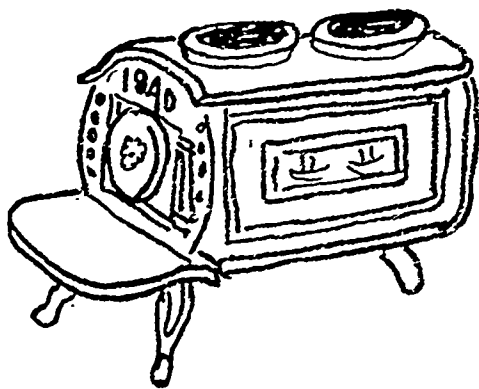
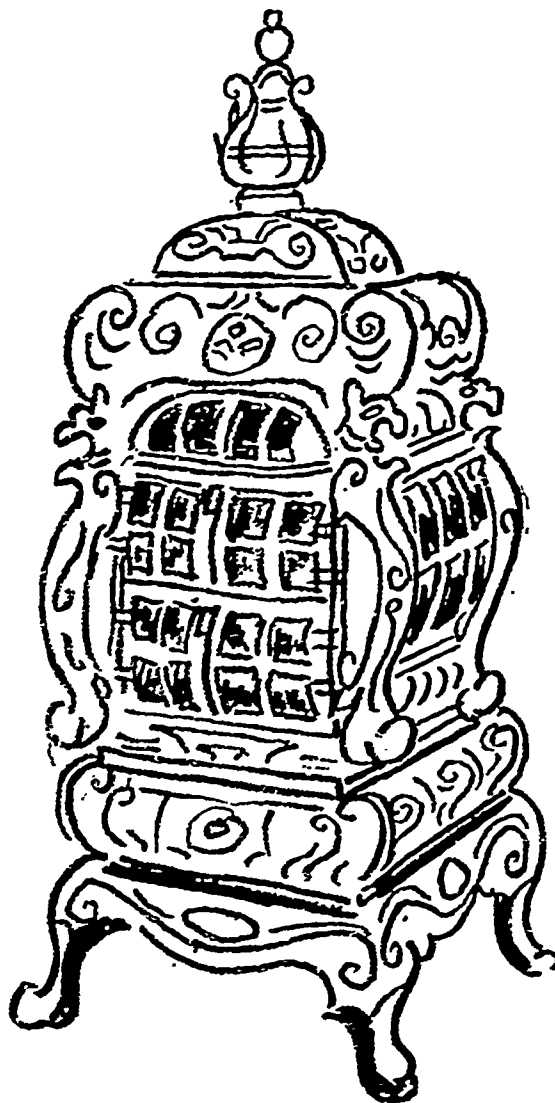

We usually think of a horse as a "hay-burner" but there were stoves especially designed for burning hay. It had a rather unusual construction and shape and the hay was introduced into it in tightly wound rolls through a couple of tubes leading into the firebox. In the west, stoves were adapted to burn buffalo chips, corn cobs, and in the Northwest one that would burn sawdust.

Replacing the stove with a central heating system brought about many big changes in family living, as well as in the architectural

arrangements of the house and the furnishings used. The central system took that dirt out of the living area and placed it in the cellar. Better furnishings, finer fabrics, lighter and brighter decor followed. At best the stove never was a thing of beauty.

Also gone is an element of family life that resulted because the stove could heat only one room well. The old parlor stove usually was placed in the "settin' room" and since that was the only comfortable room in the house, that was where the family gathered after supper dishes were done, and played games, told stories or read until time to retire.

Just when central heating systems first appeared is not quite clear, nor is it clear whether the first such systems were warm air or steam. Steam heating did not come into general use until about the beginning of the 19th century. On the other hand, the stove was used to heat most homes, along with the fireplace, during the 18th century, and the word "stove" was rather loosely used with respect to its use.

Hot water central heating systems were developed during the early part of the 19th century and came into general use about the middle of that century. The forward march to better heating started in earnest during the first half of the 19th century. By the middle of the 19th century much of the problems had been overcome, and central heating systems appeared in more homes as well as public buildings.

The first warm-air heating system using a furnace appeared in England about 1792. It was described as one using a "Cockle stove" and a system of pipes and flues to heat a large cotton factory. The Cockle stove today would be called a heat exchanger, direct fired. The Cockle stove

was made of cast iron and constructed with thick and heavy walls - top, bottom and sides, or in other words a cast-iron case to enclose the fire. This case was called the cockle, and in turn it was enclosed in a brick casing with a minimum of 3 or 4 inches between the inside surface of the casing and the cockle or heat exchanger, to provide air circulation. Openings at the bottom of the brick enclosure allowed cold air to enter. The heated air was conveyed in pipes and flues in to rooms to be heated from the top of the enclosure.

The early warm air furnaces came in for much criticism of a sort that unfortunately continued into the 20th century. The heating surfaces of the stoves or heat exchangers within the furnace assembly became very hot - 1,000 degrees or more. It was claimed that when air passed over such high temperature surfaces, it deteriorated and was not fit to breathe. Heating engineers went to work and came up with a solution that heating engineers of a more recent era have rediscovered. The cast-iron case of the Cockle stove, which received heat from the fire, was covered with cast-iron ribs projecting three or four inches from the surface. These ribs increased the heating surface and thereby reduced the temperature of it.

The first warm air furnace along present day lines manufactured in the United States, it is believed, was in Worcester, Massachusetts, in 1835. This was the start of a new industry in the country and it expanded rapidly. By 1850 there were a number of them producing furnaces. The industry grew rapidly between 1850 and 1900, but the mortality rate of manufacturers was high. Along with the increase in the number of manufacturers came new designs and some of them bordered on the fantastic. One novelty in furnace design was the "combination heater"

that could heat part of the house with warm air and the rest with either steam or hot water. The lower sections of these furnaces were not much different from a straight warm air furnace, but interspersed within the combustion chamber and the radiator was a small boiler. It was a most complex-looking affair.

The principal requirement of a mechanic installing these furnaces was that of a strong back. They were made of cast-iron and the manufacturer did not spare the iron. Some of these furnaces for an average sized house of that day weigh as much as 1,500 to 2,000 pounds and some of the individual sections, particularly the radiators, 400 to 500 pounds.

Furnaces were rated by diameter of the fire pot and the cubic feet of space it would heat. The rated capacity in cubic feet was arrived at by a guess and by-gosh method and the rated capacity for identical furnaces made by different manufacturers would vary widely. No one knew how to design or install a good warm air heating system, and for a while it seemed that no one cared. Manufacturers engaged in a price war. The construction of the furnace was downgraded and dozens of manufacturers went broke. As a result, warm air heating had a dismal reputation along about 1900 and it was evident that something had to be done.

In 1906 the Federal Furnace League was organized with these objectives:

1. To supply the home abundantly and properly with fresh air.
2. That to do this and elevate warm-air heating to the position it rightfully deserved required a concerted effort toward education of the dealer.

Not announced but a part of the plan was to use a uniform method of arriving at the capacity ratings of gravity warm-air furnaces.

The seed for associations had been planted. As a result the National Heating and Ventilating Association was formed in 1914. The name was changed to National Warm Air Heating and Ventilating Association and still later to the National Warm Air Heating and Air Conditioning Association and it is still operating under that name.

Meanwhile, use of steel instead of cast-iron in the manufacture of furnaces had been increasing. Eventually a number of manufacturers announced steel furnaces and that started a trend away from cast-iron to steel construction.

The pipeless furnace era was one that did the furnace heating and industry no good. Almost from the beginning, a separate warm air pipe or duct was brought to each room in the house to be heated. However, about 1916 a new type of furnace was marketed. Advertisements claimed it could heat an average house with a single warm air register and one return-air inlet, even though the house had two stories.

It looked good on the printed material. Many thousands bought these furnaces on the strength of the advertising - only to find out that they did not heat as they were supposed to. The houses were becoming more spread out and there was difficulty in getting air to some of the more remote rooms. Forced circulation of the air through the heating system was beginning to receive serious consideration.

The first general step in this direction occurred when a furnace fan, placed upon the market about 1920 or 1922, was especially designed for small and medium-sized furnaces. This type fan gave way in the

march of progress and the advancement to the centrifugal blower.

The accepted practice of locating warm-air supply registers in the baseboard on an inside wall of the room was satisfactory when the rooms were large. Trouble started when houses became small during and shortly after World War II. The rooms in these houses were small and usually had only one wall suitable for the placement of much furniture. That same wall usually turned out to be the one wall where the warm air register was located and if the homemaker wanted to place a large piece of furniture along that wall it was just too bad. To meet this problem the register was placed six feet from the floor and over the top of the furniture. It was realized that this would not give satisfactory heating unless the blower operated almost all the time when the weather was cold. That was when C.A.C. (Continuous Air Circulation) was introduced and it worked so well that it has become a standard adjustment for all warm-air systems. About 1950 it was discovered that placing the registers in the floor or wall beneath the windows and locating the return air inlet near the ceiling would greatly improve the heating. That was the start of perimeter heating.

The introduction of automatic heat with oil and gas brought about many revolutionary changes in the design of warm air furnaces. The forced warm air heating system with its blower, ducts and registers makes a natural distribution system for summer cooling equipment and the industry knows it and is doing something about it.

Steam and then hot water heating came into being because people were not satisfied with the kind of heating they were able to get from

stoves and the warm-air furnaces in use at the time. At one time, steam heating was used to some extent in residences but it never was a popular heating method. Very little, if any, steam heating is used in the average moderate-sized home today. Vapor heating is used today, but that operates in quite a different manner.

Not too much is known about the early days of steam heating. It probably got its start when the first steam generators were made to operate the first steam engine. This was about the end of the 17th century. In 1769 Watts made the steam engine a practical machine.

The first steam heating system that we have on record was installed in 1742. It had a crude cast-iron boiler to which was connected copper pipes with shuttered openings in the pipe to allow the steam to escape into the room. It heated the rooms to a satisfactory level but also filled them with steam and vapor.

The first system of indirect heating with steam was installed a few years prior to 1800. Later, indirect systems using hot water instead of steam appeared too. Along about 1800 the first high pressure steam heating system appeared in England, using pressures as high as 130 pounds. The first hot water heating systems that we know about came into being about 1835.

The early designers of these systems were much concerned about the weight of a column of water 30 feet high, pointing out that such a water column terminated in a wooden hogshed would cause the hogshed to "violently burst asunder". Consequently they used wrought iron pipes with $\frac{1}{4}$ inch thick walls made to withstand 3,000 pounds of pressure. The pipes, or tubes as they were called, were compactly coiled back over each other and installed in a brick furnace in the secondary passes where they were

exposed to the hot gases on their way to the chimney outlet and not to the direct heat.

The radiator in those days was nothing to delight the heart of the home-maker, nor did they in any way appeal to the esthetics of the building architects. They were tremendous things - just an assembly of a large coil of pipes usually partially enclosed but not necessarily so. Great progress was made in the design and construction of boilers during the next 50 years and by 1900 they were not far different from what they are today. Greater attention was given each year to boiler economy and to the importance of both direct and indirect heating surface inside the boiler.

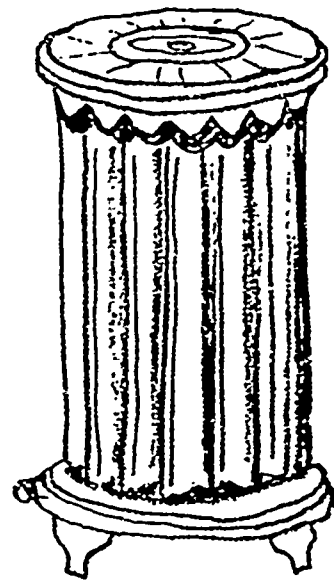

Meanwhile great improvements had been made in the design and fabrication of steel boilers, and were preferred by many heating contractors because they were lighter and occupied less floor space than their cast iron brothers.

Today all but the largest sizes of residential heating boilers are comparatively compact units that are attractive and can be brought into the house as an assembled unit.

Aside from the design of boilers, the industry was faced with problems concerning the distribution system. A lot of work went into the solution of these problems and it was not until about 1910 that all of them seemed to be settled.

Hot water heating systems also were in trouble around the turn of the century. All of them were gravity circulation systems which meant that the

motive power for circulating the water was the difference in weight between heated water and cold water. That was not very much to go on and was insufficient to overcome much resistance in the piping system. This took a change for the better about

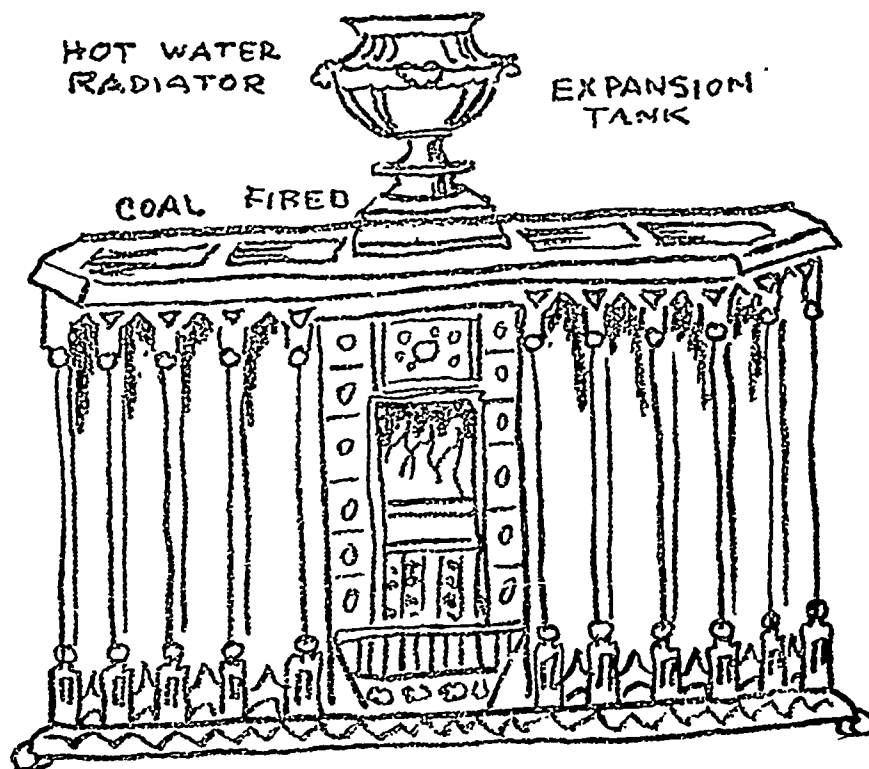

1910 when the heat generator was invented. It was a device placed in the circulating system. Equipped with a column of mercury, it would not permit the water to spill out into the expansion tank until the pressure of the system exceeded 10 pounds. This greatly increased the ability of the water to circulate through the system and made the use of smaller pipes possible.

Circulator pumps appeared about 1930 and they pushed the water through the pipes with a positive force. The sluggishness of the system disappeared overnight. Encouraged by what the pump could do, heating men again turned their attention to the radiation and came up with a long narrow and low radiator that took the place of the conventional baseboard in the rooms and thus for the first time completely inconspicuous.

Early in the 1940's someone hit upon the idea of eliminating the radiators completely by warming the floors or ceilings and let these warm areas in turn warm the rooms. This was strictly radiant heating - something the Romans had done with the old Hypocaust. The general idea was to embed hot water pipes in the form of grids in the concrete of a slab floor or in the

ceiling. The trouble was that the floors got too hot, giving occupants a severe case of the "hot foot" and the ceilings were so warm that the rooms were oppressive. After a bit of research had been completed, the proper temperatures of the floor and the ceilings, too, were discovered and radiant heating with hot water became very comfortable.

We are not always giving good heating systems to the home-maker because too many in the industry think that they must be competitively "cheap". It is impossible to be "cheap" without cutting corners that should not be cut. At any rate, it is a long way from the fire in the cave with a hole in the roof to the regulated heating apparatus of today.

CHAPTER I

GENERAL

16/17

CHAPTER I

In the simplest terms, Energy is the ability to perform work. It may exist in several forms, such as heat energy, mechanical energy, chemical energy, or electrical energy, and may be changed from one form to another. For example, chemical energy in a storage battery becomes electrical energy flowing through a circuit that lights a lamp (light energy and heat energy) or turns a motor (electrical and mechanical energy). Though it may be changed from one form to another, energy cannot be created or destroyed, so that the same relationships of energy transformation always apply.

Heat, a form of energy, is a distinct and measurable property of all matter. Heat cannot be destroyed but can be transferred from one substance to another, always moving from the warmer to the colder substance.

Temperature is the measure of the intensity or level of heat. The unit of temperature most commonly used is the degree Fahrenheit. One degree Fahrenheit is 1/180 of the difference between the boiling point of water and the melting point of ice under standard atmospheric pressure. On the Fahrenheit scale, the boiling point of water is 212 degrees, and the melting point of ice is 32 degrees. Other temperature scales are (1) the Centigrade scale on which the melting point of ice is taken as 0 degrees and the boiling point of water is 100 degrees and (2) the Reamur scale, on which the melting point of ice is 0 degrees and the boiling point of water is 80 degrees. Still other scales, less commonly used, are the Kelvin and Rankine scales.

One unit used to measure given quantities of heat is the British Thermal Unit, more commonly known by its abbreviation BTU. The BTU is the amount of heat energy required to raise the temperature of one pound of water one degree Fahrenheit. Conversely, if the temperature of one pound of water is reduced one degree Fahrenheit, one BTU of heat energy is removed.

A unit of measurement of quantities of heat energy less commonly used is the calorie. A calorie is the amount of heat needed to raise the temperature of one gram of water one degree centigrade. In the field of heating and cooling the BTU is used rather than the calorie to measure quantities of heat.

The rate of temperature change within a substance depends upon the amount of heat energy added or removed within a given time. For example: If a pot of water is placed over a low flame on a stove, it will eventually boil if the temperature of the flame is greater than 212 degrees F. If the flame is turned higher, say to around 600 degrees, the rate of transfer of a quantity of heat is much faster and the water boils sooner. In both cases, the temperature of the water is the same, 212 degrees F., when it boils. On the other hand, if the flame is less than 212 degrees F. temperature, regardless of how long heat was applied, the water would never boil, it would get only as hot as the flame. The same principles apply in temperature reduction. A boiling pot of water will cool to room temperature if heat is entirely removed. It will cool to room temperature faster if it is placed within the freezing section of a refrigerator.

The same quantity of heat is removed, but in a shorter time.

These same principles are used in heating and cooling of spaces within our schools. When the outside temperature is very low, we do not attempt to raise the temperature of the classrooms by setting the temperature of the heating units at the final desired temperature, but by setting it considerably higher. Where air handling units are used for heating and cooling, rapid changes in room temperature are made in either of two ways: (1) by rapidly moving large volumes of air through the space at the desired temperature, or (2) by moving smaller volumes of air through the space, but with a greater temperature difference between the existing temperature and the desired temperature. Moving large volumes of air through a given space can be distracting due to noise, drafts, disturbance of papers, etc. This is why the proper design of any such system requires study and knowledge. The proper operation of any system, within its design limitations, also requires study and knowledge. The improper operation of these systems always produces an unsatisfactory situation and, at times, danger to the building occupants.

The following chart shows some relationships of different forms of energy:

1 horsepower	= 550 foot-pounds (ft-lb) per second
	= 33,000 ft-lb per min
	= 746 watts
	= 2545 BTU per hr
1 horsepower-hour (hp-hr)	= 1 hp for 1 hr
	= 746 watthours (whr)
	= 0.746 kilowatthours (kwhr)
	= 2545 BTU

1 kilowatt (kw)	= 1,000 watts
	= 1.34 hp
1 kilowatthour (kwhr)	= 1 kw for 1 hr
	= 1,000 whr
	= 1.34 hp-hr
	= 3,415 BTU
1 British Thermal Unit (BTU)	= 778 ft-lb
1 Boiler Horsepower	= 33,478.8 BTU per hr (also see Definitions)
1 Ton of Refrigeration (also see Definitions)	= removal of 12,000 BTU per hour
	= removal of 200 BTU per minute

In order to make a study of heating, ventilating, and air-conditioning, it is advisable to become acquainted with the meaning of the following words and terms:

AIR CLEANER - A device which removes air-borne impurities such as dusts, fumes, and smokes.

AIR-CONDITIONING - The process of treating air to control its temperature, humidity, and cleanliness, and the distribution of the air in a given space.

AIROMETER - An instrument for measuring the velocity of moving air.

AIR WASHER - An enclosure in which air is drawn or forced through a spray of water to cleanse and humidify it, or dehumidify it if it contains too much moisture. This is one type of air cleaner.

BAFFLE - A plate or wall for deflecting gases or fluids.

BOILER - A closed vessel in which steam is generated or in which water is heated.

BOILER HEATING SURFACE - That portion of the surface of the heating system which has fluid being heated on one side and heat from fuel on the other, the fluid then being circulated through the system. This surface is measured in the side receiving heat. It includes the boiler, water walls, water screens, and water floor.

BOILER HORSEPOWER - The Centennial Standard, established in 1876, defines one boiler horsepower as follows: "It equals the evaporation of 30 lbs. feed water per hour, from a feed temperature of 100 degrees F. to steam of 70 pounds gauge pressure. This is equivalent to 33,478.8 BTU per hour, or the evaporation of 34.5 lbs. of water at 212 degrees F." There is considerable variance in the exact figures used in computation in different text references; one uses the figure 33,478 BTU, another 33,500, still another uses 33,465. Another method used to express approximate boiler horsepower involves dividing the area of the heating surface (expressed in square feet) by either 10 or 12, depending again upon the text reference used.

BRITISH THERMAL UNIT - The quantity of heat required to raise the temperature of one pound of water one degree Fahrenheit.

BY-PASS - A pipe or duct usually controlled by valve or damper, for short-circuiting fluid flow.

CENTRAL FAN SYSTEM - A mechanical indirect system of heating, ventilating, or air-conditioning in which the air is treated or handled by equipment located outside the rooms served, usually at a central location, and conveyed to and from the rooms by means of a fan and a system of distributing ducts.

COMFORT ZONE - The range of effective temperatures in which most adults feel comfortable.

CONCEALED RADIATOR - A heating device located within, adjacent to, or outside the room being heated which is concealed so that the heat transfer surface is not visible in the room.

CONDENSATE - The liquid formed by condensation of a vapor. In steam heating, water condensed from steam; in air-conditioning, water extracted from air, as by condensation on the cooling coil of a refrigeration machine.

CONDENSATION - The process of changing a vapor into liquid by the extraction of heat. Condensation of steam or water vapor is effected in either steam condensers or in dehumidifying coils and the resulting water is called condensate.

CONDUCTION - The transmission of heat through a material, such as metal, which does not need to move in order to transfer the heat.

CONDUCTOR - A material capable of conducting heat. The opposite of an insulator or insulation.

CONVECTION - The transmission of heat by the circulation of a liquid or a gas such as air. Convection may be natural or forced.

DEGREE-DAY - A unit used in specifying the nominal heating load in winter. Sixty-five degrees Fahrenheit is the base used in figuring heat need, since buildings will usually need heat only when the outside temperature is below 65 degrees. For any day, the degree-days can be found by subtracting the day's average outdoor temperature from 65 degrees F. For instance, if the average temperature is 37 degrees, there are 28 degree-days for that day.

DEHUMIDIFY - To reduce the amount of water in the air.

DEW POINT - The temperature at which water begins to condense from air containing a certain amount of moisture.

DIRECT-INDIRECT HEATING UNIT - A heating unit, located in the room or space to be heated, which is partially enclosed, the enclosed portion being used to heat air which enters from outside the room.

DIRECT-RETURN SYSTEM - A hot-water system in which the water, after it has passed through a heating unit, is returned to the boiler along a direct path so that the total distance traveled by the water is the shortest feasible. Usually there are considerable differences in the lengths of the several circuits composing the system.

DOWN-FEED SYSTEM - A steam heating system in which the supply mains are above the level of the heating units which they serve.

DOWN-FEED ONE-PIPE RISER - A pipe which carries steam downward to the heating units and into which the condensate from the heating unit drains.

DRAFT - Difference in air pressure which causes a movement of air.

DRAFT HEAD - (side outlet enclosures) The height of a gravity convector between the bottom of the heating unit and the bottom of the air outlet opening.
(Top outlet enclosure) The height of a gravity convector between the bottom of the heating unit and the top of the enclosure.

DRY-BULB TEMPERATURE - The temperature indicated by a standardized thermometer after correction for radiation, etc.

DRY-RETURN - A return pipe in a steam-heating system which carries both water of condensation and air. The dry return connects above the level of the water line in the boiler in a gravity system.

EFFECTIVE TEMPERATURE - An arbitrary index which combines into a single value the effect of temperature, humidity, and movement of air on the degree of warmth or cold felt by the human body. The numerical value is that of the temperature of still, saturated air which would induce an identical sensation of warmth.

ELECTRICAL HEATING ELEMENT - A unit assembly consisting of a resistor, insulated supports, and terminals for connecting the resistor to electrical power.

ELECTRICAL HEATING UNIT - A structure containing one or more electrical heating elements, terminals, insulation, and a frame, all assembled in one unit.

ELECTRICAL RESISTOR - A material which produces heat when an electric current passes through it.

FINNED-TUBE RADIATOR - A steam or hot water heat-distributing unit fabricated from metallic tubing with metallic fins bonded to the tube. They operate with gravity-recirculated room air and are designed for installation without enclosure, or with open-type grills or covers, or with enclosures having top, front, or inclined outlets.

FUMES - A broad term which includes all kinds of odors coming from smoke, chemicals, and the like.

FURNACE - That part of a boiler or warm-air heating plant in which combustion takes place. Also a fire-pot or fire-box.

GUAGE PRESSURE - Pressure in pounds per square inch above atmospheric pressure. Guage pressure may be indicated by a manometer which has one leg connected to the pressure source and the other exposed to atmospheric pressure.

HEAT - A form of energy which can be transferred from one material to another when there is a difference in temperature between the two.

HEATING MEDIUM - A substance such as water, steam, air, or furnace gas used to convey heat from the boiler, furnace, or other source of heat to the heating unit.

HEATING SURFACE - The exterior surface of a heating unit. **Extended heating surface:** Heating surface having air on both sides and heated by conduction from the prime surface. **Prime Surface:** Heating surface having the heating medium on one side and air on the other.

HOT WATER HEATING SYSTEM - A heating system in which water carries heat through pipes from the boiler to the heating units.

HUMIDIFY - To add water vapor or moisture to any material, such as air.

HUMIDISTAT - A device for the automatic control of relative humidity.

HUMIDITY - Water vapor within a given space.

HUMIDITY, RELATIVE - A ratio of the amount of water vapor in the air to the amount that the same air can hold, at a given temperature. Expressed as a percentage.

INCH OF WATER - The pressure due to a column of liquid water one inch high at a temperature of 62 degrees Fahrenheit.

INSULATION - A material having a relatively high heat resistance per unit of thickness, used to prevent loss of heat by conduction.

MANOMETER - An instrument for measuring pressures. A U-tube partially filled with liquid, usually water, mercury, or a light oil; pressure applied to one end changes the level of the liquid in the tube, and the change of level is measured to find the pressure.

ONE-PIPE SYSTEM - A steam heating system in which a single pipeline supplies heat to the heating surface and returns the condensate.

PANEL HEATING - A heating system in which heat is transmitted by both convection and radiation from panel surfaces to the surrounding air and surface.

PLENUM CHAMBER - An air compartment maintained under pressure and connected to one or more distributing ducts.

POTENTIOMETER - An instrument for measuring or comparing small electromotive forces.

POWER - The rate of performing work; usually expressed in units of horsepower, BTU per hour, or watts.

PSYCHROMETER - An instrument for measuring the humidity or moisture content of the air.

PYROMETER - An instrument for measuring high temperature.

RADIATION - The transmission of heat through space by wave motion. Radiant heat travels in straight lines. It does not need any material such as air to transmit it.

RADIATOR - A heating unit exposed to view within the room or space to be heated. A radiator transfers heat in straight lines by radiation, and by conduction to the surrounding air which in turn is circulated by convection; a so-called radiator is also a convector but the single term "radiator" has been established by long usage.

RECESSED RADIATOR - A heating unit set back into a wall recess but not enclosed.

REFRIGERANT - A substance which cools by absorbing heat through expansion or vaporization.

RETURN MAINS - The pipes which return the heating medium from the heating units to the source of heat supply.

ROOF VENTILATOR - A device on the roof of a building through which air is removed.

SATURATED AIR - Air which contains as much water vapor as possible without condensation.

SPACE HEATER - A self-contained heating unit used to heat a single room or space. They may be classified as to type of fuel used, method of heat distribution, and design features.

SMOKE - Carbon or soot particles which result from the incomplete combustion of such materials as coal, tar, oil, and tobacco.

SPECIFIC GRAVITY - The ratio of the weight of a body to the weight of an equal volume of water at some standard temperature, usually 39.2 degrees Fahrenheit.

SPLIT SYSTEM - A system in which the heating and ventilating are accomplished by means of radiators or convectors supplemented by mechanical circulation of air from a central point.

STACK HEIGHT - The height of a gravity convector between the bottom of the heating unit and the top of the outlet opening.

STATIC PRESSURE - Air pressure used to overcome frictional and other resistance to air flow through a duct.

STEAM - Water in the vapor phase. Dry saturated steam is steam at the saturation temperature according to the pressure, and containing no water in suspension.

STEAM (Continued) - Wet saturated steam is steam at the saturation temperature corresponding to the pressure, and containing water particles in suspension. Superheated steam is steam at a temperature higher than the saturation temperature corresponding to the pressure.

STEAM HEATING SYSTEM - A heating system in which heat is transferred from the boiler or other source of steam to the heating units by means of steam at, above, or below atmospheric pressure.

STEAM TRAP - A device for allowing the passage of condensate and preventing the passage of steam, or for allowing the passage of air as well as condensate.

SUPPLY MAINS (STEAM) - The pipes through which the steam flows from the boiler or other source of supply to the run-outs and risers leading to the heating units.

SURFACE CONDUCTANCE - The amount of heat transferred by radiation, conduction, and convection from a given area of a surface to the air or other fluid in contact with it, or vice-versa.

THERMAL CONDUCTANCE - The rate of heat flow through a given area of a body, of a given size and shape within certain temperature differences.

THERMOSTAT - An instrument which responds to changes in temperature and which directly or indirectly controls the source of heat supply.

TON OF REFRIGERATION - The removal of heat at the rate of 200 BTU per minute, 12,000 BTU per hour, or 288,000 BTU per 24 hours. A two-ton unit, for instance, removes 400 BTU per minute. The term "ton of refrigeration" is based upon the amount of heat needed to melt one ton of ice.

TWO-PIPE SYSTEM (STEAM OR WATER) - A heating system in which one pipe is used for the supply of the heating medium to the heating unit and another for the return of the heating medium to the source of heat supply. In a two-pipe system each heating unit receives a supply of the heating medium directly from the furnace.

UNDERFED DISTRIBUTING SYSTEM - A hot-water heating system in which the main flow pipe is below the heating unit.

UP-FEED SYSTEM - A steam heating system in which the supply mains are below the level of the heating units which they serve.

VACUUM HEATING SYSTEM - A two-pipe steam heating system which can be operated below atmospheric pressure when desired.

VAPOR - Any substance in the gaseous state.

VAPOR HEATING SYSTEM - A steam-heating system which operates at or near atmospheric pressure and which returns the condensate to the boiler or receiver by gravity. Vapor systems have thermostatic traps or other means of resistance on the return ends of the heating units for preventing steam from entering the return mains; they also have a pressure-equalizing and air-eliminating device at the end of the dry return.

VELOCITY - The rate of motion of a body in a fixed direction. In heating systems it is expressed in feet per second. Velocity equals distance divided by the time.

VENTILATION - The process of supplying or removing air by natural or mechanical means to or from any space. Such air may or may not have been conditioned.

VISCOSIMETER - An instrument for measuring the viscosity of oil.

VISCOSITY - The measure of oil's rate of flow. It is determined by the length of time required for a designated amount of oil at a definite temperature to flow through a tube of standard size.

WARM-AIR HEATING SYSTEM - A warm air heating plant, consisting of a heating unit enclosed in a casing, from which the heated air is distributed to the various rooms of the building through ducts. If the motive head producing flow depends upon the difference in weight between the heated air leaving the casing and the cooler air entering the bottom of the casing, it is termed a gravity system. If a fan is used to produce circulation and the system is designed especially for fan circulation, it is termed a forced air furnace or a fan furnace system or a central fan furnace system. A fan furnace system may include air washers and filters.

WET-BULB TEMPERATURE - The temperature registered by a thermometer whose bulb is covered by a wetted wick and exposed to a current of rapidly moving air. It is used in measuring the humidity of the air.

WET-RETURN - That part of a return main of a steam heating system which is filled with water of condensation. The wet-return is usually below the level of the water line in the boiler, although not necessarily so.

CHAPTER II

FACTORS DETERMINING HEALTH AND COMFORT

CHAPTER II

Many of the factors which must be considered in determining the health and comfort of the students in the classroom include temperature, humidity, air movement, odor, dust, and noise. In addition, we must take into consideration the heat generated by the students and light as well as the loss of heat through windows, open doors, roofs and walls.

Looking first at the room TEMPERATURE, we run into the question of what is proper room temperature? This is always a controversial question. A comfortable temperature is one which will balance the rate of heat generation in the body and the rate heat loss from the body. Of course, the lower the temperature of the room, the higher will be the rate of heat loss. But the rate of heat generation is not so easily controlled. It varies between individuals and between males and females and changes with age. In practice, we must work with averages and adopt standards of temperature, humidity, and air motion that gives the greatest comfort to the greatest number of people. It is impossible to set up any one fixed standard for comfort that will give universal satisfaction, especially in schools where there is so much difference in ages of those whom the engineer is expected to serve. The person who reports the temperature conditions is usually the teacher, who is older than the pupils in the room. Since the rate of metabolism and heat generation decreases as a person grows older, the teacher, generating heat at a lower rate, requires warmer surroundings than does the younger people. The amount of insulation varies, too. For example, girls generally wear a lighter clothing than do boys.

Different parts of the building are kept at different temperatures.

The following list of preferred temperatures should serve as a guide:

<u>AREAS</u>	<u>DEGREES</u>
Classrooms	68-72
Offices	68-72
Assembly Halls (when used)	68-72
Manual Training Rooms	65-72
Corridors	65-70
Gymnasiums	60-70
Toilets	60-65
Locker and Shower Rooms	76-80
Swimming Pools	80-86
Open Air Room	60-64
Kindergartens	72-74
Kitchens	66-70
Cafeterias and Lunchrooms	68-72

Due to the wide variation between individual teachers temperature desires, many temperature controls are sealed, in that, adjustments either require a special tool or the case must be removed. It would be a good idea for the custodians to check the temperature in the room frequently each day. Some schools have set up a chart for each room on which the teachers or pupils note the temperature at stated intervals during the day. Then the custodian can use this information to adjust the amount of heat delivered. The temperature of classrooms should be taken somewhere near the center of the room about 4 to 5 feet from the floor, at a point which does not receive direct heat from the heating unit.

Automatic thermostatic controls, when properly set, will provide fixed temperatures at all times. If the room gets too hot, the heat will shut off. It is your duty to see that the automatic controls are in good working order.

Open windows often affect the heating system. This practice however is not desirable. There are two important factors to be considered when using the windows as a "thermostat." If a room is warm and a window is opened, the thermostat will respond to the cold air and deliver still more heat. If this thermostat is controlling a "zone", hence all others in that zone will be overheated to an extremely uncomfortable degree. The second point is a matter of economy. Units are delivering unwanted heat while windows are open to obtain cool air, resulting in excessive fuel consumption.

HUMIDITY

Humidity plays an important part in the comfort of school children. The amount of water that the air is actually carrying, relative to the amount it can carry is called relative humidity. A relative humidity of 30-60% is satisfactory for classrooms with the most desirable range being from 40-50%. Warm air carries more moisture than cold air. A temperature of 68° with a relative humidity of 62% gives about the same feeling of comfort as does 70° with a relative humidity of 47% or 75° with 15% more fuel, so relative humidity is an important factor in heating costs. Modern heating plants control humidity through the use of atomizer sprays or evaporating humidifiers.

ODOR CONTROL

Human body odors, cooking odors, chemistry lab odors, cloakroom odors, shower room and other such odors are not toxic, but should be removed from the building and replaced with new, clean air. The new air may be outdoor

air or air that has been cleared of odors by washing or some other means. Regardless of how the odor-free air is supplied, the custodian uses his ventilation or air-conditioning system to add to pupil comfort.

AIR MOVEMENT

No definite rules have been established for determining the flow of air needed to maintain sanitary conditions in a classroom. It would be well for those designing school plants to provide equipment that will make it possible to move large volumes of outside air through the building, if it seems desirable.

The provision and control of proper air motion throughout an occupied space is one of the difficult problems of air handling. Air motion is cooling and must be considered in determining comfortable temperatures. It should be at a minimum in winter and a maximum in summer. In classrooms it will be confined by practical limitations to 15-25 cubic feet per minute per occupant.

DUST

The ease or difficulty of controlling dust may depend upon the location of the school. Schools in such areas as New York or Illinois may have very little dust, however, schools of the Great Plains and desert areas, constantly experience problems with dust and often find it very difficult to control. Any school located near unpaved streets or roads will find dust and dirt filtering into the classrooms, which necessitates closing the windows. This is uncomfortable during warm weather unless the school has other air conditioning or ventilation, and of course, dust means extra cleaning work, as well.

NOISE

Noise will have a decided effect upon students and their work. Schools located near railroad tracks, jet airports, heavily traveled highways, or an area of intense activity may find noises very distracting. Classroom work

may have to come to a halt while a jet takes off or a long freight train goes by. Windows may have to be kept closed even in warm weather, which will then call air-conditioning or ventilating units into use. The constant hissing of steam from radiators, the hammering of steam pipes, and the sound of ventilating or air-conditioning fans are noise problems which custodians are often asked to try to minimize.

ACTIVITY

Custodians, as well as teachers, often forget what effect a classroom full of children will have on the heating and cooling system. A human being generates more heat than you may realize. Each child gives off from 240 to 400 BTU per hour, or as much heat as a 100 watt light bulb. This means that if a classroom is at the proper temperature when the children come into it in the morning, it will soon be too warm. An average class of 30 children can raise the temperature of a room from 68° to 70° within an hour when the temperature outside is 30°. At these temperatures, the youngsters compensate for 35% of the heat loss of 21,000 BTU. When they leave for a 20 minute recess, the classroom will cool off again. Unless the rooms are provided with individually controlled unit heaters and ventilators, the custodian will have to consider problems of heat control for each classroom.

CLASSROOM LOCATION

Classroom location is an important factor in temperature control. In the Northern part of the state, classrooms located on the windward side of the building will be as much as 10° colder than those on the opposite side. This temperature difference is especially noticeable in older buildings. A room which faces South will receive more heat from the winter sun than one which faces North. For example, on an average clear day in the wintertime, the sun's direct radiation through the windows of a south classroom exceeds

48,000 BTU's per hour. The same school classrooms facing East receive approximately 25,000 BTU's per hour in the morning. The classrooms facing West, receive the same amount in the afternoon. Of course, rooms on the East side of the building receive sun heat in the morning, while those on the West are warmed by the afternoon sun. The story on which the classroom is located also has an effect on the heating problem. A center-story classroom is much better protected from extremes of temperature than are those in the upper and lower stories.

CONSTRUCTION MATERIALS

Heat losses in classrooms will depend also upon materials used in the construction. Glass blocks and large amounts of glass on the sun side of the building cause the interior temperature to rise remarkably when the sun is shining.

AMOUNT OF LIGHTING

Incandescent lighting fixtures produce heat. Every watt of electricity used for light produces 3.4 BTU per hour. Thus, in a classroom with 4,000 watts of incandescent illumination, the lighting fixtures will produce 13,600 BTU per hour or 65% of the heat needed to maintain room temperature when the outside temperature is 30° F.

All of these factors must be taken into consideration in planning for temperature control. The variables make it difficult for the custodian to maintain the classroom temperatures in a comfortable range.

CHAPTER III
HEATING SYSTEMS

CHAPTER III
HEATING SYSTEMS

Heating systems in schools may be classified into 6 general classifications:

1. Hot air
2. Hot Water
3. Steam
4. Radiant or panel
5. Unit
6. Combinations of two or more of these.

HOT AIR SYSTEM (See Figure 1)

In the hot air system, air is heated on metal surfaces in the heating unit and is carried to the room by gravity or by fan.

Some of the advantages of the hot air system are:

1. Heating or ventilation may be combined into one unit.
2. It is easily operated.
3. Does not require elaborate equipment.
4. Lends itself readily to humidification.
5. Usually so designed that fresh air can be introduced.

Some of the disadvantages of the hot air system are:

1. Open windows and air pressure affect the proper distribution of heat.
2. The equipment is large and requires more space than other types.
3. Air ducts leading to rooms require more space than other types.

A TYPE OF HOT AIR SYSTEM

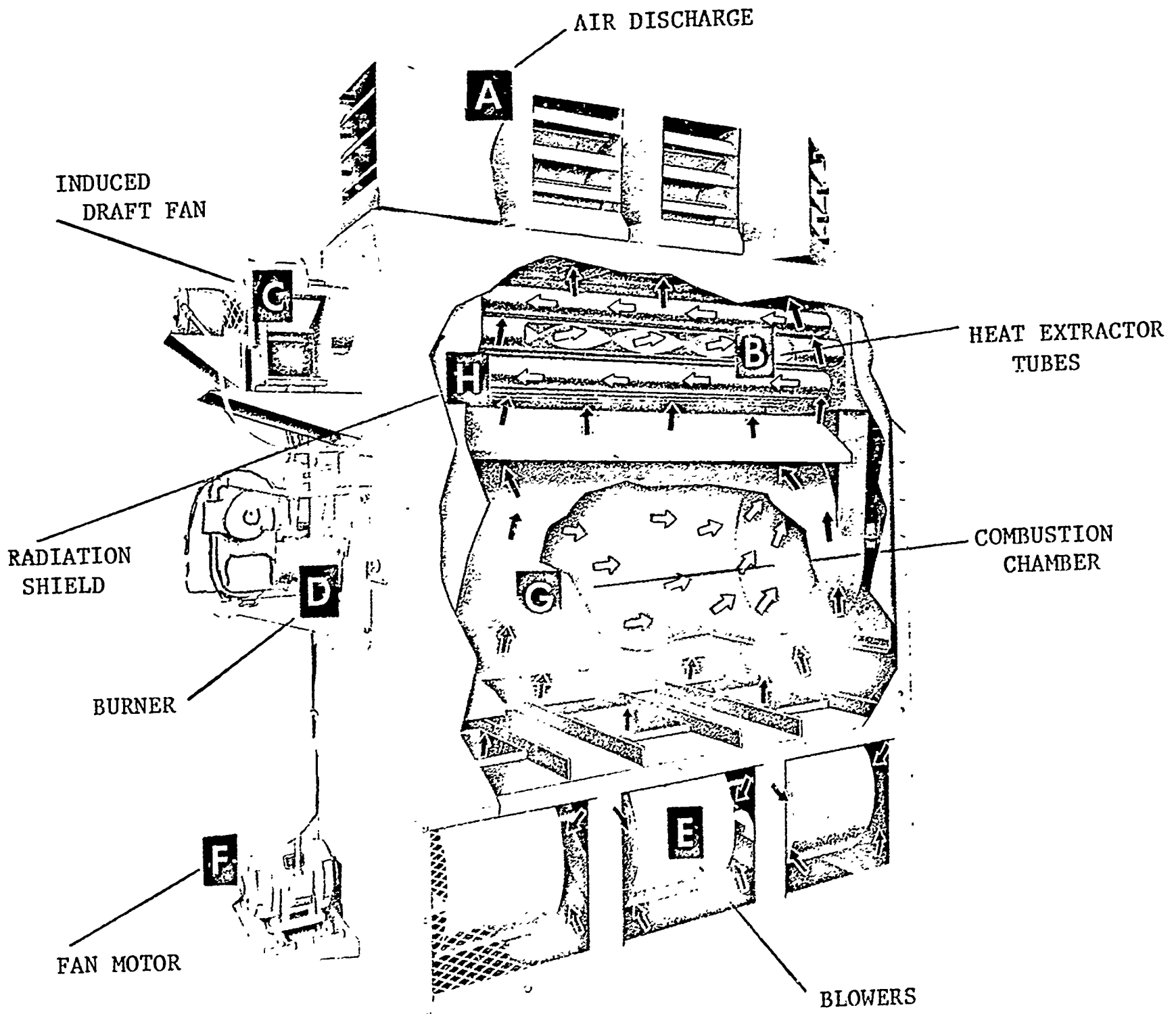

FIGURE 1

4. Air movement may be noisy if the air is moved rapidly or if the heating ducts are full.
5. Odors and fumes may be transferred to all parts of the building.
6. Offers a greater fire hazard than other types.
7. Areas to be heated must be comparatively near furnace.

HOT WATER SYSTEM (See Figure 2)

In a hot water system, water is heated in a boiler and piped to the rooms by gravity or by forced circulation.

1. The large quantity of water provides uniform heat. It does not cool off as quickly as steam or hot air.
2. The temperature can be maintained 24 hours a day.
3. Temperature can easily be controlled automatically.

The disadvantages of a hot water system are:

1. It requires larger radiators than steam system.
2. The area to be heated must be located comparatively near the boiler room.
3. It requires a greater length of time to raise the temperature of the building.
4. Greater damage results from broken pipes than in the case of steam.

STEAM HEAT SYSTEM (See Figure 3)

The advantages of a steam heat system are:

1. It is easily controlled.
2. Heat is evenly distributed.
3. It is economical to operate and to install.
4. The boiler need not be located near the area to be heated, although it is desirable.
5. Large amounts of heat is conveyed in a small amount of liquid.

HOT WATER SYSTEM

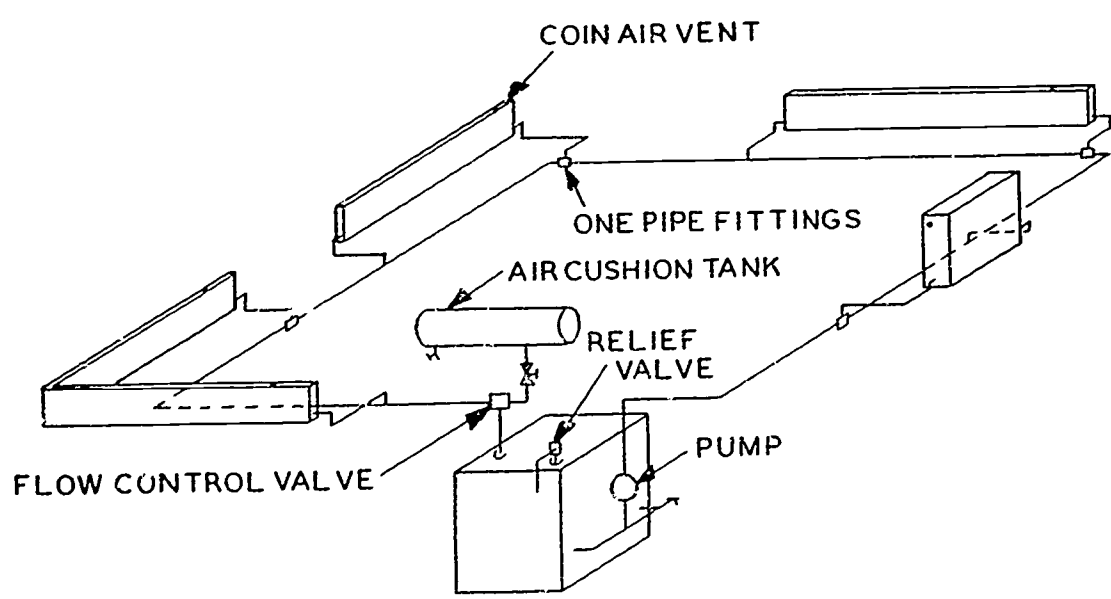
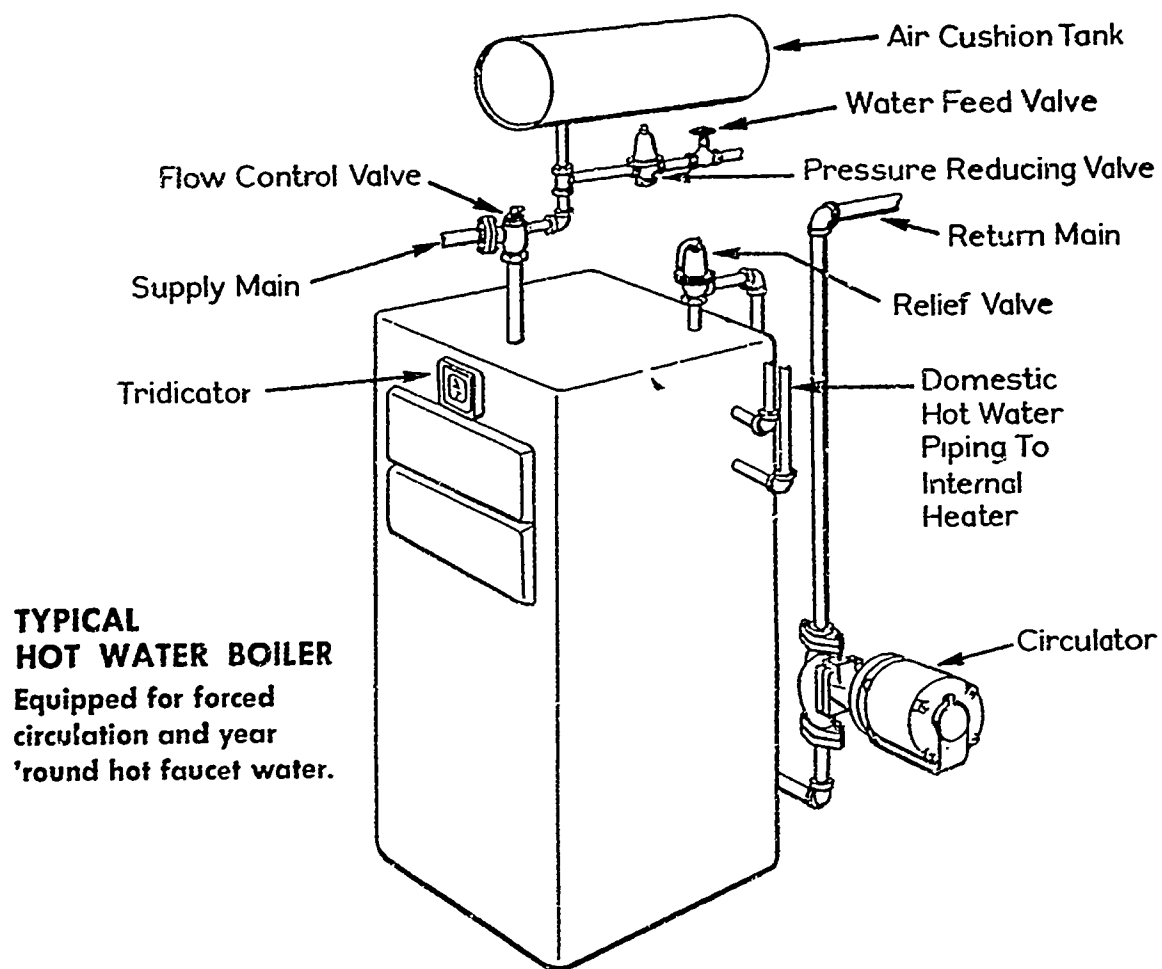

Schematic one-pipe forced hot water system (closed system)

FIGURE 2

STEAM HEAT SYSTEM

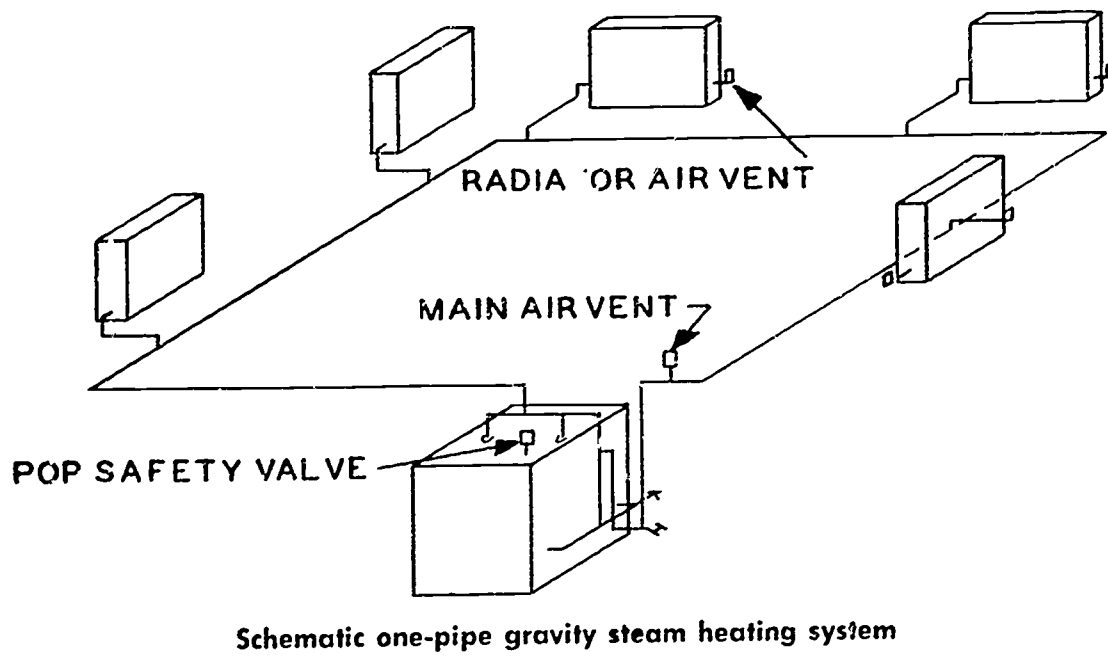
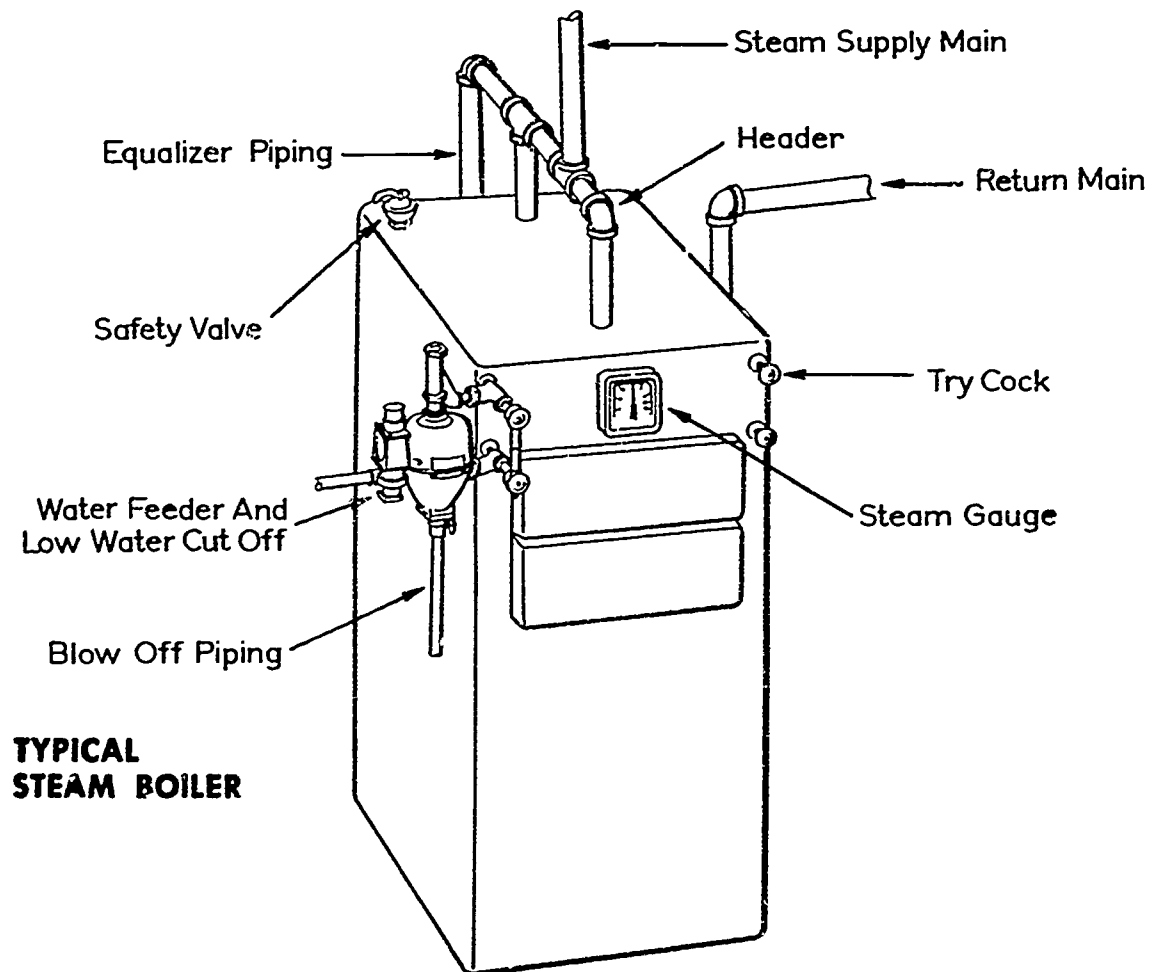

FIGURE 3

The disadvantages of a steam heat system are:

1. Radiators must deliver full output or be turned off completely if they are not equipped with thermostatic controls.
2. The system must be kept in good repair to operate economically.

PANEL HEATING (See Figure 4)

Panel, or radiant heating, has not been installed to any great extent in school buildings. It consists of heated pipes or ducts embedded in the floor, wall, and/or ceiling. It gives promise of becoming a very satisfactory means of heating certain school buildings. Panel or radiant heating is useful in kindergarten rooms since it provides a warm floor for children who spend a great deal of time on the floor. It provides uniform heat.

Some of the advantages of the panel heating system are:

1. A steady temperature.
2. Little temperature differential between the floor and the ceiling.
3. Warm floors.
4. Lack of violent drafts if windows are open.

The disadvantages of a panel heating system are:

1. Considerable time lag in heating and cooling.
2. Leakages are hard to repair.
3. Floors may be too hot in cold weather for the comfort of children.
4. It softens the mastic and tile of resilient tile floors.

Electrical heating is also used in panel and radiant heating. It is a method of growing importance.

Summer air-conditioning requires a great deal of electricity. In looking for a way to maintain the demand for electricity, the year round, many electric companies are encouraging the use of electricity for heating homes and schools. As they are offered lower rates, schools of the South are using this medium to some extent. There are even some schools in the

PANEL HEATING SYSTEM

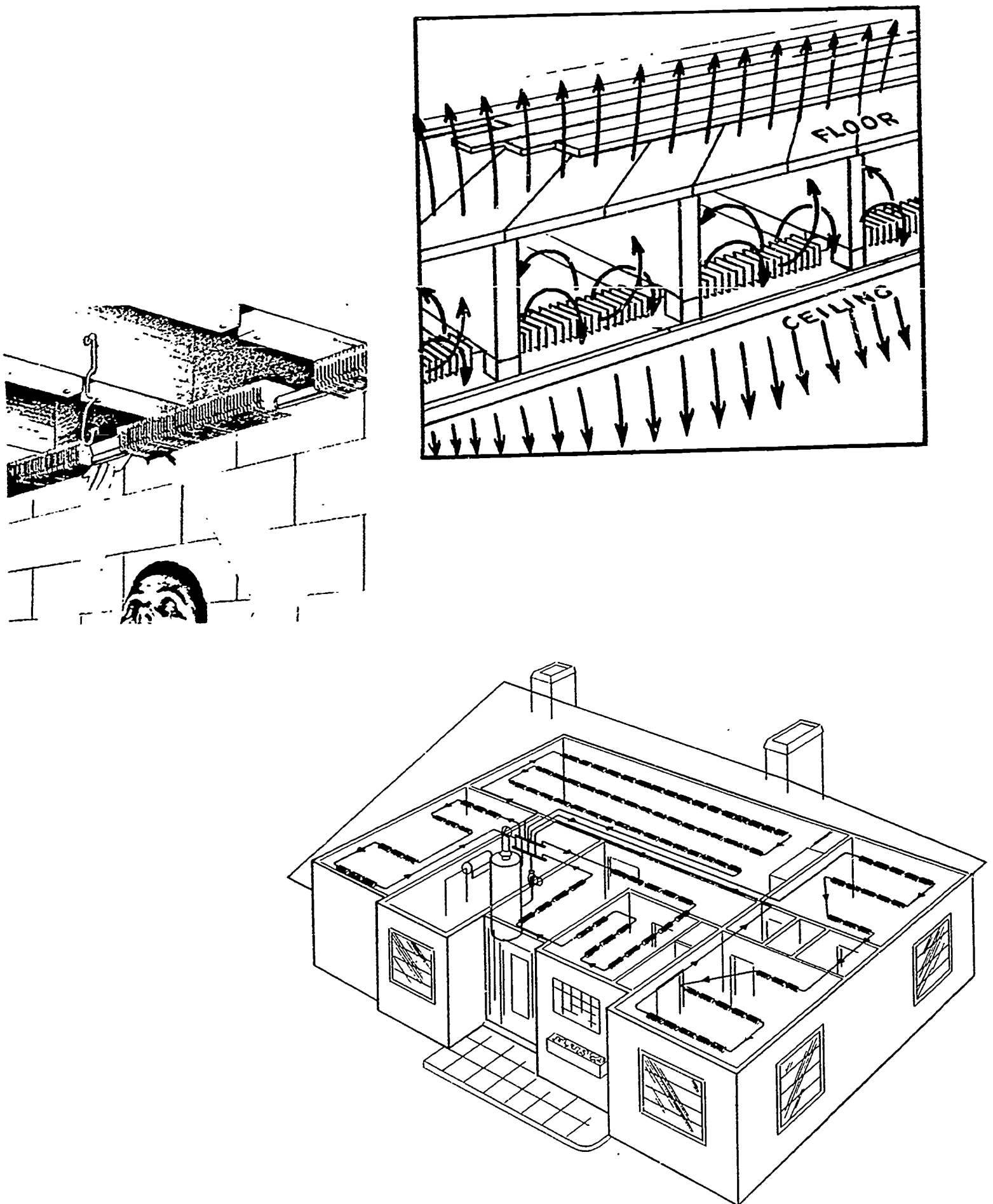

FIGURE 4

Northeast portion of the United States which are using electrical heat.

The advantages of using electrical heat are:

1. The cleanliness of the system.
2. Less custodial service is needed.
3. Lower initial costs since no boilers, stacks, or tunnels are needed.
4. Low maintenance cost.

The disadvantages of using electricity for heating are:

1. It may not provide enough heat in colder areas.
2. The high fuel costs.

UNIT HEATERS (See Figure 5)

Unit heaters are simply heating units with a fan to blow air across them. Heat may be supplied by three different means:

1. Hot water or steam.
2. Electricity
3. Direct fire from gas, oil

Unit heaters may be hung from the ceiling or placed on the floor. Ceiling units are used primarily in industrial shops and gymnasiums, where the fan noise is not too objectionable. They utilize either direct fire or piped heat. Small electrical floor units are often used for supplementary heat in offices, locker rooms, ticket booths, etc. The operation of the fan is thermostatically controlled. In hot weather, the fan may be used to move unheated air in shops.

HEAT PUMPS (See Figure 6)

Some schools within the State of Florida have had a heat pump installed for either heating, cooling, or both. The principal of the heat pump and mechanics of its use will be discussed in Chapter XI in the manual.

COMBINATIONS

One of the most common combinations is that of hot water or hot air and steam in which air taken from outdoors is heated by means of steam or hot water, either in the basement or in the classroom itself and then circulated. A unit heater may be constructed to take air from the outside and off the floor, heated, and circulated about the room. This system permits control of heat and ventilation in each room and eliminates the fan room, steam coils, and supply ducts used with a central system. It is also possible to control humidity with this system.

CHAPTER IV
HEAT GENERATORS

52/53

CHAPTER IV

HEAT GENERATORS

Heat generators may be classified in several ways such as to type, whether it is a central unit heater, and the construction, whether it is cast iron, steel, etc.

Steam and hot water boilers for heating are made of cast iron or steel. Cast iron boilers are usually (1) of rectangular pattern with vertical sections and rectangular grate commonly known as a sectional boiler; or (2) of round pattern with horizontal, pancake sections and circular grate commonly known as a round boiler. Sectional boilers are usually used for heating schools, while round boilers are more often used as hot water heaters.

Boilers may be classified in several other ways. The more common methods of classification are as to pressure, material use, and design. Boilers may be either high or low pressure. In a high pressure system, as it is usually defined, the boiler plant generates steam at a gauge pressure exceeding 15 pounds. A low pressure system is one which generates pressures of less than 15 pounds. A low pressure system is by far the most desirable for school plants for the following reasons:

1. Low pressure boilers are cheaper to install and maintain.
2. Cost of repairs to piping and auxiliary equipment is less.
3. Low pressure systems are more easily operated and are less dangerous.
4. Less space in the boiler room is required.
5. High pressure boilers must have an operator in the boiler room at all times, thus the operator is not available for other duties.

6. Low pressure boilers may be placed in full load operation more quickly than high pressure boilers.
7. Low pressure systems require fewer accessories.

CLASSIFICATION OF STEAM HEATING SYSTEMS

Steam heating systems may be classified as to pressure, vapor, and vacuum.

Pressure systems may be classified into the following types:

1. One pipe gravity systems.
2. Air return systems.
3. Two pipe gravity return systems.
4. Condensate pump and wet return.

A one pipe gravity system is the simplest way to distribute steam for heating purposes, but at the same time, is one of the most expensive to install because it requires large steam risers and lines which also require large radiator valves. (See figure 5)

In this system, the steam and condensate both flow in the same line but in the opposite directions and have but one connection to the radiator. The radiator is so placed that the condensate leaves the radiator at the same connection at which the steam entered.

The air is eliminated from the radiators and lines by air valves placed at the coolest point of the radiator and large air valves at the top of the drop where condensation returns to the boiler. The air valves are automatic. They will allow air to leave the system until the steam or water strikes them, then close so the steam or water does not escape.

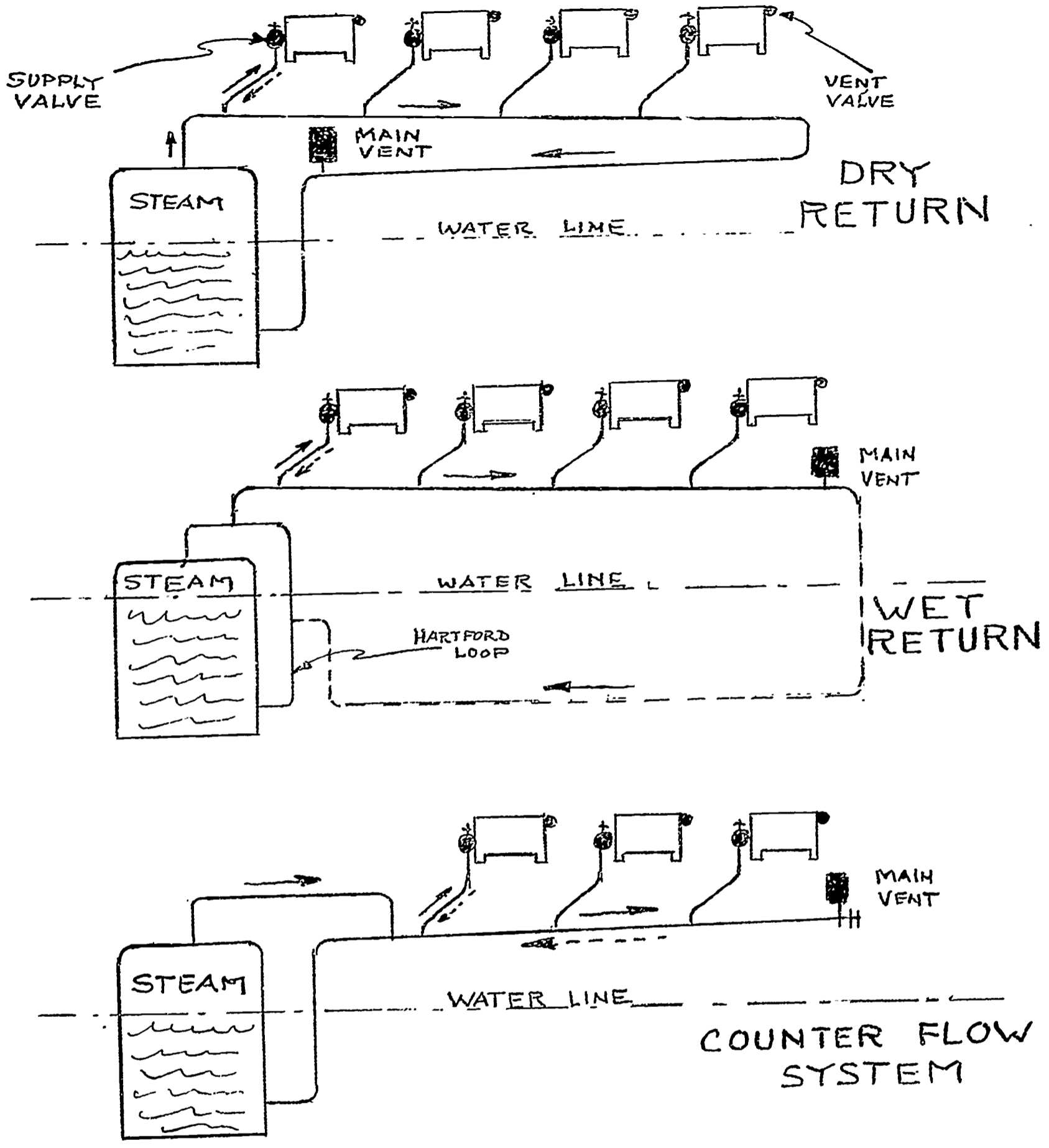

ONE PIPE HEATING SYSTEM
(THERE ARE OTHER VARIATIONS)

FIGURE 5

The steam pressure required to operate this system may be anything under five or six pounds of steam per square inch as there are no parts of this system that it would injure.

An air line system is exactly like a one-pipe gravity system except that the air valves are left off the radiator and drops, and a thermostatic air line valve is used instead. A system of small piping is connected to those air line valves which lead to an air line pump in the boiler room. The air line pump removes the air from the radiators and lines but handles no water. This air line system may be operated without the pump if so desired, by opening the air lines to the atmosphere, allowing the air to escape. Care should be taken to close the large radiator valves tightly so that the steam cannot enter the radiator and keep the condensate from returning to the boiler.

In a two pipe gravity system, smaller piping may be used, but a double system is required. The steam is distributed in one line and condensation is returned to the boiler in the other. Ordinary air valves are generally used in the radiator drops of the return lines. Impulse check valves, when used on the discharge end of the radiators, give the best results. The pressure in a two pipe system should be as low as possible to insure a complete circulation of steam; four or five pounds pressure will not injure the system.

By replacing the ordinary air valves with vacuum air valves, this system may be operated under a vacuum. The vacuum is produced by building up steam pressure and then cutting down the fire so that the whole system remains hot with four or five inches of vacuum indicated by the boiler.

TWO PIPE DOWN FEED WITH
CONDENSATE PUMP

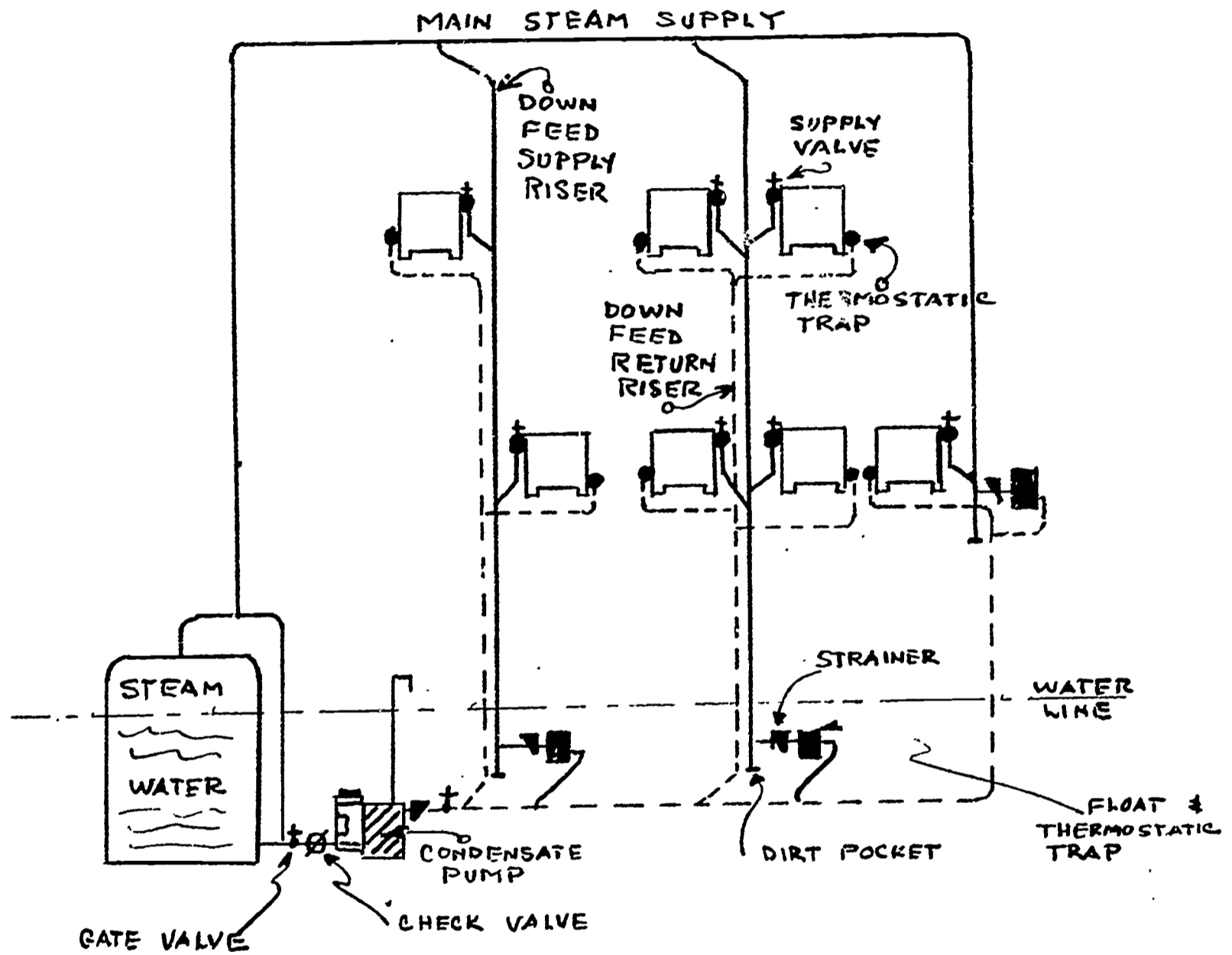

FIGURE 6

A. Condensation pump (See Figure 6) is required when part of the radiators and return lines are below the level of the water lines in the boiler. In this case, condensation cannot return by gravity. Therefore, the condensation is drained into a receiver at atmospheric pressure and an automatic condensation pump feed it into the boiler under pressure. An atmospheric relief valve is placed at the top of the receiver for the elimination of air and this system cannot be operated under vacuum. Ordinary air valves are generally used on radiators, but by the proper grading of radiators and return lines, the air valves may be left off the radiators and all air eliminated through the atmospheric valve on the receiver.

B. A vapor system is very delicate and for that reason is very seldom installed. It is simply a two pipe gravity system with special features for the elimination of air. No air valves are used on the radiators or drops of the returns, but a special dry return line is taken off the regular return lines and is carried to the boiler room where an air exhauster is used to discharge the air at or below atmospheric pressure. In this system, steam pressure must be kept as low as possible, not to exceed eight ounces at the most. If steam pressure should increase, the condensate would clog the exhauster and stop the circulation of steam in the whole system.

C. The vacuum system of a complete two pipe system employs thermostatic traps at the ends of steam mains and the discharge end of radiators. Condensate is returned to the boiler by the use of a vacuum pump which is a combination air pump and water pump. This system is generally used where long runs are required, sometime in buildings 1,000 feet or more from the boiler room. Air is eliminated through the thermostatic traps in the

return lines and is ejected from the system by the vacuum pump.

Steam pressure should be held below $2\frac{1}{2}$ pounds at the boiler or the excessive heat in the steam will injure the traps. Care should be taken in closing down this system and the vacuum pump should be allowed to continue operation for some time after the fire is closed off. This will prevent water hammer in the steam lines when the plant is started next time.

BOILER PARTS AND THEIR USES

The custodian should know the various parts of his boiler and their uses so that he will be able to understand their function and thereby become a better operator.

Since there are many types of boilers as well as many types of accessories on some boilers it is not practical to discuss them all. The important parts are listed below along with their functions.

Safety Valves

There are three kinds of safety valves on steam boilers; the deadweight, the weight and lever, and the spring load. The deadweight valve, as its name implies, is the direct loading of the valve with weights. The ball and lever valve has the lever balanced on the valve stem with an adjustable weight on the lever for variations of pressure. The spring load valve usually has a pop valve which is held down by the tension of a coiled spring, which can be adjusted to the desired pressure.

Safety valves are installed on all boilers to relieve excess steam pressure. It is important that safety valves be tested once each day the boiler is in operation to see if it is stuck on its seat. If a safety valve is stuck, the boiler must be operated by watching the

pressure very closely until it can be repaired or a new one installed. To test the safety valve, pull the chain which is attached on the valve lever so that the valve is lifted off the seat. If steam escapes, the valve is clean and in working order. A valve leak can sometimes be stopped by holding the valve open which will blow dirt off the valve seat.

On low pressure boilers, the safety valves are set at 10 to 15 pounds. The safety valve on the section boiler which is held together by stay bolts should be set to pop off at low pressure.

Pressure and Vacuum Gauges

The gauge most commonly used is called the Bourbon gauge, which consists of an elliptical tube, bent into almost a complete circle. The lower end is connected to the pipe where the pressure is admitted. The other end is closed and attached to a lever which operates the shaft upon which the hands or indicators are fastened. The hand should always be set at 0 when there is no pressure. If pressure is applied, the tube has a tendency to straighten out which operates the needle.

Vacuum gauges operate in the opposite way: that is, when vacuum has been created, the tube contracts and the hand indicates the number of inches of vacuum. All such gauges should be checked often to determine whether they are operating properly.

Water Columns and Water Cocks

This arrangement usually is connected to the side of the boiler so that the level of the water in the boiler is shown in the vertical tube. It is always wise to drain the water from the water glass at least once

or twice a day. If the water does not rise quickly in the glass after the cock has been closed, apparently there is foreign matter in the indicator which prevents it from working as it should. It is also wise to open the petcocks which are usually fastened to the side of the indicator at three levels. Be sure that water drains out of the cock below the level at which the water in the boiler should be carried. It is also wise to open the others at intervals to be sure that they are kept clean.

Check Valves

There are three types of check valves in general use in connection with the heating system. They are the ball check, the lift check, and the swing check. Check valves are used on water lines, or in lines where water must flow in only one direction. The check valves open to permit the flow in that direction, and close the pipe when the water flows in the opposite direction. Swing valves are often used on boilers and return lines where there is little pressure behind the water, because these valves are almost evenly balanced and require very little pressure to open.

Ball checks and lift checks require much more pressure to lift the valve from the seat and are not practical for this work, but they are preferable for high pressure and compressed air. If a check valve fails to work, it should be taken apart and cleaned. If the seat is badly damaged, it may be necessary to install a new seat, if possible, or replace the valve.

FUSIBLE PLUGS

Fusible plugs are located on the crown sheet, in tube locations;

also at heads, fronts, and rears at water levels. The indirect plug has a 1 and 1/2 inch pipe and valve arranged and connected at the rear top section of the shell extending to the interior surfaces above the tube surfaces. The fusible plugs are often connected by the top opening of the pipe on the exterior location of the shells, their purpose being to relieve the pressure if the safety valve fails to operate. These brass plugs have a hole drilled all the way through them. The hole is filled with pure tin or some other soft metal which melts at about 600° F and lets pressure blow off; this lessens the danger of boiler explosion.

FEED-WATER REGULATORS

These regulators automatically control the water supply so ~~that the~~ level in the boiler is maintained at a constant level. They promote safety and economy of operation and lessen the dangers of too little or too much water. Uniform feeding of water prevents the boiler from being subjected to the expansion strains that result from the temperature changes by the irregular water feed. Thermohydraulic and thermostatic expansion-tube, water-feed regulators are the two most common types.

BLOW DOWN APPARATUS

Water fed to the boiler contains impurities in the form of suspended or dissolved solids. When the steam leaves the boiler, most of these impurities are left behind. Some settle to the bottom of the boiler while others float on the surface of the water, so it is necessary to have both surface and bottom blow-off lines on some boilers. Surface blow-off connections may be stationary or floating. Both are used to remove oil from boiler water. Such foreign matter as scale, settlement, and rust is removed from the bottom of the boiler by blowdown valves. Because hot

VALVE ASSEMBLY FOR CONTROL OF WATER OR STEAM

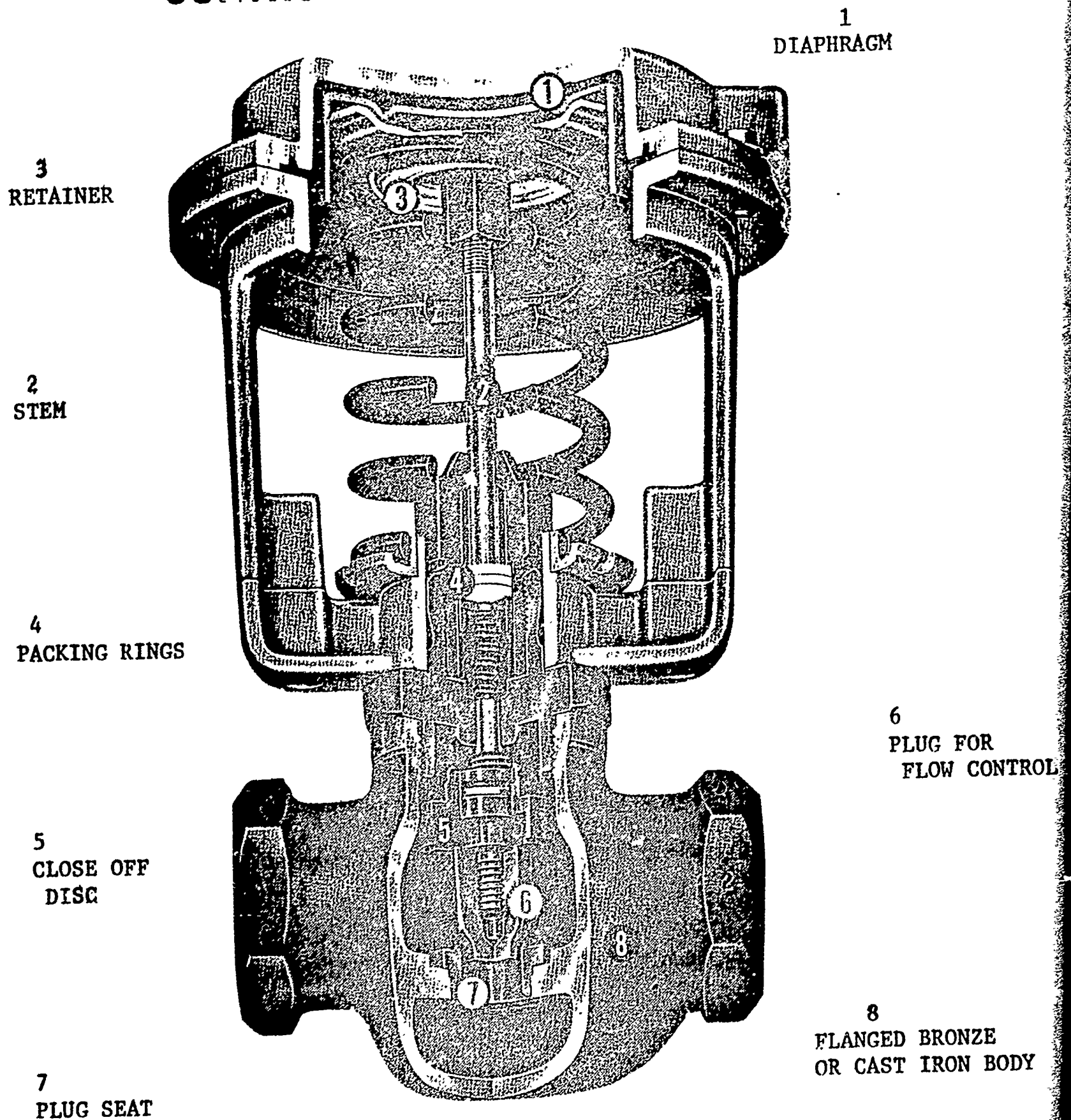

FIGURE 7

water and steam are harmful to the sewer, a separate blowoff tank is provided from which the water is drained off into the sewer as it cools.

CARE OF THE BOILER

Most custodians know that the water level in the boiler should be kept to a certain height. They know that the water level is supposed to be checked in the water glass. They know, too, that dirty valves leading to the water glass may prevent a true measure of the amount of water in the boiler, and the good custodian tries these cocks several times each day. The custodian also probably knows that if too much water is put in the boiler, it will result in expensive operation and if too little water is retained in the boiler, the crown sheet may become dry and explode when water is thrown on it. Most boilers are set so that 1/3 to 3/4 glass of water gives the best results. If a boiler is properly set and the heating plant is correctly installed, there will not be a great amount of water loss from the system. If there is a loss of water, fresh water should be added as frequently as needed to maintain the correct water level. A few plants drain the condensed steam from all or part of the building into the sewer. It seems doubtful that this wastage can be justified.

Pop or safety valves protect boilers from high pressures. The valve, whether a spring or a weight valve, should be set at the lowest pressure practical as a maximum for the boiler. Test this valve daily. If it is a spring valve, test it by pulling on this wire attached to the lever or trigger; if a weight pop valve, test by lifting the weight lever slightly.

Boilers are equipped with a soft plug in the top of the crown sheet.

The soft plug serves the boiler as an electric fuse serves an electric line. It is a weak point that will give way thus protecting the rest of the boiler. If the boiler is free from scale, a soft plug may offer full protection against explosions resulting from low water level. If the boiler is permitted to scale, the soft plug may be coated until it will not affect the boiler. If water does get below the safe level, shut off the burner and let the boiler cool down before new water is added.

Air is admitted to the fire through a special secondary device. If the quantity of air admitted is too great, the gases will be cooled below the ignition point and will not burn.

Boilers are also equipped with check valves in the return mains and in the water lines to prevent the pressure of the boiler from blowing back through these lines. If the water is dirty, sediment may collect in the check valves, preventing their working as they should. Check valves have caps which may be taken off to facilitate cleaning.

CHAPTER V
FUELS AND COMBUSTION

68/69

CHAPTER V

FUELS AND COMBUSTION

The principle fuel used to heat Florida school buildings are gas, oil and electricity. These fuels vary in quality, cost and abundance in different localities. The methods of firing furnaces will depend much upon the type of fuel used. The furnace should be the type that is adapted to use the fuel commonly used in the region.

GAS

Gas has increased in popularity for heating homes, schools and factories and has to some extent replaced oil for heating Florida schools. Since gas feeds automatically into the burner of the furnace, eliminating storage, and since it burns without the residue or ash common to coal, wood and oil, it has found ready acceptance in schools. There are a number of gaseous fuels, however, the only one used extensively in schools is natural gas.

Natural gas comes close to being the ideal fuel because it is free from non-combustible gas or ash. Natural gas is found under pressure up to 2,000 psi. in porous rocks and shale formations or cavities. It is found in more than 30 states and is transported by an extensive network of pipes to nearly every state. It is 55% to 95% methane, with small quantities of other hydrocarbons. In its natural state it is colorless and odorless, but as a safety factor to detect fuel leaks, odor is mixed with it. Natural gas may be classified as wet or dry, depending upon the amount of hydrocarbons. Wet natural gas has more hydrocarbons than dry natural gas. The heating value of natural gas is 950 to 1150 BTU per cubic foot. Oil is

often used as a standby fuel with natural gas in case of gas-line failure or low pressure in the line due to excessive cold-weather demands for gas.

Manufactured gases are not commonly used for heating schools. These gases are blast furnace gas, sewage gas, coal gas, coke gas, and others. Their heating range runs from 500 to 600 BTU's per cubic foot.

Liquified petroleum or bottled gases are occasionally used in heating individual classrooms, or one-room schools far from a natural gas pipe line. These gases, butane and propane, are made as by-products of gasoline manufacture. Both have high heating values, and since they are easily liquified at low pressure, they are often referred to as LP gases. Butane has a high heat value - 3200 BTU per cubic foot - while propane's heat value is 2500 BTU.

FUEL OILS

A tremendous growth has occurred within the last 20 years in the use of fuel oils in our homes, schools and factories. In many areas, gas and fuel oil furnaces have completely replaced coal fired furnaces. This is especially true in the State of Florida. Today, very few schools, if any, are still using coal fired furnaces. Fuel oil is a combustible liquid which is removed from the earth as petroleum. Geologists theorize that the decomposition of minute marine growths plus vegetable matter forms the oil that lies trapped in pools between layers of the earth's crust. Crude oil, as the petroleum is called when extracted from the earth, consists of 83% to 87% carbon and 10% to 14% hydrogen plus some traces of oxygen, nitrogen and sulfur.

Crude oil is removed from the oil wells to refinery mainly by pipe lines and tanker. In the refining process, which employes various temperature and pressure processes, the valuable products such as naphtha, gasoline, kerosene, gas oil, asphalts, etc., are extracted by distillation and cracking.

Fuel oils are the petroleum products from which the most volatile elements, such as the naphthas and gasolines, have been removed. Heavy fuel oils are those with 86% carbon and 11% hydrogen; lighter fuel oils are those with 84% carbon and 13% hydrogen.

FUEL OIL CLASSIFICATION

There are various ways by which fuel oils are classified. A common but very unsatisfactory method is by gravity as measured by a hydrometer. Specific gravity in degrees API (American Petroleum Institute) was found by dividing 141.5 by specific gravity at 60° F. and subtracting 131.5 from this answer. Gravity in degrees Baume is found in the same way, but specific gravity is divided into 140 and 130 is subtracted.

A much more widely accepted method is the one established by the United States Department of Commerce. Its classifications are:

Grade 1 - A light domestic oil (distillate) for use in burners requiring a volatile fuel with a minimum flash point of 100° F.
(or 38°-40° Baume).

Grade 2 - A medium domestic oil (distillate) for use in burners requiring a moderately volatile fuel with a flash point of 100° F.
(or 34°-36° Baume).

Grade 4 - A light industrial oil for use in burners requiring low viscosity with a flash point of 120° F. and requiring no preheating
(24°-26° Baume).

Grade 5 - A medium industrial oil for burners requiring a medium viscosity fuel with a flash point of 130° F. and requiring preheating
(or 18°-22° Baume).

Grade 6 - A heavy industrial oil with a flash point of 150° F
(or 14°-16° Baume). Because of its high viscosity, it
must be preheated before it is burned.

Viscosity and Pour points. This is the relative ease or difficulty
with which an oil flows. It is measured by the time in seconds it takes
a certain amount of oil to flow through a standard sized hole in a device
called a viscosimeter. The two used in the United States are Saybolt
Universal and Saybolt Furol viscosimeters. Viscosity indicates how oil
behaves when it is pumped. The pour point is the lowest temperature at
which an oil flows. Lighter oils will flow at lower temperatures than
heavy oils.

Flash and Fire Points. The flash point of an oil is the temperature
at which it will give off vapors which will ignite with a pop but not keep
burning when they are brought in contact with a flame. It is desirable to
know the temperature to which an oil may be raised before its vapors become
explosive. In preheating oils, the oil temperature must be kept 10° F.,
or more, below this flash point.

The fire point is the temperature at which an oil gives off vapors which,
when ignited, will continue burning. The fire point helps determine the
burning properties of oil, and also help determine if all the fuel is being
burned.

COMBUSTION

Combustion is the chemical combination of substances with oxygen, which
releases heat. It is oxidation. Rapid oxidation or combustion requires at
least three conditions for completion: (1) it is necessary to have a combustible
material or fuel; (2) enough oxygen must be supplied to combine with the fuel;
and (3) heat is needed to begin the process of oxidation.

During the oxidizing process, the oxygen of the air, combines with the gas, oil, etc., and passes off as carbon dioxide (CO₂) or carbon monoxide (CO). The energy of the fuel is rapidly released as heat. Some things burn more readily than others, but nothing burns until it comes in contact with oxygen. Vaporous gasoline mixes thoroughly with air and burns with an explosion. Natural gas is mixed with air to produce an inflammable mixture at the heating nozzle. Fuel oil, on the other hand, is a heavy liquid and is vaporized so that it will mix rapidly with air.

Fuel will not burn without oxygen. Each atom of carbon in the fuel must have two atoms of oxygen united with it at the ignition temperature in order that it may be completely burned. Air is 79% nitrogen and 21% oxygen by volume. The nitrogen of the air is of no use in combustion. As each particle of carbon must be brought into contact with the oxygen before it will burn, considerable air must be supplied in order to get complete combustion. The perfect air mixture for methane gas (the major element of natural gas) is one pound of methane gas to 17 pounds of air. The amount of air required varies with different kinds of fuel. However, the perfect ratio is seldom reached and so variations from the perfect air-fuel mixture must be made. In practice, a fuel may take 50 to 100% more air than the theoretically perfect mixture, since the air and gas streams must be brought together and heated somehow to start and maintain ignition. An ineffective method of mixing will effect the completeness of combustion: if too little air is supplied, only one atom of oxygen unites with each atom of carbon to form CO (carbon monoxide) instead of CO₂ (carbon dioxide). The CO passes up the chimney unburned, and considerable fuel is wasted. Too much air is not desirable either. Air is generally supplied to the combustion reaction in two ways: (1) primary air is introduced with the fuel, and (2) the secondary air is supplied to the flames coming off the fuels.

The combustible gas in a proper mixture of air needs the third element, heat, to produce combustion. The lowest temperature at which instantaneous combustion takes place is the ignition temperature. This is the temperature at which a fuel begins to burn.

The custodian who knows his fuel can learn to regulate his fire by the appearance and nature of the flame. An extremely blue flame indicates too strong an air mixture in comparison to a bright yellow flame indicating too little air for the fuel being consumed. This may require regulation of air entering the burner or of the secondary air that passes into the burner in order to burn the volatile gases and the carbon monoxide. The wise custodian will ask the gas company for a flue-gas analysis for gas fired furnaces. This will tell him if he is getting the proper combustion. Visible smoke over a flame may mean that some of the carbon and other solids are not being burned. With gas and fuel oil, too rich a mixture causes poor heat yield and too lean a mixture does the same.

By this time, the custodian will realize that fuel, air and temperature are useless for heating purposes unless their heat can be harnessed. Here is the place to consider the furnace with its burners and fire box, the boiler and its flues to absorb the heat that is produced. Two basic types of burners get the fuel in position to be burned.

In suspension or burner firing, the proper proportions of air and gas are combined to produce a combustible mixture. Burners for oil and coal on the other hand, must prepare the fuel as well as mix it and this requires fuel bed firing. Liquid oil is sprayed to a vapor and coal is heated. Within the combustion chamber, the fuel must be mixed with air and ignited, and the resulting reactions between fuel and oxygen carried to a finish.

There are three primary fuel sources in use in heating modern schools; gas, oil, and coal. In Florida, the primary fuel sources are gas and oil.

Burning gas

Even though it appears that gas is ready for combustion, the proportioning mixing and burning of gas can be handled in several different ways. There are several different kinds of burners which are described below:

Low pressure or atmospheric burners. These burners operate with natural gas at a pressure of from 1/8 to 4 psi. They are used for domestic heating and burn with a blue luminous flame. Multi-jet construction provides the maximum mixing of gas and air at the available pressure. Jets bring small streams of natural gas to the discharge opening in the burner in front of the firing chamber. The furnace draft causes air to flow around the jets, and the gas-air pressure is burned as it enters the furnace. Dampers help control the air supply.

High pressure burners. Because pipe lines carry gas at fairly high pressures, larger gas installations use burners operating under pressures of from 2 to 25 psi. Since gas-line pressures vary considerably, from 30 to 50 psi, regulators are used to maintain uniform pressure at the burners.

High pressure gas burners are generally used for steam generation. There are four types of high pressure burners:

1. The Peabody gas ring has an annular manifold located between the air register and the furnace wall and surrounds the burner opening. A series of orifices drilled around the intersurface of this ring sprays gas at an angle across the air stream toward

the center of the burner opening. The gas-air mixture then enters the furnace through a curved throat opening, where it burns with a short transparent flame.

2. The center diffusion tube burner has the gas head with its orifices located in the center of the burner. It remains in this operating position at all times. In this burner, fuels can be burned either separately or simultaneously. The gas leaves the burner tip in the shape of a hollow cone and at a wide angle to the entering air. A diffuser plate assures steady and prompt ignition, together with the proper mixing of fuel and air for complete combustion. A flame of this type is short, intense, transparent and well distributed throughout the furnace. Oil may also be used in this burner.
3. A turbine gas burner uses revolving instead of fixed orifices. Gas pressure causes the burner to rotate at high speed, which mixes and proportions the gas to the air stream. These burners when properly operated and maintained have no visible flame and provide almost constant temperature throughout the furnace. When oil is used, the nozzle tip is moved forward through the hollow center, and low-pressure steam is used to make the nozzle rotate.
4. A tangential burner uses pulverized coal as its alternate fuel. This burner has a wide, flat-wedged shaped tip containing a number of orifices. Air is supplied by a forced-draft fan. Ignition takes place at the burner tip. Combustion is rapid, because of high turbulence of air.

Gas safety precautions. For the safety of the building and

the occupants there should be a gas shut-off outside the building, as well as an automatic shut-off in case of line failure to guard against explosions. If there is a strong smell of gas in the furnace room, do not carry lighted tobacco into the room. Air out the room before checking for the gas leak. In case of doubt, call the gas company at once.

BURNING OIL

Oil burners must proportion the fuel and air, as well as mixing them. This may be done by atomizing the oil within the burner so burning can take place within the combustion chamber. The atomization may be affected in one of three ways:

1. Using steam or air under pressure to break oil into droplets.
2. Forcing oil under pressure through a nozzle.
3. Tearing an oil film into droplets by centrifugal force.

"Three T's" are important in oil combustion: Time, Temperature and Turbulence. Time is required to pump oil from storage to the burner, to ignite it, to burn it, and to pass through the stack in a gaseous state. Temperature refers to the temperature of the oil, the temperature of the ignition firebox, etc. Turbulence is the action caused by the burner in breaking up oil and the distribution of it in a uniformly sized flame to produce more uniform mixture conditions over the combustion zone.

For good burner maintenance, use only uniformly free-flowing oil which is clear of sediment. Burners should be kept in good condition, free from carbon build-up. In rotary-cup burners, worn rims cause poor atomization. When shutting down a rotary burner, place the cups with a flame shield. Worn nozzles should be replaced in the mechanical burners.

Oil is clean in both handling and burning, is uniform in performance, more easily maintained, and the cost is usually lower than coal. Maintenance costs are considerably lower due to the fact that the fire burns in suspension, thereby reducing the cost of brick and grate replacement. The dirt and labor of handling ashes are eliminated. Fuel can generally be stored underground outside the building giving additional space inside for other purposes.

There are many brands of oil burners on the market, but only a few differences in the principles involved. Here is a description of those in common use:

The low-pressure atomizing burner is very simple in construction, consisting only of a piece of pipe which carries the oil to the atomizing tip. There the oil is mixed with air which creates a turbulent action, breaking the oil into a fine spray in the combustion chamber where it is burned in a conical or flat flame, the shape of the flame being governed by the shape of the burner orifice. This burner is used in kilns, small heat treating furnaces, under melting pots and occasionally in small boilers. Original cost is low and maintenance is negligible. Its use is more or less limited to lighter fuels. Operating pressures are two to seven pounds. They are designed to use No. 1 and No. 2 fuel oil.

The construction of the high-pressure atomizing burner is somewhat similar to the low-pressure type. This burner can handle a much heavier oil and it is even simpler in design and construction than the low pressure burner. An air compressor is a necessary accessory, which adds to the total cost, and the atomizing cost per 1,000 gallons of oil is higher in the long run. The No. 1 and No. 2 oil, which is generally used is atomized at 100 psi. Ignition is by electric spark.

The high-pressure steam-atomizing burner is constructed like the burners just discussed, steam being introduced, instead of air, as an atomizing medium. The chief difference lies in the mixing chamber (the chamber where the oil and steam meet prior to being introduced into the combustion chamber). Two kinds of chambers are used, one an outside mixer, and the other an inside mixer. The inside principle affords better control. The outside, however, is somewhat simpler and the nozzle tip can be cleaned more easily. Steam is introduced at various temperatures according to the viscosity of the oil. Steam must be dry, moisture coming in contact with the oil will create an uneven, pulsating flame which wastes oil. This burner will enable you to burn any fuel which can be pumped, as for example, tar. Cost of this equipment is low but the cost of steam production, loss of water from the boiler feed, etc., must be included when computing operating costs. Nozzles are extremely sensitive to pressure changes, carbon formation, dirt, etc. A minimum of $2\frac{1}{2}$ pounds steam to 1 gallon of fuel is required.

The fire is started by means of a waste torch on the end of an iron rod. Before starting a fire, open all the hampers and doors to allow any accumulated gases to escape. The steam line should be blown also before starting the fire. Always open the steam valve before opening the oil valves. An efficient fire produces just a slight haze from the top of the stack. The burner nozzle should be removed and cleaned periodically. A manually operated oil burner should be watched constantly as the fire may go out any time due to water in the oil, a dirty nozzle, or insufficient steam pressure.

There is the mechanical pressure atomizing burner, also simple in construction and low in maintenance cost. The oil passes through a tube under pressure and then to an atomizing disk which breaks the oil into minute particles, and from there to a tip made of a heat resisting alloy where it is burned. This burner is capable of handling heavier oils and is generally used in large power plant installations of 300 H.P. upwards, where operations are fairly uniform. After around eight hours of constant operation, it is generally necessary to change burners and to clean the nozzle and tip. Due to its original low cost, it is possible to have three or more extra burners on hand. The atomizing cost is fairly low.

The horizontal rotary burner appears to be more complicated and has considerably more parts than those previously discussed. We might also add that the original cost is considerably higher. However, its flexibility is practically unlimited and it is highly efficient. Despite the fact that it requires more machinery, it is easily adjusted and maintenance cost is low. It is a self-contained, compact integral unit that can be installed at the fire box of any boiler and is hinged to the boiler, making it a simple matter to inspect the burning end. The oil is introduced through a hollow shaft passing through a cup, which revolves at high speed, (approximately 3,450 RPM), causing the oil to atomize. Air is mixed in at this same point, creating a turbulence and a flame that can be made short, bushy or straight shot, by a very simple adjustment. It can be operated manually, automatically, or semi-automatically as desired. When operated automatically, uniform temperatures can be maintained throughout the building by means of a room or building thermostat. Ignition is by a combination of an electric spark and gas flame. It has a wide range of capacity in any

given size and can utilize heavier oils. This burner is widely used in public buildings, hospitals, institutions, industrial plants, etc.

In the vaporizing burner, fuel oil is ignited either manually or electrically and is then vaporized. Openings in the side walls of the burner admit the primary air which forms a rich mixture of air and oil vapor in the burner. Secondary air is then admitted to complete the combustion. Fuel oil is fed by gravity and the flow is either ON at the rated capacity or OFF at pilot flow as regulated by the thermostat. Most vaporizing burners are limited to one gallon of fuel oil per hour. Vaporizing burners are generally used for water heaters, space heaters, and furnaces.

AUTOMATIC CONTROLS

These controls have become an essential part of our heating, ventilating and air-conditioning systems. Automatic controls respond to variations in temperature, relative humidity, and pressure. They operate individually or in sequence to provide the desired conditions throughout the system. The control system consists of:

1. A controller which measures such variables as temperature, humidity, or pressure through thermostats, humidistats, and pressure controllers.
2. A controlled device which reacts to the impulse received from the controller by regulating a valve, a damper, or a motor.
3. A controlled agent, which does what the controlled device directs. Such an agent may supply more gas, steam, or water.

In addition to these items, most control systems have auxiliary apparatus such as switches, relays, gauges, pilot light and other

indicators for observing the operation of the system. The controls for automatic fuel burning equipment are:

1. Operating controls, which start and stop the burner.
2. Limit controls which guard against unsafe temperature, pressure, or water level, to assure proper burner operation.
3. Primary controls which provide for safe, start and operating procedure of the burners.

Since most automatic controls are delicate pieces of equipment, only an experienced custodian should attempt to adjust them.

CHAPTER VI
DAILY PROCEDURES

CHAPTER VI

DAILY PROCEDURES

Each day during the heating season, certain steps must be taken to insure that you have safe, efficient operation of your heating plant. Before the boiler or heater is started each day, the following steps should be taken to insure a safe, proper start:

1. Check the fuel supply. Too often complaints reported to the maintenance department for correction stem from the failure to check this one item. You cannot expect any furnace to fire which does not have fuel.
2. Check the water level in your boiler. Do not attempt to start if the water level is too low or too high. If it is too low; bring the level up to the proper level. In no case, should you fire a boiler which does not have sufficient water. If it is too high, check your expansion tank. If the indicator shows that it also is full, then you possibly have an air leak in the expansion system, and/or possibly an automatic water make-up valve malfunction.
3. Check the fire box. Make sure that it is clear of all trash and is not flooded with fuel or have other obstructions in it. Do not fire a furnace until you have checked these three items.

Unless the custodian is especially trained, he should refrain from handling the heating controls, as they are very delicate and easily damaged. In most cases, it is a good policy for the Board to have a contract with a control company manufacturer to regularly inspect and service the schools heating controls or have especially trained maintenance men to make these

adjustments. In no case is the custodian to attempt to adjust heating controls.

BLOWING DOWN A LOW PRESSURE BOILER

This job must be started while the boiler is in operation. No header valve or return lines are to be closed. The operation of the entire heating system must not be disturbed. Take the following steps:

1. Check the water level in the boiler.
2. Add fresh water very slowly as required.
3. If the water in the boiler has reached the maximum level and the steam gauge is at operating pressure, open blow-off cocks wide.
4. When the water in the boiler has reached one inch below lowest safe water level, close blow-off cock.
5. Refill boiler to operating level.
6. Check leakage from blow-off pipe or valve, if possible. This may be done by checking water level in the boiler at night and comparing it the following morning.

This process blows off or forces from the boiler all foreign matter such as, scale, sediment, rust, etc., which will hinder its operation.

LOCATING BOILER TROUBLE

A complaint regarding boiler operations generally will be found to be due to one of the following:

1. The boiler fails to deliver enough heat. The cause of this condition may be: (a) poor draft, (b) poor fuel, (c) inferior attention or firing, (d) boiler too small, (e) improper piping, (f) improper arrangement of sections, (g) heating surfaces covered with soot, (h) insufficient radiation installed.

2. The water line is unsteady. The cause of this condition may be:
(a) grease and dirt in boiler, (b) water column connected to a very active section and, therefore, now showing actual water level in the boiler, (c) boiler operating at excess output.
3. Water disappears from the gauge glass. This may be caused by: (a) priming due to grease and dirt in the boiler, (b) too great pressure difference between supply and return piping preventing return of condensation, (c) valve closed in the return line, (d) connection of the bottom of the water column into a very active section or thin waterway, (e) improper connection between boilers in battery permitting boiler with excess pressure to push returning condensation into boiler with lower pressure.
4. Water is carried over into steam main. This may be caused by: (a) grease and dirt in boiler, (b) insufficient steam dome or too small steam liberating area, (c) outlet connections of too small area, (d) excessive rate of output, (e) water level carried higher than specified.
5. Boiler is slow in response to operation of dampers. This may be due to: (a) poor draft resulting from air leaks into the chimney or breaching, (b) inferior fuel, (c) inferior attention, (d) boiler too small for the load.
6. Boiler requires too frequent of cleaning flues. This may be due to:
(a) poor draft, (b) smoky combustion, (c) too slow a rate of combustion, (d) too much excess air in the fire box causing chilling of gases.
7. Boiler smokes through fire door. This may be due to: (a) defective draft in chimney or incorrect setting of dampers, (b) air leaks into boiler or breaching, (c) gas outlet from fire box plugged with fuel, (d) dirty or clogged flues, (e) improper reduction in breaching size.
8. Low carbon dioxide. On oil-burning boilers, this may be due to:
(a) improper adjustment of the burners, (b) leakage through the boiler setting, (c) improper fire caused by a fouled nozzle, (d) an insuffi-

cient quantity of oil being burned.

ELIMINATION OF WATER-HAMMER FROM THE HEATING SYSTEM

The pounding noise which is sometimes heard in the heating system is called water-hammer. When steam comes in contact with water which has become trapped in low places in pipes or radiators, some of it is condensed in such a way as to form a partial vacuum. This starts the water oscillating back and forth and sets up a vibration in the system which may cause serious damage. Sagged pipelines, defective or leaking steam traps, radiators low on one end, and water too high in the boiler are frequent causes of water hammer. Leaky joints are the most common result, but in extreme cases lines may be broken or fittings ruptured.

The following suggestions may help you eliminate water hammer:

1. Locate the point where the water hammer is the loudest.
2. If it is in the piping, test for the low point with spirit level.
Adjust hangers so that the pocket will be removed and water can drain back into the boiler.
3. If the trouble is found to be in one end of the radiator, level the radiator by placing a block under the end.
4. If the noise appears to be in a radiator trap, cut steam off the radiator and clean the trap. If necessary, replace either the entire trap or the damaged parts.

THINGS TO REMEMBER WHEN OPERATING A BOILER

1. See that the valves at the top and bottom of the water gauge are always open and operating.
2. See that the steam gauge cock is open.

3. The pet cocks on the water column are for testing the accuracy of the gauge glass. Use them.
4. Valves to the heating system, both the supply and the return, must be wide open.
5. In the brick set boiler, all spaces between the boiler and the brick must be clear of false work, mortar, brick and rubbish.
6. The breaching must be tight in the boiler wall and chimney. See that it does not extend into the boiler or into the stack and cut off the draft.
7. Do not carry more steam than is necessary to heat the building.
8. Unnecessary pressure wastes fuel.
9. Shift weights in regulator lever to change steam pressure.
10. Brush out fire tubes as often as necessary to keep them clean.
11. At the end of the heating season clean and inspect the boiler carefully so that it will be in condition for the next heating season.

ECONOMICS IN HEATING

Conservation of room heat

This involves regulating not only the source of heat, but also windows and doors to make sure that heat is not wasted. If no heat escaped, the heating plant could be shut down after the building had once warmed. Heating and ventilation are inseparably associated, but they are in opposition. The more ventilation, the greater is the amount of additional heat need. Here are some ways to conserve heat with little or no outlay of money.

1. When the room become uncomfortably warm, turn down radiator valves

instead of opening windows especially from the top. This economy is particularly applicable when thermostatic controls are not provided.

2. Windows should be kept well puttied. A surprising amount of air will come in around poorly puttied glass.
3. Occasionally children may use leeward entrances when the wind is strong.
4. The amount of cold air brought in from the outside should not be in excess of the amount needed.
5. If the window shades are lowered when the room is not in use, heat will be conserved. All window shades in the room should be raised or lowered to a uniform height.

In carrying out the fourth suggestion, it is obvious that when mechanical ventilation is used, the outdoor intakes should not be opened until the school building is occupied and the intakes should be immediately closed after the close of school.

Prevention of Fuel Wastes

The most common causes of fuel wastes are:

1. Loss in handling, both before delivery and later.
2. Gases and carbon passing up the chimney as smoke, due to incomplete combustion.
3. Heat lost through radiation from the boiler. Insulation will reduce this loss by as much as 80%.
4. Soot in the boiler, which cuts down fuel efficiency, since it acts as an insulator.
5. Radiation. Savings of fuel can be obtained by using the right material to paint the radiator. Gold, silver, or bronze will decrease radiation

25%; aluminum will decrease radiation 15%; flat wall paint will decrease radiation 7%; however enamel, will increase radiation 5%.

6. Scale, which lowers efficiency; Steel conducts fire heat five times as rapidly as lime scale. If necessary, water should be treated before use in the heating system to prevent formation of scale.
7. Inefficiency of boilers due to lack of repairs, they should be kept in good condition at all times.
8. Excess air. This perhaps is the greatest single cause of fuel loss. About 40% excess air is sufficient for the complete combustion of average fuels. Excess air may be due to one or more of the following causes: (a) fire doors may be fitted poorly; (b) fire doors may be kept open too much; (c) air may be leaking at dampers or breaching; (d) boiler settings may be badly cracked; (e) bricks may be porous; (f) chimneys may be cracked or pitted; (g) drafts may not be properly adjusted.
9. Improper draft, which results in a lack of combustion, is very important as a source of waste. It is important that the chimney be properly proportioned. There is a tendency for architects to specify a chimney which is too low. This fits in better with the general appearance of the building, but it is an important cause of heat loss. Plenty of draft is essential to the proper combustion of fuel. This is not as applicable where gas and oil are the fuels used. Check chimney dimensions by referring to the catalog of the company which manufactures the boiler that is in use.
10. Rooms may be overheated.

11. There may be leaks in water or steam lines.
12. The combustion chamber may be too small or poorly shaped.
13. Unused rooms may be heated.
14. Heat may be lost from uncovered steam lines.
15. Excessive evening meetings may be held.
16. Leaking steam traps.

Items two, seven and eight may be remedied in part by proper firing.

Fire the boiler according to directions given by the manufacturer or by some reliable engineer.

Since soot in the boiler cuts down fuel efficiency, the heating surfaces should be kept clean by brushing and scraping. Flues of solid fuel boilers should be cleaned often enough to keep the surfaces free from soot or ash. Gas boiler flues and burners should be cleaned at least once a year. Oil burning boiler flues should be examined periodically to determine when cleaning is necessary.

Testing Safety Valves and Low Water Cut-outs

The only positive method of testing a low water cut-out is by duplicating an actual low water condition. This is done by draining the boiler slowly while under pressure. Draining is done through the boiler blowdown line. Many heating boilers are not provided with facilities for proper draining, this is an important consideration.

Many operators mistakenly feel that draining the float chamber of the cut-out is the proper test. But this particular drain line is only provided for blowing out sediment that may collect in the float chamber. In most cases the float will drop when this drain is opened, due to the sudden rush of water from the float chamber. Every boiler inspector can tell you

of numerous experiences of draining the float chamber and having the cut-out perform satisfactorily. But when proper testing is done by draining the boiler, the cut-out fails to function.

Failure of safety valves to work is usually due to a buildup of foreign deposits that result in "freezing". This is an indication that the valve has not been regularly tested or examined. One of the greatest causes of foreign deposit buildup is a "weeping" or leaking condition. The only way to be sure that a valve is in proper operating condition is to setup and adhere to a regular program of testing valves by hand while the boiler is under pressure. Also, any weeping or leaking valves should be immediately replaced or repaired. This is important.

Low pressure (15 psi) safety valves should be lifted at least once a month while the boiler is under steam pressure. The valves should be fully opened and the trylever released so the valve will snap closed. For boilers operating between 16 and 226 psi the safety valve should be tested weekly by lifting the valves by hand.

Boiler Compounds

In certain localities the water will pit the boiler within a short time. Rain water is particulatily bad for most boilers, it is desirable to have the water analyzed to determine if an harmful effect to the boiler may result from use of the water available. It may be possible to test the water and provide treatment with boiler compounds which will prevent pitting and corrosion. Almost all water needs some treatment. Boiler compounds may be purchased in either liquid or powder form. Properly used they prevent and eliminate rust, congestion, corrosion and soiling in hot water supply systems for kitchens, shower and other areas and the heating system. They

stop pitting and galvanic action not only of the boiler but also of the entire heating system. From ten to twenty five percent of fuel cost may be saved as well as the time and materials lost in boiler replacements.

CHAPTER VII

BOILER CARE

CHAPTER VII

BOILER CARE

Cleaning the Boiler

Soot acculamation on the heating surfaces and gas passages prevent adequate draft. Soot and scale accumulation on boiler tube surfaces lowers the rate of heat transfer from the gases to the water for steam generation. Three sixteenths of an inch of soot is equal in insulating effect to one inch of asbestos. Soot and scale are good insulators thereby lowering the efficiency of heat exchange from the gases to the water of the boiler units. This hastens the deterioration of metal surfaces by the action of chemicals and heat. Therefore the surfaces should be cleaned of soot and scale accumulation periodically. Complete combustion and maintenance of combustion until gases come in contact with the heating surfaces are essential to prevent soot formation. Minerals in the boiler water should be removed by treatment with chemicals, heating, and filtering. The boiler may be removed from service and the scale removed mechanically, or with chemicals, as the condition of the surfaces indicate.

Mechanical cleaners are used to remove scale from the boiler and the water wall tubes. Cutters powered by small motors are passed through the tubes. A hose connected to one end of the motor supplies steam, air or water to the motor, and also enables the custodian to feed the unit through the tube and withdraw it when the cleaning is completed. In using these mechanical cutters, take care that the cutters cut only the scale and not the metal of the tubes. Use motors of the proper size. Bent tube boilers are, of course, harder to clean than straight tube boilers. At best

mechanical cleaning is difficult and tedious.

Chemical cleaners have proved very successful in cleaning boilers. They are very fast compared to mechanical cleaners. Take a sample of the tube scale and send it to a custodial supply house or a chemical company which specializes in water treatment for boilers; ask them to analyze it and help you choose the correct mixture of chemicals - an accelerator to dissolve the scale, and an inhibitor to protect the metal.

Some of the scale can be removed by boiling out with an alkaline solution similar to that for removing oils and grease. Other scale requires an acid solution. Hydrochloric acid is often used with an inhibitor. Acid cleaning requires a circulating pump and solution tanks, and temporary piping. After the acid solution has been circulated through the boiler unit at the proper temperature by means of the circulating pump, it is drained off, and the boiler surfaces are rinsed with an alkaline solution to neutralize the remaining acid.

Foaming is caused by dirt or oil in the water, an overdose of boiler compound, water carried at too high a level in the boiler, or too high an overload on the boiler. In case of heavy foaming, there should be a complete change of the source of supply and treatment of the water, adequate blowing-off of the surface, and lower blow-off openings. The entire interior surface may have to be given a thorough cleaning to eliminate the source of foaming, and to eliminate all the oils and greases from the surface of the water end. If you find that your boiler is foaming badly, it may be necessary to drop the fire immediately so that all of the water will not leave the boiler.

Broken Tubes

If a tube breaks on a low pressure system during operation, it is essential that this boiler be removed from service and that correct procedure applied during the separation for closing down of non-operating periods. After a boiler is removed from service, the punctured tube is removed and a new one installed.

Flue Care

Flues should be cleaned as frequently as needed. If the boiler is properly installed, flues may be cleaned with the long wire brush flue cleaner. If the flues have been permitted to cake with deposits, it will be necessary to use the flue scraper. Deposits in the flues retard the conduction of heat through the flue to the water, and thus increase fuel costs.

If the boiler room does not provide sufficient space for cleaning the flues, you may have to use a jointed or flexible rod. However, cleaning the flues at best is a dirty job and it is desirable to have ample room to do the work properly. Both sectional and steam boilers need flue cleaning frequently if coal is burned. Flues in high pressure boilers may be cleaned by blowing or by the use of a steam jet. Leaky flues may be plugged at each end to stop the leak temporarily. In attempting to replace the flues, be careful not to injure the plate in cutting out the old flue. The new flue should be cut to the right length, inserted, expanded and beaded.

Flue Gas Analysis

One of the most common heat losses is the loss of unburned flue gases up the chimney. Often this loss is greater than all others combined

(radiation, convection and conduction). To analyze these losses by carbon dioxide analysis, samples of flue gases are taken, with their representative temperatures. This enables the custodian to find out how much heat is lost up the chimney. There is a simple portable device which determines only the carbon dioxide in the flue gas. Since most custodians are not skilled engineers, the local fuel company can be asked to make this check, especially of gas and oil fired furnaces. Poor burning may be due to poor drafts, wrong mixture, plugged flues, or some other fault, and the fuel company will be able to make the necessary recommendations.

Oil in the Boiler

If oil is found in the boiler, be sure to remove it regardless of the time and labor required. Oil floating on the water will adhere to the shell at the water line. If a boiler is under heavy load and surging occurs, oil will also cling to the top row of tubes. Then the oil will loosen the protective scale and lay the metal bare for rapid oxidation, and the boiler will be damaged by pitting. There is also danger of burning or bagging the sheets if oil comes in contact with them.

The method recommended for removing oil is as follows: Remove manhole, raise water level well above the normal position according to the size and condition of the boiler, put in soda ash, start a slow fire and bring the water to a boil for about one hour. Allow to cool, then drain boiler and flush with a hose. Oil adhering to the shell and braces along the water line may be removed by scraping followed by a steel brushing.

Electrolysis

Always be on the alert for electrolysis and stop its action as soon as possible by suspending a zinc bar in the water between the tubes. Then make

every effort to find the cause of the trouble. Electrolysis can be detected by the appearance of the blisters formed. Blisters formed by electrolysis, when broken, will be bright underneath and not rusty like those formed by ordinary oxidation. This electric action can ruin a boiler in a surprisingly short time.

Mineral Coating on Plates and Tubes

There should be a light coat of scale or mineral deposit on the plates and tubes which serves as a protective agent for the boiler. However, if it becomes too thick, the same scale may act as an insulator and result in the burning and blistering of the plates and tubes. In cases where the coating is insufficient, it may be increased by feeding the boiler in the following manner. Place the quantity of lime desired in a large tub or pail filled full of hot water. Allow this to settle and become clean, then siphon off the clear liquid and introduce it into the boiler. Never under any circumstances, introduce lime in its solid form into a boiler.

Manholes and Gaskets

Before removing a manhole or handhole to replace a gasket, be sure to mark the position and ends of the yokes, bolts, and plate. When a new gasket has been fitted, replace the parts in the same position as nearly as possible. Often the yokes are sprung or the bolts worn and a change in their relative position may produce leaks that are hard to control without strain or breakage. Clean the surface of the manhole and coat the graphite before replacing the gasket. All handholes and manholes should be re-tightened after the boiler has been in service a few days.

Preparing Boilers for the Summer Layup

If a boiler is to be out of service for a month or more it should be emptied, opened and cleaned internally and externally. The boiler, and breeching, which includes the steel parts of the furnace, deteriorates much more rapidly when the boiler is not in operation than when it is. Nearly all fuels contains some sulfur, sulfur combines with moisture in the presence of air to form sulphurous acid, which corrodes metal.

To prepare a boiler for a complete cleaning, remove the non-combustible materials from the furnace and ash pits, and clean the firebox and flues. Then wash the boiler. Be sure that you have allowed adequate cooling time before running water into the interior spaces of the boiler, or the sediment, scale, and sludge will bake on the surface requiring considerable labor to remove it. If you can't wash out the inside right away, fill the boiler with water while it is still warm. If it is filled to the top and the water is heated to about 180 degrees F. and then allowed to cool, the boiler will not corrode or rust. However, if space is left at the top, the combination of air, metal, and water will rust it at the water line.

After the boiler has been emptied, the handhole and manhole cover should be removed, and the entire interior of the boiler should be washed out with a hose with as much pressure as possible. Be sure to hit all the spots of scale and mud on the heating surface.

Never crawl into a boiler unless there is someone on the outside to help you. It is unwise to take an extension cord into a boiler; use a flashlight or fasten a light on the outside in such a way that it will provide adequate light.

If you plan to leave a boiler full of water, clean it on the inside first

and outside last. If it is going to stand dry, clean the outside first and then the inside.

The Wet Method

The Pacific Boiler Company recommends that dirty water be drawn off the boiler at the end of the heating season, which should thus remove all sludge and corrosive material, and new water then be added to the top of the guage glass. This means that a boiler is not completely drained off each year. It is wise to heat the new water to about 180 degrees F. to drive off the dissolved oxygen and carbon dioxide which causes corrosion. New boiler compounds should be added at this time.

The Dry Method

The Kewanee Boiler Company, on the other hand, recommends a complete internal and external cleaning of the boiler in preparation for the summer layup. They further recommend keeping the boiler dry over the summer if the climate is dry enough to warrant this. Shallow pans of quicklime or silica gel placed in the boiler will absorb most of the moisture from the air and help prevent corrosion. Keep the doors tightly closed.

Boiler rooms should always be kept dry and well ventilated. It is highly recommended that you do not use a boiler for a paper or rubbish burner during the summer.

The inside as well as the outside of the breechings should be thoroughly cleaned and painted with asphalt paint. This paint is recommended because it is cheap, acid proof, and provides good protection against rust and corrosion. The fire side of the boiler should be oiled. Run an oil-saturated swab through the tubes. During this cleaning process, the steam guage should be removed and cleaned as well as the water guage glass. Glass that has been discolored

by the action of the water can be cleaned by filling it half full of vinegar, putting your fingers at each end, and running the vinegar back and forth. A mild solution of hydrochloric acid is also satisfactory.

As you clean a boiler, watch for signs of deterioration and weakness. Some of the more important conditions to watch for are: corrosion, bulging, distortion of boiler plates and tubes, leaky tubes and plates, leaky seams and rivets, blisters on the various surfaces, sagging tubes, exterior corrosion, embrittlement of the heavy scale, oil accumulation, and pitting. These conditions should be studied and remedied.

Discovering Boiler Troubles

Bagging is caused by overheating of the surfaces due to lack of water over tube surfaces. It is also caused by overheating of the metal as a result of scale, sediment, sludge, grease or oil accumulation on the metal surfaces which prevent the heat flows from the gases to the water of the boilers. The pressure forces the metal outward. The non-homogeneous construction of the material in the tube or plates and laminated conditions will cause bagging of the surfaces under operating conditions of the steam generators.

Blistering is caused by conditions similar to those of bagging, including lamination and non-homogeneous material of the boiler and the accumulation of oil and heavy scale on the metal surfaces of varying thickness and area.

Pitting is caused by corrosion, chemical action of the feed water, accumulation of oil of acid nature, and the non-homogeneous condition of the material of the tubes. To remedy bagging, blistering and pitting, remove the oil and scale accumulation, treat the feed water and metal surfaces, provide material suitable and adaptable to the water surfaces, change water supply

and apply correct operation procedures. Bags and blisters on the boiler surfaces can be heated and hammered back to original form.

Pitting is prevented by providing treatment of the water to neutralize corrosive elements; change of source of water supply; frequent blowing down of the boiler water; elimination of the cause of pitting as various materials of construction de-aeration of feed water to the boilers and addition of fresh water or make up supply of feed water to the boilers.

The causes of leaky tubes are scale and soot accumulations causing overheating; poor material and workmanship; expansion and contraction strains; low water; incorrect operating procedures; and corrosion of the surfaces.

CAST IRON BOILER MAINTENANCE

DURING the course of a normal heating season the average steam or hot water heating boiler is subjected to a wide range of expansion and contraction stresses due principally to the varying demands for heat and consequently an intermittent rate of firing.

From this it might be assumed that ordinary cast iron would not be well suited for heating boilers because it is a relatively brittle material that cracks rather easily. However, use of cast iron over a great many years has proven that it is a satisfactory material for low pressure heating boilers, provided the equipment is given a reasonable amount of care.

There is a strong inclination to forget about the heating plant when the weather becomes warm enough to shut down the boiler. The owner is likely to say to himself that there is no need to worry when the boiler isn't being used and that there will be plenty of time during the summer to check over the heating plant and determine if it is in satisfactory condition for the next heating season. But there are several good reasons why a complete check of the heating system is in order immediately at the end of the heating season. Deterioration of the boiler and system may be much more rapid during the idle period than when it is in service. Also, if there is not adequate provision for expansion between the sections serious damage may result while the boiler is idle or when it is started up in the fall. Moreover, any repairs necessary to place the heating system in proper operating condition for the next winter's use should not be put off or forgotten until cold weather arrives, as it may then be too late to make satisfactory repairs without unnecessary expense.

Corrosion

An accumulation of soot and ashes left in a boiler often results in rapid deterioration by corrosion. Most fuels contain, among other impurities, some sulphur, a certain percentage of which will remain in the soot and ashes which

accumulate on boiler surfaces. During idle periods the soot and ashes may become moist as a result of the boiler "sweating" or by absorption of moisture from damp air in the basement or the boiler room. Under such conditions the sulphur combines with the moisture to form sulphurous acid, resulting in serious corrosion of any metal surface with which it comes in contact, whether the surface be the boiler, stack, breeching or other duct work.

To prevent corrosion which may, in extreme cases, eat entirely through the breeching or other duct work in a single season, or damage the boiler itself, all metal surfaces should be thoroughly cleaned at the end of the heating season. The firebox, gas passages and the smoke pipe should be brushed out. Use of a wire brush and vacuum cleaner will help in doing a good job. By getting the unit clean, the chances of acids forming is greatly lessened and the boiler surfaces have a much better chance of staying dry. In cases where the basement or boiler room is quite damp during idle seasons, precautions should be taken to prevent corrosion by painting the boiler surfaces with a protective coating, or taking steps to remove the cause of the dampness.

Trash and debris should not be allowed to lie around the boiler. Such an accumulation may corrode the

Clean all boiler surfaces to protect against excessive corrosion during the idle season.

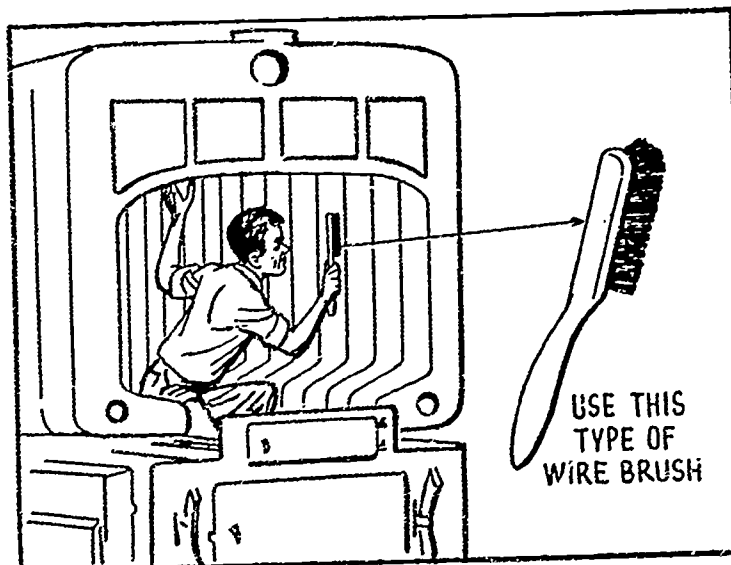

metal supports for the boiler to such an extent that the base may begin to give way, resulting in movement or shifting of the sections. If this occurs, leakage at the push-nipples and at pipe connections is very likely to develop.

Expansion Between Sections

After soot and ashes have been completely removed from boilers of the push-nipple type, a careful examination should be made to determine whether or not there is ample provision for expansion between the sections. Tie-rods may have been incorrectly installed so that they hold the sections too tightly together. Or there may be a serious build-up of rust growth between the sections. Either condition may result in cracking.

If the tie-rods of a push-nipple type boiler were installed properly, one of the following three alternate procedures was followed after the sections were assembled:

1. The solid nuts used on the tie-rods for drawing the sections together were backed off several turns to allow ample room for expansion; or
2. The solid nuts were used in conjunction with compression washers; or
3. Split nuts were used instead of solid nuts, which in turn, may have been used in conjunction with compression washers.

Any one of the above alternatives usually provide adequate allowance for expansion of the sections. Each boiler, as installed, should have been treated in one of these three ways. However, this practice is not followed in all cases as a few plumbers and heating engineers do not fully understand the seriousness of leaving the tie-rods tight on a boiler. In fact, many of them feel that the tie-rods are necessary to hold the boiler together.

The tie-rods on boilers of the push-nipple type are provided merely for convenience in assembling the sections and are not necessary to hold the boiler together. The rods could, in fact, be removed after correct assembly of the

sections and the boiler would be just as safe for operation as if the rods remained in place. The tapered design of the push-nipples, together with the ground surfaces of the nipples and the openings into which they fit, are such that when the sections of the boiler are properly drawn together by the tie-rods, the joints will remain tight in service even though the tie-rods are removed. They are left in the boiler merely for convenience in reassembling the sections in case repairs at a later date require their use.

When leakage is found at the nipples on a cast iron boiler, plumbers and heating contractors will frequently pull up on the tie-rods to correct this leakage without first checking to determine the cause. Where this practice is followed, the tie-rods should again be loosened after the leakage is stopped. If the leakage recurs it is probably evidence of rust growth or other foreign matter between the sections.

Rust growth between sections absorbs moisture from the air during the idle period, resulting in additional corrosion which often builds up until there is no more room for expansion. Then a further build-up of rust growth will exert great pressures tending to push the sections apart. If movement occurs, nipple leakage is very likely to develop, but if the sections are held

Check tie-rods on push-nipple type boilers to be sure there is provision for expansion of the sections.

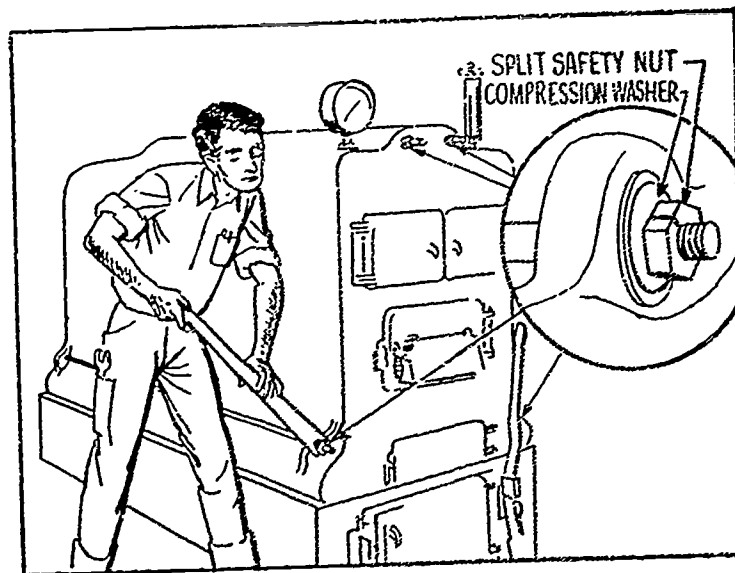

tightly together, cracking is certain to occur. To prevent such a condition a careful check for rust growth should be made at the end of the heating season or whenever it is suspected. If any is found, the boiler should be dismantled, thoroughly cleaned and then reassembled, repacking with insulating material between the sections. Taking care one of the three methods for providing expansion, mentioned above, is used. A less desirable method for removing rust growth is by scraping between the sections with a hack saw blade.

In any case, the tie-rods should be checked at the beginning of each idle period to make sure that they are loose and that there is ample provision for expansion of the sections.

Boilers of the header and screwed nipple type and some push-nipple type boilers are not subject to damage from rust growth between sections because of their design. At least one manufacturer provides short tie-rods extending only to adjoining sections and in this manner prevents the concentration of stress on the end sections which may result when full length tie-rods are used. Other manufacturers use sections so designed that the contact area with adjoining sections is small and any corrosion products formed will tend to slough off instead of accumulating.

Internal Cleaning

If, because of leakage from the return lines or some part of the system, it has been necessary to add considerable makeup water to the boiler during the heating season, or if the condition of the water in the gage glass indicates that the boiler water has considerable foreign material in it, the boiler should be drained and thoroughly flushed out. This can be done by removing the plugs in the front and rear sections and washing the boiler through these connections. Washing in this manner will normally remove any sludge or loose scale. However, if there is evidence that scale has baked hard to the internal surfaces, arrangements should

be made to have the boiler chemically cleaned by a reliable company that has had experience in this method of scale removal.

Leave Idle Boilers Filled

All idle cast iron boilers, whether for steam or hot water heating, will deteriorate less during idle periods if completely filled with water. Steam boilers should be filled at least to the top of the water gage glass or preferably up to the steam outlet connection. The boiler and system in hot water heating plants should be left entirely filled.

Leaving the boiler entirely filled with water will also prevent the possibility of damage by overheating should some person start a fire before the heating season, or early in the heating season without first checking the water level.

The only exception to the above statement that cast iron boilers should be left full of water when idle, applies to boilers of this type that are left idle during the winter months in a location where freezing is a possibility. Such boilers should be left drained and dry, preferably with the drain connections and other openings wide open so that the internal surfaces will dry out.

When boilers have been drained because of a possibility of freezing, a prominent or easily read sign should be

Service all operating and protective controls during the summer months.

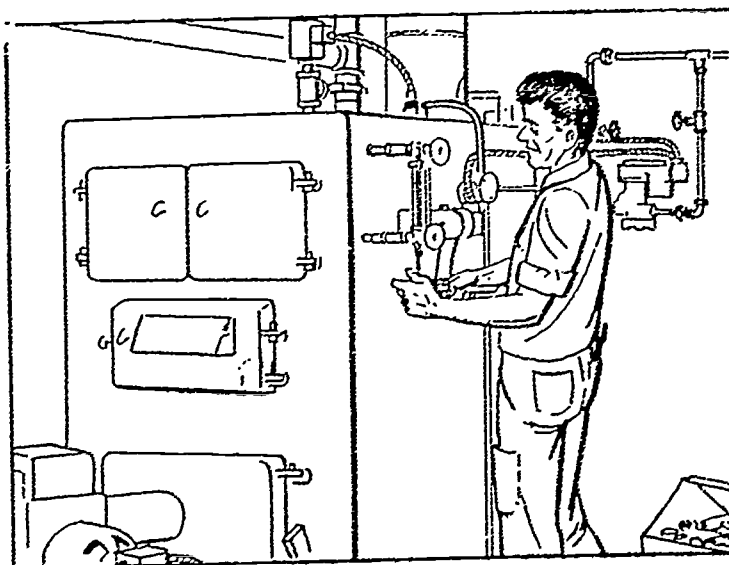

placed on them to warn that they are not to be fired until filled and properly prepared for service.

Other Maintenance Practices

An additional worthwhile maintenance procedure is to further inspect the boiler to determine that no cracks or leaks exist and that there are no air leaks in the breeching. Any cracked or warped cleanout doors that require sealing, repair or replacement, should be marked for attention. The boiler and breeching should be made as air tight as possible for greater operating economy when returned to service. Air leaks at boiler openings or in the breeching waste fuel.

When the boiler itself has been checked, then all piping, joints and fittings in the steam and water lines should be examined for leaks or serious corrosion. All leaks should be repaired and badly corroded parts renewed before the next heating season begins.

Return Piping

It is of utmost importance that all return piping in connection with either steam or hot water heating boilers be carefully examined at frequent intervals, and the inspection of this piping during the idle season should be most thorough. Leakage in return piping could put the boiler out of service at a most inopportune time, so this piping should be maintained in good condition.

The water level in the boiler should be watched during the early part of the idle season to see whether any water is being lost. If so, and if the boiler is known to be free from leaks, the return piping should be carefully examined to determine where the water is escaping. If any portion of the return piping is buried, it is probable that the leak is in that section. This buried section of piping should then be subjected to a hydrostatic pressure test or dug up and exposed for an examination. All deteriorated piping should be replaced, preferably redesigning the system so that the piping will thereafter be acces-

sible for inspection. If the piping must be below floor level it is preferable that it be placed in a trench with a protective cover that may be removed to permit examination.

In any case where piping is buried, whether leakage is in evidence or not, it is advisable to subject that piping periodically to a hydrostatic test to determine whether or not it is sound.

Service All Controls

During the idle period all operating controls, such as the water glass, safety or relief valves, low water fuel cut-out, emergency water feeder, pressure controls and firing controls, including any automatic-firing device, should be carefully gone over and put in good order.

The water gage glass is an important device on a steam-heating boiler. The gage glass connections should be checked during each idle period to determine that they are open and free so as to give a true indication of the water level.

Low water fuel cut-outs and emergency water feeders if used should be disassembled and carefully checked during the idle summer months so that their proper operation during the next heating season will be assured. Many manufacturers of such controls have an established service whereby this type of equipment may be returned to them for checking and cleaning. Depending upon the type of service rendered, the unit may be repaired and returned, or replaced with a rebuilt cut-out. In either case, a completely overhauled and checked cut-out will be available for installation before the next heating season.

If the boiler is so provided, the burner and all operating controls should be serviced during the idle period by a reliable organization to insure trouble-free operation when it is again used. Special attention should be given all parts of the electrical system.

Safety and Relief Valves

As it is common practice to try the safety or relief valves at regular inter-

vals while the boiler is in service, the operator should know whether or not the valves are in satisfactory operating condition. If there is any question regarding the action of the valves, they should be removed and overhauled or replaced.

There are now available on the open market, for use with hot water heating and supply boilers, relief valves of a type that have been tested and approved by the National Board of Boiler and Pressure Vessel Inspectors and stamped as complying with the current requirements of the ASME Heating Boiler Code. Such valves are rated in Btu discharge capacity of either water or steam and are much more reliable than the older type water relief valves with which many boilers are equipped. Serious consideration should be given to replacing any existing non-code water relief valves with the new-type valves for greater protection.

Avoid Use as Incinerators

There have been a number of cases where serious damage to cast iron boilers resulted when they were used for burning rubbish or used as incinerators during the idle months. Cast iron boilers should never be used as incinerators, as there is a good possibility of the cast iron sections cracking because burning waste material often results in flash-fires that cause sudden expansion of the cold metal surfaces.

Summary

In summary, the points that should be observed at the end of the heating season by the owner of a cast iron boiler are as follows:

1. Clean all boiler surfaces, firebox, ash pit, breeching and ducts to protect against excessive corrosion.
2. Keep the boiler room dry and reasonably clean, taking care that debris, ashes, etc., are not allowed to accumulate around the boiler or piping.
3. Examine the boiler for evidences of rust growth between sections and check the tie-rods on push-nipple

type boilers to determine that the nuts have been backed off several turns, or that the rods are provided with split nuts or compression washers.

4. Keep the boiler *full* of water during the idle season to prevent corrosion and protect against the possibility of some person's starting a fire in a dry boiler. The exception to this rule is that idle boilers in locations where they may be subject to freezing, should be left drained and dry.
5. Replace any cracked or seriously warped clean-out doors and check for air leaks at clean-out openings and at the breeching, for greater operating economy.
6. Examine all piping, joints and fittings for corrosion and leaks, paying particular attention to return piping.
7. *Service or have serviced all operating and protective controls during the idle season to assure their proper operation during the heating season. This includes the safety valves, the low water fuel cut-out and emergency water feeder, the pressure control, and the fuel burner and all operating controls used therewith.*
8. Do not use idle cast iron boilers as incinerators.
9. Contact your insurance inspector for his advice in the event repairs are necessary.

A cast iron boiler should not be used as an incinerator. It can be cracked by such abuse.

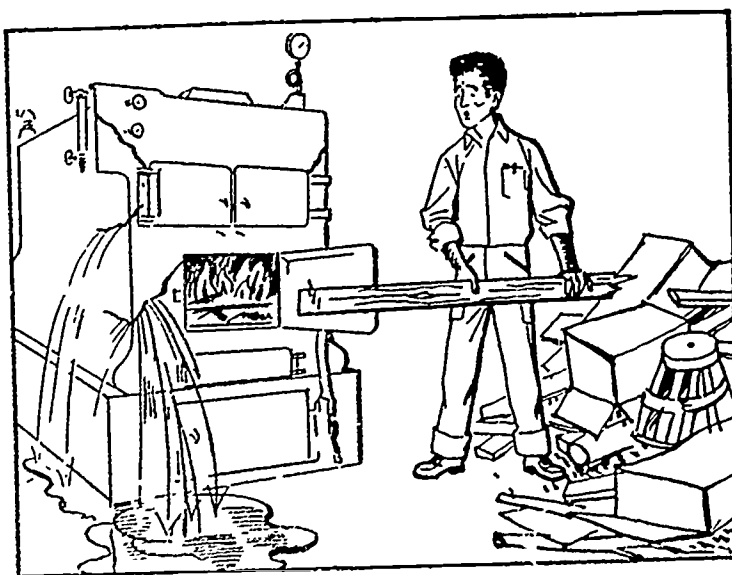

CHAPTER VIII

VENTILATION

CHAPTER VIII

VENTILATION

Ventilation is a process of supplying or removing air by natural or mechanical means to or from any space. This implies that ventilation is concerned with quantity of air, but for comfort and health we are concerned with securing air of the proper quality rather than supplying only a given quantity. Strictly speaking, we should use the term "air-conditioning" rather than "ventilation". Air-conditioning is the process by which the temperature, moisture content, movement and quality of the air in enclosed spaces are maintained within specified limits.

There are six factors that determine the degree of comfort experienced by the occupants of a school building. They are temperature, humidity, air motion, odor, dust and noise.

Contrary to old theories, the variations in oxygen and carbon dioxide content in the air are not too important; they are too small to be of physiological concern even under the worst conditions of normal human occupancy. However, we are interested in odor, dust, and humidity control, and so it is desirable to introduce a certain minimum amount of clean outdoor air. The amount of fresh air which should be introduced into a classroom has not been definitely determined but the location of the school building, condition of the outside air, and the number of persons in the room are a few of the factors which should be considered.

The regulations of the State Board of Education of Florida has established the following requirements:

Instructional areas must have at least thirty air changes per hour for summer ventilation and two air changes per hour

for winter ventilation. In places of assembly, there must be at least thirty air changes per hour for summer ventilation and three changes for winter ventilation. Other spaces such as gang toilet rooms, food laboratories, kitchens, and other spaces generating odors shall have at least four air changes per hour preferably by means of exhaust. Exhaust systems from sources of odor shall not be combined with other exhaust systems.

In addition, regulations require a minimum air space of 200 cubic feet per person in all occupied rooms.

METHODS OF VENTILATION

At least four methods of ventilation, when proper design and operation are provided, are desirable:

- (a) window ventilation
- (b) mechanical exhaust
- (c) mechanical supply
- (d) combination of the other three

There are several types of ventilating systems which might be classified under the heading of gravity systems. The gravity system depends for air movement on the fact that hot air is lighter in weight than cold air. This system is economical to install and brings fairly good results under certain conditions.

Window ventilation has the advantage of being the least expensive since there are no ducts, coils, dampers, motors, or fans. If a window is open, air currents will provide some air change. Window ventilation is used extensively in Florida and is coming into use again in colder climates even though it was once almost abandoned. It works well if properly designed and

used, particularly if windows are on two sides of the room at different levels. However, since teachers are busy people, they do not always get the most out of this ventilation system. In the rooms that have direct radiation heating systems, it is desirable to place window deflectors, which may be made of plate glass, in the windows over the radiators so that incoming air is deflected upward, thus preventing a draft on the students and at the same time providing for a proper mixture of the hot air from the radiator with cold air brought in from the outside. The practice of opening windows at the top and bottom may remove some of the heat from the room, but it is not considered an economical method of ventilation, since it removes the hot air from the top of the room directly to the outside instead of mixing it with the cool air near the bottom.

The mechanical exhaust system uses fans to pull air from the classroom to the outdoors. Air is pulled into the room from cracks in windows or through open windows. This is an excellent method to use for ventilating a toilet room, locker room laboratory or kitchen, since undesirable odors are pulled directly to the outside air. There can be little question that the mechanical system is the most efficient when properly installed and used.

There are several methods of installing duct systems. One is to provide ventilation ducts from each room out through the roof. No duct should serve more than one room. These ducts should be made fire-resistant to prevent fire from spreading from one part of the building to another through them. They should be in fire-resistant partitions and may be collected in the attic into what is known as a plenum chamber where several ducts come together and discharge through the roof in one vent. This system

is rather effective but is somewhat more costly to install than certain other systems.

A second system is what is known as corridor ventilation. Under this plan the foul air is taken out of the classroom under the cloakroom doors or through louvers and grills in the bottom of the classroom door and into the corridor. The air then moves up through the building and is taken out through ventilation ducts extending from the upper ceiling through the roof. This system is cheaper to install and has proven satisfactory in some buildings.

The mechanical supply system tempers the air supply of a room. Stale air is pushed from the room by incoming fresh air. Varying degrees of re-circulation may take place, ranging from 0 to 100%, depending upon temperature and air needs. Air is supplied through ducts either from one central fan or from individual room fans. Air is supplied mechanically by unit, forced warm air, or split system.

The unit ventilator combines heating and ventilating in the form of a room radiator, which contains a motor driven fan, automatic controls, and automatic dampers to regulate the amount of outside air to be admitted and the amount to be re-circulated. They are generally placed under the window to form a warm air shield between pupils and cold air coming off the window. Their distinct advantage is that heat and ventilation may be controlled in each room. Incoming air is filtered, but the filters must be cleaned regularly, especially in first floor classrooms, for dust and dirt may be pulled in by the fans.

Even though these systems are automatic in operation, the custodians must start and stop the unit ventilators with the rest of the heating system, must maintain a continuous supply of steam or hot water, and must service

the units regularly to insure their continuous trouble-free operation.

Forced warm-air systems are used only in small school buildings, in which air may be forced around the room from the heating unit. A thermostat controls the flow of air which is forced into the room around its perimeter. Stale air is exhausted from the room from registers high in the wall.

The split system is a combination of forced warm air and direct radiation. The air is warmed by thermostatically controlled steam or hot water coils and is forced into the room by fans. Air is pulled from the room by a central fan and re-circulated. Additional heat is supplied, if needed, by direct radiators in the room. The controls are elaborate and complicated, so the custodian must be well trained to get the best results from the least operating difficulty.

AIR CLEANING

Air cleaning devices remove contaminants from an air or gas stream. They are available in a wide range of designs to meet various air cleaning requirements. Atmospheric dust is a complex mixture of matter made up of smokes, dusts, mists, and fumes which are generally referred to as aerosols. A sample of atmospheric dust gathered at any given point will generally contain minute particles of materials that are common to that locality, together with other components which may have had their origin at quite some distance, but which have been dispersed by wind or air currents. A sample of atmospheric dust will usually contain minute quantities of soot and smoke; silica; clay; decayed animal and vegetable matter; organic materials in the form of lint and plant fibers; and metallic fragments. It may also contain mold spores, bacteria, plant pollen and similar particles which may motivate an allergy attack on sensitive people.

Air cleaning devices are divided into two basic groups: air filters and industrial air and gas cleaners. Air filters are ordinarily used to remove contamination such as is found in outdoor air and are employed in ventilation, air-conditioning, and heating systems. School custodians will, in most cases, be only concerned with air filters.

Air filters can generally be classified into three groups, depending upon their principle of operation as (1) viscous-impingement, or wet type, (2) dry, and (3) electronic.

Viscous-impingement filters employ a viscous coated media such as oil, or other adhesive, against which the dust particles strike and are then held by the viscous surface.

Dry or semi-dry types are sometimes referred to as strainer or screening types of filters. The media generally consists of extremely small elements or fibers spaced closely together, so that the air stream must seek a torturous and meandering path in its passage through the filter.

Electronic air filters utilize an electrostatic field.

Each type of air filter has certain advantages and limitations, but the variety of designs which are available today provides an opportunity to choose the filter having the characteristics best suited for a given application. Sometimes it is desirable to use two or more filters in series, especially if an abnormal concentration of dust is anticipated and if a high degree of dust removable is desired. The wet or adhesive types of filters are best suited for the removal of the larger size dust particles and for handling high dust concentrations. A wide range of dry types of filtering media are available and these are quite effective on the smaller particles of atmospheric dust but generally must be serviced at frequent intervals. They are particularly suitable for the collection of lint.

Unit filters generally have metal frames which are riveted or bolted

together to form a filter bank or section. The rate of loading of the filter obviously depends upon the type and concentration of the dirt in the air being handled and upon the operating cycle of the system. For this reason, periods between maintenance cannot be predicted with certainty. Manometer or draft gauges are often installed to measure the pressure drop across the filter bank and thereby indicate when the filter requires servicing. The manner of servicing filter units depends upon their construction. Disposable types of filters are constructed of inexpensive materials and are designed to be discarded after one period of use. The cell sides of this design are usually a combination of cardboard and metal stiffeners. The permanent type of unit filters are generally constructed of metal in order to withstand repeated handlings. Various cleaning methods have been recommended for filters of this design, but the most widely used procedure involves washing the filter with steam or water to which has been added a detergent and then dipping or spraying the filter with its recommended adhesive or oil. The excessive adhesive or oil should be allowed to drain from the filter before it is put back into service. In order to provide as uniform an operating resistance as possible, it is sometimes advisable to use the rotation system of filter maintenance, where large banks are involved. In this procedure a portion of the filter bank is reconditioned on an established schedule.

The media used in dry types of air filters are usually fabric-like or blanket-like materials of varying thickness. Media of cellulose fibers, bonded glass, wool felt, asbestos, synthetics, and other materials have been used commercially. The medium in filters of this type is frequently supported by a wire frame in the form of pockets or v-shaped pleats and in other designs the media may be self supporting. The efficiency of dry type air filters is usually higher than that of the viscous adhesive type filters,

however, the life or dust holding capacity is usually lower because the dust tends to clog the fine pores or openings thereby causing a higher rate of resistance rise.

In some designs of dry type air filters, the filter media is replaceable and is held in position in permanent metal cell sides. In other designs the entire cell is disposed of after it has accumulated its dirt load.

In school air handling systems which include air filters the responsibility for checking, cleaning, or changing air filters generally falls upon the school custodian. A thorough study of the operating instructions supplied by the manufacturer plus periodic inspections is necessary to establish the frequency of servicing the filters. Failure to do so, and allowing the filters to become overloaded with dust and dirt can reduce the air flow and efficiency of the system drastically.

CHAPTER IX
AIR-CONDITIONING

CHAPTER IX

AIR-CONDITIONING

Man's comfort and progress have been greatly influenced by climatic conditions. Artificial control of humidity, temperature, air motion, and air cleanliness is termed air-conditioning. As we know, air-conditioning is accomplished in part through ventilation. Air-conditioning combines ventilation with air cleaning, heating, cooling, humidifying, and effective control of air in motion within an enclosure. Most people associate air-conditioning with summer air cooling, but this is not completely accurate. Air-conditioning is not seasonal.

This new feature of ventilating is already being used in schools, especially in the warmer areas of the United States. Most new schools being built in Florida today are being planned for 100% air-conditioning. The term used in place of air-conditioning in some school is "climate control". Air-conditioning is used to combat these conditions:

1. Temperatures that rise into the high 90's during the school term.
2. Dust, which requires natural ventilation to be curtailed, and demand an air washing system.
3. Outside noises which must be eliminated or controlled, such as those from air fields or highways.
4. Discomfort due to summer heat in buildings used for summer training programs, summer school programs, or enrichment programs.
5. Heat and humidity which must be controlled in rooms used for scientific and athletic purposes.
6. Stale air which cannot be adequately replaced by natural ventilation.

A group of complex factors affect the air-conditioning load. They are: (1) heat transmission, (2) solar radiation or sun effect, (3) people, (4) light and power equipment, (5) ventilation air or infiltration, (6) product load, and (7) miscellaneous.

Heat transmission is the heat flow through walls, floors, windows, ceilings, and roof. It comes about from a temperature difference between the inside air-conditioned space and the outside atmosphere. Heat flows in if the temperature is higher outside. This unwanted heat must be removed by cool air.

Weather conditions make up most of the heat transmission load in conditioned spaces. Local weather bureaus forecast valuable information on this subject. An operation engineer can use forecasts to plan operations ahead. Insulating spaces or buildings against transmission loads reduces the load on the air-conditioning equipment.

Large places, such as classrooms and auditoriums, filling with people suddenly can add to the heat load sharply. The area to be cooled should be brought to the proper temperature before people arrive. It is much easier to hold conditions after a precooling period than it is to bring down conditions by starting up a cooling system after people arrive.

Lights add very little heat to average spaces, but extensive lighting and the use of oversized bulbs often make up a large portion of the load. The lighting load can be estimated by multiplying the total watts by 3.4.

Infiltration or ventilation represents an important load factor. It varies with weather conditions, people load, and building construction. Tightness of doors, windows, etc., are important preventive measures. The mechanical elements of an air-conditioning system are:

(1) a means of cleaning the air, either by direct contact with water spray, by air filters, or by electrostatic precipitation;

- (2) an air-conditioning chamber in which the air is cooled and humidified or dehumidified either by direct contact with a water spray or by surface cooling with an additional means for humidification;
- (3) a means of eliminating all free water;
- (4) a fan, usually of the centrifugal type, for moving the air;
- (5) a re-heater, for adding heat when required for purposes of controls;
- (6) a system for air distribution which is free of local drafts.

Air-conditioning systems are either unit or central systems.

UNIT AIR-CONDITIONERS

A room air-conditioner is a factory-made encased assembly designed as a unit for mounting in a window, through the wall, or as a console. It is designed for free delivery of conditioned air to an enclosed space without ducts.

These air-conditioners are designed to control ventilation, air circulation, air cleaning, and heat transfer, along with cooling and maintaining temperature and humidity, in a single room. Such self-contained air-conditioning or cooling units are generally below 15 tons capacity. Unit air conditioners are widely used for administrative offices in the public schools. They are usually restricted to hot-weather operation and range from 1/4 to 1 1/2 tons refrigeration capacity. These are usually designed to be installed in the lower part of a window, although floor models installed in front of a window are also used. Most window air-conditioners take the condensed moisture from the cooling coil and spray it over the condenser surface and vaporize it, thus eliminating the need for drain connections. It is possible to remove the equipment for winter storage, or to use it for winter ventilation. Each of these units must be cared for individually.

Most units have adjustable louvers or deflectors to distribute the air into the room with satisfactory "throw" and without drafts. When the unit has only one deflector, all air is delivered in one direction; when it has several deflectors, the air can be discharged in several directions simultaneously. Discharge air velocities range from 300 to 1200 fpm with low velocities preferred in rooms where people are at rest.

Many schools are now utilizing equipment known as "Unit Ventilators".

UNIT HEATING SYSTEM

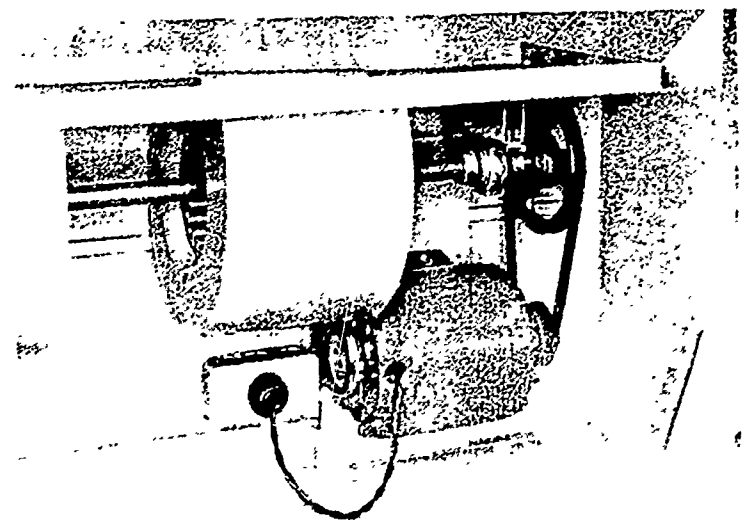
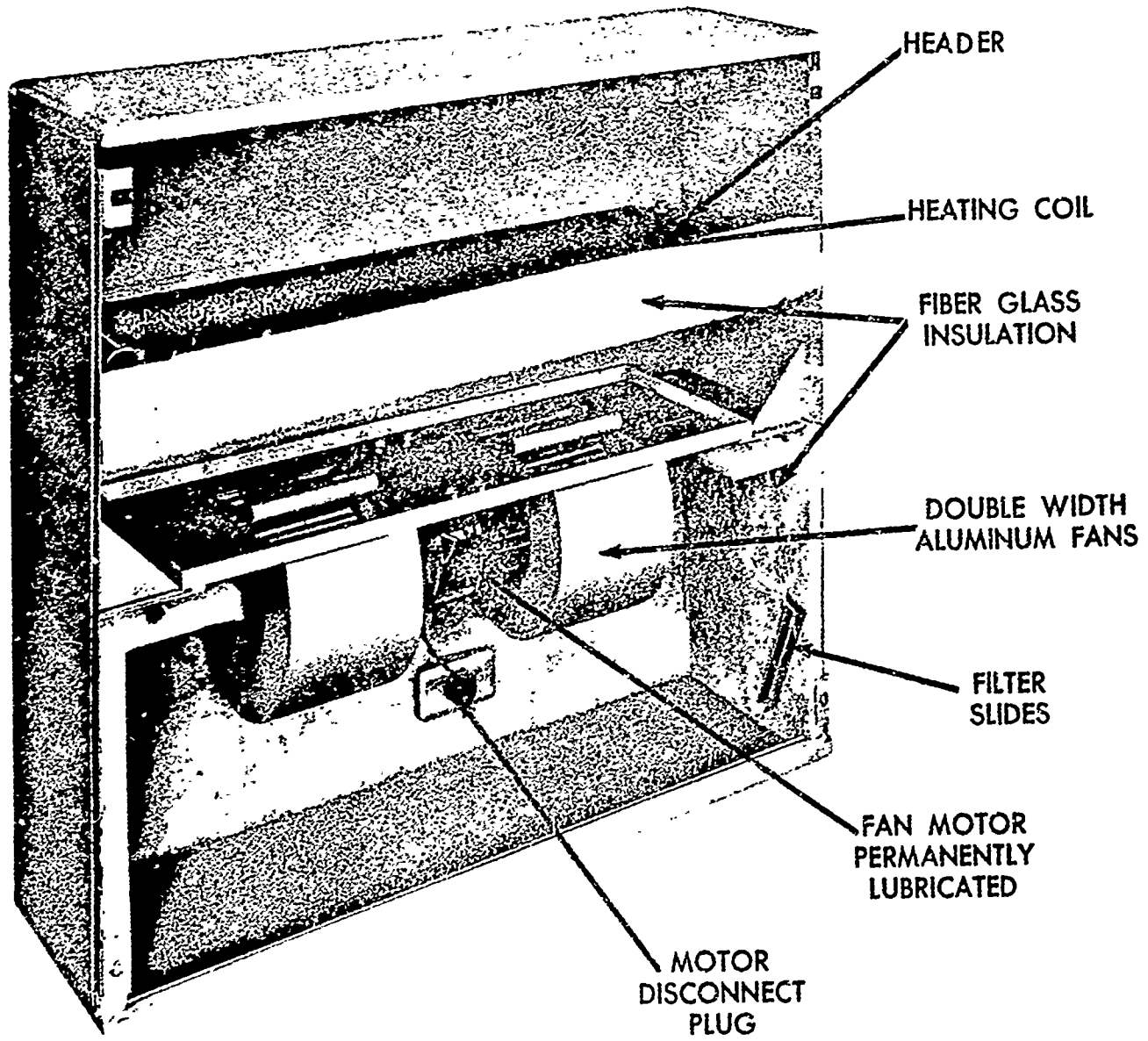

FIGURE 8

for cooling and heating individual rooms. Unit ventilators are not a complete, self-contained, air-conditioned assembly. While they incorporate almost all of the features normally found in room air-conditioners, such as air mixing, ventilation, automatic controls, etc., they receive their cooling and heating medium from a central source through insulated plumbing. Thus, the unit ventilator is a combination of both types, the "unit" and the "unitary".

CENTRAL AIR-CONDITIONING

Central air-conditioning systems use "unitary" equipment such as fans, coils, filters, etc., which are designed for assembly in the building, rather than at the factory. A central system usually serves several rooms, with individual controls for each room. Where early models were generally represented by a one-piece, floor mounted, water-cooled unit, today the equipment group includes floor, ceiling, and wall mounted models both of one piece unitary design and of two or more sections remotely installed with inter-connecting refrigerant piping.

The term "unitary air-conditioner" now includes an extremely broad range of equipment and, therefore, presents a difficult problem in definition and classification. The industry, through its group representative, the Air-Conditioning and Refrigeration Institute, has recently agreed upon the following definition of a unitary air-conditioner:

"A unitary air-conditioner consists of one or more factory-made components, assembled on the site and normally include an evaporator or cooling coil, a compressor and condenser combination, and may include a heating function as well. Where such equipment is provided in more than one assembly, the separated assemblies are to be designed to be used together."

Such a system generally is cheaper than several individual units and may be placed in an out-of-the-way place, such as the basement or attic. Ducts are generally used with a centralized air-conditioning system. Exhaust fans pull the desired amount of air from the rooms, and return air fans replace it with "new" or cleaned air. Generally outdoor air is pulled

in and distributed to the rooms in specified amounts. The returned air may be either heated or cooled.

Capacities of units presently range from 2 to 75 tons with the top limit subject to upward pressure in recent years. The industry has not standardized on capacity steps within this range, and therefore, no series of standardized sizes is available. In the range of 2 to 7 1/2 tons, the industry presently builds equipment having capacity ratings at almost every step above the 1000 BTUH increment. From 7 1/2 to 50 tons, the steps are generally in the range of 2 1/2 to 5 ton increments.

No particular pattern has been established in the industry for either the shape or arrangement of components for unitary air-conditioning equipment. Thus, the designer has a relatively free choice within the scope of equipment classification with regard to shape, size, and general arrangement.

CENTRAL SYSTEM DESIGN COMPONENTS

The design of a complete air-conditioning system to produce a given capacity at a stated operating condition can usually be accomplished by a wide variety of component combinations. The following paragraphs are intended to serve as a general description of the various components used in unitary air-conditioning systems.

REFRIGERATION SYSTEM

The refrigeration system in a unitary air-conditioner includes the following:

1. Compressor. Compressors are usually of the reciprocating or centrifugal type. The rotary cam type does not have the capacity needed in large systems and its use is usually limited to window units and other

refrigeration uses.

2. Cooling Coil. Cooling Coils are either direct-expansion type evaporators or chilled-water coils for use with a water chiller.

3. Condenser. Condensers are of three types: water-cooled, air-cooled, and evaporative-cooled.

Water-cooled condensers, although least expensive from a first-cost standpoint, have lost favor due to water shortages and the fact that they can freeze up in winter time.

Air-cooled condensers require no water, can operate at all seasons of the year, and have no water-treatment problems.

Overall cost for evaporative-cooled condensers are comparable to air-cooled condensers.

4. Expansion device. Current design uses capillary tubes, constant pressure valves, and thermostatic expansion valves (adjustable or non-adjustable super-heat). No specific expansion device is particularly favored, each being used as the design situation warrants.

5. Refrigerants. Unitary equipment is currently designed for use of Refrigerants 12, 22, and 500.

6. Water Chillers. Unitary air-conditioners designed for use with a remote chilled-water cooling coil must include a water chiller.

7. Refrigerant piping. Piping can be factory-assembled or in the nature of piping with quick-connect couplings. The quick-coupling connections eliminate the need for field-fabricated joints, purging, and leak-testing.

AIR-HANDLING SYSTEM

The air-handling system includes the following:

1. Propeller Fans. Usually used in the cooling of condensers.

2. Housed Fans. Evaporator air systems, in general, and some condenser air systems, are designed for use with extensive duct work. Therefore, evaporator air fans are almost always of the housed type.

3. Fan Motors. Fan motors must be quiet and dependable. Since servicing can be difficult due to location after installation, motors frequently must be life-time lubricated.

4. Direct vs. Belt Drive. Propeller fans which rotate up to speeds of 1500 rpm and below 30 inches in diameter are usually direct-drive. Larger fans and housed fans are usually belt driven. Housed fans of the larger sizes are almost exclusively belt-driven.

5. Filters. Both disposable and cleanable type filters are in use. The filter is always located on the inlet side of the evaporator coil to prevent dirt accumulation on the wetted coil surface.

CONTROLS SYSTEM

The controls system includes safety devices, protective controls and capacity control devices.

1. Safety devices. Since the unitary air-conditioner is a pressure system, protection from excessive pressures must be provided. A high pressure cutoff is always required to shut off the compressor if the head pressure should rise above normal working limits. Protection from excessive pressure due to fire is required in the form of a fusible plug or similar device.

2. Protective Controls. The control system normally contains at least some of the following protective devices to prevent damage to system components due to abnormal operation:

- a. Compressor Motor: Electrical operation overload protection.
- b. Compressor Motor: Electrical locked-rotor protection.

- c. **Low-Pressure Cutout:** Prevent freeze-up, operation on low charge, and excessive oil foaming.
- d. **Fan Motor Overload:** Electrical overload protection.
- e. **Wiring:** Short circuit protection.

3. Capacity Controls. On larger units capacity control is provided to match fluctuating load conditions. This is accomplished by one of several means, including multiple circuit systems, compressor unloaders, and suction-pressure regulators. Head pressure control is also used in this sense.

HEATING SYSTEM

Heating is accomplished by steam or hot water coils when the unit is used in conjunction with an auxiliary heating unit. A recent trend has been toward unitary design, including a direct-fired heater as an integral component. These heaters may be either gas or oil-fired, and resemble duct heaters in basic design.

CHAPTER X
CONTROLS FOR HEATING, VENTILATING, AND AIR-CONDITIONING SYSTEMS

136 / 137

CONTROLS FOR HEATING, VENTILATING, AND AIR-CONDITIONING SYSTEMS

Present day standards of comfort combined with capacity and rapid response of modern heating and cooling equipment make automatic controls an essential part of heating, ventilating, and air-conditioning systems. These automatic controls respond to variables such as temperature, relative humidity, and pressure. They operate individually or in sequence to maintain the desired conditions throughout the system and in the occupied space. A factor that has made the subject of automatic control somewhat confusing has been the matter of terminology. Many different expressions or words have sometimes been used to convey a single idea or concept. This section, therefore, attempts to use and define the terms that are most common and suitable so that they may be readily understood.

FUNDAMENTALS OF AUTOMATIC CONTROL

A control system consists essentially of (1) a controller, (2) a controlled device, and (3) a source of energy.

A controller is a device which measures a variable condition such as temperature, humidity, pressure, and liquid level, and produces a suitable action or impulse for transmission to the controlled devices. Thermostats, humidistats, and pressure controllers are examples.

A controlled device reacts to the impulse received from a controller and varies the flow of the control agent. It may be a valve, damper, electric relay, or a motor driving a pump, fan, etc.

The control agent is the medium manipulated by the controlled device. It may be air or gas flowing through a damper; gas, steam, water, etc., flowing through a valve; or an electric current.

The controlled variable is the condition such as temperature, humi-

dity, or pressure, being controlled.

Most control systems form a closed loop. That is, the controller measures and responds to a change in the controlled variable and actuates the controlled device to bring about an opposite change which is again measured by the controller. This system of transmitting information back to its origin is known as feedback, and makes true automatic control possible.

An open-loop system is sometimes employed in control circuits, but does not provide complete control. An outdoor thermostat arranged to control the flow of heat to a building in proportion to the load caused by changes in outdoor temperature is an example. This system has no feedback. It depends for its operation on a pre-arranged relationship between outdoor temperature and heat input to the building, and room temperature has no effect upon the controller.

Control systems are divided into five main groups according to the primary source of energy:

1. A self-contained system combines the controller and controlled device in one unit and employs the power of the measuring system to effect the necessary corrective action. The measuring system derives its energy from the process under control without amplification from any auxiliary source of energy, and may be of the "sealed-bellows" or "remote-bulb" type. Temperature changes at the bellows or the remote bulb result in pressure or volume changes of the enclosed media which are transmitted directly to the operating device of the valve or damper.

2. A pneumatic system utilizes compressed air, usually at a pressure of 15 to 25 psig, as a source of energy. This is supplied to the controller, which in turn, regulates the pressure supplied to the controlled device.

3. A hydraulic system utilizes a suitable liquid under pressure as the source of energy. The pressure often is considerably higher than a

pneumatic system, but in other respects the systems are similar. Hydraulic systems find their chief use in applications where large forces are required for operation of the controlled devices.

4. An electric system utilizes electric energy, either low or line voltage as the energy source. The electric energy supplied to the controlled device is regulated by the controller either directly or through relays.

5. An electronic system also uses electric energy, but employs an electronic amplifier to increase the minute voltage variations of the measuring element to values required for operation of standard electrically controlled devices. Measuring elements are usually of the resistance type, but thermocouples also are employed.

In addition to the conventional controllers and controlled devices, many control systems require auxiliary devices to perform various functions.

Auxiliary controls for electric control systems includes:

1. Transformers to provide current at the required voltage.
2. Electric relays for intermediate control, time-delay, etc.
3. Potentiometers for manual settings or remote adjustments.
4. Manual switches for a variety of jobs.
5. Auxiliary switches on valves and dampers for sequencing.

Auxiliary control equipment for pneumatic control systems include:

1. Air compressors and accessories, for energy.
2. Electropneumatic relays for controlling certain functions.
3. Pneumatic-electric relays for making or breaking electric contact by air pressure.
4. Many types of pneumatic relays.

5. Positioning and switching relays.

6. Pneumatic and gradual switches.

Auxiliary control devices common to both electric and pneumatic systems include:

1. Sequence controllers for operating a number of devices in a pre-determined sequence for safe and efficient operation.
2. Clocks or timers for turning apparatus on and off at pre-determined times, for switching from day to night operation, and for other time-sequence functions.

CONTROL AREAS

Areas to be controlled may be classified as (1) central, (2) zone, and (3) individual room.

Central control uses only one controller for the entire affected area which makes no provisions for variations in exposure of different parts of the buildings or different occupancy load conditions.

Zone control for any heating, ventilation, or air-conditioning system is employed where it is desired to control, by one set of controls, the heating or cooling effect in a number of rooms or areas, having similar orientation or occupancy. For zone control to be successful, the requirements must be approximately consistent throughout the extent of the zone. Zone controls alone may not provide satisfactory temperature conditions in all rooms or areas within the zone because occupancy, lighting load, space arrangements, and similar factors cannot always be predicted with accuracy. A combination of zone controls with individual room control in critical areas may be necessary to achieve complete satisfaction.

Individual room control. The ideal temperature control system for any building is one that promotes maintenance of the desired temperature in

every room at all times regardless of the location and occupancy. Individual room control is desirable in schools, hospitals, and offices.

The advantage of individual room control is in fuel economy and comfort for the occupants.

CHAPTER XI

HEAT PUMPS

144 / 145

CHAPTER XI

HEAT PUMPS

The term HEAT PUMP as applied to year-round air-conditioning system, commonly denotes a system in which refrigeration equipment is used in such a manner that heat is taken from a heat source and given up to the conditioned space when heating service is wanted, and is removed from the space and discharged to a heat sink when cooling and dehumidification are desired. The thermal cycle is identical with that of ordinary refrigeration, but the application is concerned alike with the cooling effect produced at the evaporator and with the heating effect produced at the condenser. In some applications, both the heating and the cooling effects obtained in the cycle are employed simultaneously.

The heat-pump principle is also applied for purposes other than air-conditioning, such as: supply of domestic hot water in residences and commercial buildings, recovery of low-temperature heat as a useful by-product in industrial operations, and disposal of heat from processes involving evaporation of water or other fluids at depressed temperature and pressure. Defrosting of evaporator coils in refrigerating systems by intermittently admitting hot gas directly from the compressor is another application of the heat-pump method.

Even though the heat-pump principle is not new, extensive use of this principle in practical devices has been accomplished only within the past twenty years. Large central heat-pumps of modern design, within the capacity range of about 100 to approximately 1,000 horsepower of compressor-motor rating, are now operating in a substantial number of buildings.

Compressor types employed in large central systems vary from one large centrifugal unit to as many as eight multi-cylinder reciprocating units. A single or central system is generally used throughout the building, but in some

HEAT PUMP SYSTEM

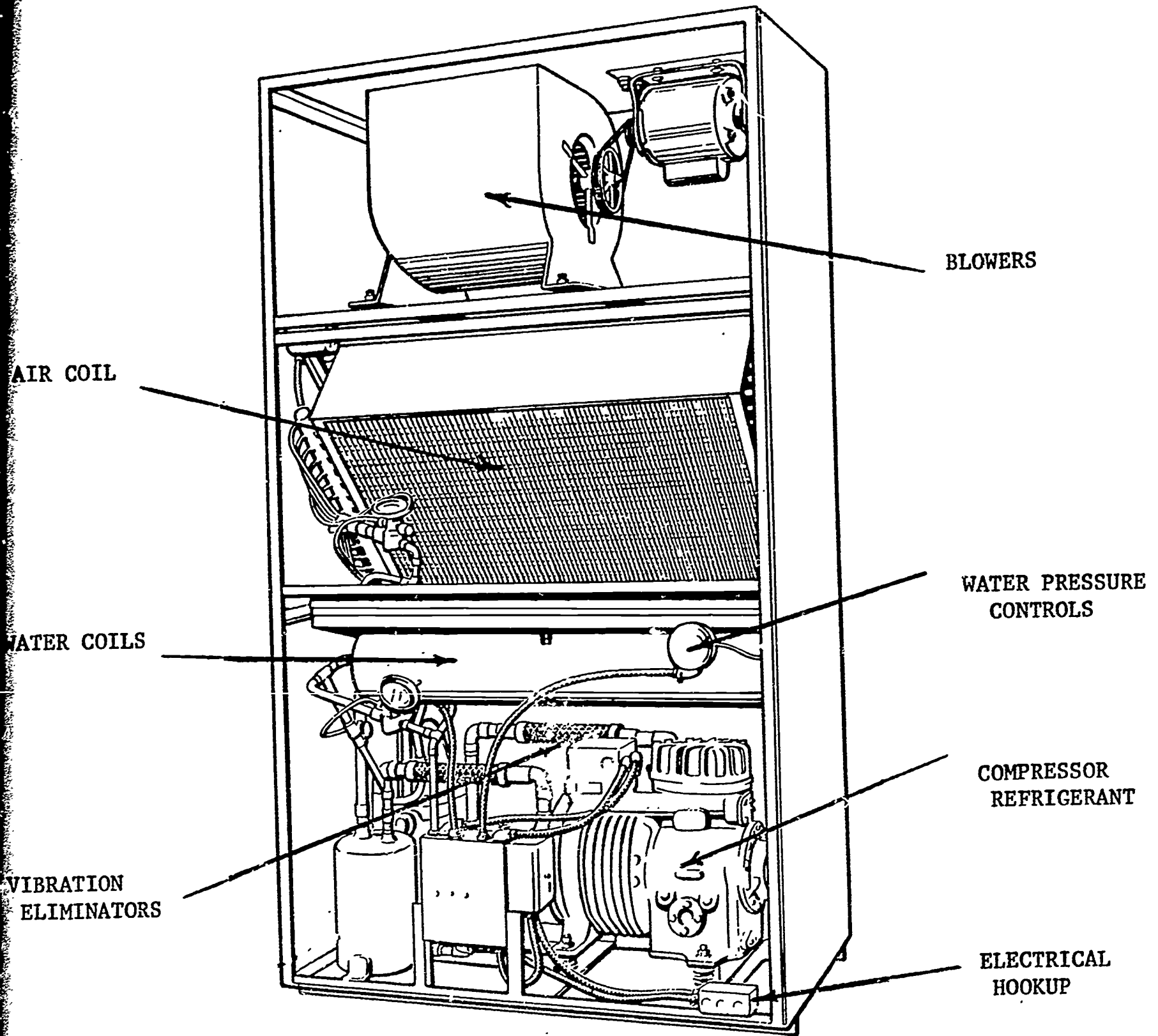

FIGURE 9

instances the total capacity is divided among several separate heat pump systems to facilitate zoning. Both well water and air are used as heat sources. Compression is accomplished in two stages for a few recent projects. Frequently, provision is made for heating and cooling to be supplied simultaneously to separate zones of the building.

BASIC CIRCUITS

Fundamentals

Since, from the refrigeration standpoint, a heat pump is similar to a conventional refrigeration system, its basic circuit may be represented by Figure 1. Changeover between heating and cooling services may be accomplished by: (a) actuating valves in the refrigerant lines, so as to interchange the positions of heat exchangers constituting the evaporator and condenser, respectively, in the refrigerant flow circuitry, or (b) by switching the paths of air, water or other fluid that convey heat from source to evaporator and from condenser to sink, respectively. The interchange function inherent in heat-pump control led to use of the term reversed-cycle refrigeration during the early development period of the heat pump, but this inaccurate name is now obsolete.

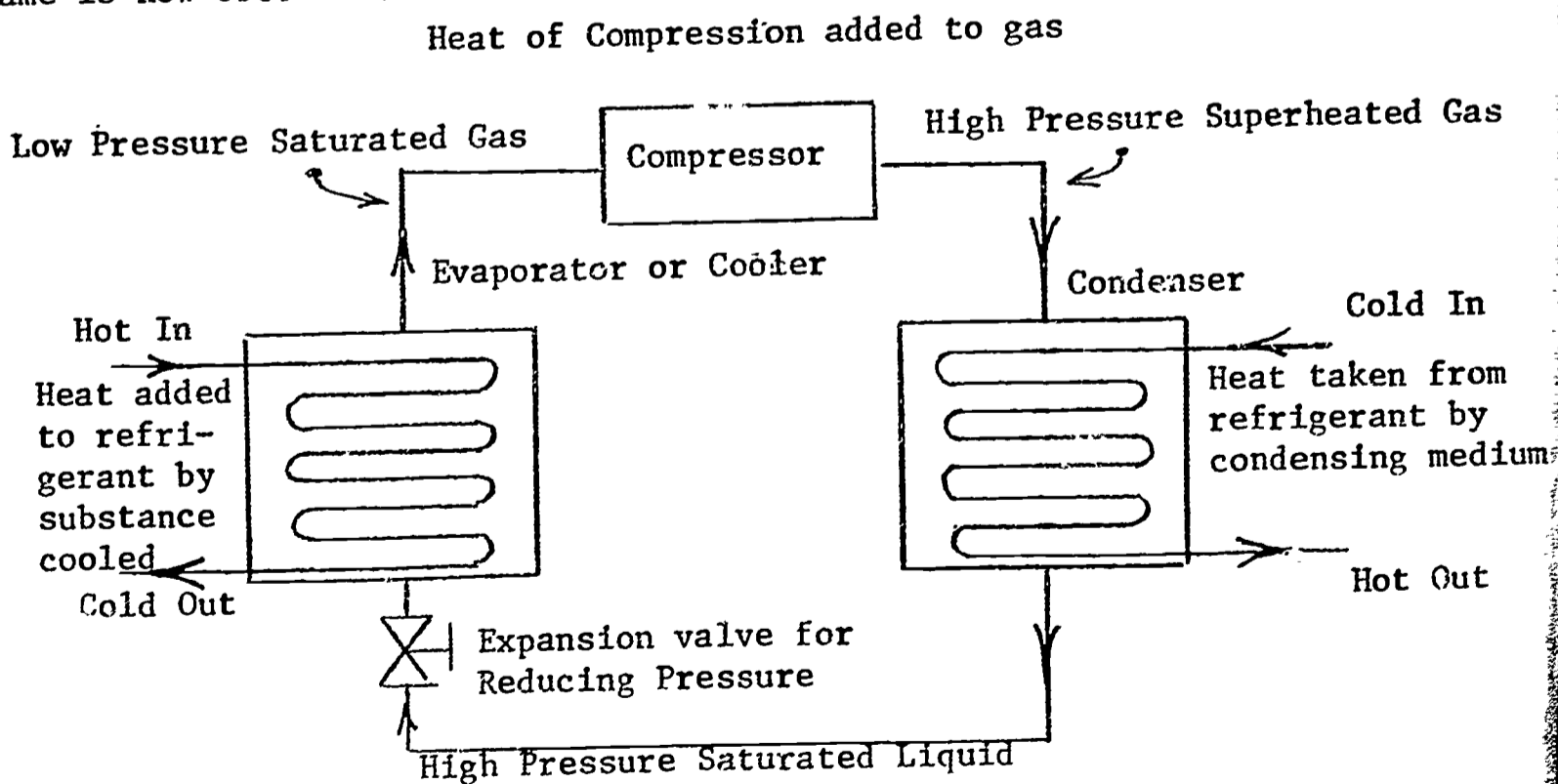

HEAT PUMP TYPES

Heat pumps for air-conditioning service may be classified according to:

- (a) type of heat source and sink,
- (b) heating and cooling distribution fluid,
- (c) type of thermodynamic cycle,
- (d) Type of building structure, and
- (e) size and configuration.

The more common types are shown in Table 1.

The air-to-air type is the most common type of system. It is particularly suitable for factory-built unitary heat pumps and has received favorable acceptance for residential and commercial applications. The first diagram in Table 1 is typical of the refrigeration circuit employed. A few installations have been made where the forced-convection indoor heat-transfer surface has been replaced with a radiant panel.

In air-to-air heat pump systems, as shown in second diagram of Table 1, the air circuits may be interchanged by means of dampers (motor driven or operated manually) to obtain either heated or cooled air for the conditioned space. With this system one heat-exchanger coil is always the evaporator while the other is always the condenser. The conditioned air will pass over the evaporator coil during the cooling cycle while the outdoor air will pass over the condenser. The change from cooling to heating is accomplished by positioning the dampers.

A water-to-air heat pump uses water as a heat source and sink and uses air to transmit heat to or from the conditioned space.

Air-to-water heat pumps are commonly used in large buildings where zone control is necessary, and are also sometimes employed for the production of hot or cold water in industrial applications.

Common Heat Pump Types

HEAT SOURCE AND SINK	DISTR. FLUID	THERMAL CYCLE	DIAGRAM ▨ HEATING ⇨ COOLING ⇨ HEATING AND COOLING
AIR	AIR	REFRIGERANT CHANGEOVER	
AIR	AIR	AIR CHANGEOVER	
WATER	AIR	REFRIGERANT CHANGEOVER	
AIR	WATER	REFRIGERANT CHANGEOVER	
EARTH	AIR	REFRIGERANT CHANGEOVER	
WATER	WATER	WATER CHANGEOVER	

● ALL SINGLE STAGE COMPRESSION

ASHRAE Guide & Data Book 1961

TABLE 1

Earth-to-air heat pumps may employ direct expansion of the refrigerant in an embedded coil as illustrated in Table 1, or they may be of the indirect type described under the water-to-air type.

A water-to-water heat pump uses water as the heat source and sink for both heating and cooling operations. Heating-cooling changeover may be accomplished in the refrigerant circuit, but in many cases, it is more convenient to perform the switching in the water circuits such as is illustrated in Table 1.

In earth-to-water heat pump (not shown in Table 1) may be like the earth-to-air type shown except for the substitution of a refrigerant-water heat exchanger for the finned coil shown on the indoor side. It may also take a form similar to the water-to-water system shown when a secondary-fluid ground coil is used.

Some heat pumps which use the earth as the heat source and sink are essentially of the water-to-air type. An antifreeze solution is pumped through a loop comprised of a pipe coil embedded in the earth and the chiller-condenser.

Other types of heat pumps in addition to those listed in Table 1 are possible. An example is one which utilizes solar energy as a source of heat; its refrigerant circuit may resemble the water-to-air, air-to-air, or other types depending upon the form of solar collector and the means of heating and cooling distribution which is employed.

Another variation is the use of more than one heat source. Some heat pumps have utilized air as the primary heat source, but are changed over to extract heat from water (e.g. from a well or storage tank) during periods of peak load. The use of solar energy requires another heat source during periods of insufficient solar radiation.