

ED 025 098

School Plant Maintenance and Custodial Services
Kentucky State Dept. of Education, Frankfort.
Pub Date 67

Note- 170p.

EDRS Price MF-\$0.75 HC-\$8.60

Descriptors- Carpeting *Cleaning *Custodian Training *Equipment Maintenance, Flooring, Furniture, Guidelines,
*Instructional Materials, Maintenance, Manuals, Public Health, Repair, Safety, *School Maintenance

School maintenance guidelines are directed to the local school situation where the custodian may have neither the opportunity for any formal training or experienced personnel available to instruct him. Topics covered are those that are thought to be of greatest value to the local school custodian and include--(1) floor care, (2) carpet cleaning, (3) classroom cleaning, (4) cleaning corridors and stairs, (5) cafeteria cleaning, (6) cleaning the auditorium, (7) window cleaning, (8) ceiling cleaning, (9) wall cleaning, (10) cleaning lighting fixtures, (11) cleaning window shades, (12) cleaning furniture, (13) chalkboards, (14) tackboards, (15) cleaning exterior of building, (16) summer cleaning program, (17) storage, (18) water supply systems, (19) heating and ventilating equipment, and a (20) bibliography. (RH)

U.S. DEPARTMENT OF HEALTH, EDUCATION & WELFARE
OFFICE OF EDUCATION

THIS DOCUMENT HAS BEEN REPRODUCED EXACTLY AS RECEIVED FROM THE
PERSON OR ORGANIZATION ORIGINATING IT. POINTS OF VIEW OR OPINIONS
STATED DO NOT NECESSARILY REPRESENT OFFICIAL OFFICE OF EDUCATION
POSITION OR POLICY.

School Plant Maintenance And Custodial Services

ED025098

EF 001816

1967



COMMONWEALTH OF KENTUCKY
DEPARTMENT OF EDUCATION
FRANKFORT, KY. 40601

HARRY M. SPARKS
SUPERINTENDENT OF PUBLIC INSTRUCTION

January 1967

The Department of Education is aware of the importance of proper maintenance in our schools and the need for assistance in training custodial help. This manual has been written not only to acquaint new personnel with proper procedures but also to suggest time and labor saving devices to the experienced custodian.

We hope that this publication not only proves to be a useful tool to the custodians but will also aid those school administrators who work with custodians and are responsible for school plant operations to more effectively meet the needs of their districts.

A handwritten signature in cursive script that reads "Harry M. Sparks".

Harry M. Sparks
Superintendent of Public Instruction

ED025098

TABLE OF CONTENTS

	Page
THE PURPOSE OF THIS MANUAL	iv
CHARACTERISTICS OF A GOOD CUSTODIAN	1
GENERAL SAFETY RULES	3
FLOORS	4
RESILIENT FLOORS	4
MASONRY FLOORS	10
WOOD FLOORS	13
CLEANING FLOORS	16
DAILY FLOOR CLEANING	18
LIGHT MOPPING	19
STRIPPING A FLOOR	22
SEALING RESILIENT AND MASONRY FLOORS	25
APPLYING WATER EMULSION FLOOR FINISH	28
DRY CLEANING A FLOOR BY BUFFING	31
SPOT WAXING	32
SPRAY WAXING	34
CARPET CLEANING	36
OIL TREATING OLD LINOLEUM	39
PROTECT FLOOR AND FURNITURE	40
SANDING A WOOD FLOOR	41
FINISHING WOOD FLOORS - Penetrating Finish	44
FINISHING WOOD FLOORS - Surface Sealer	47
REFINISHING WOOD FLOORS - Sealed Finishes	50
REFINISHING OR REFURBISHING OILED WOOD FLOORS	52
MAINTENANCE OF GYMNASIUM FLOORS	55
RESTROOM CLEANING	57
CLASSROOM CLEANING	66
CLEANING CORRIDORS, STAIRS	70
CAFETERIA CLEANING	72
CLEANING THE AUDITORIUM	73
WINDOW CLEANING	75
CEILING CLEANING	81
WALL CLEANING	84
CLEANING LIGHTING FIXTURES	87
CLEANING VENETIAN BLINDS	91
CLEANING WINDOW SHADES	93
CLEANING FURNITURE	94
CHALKBOARDS	96
TACKBOARDS	101

	Page
CLEANING THE BUILDING EXTERIOR	103
SUMMER CLEANING PROGRAM	105
INSPECTING SCHOOL PLANT FOR MAINTENANCE NEEDS.....	107
WINDOW REPAIRS.....	110
CUSTODIAL EQUIPMENT AND MATERIAL STORAGE.....	112
EFFLORESCENCE.....	122
REMOVING STAINS FROM MASONRY.....	123
SEWAGE DISPOSAL SYSTEMS	128
SEWAGE TREATMENT PLANTS	131
THE WATER SUPPLY SYSTEM	133
GARBAGE DISPOSAL	135
PEST CONTROL.....	137
GROUNDS CARE	141
UNIT VENTILATORS.....	145
ELECTRIC MOTORS.....	147
CIRCUIT BREAKERS	149
BOILER ROOM CARE.....	151
CARE AND OPERATION OF HAND FIRED UP-DRAFT BOILERS	153
CARE AND OPERATION OF HAND FIRED DOWN-DRAFT BOILERS	155
CARE AND OPERATION OF STOKER FIRED LOW-PRESSURE BOILERS	157
STARTING THE HEATING PLANT.....	158
OPERATION OF OIL AND GAS BURNER HEATING PLANTS.....	160
BOILER AND MAINTENANCE OPERATING LOG.....	162
BIBLIOGRAPHY.....	163

THE PURPOSE OF THIS MANUAL

This manual is written to and for public school custodians and plant operators. A secondary purpose is to help those school administrators who work with custodians and assist in school plant operations gain insight and knowledge. The great need for assistance to custodians throughout the state has prompted the writing of this manual. It is aimed at the local school situation where the custodian may have neither the opportunity for any formal training nor experienced personnel available to instruct him.

It was intended that this manual be written in a language that anyone could understand, briefly stated, and to the point. The topics selected are those that were thought to be of the greatest need and value. While methods of school plant operations will vary from district to district and from school to school, it is hoped that much of the material included will be of value to each custodian. The experienced custodian has doubtlessly realized that his is a rapidly changing occupation due to new methods and materials being developed. He must be seeking new ways and more knowledge. Whether the custodian has long experience or is new to the job, it is hoped that this manual will help him to help himself.

HAROLD K. DOANE, Supervisor
Division of Buildings and Grounds

CHARACTERISTICS OF A GOOD CUSTODIAN

The school custodian is entrusted with what is usually a community's largest single investment - its school plants. But the responsibility doesn't stop with the care of the physical plant; it includes the safety, health, and comfort of all persons who use this plant. A good custodian cannot be merely a good sanitarian, a good maintenance man, or a good public relations man. He must be all of these and more. A custodian who is fully meeting his responsibility is a man of many talents. The importance of the school custodian is probably under-estimated more by custodians themselves than by others. The good custodian believes in himself and he believes in his job. If he has a personality that attracts the respect and appreciation of his fellow workers and students, he will find they are more likely to cooperate in the work that he is doing.

The good custodian has many characteristics. Some of these are listed as follows:

He believes in himself and he believes in his job.

He is dependable and punctual.

He is loyal to his school and his fellow workers.

He is fair, friendly, and impartial in his dealings with others.

He is courteous and pleasant.

He has no objectionable habits.

He is a peaceful and loyal citizen in the community.

He wears conservative clothes that are in keeping with his work and keeps them clean and neat as is practicable.

He gives daily attention to his own cleanliness and appearance.

He seeks new and better ways of doing his job; and when he finds them, he puts them into practice.

He realizes that he is an example to many children, and he tries his best to be worthy of their trust.

GENERAL SAFETY RULES

Know your fire extinguishers. Read the directions on each type, and now is the best time to do it. It may save your life or that of your pupils. Know which extinguisher to use on various fires, especially electrical fires. One may be electrocuted by using the wrong extinguisher on an electrical fire. Extinguishers should be checked, recharged as needed, and tagged each year.

Keep exit doors free of chains, locks, or obstructions while students or visitors are in the building. Keep passageways free of obstructions.

Keep heating and electrical equipment in good working condition. The custodian can make many minor repairs himself; but for those he cannot do, he should promptly make a written request for maintenance department assistance. (It is helpful to keep a carbon copy of such requests.)

Dispose of trash and debris daily by burning in an incenerator or by daily collection.

Don't let any area of the school become a "catch-all" for items of little or no value.

Flammable liquids such as gasoline, mineral spirits, lacquer thinner, paint thinner, turpentine, kerosene, and alcohol should not be stored in a school if it can be avoided. If they are absolutely necessary, they should be kept in safety cans stored in locked and ventilated storerooms or in locked metal cabinets.

Oily rags and dirty dust mop heads should be laundered or burned if they have no value; but while they are waiting to be laundered, they should be kept in tightly covered metal cans.

FLOORS

Floors are the custodian's showcase. With the exception of the building exterior, probably no other area of the school plant shows the quality of the custodial staff as conspicuously as the floors. The visitor sees the corridor floors immediately upon entering the school. His opinion of the whole school is at that time beginning to formulate. It is so important that we build good public relations and create a good image.

If a good image is to be created with clean floors, the custodian will need to know floors and floor cleaning techniques or he will work himself needlessly hard. The quality of floor maintenance will improve as the custodian improves his knowledge and skill.

RESILIENT FLOORS

There are several kinds of materials which fall into the category of resilient floors, and more and newer materials are constantly being developed. Some of the materials now in use are asphalt tile, rubber tile, vinyl, vinyl asbestos, linoleum, and cork. There are others not commonly used in school; but if information is desired, it can usually be obtained from the manufacturer or the manufacturer's associations.

ASPHALT TILE

Asphalt tile is the most common resilient floor covering in use. It has a very reasonable initial cost and gives good service if properly maintained.

It consists of asphalt or resin binder, limestone, asbestos fiber, coloring pigments and other fillers. It is bound to the sub-floor with a cement or mastic. This cement must be of the waterproof type if applied to grade or below grade floors. It is of great importance to use waterproof cement to avoid future problems resulting from cleaning water damage. Water should not be allowed to stand on floors any longer than necessary.

SOME NOTABLE CHARACTERISTICS OF ASPHALT TILE ARE:

Cost: Asphalt tile may have the lowest initial cost of any floor material.

Hardness: Asphalt tile is harder than other resilient materials.

Water Resistance: Asphalt is desired for below grade or "slab" installations. With waterproof mastic, this tile adheres well and wears well in damp locations.

Brittleness: Although the hardness is sometimes desired, this may reach a point of undesirable brittleness.

Scratches: This tile may be scratched, dented, or chipped rather easily.

Solvent damage: Gasoline, turpentine, oils, grease, and solvent wax are harmful. They will soften and attack the asphalt.

Alkali or Caustic damage: Asphalt tile will show shrinkage, hardening, and drying appearances when exposed to harsh alkaline or caustic materials.

VINYL FLOORING

These materials give us excellent flooring and require a reasonable amount of care. It has been said by some that vinyl does not need waxing or finishing. This is not true; any floor needs care and protection.

Vinyl tile is a thermo-plastic material consisting of fillers and stabilizing ingredients bound together with resins.

There are three types of vinyl: (1) homogeneous vinyl, (2) laminated or backed vinyl, and (3) vinyl-asbestos.

The homogeneous tile is solid; that is, the materials and colors are the same from surface to surface.

The laminated or backed vinyl consists of vinyl glued to a backing of foam rubber, plastic or similar materials. This laminated flooring may be an inferior or superior product, depending mainly upon whether the vinyl surface thickness is the same or less than a regular homogeneous tile. This backed vinyl is produced in sheets or rolls as well as in cut tile.

Vinyl asbestos is very similar to asphalt tile in appearance and, like asphalt, it becomes brittle with low temperatures. Otherwise, the two are very different in many ways. To test a floor to determine whether it is vinyl or asphalt, rub a dark tile with a white rag dampened with gasoline. If the tile is softened and shows on the rag, it is asphalt. Vinyl-asbestos

is very resistant to temperature change and sunlight damage. Vinyl-asbestos is used to give oil and grease resistance.

SOME CHARACTERISTICS OF VINYL FLOORING MATERIALS ARE:

High resistance to water, acids, alkalies, grease, and oil; but a vinyl floor can be damaged by these liquids seeping into joints and damaging the cement and sub-floor.

Vinyl is available in wide color selections in light colors not available in some other materials.

High resistance to denting.

Vinyl is quite flexible.

Vinyl may be installed below grade if proper cement is used.

New vinyl is usually coated with a silicone during manufacturing so it must be scrubbed away before sealing and waxing.

New vinyl will sometimes resist satisfactory waxing. This condition is temporary and improves with age and use.

Steel wool use should be held to a minimum but may be used for stubborn soil.

Solvents may be used for spot cleaning of stubborn stains and marks. Use any solvents sparingly and allow none to seep into joints. Any use of solvents will remove the wax and sealer, as well as the soil. The area should be thoroughly rinsed after using any solvents.

LINOLEUM

Linoleum is the oldest of resilient floors, dating back a hundred years.

It has several peculiarities which are explained by the ingredients used.

It is composed of wood fibers, cork, pigments, gums, and linseed oil. This

composition is applied to a burlap or cloth backing. The linseed oil content is the principal cause of some of the problems of linoleum use.

New linoleum is coated with finish and polish that seals and protects the surface. Cleaning and traffic will remove this protection; and as it wears away, it must be replaced with a floor finish to maintain moisture protection.

Linoleum care and cleaning differs from that of other resilient floors in several ways. Linoleum gives good service without undue hardships on the custodian if certain precautions are taken and if the custodian understands flooring materials.

A new linoleum floor should be cleaned only with dry methods for at least two weeks. A light mopping and dust mopping thereafter should take care of most cleaning problems, but a thorough scrubbing and striping will eventually be necessary.

It must be remembered that linoleum will be damaged by excessive use of water, soaps, or alkalies. If the custodian keeps these facts in mind, the usual methods of resilient floor care may be used. A good general purpose detergent should be used.

No shellac, varnish, or lacquers should be used on linoleum. Some important characteristics of linoleum are:

High resistance to shrinkage if water and alkalies are used cautiously.

Good insulating qualities and noise control.

Wide range of color and pattern selection.

Daily cleaning is rather easy if the linoleum is properly treated.

Linoleum has some resistance to oil and grease but may be discolored and damaged.

Linoleum is soft and easy to walk on.

Good resistance to sun-caused problems of fading, discoloration, and shrinking.

Good lasting qualities. When well cared for, linoleum may be expected to last many years.

Susceptible to water damage.

Susceptible to alkali damage. Alkali and water create a soap when they unite with the linseed oil in the linoleum and result in softening.

Linoleum is easily damaged by sharp objects. Indentations are readily formed if small casters and glides are used on furniture.

RUBBER TILE

With the development of synthetic rubber came the rise of rubber tile popularity. This tile attained high status in consumer acceptance, but the vinyls have recently captured much of rubber tile's popularity.

The cleaning of rubber flooring is similar to the cleaning of several other resilient materials, but just as each material differs in its makeup and content, so do the cleaning methods vary. A new rubber floor, like other resilient floors, should be swept or dust mopped for the first week to two weeks. No wet mopping or scrubbing should be done during this break-in period.

Rubber tile possesses several traits which should be considered:

A rather high resistance to acid and alkalies.

High sound proofing qualities.

Reluctance to slippery conditions.

High resistance to denting.

Available in wide color selection.

Available in tiles, rolls or sheets, and strips.

Susceptible to sunlight damage, resulting in chalking and loss of gloss.

Susceptible to air damage which results in drying out, chalking and cracking.

May be damaged by oils, greases, oily sweeping compounds, kerosene, turpentine, gasoline, and other solvents.

Strong "fast-acting" cleaners, alkalies, and caustic cleaners will cause hardness, brittleness, and a general lifeless condition.

Cost of rubber tile is generally higher than some other resilient tiles.

MASONRY FLOORS

When discussing resilient floors, we are speaking of reasonably soft materials. Hard floors, excluding wood of course, refers to non-resilient materials all of which have cement as a principal ingredient.

Cement is not indestructible. A good understanding of cement by the custodian will make his job easier and the appearance of hard floors more satisfying.

CONCRETE FLOORS

There are probably more square feet of concrete floors in use in our schools than any other floor material. There are many, many acres of concrete which are covered with various flooring materials such as wood, resilients, and ceramics. In many spaces in our schools concrete, itself, is the most desirable material for the finished floor. For the reasons of economy of installation and durability, concrete has held high favor with public schools. Many areas in the schools need a floor that is durable, withstands heavy traffic, is non-slippery, economical, and is waterproof. Concrete meets these requirements well.

For appearance, durability, and ease of cleaning, concrete floors should be sealed with a clear, non-pigmented, penetrating sealer. The proper sealer is commonly referred to as a "terrazzo sealer." After sealing, concrete floors may be finished and cleaned about the same as other floors. Waxed masonry floors have sometimes been slippery in past years. This may have been due to the wax or finish used rather than the fault of the concrete or other masonry floor. Newer finishes are being made which are non-slippery.

TERRAZZO

The mentioning of terrazzo floors in the presence of owners invites various and often conflicting comments. This results from a lack of understanding of terrazzo and the proper care it needs. To obtain full value from this floor, the owner and the custodian must understand it.

Terrazzo is composed of a mixture of marble chips and Portland Cement. The terrazzo surface will show about three fourths marble and one fourth cement. Understanding these two materials will help one to understand terrazzo. Several points of importance when discussing terrazzo floors are:

Terrazzo floors must be sealed. They should then be finished as other floors with two or more coats of floor finish. They may be treated with the same methods used on resilient floors.

The initial cost is high, but it has long life expectancy and beauty, and a reasonably low maintenance factor presents economy factors.

Many people are under the false impression that terrazzo needs no protection or care.

Marble is non-porous and absorbs very little, but the Portland Cement is porous and absorbs stains and soil readily. The cement, then, needs to be sealed.

All acids are harmful to terrazzo.

Particles of steel wool or other steel items which remain on terrazzo and marble floors will cause rust stains which cannot easily be removed. Therefore, do not use steel wool on terrazzo.

Efflorescence is a condition occurring on new terrazzo as chemical actions take place within new cement. The efflorescence (or salts) shows up on the surface as a white or gray powder. This condition will also occur if improper cleaners, such as cleansers containing inorganic salts, are used. A good penetrating terrazzo sealer will prevent efflorescence.

CERAMIC TILE

The use of ceramic tile is an ancient art. It was used in Egypt thousands of years ago. Improvements have been made in materials and manufacturing, giving us a durable, attractive, and easy to clean floor and wall material.

Little needs to be said about the advantages and disadvantages of ceramic tile, as these are well known. Whether the owner will be satisfied with the investment in this material will depend upon the workmanship of installation and the skill of the custodian thereafter.

Ceramic tile needs about the same care that terrazzo demands, and for about the same reasons. Tile joints are Portland Cement and need a sealer to protect them and to make cleaning easier. Anything harmful to concrete will be harmful to tile joints. Therefore, it is necessary to avoid strong acids and crystal-forming cleansers and alkalies. A good sealer will help prevent damage from these and other materials.

Newly installed ceramic tile usually needs washing with a mild muriatic acid solution to remove cement stains and enhance the tile color.

WOOD FLOORS

For simplicity's sake, the discussions about wood floors in schools will be divided into two categories: gym floors or any wood floor where a deep surface finish is desirable, and other floors, such as classrooms and corridors, where a penetrating finish rather than a surface finish is desired.

The gym floor demands a finish that is tough, elastic, attractive, and non-slippery. The gym floor should never be waxed; therefore, the original finish should be of such quality and depth to eliminate any need for wax or similar coating.

The classrooms, on the other hand, should not have a glossy, light-reflecting floor. The penetrating finish offers a more satisfactory surface in classrooms. There is less light glare and traffic streaking. The penetrating finish, properly applied and maintained, offers the custodian a reasonably easy-to-clean floor.

A finish is applied to wood floors for three reasons: durability, beauty, and ease of cleaning. Whatever the use to which a wood floor is put, a finish will increase its life and durability. Wood is susceptible to water damage and staining. Both faults are lessened when a good finish is applied. The natural beauty of wood is enhanced by a finish which brings out the color and grain structure of the wood itself. The custodian is especially interested in the cleaning aspects of the floor. A good finish provides a good cleaning surface by preventing the soil from getting into the pores and cracks of the wood. A finish will permit a mopping or washing which, if carefully done, will not damage the wood.

The time and effort required to clean and maintain a wood floor is dependent on the quality of finish. Therefore, it is essential that wood floor care start with a properly applied finish.

Wood floors, except on the gym playing area, should be stripped or scrubbed each summer, sealed with two coats of penetrating wood floor sealer (if not already properly sealed), and then given two or three coats of floor finish. Thereafter, the wood floor may be cleaned and maintained with methods used on other floor materials. Common sense dictates that

excessive use of water may cause some harm to a wood floor. A good scrubbing is necessary and "flooding a floor" is never necessary, regardless of the type of floor.

If a wood floor is badly worn to the point where sanding and refinishing is needed, see the appropriate instructions given elsewhere in this manual. Specific information is given for gym floor care.

CLEANING FLOORS

The following recommendations cover the cleaning operations of stripping, wet mopping, and dust mopping of resilient floors, masonry floors, and wood floors. These different floor materials will naturally require slightly different cleaning methods, but, in general, one set of instructions will apply to all of these.

Most soft floor materials, when new, will present a small problem which will fade away with use. This is caused by the "tooth" or roughness resulting from its manufacture and, also, some materials such as wax or silicone applied during manufacture. Scrubbing newly installed floors is discouraged until the floor has been in place for a couple of weeks, but then the floor should be cleaned before proceeding to apply finishes.

All floors in public schools except the gym floor will require stripping of the old wax and dirt and refinishing once yearly to several times each year, depending on the use and conditions. A classroom or office area carefully used may get by satisfactorily with one stripping and rewaxing during each summer. The much-used corridors will require refinishing much more often. Good entrance mats, frequent dust-mopping, and student and faculty cooperation will greatly reduce the frequency of stripping and rewaxing. Buffering, wet mopping, and spot waxing periodically in heavily used areas will reduce the need for stripping also.

A brief outline of yearly care of floors is as follows:

1. During the summer, completely strip, seal if needed, and rewax all floors except the gym.

2. Dust mop all areas daily and all corridors three times daily. (After school begins each morning, after lunch, and after rooms are cleaned in the evening.) Heavily-traveled areas must be dust mopped much more often.
3. Wet mop heavily soiled areas as needed.
4. Occasional buffing with the floor machine renews the floor appearance and will remove much soil and scuff marks.
5. A badly worn area may be waxed as needed by spot waxing or spray waxing without removing all the old finish and sealer, if carefully done. Avoid over-waxing, which creates wax build-up, especially around the edges of floors, under lockers, in closets, etc.

DAILY FLOOR CLEANING

Probably the most important characteristic of a good custodian is persistence. This is a characteristic so necessary in good floor care. The custodian who is determined to keep his floors in top shape will need to be persistent. He will be confronted by many obstacles and discouraging situations and will have many excuses to lessen his determined efforts. If he will establish a high goal of floor care and persistently drive toward this standard, the total work expended may be no greater than a lower standard. A high standard, maintained by unswerving daily work, will often reduce the need and frequency of upgrading jobs such as stripping, rewaxing, scrubbing, and the like.

1. Clean all floors at least once each day with a treated dust mop. Use a floor brush in heavily soiled areas such as shops, then dust mop. Dust mops should be treated with a non-oily mop dressing.
2. School corridors should be dust mopped after school begins in the morning, after lunch, and after classrooms are cleaned in the evening. Also, run the dust mop after any large groups have entered the building, bringing in dust or dirt.
3. Heavy wet soil may be removed with brooms, mops, or wet vacuums, depending on situations.
4. Clean entrance mats frequently.
5. Remove gum and related deposits of soil with a putty knife. The good custodian should have his putty knife in his pocket at all times.

LIGHT MOPPING

If the floor has been thoroughly cleaned, sealed, and waxed, the daily cleaning and spot work becomes much easier. All the hard work of stripping and refinishing the floor is never lost and will repay the custodian many times by reducing routine cleaning work.

Getting ready to mop a small area is often half the job. The custodian who has good organization and methods in storing his equipment and supplies will reduce the total work load greatly by eliminating the many unneeded trips to and from storerooms.

To remove soil accumulated in heavily used areas which the daily dust mopping will not remove, clean as follows:

1. Assemble Equipment:

Mop bucket and wringer (2)	Counter Brush
Mops, wet (2)	Putty Knife
Dust Mop	Detergent, general purpose
Dust Pan	Floor machine and buffing pad
	Measuring cup

2. Apply Solution:

Mix and apply a mild to medium strength solution. Too strong a mixture will increase the work by removing some of the protective finish.

Always mix solutions accurately.

SEE USING THE WET MOP

3. Remove solution with vacuum, or mop if the area is small.

4. Rinse:

Rinse the area thoroughly. Any remaining cleaning solution will create more work.

Pick up rinse water with the vacuum or the rinse mop, if the area is small.

5. Buff the floor when the area is dry.

6. Care for Equipment:

Wipe floor machine and store. See STORAGE OF EQUIPMENT.

Wash buffing pad as needed.

Rinse and wipe buckets and wringers.

Wash and rinse mops, fluff the heads, and hang up.

USING THE WET MOP

This procedure may be used when applying liquids such as strippers, cleaning solution, sealers or floor finishes.

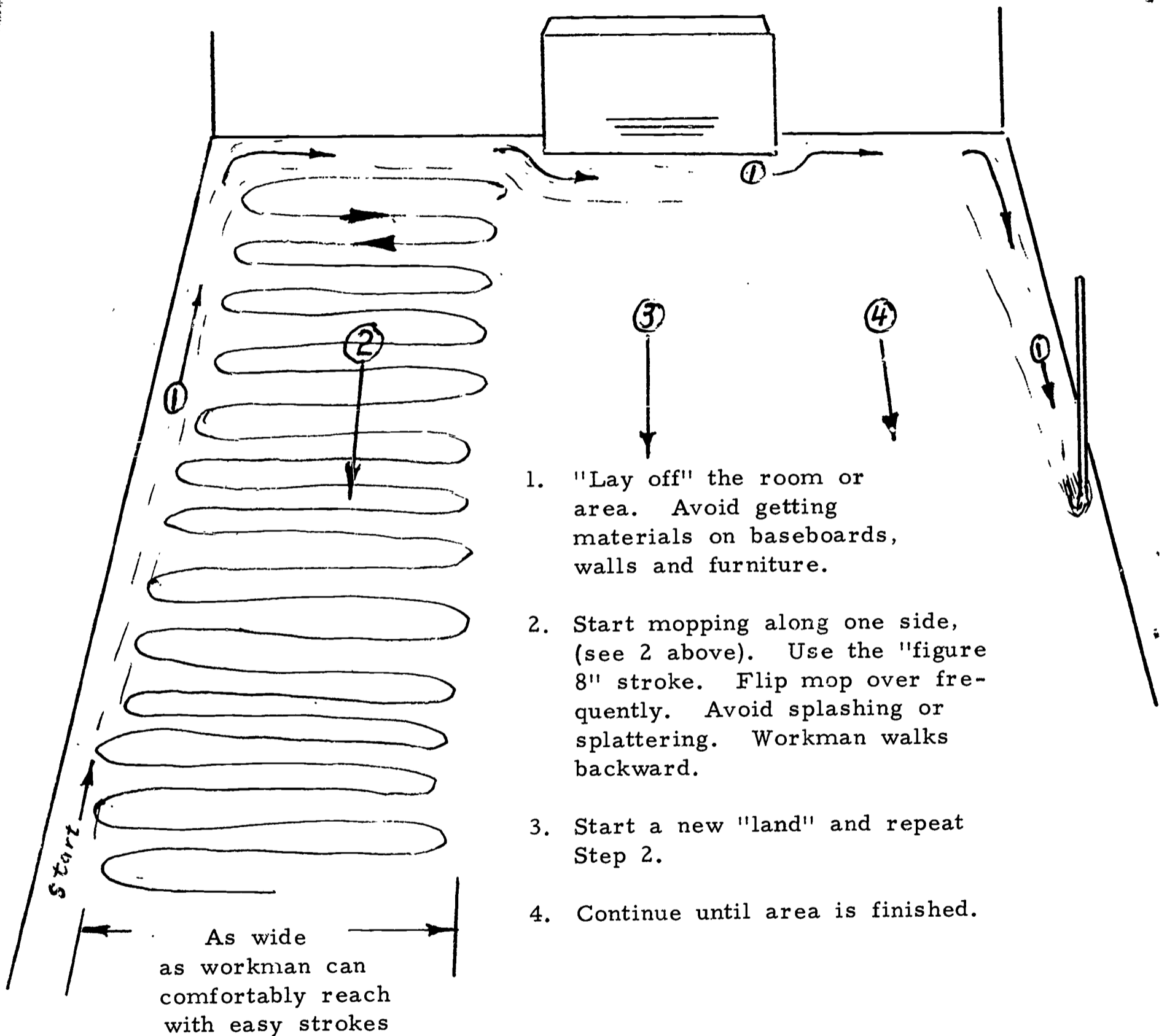

1. "Lay off" the room or area. Avoid getting materials on baseboards, walls and furniture.
2. Start mopping along one side, (see 2 above). Use the "figure 8" stroke. Flip mop over frequently. Avoid splashing or splattering. Workman walks backward.
3. Start a new "land" and repeat Step 2.
4. Continue until area is finished.

STRIPPING A FLOOR

A thorough cleaning involving the complete removal of all old finish is called "stripping." This operation should be done not less than yearly in all areas of the school and several times in corridors and much used areas.

Stripping is a thorough scrubbing process that removes not only the soil but all floor wax as well. On floors that have not been sealed, stripping will remove all wax and soil down to the bare floor. When stripping a sealed floor, the sealer will not normally be removed.

Stripping differs from machine scrubbing in two respects. When stripping a floor, a "wax stripper" is used that has the ability to remove waxes and synthetic finishes. When stripping, we want to remove all wax and soil. When scrubbing, we do not want to remove floor finishes or waxes but merely to clean the floor. For scrubbing, a general purpose detergent would be used rather than the stronger stripper. After scrubbing, it is often necessary to apply a coat of wax because the scrubbing plus heavy traffic would have worn the wax away.

In preparing to refinish a floor, all furniture should be removed from the room or pushed to one side. Stripping can best be done as a three-man operation. The needed equipment and supplies should be assembled and the room swept and dust mopped.

1. Assemble equipment and materials needed:

Floor machine with scrub brushes or steel wool pads or abrasive pads

Pad Holder
Wet/Dry Vacuum
Mop Buckets (2)
Mop Wringers
Wet Mops (2)
Steel Wool Hand Pads
Putty Knife

Floor Brush
Dust Mop
Counter Brush
Dust Pan
Stripping Solution
Measuring Cup
Overshoes

2. Mix Stripping Solution

Don't guess at proportions. Mix all solutions exactly according to an expert's instructions or the manufacturer's recommendations. Use a measuring cup whenever mixing solutions.

3. Apply Solution

Apply the cleaning solution liberally to the floor, but don't drown the floor.

Apply the solution to an area that can be scrubbed without drying during the cleaning operation, about 200 square feet.

4. Scrub

Move the machine slowly but without stopping.

With practice, the machine may be used to move the cleaning solution along the floor.

For hard to remove spots, heel the machine. This will put more pressure on the pad.

Wash scrubbing pads periodically before they become clogged with soil and old wax.

Hand scrub the areas the machine cannot reach. Use steel wool or a piece cut from an old abrasive machine pad.

5. Pick Up the Solution and Soil

Use a wet/dry vacuum or a floor squeegee and pick-up pan.

Do not allow the solution to dry on the floor.

6. Rinse Thoroughly

Use large, clean mop and clean water.

Rinsing is a diluting process and cannot be done well without adequate water and mopping action.

Keep rinse water clean.

Pick up rinse water with the vacuum, squeegee and pan, or mop.

A rinse mop should be used only for rinsing.

Any cleaning solution left on the floor will result in a poor finish and more work for the custodian.

7. Dry the Floor

Allow the floor just stripped and cleaned to dry completely. Keep traffic off the area until completely finished.

8. Is the Floor Clean?

It is definitely a waste of time, labor, and materials to attempt to apply a finish to a dirty or improperly cleaned floor. After the above stripping operation, the custodian should take several steps to determine if the floor is really clean. He should look carefully for shoe marks and rubber burns, chewing gum, paint or ink drippings, etc. The edges of the floor area should be examined for wax build-up. All the old finish should be removed. Rubbing an area with a clean steel wool pad should indicate presence of old finish. Spot clean any remaining soil and old finish and rinse thoroughly. Failure to rinse well with clean and frequently- changed rinse water will contribute to future troubles.

9. Care for Equipment

Floor machine - Wipe machine and cord. Remove brushes and pads. Coil the cord and store the machine. Never store with the machine resting on the brush or pad. Rinse brushes and pads and store properly.

Wet/Dry Vacuum - Empty the tank, rinse it, and wipe inside and out.

Wipe machine power unit and cord. Wipe all accessories. Put the motor back on the tank, fasten it, and run the motor for three minutes. This will remove moisture from the motor.

Mop Buckets - Empty, wash, and rinse mop buckets and wringers. Wipe dry and store properly.

Mops - Wash, rinse, squeeze out water, fluff the mop head and hang up to dry. Rinse wax mops immediately after use.

Dust Mops - Brush the heads with a stiff bristle brush and hang up.

Floor Brushes - Shake well. If wet or dirty, they may be washed, rinsed, and hung with the bristles down to dry.

Clean other equipment and materials and store in an orderly manner. A custodian is judged by the way he cares for his equipment and materials. Keep things in a particular place.
A PLACE FOR EVERYTHING - EVERYTHING IN ITS PLACE.

SEALING RESILIENT AND MASONRY FLOORS

Sealing is the first step in applying a floor finish, assuming the floor is thoroughly clean and free from any old finish and dirt. A sealer is to a floor finish what a primer is to house paint. A sealer prepares the floor for future coatings by sealing and filling the pores and joints. This will give more depth to finish coats and aids in future cleaning by separating the floor from the dirt, scuff-marks, and dirty and worn wax. A good sealer, properly applied, should repay the custodian many times by making cleaning and rewaxing easier.

In selecting a sealer, one should purchase a sealer designed for the floors on which it will be applied. A water emulsion sealer may be used on masonry floors and resilient floors. A solvent sealer may be used only on masonry floors. Solvent sealers may not be used on soft materials such as asphalt, vinyl and rubber. Sealers for wood floors are of another type and are discussed elsewhere in this manual.

The equipment and methods of applying resilient floor sealers and masonry sealers is very similar in method and are, therefore, jointly considered in the following procedures.

A sealer is valuable in areas where frequent wet mopping or scrubbing is done. The scrubbing and mopping will remove some of the water emulsion waxes and synthetic finishes, but sealers are not as easily removed.

Sealers are valuable in reducing dusting problems on masonry floors. They help to prevent water, soil, and cleaning solution penetration into the floor.

Sealers should not be applied indiscriminately or frequently. Some authorities suggest that a coat of sealer properly applied in a thin coat to a clean floor might not need to be repeated for a long time, if at all. There are some resilient floors being kept in good condition without a sealer. All terrazzo and concrete floors should be sealed soon after installation.

PROCEDURE:

1. Prepare for sealing

The floor must be clean and dry.

2. Assemble needed equipment and materials

Mop bucket and wringer, clean

Mop, wet, new or clean

Sealer, Terrazzo

or

Sealer, resilient floor

3. Apply the sealer. Follow manufacturer's instructions.

Dip the mop in water and wring dry (water emulsion sealers.)

Saturate the mop or applicator in sealer and wring lightly.

Apply the sealer lightly and evenly. Feather the laps.

Take care not to get sealer on baseboards, door frames, and furniture.

4. Let the sealer dry.

5. Apply a second coat, if needed, on dried out or porous floors.

6. Care for equipment

Clean equipment with the proper solvent or thinner when using solvent sealers. (See manufacturer's instructions.)

Clean equipment with water when using water emulsion sealers.
Wash mop immediately, shake out, and hang to dry.
Keep this mop for applying sealer only.
Clean buckets and wringers

APPLYING WATER EMULSION FLOOR FINISH

This discussion refers to and includes these water emulsion floor finishes commonly called floor waxes. They may be true carnauba waxes or synthetic waxes. There are several finishes which fall in this broad category and each may have slightly different recommendations and application instructions by its manufacturer.

The school custodian should have good results from either type finish if it is a good quality product. The manufacturer's instructions should be consulted.

The custodian will find the carnauba waxes should be buffed after each coat is applied. The synthetics usually should not be buffed until they have dried for a few days.

These water emulsion finishes may be applied to most all floors normally found in schools, except gym floors.

PROCEDURE:

1. Prepare for waxing
The floor should be clean, dry, and sealed.

2. Assemble equipment and materials:

Mop bucket and wringer, clean.

Mop, wet, clean.

Floor finish.

3. Apply the finish

Dip the mop in water and wring dry.

Dip the mop about two-thirds into the wax and wring lightly.

Apply the wax lightly and evenly over all the floor except the few inches next to the walls and under lockers and permanent furniture. See NOTE below:

Follow the methods shown on USING THE WET MOP.

4. Let Wax Dry

If a carnauba wax finish is used, each coat should be buffed. If synthetic finish is used, buffing each coat is not recommended.

5. Apply Second Coat

Apply the second coat to within three or four inches of walls and permanent furniture.

6. Let Wax Dry

Buff if needed. See Step 4

7. Apply Third Coat

Apply third coat up to walls and permanent furniture. Keep wax off woodwork and furniture. Wax may be used on masonry core or base.

8. Let Wax Dry

Buff carnauba waxes after drying.
Buff synthetic finish after a few days.

9. Care for Equipment

Wash, dry, and store buckets and wringers.
Wash and rinse the wax mops. Wring it dry, fluff the head, and hang it to dry.
Use it only for waxing.
Do not put any unused wax back in the container with good wax.

NOTE: To avoid excess wax build-up, taper the thickness of wax near walls and permanent furniture. The first coat should stop six or eight inches from walls. The second coat should lap over the first to within three or four inches of walls and the third coat should be applied up to the walls. No wax need be

applied on areas such as under lockers where there will be no traffic.

Waxing in unneeded areas just creates work and trouble later. The excess wax may become discolored. Never allow the wax mop to touch walls and
woodwork.

DRY CLEANING A FLOOR BY BUFFING

This is a good method of cleaning and brightening a floor that has a wax finish. When the floor machine is used to dry buff a waxed floor, the dirt is loosened and the wax is redistributed to help cover scuffs and scratches. Much of the success of this operation depends on the quality and depth of the existing wax coating.

The custodian should schedule this operation periodically. Dry buffing every month or so will extend the life of the floor finish and help maintain the appearance. Buffing will decrease the need for wet mopping.

EQUIPMENT AND MATERIALS NEEDED:

Floor Machine

Buffing Pads

Dust Mop

PROCEDURE:

1. Dust mop the floor to remove loose soil
2. Damp mop

Damp mopping will remove much soil and also leave the floor slightly moist, which aids buffing

3. Buff floor with floor machine

Heel the floor machine to remove shoe marks

4. Dust mop the floor to pick up loosened soil or wax

5. Care for Equipment

Wipe and store floor machine
Hang buffing brush
Wash buffing pads and store

There are times when traffic wear and spot mopping will remove or wear the finish to the point where additional wax is desired but not to the extent where a complete refinishing is advisable. Foyers, entrances, and corridors which receive heavy traffic and soil often become dull and lack a protective wax film. This situation calls for "spot finishing" or "spot waxing."

EQUIPMENT AND MATERIALS NEEDED:

Wet Mopping Equipment

Mop, mop bucket, and wringer (for wax)

Floor wax

Buffing machine (when available)

PROCEDURE

1. Clean the area
Wet mop the area
Clean more than just the area to be waxed
2. Apply a wax
Apply a thin coat of floor wax to worn area. Do not apply wax unnecessarily to unworn areas as this may contribute to wax build-up. Feather the edges of the area waxed.
3. Buff the Area
Buff the newly applied wax and the surrounding area.
This will help blend the spot with older finish.
See manufacturer's instructions for the waiting time before buffing.

4. Care for Equipment

Wipe floor machine and store

Wash pads and store properly

Wash and rinse wax mop. Fluff the head and hang up
to dry

Rinse buckets and wringers, wipe dry

SPRAY WAXING

This method of floor care is popular with efficient custodians who wish to keep their floors looking nice. Spray waxing is a good technique for keeping heavily used areas in good condition. It is fast and involves a minimum of equipment. The custodian needs only a small sprayer, preferably one that can be operated with one hand. A spray waxing attachment may be purchased for the floor machine.

Spray waxing is not only a method of applying wax to needed areas, it is a cleaning technique also, and is sometimes called spray cleaning. The spray mist softens the soil and existing finish, and the buffing pad removes soil as it spreads and buffs the newly applied wax.

This technique of floor care is especially good in such places as doorways, around heavy furniture in offices, walkways, and is especially used in large areas by experienced custodians.

EQUIPMENT AND MATERIALS NEEDED

Floor machine equipped with buffing pad

Sprayer

Wax and water solution (50=50)

1. Dust mop the floor
2. Spray a light mist over a small area of 5 to 10 square feet, or less
3. Buff the area

Buff the area without waiting for the wax to dry

If the floor machine can be handled with one hand, the mist may be applied with the other.

Heel the machine to remove shoe marks.

The buffing pad should be turned over as it becomes loaded with wax and dirt.

4. Spray another small area and buff

Continue the spray and buff operation until the job is finished.

5. Care for Equipment

Wipe the floor machine and store.

Wash the buffing pad and store.

Wipe the sprayer. The wax need not be thrown out as is the case in other methods of wax application, since the wax has not become contaminated.

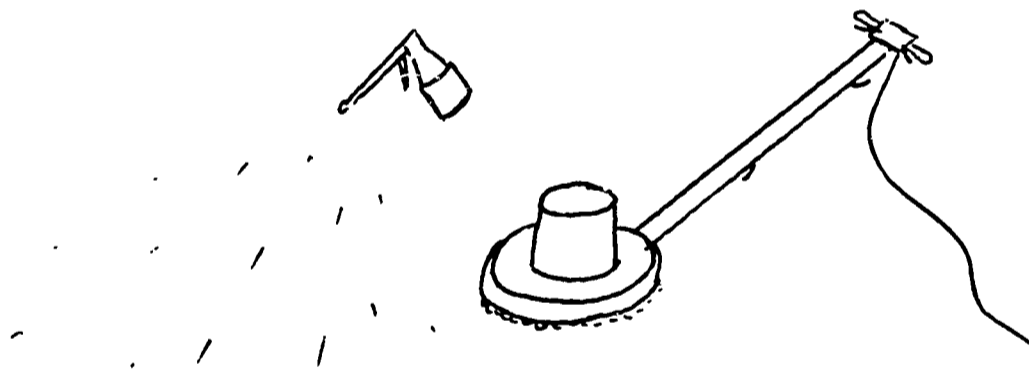

CARPET CLEANING

Carpeting is being increasingly used in schools. The acoustical advantages of carpeting is creating much interest among school planners and builders. The installation cost and upkeep factors are also the cause of much concern and controversy. The custodian will play a major role in any success of carpeting in schools.

The school custodian will need to understand carpeting and carpet cleaning. New equipment and materials used in carpet care are being developed rapidly, and with these come new methods and techniques of usage. The custodian must seek current and up-to-date knowledge as these new materials come into his occupation.

Daily care of carpets will require spot cleaning and vacuuming. Vacuuming will be the daily care with spot cleaning being done as needed. Spills and stains should be quickly blotted with towels to remove as much as possible, then a rag dampened with detergent solution may be used to remove the remainder. A damp cloth should be used to rinse the detergent. Stain removing kits are available from supply houses which will be helpful in carpet care.

An up-right carpet vacuum is needed for daily carpet care. The vacuum needs to have some type of agitating or brushing action which will aid in cleaning and loosening soil and will, also, straighten and lift the carpet pile.

A method of annual cleaning is the shampoo method. This requires a shampoo machine or an attachment for the existing floor machine. The shampoo is contained in the tank on the machine handle. It flows through the machine housing onto the shampooing brush. The shampoo is quickly changed into foam as it runs onto the revolving brush. The shampoo is not to be permitted on the carpet in its liquid state as it may damage the carpet by wetting. The foam or lather does the cleaning as the brush revolves on the carpet. Heretofore, it has been recommended that the lather and soil should be picked up with the wet/dry vacuum as soon as possible. This was best done with a man on each machine so that vacuuming could be done close behind the shampooing. Newer and higher quality shampoos have reduced the need for immediate pick-up with the vacuum. After shampooing, the pile of the carpet should be "set" or straightened with a pile setter or stiff brush. The carpet should be allowed to dry completely before allowing traffic or furniture on it. When dry, it should be vacuumed with the upright vacuum. The custodian should request a demonstration in the use of shampoos and shampooing equipment before attempting it.

Another means of periodic cleaning is done with a dry cleaning or powder cleaning method. This involves the use of a solvent-saturated powder which is sprinkled over the carpet, brushed into the pile, and removed with the upright vacuum. This method has been recommended for smaller areas rather than complete over all cleaning. The supplier's

instructions should be followed in the use of these powders, and a demonstration should be requested.

OIL TREATING OLD LINOLEUM

If linoleum floor has been exposed to strong alkali cleaners, it may show signs of drying, brittleness, cracking, and edge curling. These symptoms indicate that alkali has attacked the linseed oil in the linoleum. The following procedures improve the condition and appearance somewhat:

1. Strip the area of all wax, sealer, and soil.
2. Apply a coat of hot boiled linseed oil with a mop or lamb's wool applicator.
3. Remove excess linseed oil after two or three hours.
4. Repeat with another coat of oil if necessary.
5. Keep traffic off the linoleum for several hours until drying is complete.
6. When thoroughly dry, finish as usual.

PROTECT FLOORS AND FURNITURE WITH
PROPER GLIDES, CUPS, AND CASTERS

All light furniture such as student tables, chairs, and tablet-arm chairs should be equipped with flexible glides large enough to prevent indentation of resilient floors.

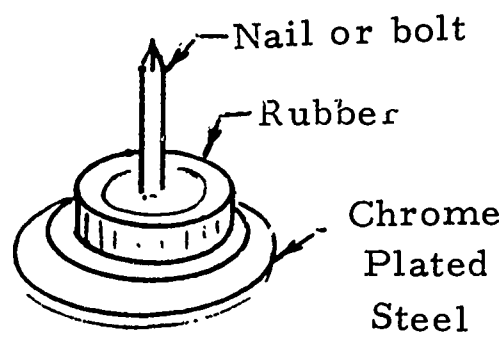

For large furniture, use large glides or rubber or plastic cups. The weight of furniture will determine the size of protective cups. A teacher's desk needs a minimum 1-1/2" glide or larger. A cup would be better if the desk is not moved daily.

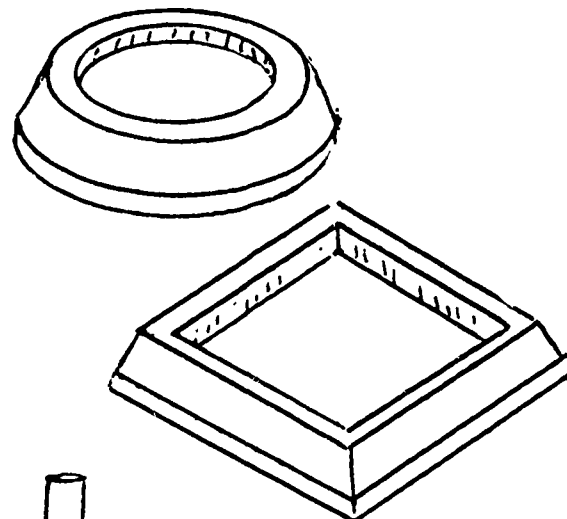

Movable furniture which must have casters should be equipped with large rubber casters having a wide bearing surface.

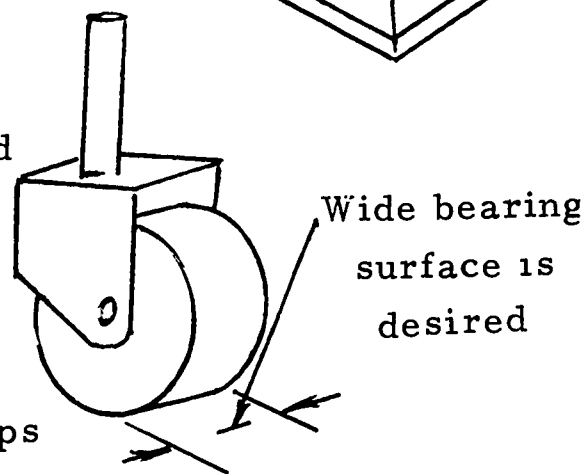

Avoid caster, glides, dome-headed nails, and caps which have small area contact with the floor, as shown below. The greater the area contact with the floor, the less friction, wear, and floor damage will occur.

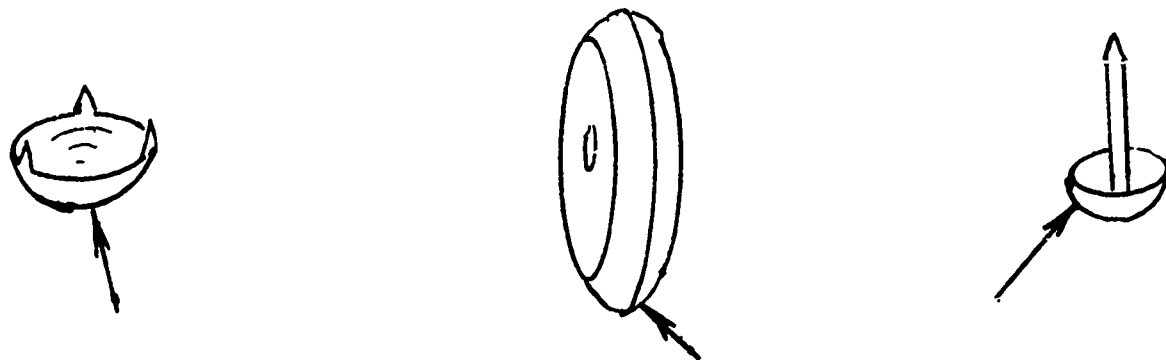

Insufficient Contact with the Floor

SANDING A WOOD FLOOR

This outline of the procedure for sanding floors is not meant to recommend that custodians should take over any of the responsibilities of the maintenance departments. There are many old wood floors which are rough and hard to clean that should be sanded and refinished. Custodians may be called upon to do this, or help do it, as part of their summer cleaning program.

MATERIALS NEEDED:

Floor sander, drum type, about 8" width, with dust bag

Paper, floor sanding (always use open coat paper when sanding an old finish), 2-1/2 grit; 1-1/2 grit, 1/2 grit, 2/0 grit

Floor edging sander, 6" disc, and paper

Floor brush

Scraper, wood, hand

Hammer, claw

Nail set, 3/32

Vacuum cleaner

Plastic wood filler

1. Prepare the floor

Remove any furniture

Remove all scraps, dust, and dirt

Set nails that are showing

2. Sand the floor with 2-1/2 grit paper

If the floor is in good condition, the 2-1/2 grit paper may be omitted.

Sand with the grain normally. Diagonal sanding is often used on rough and uneven floors.

Keep the sander in motion at all times the sandpaper is touching the floor.

Maintain a slow and even motion.

Sand about half the floor from one direction then reverse position and sand the other half.

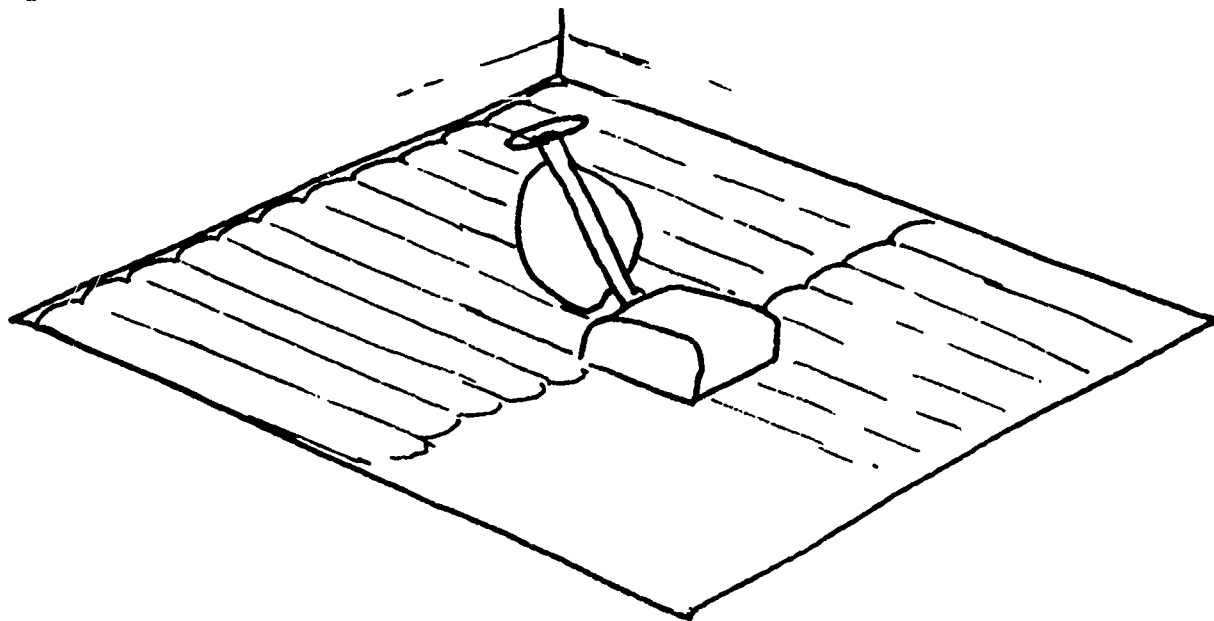

3. Inspect the progress

Examine the floor carefully for the high spots or skips. If any are found, go over these areas to even them up.

If any sander grooves or dips are seen, it is because of improper operation. The operator must have the sander in motion when the sanding drum is lowered or raised.



4. Sand the floor with 1-1/2 grit paper.

Proceed as in Step 2.

5. Sand the floor with 1/2 grit paper.

6. Sand edges and corners with floor edger and coarse paper.

Avoid cross-grain scratches as much as possible.

Scrape corners and around door jambs with a floor scraper.

7. Fill all dents and holes and over nails.

Remove all dirt and dust from holes and dents.

Fill any dents and holes and over nail heads with plastic wood filler. Most crack fillers or plastic wood materials shrink as they dry, so an allowance must be made for this shrinkage. Large holes over a quarter inch in depth should be filled in layers with drying time in between. Allow these materials to dry before proceeding.

8. Sand the floor with drum sander and 2/0 paper.

9. Sand edges and corners with edger.

Sand edges with edger and 2/0 discs.

Scrape hard-to-get-to places with wood scraper.

10. Clean the floor with a vacuum.

11. Clean equipment.

12. Select finish to be used, penetrating sealer or surface sealer.

FINISHING WOOD FLOORS--Penetrating Finish

The penetrating sealer finish is intended for use on all wood floors except the gymnasium. After this penetrating finish is applied, the floor should be waxed and maintained with about the same methods used on other classroom and corridor floors.

This procedure applies to new floors or old floors, provided each has been properly sanded smooth and are clean and dry. All nails have been set below the surface about 1/16 inch. All dents, holes, and nail-head holes should have been filled with a plastic wood filler, allowed to dry, and sanded smooth.

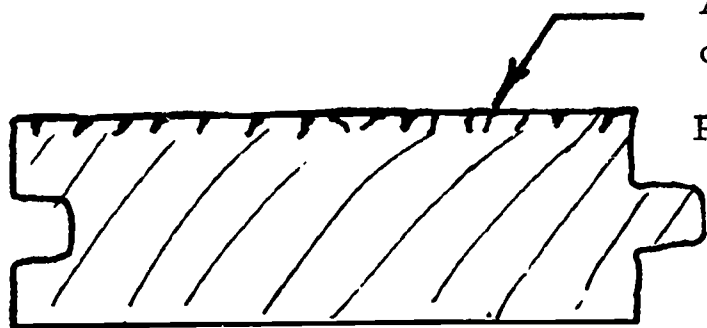

A non-glossy surface for classrooms and corridors.

Pores are sealed with thin coats of wood floor sealer.

MATERIALS NEEDED:

Vacuum

Lamb's wool applicator

Shallow Pan

Floor Machine with Steel Wool Pads

Sand paper, 2/0

Paste wood filler
(for oak and open-grain floors)

Mineral Spirits

Oil Stain, if needed

Paint brush, large

Burlap, excelsior,
or coarse rags

1. Clean the floor.

Inspect the floor for holes, dents, marks.
Avoid wearing shoes that mark floors.
Clean the floor with a vacuum.

2. Apply a thin coat of sealer.

The sealer may need to be thinned 50% to 75%. See the manufacturer's instructions.

Apply sealer with lamb's wool applicator and shallow pan.

Apply sealer with the grain of the floor.

Let dry thoroughly.

3. Sand lightly.

Remove rough grain and dust that has adhered to the sealer by sanding lightly or by using a floor machine and steel wool pads.

4. Remove dust with a vacuum.

5. Apply paste wood filler to open grain woods.

Paste wood filler is needed only on open grain woods such as oak. Paste filler is not needed on maple and pine floors.

Mix the filler to a consistency of cream. Use mineral spirits as a thinner.

If the floor is somewhat dark, or has been stained, some oil stain should be added to the filler to make it match the floor.

Apply the filler across the grain.

Apply the filler to a small area about 25 square feet at a time.

Watch for the filler to turn dull and streaked, then rub it off across grain with burlap or coarse rags. Filler is difficult to remove if allowed to dry on the surface. Filler belongs in the pores and cracks, not on the surface.

6. Apply sealer, second thin coat.

Inspect filler application. Sand out any streaks. Remove the dust.

Apply a thin coat of sealer as before.

Let dry thoroughly.

7. Sand lightly.

After the sealer is thoroughly dry, sand lightly with fine sandpaper, about 2/0, or with a floor machine and steel wool pads.

8. Apply a third thin sealer coat.

9. Apply floor wax.

After sealer is thoroughly dry, apply two coats of floor finish.

FINISHING WOOD FLOORS--Surface Sealer or Gym Finish

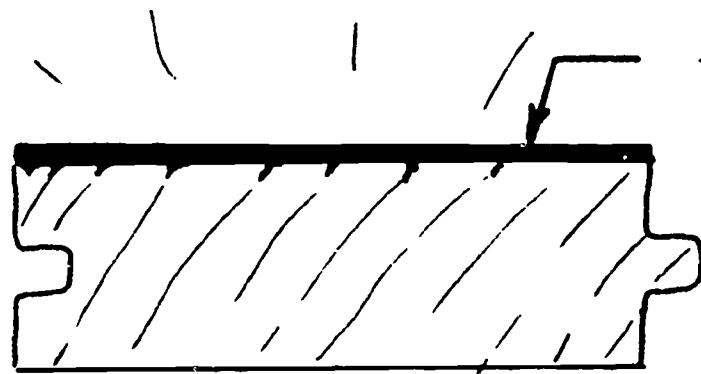

A glossy surface film built up of several coats of wood floor sealer.

This deep surface finish is used on all gym floors and sometimes in other areas. It is not as desirable in classroom areas as is the penetrating sealer finish which is maintained with wax.

This procedure applies to new or old wood floors that have been sanded smooth, are clean, and thoroughly dry. All nails should have been set below the surface about 1/16 inch. All dents, holes, or nailhead holes should have been filled with plastic wood filler, allowed to dry, and sanded smooth.

MATERIALS NEEDED:

Sealer, surface type (high solid content)

Applicator

Shallow Pan

Vacuum Cleaner

Floor Machine and Steel Wool Pads

Sandpaper, 2/0

Thinner, sealer
(see manufacturer's instructions)

In addition, the following will be needed if the floor is an open-grained wood, such as oak:

Paste wood filler

Large paint brush

Burlap or coarse rags

Mineral spirits

1. Clean the floor.

Inspect the floor for holes, dents, marks, improper sanding, etc.

Avoid wearing shoes that mark the floor.

Clean the floor with a vacuum.

2. Apply a thin coat of sealer.

Thin the sealer 50% to 75% (see manufacturer's instructions).

Apply the sealer with lamb's wool applicator with the grain.

Let dry thoroughly.

3. Sand lightly.

Sand the dried sealer coat with fine sandpaper or with the floor machine and a steel wool pad.

4. Clean floor with vacuum.

5. Apply paste wood filler to open grain woods.

Paste wood filler is needed only on open grain woods, such as oak. Paste filler is not needed on maple and pine floors.

Mix the filler to a consistency of cream. Use mineral spirits as a thinner.

If the floor is somewhat dark or has been stained, some oil stain should be added to the filler to make it match the floor.

Apply the filler across the grain.

Apply the filler to a small area of about 25 square feet at a time.

Watch for the filler to turn dull and streaked. Then rub it off, across the grain, with burlap or coarse rags. Filler is difficult to remove if allowed to dry on the surface. Filler belongs in the pores and cracks, not on the surface.

6. Apply sealer, surface coat.

Apply a sealer designed for surface finishes, such as gyms. This sealer should have a higher solids content than a penetrating finish. Less thinner is used than with penetrating finishes--see manufacturer's instructions.

Let dry thoroughly.

7. Sand lightly as in Step 3.

8. Apply sealer, second surface coat.

Apply as in Step 6.

NOTE: If court markings are to be applied, such as in a gym, they should be painted on before the last coat of sealer.

9. Sand lightly, if there is to be another coat of sealer.

10. Apply sealer, third surface coat

Apply as in Step 6.

This coat may be omitted if an adequate finish has been obtained with prior coats.

REFINISHING WOOD FLOORS--Sealed Finishes

When considering the possibility of refinishing a wood floor, one must evaluate the existing finish and floor condition to determine if the old finish should be entirely removed. If the old finish is worn and the floor has become stained, worn, and damaged, a complete refinishing beginning with sanding probably is the best solution. In this case the procedure outlined in SANDING A WOOD FLOOR should be followed. After sanding, the procedure for a Penetrating Finish or Surface Finish should be followed.

Should the existing finish show worn spots and traffic streaks but the wood floor itself is in good condition, a more economical method of reconditioning may be to clean the surface and apply more sealer and finish coats. In this case, the following procedure should help.

1. Remove furniture and equipment.
2. Clean the floor.

All old wax and soil must be scrubbed from the floor.

In general, follow procedures recommended for STRIPPING A FLOOR.

Be cautious with the excessive use of water on wood floors.

Scrub the floor with a floor machine and steel wool or abradant pads.

Pick up all soil and cleaning solution and rinse well.

Dry the floor thoroughly.

3. Examine the floor.

Determine if the floor is sufficiently cleaned. Repeat the scrubbing if needed.

If water has touched bare wood, the grain may have been raised. This will require a light sanding in these places.

A floor machine and steel wool may be adequate; in which case, go over all the floor area to remove gloss and roughness.

4. Clean the floor with a vacuum.
5. Apply the new finish.

Choose a penetrating finish or a surface finish and follow the procedures stated under FINISHING WOOD FLOORS--Penetrating Finish or FINISHING WOOD FLOORS--Surface Finish.

REFINISHING OR REFURBISHING OIL-TREATED WOOD FLOORS

It is a rather common desire of school personnel to eliminate oiled floors. It is also quite commonly believed that once the floors have been oiled, nothing can be done to remove it. This is not necessarily true. A resilient floor can be installed over the old floor by a competent flooring contractor. This will involve a cost which will need to be considered in light of the building value since most oiled floors are found in older buildings.

Some oiled floors have been sanded and given a penetrating sealer finish. The results are usually not a new floor appearance but certainly an improvement. A thorough sanding may require more expenditure than many schools wish to put forth.

A third, less expensive, method of eliminating the oil problem is to scrub or strip the floor thoroughly and apply a penetrating sealer. Some floor care experts recommend this method for schools. The procedure here is nearly the same as for stripping a resilient floor finish, with some minor exceptions. Schools having oiled floors should try this method of refinishing. It should be done early in the summer cleaning program.

EQUIPMENT AND MATERIALS NEEDED:

Floor Machine	Mop buckets and wringers (2)
Abradant stripping pads	Wet mops (2)
Steel wool pads, coarse	Wood scraper

Wet/dry vacuum

Scrub brush

Steel wool

Stripping solution

Penetrating sealer

Wax applicator

Shallow pan

Sealer thinner

PROCEDURE:

1. Remove furniture from the room.

2. Apply stripping solution.

Mix a strong stripping solution.

Keep water to a minimum but not skimpy.

Apply solution to a five-foot strip across the room.

3. Scrub thoroughly.

With a floor machine and a coarse steel wool or abradant stripping pad, scrub the floor.

4. Pick up solution.

Remove solution with a wet/dry vacuum.

Don't allow solution to stand on a wood floor after scrubbing any longer than necessary.

5. Repeating scrubbing procedure on other strips or "lands" until the room is completed.

6. Clean up the corners and edges with floor scraper, steel wool, and scrub brushes.

7. Repeat entire procedure over entire floor.

This amounts to a double stripping operation.

8. Let floor dry over night.

2

9. Examine floor.

If the presence of oil is still noticeable, another scrubbing is needed. More than likely, three scrubblings will be needed.

10. Repeat a complete scrubbing, if needed.

A waiting period of a few days between final scrubblings will allow oil that is down in the wood to rise to the surface where it may be scrubbed away.

11. Let floor dry.

Provide good ventilation and allow ample drying time.

If after drying, the wood shows raised grain (feels like whiskers), a floor machine with coarse pad should be used.

12. Apply penetrating finish.

Follow instructions given in FINISHING WOOD FLOORS-PENETRATING FINISH.

After two or three thin coats of penetrating sealer, the floor may be maintained as soft tile floors.

MAINTENANCE OF THE GYMNASIUM FLOOR

Although the gym floor is just another hardwood floor, the process of maintenance is somewhat different from hardwood classroom floors. The gym floor is finished with a surface sealer and does not have a protective wax coating. The surface sealer provides an elastic gloss film that is slip resistant but will scratch and wear under heavy traffic. The area of the floor that receives the most use will suffer the most wear and will require resealing in such areas as the wear becomes apparent. These worn areas should be cleaned with a mild detergent and allowed to become thoroughly dry before being resealed. After the sealer is dry, the area may be lightly buffed with fine steel wool to make the resealed area blend with the rest of the floor. If two coats of sealer are used, the area should be buffed with fine steel wool between the coats of sealer. If the worn areas are properly maintained, the entire floor will seldom need to be resealed.

The improper practice of resealing the entire gym floor at regular intervals causes a heavy build-up of sealer over the light traffic areas. This practice, along with the tendency to seal over soil or dirt, causes the floor to become spotted, dark, and unsightly. This dark surface film can be removed by sanding, which reduces the life of the floor, or by stripping the sealer from the floor by a chemical remover. The non-flammable type chemical remover is much safer to use and does not reduce the life of the floor. The remover should be applied in small areas and the old finish removed by a steel wire brush under the floor machine. Sawdust spread

over the stripper will assist in the removal process and simplify the cleaning. Clean each area thoroughly and sweep up all residue before resealing.

If gym floors need sanding, see SANDING A WOOD FLOOR. Then apply the finish as described in FINISHING WOOD FLOORS--SURFACE SEALER OR GYM FINISH.

It is not recommended that custodians do a complete refinishing of a gym floor, whether it be by sanding or chemical finish remover (commonly called varnish remover). This should be done by flooring contractors or maintenance departments.

Daily cleaning of the gym floor should be done with a treated dust mop which should be laundered frequently. No chemicals should be used or sprayed directly on the floor, nor should additional agents be applied over the finished surface sealer. If the gym floor is in constant use, it should be cleaned with the treated dust mop several times a day or following each gym class or activity. It may be necessary to damp mop the gym floor occasionally or even to scrub the entire area. Only mild soap or detergents should be used in this cleaning process, and excessive moisture should be avoided. Cleaning and rinsing solutions should be in separate mopping containers, and separate mops used therein. Clean only a limited area at one time, and complete the process before moving to another area. If the gym floor has been properly finished and is properly maintained by these simple suggestions, it will be no more difficult to maintain than any other hardwood floor area.

RESTROOM CLEANING

No single area of the school plant reveals the nature of the custodial program more readily than does the restroom. The remainder of the school plant may reveal excellent custodial service; but if the restroom area reveals neglect, the total program may be severely criticized. Such criticism may be unfair to the custodian as pupil supervision is a major factor in maintaining a clean, orderly restroom. Restroom sanitation thus becomes an administrative, as well as custodial, problem.

The proper care of the restroom area involves methods and materials, but these alone are not the answer to the problem. The answer involves frequent cleaning and ventilation. Cleanliness may be achieved by complete regular daily cleaning of all fixtures and soiled areas with a good detergent solution which contains a germ and bacteria killing agent. Particular care should be used in cleaning the commode at the water line, under the lip or rim, in the trap, and on both sides of the seat. Urinal traps usually build up a heavy crust of crystals and dirt that become a source of bad odors. Urinal traps and floor drain traps should be brushed out daily. All traps and drains should be flushed with a hose at least once per week. Floors should be mopped daily with the proper detergent. Harsh cleaning agents such as acid solutions and abrasive powder should not be used for regular daily cleaning, but only in extreme instances and with great care. A sponge is the most effective cleaning tool for restroom service. Both the State Department of Health and the American Medical Association advise against the use of deo-

dorants and disinfectants as being neither necessary or desirable. In most cases, it is found that deodorant blocks and sprays are used to cover up a dirty restroom. CLEAN RESTROOMS DON'T SMELL. . therefore, perfumes are not needed.

Frequent inspection and service will be necessary if the restroom area is to be properly maintained. The custodian should inspect each restroom at regular intervals throughout the day and render necessary service as soon as the need is apparent. Faulty or broken fixtures should be repaired or removed immediately and maintenance personnel advised promptly if their service is required. Pupils tend to respect a clean, orderly restroom, but have little regard for one that is soiled and untidy. Inspection will probably reveal that pupil supervision will be needed in some restrooms. The custodian will need to refer this problem to the principal, as pupil supervision is not a custodial function.

The restroom should not be used for a dressing room, shower, locker room, or for any storage purpose. The only movable item allowed is a waste receptacle for paper towels, and it should be large, open-top, steel, mesh type container. Mops, pails, brushes, ladders, etc. must not be left in the restroom at any time during school hours.

The custodian should plan the restroom service so that it can be properly observed in the daily work schedule. He should develop methods and procedures for servicing and cleaning the area so that daily or periodic cleaning services will be performed at the proper intervals and in a thorough and uniform manner. A

maid should be on the custodial staff so that the girls and ladies restrooms may be properly serviced during the day. Pupil health, public relations, and professional pride demand that the restroom service be of acceptable quality. The excellence of this service has educational implications for habits and attitudes of the pupils. It may be of a positive or negative influence upon their lives and thus offers an educational challenge to the custodial program of the school.

DAILY RESTROOM CLEANING

School restrooms should be thoroughly cleaned after each school day. During the day the restrooms must be checked several times by the custodian and maid.

MATERIALS NEEDED:

2 Buckets

Sponge

Rags, wet and dry

Detergent, sanitizing

Abrasive cleanser

Acid bowl cleaner

Long handle bowl brush

Rubber gloves

Mirror, small hand

Putty knife

Plunger or plumber's friend

2 Mop buckets

2 Wringers

2 Wet mops

Broom or floor brush

Dust pan

Trash collecting bag

SUPPLIES FOR REPLACEMENT

Towels

Toilet paper

Hand soap

Sanitary napkins

1. Remove waste

Collect all paper towels and trash.
Empty waste cans.

2. Sweep floor

Sweep dry soil, paper, etc., from the floor.

3. Clean wash basins

See Wash Basin Cleaning.

4. Clean urinals

See Urinal Cleaning.

5. Clean water closets

See Toilet Cleaning.

6. Clean walls and partitions

7. Clean mirrors and windows

8. Fill dispensers

9. Adjust ventilation

Adjust windows or mechanical ventilation as needed.
Always provide good ventilation in a restroom.
Maintain about 60 degree temperature.

10. Mop the floor

See Floors, Wet Mopping.

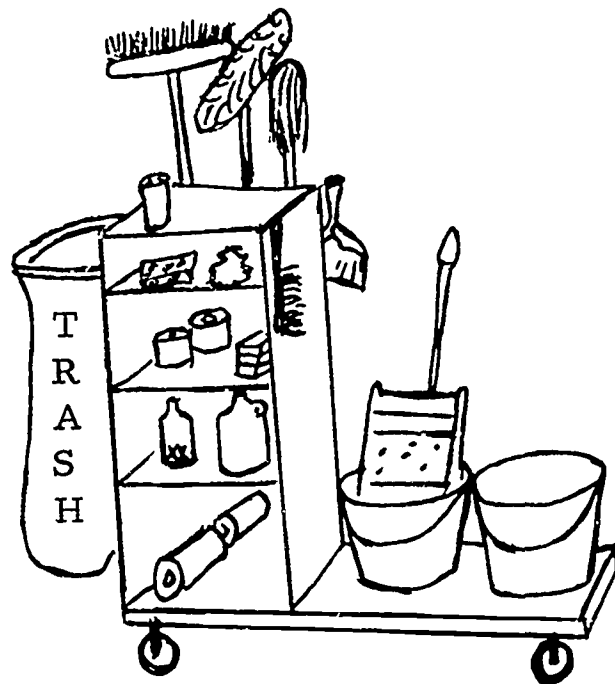

WASH BASIN CLEANING

1. Wash basin

Dampen sponge with detergent solution.

Wash the basin inside, outside, and underneath.

Be sure to wash piping under basin.

Use abrasive cleaner for stubborn stains and soil.

Do not use abrasive cleaner on chrome.

Do not use acid cleaner on sinks or wash basins at any time.

2. Rinse solution from basin

Rinse basin with a wet sponge or rag.

Wipe chrome with a paper towel or rag to polish.

Inspect for maintenance needs as it is being washed.

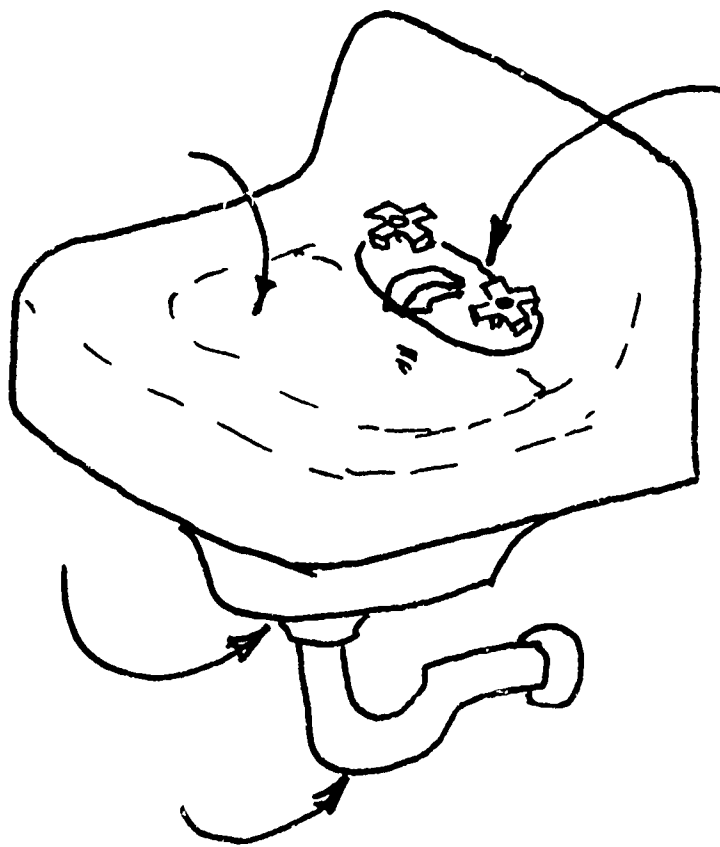

URINAL CLEANING

NOTE: Do not use acid-type cleaners on urinals.

1. Wash outer surface of urinal

Wear rubber gloves.

Use sponge and sanitizing detergent solution.

Wash all the urinal, including metal plumbing.

Use abrasive cleaners when necessary but not on chrome fittings.

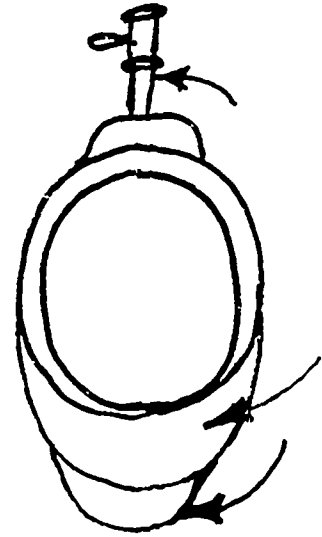

2. Wash inside of urinal

Wash inside of urinal with sponge and detergent.

Be sure to wash thoroughly the hidden surfaces of the rim.

Use a small mirror to check cleanliness of hidden surfaces.

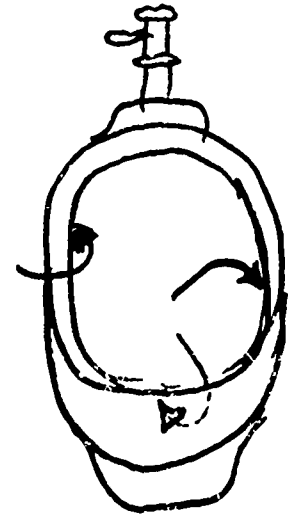

3. Flush urinal

4. Wipe exterior

Rinse cleaning solution from the exterior with a wet rag.

Wipe chrome with a dry rag or paper towel to polish.

5. Flush the urinal trap with a hose occasionally... where conditions permit.

6. Pour one cup of the detergent solution into the trap... leave overnight. This may be done occasionally to combat odor and soil buildup in the trap.

TOILET CLEANING

1. Flush toilet

Put on rubber gloves.

Look for stoppage, clogging, foreign objects, and maintenance needs.

Use plunger (plumber's friend) if needed.

2. Force excess water from bowl

Force as much of the water over the trap as possible. Use the bowl brush and a rapid downward pumping action. A plumber's friend may be used. This is done to reduce the diluting of the cleaner to be added next.

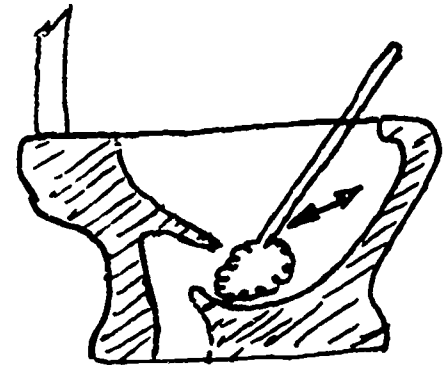

3a. Daily, clean inside of toilet bowl with sanitizing detergent solution.

Follow this step for daily cleaning when a thorough inspection reveals the acid cleaner is not needed. Excessive and unwarranted use of acids causes pitting and corrosion of fixtures and fittings. Acids are extremely harmful to cement, floor materials, and metals.

Scrub the inside of the bowl with detergent solution and a bowl brush or sponge. Scrub under the rim and into the trap.

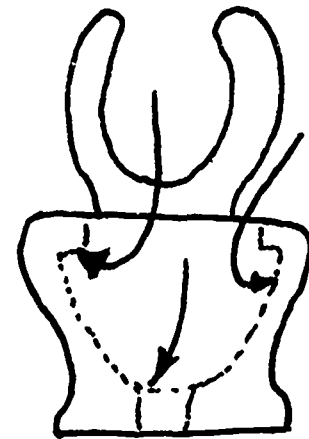

3b. Weekly, clean inside of toilet bowl with acid-type cleaner.

Spread the cleaner around the bowl under the rim. Scrub this area well with the brush.

Scrub the other surfaces inside the toilet bowl reaching into the trap as far as possible.

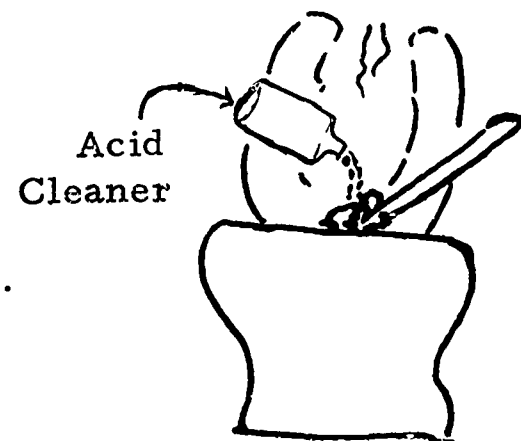

CAUTION: Don't allow the acid cleaner to get on anything outside the bowl area. In case of spills or splatters, wash immediately with water. The acid may be neutralized further with soda.

4. Flush the toilet

While flushing, wash acid cleaner from underside of rim.

Rinse the bowl brush while flushing.

5. Inspect under the rim with a mirror

A major source of odor is the hidden soil under the rim.

Repeat the acid cleaning if soil accumulation is found.

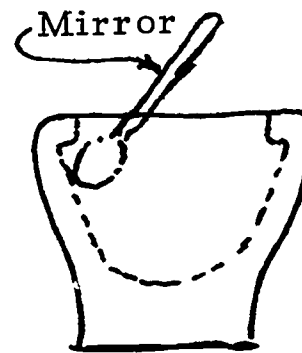

6. Wash the exterior of commode

Wash all the water closet exterior with sponge and sanitizing detergent solution. Wash seat, seat hinges, fittings, and water closet base. Pay particular attention to the underside of the seat.



7. Rinse and wipe exterior

Rinse the cleaning solution from the areas washed with a wet rag or sponge.

Wipe chrome parts with a paper towel or dry rag to polish.

CLEANING RESTROOM WALLS AND PARTITIONS

1. Clean walls and partitions

Wipe with damp sponge or rag. Use detergent solution as needed.

Be sure to wash away any urine that may be on partitions or walls.

Use a cleanser for removing stubborn soil or stains.

2. Clean horizontal surfaces

With a damp cloth, wipe dust from the top edges of partitions, tile nosing, window sills, dispensers, etc.

3. Spot cleaning

Remove finger prints, stains, and marks from doors, frames, and walls with a detergent solution and rinse. If necessary, use abrasive cleaner on a sponge.

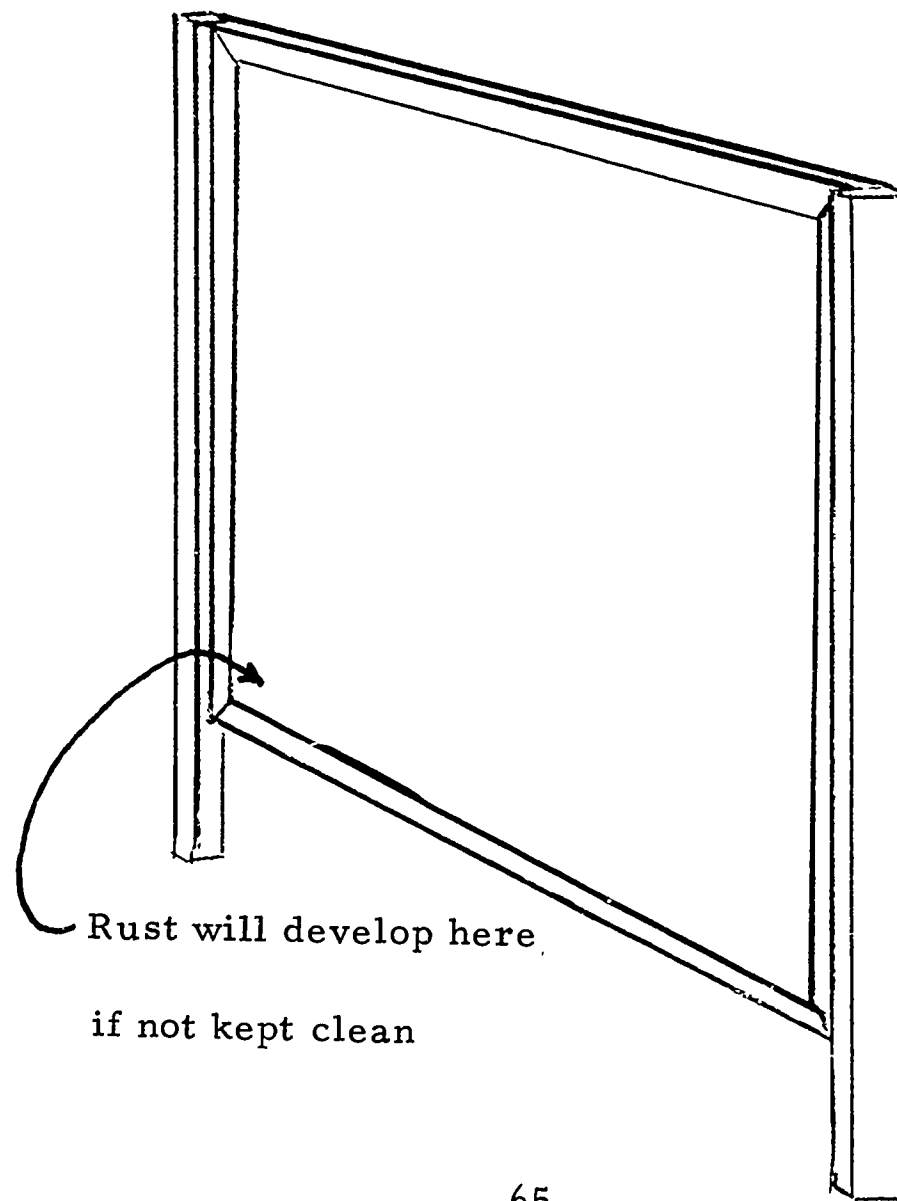

CLASSROOM CLEANING

If there is a secret to efficient room cleaning, it would be ---- BE SYSTEMATIC. Have the equipment and materials needed to do the job, have it organized to eliminate every unnecessary step and lost motion, and how to use it. An inexperienced (and sometimes even an experienced but uninformed) costodian may use as much as 40% of his time in needless and unproductive efforts to transport materials and equipment, looking for things, or trying to figure out what to do next.

Just walking around in circles can be hard work but accomplish nothing. One must be systematic and plan every routine task.

The following suggestions are aimed at helping the custodian develop systematic methods. Each school situation may require changes or modifications. It is recommended that the following procedures be tried and used until improvements are found.

MATERIALS NEEDED:

Maid's cart, containing the following items:

Dust mop, 16 to 24 inches, swivel head

Trash container, light weight, canvas, paper, plastic; may be of disposable type

Dust cloth, treated

Rags, wet

Rags, dry

Detergent solution (pre-mixed in plastic spray bottle)

Sponge

Floor brush

Dust pan

Erasers, for exchanging

Chamois, for chalkboards only

Chamois, for glass and mirrors

Counter brush

Radiator brush

Putty knife

Screwdriver, for preventative maintenance

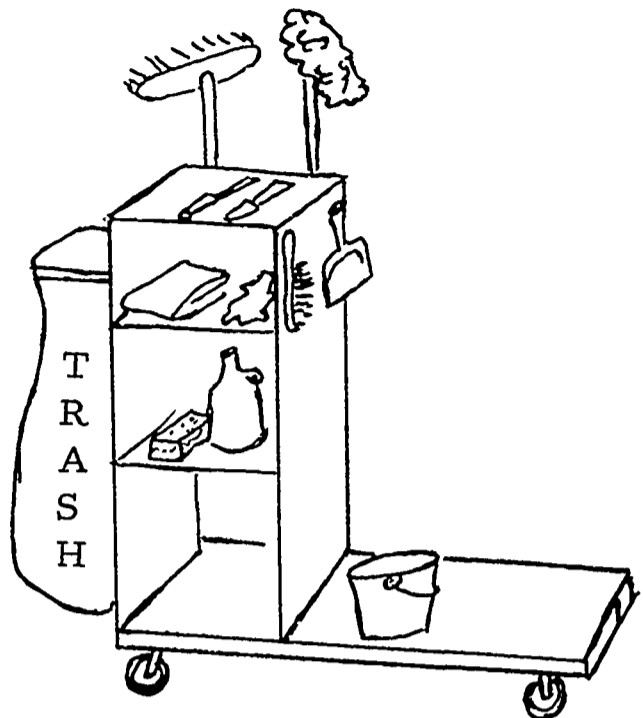

WHILE DOING REGULAR WORK, THE CUSTODIAN SHOULD ALWAYS BE WATCHFUL FOR MAINTENANCE NEEDS AND, ESPECIALLY, PREVENTATIVE MAINTENANCE OPPORTUNITIES. HE SHOULD KEEP A PUTTY KNIFE AND SCREWDRIVER IN HIS POCKET AT ALL TIMES AND OTHER TOOLS NEAR AT HAND.

DAILY PROCEDURE

1. Remove waste

Empty pencil sharpener.

Pick up larger pieces of paper and trash.

Empty wastebaskets into trash container in corridor.

NOTE: For every dirty condition, such as wood shop, it is best to brush off benches, sweep the floor with a floor brush, collect shavings and trash, and then clean another room while the dust settles.

2. Dusting

With a treated dust cloth, dust furniture, window sills, cabinets, desks, and other horizontal surfaces.

Dust high surfaces first, progressing to lower areas.

Put things back in their original place when necessary to move them to clean.

3. Spot clean

Spot wash finger prints and soil from doors, furniture, and the like with a damp sponge and detergent solution. Every custodian should have a small spray bottle of detergent and a sponge ready for spot cleaning.

4. Clean chalkboards

Don't leave this to teachers and students.

Wipe chalkboard with a dry chamois used only for chalkboards.

Wipe chalk tray with a damp sponge or rag.

Exchange clean erasers for dirty ones from one to five times a week, depending on their use.

5. Clean glass, sinks, etc.

Wipe or wash glass and mirrors as needed.

Damp wipe or scrub sinks as needed. (See Restroom Cleaning.)

6. Dust mop floor

Use a swivel-head dustmop, 16 to 24 inches.

Begin at the door, go around the edge of the room to the farthest corner.

Work under furniture pushing dirt into aisles without lifting the dust mop. Use a circular or figure eight motion. After cleaning under a row of desks, mop the aisle. Proceed from aisle to aisle, finishing at the door. When the dust mop becomes loaded, push it through the door to corridor, lift it a few inches, give it a sharp, quick shake. Frequent brushing with a stiff brush will increase dust pickup.

7. Close windows and adjust shades
8. Set temperature controls, if needed
9. Rearrange furniture that had to be moved
10. Do preventive maintenance tasks

Make minor repairs and adjustments which can be done with tools.

Make a note of needed maintenance jobs which require more time, tools, or materials, or which will need to be referred to the maintenance men. The custodian who simply tightens a screw while doing his cleaning will prevent much more time and cost later.

CLEANING CORRIDORS, STAIRS

The corridor by its very nature does not lend itself to a routine, once-a-day cleaning as do classrooms and other areas. Most of the dust and soil found in the rooms has been carried into the building through corridors. Any dirt captured in entrances and corridors will not have to be swept up later when it is much harder to reach. The following suggestions outline necessary steps and offer time-saving measures that can be of great help to the custodian.

1. Entrances

Place entrance mats at all entrances. They should be large enough to be functional and constructed so as to collect as much dirt as possible. A coarse fiber mat is very good, but any mat used must be cleaned often. The more often it needs to be cleaned and the more soil it contains, the more proof there is that mats are doing a good job.

2. Corridor floors

Corridor floors should be cleaned with a large (about 48 inch) treated dust mop at least three times a day; after school has opened each morning, after lunch, and after rooms have been cleaned in the evenings. Also, the corridor will need dust mopping after any large group of people enter the building. The custodian who neglects these tasks should realize that dust and dirt is never easier to remove from his building than when it is on the corridor floor.

3. Corridor accessories

Doors... Entrance doors, including glass, should be cleaned daily and may be cleaned while school is in session.

Windows... Windows need periodic cleaning and may be cleaned during the school day.

Lockers... Lockers in corridors may be cleaned during the school day, and many minor repairs they will need may also be done at this time.

4. Spot cleaning

Many corridor items and areas lend themselves to cleaning during the school day without interrupting classes. These include entrance mats, doors, glass areas, some windows, lockers, fountains, trash cans, light fixtures, walls and ceilings in some cases.

Trash cans should be the only movable item in corridors and should be near, but not in, the lines of traffic.

Drinking fountains should be damp wiped two or three times a day. It is very important to keep the bubbler properly adjusted.

Wet mopping and spot mopping is a frequent necessity. It should be done promptly, and the area should be left as dry as possible for the safety of children.

Preventative Maintenance

Many, many minor maintenance jobs can be done in a corridor during the school day. A good custodian is always on the lookout for little jobs that can prevent big problems.

CAFETERIA CLEANING

The care and cleaning of the kitchen and lunchroom areas require cooperative arrangements between the custodial and lunchroom personnel. The local school administration will need to outline these arrangements in light of the local situations so that good relations and efficient operation can be maintained.

Generally, the kitchen area should be the responsibility of the lunchroom personnel. The custodian will need to extend assistance in several ways. He should assume the responsibility for heating, lights and electrical items, water, sewage, and garbage removal.

Care of the lunch room area would, in most cases, be the responsibility of the custodial staff. During lunch periods, a custodian should be on hand to take care of spills and dispose of garbage and trash.

After lunch or after school, as the case may be, the custodian should clean the lunchroom in a systematic manner. He should:

1. Damp wipe tables and chairs

Stack chairs on tables if practical.

2. Mop floor

Wet mop or dust mop floor as needed.

3. Remove waste

Burn paper and trash.

Remove non-burnable trash and garbage from school grounds.

4. Wipe drinking fountains

5. Spot clean walls and doors as needed.

CLEANING THE AUDITORIUM

The auditorium area referred to in this topic is the traditional type area with inclined floor, fixed seats, and a stage. The multi-purpose type room is not identified specifically as an auditorium and is usually cleaned in the manner of any other area having movable furniture and comparable floors. Any area having fixed seats is a problem area for the custodian. This problem has increased as schools have found it necessary to use the auditorium for daily instructional space.

The methods and techniques for servicing the auditorium are not as well standardized as are methods for servicing other areas of the school plant. However, the following suggestions represent much experience and may be helpful to many custodians:

1. Keep appropriate floor mats at all auditorium entrances.
2. Keep curtains drawn open to reduce their dust collecting area.
3. Clean the floor area before dusting the seats. Tilt seats to up position.
4. Clean the floor of the seating area before cleaning side aisles.
5. Do not use strong cleaners or oily dust cloths on auditorium seats.
6. Sweep with small brooms or small dust mops.
7. Sweep from the back of the room toward the stage - not toward the side aisles.
8. A portable vacuum unit with a long hose may be used to an advantage.
9. Use only mild detergent for wet mopping as strong cleaners will cause rust.
10. Use clear sealer instead of paint on concrete floor of seating area.
11. Use only slip resistant wax on side aisles, and do not wax between the seats.

12. Faulty or broken seat parts should be replaced immediately upon discovery.

Safety considerations are of utmost importance in the auditorium. Do not allow chains on any exits while the building is occupied. Aisles and passageways must be free of obstruction at all times, and combustible material must not be allowed to accumulate about the stage area. Stage wiring and lighting must conform to all fire and safety regulations, and stage fire extinguishers must be kept functional.

WINDOW CLEANING

The windows are the "eyes of the plant" and transmit light and provide ventilation. Windows must receive the care that enables them to perform their function properly. Any light obstruction such as dust, soil, curtains or shades tend to compromise the function of the window. Window shades should not be installed on school windows until it has been established that they are essential for light control.

Window cleaning operations need to be scheduled for definite intervals if they are to be properly performed. More cleaning and dusting will be required for the inside of windows than the outside. Regular dusting with a dry cloth will reduce the amount of cleaning required on all inside glass surfaces.

The location and type of windows are large factors in determining the most satisfactory methods and materials to be used. Window cleaning can be a very hazardous operation if safety measures are neglected. Faulty equipment, slick shoes, leaking containers and rotted window sash are invitations to accidents.

Speed is essential if the school windows are to be kept in satisfactory appearance. The skill or "knack" of using a window squeegee will increase speed and ease of window washing.

In selecting the best cleaner for windows, it must be remembered that glass cannot absorb any soil, and, thus, the soil or dirt that one sees on windows is only on the surface. Most dust and dirt accumulations may be

removed with water, but the presence of some grease, oil, fumes, etc., in the air make it desirable to add a small amount of grease-cutting cleaner. One tablespoon of strong ammonia per gallon of warm water or one-half tablespoon of trisodium phosphate per gallon will make an efficient and very economical cleaner. Commercial window cleaners are available. Some contain alcohol to speed drying plus coloring and perfumes, among other ingredients. The question of economy is very important when buying commercial window cleaners. Do not use cleaners containing abrasives.

The equipment list needed for window washing is not lengthy. For outside washing at hard-to-reach windows, a hose and long-handled fountain brush is recommended. A commercial product is available for this purpose, and its cost will probably be recovered several times in labor savings. Most exterior windows may be washed best with a window brush squeegee equipped with a long handle or window pole. Ladders must be selected to meet each individual school situation.

WASHING WINDOWS--Inside

When washing glass within the school, the custodian needs to be more careful to avoid messy dripping. The dropcloth is a helpful precaution and should be used. If the dropcloth is not used, more care should be exercised. Water should be wiped from the window frame and sill and from the floor.

A chamois may be used equally well in place of a squeegee, but it may be a bit slower. When wiping glass with a chamois, it should be clean and squeezed as dry as possible. The custodian should work with a sponge in one hand and the chamois or squeegee in the other hand.

The most widely accepted equipment used for inside window cleaning is a spray bottle and clean rags.

WINDOW WASHING WITH SQUEEGEE AND SPONGE

1. Assemble equipment needed

Squeegee
Sponge
Bucket
Clean solution (about 2 tbs. ammonia
per gallon warm water)
Ladders, as needed
Dropcloth

2. Wash the glass

Dip sponge in solution and squeeze out.
Use only enough water to do the job.

Scrub entire window, loosening the dirt.
Wipe the edges of the sash.
Work with sponge in one hand and
squeegee in the other.

Change solution frequently.

3. Squeegee the window

"Cut the water" from top edge of glass
using edge of squeegee (See Fig. 1).
Stroke the window downward to the muntin.
Wipe squeegee and repeat until
finished. (See Fig. 2.)

Squeegee the lower edge of glass as
in Fig. 3.

Wipe lower edge at sash with near-dry
sponge.

An alternate method of using the squeegee
is given in Fig. 4.

Remember--Always wipe squeegee each
time it is taken from the glass.

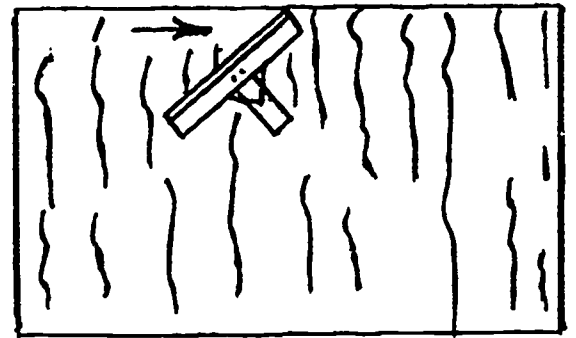

Fig. 1

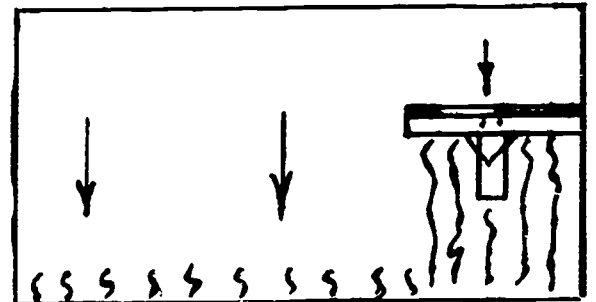

Fig. 2

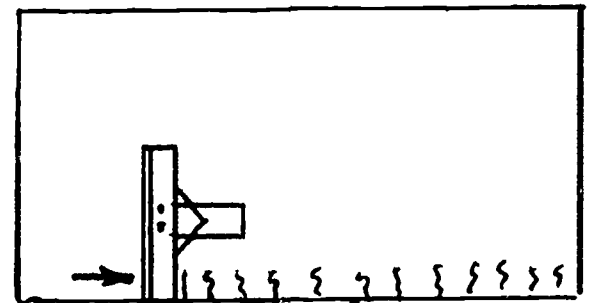

Fig. 3

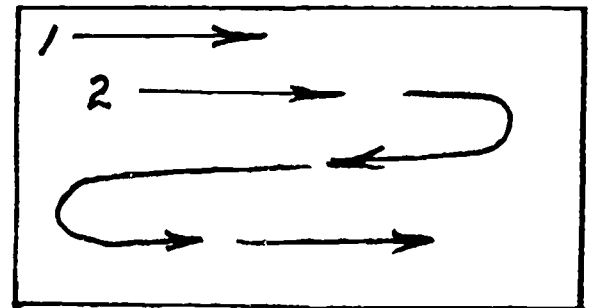
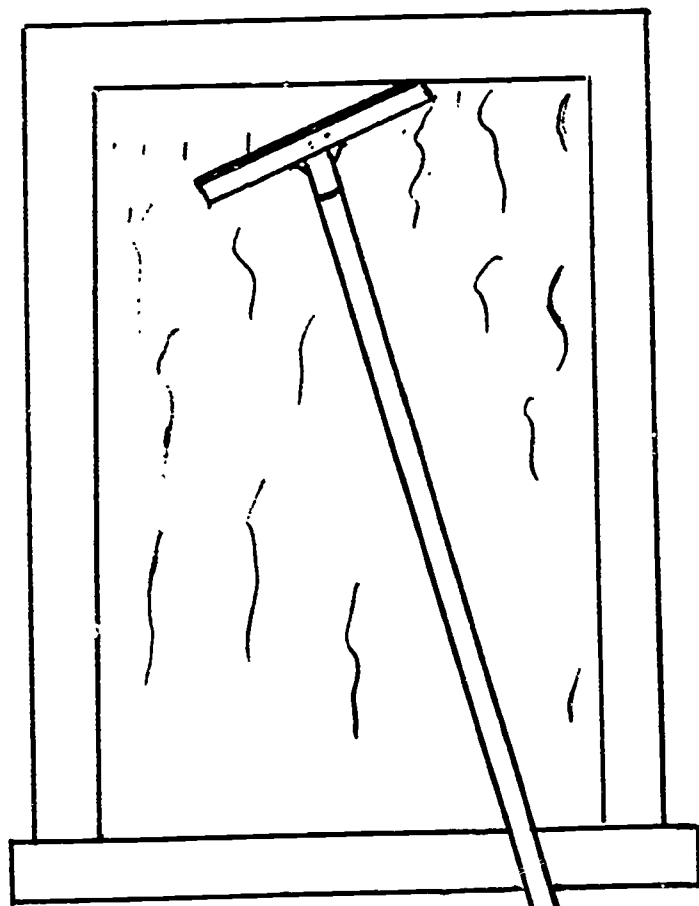
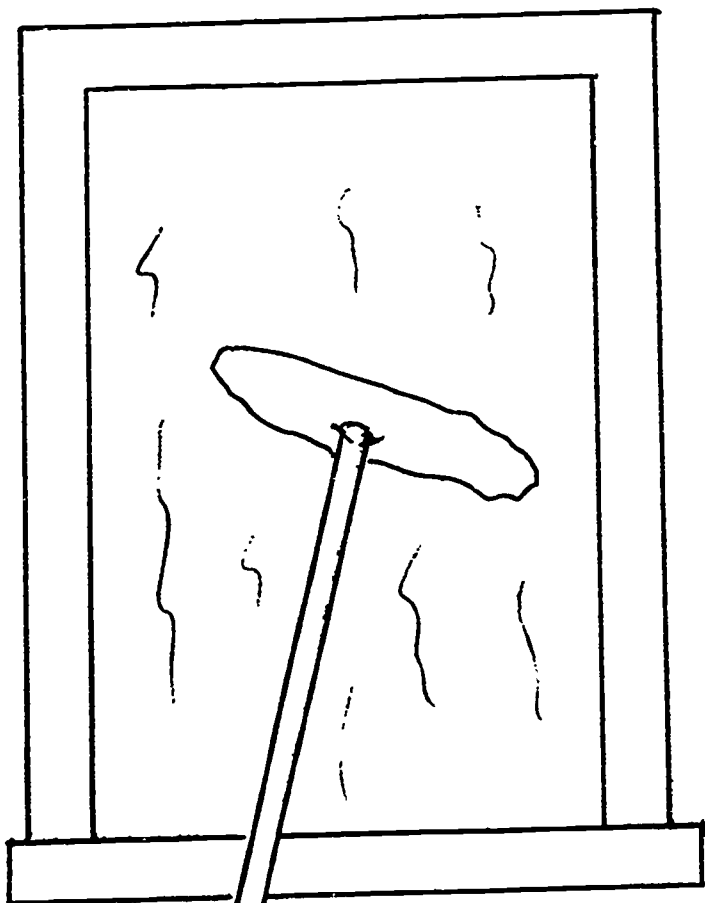

Fig. 4

WASHING WINDOWS--Outside

When working outside the building, the custodian need not be quite so careful with water dripping, but a greater problem usually arises in that the outside windows are usually higher. This makes the use of long-handled squeegees and brushes necessary. The use of long extension ladders is often needed.

For most schools two stories or less, the windows may be washed by standing in the window or by using long-handled tools, as in Figures 1 and 2. Safety precautions must be taken when standing in or outside windows. Proper shoes, ladders, safety belts, or similar safety devices are recommended.



WASHING HIGH WINDOWS

When windows cannot be reached without extension handles, the following procedure should be used:

1. Scrub window with a towel wrapped around a squeegee, or a brush suitable for window washing, or a sponge attached to a block and handle.
2. Squeegee the glass dry.

CEILING CLEANING

Methods and materials used when ceiling cleaning depend largely on the kind of material of which the ceiling is constructed. The frequency of ceiling cleaning will depend on several factors, including the heating fuel used, the type of heating system, the activity in the room, and prevailing humidity and weather conditions.

It is desirable that school ceilings that are washable be washed yearly and dusted once between washings. Those non-washable ceilings should be dusted or vacuumed twice yearly, but certainly not less than once each year.

In many cases, it is more economical to repaint a ceiling than to wash it. Dusting is necessary before painting to give a good bond without dirt streaks.

Dry Cleaning a Ceiling--Any Ceiling Material

This procedure may be used for cleaning any ceiling material and is the only safe method of cleaning some materials, such as acoustical tiles made of cellulose or very absorbent related materials.

MATERIALS NEEDED:

Vacuum cleaner with brush attachment, wand and extension

Art gum eraser

Wallpaper cleaner

Ladder

Scaffold, if available

1. Vacuum the ceiling

Start on one corner.

Take a strip or "land" about 4 feet wide.

Work the brush back and forth in one direction only.

Work with the grain of tile.

2. Remove spots

If vacuum does not remove some spots, try an art gum eraser or wallpaper cleaner.

Vacuum the spot to lessen the contrast with surrounding area.

Wash a Ceiling

This procedure may be used on washable acoustical tile and all other plaster or related materials.

MATERIALS NEEDED:

Ladders

Scaffolds

2 Sponges

2 Buckets

Detergent, general purpose

Art gum eraser

1. Vacuum the Ceiling

Clean the ceiling with the dry method to remove all loose soil.

See Dry Cleaning a Ceiling above.

2. Mix cleaning solution

Use a mild solution according to manufacturer's instructions.

3. Wash

Wash a small area with a semi-wet sponge and cleaning solution.

Do not use any more water than necessary on acoustical materials.

Cleaning solution should not be allowed to dry or soak into the ceiling before it can be rinsed off.

4. Rinse

Rinse the small area just washed.

5. Continue to wash and rinse

Proceed to wash and rinse a small area at a time.

The cleaning sponge may be held in one hand and the rinse sponge in the other.

Rinse sponges frequently.

Change rinse water frequently.

CAUTION: Be careful of water on ladder or scaffold or on the floor.

Arrange the setup so that moving ladders and climbing up and down is kept to a minimum.

WALL CLEANING

Dust gradually accumulates on walls and ceilings until some form of cleaning service is required. Wall dusting may improve the appearance or washing may be necessary. Some types of interior surfaces can be cleaned effectively, while others may better be repainted. Smooth walls such as tile, plaster, marble and wood can be washed effectively; but rough surfaces may better be painted. Some maintenance officials question the economy of extensive washing of any type of wall surfaces, as the labor cost approximates that of painting and the results are not as satisfactory or as durable. Painting walls with epoxy paints reduces washing time and cost greatly.

WALL DUSTING

A back-pack vacuum would be an excellent dusting tool when equipped with the proper attachments, or a wet/dry vacuum may be used when properly equipped. A long-handle wall dusting brush will serve the purpose well. Walls should be dusted from the top downward.

WALL WASHING

Walls will get soiled and they must be cleaned. Whether dusting is sufficient will depend on the local conditions and situations. Frequent dusting will postpone the need for washing or painting, but the need for washing will doubtlessly come. It is always nice to see a newly painted wall, but

perhaps too often much needed money is spent repainting when a good washing from time to time would keep the walls looking nice. Wall washing should be a planned part of the summer cleaning program.

No single cleaning method or materials can be identified as the best; however, satisfactory results may be obtained by the following procedures:

1. Prepare the room

Remove furniture.

Spread dropcloths.

Set up scaffolds or ladders.

Provide ventilation as needed to aid drying.

2. Mix cleaning solution

Mix a mild to medium strength solution of general purpose detergent according to manufacturer's instructions.

Prepare one bucket with one to two gallons of solution and another bucket with rinse water.

Use a sponge or turkish towel for washing and another for rinsing.

A scrub brush may be needed for stubborn soil.

3. Start washing

Squeeze excess solution from the washing sponge.

Begin at the bottom and work upward, using circular motion.

Do not allow cleaning solution to run down into a dry and uncleaned area or an area that has been cleaned and rinsed. To do so will cause streaking.

4. Rinse the area just washed

Squeeze excess water from sponge.

Rinse cleaning from the area.

Change rinse water frequently.

5. Repeat the above steps until wall is finished

6. Clean related items

While washing walls, it is best to wash woodwork, moldings, door trim, baseboards, chalkboard or tackboard molding, etc., at the same time in order to save time and labor.

CLEANING LIGHTING FIXTURES

It is quite important that proper lighting be provided in all school areas. The health of pupils is affected by classroom lighting conditions. It is important that proper lighting be installed, and it is equally important that the custodian keep this equipment maintained by replacements when needed and by keeping fixtures clean. Dirty lighting fixtures reduces the amount of usable light. The cleanliness and color of ceilings, walls, windows, and furniture has a great effect on lighting conditions.

Light fixtures should be dusted several times a year. A duster or dust cloth which is free from oily substances may be used. A vacuum cleaner would be much more efficient for dusting. Some type of portable vacuum that can be carried on the back would be a great labor saver.

At least once each year the lighting fixtures, bulbs, tubes, and the like should be washed. This probably would be done early in the summer cleaning program. Washing fixtures is a two-man operation. A drawing is included herein to illustrate how the equipment may be set up.

EQUIPMENT AND MATERIALS NEEDED:

- Ladder or scaffold
- General purpose detergent
- Washing tanks (2)
- Sponges
- Table or stand, with casters
- Rugs
- Washing brushes to suit situation
- Drop cloth
- Screwdriver (for preventative maintenance)

PROCEDURE

1. Turn the light OFF.

2. Set up equipment.
Spread drop cloth.
Mix cleaning solution.
Fill tanks one-third to one-half full

3. Remove fixture covers, tubes, bulbs, etc.

The man on the ladder will remove covers, bulbs, and the like and pass them to the man on the floor.

The man on the floor washes, rinses, and dries the parts.

4. Move to second fixture.

He passes them down to the floor man.

He washes the remaining fixture and wipes it dry.

He checks for repairs needed.

5. Continue the procedure

The washing and exchanging of parts is continued around the room. When the ladder man is back to the first fixture, he washes it and replaces the parts.

This procedure of exchanging parts saves time and many steps.

6. Clean up the floor and move to another room.

(Venetian blinds and other furnishings might be washed while this equipment is set up in the room.)

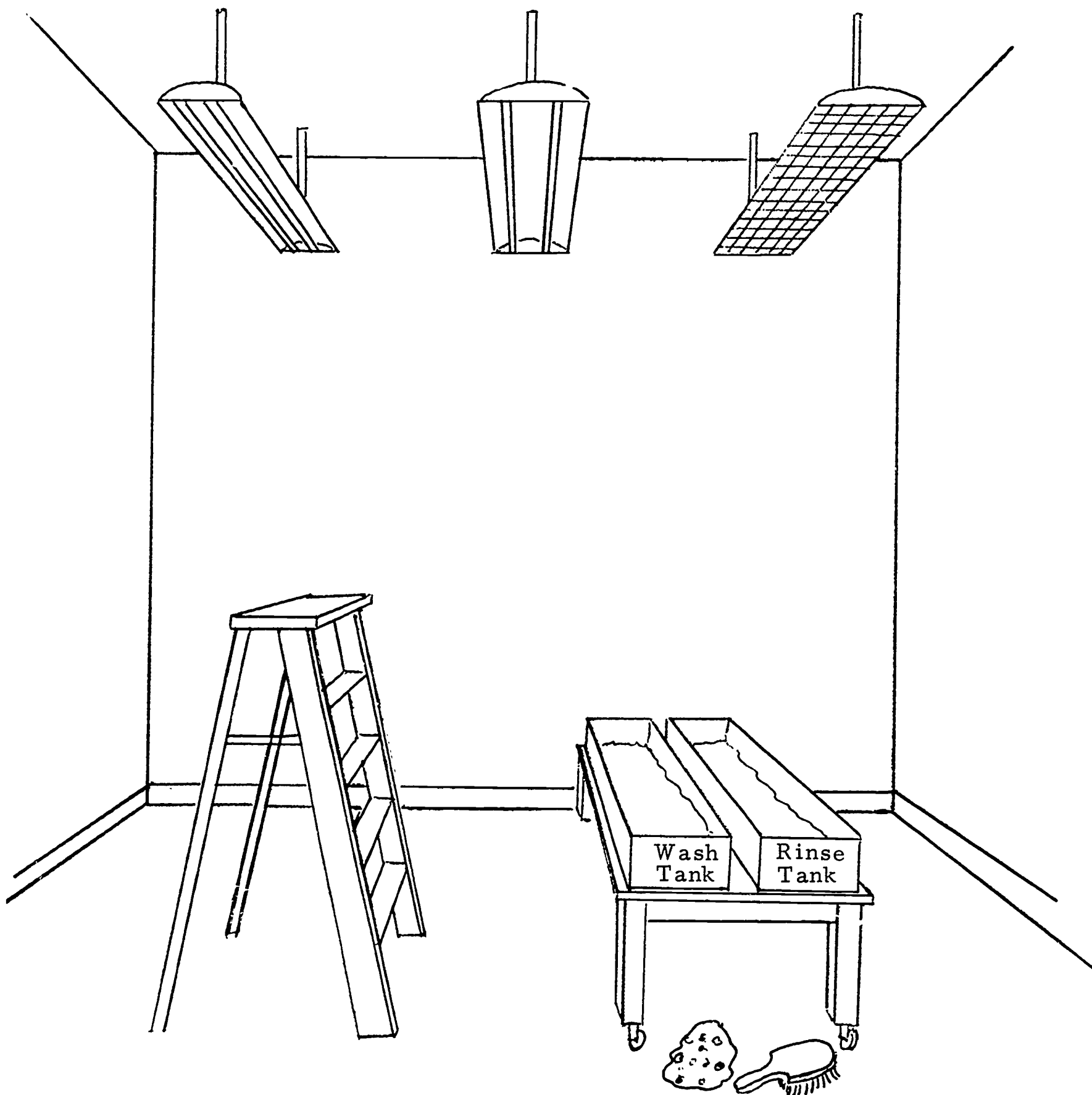

This is a two-man setup for washing electrical fixtures. A similar arrangement will work very well when washing venetian blinds and similar items.

In the above setup, one man will work on the ladder and one will work at the washing tanks. The ladder man will remove detachable parts and pass them down to be washed. He will then clean the remainder of the fixture, remove its parts, and exchange them for clean ones.

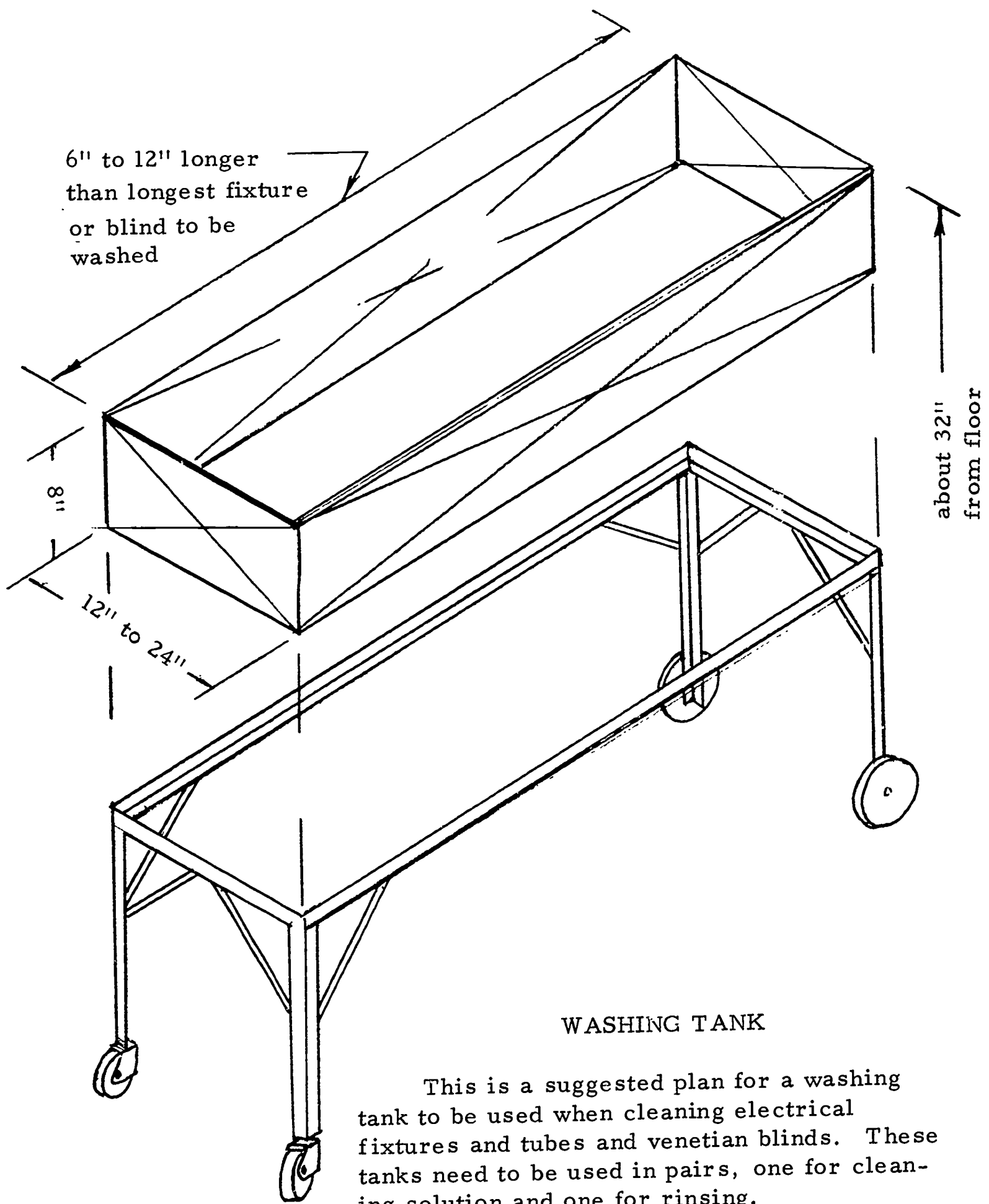

This is a suggested plan for a washing tank to be used when cleaning electrical fixtures and tubes and venetian blinds. These tanks need to be used in pairs, one for cleaning solution and one for rinsing.

CLEANING VENETIAN BLINDS

Venetian blinds should be dusted every three months, or as frequently as conditions dictate. A vacuum equipped with hose and long bristle tool may be used along with the dust cloth, duster, and dust mop.

When dusting, close the slats and dust all surfaces, then turn the slats in the opposite direction and repeat the dusting. Close the blind again and examine both sides for skips.

Venetian blinds should be washed yearly as part of the summer cleaning program if they are made of washable materials. Shrinkage may occur if cotton tapes are washed. The washing tanks and other equipment used when washing electrical fixtures may be used (see the section on washing electrical fixtures). Blinds and electrical fixtures can be washed at the same time while equipment is set up.

The blinds should be removed from the windows and washed with a sponge or brush in the washing tank with a mild detergent. They should be rinsed in the rinsing tank, wiped dry, and re-hung.

An alternate method of washing may be used when washing tanks are not available. Buckets may be used instead of tanks and washing and rinsing may be done with sponges.

Venetian blinds may be quickly washed if they can be spread out on a flat surface and washed with a brush and mild detergent. They may be rinsed with a hose and hung to dry. This, of course, requires that the blinds be taken from the room to a place when the use of hose is permitted.

When blinds are removed from rooms, they should be marked to insure their being returned to the correct windows.

CLEANING WINDOW SHADES

Window shades should be dusted every three months. Vacuum cleaning is the most expedient method. The shades should be spread out on a clean flat surface to be cleaned. If a vacuum cleaner is not available, a dusting brush may be used.

While cleaning, the shades should be examined for needed repairs. Many small repairs and preventative maintenance measures can be done while cleaning the shades.

Some shade materials may withstand damp wiping. Vinyl coated materials may be spread on a flat surface and cleaned with a damp sponge. The custodian must first determine if washing will not harm the shade material. If water is used to clean shades, they must be hung up to dry completely unrolled.

CLEANING FURNITURE

All school furniture should be washed each year as part of the summer cleaning schedule. Some furniture will require washing much more frequently, especially in areas such as art rooms, cafeterias, and elementary classrooms.

The cleaning solutions used on furniture should not be harsh. The dirt and grime must be removed but harsh materials may harm varnishes, lacquers, and plastics. Strong alkalies are very harmful to finishes.

Many, many small maintenance operations should be done while washing furniture. Loose screws, bolts, and fasteners should be tightened. Glides should be replaced when they become worn. Worn or defective glides can ruin a good floor finish very quickly. Dirty glides will mark up the floor quickly. Defective furniture that needs a cabinet-maker's attention should be sent to the maintenance department.

It is a common practice to store furniture in the corridor while the room is being cleaned and the floors rewaxed. The furniture could be washed in the corridor and then returned to the clean room.

MATERIALS AND EQUIPMENT NEEDED:

Buckets, 2

Sponges, 2

Detergent

Mop, wet

For Maintenance:

Hammer

Screwdriver

Nippers (for pulling glides)

Extra glides

Adjustable wrench

PROCEDURE

1. Set up equipment

Move furniture to an area where water will not harm the floor.

Mix a medium cleaning solution in one bucket.

Put rinse water in a second bucket.

2. Inspect and repair any defects

Go through a group of furniture checking for needed repairs. Check fasteners, glides, and joints. Change glides and joints. Change glides as needed. Make other minor repairs.

Send major repair work to the maintenance department.

Remove chewing gum with putty knife or a chisel-like tool.

3. Wash furniture

Washing a piece of furniture with a sponge and detergent.

Rinse before the cleaning solution can dry.

Wipe excess water from furniture.

Be sure to clean glides.

4. Return furniture to room

If the room has been completely cleaned, including the floor waxing, return the furniture.

Carry the furniture to prevent marking newly finished floors.

5. Move setup to next room.

CHALKBOARDS

It has been said that there is not a product made that someone could not make cheaper in quality and sell at a lower price. This is very true with chalkboards and accessories.

The wisdom of buying cheaper products without determining lasting qualities and upkeep cost is to be seriously questioned.

It is important to know what materials are used in chalkboard construction.

SLATE

Slate has been the traditional material with which all other chalkboard materials have been compared. Slate is a natural stone which is quarried, ground, and polished into sheets of about one-half inch thickness. Slate is rather dense compared with other stones, but it has a slightly porous surface necessary when writing with chalk. The important thing to remember when comparing slate boards with other chalkboards' materials is that slate is solid rather than coated. It, therefore, offers long life possibilities that no other material can provide.

COATED CHALKBOARDS

This group will include all chalkboards except solid slate. Several core materials are used, upon which is applied one or more of several different coatings. Some of the

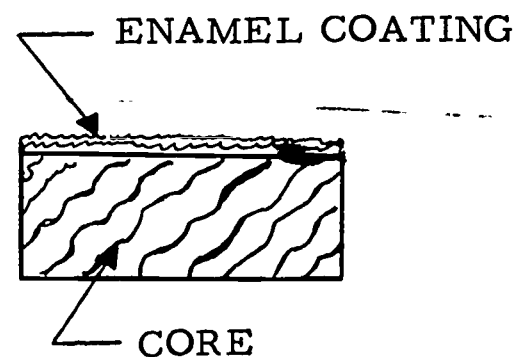

Figure 1

core and backing materials used are: glass, asbestos board, hardboard, paper steel, sheet steel on plywood, and sheet steel on hardboard.

All of these materials require a coating of some type in order to provide a good writing surface. The coating materials include porcelain enamel, vitreous enamel, baked and air-dried enamels. All of these contain abrasives or some provision to give a slightly rough or porous surface.

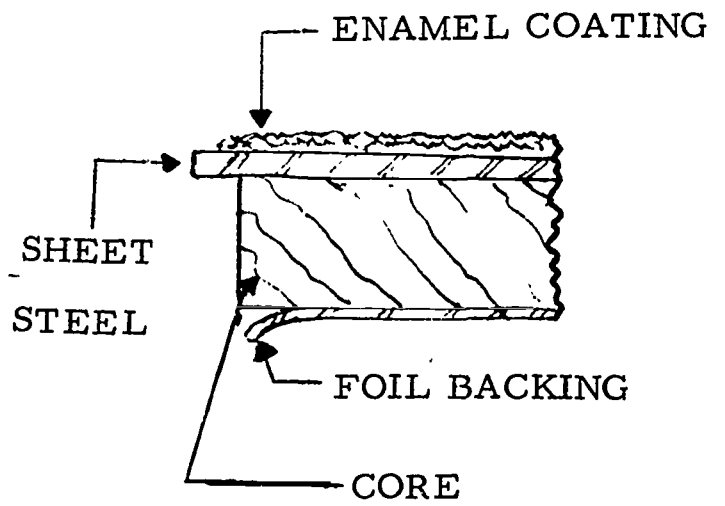

Figure 2

ERASERS

The erasers used on chalkboards are important to the life and usefulness of the board. There are several materials used in eraser manufacture.

FELT

The traditional and probably the best eraser material is felt. Only good quality erasers should be purchased. They should be constructed of several layers of good felt, well sewn together and attached to a good durable back. Erasers should not be washed or abused by beating but should be cleaned with a vacuum eraser cleaner.

LEATHER COMBINATION LEATHER AND RUBBER

These latter two types of erasers are said to clean with the aid of static electricity which attracts the dust. They may be cleaned with a cloth, chamois, or with a vacuum eraser cleaner.

CHALK

The chalk used is very important to the care of chalkboards. Saving a few cents in chalk cost or quality may cost dollars in maintenance and replacement cost of chalkboards. Good chalk should contain 95 per cent whiting, calcium carbonate, and a small percentage of binder or glue. The binder, or glue, is the cause of many chalkboard troubles. Any binder that becomes wet tends to fill the pores and seal the surface. This results in glazing of the chalkboard surface.

CLEANING CHALKBOARDS

Much confusion exists among our school people as to the best methods of caring for chalkboards. The preceding information and the following procedures have been found by experience to be the best methods of caring for all chalkboards.

BREAKING IN A NEW CHALKBOARD

1. With the side of a piece of top quality chalk, chalk the entire writing surface.

2. Erase the board with a clean, good quality eraser.
3. Repeat Steps 1 and 2.
4. Clean the board with a clean, dry chamois. Soft cotton may be used. Don't wash the chamois; just shake it well.

DAILY CLEANING

1. Simply erase the board at the end of each day with a clean felt eraser.
2. Clean the erasers as needed with a vacuum eraser cleaner.
3. Clean the chalk tray.

VACUUM
ATTACHMENT

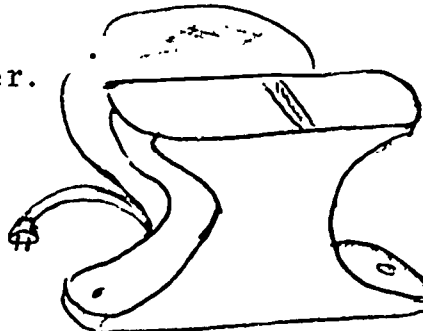

Figure 3

DRY CLEANING - Weekly Cleaning

About once a week or more often, the chalkboards will need to be dry cleaned.

1. Erase the chalkboard with a clean eraser.
2. Wipe the chalkboard with a clean dry chamois. The chamois should be used only for chalkboard cleaning.



ERASER
CLEANER

Figure 4

NOTE: The cleaned surface will have a slightly chalky appearance. This is as it should be.

Figure 5



An edge view of a new properly cleaned chalkboard as might be viewed under a microscope figure. It illustrates the porous or

rough surface. The open pores will hold the chalk and, thus, provide a good writing surface.

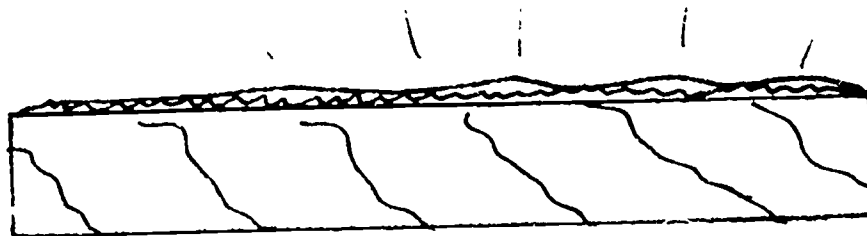

Figure 6

Figure 6 illustrates an edge view of an improperly used and improperly cleaned chalkboard showing how the pores of the rough surface have become clogged with chalk binder and dirt. This surface will not be a good writing surface. It may appear glazed or greasy. The chalk may skip or mark poorly.

SCOURING A CHALKBOARD--Slate

The makers of some slate boards suggest that an occasional scouring (annually, if needed) is permissible. Bon Ami or a powder cleaner may be used. Rinse well and remove the water with a window squeegee. Wipe dry with a chamois or cloth. Chalkboards should not be used until thoroughly dry.

CHALKBOARD CLEANERS

The use of prepared chalkboard cleaners is not recommended. The dry cleaning method is recommended. Oil, grease, wax, soap, and similar materials should never be put on a chalkboard.

TACKBOARDS

Today's better quality tackboards are valuable visual aids to instruction. Fortunately, they require less work from the custodian than chalkboards, but they do get dirty and need cleaning.

Better tackboards are being made of cork, composition cork, vinyl impregnated cork, rubber impregnated cork, vinyl covered cork, vinyl cloth covering over fiberboard, and similar materials. Most of these may be washed with general purpose detergents. Vinyl is washable and scrubbable. The higher the vinyl or rubber content, the more washable the surface. Powder cleaners should be avoided because of the dusty residue which remains.

WASHING TACKBOARDS

The washability of tackboard depends upon the material of which it is made. Cheaper materials will not withstand frequent scrubbing. It is best to test wash a scrap piece or a small inconspicuous area. Pure cork or nearly pure cork boards will absorb liquids more readily than vinyl or rubber impregnated boards and, therefore, are not as easily washed.

1. Scrub with a mild solution of general purpose detergent.
2. Use a sponge, rag, or scrub brush, if needed.
3. Rinse.
4. Wipe dry.

SANDING CORKBOARD

In some cases, it has been found possible to clean or reclaim a tackboard surface by sanding lightly with 5/0 sandpaper. This works best on high cork content materials. Sanding will not work satisfactorily on the tougher vinyl or rubber materials.

1. Test a small area

Wrap the sandpaper around a wood block to maintain a true surface.

Experiment on a small scrap or nearly hidden area.

If the sanding does not produce a dust or if it feels stick and tough to sand, or if the sandpaper clogs with a gummy or stick material, it is probably not advisable to attempt further sanding. In this case, resort to washing.

2. Sand all the surface

Avoid scratching the wood or aluminum trim.

3. Vacuum or brush the surface clean.

CLEANING THE BUILDING EXTERIOR

Fortunately, the exterior of buildings rarely need cleaning as often as other areas. Sandblasting is the most thorough method of cleaning masonry walls and must be done by a contractor as most school maintenance departments are not equipped for this work. This means of cleaning is thorough but harsh and can be harmful to softer mortars, marble, and limestone. Other wall materials, such as painted siding, may be washed with the same materials used on interior wood work.

Washing exterior walls is an often overlooked means of up-grading the appearance of schools. The thought of washing such vast areas requires consideration of all aspects of the problem. With newer materials and equipment, this is not an insurmountable task.

The appearance of newer masonry buildings that are exposed to sooty or dusty conditions may be kept presentable by washing with a general purpose cleaner and water. The walls should be wet with a hose before applying any cleaning solution. This is done to prevent streaking. The cleaning solution may be applied with long-handle brushes or sprayers. The rinsing may be done with a hose.

Since the cleaning of each building must be considered individually, no procedure can be outlined which will apply to all cases and conditions. The methods and materials chosen must be determined in light of each situation.

Some Exterior Areas Present Periodic Cleaning Problems:

1. Walks and entrances should be cleaned daily.
2. Entrance glass should be cleaned daily, as needed - - See Cleaning Windows.
3. Windows should be washed twice yearly, or more often, as conditions demand. See Cleaning Windows.
4. Entrance doors and trim, railings, and hardware should be kept clean by daily attention. Neutral detergent and water will satisfactorily clean most metal or painted surfaces. Use abrasive cleaners cautiously, and always rinse cleaners and chemicals from all surfaces after cleaning. Avoid using steel wool on marble and limestone, as rust stains result.
5. Vandalism and defacing of masonry walls too often confront the custodian. Smears, splatters, or printing on porous masonry with enamels, paint stains, grease markers are made more difficult by the variety of materials involved. To remove such materials requires promptness, knowledge of the defacing material, and the wall material itself. There is no magical answer to the problem. A suggested procedure would be:
 - a. Determine, if possible, the kind of material to be removed.
 - b. If not thoroughly dry, try washing with a solvent, such as turpentine, mineral spirits, alcohol, etc.
 - c. If the defacing has dried and the solvent normally used will not remove or soften it, try lacquer thinner, paint remover, or an alkali or caustic material cautiously. Wash thoroughly and rinse well after cleaning. It may be that an abrasive or scraping tool would be more practical. Testing the process on a small area is most advisable. See REMOVING STAINS FROM MASONRY.

SUMMER CLEANING PROGRAM

A properly cleaned school demands that the custodial program operate through the summer months. Many cleaning tasks cannot be done while the building is occupied without much delay and added expense.

Good planning for the summer work will insure more work and better production quality. It is recommended that custodians be scheduled to work in pairs. This reduces lost motion and permits equipment to be used more steadily. There are several tasks, such as floor finishing and electrical fixture washing, that work best with two custodians working together.

Prior to the beginning of the summer work, all building repairs should have been planned. Some work, such as boiler room maintenance and cleaning, can be done during school months. The custodian needs to know when various repairs are to be done. It is very discouraging to have clean rooms disturbed by maintenance work. By careful planning, the rooms and areas where maintenance men will be working may be by-passed in the summer cleaning schedule until repairs have been completed.

After classrooms are completed, other areas, such as gym, dressing rooms, library, cafeteria, etc., are cleaned. Then the corridors are cleaned. The central corridors would probably be the last area cleaned.

The summer cleaning of schools should begin with the classrooms on upper floors which are most remote from the center of activities and less likely to be disturbed after cleaning. The work should progress from room to room

toward the center of the school.

Several classrooms may be in the process of cleaning at the same time. This will reduce lost time and allow a resemblance of assembly line methods. With good planning, several custodians may be working on sequential operations at the same time.

1. Remove all furniture from the classroom.

Remove pictures, books, shades, posters, and other accessories from the room. It is common practice to stack furniture in the corridors while cleaning the rooms.

2. Do any repair work or painting that is to be done in the room.
3. Clean the ceiling. Wash if the ceiling material is of a washable material. Dust the ceiling if it is non-washable.
4. Wash the walls, woodwork, door and window trim.
5. Wash electrical fixtures.
6. Wash venetian blinds.
7. Wash windows.
8. Clean chalkboards and tackboards.
9. Strip and refinish the floor.
10. Wash the furniture in the corridor.
11. Return the cleaned furniture to the room. Wax or polish as needed.
12. Clean shades and other accessories and return to the room.

INSPECTING THE SCHOOL PLANT FOR MAINTENANCE NEEDS

Inspecting the entire school plant to determine needed maintenance is a prime duty of the custodian. This is not to say that an alert school administration is excused from making maintenance surveys as a matter of good business practice. The custodian, however, is near to the situation. He is in position to see maintenance needs first. Most all needed repairs increase in cost and difficulty with delay. Therefore, the quicker the problem is discovered and the quicker the correction is made, the better for all.

When reminded of the opportunities to help in preventative maintenance work, custodians often reply with the question: "Why should I be concerned with maintenance work when I have so much to do already and, besides, I don't know how to do those big, complicated jobs."

In reply to this, there are several fundamental facts which should be brought to mind. No one is in a better position to detect maintenance needs than the alert custodian who cares. He is not expected to do complicated jobs beyond his time or ability, but he can call these needs to the attention of his principal or the maintenance department by informing them, in writing, of the situation. Most all the large repair jobs which arise began at some time as small problems requiring simple talents and a minimum of tools and materials. In this area, the custodian can be a great help. If it is in keeping with local policy, he can make many minor repairs and adjustments which might otherwise progress into big and ex-

pensive repairs. A loose door closer screw can quickly become a broken door; and a loose roof shingle in November can become a leaky roof, a ruined ceiling, and a streaked wall in May. The efficient custodian will inspect his plant and grounds frequently. He will do many small preventative maintenance jobs, and he will request help as it is needed.

To illustrate how he can be very helpful in promoting good maintenance programs, the custodian should inspect the building exterior very carefully every few weeks, even though he is around the building every morning policing the grounds and checking for broken windows and the like. As he inspects his plant, he should make a list of things he can do and another list of things which require maintenance men.

As examples of what to look for when inspecting, the attic area, exterior walls, roof, and foundation areas are discussed below.

ATTIC

Check the attic areas a couple of times a year. Look for roof leaks or seepage. Check for rotting wood or water damage. Look for fire hazards and examine the chimney and vent pipes. Throw out any trash and junk that may be creating a fire hazard.

ROOF

The roof should be carefully inspected twice yearly, in the early spring and in the fall. Do not go on a roof during cool weather, as much harm can be done by walking on a cold roof. Remove any trash, such as leaves, that

may be found. Check gutters for stoppage. Look for possible leaks around all vents and other items that are found on the roof.

EXTERIOR WALLS

Examine the exterior woodwork for insect damage, loose nails, rotting, warping, and paint failure. Paint failure, for example, often indicates roof leaks or water problems.

FOUNDATION AREAS

The foundation and related parts of a building are often hidden and inconspicuous and are usually overlooked by maintenance men until something happens, unless some conscientious person is fully aware of these parts of a building and the seriousness of any failure of them. Poor drainage is the cause of most troubles in this part of a building. The custodian should look for settling around his building. He should check for cracking, movement, loose bricks or stones, mortar failure, and damage from trees. Drainage problems arise from broken tile, clogged area ways, plant damage, and earth settling.

WINDOW REPAIRS

Each morning the plant operator should try to walk around the building, policing the area and inspecting the building. This will too often reveal some broken windows. The plant operator should have on hand the tools and materials to make window repairs. He should have:

Ladders

Putty Knife

Putty or glazing compound

Glass, of sizes and types found in the building

Glazier points or wire clips

Glass Cutter

Wood Chisel

Workbench with a carpet or rug cover

Framing square or T-Square

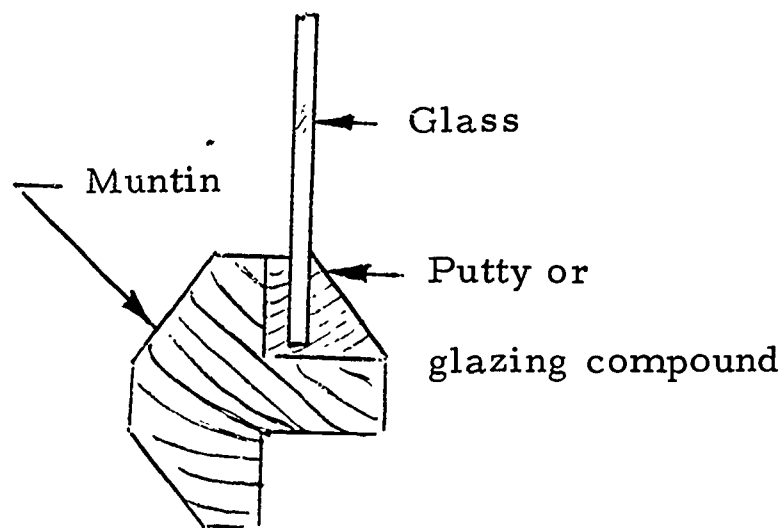

Some of the following suggestions may be helpful in cutting glass and replacing a pane:

1. Remove broken pieces of glass without damaging the muntins.
2. When bare wood is exposed, it should be painted before reglazing if possible.
3. Bed the glass with a thin layer of putty.
4. Install glass and secure it with glazier points or clips.
5. Glaze the window with putty or compound. The putty should be even with the inside edge of the muntin.
6. Paint the repaired area after the putty has begun to set.

CUTTING GLASS

1. An old carpet or rug scrap on a workbench or table makes a good work surface.
2. Use a T-square or framing square for a straight edge.
3. Cut glass about 1/8 inch less than opening measurements.
4. Dip glass cutter in turpentine to aid as a lubricant.
5. Apply even pressure, but not excessive, as you score the glass.
6. After scoring, break glass by snapping it briskly downward on the edge of the bench. For medium narrow pieces, apply a twist with the fingers. Very narrow scraps will need to be removed with the aid of the notches in the glass cutter.

Practice helps make perfect.

CUSTODIAL EQUIPMENT AND MATERIAL STORAGE

All custodial equipment should be stored in a systematic manner. Planned storage can extend the life and usefulness of equipment and greatly reduce the work load on the custodian. Many needless trips to storerooms looking for an item can use up more time than doing the job.

Store rooms should have adequate shelves for small tools and materials. Tool racks and tool panels should be provided for tools and accessories. All materials should be properly labeled for identification. A cabinet with a lock should be provided for harmful materials, such as acids and inflammables. There should be a place for everything, and every thing should be in its place.

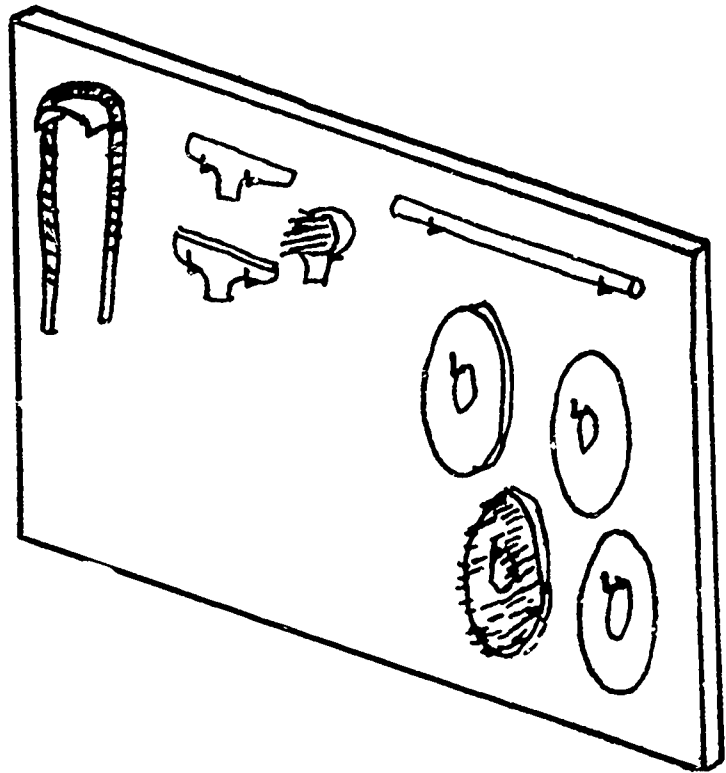
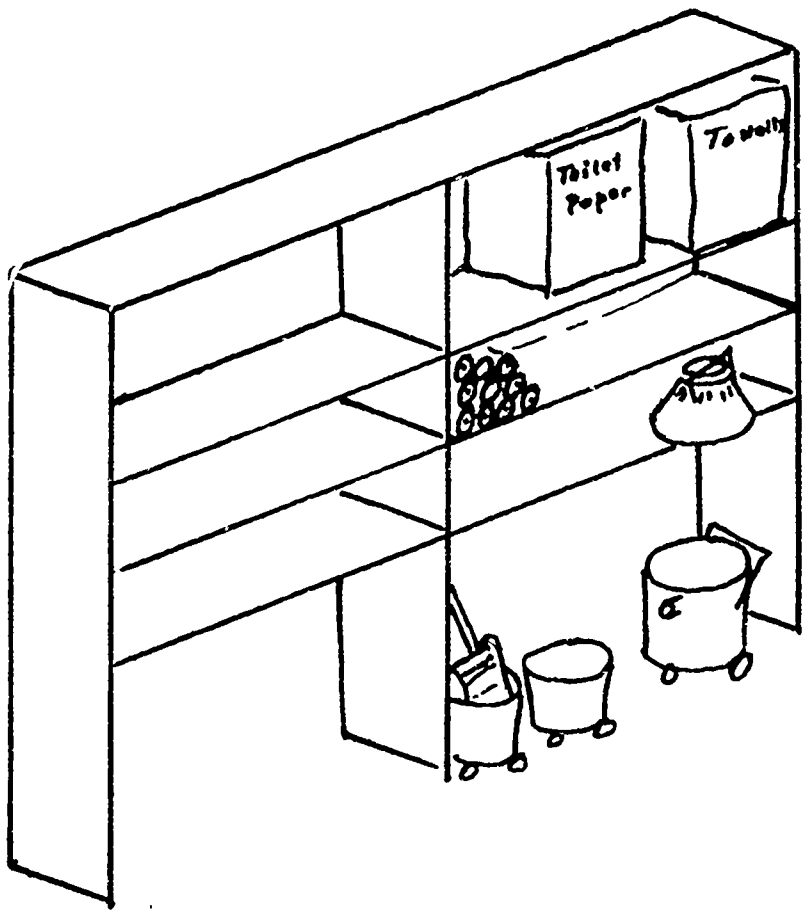

An inventory should be kept of all tools and equipment. This can be very helpful in preventing items from being lost. Custodians who are plagued with tools being lost or stolen can improve the situation by marking tools, keeping an inventory, and by having a specific place to store each item.

Lending tools can become a habit, and a bad habit for the custodian. He should discourage borrowers when he can do so without creating ill will.

Custodians could learn much from merchants about rotating stock. Far too often supplies are stored in such a careless manner that older items are not used before newer orders are opened. This often leads to spoilage and inferior quality due to aging. When a new order or shipment of things, such as cleaners, paper goods, soaps and chemicals is received, it should be stored behind older items already in stock. Marking shipments with the date received is a wise method of preventing aging of stock.

The storage of small items demands plenty of shelf space. Far too often, many materials are wasted as a result of improper storage which would far exceed the cost of shelving. Adequate shelving pays for itself quickly in labor and material savings. Quite a lot of shelving boards can be had for a few dollars and a small amount of time.

Floor Machine

Should be stored clean and dry, wire should be coiled, but not tightly, on the handle. Brushes, pads, and other floor machine accessories should be cleaned and hung up or shelved. Never leave brushes or pads under a floor machine.

Wet/Dry Vacuum

Should be clean and dry, tank should be uncovered, motor should be shelved, wire loosely coiled around the motor unit, hose should be loosely coiled on a shelf or hung in a manner that will not deform it. Other parts and accessories should hang on a tool panel. Before storing a wet vacuum, the motor unit should run about three minutes to remove any moisture that might be present.

Vacuum, Upright

Should be clean, bags empty, wire loosely coiled and accessories should be hung up or put in their respective place.

Lawn Mower

Lawn mowers and other gasoline powered equipment should not be stored in a school. They should be kept in a separate building or at the maintenance department. Gasoline or gasoline powered equipment should not be stored in boiler rooms or places where there would be flames or sparks to ignite fumes. Many schools have small buildings apart from the school in which they store equipment and flammable liquids. These buildings must be kept locked and no children may be permitted in them.

Mop Buckets

Mop buckets should be rinsed and wiped dry. Rust and corrosion forms when a little water or chemicals are left in buckets. Identify buckets as to use, such as waxing, rinsing, and scrubbing.

Wringers

Rinse after use, remove mop strings and store on buckets.

Toilet Bowl Brush

The brush should be rinsed after use and stored so that it will not come in contact with anything or anyone. Remember, the bowl cleaner used most likely contained hydrochloric acid. Acid or acid fumes will burn flesh, rust and corrode metals and harm many other materials.

Wet Mops

Mops should be marked as to their use: rinse, scrub, wax, and emergencies. Mops should always be rinsed after use, wrung dry, shaken to fluff the head and hung in their places. Wet mops may be hung head up or head down, but definitely hung up.

Dust Mops

Dust mops should be shaken and fluffed, but not hit against hard objects, and hung up. Mop heads should be changed, laundered, and retreated once a week, more or less. Mop heads should be lightly sprayed with a non-oily mop treatment and stored at least 24 hours in a tight metal container prior to use.

Corn Brooms

The brooms should be hung up with the straws down. Turning the broom frequently while in use will prevent deforming. Soak the tip of a new broom in water overnight prior to its first use.

Floor Brushes

The brushes should be hung up with bristles down. Wet brushes and brooms should be hung so that bristles will dry straight.

Rags, Wet

Wet rags should be rinsed and spread to dry in a well ventilated area. Don't hang wet rags on or over other equipment.

Rags, Oily

Oily rags should be burned or laundered immediately or stored in tight metal containers.

Chamois, Chalkboard

The chamois should be well shaken rather than washed, stored so that it will not come in contact with oils, soaps, water, dirt, or related matter. Keep away from heat.

Chamois, Window

The chamois should be washed and rinsed after use and hung up to dry.

Squeegees

The squeegees should be wiped clean and hung up so that rubber will not touch anything.

Sponges

Sponges should be rinsed after use and hung up or placed to dry.

Salt or De-icer

Salts used to melt ice and snow is very harmful to metals and other materials, including flooring. Keep it away from tools and equipment. The harmful effects can be reduced by storing in tightly sealed plastic bags which are, in turn, placed in cans or boxes.

Hose

Store hose on shelves or by hanging on a hose rack which will not cause the hose to kink. Nails and pegs are harmful to most hose materials. Do not permit oils or chemicals to remain in contact with hose.

Paper Goods

Store towels, toilet tissue, and other paper goods in a dry place. Since paper goods are usually light in weight, the higher storage shelves are often used.

Flammable Liquids

Paints, thinners, gasoline, alcohol, kerosene, and similar flammable material should be stored in some place other than the school if possible. Such liquids that necessarily must be in the school should be in metal safety cans. These cans should be on the upper shelves of metal cabinets or storerooms which are kept locked.

Ladders

Ladders should not be stored within reach of children. Ladders should be stored in storerooms where possible. Extension ladders should be hung up on hangers or pegs.

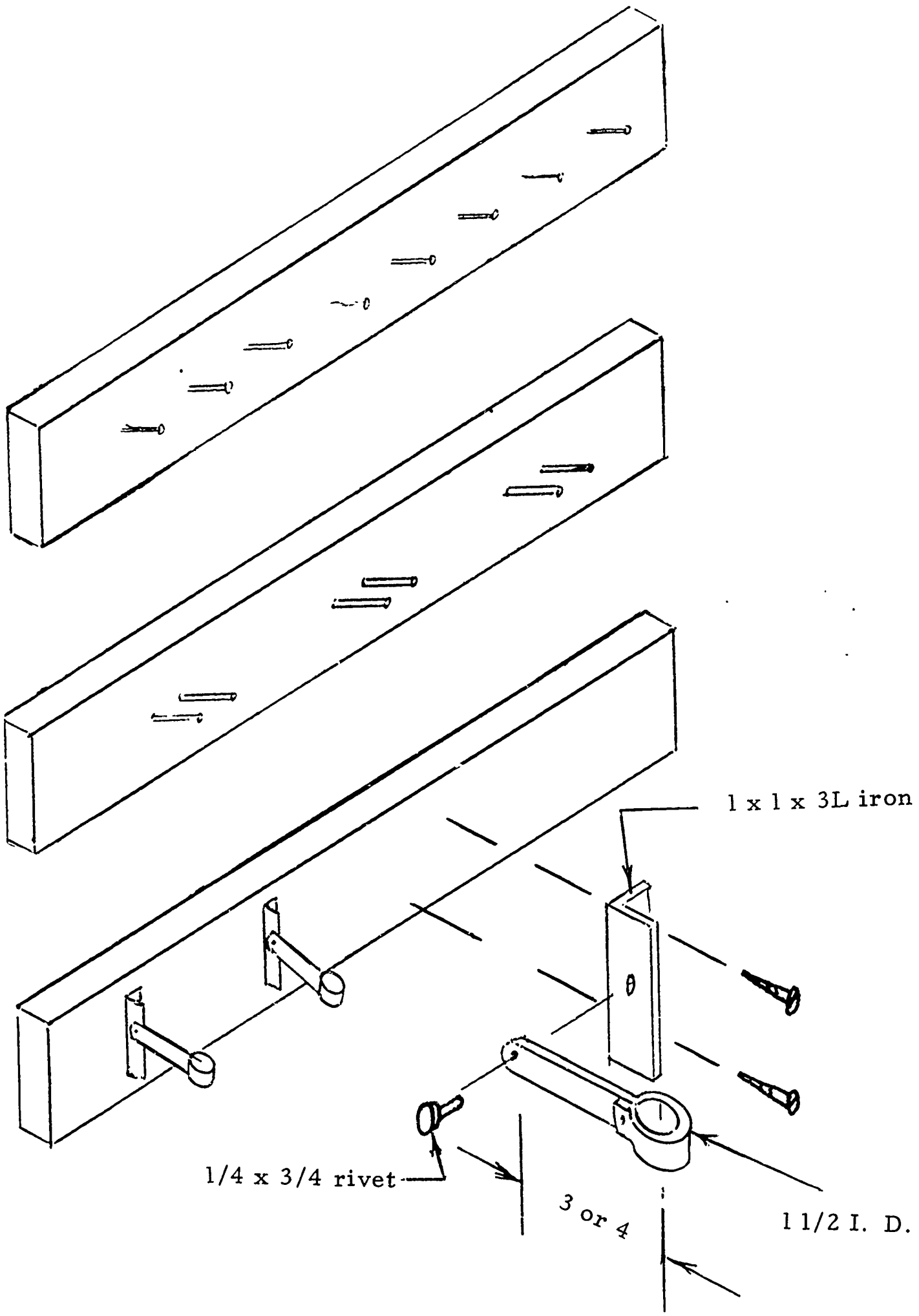

Suggested plants for
 BROOM AND MOP RACKS



WANTED

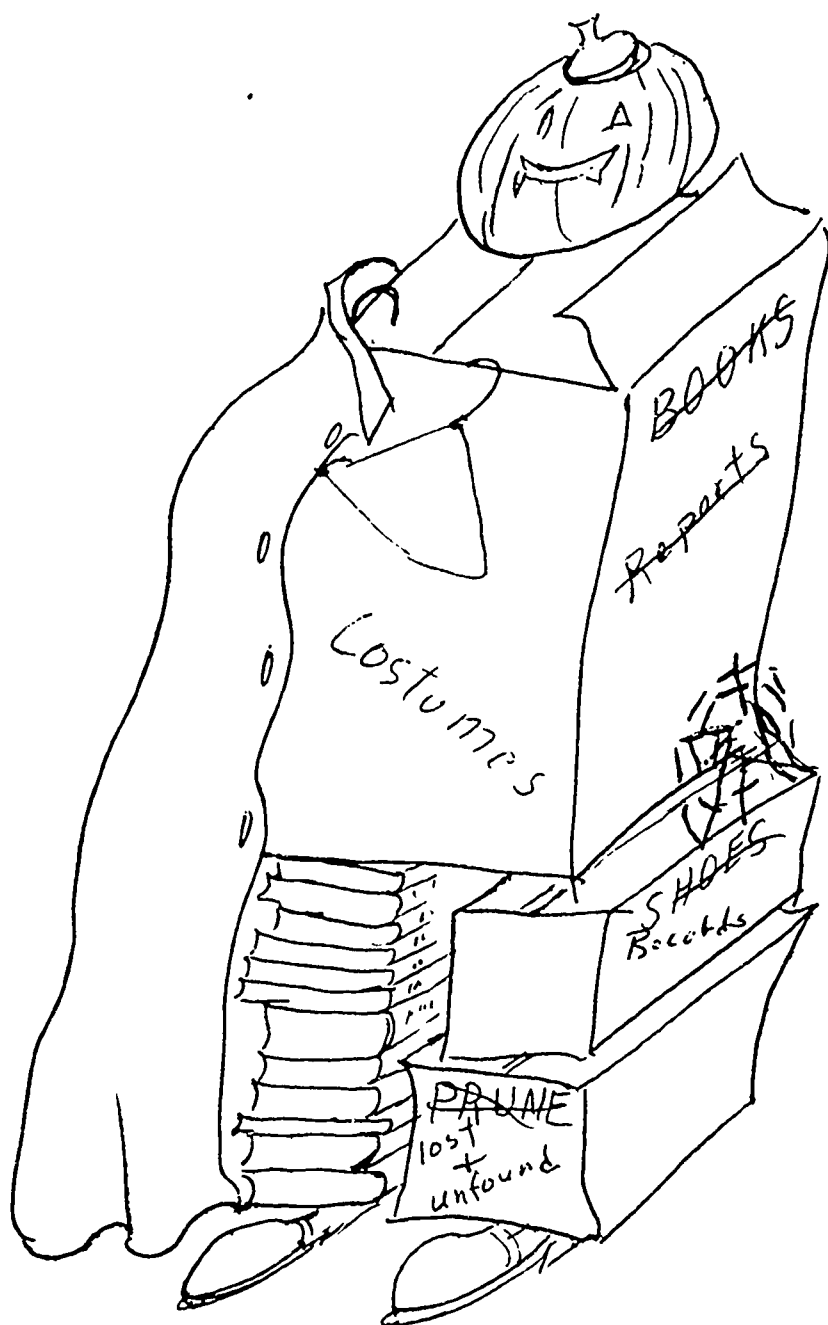

JUNKY McCLUTTER

This known space thief has reportedly been seen in this school. He specializes in gathering goodies from principals, teachers, and custodians which are "things we might need sometime." He has stolen thousands of closets, bookshelves, cabinet shelves, attics, basements, boiler room corners, etc.

He is wanted for arson in several places. If you see him, don't report it - burn him. Reward - usable space safe from fire hazard.

A SAMPLE FORM

I N V E N T O R Y C U S T O D I A L S U P P L I E S

_____ Date

_____ School

_____ Custodian

ITEM	AMOUNT	ITEM	AMOUNT
Towells, Paper	4 Cases		
Toilet Paper	4 Cases		
Bowl Cleaner	6 Qts.		
Cleanser, Powder	1 Case		
Detergent, 5 gal. cans	4		
Treatment, dust mop	3 Qts.		
Mopheads, dust 24"	12		
Mopheads, Wet 24 oz.	6		
Mopheads, dust 48"	4		
Sealer, Wood (gym)	3 Gal.		
Sealer, Asphalt Tile	2 Gal.		
Floor Finish			
(Synthetic Wax)	11 Gal.		



A SAMPLE FORM

I N V E N T O R Y

CUSTODIAL TOOLS AND EQUIPMENT

Date

School

Custodian

ITEM	NUMBER	ITEM	NUMBER
Vacuum, Wet/Dry Ser. No. 123456	1		
, Wand	1		
, Squeegee	2		
, Carpet Tool	1		
Floor Machine Ser. No. 654321	1		
-Backing Block for Pads	1		
-Scrubbing Brush	1		
-Buffing Brush	2		
Tool Box	1		
Wrench, Pipe 18"	1		
" , Adjustable 12"	1		
" , Open End	6		
Hammer, Claw	1		
Hand Saw	1		
Hack Saw	1		
Screwdriver	4		
Putty Knife	4		

EFFLORESCENCE

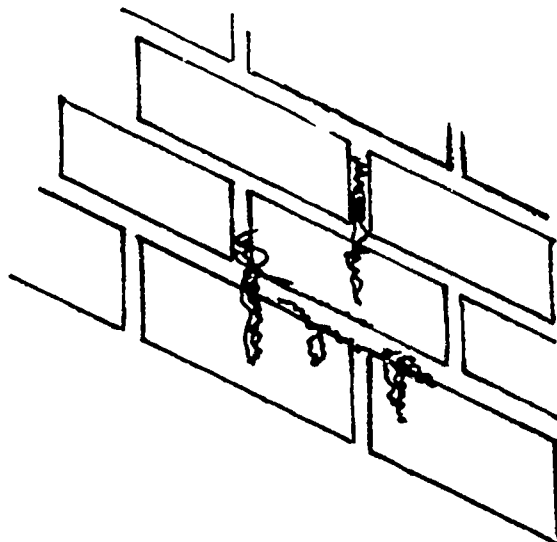
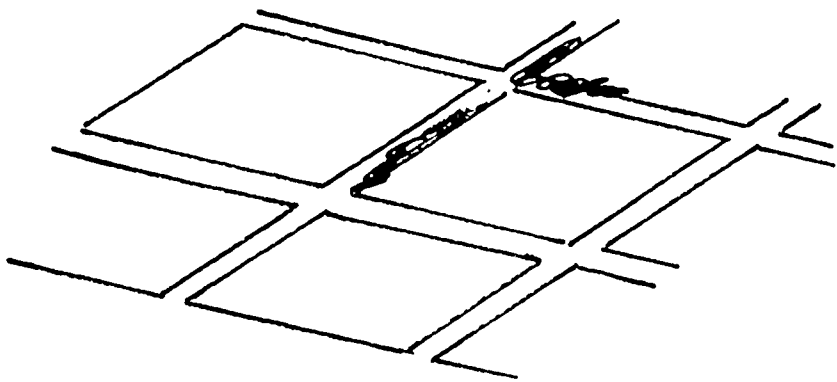

What Is It?

A white or grey crusty deposit found on masonry walls inside and outside tile joints, mortar joints, or wherever cement is used.

What Causes It?

Water that has dissolved mineral salts within the masonry comes to the surface and evaporates. It leaves the minerals as a deposit on the surface.

How Is It Removed?

Scrubbing, wire brushing or scraping will remove most of the deposit. A mild hydrochloric or muriatic acid solution will remove the stain. The deposit will return unless the cause is eliminated.

How Is It Prevented?

Stop the water from getting into the cement or masonry. If it is a ceramic tile, concrete, or terrazzo floor, apply a penetrating sealer when thoroughly cleaned and dry. If the deposit is on walls, determine how water got into the wall and stop it. (Maybe it is a roof leak.) In some cases, experienced masonry experts will need to be consulted.

REMOVING STAINS FROM MASONRY

The following suggested methods of removing stains may be used on masonry surfaces, such as concrete, terrazzo, ceramic tile, quarry tile, or any Portland Cement materials. Some of the methods may work satisfactorily on other materials, but it must be remembered that the harsh chemicals may be more harmful to the surface being cleaned than the soil itself. A good rule to follow when working with new products and methods, especially chemicals, is to try them on scrap material or in some out-of-sight area.

The following cautions must be understood and followed:

1. When using acids, protect the hands.
2. Avoid breathing any fumes.
3. Always neutralize acids with alkalies or by diluting to harmlessness with water.
4. Always neutralize strong alkalies with mild acids or by diluting to harmlessness with water.
5. Never use highly inflammable liquids when flames or sparks may be in building.
6. Avoid using potent materials when children are around.
7. Store harmful materials in a safe locked place.
8. Label all harmful materials properly.
9. The following methods of cleaning stubborn stains are to be used only after the usual cleaning methods have been tried.

STAIN

METHOD OF REMOVAL

- | | |
|--|---|
| Aluminum
Metal Marks | <ol style="list-style-type: none">1. Scrub with cleanser.2. Apply hydrochloric acid with a swab. . then
rinse well. |
| Blood | <ol style="list-style-type: none">1. Wash with cold water.2. Wash with scouring powder and cold water.3. Bleach with household bleach or hydrogen peroxide. |
| Carbon Soot | <ol style="list-style-type: none">1. Scrub with detergent.2. Scrub with scouring powder.3. Clean with wallpaper cleaner.4. Bleach if necessary. |
| Coffee, Tea
Food | <ol style="list-style-type: none">1. Wash with detergent.2. Scrub with scouring powder or trisodium phosphate.3. Bleach. |
| Copper
(Tool Marks) | <ol style="list-style-type: none">1. Abrasive cleaner.2. Wash with nitric acid (1 to 9 parts water). |
| Copper Salts
Copper Sulphate,
etc. | <ol style="list-style-type: none">1. Apply ammonia full strength, then wash. |
| Crayons
(Wax) | <ol style="list-style-type: none">1. Scrape, try to remove dry.2. Dissolve with acetone. |
| Fingernail Polish | <ol style="list-style-type: none">1. Use fingernail polish remover - lacquer thinner.2. Acetone may be used. |

STAIN

METHOD OF REMOVAL.

- | | |
|---------------------|--|
| Hard Water Deposits | <ol style="list-style-type: none">1. Dissolve with vinegar, acidic acid.2. Dissolve with hydrochloric acid or muriatic acid. (For mild solution, use 1 part hydrochloric acid to 9 parts water; for strong solution, use 1 part hydrochloric to 4 parts water.) |
| Grease, Tallow Fats | <ol style="list-style-type: none">1. Scrub with detergent or cleanser.2. Hot solutions of 1 part sal soda to 4 parts, or 1 part lye to 4 parts water. |
| India Ink | <ol style="list-style-type: none">1. Scrape, then use bleach. |
| Inks and Dyes | <ol style="list-style-type: none">1. Scrub with water and detergent.2. Use bleach. |
| Iodine | <ol style="list-style-type: none">1. Scrub with alcohol.2. Wash with ammonia (full strength).3. Wash with sal soda (1 part soda to 8 parts water) or soda lye (1 part soda lye to 4 parts water). |
| Iron | <ol style="list-style-type: none">1. Apply hydrochloric acid solution (for mild solution, use 1 part acid to 8 parts water; for strong solution, use 1 part acid to 4 parts water). |
| Lipstick | <ol style="list-style-type: none">1. Remove the wax base with cleanser, then use bleach for the dye.2. Scrub with tetrachloride. |
| Mercurochrome | <ol style="list-style-type: none">1. Apply bleach.2. Apply laundry hypochlorite (a bleach), then apply vinegar. |

STAIN

METHOD OF REMOVAL

Oil

1. Scrub surface oil with detergents or cleansers.
2. For oil stain that has penetrated into masonry, apply a paste made up of 1 pound of trisodium phosphate per gallon of water and add whiting to make a paste. Apply paste half-inch thick over stain. Let dry for 1 day. Remove and repeat if needed. Wash area with water.
3. Apply commercial de-greasing products used on auto garage floors.
4. Gasoline or naphtha may be used to remove surface oil, but must be used with caution.

Paint

1. Scrub with paint solvent.
2. Use commercial paint remover.

For stubborn paint stains - Water Base Paint:

Clean with hydrochloric acid (1 part acid to 9 parts water), concentrated soda lye or acetone.

Oil Base Paint:

Clean with turpentine, naphtha, benzine, Acetone concentrated soda lye.

Synthetic Resin Paint:

Clean with benzine, acetone, methyl ethyl ketone, tetrahydrofuran.

Rust

1. Apply lemon juice.
2. Apply hydrochloric acid and water (mix 1 part acid to 8 parts water) or for strong solution, mix 1 part acid to 4 parts water.

Shoe Polish

1. Try a solvent such as turpentine or alcohol.

Tar and Pitch

1. Use a petroleum solvent as gasoline or kerosene, naphtha, benzine, or carbon tetrachloride.

STAIN

METHOD OF REMOVAL

Tobacco

1. Use cleanser.
2. Apply bleach.

Urine

1. Scrub with cleanser or trisodium phosphate.
2. Sprinkle cleanser around water closet or urinal and leave overnight.

Vegetable Stain

1. Scrub with cleanser or trisodium phosphate.
2. Bleach with hydrogen peroxide.

Waxes

1. Use kerosene, gasoline, naphtha, benzine, or carbon tetrachloride.

SEWAGE DISPOSAL SYSTEMS

The school staff from the custodian to the Superintendent have a great responsibility to guard the health of the children and the community. The problem of pollution of streams is increasingly alarming. Improper sewage disposal is a prime cause of pollution of streams.

The school administration must provide the best sewage disposal system for the school and the school custodian and maintenance department must be responsible for proper operation. Sewage systems do not require a great amount of work but do require daily or periodic attention and understanding by the custodian.

This handbook will discuss the septic tank and its related components, the lateral system, the sand filter, and the grease trap and will discuss the sewage treatment plant of "package plants."

THE SEPTIC TANK

Proper maintenance procedures require the septic tank to be inspected at least once a year. The frequency with which it must be cleaned, however, depends on its size and the amount of daily flow of sewage into the tank. The septic tank should be cleaned when the total depth of scum and solids exceeds 1/3 of the liquid depth of the tank. In cleaning the tank, the solids should be removed; but scouring should be avoided as this kills the tank bacteria. There are no chemicals or digesting yeasts which are capable of reducing the solids in the septic tank to a point where cleaning is unnecessary. Solids should be

removed from the septic tank preferably in the spring of the year because warm weather hastens the formation of bacteria within the tank. Septic tanks are frequently damaged by heavy trucks or equipment moving over the area under which they are located. A diagram of the system should be available to guide vehicles away from the critical area. If there is not a way to avoid crossing the sewer line, a cast iron pipe, instead of clay tile, should be installed under the crossing.

THE LATERAL SYSTEM

The sub-surface disposal system, or the lateral field, consists of a two foot trench with 6 inches of rock over and under farm tile which allows water from the septic tank to seep into the soil. The number of linear feet of the sub-surface disposal system depends upon the ability of the soil to absorb water and the daily amount of water that enters the field. Lateral system failures may occur if septic tanks are not cleaned at proper intervals which allows sludge to fill the pores, or if the lines are crushed by trucks or heavy machinery.

THE SAND FILTER

Digested sewage from the septic tank may be dissipated by a sand filter instead of the lateral field. The septic tank sludge is automatically siphoned into the sand filter which seldom creates an odor if the sludge has been properly digested. If an odor persists, the septic tank should be cleaned and then seeded with digested sludge. Care should be exercised to keep the sand free of weeds,

to remove the crust-like material which forms on top of the sand, and to insure that the siphons are operating properly. The sand filter should be fenced and the gate locked to prohibit children from the area.

THE GREASE TRAP

Grease traps require the same manner of cleaning as septic tanks, except that grease traps should be scraped or scoured clean and flushed with a hose. Grease should be removed regularly from the top of the liquid, and solids that will settle should be removed at least once a month. If odors occur about the grease traps, it is probable that the top is not well seated, that cleaning may be required, or that discharge line has become blocked. With the use of modern detergents, grease traps should have a capacity to hold the discharge from the sink of the dishwasher for a twenty-four hour period. Grease traps should discharge into the septic tank and not directly into the sub-surface disposal system.

SEWAGE TREATMENT PLANTS

As population increases and the size of schools grow, the danger of pollution and sewage disposal multiply. The prefabricated "package plants" give us a potentially improved method of sewage treatment. But like most equipment, they have increased the need for operating knowledge.

The manufacturers of treatment plants usually instruct the purchaser in the proper operation of their products. Manuals of instruction are furnished with each installation. It is very important that the school plant operator study the operator's manual and understand all functions of sewage treatment plant operations. The school maintenance department personnel and the school custodians should avail themselves of the opportunity to learn all aspects of treatment plant operation. The custodian who will care for the sewage plant daily must understand his duties and be able to detect any malfunctions. The school maintenance department's tradesmen must be prepared to promptly answer any request or need for repairs or assistance.

Specific instructions for treatment plant operations should be obtained from the maker of the particular plant installed, but there are some general recommendations and suggestions which are appropriate here.

1. There should be posted in the custodial office or central storeroom specific instructions as to what the custodian is to do daily, weekly, monthly, etc. These instructions should specifically tell the custodian how to detect improper operation and what to do about it.

2. The package plant is almost odorless when properly operating: but when visitors or the public see sewage or sewage plants, they often think they smell it, even if they can't. For this reason, the sewage plant, or sand filters, should be screened from public view by well-planned plantings of shrubs or trees, preferably evergreens.
3. A fence with a gate and padlock should be erected around every sewage plant or filter pit. A child could drown in a treatment plant.

THE WATER SUPPLY SYSTEM

Custodians of schools that are served by municipal water supply systems need only to keep the facilities clean, operative, and protected against freezing. Many schools, however, are served by water supply systems that are school installations and must be properly operated and maintained to insure adequate and safe water. The school custodian is usually responsible for the operation of such a water supply system. He should determine the operational requirements of the water supply system and render such service requirements regularly and efficiently.

Various sources of water supply such as springs, wells, and cisterns are presently in use and must be properly utilized for satisfactory service. Whether a hand pump or an automatic pumping and purifying system is used, the water supply source must be protected; and the pumping, purifying, and dispensing facilities must be properly maintained. The following are minimum requirements in providing safe water:

1. Keep top of well or cistern well sealed by concrete slab and close-fitting cover.
2. Drain surface water away from well or cistern, and do not allow it to accumulate within 100 feet of the well or pump.
3. Do not allow livestock to pasture within 100 feet of the well site.
4. Keep air vents, overflows, and filters open and properly screened.
5. Do not prime pumps with impure water.

Automatic pumping and purifying water systems need regular attention. Both the pump and the chlorinator require services of a specialized nature. The custodian must be sure that he understands this operation and has the necessary supplies and repair parts to insure continuous service. Chlorine solutions must be properly prepared and applied. Pump parts must be inspected, oiled, and serviced. Water leaks must be serviced or reported, and tanks and lines must be protected against rust, freezing, and other hazards.

Disinfecting of wells or cisterns for regular use may be done by adding one cupful of Clorox or Purex for each 1,500 gallons of water in the well or cistern. One ounce of chlorinated lime (20-25% available chlorine) mixed into a water solution is adequate for disinfecting 4,000 gallons of water. Other water disinfecting agents are available and may be used according to directions. After adding any disinfecting agent to the well or cistern, allow thirty minutes before use. Wells or cisterns that have become contaminated must be properly disinfected and pumped out before they are again used for water supply. When in doubt about the safe use of any water supply, send a sample in a sterile container to the Division of Engineering, State Health Department, for analysis.

GARBAGE DISPOSAL

Proper disposal of garbage and debris is an ever present problem of the school lunchroom. The problem is most serious in areas where no municipal disposal service is available. The school principal, the lunchroom manager, and the school custodians are jointly confronted with the problem. A definite administrative policy is necessary in order to place the responsibility and develop ways and means of solving the problem. The school custodian is involved in the problem to the extent and degree that is defined by the administrative policy of the Superintendent.

It is suggested that a conference be held at the beginning of the school year and, in terms of the superintendent's policy, that a specific program be developed for care and disposal of lunchroom garbage and debris. If a contract is formed for commercial garbage disposal service, it should specify various details such as nature of service, monetary considerations, care of the containers, and frequency of the proposed service. If garbage is to be burned or buried, appropriate provisions must be made for such disposal. Every school should have its own incinerator to take care of paper and trash, but they should not be used for wet garbage. The school furnace should never be used for an incinerator.

Garbage attracts numerous insects, particularly flies which feed and multiply in unprotected garbage receptacles and sometimes rise in swarms from dumps in which garbage or other organic wastes are permitted to accumulate. These substances also provide food for rats and other vermin and may

support a large number of rodents and insects. Proper disposal, thus, becomes a health factor as well as a lunchroom problem.

The following concepts should be incorporated into any procedural planning and provisions for lunchroom garbage disposal:

1. Provide a designated, protected area for storage of garbage cans away from open windows and doors.
2. Keep this area clean and orderly at all times.
3. Clean up any spills immediately and use insecticide to repel insects and flies.
4. Wash all garbage cans and lids, both inside and outside, before re-use and as soon after emptying as possible. Use hot water and detergent.
5. Check for leaky seams, general service ability of containers, and fit of lids.
6. Emptied metal and glass food containers should be removed from the school daily with the non-burnable garbage.
7. Every school can afford the cost of an incinerator even if it must be a small one. It can easily be built at low cost and the labor they save will pay for them many times. Fire safety must be kept in mind when building and using the incinerator. A suggestive drawing of an incinerator of minimum size is included herein.

PEST CONTROL IN THE SCHOOL PLANT

The increase in the complexity of the school plant has produced an increase in problems of sanitation and pest control. Various rodents and insects have invaded the school plant and contributed to property damage and health hazards. Cockroaches are brought into the plant with food deliveries and act as germ carriers and food destroyers. Rats and mice gain easy access to the plant and become a constant nuisance. The food service facilities of the school plant are confronted with this problem to the extent that many schools have contracted with commercial firms for pest control service. The cost of this service is small and usually very effective when performed at regular intervals. The only effective method of control is to rid the premises of the pests and to continue to treat the area in such manner as to provide against their recurrence; thus, effective control results from continuous effort.

The school custodian, being confronted with the problem of pest control, needs to have specific information which may be obtained from local and state health or agriculture agencies. Private concerns can offer much assistance in solving this problem and can furnish the necessary chemical for the control program. The custodian must have the proper information and utilize the proper methods of pest control; otherwise, his efforts will be futile. Serious consequences may result from careless use of poisonous chemicals by uninformed or inexperienced school personnel.

FLIES

Flies can be controlled by many of the hydro-carbon residual sprays or other approved insecticides. The outside source of the fly problem must also be controlled. Cafeteria garbage must be disposed of promptly. Garbage cans should be stored properly and cleaned periodically. Trash piles should not be permitted to exist. Eliminate food and breeding places to effectively control flies.

RATS AND MICE:

Rats and mice can be effectively controlled by one of the anti-coagulant compounds such as warfarin, properly prepared and distributed in strategic locations.

Controlling rats and mice will be an unending task if breeding places and food sources are not eliminated. Trash and rubbish must be eliminated. Garbage elimination should be efficient. Proper use of an incinerator will greatly reduce the chance of a pest problem.

ROACHES

The presence of roaches is a sure indication of a sanitation deficiency. Roaches, being scavengers, will eat almost any animal or vegetable matter. They feed on sweet or starchy foods, bakery products, cheese, meats, fruits, hair, leather, glue, etc.

Roaches feed at night and, for this reason, may be present in large numbers without being noticed. If roaches are seen during the day, one can be

sure there are many, many around. To best determine if roaches are present in the school, go quietly into likely places in the late hours of night and turn on the lights.

Roaches can come into a building by walking or flying, or by being carried on or in food boxes or bags. Movement of trash and garbage may move roaches from place to place.

Roaches are undesirable in the school, not only for their appearance and association with filth, but also because of their disease carrying traits. In addition to transmitting diseases, roaches secrete an oily substance which has an offensive odor. In this way, they can contaminate food, food containers, and dishes.

There are several species of roaches: the American, the brown banded, the Oriental, and the German. The first three may be killed or controlled with Chlordane, but the German cockroach cannot. Some insecticides recommended are:

Malathion - 57% Emulsifiable Concentrate, 12 tablespoons per gallon of water.

Diazinon - 25% Emulsifiable Concentrate, Premium Grade, 10 tablespoons per gallon of water.

Ronnel (Korlan) - 24 % Emulsifiable Concentrate, 10 tablespoons per gallon of water.

Malathion - 5% Dust

Diazinon - 2% Dust

Sprays or dusts should be directed into cracks and hiding places where roaches live or hide. Inspect probable places in kitchen, cafeteria, home eco-

nomics rooms, custodial storerooms, garbage can shelters, incinerator areas, and other likely spots. BE VERY CAREFUL WHEN USING INSECTICIDES AROUND SCHOOLS. Read and obey labels and instructions.

To control roaches effectively, spraying or dusting must be repeated several times at thirty-day intervals. Sanitation is a must. Sources of food, water, and shelter must be eliminated if pests are to be controlled.

GROUNDS CARE

The yard and playground provide the setting for the school plant and, as such, deserve the attention that reflects an orderly program. The total school program is often judged by the outside appearance of the plant and its setting. If the grounds have been well planned and developed, yard care and maintenance are facilitated to that extent. However, if grounds have not been properly developed, care and maintenance are difficult operations. A relatively small investment in planning and grading will enable great improvements in care and maintenance of the grounds.

The school custodian is usually confronted with yard and playground areas that have been predetermined with small probability of major renovation. He must envision his program in terms of minor adjustments, necessary maintenance and reasonable care. The larger area is usually devoted to playground and, as such, will not require much scenic attention except to keep it properly drained, clean of debris, and with hard surface maintained in dense traffic areas. Playground equipment will require regular inspection for proper maintenance. Out-of-season items should be reconditioned and stored for ready use. Playing fields may require some special care, and the larger area should be kept well trimmed during the growing season.

The lawn area will require careful attention to reflect a desirable atmosphere. During the growing season the scenic area will need almost daily care. Proper care of the lawn, shrubs, and trees often requires knowledge, skills, and techniques of a specialized nature for satisfactory results. The custodian

may need to acquire some specialized information and utilize improved methods and techniques in order to maintain safe, scenic and functional yard and playgrounds.

The following concepts are offered to facilitate proper care of the lawn, shrubs, and trees and are considered good practice for these operations:

AERIFYING

Most playgrounds and yards suffer from compaction caused by traffic. Aerifying is the means of cultivating these areas without disturbing the present turf. This should be done before seeding or fertilizing.

LIME

An application of 200 to 300 lbs. of crushed limestone per 1000 square feet applied March through June every two or three years usually provides good turf.

FERTILIZER

15 lbs. of 6-8-6 per 1000 square feet on existing turf, or 20 lbs per 1000 square feet of 10-10-10 on new seedlings, applied February 15 to March 30 or at the time of seeding, will supply the necessary elements for a good healthy turf.

SEEDING

Except where Bermuda grass prevails, an application of 1 to 3 lbs. of a proper seeding mixture per 1000 square feet, depending on the density of existing grass, is necessary to maintain a good turf. The best time to sow is September. The next best time is February 10 to March 10. Cut new grass as soon as it is tall enough, but never cut Bluegrass shorter than two inches.

CEMENT BLOCK REFUSE BURNER

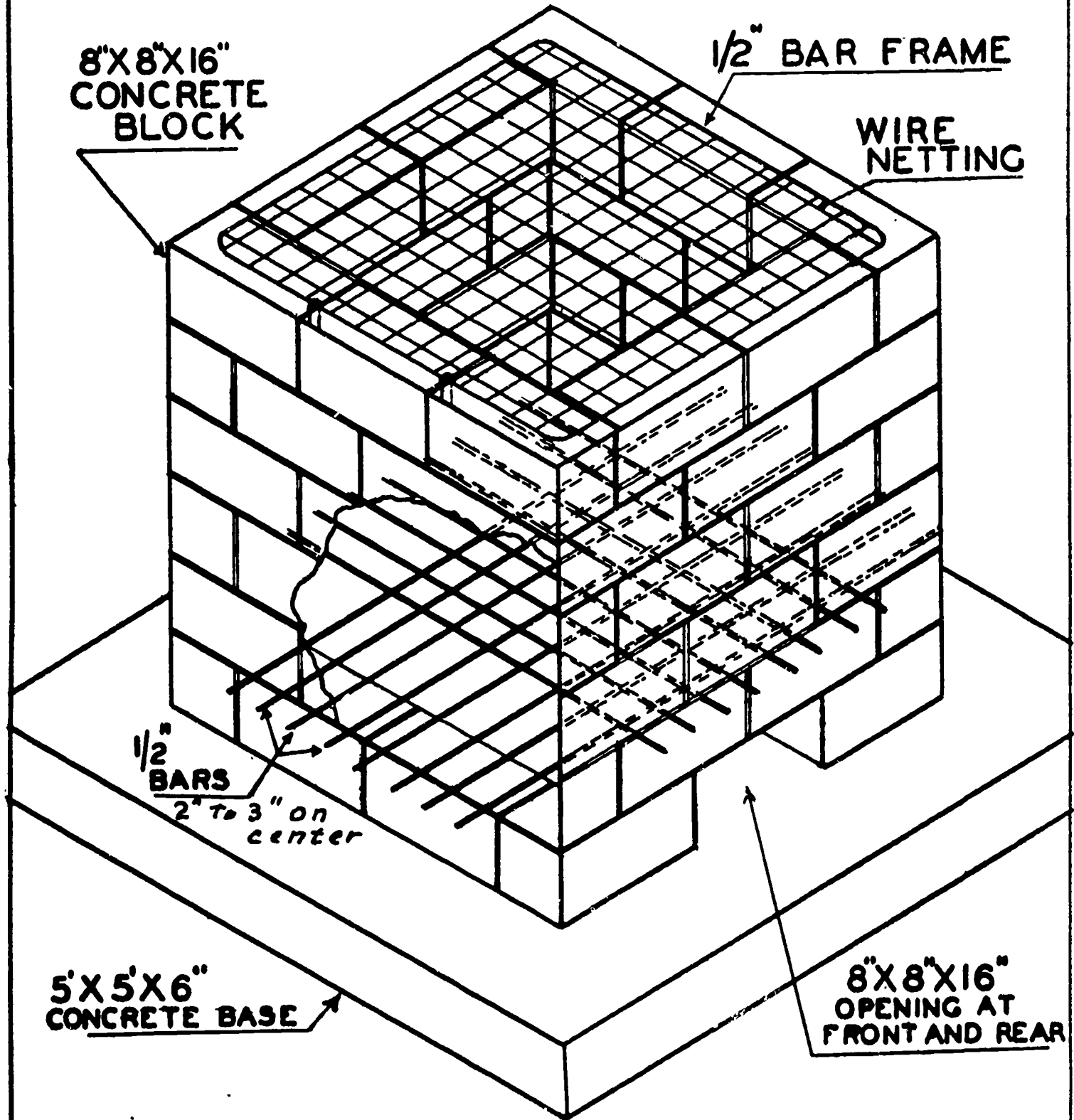

KENTUCKY STATE DEPARTMENT OF HEALTH
620 SOUTH THIRD STREET, LOUISVILLE 2, KY.

SE-0-10

TREE PRUNING

Cut off any large limbs 18 to 24 inches from the main stem to prevent the bark from peeling, then cut as close as possible to the main stem. All wounds over three-fourths inch in diameter should be painted with an antiseptic tree wound dressing.

FLOWERING SHRUB PRUNING

After shrubs bloom, remove one-third of the old canes by cutting off close to ground. Thus, the entire shrub is renewed every three or four years and is less apt to become too large or misshapen.

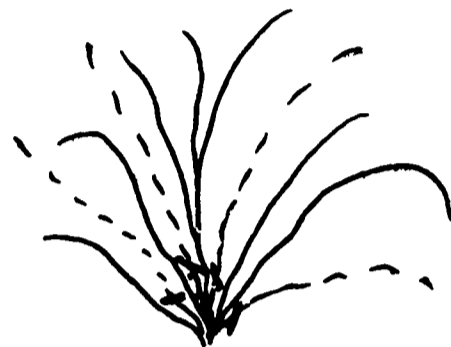

EVERGREEN PRUNING

Evergreens such as Taxus, Junipers, Hemlock, Mugho Pines, Spruces, Firs, and Broadleaf Evergreens should be trimmed or shaped by removing sufficient amounts of the current season's growth to improve their appearance. May to August is the best time to do this.



HEDGE PRUNING

Pruning is essential if hedge is to be attractive. This pruning will be required every few weeks during the active growing season. The top of the hedge should be narrower than the base so all parts of the hedge get equal amounts of light.

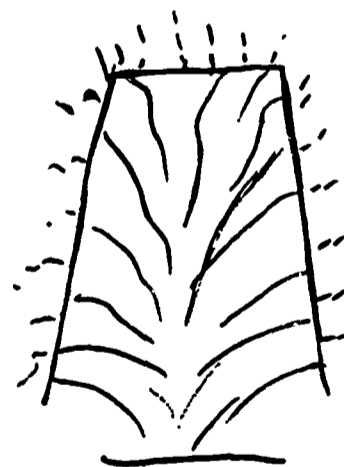

UNIT VENTILATORS

Unit ventilators are increasingly used in school construction to provide a comfortable and healthy learning situation with individual room control. These units bring in some fresh air from the outside, heat the room, and exhaust the air into corridors or to the outside through roof vents or ducts. Component parts of the unit include fresh air vents, grill covers, motors, fans (usually squirrel cage type), air filters, and controls, each of which needs the attention of the custodian. Proper care of these units require:

1. Periodic inspection of each component by the plant operator.
2. Monthly inspection of filters and (a) replacement of throw-away of filters as needed or (b) washing of permanent filters with hot water and detergent and re-oiling with odorless filter oil. (Apply oil with hand sprayer or by dipping and draining.) Sufficient throw-away filters should be on hand so that clean ones may be installed at the same time dirty ones are removed. A supply of filters should be on hand along with a sprayer used only for this purpose.

A washing tank should be made or purchased of sufficient size to accommodate several permanent filters. It should have a grid above the bottom which would allow dirt to settle. A drain board should be provided.

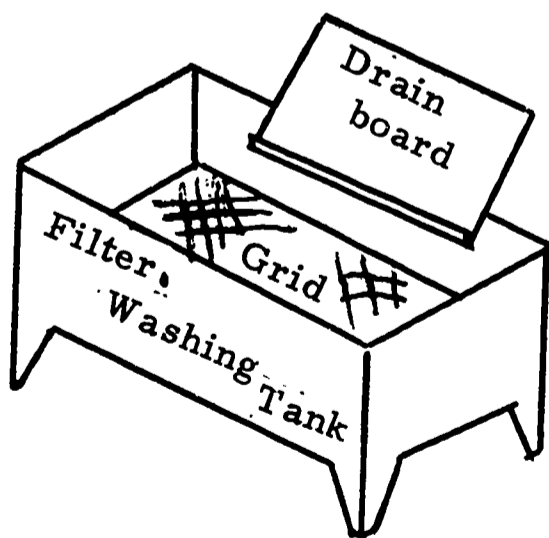

3. Inspect V-belts regularly and replace if damaged.
4. Inspect grills and outside vents and remove dirt, trash, or obstructions.

ELECTRIC MOTORS

Hardly an hour passes that we are not benefitted in some way by an electric motor in our schools. This valuable machine is too often taken for granted and ignored. (This increased usage demands that every school system have thoroughly trained electricians in its maintenance staff.)

It is true that most motors of late manufacture are almost self-sufficient, but there are several precautions and procedures that should be followed if we are to get maximum service and avoid breakdown.

FIT THE MOTOR TO THE JOB

Most equipment such as air conditioners, stokers, shop machines, etc., in the school plant are purchased with motors installed as part of the equipment. In this case, it is usually safe to assume that the manufacturer has selected the proper motor for the job. There are situations where the plant operator may need to select or render judgment as to whether a motor is adequate for a task to be performed. The plant operator can find advice and help from two sources: from printed manufacturer's instructions and from competent electricians.

CLEANING

Dust, dirt, oil, grease, water, and other foreign matter are enemies of electric motors. These substances prevent proper cooling, breakdown insulation materials, cause short-circuits, and lessen efficiency of lubrication.

1. Remove exterior dust daily with dry cloth or brush. Catch the dust before it can enter the motor.
2. Remove interior dust with compressed air (not exceeding 45 lbs. psi), vacuum cleaners, or bellows.
3. Remove excessive oil or grease before it can unite with dust to form sludge and gum or get into the insulation. Solvents or detergents may be used with proper care. Motor interiors should be cleaned only by competent electricians.

DRYING

A motor that has become damp or wet may be dried with warm air from an electric heater, warm-air duct, or similar source free from flames or excessive heat. Be sure motors are thoroughly dry before using.

LUBRICATION

Each motor type and model may require different kinds and amounts of lubricants. All lubrication should be done by a qualified electrician on a regularly scheduled basis. He should clean and lubricate all motors at least yearly and more often if use and conditions demand.

INSPECTION

The plant operator should regularly inspect all electric motors. Minor adjustments and repairs he may perform will doubtlessly avoid greater problems if ignored very long. Any problem arising which he does not completely understand should be referred to the maintenance electrician but he should accurately and completely describe the situation that the electrician may best make the repairs. The plant operator should look for:

1. Over Heating

Check ventilation, dirt accumulation, tight belts, loose belts, unaligned belts, dirty fans, etc., then consult an electrician.

2. Vibration

Check for dirty or damaged condition of belts, chains, fans, worn bearings, or driven equipment.

FUSE-CIRCUIT BREAKERS

It should be needless to say the sole purpose of fuses or circuit breakers is to protect equipment and persons. When a fuse blows or a breaker trips, the cause must be determined and cured before replacement. The plant operator should:

1. Have in each fuse box or breaker box a chart showing the outlets, lights, or equipment controlled by each fuse or breaker.
2. Mark each fuse holder as to ampere rating of fuse to be used.
3. Stock extra fuses.
4. Use fuse pullers for all cartridge fuses.
5. Never use coins, wire, or foil to by-pass a fuse.
6. Discard all blown or damaged fuses.

POWER DISTRIBUTION BOX

A Sample Arrangement

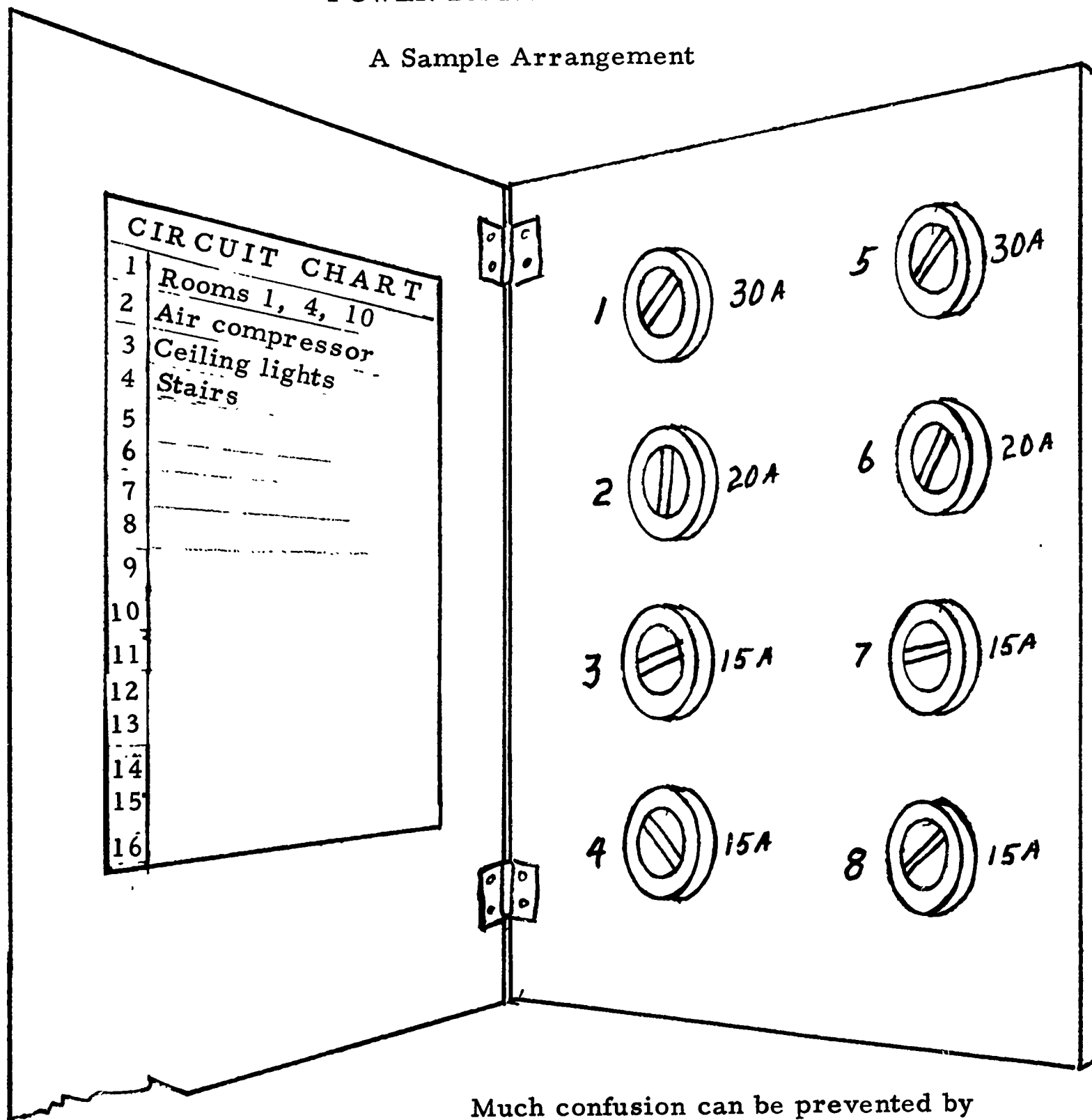

Much confusion can be prevented by good organization and planning. An arrangement such as the above example can save much time for custodians, electricians, and repair men.

1. Number each fuse or circuit breaker.
2. Mark the ampere rating of circuit near each fuse.
3. Mark the number of each circuit on a chart.
4. List the electrical items controlled by each circuit.

BOILER ROOM CARE

Boilers are classified as high pressure or low pressure depending upon whether they operate at 15 psi or less for the former. Most school boilers are of the low pressure class, but this should not mislead the firemen into a false sense of security. Ignorance, improper operation, neglect of valves and controls, and general dirty conditions can make the low pressure boiler a potentially high pressure danger.

High pressure boilers will not be discussed in detail in this manual. Their use is decreasing in schools. No fireman or plant operator should attempt to use a high pressure unit without being thoroughly qualified.

STEAM PRESSURE GAUGES

These gauges should be tested at least once during the working season while under pressure. Allow no objects or trash to interfere with these safety devices. Inspect thoroughly during the down season and replace with none but the exact type and size. Check steam pressure hourly during the operating day.

WATER LEVEL GAUGES

Check the water level hourly. Test weekly and drain glass and float chambers to remove sediment and prevent false level reading.

ELECTRICAL CONTROLS

All electrical controls should be checked periodically by a competent electrician. Many accidents are caused by abuse or faulty controls. Keep them clean, free from dust, steam, and water.

LOW WATER

In case of low water, do not add more water. Stop fuel and air supply at once. Open fire doors and close ashpit doors. For hand-fired boilers, cover the fuel fire with ashes, earth, or fine coal. Allow the boiler to cool. Inspect the boiler carefully for cracks or other damage before re-using.

FUEL STORAGE AREAS

Fuel oil tanks should be cleaned of water and sludge yearly during the off season.

Coal bins should be kept free of trash and excessive dust. Do not use the coal bins for storage. Inspect the coal periodically for heat build-up.

DO NOT USE THE BOILER ROOM AS A STOREROOM. . . . INFLAMMABLE LIQUIDS, KINDLING, AND SUPPLIES SHOULD NOT BE KEPT IN THE FUEL ROOM OR NEAR THE BOILER.

DUST CAN BE HIGHLY EXPLOSIVE AND FLAMMABLE. . . . DO NOT ALLOW DUST TO ACCUMULATE.

CARE AND OPERATION OF HAND FIRED UP-DRAFT BOILERS

STARTING THE FIRE

Fire is started in the up-draft by spreading small size coal uniformly over the grate to a depth of about 6 inches and igniting kindling placed at the rear of the grate. The ashpit doors should be open and the firing doors slightly open. This is done to avoid smoke. The first volatiles will pass up through the kindling and will be consumed. Live coals form in the rear of the grate and spread forward, releasing additional volatiles which are ignited in passing over the live coals. When the entire grate is covered with live coals, the firing door may then be closed and secondary air admitted through firing door register.

REFUELING BY THE COKING METHOD

Live coals are pushed to the rear half of the grate, and the fresh charge of coal is placed on the front half. A layer of ash should be left under the green coal to protect the grates. Because of the distillation of volatiles, the firing doors may be cracked open during the first ten minutes after each refueling.

DRAFT CONTROL

The firing rate is controlled by the ashpit damper, which may be manually operated or controlled by a damper-regulator lever on the boiler. Proper draft control improves combustion and saves fuel and labor. Sufficient combustion air must be provided by room ventilation.

CLEANING THE FIRE

Ashes should be shaken through the grate before refueling. Clinkers must be removed through the fire door, using a clinker hook. The fire bed must not be disturbed any more than is necessary to remove the clinkers and push the live coals to the rear of the grate. The mixing of ash and live coals must be avoided at all times. The ashpit must be kept free of ash accumulation.

STOKING THE FIRE

After the coal charge has been coked at the front of the grate, the crust may be broken by slicing with an iron bar. Necessary care must be exercised not to disturb, mix, or agitate the fire bed other than breaking the coke crust. The slicing is, of course, necessary because the crust formation prevents the passage of primary air upward through the fuel bed. Slicing is best accomplished by inserting the bar into the fuel bed and gently raking back and forth.

BANKING THE FIRE

Push the fire back to the rear of the grate, and cover it over with green coal.

WATER FEED AND VENTILATION

Hand fired boilers do not usually have automatic water feed controls, but water must be added by hand control valve as the need is indicated by the water gauge on the boiler. The furnace room should be well ventilated to provide air for fuel combustion.

CARE AND OPERATION OF HAND FIRED DOWN-DRAFT BOILERS

STARTING THE FIRE

Cover the upper grate with wood and kindling and place coal on top of the kindling. Light the kindling and, as the coal becomes ignited, gradually cover the entire upper grates with fuel to a depth of 6 inches. Admit air only through the upper fire doors by keeping the middle and ashpit doors closed.

REFUELING

Place fresh coal on the upper grates only after the fire has been cleaned and leveled. The lower grates should be kept covered with a layer of coke and ash which is worked down from the upper grates.

CLEANING THE FIRE

When the fuel charge has burned down, run the poker between each two adjacent rows of water tubes to work the ash and coke down to the lower grate. Level the fuel bed on both upper and lower grates to an even thickness. After this has been done, add a charge of fresh coal. The registers in the ashpit doors should be opened enough to burn the fuel which has fallen to the lower grates.

Ashes should never be allowed to accumulate in the ashpit; otherwise, overheating and breakage of the grate bars will result. Boiler flues should be cleaned at least once each week, or more often, to keep the heating surface clean.

STOKING THE FIRE

Free burning coal will burn without any attention, but high volatile coking coals will require occasional stoking. Coking coals, when heated, expand and fuse into a solid mass through which the air cannot pass. The fuel bed should be loosened sufficiently to break up the crust so that the air can pass through. This operation is done best by pushing a straight end poker under the coked coal and raking the bar until the entire bed of fuel is loose and porous.

BANKING THE FIRE

Banking the fire is done by firing in the regular manner, except that a larger quantity of coal may be added. Close both upper and lower fire doors and damper to breaching. Open the check damper to obtain the amount of draft needed to hold the fire over the desired period of time.

WATER FEED AND VENTILATION

Hand fired boilers do not usually have any water controls. The operator must watch the water level in the gauge glass and add water by the hand valve as needed. The boiler room should be well ventilated to provide proper air for good fuel combustion.

CARE AND OPERATION OF STOKER FIRED LOW-PRESSURE BOILERS

One of the most important functions of the school custodian is the care and operation of the heating plant. Man hour requirements to service the heating plant are estimated as: 1/2 hour per day for an automatic gas fired boiler, 4 hours per day for a low pressure coal fired boiler, and 8 hours per day for a high pressure coal fired boiler. The heating plant requires specialized knowledge and skills that must be mastered for proper heating plant operation. The following concepts are considered minimum essentials for heating plant operation:

CLOSING DOWN THE HEATING PLANT

1. Run all coal out of the hopper and feed tube.
2. Clean the hopper, retort, and dead plates of all coal and ash.
3. Clean all of the soot out of the boiler tubes.
4. Clean the fly ash from the rear of the bridge wall and combustion chamber.
5. Clean all coal and fly ash from the wind box changer.
6. Oil inside of hopper and run oil saturated sawdust through the stoker tube.
7. Clean soot from the fire side of the boiler, breaching, and smokestack.
8. Drain boiler, remove plugs and covers, and flush out interior.
9. Clean the outside of the furnace, boiler, and steam lines.
10. Clean the boiler room floor, walls, and ceiling.
11. Cleaning should be done soon after shutdown.

STARTING THE HEATING PLANT

1. Be sure that all furnace and boiler repairs have been completed.
2. Be sure that the stoker has been serviced and oiled.
3. See that water has attained the proper level in the boiler.
4. Start stoker to see if it operates freely and worm is not blocked.
5. Fill the hopper with uniform mixed fine and coarse coal.
6. Allow stoker to fill the retort and cover the dead plates with coal.
7. Stop the stoker and place kindling on top of the coal bed.
8. Light the kindling and leave fire doors partially open so coal will coke.
9. After fire has coked the fuel bed, turn the stoker on for furnace operation.
10. Adjust the coal feed and air supply to proper ratio for heating load.

OPERATION OF THE HEATING PLANT

1. Keep coal hopper filled with coal as the need becomes evident.
2. Check the furnace closely during the first hour of operation or until the required steam pressure is attained and automatic controls become active.
3. Inspect the heating plant every hour and observe the stoker, fuel bed, water gauge, and steam pressure.
4. Keep the fuel bed patted down hourly to break up the coke and fill air holes.
5. If too many air holes appear in the fuel bed, reduce the air supply or increase the coal feed, depending upon the amount of heat desired.

6. If too much coal is being fed into the retort, reduce the coal feed or increase the air supply, depending upon the amount of heat desired.
7. When cleaning the fuel bed, remove only the clinkers which have formed around the retort and do not disturb the retort fuel bed unnecessarily.
8. Add fresh water to the boiler as often as is necessary.
9. For weekly boiler cleaning, open the blow-down valve on the blow-off line, water column, drain line and low water cut-off. This tests the controls, as well as cleans the various parts.
10. Clean the boiler flues weekly and remove all soot and fly ash.

OPERATION OF OIL AND GAS BURNER HEATING PLANTS

DAILY CARE

1. Check oil in the worm case and fill only when the burner is idle. The proper level is 1/4" below the top of the oil cup.
2. Be sure that the boiler is filled to the proper water level.
3. The burners should be kept on rather than being shut down over weekends. There will be less operating difficulty and better overall economy by keeping the burner on instead of allowing the entire system to cool off.
4. Never close vents to the boiler room, as the burner must have ample air.
5. Keep a constant check on the fuel supply, and do not depend entirely on automatic delivery.
6. Check bottled gas supply often, and reorder before the tanks are empty.
7. Keep the burner and the entire boiler room clean. Do not allow fuel leaks. To allow the room and equipment to become dirty and to permit fuel leaks is both unsightly and dangerous.

DIRTY BOILERS DEMAND MORE FUEL

WEEKLY CARE

1. Shut off burner, wait until motor stops, swing burner open and brush off nozzle. Wipe out cup. Never use a sharp instrument on cup as damage to its lip will cause erratic flame.
2. Blow down (1) the low water cut-off valve while the burner is running, (2) the line to the water column, and (3) the boiler by opening the boiler blow-off valve.

THREE WEEK PERIOD CARE

Clean boiler flues or tubes thoroughly with metal brush. The surfaces should be scrubbed or scraped to remove the soot film caused by burning oil. A clean boiler is essential for efficient operation, and negligence is poor economy in operation. Neglecting to perform this maintenance results in high fuel costs and may cause difficulty with the burner due to clogging of flue passages.

THREE MONTH PERIOD CARE

Strainers should be cleaned (with burner off) about once every three months. The exact period will depend upon the quality of the oil used in the burner.

ANNUAL CARE

1. Have burner inspected by a competent burner man.
2. Drain and flush the worm case, and refill with high quality S. A. E. -20 oil.
3. Replace vacuum tubes in electronic controls.
4. Inspect refractory of furnace and burner throat, and repair or replace as required.
5. Have sludge removed from oil tank.



BOILER MAINTENANCE AND OPERATING LOG

Name of Building _____ Boiler No. _____ Year _____

OPERATING LOG (Weekly tests are to be recorded in spaces provided below by inserting date and initials of custodian)

YEAR	GAUGE COCKS WATER GLASSES					LOW WATER CUT-OFF FEEDWATER REGULATOR					FEEDWATER PUMP RETURN SYSTEM					SAFETY VALVES RELIEF VALVES					BURNERS FUEL SYSTEM					LUBRICATION OF AUXILIARIES				
	1	2	3	4	5	1	2	3	4	5	1	2	3	4	5	1	2	3	4	5	1	2	3	4	5					
JAN.																														
FEB.																														
MAR.																														
APR.																														
MAY																														
JUNE																														
JULY																														
AUG.																														
SEPT.																														
OCT.																														
NOV.																														
DEC.																														

MAINTENANCE LOG (At least annually, or as often as conditions indicate, the following services should be performed)

CLEAN FIRE SURFACES																																		
CLEAN WATER SURFACES																																		
OVERHAUL LOW-WATER CUT-OFF																																		
OVERHAUL FEEDWATER REGULATOR																																		
TEST SAFETY VALVE																																		
CHECK FIRING EQUIPMENT																																		
CHECK INSTRUMENTS																																		
INSPECTIONS																																		

(Use above spaces to record service dates)

FOLLOW MANUFACTURERS INSTRUCTIONS AND SUGGESTED RULES FOR CARE AND OPERATION OF BOILERS

SELECTED BIBLIOGRAPHY

FLOOR CARE GUIDE--American Institute of Maintenance
710 West Wilson Avenue
Glendale, California \$2.25

SCHOOL BUILDING MAINTENANCE PROCEDURES--

R. N. Finchum, U. S. Government
Printing Office
Washington, D. C. 20402 \$1.25

FLOOR MAINTENANCE MANUAL

Trade Press Publishing Company
1964 \$3.00

SCHOOL PLANT MANAGEMENT
ADMINISTERING THE CUSTODIAL PROGRAM

R. N. Finchum, U. S. Printing Office
Washington 25, D. C.

SCHOOL PLANT MANAGEMENT
ORGANIZING THE MAINTENANCE PROGRAM

R. N. Finchum, U. S. Printing Office
Washington 25, D. C.

*Copies may be obtained by contacting:
Director
Division of Statistical Services
State Department of Education
Frankfort, Kentucky 40601

The cost of printing this bulletin was paid from state funds.

Introductory

Resilient Floors

Masonry Floors

Wood Floors

Cleaning

Daily Floor Care

Sealing and Waxing

Refinishing

Gymnasium Floors

Restroom

Classroom

Corridors and
Stairs

Cafeteria

Auditorium

Window

Ceiling

Wall

Lighting Fixtures

Venetian Blinds

Window Shades

Furniture

Chalkboards and
Tackboards

Summer Cleaning
Program

Inspection for
Maintenance Needs

Window Repairs

Equipment and
Materials Storage

Efflorscence

Masonry Stains

Water and Sewage
Systems

Pest Control

Grounds Care

Unit Ventilators

Electric Motors

Circuit Breakers

Boiler Care and
Operation

Heating Plant
Operation

Bibliography

Floor
Maintenance

General
Cleaning
Procedure

Interior
Maintenance

Exterior
Maintenance

Heating Plant
and
Boiler
Maintenance

INSTRUCTIONS

Find section desired
by locating symbol on
the edge of the page
that matches symbol
on back cover.