

ED 024 249

Making Facilities Accessible for the Physically Handicapped. Act. No. 1 of the Public Acts of 1966.

Michigan State Legislature, Lansing.

Pub Date 66

Note- 18p.

EDRS Price MF-\$0.25 HC-\$1.00

Descriptors- *Building Design *Parking Areas, *Physically Handicapped, *Sanitary Facilities

A physical handicap is defined as an impairment which affects an individual to the extent that special facilities are needed to provide for his safety. Facilities include--(1) the special design of parking lots, building approaches and entrances, (2) stairs, ramps, doors, and multilevel floors, (3) corridors, and (4) rooms with sloping floors, fixed seats, or both. Other safety areas include special consideration of sanitary facilities, drinking fountains, telephones, location of switches, room identification, and installment of elevators. (LD)

U.S. DEPARTMENT OF HEALTH, EDUCATION & WELFARE
OFFICE OF EDUCATION

THIS DOCUMENT HAS BEEN REPRODUCED EXACTLY AS RECEIVED FROM THE
PERSON OR ORGANIZATION ORIGINATING IT. POINTS OF VIEW OR OPINIONS
STATED DO NOT NECESSARILY REPRESENT OFFICIAL OFFICE OF EDUCATION
POSITION OR POLICY.

YES ACCESSIBLE

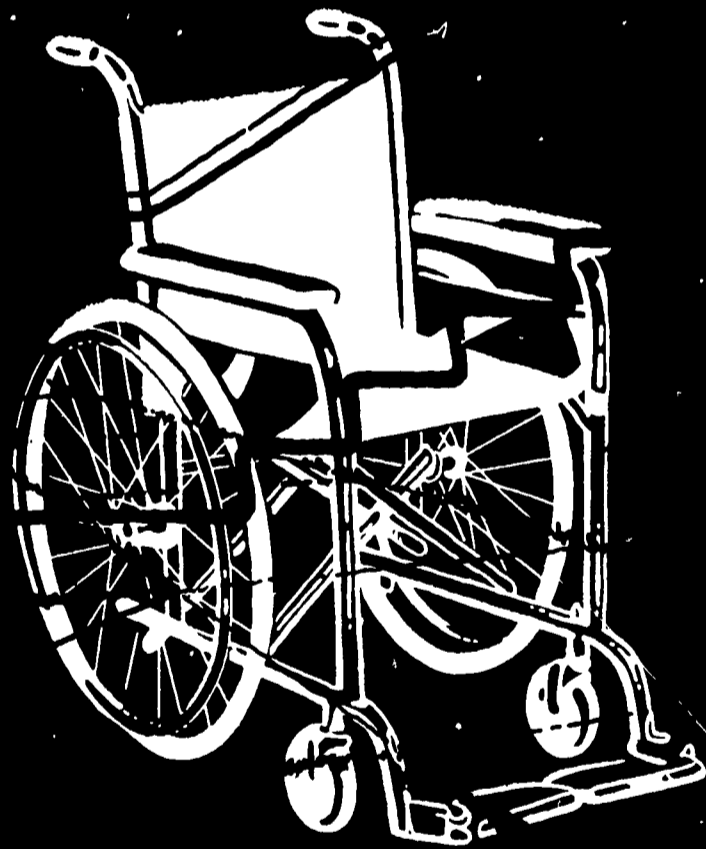

FOREWORD

It has been known for many years that the design of buildings and facilities while providing adequately for the healthy has neglected, in most cases inadvertently, to provide for the physically handicapped. The walk that is too steep, the step that is too high, the door that is too narrow, sanitary facilities that are too inconvenient, or the hazards that are unmarked for the blind, together with many other barriers prevent full participation by the one person out of every eight who is not physically normal. However, serious thought has recently been directed to alleviate or remove entirely these barriers to full accessibility and utilization.

In 1961, the American Standards Association in conjunction with the President's Committee on Employment of the Physically Handicapped approved and adopted a guide entitled "American Standard Specifications for Making Buildings and Facilities Accessible to, and Usable by, the Physically Handicapped". The guide is the result of an intensive two-year study of the barrier problem by approximately fifty different organizations concerned with solutions to these problems.

The 73rd Legislature of the State of Michigan, to ensure that no segment of our people are denied equal education, recreation, service and employment and to continue the social and economic gains in the rehabilitation of the physically handicapped, enacted Act No. 1 of the Public Acts of 1966. This Act provides for control in public building construction as it relates to that subject. The Act was signed by Governor George Romney on February 11, 1966 and after extensive research and review of all available data relevant to the problem, the Building Division, Bureau of the Budget, Executive Office, prepared the rules for administration and enforcement. These rules were officially approved and adopted

on August 15, 1967 and as of that date are to be adhered to in the design of all buildings and facilities constructed, in whole or in part, with funds of the State or its political subdivisions.

It is hoped that private owners will follow the lead of the State and provide for the design requirements outlined by the rules of Act No. 1 so that all buildings will afford equal accessibility and utilization. Actually, buildings and facilities designed to serve the handicapped also benefit the able bodied. Intelligent planning can include accommodations for the physically handicapped with a minimum, if any, of added cost and any additional expense would certainly be offset by improved accessibility and utilization for all individuals plus the savings realized by reduced maintenance and lower operating cost.

The Building Division, Bureau of the Budget, Executive Office, express their thanks and appreciation to all who assisted in the preparation of the rules. Special thanks are directed to the State Department of Education for their guidance and counsel and to those organizations and individuals who gave valuable criticism and suggestions during the public hearing held in Lansing, Michigan, on February 28, 1967 when the original draft of the rules was reviewed and discussed.

Contained herein is Act No. 1 of the Public Acts of 1966, together with the rules for compliance and sketches of recommended design criteria.

It now becomes the responsibility of governmental authorities, architects, engineers and contracting officers to enforce the rules approved and adopted on August 15, 1967. It is also a challenge to building owners and developers, together with the general public to join the program of barrier removal for physically handicapped persons in buildings not included under the scope of Act No. 1. We hope and believe the responsibility and challenge will be met.

Act No. 1
Public Acts of 1966
Approved by Governor
February 11, 1966

STATE OF MICHIGAN
73rd LEGISLATURE
REGULAR SESSION OF 1965

Introduced by Reps. Mahoney, Crowley and Snyder
Reps. White, Ford, Gray, Ensign, Petitpren and Cater named as co-sponsors

ENROLLED HOUSE BILL No. 2016

AN ACT to provide for the accessibility and the utilization by the physically handicapped of certain public buildings constructed with funds of the state or its political subdivisions and to provide for the enforcement of the act.

The people of the State of Michigan enact:

Sec. 1. As used in this act:

(a) "Physical handicap" means an impairment which confines an individual to a wheel chair; causes an individual to walk with difficulty or insecurity; affects the sight or hearing to the extent that an individual functioning in public areas is insecure or exposed to danger; causes faulty coordination or reduces mobility, flexibility, coordination and perceptiveness to the extent that special facilities are needed to provide for the safety of that individual.

(b) "Administrative authority" means the state official responsible for the administration and enforcement of the provisions of the act

(c) "Building" means a structure to which the public customarily has access and utilizes and which is constructed, in whole or in part, with funds of the state or its political subdivisions.

Sec. 2. (a) Buildings constructed in this state after the effective date of this act shall meet the requirements for the provision of access and utilization by the physically handicapped as are promulgated by the state building division except where the administrative authority determines, after considering all circumstances applying to the building, that full compliance is impracticable.

(b) Existing buildings undergoing major remodeling or rehabilitation after the effective date of this act shall meet the requirements of this act except where the administrative authority determines that full compliance is impracticable.

(c) Approval of the administrative authority shall be secured before the awarding of construction contracts for any building covered by this act.

Sec. 3. (a) The administration and enforcement of this act in respect to all public buildings, except for school buildings other than at institutions of higher education as defined in section 4, Article VIII of the state constitution, are vested in the state building division.

(b) The administration and enforcement of this act in respect to school buildings other than at state institutions of higher education as defined in section 4, Article VIII of the state constitution, which are included in section 3a of this act, are vested in the department of education.

Sec. 4. The state building division is empowered to adopt and promulgate such reasonable and standard rules and regulations for the effective administration of this act, as it shall deem necessary, after consultation with the department of education, which are not inconsistent with the provisions of this act or any law of this state. The rules authorized hereunder shall be in accordance with established practicable means for securing safety and shall be based upon generally accepted nationwide engineering standards and practices. The rules and regulations promulgated by the state building division shall be in accordance with the provisions of Act No. 88 of the Public Acts of 1943, as amended, being sections 24.71 to 24.82 of the Compiled Laws of 1948, and subject to Act No. 197 of the Public Acts of 1952, as amended, being sections 24.101 to 24.110 of the Compiled Laws of 1948.

The rules and regulations will be administered and enforced by both administrative authorities in their respective areas.

Sec. 5 Any person responsible for the awarding of construction contracts which are in violation of the provisions of this act is guilty of a misdemeanor.

Sec. 6 This act shall become effective on July 1, 1966.

This act is ordered to take immediate effect.

**RULES FOR ADMINISTRATION AND ENFORCEMENT
ACT NO. 1 OF THE PUBLIC ACTS OF 1966
EFFECTIVE . . . AUGUST 15, 1967**

R 1.501. SCOPE AND PURPOSE.

RULE 1 (1) Terms defined in Act No. 1 of the Public Acts of 1966, being sections 125.1351 to 125.1356 of the Compiled Laws of 1948, which Act is implemented by these rules, are applicable to these rules.

(2) These rules govern the design and construction of public buildings, new or with major remodeling or additions thereto and the contracts which are awarded after the effective date of these rules.

(3) These rules are intended to make such buildings accessible to and functional for any physically handicapped person employed, visiting, or on the building premises for any reason.

R 10.502. DEFINITIONS.

RULE 2 As used in these rules:

(a) **APPROPRIATE NUMBER** means the number of a specific item necessary to serve the needs of the anticipated number of physically handicapped persons who will use the building.

(b) **BUILDING DIVISION** means the Building Division of the Bureau of the Budget of the Executive Office.

(c) **CONTRACTING OFFICER** means the responsible administrative officer representing the unit of government that contracts for the construction of a building.

(d) **WALK** means a smooth, hard prepared surface of concrete, bituminous concrete, brick, stabilized gravel, or other material with the ground immediately adjacent thereto at the same level.

(e) **RAMP** means a smooth, hard prepared, sloped surface joining two different levels.

R 10.503. PARKING LOTS, BUILDING APPROACHES AND ENTRANCES.

RULE 3 (1) The parking lot servicing the entrance described in Rule 3 (2) shall have an appropriate number of parking spaces adjacent to a walkway and identified as reserved for physically handicapped persons. Each reserved parking space shall be surfaced suitably for wheelchair travel and shall be at least 12 feet wide, unless paralleling a walk. Where a curb exists between a parking lot surface and a sidewalk surface, an inclined walk or a curb cut with a maximum gradient of 1 foot in 3 feet (33 1/3%) shall be provided for wheelchair access.

(2) At least one primary entrance to the building conforming with the requirements of Rule 4 (3) shall be accessible from the parking lot or the nearest street by way of a walk uninterrupted by steps or abrupt changes in level and having a minimum width of 5 feet and a maximum gradient of 1 foot in 20 feet (5%) or a ramp meeting the requirements of Rule 4 (2).

R 10.504. STAIRS, RAMPS, DOORS AND MULTILEVEL FLOORS.

RULE 4 (1) Stairs shall have risers not exceeding 7 1/2 inches and nosings with a minimum radius of 1/8 inch. Stairs shall have handrails 32 inches above stair nosing on both sides with the handrail extended 18 inches beyond the top and bottom step on the wall side of main stair landings. Intermediate stair landings shall have continuous handrails on both sides. Stairs and landings shall have surfaces that are not slippery.

(2) An outside or inside ramp shall have a maximum gradient of 1 foot in 12 feet (8 1/3%) with a level platform 5 feet long at the top and bottom and at turns and at a maximum interval of 30 feet on long runs; and shall have a minimum clear width (inside handrails) of 32 inches. Outside and inside ramps, including platforms, shall have handrails 32 inches high on both sides with the handrail extended 12 inches beyond the top and bottom of the ramp on at least one side. All ramps, including platforms, shall have surfaces that are not slippery.

(3) A door shall have a clear opening of at least 32 inches when open. In the case of double doors without a mullion, one of the pair shall meet this requirement. The floor shall be level for a distance of 5 feet from the door in the direction of the door swing and shall extend 1 foot to the side of the latch jamb of the door. A threshold shall have a minimum rise and shall have an incline to facilitate wheelchair travel.

(4) All areas on the same floor shall be of a common level or connected by a ramp meeting the requirements of Rule 4 (2).

R 10.505. SANITARY FACILITIES.

RULE 5 (1) An appropriate number of toilet rooms and units within such room shall be accessible to, and usable by, physically handicapped persons. A toilet room shall have a clear space of at least 5 feet square to permit turning a wheelchair around. Minimum clear width in the room shall be 4 feet. A toilet stall shall be at least 3 feet wide and 4 feet 8 inches deep, have an out-swinging door (or an opening) 32 inches wide and handrails 33 inches (lower for children) above and parallel to the floor on each side. A water closet shall have a narrow understructure that recedes sharply from the front (the trap shall not extend in front of, or be flush with, the lip of the bowl). A lavatory shall be wall mounted and have a narrow apron with the bowl near the front to permit use by an individual in a wheelchair. A shelf, towel dispenser, disposal unit and the lower edge of a mirror shall not be more than 40 inches above the floor. A wall mounted urinal shall have a basin opening not more than 19 inches above the floor.

(2) An appropriate number of drinking fountains or other water dispensing means shall be accessible to, and usable by, physically handicapped persons. A wall mounted drinking fountain or cooler shall have a spout and control at the front of the unit with the basin located not more than 36 inches above the floor and shall not be fully recessed. A floor model water cooler shall have a side mounted fountain 30 inches above the floor that is accessible to an individual in a wheelchair.

R 10.506. TELEPHONES, ELEVATORS AND SWITCHES.

RULE 6 (1) An appropriate number of telephones shall be accessible to, and usable by, physically handicapped persons. Such telephones shall be located outside a conventional booth with the dial and handset not more than 48 inches above the floor. An appropriate number of telephones shall be equipped for persons with hearing disabilities and so identified with instructions for use.

(2) Elevators shall be provided in multi-story buildings to serve the floor containing the entrance meeting the requirements of Rule 3(2) and all other floors accessible to the public. The elevator cab shall have a minimum clear area of 25 square feet and a door with a minimum clear opening of 32 inches. Metal braille plates shall be provided for floor selection and other controls (open door, stop car, emergency signal, etc.) adjacent to standard floor and control buttons within the cab. The maximum height of floor and control buttons shall be 60 inches above the floor with banked button arrangement where necessary. Metal braille plates shall be provided for floor designation on each floor, 5 feet above the floor, on the fixed jamb at the open side of the elevator door.

(3) Light switches shall be located not more than 48 inches above the floor.

R 10.507. CORRIDORS AND ROOM IDENTIFICATION.

RULE 7 (1) Light fixtures, protruding signs, door closers and similar hanging objects or signs and fixtures shall not be lower than 6 feet 8 inches above the floor.

(2) Corridors shall have a minimum width of 4 feet and the end of a corridor shall have a minimum area of 5 feet square to permit turning a wheelchair around.

(3) Room identification plates (metal, plastic or other suitable material) with minimum 1 ¼ inch high raised letters or numbers, similar to a so called "super sign", shall be affixed to the wall surface approximately 5 feet above the floor, in a horizontal line, adjacent to the latch side of a door. Doors leading to dangerous areas such as fire escapes, loading platforms, switch rooms and mechanical rooms shall be equipped with knobs, handles or push bars that have been knurled.

R 10.508. SPECIAL ROOMS.

RULE 8 (1) Rooms having sloping floors or fixed seats or both, such as auditorium and lecture rooms, shall have accommodations for wheelchair individuals. These areas shall be accessible from a common level floor or by a ramp meeting the requirements of Rule 4 (2).

R 10.509. ADMINISTRATION AND ENFORCEMENT.

RULE 9 (1) The Department of Education will administer and enforce these rules for those instructional and supporting service buildings, through the twelfth grade level that are administered by public school and intermediate school districts. The Building Division will administer and enforce these rules for all other buildings.

(2) An apparent conflict between the application of these rules to a building and other state laws pertaining to the design of public buildings shall be reported to the Building Division or the Department of Education for resolution.

(3) The contracting officer shall forward, or have forwarded by the architect or engineer, one set of completed plans and specification (including those for the site development) to the proper administering agency for review. Two weeks shall be allowed for their review. If all areas of the building and its approaches are not in conformance with these rules, the plans and specifications shall be accompanied by a statement signed by the contracting officer describing the conditions or situations that warrant the exceptions and requesting that the exceptions be approved. The exceptions will be approved only when it is clearly evident that equivalent facilities and protection are provided.

(4) A notice of approval of the plans and specifications as submitted or a letter requesting changes therein will be sent to the contracting officer. Prior to the award of construction contracts the notice of approval shall be secured by the contracting officer.

(5) A change in plans or specifications affecting any part of the building covered by these rules subsequent to approval by the administering agency shall be resubmitted for approval prior to construction.

STAIRS & HANDRAILS

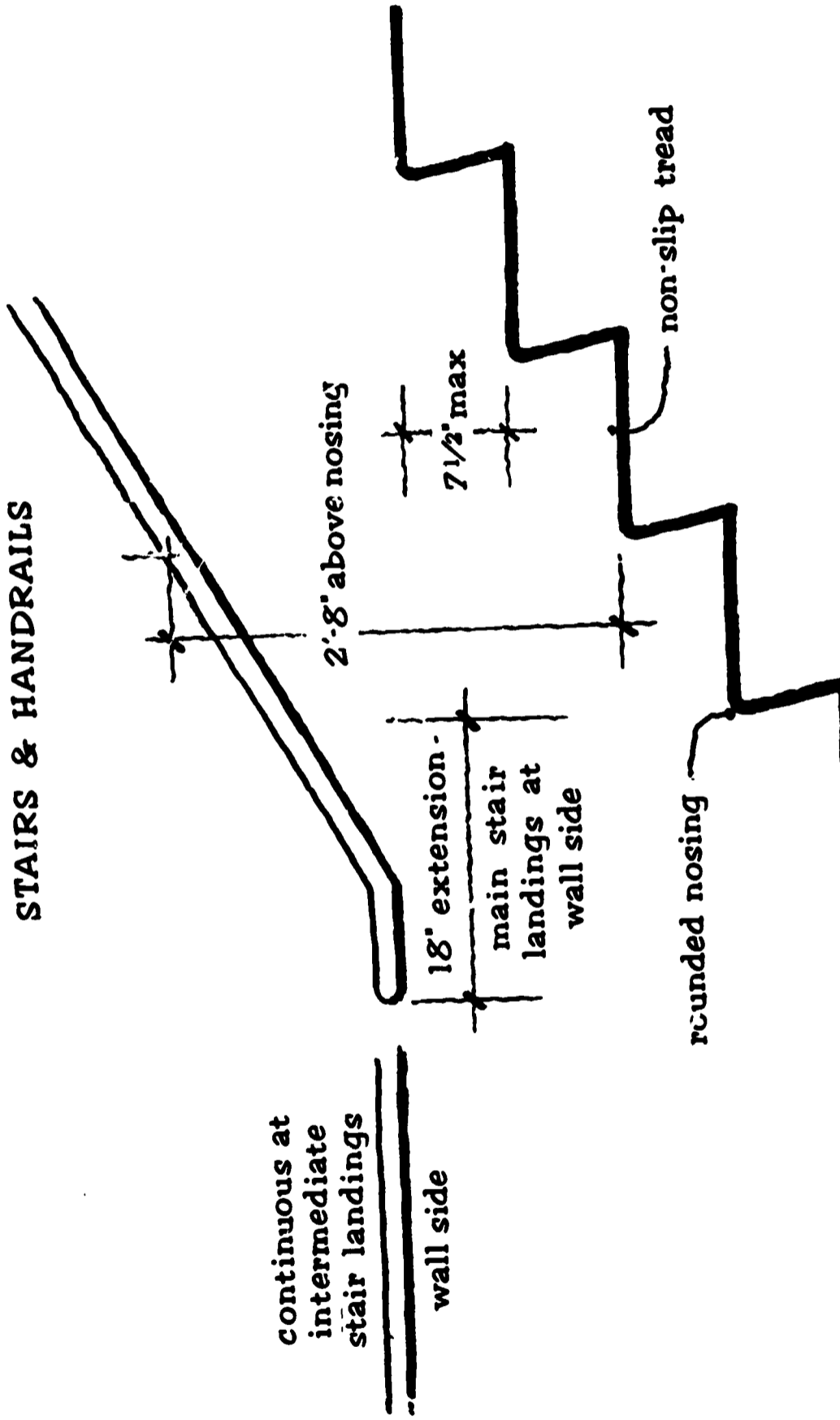

RAMPS

continuous at intermediate landings and turns - both sides

minimum ramp width 3'-0" clear if used for wheelchair traffic only - 6'-0" clear if used for all pedestrian traffic

5'-0" - minimum landing length at straight runs and at turns

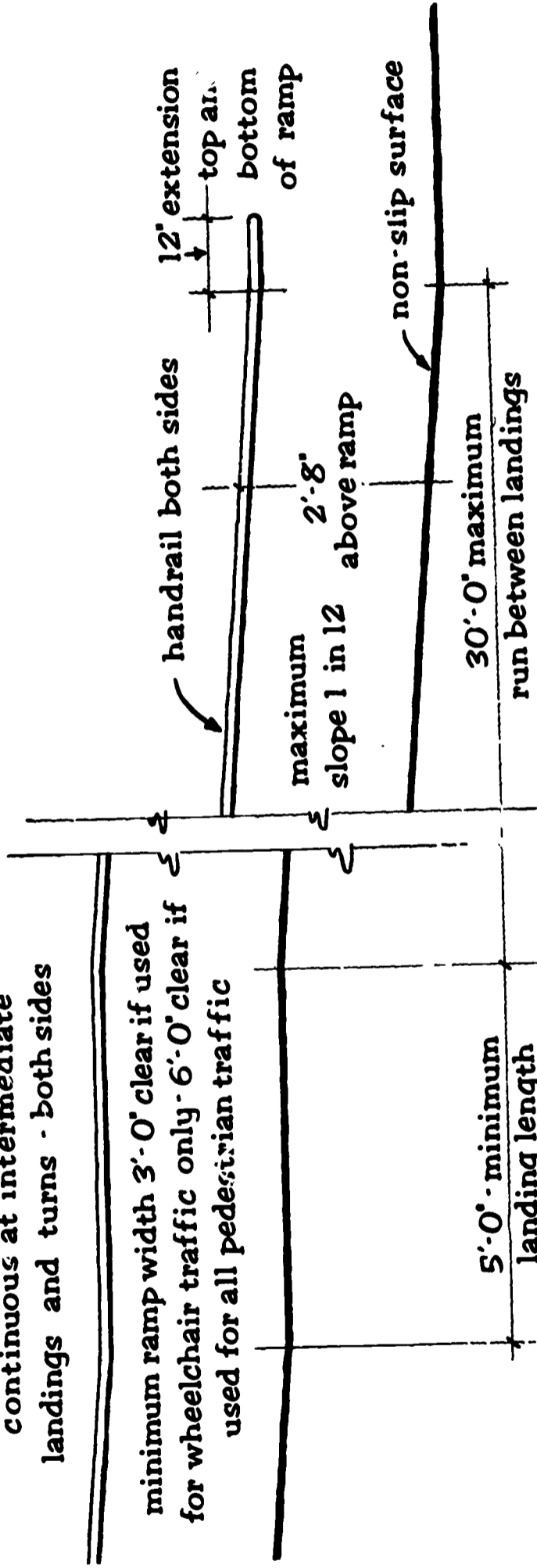

PARKING SPACES & SIDEWALK INCLINES

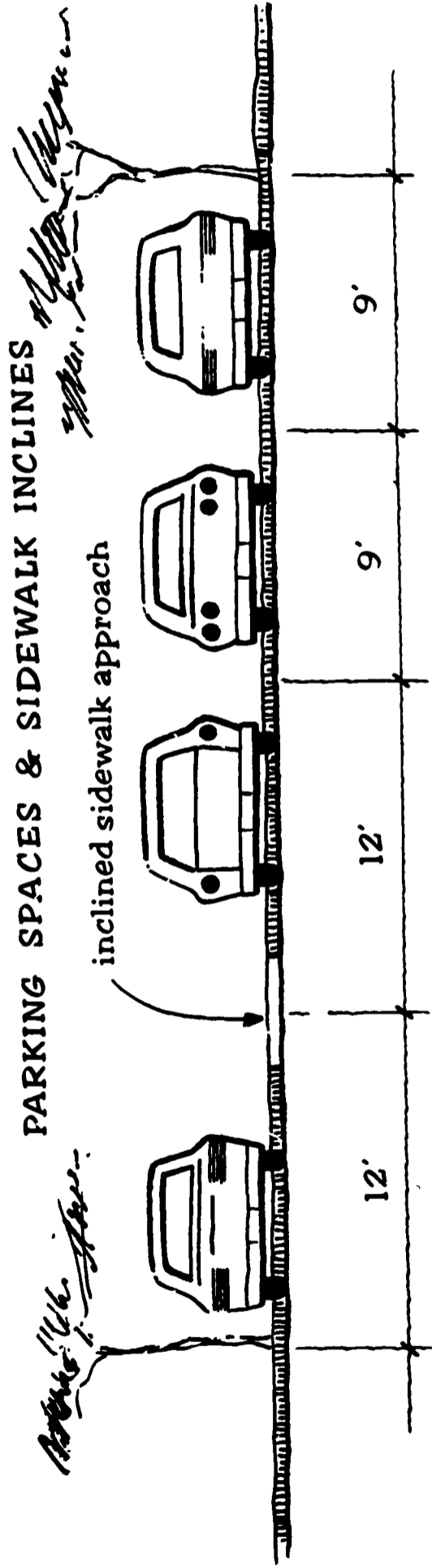

physically handicapped parking

typical parking

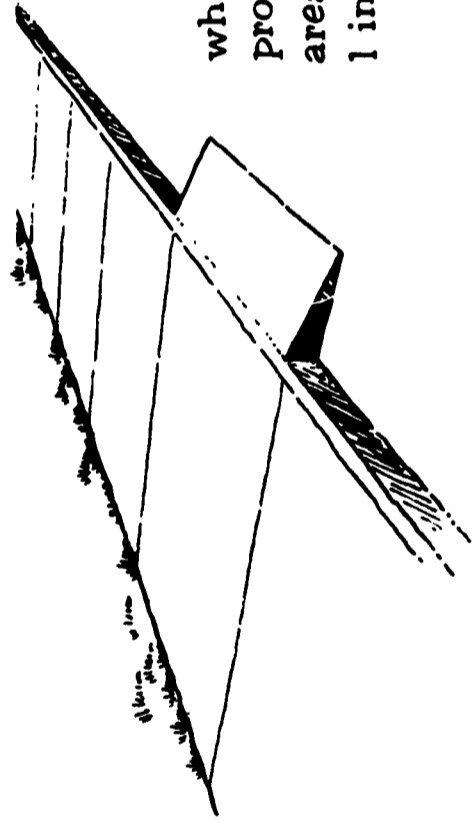

where parking abuts sidewalk
provide ramp from parking
area to sidewalk with maximum
1 in 3 slope

PARKING AREA & SIDEWALK INCLINES

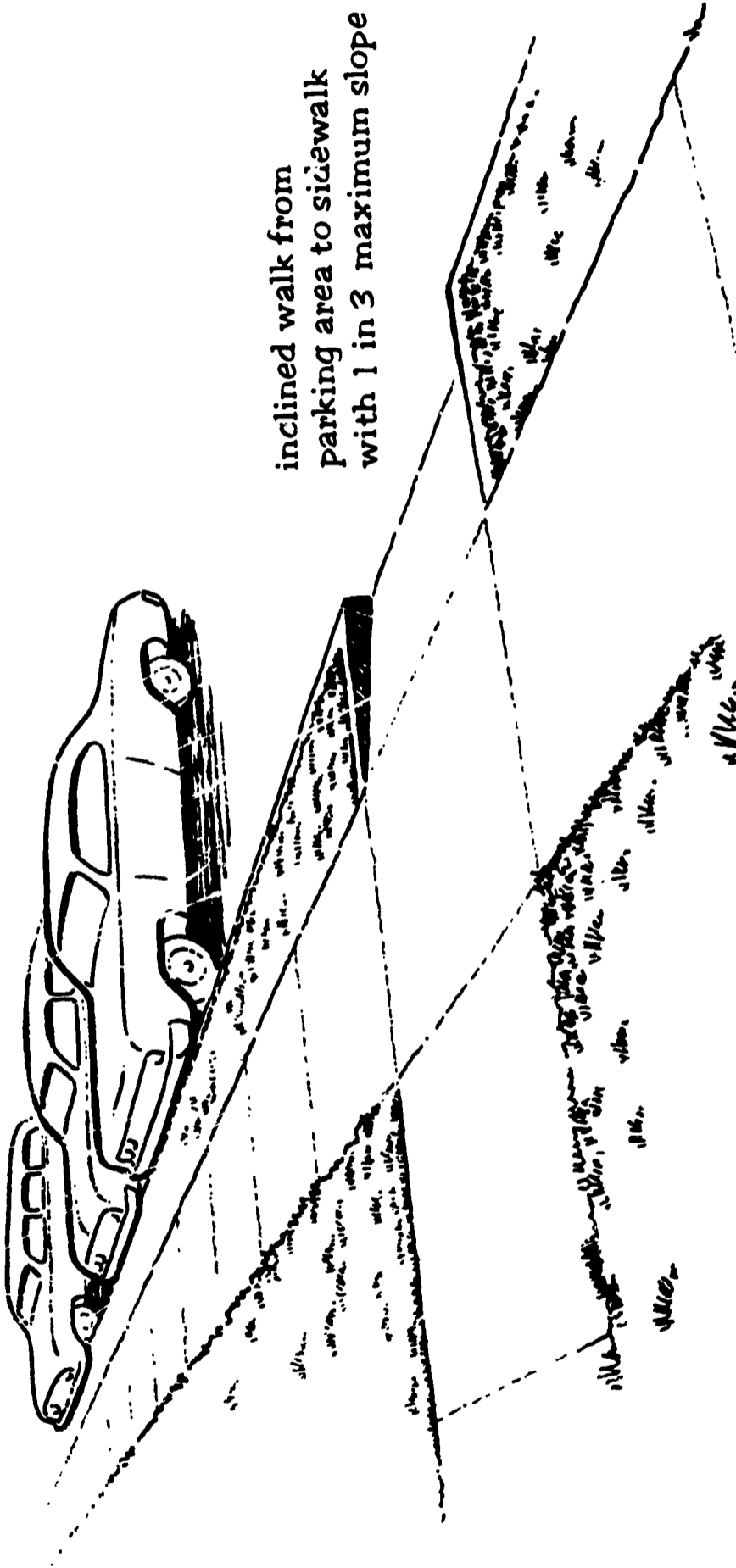

KNURLED HANDLES, KNOBS & BARS

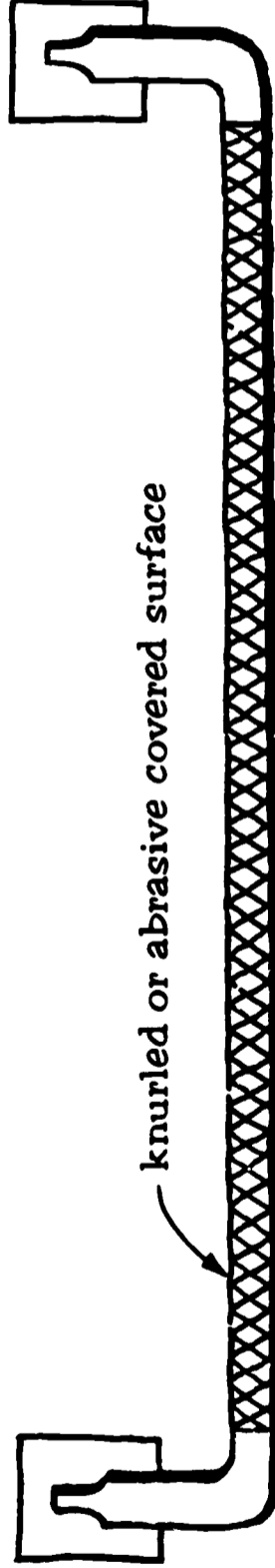
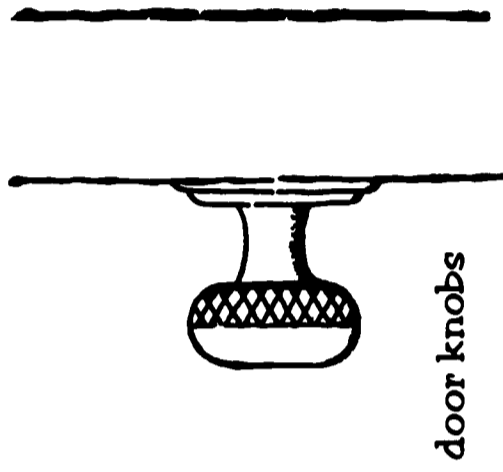
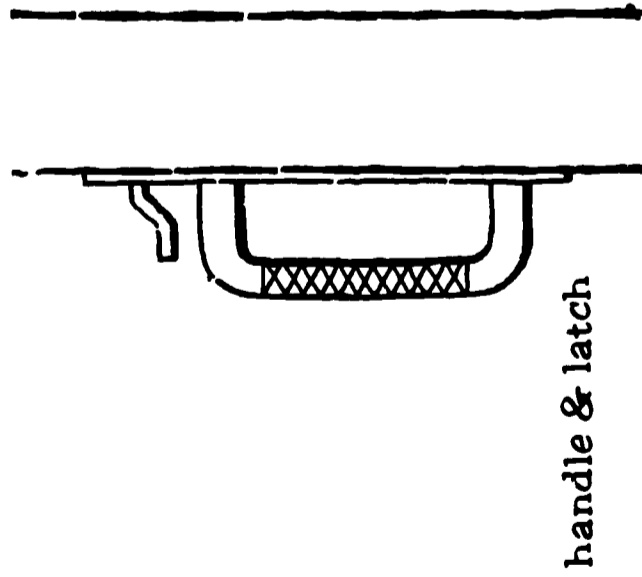

DRINKING FOUNTAINS

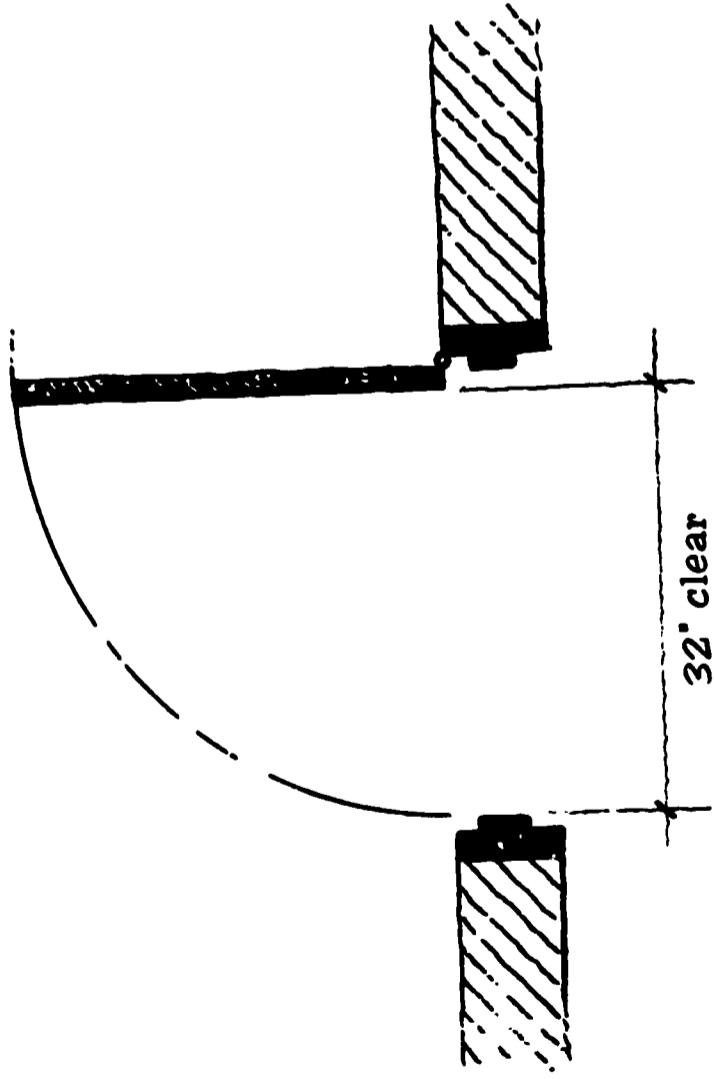
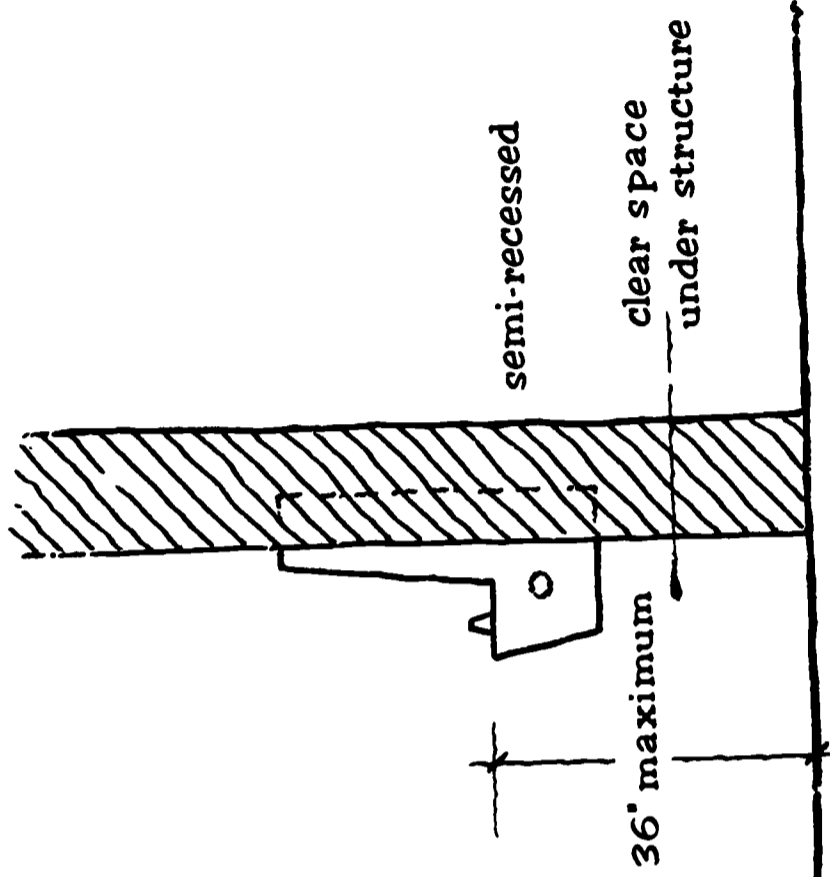

DOORS

URINALS

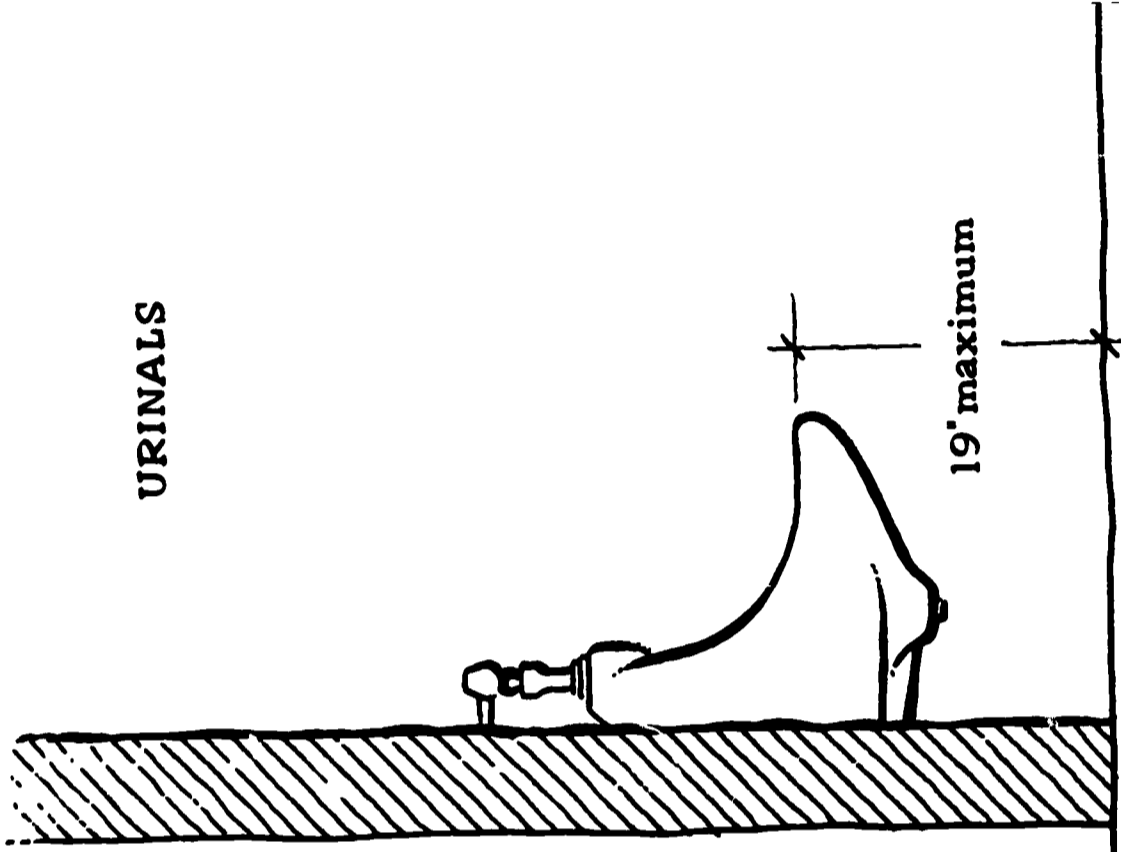

LAVATORIES

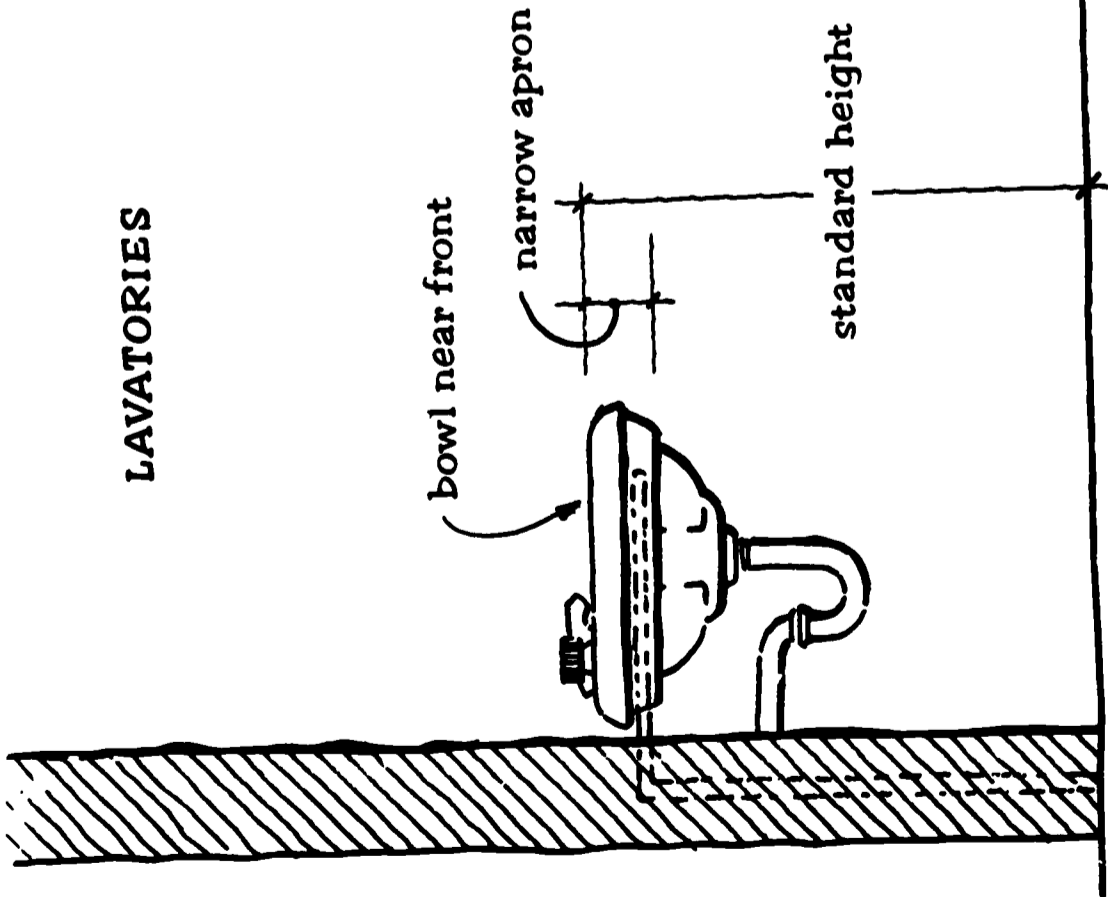

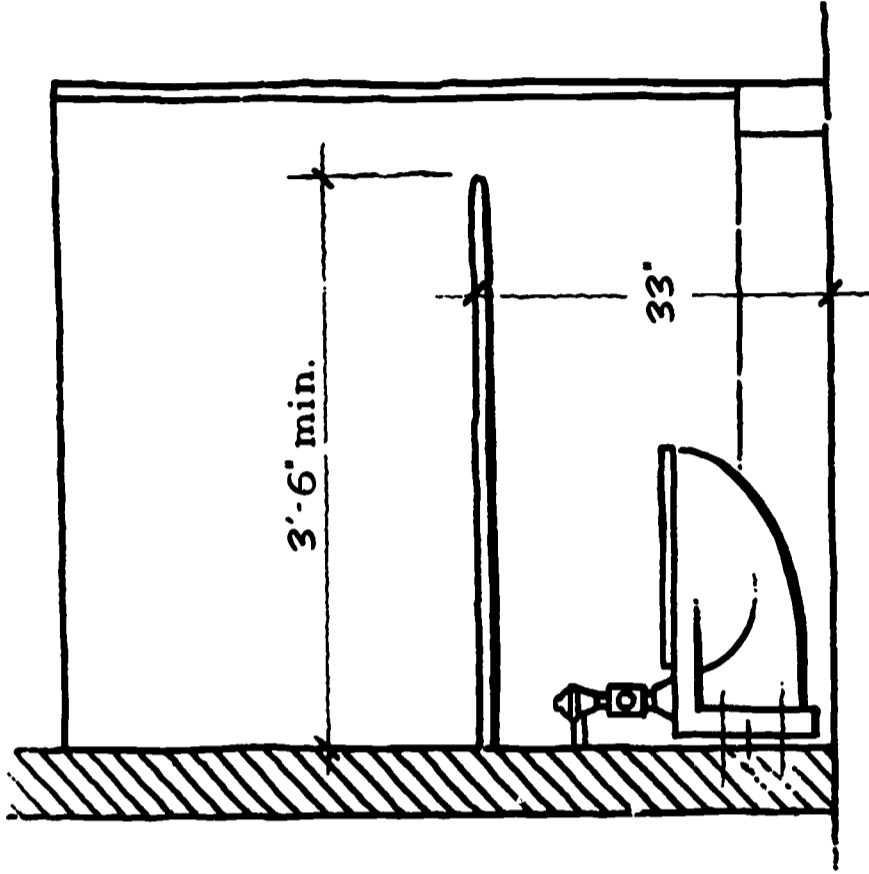

WATER CLOSETS

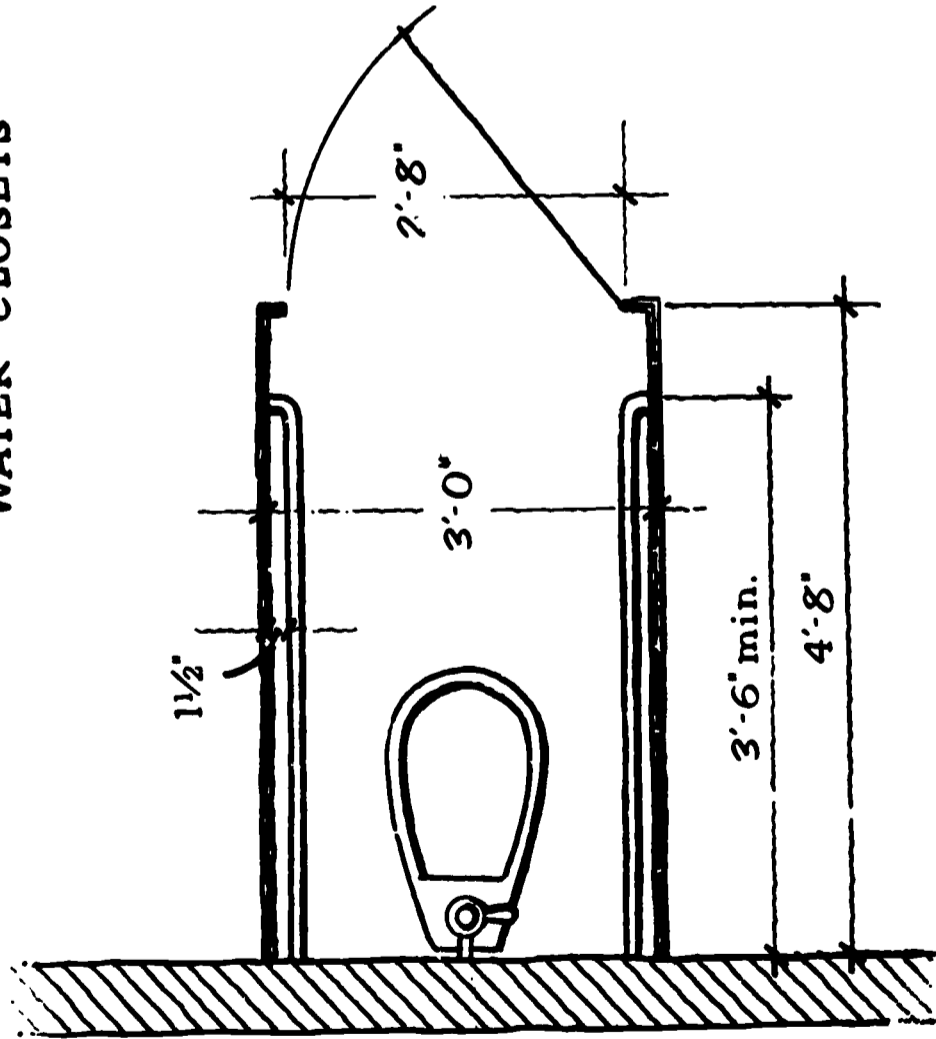

ROOM IDENTIFICATION SIGNS

