

ED 022 337

By-erran, Archie L.

PLANNING THE SCHOOL FOOD SERVICE FACILITIES. REVISED 1967.

Utah State Board of Education, Salt Lake City.

Pub Date 67

Note- 75p.

EDRS Price MF-\$0.50 HC-\$3.08

Descriptors- BIBLIOGRAPHIES, \*DESIGN NEEDS, DINING FACILITIES, EQUIPMENT MAINTENANCE, \*EQUIPMENT STANDARDS, FACILITY GUIDELINES, \*FOOD HANDLING FACILITIES, \*FOOD SERVICE, \*PUBLIC SCHOOLS, SPACE UTILIZATION

Evaluations of food service equipment, kitchen design and food service facilities are comprehensively reviewed for those concerned with the planning and equipping of new school lunchrooms or the remodeling of existing facilities. Information is presented in the form of general guides adaptable to specific local situations and needs, and is provided for location space, construction features, and equipment. For each food service area equipment needs are listed for serving a range from 100-750 diners per meal. Included is a glossary of engineering and architectural symbols and abbreviations plus scaled templates of food service equipment for food service area layouts, and a bibliography. (NI)

# SCHOOL PLANT PLANNING SERIES

## THE PLANNING OF SCHOOL FOOD SERVICE FACILITIES

UTAH STATE BOARD OF EDUCATION  
 DIVISION OF SCHOOL FOOD SERVICES  
 1400 UNIVERSITY CLUB BUILDING  
 SALT LAKE CITY, UTAH 84111

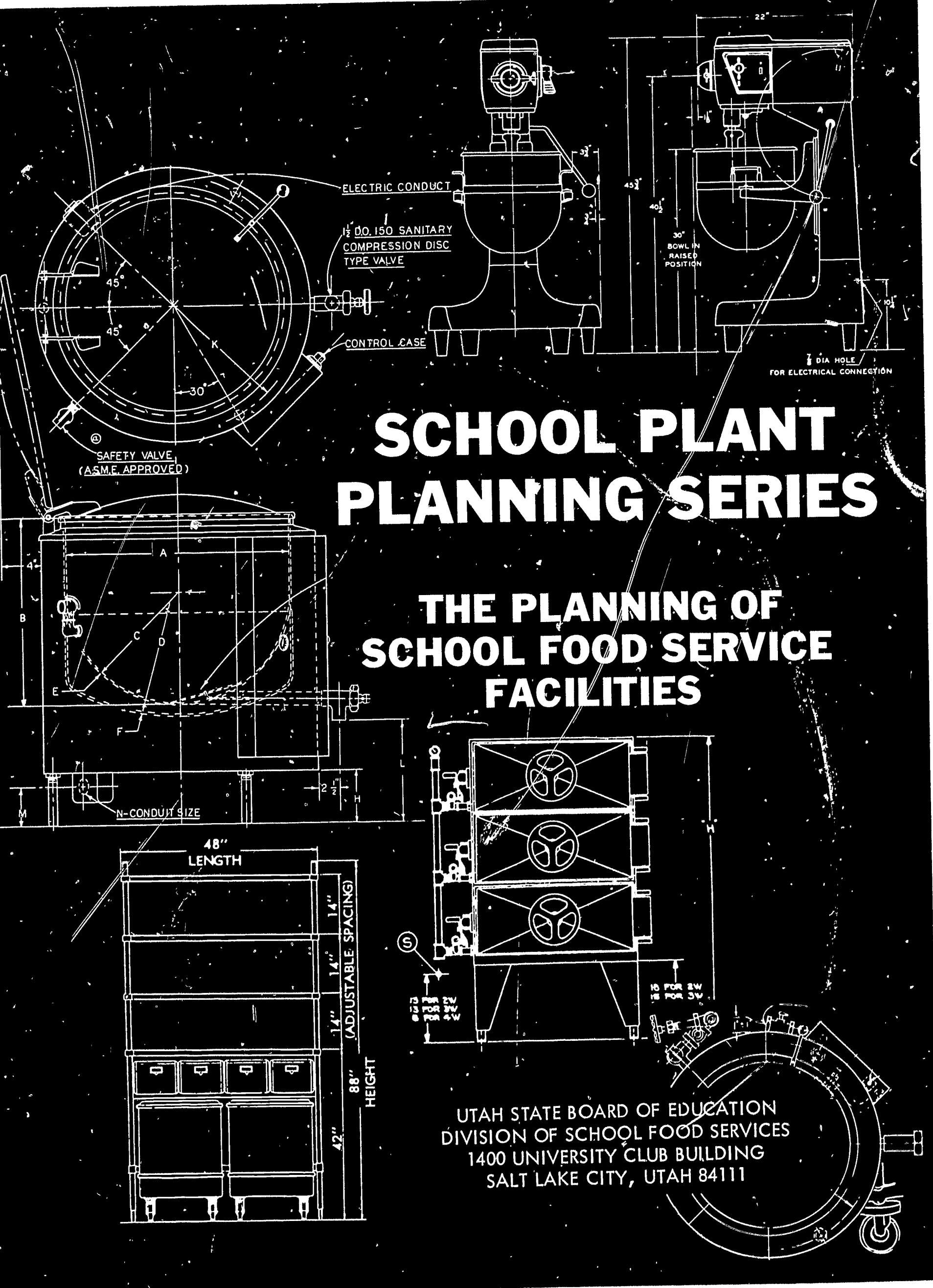

SCHOOL PLANT PLANNING SERIES

PLANNING THE SCHOOL FOOD SERVICE FACILITIES

U.S. DEPARTMENT OF HEALTH, EDUCATION & WELFARE  
OFFICE OF EDUCATION

THIS DOCUMENT HAS BEEN REPRODUCED EXACTLY AS RECEIVED FROM THE  
PERSON OR ORGANIZATION ORIGINATING IT. POINTS OF VIEW OR OPINIONS  
STATED DO NOT NECESSARILY REPRESENT OFFICIAL OFFICE OF EDUCATION  
POSITION OR POLICY.

UTAH STATE BOARD OF EDUCATION  
1400 University Club Building  
Salt Lake City, Utah 84111

T. H. Bell, Superintendent

DIVISION OF SCHOOL FOOD SERVICES

1 9 6 7

## TABLE OF CONTENTS

	Page
Foreword . . . . .	2
Preface . . . . .	3
A Guide For Planning and Equipping School Lunchrooms . . . . .	4-6
Concept of Flow . . . . .	7
Receiving Area . . . . .	8-11
Dry Food Storage Area . . . . .	12-14
Nonfood Storage Area . . . . .	15-16
Maintenance Area . . . . .	17-20
Office Area . . . . .	21-22
Locker and Toilet Area For Employees . . . . .	23-25
Kitchen Area . . . . .	26-29
What To Consider Before You Buy Commercial Cooking Equipment . . . . .	30
Cooking and Baking Equipment . . . . .	31
Ranges . . . . .	31-32
Ovens . . . . .	32
Convection Ovens . . . . .	32-33
Steam Equipment . . . . .	33
Steam Jacketed Kettle . . . . .	34
Compartment Steamer . . . . .	35
Deep Fat Fryer . . . . .	36
Hoods . . . . .	36-37
Mechanical Equipment . . . . .	37
Mixer . . . . .	37-38
Slicer . . . . .	38-39
Cutter or Chopper . . . . .	40
Peeler . . . . .	40
Refrigeration . . . . .	41-42
Sinks . . . . .	42-43
Tables . . . . .	43-44
Racks . . . . .	45
Other . . . . .	45
Mobile Equipment . . . . .	46
Small Equipment . . . . .	47-52
Serving Area . . . . .	53-57
Dish Return and Dishwashing Area . . . . .	58
Dishwashing Machine . . . . .	60-62
Dining Area . . . . .	63-66
Preventive Maintenance of Food Service Equipment . . . . .	67
Summary of Space Recommendations for School Lunchroom Areas . . . . .	68
Engineering Abbreviations and Architectural Symbols . . . . .	
Scale Templates . . . . .	
Bibliography . . . . .	

## FOREWORD

The basic and elemental aim of school food service is to provide nutritionally adequate, attractive, low-cost lunches to all children under conditions and in a setting which furnishes valuable learning experiences.

School food service has become an integral part of the current educational program for two main reasons. First the role of nutrition in safeguarding and promoting the health and active energy of children is recognized. Understood, also is the further relationship between nutrition, health, and energy on the one hand and maximum participation in educational experiences on the other hand. The school lunch program helps to provide the child with the energies which carry him through the school day as an active participator and learner.

Second, there are potentially valuable learning and developmental experiences for the child inherent in the active participation in the school lunch program - - for example, education and good food habits, dining room etiquette, consideration for others, and sensitivity to the needs and feelings of others in an intimate setting. A rare opportunity is afforded for basic social education. Further, the lunchroom presents opportunities for education in and about food, its economies, production, distribution, consumption, inter-activities of food and people locally, nationally and worldwide.

Thus a well organized and properly conducted school lunch program, suitably housed and equipped, requires the same care in planning, selection and placement of equipment as other education centers. The location of this facility in relation to other departments may well determine the benefits of the program as an education service.

-- Rodney A. Ashby, Administrator

## PREFACE

This publication is designed to serve as a guide for Utah School Food Services and others concerned with the planning and equipping of new school lunchrooms or the remodeling of existing facilities.

Adequate facilities are essential to the operation of a good school lunch program. With new construction rapidly expanding and new trends in designing education for the future affecting this program, an urgent need was felt to bring together in practical and usable form, the best and most current information available on efficient school lunch facilities and equipment.

This manual presents information in the form of general guides capable of being adapted to specific local situations and needs. It provides information on location, space, construction features and equipment for all lunchroom areas and is based upon the service of lunches meeting the Type A standard.

For each lunchroom area, equipment needs are listed for four different meal loads, ranging from 100 to 750 lunches per day. Lunchrooms serving fewer than 100 or more than 750 lunches daily present specialized problems that are beyond the scope of this publication, although the same basic principles should be applied. For the same reason, the design of central food preparation facilities is not considered in this guide.

For many areas of school lunch equipment and facilities, there is no commonly accepted standard of minimum essential needs. Needs may differ by grade level. The guides recommended in this publication are a consensus. Equipment recommendations have been checked against the quantities of food required to prepare Type A lunches, allowing a margin for needed variety in menu planning. Area and space recommendations have been checked to insure that they permit efficient arrangement of recommended essential equipment.

The materials included in this publication have been drawn from many sources, and 1967 Utah State University Workshop sessions on equipment. We wish to acknowledge the extent and importance of all contributions.



# A GUIDE FOR PLANNING AND EQUIPPING SCHOOL LUNCHROOMS

## BASIC PRINCIPLES

### IMPORTANCE OF GOOD PLANNING

The National School Lunch Program is designed to improve the health of school children and to broaden food markets by assisting districts to expand and improve the service of well-balanced lunches at school. Good planning and equipping of school lunchrooms is essential to attaining these objectives.

With many schools improving their school lunch facilities and many more schools being built, proper planning and equipping is a matter of concern to many. The complexity of building construction, the technical details of specifications and contractual procedures require competent professional assistance. The combined efforts of architects, consulting engineers, equipment specialists, sanitarians, and the State and local school lunch supervisory staff should assure a school lunch facility that will be useful for many years.

### POINTS TO CONSIDER

Space requirements: When considering the number of meals a kitchen facility will be expected to provide, planners should keep in mind the basic objectives of the school lunch program. The express intent of the program is to provide students with nutritious and well-balanced meals and to make lunch at school an educational experience. Therefore, physical efficiency and budgeting are not the only factors to be considered.

One of the most widespread defects of school lunch facilities is that they are too small for the number of students to be served. This stems from budget limitations, and too low an assessment of the growth trends in school enrollment, which lead to construction of kitchen facilities that do not provide for growth.

Experience has shown that it is feasible, in spite of the usual budget limitations, to plan kitchen storage and lunchroom facilities that could handle a 50 per cent increase in the number of meals served. Thus, in communities where school enrollment trends forecast a marked increase in the use of facilities, planning should provide for expected growth in the next 5 to 10 years.

Another factor influencing the size of facilities is the student participation in the lunch program. This is governed by the type of lunch program offered, the variety and appeal of menus served, alternative eating opportunities available to students, and practices in the scheduling of lunch periods. In many schools, average daily participation of students is less than 50 per cent of enrollment. In other schools with favorable circumstances, as high as 90 per cent participation has been attained.

There are other trends in public school administration that will influence lunch program participation by pupils. Increasing pressure upon school facilities requires closer scheduling in the use of facilities and available teachers. More schools are likely to require students to remain at the school dur-

ing the lunch period and more staggered lunch periods are likely to be used. These developments will tend to channel upper grade students who presently leave the school grounds during the lunch period into the lunchroom serving lines. But it will also call for an increased variety in menus and at least a limited choice among food items.

Allow ample space to provide for a high percentage of school lunch participation by the student body and for expansion of the school building. If the lunchroom is to be used for adult group meetings and other school-community activities, allow space for accessory items that may be needed.

Adequacy of space will influence operating costs of a school lunch facility as well as initial building cost. When space is too small, labor time and effort will increase. On the other hand, when the facility is too large, walking distances between work stations are unnecessarily long, and building and maintenance costs are excessive. With only a few exceptions, however, the tendency in the past has been to allow too little rather than too much space.

Classification of school: Consider what age groups will be attending school; elementary, junior high, senior high, or a combination of two or all grade levels of school children.

Correlation of the school plant: The pattern of the entire school building determines the location and best arrangement of the school lunchroom.

Location: The convenience of school food service facilities is in part determined by their location.

1. The lunchroom unit should be on the first floor with the kitchen accessible to the service driveway.
2. The dining room should have convenient entrances from the building and from the exterior.
3. If the lunch facilities are in a separate building, covered passages with paved walks should be provided.
4. The exterior entrance should also be accessible to the public, independent of other school facilities.
5. Delivery entrance and exits should be located away from playground areas and student traffic lanes.
6. Location should provide plenty of light, air and space free from disagreeable odors, noxious fumes and noise. (away from incinerator).

School's administrative policy: The capacity of the dining room depends upon the length of the serving period. If school policy limits the lunch period to a short time, then more dining space and serving equipment are required than if the lunch is served to groups coming at different intervals, thus permitting the re-use of seating space and longer use of serving equipment. Trend toward flexible scheduling of curriculum will offset regimented lunch time. Food service will be continuous for two hours or for the time necessary.



Availability of utilities and services: Determine whether public utilities--gas, electricity, water, and sewers--are available, or whether private utilities are necessary. Consider location--rural or urban--and whether the school gets quick, frequent deliveries of supplies and services, or is located away from such facilities.

Selection of school lunch facilities: Select each feature of the school lunchroom on its own merit for school food service, not because of its use in commercial restaurants or other public institutions. Equipment suitable for one unit does not necessarily apply to another. Stock kitchen plans are not flexible enough to fit over-all school plans. Each school lunch program is an individual program and the information given in this manual should be adapted to your local situation.

Durability of materials: To get maximum returns for money expended, the school lunchroom should be planned to be useful without major remodeling for many years. It should be functional and durable, and should not require major repairs or replacement expenses.

Sanitation: Lunchroom construction and equipment should be sanitary and easy to keep clean, not harboring rodents, vermin, or infection. Equipment should include sanitizing devices for washing and sanitizing all dinnerware and utensils. Sanitary storage facilities for dry foods and perishable products are also essential.

Environment: Consider cleanliness, good lighting, cheerful colors, good ventilation, and noise control. Consider also the possibility of connecting the inter-communication system of the school with the lunchroom and of providing space for bulletin boards and educational exhibits. These all lend attractiveness to the school lunchroom and develop pride of the employees, students, and community in their school lunchroom.

#### IN SUMMARY

#### MAIN POINTS IN PLANNING FOR FOOD SERVICES

The main points in planning for the food service in an institution or in industry are:

1. Plan well in advance
2. Utilize competent counsel
3. Determine optimum location
4. Allow adequate space for present and future needs
5. Arrange layout for efficient production and distribution
6. Select well-engineered and durable equipment
7. Design for easy cleaning and sanitation

CONCEPT OF FLOW

The flow concept is a basic principle in planning food service facilities and can be used either to develop the layout or to evaluate the intuitive layout. Determining the flow establishes the relation of the various areas to one another as far as material movement is concerned. The overall integration of areas in a food service facility is a must.

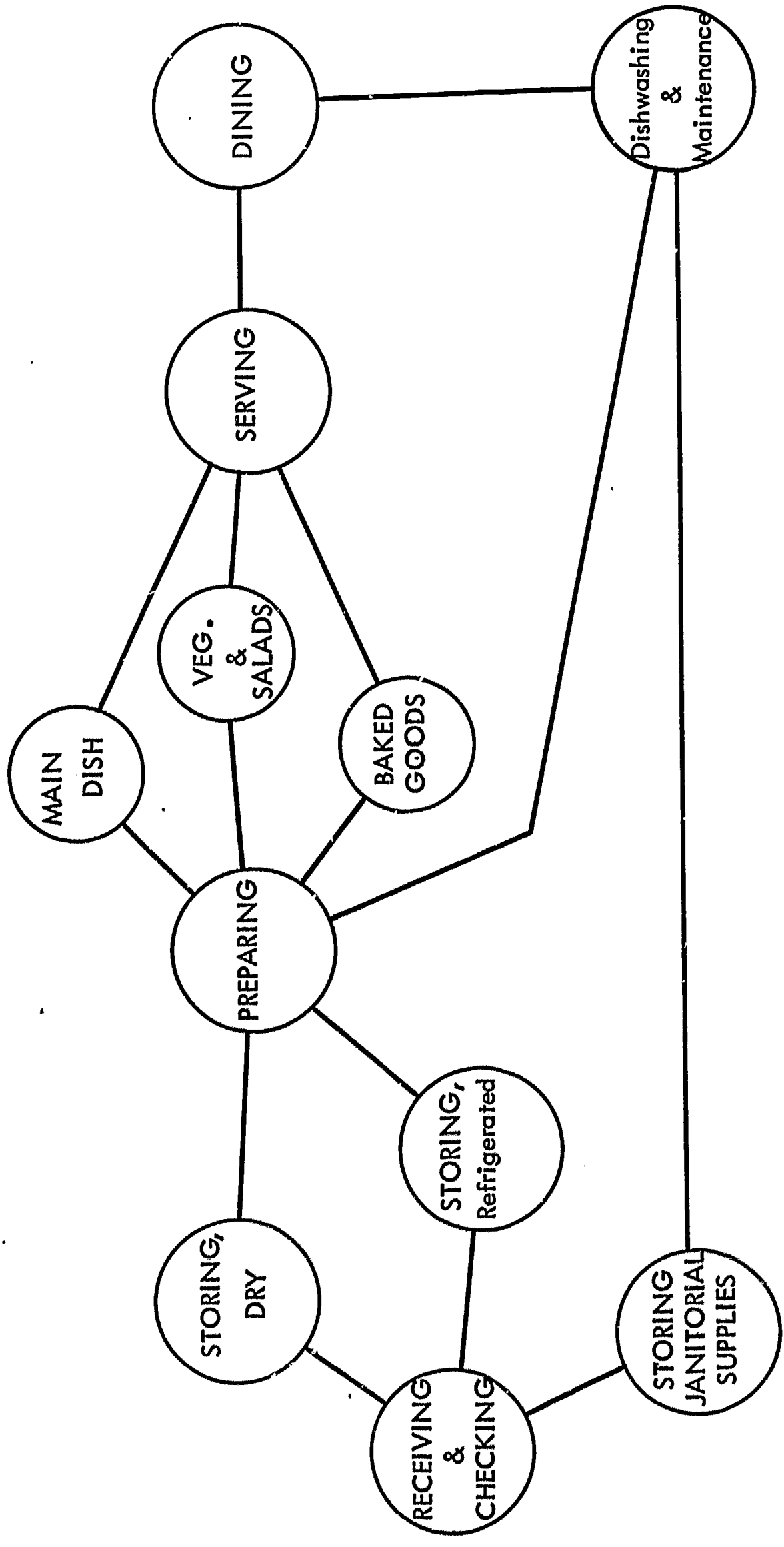

### RECEIVING AREA

- PURPOSE:** An outside loading platform and a receiving area inside the building are needed:
- To facilitate handling of food and to protect it from the elements.
  - To provide temporary storage until deliveries are checked for quality weight and count.
  - To facilitate disposal of trash and garbage.

### OUTSIDE LOADING PLATFORM

- LOCATION:** On ground floor level, near service driveway, adjacent to storeroom and kitchen, away from playgrounds and student traffic.
- SPACE:** Will depend on delivery service, volume of deliveries, etc. For width, allow at least six feet from front to back.

### TOTAL LUNCHESES SERVED DAILY

100 - 200	200 - 350	350 - 500	500 - 750
60 sq. ft.	60 sq. ft.	80 - 100 sq. ft.	100 - 160 sq. ft.

Garbage or trash storage: Near the loading platform should also be provided a garbage room and a room for the storage of trash. These rooms should be well screened, and it is desirable that the garbage room be refrigerated. However, if a garbage disposer connected with a sewage system is used, only the dry garbage storage area will be needed.

Trend is toward use of can and bottle crushers to reduce bulk dry garbage. (optional)

### CONSTRUCTION FEATURES:

Consult State and local authorities having jurisdiction over applicable regulations.

Floor: Concrete with integral hardener, slip resistant. Heavy steel angle iron to reinforce edge; wood bumper optional. At same level as entrance to inside receiving area; avoid ramp or steps from platform into building. Truck bed height. Proper drainage essential.

Lighting and wiring: Comply with National Electric Code requirements (an American Standard) together with other local requirements. Minimum, 150 to 200-watt lighting unit; weather-proof type if platform is unprotected.

Other considerations: Roof extending over entire platform is desirable, must be high enough to clear any delivery truck, generally 12 ft. 6 in. to 13 ft. Steps with hand rail from platform to driveway level.

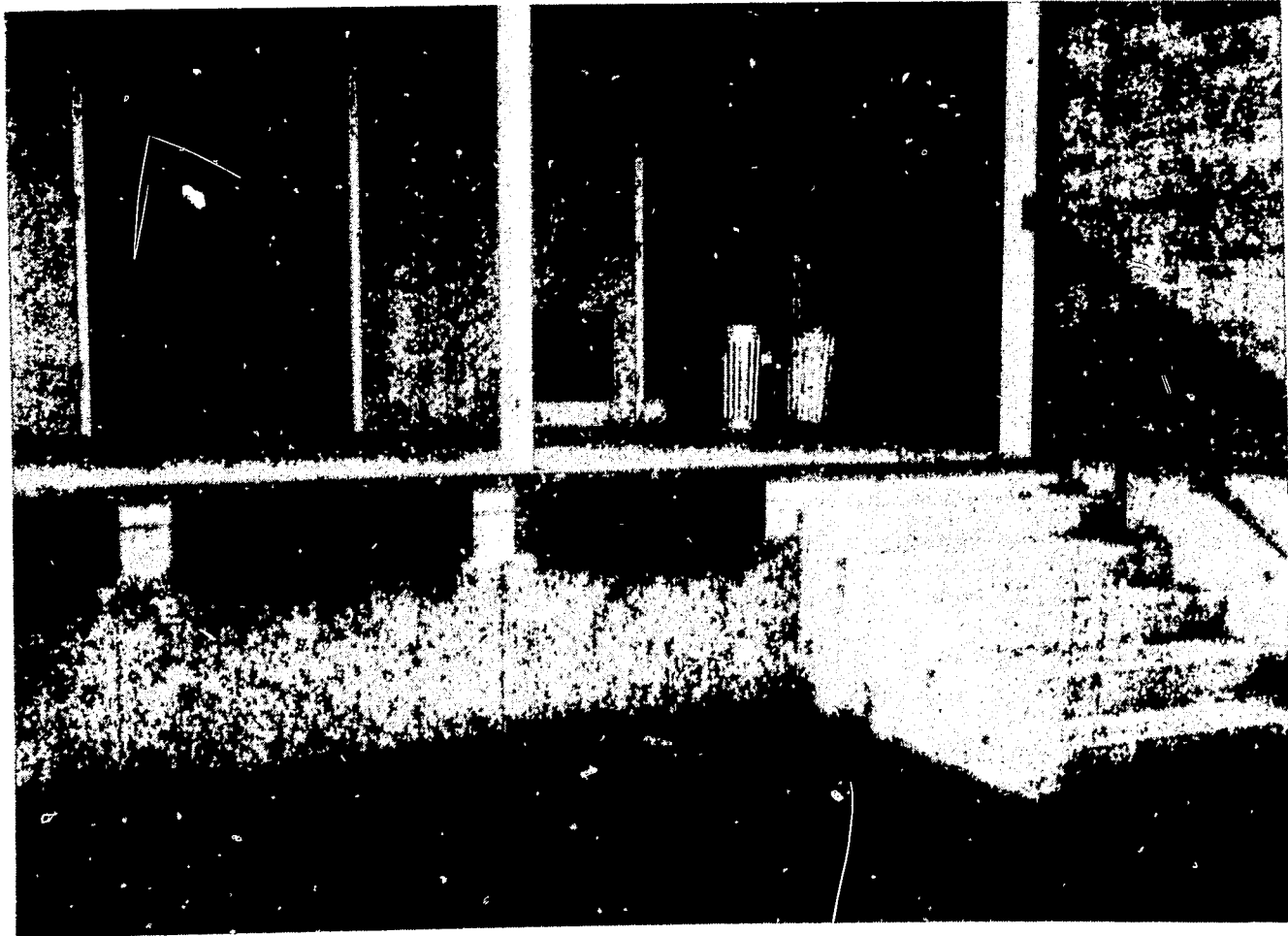

View of receiving area showing outside loading dock.

#### RECEIVING AREA INSIDE BUILDING

- LOCATION: Adjoining loading platform, separate from kitchen and store-room, if possible. May serve as vestibule.
- SPACE: Will vary depending on frequency and volume of deliveries, and time required for checking and storage. Net usable space, exclusive of traffic aisles.

TOTAL LUNCHESES SERVED DAILY

100 - 200	200 - 350	350 - 500	500 - 750
32 - 48 sq. ft.	48 - 60 sq. ft.	48 - 60 sq. ft.	60 - 80 sq. ft.

CONSTRUCTION FEATURES:

Consult State and local authorities having jurisdiction over applicable regulations.

Floor: Slip-resistant; terrazzo, quarry tile, or concrete with integral hardener. Check local regulations regarding floor drains.

Walls and ceiling: Light in color, smooth, impervious to moisture, easy to wash and keep in good repair. Glazed tile most desirable; painted plaster or masonry acceptable; plaster-board or wood not desirable because not vermin-proof; coved bases at floor line. Local regulations may require coved vertical corners.

Doors: Heavy duty doors between outside loading platform and receiving area inside building. Clear opening, minimum 3 ft. 4 in. wide. Self-closing and locking devices. Kick-plate on both sides of door at least 6 in. high.

Windows: Need determined by state and local regulations. If provided, avoid interference with equipment.

Lighting and wiring: Comply with National Electrical Code requirements (an American Standard) together with other local requirements. Minimum 15 ft. -candles normally achieved by about 2 watts per square foot of floor area.

Other considerations: Check regulations regarding fly and pest control, i. e., screened doors, blow-down fans, etc.

EQUIPMENT:

Clip board for checking in supplies.

Scales: Portable floor model, automatic indicating and beam-types available; minimum 400 lb. capacity;  $\frac{1}{4}$  to  $\frac{1}{2}$  lbs. graduations.

Table: Heavy metal frame; on casters; top of metal of dense-grained hardwood a minimum of  $1\frac{1}{4}$  in. thick; work drawer.



Hand truck: Frame, approximately 48 in. high; at least 14 in. wide; bottom angle nose at least 14 in. by 7 in.; rubber-tired wheels; curved brace bars for handling round containers; glides for going up and down steps; handles and brakes.

Platform truck: Heavy-duty; metal frame; platform of wood or metal; rubber-tired ball-bearing wheels; 2 swivel and 2 rigid forks; rubber bumpers; handle on swivel end.

## DRY FOOD STORAGE AREA

**PURPOSE:** To provide security and orderly storage of food not requiring refrigeration; to protect foodstuffs against spoilage or contamination by moisture, rodents, vermin, or heat.

**LOCATION:** Adjacent to kitchen area; convenient to receiving area - for efficiency of operation all storage spaces with the exception of space for root vegetables, and fruit, should be on the same floor level as the kitchen. Basement storage even with dumb waiters is costly to operate in terms of man-hours of labor.

Area to be free of uninsulated pipes, water heaters, refrigeration condensing units or other heat-producing devices.

**SPACE:** There is a tendency to under-estimate the need for storage space in school food service operations. To date there are no provisions for state storage and in many school districts no provisions for district storage. For this reason it is emphasized that schools plan for adequate dry storage taking into consideration growth of school enrollment and program participation. The USDA recommended figure of .05 sq. ft. of floor space per meal served daily is based upon a two weeks' supply of staples and is not adequate for school lunch operations in Utah. Storage space requirement should be based on district policy. If the school is part of a large system with a central commissary used for the storage of staples and USDA commodities, area requirements depend on frequency of deliveries from this central source. If the school purchases large quantities of staples at one time or must provide storage area for large quantities of USDA commodities, the additional space is necessary. (adequate storage is a governing factor in efficient unit operation.

### CONSTRUCTION FEATURES:

Consult State and local authorities having jurisdiction over applicable regulations.

Floor: Slip resistant; terrazzo, quarry tile, or concrete with integral hardener. Check local regulations regarding floor drains.

Walls and ceiling: Light in color, smooth, impervious to moisture, easy to wash and keep in good repair, glazed tile most desirable; painted plaster or masonry satisfactory, plasterboard or wood not desirable because not vermin-proof; coved bases at floor line. Local regulations may require coved vertical corners.

Doors: At least 40 in. wide, heavy-duty locking from outside but always opening from inside without key. Consider advisability of having one door to kitchen area and one door to receiving area.

Windows: Need determined by State and local regulations. If provided, avoid interference with shelving; consider security type sash.

Lighting and wiring: Comply with National Electrical Code requirements (an American Standard) together with other local requirements. Approximately 15 foot-candles; normally achieved by about 2 watts per sq. ft. of floor area. Check plan for storage shelving. Locate lighting fixtures over aisles.

Ventilation: Must be adequate to remove all offensive or dangerous fumes, gases, mists or odors and to prevent condensation on walls, ceiling, equipment and food. Generally four changes per hour is adequate. Keep area free from heat-producing devices. Room temperature best for dry storage from 40° F. to 70° F. Insulate exterior walls; vapor-seal walls and floors below ground level. Positive mechanical ventilation with automatic temperature control and louvered, screened vents to outdoors, for continuous day and night operation, or natural ventilation through screened security sash or louvered screened vents to outdoors.

Other considerations: Avoid exposed conduits, pipes, other surfaces difficult to keep dust-free.

#### EQUIPMENT:

Shelving: Wood or metal, supported by uprights, not more than 48 in. apart, 7 ft. 6 in. maximum practical height; 1 in. vertical adjustment of shelf supports convenient for arranging shelving to accommodate inventory. Allow 1 in. minimum clearance from all walls for cleaning and air circulation. Brace well against tipping. Standard shelving available, 12 in., 13 in., or 24 in. deep. Provide 36 in. vertical clearance under shelving where portable platforms, cans, and dollies may be located. Aisle space, 30 in. minimum for access to shelving only; 42 in. minimum for movement of portable platforms.

Adjustable shelves provided for broken case lots and pallets (dunnage platforms) for case quantities.

A substantial portion of the storage room should be left free of shelves in order to provide dunnage platforms in sections sized for adequate storage and sized for convenient movement. (on casters). The dunnage should be so designed that there is free movement of air underneath. It saves labor to use canned goods directly from the cases in which they are received.

Current trends are mobilized, adjustable metal shelves. They are very versatile and may be used in other areas, refrigerated or work, when not needed in dry storage area.

Portable platforms: (Dollies, pallets, skids). In small sections approximately 24 in. by 36 in.; constructed of heavy-gage steel tubing or wood slats; caster mounting desirable. To be used under bottom shelf or in center of room if space is sufficient.

Floor storage container: (50 or 100 lb. size). Available aluminum, stainless steel, or galvanized iron, with vermin-tight covers; coved corners desirable. Available with or without casters or may be used on dollies.

Grocers' scoops: Corrosion-resistant material; 1 to 1½ lb. capacity.

Thermometers, wall type: Temperature range, minus 20° F. to plus 120° F. in 2° scale divisions; 12 in. minimum overall length.

Hand truck: Frame approximately 48 in. high; at least 14 in. wide; bottom angle nose at least 14 in. by 7 in.; rubber-tired wheels. Optional features, curved brace bars for handling round containers; glides for going up and down steps; handles, brakes. Truck may also be used in the Receiving Area. Bumpers optional.

Casters for mobile equipment: Stationary, swivel, locking, ball bearing swivel axle, brake type, stem and plate construction, caster sized to each piece of equipment, taking into account such requirements as load capacities, overall height and transportation involved; rubber-tired, special casters to meet specific requirements can be purchased. Generally, no caster smaller than 5 in. should be used in food services. Casters capable of static load, minimum of 250 lbs. per caster. Lifetime lubrication. Bumpers optional. (See Mobile Equipment).

#### CAN AND CARTON MEASUREMENTS FOR ESTIMATING SHELF CAPACITY

Size Can	Approx. Diameter of Can Inches	Clear Height Per Tier Inches	Cans Per Carton Number	Size of Carton Inches
No. 10	6¼	7½	6	19 x 12 ¾ x 7 ¾
No. 2	3½	5	24	14½ x 10 ¾ x 10
No. 2½	4	5	24	17 x 12 ¾ x 10¼
No. 3 (Cylinder)	4¼	7½	12	17½ x 13½ x 7 ¾

## NONFOOD STORAGE AREA

**PURPOSE:** From a safety and sanitation standpoint it is important to provide a separate storeroom for nonfood items such as soaps, detergents, wetting agents, other cleaning supplies, and paper goods separate from foods and school janitorial supplies. Separate storage of such items needed to prevent absorption of chemical odors by food and to facilitate inventory control.

**LOCATION:** Adjacent to receiving area. Convenient to kitchen, dishwashing and maintenance.

**SPACE:** TOTAL LUNCHESES SERVED DAILY

100 - 200	200 - 350	350 - 500	500 - 750
15 - 24 sq. ft.	30 - 40 sq. ft.	40 - 60 sq. ft.	60 - 80 sq. ft.

Note: These figures do not provide space for washer-dryer.

### CONSTRUCTION FEATURES:

Consult State and local authorities having jurisdiction over applicable regulations.

Floor: Slip-resistant; terrazzo; quarry tile or concrete with integral hardener.

Lighting and wiring: Comply with National Electrical Code requirements (an American Standard) together with other local requirements. Approximately 15 foot-candles; normally achieved by about 2 watts per sq. ft. of floor area.

Ventilation: Natural or mechanical to provide four air changes per hour, 24 hour basis in larger schools.

Other considerations: Check district policy regarding laundry service. If commercial laundry service is not the policy then space must be provided for a washer-dryer. This is the most likely area for the location and operation of this equipment and space must be planned in addition to the suggested guide for nonfood storage areas.

Vermin and rodent-proof. If area contains pipes, panel boards, water tanks, etc., avoid interference with storage area.

**EQUIPMENT:** Cabinet: Metal or wood; 36 in. by 24 in. by 72 in. high; locker type; fixed bottom, 4 intermediate shelves; hinged doors.



Shelving: Wood or metal; supported by upright, not more than 48 in. apart; 7 ft. 6 in. maximum practical height; 1 in. vertical adjustment convenient for arranging shelving to accommodate inventory 1 in. minimum clearance from all walls for air circulation; brace well against tipping. Standard shelving available. Portable metal shelving recommended.

### MAINTENANCE AREA

**PURPOSE:** To provide convenient facilities for garbage, trash and house keeping equipment.

**LOCATION:** Near service entrance. Garbage and trash areas opening on to loading platform, convenient to kitchen and dishwashing areas. Mop area opening into receiving area inside building. Separate rooms desirable for each function.

#### TOTAL LUNCHES SERVED DAILY

100 - 200	200 - 350	350 - 500	500 - 750
30 - 48 sq. ft.	30 - 48 sq. ft.	48 - 60 sq. ft.	60 - 75 sq. ft.

Trash area: Separate room desirable for temporary storage of empty crates, cans, and waste goods. Reduce space if incinerator is used.

#### TOTAL LUNCHES SERVED DAILY

100 - 200	200 - 350	350 - 500	500 - 750
May use garbage area		20 - 30 sq. ft.	30 - 40 sq. ft.

Mop area: Separate room desirable.

#### TOTAL LUNCHES SERVED DAILY

100 - 200	200 - 350	350 - 500	500 - 750
24 sq. ft.	24 sq. ft.	30 - 40 sq. ft.	30 - 40 sq. ft.

**CONSTRUCTION FEATURES:**

Consult State and local authorities having jurisdiction over applicable regulations.

Floor: Slip-resistant; concrete with integral hardener or quarry tile. Floor pitched to drain.

Walls and ceiling: If separate room, use same finish as dishwashing area.

Doors: Provide durable, reinforced, tight-fitting screened doors, minimum 3 ft. wide; opening outward with self-closing devices. Kick plates on both sides of door, at least 6 in. high.

Lighting and wiring: Comply with National Electrical Code requirements (an American Standard) together with other local requirements. Minimum 10 foot-candles; normally achieved by about 1 watt per sq. ft. of floor area. Lighting fixtures of weatherproof type desirable.

Plumbing: Cold and hot water outlets and hose connection for garbage area; faucets high enough to clear cans. Drain connections and spray nozzle for can washing in garbage area.

Ventilation: If an enclosed room is used, provide screened grills or windows; exhaust fan desirable for garbage room.

Other considerations: Consult local authorities regarding fly and pest control, i.e. screened doors, refrigeration for garbage area, blowdown fans, etc.

**EQUIPMENT:**

Garbage and trash areas: Garbage cans and covers; galvanized; 15 to 20 gallons, available with or without casters or may be used on dollies. Number depends on method of disposal. Use of food waste disposer and incinerator reduces number needed.

Racks, broom and mop: Stationary types. Number depends on local needs.

Shelves in trash area; preferably metal; slatted; approximately 18 in. wide for temporary storage of baskets, crates, etc. Number depends on local need.

Mop area: Brooms: Push broom; approximately 14, 16 or 18 in. in width; long handle. Upright broom, natural fiber; heavy-duty; long handle. Number of brooms dependent upon district policy regarding janitorial services.

Brushes: Scrub brush (deck); heavy-duty; approximately 10 by 3 in.

Buckets: Scrub bucket; galvanized; bale handle.

Mop bucket: Double tank; galvanized; on casters; 16 to 44 qt. capacity; squeeze-type detachable wringer desirable. (Needed if floor scrubbing and polishing machine is not available.)

Dust pans: Heavy-duty; 12 to 16 in. pan.

Floor scrubbing and polishing machine: Heavy-duty; electric; concentrated weight; 12 to 15 in; vacuum pickup type convenient. Use machine provided for other areas of building.

Mops: Dust mop: Treated; heavy-duty; 16 to 24 in. Optional.  
 Wet mop: Heavy-duty; string or sponge; detachable handle.  
 Optional. Extra mop-heads as needed.

Racks, broom and mop: Stationary type.

Shelves: Preferably metal; adjustable; for cleaning supplies  
 and tools.

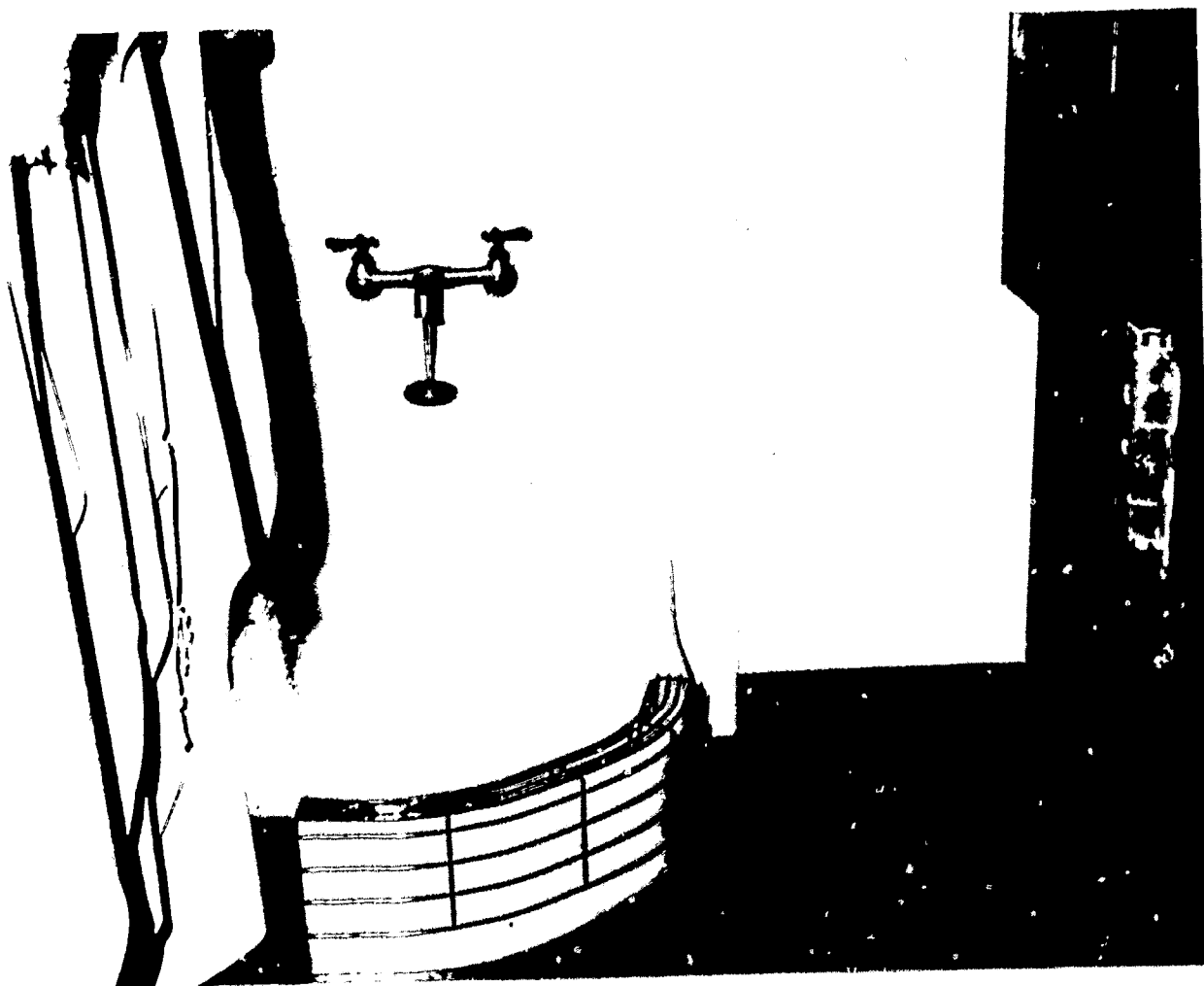

View of mop and nonfood storage area.

TOTAL LUNCHESES SERVED DAILY  
 Shelf Area

100 - 200	200 - 350	350 - 500	500 - 750
12 sq. ft.	12 sq. ft.	18 sq. ft.	24 sq. ft.

Equipment in mop area:

Sinks: Mop sink; stainless steel, acid resistant porcelain  
 enamel on cast iron, or vitreous china; approximately 22 by 20  
 in. by 14 or 16 in. deep, inside measurements; front rim  
 approximately 30 in. high; mixing faucet with bale support;  
 trap.

Stool: With folding stepladder: Metal or wood; safety- type  
approximately 14 in. high.

Tool kit: Claw hammer, plier with wire cutter, screw driver,  
and crate or carton opener.



OFFICE AREA

PURPOSE: For good program management it is important to provide office space for planning menus, preparing market orders, making work schedules, keeping inventories and other school lunch records; and for conducting conferences with employees.

LOCATION: Adjoining or near kitchen, easily accessible to delivery entrance. Separate room desirable.

SPACE: TOTAL LUNCHESES SERVED DAILY

100 - 200	200 - 350	350 - 500	500 - 750
48 - 60 sq. ft.	48 - 60 sq. ft.	48 - 60 sq. ft.	48 - 60 sq. ft.

CONSTRUCTION FEATURES:

Consult State and local authorities having jurisdiction over applicable regulations.

Lighting and wiring: Comply with National Electrical Code requirements (an American Standard) together with other local requirements. Approximately 50 foot-candles; normally achieved by about 5 watts per sq. ft. of floor area.

Other considerations: Provide same general features of construction as other areas. (Kitchen)

Sectional office partitions with upper clear glass panels are desirable. This will give an impression of greater spaciousness and allow manager supervision of receiving and food preparation areas.

If jobs of the lunchroom manager, her assistant and/or head cook are filled by different persons, additional office space should be provided as needed. Approximately 120 sq. ft.

Ventilation: Ventilation will be of special concern in an area this small. Natural or mechanical to be provided.

EQUIPMENT: Desk, standard: Approximately 54 in. with pedestal base; may accommodate typewriter or adding machine, recipe card file; file drawers.

Desk light

Chairs as needed

Telephone: Extension as required for convenience.

File cabinet: legal size; 3 or 4 drawers or may use desk drawer.

File box: (Preferably drawer) For 5 in. by 8 in. recipe cards.  
First aid kit, as required by State Health Department, and  
school accreditation outline.  
Typewriter: Table with drawer; and chair. (optional)  
Adding machine: (optional)  
Purse lockers or cabinet: (optional)  
Waste basket: As needed.



View of office area adjacent to delivery and kitchen. Clear glass panels provide partitions. Sufficient space has been planned for necessary office equipment as well as room for consultation purposes.

## LOCKER AND TOILET AREA FOR EMPLOYEES

**PURPOSE:** To provide facilities for lunchroom employees separated from other school facilities; to promote more rigid enforcement of State and local health regulations.

**LOCATION:** Near employees' entrance to kitchen area. Separate rooms for men and women if both sexes are employed.

**SPACE:** Toilet facilities space as required by State and local regulations. Locker room space approximately  $3\frac{1}{2}$  sq. ft. floor area per lunchroom employee. Allow an additional 20 sq. ft. if cot is used in womens' locker room.

### CONSTRUCTION FEATURES:

Consult State and local authorities having jurisdiction over applicable regulations.

Floor: Ceramic tile, terrazzo, quarry tile, or resilient tile; coved bases.

Walls and ceiling: Light in color, smooth, impervious to moisture, easy to wash and keep in good repair. Glazed tile most desirable; painted plaster or masonry acceptable. Plasterboard or wood surfaces most difficult to maintain.

Doors: Two with automatic closers; vestibule between toilet and kitchen areas (not required if opening onto corridor); consult local authorities. Locks limiting use to employees are suggested.

Windows: Required by many building codes for light and ventilation; mechanical ventilation and artificial lighting subject to State and local regulations.

Lighting and wiring: Comply with National Electrical Code requirements (an American Standard) together with other local requirements. Minimum 10 foot-candles; normally achieved by about 1 watt per sq. ft. of floor area.

Plumbing: Facilities for toilets as required by State and local regulations. Cold and hot water mixing faucets for lavatories.

Ventilation: Four air changes per hour desirable. Natural ventilation through outside window or vent; otherwise, exhaust fan desirable.

Other considerations: No uncleanable space beneath or behind lockers.



View of Rest Room Area  
Individual Lockers Shown At Right

**EQUIPMENT:**

Lockers: Metal; with locking device. Employees' possessions should be protected in a suitable safe and sanitary condition while employees are at work. Whether individual lockers or common cupboards, sufficient space should be allowed for personal clothing and uniforms to hang without crowding or wrinkling. Space to be provided for purses, parcels and other valuables.

Student help: Space and facilities should be provided for possessions of student help and correct storage of uniforms (aprons), caps, and/or hair nets.

Hand lavatory: Vitreous china, or acid-resisting porcelain enamel on cast iron; standard size; mixing faucet; stops and trap. Provide soap dispensers and towel dispensers or automatic hand dryers. (Consult local authorities regarding number required).

Toilet: To comply with State and local regulations consult authorities regarding number of required separate facilities provided for men and women. Toilet compartments measure approximately 3 by  $4\frac{1}{2}$  ft. to 5 ft.

Chairs or bench: In all cases benches or chairs are to be provided upon which workers may sit while changing clothes and shoes.

First aid cabinet: (May be in kitchen area or office)

Mirror: Approximately 18 by 24 in.

Cot or daybed: Size 36 in. by 6 ft. should be provided in the womens' room.

Showers: (Optional)



## KITCHEN AREA

**PURPOSE:** To provide a separate area for the preparation of school lunches and school breakfasts. In addition, for the receipt, care and dispensing of Special Milk.

In planning a kitchen, three steps are necessary:

1. Determine the cooking load
2. Decide on the equipment required
3. Lay out the equipment and facilities to afford maximum efficiency of operation

**LOCATION:** Adjacent to receiving, dining and serving areas. Easily accessible to food storage areas.

**SPACE:** The floor space needed for preparation and cooking of food is more subject to reduction in square footage required per meal than other areas. In small operations serving up to 200 meals a day, the 2 to 2.5 sq. ft. of kitchen floor area per meal served daily, is definitely necessary to provide adequate working space. Yet, with 350 to 500 meals a day, 1.5 sq. ft. per meal served daily was found to be sufficient. For more than 1,000 meals, 1 sq. ft. can prove quite adequate, and for as many as 2,000 meals per day, .08 sq. ft. of floor space per meal served daily will still permit a layout that allows the free flow of traffic.

Planning for expansion: In laying out the kitchen, thought should be given to the possibility of future expansion. Floor space and the necessary utility connections can be provided in the layout for additional pieces of equipment that may be required later. This foresight may save costly alterations at a later date.

Rectangular kitchen provides most efficient use of space, desirable for length to be not more than twice the width.

### CONSTRUCTION FEATURES:

Consult State and local authorities having jurisdiction over applicable regulations.

Floor: Nonresilient types: Slip-resistant; quarry tile, ceramic tile, or terrazzo; more durable than resilient types. Provide synthetic rubber or vinyl plastic mats at work centers. Resilient types: Slip-resistant; grease, acid, and alkali-resistant; vinyl asbestos or grease-proof asphalt or rubber tile. Fireproof slab under ranges and ovens. Provide floor bracing if needed. Solid base or island desirable for ranges; 1 in. to 5 in. high; coved at floor line. Drain recessed in floor away from work areas; pitch 1/8 in. per foot toward

drain, or floor may be level and pitched only for the width of one tile surrounding the drain. Floor areas under and surrounding steamers, kettles, and vegetable peelers should be surrounded by curbs or gutters and drained independently of other floor areas.

Walls: Light in color, smooth, impervious to moisture, easy to wash and keep in good repair. Glazed tile most desirable; to be non-light absorbent; painted plaster or masonry acceptable for areas not subject to splashing and daily washing; plasterboard or wood not desirable because not vermin-proof. Coved bases at floor line. Local regulations may require coved vertical corners. Metal corner guards preferably stainless steel, on all projecting corners subject to traffic damage. Soundproofing between kitchen, dining, and other school areas desirable.

Ceiling: Light in color, smooth, impervious to moisture, easy to wash and keep in good repair. Non-absorbent, rodent-proof, fire-resistant acoustical type desirable; mechanical suspension system less affected by steam and heat than adhesive attachment of acoustical materials. Painted, waterproof, mildew-resistant plaster or cement may be used.

Doors: If outside door, use self-closing devices and locks; metal frames desirable for outside and inside doors. Inside doors, soundproof, with locks. Wire-glass lookouts desirable. Doors leading from refrigerator or other self-contained rooms should have locks that can be opened from the inside. Kitchen area to have locks mastered to this area alone and not to the entire school.

Windows: Locate for cross ventilation. Low enough for good ventilation and light but high enough to permit alignment of equipment along outside walls, 48 in. sill height usually adequate. Provide good locks.

Some kitchens have been constructed with only a skylight or with no windows at all. If proper mechanical ventilation is provided, many workers will get accustomed to the situation. Other workers will feel unhappy in a room without windows. From a strictly functional viewpoint, there are no basic objections to a kitchen in the center of a building without windows.

Lighting and wiring: Comply with National Electrical Code requirements (an American Standard) together with other local requirements. Both natural and artificial lighting desirable. Avoid glare; employees should not work in own shadow. Windows preferable to skylight; if skylights used, heat-absorbing glass desirable. Artificial lighting, incandescent, fluorescent, or a combination of both. Fifty foot-candles on work

surfaces; normally achieved by about 5 watts per sq. ft. of floor area; approximately 20 to 30 foot-candles on other areas, normally achieved by about 3 watts per sq. ft. of floor area. Lighting fixtures recessed, surface-mounted or suspended type spaced for even distribution of lighting. Lighting circuit control panel board for all lunchroom areas and power circuit control panel board for kitchen area, readily accessible in kitchen area; flush mounting is desirable. Special wiring and outlets required for heavy-duty equipment. Determine voltage requirements of equipment to be installed and provide wiring and outlets accordingly. Provide spare circuits for future needs. Protect wiring against heat and grease. Locate one duplex outlet, (120-volt, single phase) 6 in. above working level approximately every 10 ft. Do not depend on these duplex outlets for operation of heavy-duty equipment.

Plumbing: Cold and hot water connections. Drainage and waste lines with accessible cleanouts. Grease traps, refrigerator drains, and other special connections according to local plumbing codes. Wherever possible, arrange piping to come out of walls instead of floor; at least 8 in. clearance for cleaning floor.



View of a kitchen area showing mobile cart, slicer, work table with an overhead pot and utensil rack, steam jacketed kettle, compartment steamer, convection oven, ventilating hood, stainless steel compartment sinks.

Heating: Automatic heating system same as rest of school, but with separate temperature control.

Ventilation: Mechanical ventilation separate from that of school system. Free circulation of air at workers' level. If natural ventilation, cross draft is desirable. Built-in vent or vented hood over range and other cooking equipment; approximately 100 cu. ft. exhaust ventilation per minute per sq. ft. of hood opening; filter intake in hood. Two-speed fans desirable. Minimum requirement, six air changes per hour. Supply air may be drawn from dining room or from outside through grill with automatic heating coil.

Other considerations: Select harmonious colors and materials for attractive appearance of room. Avoid exposed conduits, pipes, and other surfaces difficult to keep clean. Allow adequate space for cleaning all walls near fixed equipment. Desirable to have 18 in. clearance for cooking equipment; 12 in. clearance for tall equipment such as refrigerators; from 3 in. to 5 in. clearance for rims of work tables and sinks; 3 in. to 5 in. space between adjacent units of equipment. Consult local health authorities regarding clearance for equipment; vestibules for exterior doors; screen doors and windows, blow-down fans, and other means of fly and pest control.



## WHAT TO CONSIDER BEFORE YOU BUY COMMERCIAL COOKING EQUIPMENT

Whether you are selecting an individual piece of cooking equipment or choosing an entire complement of cooking units for a complete kitchen installation, you should heed certain caution signs and follow a number of guideposts.

Improper equipment selected unwisely, is a burden to smooth food preparation procedure and is a costly burden to management.

Good equipment wisely selected for specific cooking applications can help to upgrade your menu, speed your food preparation and reduce your operating costs.

Equipment purchased is cared for and used for a period of many years. It therefore is prudent to select the equipment which will serve you profitably rather than become a costly hindrance.

### Caution Signs

#### Beware of Claims

Do not be misled by sales presentations with claims of doubtful value that are unsupported by facts.

#### Don't Overlook Economic Factors

What are the costs? Equipment cost, installation cost, operating cost, service and maintenance cost.

Weigh fact against fancy.

#### Keep an Open Mind

Too much progress is being made today in improving equipment performance and too many changes are being made in foods and cooking techniques for you to fail to look at the newest specialized equipment, as well as to fail to look for changes in food preparation.

### Guideposts

1. Whom-----will you serve?
2. What-----will you serve?
3. How many-----will you serve?
4. Where-----will you serve?
5. When-----will you serve?



## COOKING AND BAKING EQUIPMENT

Types of cooking and baking equipment to be used will, of course, depend primarily on type of fuel available. New and improved refrigeration, food preparation, cooking and sanitation devices are constantly being developed. Many of these make possible better food products and also minimize food waste and labor. Careful study needs to be given the selection of equipment to make sure that each device will do the job expected of it and to make certain that it will be economical in the long run.

The suggested combinations of cooking and baking equipment listed may be varied to provide equivalent capacities in other combinations depending upon preferred methods of cooking.

Hood or canopy to be provided over all cooking and baking equipment.

It is recommended that cooking, baking and mechanical equipment be approved by and carry the following seals:

- |          |  |
|----------|--|
| N.S.F.   | - National Safety Foundation.  |
| U.L.     | - Underwriters Laboratory - All electrical equipment should carry this seal. |
| A.G.A.   | - American Gas Association   |
| N.E.M.A. | - National Equipment Manufacturers Ass'n.                                    |

### RANGE:

Commercial type: Available in two or more qualities. Cooking surface may consist of either solid top or open burners or a combination of the two. Heavy-duty, solid top desirable.

Range section: 30 in. to 36 in. wide; 34 in. to 42 in. front-to-back; 36 in. high when mounted on legs or masonry base. Actual cooking surface per section approximately 5 to 6 sq.ft. Available with oven or pan storage shelves, below cooking tops. Insulated ovens with automatic heat controls and removable racks.

Recommend approval by N.S.F. and either U.L. or A.G.A.

TOTAL LUNCHESES SERVED DAILY

100 - 200	200 - 350	350 - 500	500 - 750
1 Sections	2 Sections	2 Sections	2 Sections

Trend: Compartment steamers and steam jacketed kettle along with deck ovens and convection ovens make up principal cooking area of the kitchen. Ranges being used only when small amounts of liquid, and small amounts of food must be heated or prepared.

OVENS:

Baking and roasting: Single or multiple deck available. Multiple units may consist of bake or roast decks or a combination of the two. Automatic temperature controls at each deck level desirable. Roast deck suitable for either roasting, or baking; baking insert shelves also available for some models. Total deck capacity given in multiples of 18 in. by 26 in. bun or sheet pans or equivalent size for roasting pans.

Note: Oven space in range may be considered as part of total bake or roast oven capacity specified per meal food.

Recommend approval by: N.S.F. and either U.L. or A.G.A.

TOTAL LUNCHESES SERVED DAILY

100 - 200	200 - 350	350 - 500	500 - 750
3-deck (1 pan per deck)	3-deck (2 pans per deck)	3-deck (2 pans per deck)	2-deck (4 pans per deck)
or 2-deck (2 pans per deck)		or 2-deck (4 pans per deck)	or 5-deck (6 pans per deck) or 3-deck (4 pans per deck)

Convection ovens: A new concept in baking and roasting. Maximum production in minimum space. Select the model that meets your kitchen production needs and correlate its use with conventional roasting and baking ovens. Desirable features are, a dynamically balanced blower to give maximum circulation and even temperature distribution throughout the oven, completely porcelainized interior, accommodate standard oven pans, completely muffled and sealed permitting no products of combustion to enter or leave the oven chamber, a 3/4 h.p. driven motor, BTU rating specified, overload protection, a built-in starter switch, heavy-duty chrome-plated oven racks supported by removable oven rack guides to provide obstruction-free interior for cleaning, a control panel, all electrical and mechanical parts shall be serviceable from front of oven, two completely recessed shatter-protected long life oven lights; oven doors well balanced and of heavy-duty construction; highly tempered double glass oven windows, and equipped with a timer. May be purchased single or double deck.

Purchase of this piece of equipment is optional. Number purchased to be coordinated with oven space available.

Recommend approval by N.S.F. and either U.L. or A.G.A.

Purchase of this piece of equipment is optional. Number purchased to be coordinated with oven space available.

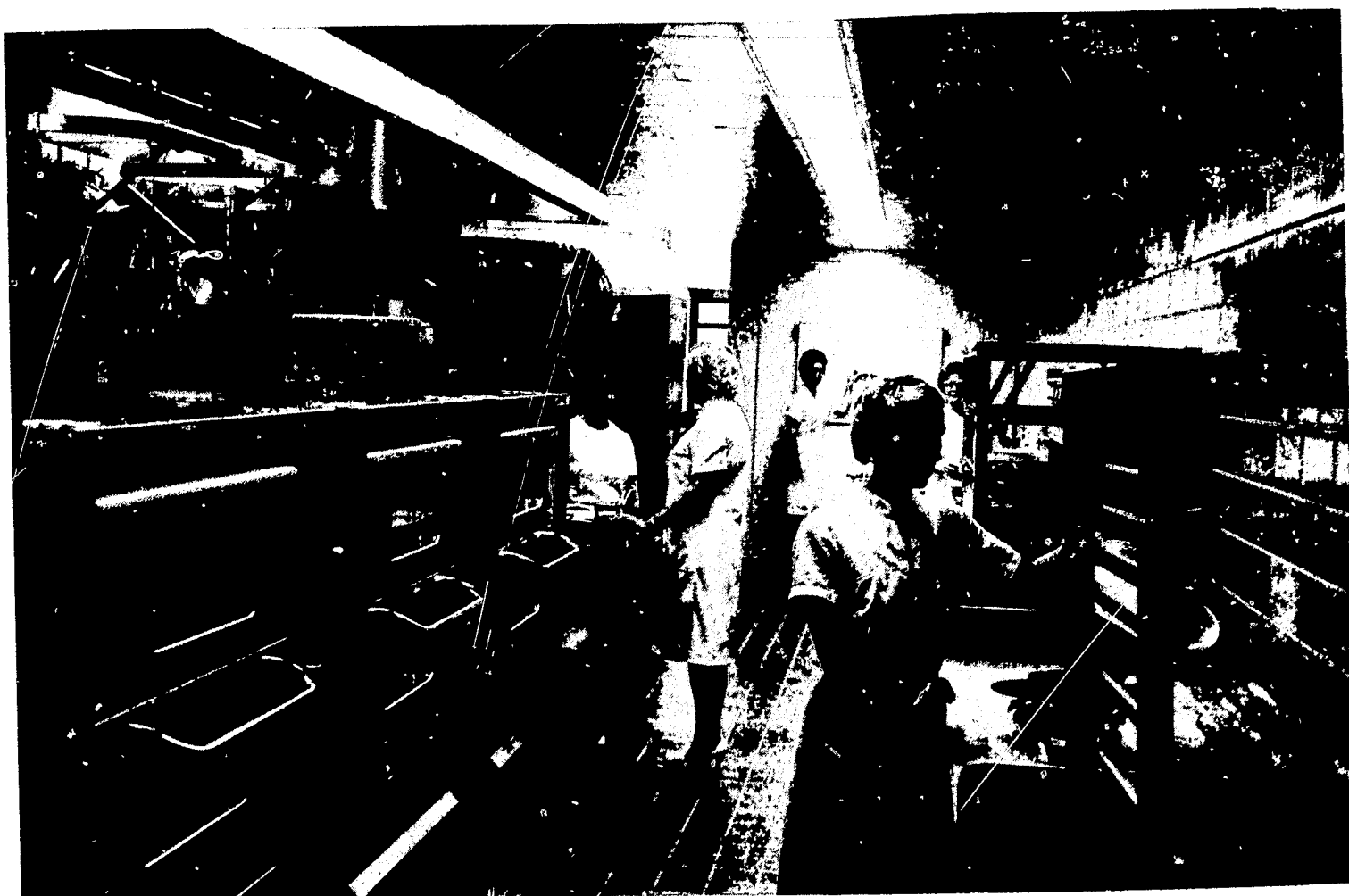

View of a kitchen area showing baking section, range top, deep fat fryer and combination walk-in and reach-through refrigeration.

#### STEAM EQUIPMENT:

Steam equipment: Steam may be applied from a central heating plant, directly connected to the equipment; or steam may be generated at point of use which requires hot and cold water; connection and means of heating it to form the steam; pressures vary according to needs, with automatic pressure control and safety valve if supply is above 5 to 8 lb/sq. in.; equipment of stainless steel or aluminum for rust resistance; smooth exterior and interior surfaces for easy cleaning and sanitation; timing and automatic shut-off devices; concealed control valves; steam cookers offer fast cooking in two general types.

Steam jacketed kettle: Aluminum or stainless steel. Full jacketed deep type with safety valve. Tilting or stationary. Tangent draw-off with removable swivel faucet desirable on stationary kettle to fill or clean. Self-contained gas or electric steam generator or direct connection to steam line. Use direct steam connection only if 15 lbs. per square inch minimum pressure is available during the entire school year. Where used provide pressure-reducing valve. Meter device for measuring water or internal measuring mark.

Installation: Kettles set for easy draw-off of food and drip into grated drain in floor or table; height convenient for workers.

- Types: (1) Deep kettles, fully or 2/3 jacketed - best for soups, puddings, pie fillings.
- (2) Shallow kettles, always full jacketed - suitable for braising and browning meats, stews. Prevents crushing of under layers of food as in deep type.
- (3) Trunion or tilting kettles mounted on trunions with tilting device and pouring lip for easy unloading; either power-driven or manual mechanism, self-locking devices to secure kettle in any position.

Recommend approval by N.S.F. and either U.L. or A.G.A.

TOTAL LUNCHESES SERVED DAILY

100 - 200	200 - 350	350 - 500	500 - 750
1 (20 gal.) (Optional)	1 (20 gal.)	1 (30 gal.) or (2-20 gal.)	1 (20 gal.) and (1-30 gal.)
Equivalent capacity in smaller, tilting table-mounted kettle may be preferred.			

Compartment steamer: Each compartment minimum 1 bushel capacity. For cooking under pressure (5 lb. or higher). Interior of stainless or galvanized steel; exterior finish of stainless steel or enamel. Safety valves and air vent; safety lock on doors; timer optional. Perforated and solid stainless steel baskets available. Self-contained gas or electric steam generator or direct connection to steam line. Use direct steam connection only if 15 lbs. per sq. in. minimum pressure is available during entire school year. Where used, provide pressure-reducing valve. (Atmospheric type steamer, is also available). Install in drip pan or floor depression with drain and hood with adequate ventilation.

Recommend approval by N.S.F., and either U.L. or A.G.A.

TOTAL LUNCHEES SERVED DAILY

100 - 200	200 - 350	350 - 500	500 - 750
1 Compartment or Cabinet type (Minimum 3-12 in. by 20 in by 2 in. pan capacity)	2 Compartment	2 Compartment	3 Compartment

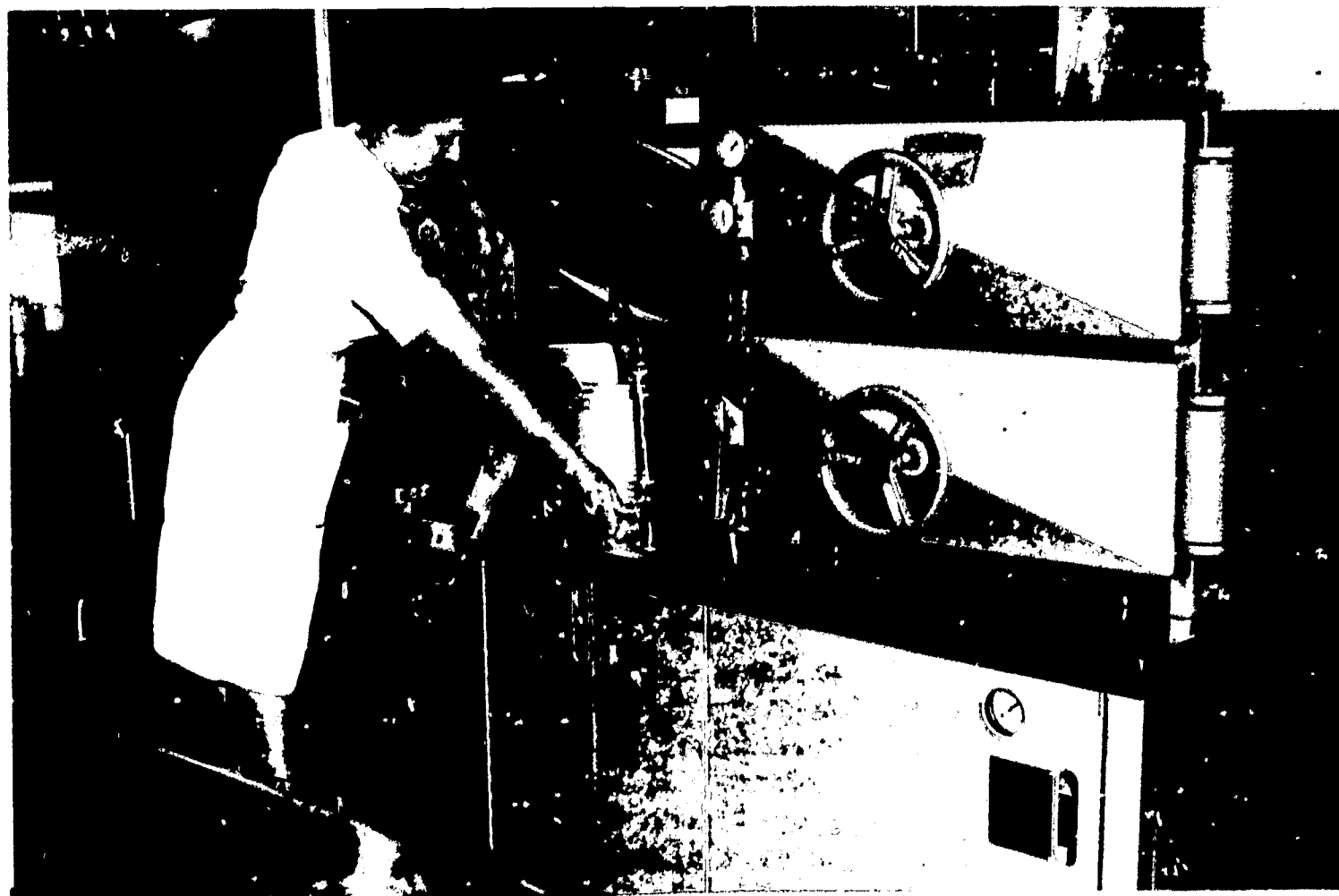

View of kitchen area showing steam jacketed kettle and compartment steamer.



**DEEP FAT FRYERS:** Gas fired models using fin type or tube fired heaters and electric models using hinged elements are available for heavy duty use. Some of these gas and electric models are equipped with a recessed zone in the frying container to catch food particles and hold them at 100° to 200° F. Improved filtering devices are obtainable. Desirable factors in selecting deep fat fryers are: Temperature control, fast recovery time, economic utilization of fat, flavor protection, cool sediment zone, self draining device, easy removal of sediment and filtering of fat, ease and safety of use and cleaning, sturdy, good design and size to fit your needs. Floor models or counter models are available. Rapid recovery is an important factor since this makes it possible to decrease batch times and increase quantity produced. Automatic fryers are available with timers. Frying may be done under pressure reducing cooking time. When positioning fryers, allow 16 in. spacing. Fryers should fry from 1½ to 2 times their weight of fat per hour. Adequate ventilation necessary.

Recommend approval by: N.S.F., and either U.L. or A.G.A.

Purchase of this piece of equipment is optional.

**TOTAL LUNCHESES SERVED DAILY**

100 - 200	200 - 350	350 - 500	500 - 750
15 lb. capacity 6 KW or 20,472 BTU	24 to 30 lb. capacity 9 KW or 30,708 BTU	29-60 lb. cap- acity 12 KW or 40,944 BTU	Combination of units deter- mined by space and power ser- vices

**HOODS OR CANOPIES:**

To be provided over all cooking and baking equipment. Hoods are used for the removal of heat, grease, moisture and steam. Sizing and height from the heat source are important. Canopies should usually have about a 2 inch overhang for each foot above the equipment. The usual clearance of the canopy is 5 ft. above equipment and a minimum of 6 ft.3in. where workers pass under. To work properly, canopies should be at least 2 ft. from the bottom edge to the top, and one outlet should be provided for every 6 to 8 linear feet of canopy. In some instances a ventilator or backshelf hood is now preferred. These units sit about 18 to 22 in. above equipment and give the strongest pull of air where it is most needed. They may vary from 200 cfm to a high of 350 cfm per lineal foot of appliance.

The National Fire Protective Association recommends that all hoods be equipped with grease filters or be provided with a fire extinguishing system that meets their No. 96 Standard. Filters should not be installed less than  $3\frac{1}{2}$  ft. above an open flame and not less than  $4\frac{1}{2}$  ft. above charcoal flames. Filters should be easily removable and of a size easily sent through the dishwasher.

Canopy hoods should be integrally constructed with smooth surfaces, free of crevices, trim or other projections. Suitable drains should be provided for condensation and grease troughs not less than  $1\frac{1}{4}$  by  $1\frac{1}{4}$  in. and should permit easy cleaning. Baffles, dampers, turning vanes, should be easily removable and cleanable. An automatic device should be provided to close dampers and vents when temperatures go over  $360^{\circ}$  to  $400^{\circ}$  F. Hoods should be rigidly supported to equipment, wall or ceiling. Marine-type or sealed-in vapor-proof lights should be installed as required for proper illumination.

#### MECHANICAL EQUIPMENT

Mixer: Heavy duty, bench or floor model. Sizes available and most commonly used on school lunch are 20 qt., 30 qt., and 60 qt. models with extra bowls as specified. The size should be in keeping with the capacity of related equipment. Large mixers should be purchased with bowl dollies, adapters, and,

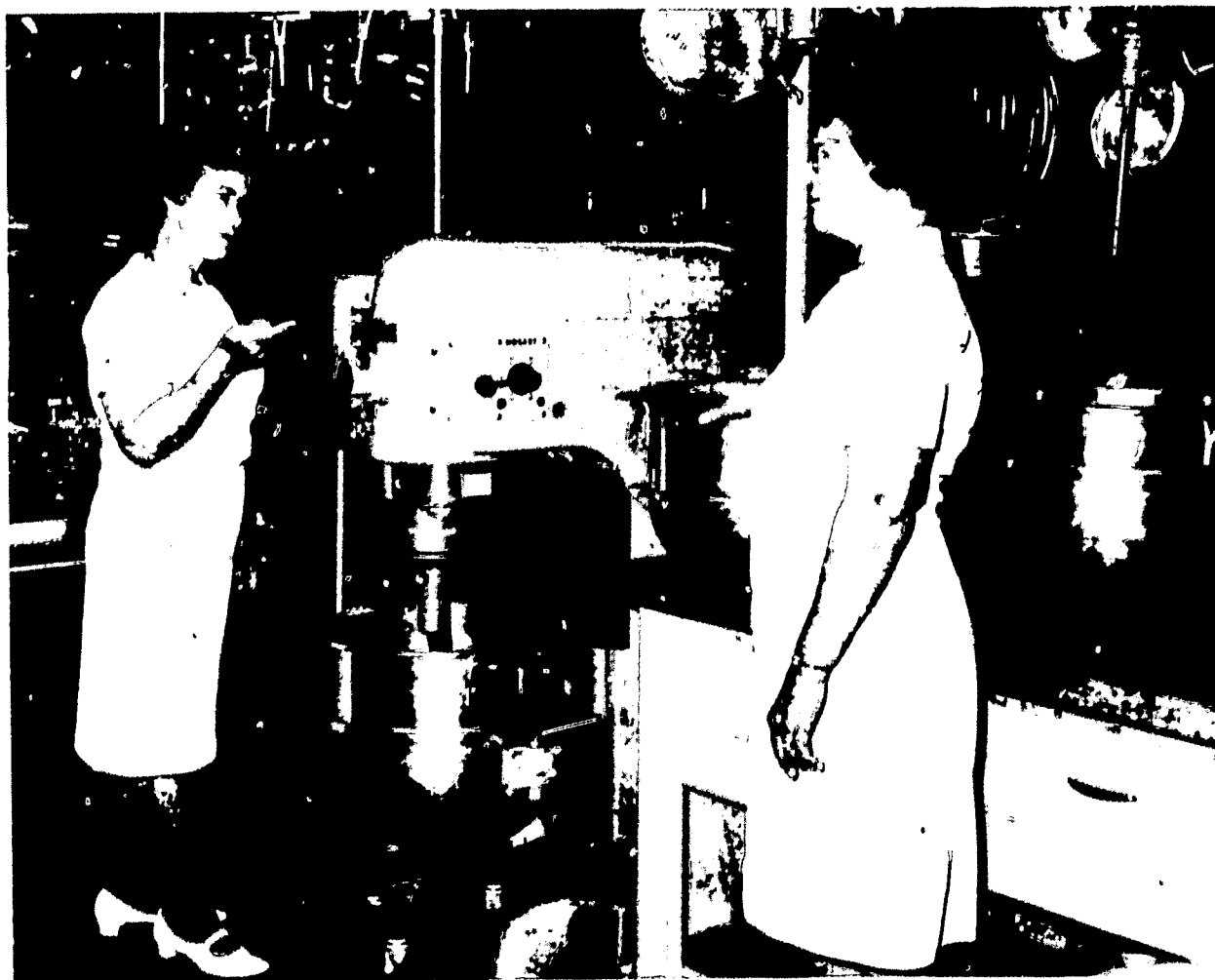

View of kitchen showing mixer and work table

if possible, with an electric bowl raiser and timer. Other desirable attachments to include are an oil dropper, bowl splash cover extension rim, pouring chutes, vegetable slicer with grater or shredder plates, dicer, meat and food chopper, beater, whip, and dough hook.

Important selection points are ease of cleaning and sanitary use, satisfactory performance, desirability, compactness of space requirements, appearance and ease of operation and maintenance. Sealed-in motor advisable. Large mixers should be fastened to the floor. Mobility is frequently desirable for small mixers.

Recommend approval by N.S.F. and U.L.

#### TOTAL LUNCHES SERVED DAILY

100 - 200	200 - 350	350 - 500	500 - 750
1	1 (With 2 extra 20 qt. bowls)	2 (With 2 extra 20 qt. bowls)	2 (With 2 extra 20 qt. bowls) or 1-60 qt. with dolly with 30 qt. & 40 qt. adapter. (bowls & beaters)

Slicer: Complete with attachments, electric, table or pedestal type available. Gravity or mechanical feed; safety device; stainless steel, aluminum, or chip-proof porcelain enamel finish. Small size approximately 6 in. cutting capacity. Large size approximately 9 in. cutting capacity. The vertical blade type is less desirable for slicing foods that crumble or fold as they are sliced. The angle blade type is preferred. The diameter of the knives vary 10 to 11 7/8 in. The diameter of the knife limits the size or diameter of the material sliced to approximately one-half its diameter. Knives should be of high quality steel, taking a keen edge, and holding it. The slicer should be equipped with sharpening stones that are easy to use on the machine. Knives should be well guarded. Select a model easy to take apart for thorough cleaning. Some slicers have self-contained portion seals to weigh portions as they are sliced and others have counters that count the portions as they are sliced.

Recommend approval by N.S.F. and U.L.

TOTAL LUNCHESES SERVED DAILY

100 - 200	200 - 350	350 - 500	500 - 750
1 small (Optional)	1 small	1 large	1 large



View of a kitchen area showing slicer, mixers, deep fat fryer and section of baking area

Cutter or chopper: Electric; table type; revolving bowl, 15 in. to 20 in. in diameter; safety device; bowl and knife guard readily removable for cleaning. Attachments may be obtained.

Food choppers or grinders may operate as an attachment on another motor-driven piece of equipment but for heavy work independent equipment is preferred. Important selection points are the manner in which the chopper cuts, safety and sanitary factors. Plates from 1/8 to 1/2 in. are available. Usually a feed pan and wooden stomper are furnished with the machine. The cylinder may be horizontal or at a slant to provide gravity flow.

Recommend approval by N.S.F. and U.L.

#### TOTAL LUNCHESES SERVED DAILY

100 - 200	200 - 350	350 - 500	500 - 750
		1	1
May use mixer attachment			

Note: Current trends are toward faster operating and more specialized equipment such as the Vertical Cutter Mixer, Food Shapers, Dough Dividers, Dough Rollers.

Peeler: Vegetable: 15 lb. to 20 lb. capacity; portable bench, pedestal or cabinet types available; aluminum, cast iron, or steel; abrasive-lined. Integral food-waste disposer or built-in peel trap desirable; or attach strainer basket on waste outlet from peeler. The capacity of the potato peeler is intentionally low since the newer models take only a few minutes to process one load, and can turn out the quantity of peeled potatoes needed within a short time. Though peelers vary in size from 15 to 70 lb. capacity, loads of more than 20 pounds would be difficult to handle when no male help is available. Mobile peeler models may be moved away from the sink when not in use so that the sink may be used more conveniently for other purposes.

Purchase of this piece of equipment is optional and is decreasing as the trend toward pre-prepared and low moisture food is increasing.



**REFRIGERATORS:**

The capacities and the combinations of refrigeration facilities suggested may need to be varied depending on location of school, frequency of delivery, use of central storage, etc. The capacities listed are exclusive of milk storage. See serving area for type and location of milk refrigeration and service.

Reach-in: Institutional type; minimum size 25 cu. ft. aluminum, stainless steel, or porcelain enamel interiors and exteriors; verminproof insulation; hinged or sliding doors with rotproof gaskets and plated or stainless steel hardware. Interior fitted with door-operated electric lights, adjustable plated wire shelves or non-corrodible slides for trays. Blower type cooling unit connected to self-contained or remote refrigeration equipment. Optional features: doors on both sides for pass-through; locking hardware. Approximately 1/4 to 1/3 cu. ft. per meal served. Consider reach-in walk-in combination when total capacity exceeds 60 cu. ft. Consider pass-through type between kitchen and serving areas for approximately 30-40 cu. ft. and 40-60 cu. ft. capacities.

Recommend approval by N.S.F. and either U.L. or A.G.A.

Walk-in: Sectional commercial type or built-in as part of building contract. May be several separate rooms with varying temperature and humidity conditions. Vermin-proof insulation on walls, floor, ceiling; interior stainless steel or glazed tile preferable; Portland cement plaster acceptable. Doors on heavy hinges with compression-type gaskets; door latches with integral keyed lock and interior safety latch, which can be opened from inside. Half-height reach-in doors also available; arrange for opening into kitchen area. Interior shelving, wood, or metal, portable type desirable. Blower - type refrigeration coils connected to remote refrigeration equipment. Service and maintenance features important as part of purchase contract.

**TOTAL LUNCHESES SERVED DAILY**

100 - 200	200 - 350	350 - 500	500 - 750
May be desirable		1	1
no	desirable but not necessary	approx. 8 ft. by 10 ft.  (May be combination walk-in, reach-in)	approx. 8 ft. by 14 ft. or larger

Frozen food storage cabinet: Commercial; upright type is preferable; 1 fixed freezing shelf; other shelves adjustable and/or removable for maximum storage.

Size depends on local needs such as location of school, food purchasing practices, frequency of delivery, use of central storage, etc. One cu. ft. stores approximately 30 to 35 lbs.

Refrigerator thermometers: Refrigerator - freezer. Remote reading type or one designed to hook on shelf or partition; temperature range of at least minus 40° to plus 60° F. in 20 scale divisions; red-liquid-filled magnifying-glass tube for easy reading; rust-proof scale and frame; scale encased.

One for each reach-in refrigerator and frozen food cabinet.

Single-pen recording: Designed to record temperatures continuously 7-day revolution chart graduated from at least minus 40° to plus 70° F. in low-scale divisions; mercury-actuated thermal system with temperature-compensated smooth capillary; rectangular aluminum dust-proof case; lock in door to prevent tampering.

One for each walk-in refrigerator.

#### SINKS:

Cooks', vegetable preparation, and pot washing: Stainless steel; welded seamless construction; sanitary inside corners (coved); integral rims, splashboards, and drainboards that slope toward sink for draining. Bottom sloped to drain through removable stainless steel strainers into waste; exterior-operated lever waste control desirable. Mixing faucet with swing-spouts located for filling each compartment. Mount entire fixture on sanitary metal legs or concealed wall hangers.

Cooks' sink: Installed in cooks' table or near ranges; inside measurements, approximately 15 in. by 15 in. by 8 in. to 12 in. deep. Long swing-spout mixing faucet mounted 24 in. above range top or over steam jacketed kettles also desirable. Optional up to 350 lunches - one per unit serving 350 to 750 lunches.

Vegetable preparation sink: Two or more compartments; each compartment approximately 20 in. by 20 in. by 12 in. to 14 in. deep, inside measurements. Front rim 34 in. to 38 in. above floor. Two drainboards, at least 24 in. long, draining into sink. Optional or 1 per unit. Depth of sink to be 22 in. by 24 in. by 14 in. if potato peeler is used. Waste disposer needed under this sink. Second sink 22 in. by 24 in. and 12 in. deep.

Pot sink: Two or three compartments as required by local and State regulations; each compartment not smaller than 24 in. wide, 24 in. front-to-back; 12 in. to 16 in. deep, inside measurements. Sink bottom at least 24 in. above floor; front

rim 36 in. to 40 in. above floor. Splashboard on rear, 10 in. to 15 in. high, turned back 2 in. on top and sides to conceal water supply pipe; high faucet mounting, 20 in. minimum clearance under faucet to sink bottom. Thermostatically-controlled booster heater or auxiliary heating cycle such as side-arm heater for maintaining 180° F. water in final sanitizing compartment. Two drainboards at least 24 in. long, draining into sink. Grease overflow compartments and food waste disposers optional accessories. To clear 18 in. by 25 in. bun pans it is suggested that faucet mounting be 6 in. higher and splashboard height increased correspondingly.

One per unit - may be installed in kitchen or in dishwashing unit, convenient to cooking area.

Hand lavatory: Stainless steel, vitreous china, or acid-resisting porcelain enamel on cast iron; standard size, mixing faucet with foot-operated control valves; stops and trap. Provide soap dispensers and towel dispensers or automatic hand dryers.

Consult local authorities regarding number and location required.

TABLES:

Bakers', cooks', and vegetable preparation: 34 in. to 36 in. working height; 24 in. to 30 in. wide if used on one side only, 42 in. to 48 in. wide if used from both sides; center overhead shelf if double service type. If table use requires cutlery, provide drawer, approximately 20 in. by 20 in. by 5 in. deep. Space under table top may be enclosed storage cabinet, lower metal shelf between table legs, or open to floor for storing portable bins, trucks, etc. Mount tables on tubular legs with sanitary adjustable feet or on casters with brakes. Consult local authorities for approval before ordering wood top tables.

Bakers' table: 3 in. thick laminated maple strip top, stainless steel top, or 1½ in. thick polished marble top. Base open for storing portable bins, overhead rack.

TOTAL LUNCHES SERVED DAILY

100 - 200	200 - 350	350 - 500	500 - 750
1 5 ft. to 6 ft. (Optional)	1 6 ft. to 8 ft.	1 6 ft. to 8 ft.	1 6 ft. to 9 ft.

Cooks' table: 14 gauge stainless steel or 12 gauge stainless steel if working surface is 12 ft. or more, or laminated maple strip top, one or two drawers. Overhead utensil rack optional; approximately 7 ft. 6 in. above floor. Lower shelf, 18 gauge stainless steel for storage cabinet.

TOTAL LUNCHESES SERVED DAILY

100 - 200	200 - 350	350 - 500	500 - 750
1 5 to 6 ft.	1 6 to 8 ft.	1 6 to 8 ft.	2 6 to 9 ft.

Vegetable preparation table: Stainless steel or laminated maple strip top; two drawers; removable cutting board, lower shelf or storage cabinet.

TOTAL LUNCHESES SERVED DAILY

100 - 200	200 - 350	350 - 500	500 - 750
1 5 to 6 ft.	1 6 to 8 ft.	1 6 to 8 ft.	2 6 to 9 ft.



View of stainless steel table and sink combination



Utility trucks: For all purpose use in kitchen. Stainless steel or aluminum, approximately 38 in. long, 22 in. wide, 36 in. high; two or three decks; rubber-tired ball-bearing wheels; rubber bumpers; two rigid and two swivel wheels preferable, or four swivel wheels if desired.

TOTAL LUNCHESES SERVED DAILY

100 - 200	200 - 350	350 - 500	500 - 750
1	1-2	2-3	2-3

RACKS:

Cooling: Portable; 4 to 6 slatted shelves or angle slides.  
Utensil: Portable; 4 to 6 slatted shelves. May be desirable for units serving 350 to 750 lunches daily.

Number depends on local needs, amount of baking done, etc.

OTHER:

Mobile equipment: Mobile food service equipment is designed to provide flexibility, convenience, savings in space and economy in operation. Mobile elements in the line make it possible to provide facilities that vary as the need requirements vary.

The possibility of using conveyors, rollers, self-leveling devices for dishes, glasses and cups, with heated and refrigerated cabinets and other labor-saving devices could be considered in larger operations. The slogan, "put it on wheels!" should be kept constantly in mind.

Mobile equipment is used in three ways, in the dining area, the food preparation area, and for foods that travel. Yet whatever area of use is to be designated, there are certain purchasing considerations common to all types of wheeled equipment.

How much can we use it and where can we park it when not in use? These are the twin considerations repeatedly mentioned.

Dimensions, small enough to get through aisles and doorways and short enough to be maneuverable.

Construction scaled to weight and use requirements.

Function with existing dumbwaiters and elevators. Proper relation of cart mass and door control beam.

Adequate capacity.



Floor space needed for storage.

Ease of cleaning.

Easy to move.

Wheel construction.

Bumper placement.

Operating efficiency of all wheeled equipment is determined by how well it rolls, how easily it can be stopped. Casters, motors, and braking determine ease of maneuverability.

Generally, casters are rubber or synthetically tired, 5 in. in diameter and designed to swivel if carts must be maneuvered sideways as well as backward and forward.

Carts may be directed more easily in a straight line if casters at one end are rigid. Carts fitted with wheel-locking devices may also be locked into position. Floor clamps are also used to lock carts.

When mobile equipment is designed for extremely heavy loads or where carts are to be moved by women, motorized casters are available.

Bumpers provide cart protection as well as protection for surrounding areas. Their size and weight is usually determined by the size and weight of the equipment and they are placed on the equipment in those areas most apt to be damaged or to be damaging during normal operational routines.

Only constant supervision and careful training can make mobile equipment personnel-proof.

"Driver training" for the mobile equipment operator will not only protect fellow employees; it will also protect walls, other equipment and the mobile items themselves.

Fire blanket: Fireproof woven asbestos approximately 48 in. by 72 in. for smothering grease or personal clothing fires. Generally stored in roll on wall brackets or in cabinet with breakable glass front panel. Number depends on layout of kitchen and State and local fire regulations.

Fire extinguisher: Type approved by State and local fire regulations. Size and number depend upon layout of kitchen and State and local fire regulations.

SMALL EQUIPMENT

TOTAL LUNCHESES SERVED DAILY

Beater: Rotary; manually operated; commercial type.

Boards: Cutting, hardwood, approximately 10 in. by 16 in. by 1 $\frac{1}{4}$  in.

Pastry, hardwood; approximately 18-in by 24 in. by 1 in.

Bowls: Mixing, aluminum or stainless steel.

3-4qt-----  
6-8 qt-----  
12-16 qt-----  
20-25 qt-----

Brushes: Various types and sizes available; corrosion-resistant handle.

Pastry-----  
Vegetable-----

Chopper or grinder, food: Manually-operated; corrosion-resistant cutters with variable type blades; approximately 3-lb. capacity-----

Cleaver: Light weight, 3/4 to 1 lb. approximately 6 in. blade; hardwood handle-----

Clock: Wall type-----

Colander: Aluminum or stainless steel; approximately 11 to 16-qt. capacity--

Cutlery: Blades of high carbon content or stainless steel; full tang construction desirable; minimum, 2 rivets; two piece hardwood handles or equivalent construction.

Boning, approximately 6-in. flexible, narrow blade-----

Boning, approximately 6 in. stiff wide blade-----

French cook's approximately 10 - in. blade-----

Paring, spear or clip point; approximately 2 $\frac{1}{2}$  to 3-in. blade-----

Peeler, hand type; floating blade----

100 - 200	200 - 350	350 - 500	500 - 750
1	2	2	2
1	2	2	2
(If no cook's table with maple top)			
1	1	1	1
(If no baker's or cook's table with maple top)			
4	4	2	2
2	2	4	4
2	2	4	4
1	1	2	2
2	2	2	2
2	2	3	3
Optional		Optional	
Optional		Optional	
As needed, depending on layout of work areas.			
1	1	2	2
1	1	2	2
2	2	3	4
2	4	5	6
2	3	3	3

SMALL EQUIPMENT - Continued

TOTAL LUNCHESES SERVED DAILY

Slicer, hotel or roast approximately 12-in blade-----

Spatula: regular flexibility approximately 8 to 10-in.

Narrow blade-----

Wide blade-----

Spreader, flexible, approximately 3 to 4-in. blade-----

Steel, sharpening, approximately 12 in. long, magnetized-----

Turner, "hamburger" stainless steel; approximately 3 to 4½ in. flat area--

Turner, or offset spatula, stainless steel; approximately 10-in. by 1½-in. blade-----

Cutlery rack: Type suitable to operation-----

Cutter, butter: Corrosion-resistant steel wires; 48 cuts per pound-----

Cutter, salad: Rotary type, manually operated; slicing, shredding, or grating cone cutters-----

Fork, pot: 2-tined, forged; hardwood handle or equal construction; approximately 14-in.-----

Garbage can and cover: Galvanized; 15 to 25-gal. available with or without casters or may be used on dollies.

Grater, hand: Heavy-duty; corrosion resistant metal; fine and coarse-----

Juice extractor: Aluminum or stainless steel; press or rotary type; manually operated-----

Ladles: Stainless steel for portioning. Long handle. Size-----

¼ cup (2 oz.)

½ cup (4 oz.)

¾ cup (6 oz.)

1 cup (8 oz.)

For general use. Short handle. Size: 2 to 4 cups (16 to 32 ounces)-----

Masher, potato: Heavy duty-----

100 - 200	200 - 350	350 - 500	500 - 750
1	1	2	2
1	1	2	2
1	1	2	2
May be desirable if sandwiches are made.			
1	1	1	1
2	2	3	3
2	2	3	3
Number and size depend on layout of work areas.			
Optional		Optional	
Optional		Optional	
2	2	2	2
One for each preparation area except where food waste disposer is easily accessible.			
Optional		Optional	
Optional		Optional	
Utilize ladles listed in serving area.			
1	1	2	2
1 (If no power mixer)	-	-	-

SMALL EQUIPMENT - Continued

Measures: Aluminum or stainless steel; seamless; liquid and dry type available. If only one type used, liquid type desirable.  
 1-cup size graduated in  $\frac{1}{4}$  cups-----  
 1-qt. size graduated in cups-----  
 2-qt. size graduated in cups-----  
 1-gal. size graduated in qts-----

Molder, hamburger: Aluminum, manually operated; fastened to table; approximately 7 in. by 14 in.; 6 patties per pound-----

Openers: Can, table model; heavy-duty; adjustable; parts removable for cleaning-----

Can and bottle; small hand type-----

Pots and Pans: Bake pans: aluminum or stainless steel; seamless; 2 drop handles, depth 2 in. to 3 in.; approximately 22 in. length by 20 in. width; or use serving counter pans, approximately 20 in. length by 12 in. width; or size suitable for maximum use of oven-----

Bread pans: Aluminum, stainless steel or tinned steel; seamless; 4 in. depth, approximately 10 in. length by 4 to 5 in. width-----

Bun or sheet pans: Aluminum, stainless steel, or tinned steel; seamless; 1 in. depth; approximately 26 in. length by 18 in. width; or size suitable for maximum use of oven. Aluminum available in both natural and anodized finish-----

Double boiler: Aluminum or stainless steel; semi-heavy; flat bottom insert; fitted cover. Insert and outer pot may be used separately.  
 12-qt. insert; 12-qt. pot-----  
 20-qt. insert; 20-qt. pot-----

TOTAL LUNCHES SERVED DAILY

	100 - 200	200 - 350	350 - 500	500 - 750
	2	2	3	3
	2	2	3	3
	2	2	3	3
	2	2	3	3
	Optional	Optional	Automatic type may be desirable.	
	1	1	1	1-2
	Additional number depends on layout of work areas.			
	1	2	2	2
	4	6	8	8
	Optional		Optional	
	6-12	6-12	12-24	12-24
	1	1	1	1
	-	1	1	1



SMALL EQUIPMENT - Continued

Muffin pans: Aluminum or stainless steel; commercial weight; 24 cups per frame; approximate cup size, top diameter 2 3/4-in.; depth 1 1/2 in.-----

Pie pans: Aluminum anodized finish, stainless steel, or tinned ware; 8- to 10-in. diameter-----

Roast pans: Aluminum or stainless steel; seamless; 2 drop handles; depth 5 to 6-in.; 20 or 22-in. length by 16- or 20-in. width; or size suitable for maximum use of oven-----

Sauce pans: Graduated in cups, aluminum or stainless steel; commercial weight; long handle; approximately 4 qt.-----

Sauce pots: Aluminum or stainless steel; commercial weight; 2 loop handles; approximately 20 qt; approximately 14-in. diameter-----

Stock pots, if no kettle or steamer: 10-qt.-----  
25-qt.-----

Utility or dish pans: Aluminum or stainless steel; commercial weight; with or without handles; 14 to 27 qts.-----

Pot holders or oven mitts:-----

Rolling pin: Heavy-duty; length 14 in., diameter 4 in., revolving handles, ball bearing-----

Saw, butcher's: Hardwood or metal handle; 20 to 24-in. blade-----

Scales: Table model to meet requirements for commercial type (family type scale not suitable); approximately 25- to 30-lb. capacity; 1/4 to 1/2 oz. graduations; platter top desirable-----

Heavy duty scale - 250 lb. size-----  
Bakery scales - 5 lb. size-----

TOTAL LUNCHESES SERVED DAILY			
100 - 200	200 - 350	350 - 500	500 - 750
Optional		Optional	
Optional		Optional	
1	2	2	3
1	1	2	2
2	2	3	3
4-6	4-6	3-6	3-6
1	2	3-6	3-6
Optional		Optional	
Number depends on layout of work areas.			
1	1	1	1
Not needed if all meat is received boned or cut in portion sizes.			
Additional number depends on layout of work areas--desirable in cooking, baking, and salad preparation areas.			
1	1	1	1
1	1	1	1
1	1	1	2



SMALL EQUIPMENT - Continued

TOTAL LUNCHES SERVED DAILY

Scoops: Dishers for portioning; stainless steel; wood or plastic handle. Size:

- No. 6 (2/3 cup)
- No. 8 (1/2 cup)
- No. 10 (2/5 cup)
- No. 12 (1/3 cup)
- No. 16 (1/4 cup)
- No. 20 (3 1/5 tbsp.)
- No. 24 (2 2/3 tbsp.)
- No. 30 (2 1/5 tbsp.)
- No. 40 (1 3/5 tbsp.)

Dry ingredients: aluminum or stainless steel; 1 qt.-----

Scraper, bowl: Flexible nonmetallic blade, 4 to 6 in. wide-----

Shakers: Aluminum or stainless steel approximately 3 in. diameter, 4 in. depth-----

Shears: Kitchen, steel; 7 to 8 in.--

Sieve: Flour, aluminum 16 to 20 in. diameter-----

Slicer, egg: Aluminum, chromium, or stainless steel-----

Spoons: Measuring; aluminum or stainless steel; graduated 1/4 tsp. to 1 tbsp.-----

Mixing; stainless steel; 11 to 13 in. long; solid-----

Slotted or perforated-----

Stools: Metal or wood-----

Strainer, china cap; stainless steel; 10 to 12 in. diameter-----

Trays: Aluminum or stainless steel; approximately 12 by 16 in. or 14 by 18 in.-----

Whip: Corrosion-resistant wire; 14 to 20 in.-----

100 - 200	200 - 350	350 - 500	500 - 750
At least one of each size. Desirable for portioning meat patties, some vegetables, salads, muffins, drop cookies, etc.			
One for each container of dry ingredients; i.e., flour, sugar, beans, etc.			
2	2	4	4
Desirable for dispensing salt, flour, sugar, etc.			
1	2	2	2
1	1	2	2
Optional		Optional	
2 sets for each work area.			
4 2	6 4	8 6	8 6
Additional number depends on layout of work areas.			
As needed.			
1	1	2	2
4	4	6	6
2	2	3	3

SMALL EQUIPMENT - Continued

Serving implements:

Scoops: (dishers for portioning); stainless steel; wood or plastic handle. Size:

- No. 6 (2/3 cup)
- No. 8 (1/2 cup)
- No. 10 (2/5 cup)
- No. 12 (1/3 cup)
- No. 16 (1/4 cup)
- No. 20 (3 1/5 tbsp.)
- No. 24 (2 2/3 tbsp.)
- No. 30 (2 1/5 tbsp.)
- No. 40 (1 3/5 tbsp.)

Spoons, serving: Stainless steel; 11 to 13 in. long.

Solid-----  
Slotted or perforated-----

Tongs: Aluminum, chromium, or stainless steel; 9 to 12 in.-----

Turners or offset spatulas; stainless steel, approximately 10 by 1 1/2 in. blade-----

Dispensers:

Napkin: Corrosion-resistant material--  
Straw: Corrosion-resistant material--  
Pitchers: Aluminum or stainless steel; 4 to 5 qt.-----  
Shakers: Salt and pepper, aluminum or stainless steel - for serving counter or dining tables-----

Other:

Cash register: Desirable to use type with keys to register types of lunches served-----

Checking machine: From 1 to 5 or more keys; tape receipt type available----

Menu board: With plastic letters and figures-----

Recipe card holders-----

TOTAL LUNCHESES SERVED DAILY

100 - 200	200 - 350	350 - 500	500 - 750
At least one of each size for each serving counter.			
2-3	2-3	3-4	4-6
2-3	2-3	3-4	4-6
2-3	2-3	3-4	4-6
2-3	2-3	3-4	4-6
At least one for each serving line. At least one for each serving line.			
Optional		Optional	
Optional		Optional	
Usually not necessary in elementary schools. If used, one for each serving line.			
One for each serving line. Locate a few feet ahead of changemaker or cash register.			
Optional		Optional	
Optional		Optional	

## SERVING AREA

**PURPOSE:** To provide a quick, orderly and pleasing method of portioning and serving school lunches, to protect foods from oral infection and other unsanitary conditions; to conserve nutritive value and flavor of food.

**LOCATION:** May be within kitchen area, in a separate room or in the dining area used as a multi-purpose room. It may be separated from the dining room by doors and a partition, depending upon the size of the program. In any event serving of patrons should never be in the kitchen proper.

**SPACE:** The amount of floor space that must be allotted to the serving area depends primarily upon the number of serving lines installed. In addition to the customary fixed serving counter mobile serving sections may be added or an entire mobile serving counter may be planned.

These in turn, depend upon the length of the noon hour and the schedule for releasing classes for lunch. Generally approximately 10 sq.ft. floor area per meal served daily is sufficient. This area may be added to recommended kitchen or dining area if function is included in that area.

### CONSTRUCTION FEATURES:

Consult State and local authorities having jurisdiction over applicable regulations.

Lighting and wiring: Comply with National Electrical Code requirements (an American Standard) together with other local requirements. Lighting over serving surfaces approximately 50 ft.-candles; normally achieved by about 5 watts per sq. ft. of floor area.

Other considerations: Provide some general features of construction as kitchen area.

**EQUIPMENT:** Fixed serving counter: 28 to 30 in. wide (including tray service); approximately 34 in. working height; stainless steel top preferable; substructure may be metal, wood, or masonry, mounted on solid base or legs, at least 6 in. high, lower shelves, cabinets, or open space underneath for dish trucks, conforming to State and local regulations. Available as a manufactured product or may be locally built; approximately 15 to 20 ft. in length. To include space for trays, tableware, cashier or checker, and hot and cold food sections exclusive of milk.

or

Trend toward mobile serving sections: Consideration of the versatility of mobile serving sections is of much importance in

planning for food service in secondary schools. Shelving for food display of pre-proportioned and dished food items should be provided. This type of food service counter lends itself to planning for and serving a variety of foods within the menu - selection of food items within each component part of the lunch, to different priced lunches and short specialty lines. Used as extra lines such wheeled pieces add flexibility to operations which were originally limited to a fixed counter.

Tray section: At the beginning of the line, room must be provided for a tray section, either as an integral part of the counter or in form of a portable cart or platform. This will require up to 2 ft. or approximately 24 in. high, 18 in. long. One for each serving counter.

Hot food section: For main dishes and vegetables. The hot food section should have at least four rectangular openings to accommodate standard 12 by 20 in. pans of different depths or a combination of smaller pans with the aid of pan adapter bars. If heat is deemed necessary, dry heat should be provided and a separate easily accessible heat control for each pan space is desirable. Require approximately 6 to 8 ft.

Cold food section: For display and shelf service of breads, salads, fruits and other desserts. Plain counter top, elevated shelves, or refrigerated unit. Approximately 6 ft.

Protector or "sneeze" guard - for protecting unwrapped foods from airborne bacteria. Entire length of hot and cold sections of counter. A land shelf over the guard is desirable, but a reach-through space under the guard is also needed, especially if elementary children are served or if self service in the cold food section is intended. The guards may be hinged for easy cleaning and should be vented below the upper shelves to prevent steaming. Comply with State and local regulations.

Tableware section: Approximately 20 in. counter space or use part of tray section to accommodate removable cylinder or individual pans with half covers for sanitation. One for each serving counter.

Checker or cashier's section: Approximately 24 in. long with end of counter recessed for knee space. Bottom shelf may act as footrest or may be omitted. Locked cash drawer optional. Note: If mechanical register is desired, provide electric connection. One for each serving area. May be separate table and seat. Put on wheels!

Tray rail or slide: Preferably metal; solid or tubular, approximately 12 in. wide. Approximately 28 in. high for primary and elementary schools; 32 in. high for junior and combined high and elementary schools; 32 to 34 in. high for high schools. Entire length of counter.



Back counter: Behind serving counter aisle. Convenient for auxiliary work areas. May include pass-through hot food cabinet and pass-through refrigeration for receiving foods from kitchen. Optional.

Milk service: Needed in addition to other refrigeration. Usually located adjacent to serving counter.

Cooler: For individual 8 oz. containers. Preferably self-service, horizontal chest, mechanically cooled. May include automatic elevating device to keep containers at top of cooler. 1 cu. ft. net capacity for 50 to 75 half-pints of milk, depending on size and shape of containers.

**SMALL EQUIPMENT:** Quantity of the following to equal meal load preferable. Two thirds may be adequate if washed and reused during the serving period.

Trays: Various qualities and materials available; 12 by 16 in. or 14 by 18 in. desirable sizes. Trays can add color and beauty to your food service. If purchased with the name of the school or school seal molded into the tray surface a great deal of customer interest is added.

Sectional trays: It is recommended these be used in elementary grades only. May be purchased in various sizes and qualities of materials. Any desirable size. Made with detergent and high heat-resistant qualities. Sanitary;- smooth surfaced, rounded corners and easily stacked. Resistant to chipping, peeling, cracking, warping, denting, bending and splitting.

Dinnerware: Heavy-weight, rolled edge, vitrified china, plastic not affected by boiling water or chlorine solutions, or heat-resistant glass.

Plates, dinner: 8 to 9 in. overall diameter; or compartment type.

Plates, bread and butter: Approximately 6 in. overall diameter.

Soup bowls: Approximately 10 oz. capacity.

Fruit dishes: Approximately 4 oz.

Cups: Approximately 8 oz. (optional)

Tableware: Knives, forks, teaspoons and soup spoons. One piece construction; stainless steel or triple-plate silverware. Quantity to equal meal load.



TOTAL LUNCHES SERVED DAILY

Serving implements:

Fork, serving: 2-tined, forged hardwood handle or equivalent construction; approximately 10 or 12 in.

Ladles: Stainless steel; long handle size:

- $\frac{1}{4}$  cup (2 oz.)
- $\frac{1}{2}$  cup (4 oz.)
- $\frac{3}{4}$  cup (6 oz.)
- 1 cup (8 oz.)

Spoons, serving: Stainless steel; 11 to 13 in. long.

- Solid
- Slotted or perforated

Tongs: Aluminum, Chromium or stainless steel, 9 to 12 in.

Turners or offset spatulas: Stainless steel; approximately 10 by  $1\frac{1}{2}$  in. blade.

Cake server: Aluminum, chromium or stainless steel; - width, 3 in.

	100 - 200	200 - 350	350 - 500	500 - 750
	1 - 2	2 - 3	3 - 4	4 - 5
	1 - 2	2 - 3	2 - 4	2 - 4
	1 - 2	2 - 3	2 - 4	2 - 4
	1 - 2	2 - 3	2 - 4	- 4
	1 - 2	2 - 3	2 - 4	2 - 4
	2 - 3	2 - 3	3 - 4	4 - 6
	2 - 3	2 - 3	3 - 4	4 - 6
	2 - 3	2 - 3	3 - 4	4 - 6
	2 - 3	2 - 3	3 - 4	4 - 6
	1	1	2	2

At least one of each size of the following for each serving counter.

Scoops: (dishers for portioning) stainless steel, wood or plastic handle. Sizes:

- No. 6 ( $\frac{2}{3}$  cup)
- No. 8 ( $\frac{1}{2}$  cup)
- No. 10 ( $\frac{2}{3}$  cup)
- No. 12 ( $\frac{1}{3}$  cup)
- No. 16 ( $\frac{1}{4}$  cup)
- No. 20 (3  $\frac{1}{5}$  tbsp.)
- No. 24 (2  $\frac{2}{3}$  tbsp.)
- No. 30 (2  $\frac{1}{2}$  tbsp.)
- No. 40 (1  $\frac{3}{5}$  tbsp)

Dispensers: At least one for each serving line.

- Napkin: Corrosion resistant material
- Straw: Corrosion resistant material

Pitchers: Aluminum or stainless steel; 4 to 5 qt. (optional)

Shakers: Salt and pepper, aluminum or stainless steel. For serving counters or dining tables.(optional).

Other:

Cash register: Usually not needed in elementary schools. If used, one for each serving line.

Checking machine: From 1 to 5 or more keys; tape receipt type available. One for each serving line. Locate a few feet ahead of changemaker or cash register.

Menu board: With plastic letters and figures. (optional).

## DISH RETURN AND DISHWASHING AREA

### PURPOSE:

To provide a satisfactory method of dish return, dishwashing and dish handling which are vital to sanitary food service, the pleasure of the patrons and the economy of operation. To sanitize dinnerware; to collect and dispose of garbage and trash from dining area; to reduce breakage losses and other losses of dinnerware caused by improper handling.

### LOCATION:

Dish return: Adjacent to the dining area so that soiled dishes may be returned by students, near exit from dining area to corridors or outdoors, arrange location so as to eliminate cross-traffic interfering with incoming students. To be recessed and screened off the dining area. To provide for double line return for larger operations. Installation of a continuous belt from the lunchroom to the dishwashing area is not justified in most school facilities.

Dishwashing: Adjacent to dining and dish return areas. Separate room simplifies ventilation and noise control. May be in kitchen with sound and ventilation baffle.

### SPACE:

Floor area determined by plan of dish return, type and size of dishwashing equipment, table space required for peak-load periods and traffic patterns in and out of area. Approximately 60 to 80 sq. ft. for unit with compartment sink; 105 to 108 sq. ft. for unit with compartment sink; 105 to 108 sq. ft. for unit with single tank dishwashing machine, 180 to 210 sq. ft. for unit with two-tank dishwashing machine.

### CONSTRUCTION FEATURES:

Consult State and local authorities having jurisdiction over applicable regulations.

Floor: Slip-resistant, terrazzo, quarry tile, or concrete with integral hardener. Check local regulations regarding floor drains.

Walls: Light in color, smooth, impervious to moisture, easy to wash and keep in good repair. Glazed tile most desirable; painted plaster or masonry acceptable for areas not subject to splashing and daily washing; plasterboard or wood not desirable. Coved bases at floor line. Local regulations may require coved vertical corners. Metal corner guards, preferably stainless steel, on all projecting corners subject to traffic damage. Sound-proofing between dishwashing area and other areas desirable.

Ceiling: Light in color, smooth, impervious to moisture, easy to wash and keep in good repair. Non-absorbent, rodent-proof, fire resistant, acoustical type desirable; mechanical suspension system less affected by steam and heat than adhesive attachment of acoustical materials. Painted waterproof, mildew-resistant plaster or cement may be used.

Windows: If provided, locate for cross ventilation. Low enough for good ventilation and light but high enough to permit alignment of equipment along outside walls, 48 in. sill height, usually adequate. Provide good locks.

Soiled dish return to dishwashing room: Extension of soiled dish table through wall, with raised rim on dining area side so that spillage will not drip on floor. Height of sill about 36 in. above finished floor level (approximately 1 in. higher than working level of dish tables and dishwashing machine). Height of opening only about 18 in. to reduce transmission of noise and conceal unattractive appearance of soiled dish table. Length of opening not less than 24 in., preferably 54 in. so two rows of students can deposit trays or dishes simultaneously. Opening suited to size of equipment if conveyor mechanism is used to bring soiled dishes from dining area.

Lighting and wiring: Comply with National Electrical Code requirements (an American Standard) together with other local requirements. Both natural and artificial lighting desirable. Avoid glare; employees should not work in own shadow. Artificial lighting, incandescent or fluorescent. Fifty foot-candles on all work surfaces; normally achieved by about 5 watts per sq. ft. of floor area.

Plumbing: Cold and hot water connections; 180°F. water for final rinse; about 20 to 25 pounds water flow pressure; provide flow control valve in line to final rinse near dishwashing machine and install a line strainer before the valve. Grease trap, floor drains, and other special connections according to local plumbing code. Water softening equipment may reduce operating costs in some localities.

Ventilation: Mechanical ventilation separate from that of school system. Direct flue connection from dishwashing machine usually more effective than vented hood. Exhaust fan desirable. Free circulation of air at workers' level. If natural ventilation, cross draft is desirable.

#### EQUIPMENT:

Trend - to plan a recessed dish return with two doors (entrance and exit) by which students may return soiled trays and dishes to dishwashing rooms. All returns would take place in dishwashing area not seen from the dining area.

Dish return belts are being planned into newly constructed school lunch units.

Soiled dish table: Stainless steel top; 24 in. to 36 in. wide; tubular legs of galvanized pipe or stainless steel; adjustable stainless steel feet; tubular cross rails at least 8 in. above floor. Shelf underneath for storage of dish racks. Proper drainage of table top essential to prevent waste water from



entering dishwashing sink or machine; may be accomplished by recessed drain or pre-wash unit. Length as needed to provide space for scrapping and pre-washing of dishes.

Pre-wash unit: Dishes pre-washed under water spray to remove all food particles; may be flushed individually before placing in dish rack, or placed in rack after scrapping food waste, then flushed over sink or recessed drain in soiled dish table by overhead spray on flexible mounting controlled by foot pedal or self-closing hand valve; strainers and traps for salvaging lost silverware. Provide 22 in. minimum table top space between pre-wash unit and dishwashing machine to accommodate dish rack.

Disposers, food waste: Electrically driven machines designed to pulverize food wastes so product will be completely water-borne to public sanitary disposal plant. Install in conjunction with pre-wash unit. (optional) Consult State and local sanitation and plumbing codes regarding installation.

Dishwashing sink: Stainless steel; three or more compartments desirable; each compartment 18 to 24 in. wide, 18 to 24 in. front-to-back, and 12 to 14 in. deep, inside measurements. (Size and number of compartments depend on State and local regulations). Sink bottom at least 24 in. above floor; front rim 36 to 38 in. above floor. Sanitary inside corners, coved; integral channel or rolled front and exposed end rims; integral splashboard on rear, 10 to 15 in. high, turned back 2 in. top and sides to conceal water supply pipes; combination mixing faucets with swing-spout to reach each compartment. Sink bottom sloped to drain through removable stainless steel strainer into waste. Exterior-operated lever waste control desirable. Provide drainboard or table surfaces at each end of sink, with rims and splashboard matching sink. Mount entire fixture on metal sanitary legs or concealed wall hangers. Provide institutional type thermometer with adjustable clip to fasten on sink; stainless steel frame; approximately 16 in. long; minimum temperature range, minus 60°F. to plus 360°F. Thermostatically controlled booster heater or auxiliary heating cycle such as side-arm heater needed for 180° F. rinse water in last compartment of sink.

Dishwashing machines: Single-track, stationary rack, door type; Stainless steel; either straight-through or corner type; manually operated sliding doors or rolling hoods; pre-flushed racked dishes pushed through machine by hand; 140° F. wash water containing detergent recirculated through spray nozzles above and below racked dishes. Fresh 180° F. rinse water with timer control, provided from above and below by separate set of spray nozzles. Thermometers to indicate temperature of wash and rinse water. Booster heater or auxiliary heating cycle needed for final 180° F. rinse water at 1½ gallons per 20 by 20 in. rack; 15-lb. flow pressure. Auxiliary equipment available from detergent manufacturer: Detergent feeder, wetting agent injector in



final rinse water. Various types of detergents available for china, plastic and other materials. Adequate for school serving from 100 to 350 lunches daily.

Single-tank rack conveyor type: Stainless steel; open ends with waterproof curtains, pre-flushed racked dishes carried through machine by timed automatic conveyor; 140°F. wash water containing detergent recirculated by motor-driven pump through spray nozzles above and below racked dishes; fresh 180° F. rinse water provided from above and below by separate set of spray nozzles. Thermometers to indicate temperatures of wash and rinse water. Booster heater or auxiliary heating cycle needed for final 180° F. rinse water in amounts specified by State and local authorities, generally 6 gallons per minute at not less than 15-lb. flow pressure. Optional features: inspection and clean-out doors on front; plastic-coated racks; stainless steel frame and enclosing panels for base of machine. Auxiliary equipment available from detergent manufacturer: Detergent feeder; wetting agent injector in final rinse water. Various types of detergents available for china, plastic, and other materials. Adequate for schools serving from 200 to 500 lunches daily.

Two-tank conveyor type: Stainless steel; open ends with waterproof curtains; pre-flushed racked dishes carried through machine by timed automatic conveyor; 140°F. wash water containing detergent recirculated by motor-driven pump through spray nozzles above and below racked dishes in first (wash) compartment. Pumped rinse water recirculated at 170° F. exposing 20 by 20 in. rack to 11½ gallons or recirculated rinse water at not less than 15-lb. flow pressure. Final fresh water rinse, 180° F. from nozzles above and below dish rack in three wide streams full width of rack; 4 gallons per minute at not less than 15-lb. flow pressure. Thermostatically-controlled temperatures, with indicating thermometers for each washing cycle. Booster heater or auxiliary heating cycle needed for final 180° F. rinse water, 4 gallons per minute at not less than 15-lb. flow pressure. Auxiliary features: Selection of left or right hand feed; inspection and cleanout doors on front; detergent feeder and wetting agent injector in final rinse water. Various types of detergents for china, plastic, and other materials available from detergent manufacturer. Adequate for schools serving from 350 to 750 lunches daily.

Dish trucks: For transporting clean dishes to serving area and for storing dishes under serving counter where shelves are not provided. Stainless steel; rubber-tired ball bearing wheels; rubber bumpers; two swivel and two rigid wheels preferable or four swivel wheels if desired. Size and number will vary depending on use. Utility trucks listed in other areas may be utilized in this area; if used for dish storage number will need to be increased.

Garbage cans and covers: Galvanized; 15- to 25-gallon; available with or without casters, or may be used on dollies. Number will vary with method of scrapping -- whether or not waste food and paper are separated, and whether or not a food waste disposer and incinerator are used.

Rubber gloves: As needed.

Brushes: Pot brush: Stiff bristle. Available with short or long handle and with different fibers. Brush face, approximately 5 by 6 in.

Wire brush: Fine steel bristle; approximately 8 by 2 in.

TOTAL LUNCHES SERVED DAILY

100 - 200	200 - 350	350 - 500	500 - 750
1 - 2	1 - 2	2 - 3	3 - 4

Scrapers: For use in scrapping soiled dishes. Flexible nonmetallic blade; approximately 4 to 6 in. wide

TOTAL LUNCHES SERVED DAILY

100 - 200	200 - 350	350 - 500	500 - 750
2 - 3	2 - 3	3 - 4	4 - 5

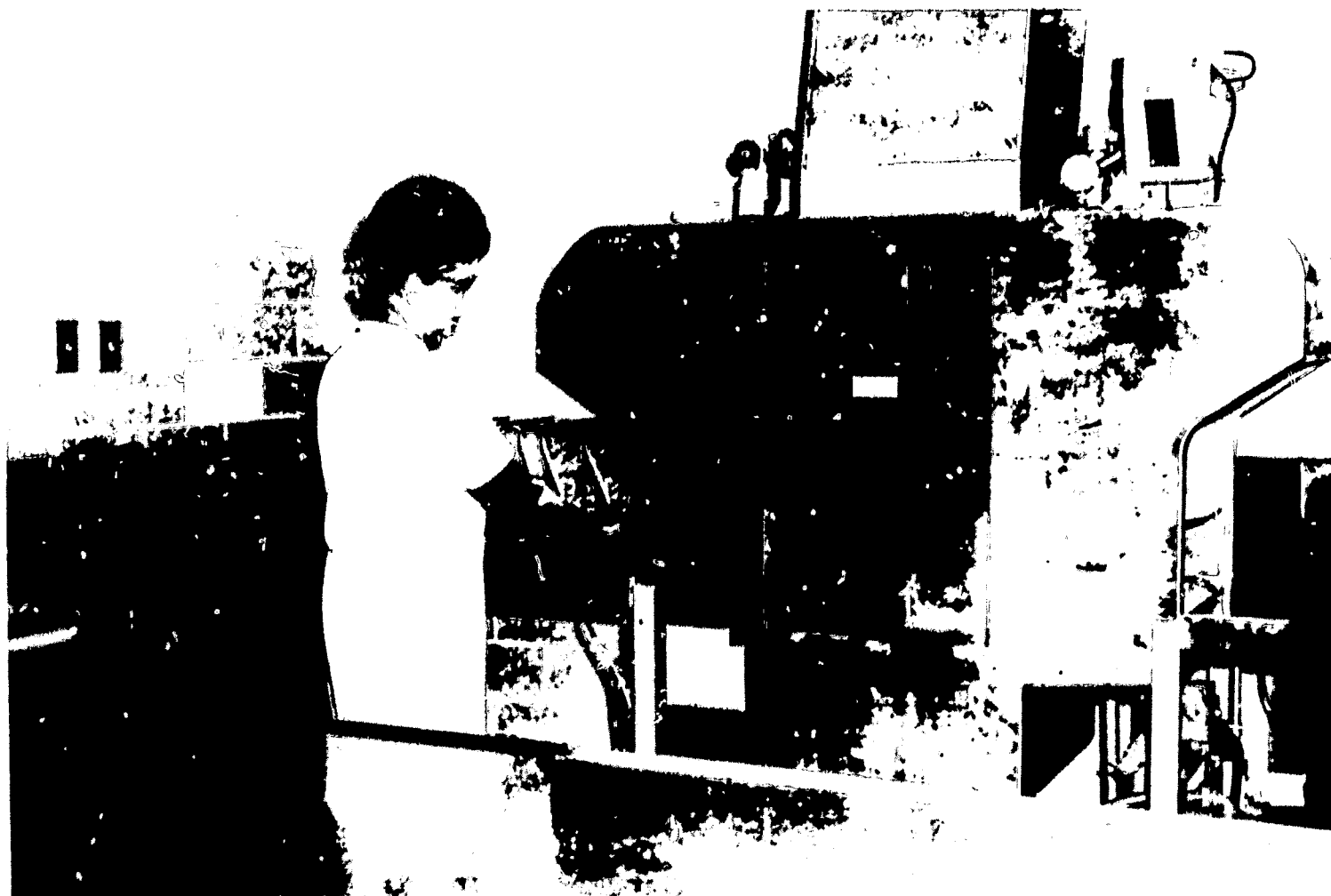

View of dishwashing area showing dishwashing machine.

## DINING AREA

### PURPOSE:

To provide for the child such school lunchroom facilities as are necessary to create and develop an appreciation for a quiet, clean, happy and peaceful environment while eating and to provide through the eating of food, a learning situation by which the child gains educational and social experience. It is an established fact that the equipment and furnishings provided dining areas helps materially to create the atmosphere and beauty that has much to do with the happiness, satisfaction, and participation of children of all grade levels.



View of a high school dining area showing good lighting, screened serving and dish return areas, and tables of varied sizes and shapes, creating a delightful atmosphere in which to enjoy lunch.

### LOCATION:

Adjacent to kitchen and serving areas. Convenient access from outside and from school corridors. Note: Some school systems are successfully operating portable serving equipment which is brought from kitchens to small dining rooms located near classrooms, or directly into classrooms where children are served their meals. The exits from the dining area should be so located that the children leaving the dining room after depositing their soiled dishes do not cross traffic lines coming in to be served.

**SPACE:**

Approximately 10 to 12 sq. ft. floor area per person seated at one time. From 18" to 24" linear table space should be provided for each person served. If multipurpose room, add areas required for uses other than dining. Rectangular room generally more adaptable to seating arrangements. Gymnasium not desirable for daily lunchroom use. (See Table 2, page 40).

**CONSTRUCTION  
FEATURES:**

Consult State and local authorities having jurisdiction over applicable regulations.

Floor: Slip-resistant; quarry tile, terrazzo, or resilient grease-proof flooring desirable. Hard maple or oak flooring satisfactory when properly maintained and installed. Plain smooth concrete with integral hardener acceptable if integral coloring pigment also added to floor. Coved bases at walls essential for cleanliness.

Doors: Not less than 36 in. wide for one-way traffic; 60 in. wide for two-way traffic. Locate for orderly travel of students from serving area to dining tables, and from tables to dish scrapping area, then to exits. Check local regulations for required fire exits, screened openings, fly and other pest controls. Doors to serving and kitchen areas need sound-proofing if dining area is multipurpose type. Provide means of locking kitchen and serving areas from dining area.

Windows: Same sizes and openable areas as required for school classrooms. All openings screened with non-corrodible materials; sturdy latches on screens and sash. Consider use of blinds, shades, draperies or curtains.

Ventilation: Natural or mechanical, same as school classrooms. Cross-ventilation or exhaust fan desirable in warm climate.

Lighting and wiring: Comply with National Electrical Code requirements (an American Standard) together with other local requirements. Both natural and artificial lighting desirable. Avoid glare; provide lighting same as in classrooms if for multipurpose room use. Minimum 15 ft.-candles; normally achieved by about 2 watts per sq. ft. of floor area. Other electric outlets may be required for fans, drinking fountains, and portable serving units.

Walls: Light in color, smooth, impervious to moisture, easy to wash and keep in good repair. Glazed tile easiest to maintain; washable paper or paint on hard plaster satisfactory; exposed painted masonry block units with rough surface texture acceptable for upper wall surfaces above tile or plastic wainscoting. Wood and plasterboard surfaces not rodent-proof; most difficult to maintain, easily damaged, and require frequent painting.



Ceiling: Light in color, smooth, impervious to moisture, easy to wash and keep in good repair. Non-absorbent, rodent-proof, fire-resistant, acoustical type desirable. May be prefabricated acoustical units on mechanical suspension system or painted acoustical plaster on metal lath. Exposed concrete or painted hard plaster less desirable, but acceptable.

Plumbing: Water and drainage connections for drinking fountains.

Heating: Automatic heating system; same temperature control as school classrooms, but valved separately to permit independent operation.

Other considerations: Select harmonious colors and materials for attractive appearance of room. Avoid exposed conduits, pipes, and other surfaces difficult to decorate or keep clean. If multipurpose room, provide adequate storage adjacent to dining area for equipment, tables, etc.



EQUIPMENT:

TOTAL LUNCHESES SERVED DAILY

Tables: Elementary; wood or metal; tops, heat-and stain-proof, for seating 4, 6 or 8 pupils; self-leveling device is desirable; 23, 26 or 29 in. high available. Folding or in-wall tables may be desirable for multi-purpose use; dollies for moving folding tables from multipurpose room.

Tables: Secondary; it is recommended that tables of varied sizes and shapes (round, square, oblong) with varied seating capacity and of colors that enhance the color scheme of the school and dining area be provided for junior and senior high schools. Counter space with stools is also a factor to be considered for secondary schools.

Chairs: Wood or metal; 11 in., 13 in., 15 in., or 17 in. high available. Use with tables approximately 12 inches higher than chair seat. Approximately 4½ to 6 in. knee space; posture chairs with rubber bumpers; shelf underneath, optional. Folding posture chairs may be desirable for multipurpose use; portable racks for chair storage. Use of separate chairs (selection of colors to harmonize with tables) helps greatly to create a pleasant atmosphere within the lunchroom.

Racks and shelves: For coats and books.

Water fountain: Protected angle-jet type; approximately 24 in. high for primary grades; 36 in. high for others. Electric cooling, optional.

100 - 200	200 - 350	350 - 500	500 - 750
Allow approx. 24 in. of space at table edge for each pupil seated. For example, 72 in. by 30 in. table will seat 6 pupils; a 96 in. by 30 in. table will seat 8 pupils; no seating at ends. Use table height appropriate for age level patronizing lunchroom.			
(Same as elementary schools).			
One per person for largest serving period. Use chair height appropriate for age level patronizing the lunchroom.			
As needed.		As needed.	
Optional.		Optional.	
(Locate near exits).			

## PREVENTIVE MAINTENANCE OF FOOD SERVICE EQUIPMENT

The capital investment in kitchen equipment by food service organizations will run into many thousands of dollars which should be protected for a long and efficient life. Dependence on such equipment for daily production and income is vital to a successful operation. Malfunction of equipment will prove costly in wasted food and supplies as well as reducing the operating efficiency of the workers.

A program of scheduled inspections and regular preventive maintenance services can provide assurance of dependable, efficient, a less costly operation of the equipment.

Preventive maintenance is a system of regular service procedures and scheduled inspection of equipment to keep it in good condition by remedying deficiencies before they result in a breakdown.

It is recommended that the food service personnel be trained in the use of equipment and with the proper methods of operation, inspection and preventive maintenance. Their job description should include the cleaning and maintenance of the equipment they are operating. They should inspect equipment for such things as loose brackets, valves, steam, gas and electrical connections of unusual sound of a motor and report it to the person in charge of technical functioning of the equipment.

A good preventive maintenance program is built on cleanliness. Dirt is a menace to the foods handled in the kitchen or service area and is also the enemy of the mechanical parts of the equipment used in the preparation of food.

Instruction sheets with information furnished by the manufacturer should be posted by each piece of equipment.

SUMMARY OF SPACE RECOMMENDATIONS FOR SCHOOL LUNCHROOM AREAS

TOTAL LUNCHESES SERVED DAILY

Area	Page No.	100 - 200		200 - 350		350 - 500		500 - 750	
		Min. sq. ft.	Max. sq. ft.	Min. sq. ft.	Max. sq. ft.	Min. sq. ft.	Max. sq. ft.	Min. sq. ft.	Max. sq. ft.
Receiving Area: Loading platform Receiving area inside bldg.	8-11	60	60	60	60	80	100	100	160
		32	48	48	60	48	60	60	80
Dry food storage area	12-14	50	100	100	175	175	250	250	375
Nonfood storage area	15-16	15	24	30	40	40	60	60	80
Maintenance area: Garbage area Trash area Mop area	17-20	30	48	30	48	48	60	60	75
		--	--	--	--	20	30	30	40
		24	24	24	24	30	40	30	40
Office area	21-22	48	60	48	60	48	60	48	60
Locker & toilet area for employees	23-25	33	33	48	48	60	60	76	76
Kitchen area	26-29	200	500	400	875	700	1250	1000	1875
Serving area	52-57	100	200	200	350	350	500	500	750
Dishwashing area	58-62	60	180	105	180	105	210	180	210
Total kitchen & service areas		652	1277	1093	1920	1704	2680	2394	3821
Dining area, based on 2 seatings daily	63-66	500	1200	1000	2100	1750	3000	2500	4500
Gross recommended areas		1152	2477	2093	4020	3454	5680	4894	8321
Area per lunch served		11.5	12.4	10.5	11.5	9.9	11.4	9.8	11.1

## ENGINEERING ABBREVIATIONS

C.W.	Cold Water	KW	Kilowatt
H.W.	Hot Water		Motor
H.H.	Hot Water 180°	G	Gas
O	Open	O.D.	Outside Dimension
C	Closed	P.S.I.	Pressure per sq. in. (Dishwasher-Steamer)
SS	Steam Supply	I.P.S.	Internal Pipe Size
S.R.	Steam Return	I.P.T.	Internal Pipe Thread

## ARCHITECTURAL SYMBOLS

Plumbing Symbols (American Standards Association - gives approval ratings in the area of plumbing, designations: Am. Standard)

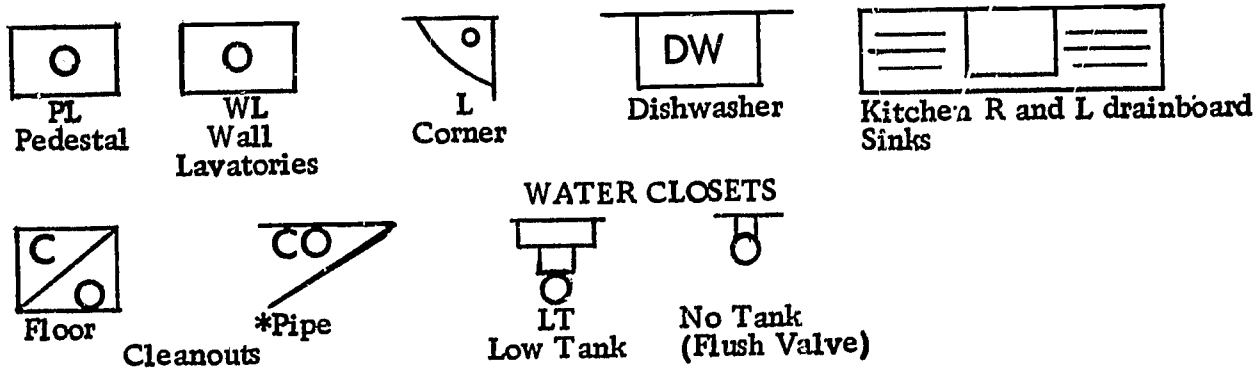

"Plumbing Code" - American Standard Association  
 "The Ideal Filter" - American Radiator Company

### Piping Symbols

Soil, Waste or leader \_\_\_\_\_  
 (above grade)

Soil, Waste, or leader \_\_\_\_\_  
 (below grade)

Vent . . . . .

Cold H<sub>2</sub>O \_\_\_\_\_

Hot H<sub>2</sub>O \_\_\_\_\_

Hot H<sub>2</sub>O Return \_\_\_\_\_















Fire Line \_\_\_\_\_ F \_\_\_\_\_ F \_\_\_\_\_ F \_\_\_\_\_ F \_\_\_\_\_

Gas \_\_\_\_\_ G \_\_\_\_\_ G \_\_\_\_\_ G \_\_\_\_\_ G \_\_\_\_\_



## Electrical Symbols

### General Outlets



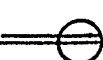
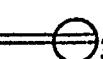
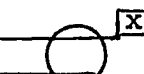

#### Ceiling Wall

		Outlet
		Electrical
		Fan
		Junction Box
		Lamp Holder
		Pull Switch Specify Voltage
		Clock Outlet







### Convenience Outlets

	Double
	1-Single
	Triplex
	Range Outlet
	Special Purpose Description in Specification
	Floor Outlet







### Auxiliary Systems

	Push Button
	Bell
	Elec. door opener
	Buzzer
	Outside Telephone

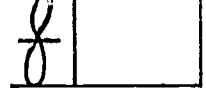

### Panels - Circuits, etc.

	Lighting Panel
	Power Panel
	Generator
	Motor
	Instrument Panel
	Power Transformer

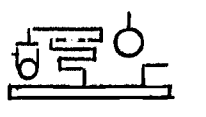
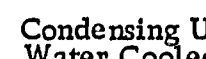
### Refrigerating Symbols

	Gage
	Thermostat Self-contained
	Thermostat (Remote Bulb)
	Thermostat (Remote Bulb)
	Finned type Cooling Unit, Natural Connec.
	Forced Connection, Cooling Unit
	Compressor
	Condensing Unit, air cooled
	Condensing Unit, Water Cooled

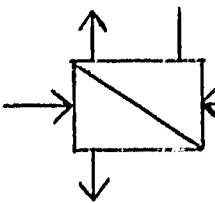
### Heat-Power Apparatus Symbols

	Steam Generator (Boiler)
	Line Steam Superheater
	Automatic Reducing Valve
	Steam Trap



# SCALE TEMPLATES OF KITCHEN EQUIPMENT

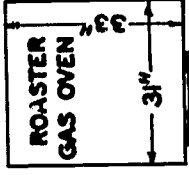
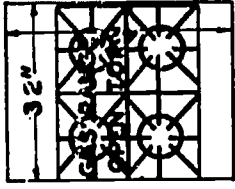
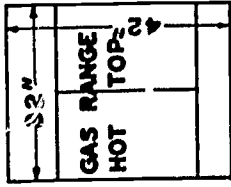
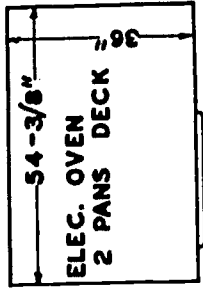
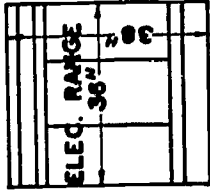
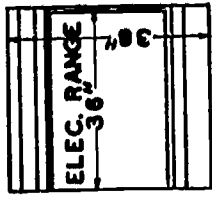

## ELECTRIC COOKING EQUIPMENT

## GAS COOKING EQUIPMENT

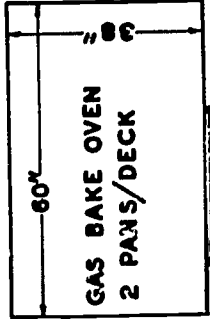
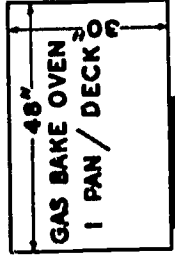
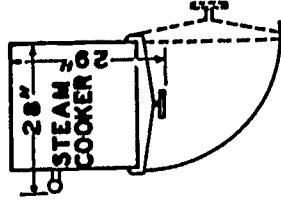
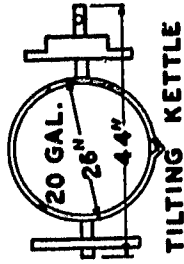
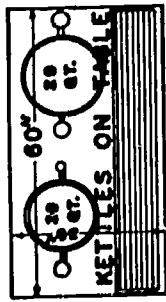

## STEAM COOKING EQUIPMENT

## TILTING KETTLE

## FRYERS

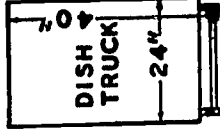
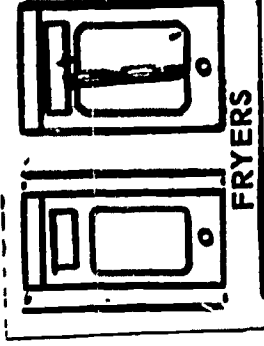
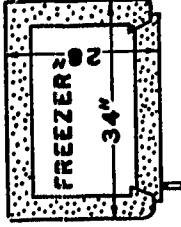
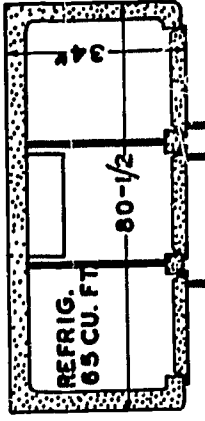
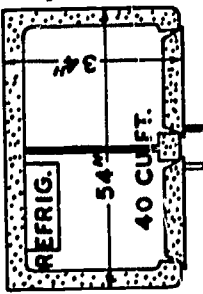
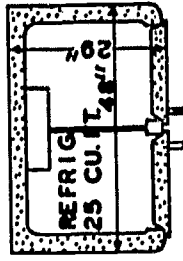

## PORTABLE REACH-IN. REFRIGERATORS & CABINETS

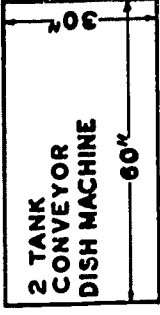
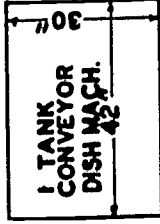
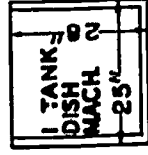
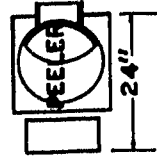
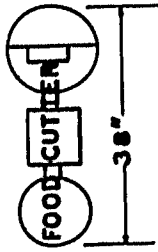
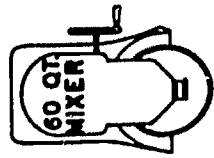

## KITCHEN MACHINES

# SCALE TEMPLATES OF KITCHEN EQUIPMENT

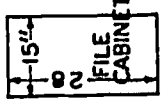
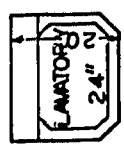
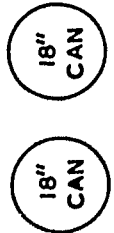
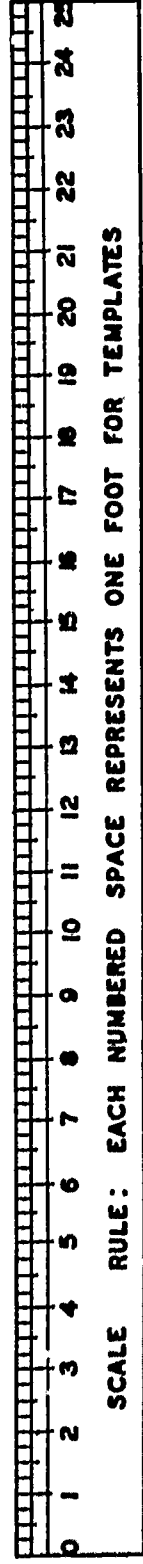
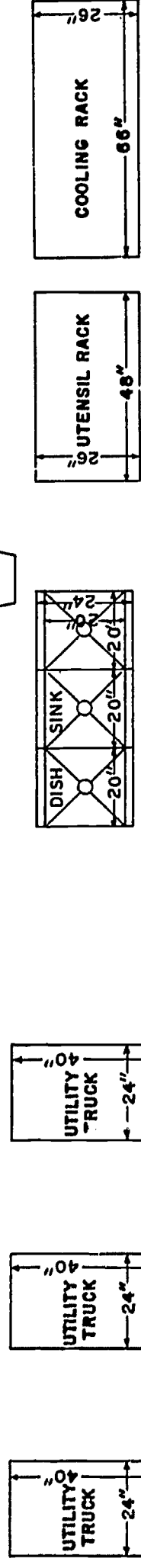
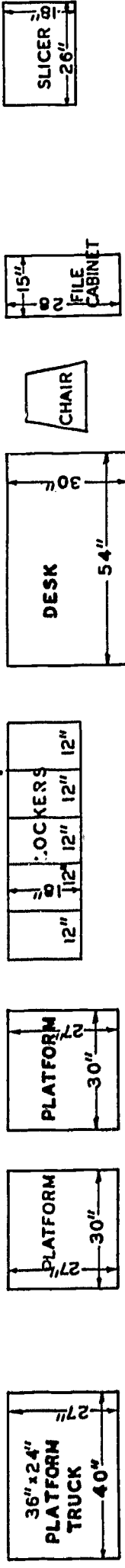
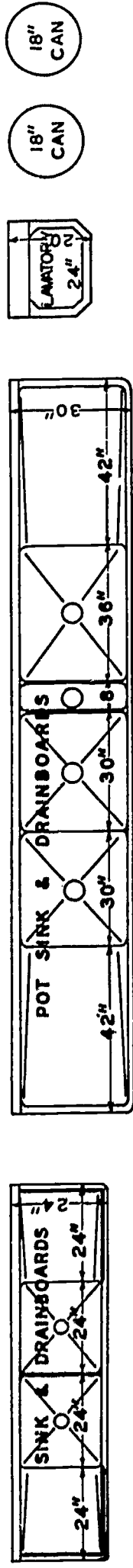
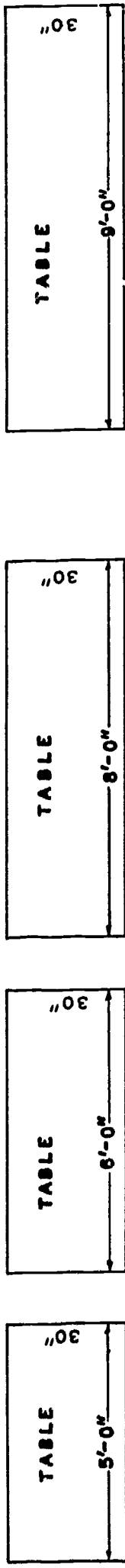
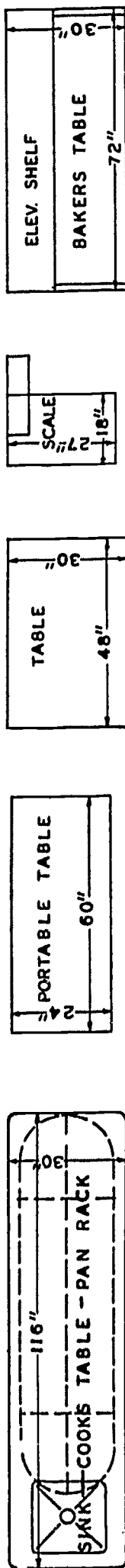

## BIBLIOGRAPHY

1. West, Bessie Brooks, Wood, Levelle, Harger, Virginia. "Food Service in Institutions." (Fourth edition).
2. Stokes, John W. "Food Service in Industry and Institutions."
3. Kotschevar, Terrell. "Food Service Planning, Layout and Equipment."
4. "Guidelines for Dietitians and Food Service Supervisors." American Gas Association, Inc.
5. "Fact Book of Commercial Electric Kitchen Equipment." Food Service Magazine, 1966-67.
6. "Work Design, Equipment and Layout," Selected papers from Food Administration Conference, Institution Management Department, Iowa State University of Science and Technology.
7. "Selecting, Arranging and Using Facilities for School Lunch Programs," Experiment Station, College of Agriculture, University of Wisconsin.
8. "The Planning of School Food Service Facilities," School Plant Planning Series, Utah State Board of Education, 1956. (process of revision).
9. "A Guide for Planning and Equipping School Lunchrooms," United States Department of Agriculture, Agricultural Marketing Service, PA 292.
10. "Layout, Equipment, and Work Methods for School Lunch Kitchens and Serving Lines," Marketing Research Report No. 753, Agricultural Research Service, United States Department of Agriculture.
11. "Look at the School Lunch Storeroom," United States Department of Agriculture, Production and Marketing Administration.
12. "Specifications for Shelves and Floor Racks for the School Lunch Storeroom," United States Department of Agriculture, Production and Marketing Administration, PA 133.
13. Current equipment catalogs, courtesy equipment companies.
14. Cronan, Marion, "The School Lunch."
15. Bryan, Mary de Garmo Bryan, "The School Cafeteria." (Second edition).
16. Ramsey, Sleeper, "Architectural Graphic Standards." John Wiley & Sons, New York, 1962. (Fifth edition).
17. Plumbing Code, American Standard Association.
18. "The Ideal Filter," American Radiator Company.
19. Ramsey, Sleeper, "Architectural Graphic Standards," John Wiley & Sons, New York. (Seventh edition).