

D O C U M E N T R E S U M E

ED 022 329

EF 001 568

PHYSICAL FACILITIES INVENTORY BY BUILDING AND ROOM. INSTRUCTION MANUAL, 2ND EDITION.

Pennsylvania State Dept. of Public Instruction, Harrisburg.

Pub Date Jan 68

Note- 125p.

EDRS Price MF-\$0.50 HC-\$5.08

Descriptors-ADMINISTRATIVE PERSONNEL, BUILDINGS, CLASSIFICATION, CLASSROOMS, CODIFICATION, COLLEGE PLANNING, DATA ANALYSIS, DATA COLLECTION, DATA SHEETS, *FACILITY INVENTORY, *HIGHER EDUCATION, *MANUALS, MASTER PLANS, *METHODS, PUBLIC FACILITIES, STANDARDS

Identifiers-Harrisburg, Pennsylvania

To provide a basis on which to determine space required in the public higher education institutions of Pennsylvania, the State Commission on Academic Facilities developed an instruction manual for a method of inventorying physical facilities by building and room. The building inventory and the room inventory are presented as separate sections, each section providing the necessary procedures to be followed and the data forms to be used. General information is provided on the scope of the inventory, the building identification coding, an inventory of residential facilities and the staff required for an inventory study. Appendixes provide necessary data for completing the forms and include such items as building categories and codes, construction codes, building condition codes, determining the gross building area, ownership codes, room function codes and definitions, room type codes, and other information related to building and room classifications. (BH)

Commonwealth Of Pennsylvania
Higher Education Facilities
Comprehensive Planning

PHYSICAL FACILITIES INVENTORY
BY BUILDING AND ROOM

INSTRUCTION MANUAL

SECOND EDITION

U.S. DEPARTMENT OF HEALTH, EDUCATION & WELFARE
OFFICE OF EDUCATION

THIS DOCUMENT HAS BEEN REPRODUCED EXACTLY AS RECEIVED FROM THE
PERSON OR ORGANIZATION ORIGINATING IT. POINTS OF VIEW OR OPINIONS
STATED DO NOT NECESSARILY REPRESENT OFFICIAL OFFICE OF EDUCATION
POSITION OR POLICY.

State Commission On Academic Facilities
Department Of Public Instruction
Box 911
Harrisburg, Pennsylvania 17126

ED022329

ED022329

EF 001568

Commonwealth Of Pennsylvania
Higher Education Facilities
Comprehensive Planning

PHYSICAL FACILITIES INVENTORY
BY BUILDING AND ROOM.

INSTRUCTION MANUAL.

Second Edition
January 1968

State Commission On Academic Facilities
Department Of Public Instruction
Box 911
Harrisburg, Pennsylvania 17126

ACKNOWLEDGEMENTS

The Higher Education Facilities Comprehensive Planning study is being conducted under the auspices of the State Commission on Academic Facilities. The study has been approved by the United States Commissioner of Education and is financed by a grant from the Office of Education.

STATE COMMISSION ON ACADEMIC FACILITIES

Dr. Leonard N. Wolf
Chairman, Biology Department
University of Scranton

Dr. David H. Kurtzman
Superintendent of Public
Instruction

James H. Rowland, Esq.,
Vice Chairman
812 North 17th Street
Harrisburg, Pennsylvania

Dr. Katherine E. McBride
President
Bryn Mawr College

Frank N. Hawkins
Editor
Pittsburgh Post-Gazette

John H. McNally
Secretary
State Commission

ADVISORY COMMITTEE

Dr. Leroy B. Allen
President
Cheyney State College

Dr. Carl A. Hanson
President
Gettysburg College

Dr. Paul R. Anderson
President
Temple University

Dr. Paul Swain Havens
President
Wilson College

Brother Daniel Bernian, F.S.C.
President
La Salle College

Dr. Ralph E. Heiges
President
Shippensburg State College

Bruce E. Cooper, Esq.
Chairman, Board of Trustees
Harrisburg Area Community College

Dr. Putnam F. Jones
Dean of the Graduate Faculty
University of Pittsburgh

ADVISORY COMMITTEE (Cont'd)

Dr. Robert J. Kibbee
Asst. to the President for Planning
Carnegie-Mellon University

Dr. Ray A. Miller
President
York Junior College

Dr. James D. Lawson
President
Butler County Community College

Dr. Lawrence L. Pelletier
President
Allegheny College

Dr. W. Deming Lewis
President
Lehigh University

Dr. J. R. Rackley
Provost
Pennsylvania State University

Very Rev. Henry J. McAnulty, C.S.Sp.
President
Duquesne University

Sister M. Camillus Scully, RSM
President
Mount Mercy College

Counsel and professional staff assistance provided by the consulting firm
of Cresap, McCormick and Paget.

Commonwealth Of Pennsylvania
Higher Education Facilities
Comprehensive Planning

PHYSICAL FACILITIES INVENTORY
BY BUILDING AND ROOM

INSTRUCTION MANUAL

TABLE OF CONTENTS

Section

ACKNOWLEDGEMENTS

- I GENERAL INFORMATION
- II PROCEDURES FOR THE COMPLETION OF THE
INSTITUTIONAL BUILDING INVENTORY
- III PROCEDURES FOR THE COMPLETION OF THE
INSTITUTIONAL ROOM INVENTORY BY BUILDING

APPENDIXES -

- A - Building Function Categories, Codes And Definitions
- B - Building Construction Type Codes
- C - Building Condition Codes
- D - Determination Of Gross Building Area
- E - Ownership Codes
- F - Source Of Funds Codes
- G - Room Function Codes And Definitions
- H - Type Of Room Codes And Definitions
- I - Room Condition Codes
- J - Procedures For Calculating Assignable Areas In
Square Feet
- K - Type Of Student Station Code

SECTION I

GENERAL INFORMATION

Instruction Manual Arrangement

The physical facilities inventory consists of two major phases: (1) the building inventory and (2) the room inventory. Sections II and III of the instruction manual discuss these phases. Each section details the procedure to be followed in the completion of all entries on each inventory document. The two inventory documents to be used in reporting facilities information are included as Exhibit A to Section II and Exhibit A to Section III. Necessary definitions and illustrations are provided in the procedures for each document and in the appendixes following Section III.

Scope Of Inventory

The inventory includes all existing facilities, those which are planned and funded (excluding facilities which are planned but not funded) and those under construction. Appropriate building condition codes for these categories are provided in Appendix C. The data are requested to reflect conditions on each campus as of January 1, 1968.

Buildings Excluded From The Inventory

Do not report data for the following types of buildings:

1. Investment properties.
2. Buildings located on remote Institutional property and used by only a small percentage of the student body on an irregular basis for short periods of time. Such facilities may include farms, ranches, mountain retreats, and field camps.
3. Federal contract research centers.
4. Hospitals not owned by the Institution, although limited research and/or instruction may be conducted in them.
5. Public schools, not owned by the Institution, but which are used for practice teaching.

6. Branch campuses, extension centers and components of the Institution which are located outside the United States.

Note: Circulation Area (such as hallways, elevators and stairways) and custodial closets which do not service a particular room are NOT assignable areas and these areas are NOT to be inventoried.

Building Identification Number

Prior to beginning the building and room inventories, a three-digit identification code must be assigned by the Institution to each of its buildings. This number serves no other purpose than to identify each building. (Use of this number for sorting buildings to alphabetical order, for example, is not recommended since necessary revisions to the numbers complicates the historical stability of the record system.) This same three-digit number must be entered on the Institutional Room Inventory Document for each building. Neither alphabetic nor alpha-numeric coding should be used.

Inventory Of Residential Facilities

The physical facilities inventory will include all Institutionally owned, leased or financially controlled dormitories, fraternity and sorority houses and all privately owned dormitories currently housing Institutional resident students. Privately owned dormitories will be assigned the ownership Code 3 shown in Appendix E. Privately owned fraternity and sorority houses, boarding houses and apartments are not included in the inventory.

Students residing in privately owned fraternity and sorority houses, boarding homes and apartment houses will be classified as nonresident students in residential facilities projections.

Students residing in Institutionally owned, leased or financially controlled facilities and students in privately owned dormitories are defined as resident students in residential facilities projections.

Fraternity houses are coded as building functional type 70600 and sorority houses are coded as building functional type 70700 on Pages A-3 and A-7 of Appendix A. Residence rooms within fraternity and sorority houses are coded, 901-Single, Men's Residence on Page H-57 and 910-Single Women's Residence on Page H-58. Kitchen, recreation and service areas are assigned the appropriate codes found on Pages H-57 through H-64.

Note: Complete only the building document for Institutionally owned faculty and administrative staff housing. Do not complete a room inventory of these facilities. Use categories 940-943 to record data for residence facilities currently being used by sorority, fraternity and dormitory house mothers, or proctors who live in the student facility but who are considered by the Institution to be staff members and not students. Residence facilities currently used by student advisors or proctors, graduate or undergraduate, should be inventoried as student residence facilities.

When inventorying Institutionally owned married student apartment housing, enter the Institutional building number in the space provided on the room document and enter the apartment number in columns 10-14, following the procedures for the entry of a room number. Enter the total net assignable square feet to the nearest square foot for the entire apartment in columns 22-27. Do not report each room of the apartment individually.

Institutional Inventory Staff

Three persons are vital to the successful completion of the physical facilities inventory. They are the person designated as the Institution's study coordinator, the Institution's business officer, and the person designated as Facilities Recorder. The responsibilities and qualifications of each are:

The Institutional Study Coordinator is appointed by the Institution to coordinate the efforts of all Facilities Recorders and the Business Officer in the completion of the inventory documents. He should ensure that all facilities have been inventoried, and that all inventory documents are completed and returned to him.

During the inventory the Study Coordinator will provide liaison between the Institution and Mr. Keith Gentzler, Comprehensive Program Planning Director, Bureau of Higher Education Facilities, Department of Public Instruction, Education Building, Harrisburg; phone: (717) 787-2057. All inquiries and recommendations regarding the Institution's participation in the study should be directed through the Institutional Study Coordinator.

When all inventory documents have been completed, the Institutional Study Coordinator should forward all completed documents to The State Commission on Academic Facilities c/o Mr. Gentzler.

The Institutional Business Officer should be responsible for the completion of all entries on the Building Inventory Document which are designated for him in the procedures accompanying the document. The Business Officer completing the document should have a knowledge of and access to the Institution's building financial data and be familiar with the appropriate methods of calculating the required entries.

The Facilities Recorder should be appointed by the Institutional Study Coordinator. He would have responsibility for the completion of those entries on the building inventory which are specified for him in the procedure accompanying the Building Inventory Document, and for the completion of the Room Inventory Document.

The Recorder should inspect each building and room assigned to him and complete all required entries, carefully following the procedures provided for each entry.

Familiarity with the Institution's facilities and a working knowledge of simple mathematics and measuring techniques for computing the gross and assignable areas are desirable qualifications for this assignment. Individuals with mathematical or engineering backgrounds would be especially qualified for the position.

SECTION II

PROCEDURES FOR THE COMPLETION OF THE INSTITUTIONAL BUILDING INVENTORY

| <u>Position Responsible</u> | <u>Instructions For Completion</u> |
|---------------------------------|---|
| BUSINESS OFFICER | <ol style="list-style-type: none">1. Select the first building on campus to be inventoried.2. Refer to Exhibit II-A, following page II-9, for illustration of the required entries.3. Complete "Institutional Building Inventory Document" as follows:<ol style="list-style-type: none">a. Institution Code: Enter the assigned Institution code in the box provided in the upper left corner of the inventory document. For example: |

| |
|---------------------------|
| Institution Code 13200 |
|---------------------------|

- b. Institution Name: Enter the complete name of the Institution in the box entitled "Institution Name."
For example:

| |
|--|
| Institution Name Harrisburg Community College |
|--|

- c. Business Officer: Enter full name in the box entitled "Business Officer" in the upper right hand corner of the document. For example:

| |
|------------------------------------|
| Business Officer D. C. Business |
|------------------------------------|

Position
Responsible

Instructions For Completion

- d. Inventory Date: Enter the current date, in the box entitled "Inventory Date." For example:

| |
|------------------------------------|
| Inventory Date January 17, 1968 |
|------------------------------------|

- e. Page Number: Enter the first page number in the space provided in the upper document. For example:

Sheet 1 of

- f. Building Number: Enter the building identification number, discussed in section I of the manual, in columns 7, 8, and 9. The number assigned to each building must be a unique three digit code. Neither alphabetic nor alpha-numeric coding should be used. The data must be right justified, i. e., the lowest order digit must be entered in column 9. For example, if a building is assigned the identification number 8, the number would be entered as follows:

| NUMBER | | |
|--------|---|---|
| 7 | 8 | 9 |
| | | 8 |

If the high order positions, columns 7 and 8 in this example, are not required, these positions must be filled with a zero (0). The entry for building number 8 would be:

| NUMBER | | |
|--------|---|---|
| 7 | 8 | 9 |
| 0 | 0 | 8 |

Position
Responsible

Instructions For Completion

- g. Abbreviated Building Name: Write the "Abbreviated Building Name" in columns 10-24. The name should be abbreviated in a manner most meaningful to the Institution. If a Mr. John Charles Thomas, for example, had donated funds for the construction of a gymnasium, the building name might be entered as follows:

| ABBREVIATED NAME | | | | | | | | | | | | | | |
|------------------|----|----|----|----|----|----|----|----|----|----|----|----|----|----|
| 10 | 11 | 12 | 13 | 14 | 15 | 16 | 17 | 18 | 19 | 20 | 21 | 22 | 23 | 24 |
| J | C | | T | H | O | M | | M | E | N | | G | Y | M |

Regardless of the manner in which the name is abbreviated, the entry must be left justified, i. e., the first letter of the first word or abbreviation entered must be entered in column 10.

- h. Make no entries in columns 25-33.
- i. Estimated Useful Life: Enter the Institution's estimate of the remaining useful life of the building in years in columns 34 and 35. The data must be right justified, i. e., for a building having an estimated useful life of nine (9) years or less, the appropriate digit must be entered in column 35. The unrequired high order position, column 34 in this example, must be completed with a zero (0). The entry for a building having an estimated useful life of eight (8) years would appear as follows:

| EST'D USEFUL LIFE IN YEARS AT THIS DATE | |
|---|----|
| 34 | 35 |
| 0 | 8 |

- j. Make no entries in columns 36-41.

Position
Responsible

Instructions For Completion

- k. Ownership: Enter the appropriate ownership code for the building in column 42. Refer to Appendix E for the ownership codes.
- l. Year Of Initial Occupancy: Enter the complete year in which the building was first occupied by the Institution in columns 43-46. For example, a building initially occupied in 1965 would require the complete entry 1965.
- m. Total Actual Capital Investment: Enter the total actual capital investment of the building in thousands of dollars to the nearest thousand dollars in columns 47-51. The total plant fund investment for the building should be entered. The figure must include all capitalized building costs, such as additions and capitalized renovations, all capitalized equipment, whether fixed or movable, capitalized architectural and engineering fees, utility connections, capitalized site preparations and improvements, including parking facilities and sidewalks for the building. Enter zeros in columns 47-51 for facilities which are rented by the Institution, to indicate that no capital investment has been made by the Institution. For lease-purchase arrangements, enter the amount of the ultimate capital investment to be made by the Institution through the lease-purchase agreement. The data must be right justified, i. e., the lowest order digit must be entered in column 51. Unrequired high order positions must be completed with a zero (0). For example, the entry for a building having a total actual capital investment of \$3,550,000 would read:

| AMOUNT IN THOUSANDS | | | | |
|---------------------|----|----|----|----|
| 47 | 48 | 49 | 50 | 51 |
| 0 | 3 | 5 | 5 | 0 |

Position
Responsible

Instructions For Completion

- n. Date: Enter the month and year that the actual capital investment was made in columns 52, 53, 54 and 55. If the actual date is unknown, an estimate of the date should be made. The data must be right justified. See the discussions under item f for the definition and illustration of right justified entries.
- o. Furnishings Cost: Enter in columns 56-60 the furnishings cost in thousands of dollars to the nearest thousand dollars for the furnishings which are installed in the building on the date the inventory is taken, i. e., the current furnishings cost. The furnishings may have been replaced or the type of furnishings altered several times since the building was initially occupied. Only the cost of furnishings currently installed in the building should be entered.

In general, furnishings costs include movable equipment (not requiring utility connections, fixed electrical hookup, etc.). Office machines, laboratory supplies (test tubes, chemicals, etc.) and other expendable items are not included. If the furnishings cost for the building has been capitalized this figure will have been included as part of the total actual capital investment of the building and will be a break-out from that total. The data must be right justified. See the discussion under item f for the definition and illustration of right justified entries.

- p. Source Of Funds: Enter the appropriate source of funds code only in column 61 for buildings initially occupied after June 30, 1964. Refer to Appendix F for the source of funds codes. If a building was initially occupied prior to June 30, 1964, column 61 must be completed with a zero.

Position
Responsible

Instructions For Completion

If more than one source of funds contributed to the total capital investment of buildings initially occupied after June 30, 1964, use additional lines below the original entry to indicate each subsequent source. Vertical lines must be shown in all other data fields to indicate that all sources and amounts pertain to the same building. See Exhibit II-A for illustration of these entries.

- q. Amount Of Funds: For each building initially occupied after June 30, 1964, enter in columns 62-66 the amount of funds for each source indicated in column 61. The amount must be entered in thousands of dollars to the nearest thousand dollars. If a building was initially occupied prior to June 30, 1964, columns 62-66 must be completed with zeros.

If more than one source of funds contributed to the total capital investment of the building use additional lines below the original entry to indicate each subsequent amount. Vertical lines must be shown in the remaining data fields to indicate that all sources and amounts pertain to the same building. See Exhibit II-A for illustration of these entries.

- r. Estimated Replacement Value: Enter the estimated replacement value of the building in thousands of dollars to the nearest thousand dollars in columns 67-71. The amount entered must include only the current replacement value of the capitalized investment for the building. Furnishings which would not be capitalized are not to be included as part of the estimated replacement value.

The figure should reflect the current cost to construct a new facility on campus to fulfill the same function currently provided by the existing building. It should not be interpreted to mean the cost of reproducing the building exactly as it now stands.

Position
Responsible

Instructions For Completion

The value may be taken from the full insurable value of the building, recent accurate appraisals, or the current construction cost per square foot for similar types of facilities.

The data must be right justified. See the discussion under item f for the definition and illustration of right justified entries.

4. When the required data has been completed for all buildings in the inventory, enter the total number of pages of building inventory documents completed for the Institution in the space provided in the upper right hand corner of each sheet. For example, if 23 sheets of inventory documents were completed by an Institution, the entry made in item a above would be completed on the first two sheets to read:

Sheet 1 of 23

Sheet 2 of 23

5. Forward all "Institutional Building Inventory Documents" to the Facilities Recorder for completion.

FACILITIES
RECORDER

1. Receive the Building Inventory Document from the Business Officer, review the instructions for the completion of the required entries and refer to Exhibit II-A for illustration of the data entries.
2. Complete the following data entries during a walking audit of all buildings to be inventoried.
 - a. Facilities Recorder: Enters his full name in the box entitled "Facilities Recorder." For example:

| |
|---------------------------------------|
| Facilities Recorder J. O. Recorder |
|---------------------------------------|

Position
Responsible

Instructions For Completion

- b. Functional Type: Determine the building's primary functional type and enter the appropriate building functional type code number in columns 25-29. (Refer to Appendix A for the definition and listing of the building function codes.) It may be helpful to delay the completion of this entry until after the room inventory has been completed. The primary function of a multi-purpose building may be more readily discernable at the conclusion of the room inventory.
- c. Construction Type: Determine the building construction type and enter the appropriate code for the type of construction of the building in column 30. Refer to Appendix B for the building construction type codes.
- d. Number Of Floors: Enter the total number of floors within the building in columns 31-32. The data must be right justified, i. e., for a building have nine (9) floors or less enter the total number of floors in column 32.. The unrequired high order position, column 31 in this example, must be completed with a zero (0); for example:

| NO. OF FLOORS | |
|---------------|----|
| 31 | 32 |
| 0 | 9 |

All floors within a building including basements, all subground floors, and penthouses must be included as floors. Any thirteenth floors must be included in sequential order.

Position
Responsible

Instructions For Completion

INSTITUTIONAL
STUDY
COORDINATOR

- e. Determine the condition of the building and enter the appropriate building condition code in column 33. Refer to Appendix C for the building condition codes.
 - f. Gross Area: Enter the gross area of the building in square feet to the nearest square foot in columns 36-41. The data must be right justified. See the previous discussion under item f for illustration of right justified data. Refer to Appendix D for the definition and method of measurement of gross building area.
3. Return all completed documents to the Institutional Study Coordinator.
 1. Add each returned completed document to the completed documents file.
 2. Return all completed building inventory documents to the Pennsylvania State Commission on Academic Facilities c/o Mr. Gentzler when all facilities on campus have been inventoried, including the room inventory (Section III).

SECTION III

PROCEDURES FOR THE COMPLETION OF THE INSTITUTIONAL ROOM INVENTORY BY BUILDING

| <u>Position Responsible</u> | <u>Instructions For Completion</u> |
|---------------------------------|--|
| FACILITIES RECORDER | <ol style="list-style-type: none">1. Select the first building to be inventoried by room and the first room within that building to be inventoried.2. Refer to Exhibit III-A, following page III-6, for illustration of the required data entries.3. Complete the "Institutional Room Inventory By Building" as follows:<ol style="list-style-type: none">a. Page Number: Enter the first page number in the space provided in the upper right corner of the inventory document. For example:<p style="text-align: center;">Sheet <u> 1 </u> of <u> </u></p>b. Institution Code: Enter the assigned institution code in box provided in the upper left corner of the inventory document. For example:<div style="border: 1px solid black; padding: 5px; width: fit-content; margin: 10px auto;"><p style="text-align: center;">Institution Code 13300</p></div>c. Institution Name: Enter the complete name of the institution in the box entitled "Institution Name." For example:<div style="border: 1px solid black; padding: 5px; width: fit-content; margin: 10px auto;"><p style="text-align: center;">Institution Name Pennsylvania College</p></div>d. Form Prepared By: Enter full name in the box entitled "Form Prepared By." For example:<div style="border: 1px solid black; padding: 5px; width: fit-content; margin: 10px auto;"><p style="text-align: center;">Form Prepared By John Q. Recorder</p></div> |

Position
Responsible

Instructions For Completion

- e. Inventory Date: Enter the current date in the box entitled "Inventory Date." For example:

| |
|------------------------------------|
| Inventory Date January 17, 1968 |
|------------------------------------|

- f. Building Number: Enter the unique building number, assigned by the Institution to each building, in the box provided in the upper right corner of the room inventory document.

The building number must be the same three digit building number entered on the building inventory document. If a building number requires only two digits such as building 27, the unrequired high order position must be completed with a zero (0) as follows:

| |
|------------------------|
| Building Number 027 |
|------------------------|

- g. Room Number: Enter the room number assigned to the first room to be inventoried in columns 10-14. In general, columns 11-13 should be used for a typical three-digit room number. Column 10 should be used for any rooms numbered 1,000 and above. This column may also be used for alphabetic prefixes before they occur. Column 14 should be used for alphabetic suffixes. Columns 10 and 14 should be left blank where prefix and/or suffix do not occur. Columns 11 to 13 should have an entry in each column. For example, the room number 317C would be entered as follows:

| NUMBER | | | | |
|--------|----|----|----|----|
| 10 | 11 | 12 | 13 | 14 |
| | 3 | 1 | 7 | C |

Position
Responsible

Instructions For Completion

Note: If a room is currently unnumbered, a room number must be assigned. The door or doorway of unnumbered rooms must be physically marked for future reference. It is suggested that a card on which the number is written be attached to the door or that the number be written directly on the door or doorway with a marking pen or stencil.

If the inventory is taken from construction drawings or blueprints, the blueprints should be labeled with the room numbers as they are assigned. If building plans or blueprints are used for the inventory, a walking audit of all rooms must be made to ensure the accuracy of the drawings and resulting data.

If the Institution has a class or classes currently meeting on a regular basis in a hallway because of a lack of space of the required dimensions, assign a number to the hall as follows. Assign the prefix H, the suffix L and a number to each area. The code for first hall would be entered as follows:

| NUMBER | | | | |
|--------|----|----|----|----|
| 10 | 11 | 12 | 13 | 14 |
| H | O | O | 1 | L |

Enter zeros for room type in columns 17-19. Calculate the area in square feet currently being used, and enter the figure in columns 22-27. Also enter the number of student stations installed in the area in columns 33-37, and zeros in columns 28-32 if the optimum is felt to be no use of the hall whatever.

- h. Room Function: Enter the appropriate function code in columns 15 and 16. (Refer to Appendix G for the room function codes.)
- i. Room Type: Enter the appropriate type of room codes in columns 17-19. (Refer to Appendix H for the type of room codes.)

Position
Responsible

Instructions For Completion

- j. Condition: Evaluate the condition of the room and enter the appropriate room conditions code in columns 20 and 21. (Refer to Appendix I for the room condition codes.)
- k. Assignable Area: Obtain the dimensions of the room and calculate its assignable area in square feet to the nearest square foot. This value is entered in columns 22-27. The data must be right justified; i. e., the lowest order digit must be entered in column 27. Unrequired high order positions must be completed with a zero (0). For example, for a room having a total assignable area of 2,500 square feet, the entry would be:

| ASSIGNABLE SQUARE FEET | | | | | |
|------------------------|----|----|----|----|----|
| 22 | 23 | 24 | 25 | 26 | 27 |
| 0 | 0 | 2 | 5 | 0 | 0 |

(Refer to Appendix J for the definition and method of calculation of the room assignable area in square feet.)

1. Optimum Student Stations: Estimate the optimum number of student stations for the room and enter this figure in columns 28-32. The estimate of the optimum number of student stations should reflect the Institution's estimate of the maximum operable capacity of the room for each type of installed student station, i. e., the maximum number of student stations which could be installed in a room without impairing efficient operation of the room. This estimate may be greater than, equal to, or less than, the number currently installed. If the Institution feels that the optimum is actually less than the number installed, that figure should be entered to reflect overcrowding.

If more than one type of student station is currently installed, thus requiring multiple entries, the optimum for each type should be entered, as though each type were the only type of student station currently installed in the room. Different types of student stations may reflect distinct optimum estimates.

Position
Responsible

Instructions For Completion

The data must be right justified.. The lowest order digit must be entered in column 32. Unrequired high order positions must be completed with a zero (0). For example, if a large auditorium could accommodate a maximum of 3,560 seating stations under peak conditions and continue to operate satisfactorily, the estimate of 3,560 would be entered as follows:

| OPTIMUM | | | | |
|---------|----|----|----|----|
| 28 | 29 | 30 | 31 | 32 |
| 0 | 3 | 5 | 6 | 0 |

Refer to Appendix K for the listing of all facilities for which station entries must be made. Enter zeros (0) in columns 28-32 for rooms for which no station estimate is required.

- m. Installed Student Stations: Tabulate and enter the actual number of installed student stations in the room by type of student station. (Refer to item n.) Enter the total for each type of installed station in columns 33-37. The data must be right justified. (Refer to item k. for the discussion and illustration of the right justified entry.)
- n. Type Installed Station: Determine the type of installed student station and enter the appropriate type of student station code in columns 38 and 39. For rooms having more than one type of installed student station use additional lines to designate each. (Refer to Appendix K for the listing of all facilities for which student station entries must be made and the type of student station codes.) Vertical lines must be shown in all other data fields to indicate that all additional station data pertains to the same room. (Refer to Exhibit III-A for the illustration of these lines.)
- o. Multiple Student Stations: If a room has only one type of installed student station, enter a zero (0) in column 40. If a room has more than one type of installed student station, enter the number installed by type for each type of station on successive lines and place the digit one (1) in column 40 for the first type of installed station, the digit two (2) for the second, etc.

Position
Responsible

Instructions For Completion

- p. Total Pages: When the last room in each building has been completely inventoried, the total number of pages of room inventory documents completed for each building is entered in the space provided in the upper right corner of each sheet. For example, if five sheets of inventory documents were completed for one building, the entry in item a. above would be completed on each sheet to read:

Sheet 1 of 5

Sheet 2 of 5

and so forth

4. Forward the completed Room Inventory Document to the Institution Study Coordinator.

INSTITUTION
STUDY
COORDINATOR

1. Add each returned completed Room Inventory Document to the completed documents file.
2. Return all completed Room Inventory Documents to the Pennsylvania State Commission on Academic Facilities when all facilities on campus have been completely inventoried, including the building inventory (Section II).

INSTITUTIONAL ROOM INVENTORY BY BUILDING

SHEET 4 OF 4

| | | | | |
|----------------------------------|---|---|---------------------------------------|-------------------------------|
| INSTITUTION CODE 33000 | INSTITUTION NAME WHEELING COMMUNITY COLLEGE | FORM PREPARED BY JOHN G. RECORDED | INVENTORY DATE JAN 17, 1968 | BUILDING NUMBER 027 |
|----------------------------------|---|---|---------------------------------------|-------------------------------|

| ROOM | | | | | | | | | | | | | | | | | | | | | | | | | | | STATIONS | | | | | | | | | | | | | REMARKS |
|--------|----------|------|------------|------------------------|----|----|----|----|----|----|----|----|----|----|----|----|---------|-----------|---|---|---|---|---|---|---|---|----------|---|---|--|--|--|-----------------|-----------|--|--|--|--|--|---------|
| NUMBER | FUNCTION | TYPE | CONDI-TION | ASSIGNABLE SQUARE FEET | | | | | | | | | | | | | | | | | | | | | | | NUMBER | | | | | | TYPE INST. CODE | MULT. USE | | | | | | |
| | | | | 28 | 29 | 30 | 31 | 32 | 33 | 34 | 35 | 36 | 37 | 38 | 39 | 40 | OPTIMUM | INSTALLED | | | | | | | | | | | | | | | | | | | | | | |
| 317 | C | 10 | 14 | 0 | 0 | 3 | 0 | 0 | 2 | 5 | 0 | 0 | 0 | 0 | 0 | 0 | 0 | 2 | 5 | 0 | 0 | 0 | 2 | 3 | 5 | 0 | 1 | 0 | | | | | | | | | | | | |
| 318 | | 10 | 1 | 4 | 5 | 0 | 3 | 0 | 0 | 0 | 1 | 0 | 0 | 0 | 0 | 0 | 0 | 0 | 0 | 0 | 0 | 0 | 0 | 0 | 0 | 0 | 0 | 0 | | | | | | | | | | | | |
| 320 | | 10 | 2 | 5 | 5 | 0 | 1 | 0 | 0 | 0 | 7 | 5 | 0 | 0 | 0 | 0 | 7 | 5 | 0 | 0 | 0 | 7 | 0 | 0 | 9 | 0 | 0 | 0 | | | | | | | | | | | | |
| 401 | | 10 | 1 | 2 | 0 | 0 | 5 | 0 | 0 | 0 | 6 | 0 | 0 | 0 | 0 | 0 | 9 | 0 | 0 | 0 | 0 | 8 | 5 | 0 | 0 | 0 | 1 | 0 | | | | | | | | | | | | |
| | | | | | | | | | | | | | | | | | | 0 | 0 | 0 | 2 | 0 | 0 | 0 | 1 | 5 | 0 | 1 | 2 | | | | | | | | | | | |
| | | | | | | | | | | | | | | | | | | 0 | 0 | 0 | 1 | 0 | 0 | 0 | 0 | 5 | 0 | 2 | 3 | | | | | | | | | | | |
| 401 | B | 2 | 0 | 3 | 0 | 5 | 0 | 3 | 0 | 0 | 0 | 1 | 2 | 0 | 0 | 0 | 0 | 0 | 0 | 0 | 0 | 0 | 0 | 0 | 0 | 0 | 0 | 0 | | | | | | | | | | | | |
| 403 | | 10 | 1 | 1 | 0 | 0 | 1 | 0 | 0 | 1 | 2 | 0 | 0 | 0 | 0 | 1 | 4 | 0 | 0 | 0 | 0 | 9 | 0 | 0 | 0 | 0 | 1 | 0 | | | | | | | | | | | | |
| | | | | | | | | | | | | | | | | | | 0 | 0 | 0 | 2 | 5 | 0 | 0 | 0 | 2 | 0 | 1 | 2 | | | | | | | | | | | |
| | | | | | | | | | | | | | | | | | | 0 | 0 | 0 | 1 | 5 | 0 | 0 | 0 | 1 | 0 | 2 | 3 | | | | | | | | | | | |
| 405 | | 10 | 6 | 0 | 1 | 0 | 3 | 0 | 0 | 4 | 5 | 0 | 0 | 0 | 0 | 7 | 7 | 5 | 0 | 0 | 7 | 5 | 0 | 0 | 6 | 0 | 0 | 0 | | | | | | | | | | | | |
| 410 | | 10 | 1 | 2 | 0 | 0 | 3 | 0 | 0 | 0 | 9 | 2 | 5 | 0 | 0 | 1 | 6 | 5 | 0 | 0 | 1 | 0 | 5 | 0 | 0 | 1 | 0 | 1 | | | | | | | | | | | | |
| | | | | | | | | | | | | | | | | | | 0 | 0 | 0 | 4 | 0 | 0 | 0 | 3 | 0 | 0 | 1 | 2 | | | | | | | | | | | |
| | | | | | | | | | | | | | | | | | | 0 | 0 | 0 | 3 | 5 | 0 | 0 | 0 | 2 | 0 | 2 | 3 | | | | | | | | | | | |
| | | | | | | | | | | | | | | | | | | 0 | 0 | 0 | 4 | 0 | 0 | 0 | 1 | 0 | 0 | 4 | 4 | | | | | | | | | | | |
| | | | | | | | | | | | | | | | | | | 0 | 0 | 0 | 0 | 2 | 0 | 0 | 0 | 2 | 0 | 9 | 5 | | | | | | | | | | | |
| 412 | | 10 | 1 | 3 | 0 | 0 | 1 | 0 | 0 | 0 | 1 | 2 | 0 | 0 | 0 | 0 | 2 | 5 | 0 | 0 | 0 | 2 | 0 | 0 | 3 | 0 | 0 | 0 | | | | | | | | | | | | |

BUILDING FUNCTION CATEGORIES,
CODES AND DEFINITIONS

The Functional Building Classification Code is intentionally broad to provide meaningful summarizations for space inventory and projection of future space needs. The functional building categories are briefly defined in the following pages. A building to be classified under one of these categories, must have at least 50 per cent of its assignable space devoted to the category involved.

A building may be found in which space is equally assigned to two or more of these categories. In such an instance, an effort should be made to assign a specific function and code to the building. Appropriate techniques should be developed by each institution for allocating a primary function to each such building. The allocation of space among two or more functions may be made according to budgetary support, type of space, departmental assignment, division of effort, hours of use, or combinations of these criteria. The "multipurpose" category should be used only as a last resort if the designation of a primary function is impossible. For example, a building containing 55 per cent cafeteria assignable space, 25 per cent student union assignable space, 20 per cent office assignable space, would have as its category, Cafeteria-Student Union Building.

BUILDING FUNCTION CATEGORIES AND CODES

10000 INSTRUCTIONAL BUILDINGS

- 10100 Classroom Building
- 10200 Instructional Laboratory Building
- 10300 Library Building
- 10400 Athletic Building
- 10500 Multipurpose Instructional Building (combination of the above)

20000 ORGANIZED ACTIVITIES AND INSTRUCTION - RESEARCH RELATED BUILDINGS

- 20100 Demonstration School Building
- 20200 Home Management Laboratory Building
- 20300 Experiment Station Building
- 20500 Museum Building

30000 RESEARCH BUILDINGS

- 30100 Physical and Natural Sciences Building
- 30200 Social Science Research Building
- 30300 Agricultural Research Building
- 30400 Engineering Research Building
- 30500 Multipurpose Research Building
- 30600 Medical Research Building

40000 GENERAL OFFICE BUILDINGS

- 40100 Faculty Office Building
- 40200 Administrative Office Building
- 40300 Research Office Building
- 40400 Multipurpose Office Building

50000 SERVICE AND RELATED BUILDINGS

- 50100 Maintenance Building
- 50200 Garage Building
- 50300 Warehouse Building
- 50400 Utility and Power Building
- 50500 Heating Plant and/or Cooling Plant
- 50600 Laundry Building

60000 ASSEMBLY BUILDINGS

- 60100 Auditorium or Theatre Building
- 60200 Chapel Building
- 60300 Field House
- 60400 Armory Building
- 60500 Stadium

70000 RESIDENTIAL FACILITIES BUILDINGS

- 70100 Men's Residence Building
- 70200 Women's Residence Building
- 70300 Co-educational Residence Building
- 70400 Married Students Housing
- 70500 Faculty and/or Staff Housing
- 70600 Fraternity House
- 70700 Sorority House

80000 STUDENT SERVICES AND OTHER AUXILIARY BUILDINGS

- 80100 Cafeteria Building
- 80200 Student Union Building
- 80300 Cafeteria - Student Union Building
- 80400 Student or University Press Building
- 80500 Book Store
- 80600 Post Office Building
- 80700 University Hotel
- 80800 Central Food Stores Building

90000 HOSPITAL BUILDINGS

- 90100 Student Health Building
- 90200 Human Hospital Building
- 90300 Veterinary Hospital Building
- 90400 Dental Clinic Building

BUILDING FUNCTION DEFINITIONS

10000 INSTRUCTIONAL BUILDING

- 10100 Classroom Building: contains rooms generally referred to as Lecture Rooms, Lecture-Demonstration Rooms, Seminar Rooms, or General Classrooms. A classroom may be equipped with tablet arm chairs (movable or stationary), tables and chairs (as in a seminar room), or similar types of seating. This building may be furnished with special equipment appropriate to a specific area of study if this equipment does not render the building unsuitable for use by classes in other areas of study.
- 10200 Instructional Laboratory Building: contains rooms designed and/or furnished with specialized equipment to serve the needs of a particular area of study for group instruction in regularly scheduled classes. The design and/or equipment in such a room normally precludes its use for other areas of study. Included in this building are rooms generally referred to as Teaching Laboratories, Instructional Shops, Typing Laboratories, Drafting Rooms, Band Rooms, Choral Rooms, (Group) Music Practice Rooms, Language Laboratories, (Group) Studios, and similar specially designed and/or equipped rooms if they are used primarily for group instruction in regularly scheduled classes.
- 10300 Library Building: contains rooms generally referred to as Library Stacks, Open Stack Reading Rooms, and Library Processing Rooms, and may include Law Libraries, Graduate Libraries, and Business and Commerce Libraries.
- 10400 Athletic Building: contains rooms generally referred to as Gymnasiums, Basketball Courts, Handball Courts, Squash Courts, Wrestling Rooms, Weight-Lifting Rooms, Natatorium, Ice-Rinks, and Locker Rooms.
- 10500 Multipurpose Instructional Building: contains an equal (or nearly equal) number of rooms of a combination of two or more of the above categories.

20000 ORGANIZED ACTIVITIES AND INSTRUCTION - RESEARCH
RELATED BUILDINGS

20100 Demonstration School Building: contains rooms which normally serve irregularly scheduled classes but are used for instruction as well as research as Special Class Laboratories, and Individual Study Stations.

20200 Home Management Laboratory Building: contains rooms which are used by regularly scheduled classes for practice in Home Management.

20300 Experiment Station Building: contains rooms such as testing rooms, consultation rooms, which are Clinic Facilities (Non-Medical), and Audio-Visual, Radio, TV Facilities, and Computer Centers.

20400 Museum Building: contains rooms generally referred to as Museum Rooms, Art Galleries, Museum Study Rooms, and Study Collections.

30000 RESEARCH BUILDINGS

30100 Physical and Natural Sciences Building: contains rooms which are generally referred to as Non-Class Laboratories (or Research Laboratories) in the field of Physical and Natural Science. This building may be a greenhouse which serves as a Physical and Natural Science Research Laboratory.

30200 Social Science Research Building: contains rooms which are devoted to Social Science Research.

30300 Agricultural Research Building: contains rooms devoted to Agricultural Research as greenhouses, Animal Care Shelters, and Farm Machinery Shops.

30400 Engineering Research Building: contains rooms devoted and equipped for Engineering Research in all or any field of engineering.

30500 Multipurpose Research Building: contains an equal (or nearly equal) number of rooms of a combination of two or more of the above categories.

30600 Medical Research Building: Contains rooms devoted to, and equipped for, medical research in all or any field of medicine.

40000 GENERAL OFFICE BUILDINGS

40100 Faculty Office Building: contains offices used by faculty members, graduate assistants, and teaching assistants as offices.

40200 Administrative Office Building: contains offices used by administrative staff or clerical staff.

40300 Research Office Building: contains offices used by research personnel (either students, graduates, or faculty).

40400 Multipurpose Office Building: contains an equal (or nearly equal) number of rooms of a combination of two or more of the above categories.

50000 SERVICE AND RELATED BUILDINGS

50100 Maintenance Building: contains rooms generally referred to as carpenter shops, plumbing shops, electrical shops, painting shops, and maintenance materials supply shop.

50200 Garage Building: devoted to storage of vehicles as automobiles, boats, buses, or airplanes.

50300 Warehouse Building: contains rooms (or structures) for storage of materials or supplies for a period of time.

50400 Utility and Power Building: contains electrical and utility substations.

50500 Heating Plant and/or Cooling Plant: contains facilities for heating or cooling of other buildings such as boiler rooms, incinerators, or air conditioners.

50600 Laundry Building: contains facilities for washing, drying, and ironing linens, uniforms and other Institutional material.

60000 ASSEMBLY BUILDINGS

60100 Auditorium or Theatre Building: contains rooms generally referred to as theatres, auditoriums, concert halls, areas, or (livestock) judging pavilions.

60200 Chapel Building: designed and equipped for devotional activities.

60300 Field House: designed and equipped with a large spectator seating area and is used for athletic activities as track, high jump, pole vault, throwing of weights, etc. A field house is usually much larger than a gymnasium.

60400 Armory Building: usually used for ROTC training and meetings.

60500 Stadium: An enclosure of a field with permanent seating used for athletic events.

70000 RESIDENTIAL FACILITIES BUILDINGS

70100 Men's Residence Building: a dormitory for male students.

70200 Women's Residence Building: a dormitory for female students.

70300 Co-educational Residence Building: a combination of a men's dormitory and a women's dormitory.

70400 Married Students Housing: may be either a one-family housing unit or a multi-family unit (as an apartment building) for married students.

70500 Faculty and/or Staff Housing: may include either one-housing units or multiple-housing units (as apartment buildings) for faculty and staff members.

70600 Fraternity House: owned or rented one-housing unit or multiple-housing unit for housing fraternity members (male students).

70700 Sorority House: owned or rented one-housing unit or multiple-housing unit for housing sorority members (female students).

80000 STUDENT SERVICES AND OTHER AUXILIARY BUILDINGS

- 80100 Cafeteria Building: contains a dining area, kitchen area, and food facilities services.
- 80200 Student Union Building: contains recreation area and lounge area for students.
- 80300 Cafeteria - Student Union Building: a combination of cafeteria facilities and a student union (recreation area).
- 80400 Student or University Press Building: contains the facilities for student or university publications (as student newspapers, institution newsletters, bulletins, catalogs, etc.).
- 80500 Book Store: devoted to the sale of books, materials, and merchandise to students, faculty or staff members.
- 80600 Post Office Building: serves the institution in receiving and sending of student, staff, and faculty mail.
- 80700 University Hotel: contains facilities found in a commercial hotel and normally is used by visitors to the institution and students in a hotel administration program.
- 80800 Central Food Stores Building: a central building devoted to the processing and storage of foods used in residence facilities and food facilities.

90000 HOSPITAL BUILDINGS

- 90100 Student Health Building: is generally referred to as an infirmary.
- 90200 Human Hospital Building: contains rooms generally referred to as examination rooms, operating rooms, X-ray rooms, physical therapy rooms, delivery rooms, labor rooms, recovery rooms, and similar facilities which are (or may be) used in the examination and/or treatment of several patients within the course of the day. It may contain such clinics as medical, surgical, obstetric-gynecology, pediatric, otolaryngology, and ophthalmology. Physical and occupational therapy clinics associated with a hospital are also included. This building normally contains rooms generally referred to as bedrooms, wards, nurseries, and similar rooms.
- 90300 Veterinary Hospital Building: contains rooms generally referred to as examination rooms, surgery rooms, X-ray rooms, and similar facilities which are (or may be) used in the examination and/or treatment of several patients within the course of a day. This building normally contains rooms generally referred to as animal rooms, stalls, wards, and similar rooms.
- 90400 Dental Clinic Building: contains rooms used for dental examination and/or treatment.

BUILDING CONSTRUCTION TYPE CODES

| <u>Code</u> | <u>Construction Type</u> |
|-------------|--|
| A | Wood Frame |
| B | Wood Frame With Brick |
| C | Load Bearing Masonry Walls |
| D | Steel Frame |
| E | Reinforced Concrete Frame |
| F | Reinforced Concrete Walls |
| G | Building With Light Weight Metal Walls |
| H | Glass Building (Greenhouse) |
| J | Masonry |
| K | Masonry Walls Wood Joist |
| L | Trailer |

DEFINITIONS OF TYPES OF BUILDING CONSTRUCTION

| <u>Code</u> | <u>Definition</u> |
|-------------|---|
| A | <u>Wood Frame</u> - the entire structural frame of the building is made of wood. |
| B | <u>Wood Frame With Brick</u> - the structural supports are wood. The veneer of the structure is brick. |
| C | <u>Load Bearing Masonry Walls</u> - the masonry walls (usually of cinder or concrete blocks) form the structural support of the load of the building as well as the veneer of the building. |
| D | <u>Steel Frame</u> - the steel frame is the structural support of the building load. There may be a variety of veneer finishes. |
| E | <u>Reinforced Concrete Frame</u> - the structural supports of the building load are reinforced concrete columns or piers, with any variety of veneer finishes. |
| F | <u>Reinforced Concrete Walls</u> - the structural support of the building load is provided by reinforced concrete walls which also may be the veneer of such buildings. |
| G | <u>Building With Light Weight Metal Walls</u> - usually a one-floor building (as maintenance garages) with a light weight I-Beam frame and aluminum walls. |
| H | <u>Glass Buildings</u> - Greenhouses. |
| J | <u>Masonry</u> - the building load is not entirely supported by the masonry structure, but is partially supported by either steel I-Beams, wood beams, or reinforced concrete columns. |
| K | <u>Masonry Walls Wood Joists</u> - the building load is entirely supported by the masonry structure. The floor and ceiling joists are wood. |
| L | <u>Trailer</u> - usually a conventional house or industrial trailer being used as a temporary facility by the institution. |

BUILDING CONDITION CODESCodeCondition DescriptionsFUTURE BUILDINGS

- A Planned And Funded
B Under Construction

EXISTING BUILDINGS

- E Excellent - Continue Use With Scheduled Maintenance (Light)
G Good - Continue Use With Scheduled Maintenance (Average)
S Satisfactory - Continue Use With Scheduled Maintenance (Heavy)
U Unsatisfactory - Continue Use With Minor Alterations
V Obsolete For Current Use - Unusable - Needs Major Rehabilitation
W Totally Obsolete - Should Be Razed
9 Temporary - Recently Acquired To Satisfy Immediate Need, Will See Limited Use Until Better Facilities Available

DETERMINATION OF GROSS BUILDING AREA

DEFINITION

"Gross Area" is defined as the sum of the floor areas included within the outside faces of exterior walls for all stories, or areas, which have floor surfaces.

BASIS FOR MEASUREMENT

Gross area should be computed by measuring from the outside face of exterior walls, disregarding cornices, pilasters, buttresses, etc., which extend beyond the wall face.

DESCRIPTION

In addition to ground-to-top story internal floored spaces obviously covered in the above definition, gross area should include basements (except unexcavated portions), attics, garages, enclosed porches, penthouses and mechanical equipment floors, lobbies, mezzanines, all balconies - inside or outside - utilized for operational functions, and corridors, provided they are within the outside face lines of the building. Roofed loading or shipping platforms should be included whether within or outside the exterior face lines of the building.

LIMITATIONS

Open courts and light wells, or portions of upper floors eliminated by rooms or lobbies which rise above single-floor ceiling height, should not be included in the gross area, nor should enclosed roofed-over areas or floored surfaces with less than 6 ft. 6 in. clear head-room be included unless they can properly be designated and used as either net assignable, mechanical, circulation, or custodial area as outlined below:

Net Assignable Area: the sum of all areas on all floors for building assigned to, or available for assignment to, an occupant, including every type of space functionally usable by an occupant (excepting custodial area, circulation area and mechanical area).

Custodial Area: the sum of all areas on all floors of a building used for building protection, care, maintenance and operation.

Circulation Area: that portion of the gross area - whether or not enclosed by partitions - which is required for physical access to some subdivision of space.

Mechanical Area: that portion of the gross area designed to house mechanical equipment, utility services, and non-private toilet facilities.

ROOM FUNCTION CODES AND DEFINITIONS

The use of a limited number of Functional or Program categories for classification of operating expenditures is a well-established practice among colleges and universities. This dimension of the space classification system is designed to facilitate the allocation of rooms according to the program or functions which they serve.

Institutions may elect to use a variety of techniques in the application of the function classification to physical facilities. To the extent possible, individual rooms should be identified by function. It is recognized, however, that some institutions may find it difficult, if not impossible, to specify a single function for certain rooms because of their multiple use or the variety of programs served by the personnel housed therein.

Appropriate techniques should be developed by each Institution for the allocation of such areas to the appropriate Institutional functions. The allocation of space among two or more functions may be made according to budgetary support, type of space, departmental assignment, division of effort, hours of use or combinations of these techniques. Such allocation may be made with regard to individual rooms, rooms of a specific type, or rooms assigned to a specific department.

NOTE: If a room supports instruction, research, public service, library and/or general administration and Institutional services, the appropriate code for that function should be assigned and not the code for Auxiliary Services. See the definition of Auxiliary Services on page G-4.

FUNCTION CATEGORIES AND CODES

- 10 Instruction
- 20 Research
- 30 Public Service
- 40 Library
- 50 General Administration and Institutional Services
- 60 Auxiliary Services
- 70 Non-Institutional Agencies
- 80 Unassigned Area

- 81 Inactive Area
- 82 Alteration or Conversion Area
- 83 Unfinished Area

DEFINITIONS

10 INSTRUCTION

Any activity the primary objective of which is the transmission or dissemination of knowledge to college students on a group or individual basis, including that portion of graduate instruction involving organized classes for which credit is awarded.

Examples of the types of rooms often wholly allocated to this function are classrooms, class laboratories, and related service facilities. Areas used for "organized activities relating to educational departments" such as laboratory schools and demonstration facilities should also be included here, except to the extent allocable to research and/or public service.

20 RESEARCH

Any activity the primary objective of which is the discovery or application of knowledge, including the research activities engaged in by students as a part of their graduate training.

Examples of the types of rooms often wholly allocated to this function are non-class laboratories, offices assigned to research personnel, and related service facilities.

30 PUBLIC SERVICE

Any activity the primary objective of which is to make available to the general public the benefits of the instructional and/or research activities of an institution of higher education. This definition is intended to include activities of a cultural nature as well as activities frequently described as "extension" or "adult and continuing education."

Examples of the types of room wholly allocable to this function are classrooms and offices used exclusively for extension or continuing education programs.

40 LIBRARY

The orderly collection, storage, and retrieval of knowledge. This activity may be housed in a central location or decentralized and housed in two or more separate facilities. In either case, those activities which are under the supervision and control of a "Director of Libraries" and are available for use by more than one department within an institution of higher education should be included in this category.

50 GENERAL ADMINISTRATION AND INSTITUTIONAL SERVICES

Any activity the primary objective of which is the orderly planning and operation of the instruction, research, and/or public service functions of an institution of higher education in terms of academic affairs, fiscal affairs, personnel, student affairs, public relations, development, etc. For the purposes of this classification system, this category is intended to include the functions represented by the budget categories of General Administration, General Services, and Physical Plant.

60 AUXILIARY SERVICES

Activities which are characteristically represented by the types of physical facilities classified by "Room Type" and "GENERAL-USE FACILITIES" and "RESIDENTIAL FACILITIES" except to the extent such activities support instruction, research, public service, library, and/or general administration and institutional services.

70 NON-INSTITUTIONAL AGENCIES

Public or private agencies not under the supervision or control of the institutional administration.

80 UNASSIGNED

All areas which are unassigned at the time of the inventory either because of the nature of the space or because of its present condition.

81 Inactive Space

Included in this category are areas which are available for assignment to one of the above functions but are unassigned at the time of the inventory.

82 Alteration Or Conversion

Included in this category are areas which are temporarily out of use because they are under alteration or conversion.

83 Unfinished

Included in this category are areas in new buildings or additions to existing buildings which are unfinished at the time of the inventory.

TYPE OF ROOM CODES AND DEFINITIONS

The classification of types of rooms reflects certain principles which will sufficiently serve the needs of the State's Bureau of Higher Education Facilities to deal with the complex problems of a space inventory and utilization. However, if the institution finds it useful and desires a finer precision than this classification of room types, they may further categorize the following classifications for their own use, understanding that the following code and classification must be used for State reporting. The principles of the system are enumerated below.

- The type of room definitions hopefully encompass all types of space found in buildings on the campus of an institution of higher education. Although some types of space may be of less interest than others, the omission of any space may lead to the inadvertent omission of appropriate data.
- Since classroom and teaching laboratory utilization studies form an important part of the study, the classification scheme distinguishes between those rooms for which such a utilization study is appropriate, and those rooms or facilities for which such analyses are not appropriate, even though they are used for instructional purposes.
- Terms associated with function or subject-matter areas are avoided in the classification of room types. This classification is based on the Primary Use of the room. This principle must be kept in mind, for an institution to accurately classify room types in the appropriate categories.
- The following classification should be compatible with the institution's existing inventory methods of classifying rooms. If an institution does not have such a classification of room types, it may benefit the institution to incorporate this entire code and classification for its inventory methods. The categories of space are hopefully specific enough for purposes of collecting statistical information at the institutional level. The broadness of a category must be determined by its usefulness in the calculation of space utilization and projection of space needs.

- A corollary of the preceding principle, is that any such system should produce meaningful and comparable summary data. Thus, for comparative purposes, it is intended that the definition of lecture rooms, for example, is sufficiently specific to give reasonable assurance that all institutions will report the same types of space within this category.

- Should an institution possess a space which they feel cannot be classified under any of the following categories, the institution should contact Mr. Keith Gentzler (phone number (717) 787-2057), Comprehensive Program Planning Director, Bureau of Higher Education Facilities, Department of Public Instruction, in room 221 of the Education Building, Harrisburg, Pennsylvania.

TYPE OF ROOM CLASSIFICATIONS AND CODES

100 CLASSROOM FACILITIES

- 110 Lecture Rooms
- 115 Lecture Rooms Service

- 120 Lecture - Demonstration Rooms
- 125 Lecture - Demonstration Rooms Service

- 130 Seminar Rooms
- 135 Seminar Rooms Service

- 140 General Classrooms
- 145 General Classrooms Service

200 LABORATORY FACILITIES

- 205 Teaching Laboratories
- 210 Teaching Laboratories Service

- 215 Instructional Shops
- 220 Instructional Shops Service

- 225 Typing Laboratories
- 230 Typing Laboratories Service

- 235 Drafting Rooms
- 240 Drafting Rooms Service

- 245 Band, Choral & Music Practice Rooms
- 250 Band, Choral & Music Practice Rooms Service

- 255 Language Laboratories
- 260 Language Laboratories Service

- 265 Individual Study Laboratories
- 270 Individual Study Laboratories Service

- 275 Special Class Laboratories
- 280 Special Class Laboratories Service

- 285 Non-Class Laboratories
- 290 Non-Class Laboratories Service

300 OFFICE FACILITIES

- 305 Faculty Offices
- 310 Faculty Offices Service

- 315 Administrative Offices
- 320 Administrative Offices Service

- 325 Clerical Office
- 330 Clerical Offices Service

- 335 Graduate Student Offices
- 340 Graduate Student Offices Services

- 345 Teaching Assistant Offices
- 350 Teaching Assistant Offices Service

- 355 Student Activities Offices
- 360 Student Activities Offices Services

- 365 Conference Rooms
- 370 Conference Rooms Service

400 STUDY FACILITIES

- 405 Study Rooms

- 410 Individual Study Rooms

- 415 Library Stacks

- 420 Open Stack Reading Rooms

- 425 Library Processing Rooms

- 430 Museum Study Rooms

- 435 Study Collections

- 440 Study Facilities Service

500 SPECIAL-USE FACILITIES

- 501 Armory Facilities
- 502 Armory Facilities Service

- 505 Gymnasium Facilities
- 506 Gymnasium Facilities Service

- 509 Basketball Courts
- 510 Basketball Courts Service

- 513 Handball Courts
- 514 Handball Courts Service

- 517 Squash Courts
- 518 Squash Courts Service

- 521 Wrestling Rooms
- 522 Wrestling Rooms Service

- 525 Weight-lifting Rooms
- 526 Weight-lifting Rooms Service

- 529 Natatorium
- 530 Natatorium Service

- 533 Ice Rinks
- 534 Ice Rinks Service

- 537 Fieldhouses
- 538 Fieldhouses Service

- 541 Locker Rooms (Men Students)
- 542 Locker Rooms Service (Men Students)

- 545 Locker Rooms (Women Students)
- 546 Locker Rooms Service (Women Students)

- 549 Locker Rooms (Men Staff and Officials)
- 550 Locker Rooms Service (Men Staff and Officials)

- 553 Locker Rooms (Women Staff and Officials)
- 554 Locker Room Service (Women Staff and Officials)

500 SPECIAL-USE FACILITIES (Cont'd)

557 Men Coach's Offices
558 Men Coach's Offices Service

561 Women Coach's Offices
562 Women Coach's Offices Services

565 First-Aid Rooms
566 First-Aid Rooms Service

569 Outdoor Athletic Stadium
570 Outdoor Athletic Stadium Service

573 Indoor Spectator Seating Facilities

577 Audio-Visual, Radio, TV Facilities
578 Audio-Visual, Radio, TV Facilities Service

581 Clinic Facilities (Non-Medical)
582 Clinic Facilities Service (Non-Medical)

585 Demonstration Facilities
586 Demonstration Facilities Service

589 Field Service Facilities

600 GENERAL-USE FACILITIES

601 Assembly Facilities
602 Assembly Facilities Service

605 Chapels
606 Chapels Service

609 Museums
610 Museums Service

613 Art Galleries
614 Art Galleries Service

617 Food Facilities
618 Food Facilities Service

600 GENERAL-USE FACILITIES (Cont'd)

621 Health Facilities

622 Health Facilities Service

625 Lounge Facilities

626 Lounge Facilities Service

629 Merchandising Facilities

630 Merchandising Facilities Service

633 Recreation Facilities

634 Recreation Facilities Service

637 Public Toilet Facilities (Men)

638 Public Toilet Facilities Service (Men)

641 Public Toilet Facilities (Women)

642 Public Toilet Facilities Service (Women)

700 SUPPORTING FACILITIES

705 Data Processing - Computer Programming Facilities

710 Data Processing - Computer Programming Facilities Service

715 Shop Facilities

720 Shop Facilities Service

725 Storage Facilities

730 Storage Facilities Service

735 Vehicle Storage

740 Vehicle Storage Service

745 Heating Plant Facilities

750 Heating Plant Facilities Service

755 Central Food Stores

760 Central Laundry

765 Mechanical Facilities

770 Mechanical Facilities Service

800 MEDICAL CARE FACILITIES

- 805 Human Hospital - Clinic Facilities
- 810 Human Hospital - Clinic Facilities Service

- 815 Human Hospital - Patient Care Facilities
- 820 Human Hospital - Patient Care Facilities Service

- 825 Dental Clinic Facilities
- 830 Dental Clinic Facilities Service

- 835 Veterinary Hospital - Clinic Facilities
- 840 Veterinary Hospital - Clinic Facilities Service

- 845 Veterinary Hospital - Animal Care Facilities
- 850 Veterinary Hospital - Animal Care Facilities Service

900 RESIDENCE FACILITIES

- 901 Single Men's Residence
- 902 Men's Residential Kitchen and Dining Area
- 903 Men's Residential Recreation Areas
- 904 Single Men's Residence Service

- 910 Single Women's Residence
- 911 Women's Residential Kitchen and Dining Area
- 912 Women's Residential Recreation Areas
- 913 Single Women's Residence Service
- 914 Coeducational Kitchen and Dining Area
- 915 Coeducational Recreation Area
- 916 Coeducational Residence Service

- 920 Married Students, One-Family Housing
- 921 Residential Kitchen and Dining Area (One-Family)
- 922 Residential Recreation Area (One-Family)
- 923 Married Students, One-Family Housing Service

- 930 Married Students, Multiple-Family Housing
- 931 Residential Kitchen and Dining Area (Multiple-Family)
- 932 Residential Recreation Area (Multiple-Family)
- 933 Married Students, Multiple-Family Housing Service

- 940 Faculty Housing Facilities
- 941 Residential Kitchen and Dining Area (Faculty)
- 942 Residential Recreation Area (Faculty)
- 943 Faculty Housing Facilities Service

990 UNASSIGNED AREA

991 Inactive Area

992 Alteration or Conversion Area

993 Unfinished Area

TYPE OF ROOM DEFINITIONS

100 CLASSROOM FACILITIES

110 Lecture Rooms

Definition: A room used by regularly scheduled classes and used only for lecture purposes.

Description: A Lecture Room includes those large rooms equipped with semielliptical rows of seats oriented toward some focal point. The rows generally are tiered from the front to the back of the room.

Limitations: This category does NOT include general classrooms, seminar type rooms, or any room in which the facilities include demonstration equipment (as Lecture-Demonstration rooms or Laboratories). This category does NOT include Auditoriums. Auditoriums are distinguished from lecture rooms on the basis of primary use; a large room with seating oriented toward some focal point which is used for dramatic or musical productions, or for general meetings is an Assembly Facility (i. e., an auditorium normally used for other than scheduled classes).

115 Lecture Rooms Service

Definition: A room which directly serves a Lecture Room as an extension of the activities of the Lecture Room.

Description: Included in this category are projection rooms, cloak rooms, preparation rooms, closets, and storage which serve a lecture room.

Limitations: This category does NOT include projection rooms, cloak rooms, preparation rooms, closets, and storage, if such rooms serve Lecture-Demonstration rooms, Seminar rooms, general classrooms, laboratories, conference rooms, assembly facilities, etc. A projection room in an auditorium is classified as Auditorium Service.

120 Lecture-Demonstration Rooms

Definition: A room used by classes which do not require special-purpose equipment for student use.

Description: A Lecture-Demonstration Room is a Lecture Room which has special-purpose equipment at focal point of the room for the Instructor's demonstration purposes only.

Limitations: This category does NOT include a room strictly used as a Lecture Room, Seminar rooms, or General Classrooms. This category does NOT include an Auditorium or Conference Room.

125 Lecture-Demonstration Rooms Service

Definition: A room which directly serves a Lecture-Demonstration Room as an extension of the activities of the Lecture-Demonstration Room.

Description: Included in this category are projection rooms, cloak rooms, preparation rooms, closets, and storage which serve a Lecture-Demonstration Room.

Limitations: This category includes projection rooms, cloak rooms, etc., only if such rooms serve Lecture-Demonstration Rooms.

130 Seminar Rooms

Definition: A smaller room used by classes which do not require special-purpose equipment for student use.

Description: Included in this category are rooms usually equipped with a large table and chairs, or the equivalent, and ordinarily but not necessarily exclusively used for smaller organized classes.

Limitations: This category does NOT include conference rooms. Conference rooms are distinguished from seminar rooms on the basis of primary use; a room with tables and chairs which is used primarily for meetings (as opposed to classes) is a Conference Room.

135 Seminar Rooms Service

Definition: A room which directly serves a Seminar Room as an extension of the activities of the Seminar Room.

Description: Included in this category are projection rooms, cloak rooms, preparation rooms, closets, and storage which serve a seminar room.

Limitations: This category does NOT include projection rooms, closets, etc., if such rooms do NOT serve Seminar Rooms.

140 General Classrooms

Definitions: A room used by classes which do not require special-purpose equipment for student use.

Description: A General Classroom is usually equipped with tablet-arm chairs (fixed to the floor, joined together in groups, or flexible in arrangement) or desk-chair combinations. A General Classroom may be furnished with special equipment appropriate to a specific area of study if this equipment does not render the room unsuitable for use by classes in other areas of study.

Limitations: This category does NOT include Lecture rooms, Lecture-Demonstration rooms, Seminar rooms, conference rooms, or class laboratories.

145 General Classrooms Service

Definition: A room which directly serves a General Classroom as an extension of the activities of the General Classroom.

Description: Included in this category are projection rooms, cloak rooms, preparation rooms, closets, and storage which serve a General Classroom.

Limitations: This category does NOT include projection rooms, cloak rooms, etc., if such rooms do NOT serve General Classrooms.

200 LABORATORY FACILITIES

205 Teaching Laboratories

Definition: A room used by regularly scheduled classes which require special-purpose equipment for student participation, experimentation, observation, or practice in a field of study.

Description: A Teaching Laboratory is designed and/or furnished with specialized equipment to serve the needs of a particular area of study for group instruction in regularly scheduled classes. The design and/or equipment in such a room normally precludes its use for other areas of study.

Limitations: This category does NOT include laboratory rooms which serve as individual (or independent) study rooms. It does NOT include laboratories used for group instruction which are informally or irregularly scheduled. This category does NOT include rooms generally referred to as research laboratories. It does NOT include Instructional Shops, Typing Laboratories, Drafting Rooms, Band, Choral, and Music Practice Rooms, Language Laboratories, etc. It does NOT include Gymnasiums, pools, drill halls, laboratory Schools, teaching clinics, demonstration houses, and similar facilities which are included under SPECIAL-USE FACILITIES.

210 Teaching Laboratory Service

Definitions: A room which directly serves a Teaching Laboratory as an extension of the activities of the Teaching Laboratory.

Description: Included in this category are balance rooms, cold rooms, stock rooms, dark rooms, equipment issue rooms, animal rooms, greenhouses, and similar facilities which serve a Teaching Laboratory.

Limitations: This category does NOT include balance rooms, cold rooms, dark rooms, animal rooms, greenhouses, etc., which serve instructional shops, typing laboratories, drafting rooms, music rooms, language laboratories, or a Non-Class Laboratory.

215 Instructional Shops

Definitions: A room used by regularly scheduled classes which require special-purpose equipment for student participation, observation, or practice in a field of study.

Description: An Instructional Shop differs from a Laboratory in that a laboratory is particularly devoted to experimental study, testing, analyzing, and observing in any science, where an instructional shop is devoted to observation and/or practice in a field of study, excluding experimentation.

Limitations: This category does NOT include rooms or shops which serve as individual (or independent) study rooms. It does NOT include Instruction Shops used for group instruction which are informally or irregularly scheduled. It does NOT include Research Laboratories, Teaching Laboratories, Drafting Rooms, Band, Choral and Music Practice Rooms, Language Laboratories, etc.

220 Instructional Shops Service

Definition: A room which directly serves an Instructional Shop as an extension of the activities of the Instructional Shop.

Description: Included in this category are balance rooms, cold rooms, stock rooms, equipment issue rooms, and similar facilities which serve an Instructional Shop.

Limitations: This category does NOT include balance rooms, cold rooms, stock rooms, equipment issue rooms, etc., which serve Teaching Laboratories, typing laboratories, drafting rooms, music rooms, language laboratories, or a Non-Class Laboratory.

225 Typing Laboratories

Definition: A room used by regularly scheduled classes which require typing equipment for student participation and practice.

Description: A typing Laboratory is designed and furnished with typewriters and other special-typing equipment to serve the needs of group typing instruction in regularly scheduled classes. The design and/or equipment in such a room may preclude its use for other areas of study.

225 Typing Laboratories (Cont'd)

Limitations: This category does NOT include laboratory rooms which serve as individual (or independent) study rooms. It does NOT include laboratories used for group instruction which are informally or irregularly scheduled. This category does NOT include any SPECIAL-USE FACILITIES such as testing rooms, or demonstration rooms.

230 Typing Laboratories Service

Definition: A room which directly serves a Typing Laboratory as an extension of the activities of the typing Laboratory.

Description: Included in this category are stock rooms, equipment issue rooms, and similar facilities which serve a Typing Laboratory.

Limitations: This category does NOT include stock rooms, and equipment issue rooms, etc., which serve a Non-Class Laboratory.

235 Drafting Rooms

Definition: A room used by regularly scheduled classes which require drafting equipment for student participation and practice.

Description: A Drafting Room is designed and furnished with drafting equipment to serve the needs in the area of drafting for group instruction in regularly scheduled classes. The design and equipment in such a room normally preclude its use for other areas of study.

Limitations: This category does NOT include drafting rooms which serve as individual (or independent) study rooms. It does NOT include drafting rooms used for group instruction which are irregularly scheduled. This category does NOT include rooms generally referred to as research laboratories or SPECIAL-USE FACILITIES.

240 Drafting Room Service

Definition: A room which directly serves a Drafting Room as an extension of the activities of the drafting room.

Description: Included in this category are stock rooms, equipment issue rooms, and similar facilities which serve a Drafting Room.

Limitations: This category does NOT include stock rooms, equipment issue rooms, etc., which serve Non-Class Laboratories.

245 Band, Choral, And Music Practice Rooms

Definition: A room used by regularly scheduled music classes which is designed for student participation and practice.

Description: A Band, Choral or Music Practice Room is designed and/or furnished with special equipment to serve the needs of music students for group instruction in regularly scheduled classes.

Limitations: This category does NOT include music rooms which serve as individual (or independent) study rooms. It does NOT include music rooms used for group instruction which are informally or irregularly scheduled. This category does NOT include SPECIAL-USE FACILITIES as sound studios, testing rooms, film libraries, or tape libraries.

250 Band, Choral And Music Practice Rooms Service

Definition: A room which directly serves a Band Room, Choral Room, or Music Practice Room as an extension of the activities of the Band, Choral or Music Practice Room.

Description: Included in this category are stock rooms, equipment issue rooms, storage rooms, and similar facilities which serve a Band, Choral or Music Practice Room.

Limitations: This category does NOT include stock rooms, equipment issue rooms, storage rooms, etc., which serve a Non-Class Room.

255 Language Laboratories

Definition: A room used by regularly scheduled classes which require booths with special-audio equipment for student participation and practice in the language arts.

Description: A Language Laboratory is designed and furnished with semi-soundproof booths or stations with audio equipment for student instruction and/or practice.

Limitations: This category does NOT include laboratory rooms which serve as individual (or independent) study rooms. It does NOT include laboratories used for group instruction which are informally or irregularly scheduled.

260 Language Laboratories Service

Definition: A room which directly serves a Language Laboratory as an extension of the activities of the Language Laboratory.

Description: Included in this category are stock rooms, supporting control rooms, equipment repair and service shops, storage rooms, and similar facilities which serve a Language Laboratory.

Limitations: This category does NOT include stock rooms, supporting control rooms, etc., which serve a Non-Class Laboratory.

265 Individual Study Laboratory

Definition: A room especially equipped and/or designed for individual student experimentation, observation, or practice in a particular field of study.

Description: Included in this category are music practice rooms, individual study laboratories, and similar rooms which serve a particular subject-matter area. Stations may be grouped (as in an individual study laboratory) or individualized (as in a music practice room).

Limitations: This category does NOT include individual study facilities which are intended for general study purposes. Study facilities not related to a specific area of study are classified as Study Rooms.

270 Individual Study Laboratory Service

Definition: A room which directly serves an Individual Study Laboratory as an extension of the activities in such a facility.

Description: Included in this category are rooms which serve Individual Study Laboratories.

Limitations: This category does NOT include rooms which serve Class Laboratories, Special Class Laboratories, Non-Class Laboratories, or Study Facilities Service.

275 Special Class Laboratory

Definition: A room used by informally (or irregularly) scheduled classes which require special-purpose equipment for student participation, experimentation, observation, or practice in a field of study.

Description: A Special Class Laboratory is designed and/or furnished with specialized equipment to serve the needs of a particular area of study for group instruction in informally (or irregularly) scheduled classes. The design and/or equipment in such a room normally precludes its use for other areas of study. Special Class Laboratories typically (but not necessarily or exclusively) include such rooms as language laboratories, (group) music practice rooms, (group) studios, etc., if such laboratories are irregularly scheduled.

Limitations: This category does NOT include Class Laboratories, individual study rooms, or research laboratories. It does NOT include gymnasiums, pools, drill halls, laboratory schools, teaching clinics, demonstration houses, and similar facilities which are included under SPECIAL-USE FACILITIES.

280 Special Class Laboratory Service

Definition: A room which directly serves a Special Class Laboratory as an extension of the activities in such a facility.

Description: Included in this category are rooms which serve Special Class Laboratories.

Limitations: This category does NOT include rooms which serve Class Laboratories, Individual Study Laboratories, or Non-Class Laboratories.

285 Non-Class Laboratory

Definition: A room used for laboratory applications, research, and/or training in research methodology which requires special-purpose equipment for staff and/or student experimentation or observation.

Description: Included in this category are rooms generally referred to as research laboratories and research laboratory-office combinations. The room is usually equipped with laboratory benches, specialized scientific equipment, and/or such utilities as gas, water, steam, air, etc. Those rooms which have office type equipment and fixed laboratory type equipment (primarily in the biological and physical sciences) within the same room should be classified as a non-class laboratory.

285 Non-Class Laboratory (Cont'd)

Limitations: This category does NOT include rooms generally referred to as teaching laboratories; see Class Laboratory, Special Class Laboratory, and Individual Study Laboratory, above.

290 Non-Class Laboratory Service

Definition: A room which directly serves a Non-Class Laboratory as an extension of the activities of the Non-Class Laboratory.

Description: Included in this category are balance rooms, cold rooms, stock rooms, dark rooms, animal rooms, greenhouses, etc., which serve a Non-Class Laboratory.

Limitations: This category does NOT include balance rooms, cold rooms, stock rooms, dark rooms, animal rooms, greenhouses, etc., which serve a Class Laboratory, a Special Class Laboratory, or an Individual Study Laboratory.

300 OFFICE FACILITIES

305 Faculty Offices

Definition: A room used by faculty members working at a desk (or table).

Description: A Faculty Office is a room typically equipped with one or more desks, chairs, tables, bookcases, and/or filing cabinets for faculty use.

Limitations: This category does NOT include administrative offices, clerical offices, graduate assistant offices, teaching assistant offices, or student activities offices. This category does NOT include rooms which are equipped both as office and "research laboratory." A room equipped with laboratory benches, specialized scientific equipment, and/or such utilities as gas, water, steam, air, etc., is classified as a Non-Class Laboratory. Note that this distinction rests on equipment rather than function. It is recommended that those rooms which have office type equipment and fixed laboratory type equipment (primarily in the biological and physical sciences) within the same room be classified in the Non-Class Laboratory category. Large rooms, such as glass shops, printing shops, reading rooms, research laboratories, etc., which have a desk space for a technician or staff member are classified according to the primary purpose of the room rather than office.

310 Faculty Office Service

Definition: A room which directly serves a Faculty Office (or group of Faculty Offices) as an extension of the activities in a Faculty Office (or group of Faculty Offices).

Description: Included in this category are file rooms, mimeograph rooms, vaults, waiting rooms, interview rooms, closets, private toilets, records rooms, and office supply rooms. Centralized mimeograph and printing shops which are campus-wide in scope should be classified as Shop Facilities.

Limitations: This category does NOT include centralized mimeograph and printing shops.

315 Administrative Offices

Definition: A room used by staff members working at a desk (or table).

Description: An Administrative Office is a room typically equipped with one or more desks, chairs, tables, bookcases, and/or filing cabinets for Administrative Staff use.

Limitations: This category does NOT include faculty offices, clerical offices, graduate assistant offices, teaching assistant offices, or student activities offices. (See Faculty Office Limitations, paragraph 2).

320 Administrative Office Service

Definition: A room which directly serves an Administrative Office (or group of Administrative Offices) as an extension of the activities in an Administrative Office (or group of Administrative Offices).

Description: Included in this category are file rooms, mimeograph rooms, vaults, waiting rooms, interview rooms, closets, private toilets, records rooms, and office supply rooms.

Limitations: This category does NOT include centralized mimeograph and printing shops. Centralized mimeograph and printing shops which are campus-wide in scope should be classified as Shop Facilities.

.325 Clerical Offices

Definition: A room used by clerks working at a desk (or table).

Description: A Clerical Office is typically equipped with one or more desks, chairs, tables, bookcases, and/or filing cabinets for Clerical use.

Limitations: This category does NOT include faculty offices, administrative offices, graduate assistant offices, student activities offices, or centralized mimeograph and printing shops. Centralized mimeograph and printing shops which are campus-wide in scope should be classified as Shop Facilities. (See Faculty Office Limitations.)

330 Clerical Offices Service

Definition: A room which directly serves a Clerical Office (or group of Clerical Offices) as an extension of the activities in a Clerical Office (or group of Clerical Offices).

Description: Included in this category are file rooms, mimeograph rooms, vaults, waiting rooms, interview rooms, closets, private toilets, records rooms, and office supply rooms.

Limitations: This category does NOT include centralized mimeograph and printing shops. Centralized mimeograph and printing shops which are campus-wide in scope should be classified as Shop Facilities.

335 Graduate Student Assistant Offices

Definition: A room used by a Graduate Student Assistant working at a desk (or table).

Description: A Graduate Student Assistant Office is typically equipped with one or more desks, chairs, tables, bookcases, and/or filing cabinets for a Graduate Student Assistant's use.

Limitations: This category does NOT include faculty offices, Administrative offices, clerical offices, teaching assistant offices, and student activities offices. (See Faculty Offices Limitations.)

340 Graduate Student Assistant Offices Service

Definition: A room which directly serves a Graduate Student Assistant Office (or group of Graduate Student Assistant Offices) as an extension of the activities in a Graduate Student Assistant Office (or offices).

Description: Included in this category are file rooms, mimeograph rooms, vaults, waiting rooms, interview rooms, closets, private toilets, records rooms, and office supply rooms.

Limitations: This category does NOT include centralized mimeograph and printing shops. Centralized mimeograph and printing shops which are campus-wide in scope should be classified as Shop Facilities.

345 Teaching Assistant Offices

Definition: A room used by a Teaching Assistant working at a desk (or table); typically the student grades papers or compares clerical work for a faculty member.

Description: A Teaching Assistant Office is a room typically equipped with one or more desks, chairs, tables, bookcases, and/or filing cabinets for a Teaching Assistant's use.

Limitations: This category does NOT include faculty offices, administrative offices, clerical offices, graduate assistant offices, or student activities offices. (See Faculty Office Limitations.)

350 Teaching Assistant Offices Service

Definition: A room which directly serves a Teaching Assistant Office (or Offices) as an extension of the activities in a Teaching Assistant Office (or Offices).

Description: Included in this category are file rooms, mimeograph rooms, vaults, waiting rooms, interview rooms, closets, private toilets, records rooms, and office supply rooms.

Limitations: This category does NOT include centralized mimeograph and printing shops. Centralized mimeograph and printing shops which are campus-wide in scope should be classified as Shop Facilities.

355 Student Activities Office

Definition: A room used by students, who are engaged in campus activities, working at a desk (or table).

Description: A Student Activities Office is a room typically equipped with one or more desks, chairs, tables, bookcases, and/or filing cabinets for student use.

Limitations: This category does NOT include faculty offices, administrative offices, clerical offices, graduate assistant offices, or teaching assistant offices. (See Faculty Office Limitations.)

360 Student Activities Offices Service

Definition: A room which directly serves a Student Activities Office (or Offices) as an extension of the activities in a Student Activities Office (or Offices).

Description: Included in this category are filing rooms, mimeograph rooms, vaults, waiting rooms, interview rooms, closets, private toilets, records rooms, and office supply rooms.

Limitations: This category does NOT include centralized mimeograph and printing shops. Centralized mimeograph and printing shops which are campus-wide in scope should be classified as Shop Facilities.

365 Conference Room

Definition: A room used by non-class groups for meetings.

Description: A Conference Room may be equipped with tables and chairs, lounge-type furniture, straight-back chairs, and/or tablet arm chairs. It typically (but not necessarily) is assigned to a department for its use. It is distinguished from such Classroom Facilities as seminar rooms, lecture rooms, and general classrooms because it is used primarily for activities other than (scheduled) classes.

Limitations: This category does NOT include classrooms, seminar rooms, lecture rooms, auditoriums, interview rooms, or lounges.

370 Conference Room Service

Definition: A room which directly serves a Conference Room as an extension of the activities of the Conference Room.

Description: Included in this category are such rooms as kitchenettes, chair storage rooms, projection rooms, sound equipment rooms, etc.

Limitations: This category does NOT include kitchens, dining rooms, and similar facilities in a centralized conference-type building. (Dining rooms open to the student body at large and/or the public are categorized as Food Service Facilities.)

400 STUDY FACILITIES

405 Study Rooms

Definition: A room used to study books or audio-visual materials on an individual basis.

Description: Study Rooms are classified as to their basic primary use. Included in this category are rooms generally referred to as Study Halls which are intended for general study purposes, and is NOT occupied by bookshelves or stack.

Limitations: This category does NOT include Library Reading Rooms in which the basic primary users are grouped study stations where Stack is available for student use. It does NOT include Library Stack. This category does NOT include Individual Study Stations, Study Booths, or Carrels which may include typewriters, remote terminals of a computer, electronic display equipment, etc. It does NOT include Museum Study Rooms, Open Stack Reading Rooms, Library Processing Rooms, Study Collections, or Study Facilities Service. This category does NOT include Classrooms, Class Laboratories, Special Class Laboratories, Non-Class Laboratories, Offices, combined sleeping-study rooms in residence halls, or other housing units, waiting rooms, or lounges.

410 Individual Study Room

Definition: A room that is within or adjoining the stacks which is intended for general study of books or audio-visual materials on an individual basis.

Description: An Individual Study Room is commonly equipped with Study Booths or Carrels. Individual Study Rooms may be equipped with typewriters, remote terminals of a computer, tape recorders, record players, electronic display equipment, etc., for the individual's use.

Limitations: This category does NOT include group Study Rooms or Study Halls, Open-Stack Reading Rooms, Library Processing Rooms, etc. This category does NOT include Individual Study Laboratories. Individual Study Laboratories are generally limited in use to a particular area of study, such as an individual chemistry laboratory.

415 Library Stacks

Definition: A room (or portion of a room) used to provide shelving for books or audio-visual materials used by staff and/or students on an individual basis.

Description: Included in this category are rooms generally referred to as Stacks, which are ranges of shelving units (i. e., two or more paralleled rows of double-faced shelving units).

Limitations: This category does NOT include single-faced shelving units standing against (or built into) the walls and/or single rows of free-standing single- or double-faced units standing against partitions which are in Individual Study Stations, Open-Stack Reading Rooms, Library Processing Rooms, or in any Classrooms, Laboratories, or Offices. Audio-visual film and tape libraries which generally serve groups (rather than individuals) are classified as Audio-Visual, Radio, TV Facilities. Separate tape storage rooms for language laboratories should be classified as Language Laboratory Service. Rooms containing such materials (as records and tapes) intended for listening enjoyment (as in a student Union) should be classified as Recreation Facilities Service. Stacks serving Non-Class Laboratories should be classified as Non-Class Laboratory Service. This category does NOT include a Study Collection (i. e., a room which holds a departmental collection and is only for this Department's use, or a Commemorated Collection of books, memorandums, or anthropological, botanical, or geological specimens).

420 Open Stack Reading Rooms

Definition: A room which is a combination of Study Room and Stack, generally without physical boundaries between the stack areas and the study areas.

Description: Included in this category are rooms generally referred to as Library Reading Rooms.

Limitations: This category does NOT include Study Halls or Study Rooms, Stack Individual Study Stations, Library Processing Rooms, Museum Study Rooms, Study Collections, or Study Facilities Service.

425 Library Processing Rooms

Definition: A room which serves a Study Room, Individual Study Station, Library Stacks, Open-Stack Reading Rooms, Museum Study Rooms, or Study Collections as a supporting service to such rooms.

Description: Included in this category are rooms generally referred to as card catalog, circulation desk, bookbinding, microfilm processing, and audio-visual record-playback equipment for distribution to individual study stations.

Limitations: This category does NOT include such library spaces as: offices for staff (which are classified under Offices); acquisitions work areas (which are classified as Offices); campus-wide or centralized audio-visual preparation areas, bookbinding, and microfilm processing areas (which are classified as Shops); instructional facilities for Library Science staff (which are classified under CLASSROOM FACILITIES, LABORATORY FACILITIES, OFFICE FACILITIES, or other appropriate designations.

430 Museum Study Rooms

Definition: A room in a Museum which is available for special-purpose study on an individual basis. This room usually includes Stack.

Description: A Museum Study Room is very similar to a Library Reading Room. However, a Museum Study Room must be in a Museum and is used for study in a specific field of study. This room also includes any single-faced shelving units standing against (or built into) the walls in the Museum Study Room.

Limitations: This category does NOT include a room (or portion of a room) which has ranges of two or more paralleled rows of double-faced shelving units (this is classified as Library Stack). This category does NOT include a Study Room that is not within a Museum Building.

435 Study Collections

Definition: A room that is used for a departmental collection or display.

Description: A Study Collection includes a departmental collection which is a collection of books, memoranda, and audio-visual materials for a specific department's use. It also includes a room which is a Commemorated Collection of books, memoranda, or anthropological, botanical, or geological specimens; however, this room is not a part of a Museum or art gallery.

Limitations: This category does NOT include a portion of a Museum or Art Gallery. (These are classified under General-Use Facilities.)

440 Study Facilities Service

Definition: A room which directly serves a Study Room, Individual Study Room, Library Stacks, Open-Stack Reading Room, Library Processing Room, Museum Study Rooms, or Study Collections as a direct extension of the activities in such rooms.

Description: Other categories have provided a "service" category for each type of room. Because such facilities are minimal in library-type spaces this one category of Study Facilities Service is provided for all types of STUDY FACILITIES. Included are such areas as closets, locker space, coatrooms, etc.

Limitations: This category does NOT include card catalogs, circulation desks, and other areas designated under Library Processing Rooms.

500 SPECIAL-USE FACILITIES

501 Armory Facilities

Definition: A room (or area) used by ROTC units.

Description: This category includes indoor drill areas, rifle ranges, and special-purpose military science rooms.

Limitations: Classroom Facilities, Laboratory Facilities, and Office Facilities in an Armory are designated as such.

502 Armory Facilities Service

Definition: A room which directly serves an Armory Facility as an extension of the activities of such a facility.

Description: This category includes supply rooms, weapons rooms, etc.

Limitations: Classroom Service Laboratory Service, and Office Service rooms are so classified even though they are located in an Armory.

505 Gymnasium Facilities

Definition: A room used by students, staff, or the public for athletic activities.

Description: Included in this category are rooms generally used for Physical Education Classes, and may possibly be used for basketball, wrestling, etc., if there are not any separate basketball courts, wrestling rooms, etc.

Limitations: No distinction is made on the basis of instruction versus intramural or intercollegiate use of gymnasiums, basketball courts, natatoriums, etc. This category does NOT include Classrooms, Laboratories, or Offices even though they may be located in a gymnasium (or Athletic) building. This category does NOT include the fixed spectator seating area (fixed spectator seating areas are classified as Indoor Spectator Seating Facilities) associated with athletic facilities. It does NOT include separate basketball courts, handball courts, squash courts, wrestling rooms, ice rinks, fieldhouses, outdoor athletic stadiums, weight-lifting rooms, natatoriums, locker rooms, first-aid rooms, or instructor's offices.

506 Gymnasium Facilities Service

Definition: A room which directly serves a gymnasium as an extension of the activities of a gymnasium.

Description: Included in this category are rooms generally referred to as press booths, radio and television booths, storage rooms, broom closets, and lobby areas (as cloak rooms, concession area, entrance lobby, and ticket booths)

Limitations: This category does NOT include public toilet rooms, locker rooms, locker room service, first-aid rooms, instructor's offices.

509 Basketball Courts

Definition: A room used by students, staff, or the public only as a basketball court.

Description: Included in this category are indoor basketball courts.

Limitations: This category does NOT include gymnasiums, handball courts, squash courts, wrestling rooms, etc. It does NOT include any outdoor facilities as outside basketball courts, tennis courts, fixed Spectator Seating Areas, such facilities are classified as Indoor Spectator Seating Facilities. This category does NOT include Class-rooms, Laboratories, or Offices even though they are located in the same building. This category does NOT include locker rooms, first-aid rooms, instructor's offices.

510 Basketball Courts Service

Definition: A room which directly serves an Indoor Basketball Court as an extension of the activities of the basketball court.

Description: Included in this category are rooms referred to as press booths, radio and television booths, storage rooms, broom closets, and lobby area, etc.

Limitations: This category does NOT include public toilet rooms, locker rooms, locker room service, first-aid rooms, instructor's offices.

513 Handball Courts

Definition: A room used by students, staff, or the public only for the purpose of handball activities.

Description: Only handball courts are included in this category. A handball court normally is a four-walled enclosed court, 20' - 0" wide by 40' - 0" long by 20' - 0" high.

Limitations: This category does NOT include gymnasium, basketball courts, squash courts, wrestling rooms, etc. It does NOT include Classrooms, Laboratories, or Offices, even though they are located in the same building.

514 Handball Courts Service

Definition: A room which directly serves a Handball Court as an extension of the activities of a handball court.

Description: Included in this category are rooms referred to as storage rooms, broom closets, etc.

Limitations: This category does NOT include public toilet rooms, locker rooms, locker room service, first-aid rooms, and instructor's offices.

517 Squash Courts

Definition: A room used by students, staff, or the public for the purpose of Squash activities.

Description: Only squash courts are included in this category. A squash court normally is a four-walled enclosed court, 18' - 6" wide by 32' - 0" long by 16' - 0" high.

Limitations: This category does NOT include gymnasium, basketball courts, handball courts, wrestling rooms, etc. It does NOT include Classrooms, Laboratories, or Offices even though they are located in the same building.

518 Squash Courts Service

Definition: A room which directly serves a Squash Court as an extension of the activities of a squash court.

Description: Included in this category are storage rooms, broom closets, etc.

Limitations: This category does NOT include public toilet rooms, locker rooms, locker room service, first-aid rooms, instructor's office.

521 Wrestling Rooms

Definition: A room used by students, staff, or the public for wrestling purposes.

Description: Only rooms used for wrestling are included in this category. If a gymnasium is used for wrestling purposes, it is classified under Gymnasium Facilities.

Limitations: A Wrestling Room does NOT include gymnasiums, basketball courts, handball courts, squash courts, etc., such facilities have their own classifications. This category does NOT include fixed Spectator Seating Area, such facilities are classified as Indoor Spectator Seating Facilities. This category does NOT include Classrooms, Laboratories, or Offices even though they are located in the same building.

522 Wrestling Rooms Service

Definition: A room which directly serves a Wrestling Room as an extension of the activities of a wrestling room.

Description: Included in this category are storage rooms, broom closets, etc.

Limitations: This category does NOT include public toilet rooms, locker rooms, locker room service, first-aid rooms, instructor's offices.

525 Weight-Lifting Rooms

Definition: A room used by students, staff, or the public for the purpose of weight-lifting.

Description: Only rooms used for weight-lifting are included in this category. Facilities in this room normally include barbells, bench-press, and other similar weight-lifting equipment.

Limitations: This category does NOT include a portion of the gymnasium, if the Athletic Building does not have a weight-lifting room, and the gymnasium (or a portion) is used for such purposes. Such facilities are classified as Gymnasium Facilities. This category does NOT include Spectator Seating Areas. This category does NOT include Classrooms, Laboratories, or Office even though they are located in the same building.

526 Weight-Lifting Rooms Service

Definition: A room which directly serves a Weight-lifting Room as an extension of the activities of a weight-lifting room.

Description: Included in this category are storage rooms, broom closets, etc.

Limitations: This category does NOT include public toilet rooms, locker rooms, locker rooms service, first-aid rooms, instructor's offices.

529 Natatorium

Definition: A room used by students, staff, or the public for swimming purposes.

Description: Included in this category is the entire room in which a swimming pool is located.

Limitations: This area does NOT include the fixed Spectator seating area, such facilities are classified as Indoor Spectator Seating Facilities. It does NOT include Classrooms, or Office which may be located in the same building or area.

530 Natorium Service

Definition: A room which directly serves Natatorium Facilities as an extension of the activities of the Natatorium.

Description: Included in this category are storage rooms, broom closets, etc.

Limitations: This category does NOT include public toilet rooms, locker rooms, locker room service, first-aid rooms, instructor's offices.

533 Ice Rinks

Definition: A room (or area) used by students, staff, or the public for ice-skating.

Description: An Ice Rink is essentially an enclosed sheet of artificial ice used for ice-skating.

Limitations: This category does NOT include outside ice rinks. It does NOT include fixed Spectator Seating Areas, such facilities are classified as Indoor Spectator Seating Facilities. This category does NOT include locker rooms, locker room service, offices, etc.

534 Ice Rinks Service

Definition: A room which directly serves an Ice-Rink as an extension of the activities of an ice rink.

Description: Included in this category are press booths, radio and television booths, storage rooms, broom closets, lobby areas, etc.

Limitations: This category does NOT include public toilet rooms, locker rooms, locker room service, first-aid rooms, instructor's offices.

537 Fieldhouses

Definition: A room (or area) used by students, staff, or the public for athletic activities which may also take place on an outdoor field.

Description: A Fieldhouse is NOT a gymnasium. The two are distinguishable by their basic primary use. A gymnasium is usually for indoor athletic activities (as basketball, wrestling, acrobatics, etc.). A fieldhouse is primarily for athletic activities which may take place outdoors (such as track, high jump, pole vault, throwing of weights, etc.). A fieldhouse is usually much larger than a gymnasium.

Limitations: This category does NOT include gymnasium, basketball courts, wrestling rooms, natatorium, or ice rinks. This category does NOT include locker rooms and their service. It does NOT include Classrooms or Offices which may be in the building.

538 Fieldhouses Service

Definition: A room which directly serves a Fieldhouse as an extension of the activities of a fieldhouse.

Description: Included in this category are rooms as press booths, radio and television booths, storage rooms, broom closets, and lobby areas, etc.

Limitations: This category does NOT include public toilet rooms, locker rooms, locker room service, first-aid rooms, instructor's offices.

541 Locker Rooms (Men Students)

Definition: A room (or area) used by male students for changing and storing athletic clothing and/or equipment.

Description: Included in this category are rooms generally referred to as General Locker Rooms, Varsity Team Locker Rooms and Visiting Team Locker Rooms.

Limitations: This category (or area) does NOT include locker rooms service (as equipment supply and issue rooms, shower rooms, coaches rooms, toilet rooms, and laundry rooms).

542 Locker Rooms Service (Men Students)

Definition: A room (or area) which directly serves a men students' locker room as an extension of the activities of such a facility.

Description: Included in this category are rooms generally referred to as equipment supply issue rooms, shower rooms, toilet rooms and laundry rooms.

Limitations: This category does NOT include public toilet rooms.

545 Locker Rooms (Women Students)

Definition: A room (or area) used by female students for changing and storing athletic clothing and/or equipment.

546 Locker Room Service (Women Students)

Definition: A room (or area) which directly serves a women students' locker room as an extension of the activities of such a facility, such as equipment supply issue rooms, shower rooms, laundry rooms, and toilet rooms (excluding public toilet rooms).

549 Locker Rooms (Men Staff And Officials)

Definition: A room (or area) used by male staff and officials as a room for changing and storing athletic clothing and/or equipment.

550 Locker Rooms Service (Men Staff And Officials)

Definition: A room (or area) which directly serves a Locker Room for male staff and officials as an extension of the activities of such a facility, such as equipment supply issue rooms, shower rooms, laundry rooms, and toilet rooms (excluding public toilet rooms).

553 Locker Rooms (Women Staff And Officials)

Definition: A room (or area) used by female staff and officials as a room for changing and storing athletic clothing and/or equipment.

554 Locker Rooms Service (Women Staff And Officials)

Definition: A room (or area) which directly serves a Locker Room for female staff and officials as an extension of the activities of such a facility, such as equipment supply issue rooms, shower rooms, and toilet rooms (excluding public toilet rooms).

557 Men Coach's Offices

Definition: A room (or area) which is used by the coaches, who are not instructors of Physical Education Classes (which would be classified as Faculty Offices), but who are the coaches of the football team, basketball team, soccer team, etc.

558 Men Coach's Offices Service

Definition: A room (or area) which directly serves a Men Coach's Office as an extension of the activities of such a facility, such as a private toilet room, file room, etc.

561 Women Coach's Offices

Definition: A room (or area) which is used by the coaches, who are not instructors of Physical Education Classes (which would be classified as Faculty Offices), but who are the coaches of the volleyball team, basketball team, field hockey team, etc.

562 Women Coach's Offices Service

Definition: A room (or area) which directly serves a Women Coach's Office as an extension of the activities of such a facility, such as a private toilet room, file room, etc.

565 First-Aid Rooms

Definition: A room (or area) used to treat students, staff or the public with first-aid if they are injured during an athletic activity.

Description: Only first-aid rooms are included in this category. The room is an examination room for emergency use during physical education classes or athletic activities.

Limitations: This category does NOT include Student Health Facilities which is a centrally located facility, and is classified as such. This category does NOT include non-medical facilities.

566 First-Aid Rooms Service

Definition: A room (or area) which directly serves a First-Aid Room as an extension of the activities in such a facility.

Description: Included in this category are rooms generally referred to as record rooms, waiting rooms, linen closets, storage closets, etc.

Limitations: This category does NOT include service rooms for teaching clinics, teaching hospitals, non-medical facilities, or centrally located Student Health Facilities.

569 Outdoor Athletic Stadium

Definition: An enclosure of a field with permanent seating used for Athletic events.

Description: A field which is enclosed with permanent spectator seating (usually of a concrete foundation) which is tiered and oriented toward the center of the playing field.

Limitations: This category does NOT include a Stadium without permanent Spectator Seating. It does NOT include outdoor basketball courts, tennis courts, archery ranges, or golf courses. This category does NOT include the Permanent Spectator Seating Area. This facility is classified as Outdoor Spectator Seating Facilities.

570 Outdoor Athletic Stadium Services

Definition: A room which directly serves an Outdoor Athletic Stadium as an extension of the activities of such a facility.

Description: Included in this category are storage rooms, etc.

Limitations: This category does NOT include the permanent spectator seating facilities (this is classified as Outdoor Spectator Seating Facilities). It does NOT include locker rooms, locker rooms service, instructor's offices, or first-aid rooms. It does NOT include vehicle storage (this is classified under SUPPORTING FACILITIES).

573 Indoor Spectator Seating Facilities

Definition: The seating area used by students, staff, and the public to observe indoor athletic events.

Description: Included in this category are fixed or permanent seating areas in gymnasiums, basketball courts, natatoria, ice rinks, indoor tracks, indoor "fields", and fieldhouses.

Limitations: This category does NOT include the Permanent Seating Area in an Outdoor Stadium. This category does NOT include temporary or movable-seating areas.

577 Audio-Visual, Radio, TV Facilities

Definition: A room or group of rooms used in the production and distribution of instructional media.

Description: Rooms generally referred to as TV studios, radio studios, sound studios, graphics studios, and similar rooms are included in this category.

Limitations: Studios used primarily as part of an instructional program to train students in communication techniques should be classified as a Laboratory (if scheduled) or a Laboratory Service (if not scheduled).

578 Audio-Visual, Radio, TV Facilities Service

Definition: A room which directly serves an Audio-Visual, Radio, or TV Facility as an extension of the activities in such facilities.

Description: Included in this category are rooms generally referred to as film library, tape library, control room, video tape recorder room, property storage, recording rooms, and engineering maintenance rooms.

Limitations: Control rooms, recording rooms, and similar facilities used primarily to train students in communications techniques should be classified as a Laboratory (if scheduled) or a Laboratory Service (if not scheduled).

581 Clinic Facilities (Non-Medical)

Definition: A room used for the diagnosis and/or treatment of patients in a program other than medicine (human or veterinary), dentistry, and student health care.

Description: Rooms generally referred to as patient examination rooms, testing rooms, consultation rooms are included in this category. Clinics are typically associated with such educational areas as psychology, speech and hearing, remedial reading, and remedial writing.

Limitations: This category does NOT include clinics associated with student health care. It does NOT include clinics for the medical or dental treatment of humans or animals.

582 Clinic Facilities Service (Non-Medical)

Definition: A room which directly serves a Clinic as an extension of the activities in a Clinic.

Description: Waiting rooms, observation rooms, control rooms, records rooms, and similar supporting rooms are included in this category.

Limitations: This category does NOT include rooms which serve Medical Care Facilities.

585 Demonstration Facilities

Definition: A room (or group of rooms) used to practice the principles of certain subject-matter areas, particularly teaching and home management.

Description: This category includes demonstration schools, Laboratory schools, pre-school nurseries, etc., IF the facilities support the training of the college-level students involved as (certified) teachers. This category includes home management houses which serve to train college-level students in home management.

Limitations: Demonstration schools, laboratory schools, pre-school nurseries, and home management houses in which the students serve as the subjects for a research study are classified as Non-Class Laboratory. Rooms which serve nursery, elementary, or secondary school students (in a laboratory school or pre-school nursery) will NOT be classified as Classroom, Class Laboratory, Office, etc., but rather as Demonstration Facilities. However, Classrooms or Laboratories in such facilities used primarily for collegiate level students should be classified as Classrooms or Laboratories. Offices and Conference Rooms used by collegiate level staff should be designated Offices and Conference Rooms.

586 Demonstration Facilities Service

Definition: A room which directly serves a Demonstration Facility as an extension of the activities of the Demonstration Facility.

Description: Included in this category are facilities generally referred to as store rooms, laundry, etc. (in a home demonstration facility) and kitchen, lockers, shower rooms, etc. (in a laboratory school).

Limitations: In general, the primary activity areas such as kitchen, dining room, living room (in a home demonstration house) or classroom, laboratories, gymnasiums (in a laboratory school) should be designated as Demonstration Facilities.

589 Field-Service Facilities

Definition: A barn or similar structure for animal shelter or the handling, storage, and/or protection of farm products, supplies, and tools.

Description: Field-Service Facilities include barns, animal shelters, sheds, silos, feed units, hay storage, and seedhouses. Greenhouses related to farm operations are included in this category. Structures are typically of light frame construction with unfinished interiors, usually related to agricultural field operations, and are frequently located outside the central campus area.

Limitations: Location of a building is NOT sufficient justification for classification as a Field-Service Facility. Finished rooms such as endocrine research laboratories, dairy research laboratories, etc., should be classified as Non-Class Laboratories.

600 GENERAL-USE FACILITIES

601 Assembly Facilities

Definition: A room designed and equipped for dramatic, musical or livestock judging activities.

Description: Rooms generally referred to as theaters, auditoriums, concert halls, arenas, and (livestock) judging pavilions are included in this category. Seating area, stage, orchestra pit, arena, and aisles are included in Assembly Facilities.

Limitations: This category does NOT include Chapels. Assembly rooms are NOT primarily used for instructional purposes. (See Limitations of Lecture Rooms.)

602 Assembly Facilities Service

Definition: A room which directly serves an Assembly Facility as an extension of the activities of such a facility.

Description: This category includes check rooms, coat rooms, dressing rooms, projection booths, property storage, make-up rooms, costume storage, green rooms, control rooms, etc.

Limitations: This category does NOT include service of a Chapel, such facilities are classified as Chapel Service.

605 Chapels

Definition: A room designed and equipped for devotional activities.

Description: Included in this category is the seating area, altar area, and aisles.

Limitations: This category does NOT include any Assembly Facilities rooms.

606 Chapels Service

Definition: A room which directly serves a Chapel as an extension of the activities of such a facility.

Description: This category includes coat rooms, dressing rooms, property storage, etc.

606 Chapels Service (Cont'd)

Limitations: This category does NOT include any Assembly Facilities rooms.

609 Museums

Definition: A room used for exhibits, which are generally of a permanent nature and treat broad cultural, historical, scientific, anthropological or similar subject areas.

Description: This category ONLY includes museums and similar exhibition rooms.

Limitations: This category does NOT include Art Galleries, which are classified separately. Study Collections NOT primarily for general exhibition such as departmental displays of anthropological, botanical, geological specimens should be classified under Study Collections.

610 Museums Service

Definition: A room which directly serves a Museum as an extension of the activities in such a facility.

Description: This category includes work rooms for the preparation of materials and displays, vault or other storage for materials, check rooms, etc.

Limitations: Research areas in a museum are classified as Non-Class Laboratories or Non-Class Laboratory Service.

613 Art Galleries

Definition: A room generally used for exhibits of sculpture and painting.

Description: This category includes only Art Galleries which are of a permanent nature although the specific shows or displays may change.

Limitations: Temporary art exhibits (as in a lobby) are NOT included in this category.

614 Art Galleries Service

Definition: A room which directly serves as Art Gallery as an extension of the activities of such a facility.

Description: This category includes work rooms for the preparation of the displays, vault or other storage for works of art, check rooms, etc.

617 Food Facilities

Definition: A room used for eating food.

Description: This category includes dining halls, cafeterias, snack bars, restaurants, and similar eating areas.

Limitations: This category is limited to facilities which are open to the student body and/or public at large. Dining halls in residence halls (or separate facilities serving a group of residence halls) are classified as Residential.

618 Food Facilities Service

Definition: A room which directly serves a Food Facility as an extension of the activities in such a facility.

Description: This category includes such areas as kitchens, refrigeration rooms, freezers, dishwashing rooms, cafeteria serving areas, and other non-dining areas.

Limitations: This category is limited to service areas in which the Food Facility is open to the student body and/or public at large. Service areas to Food Facilities in residence hall (or a facility serving a group of residence halls) are classified as Residential.

621 Health Facilities (Student)

Definition: A room used for the medical examination or treatment of students.

Description: This category includes examination rooms, bedrooms, surgery rooms, clinics, etc.

621 Health Facilities Service (Student)(Cont'd)

Limitations: This category does NOT include such clinics as speech and hearing clinics, psychology clinics, and similar instructional and/or research facilities. Teaching hospitals for students in Human or Veterinary Medicine are NOT included. Incidental use of a Health Facility by staff members may occur.

622 Health Facilities Service (Student)

Definition: A room which directly serves a Health Facility (Student) as an extension of the activities in such a facility.

Description: Included in this category are such rooms as dispensaries, record rooms, waiting rooms, clinical laboratories, scrub-up rooms, linen closets, etc.

Limitations: This category does NOT include service rooms for teaching clinics or teaching hospitals.

625 Lounge Facilities

Definition: A room used for rest and relaxation.

Description: A lounge is typically equipped with upholstered furniture, draperies, and/or carpeting.

Limitations: A Lounge is distinguished from a Conference Room by its more informal atmosphere and its general public availability.

626 Lounge Facilities Service

Definition: A room which directly serves a Lounge, such as a kitchenette.

629 Merchandising Facilities

Definition: A room (or group of rooms) used to sell products or services.

Description: This category includes such rooms as bookstores, barber shops, post offices, dairy stores, student union "desks", and motel-hotel rooms.

629 Merchandising Facilities (Cont'd)

Limitations: This category does NOT include dining rooms, restaurants, snack bars, and similar Food Facilities. It does NOT include meeting rooms which are classified as Conference Rooms.

630 Merchandising Facilities Service

Definition: A room which directly serves a Merchandising Facility as an extension of the activities in that room.

Description: Included in this category are rooms generally referred to as supply closets, sorting rooms, freezers, telephone rooms, linen rooms, laundry rooms, valet service, and private toilets.

Limitations: This category does NOT include public toilet rooms.

633 Recreation Facilities

Definition: A room used by students (staff and/or the public) for recreational purposes.

Description: This category includes such rooms as bowling alleys, pool and billiards rooms, ping pong rooms, ballrooms, chess rooms, card-playing rooms, (non-instructional) music listening rooms, and hobby rooms.

Limitations: This category does NOT include Gymnasiums, Basketball Courts, Handball Courts, Squash Courts, Wrestling Rooms, Weight-lifting Rooms, Natatorium, Ice Rinks, or Field Houses. It does NOT include outside facilities such as tennis courts, archery ranges, field (football, hockey, etc.) or golf courses.

634 Recreation Facilities Service

Definition: A room which directly serves a Recreation Facility as an extension of the activities of such a facility.

Description: This category includes storage closets, equipment issue rooms, cashier's desk, and similar areas.

Limitations: This category does NOT include kitchens, short-order kitchens, snack bars, or other Food Facilities. It does NOT include any SPECIAL-USE FACILITIES Service area.

637 Public Toilet Facilities (Men)

Definition: A room used by male students, staff, or the public.

Description: Lavatory facilities are installed in this room.

Limitations: This category does NOT include toilet facilities in a men students' locker room or private toilet facilities in an office.

638 Men's Public Toilet Facilities Service (Men)

Definition: A room which directly serves a Men's Public Toilet as an extension of the activities of such a facility.

Description: Storage rooms or linen closets are included in this category.

Limitations: This category does NOT include service of the toilet facilities in a men's locker room.

641 Public Toilet Facilities (Women)

Definition: A room used by female students, staff, or the public.

Description: Laboratory facilities are installed in this room.

Limitations: This category does NOT include toilet facilities in a women students' locker room or private toilet facilities in an office.

642 Public Toilet Facilities Service (Women)

Definition: A room which directly serves a Women's Public Toilet as an extension of the activities of such a facility.

Description: Included in this category are storage rooms or linen closets.

Limitations: This category does NOT include service of the toilet facilities in a women's locker room.

700 SUPPORTING FACILITIES

705 Data Processing-Computer Facilities

Definition: A room (or group of rooms) for institution-wide processing of data by machines or computers.

Description: This category includes keypunch rooms, electronic data processing rooms, electronic computer rooms, and similar data processing areas.

Limitations: This category does NOT include rooms containing desk calculators, posting-billing machines, check-writing machines, and similar Office or Office Service rooms. It is recommended that the area occupied by a keypunch machine, sorter, or other Educational Data Processing equipment in a room otherwise classifiable as an Office NOT be included in this category. A data processing facility used only for instruction should be jointly classified as under Laboratory Facilities. Such a facility used for instruction and/or research and/or administrative data processing should be included in this category.

710 Data Processing-Computer Facilities Service

Definition: A room which directly serves a Data Processing-Computer Facility as an extension of the activities of that facility.

Description: This category includes such rooms as card storage, paper form storage, tape storage, tape storage vaults, control rooms, plugboard storage, wiring rooms, equipment repair rooms, observation rooms, and similar service areas.

Limitations: This category does NOT include offices for data processing personnel which should be classified under Offices.

715 Shop Facilities

Definition: A room used for the manufacture or maintenance of products and equipment.

Description: This category includes such rooms as carpenter shops, plumbing shops, electrical shops, painting shops, and similar physical plant maintenance facilities. It also includes central printing and duplicating shops, central receiving, and central stores.

715 Shop Facilities (Cont'd)

Limitations: This category does NOT include instructional shops; industrial arts and vocational-technical shops used for instruction should be classified under Laboratory Facilities. Highly specialized shops for the production of scientific apparatus and equipment should be classified as Laboratory Service or Non-Class Laboratory Service. Materials preparation areas in Audio-Visual, Radio Stations, and TV Studios should be classified as Audio-Visual, Radio, TV Facilities. Maintenance and repair areas of vehicles, airplanes, boats, etc., should be classified as Vehicle Storage Service. Engineering drafting rooms serving the physical plant operation are classified as Offices. Blueprint storage rooms are classified as an Office Service.

720 Shop Facilities Service

Definition: A room which directly serves a Shop as an extension of the activities of such a room.

Description: Included in this category are tool supply-storage rooms, materials storage rooms, and similar equipment or material supply and/or storage rooms. Locker rooms, shower rooms, lunch rooms, and similar non-public areas should be included.

Limitations: This category does NOT include service areas related to Laboratory Facilities or Non-Class Laboratory Facilities. It does NOT include vehicular repair facilities ("garages") which are classified as Vehicle Storage Service. Blueprint storage rooms should be classified as an Office Service. Public toilets are NOT included.

725 Storage Facilities

Definition: A room used to store materials.

Description And Limitations: Classification of a room as a Storage Facility is limited by definition to a central storage facility (warehouse) and inactive departmental storage. Storage related to other types of space follow the classification of that type of space with a "service" designation. For example, a storage closet for office supplies is classified as an Office Service. The distinction between a "service" classification and "storage" rests on the possibility of physical separation of the materials stored. If the material being stored could be placed in a warehouse, implying only occasional demand for the materials, then Storage Facility is the appropriate classification. Storage which must, by the nature of the materials stored and the demands placed upon them by the program, be close at hand should be classified according to the appropriate "Service" category.

730 Storage Facilities Service

Definition: A room which directly serves a Storage Facility.

735 Vehicle Storage

Definition: A room (or structure) which is used to store vehicles.

Description: This category includes rooms (or structures) generally referred to as garages, boat houses, airport hangars, and other storage areas for vehicles (broadly defined).

Limitations: This category does NOT include portions of barns or similar Field-Service Facilities which are used to house farm implements. Parking structures are NOT included in the facilities inventory.

740 Vehicle Storage Service

Definition: A room (or structure) used to service vehicles.

Description: This category includes any area associated with a Vehicle Storage facility which is used for the maintenance and repair of automotive equipment, boats, airplanes, and similar vehicles.

Limitations: This category does NOT include service areas which serve building maintenance and repair which are classified as Shop Facilities.

745 Heating Plant Facilities

Definition: A room (or area) used for heating of a building (or group of rooms).

Description: Rooms (or areas) generally referred to as heating plants, boiler rooms, incinerators, etc. are included in this category.

Limitations: This category does NOT include rooms used to store fuel. It does NOT include offices in the same area.

750 Heating Plant Facilities Service

Definition: A room which directly serves a heating plant as an extension of the activities of such facilities.

Description: Fuel storage rooms, closet rooms, maintenance and repair rooms, etc. are included in this category.

Limitations: This category does NOT include Industrial Shops or maintenance and repair shops for vehicles.

755 Central Food Stores

Definition: A central facility for the processing and storage of foods used in Residence Facilities and Food Facilities.

Description: Food storage areas, lockers, cold rooms, refrigerators, meat processing areas, and similar facilities located in a Central Food Stores building are included in this category.

Limitations: Offices and conference rooms located in a Central Food Stores building are classified as Offices and Conference Rooms. Food storage areas, freezers, lockers, etc., NOT located in a Central Food Stores building are classified as Food Facilities Service.

760 Central Laundry

Definition: A central facility for washing, drying, and ironing of linens, uniforms, and other institutional material.

Description: Laundry rooms, drying rooms, ironing rooms, etc., located in a Central Laundry are included in this category.

Limitations: Offices and conference rooms located in a Central Laundry are classified as Offices and Conference Rooms. Laundry rooms, drying rooms, ironing rooms, etc., NOT located in a Central Laundry are classified as Residential Facilities or as a Service facility to whatever type of space they serve.

765 Mechanical Facilities

Definition: A room (or area) designed and used to house electrical or mechanical equipment, or a utility service.

Description: Rooms (or areas) generally referred to as fixed mechanical and electrical equipment rooms, transformer rooms, power plant rooms, elevator machine rooms, and water or sewage pumping facilities.

Limitations: This category does NOT include elevator shafts, storage rooms, etc. It does NOT include Industrial Shops, Shop Facilities, Heating Plant Facilities, or Vehicle Storage.

770 Mechanical Facilities Service

Definition: A room which directly serves a Mechanical Facility as an extension of the activities of that facility.

Description: This category includes closet rooms and storage rooms, which service only Mechanical Facilities.

Limitations: This category does NOT include Shop Facilities such as plumbing shops, electrical shops, painting shops, and similar physical plant maintenance facilities. It does NOT include public toilets.

800 MEDICAL CARE FACILITIES

Note: This category does NOT include student health care facilities.
This category does NOT include non-medical clinic facilities.

805 Human Hospital-Clinic Facilities

Definition: A room used for the medical examination and/or treatment of inpatients or outpatients.

Description: This category includes rooms generally referred to as examination rooms, operating rooms, x-ray rooms, physical therapy rooms, delivery rooms, labor rooms, recovery rooms, and similar facilities which are (or may be) used in the examination and/or treatment of several patients within the course of a day. It also includes such clinics as medical, surgical, obstetric-gynecology, pediatric, psychiatric, otorhinolaryngology, and ophthalmology. Physical and occupational therapy clinics associated with a hospital are also included.

Limitations: Human Hospital-Clinic Facilities are distinguished from Human Hospital-Patient Care Facilities primarily on the basis of the length of time which a patient spends in such facilities. Clinic Facilities such as examination rooms, operating rooms, etc., are capable of serving many patients in the course of a day. Patient Care Facilities such as bedrooms, wards, etc., serve as a "home base" for a patient for a relatively long period of time.

This category does NOT include Student Health Care Facilities, Athletic First-Aid Rooms, Non-Medical Clinics, Classrooms, Laboratories, Special Class Laboratories, Offices, Study Facilities, Shops, Merchandising Facilities, and similar rooms which can be otherwise classified.

This category does NOT include Dental Clinics.

810 Human Hospital-Clinic Facilities Service

Definition: A room which serves a Human Hospital-Clinic Facility as a direct extension of the activities in such a room.

Description: This category includes rooms generally referred to as clinical laboratories, pharmacy, radium storage, control rooms, isotope vaults, animal rooms supporting diagnostic functions, and similar rooms which support clinical facilities, but which the patient does not normally enter.

810 Human Hospital-Clinic Facilities Service (Cont'd)

Limitations: Clinic Facilities are distinguished from Clinic Facilities Service on the basis of the presence of patients. Rooms which patients enter for examination and/or treatment are Clinic Facilities. Supporting clinical facilities not normally entered by patients are classified as Clinic Facilities Service.

815 Human Hospital-Patient Care Facilities

Definition: A room which provides a bed for patients in a hospital.

Description: This category includes rooms generally referred to as bedrooms, wards, nurseries, and similar rooms.

Limitations: This category does NOT include Clinic Facilities. (See Limitations in Human Hospital-Clinic Facilities for basis of distinction.) This category does NOT include Patient Care Facilities in a Student Health Center. It does NOT include Non-Medical Clinics, or Athletic First-Aid Rooms.

820 Human Hospital-Patient Care Facilities Service

Definition: A room which serves a Patient Care Facility as a direct extension of the activities in such a room.

Description: This category includes rooms generally referred to as nurses stations, charting rooms, tub rooms, medication rooms, nourishment rooms, formula rooms, and food service facilities for patients.

Limitations: This category does NOT include facilities which support student health care facilities, nor does it include Clinic Service Facilities.

825 Dental Clinic

Definition: A room used for the dental examination and/or treatment of humans.

Description: This category includes rooms generally referred to as dental clinics.

Limitations: This category does NOT include Medical Clinics.

830 Dental Clinic Service

Definition: A room which serves a Dental Clinic as a direct extension of the activities in such a room.

Description: This category includes supporting laboratory services and other facilities which serve a Dental Clinic.

Limitations: Dental Clinic Service rooms are generally NOT entered by patients.

835 Veterinary Hospital-Clinic Facilities

Definition: A room used for the medical examination and/or treatment of animals as inpatients or outpatients.

Description: This category includes rooms generally referred to as examination rooms, surgery rooms, x-ray rooms, and similar facilities which are (or may be) used in the examination and/or treatment of several patients within the course of a day.

Limitations: Veterinary Hospital-Clinic Facilities are distinguished from Veterinary Hospital-Patient Care Facilities primarily on the basis of the length of time which a patient spends in such a facility. Clinic Facilities such as examination rooms, operating rooms, etc., are capable of serving many patients in the course of a day. Patient Care Facilities serve as a "home base" for a patient for a relatively long period of time.

This category does NOT include surgery rooms and similar facilities which serve as preparation areas for Laboratory Facilities or Non-Class Laboratories. Such rooms are classified as Service Facilities to such laboratories.

840 Veterinary Hospital-Clinic Facilities Service

Definition: A room which serves a Clinic Facility as a direct extension of the activities in such a facility.

Description: This category includes rooms generally referred to as clinical laboratories, pharmacy, radium storage, scrub rooms, animal rooms used for diagnostic purposes, etc.

840 Veterinary Hospital-Clinic Facilities Service (Cont'd)

Limitations: Clinic Facilities are distinguished from Clinic Facilities Service on the basis of the presence of patients. Rooms which patients enter for examination and/or treatment are Clinic Facilities. Supporting clinic facilities not normally entered by patients are classified as Clinic Facilities Service.

845 Veterinary Hospital-Animal Care Facilities

Definition: A room which provides a cage or stall for animal patients.

Description: Rooms generally referred to as animal rooms, stalls, wards, and similar rooms are included in this category.

Limitations: This category does NOT include Clinic Facilities. (See Limitations in Veterinary Hospital-Clinic Facilities for basis of distinction.) Animal rooms, stalls, wards, etc., which house animals intended for use in a Laboratory Facility, Non-Class Laboratories, or Human Hospital Clinic Facilities, are classified as Service areas to such rooms.

850 Veterinary Hospital-Animal Care Facilities Service

Definition: A room which serves an Animal Care Facility as a direct extension of the activities in such a room.

Description: This category includes rooms generally referred to as feed storage rooms, feed mixing rooms, cage washing rooms, and similar facilities.

Limitations: This category does NOT include facilities which directly serve animal-care facilities associated with Laboratory Facilities, Non-Class Laboratories, or Human Hospital-Clinic Facilities.

900 RESIDENCE FACILITIES

901 Single Men's Residence

Definition: A residence for unmarried male students, generally referred to as a dormitory.

Description: Included in this category are rooms which are a single male student's private living quarters (which include a student's sleeping area and private study area, usually both areas are one room). The room is usually equipped with beds, dressers, desks, chairs, lamps, and closets.

Limitations: Private closet space is included in this category. It does NOT include bathrooms, dining halls, kitchens, laundry rooms, pressing rooms, and storage rooms, etc. Rooms in a residence hall which serve primarily as classrooms should be classified under CLASSROOM FACILITIES. Offices for staff members should be classified under OFFICE FACILITIES. Study Rooms (for general student use, not areas which are part of the bedrooms) should be classified under STUDY FACILITIES.

902 Men's Residential Kitchen And Dining Area

Definition: An area of a residence hall for single male students designed and equipped to accommodate its residents with kitchen and dining facilities.

Description: Rooms (or areas) generally referred to as serving areas, kitchen areas, dining rooms, dishwashing areas, and kitchenette units are included in this category.

Limitations: This area does NOT include snack bars which is classified as Residential Recreation Areas (under the appropriate sex and housing unit). It does NOT include Central Food Stores (as lockers, cold rooms, refrigerators, and meat processing areas). It does NOT include Central Laundries.

903 Men's Residential Recreation Areas

Definition: An area of a residence hall for single male students designed and equipped to accommodate its residents with Recreation Facilities.

903 Men's Residential Recreation Areas

Description: This category includes rooms generally referred to as TV rooms, bowling lanes, billiard rooms, also rooms equipped for card playing, dancing, ping-pong, record playing, and dispensers for cigarettes, candy, cakes and ice cream.

Limitations: This category does NOT include public facilities as bowling lanes, billiard rooms, etc. It does NOT include such facilities which are centrally located for student, staff, and the public's use.

904 Single Men's Residence Service

Definition: A room which directly serves a Men's Residential bedroom-study area, kitchen and dining area, and/or recreation area, as an extension of the activities of such facilities.

Description: Rooms generally referred to as public lounge and reception facilities, utilities area, entrances, shower rooms, student toilet rooms, storage closets (as luggage), etc. are included in this category.

Limitations: This category does NOT include public toilet rooms. This category does NOT include service area for classrooms, auditoriums, laboratories, etc.

910 Single Women's Residence

Definition: A residence designed for unmarried female students, generally referred to as women's dormitory.

Description: Rooms which are a single female student's private living quarters (which include a student's sleeping area and private study area, usually both areas are one room) are included in this category. This room is usually equipped with beds, dressers, desks, chairs, lamps, and closets.

Limitations: Private closet space is included in this category. It does NOT include bathrooms, dining halls, kitchens, laundry rooms, pressing rooms, and storage rooms, etc. Rooms in a residence hall which serve primarily as classrooms should be classified under CLASSROOM FACILITIES. Offices for staff members should be classified under OFFICE FACILITIES. Study Rooms (for general student use, not areas which are part of the bedrooms, should be classified under STUDY FACILITIES.

911 Women's Residential Kitchen And Dining Area

Definition: An area of a residence hall for single female students designed and equipped to accommodate its residents with kitchen and dining facilities.

Description: Rooms (or areas) generally referred to as serving areas, kitchen areas, dining rooms, dishwashing areas, and kitchenette units are included in this category.

Limitations: This area does NOT include snack bars which is classified as Residential Recreation Areas (under the appropriate sex and housing unit). It does NOT include Central Food Stores (as lockers, cold rooms, refrigerators, and meat processing areas). It does NOT include Central Laundries.

912 Women's Residential Recreation Areas

Definition: An area of a residence hall for single female students designed and equipped to accommodate its residents with Recreation Facilities.

Description: This category includes rooms generally referred to as TV rooms, bowling lanes, etc., and also rooms equipped for card playing, dancing, ping-pong, record playing and dispensers for cigarettes, candy, cold drinks, ice cream, etc.

Limitations: This category does NOT include public facilities as bowling lanes, etc. It does NOT include such facilities which are centrally located for student, staff, and the public's use.

913 Single Women's Residence Service

Definition: A room which directly serves a Women's Residential bedroom-study area, kitchen and dining area, and/or recreation area, as an extension of the activities of such facilities.

Description: Included in this category are rooms generally referred to as public lounge and reception facilities, utilities area, entrances, shower rooms, student toilet rooms, storage closets (as luggage), etc.

Limitations: This category does NOT include public toilet rooms. This category does NOT include service area for classrooms, auditoriums, laboratories, etc.

914 Coeducational Residence Kitchen And Dining Area

Definition: An area designed and equipped to accommodate men and women residents of a coeducational residence facility with kitchen and coeducational dining facilities.

Description: Rooms (or areas) generally referred to as serving area, kitchen areas, dining rooms, dishwashing areas, and kitchenette units are included in this category.

Limitations: This area does NOT include snack bars which are classified as Residential Recreation Areas. It does NOT include Central Food Stores (as lockers, cold rooms, refrigerators, and meat processing areas). It does NOT include dining halls and restaurants which are intended for general use by the student body. Only facilities directly serving a coeducational residence should be coded 914.

915 Coeducational Residence Recreation Area

Definition: An area of a residence hall for coeducational students designed and equipped to accommodate its residents with recreation facilities.

Description: This category includes rooms generally referred to as TV rooms, bowling lanes, billiard rooms, also rooms equipped for card playing, dancing, ping-pong, record playing, with dispensers for cigarettes, candy, cakes and ice cream.

Limitations: This category does not include such public facilities as bowling lanes, billiard rooms, etc., which are centrally located on campus for student, staff and public use.

916 Coeducational Residence Service

Definition: A room or area which directly serves a coeducational residence study area, kitchen and dining area, or recreation area as an extension of the activities of such facilities.

Description: Rooms generally referred to as public lounge and reception facilities, utilities area, entrances, storage closets (as luggage), etc., are included in this category.

Limitations: This category does not include public toilet rooms or service areas for classrooms, auditoriums, laboratories, etc.

920 Married Students, One-Family Housing

Definition: A house provided for one family.

Description: This category includes houses provided for, or rented to married students.

Limitations: This category does NOT include investment properties which may be rented to non-institutional personnel.

921 Residential Kitchen And Dining Area (One-Family Housing)

Definition: A room (or area) which is the centrally located kitchen and dining area for one-family housing units.

Description: Included in this area are rooms referred to as serving areas, kitchen areas, dining rooms, dishwashing area, and kitchenette units.

Limitations: This category does NOT include the kitchen and dining area in the one-family units, this category is for centrally located facilities which will serve these one-family units with cooking and dining areas. This category does NOT include kitchen and dining facilities in a dormitory. It does NOT include snack bars (classified as one-family housing Recreation Area). It does NOT include Central Food Stores (as lockers, cold rooms, refrigerators, and meat processing areas).

922 Residential Recreation Area (One-Family Housing)

Definition: An area which is a centrally located recreation facility for one-family housing units.

Description: Included in this area are rooms referred to as bowling lanes, billiard rooms, dancing areas, snack bars, etc.

Limitations: This category does NOT include public facilities as bowling lanes, billiard rooms, etc. It does NOT include such facilities centrally located for ALL students, staff, and the public's use.

923 Married Students, One-Family Housing Service

Definition: A room which directly serves Married Students One-Family bedroom-study area, kitchen and dining area, and/or recreation area as an extension of the activities of such facilities.

Description: Included in this category are rooms generally referred to as bathrooms, linen closets, cloak closets, laundry rooms, etc. Also included are such services as public lounges. Utilities areas, entrances, toilet rooms, storage closets which may appear in centrally located recreation areas and/or centrally located kitchen and dining areas as a facility strictly for the use of married students living in one-family housing units.

Limitations: This category does NOT include public toilet rooms. This category does NOT include service areas for Classrooms, Laboratories, Auditoriums, etc., which may be included in the same building as a centrally located recreation area and/or kitchen and dining area for married students in a one-family housing unit.

930 Married Students, Multiple Housing

Definition: An apartment type housing unit provided for married students' families.

Description: This category includes apartments provided for or rented to married students.

Limitations: This category does NOT include investment properties which may be rented to non-institutional personnel.

931 Residential Kitchen And Dining Area (Multiple Housing)

Definition: A room (or area) which is the centrally located kitchen and dining area for multiple housing units.

Description: Rooms referred to as serving areas, kitchen areas, dining rooms, dishwashing area, and kitchenette units are included in this area.

931 Residential Kitchen And Dining Area (Multiple Housing)(Cont'd)

Limitations: This category does NOT include the kitchen and dining area in the apartment units of multiple family housing, this category is for centrally located facilities (as a cafeteria) which will serve these student families with cafeteria cooking and dining areas. This category does NOT include kitchen and dining facilities in a dormitory, it does NOT include snack bars (classified as multiple family housing recreation area). It does NOT include Central Food Stores (as lockers, cold rooms, refrigerators, and meat processing areas).

932 Residential Recreation Area (Multiple Housing)

Definition: An area which is a centrally located recreation facility for multiple-family housing units (or apartments).

Description: Included in this area are rooms referred to as bowling lanes, billiard rooms, dancing areas, snack bars, etc.

Limitations: This category does NOT include public facilities as bowling lanes, billiard rooms, etc. It does NOT include such facilities centrally located for ALL students, staff, and the public use.

933 Married Students, Multiple Housing Service

Definition: A room which directly serves a Married Students Multiple-Family residential bedroom-study area, kitchen and dining area and/or recreation area as an extension of the activities of such facilities.

Description: Rooms generally referred to as bathrooms, linen closets, cloak closets, laundry rooms, etc. are included in this category. Also included are such services as public lounges. Utilities areas, entrances, toilet rooms, storage closets which may appear in centrally located recreation areas and/or centrally located kitchen and dining areas as a facility strictly for the use of married students living in multiple-family housing units.

Limitations: This category does NOT include public toilet rooms. This category does NOT include service areas for Classrooms, Laboratories, Auditoriums, etc., which may be included in the same building as a centrally located recreation area and/or kitchen and dining area for married students living in a multiple-family housing unit.

940 Faculty Housing Facilities

Definition: A residence provided for or rented to faculty.

Description: This category includes housing provided for or rented to either married or single faculty members.

Limitations: This category does NOT include investment properties which may be rented to non-institutional personnel.

941 Residential Kitchen And Dining Area (Faculty Housing)

Definition: A room (or area) which is the centrally located kitchen and dining area (or cafeteria) for faculty use.

Description: Rooms referred to as serving areas, kitchen areas, dining rooms, dishwashing areas and kitchenette units which usually are a part of cafeteria facilities are included in this area.

Limitations: This category does NOT include kitchen and dining facilities which are in the immediate faculty housing units. This category does NOT include kitchen and dining facilities (or cafeterias) in a dormitory. It does NOT include snack bars which are classified as Faculty Recreation Area. It does NOT include Central Food Stores (as lockers, cold rooms, refrigerators, and meat processing areas).

942 Residential Recreation Area (Faculty Housing)

Definition: An area which is a centrally located recreation facility for the use of faculty members only.

Description: Included in this area are rooms referred to as bowling lanes, billiard rooms, dancing areas, snack bars, etc.

Limitations: This category does NOT include public facilities as bowling lanes, billiard rooms, etc. It does NOT include such facilities centrally located for ALL students, staff, and public's use.

943 Faculty Housing Facilities Service

Definition: A room which directly serves a Faculty Residential Housing Area, kitchen and dining area, and/or recreation area as an extension of the activities of such facilities.

943 Faculty Housing Facilities Service (Cont'd)

Description: Included in this category are rooms generally referred to as bathrooms, linen closets, cloak closets, laundry rooms, etc. Also included are such services as public lounges. Utilities areas, entrances, toilet rooms, storage closets which may appear in centrally located recreation areas and/or centrally located kitchen and dining areas as a facility strictly for the use of faculty members living in faculty housing.

Limitations: This category does NOT include public toilet rooms. This category does NOT include service areas for Classrooms, Laboratories, Auditoriums, etc. which may be included in the same building as a centrally located recreation area and/or kitchen and dining area for faculty members living in faculty housing.

990 UNASSIGNED

Facilities which are not assigned to, or are not available to, any institutional unit (or non-institutional agency) at the time of the facilities inventory. The overall code 990 is intended only for captions and sub-totals in tabulated reports; itemized data should be coded in terms of the most appropriate of the following categories only:

991 INACTIVE: Rooms or other assignable floor areas which are available for assignment, but which are unassigned at the time of the facilities inventory.

992 ALTERATION OR CONVERSION: Rooms or other assignable floor areas which are temporarily out of use because they are under alteration or conversion (or rehabilitation) at the time of the facilities inventory.

993 UNFINISHED: Rooms or other assignable floor areas in new buildings, or in new additions to existing buildings, which are unfinished at the time of the facilities inventory.

APPENDIX I

ROOM CONDITION CODE

Code

- 01 Excellent - continue use with scheduled maintenance (light)
- 03 Good - continue use with scheduled maintenance (average)
- 05 Satisfactory - continue use with scheduled maintenance (heavy)
- 07 Unsatisfactory - continue use with minor alterations
- 09 Obsolete for current use (unuseable) - needs major rehabilitating
- 11 Temporary: Recently acquired to satisfy immediate needs, will see limited use until better facilities are available.

PROCEDURE FOR CALCULATING
ASSIGNABLE AREA IN SQUARE FEET

Assignable Square Feet is defined as the floor area of a room assigned to, or available for assignment to, an occupant, including every type of space functionally usable by an occupant. All assignable areas should be computed by measuring from the inside finish of permanent outer building walls to the office side of corridors and/or to permanent partitions.

Rooms not normally assigned to an occupant, such as storerooms, should be measured from the inside surfaces of enclosing walls.

Suggested Formulas And Procedures For Room Area Calculation

The following formulas and procedures for obtaining the assignable areas of rooms have been developed to yield accurate and comparable measures of room assignable space. Several of the shapes described may appear in one room. In this case, the area of each shape should be calculated. The total area of the room will equal the sum of all the calculated areas in such a room.

The following shapes have been assigned formulas and/or procedures: square, rectangle, triangle, parallelogram, trapezoid, rhombus, L-shape, circle, segment where (θ) is the angle between two radii (in radians) and two unequal circles, and a sector where a chord subtends an arc.

Net Assignable Area

This means the sum of all areas on all floors of each room. For example, an auditorium is usually slanted to give the audience a better view. The net assignable area in an auditorium is the area using the measurement where the wall and floor coincide; i. e., the measurement is to be taken along the floor. Another example, a lecture room is usually tiered to give the students a better view. The net assignable area in this case is only measured along the floor for each tier (excluding the perpendicular distance between the tiers.)

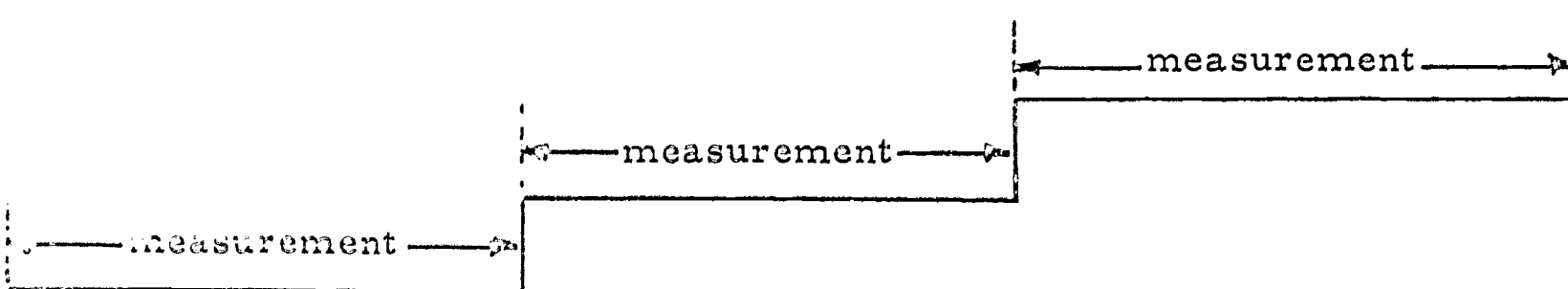

Measurements should not be made for columns and projections necessary to the room.

The suggested formulas and procedures for room area calculation are meant to be representative and not exhaustive of the various types of area calculations which may be required. The most common room designs are included. However, other unusually shaped areas will be encountered. If the area for such rooms cannot be calculated or obtained from the building blueprints, contact Mr. Keith Gentzler, Comprehensive Planning Coordinator, Bureau of Higher Education Facilities, Education Building, Harrisburg, Pennsylvania. Phone: (717) 787-2057.

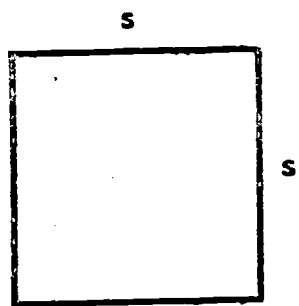

AREA OF A SQUARE:

$Area = S^2$

where: S = side of square

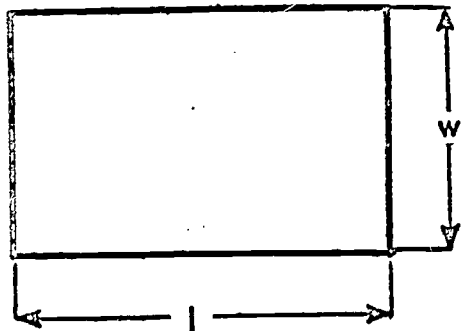

AREA OF A RECTANGLE:

$Area = l \times w$

where: l = length
w = width

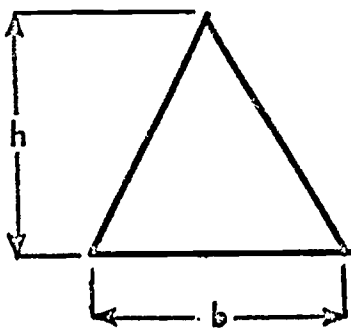
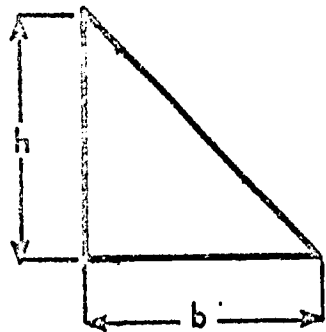

AREA OF A TRIANGLE:

$Area = \frac{1}{2} b h$

where: b = base
h = altitude

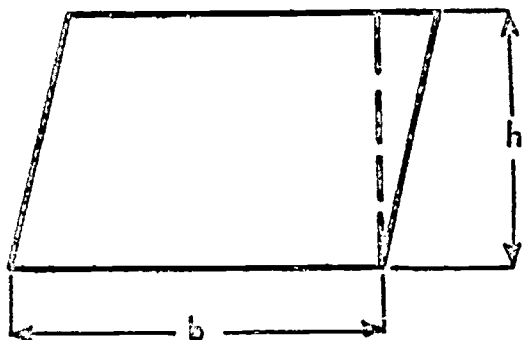

AREA OF A PARALLELOGRAM

$Area = b \times h$

where: b = parallel side
h = perpendicular distance between parallel sides b.

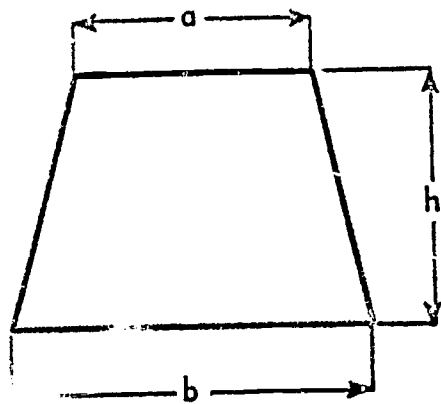

AREA OF A TRAPEZOID:

$Area = \frac{1}{2} (a + b) h.$

where: a & b = parallel sides
h = altitude

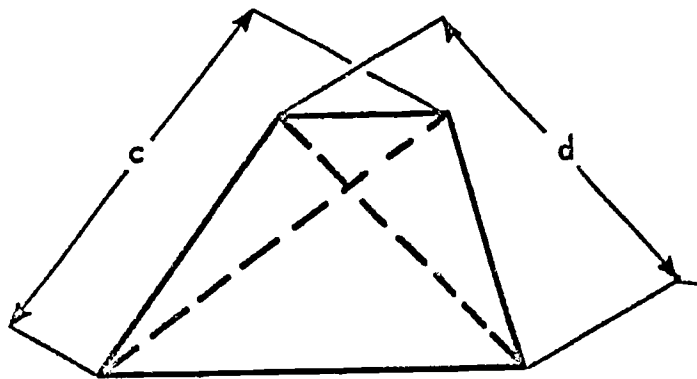

AREA OF A RHOMBUS:

$Area = \frac{1}{2} c d$

where: c & d are the diagonals

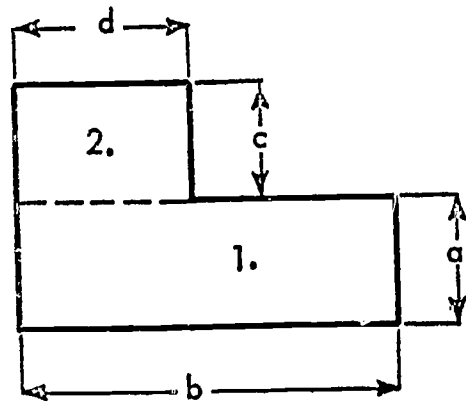

AREA OF "L" SHAPED ROOM:

$Area = Area 1. + Area 2.$

$Area = (a \times b) + (c \times d)$

The simplest method is to measure the walls of the type of room which is designated in the figure above.

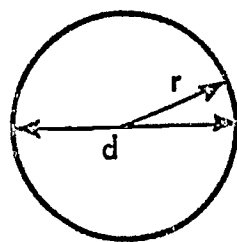

AREA OF A CIRCLE:

$(\pi = 3.14)$

$Area = \pi r^2 = \frac{1}{4} \pi d^2 = 0.7854 d^2$

where: r = radius of the circle
d = diameter of the circle

AREA OF A SEGMENT WHERE θ (THETA) IS THE ANGLE BETWEEN TWO RADII (IN RADIANS) AND TWO UNEQUAL CIRCLES.

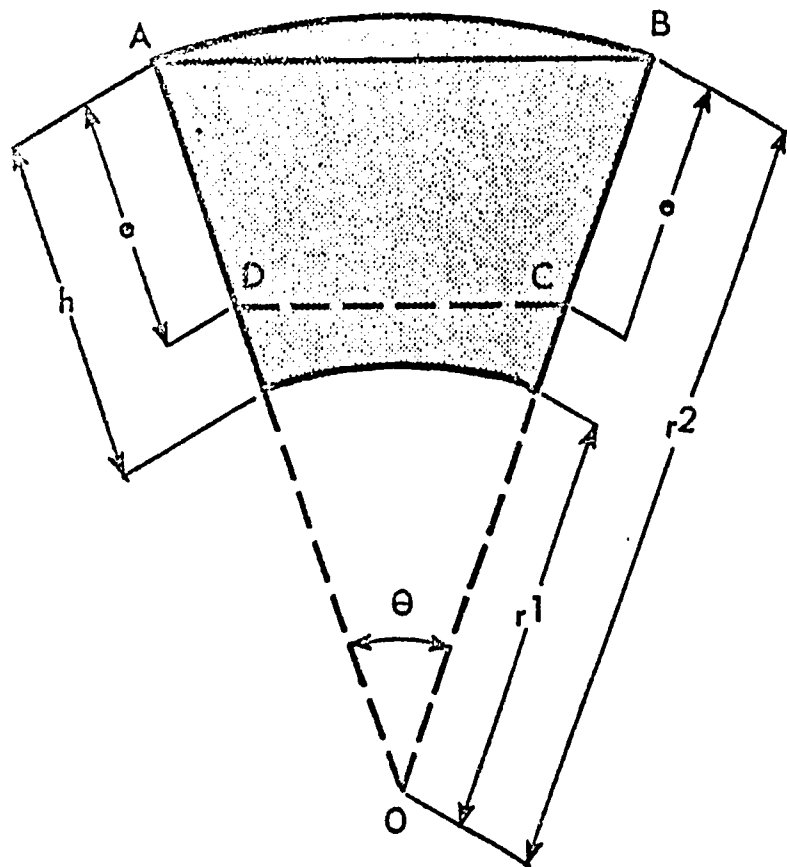

CONVERSION OF DEGREES TO RADIANS:

Any angle in radians is equal to π (π) times that angle in degrees divided by 180.

$$\theta \text{ (in radians)} = \frac{\pi \theta \text{ (in degrees)}}{180}$$

$$\text{Area} = \frac{1}{2} \theta (r_2 + r_1) (r_2 - r_1)$$

where:

r_2 = long radius

r_1 = short radius

h = difference of radii

STEP SOLUTION:

1. Measure "AB" and "h".
2. At any arbitrary distance "e" ("e" should be as long as possible) measure length "DC".
3. Make a scaled drawing. Extend "BC" and "AD" to the intersecting point "O".
4. Scale the length of "r2", "r1" and the angle "θ" from the drawing.
5. Convert "θ" (in degrees) to "θ" (in radians).
6. Substitute into the formula to get the total area of this segment.

**AREA OF A SECTOR
WHERE A CHORD
SUBTENDS AN ARC:**

This area may appear at the rear of an auditorium or lecture room.

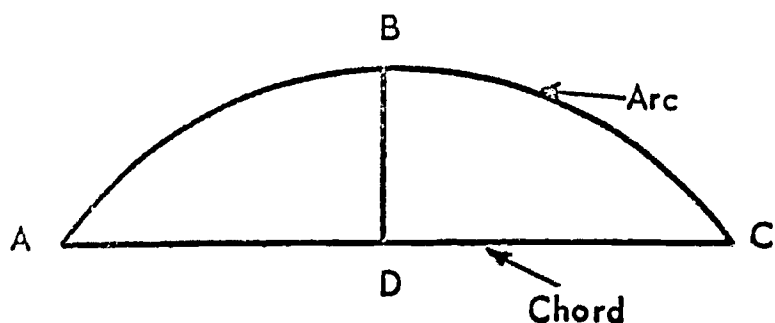

SOLUTION OF AREA:

STEP 1.

- a.) Measure the chord "AC".
- b.) Then divide length "AC" in half. So that; length "AD" = length "DC".
- c.) From point "D" on the chord "AC" measure the shortest distance to the curved wall "ABC", this distance will be equal to length "BD".

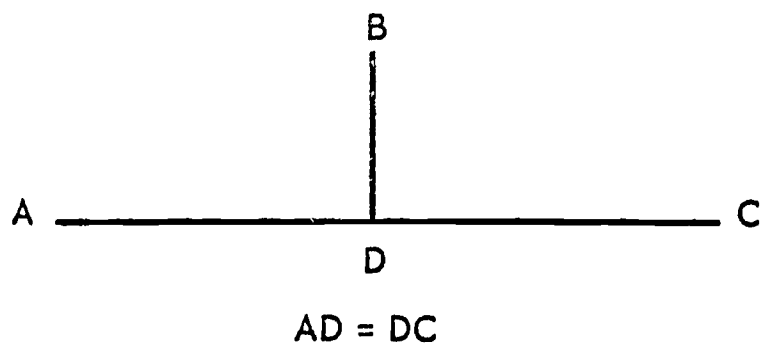

STEP 2.

For this step several drawing instruments are needed; an engineer's scale, a compass, pencil and eraser, a right triangle and a protractor.

- a.) Make a scaled drawing of lengths "ADC" and "BD".
- b.) Extend line "BD" with a light line making sure that line "BD" is at right-angles to chord "ADC", as indicated below.
- c.) Draw line "AB" lightly; divide line "AB" in half and designate this point as "E".
- d.) Draw a line through point "E" at right-angles to line "AB", where this line intersects with line "BD" extended is the center of the circle designated as point "O".
- e.) With a compass draw the arc "ABC"; also, draw the outside radii "AO" and "CO" of the pie shaped figure. Now, the area to be calculated lies between arc "ABC" and chord "ADC".

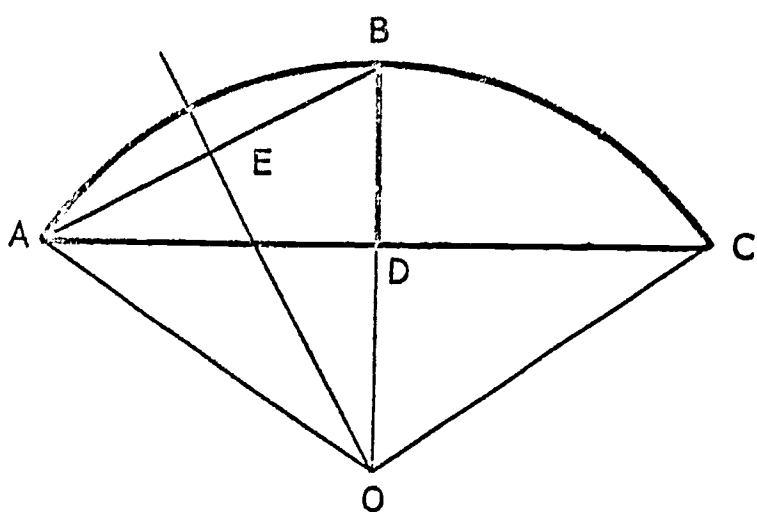

STEP 3.

- a.) Now, measure the length of the radii "AO", "BO", and "CO". This is an excellent check since these radii must be equal in length.

$$AO = BO = CO$$

- b.) When everything checks, record the lengths of the radii and the length of line "DO" on the drawing.

- c.) With a protractor, measure the angle "AOC" at point "O". This measurement is in degrees.

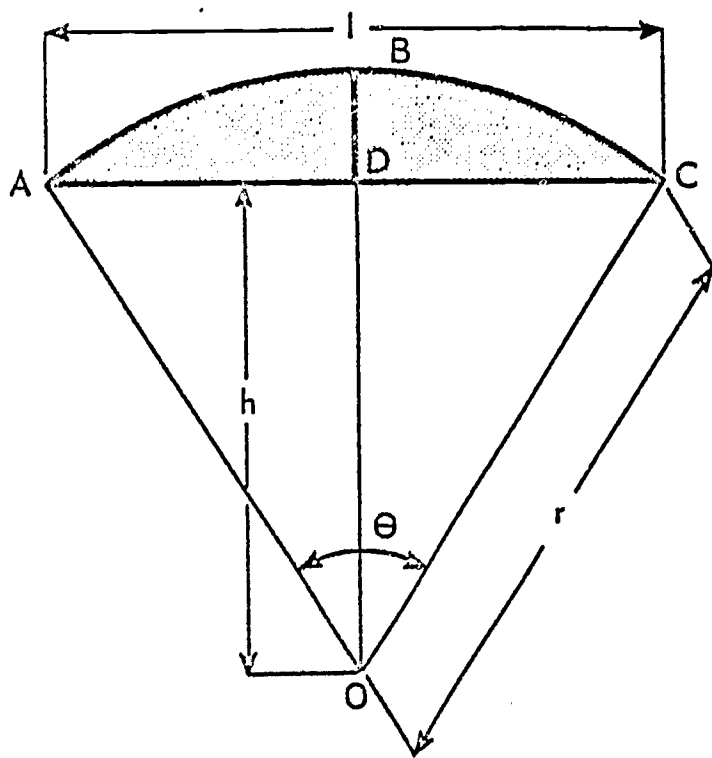

STEP 4.

- a.) To find the area cross-hatched, calculate the area of the entire pie shaped figure and subtract the area of the triangle "ACO".

Let: r = the radius
 h = the length "DO"
 l = the length "AC".
 θ (Theta) = the included angle "AOC".
 π (pi) = 3.14

$$\text{Area} = \text{Area of pie} - \text{Area of triangle "ACO"}.$$

$$\text{Area} = \frac{\pi r^2 \theta}{360} - \frac{1}{2} l h$$

TYPE OF STUDENT STATION CODE

Enter the type of Student Station Code for the following types of rooms only:

| | |
|-------------------------------|--------------------------------------|
| Lecture Rooms | Band, Choral, & Music Practice Rooms |
| Lecture - Demonstration Rooms | Language Laboratories |
| Seminar Rooms | Study Rooms |
| General Classrooms | Individual Study Stations |
| Teaching Laboratories | Library Stocks |
| Instructional Shops | Open Stack Reading Rooms |
| Typing Laboratories | Assembly Facilities |
| Drafting Rooms | |

| <u>Code</u> | <u>Description</u> |
|-------------|--|
| 00 | Fixed Chair, With Tablet Arm |
| 01 | Moveable Chair, With Tablet Arm |
| 02 | Straight Back Chair, With Or Without Arm Rests |
| 03 | Table-Chair Combinations (Seminar, Conference Room-Type Seating) |
| 04 | Desk-Chair Combination |
| 05 | Bench-Type Seating (Gymnasium Stands, Etc.) |
| 06 | Theatre Seating |
| 07 | Lounge Chair, Sofa, Or Other Cushioned Seating |
| 08 | Stool-Type Seating |
| 09 | Teaching Laboratory Station |
| 10 | Individual Study Stations (Carrels) |

INSTITUTIONAL ROOM INVENTORY BY BUILDING

SHEET _____ OF _____

| | | | | |
|------------------|------------------|------------------|----------------|-----------------|
| INSTITUTION CODE | INSTITUTION NAME | FORM PREPARED BY | INVENTORY DATE | BUILDING NUMBER |
|------------------|------------------|------------------|----------------|-----------------|

| ROOM | | | | | | | | | | | | | | | | | | | | | | | | | | | STATIONS | | | | | | REMARKS |
|--------|----|----|----|----|----|----|----------|----|------|----|----|-----------|----|------------------------|----|----|----|----|----|---------|----|----|-----------|----|----|-----------------|-----------|----|----|----|--|--|---------|
| NUMBER | | | | | | | FUNCTION | | TYPE | | | CONDITION | | ASSIGNABLE SQUARE FEET | | | | | | NUMBER | | | | | | TYPE INST. CODE | MULT. USE | | | | | | |
| | | | | | | | | | | | | | | | | | | | | OPTIMUM | | | INSTALLED | | | | | | | | | | |
| 10 | 11 | 12 | 13 | 14 | 15 | 16 | 17 | 18 | 19 | 20 | 21 | 22 | 23 | 24 | 25 | 26 | 27 | 28 | 29 | 30 | 31 | 32 | 33 | 34 | 35 | 36 | 37 | 38 | 39 | 40 | | | |
| | | | | | | | | | | | | | | | | | | | | | | | | | | | | | | | | | |
| | | | | | | | | | | | | | | | | | | | | | | | | | | | | | | | | | |
| | | | | | | | | | | | | | | | | | | | | | | | | | | | | | | | | | |
| | | | | | | | | | | | | | | | | | | | | | | | | | | | | | | | | | |
| | | | | | | | | | | | | | | | | | | | | | | | | | | | | | | | | | |
| | | | | | | | | | | | | | | | | | | | | | | | | | | | | | | | | | |
| | | | | | | | | | | | | | | | | | | | | | | | | | | | | | | | | | |
| | | | | | | | | | | | | | | | | | | | | | | | | | | | | | | | | | |
| | | | | | | | | | | | | | | | | | | | | | | | | | | | | | | | | | |
| | | | | | | | | | | | | | | | | | | | | | | | | | | | | | | | | | |
| | | | | | | | | | | | | | | | | | | | | | | | | | | | | | | | | | |
| | | | | | | | | | | | | | | | | | | | | | | | | | | | | | | | | | |
| | | | | | | | | | | | | | | | | | | | | | | | | | | | | | | | | | |
| | | | | | | | | | | | | | | | | | | | | | | | | | | | | | | | | | |
| | | | | | | | | | | | | | | | | | | | | | | | | | | | | | | | | | |
| | | | | | | | | | | | | | | | | | | | | | | | | | | | | | | | | | |
| | | | | | | | | | | | | | | | | | | | | | | | | | | | | | | | | | |
| | | | | | | | | | | | | | | | | | | | | | | | | | | | | | | | | | |
| | | | | | | | | | | | | | | | | | | | | | | | | | | | | | | | | | |
| | | | | | | | | | | | | | | | | | | | | | | | | | | | | | | | | | |
| | | | | | | | | | | | | | | | | | | | | | | | | | | | | | | | | | |
| | | | | | | | | | | | | | | | | | | | | | | | | | | | | | | | | | |
| | | | | | | | | | | | | | | | | | | | | | | | | | | | | | | | | | |
| | | | | | | | | | | | | | | | | | | | | | | | | | | | | | | | | | |
| | | | | | | | | | | | | | | | | | | | | | | | | | | | | | | | | | |
| | | | | | | | | | | | | | | | | | | | | | | | | | | | | | | | | | |
| | | | | | | | | | | | | | | | | | | | | | | | | | | | | | | | | | |
| | | | | | | | | | | | | | | | | | | | | | | | | | | | | | | | | | |
| | | | | | | | | | | | | | | | | | | | | | | | | | | | | | | | | | |
| | | | | | | | | | | | | | | | | | | | | | | | | | | | | | | | | | |
| | | | | | | | | | | | | | | | | | | | | | | | | | | | | | | | | | |
| | | | | | | | | | | | | | | | | | | | | | | | | | | | | | | | | | |
| | | | | | | | | | | | | | | | | | | | | | | | | | | | | | | | | | |
| | | | | | | | | | | | | | | | | | | | | | | | | | | | | | | | | | |
| | | | | | | | | | | | | | | | | | | | | | | | | | | | | | | | | | |
| | | | | | | | | | | | | | | | | | | | | | | | | | | | | | | | | | |
| | | | | | | | | | | | | | | | | | | | | | | | | | | | | | | | | | |
| | | | | | | | | | | | | | | | | | | | | | | | | | | | | | | | | | |

INSTITUTIONAL BUILDING

INSTITUTION CODE

INSTITUTION NAME

BUILDING

| NUMBER | BUILDING | | | | | | | | | | | | | | | | | | | | | | | | | | | | | C O N S T. T Y P E | NO. OF FLOORS | | C O N D I T I O N | EST'D USEFUL LIFE IN YEARS AT THIS DATE | | GROSS AREA IN SQUARE FEET | | | | | | O W N E R S H I P | | | | | | | | | | | | | | | | | | | | | | | | | | | |
|--------|------------------|---|----|----|----|----|----|----|----|----|----|----|----|----|----|----|----|----|----|----|----|----|----|----|----|----|----|----|----|--|---------------------|----|---|--|----|------------------------------------|--|--|--|--|--|---|--|--|--|--|--|--|--|--|--|--|--|--|--|--|--|--|--|----|----|----|----|----|----|----|----|----|----|
| | ABBREVIATED NAME | | | | | | | | | | | | | | | | | | | | | | | | | | | | | | FUNCTIONAL TYPE | | | | | | | | | | | | | | | | | | | | | | | | | | | | | 31 | 32 | 34 | 35 | 36 | 37 | 38 | 39 | 40 | 41 |
| 7 | 8 | 9 | 10 | 11 | 12 | 13 | 14 | 15 | 16 | 17 | 18 | 19 | 20 | 21 | 22 | 23 | 24 | 25 | 26 | 27 | 28 | 29 | 30 | 31 | 32 | 33 | 34 | 35 | 36 | 37 | 38 | 39 | 40 | 41 | 42 | 43 | | | | | | | | | | | | | | | | | | | | | | | | | | | | | | | | | |
| | | | | | | | | | | | | | | | | | | | | | | | | | | | | | | | | | | | | | | | | | | | | | | | | | | | | | | | | | | | | | | | | | | | | | |
| | | | | | | | | | | | | | | | | | | | | | | | | | | | | | | | | | | | | | | | | | | | | | | | | | | | | | | | | | | | | | | | | | | | | | |

ING INVENTORY DOCUMENT

SHEET _____ OF _____

| | | | |
|--|---------------------|------------------|----------------|
| | FACILITIES RECORDER | BUSINESS OFFICER | INVENTORY DATE |
|--|---------------------|------------------|----------------|

| YEAR OF INITIAL OCCUPANCY | FINANCIAL DATA | | | | | | | | | | | | | | | | | | | | | REMARKS | | | | | | |
|---------------------------|---------------------------------|----|----|----|----|------|-----|---------------------|----|----|-------------------------------|--------|---------------------|----|----|----|----|--|----|----|----|---------|----|----|----|----|----|----|
| | TOTAL ACTUAL CAPITAL INVESTMENT | | | | | | | | | | FURNISHINGS COST IN THOUSANDS | SOURCE | FUNDS | | | | | ESTIMATED REPLACEMENT VALUE IN THOUSANDS | | | | | | | | | | |
| | AMOUNT IN THOUSANDS | | | | | DATE | | AMOUNT IN THOUSANDS | | | | | AMOUNT IN THOUSANDS | | | | | | | | | | | | | | | |
| | | | | | | MO. | YR. | | | | | | | | | | | | | | | | | | | | | |
| 43 | 44 | 45 | 46 | 47 | 48 | 49 | 50 | 51 | 52 | 53 | 54 | 55 | 56 | 57 | 58 | 59 | 60 | 61 | 62 | 63 | 64 | 65 | 66 | 67 | 68 | 69 | 70 | 71 |
| | | | | | | | | | | | | | | | | | | | | | | | | | | | | |
| | | | | | | | | | | | | | | | | | | | | | | | | | | | | |
| | | | | | | | | | | | | | | | | | | | | | | | | | | | | |
| | | | | | | | | | | | | | | | | | | | | | | | | | | | | |
| | | | | | | | | | | | | | | | | | | | | | | | | | | | | |
| | | | | | | | | | | | | | | | | | | | | | | | | | | | | |
| | | | | | | | | | | | | | | | | | | | | | | | | | | | | |
| | | | | | | | | | | | | | | | | | | | | | | | | | | | | |
| | | | | | | | | | | | | | | | | | | | | | | | | | | | | |
| | | | | | | | | | | | | | | | | | | | | | | | | | | | | |
| | | | | | | | | | | | | | | | | | | | | | | | | | | | | |
| | | | | | | | | | | | | | | | | | | | | | | | | | | | | |
| | | | | | | | | | | | | | | | | | | | | | | | | | | | | |
| | | | | | | | | | | | | | | | | | | | | | | | | | | | | |
| | | | | | | | | | | | | | | | | | | | | | | | | | | | | |
| | | | | | | | | | | | | | | | | | | | | | | | | | | | | |
| | | | | | | | | | | | | | | | | | | | | | | | | | | | | |
| | | | | | | | | | | | | | | | | | | | | | | | | | | | | |
| | | | | | | | | | | | | | | | | | | | | | | | | | | | | |
| | | | | | | | | | | | | | | | | | | | | | | | | | | | | |
| | | | | | | | | | | | | | | | | | | | | | | | | | | | | |
| | | | | | | | | | | | | | | | | | | | | | | | | | | | | |
| | | | | | | | | | | | | | | | | | | | | | | | | | | | | |
| | | | | | | | | | | | | | | | | | | | | | | | | | | | | |
| | | | | | | | | | | | | | | | | | | | | | | | | | | | | |

