

R E P O R T R E S U M E S

ED 021 124

VT 005 707

AUTOMOTIVE DIESEL MAINTENANCE 2. UNIT XXIII, MICHIGAN/CLARK
TRANSMISSION--HYDRAULIC SHIFT.

HUMAN ENGINEERING INSTITUTE, CLEVELAND, OHIO

REPORT NUMBER AM-2-23

PUB DATE 25 SEP 67

MINNESOTA STATE DEPT. OF EDUCATION, ST. PAUL

EDRS PRICE MF-\$0.25 HC-\$1.88 45P.

DESCRIPTORS- *STUDY GUIDES, *TEACHING GUIDES, *TRADE AND
INDUSTRIAL EDUCATION, *AUTO MECHANICS (OCCUPATION),
*EQUIPMENT MAINTENANCE, DIESEL ENGINES, ADULT VOCATIONAL
EDUCATION, TRANSPARENCIES, PROGRAMED MATERIALS, INDIVIDUAL
INSTRUCTION, INSTRUCTIONAL FILMS, PROGRAMED INSTRUCTION,
KINETICS, MOTOR VEHICLES,

THIS MODULE OF A 25-MODULE COURSE IS DESIGNED TO DEVELOP
AN UNDERSTANDING OF THE SHIFTING AND CONTROL FUNCTIONS OF A
SPECIFIC TRANSMISSION USED ON DIESEL POWERED EQUIPMENT.
TOPICS ARE MECHANICAL AND HYDRAULIC SHIFTING, AND OIL FLOW
THROUGH THE CONTROL VALVE. THE MODULE CONSISTS OF A
SELF-INSTRUCTIONAL PROGRAMED TRAINING FILM "MICHIGAN/CLARK
TRANSMISSION--MECHANICAL AND HYDRAULIC SHIFT AND OIL FLOW
THROUGH THE VALVES AND CONTROL COVER ASSEMBLY" AND OTHER
MATERIALS. SEE VT 005 685 FOR FURTHER INFORMATION. MODULES IN
THIS SERIES ARE AVAILABLE AS VT 005 685 - VT 005 709. MODULES
FOR "AUTOMOTIVE DIESEL MAINTENANCE 1" ARE AVAILABLE AS VT 005
655 - VT 005 684. THE 2-YEAR PROGRAM OUTLINE FOR "AUTOMOTIVE
DIESEL MAINTENANCE 1 AND 2" IS AVAILABLE AS VT 006 006. THE
TEXT MATERIAL, TRANSPARENCIES, PROGRAMED TRAINING FILM, AND
THE ELECTRONIC TUTOR MAY BE RENTED (FOR \$1.75 PER WEEK) OR
PURCHASED FROM THE HUMAN ENGINEERING INSTITUTE, HEADQUARTERS
AND DEVELOPMENT CENTER, 2341 CARNEGIE AVENUE, CLEVELAND, OHIO
44115. (HC)

STUDY AND READING MATERIALS

AUTOMOTIVE DIESEL MAINTENANCE

2

MICHIGAN/CLARK TRANSMISSION --
HYDRAULIC SHIFT

UNIT XXIII

SECTION A

MECHANICAL AND
HYDRAULIC SHIFTING

SECTION B

OIL FLOW THROUGH
THE CONTROL VALVE

U.S. DEPARTMENT OF HEALTH, EDUCATION & WELFARE
OFFICE OF EDUCATION

THIS DOCUMENT HAS BEEN REPRODUCED EXACTLY AS RECEIVED FROM THE
PERSON OR ORGANIZATION ORIGINATING IT. POINTS OF VIEW OR OPINIONS
STATED DO NOT NECESSARILY REPRESENT OFFICIAL OFFICE OF EDUCATION
POSITION OR POLICY.

AM 2-23
9/25/67

Human Engineering
Institute

Minn. State Dept. of Ed.
Vocational Education

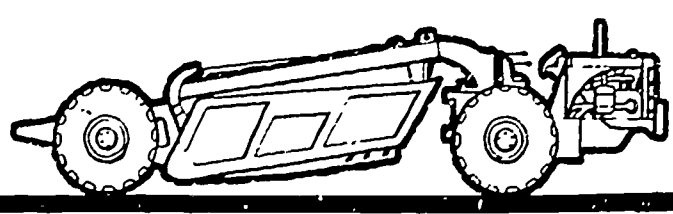
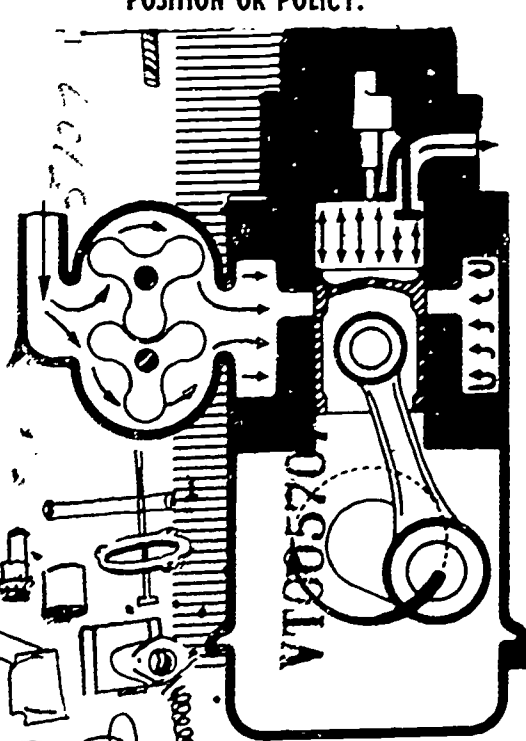
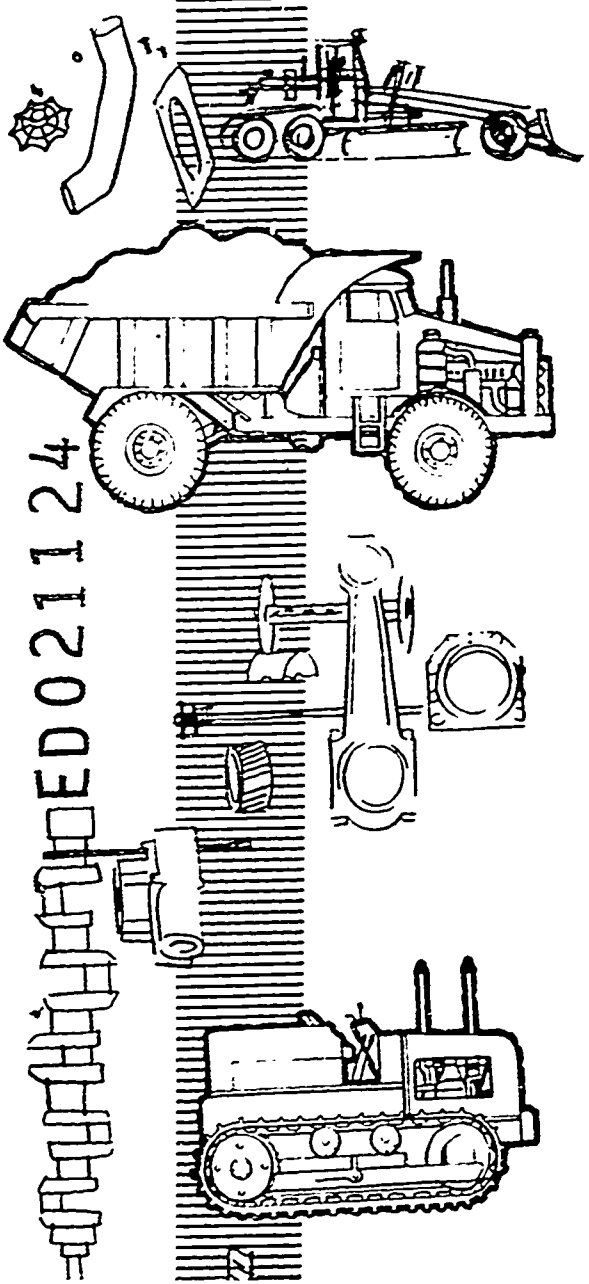

HUMAN ENGINEERING INSTITUTE

SECTION A -- MECHANICAL AND HYDRAULIC SHIFTING

HYDRAULIC SHIFTING -- Notice in Figure 1 that there are two control levers: the DIRECTIONAL SHIFT LEVER, and the SPEED RANGE LEVER. Both controls are mounted on the steering column in the operator's cab. Through the use of a control valve, hoses, and a steady pressure, most of the mechanical linkage can be eliminated where the speed ranges are concerned. The forward-reverse lever (directional shift lever), however, is entirely mechanically linked from the steering column to the transmission.

SPEED RANGE CONTROL -- Pressure, directed to the shift control valve from a clutch pressure port, is redirected through guides in the valve, and through hoses (to the transmission) which serve to shift the range selector and speed selector spools. See Figure 2.

The speed range lever is the bottom lever on the steering column. It has eight positions for the eight speeds forward. The speed range lever is connected to the shift control valve, located under the floor board, by a control rod and an adjustable clevis. See Figure 1. The detent stops for each position of the speed range lever are located in the shift control valve.

CONTROL VALVE FUNCTION -- The function of the shift control valve is to hydraulically position a combination of valve spools (in the transmission control cover) in positions that correspond to the position of the speed range lever. This permits the valve spools to direct oil pressure from the converter pump to the appropriate clutches in the transmission, engaging the transmission in the speed range selected by the operator.

DIRECTIONAL CONTROL LEVER FUNCTION -- The directional control lever is the top lever located on the steering column. This lever has three positions. Forward (away from the operator) will shift the directional spool in the transmission control cover to the forward position.

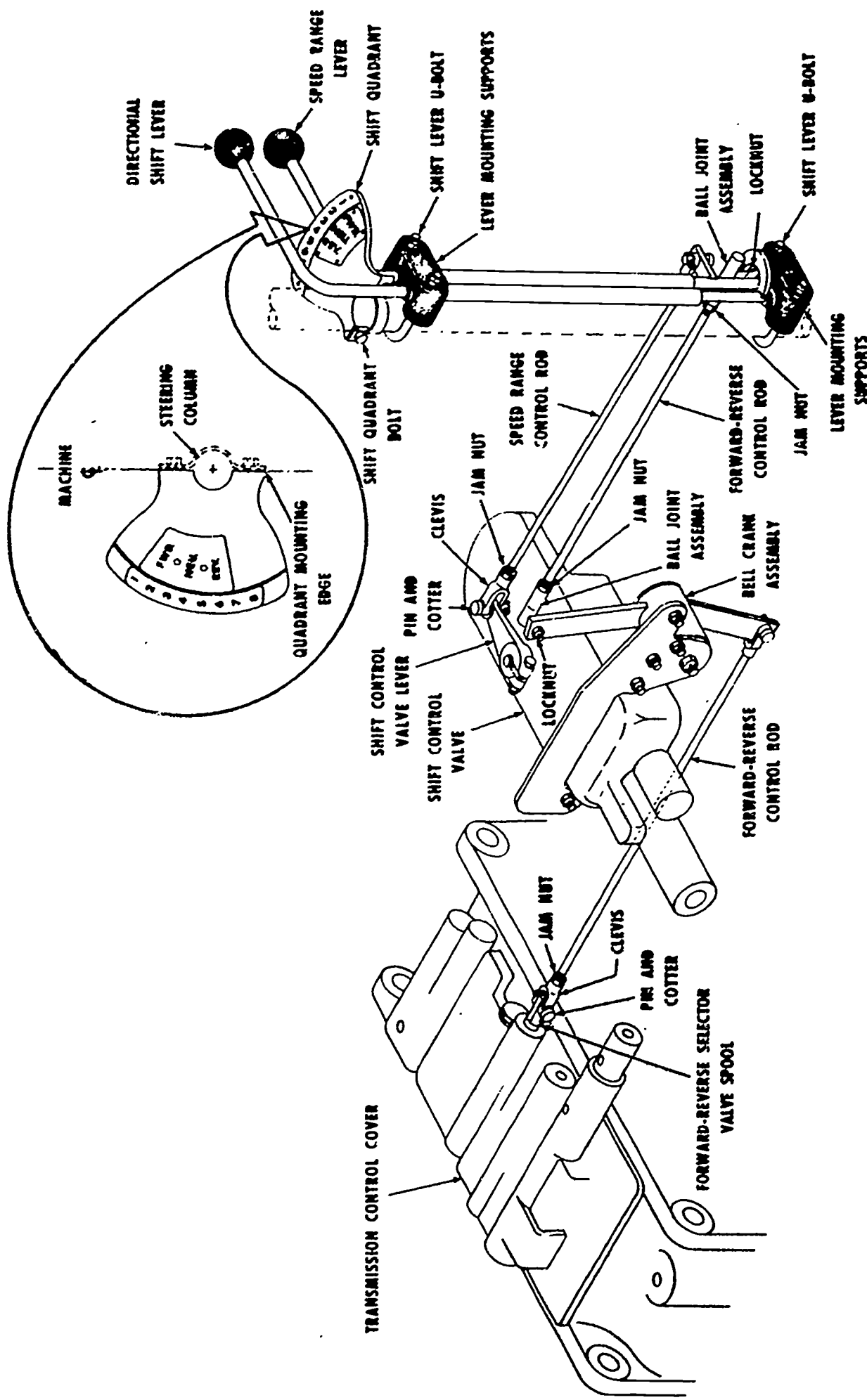
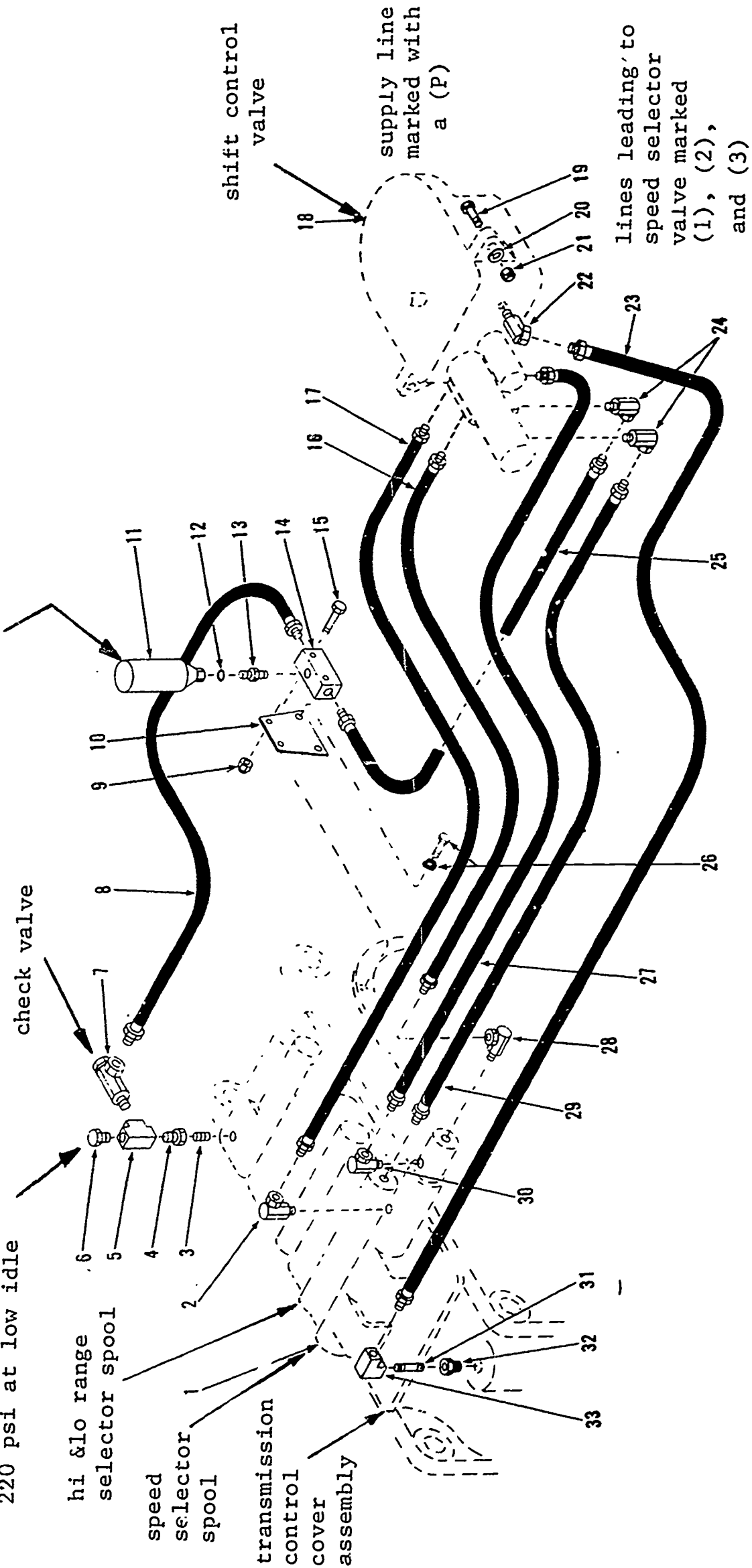

Fig. 1 Mechanical and hydraulic linkage

accumulator-pre-charge to 100 psi + or
 - 10 psi with no pressure in shift
 control system

clutch pressure port-180 to
 220 psi at low idle



AM 2-23

range line is
 marked (H-L)

Fig. 2 Hydraulic connections

Pulling back toward the operator causes the directional spool to go into neutral. Pulling back to the end of lever travel will cause the directional spool to go into reverse position. The directional lever is connected to the directional spool on the transmission by control rods, a bellcrank and an adjustable clevis.

NOTE: Refer to Figure 2 when reading the following paragraphs.

Clutch oil pressure (tapped from the clutch pressure port in the transmission control cover) passes through a check valve to the accumulator. The check valve prevents the oil in the shift control system from flowing backwards toward the clutch pressure port. Clutch pressure will drop when shifting from one clutch to another; the check valve holds the oil in the shift control system when this occurs. The accumulator stores a supply of oil under pressure, so that the shift control system has a constant oil supply. This constant pressure is needed to insure smooth, quick shifts from one gear to the next. From the accumulator, the oil pressure goes through a hose to the shift control valve.

Oil passes from the shift control valve to the speed selector valve in the transmission through three hoses. There is a marking -- (1), (2), or (3) where each hose connects to the speed selector valve and to the shift control valve. These hoses are named hose "one", hose "two" and hose "three". Oil passes from the shift control valve to the range control valve (in the transmission control cover) through hose "one". Only the shift control valve has a marking of (H-L) where this hose connects. There is no marking on the range control valve.

Pressure in the hoses (when the speed range lever is shifted into different speeds) can best be explained in the following table.

<u>LEVER POSITION AND GEAR</u>	<u>HOSES THAT HAVE PRESSURE IN THEM</u>
1st	1, 2, 3
2nd	1, 2, 3 Range
3rd	2, 3
4th	2, 3 Range
5th	3
6th	3, Range
7th	None
8th	Range

Table I Lever positions

SPOOL MOVEMENT OIL PRESSURE -- Keep in mind that the clutch pressure oil in the shift control system hoses does not go to a clutch in order to engage that clutch. Oil pressure in these hoses is for the specific purpose of moving the spools on the transmission control cover. Movement of these spools directs other oil pressure to the desired clutches. Oil pressure is relieved in the different hoses when shifting the speed range lever. The oil that is relieved from the hoses flows into the shift control main housing and on to the transmission sump through a drain line.

SECTION B -- OIL FLOW THROUGH THE CONTROL VALVE

NOTE: In the following paragraphs and illustrations, each range will be discussed by tracing the oil flow in all eight positions. Illustrations can be found at the end of this section.

Figure 3 shows the shift control valve in first gear position or first reverse. To obtain reverse gear ratios, the shift control valve must only shift the speed selector valve in the transmission. When the directional lever is in reverse, there will be no oil pressure going to the range spool from the

pump through the transmission control cover. Even though the shift control valve moves the range spool from high forward clutch position to low forward clutch position, it will not affect reverse ratios in the transmission.

There is pressure in hoses (1), (2) and (3). The range hose is draining off, up through the drilled passage in the spool, into the main housing and out the drain line to the transmission.

Figure 4 shows the shift control valve in second gear position or first reverse. There is pressure in hoses (1), (2), (3) and in the range hose. In second gear, all four hoses have pressure in them.

Figure 5 shows the shift control valve in third gear position or second reverse. There is pressure in hoses (2) and (3). Hose (1) pressure is draining off around the spool, and the range hose is draining off through the drilled passage in the spool. Both hoses drain into the main housing and on to the transmission through the drain hose.

Figure 6 shows the shift control valve in fourth gear position or second reverse. There is pressure in hoses (2), (3) and in the range hose. Pressure in hose (1) is draining off.

Figure 7 shows the shift control valve in fifth gear position or third reverse. There is pressure in hose (3) only. Hoses (1), (2), and the range hose are draining off.

Figure 8 shows the shift control valve in sixth gear position or third reverse. There is pressure in hose (3) and in the range hose. Hoses (1) and (2) are draining off.

Figure 9 shows the shift control valve in seventh gear position or fourth reverse. There is no pressure in hoses (1), (2), (3) or in the range hose. They are all draining off.

AM 2-23

Figure 10 shows the shift control valve in eighth gear position or fourth reverse. There is pressure in the range hose. Hoses (1), (2) and (3) are draining off.

shift control valve shown in 1st gear

the directional spool can be in either forward or reverse direction

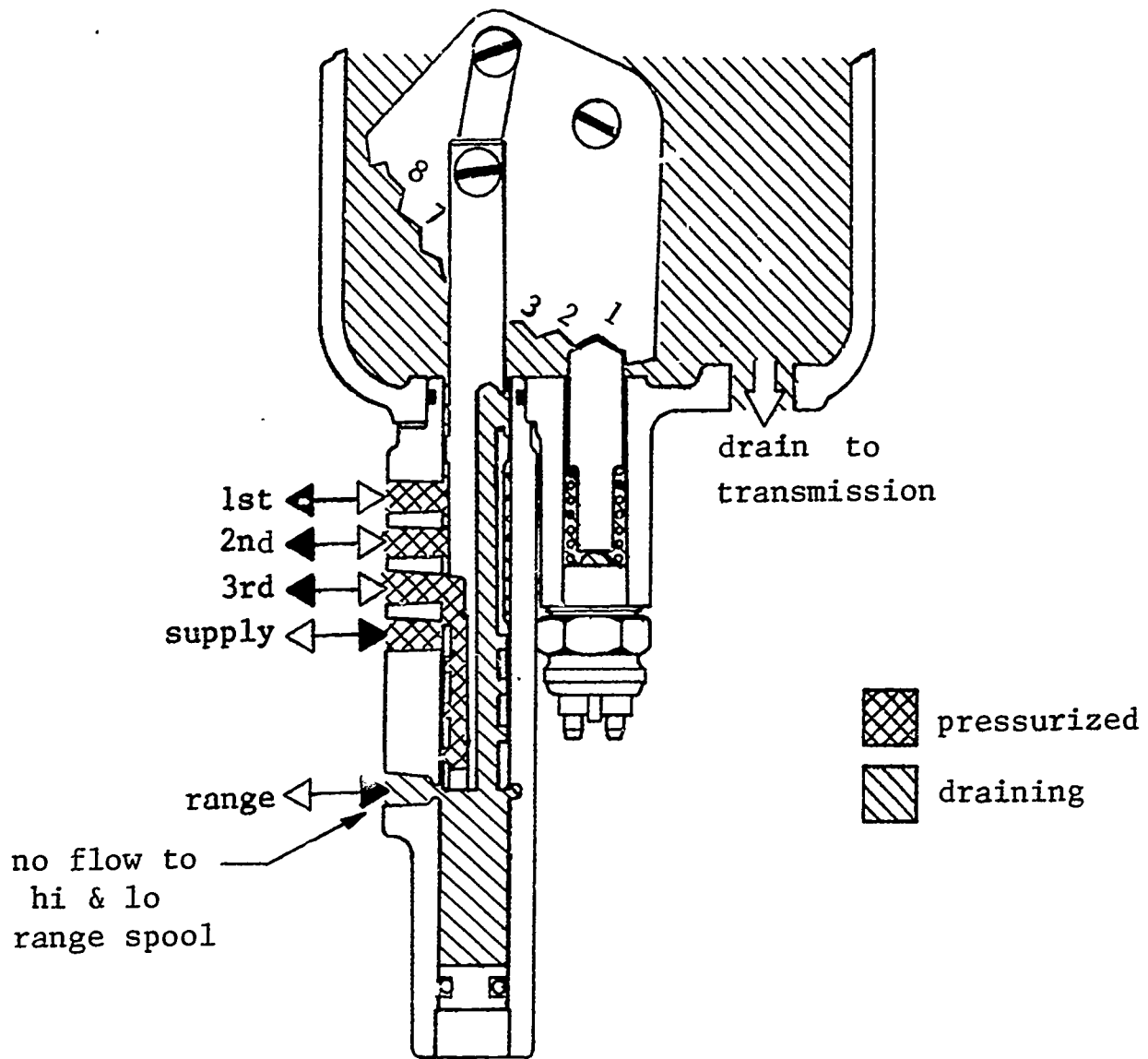
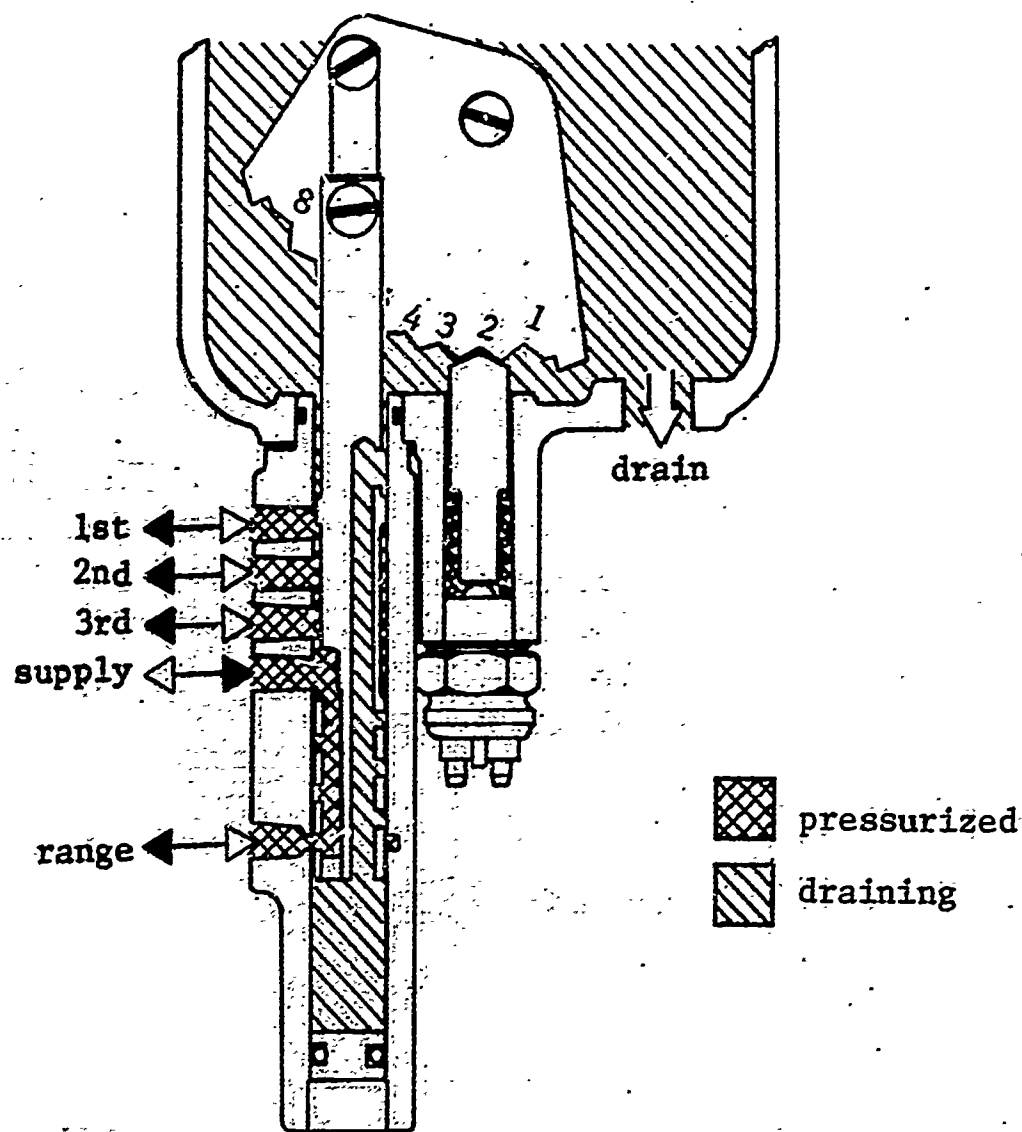

Fig. 3 Control valve in first gear

shift control valve shown in 2nd gear

there is pressure in line 1,2,3 and the range line



you will note all lines are supplied with oil

2nd gear is the only time they are all supplied and 7th gear is when they are all shut off

Fig. 4 Control valve in second gear

shift control valve shown in
3rd gear position

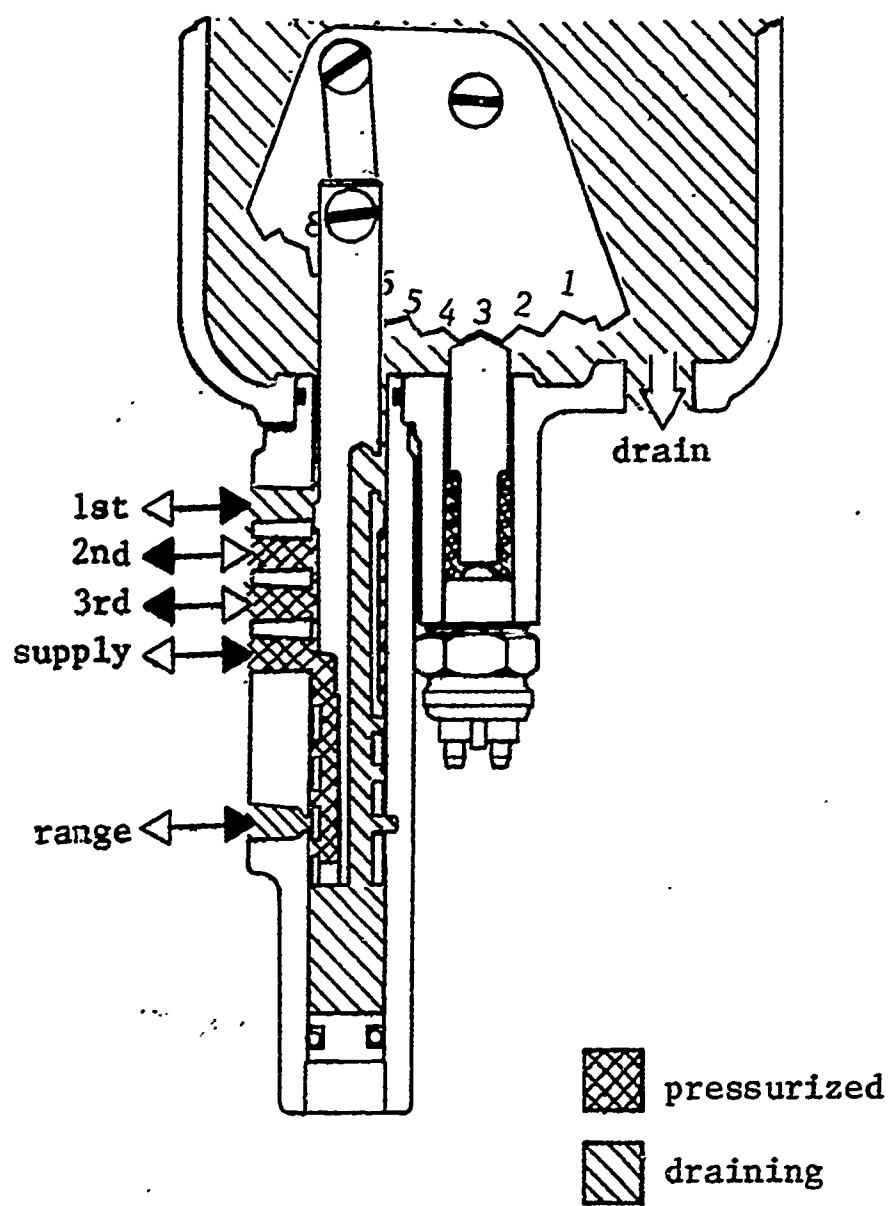

Fig. 5 Control valve in third gear

shift control valve is shown in
4th gear position

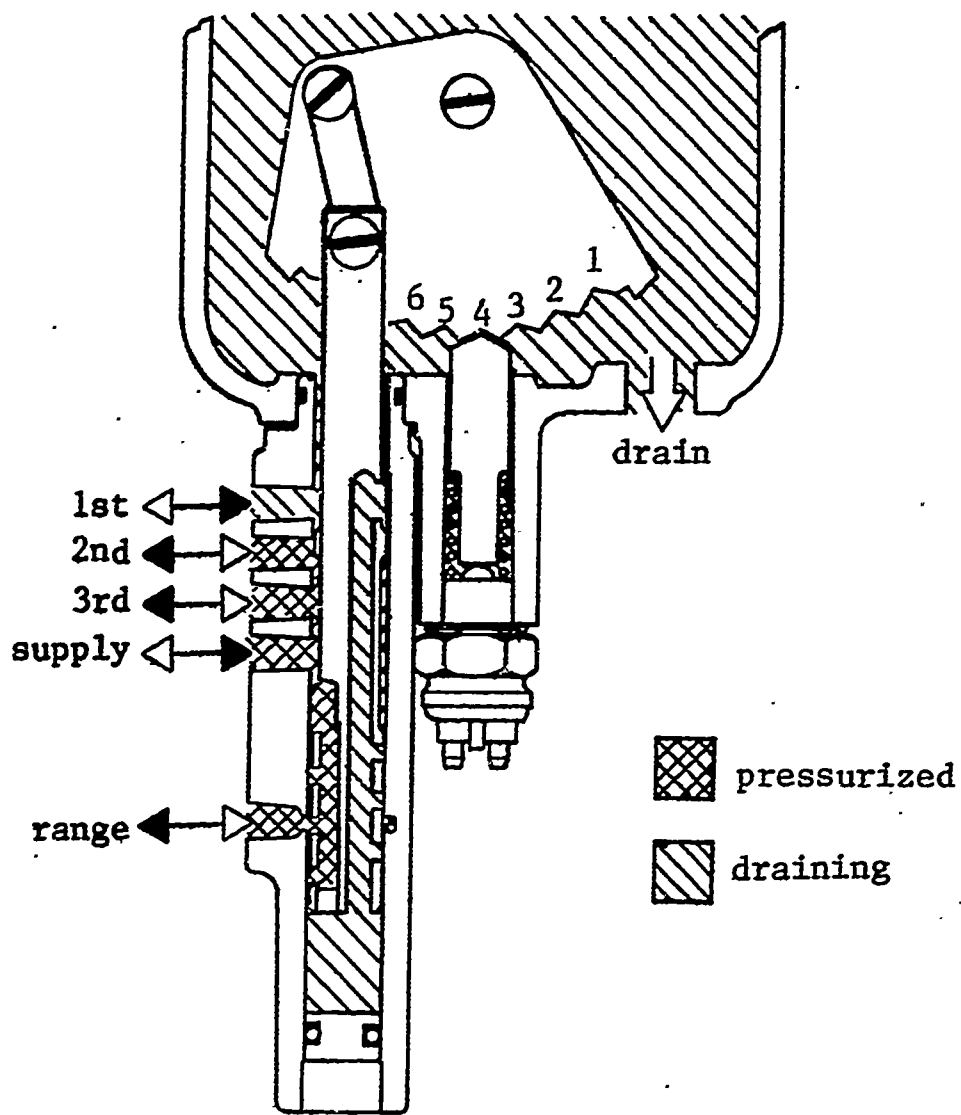

Fig. 6 Control valve in fourth gear

shift control valve is shown
in 5th gear position

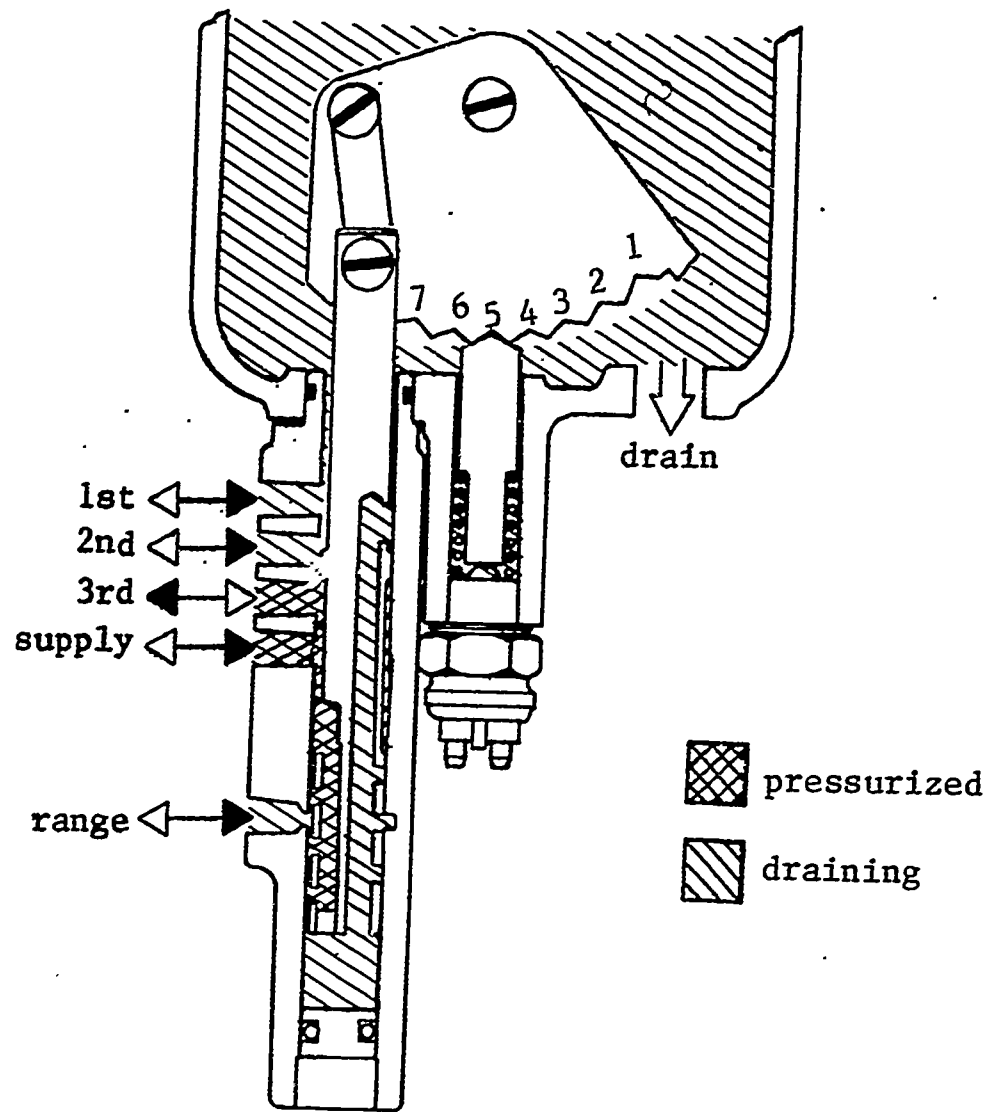

Fig. 7 Control valve in fifth gear

shift control valve is shown
in 6th gear position

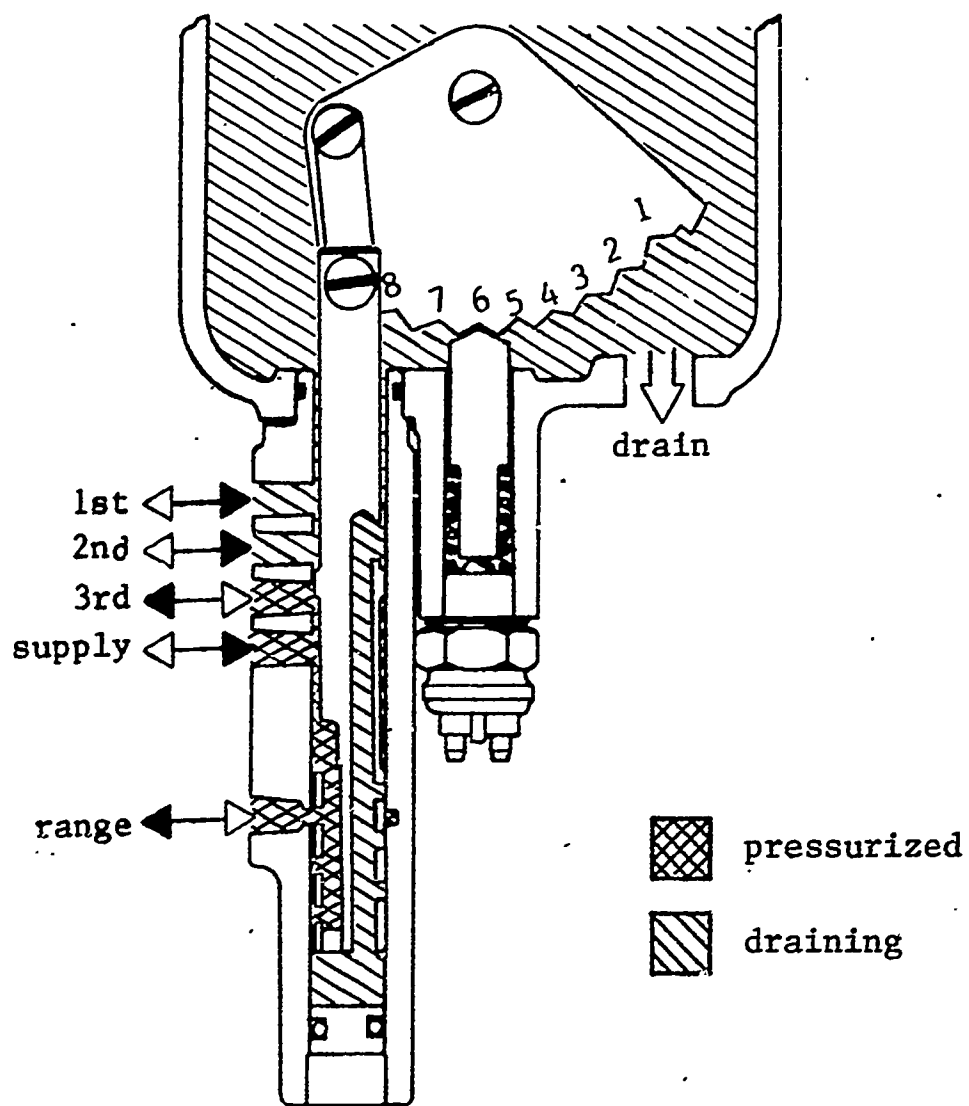

Fig. 8 Control valve in sixth gear

shift control valve is shown
7th gear position

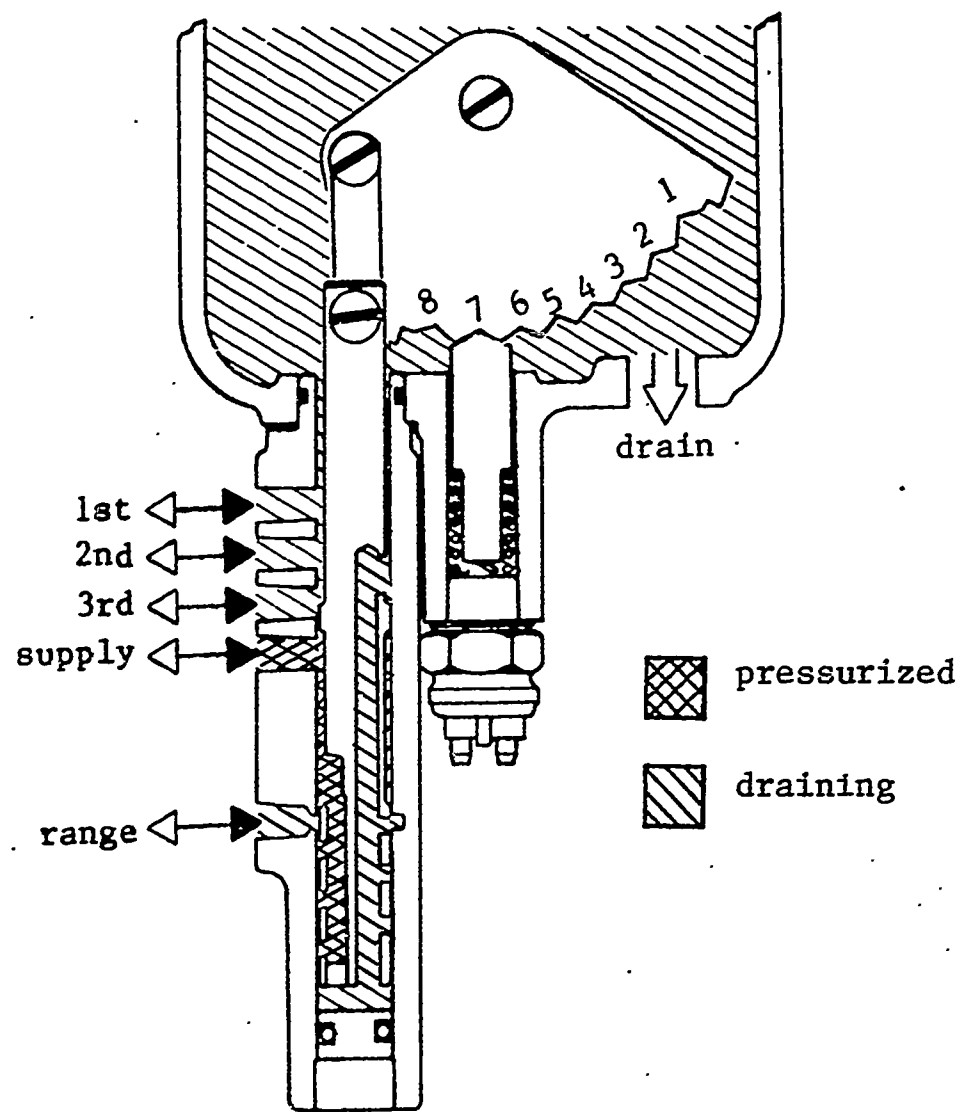

Fig. 9 Control valve in seventh gear

shift control valve is shown
in 8th gear position

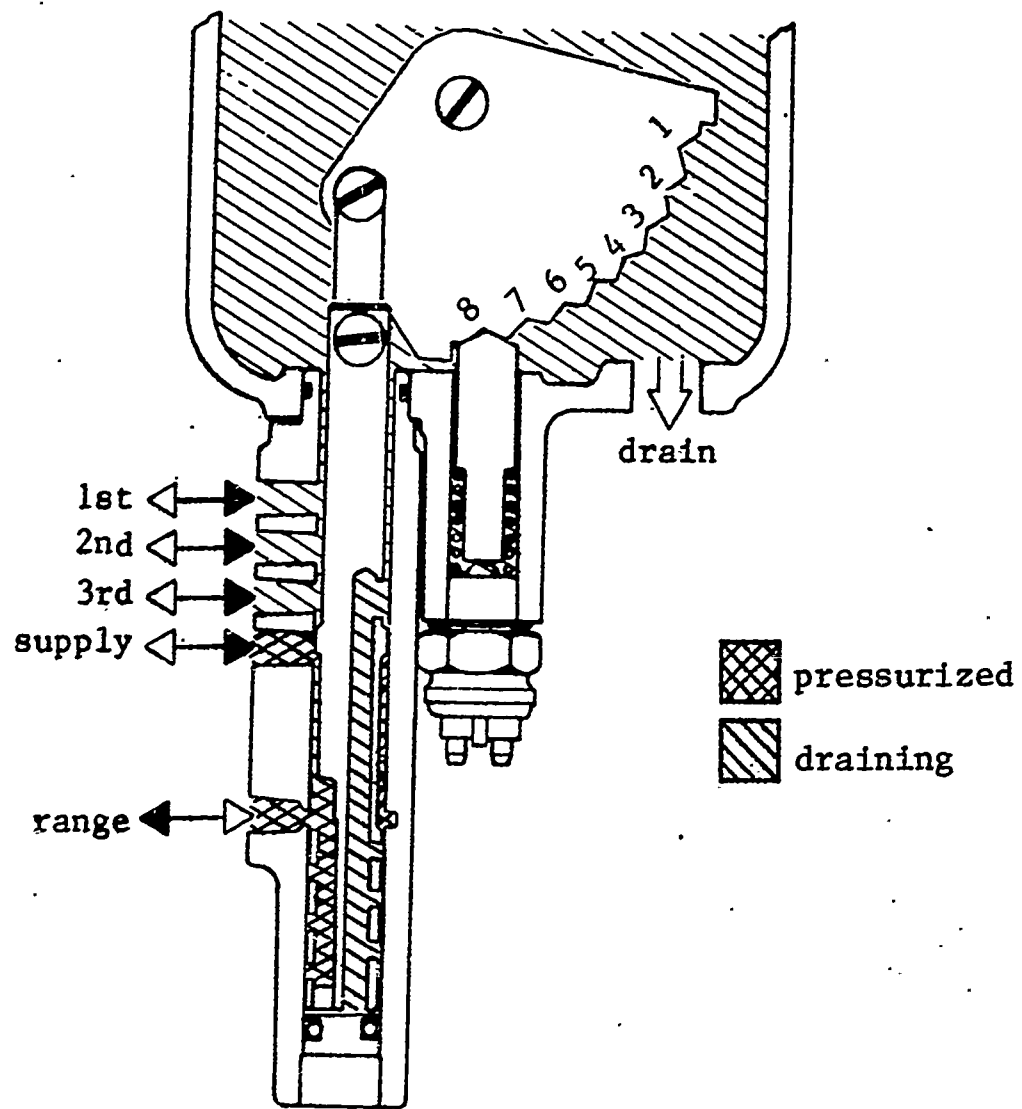

Fig. 10 Control valve in eighth gear

SHIFT CONTROL VALVE DISASSEMBLED -- Figure 11 shows a parts breakdown of the shift control valve. The speed range lever, located on the steering column, is connected to a cam with eight detents, item No. 6. The detent stop consists of items 13 and 14. There is a microswitch holding the detent spring in position. This microswitch is used for vehicles with lock-up in the converter; The switch prevents any shifting of the transmission when the converter is in lock-up.

The two holes visible in item No. 22 are the holes for hoses (1) and (3). The spool housing, item 22, is held to a spacing that provides sufficient spool sealing by shims, item No. 26.

During re-assembly, there are two important items to remember;

- (1) Be sure that the same number of shims are replaced that were removed, and
- (2) Position the shift control valve in the 8th gear position. When looking in the supply hole, the spool land should be covering half the hole.

Figure 12 shows a parts breakdown of the transmission control cover. The function of the hydraulically shifted control cover is the same as for the mechanically shifted cover. The only difference is that the speed selector spool and range selector spool are moved either by spring pressure, or by oil pressure overcoming the spring pressure. Hose (3) connects to the end of the selector valve assembly, and pressure works on the first piston, item No. 3. Hose (2) connects on top of the selector valve assembly, and pressure works on the second piston, item No. 6. Hose (1) connects on top of the selector valve assembly, and pressure works on the third piston, item No. 7. The range line connects to the end of the range selector valve assembly, and oil pressure works on the piston, item No. 61.

Figure 13 shows a cross section cutaway of the eight speed hydraulic shift

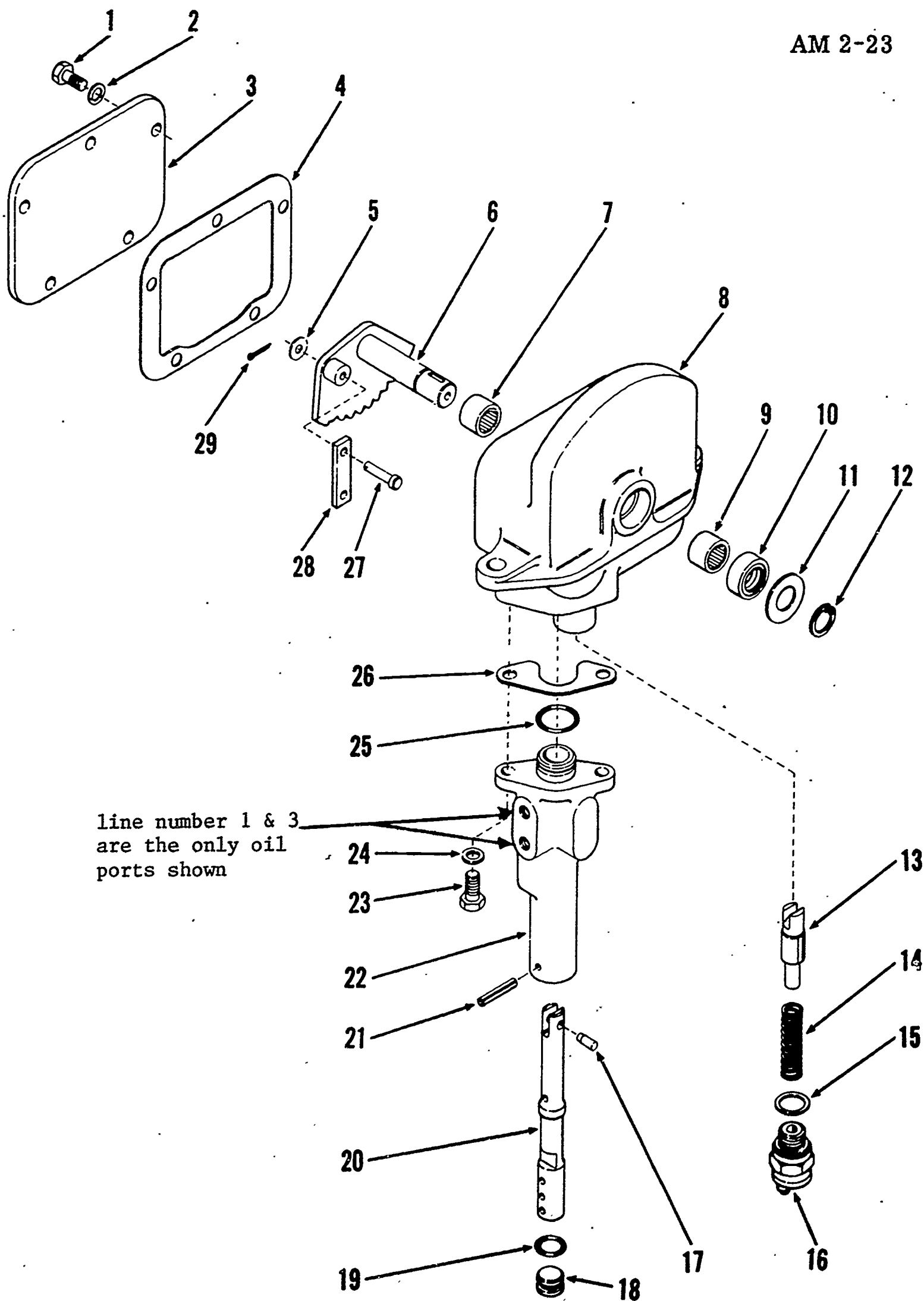

Fig. 11 Breakdown of the shift control valve

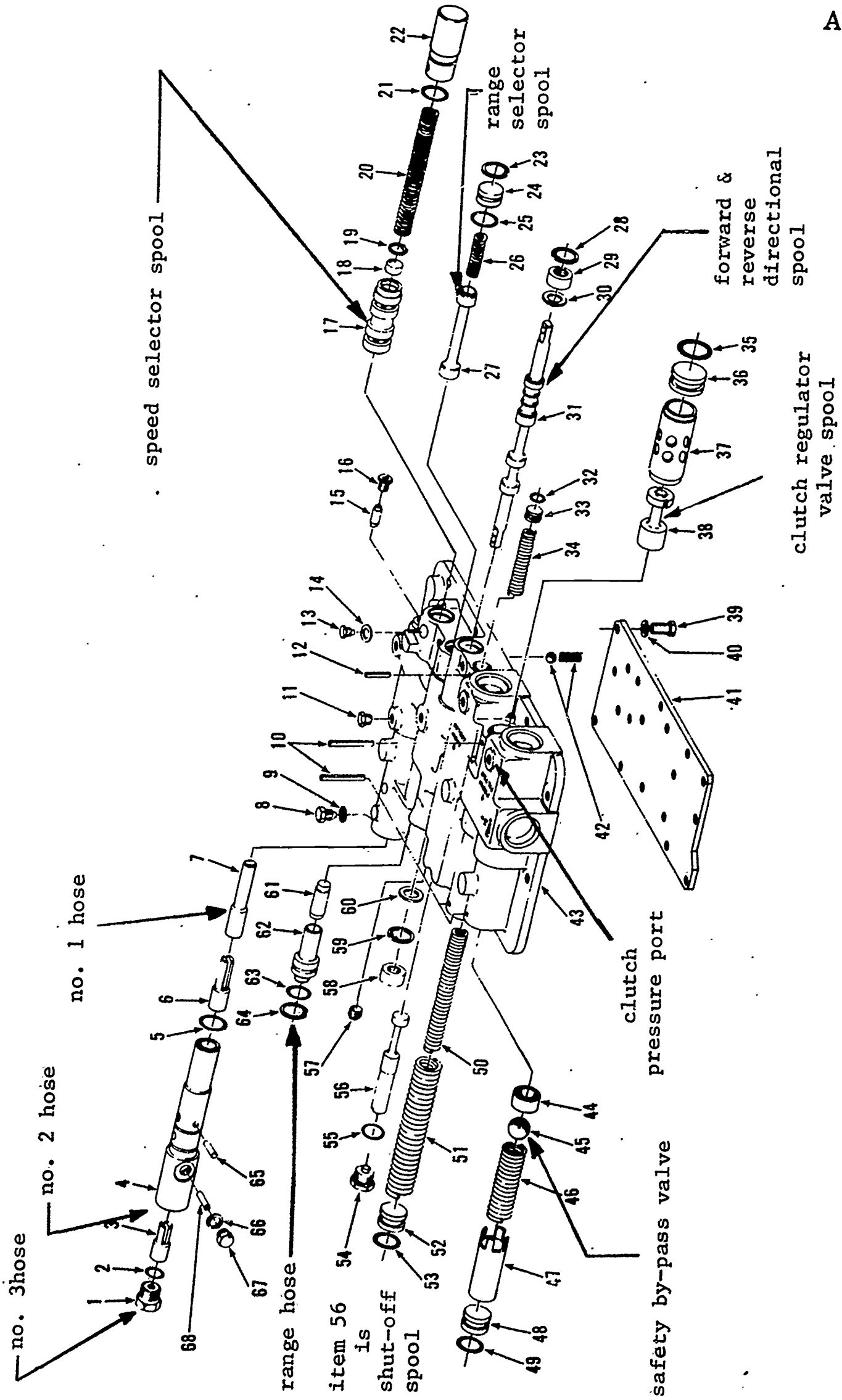

Fig. 12 Breakdown of the transmission control cover



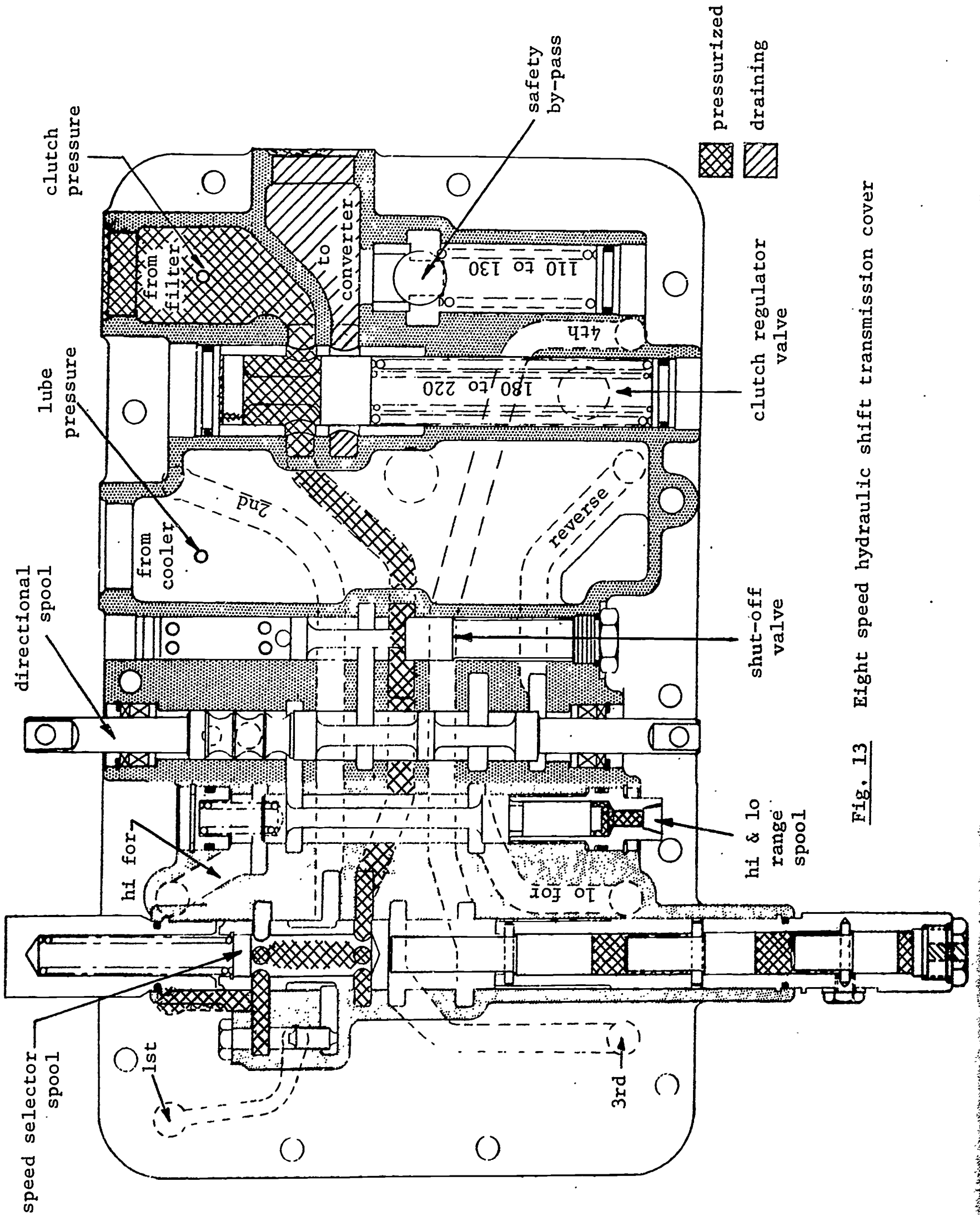

Fig. 13 Eight speed hydraulic shift transmission cover

transmission control cover. Oil pressure from the pump comes into the cover at a point marked "from filter" and passes along a main supply passage under the spools. The oil pressure comes up at the speed selector spool. The speed selector spool can be shifted to allow the oil pressure to go to one of the four speed clutches. Oil pressure also comes up around the declutch valve. If the declutch valve is open (it always will be on a dozer or scraper) the oil pressure can go to the directional spool. If the directional spool were shifted into forward position, the oil pressure could go to the range spool. If the directional spool were in neutral or reverse, the oil could go no further than the lands on the directional spool. Pressure goes into a drilled passage (leading from the main supply passage, to a passage leading up to the directional spool) on the opposite side of the declutch valve. If the directional spool is in reverse position, then oil pressure can go to reverse clutch. The only flow of oil in the control cover passages, around the spools and to the clutches, will be that which is necessary to fill a clutch and whatever leakage there is by the sealing rings in the transmission. The remainder of pump flow will go through the clutch pressure regulating valve and out a port marked CONVERTER.

Figure 14 shows the speed selector valve assembly in four different positions, and the range selector valve assembly in two positions.

Note that the oil pressure coming from the shift control valve does not go any further than the piston it works against. This oil pressure only overcomes the spring pressure to move the spools.

The pistons in the speed selector valve assembly are slotted and are limited in travel by stop pins.

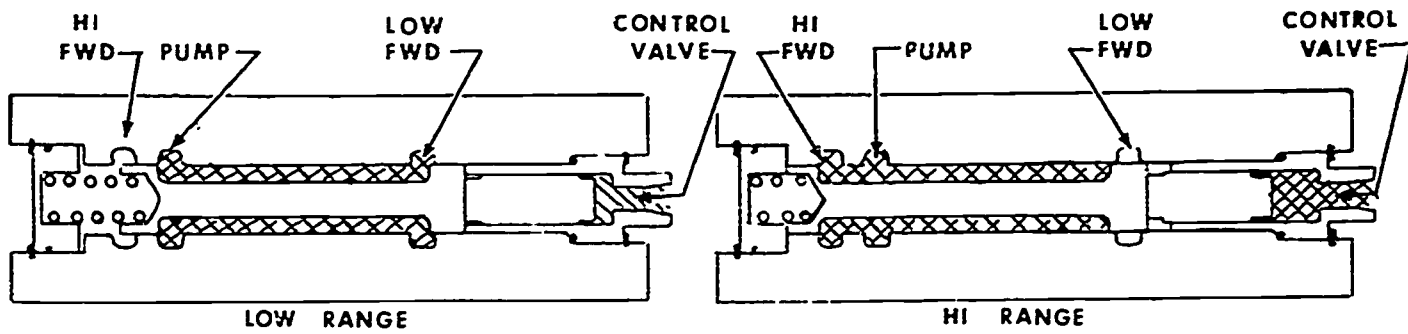

Range Plunger

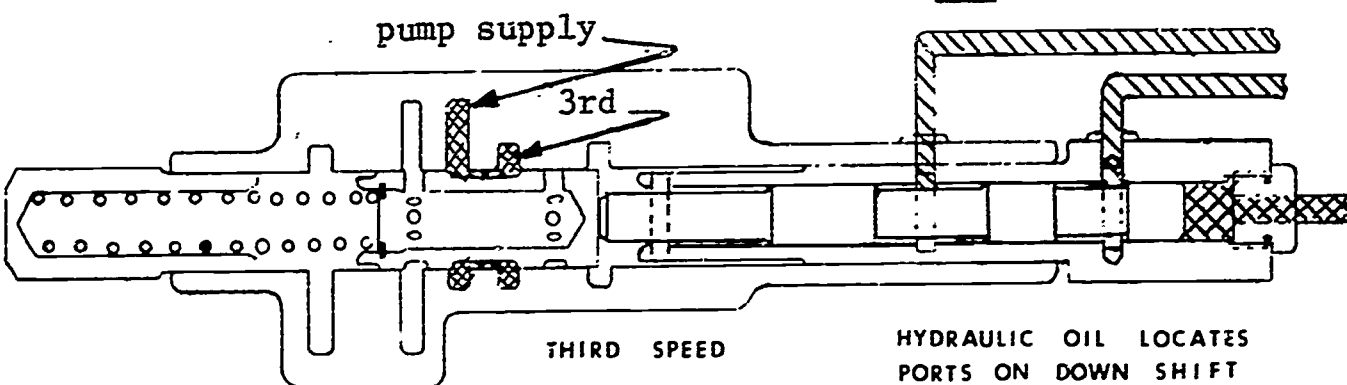
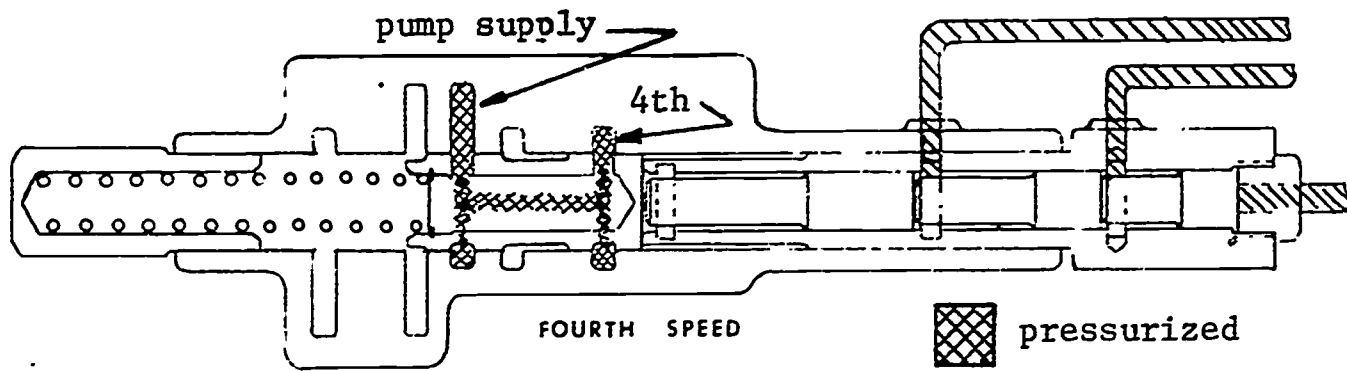

SPRING LOCATES PORTS ON UP SHIFT

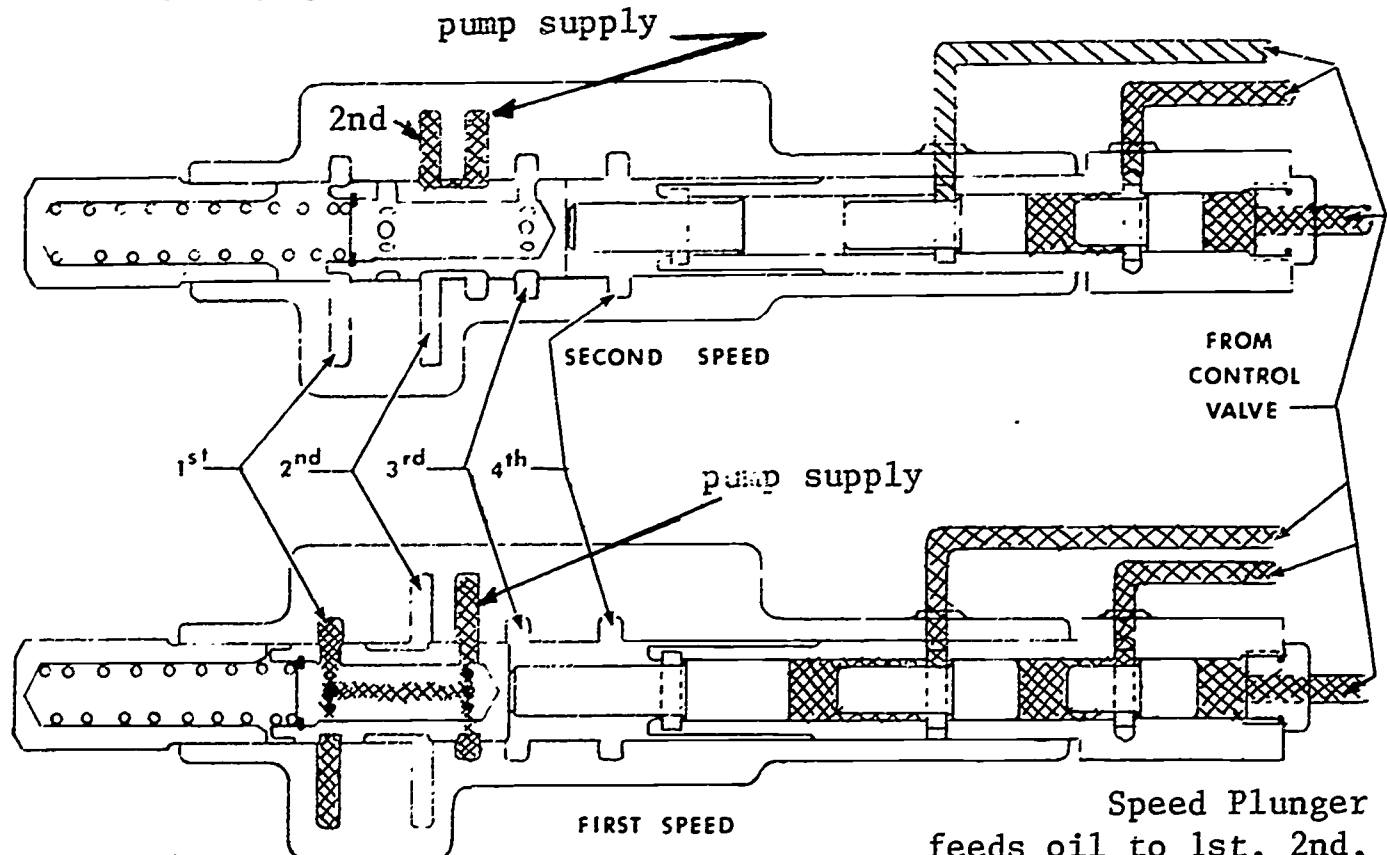

Speed Plunger feeds oil to 1st, 2nd, 3rd, & 4th

Fig. 14 Range valve and speed valve in different positions



DIDACTOR PLATES FOR AM 2-23 D AND AM 2-24 D

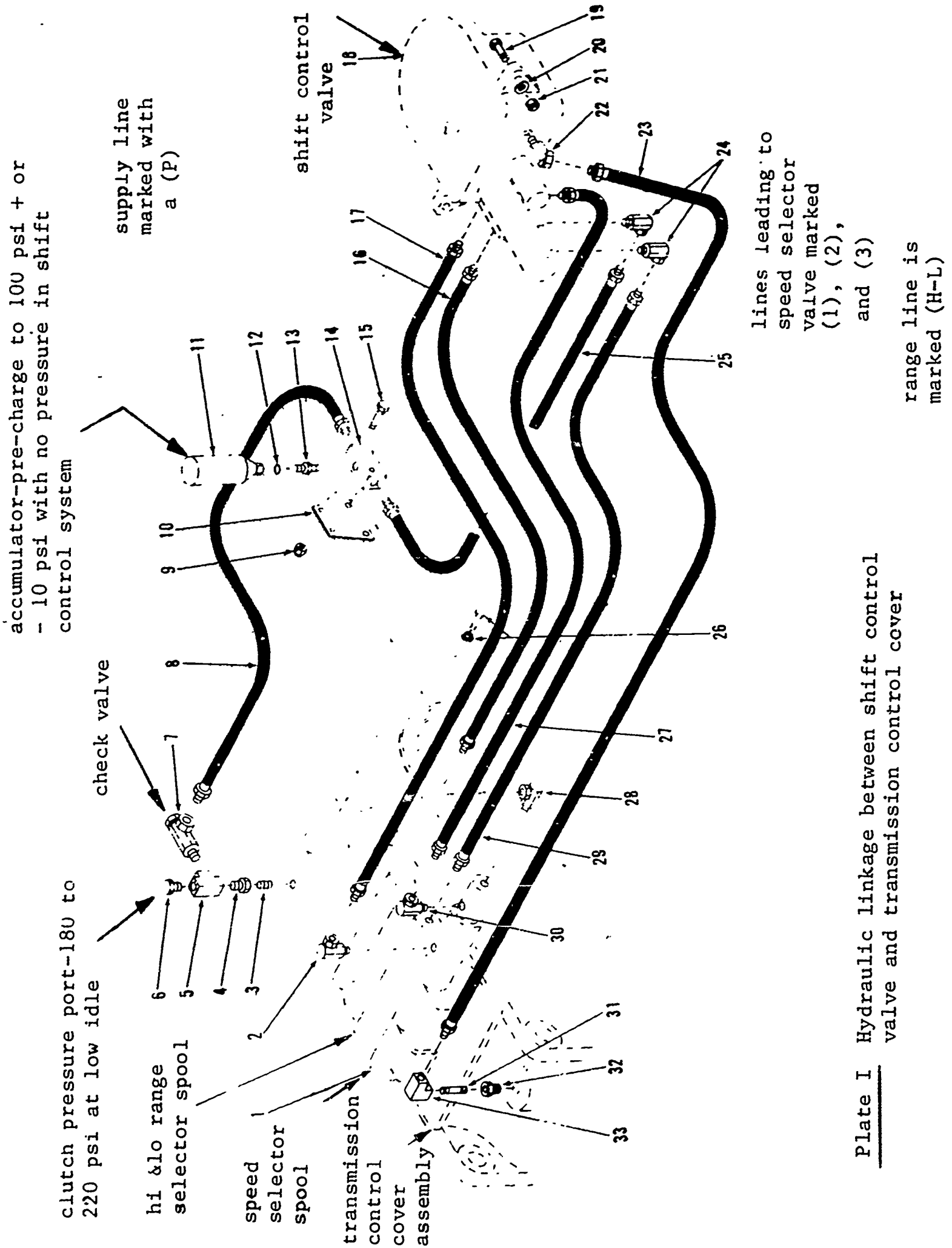

Plate I Hydraulic linkage between shift control valve and transmission control cover

AM 2-23 D
AM 2-24 D

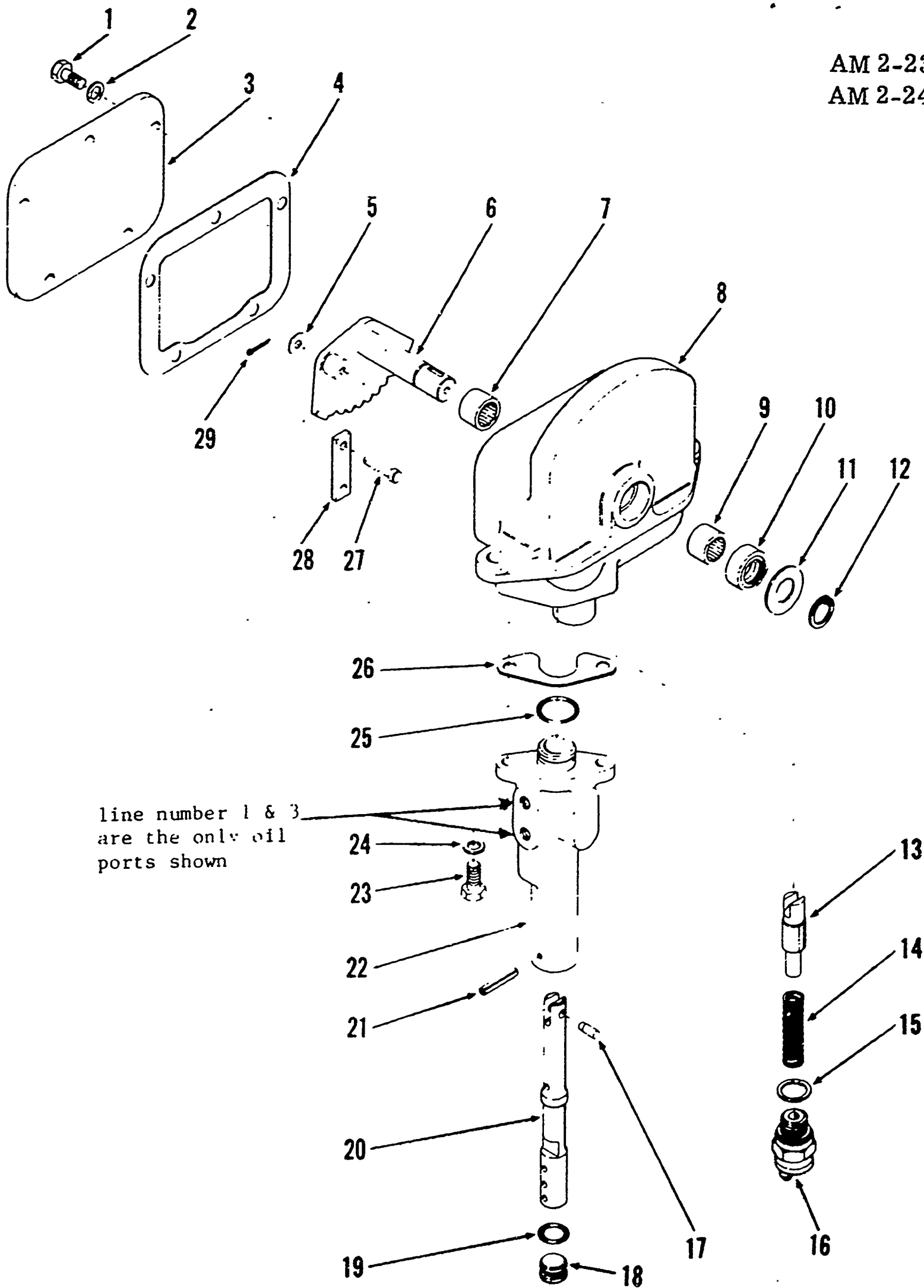

Plate II Shift control valve (exploded view)

HOSES THAT HAVE PRESSURE IN THEM

LEVER POSITION AND GEAR

1st	1, 2, 3
2nd	1, 2, 3 Range
3rd	2, 3
4th	2, 3 Range
5th	3
6th	3, Range
7th	None
8th	Range

Plate III

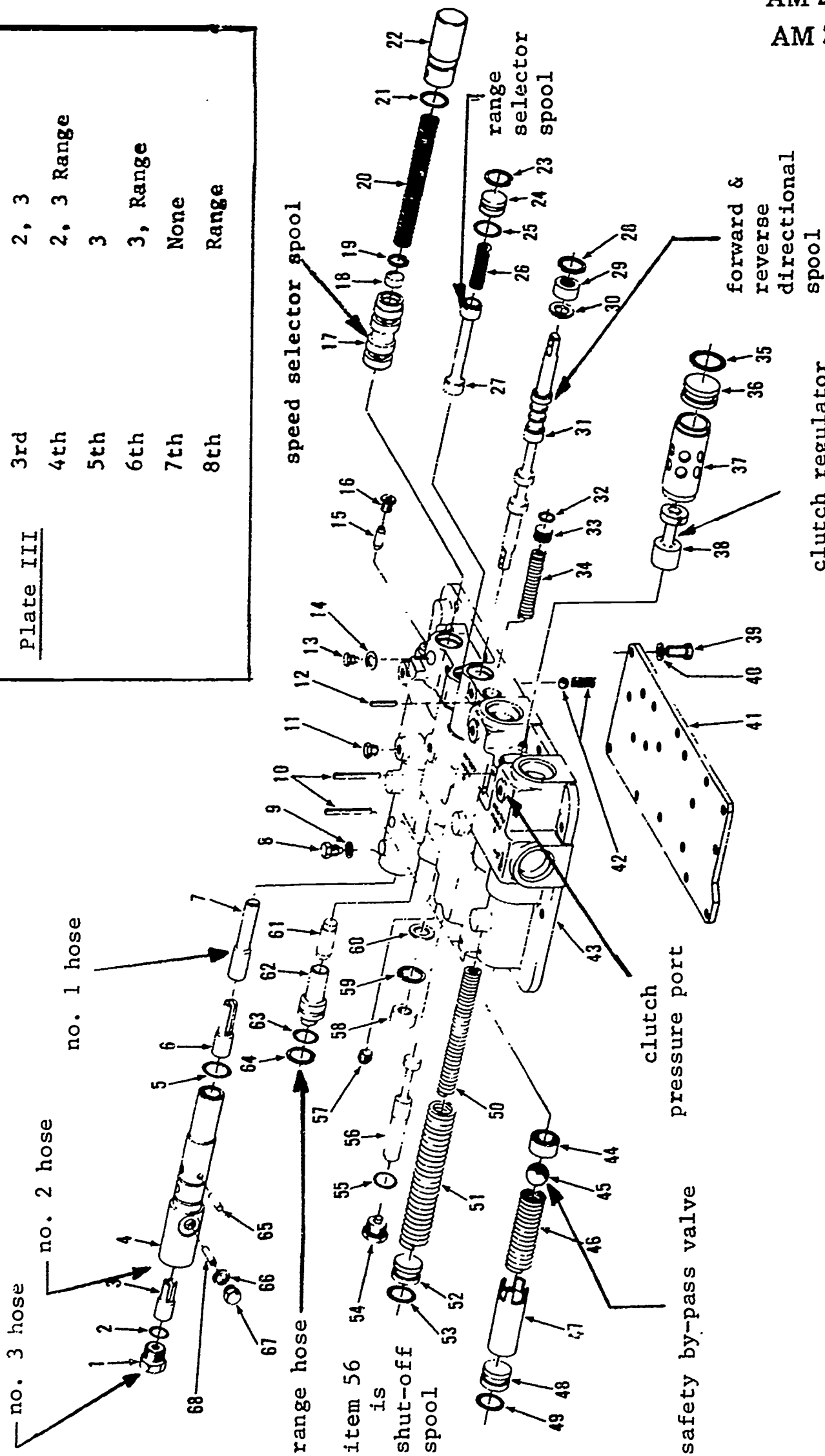

Plate IV Transmission control cover (exploded view)

AM 2-23D
AM 2-24D
10/25/67

MICHIGAN/CLARK TRANSMISSION --
MECHANICAL AND HYDRAULIC SHIFT
and
OIL FLOW THROUGH THE VALVES AND
CONTROL COVER ASSEMBLY

Human Engineering
Institute

Minn. State Dept. of Ed.
Vocational Education

Press A 1

Check to see that timer
and index are OFF

In this film we will discuss mechanical and hydraulic shifting in the Michigan/Clark transmission. We will give particular attention to oil flow in and between the shift control valve and the transmission control cover.

Let's begin with a brief discussion of the control levers in the operator's cab.

Press A 2

1-1

2

On the vehicle steering column there are two control levers -- the DIRECTIONAL SHIFT LEVER and the SPEED RANGE LEVER.

The upper lever is the directional shift lever. It has three positions -- forward, neutral and reverse.

Press A 3

1-2

3

Shifting the directional lever to its farthest position AWAY from the operator places the directional spool in the transmission control cover in the _____ position.

- A. forward 5
- B. neutral 4
- C. reverse 4

1-3

4

No.

The position farthest away from the operator is the FORWARD position. This is indicated by the symbol FWD on the shift quadrant.

Press A 5

1-4

5

OK. The forward position (FWD) is away from the operator.

The intermediate position is the neutral (NEU) position, and the position closest to the operator is reverse (REV).

The directional shift lever is the _____ lever on the steering column.

- A. lower 6
- B. upper 7

1-5

6

Incorrect.

The lower of the two control levers is the speed range lever. The directional shift lever is above the speed range lever.

Press A 7

1-6

7

OK.

The directional shift lever is connected to the directional spool in the transmission control cover by the forward-reverse control rods, a bellcrank assembly and an adjustable clevis.

Press A 8

1-7

DIDACTOR

AM 2-23D
AM 2-24D
10/25/67

2

8

The lower lever on the steering column is the speed range lever. It has eight separate positions, for the eight forward speeds. Each position is noted on the shift quadrant assembly, mounted to the side of the steering column.

Press A 9

1-8

9

The speed range lever is connected to the shift control valve (located under the floor board) by the speed range control rod and an adjustable clevis.

The function of the shift control valve is to properly place a combination of spools in the transmission control cover when different speeds are selected.

Press A 10

1-9

10

The linkage between the shift control valve and the transmission control cover is _____.

- A. hydraulic 12
- B. mechanical 11

1-10

11

No.

The shift control valve positions the valve spools **HYDRAULICALLY** in the transmission control cover. The spool positions correspond to the speed range selected by the operator.

Press A 13

1-11

12

OK. The valve spools are positioned hydraulically. They direct oil pressure from the supply pump to the appropriate clutch in the transmission, engaging it in the speed range selected by the operator.

For a quick review of this brief introduction, press A. 2

Press B if you prefer to go on. 14

X(C)-13

1-12

13

OK. The valve spools are positioned hydraulically. They direct oil pressure from the converter supply pump to the appropriate clutch in the transmission, engaging it in the speed range selected by the operator.

Since you have made an error on at least one question, let's have a quick review.

Press A 2

1-13

14

Through the use of a control valve, hoses and a steady pressure, the mechanical linkage can be eliminated when shifting portions of the transmission.

The pressure needed is obtained by tapping into a clutch pressure port. The shift control valve guides the pressure through various hoses to the transmission, to shift the range selector and speed selector spools.

Press A 15

2-14

15

Plate I shows the external hoses which connect the shift control valve to the transmission control cover.

Clutch oil pressure, tapped from the clutch pressure port in the transmission control cover, passes through a check valve (Plate I, item 7) and on to an accumulator (item 11).

Press A 16

2-15

16

The check valve prevents oil from flowing backwards into the _____.

- A. accumulator 17
- B. shift control valve 18
- C. clutch pressure port 19

2-16

17

You are incorrect. (See Plate I.)

Remember that we said that the pressure needed for hydraulic shifting comes from oil tapped through the clutch pressure port. The check valve is a one way valve which prevents the oil from flowing back into the clutch pressure port.

Press A 19

2-17

18

Incorrect. (See Plate I.)

The oil flow through the supply hoses (items 8 and 25) is TOWARD the shift control valve.

The check valve (item 7) is a one way valve which permits oil to flow toward the accumulator and the shift control valve, but prevents oil from flowing back into the clutch pressure port.

Press A 19

2-18

19

OK.

Clutch supply pressure drops slightly when a shift is made from one speed range to another. To assure smooth, quick shifts from one gear to the next, an accumulator is inserted in the supply line between the transmission control cover and the shift control valve.

Press A 20

2-19

20

The accumulator stores a supply of oil under pressure, so that the shift control system has a constant supply of oil.

When there is no pressure in the shift control system, the precharge pressure in the accumulator should be _____ psi.

- A. 180 to 220 21
- B. 90 to 110 23
- C. 110 to 130 22

2-20

21

No.

The normal pressure at the clutch pressure port (at low idle) is 180 to 220 psi.

The precharge pressure in the accumulator should be between 90 and 110 psi with no pressure in the shift control system.

Press A 23

2-21

22

No.

The setting 110 to 130 psi is for the converter safety valve, which we discussed in another film.

The precharge pressure in the accumulator should be between 90 and 110 psi with no pressure in the shift control system.

Press A 23

2-22

23

OK. Specifications call for 100 psi +10 psi as the precharge pressure on the accumulator (with no pressure in the shift control system).

* * * *

Oil can flow from the shift control valve to the speed selector valve (in the transmission control cover) through any of three hoses.

Press A 24

2-23

4

24

See Plate I.

Item 17, leading from the shift control valve to the speed selector valve in the transmission control cover, is hose one. Hose one is connected to the speed selector valve through a coupling, item 2.

Press A 25

2-24

25

Hose two is item 27 in Plate I. It connects to the speed selector valve through a separate coupling, item 30.

Hose three is item 16; it connects to the speed selector valve through a third coupling, item 28.

The connecting points for these three hoses are marked (1), (2), (3) on both the shift control valve and the speed selector valve.

Press A 26

2-25

26

Only one hose connects the shift control valve to the HI-LO range control valve (in the transmission control cover). The range hose, as it is known, is item 29 in Plate I. At the shift control valve, the connecting point for the range hose is marked (H-L). There is no marking at the range control valve connecting point.

Press A 27

2-26

27

How many hoses are needed to connect the shift control valve to the speed selector valve in the transmission control cover?

- A. Only one 28
- B. Two 28
- C. Three 30
- D. I'm not sure. 29

2-27

28

No.

THREE hoses -- hose ONE, hose TWO and hose THREE -- connect the shift control valve and the speed selector valve.

A single hose connects the shift control valve to the range control valve.

Press A 30

2-28

29

Perhaps you missed the information that would help you answer the last question.

Let's have a quick review of our discussion of the hoses. Then you can try the question again.

Press A 23

2-29

30

OK. Hoses one, two and three connect the shift control valve to the speed selector valve. The range hose connects the shift control valve to the HI-LO range selector valve.

If you would like a quick review of this section, press A. 14

Otherwise, press B. 32

X(C)-31

2-30

31

OK. Hoses one, two and three connect the shift control valve to the speed selector valve. The range hose connects the shift control valve to the HI-LO range selector valve.

Since you have had some trouble with at least one question, let's have a quick review.

Press A 14

2-31

5

32

Let's take a closer look at the shift control valve.

Plate II shows an exploded view of this valve.

Which control lever on the vehicle steering column is connected to the cam (item 6)?

- A. The directional shift lever 33
- B. The speed range lever 34

3-32

33

No.

The cam has eight detents, one for each of the eight speed positions. The cam is connected mechanically to the speed range lever on the steering column.

Press A 34

3-33

34

OK.

The detent stop (Plate II, items 13 and 14) holds the speed selector cam in place as the transmission is shifted into the various speed ranges.

Item 16 is a microswitch, which holds the detent spring in position. This switch is used for vehicles with converter lock-up.

Press A 35

3-34

35

On a vehicle with converter lock-up, the micro-switch in the shift control valve _____

- A. helps make it easier to shift the transmission 36
- B. prevents the operator from shifting the transmission 37

3-35

36

No.

The function of the microswitch is to PREVENT the transmission from being shifted during converter lock-up.

Press A 37

3-36

37

OK.

See Plate II. Item 22 is the spool housing. Proper spacing between the spool housing and the control valve main housing is very important. Shims (item 26) are used to provide proper spacing and to assure sufficient spool sealing.

Press A 38

3-37

38

During reassembly of the shift control valve, it is important to replace exactly the same number of shims as were removed during disassembly.

To test for the installation of the proper number of shims, place the shift control valve in eighth gear position. Look into the supply hole. The spool land should cover one-half of the hole.

Press A 39

3-38

39

If too many shims have been installed between the spool housing and the main housing of the shift control valve, the spool land will cover _____ one-half of the supply hole, with the valve in eighth gear position.

- A. less than 41
- B. more than 40

3-39

6

40

You are incorrect.

With the shift control valve in eighth gear position, the spool land is in its farthest position downward.

Too many shims will place the spool housing in a position lower than needed. With the supply hole in a lower than normal position, LESS than one-half of the spool land will be visible.

Press A 41

3-40

41

OK. With too many shims installed, less than one-half of the spool land will be visible (or it may not be visible at all, depending on how many shims were added).

With too few shims installed, more than one-half of the spool land will be visible, of course.

Press A 42

3-41

42

The two holes noted on the side of the spool housing (Plate II, item 22) are the connecting holes for hoses one and three. The holes for hose two and the range hose are not visible in this view.

When any of the four hoses is pressurized, does the oil flowing in it flow directly to the clutch packs?

- A. Yes 43
- B. No 45
- C. I'm not sure 44

3-42

43

You are incorrect.

Oil in the shift control system hoses does NOT go directly to a clutch to engage it. When a hose is pressurized, it directs oil to the appropriate valve in the transmission control cover. The spool of that valve is then positioned to direct oil to the appropriate clutch.

Press A 45

3-43

44

Oil in the shift control system hoses (one, two, three and range) does NOT flow directly to the clutch packs. When one of these hoses is pressurized, it directs oil into the appropriate valve in the transmission control cover assembly. The spool in the valve then is positioned so that oil is directed from the supply pump to the appropriate clutch.

Press A 42

3-44

44

OK. Press B if you would like a brief explanation of the correct answer to the preceding question.

* * * * *

Varying combinations of the hoses between the shift control valve and the transmission control cover assembly are pressurized to obtain the different speed ranges. Any hose which is not pressurized will drain through the shift control valve main housing, out through the drain hose (Plate I, item 23), back to the transmission sump.

Press A 46

3-45

45

46

See Plate III. This is a chart which shows the combinations of pressurized hoses for the various gear positions.

In which gear position are all of the hoses draining simultaneously?

- A. Second 48
- B. Seventh 49

X(C)-47

3-46

47

OK. When a hose is pressurized, oil flows in it to the appropriate valve in the transmission control cover. Any hose which is not pressurized drains through the shift control valve main housing and a drain hose, back to the transmission sump.

Before we continue, let's have a quick review of the shift control valve, since you have made an error or two on the questions.

Press A 32

3-47

48

Your answer is incorrect. (See Plate III.)

Notice that in second gear position, all four hoses have pressure in them. Note that second gear is the only case where this is true.

In SEVENTH gear position, NONE of the hoses have pressure in them. This means that they are all draining simultaneously in seventh gear.

Press A 49

3-48

49

OK. All four hoses drain simultaneously in seventh gear position.

If only hose one and the range hose are draining, the speed selector lever is in _____ gear position.

- A. third 52
- B. fourth 50
- C. fifth 51

3-49

50

You are incorrect. (See Plate III.)

Note that in fourth gear position, hoses two and three and the range hose have pressure in them. This means that in fourth gear, only hose one is draining.

Look over Plate III carefully. In which gear are hose one and the range hose the only ones draining? Try the question again.

Press A 49

3-50

51

No. (See Plate III.)

In fifth gear position, hose three is the only one with pressure in it. This means that hoses one and two and the range hose are draining.

In THIRD gear position, however, only hoses two and three have pressure in them. This means that in third gear position, the range hose and hose one are draining.

Press A 52

3-51

52

OK.

In which gear position is the range hose the only one that drains?

- A. Eighth 53
- B. Fifth 54
- C. Third 54
- D. First 55

3-52

53

No. (See Plate III.)

In eighth gear position the range hose is the only one that is PRESSURIZED.

Which gear position has all hoses EXCEPT the range hose pressurized?

Try the question again.

Press A 52

3-53

54

You are incorrect. (See Plate III.)

In third gear position, both the range hose and hose one are draining; in fifth, all hoses are draining except hose three. In eighth gear position, the range hose is the only one that is pressurized.

Note that in FIRST gear position, however, all hoses are pressurized EXCEPT the range hose. It is the only one that drains in first gear.

Press A 55

3-54

55

OK.

The oil that is relieved (drained) from the various hoses in the various speed ranges normally flows _____.

- A. back to the accumulator 56
- B. to a drain hose and then back to the transmission sump 58
- C. directly to the clutch packs to activate them 57

3-55

56

No.

Oil would drain back toward the accumulator only if accumulator internal pressure were depleted and pressure in the supply hose were extremely low. This would occur only if there were a malfunction.

Try the question again.

Press A 55

3-56

57

No. Remember that oil in the lines between the shift control valve and the transmission control cover does not flow directly to the clutch packs. This is true even when the lines are draining.

Oil that is relieved from the hoses flows through the shift control valve main housing to a drain hose and back to the transmission sump. Only after leaving the sump could the oil find its way to the clutch packs.

Press A 59

3-57

58

OK.

Before we take a closer look at the transmission control cover, you may want to review.

If you want a review which includes our discussion of the shift control valve, press A. 32

Press B if you want a review of only the portion on pressure and drainage in the hoses. Press E if you prefer to go on.

X(C)-59

4-58

59

OK. Oil that is relieved (drained) from the hoses eventually finds its way back to the transmission sump.

Since you have had a little trouble with the questions in this section, let's quickly review pressure and drainage in the hoses.

Press A 46

3-59

60

Let's take a closer look at the transmission control cover now.

Plate IV shows an exploded view of the control cover. The function of this control cover is the same as for the manual shift control cover -- to control the engagement and disengagement of the clutches.

Press A 61

4-60

61

When the transmission is shifted manually, the speed selector spool and the range selector spool are moved by _____ (1) _____. When shifting is hydraulic, the spools are moved by _____ (2) _____.

- A. (1) oil pressure overcoming spring pressure 62
- (2) spring pressure
- B. (1) spring pressure 63
- (2) oil pressure overcoming spring pressure

4-61

62

You have the correct answers reversed.

Action through the manual shift control cover causes the speed and range selector spools to be moved by mechanical spring pressure.

Through the hydraulic shift control cover, the spools are moved by oil pressure, acting against a piston to overcome spring pressure.

Press A 63

4-62

63

OK. The way the spools are moved is the only functional difference between the manual and hydraulic control covers.

See Plate IV.

Leading from the shift control valve, which we discussed previously, hose three is connected to the end of the speed selector valve assembly. Pressure from hose three works on the first piston in the selector valve (Plate IV, item 3).

Press A 64

4-63

9

64

Pressure from hose two enters at the top of the speed selector valve and works against the second piston (Plate IV, item 6).

Hose one also is connected to the top of the speed selector valve; pressure from hose one acts against the third piston (item 7).

The range hose is connected to the range selector valve and pressure acts against a piston (item 61).

Press A 65

4-64

65

Oil pressure comes from the supply pump into the transmission control cover assembly at a point marked "From Filter". The oil flows through a main supply passage under the spools.

From the main supply passage, oil comes up _____

- A. at the speed selector spool 66
- B. around the declutch valve 67
- C. at both of the above locations 68

4-65

66

You are only partly correct.

Oil comes up from the main supply passage at both points -- at the speed selector spool and around the declutch valve.

Oil flowing through the speed selector spool is directed to the appropriate speed clutch. Oil flowing around the declutch valve is directed to the directional spool, and also to the range spool if necessary.

Press A 68

4-66

67

You are only partly correct.

Oil comes up from the main supply passage at both points -- around the declutch valve and at the speed selector spool.

Oil flowing around the declutch valve is directed to the directional spool, and then to the range spool if necessary. Oil flowing through the speed selector spool is directed to the appropriate speed clutch.

Press A 68

4-67

68

OK.

Oil pressure (from hoses one, two and three) positions the speed selector spool so that oil will be directed to the appropriate speed clutch, depending on the gear selected.

With pressure in hoses two and three, for example, oil is directed to the **SECOND** speed clutch.

Press A 69

4-68

69

If the declutch valve is open, oil can also flow from the supply passage to the directional spool.

What happens next depends on the position of the directional shift lever on the steering column.

If the operator has selected neutral or reverse, the oil can flow _____

- A. on to the range spool 70
- B. only as far as the directional spool lands 71

X(C)-69.1

4-69

69.1

Before we continue our discussion of oil flow through the transmission control cover, let's have a quick review.

Take your time in answering the questions.

Press A 69

4-69.1

70

You are incorrect.

With the declutch valve open and the directional lever in neutral or reverse, the oil can flow only as far as the lands of the directional spool.

There is no need for oil to flow to the range spool under these conditions. Pressure in the range spool is needed only to activate either the HI or LO **FORWARD** clutch.

Press A 71

4-70

10

71

OK. Oil can flow to the range spool only when the directional spool is in the FORWARD position.

SEE Plate III.

In the forward gears in which the range hose is PRESSURIZED, the range spool directs pressure to the _____ clutch.

- A. HI forward 73
- B. LO forward 72

4-71

72

No. (See Plate III)

Note that the range hose is pressurized in second, fourth, sixth and eighth gears. In the film on transmission and converter function we included a chart which showed that the HI forward clutch is engaged in each of the even-numbered forward gears.

Press A 73

4-72

73

OK. In all the even-numbered forward gears (2nd, 4th, 6th and 8th), the range hose is pressurized and the HI forward clutch is engaged.

How far does oil flow in the transmission control cover when the operator shifts into an ODD-numbered forward gear?

- A. All the way to the range spool 75
- B. Only as far as the directional spool 74

4-73

74

Incorrect.

Oil flow goes as far as the directional spool only when the operator shifts into neutral or reverse.

Oil flows all the way to the range spool any time a FORWARD gear is chosen.

Press A 75

4-74

75

OK. Oil flows to the range spool in all forward gears.

The difference is this:

When an odd-numbered forward gear is selected, the range hose drains. The range spool is positioned to send oil to the LO forward clutch.

In the even-numbered forward gears, the range hose is pressurized. This causes the range spool to send oil to the HI forward clutch.

Press A 76

4-75

76

In the odd-numbered forward gears, the range hose is _____ (1) _____ and the _____ (2) _____ clutch is engaged. In the even-numbered forward gears, the range hose is _____ (3) _____ and the _____ (4) _____ clutch is engaged.

- 77 A. (1) pressurized (2) LO forward (3) draining (4) HI forward
- 79 B. (1) draining (2) LO forward (3) pressurized (4) HI forward
- 78 C. (1) pressurized (2) HI forward (3) draining (4) LO forward
- 77 D. (1) draining (2) HI forward (3) pressurized (4) LO forward

4-76

77

You are incorrect.

You may be a little confused about which range clutch is engaged when the range hose is pressurized, and which one is engaged when it drains.

When the range hose DRAINS, the LO forward clutch is engaged. When the range hose is PRESSURIZED, the HI forward clutch is engaged.

Now, which of the two clutches is engaged in the ODD-numbered gears? Which in the EVEN-numbered gears?

Press A 75

4-77

78

Incorrect.

You have the right idea about the range hose and the clutches -- when the range hose is pressurized the HI forward clutch is engaged; when the range hose drains, the LO forward clutch is engaged.

But you have put these combinations together with the wrong groups of gears. Which of the two clutches is engaged in the odd-numbered gears? Which in the even-numbered gears?

Press A 75

4-78

Very good; you are correct. 79

FORWARD GEARS	CLUTCH ENGAGED	RANGE ROSE
ODF-numbered	LO forward	Draining
EVEN-numbered	HI forward	Pressurized

This chart shows the relationship between the selected forward gear, the range clutch and the range hose. Press A 80

4-79

If the directional spool is in the REVERSE position, then oil can flow to the reverse clutch. 80

We said earlier that oil can flow only to the directional spool while the vehicle is in neutral or reverse.

Oil can enter the directional spool cylinder on either of two sides. On one side of the directional spool, oil can enter from the declutch valve.

Press A 81

4-80

Oil can enter on the OPPOSITE side of the directional spool when reverse is selected. 81

When reverse is selected, oil flows through a branch passage (off the main supply passage) to the directional spool. This positions the spool so that it can direct oil to the reverse clutch.

Press A 82

4-81

The volume of oil flow through the transmission control cover assembly -- through the various passages, around the spools and to the clutches -- is relatively small. The volume will be no more than the amount it takes to fill the clutches plus the amount that leaks by the sealing rings in the transmission. 82

How many clutches must be filled before the vehicle will move?

- A. Only one 83
- B. Two 84
- C. Three 83

4-82

No. 83

TWO clutches must be engaged before the vehicle will move.

One of these clutches always will be one of the four speed clutches. The other always will be one of the three direction clutches -- LO forward, HI forward, or Reverse.

Press A 84

4-83

OK. It takes two engaged clutches to move the vehicle -- one speed clutch and one direction clutch. 84

There are seven clutches in the Michigan/Clark Power Shift Transmission. (1) _____ of them are speed clutches: (2) _____ of them are direction clutches.

- A. (1) Three (2) four 85
- B. (1) Four (2) three 86

4-84

No. 85

There are FOUR speed clutches in the Michigan/Clark transmission -- first, second, third and fourth.

There are THREE direction clutches -- LO forward, HI forward and Reverse.

Press A 86

4-85

OK. 86

You have completed this section on oil flow through the transmission control cover without an error. Very good!

If you would like to review this section, press A. 80

Press B 88 if you want to review only the portion on the directional spool.

Press D if you do not want to review. 88

X(C)-87

4-86

12

87

OK. Two clutches must be engaged to move the vehicle.

You have had some trouble with a question or two in this section, so we will have a brief review.

If you would like to review the complete discussion of oil flow through the transmission control cover, press A. *60*

Press B if you want to review only the portion on the directional spool. *68*

4-87

88

You have successfully completed this film.

Congratulations!

We hope that this film lesson has helped you to understand what happens in the Michigan/Clark transmission as the selector levers are operated.

Press REWIND

4-88

100-2-23 (17)

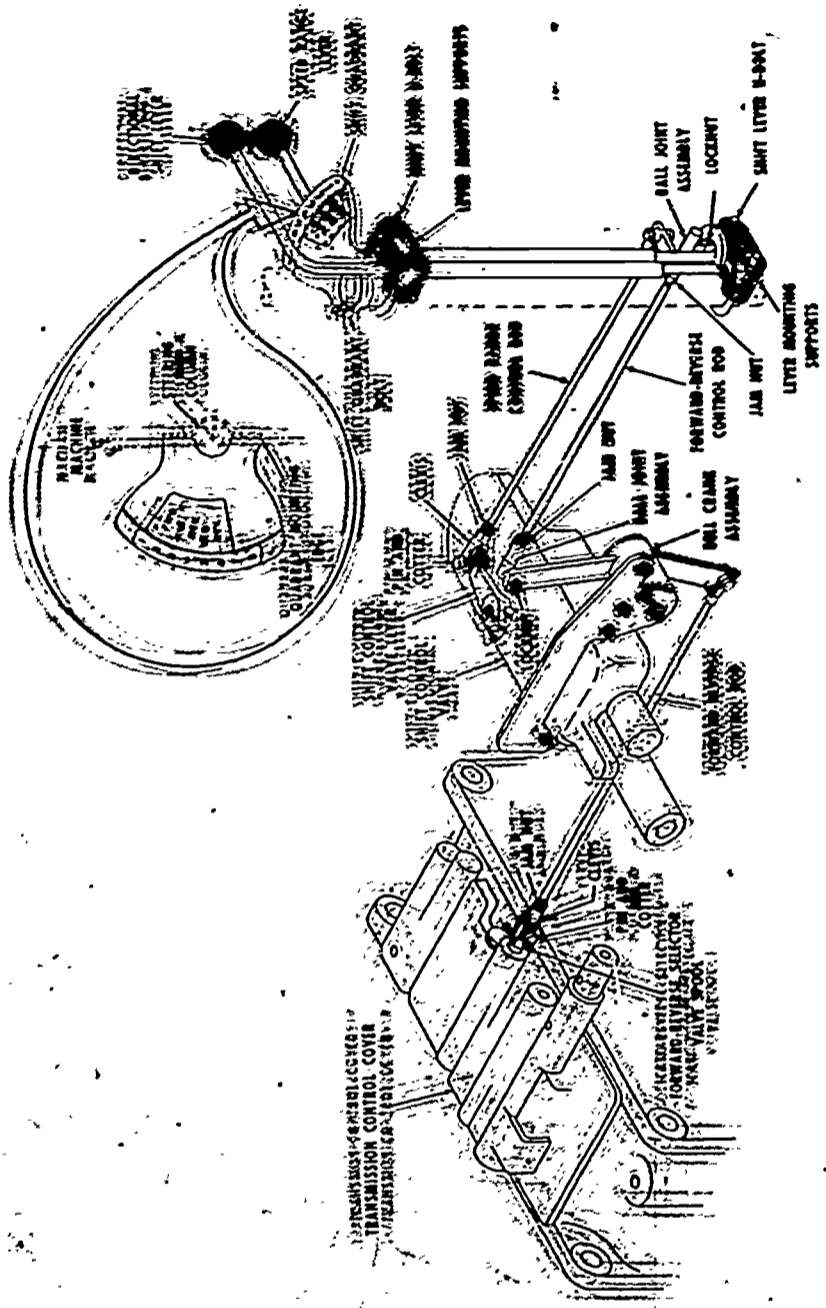

Mechanical and hydraulic linkage

HUMAN
ENGINEERING
INSTITUTE
2341 Carnegie Ave
Cleveland, Ohio 44115



(R)

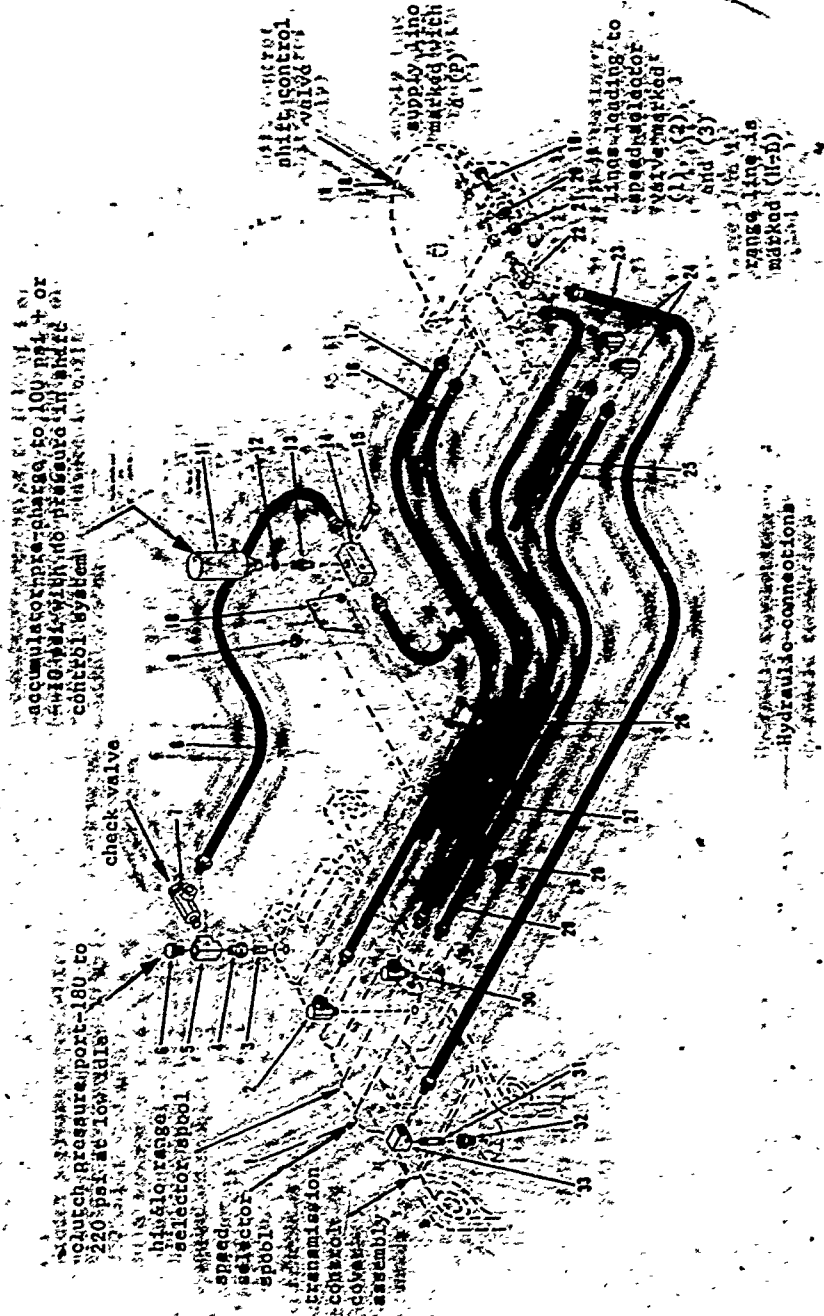

③
11/23/54

shift control valve shown in 1st gear
the directional spool can be in either
forward or reverse direction

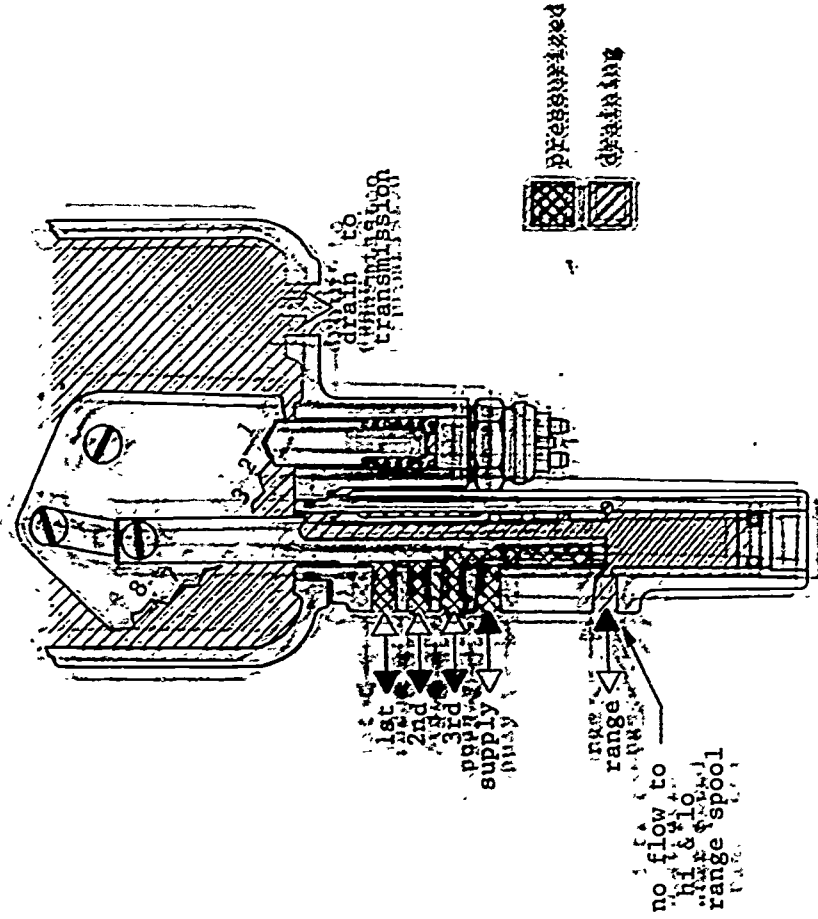

CONTROL VALVE



44-2323

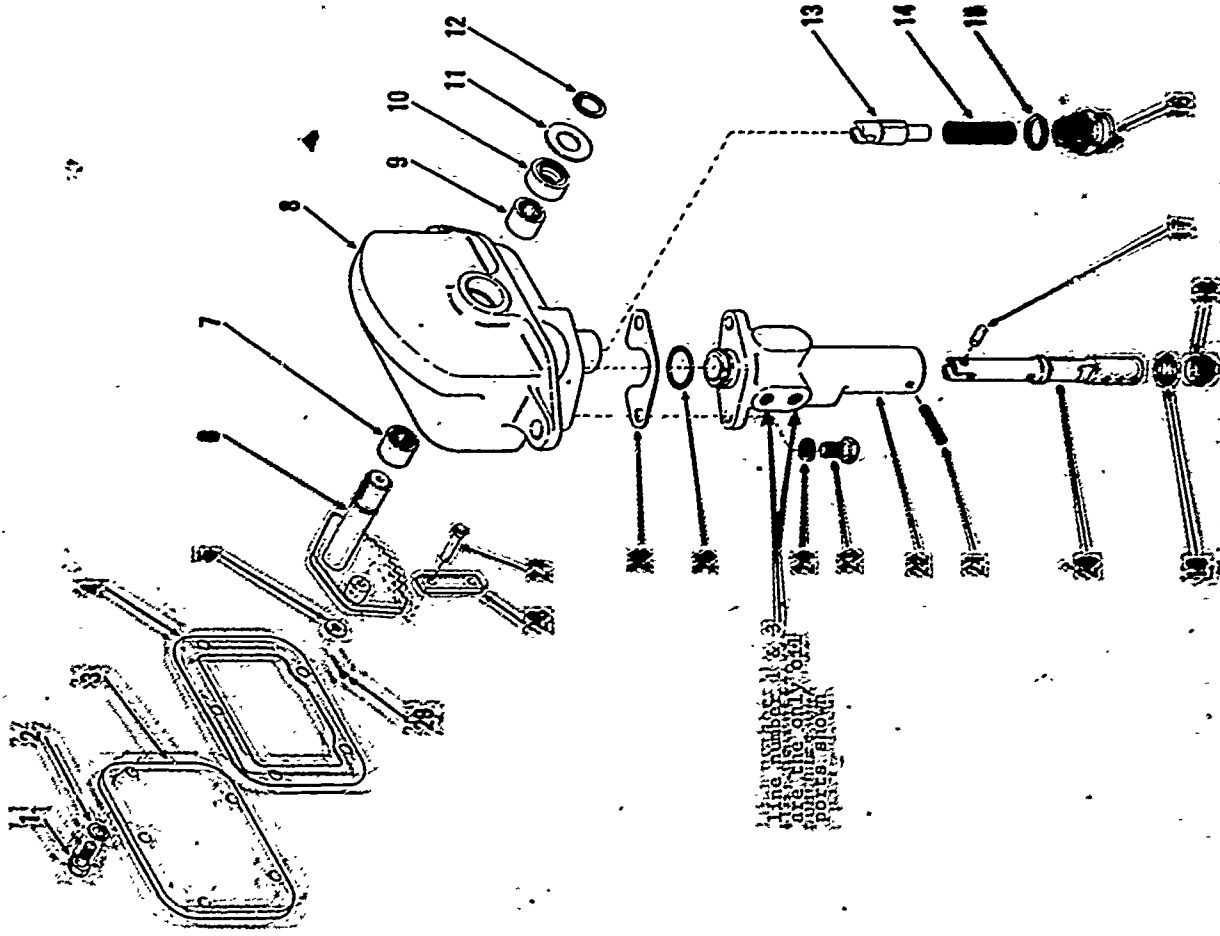

The number in the
circle is the
number of the
part, although
it may be
omitted.

REPAIRMAN'S SHIP-STEER CONTROL VALVE

AM2:23 (5)

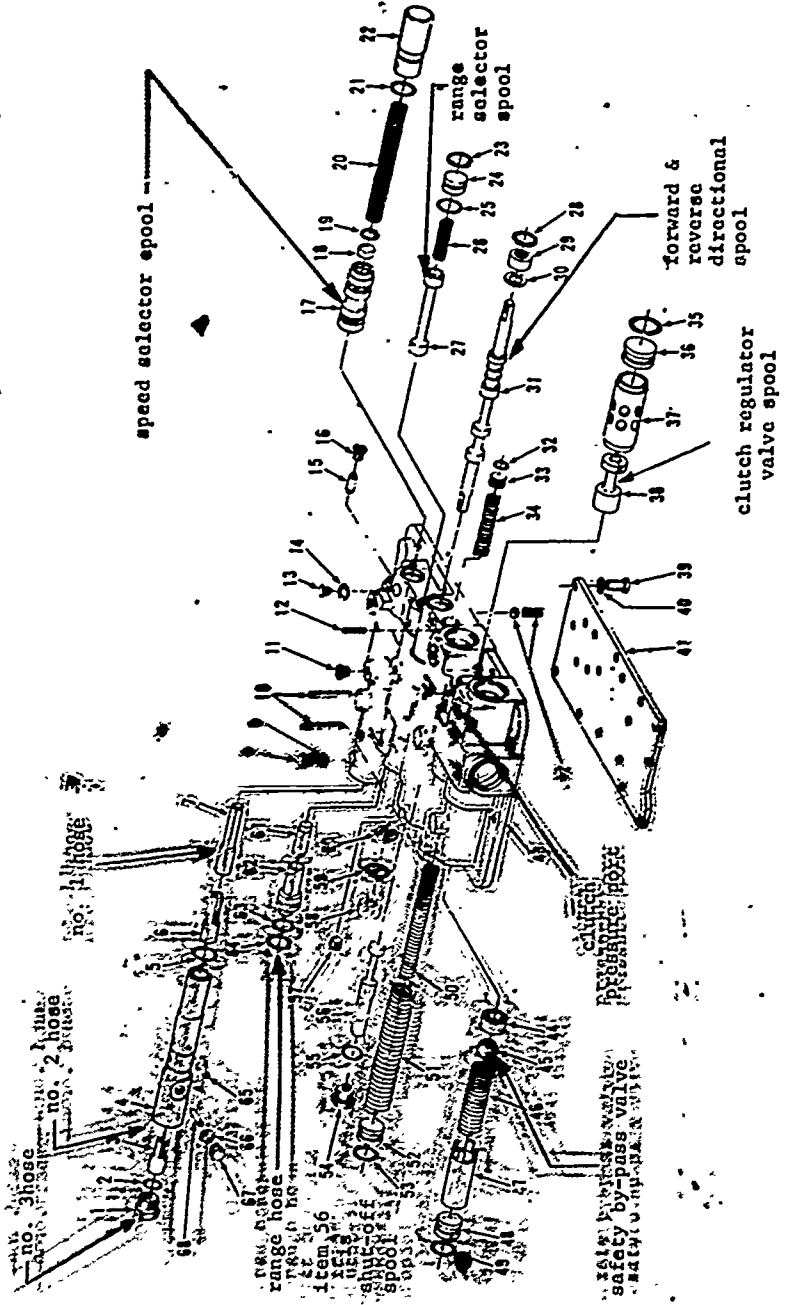

exploded view of the transmission control cover

AM 2-28

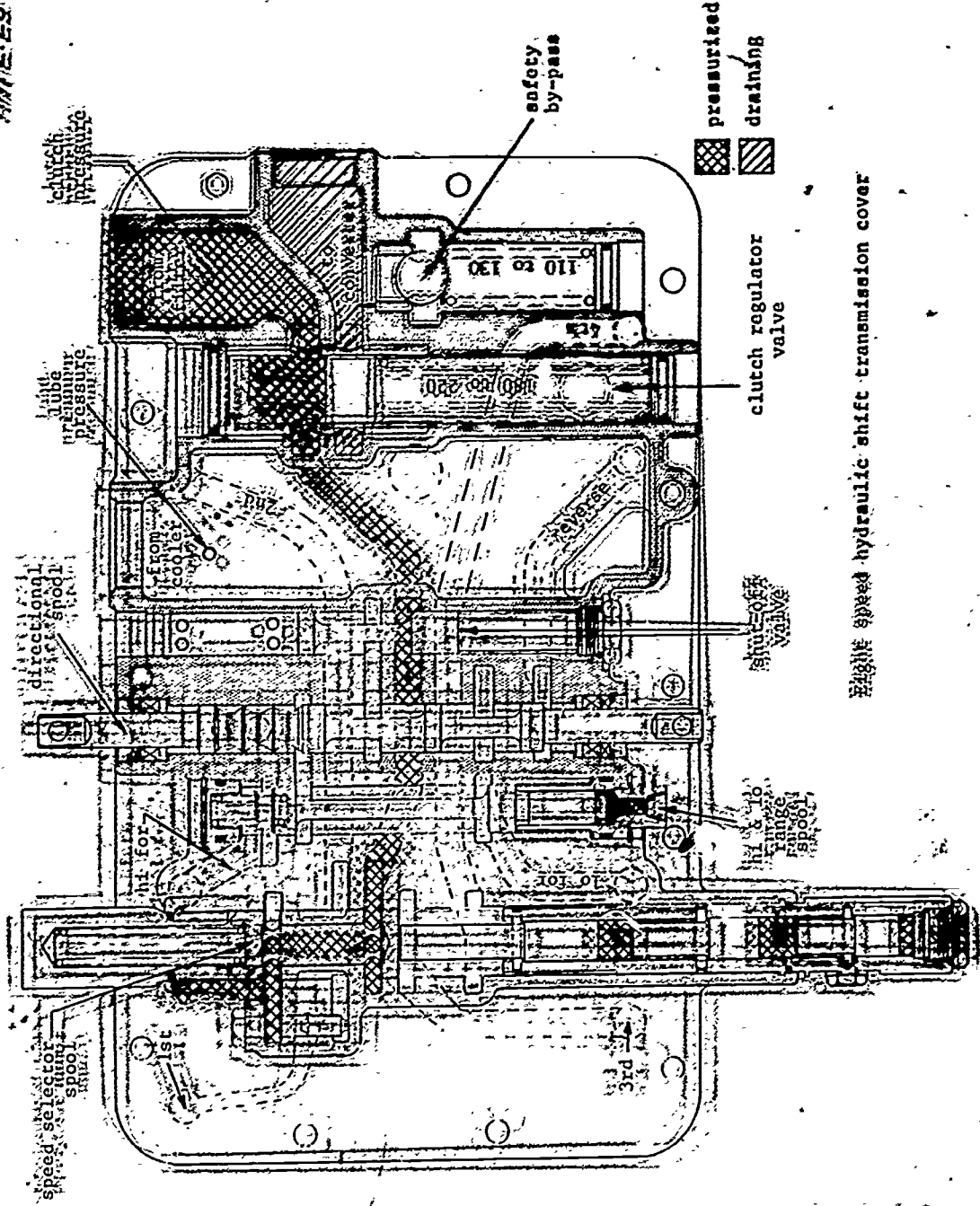

AM 23 27

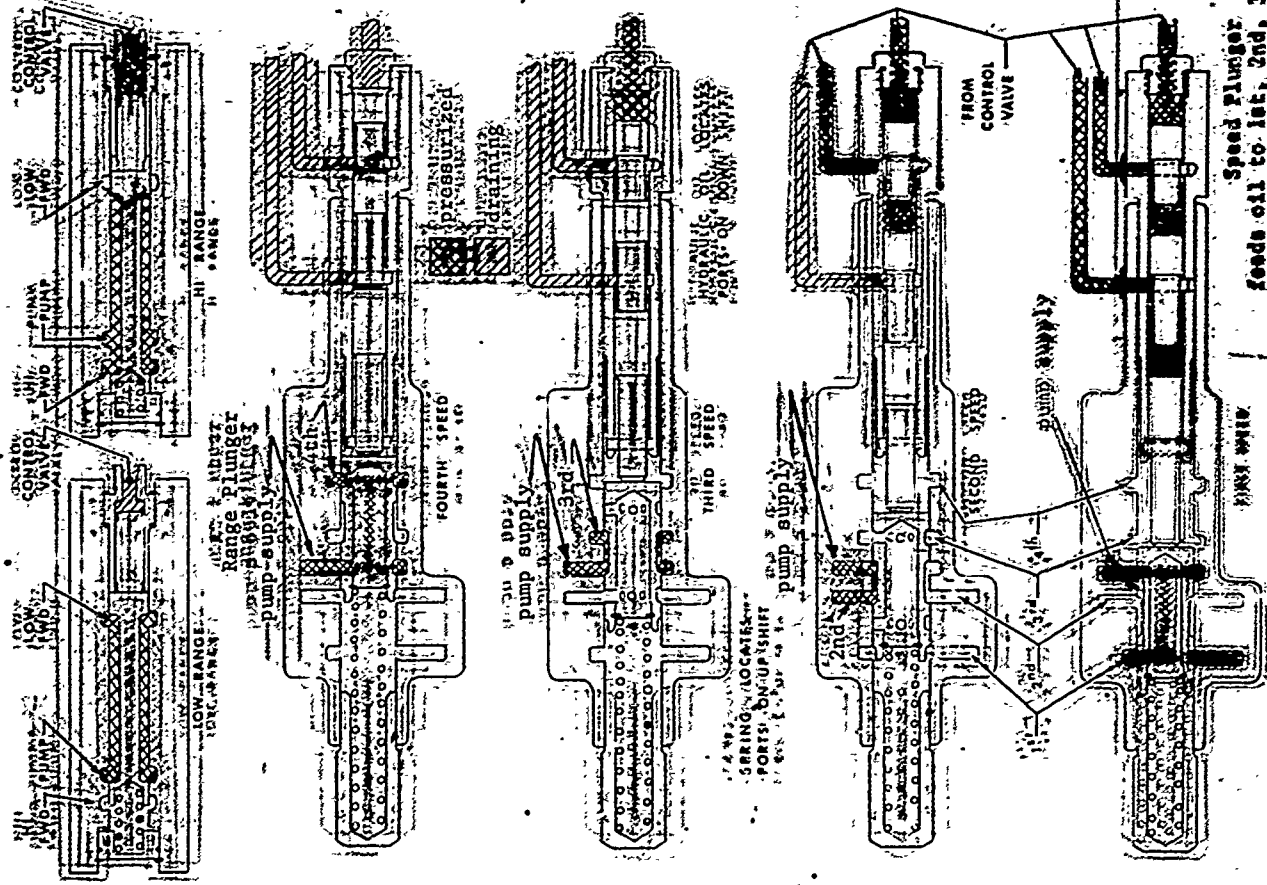

Speed Plunger feeds oil to Int, 2nd, 3rd, & 4th pump supply in different positions

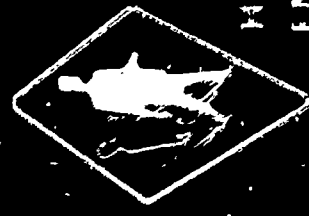

HUMAN ENGINEERING INSTITUTE

INSTRUCTOR'S GUIDE

Title of Unit: MICHIGAN/CLARK TRANSMISSION --
HYDRAULIC SHIFT

AM 2-23
9/25/67

OBJECTIVES:

1. To explain shifting of the Michigan/Clark transmission by covering the linkage from the operator's cab to the unit.
2. To introduce the 8 speed hydraulically operated speed control valve.

LEARNING AIDS suggested:

VU CELLS:

- AM 2-23 (1) Mechanical and Hydraulic Linkage
- AM 2-23 (2) Hydraulic Connections
- AM 2-23 (3) Control Valve
- AM 2-23 (4) Breakdown of Shift Control Valve
- AM 2-23 (5) Breakdown of Transmission Control Cover
- AM 2-23 (6) Eight Speed Hydraulic Shift Transmission Cover
- AM 2-23 (7) Range Valve and Speed Valve in Different Positions

NOTE TO INSTRUCTOR:

Only one Vu Cell of the control valve (AM 2-23 (3)) accompanies this unit, rather than all eight positions.

MODELS:

Arrangements can be made to have a working model of a Michigan/Clark transmission at your center. A tear-down and assembly of this equipment on a class participation basis would be excellent for teaching purposes during these discussions.

QUESTIONS DESIGNED FOR GROUP PARTICIPATION:

1. Which of the following is operated entirely by mechanical linkage: (1) the vehicle directional changes, or (2) the vehicle speed changes?
2. Is the speed change lever the bottom one on the steering column?
3. Where is the control valve located? By what means is this valve changed from the steering column?

4. What function does the control valve perform?
5. How many positions does the directional control lever have? What are they?
6. What purpose does the check valve serve in this system?
7. What purpose does the accumulator serve in this system?
8. How many pressure hoses connect the control valve to the speed selector valve?
9. Is the same oil pressure that is used to shift the spools also used to engage the clutches?