

R E P O R T R E S U M E S

ED 021 097

VT 005 680

AUTOMOTIVE DIESEL MAINTENANCE 1. UNIT XXVI, I--CATERPILLAR LUBRICATION SYSTEMS AND COMPONENTS, II--LEARNING ABOUT BRAKES (PART I).

HUMAN ENGINEERING INSTITUTE, CLEVELAND, OHIO

REPORT NUMBER AM-1-26

PUB DATE 1 SEP 66

MINNESOTA STATE DEPT. OF EDUCATION, ST. PAUL

EDRS PRICE MF-\$0.25 HC-\$1.36 32P.

DESCRIPTORS- *STUDY GUIDES, *TEACHING GUIDES, *TRADE AND INDUSTRIAL EDUCATION, *AUTO MECHANICS (OCCUPATION), *DIESEL ENGINES, ADULT VOCATIONAL EDUCATION, TRANSPARENCIES, PROGRAMED MATERIALS, INDIVIDUAL INSTRUCTION, INSTRUCTIONAL FILMS, PROGRAMED INSTRUCTION, MOTOR VEHICLES, EQUIPMENT MAINTENANCE,

THIS MODULE OF A 30-MODULE COURSE IS DESIGNED TO DEVELOP AN UNDERSTANDING OF THE FUNCTIONS OF DIESEL ENGINE LUBRICATION SYSTEMS AND COMPONENTS AND THE PRINCIPLES OF OPERATION OF BRAKE SYSTEMS USED ON DIESEL POWERED VEHICLES. TOPICS ARE (1) THE NEED FOR OIL, (2) SERVICE CLASSIFICATION OF OILS, (3) CATERPILLAR LUBRICATION SYSTEM COMPONENTS (4) PRINCIPLES OF OPERATION (BRAKES), (5) BRAKE FRICTION PRINCIPLE, (6) BRAKE CONTROL SYSTEM, AND (7) INSPECTION OF BRAKES. THE MODULE CONSISTS OF A SELF-INSTRUCTIONAL BRANCH PROGRAMED TRAINING FILM "CATERPILLAR LUBRICATION SYSTEMS AND COMPONENTS" AND OTHER MATERIALS. SEE VT 005 655 FOR FURTHER INFORMATION. MODULES IN THIS SERIES ARE AVAILABLE AS VT 005 655 - VT 005 684. MODULES FOR "AUTOMOTIVE DIESEL MAINTENANCE 2" ARE AVAILABLE AS VT 005 685 - VT 005 709. THE 2-YEAR PROGRAM OUTLINE FOR "AUTOMOTIVE DIESEL MAINTENANCE 1 AND 2" IS AVAILABLE AS VT 006 006. THE TEXT MATERIAL, TRANSPARENCIES, PROGRAMED TRAINING FILM, AND THE ELECTRONIC TUTOR MAY BE RENTED (FOR \$1.75 PER WEEK) OR PURCHASED FROM THE HUMAN ENGINEERING INSTITUTE, HEADQUARTERS AND DEVELOPMENT CENTER, 2341 CARNEGIE AVENUE, CLEVELAND OHIO 44115. (HC)

STUDY AND READING MATERIALS

AUTOMOTIVE DIESEL MAINTENANCE

1

ED021097

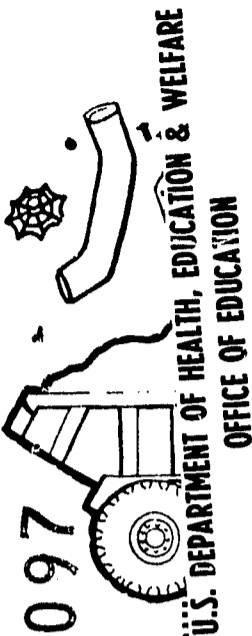

THIS DOCUMENT HAS BEEN REPRODUCED EXACTLY AS RECEIVED FROM THE PERSON OR ORGANIZATION ORIGINATING IT. POINTS OF VIEW OR OPINIONS STATED DO NOT NECESSARILY REPRESENT OFFICIAL OFFICE OF EDUCATION POSITION OR POLICY.

I -- CATERPILLAR LUBRICATION SYSTEMS AND COMPONENTS,

II -- LEARNING ABOUT BRAKES (PART I)

UNIT XXVI

Part I

SECTION A
SECTION B
SECTION C

THE NEED FOR OIL
SERVICE CLASSIFICATION OF OILS
CATERPILLAR LUBRICATION
SYSTEM COMPONENTS

Part II

SECTION A
SECTION B
SECTION C
SECTION D

PRINCIPLE OF OPERATION
(FRICTION)
BRAKE FRICTION PRINCIPLE
BRAKE CONTROL SYSTEM
INSPECTION OF BRAKES

AM 1-26
9/1/66

Human Engineering
Institute.

Minn. State Dept. of Ed.
Vocational Education

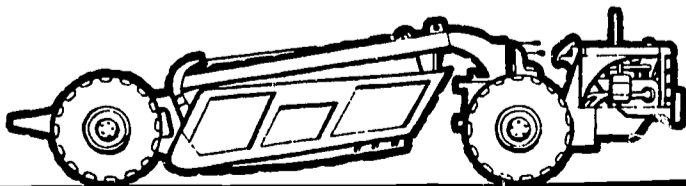
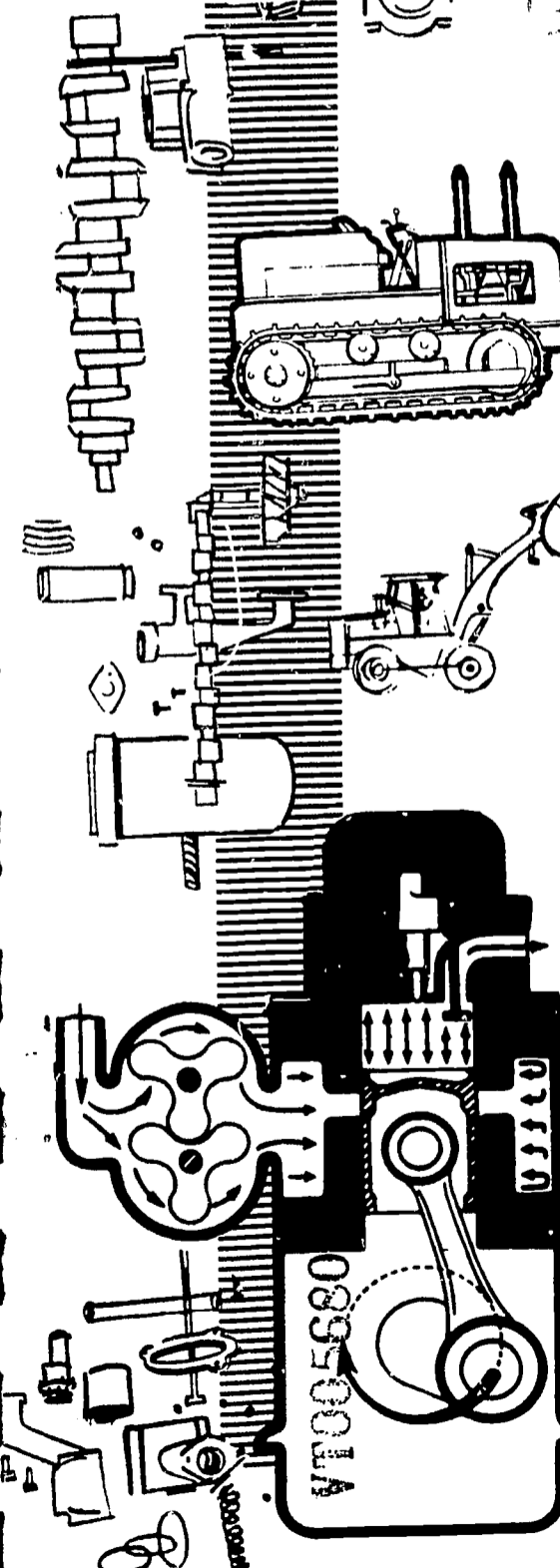

HUMAN ENGINEERING INSTITUTE

This unit is divided into two parts. The first part covers the CAT lubrication system and its components. The second part is the first of two parts covering discussion of brakes.

I -- CATERPILLAR LUBRICATION SYSTEMS AND COMPONENTS

SECTION A -- THE NEED FOR OIL

We normally think of lubricating oil as a substance that makes possible minimum wear or low frictional loss between two moving surfaces. However, the lubricating oil circulating through the engine to all moving parts requiring lubrication performs other jobs. The lubricating oil must:

1. Lubricate moving parts to minimize wear.
2. Lubricate moving parts to minimize power loss from friction.
3. Remove heat from the engine by acting as a cooling agent.
4. Absorb shock between bearings and other engine parts, thus reducing engine noise and extending engine life.
5. Form a good seal between the piston rings and cylinder walls.
6. Act as a cleaning agent.

A satisfactory engine lubricating oil must have certain characteristics, or properties. It must have the proper viscosity (body and fluidity) and must resist oxidation, carbon formation, corrosion, rust, extreme pressure, and foaming. Also it must act as a good cleaning agent, must pour at low temperatures, and must have good viscosity at extremes of high and low temperature.

ADDITIVES -- A mineral oil, by itself, does not have all of these properties. Lubricating oil manufacturers therefore put a number of additives into the oil during the manufacturing process. An oil for severe service may have many additives, such as:

1. Pour-point depressants
2. Oxidation inhibitors

3. Corrosion inhibitors
4. Rust inhibitors
5. Extreme-pressure agents
6. Detergents-dispersants
7. Foam inhibitors
8. Usually a viscosity-index improver

VISCOSITY (BODY AND FLUIDITY) -- Primarily, viscosity is the most important characteristic of lubricating oil. Viscosity refers to the tendency of oil to resist flowing. In a bearing and journal, layers of oil adhere to the bearing and journal surfaces. These layers must move, or slip, with respect to each other, and the viscosity of the oil determines the ease with which this slipping takes place. Viscosity may be divided for discussion into two parts, body and fluidity. **BODY** has to do with the resistance to oil-film puncture, or penetration, during the application of heavy loads. When the power stroke begins, for example, bearing loads sharply increase. Oil body prevents the load from squeezing out the film of oil between the journal and the bearing. This property cushions shock loads, helps maintain a good seal between piston rings and cylinder walls, and maintains an adequate oil film on all bearing surfaces under load.

FLUIDITY has to do with the ease with which the oil flows through oil lines and spreads over bearing surfaces. In some respects, fluidity and body are opposing characteristics, since the more fluid an oil is, the less body it has. The oil used in any particular engine must have sufficient body to perform as explained in the previous paragraph, and yet must have sufficient fluidity to flow freely through all the lines and to spread effectively over all bearing surfaces. Modern engines have closely fitted bearings with small clearances and require oils of great fluidity, that will flow readily into the space between bearings and journals. Such engines use oils of low viscosity.

Temperature influences viscosity. Increasing temperature reduces viscosity; it causes oil to lose body and to gain fluidity. Decreasing

temperature causes oil viscosity to increase. The oil gains body and loses fluidity.

Since engine temperature ranges several hundred degrees from cold weather starting to operating temperature, a lubricating oil must have adequate fluidity at low temperatures so that it will flow. At the same time, it must have sufficient body for high temperature operation.

VISCOSITY RATINGS -- Viscosity of oil is determined by use of a **VISCOSIMETER**, a device that determines the length of time required for a definite amount of oil to flow through an opening of a definite diameter. Temperature is taken into consideration during this test, since high temperature decreases viscosity, while low temperature increases viscosity. In referring to viscosity, the lower number refers to oils of lower viscosity (thinner).

The Society of Automotive Engineers (SAE) rates oil viscosity in two different ways, for winter and for other than winter. Winter grade oils are tested at 0° and 210° F. There are three grades, SAE 5W, SAE 10W and SAE 20W, the "W" indicates winter grade. For other than winter use, the grades are SAE 20, SAE 30, and SAE 40 and SAE 50, all without the "W" suffix. Some oils have multiple ratings, which means they are equivalent, in viscosity, to several single rating oils. An SAE 10W-30 oil for example, is comparable to SAE 10W, SAE 20W and SAE 30 oils. This oil has a high viscosity index (such oil shows relatively little change in viscosity from very low to relatively high temperatures).

Where diesel engines are operating under conditions that cause troublesome ring sticking, or bearing corrosion, compounded oils containing special chemicals, called "additives" are used. These additives are intended to improve the oxidation resistance* of the oil and also to give it special detergent-dispersant properties.

*Oxidation resistance has been defined as that property which opposes chemical changes in an oil due to oxygen in the air and the action of heat.

SECTION B -- SERVICE CLASSIFICATION OF OILS

The American Petroleum Institute (API) has adopted a general classification of diesel lubricating oils for high-speed diesels as follows:

- DG - suitable for general and light duty service.
- DM - suitable for severe service when using low-sulfur fuel.
- DS - suitable for severe service when using high-sulfur fuel.

It should be noted that these designations, developed in conjunction with the Society of Automotive Engineers (SAE), were intended only for application to high-speed engines, and are not necessarily valid for the larger types.

Evaluation of heavy duty oils may be made by an engine test adopted by the Cooperative Research Council. This test is made in a single cylinder Caterpillar diesel engine which is operated for 480 hours under specified conditions and load. Results of the test are evaluated into a numerical "detergency level" rating on the basis of condition of the piston and rings at the end of the test.

This was referred to originally as the CRC L-1 test. It was used in connection with the former U S Military Specification MIL-2104B, where the sulfur content of the fuel was specified not more than 0.4%. This specification was superceded by MIL-0-2104 and later by MIL-L-2104-A, the current specification. The fuel requirement was changed to not less than 0.35% sulfur, and less carbon and lacquer deposits were permitted on piston and rings than previously.

Later requirements for lubricating oil to meet more severe operating conditions caused development of a "Supplement 1" test which required a fuel having 0.95% to 1.05% sulfur content.

A still more severe test, using the same fuel with supercharging and higher engine temperatures and speed, was used to qualify oils as "Series 2" lubricants. Need for oils to meet still more severe requirements led to an Improved Series 2 and finally a "Series 3" lubricant. The Series 2 oil classification has been dropped, leaving the Supplement 1 and Series 3 classification in addition to the MIL specification oil. Most diesel powered trucks and tractors use supplement I oils -- with the exception of those powered by GM diesels. The factory (GM) recommends not using series 3 oils. Only CAT requires that series 3 be used in their engines.

Designation of oils that are common in use by oil companies and engine builders are listed in Table I. It should be noted that MIL specifications are about the same as the heavy duty (HD) classification. Many HD oils have not been qualified under the military specification for various reasons, although they are of equal or better quality and could qualify. "Detergency level" is only an approximate numerical grading of effectiveness and is not intended to indicate percentage of additive or any other absolute value.

Quality, Or Test	Approximate API Classification	Detergency Level
Regular	DG	1
Premium	DG	2
Mil-L-2104A	DM	4
or		
H-D		
Supplement 1	DM	8
Series 3	DS	24

Table 1 Relative detergency of oils.

CAUTION: Do not confuse viscosity and service ratings of oil. Some people think that a high viscosity oil is a "heavy duty" oil. This is not necessarily so. Viscosity ratings have been mentioned before, and refer to the thickness of the oil; thickness is not a measure of heavy duty quality. Remember that there are two ratings, viscosity and service. Thus, an SAE 10 oil can be an MS, MM, or ML oil. Also, an oil of any other viscosity rating can have any one of the three service ratings (MS, MM, or ML), or an oil of any viscosity rating can have any one of the three service ratings for diesel engines (DS, DG, and DM).

In commercial practice, lubrication must be provided for a large variety of machines and under a great variety of conditions of temperature, pressure, speed, atmosphere, etc. All lubricants must have certain properties in common, and some necessarily must have qualities not possessed by others.

Naturally enough, certain unsound conceptions have found root in the minds of some users of oil, which we feel should be dispelled here. It is not an uncommon occurrence to receive requests for oils meeting certain specifications (or tests) which every lubrication engineer knows would, if furnished, prove wholly unsuited for the purpose. Particular stress is laid on such tests as flash, fire, viscosity, carbon residue, etc., apparently without a complete understanding of their significance and their worth in the application for which the oil is intended.

These tests, and sometimes others, are made by refiners to assure uniformity of their products and for identification purposes. To the experienced with a knowledge of oil chemistry these, along with special tests designed to correlate with service experience, can prove useful, when properly evaluated. Otherwise they may not be of value, and often are not. For sound council in such matters it is safer, in most cases, for the user to lean on the advise of one versed in petroleum technology who at the same time has had considerable practical lubrication experience, and who is familiar with the operation and the operating conditions involved.

USED OIL ANALYSIS -- Used oil analysis can be enlightening to the oil technician in analyzing lubrication problems. It gives him a good idea of the conditions to which the oil has been exposed that may have escaped the operator's notice.

SECTION C -- CATERPILLAR LUBRICATION SYSTEM COMPONENTS

OIL PUMP -- See Figure 1. The three section oil pump (3) is secured to the oil pan front section (5) and is driven through a splined coupling (2) by an oil pump drive assembly (1) which is secured to the oil pan front section. The oil pump drive assembly is driven by the crankshaft gear.

The lubrication system includes a rear suction bell (7), main suction bell (6) and a front suction bell (4).

The front suction bell and rear suction bell can be removed only after the oil pan has been removed.

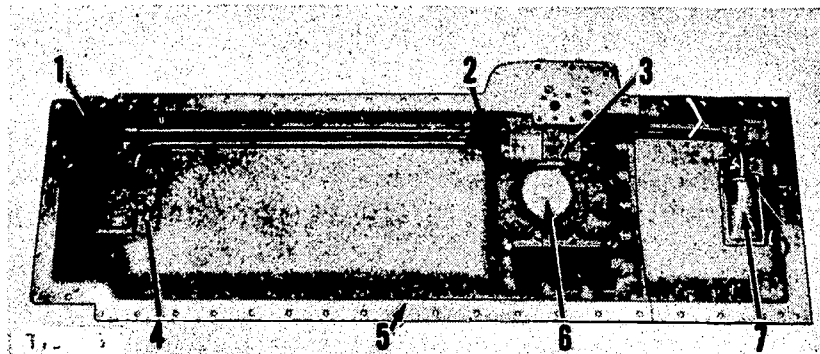

1-Oil pump drive assembly. 2-Splined coupling. 3-Oil pump. 4-Front suction bell. 5-Oil pan front section. 6-Main suction bell. 7-Rear suction bell.

Fig. 1 Oil pump and drive assembly.

Figure 2 shows the operation of the controlled inlet type oil pump. The oil pump is a gear type of positive displacement pump. By controlling the inlet, the oil pressure at the bearings is limited to approximately 30 psi at rated engine speed, in the following manner.

An oil passage from the oil manifold (2) returns oil to a spring-loaded

piston (4), which acts as a valve. As oil pressure on the piston increases, the piston is moved over the inlet (3) to the pump, reducing the amount of oil entering the pump, and thereby preventing a further rise of pressure. If the pressure in the oil manifold (2) falls below normal, the spring moves the piston away from the inlet (3), allowing a greater amount of oil to enter the pump, which results in an increase in pressure.

A spring loaded ball type relief valve (1) is located on the discharge side of the pump to prevent excessive pressure when the oil is cold or the flow restricted. This valve is set to open at 90 psi, and is non-adjustable. This feature gives high oil pressure, when the engine is started, to get the oil flowing as soon as possible.

A pressure operated turbocharger lubrication valve (20), Figure 3, having two inlet connections, one directly from the oil pump, and the other from the oil filter base, supplies the initial turbocharger lubrication upon starting. When starting the engine, and until the system oil pressure reaches the normal operating range, the valve directs oil under pressure directly from the oil pump to the turbocharger bearings. When the oil pressure in the system reaches normal operating pressure, the valve switches and directs filtered oil from the oil filter base to the turbocharger.

OIL PRESSURE -- When the engine is warm and running at rated speed, the gauge should register in the "operating range." A lower pressure reading is normal at low idling speed.

If for any reason the oil gauge registers no pressure, the engine should be stopped immediately, until the difficulty can be determined and corrected.

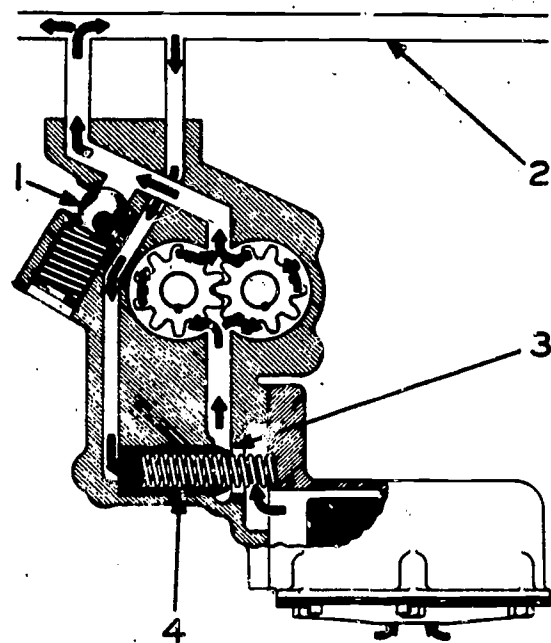

1-Pressure relief valve. 2-Oil manifold. 3-Inlet.
4-Spring-loaded piston.

Fig. 2 Flow of oil through oil pump.

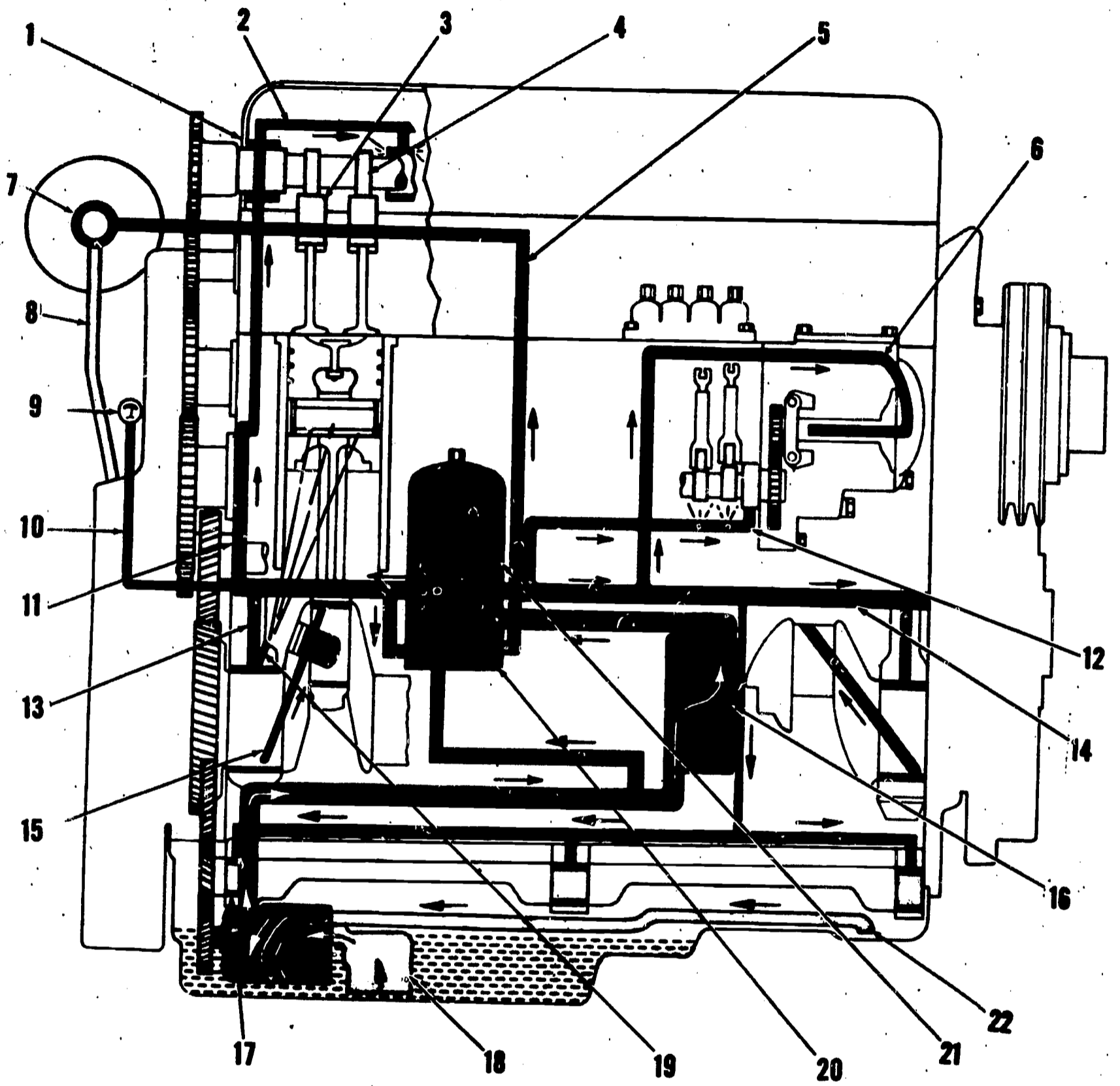

1-Camshaft rear bearing.
 2-Camshaft oil manifold.
 3-Cam follower.
 4-Camshaft cam lobe.
 5-Turbocharger oil supply line.
 6-Passage in governor housing.

7-Turbocharger bearing.
 8-Turbocharger oil return line.
 9-Oil pressure gauge.
 10-Line from oil manifold to gauge.
 11-Tube supplying lubricant to valve mechanism.

12-Fuel injection pump housing oil manifold.
 13-Passage in block to crankshaft bearing.
 14-Oil distribution manifold.
 15-Drilled passage in crankshaft oil supply to connecting rod bearing.

16-Engine oil cooler.
 17-Balancer shaft rear bearing.
 18-Suction bell on oil pump.
 19-Spray jet to cool pistons.
 20-Turbocharger lubrication valve.
 21-Oil filter assembly.
 22-Scavenge tube.

Fig. 3 Flow of lubricating oil.

OIL PUMP CATERPILLAR 824 -- The oil pump is mounted on the bottom of the cylinder block at the rear of the engine. The pump drive gear is driven by the left balancer shaft gear.

The two section pump consists of a pressure pump, which circulates the oil through the lubricating system, and a scavenger pump, which returns the oil to the main pump from the front of the engine.

A non-adjustable pressure regulating valve maintains approximately 52 psi oil pressure at the gauge.

ENGINE OIL COOLER -- The oil cooler is mounted beneath the oil filter base, on the right side of the engine near the front cylinder block.

Coolant from the diesel engine cooling system is circulated through the oil cooler prior to entering the cylinder block.

The oil enters the oil cooler at the rear, circulates through the cooler and flows out the top into the filter base, where it circulates through the filters and enters the oil manifold. See Figure 4.

Flow of oil through the oil cooler, base, and oil filter -

Unfiltered oil is delivered by the oil pump (6) through a passage in the cylinder block and then through an external line into the oil cooler (1). The unfiltered oil is cooled and then flows through an external

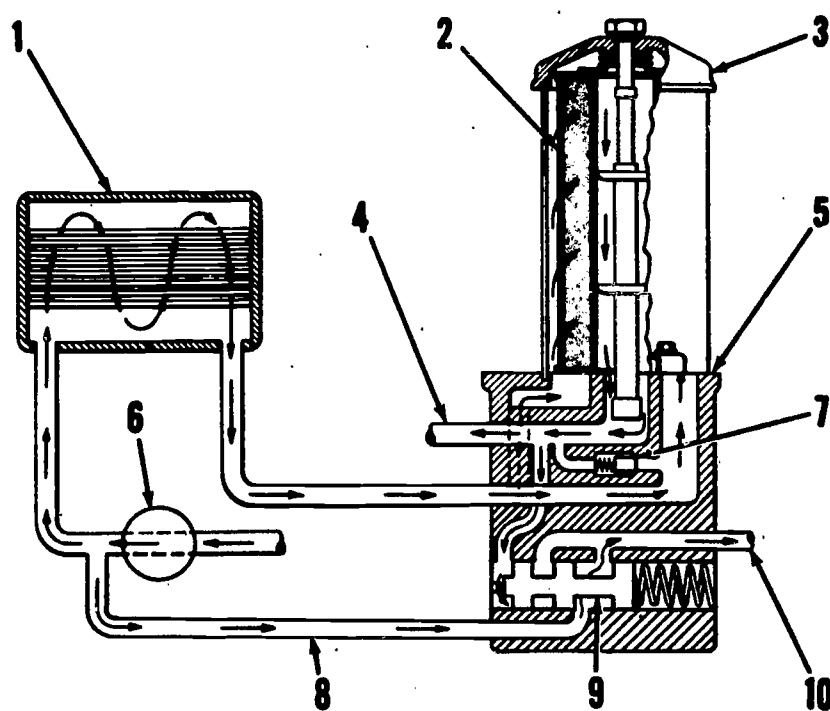

1-Oil cooler. 2-Filter element. 3-Oil filter. 4-Passage. 5-Filter base. 6-Oil pump. 7-Oil filter by-pass valve. 8-Turbocharger lubrication valve oil supply line (unfiltered oil). 9-Turbocharger lubrication valve. 10-Turbocharger oil supply line.

Fig. 4 Flow oil through oil cooler, base and oil filter.

line to a passage in the filter base (5) and then to the oil filter (3). The oil is filtered as it passes through the filter element (2). The filtered oil is transmitted through the passage (4) in the filter base, to the engine oil distribution manifold.

As on other CAT engines equipped with turbochargers, a turbocharger lubrication valve (9), which is located in the filter base, provides instantaneous lubrication to the turbocharger upon initial starting. On starting, oil passes through the line (8), past the valve (9) and through the line (10) to the turbocharger. When the pressure of the oil in the filter base reaches normal operating pressure, the valve (9) simultaneously closes the passage from the oil pump and opens the passage from the oil filter base to the turbocharger.

If the oil filters should become restricted, excessive pressure will unseat the oil filter by-pass valve (7), permitting the oil to by-pass the filters and flow directly into the engine.

II -- LEARNING ABOUT BRAKES (PART I)

SECTION A -- PRINCIPLE OF OPERATION (FRICTION)

FRICTION -- To understand and appreciate brakes and how to properly care for them, let's review some basic principles about friction. Friction varies according to the pressure applied between the sliding surfaces, the roughness of the surfaces, and the material of which the surfaces are made. Suppose, for example, that a platform and its load weigh 100 pounds and that it takes 50 pounds of pull to move it along the floor; see Figure 5. If the load was reduced so the platform and its load weighed only 10 pounds, you would find that it required only 5 pounds pull to move it along the floor.

If the floor and the sliding part of the platform were sanded to a smooth finish, then even less pull would be required. **FRICION VARIES WITH THE LOAD.**

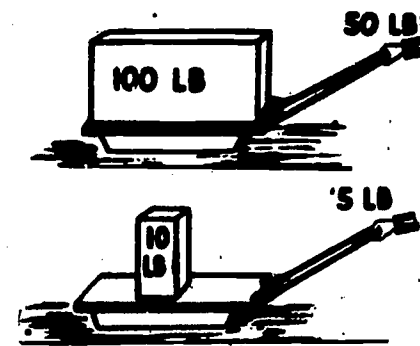

Fig. 5 Friction varies with the load.

Friction also varies with the type of material. For example, if you dragged a 100 pound bale of rubber across a concrete floor, you might find that it required a pull of 70 pounds. But to drag a 100 pound cake of ice across the same floor might require a pull of only 2 pounds. **FRICION VARIES WITH THE TYPE OF MATERIAL.** The measure of friction is expressed as the coefficient of friction: the higher the coefficient of friction the more force necessary to cause movement.

TYPES OF FRICTION -- It requires more force to put an object into motion than it does to keep it in motion. A vehicle requires more torque when moving from a dead stop position than it does after it is motion.

Friction at rest is referred to as **STATIC** friction, while friction of motion is referred to as **KINETIC** friction.

SECTION B -- BRAKE FRICTION PRINCIPLE

The friction between the brake drums and brake shoes slows or stops the vehicle. This friction slows the rotation of the wheels, and then friction between the tires and road surface slows the motion of the vehicle. Note that it is the friction between the tires and the road that results in the stopping of the vehicle. Also if the brakes are applied so hard that the wheels lock in place, then the friction between the tires and road is kinetic (friction of motion as the tires skid on the road).

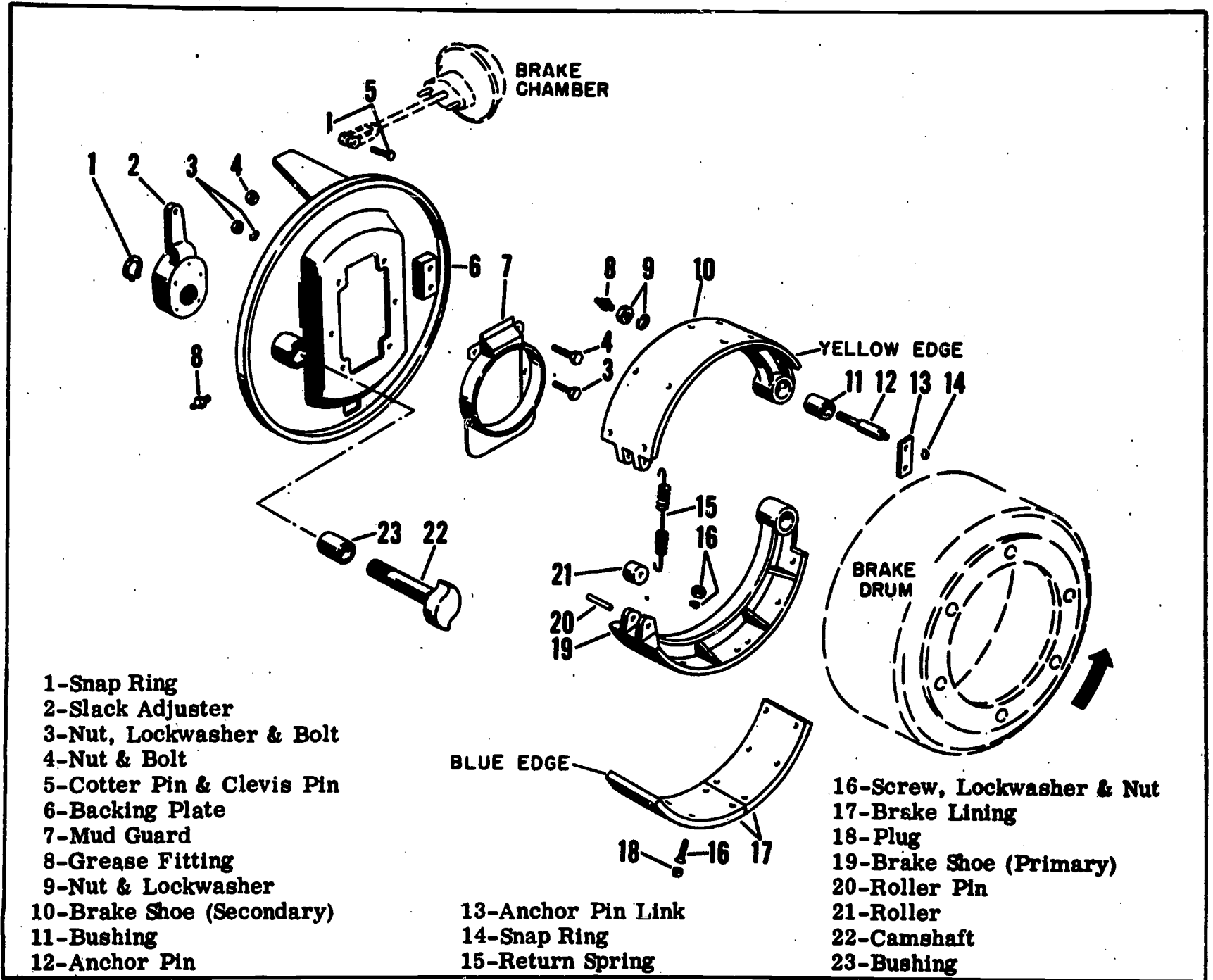

Fig. 6 Exploded view of front wheel brake assembly.

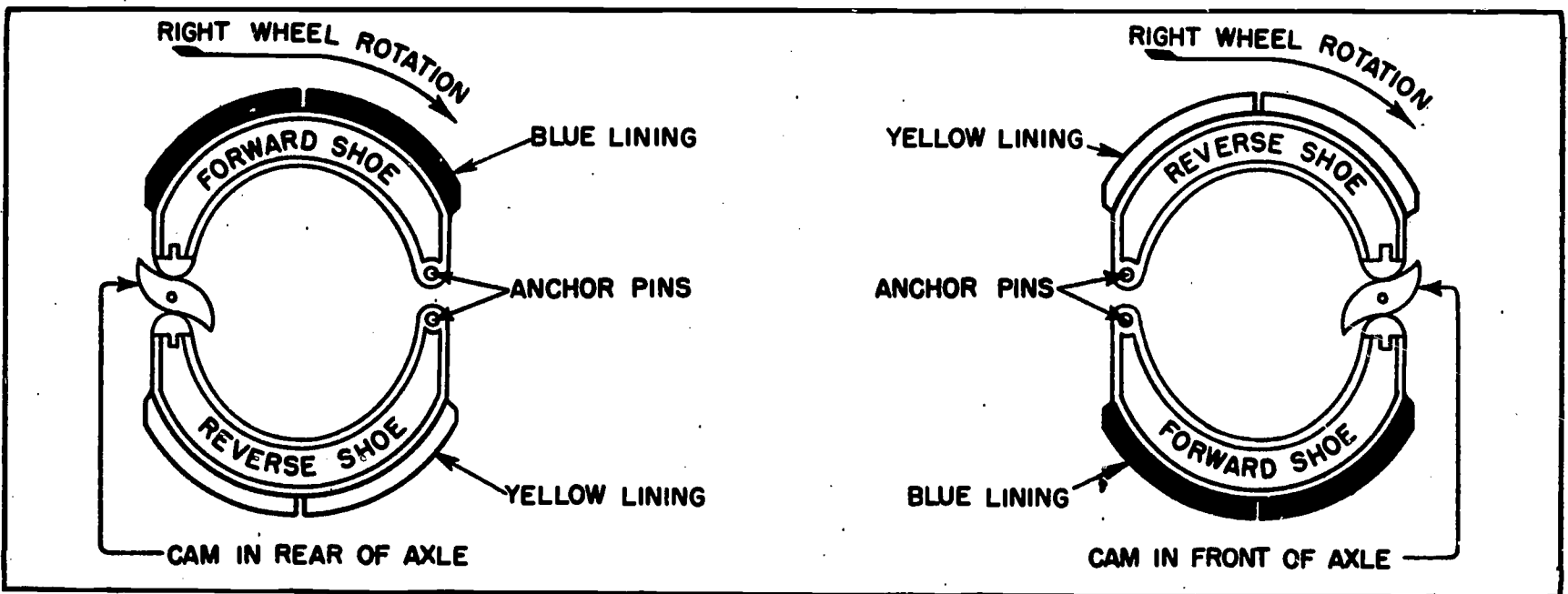

Fig. 7 Combination brake lining.

Therefore if the wheels are allowed to rotate while braking is occurring, there is a much greater braking effect. In other words, the vehicle will stop much faster if the brakes are applied just enough to obtain maximum static friction.

SECTION C -- BRAKE CONTROL SYSTEM

Figure 6 shows an exploded view of a typical off highway front wheel brake assembly. It consists of: the brake shoes (10 and 19), on which the brake linings (17) are mounted; camshaft (22) to apply motion to the cam which spreads the brake shoes apart and forces the lining against the brake drum; return spring (15) to return the brake shoes to their original position; anchor pins (12) to hold the brake shoes in place and to provide a fulcrum for applying the force exerted by the camshaft; slack adjuster (2) to compensate for wear in the brake lining.

COMBINATION BRAKE LINING -- In Figure 7 is shown the combination brake lining which consists of two linings for the forward or primary shoe and two linings for the reverse or secondary shoe.

The forward or primary shoe is the shoe that opens by moving about the hinge or anchor pin in the same direction as the wheel turns. Therefore, it is the shoe that tries to wedge into the brake drum or be carried away from the cam by the turning of the drum. The reverse or secondary shoe is the opposite shoe.

LINING MATERIALS -- Brakes are lined with friction material composed chiefly of asbestos. Asbestos is a fibrous mineral consisting chiefly of calcium and magnesium silicates. There are a number of different varieties, of which that known as Chrysotile is most largely used for this purpose. It occurs in the form of rock, of which large quantities are mined particularly in the Province of Quebec, Canada. The material,

after being mined, is subjected to various mechanical processes to reduce it to the fibrous state, to remove impurities, and to grade the fibers according to length. From the standpoint of its use for brake linings, the most important physical property of asbestos undoubtedly is its high heat resistance, though, of course, its relatively high coefficient of friction in contact with iron or steel also is important. Heat begins to affect asbestos only at about 600F. At 1000 F the water of crystallization is driven off rapidly, and the material loses its crystalline structure.

METALLIC PADS -- In some applications, a series of metallic pads are used in place of asbestos lining. These brakes can withstand more severe braking and higher temperatures than asbestos and have less tendency to fade.

SECTION D -- INSPECTION OF BRAKES

The following rules are established for checking brakes and brake linings to ensure that the vehicle has maximum braking efficiency:

1. Check backing plate for cracks and bends. Replace if necessary.
2. Cams should be checked for flat spots. Flat spots on cams can cause serious pulling, especially in the front axle brakes.
3. Check for bent camshafts. Bent camshafts will tend to bind in the bushings; push the shoes open at an angle tending to bend the anchor pins and cause a taper wear pattern of the brake lining.
4. Check camshaft bushings or anchor pin bushings for excessive wear and replace if worn.
5. Check brake drums for cracks, checks, distortion and scored surfaces. Severely scored brake drums may be salvaged by re boring. The maximum the drums can be rebored is 3/16". Drums should be bolted to the hob or wheel when being rebored. With rebored drums, an oversized lining should be used. If oversize lining is not available, it will be necessary to shim the standard lining. A metal shim should be used between the shoe and lining to conduct the heat away from the lining. When using over-sized lining, each shoe must have added to

the original thickness **ONE HALF** the amount removed from the drum.

6. Check brake shoe rollers for binding. If they bind, clean and oil; if they still bind, the roller and pin should be checked for excessive wear. Replace, if excessively worn.
7. Clean all rust off face of brake shoes and smooth down bolt or rivet holes so lining will fit snugly.

This has been a brief description of brakes, their operating principles, and applications. More will be said about brakes in the next unit.

AM 1-26D
9/16/66

CATERPILLAR LUBRICATION SYSTEMS AND COMPONENTS

Human Engineering
Institute

Minn. State Dept. of Ed.
Vocational Education

Press A / Check to be sure timer is OFF.

This film lesson is designed to supplement class text AM 1-26 by covering the need for proper lubrication. In addition, there is a discussion of Caterpillar specification for lubricating oil, an identification of oil terms, and some maintenance tips for lubrication systems. The latter part of the film helps you check your knowledge of brakes and brake systems.

Press A 2

1

2

We normally think of lubricating oil as substance that makes possible minimum wear or low frictional loss between two moving surfaces. However, the lubricating oil circulating through the engine to all moving parts requiring lubrication performs other jobs as well.

The lubricating oil must:

1. Lubricate moving parts to minimize wear.
2. Lubricate moving parts to minimize loss from friction.
3. Remove heat from the engine by acting as a cooling agent.

Press A for more. 2-1 1

The lubricating oil also must:

4. Absorb shock between bearings and other engine parts, thus reducing engine noise and extending engine life.
5. Form a good seal between the piston rings and cylinder walls.
6. Act as a cleaning agent.

Press A 3

1

3

A satisfactory engine lubricating oil must have certain characteristics, or properties. It must have the proper viscosity (body and fluidity) and must resist oxidation, carbon formation, corrosion, rust, extreme pressure, and foaming. It must act as a good cleaning agent, must pour at low temperatures, and must have good viscosity at extremes of high and low temperatures.

Press A 4

1

4

Any mineral oil, by itself, does not have all of the necessary properties to be an ideal lubricant--or even a good one for diesel engines. Therefore, lubricating oil manufacturers put a number of _____ into the oil during the manufacturing process.

- A. inhibitors 5
- B. dispersants 5
- C. additives 6

1

5

No, the additives that the manufacturers put in the oil may contain dispersants and inhibitors, but all are considered as additives. Some of the additives that are put in oil improve it or make it meet certain engine manufacturers' specifications are as follows:

1. Pour-point depressants
2. Oxidation inhibitors
3. Corrosion inhibitors
4. Rust inhibitors
5. Extreme-pressure agents
6. Detergent-dispersants
7. Foam inhibitors
8. Usually a viscosity-index improver

Press A 6

1

6

OK.

Primarily, _____ is the most important characteristic of lubricating oil.

- A. rust inhibitor 7
- B. viscosity 8
- C. oxidation inhibitor 7

1

7
No; viscosity is the most important characteristic of lubricating oil.

Viscosity refers to the tendency of oil to resist flowing. In a bearing and journal, layers of oil adhere to the bearing and journal surfaces. These layers must move, or slip, with respect to each other, and the viscosity of the oil determines the ease with which this slipping takes place.

Press A 8

1

8
OK. Viscosity may be divided for discussion into two parts, body and fluidity. (1) has to do with the resistance to oil-film puncture, or penetration, during the application of heavy loads. (2) has to do with the ease with which the oil flows through oil lines and spreads over bearing surfaces.

- A. (1) Body (2) Fluidity 10
- B. (1) Fluidity (2) Body 7
- C. (1) Viscosity (2) Body 7

1

9
No; body has to do with the resistance to oil film puncture, or penetration, during heavy loads.

Fluidity has to do with the ease with which the oil flows through oil lines and spreads over bearing surfaces.

Press A 10

1

10
OK. In some respects, fluidity and body are opposing characteristics, since the more fluid an oil is, the less body it has.

Temperature influences viscosity. Increasing temperature reduces viscosity. That is, it causes oil to lose (1) and gain (2).

Decreasing temperature causes oil viscosity to increase.

- A. (1) fluidity (2) body 11
- B. (1) body (2) body 11
- C. (1) body (2) fluidity 12

1

11
No; increased temperature causes oil to lose body (thin out) and gain fluidity (flow easier).

Decreasing temperature causes oil viscosity to increase; the oil gains body and loses fluidity.

Press A 12

1

12
OK. Since engine temperature ranges several hundred degrees from cold weather starting to operating temperature, a lubricating oil must have adequate (1) at low temperatures so it will flow. At the same time, it must have sufficient (2) for high temperature operation.

- A. (1) fluidity (2) body 14
- B. (1) body (2) fluidity 14

The correct answer must be selected before you can move to the next frame.

X - C 13

1

13
You have missed one or more questions to this point and should go back for a review. Read the questions carefully and take your time in selecting an answer.

Press A 15

1

14
OK. Viscosity of oil is determined by use of a VISCOSIMETER a device that determines the length of time required for a definite amount of oil to flow through an opening of a definite diameter. Temperature is taken into consideration during the test, since high temperature decreases viscosity, while low temperature increases viscosity.

In referring to viscosity, the lower number refers to oils of lower viscosity (thinner).

Press A 15

2

15

The Society of Automotive Engineers (SAE) rates oil viscosity in two ways, for winter and for other-than-winter. Winter-grade oils are tested at zero degrees and 210 degrees F. There are three grades, SAE 5 W, SAE 10W, and SAE 20W; the "W" indicates winter grade. For other than winter use, the grades are SAE 20, SAE 30, SAE 40 and SAE 50, all without the "W" suffix.

Some oils have _____ ratings, which means they are equivalent, in viscosity, to several single rating oils. An SAE 10W-30 oil is an example.

- A. multiple 17
- B. variable 16
- C. mixed 16

2

16

No, some oils have multiple viscosity ratings.

An SAE 10W-30 oil for example, is comparable to SAE 10W, SAE 20W and SAE 30 oils. This oil has a high viscosity index (such oil shows relatively little change in viscosity from very low to relatively high temperatures).

Press A 17

2

17

OK. Diesel engines operating under conditions that cause troublesome ring sticking, or bearing corrosion, compounded oils containing special chemicals, called "_____" are used. These chemicals are intended to improve the oxidation resistance of the oil and also give it special detergent-dispersant properties.

- A. inhibitors 18
- B. dispersants 18
- C. additives 19

2

18

No, compounded oils containing special chemicals, called "additives," are used to improve diesel engine lubricating oils. There are about eight additives used in the process of manufacturing compounded oil. The eight were mentioned in a previous frame.

Press A 19

2

19

OK. _____ has been defined as that property which opposes chemical changes in an oil due to oxygen in the air and the action of heat.

- A. Rust inhibitor 20
- B. Oxidation resistance 21
- C. Corrosion inhibitor 20

2

20

No: oxidation resistance has been defined as that property which opposes chemical changes in an oil due to oxygen in the air and the action of heat.

Press A 21

2

21

OK. The American Petroleum Institute (API) has adopted a general classification of diesel lubricating oils for high speed diesels as follows:

- DG - Suitable for general and light duty service.
- DM - Suitable for severe service when using low sulfur fuel.
- DS - Suitable for severe service when using high sulfur fuel.

It should be noted that these designations were developed in conjunction with the _____.

- A. SAE 23
- B. API 22
- C. CRC 22

2

22

No, Society of Automotive Engineers (SAE) is the correct answer. Evaluation of heavy duty oils may be made by an engine test adopted by the Cooperative Research Council. This test is made in a single cylinder Caterpillar diesel engine which is operated under specified conditions and load. Results of the test are evaluated into numerical "detergency level" rating on the basis of the piston and rings at the end of the test.

Press A 23

2

23
OK. Evaluations of heavy duty oils may be made by an engine test adopted by the Cooperative Research Council. Results of the test are evaluated into numerical "detergency level" ratings on the basis of condition of the piston and rings at the end of the test. Test after test was conducted, and requirements for lubricating oil to meet more severe operating conditions caused development of "Supplement 1" and later the _____ lubricant.

- A. Supplement 2 24
- B. Supplement 1, Series 1 24
- C. Series 3 25

2

24
No. The need for oils to meet more severe requirements led to the Improved Series 2 and finally a "Series 3" lubricant. The Series 2 oil classification has been dropped, leaving the Supplement 1 and Series 3 classifications in addition to the MIL specification.

(MIL = Military.)

Press A 25

2

25
OK. Many HD oils have not been qualified under the MIL spec (military specification) for various reasons, although they are of equal or better quality and could qualify. "Detergency level" is only an approximate grading of effectiveness and is not intended to indicate percentage of _____ or any other absolute value.

- A. additive 26
- B. detergent 27
- C. effectiveness 26

2

26
No. "Detergency level" is only an approximate numerical grading of effectiveness and is not intended to indicate percentage of additive or any other absolute value. The classification HD means only, that the oil contains detergent. It may also contain other additives.

Press A 27

2

27
CAUTION: Do not confuse viscosity and service ratings of oil. Some people think that a high-viscosity oil is a "heavy duty" oil. This is not necessarily so. Viscosity ratings have been mentioned before, and refer to the thickness of the oil; thickness is not a measure of heavy duty quality. Remember, there are two ratings, viscosity and service. Thus, an SAE 10 oil can be an MS, MM, or ML oil. Likewise, an oil of any other viscosity rating can have any one of these three service ratings. Likewise, an oil of any viscosity can have any one of the three service ratings for diesel engines (DS, DG, and DM).

Press A 28

2

CATERPILLAR LUBRICATION SYSTEM COMPONENTS

28
The three section oil pump is secured to the oil pan front section and is driven through a splined coupling by a pump drive assembly, which is secured to the oil pan front section. The oil pump drive assembly is driven by the _____.

- A. camshaft gear and chain 29
- B. crankshaft gear 30
- C. timing chain 29

2

29
No, the oil pump is driven by the crankshaft gear, as shown in Fig. 1 of the text.

The oil pump is a gear type, positive displacement pump.

Press A 30

2

30
OK.

By controlling the inlet, the oil pressure at the bearings is limited to approximately 30 psi at rated engine speed, in the following manner:

An oil passage from the oil manifold returns oil to a spring-loaded piston which acts as a valve. As oil pressure on the piston increases, the piston is moved over the inlet to the pump, thereby preventing a further rise of pressure.

If the pressure falls below normal, as a result of increased temperature, etc., what happens to compensate for the loss of pressure?

Press A and choose one of the three answers for this question. 31

2

31

- A. The volume of the oil is such that no adjustment is necessary.
- B. If the pressure falls below normal, the spring moves the piston away from the inlet, allowing a greater amount of oil to enter the pump, which results in an increase in oil pressure.
- C. If the oil pressure falls below normal, an automatic cut-off switch stops the engine until the trouble can be corrected.

32

33

32

2

32

No, by controlling the inlet, the oil pressure is limited to approximately 30 psi at rated engine speed. Oil pressure from the discharge side of the pump acts on a piston that covers and uncovers the inlet oil to the pump. If the pressure falls below normal, a spring moves the piston away from the inlet, allowing a greater amount of oil to enter the pump, which results in an increase in pressure.

Press A 30

2

33

OK. A spring loaded ball-type relief valve is located on the discharge side of the pump to prevent excessive pressure when the oil is cold or flow is restricted. The valve is set to open at _____, and is non-adjustable.

- A. 120 psi 34
- B. 60 psi 34
- C. 90 psi 35

2

No; 90 psi is the correct answer for the last question. This feature gives high oil pressure when the engine is started, to get the oil flowing as soon as possible.

Press A 35

2

34

35

OK. A pressure operated lubrication valve having two inlet connections, one directly from the oil pump and the other from the oil filter base allows _____ to be supplied to the turbocharger at all times.

- A. filtered oil 36
- B. unfiltered oil 36
- C. (neither A or B) 37

2

No. When starting the engine, and until the system oil pressure reaches the normal operating range, the valve directs oil under pressure directly from the oil pump to the turbocharger bearings (unfiltered oil). However, when the system oil pressure reaches normal operating range, oil from the filter base forces the valve to move from it's seat and allows filtered oil to flow to the turbocharger bearings.

Press A 37

2

36

37

OK. When the engine is running at rated speed, in the normal operating temperature area, the oil pressure gauge should register in the _____. A lower pressure reading is normal at low idling speed.

- A. operating range 37
- B. safe range X X

The correct answer must be selected before you can move to the next frame.

2

You have missed one or more of the questions in this unit and should go back for a review. Read the questions carefully and take your time in selecting an answer.

Press A 28

2

38

39

40

Oil pump CATERPILLAR 824 -- The oil pump is mounted on the bottom of the cylinder block at the rear of the engine. The pump drive gear is driven by the _____.

No, the oil pump on the CAT 824 is driven by the left balancer shaft gear; not by a chain from the crankshaft gear or from the engine timing gear.

- A. engine timing gear 40
- B. chain from the crankshaft 40
- C. left balancer shaft gear 41

Press A 41

3

3

41

42

OK. The two section pump consists of a pressure pump, which circulates the oil through the lubricating system, and a _____ pump, which returns the oil to the main pump from the front of the engine.

No, the two section pump consists of a pressure pump and a scavenger pump, which returns the oil to the main pump from the front of the engine.

- A. scavenger 43
- B. secondary 42
- C. primary 42

Press A 43

3

3

43

44

OK. Frequent oil changes, good air filter maintenance, and conscientious engine maintenance should be carried out to extend the service life of the diesel engine and its component parts.

The next few frames will be a review of material covered in this and other lubricating systems texts.

Press A 44

Press A 45

3

3

45

46

Which of the following indicates viscosity? _____

- A. Color of the oil. 46
- B. How quickly the oil will heat up. 46
- C. How easily the oil will flow. 47

No, how easily an oil will flow indicates its viscosity. The color may have something to do with the detergent content, how long the oil has been in use, and if it is doing the job it was supposed to do.

Press A 47

3

3

47

48

OK. What is the pour point of an oil?

- A. The temperature at which the oil will no longer flow when it is cooled. 49
- B. The point at which the moving parts will break through the oil film. 48
- C. The time it takes a quart of oil to be poured through a 1/4 inch opening. 48

No, the pour point of an oil is the temperature at which the oil will no longer flow. As is well known, oils thin out rapidly when heated and thicken when cooled.

Press A 49

3

3

49

50

OK. As time passes, the oxygen in the air combines with the oil, and helps to form a sludge. This combining process is known as _____

- A. emulsification 50
- B. vaporizing 50
- C. oxidation 51

No, the hydrocarbons in the oil combine with oxygen in the air to form organic acids. The organic acids with low boiling points (volatile acids) are usually highly corrosive. The acids with high boiling points tend to form gum and lacquers. The process described is oxidation.

Press A 51

3

3

51

52

OK. Which of the following oils has the highest viscosity?

- A. SAE 30 52
- B. SAE 40 53
- C. SAE 10W-30 52

No; SAE 40 has the highest viscosity.

The SAE 30 is thinner and is naturally a lower viscosity oil.

The SAE 10W-30 is a multiple viscosity (a combination of several different viscosity oils).

Press A 53

3

3

53

54

OK. In general, _____ oils are required for low temperatures.

- A. high pour point oils 54
- B. medium weight oils 54
- C. light oils (low viscosity) 55

No, in general, light oils (low viscosity) are required for low temperatures, simply because a low viscosity oil offers less resistance to flow in the low temperatures, allows for easy starting, and still does the job of lubricating the engine properly.

Press A 55

3

3

55

56

OK. Oil oxidation resistance refers to

No, oxidation resistance refers to the extent to which the oil resists combining with the oxygen in the air.

A. the extent to which the oil resists combining with the oxygen in the air. 57

Press A 57

B. evaporation rates of various oils. 56

C. the degree to which iron oxide (in the form of rust and scale) will dissolve in heated oil. 56

3

3

57

58

OK. A Detergent oil is an oil

No, a detergent oil is one having cleansing agents present to prevent the formation of deposits. The detergent helps keep the would-be deposits in suspension so they can be drained off when the oil is changed.

A. having the ability to prevent metal-to-metal contact in spite of a break in the oil film. 58

B. containing animal fat oils permitting proper lubrication in presence of heat and water. 58

C. having cleansing agents present to prevent the formation of deposits. 59

3

Press A 59

3

59

60

OK.

Oils suitable for service DS originally were referred to as "Series 2" oils under a testing and approval program conducted by Caterpillar Tractor Co. Engine design modifications by this concern required oils of increased service performance. The engine tests were, therefore, increased in severity, and oils which pass this new test are now approved by Caterpillar as "Series 3" oils.

You have answered one or more of the questions in this sequence of material incorrectly. Review this data again and read carefully. Think before you answer.

Press A 61

Press A 44

3

3

XC - 60

61

62

Now let's discuss some BRAKE principles.

We know from experience and common sense that _____ is the only reason that brakes on vehicles work at all.

No. Although without hydraulics and pressure brakes on large vehicles would be inadequate, the real reason is FRICTION.

A. hydraulics 62

Press A 63

B. pressure 62

C. friction 63

4

4

63

OK. Without the physical properties of friction, brakes would be useless. Also, friction varies with the (1) _____, and also with the (2) _____.

- A. (1) speed (2) weight of vehicle 64
- B. (1) load (2) type of material 66
- C. (1) pressure (2) size of braking area 65

4

64

No. Speed and the weight of vehicle only mean that heavier duty brakes are required if stopping limits are to be held.

Try this question again.

Press A 63

4

65

No. The answer we want here is that friction varies with the load and type of material. Remember, we said there would be quite a difference between pulling an object across the floor and pulling the same object across ice.

Press A 66

4

66

OK. We know that a vehicle at rest requires more torque to put it in motion. This is called (1) _____ friction; while less torque is required to keep a vehicle moving once it is in motion. This is called (2) _____ friction.

- A. (1) stationary (2) permanent 67
- B. (1) static (2) kinetic 68
- C. (1) kinetic (2) static 67

4

67

No. Motionless friction is referred to as **STATIC**, while friction of motion is referred to as **KINETIC**.

Press B 68

4

68

OK. Remember that friction at rest is **STATIC**, and friction of motion is **KINETIC**.

Should the brakes on a vehicle lock in place while the vehicle is in motion, this would be (1) _____ friction, and much (2) _____ stopping or braking effect would occur.

- A. (1) static (2) more 69
- B. (1) kinetic (2) less 70
- C. (1) kinetic (2) more 69

4

69

No; when wheels lock in place, and tires skid, a condition of kinetic friction occurs, reducing the braking effect and increasing the stopping distance.

Press A 70

4

70

OK. The fastest way to stop a vehicle is to apply the brakes just enough to get maximum static friction (without sliding the tires).

There have been many discussions in the past few years about brakes "fading." Let's see why this happens and what has been done about it.

Press B 71

4

XC - 70-1

70-1

You have missed one or more questions in this sequence of material. Review this part again. Read carefully and think before answering the questions.

Press A 61

4

Brakes fade for one reason: the linings get too hot, and almost turn to a liquid if adequate cooling is not present.

During hard braking, under heavy load, the shoes may be pressed against the drum with pressures exceeding 1000 pounds. Since friction increases as the load (pressure) increases, this produces a strong frictional drag on the brake drum, and a great deal of heat is produced, often reaching temperatures above 500 degrees F.

Some manufacturers of very heavy vehicles have gone to the disk brake, which eliminates much of this problem.

Press A 72

4

71

72

Disk brakes will be discussed in the next unit. Briefly, they consist of a circular disk instead of a drum, and a pair of pads instead of brake shoes.

In operation, the pads are forced against the disk in a caliper action for the braking effect.

Press A 73

4

In review, we can say that brakes are mechanical devices for retarding the motion of the vehicle by means of friction, thereby changing the energy of motion into _____.

- A. kinetic friction 74
- B. static friction 75
- C. heat energy 76

4

73

74

No. We defined kinetic friction as friction of motion. The point here is that these mechanical devices (brakes) change energy of motion into energy of heat.

Press A 76

4

No. We defined static friction as friction at rest. The answer we want here is that brakes change energy of motion into energy of heat.

Press A 76

4

75

76

Correct. Remember that energy is never dissipated; it is only changed from one form to another. In this case it is changed from motion to heat.

Between the two types of brakes (disk and conventional), _____ operates by the contraction method.

- A. the disk 78
- B. the conventional 77
- C. neither type 77

4

No. You are incorrect. The conventional type uses the expansion principle of forcing the shoes against the drum by rotating the cam. See Figure 7 (8) in AM 1-26.

The disk type, as we said, contracts like a set of calipers, grasping the disk as you would a piece of paper.

Press A 78

4

77

78

OK. The disk type brakes are like calipers which grab the disk under pressure, forcing it to stop. Which type of brake would you think is more efficient?

- A. disk type **80**
- B. conventional type **79**

4

79

No. Perhaps this question was unfair at this time. However, the disk brake is more efficient, due to heat dissipation capabilities and area of friction available. More will be said about this in later films.

Press A **80**

4

80

OK. Disk brakes are more efficient because of their heat dissipation capabilities and area of friction available. More will be covered on this subject later in the program.

You have completed this lesson; congratulations!

Press REWIND. - **REWIND**

4

AM 1-26
①

TYPES OF BEARING FAILURES



AW 1-26

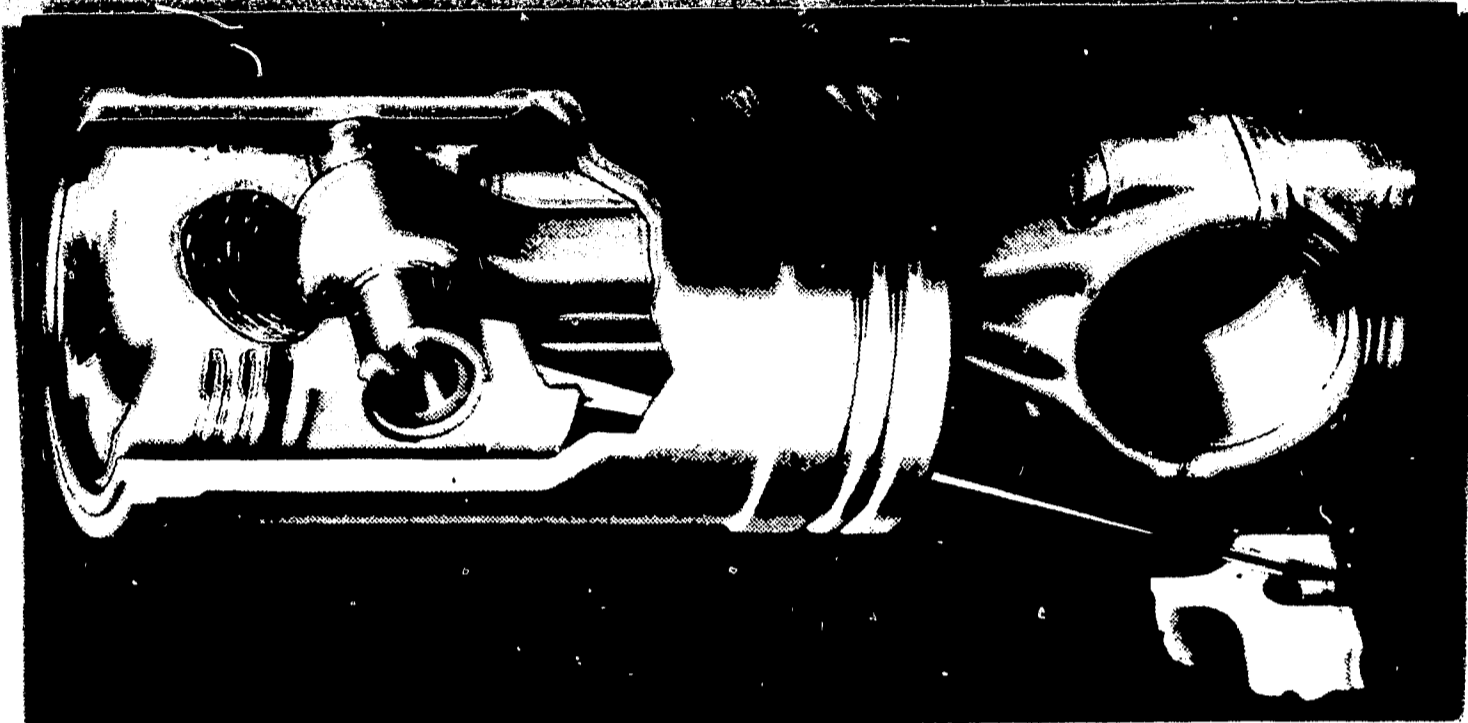

Section of
Caterpillar alumi-
num piston with
cast-in cast-iron
ring band and
cooling-oil jet.

Lubricating System
FLOW OF LUBRICATING OIL

AMA 1-36

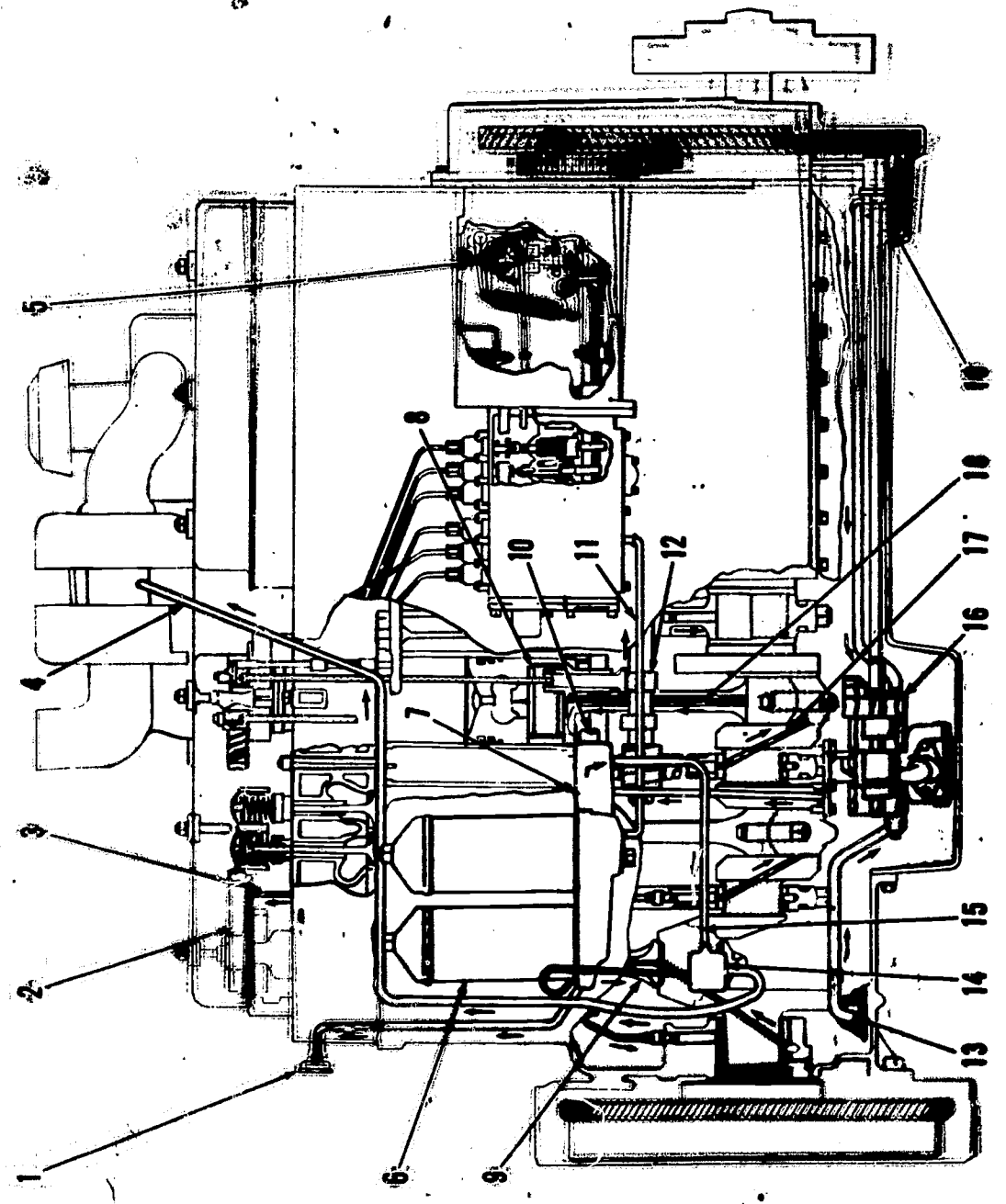

- FLOW OF LUBRICATING OIL**
- 1-Oil pressure gauge.
 - 2-Rear rocker arm shaft.
 - 3-Oil tube from distribution manifold to rear rocker arm shaft (connects to the front rocker arm shaft).
 - 4-Turboscharger oil supply line (return line on left side of turbocharger).
 - 5-Governor.
 - 6-Oil filter assembly.
 - 7-Oil filter base.
 - 8-Piston pin bearing.
 - 9-Filtered oil supply line to turboscharger lubrication valve.
 - 10-Oil distribution manifold.
 - 11-Fuel injection pump housing oil supply line.
 - 12-Crankshaft.
 - 13-Rear scavenger suction ball valve.
 - 14-Turboscharger lubrication valve.
 - 15-Quarantined oil supply line to turboscharger lubrication valve.
 - 16-Three-section oil pump.
 - 17-Drilled passage in crankshaft.
 - 18-Connecting rod drilled passage.
 - 19-Front scavenger suction ball.

AIM 1-26 (A)

ENGINE LUBRICATING SYSTEM

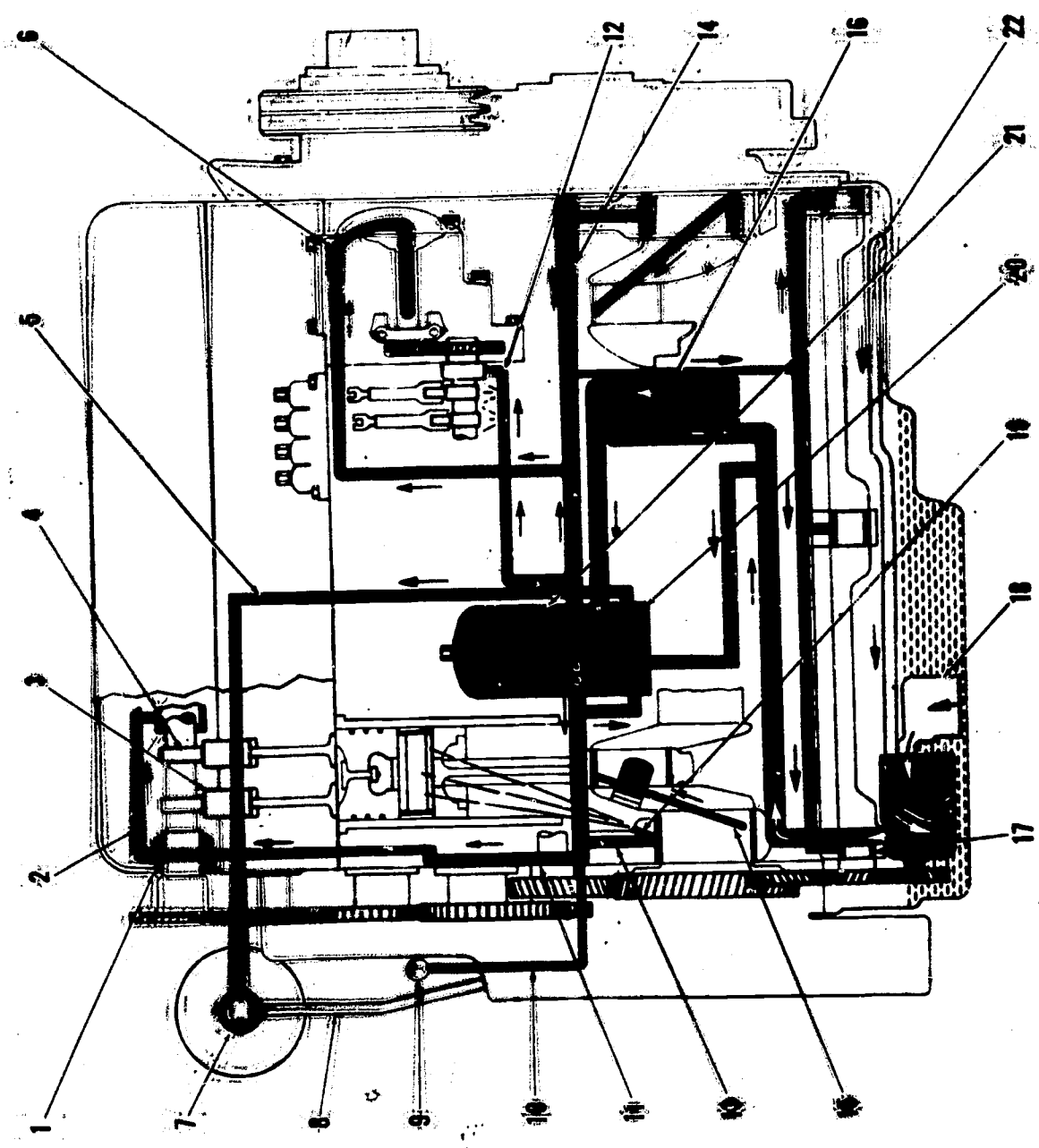

- 1-Crankshaft rear bearing.
- 2-Common oil manifold.
- 3-Camshaft bearing.
- 4-Camshaft cam lobe.
- 5-Turbocharger oil supply line.
- 6-Passage in governor housing.

- FLOW OF LUBRICATING OIL (Schematic)**
- 7-Turbocharger bearing.
 - 8-Turbocharger oil return line.
 - 9-Oil pressure gauge.
 - 10-Line from oil manifold to gauge.
 - 11-Tube supplying lubricant to valve mechanism.

- 12-Fuel injection pump housing oil manifold.
- 13-Passage in block to crankshaft bearing.
- 14-Oil distribution manifold.
- 15-Draining passage in crankcase.
- 16-Scavenge tube.
- 17-Engine oil cooler, or strainer.
- 18-Balancer shaft rear bearing.
- 19-Scavenger oil pump.
- 20-Pressure in oil system.
- 21-Pressure in oil system.
- 22-Scavenger tube.

INSTRUCTOR'S GUIDE

Title of Unit: I -- Caterpillar Lubrication and Components
II -- Learning About Brakes (Part I)

AM 1-26
9/1/66

OBJECTIVES:

1. To acquaint the student with the need for proper lubrication (Functions).
2. To inform the student of Caterpillar's specification for lubricating oil. (Series 3 Lubricant etc.)
3. To teach the student how one failure can lead to another, through lack of proper maintenance of lubrication system.
4. To give trainees information on proper nomenclature concerning lubricating oil, viscosity, service rating, classification, etc.
5. Be sure the student is familiar with the Caterpillar lubrication components, their unique differences from other engines, and special characteristics.
6. The student should have some knowledge of the principle of operation of brakes; also knowledge of the components involved.

LEARNING AIDS suggested:

VUE CELLS:

- AM 1-8 (9) (Scored pistons)
- AM 1-26 (1) (Types of bearing failure)
- AM 1-26 (2) (Piston cooling-oil Jet)
- AM 1-26 (3) (Lubrication system)
- AM 1-26 (4) (Lubrication system)

MODELS:

Any components of the CATERPILLAR Lubrication Sytem or piston, main or connecting rod bearings. Any number of damaged parts to show the results of poor lubrication or lubrication systems neglected, oil change neglected, etc.

NOTE: Instructor may have the student bring a sample of used oil to be used as a demonstration on the use of the Viscometer.

(Get three or four samples).

QUESTIONS FOR DISCUSSION AND GROUP PARTICIPATION:

1. Why is the type and grade of lubricating oil used in diesel engines so important?
2. What effect will excessive wear have on lubricating oil?
3. Why is piston cooling so important in the CAT 824 engine?
4. How is lubrication of piston, rings and cylinder walls accomplished and controlled?
5. What is the purpose of the lubrication filter? What could happen to an engine if the lubrication filter were neglected?
6. Why is it important to periodically check the crankcase oil level?
7. How are impurities that settle in the crankcase removed?
8. How would viscosity be affected by unburned fuel leaking by the piston rings into the crankcase?
9. What are some of the best indicators that the lubrication system needs attention?
10. How is the turbocharger lubricated immediately after starting, and after the engine has been running for some time? Why?
11. What is meant by the following API and SAE, in relation to engines and lubrication?