

R E P O R T R E S U M E S

ED 021 096

VT 005 679

AUTOMOTIVE DIESEL MAINTENANCE 1. UNIT XXV, I--CATERPILLAR
DIESEL ENGINE COOLING SYSTEM D-8 AND 824 MODELS, II--TIRES
AND TIRE HARDWARE.

HUMAN ENGINEERING INSTITUTE, CLEVELAND, OHIO

REPORT NUMBER AM-1-25

PUB DATE 16 SEP 66

MINNESOTA STATE DEPT. OF EDUCATION, ST. PAUL

EDRS PRICE MF-\$0.25 HC-\$1.40 33P.

DESCRIPTORS- *STUDY GUIDES, *TEACHING GUIDES, *TRADE AND
INDUSTRIAL EDUCATION, *AUTO MECHANICS (OCCUPATION), *DIESEL
ENGINES, ADULT VOCATIONAL EDUCATION, TRANSPARENCIES,
PROGRAMED MATERIALS, INDIVIDUAL INSTRUCTION, INSTRUCTIONAL
FILMS, PROGRAMED INSTRUCTION, MOTOR VEHICLES, EQUIPMENT
MANINTENANCE,

THIS MODULE OF A 30-MODULE COURSE IS DESIGNED TO DEVELOP
AN UNDERSTANDING OF THE OPERATION AND MAINTENANCE OF THE
DIESEL ENGINE COOLING SYSTEM AND TO PROVIDE A DESCRIPTION OF
HEAVY TIRES AND WHEELS USED ON DIESEL POWERED VEHICLES.
TOPICS ARE (1) THEORY OF THE COOLING SYSTEM, (2) COOLING
SYSTEM COMPONENTS, (3) MAINTENANCE TIPS (COOLING SYSTEM), (4)
GENERAL DESCRIPTION (TIRES), (5) LIQUID FILLED TIRES, (6)
TIRE MAINTENANCE, AND (7) PROLONGING TIRE LIFE. THE MODULE
CONSISTS OF A SELF-INSTRUCTIONAL BRANCH PROGRAMED TRAINING
FILM "CATERPILLAR DIESEL ENGINE COOLING SYSTEM" AND OTHER
MATERIALS. SEE VT 005 655 FOR FURTHER INFORMATION. MODULES IN
THIS SERIES ARE AVAILABLE AS VT 005 655 - VT 005 684. MODULES
FOR "AUTOMOTIVE DIESEL MAINTENANCE 2" ARE AVAILABLE AS VT 005
685 - VT 005 709. THE 2-YEAR PROGRAM OUTLINE FOR "AUTOMOTIVE
DIESEL MAINTENANCE 1 AND 2" IS AVAILABLE AS VT 006 006. THE
TEXT MATERIAL, TRANSPARENCIES, PROGRAMED TRAINING FILM, AND
THE ELECTRONIC TUTOR MAY BE RENTED (FOR \$1.75 PER WEEK) OR
PURCHASED FROM THE HUMAN ENGINEERING INSTITUTE, HEADQUARTERS
AND DEVELOPMENT CENTER, 341 CARNEGIE AVENUE, CLEVELAND, OHIO
44115. (HC)

STUDY AND READING MATERIALS

AUTOMOTIVE DIESEL 1 MAINTENANCE

U.S. DEPARTMENT OF HEALTH, EDUCATION & WELFARE
OFFICE OF EDUCATION

THIS DOCUMENT HAS BEEN REPRODUCED EXACTLY AS RECEIVED FROM THE
PERSON OR ORGANIZATION ORIGINATING IT. POINTS OF VIEW OR OPINIONS
STATED DO NOT NECESSARILY REPRESENT OFFICIAL OFFICE OF EDUCATION
POSITION OR POLICY

ED 021 096

- I -- CATERPILLAR DIESEL ENGINE COOLING SYSTEM D-8 AND 824 MODELS
- II -- TIRES AND TIRE HARDWARE

UNIT XXV

PART I

SECTION A

THEORY OF THE COOLING SYSTEM

SECTION B

COOLING SYSTEM COMPONENTS

SECTION C

MAINTENANCE TIPS

PART II

SECTION A

GENERAL DESCRIPTION

SECTION B

LIQUID FILLED TIRES

SECTION C

TIRE MAINTENANCE

SECTION D

PROLONGING TIRE LIFE

AM 1-25
9/16/66

Human Engineering Institute - Minn. State Dept. of Ed.
Vocational Education

HUMAN ENGINEERING INSTITUTE

VT005879

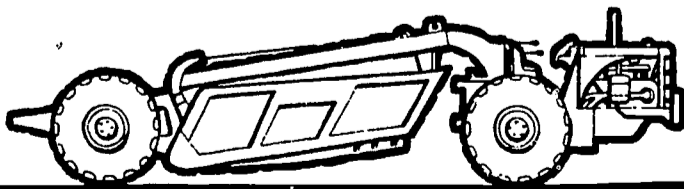
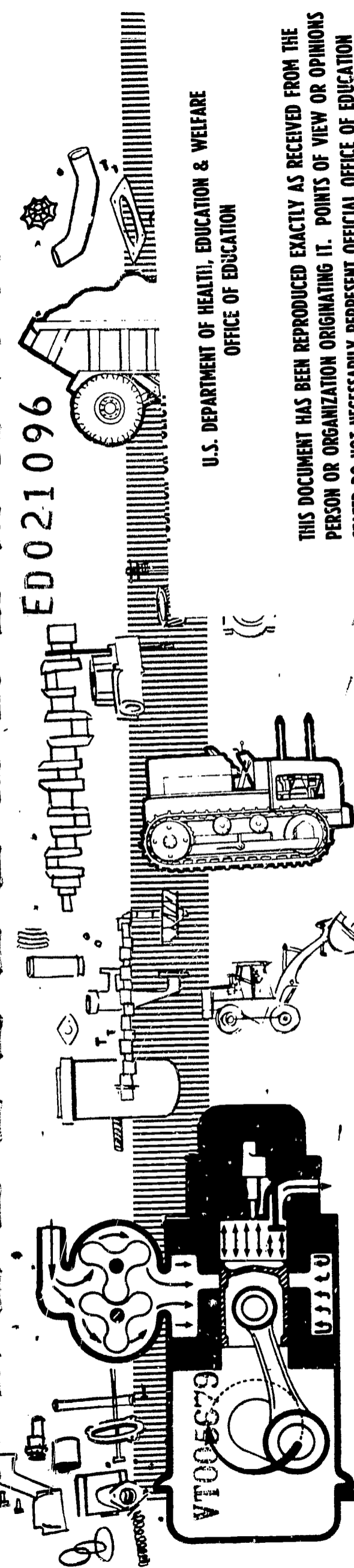

PART I -- CATERPILLAR DIESEL ENGINE COOLING SYSTEM, D-8 AND 824 MODELS

SECTION A -- THEORY OF THE COOLING SYSTEM

Diesel engines, like all other internal combustion engines, convert fuel into mechanical energy. In the conversion process, fuel is burned and heat is generated. Approximately one-third of the potential heat of a given fuel is converted into usable work; the other two-thirds are lost through the exhaust, through the cooling system or radiated from the engine itself.

If no provision were made for cooling the engine, the intense heat of combustion would raise the temperature to a point where lubricating oil would burn, and the moving parts of the engine would seize.

Basically, the radiator type cooling system consists of a circulating pump, passages in the cylinder block and head, water temperature regulators and a radiator. Heat from the coolant is transferred into the air that is pulled or pushed through the radiator by a fan.

FLOW OF COOLANT -- Let's follow the flow of coolant through the system. Coolant is delivered from the bottom tank of the radiator to the inlet side of the water pump. The water pump does a tremendous amount of work. On a D8 Tractor the pump may move as much as 7,500 gallons per hour; on the smaller machines, a pump may circulate between 2,400 and 3,600 gallons per hour.

Coolant is delivered into the cylinder block and oil cooler under slight pressure. It flows upward and around the cylinder liners, through the water directors and into the cylinder head. Water directors in the cylinder head insure that the hotter spots on the engine, such as exhaust valve seats and the precombustion chambers are properly cooled. Water is directed out one side of the water directors very much as it is in the Cummins and GM engines.

From the cylinder head, coolant flows through the water manifold to the temperature regulators located at the forward end of the manifold. Water temperature regulators (sometimes called thermostats) inside the housing are essentially automatic valves which maintain the coolant temperature within the most efficient range for the engine.

Normally, when the engine is first started the coolant temperature is not high enough to open the regulator valves. While the regulator valves remain closed, coolant recirculates through a bypass directly to the pump instead of being cooled in the radiator core. This assures more rapid warm-up of the engine.

When the coolant temperature reaches the operating range, the regulator valves open and allow the coolant to flow to the tank at the top of the radiator, down through the radiator core where it is cooled, and then to the inlet side of the pump for recirculating through the engine. Even with the regulators open, a small amount of coolant flows through the bypass to the inlet side of the water pump.

Cooling systems on CATERPILLAR diesel engines are pressurized; the pressure inside the cooling system is higher than atmospheric pressure. Pressure is maintained by a sealed pressure overflow valve which is located in the radiator top tank or radiator cap.

There are two reasons for pressurizing the cooling system. First, the internal pressure helps force entrapped air to the highest points on the system, where it can be removed. If air bubbles remained within a cylinder block or head, localized hot spots would occur. Second, by pressurizing the cooling system, evaporation loss of coolant is greatly reduced, plus the fact that water boils at a higher temperature under pressure. The valve also prevents loss of coolant on downhill operations when the coolant has a tendency to flow toward the radiator top tank.

As the coolant temperature rises, the pressure in the coolant system increases, due to the expansion of the coolant. When the internal pressure reaches six pounds per square inch, the relief valve in the overflow unit opens to prevent excessive build-up in the system. When the pressure falls below six psi, the relief valve closes.

If the internal pressure drops below atmospheric pressure, as it may when the engine is stopped and cooled, a vacuum-relief valve in the sealed pressure overflow valve opens. This allows air to enter the top tank through the overflow tube and vacuum relief valve. The valve opens when the vacuum of one pound per square inch develops.

In some installations where raw water is abundant, (Marine and Stationary Engines) a heat exchanger is used instead of a radiator to remove heat from the engine coolant. The heat exchanger may be mounted away from the engine. Engine coolant circulates around the tubes of the heat exchanger core. Raw water, which is forced through the heat exchanger tubes removes heat from the engine coolant. An expansion tank, which is comparable to a radiator top tank, provides space for expansion of engine coolant as the coolant temperature rises.

SECTION B -- COOLING SYSTEM COMPONENTS

There is one item of equipment on CATERPILLAR Diesel Engines that is common to the cooling system and engine lubricating system; the oil cooler. Oil coolers are either the air cooled radiator type located in the radiator assembly next to the water radiator core, or they may be the heat exchanger type. In the heat exchanger type, coolant is delivered through the oil cooler under pressure from the discharge side of the water pump.

The cooling system looks simple, and it is simple, but scheduled care and maintenance are required to keep it functioning properly.

First, let's discuss the coolant itself. The condition and type of coolant within the engine determine to a large degree whether or not future cooling problems will arise. Clean water is the first essential, since dirt and other impurities can clog the cooling system. Abrasive particles in the water also can damage the water pump.

Hard water causes scale deposits or formations within the engine. The minerals in the water form a crust over the inside of the water passages. As the formations build up, they restrict the flow of water. Also, because they are good insulators, they can easily cause some parts of the engine to overheat.

Scale deposits (lime) about 1/32 of an inch thick have about the same insulating properties as a piece of steel plate two inches thick. Deposits form most rapidly on the hotter parts of the engine. For all these reasons, it is very important that formation of scale be minimized. An engine cannot be properly cooled with deposits in the water passages.

Adding CATERPILLAR Rust Inhibitor, or any approved inhibitor, to the coolant is the best method of retarding scale formation. CATERPILLAR Rust Inhibitor is a soluble oil that settles in a thin film on all surfaces of the cooling system. It will prevent rust and will retard or prevent scale formation, depending on the water used for filling. The coolant should be at least two percent CATERPILLAR Rust Inhibitor, measured by volume. Follow manufacturers' directions on any other approved brand used.

The amount of lime deposit in an engine cooling system will depend a great deal on how frequently water is added to the cooling system. A teakettle, which is constantly being refilled, best illustrates this point. Note the thickness of the lime deposits on the teakettle in your kitchen.

Even though rust inhibitor has been used, frequent additions of hard water may require that the lime deposits be removed from the system by chemical means.

In cold weather, the cooling system should be protected by the addition of anti-freeze. Anti-freeze such as ethylene glycol (permanent type) base should be used in diesel engines in preference to alcohol, because of its higher boiling point and non-flammable quality.

One important thing to remember about ethylene glycol: the lowest freezing point, approximately sixty five degrees below zero Fahrenheit, is reached with a mixture of thirty percent water and seventy percent ethylene glycol. Adding more ethylene glycol actually raises the freezing point of the solution. Pure commercial ethylene glycol freezes at about ten degrees above zero F.

Permanent anti-freeze has a tendency to seep out through gaskets, joints and hose connections unless they are perfectly sealed. The cylinder head stud nuts, gasket joints and all hose clamps should be checked for tightness before adding anti-freeze to the cooling system.

Improper radiator maintenance is probably the most frequent cause of cooling system overheating. It's virtually impossible to keep dirt and debris from collecting on the radiator core, but frequent cleaning will prevent cooling system difficulties. The dirt can be washed, blown or brushed out, depending upon the most convenient and efficient method for the type of clogging encountered. When washing or blowing dirt out, it's generally more effective to work from the rear of the radiator if the machine has a suction fan.

SECTION C -- MAINTENANCE TIPS

Here is a method that can be used to remove dirt and debris collected in a radiator core. It has been used successfully especially in logging operations. A length of large hose, temporarily fastened to the starting engine exhaust pipe, makes a source of pressure to blow dirt and debris out of the radiator core. While cleaning the radiator, check for bent fins. Fins that are bent may reduce air flow enough that the engine will overheat. The fins can be straightened with a screwdriver or putty knife, but a fin comb makes the job easy and rapid.

Fan belt tension should be checked frequently. Loose fan belts, that slip on the pulleys, will decrease fan speed; engine overheating can result. If fan belts are too tight, the pulley bearings may be damaged.

A practical rule of thumb for fan belt tension: the adjustment is approximately correct if you can push the belt inward, at a point midway between the pulleys, an amount equal to the belt thickness.

Another point to check is the sealed pressure overflow unit. Cleaning the unit is necessary to remove the lime deposits and other accumulations that might hold the valve in the open position and make it ineffective. The unit should be removed and cleaned about twice a year.

In marine and stationary engines that are equipped with heat exchangers and cooling towers there will be zinc rods, plates or plugs located throughout the raw water system. The zinc plugs, rods etc, localize any electrolytic action that is set up. At intervals, given in the Operation and Maintenance Instructions manuals, these plugs should be inspected. Don't be deceived by their outward appearance; tap the plug lightly with a screw driver or small hammer. If they crack or crumble, new zinc elements should be installed. If they prove to be sound but are corroded, clean them by scraping away the corrosion.

In order to retain cooling efficiency, the tubes of the heat exchanger should be cleaned periodically. Don't overlook fan and water pump bearing lubrication, and be careful to keep grease off the belts. A grease soaked belt can't transmit the power necessary to turn the fan and pump.

Whenever it is necessary to drain the cooling system, particularly when flushing it or when shutting down without anti-freeze in the system during cold weather, be sure that you have opened all of the drain cocks in the radiator and cylinder block. Otherwise, coolant may be trapped within the system. When water freezes, its volume expands about nine percent and the result can be expensive.

Before shutting down an engine that has been heavily loaded, let it idle without load for about five minutes. This will allow the coolant time to carry excess heat from the engine and equalize temperatures throughout the engine.

Never add cold water to a hot cooling system with the engine stopped. The cold water may cause the engine parts to contract suddenly, and the result can be a cracked cylinder head. If it is necessary to add water to a system that is low on coolant, keep the engine running and add water very slowly. The added water will circulate through the engine and reach operating temperature without cooling any particular part more than others.

If recommended procedures are followed, difficulties with the cooling system will be held to a minimum. However, let's look at the methodical approach for correcting the most common cooling system overheating problems.

First, make sure there is sufficient coolant in the system. Then, confirm that the engine is actually overheating, by using a reliable thermometer in the top tank of the radiator. The water temperature indicator could be inaccurate, and the engine may not be overheating at all.

Remove leaves, mud or debris which have accumulated on the outside of the radiator core. If necessary, remove the radiator guards to thoroughly clean the core.

Next, check the fan belt for the proper adjustment and the pulleys for wear. Improper adjustment or dirt and grease on the fan belt can cause excessive wear and slippage resulting in overheating.

Check the temperature of the air going into the radiator; be especially careful in stationary engine installations. If the surrounding air temperature is too high and the load on the engine approaches full load, even a cooling system in perfect condition may overheat.

If the engine still overheats, check the fan. See that the blades are in good condition and that the angle of blades has not been changed by having struck some object. Sand may have worn away the tips of the fan, or the fan may have been installed in the reverse position. Check all hose connections of the cooling system. The hoses may appear to be in good condition on the outside but may have deteriorated on the inside to the extent that they restrict the flow of coolant.

Next, remove the water temperature regulators and check their opening temperatures. If the regulators are found to be satisfactory, reinstall them before continuing with the test of the cooling system. Never operate the engine unless the regulators are installed. Remember that the regulators keep the engine temperature in its most efficient range. Removing the regulators may appear to cure the overheating, but the operating temperature may drop so low that rust and sludge can form in the crankcase and cause extensive damage.

Air inside the cooling system can cause overheating. Air leakage can be determined by a simple but effective check known as the "bottle test". After the engine is warmed up, stop the engine, making sure the radiator

cap is tight. Put a rubber hose over the overflow tube and the other end in a bottle filled with water. Invert the bottle (turn upside down) in a bucket of water and run the engine at high idle speed. If water in the bottle is displaced by air, try tightening the cylinder head studs and precombustion chambers.

If this doesn't do the job, check the cylinder head and precombustion chamber gaskets for damage.

Next, check the water pump for a loose or badly corroded impeller. Also inspect the seal and check for a worn or broken shaft. If the overheating problem still exists, inspect the water passages for sediment or scale deposits. These deposits may restrict the flow of coolant or retard the transfer of heat from the cylinder block and head to the coolant. The condition of the precombustion chamber surfaces, which come in contact with the coolant, give a good indication of the deposit built-up in the hotter areas of the engine.

There are other conditions which a well functioning system will not adequately cool the engine. One is operating a machine under a continuous overload that lugs the engine down below its rated speed. As a correction, do not continuously overload the engine.

The altitude at which the engine is operating should also be considered when overheating is encountered. The available horsepower of the engine decreases as the altitude increases, and the engine may be overloaded. Also, the boiling point of water is lower at high altitudes than at sea level. This causes more rapid evaporation, and the coolant loss may be the cause of overheating.

One point should be emphasized in trying to find the cause of engine overheating; that is, check the cooling system first. There is little chance that the fuel system, lubrication system or other parts of the engine are the cause of the engine overheating. However, if something is wrong in

the other systems, there will generally be other symptoms besides engine overheating. Remember, check the cooling system first. If the proper coolant is used and the scheduled maintenance procedures recommended are followed, cooling system difficulties can be minimized or eliminated.

PART II -- TIRES AND TIRE HARDWARE

SECTION A -- GENERAL DESCRIPTION

Off-the-highway tires are rugged tires designed to operate under conditions that would make short work of highway type tires. Moreover, they usually carry greater loads than those carried by highway type tires. However, such loads are permissible only because of the slower speed at which off-the-highway equipment operates. If these tires were operated at speeds greater than their maximum rated speed, the increased rate of sidewall flexing would generate excessive heat within the tire. Indeed, if sufficient rotational speed of these tires were attained, their temperature would reach, or even exceed, their vulcanizing temperature. If this point is reached the tire will, of course, fail.

Two types of tires are used on these vehicles: tubeless tires and tires with tubes. The tubeless tire and rim assembly is illustrated in Figure 1.

The tire, tube and rim assembly is illustrated in Figure 2.

TIRE CONSTRUCTION -- The design and construction of both the conventional type, and the tubeless type tires are practically identical. The main difference is the manner in which the air is contained within the tire and rim assembly.. The conventional type tire has the familiar innertube which is inflated with air to support the load. The tubeless tire uses no innertube. The tire and rim assembly make up the airtight

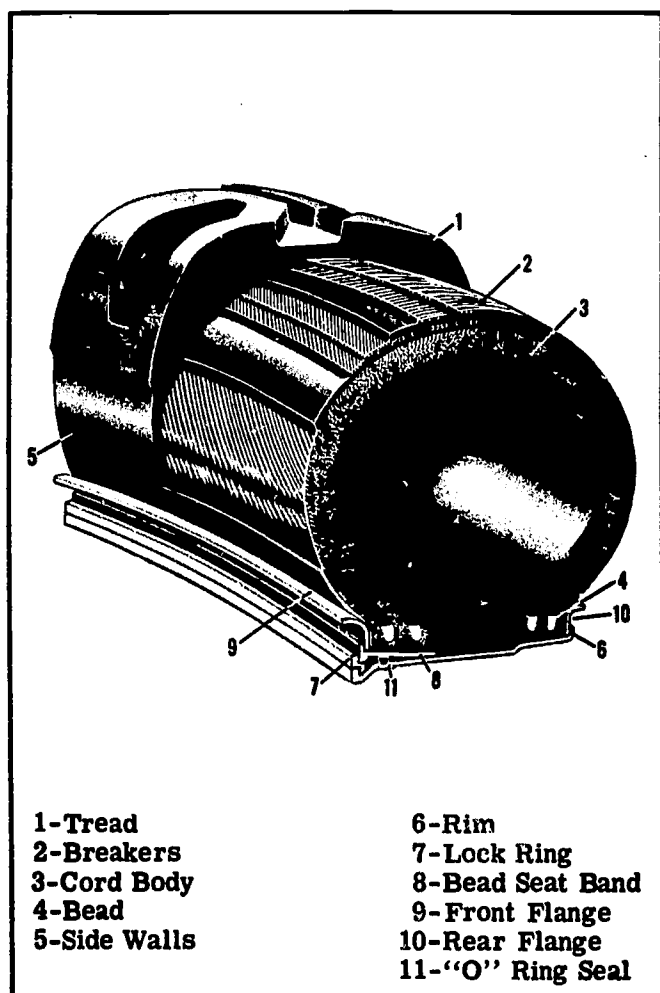

Fig. 1 Tubeless tire and rim assembly

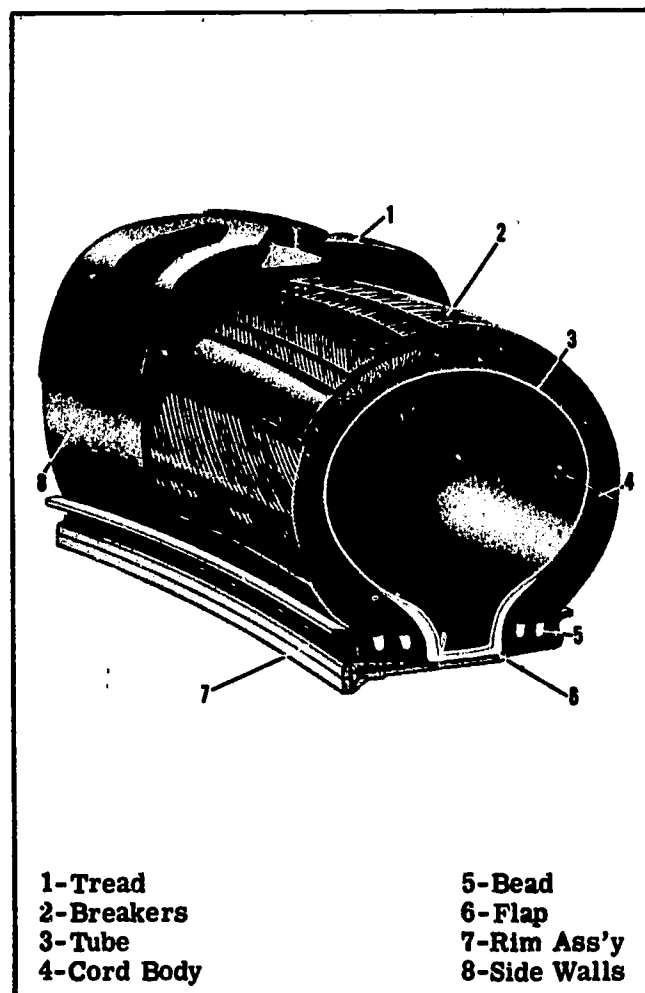

Fig. 2 Tire, tube and rim assembly.

chamber that supports the load. A rubber "O" ring is used with this assembly to make an air seal between the rim parts.

Tires consist of a bead, carcass or cord body, breakers, sidewalls, and tread.

The bead is the foundation of the tire. It is made from high tensile strength steel wire insulated with rubber and wrapped with fabric. A strong bead is necessary on off-the-highway tires to support the tire on the rim under the strain of heavy loads and uneven terrain.

The tire carcass or cord body is composed of numerous layers of rubber-impregnated fabric called plies. These plies contain the inflation pressure, support the load and cushion the shock of impacts.

The breakers are layers of fabric and rubber located between the tread and body of the tire. These layers help to distribute road shocks and thus protect the cord body.

Sidewalls of the tire are covered with a protective coating of flexible rubber. This covering protects the tire carcass and is designed to flex and bend as the tire rotates.

The tire tread, as the name implies, is part of the tire that provides the traction between the tire body and the ground. It is a long wearing surface that protects the tire body from being cut or chipped.

SECTION B -- LIQUID FILLED TIRES

It has been shown that by increasing the load on the drive axle of a vehicle of sufficient power, its tractive ability is also increased. A simple method of adding weight to the drive wheels of load-carrying vehicles consists of partial filling of the tires with liquid instead of air. This method of replacing 75% of the contained air with a solution of calcium chloride is selected for the following reasons; the additional weight (up to 50%) that can be gained over the weight of plain water is better from the traction standpoint; it is not harmful to rubber, and it is a plentiful low-cost compound for anti-freeze use.

Filling tires 100 percent with liquid is NOT recommended, as variations in pressure which occur with large variations in tire loads may cause internal pressure increases and tire stresses too great for safety and satisfactory tire service.

Tubes used in tires filled with calcium-chloride solution must be equipped with special sealed-in-base valves which prevent separation of the rubber valve base and the valve metal.

Liquid filling also is recommended for use with tubeless tires. For added protection against rim corrosion, however, a coating of Rustoleum should be applied to the part of the rim that comes into contact with the solution.

A special corrosion-proof gage should be used for checking the pressures of liquid filled tires. Moreover, the valve should always be in the lowest position; otherwise, variations in pressure readings will be noted due to the difference in the height of the static head.

The amount of water and calcium chloride needed for filling earthmover tires 75% full of liquid can be easily calculated. The formulas for finding the quantity of water and calcium for any tire, if the volume in cubic inches is known, are:

$\frac{3}{4}$ tire vol. in cu. in. divided by 231 = gals of water needed
gals. of water x 8.3 = pounds of water added
gals. of water x 3.5 = pounds of calcium chloride needed

Thus, 3.5 pounds of calcium chloride per gallon of water will provide protection against freezing to 30° below zero.

It must be remembered, of course, that liquid-filled tires void the vehicle weight specifications given in the manufacturer's manual.

SECTION C -- TIRE MAINTENANCE

TIRE REPAIRS -- Prompt repair of tire injuries, as soon as discovered, will prevent small injuries from enlarging and causing tire failure.

Minor cuts, snags or punctures should be repaired as soon as they are found. Skive with a sharp pointed knife around any cut in the tire tread area that is of sufficient depth or shape to hold pebbles or dirt. The angle of the skive should be no more than enough to expel all foreign material and should extend no deeper than the breaker. The skive should go to the bottom of the hole, and the tire can be allowed to continue in service. If the cut extends deeper into the tire carcass, the tire should be removed for repair, see Figure 3.



Fig. 3 Skived cut reveals imbedded stone.

Irregular shaped punctures or cuts less than 1/2" can be repaired with a plug and hot patch. Insert a repair plug into the hole to keep out moisture and to back up the hot patch. Trim the plug off flush with the inside of the casing, buff, and apply the hot patch according to the instructions supplied with the hot patch equipment.

Punctures 1/2" or larger, large cuts or bruise breaks will require sectional or reinforced vulcanized repair. The same procedures for making repairs as those used for conventional tires should be followed

for tubeless tires. However, be sure to cover the repair patch with a layer of cushion gum after application to the tubeless tire to insure an air-tight repair. Any cords of the inside ply that are exposed in buffing and are not covered with repair patch must be coated with cushion gum to prevent air leakage into the carcass plies.

SECTION D -- PROLONGING TIRE LIFE

To get maximum service from off-the-highway tires, a few common sense precautions should be followed:

MAINTAIN CORRECT INFLATION -- The most common cause of tire damage is improper inflation. Both over inflation and under inflation are detrimental to tire life. Tire pressure should be checked daily, preferably before the vehicle is put in operation. The valve cores should be checked for leaks. Keep in mind that valve cores are delicate mechanisms which wear out in service. They should be replaced when they become worn. Each tire should be equipped with a valve cap, to prevent dirt from damaging the valve core and causing air leakage.

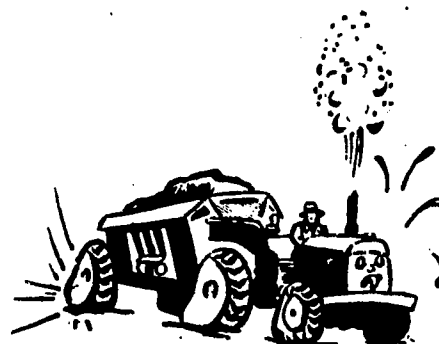

MAINTAIN GOOD HAUL ROADS -- Because haul roads are considered as temporary roads, they frequently are neglected. However, these roads should receive maintenance equal to or superior to that given established highways. The better the haul road, the longer the tire and vehicle life of off-the-highway equipment will be. Although it takes time and effort to maintain good haul roads, the cost of tires, vehicle



repair, and delay resulting from breakdowns caused by poor haul roads is many times greater.

INSPECT TIRES REGULARLY -- A systematic plan for tire inspection will more than pay for itself in lowered tire costs per hour of operation. All tires should be checked regularly for cuts, bruises, fabric breaks, rocks lodged between duals, excessive or uneven wear, imbedded foreign matter, and any other damage which can be repaired.

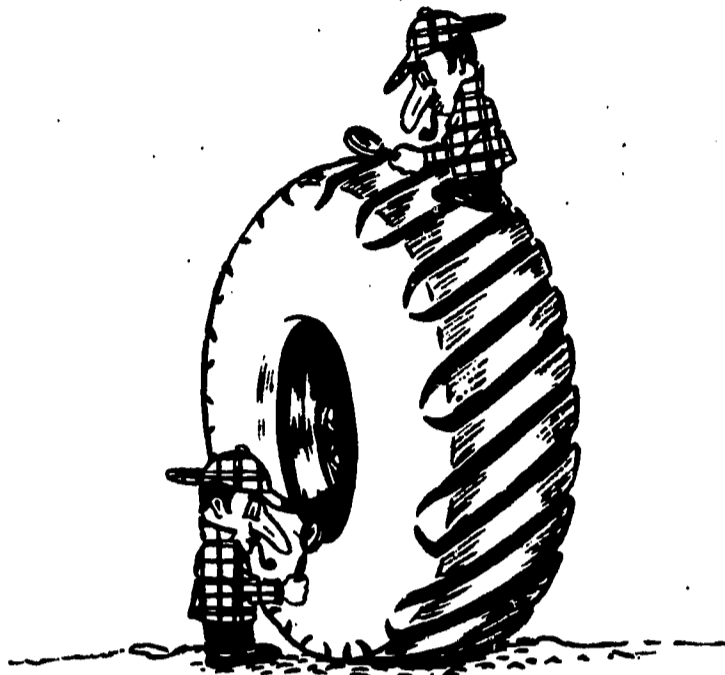

A considerable increase in tire service can be realized if tire injuries are repaired before they have progressed to the irreparable state. The rim clamping stud nuts should be checked periodically and tightened to the recommended torque setting, to avoid tire and rim slippage on the wheel.

PREVENT OVERLOADING -- Off-the-highway vehicles are designed to carry a maximum allowable payload. Excessive loading will overstress both the vehicle and tires and will shorten the life of both.



AVOID TIRE CONTACT WITH OIL -- PREVENT TIRE CONTACT WITH PETROLEUM PRODUCTS. Rubber that is exposed to oil, gasoline, or grease becomes soft and spongy, and deteriorates rapidly. Always avoid driving vehicles equipped with rubber tires through puddles of gasoline, fuel oil, lubricating oil or grease. Never let a tire stand in an oil or grease spot overnight.

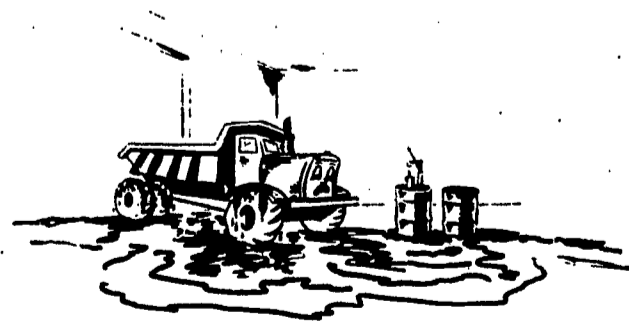

MATCH ALL DUALS -- When vehicles are equipped with dual tires that are of unequal circumference, the larger tire, obviously, carries the greater load and is subjected to greater wear and punishment. This practice can result in the failure of both tires, as a sudden failure of the larger tire will immediately overload the smaller tire. To eliminate this possibility, there should be a difference of not more than 1/2" in diameter, or 1 1/2" in circumference between the two duals. Circumferential measurements with a steel tape is the most accurate method for matching dual tires. However, a segment caliper, straight edge caliper, or carpenter's square can also be used for this purpose.

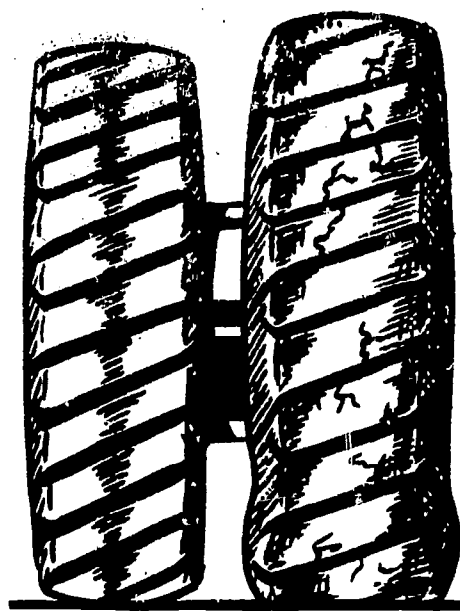

STORE TIRES PROPERLY -- The best of care given tires in service by operators and maintenance personnel can be completely nullified by careless storage. Time is not the only contributing factor to the deterioration of rubber products. Therefore, tires that are to be stored must be protected from light, heat, oils, dirt, moisture and ozone. Stored tires should be carefully covered with a tarpaulin, or some other suitable material such as opaque plastic sheeting, to prevent contact with the contaminants listed above.

TIRE HANDLING -- The beads of tubeless tires must be protected from damage or a faulty air seal will result. Do not use hooks, cables, or chains in contact with the tire beads when lifting these tires. If forklift trucks are used for handling they should be equipped with broad, well-rounded arms to distribute the load and prevent damage to the tire bead. When handling tires with the fork truck do not scrape the fork across the bead.

This has been a brief description of tires and their maintenance. Mounting and de-mounting of tires of this size and weight can be dangerous, and extreme care must be exercised when doing it. Consult the maintenance manual for proper procedure and tools.

AM 1-25D
9/1/66

CATERPILLAR DIESEL ENGINE COOLING SYSTEM

**Human Engineering
Institute**

**Minn. State Dept. of Ed.
Vocational Education**

Press A

Check to see that timer is OFF.

This lesson is designed to supplement Unit No. AM 1-25 class text, Maintaining the Cooling System -- CATERPILLAR diesel Engine.

There may be some repetition of information covered in previous units. In some sections the repetition will be intentional since all cooling systems have something in common: to remove heat from the engine.

Press A

2

Diesel engines, like all other engines, convert fuel into mechanical energy. In the conversion process, fuel is burned and heat is generated. The approximate heat from the total potential that is converted to usable work is _____.

- 2 A. one-half
3 B. two-thirds
4 C. one-third

The text states that in the conversion process (fuel into mechanical energy) approximately one-third of the potential heat of a given fuel is converted into usable work; the other two-thirds are lost through the exhaust, or the cooling system, or radiated from the engine itself.

Press A

4

OK. If no provision was made for cooling the engine, the intense heat of combustion would raise the temperature to the point where lubricating oil would burn, and one of the three following things would happen to the moving parts in the engine.

- 5 A. Service life would be shortened.
5 B. Demand constant attention.
6 C. Moving parts would seize.

If no provisions were made for cooling the engine, the moving parts of the engine would soon seize from the lack of lubrication. The engine would get so hot it would cause the lubricating oil to thin out or burn. As a result you would get seizure of moving parts.

Press A

6

OK. Basically, the radiator type cooling system consists of a circulating pump, passages in the cylinder block and head, water temperature regulators and a radiator.

Heat is transferred to the air from the coolant by what method?

- 8 A. Radiation
7 B. Circulation
7 C. Absorption

No, you are only partially right, the correct answer is: heat is transferred to the air from the coolant by the process of (as the name implies) radiation.

Press A

8

OK. Let's follow the flow of coolant through the system. Coolant is delivered from the (1) _____ tank of the radiator to the inlet side of the (2) _____.

- 9 A. (1) bottom (2) water jacket
10 B. (1) bottom (2) water pump
9 C. (1) top (2) engine block

9

No, the flow of coolant starts from the bottom of the tank and from there it goes to the suction side of the water pump, or inlet side if you prefer. It goes from the pump to the engine water passages throughout the block, back to the top radiator tank, down through the core and repeats the route again and again.

Press A 10

OK. On a D8 Caterpillar engine the circulating water pump may move as much as 7,500 gallons per hour; while on some of the smaller CAT machines, a pump may circulate between _____

- 11 A. 4,500 and 5,000 gallons per hour
- 12 B. 2,400 and 3,600 gallons per hour
- 11 C. 1,500 and 2,000 gallons per hour

10

11

No, the correct answer is 2,400 to 3,600 gallons per hour.

Press A 12

OK. What provision (if any) is made for directing the coolant to the hot spots in the engine, exhaust valve seat area etc.?

- 13 A. The natural flow of the coolant through the engine block.
- 13 B. Convection current causes the hot water to be displaced by cold water, thus cooling the hot spots in the engine.
- 14 C. Water directors are installed in the cylinder head to direct the coolant (water) toward the exhaust valve seats etc.

12

13

No, the natural flow of the coolant is not enough to cool the hot spots (exhaust valve seat area etc.). Convection current is what takes place in an open pan of water when heat is applied, but is not sufficient to cool the hot spots such as the exhaust valve seat area.

The correct answer is: water directors are installed in the cylinder heads to direct the coolant toward the hot spots.

Press A 14

OK. Water is directed out one side of the water directors very much like Cummins and GM engines. From the cylinder head, coolant flows through the water manifold to the _____

- 16 A. temperature regulators
- B. pressure regulators

XC 15

(The correct answer must be chosen before advancing to the next frame.)

14

15

You have missed one or more answers in this section and should have the opportunity to go back for a review. Read the questions over carefully and take your time in selecting an answer.

Press A 2

OK. Temperature regulator (sometimes called thermostat) is the correct answer.

Normally, when the engine is cold and the temperature regulator valves are closed, what provision is made for the coolant to circulate through the engine block?

- 18 A. The coolant by-pass allows the coolant to circulate throughout the engine block but not through the radiator, until the temperature reaches a predetermined value.
- 17 B. The temperature regulators have small holes in the valve body that allow a small amount of coolant to recirculate.

16

17

No. When the engine coolant is cold and the temperature regulator valves are closed the coolant circulates through the by-pass directly to the pump instead of being cooled in the radiator core. This assures more rapid warm-up of the engine.

Press A 18

Cooling systems on Caterpillar engines are pressurized. There are several reasons for pressurizing the system:

- 17 A. The engine may operate with a higher coolant temperature without boiling over through the pressure cap, and water boils at a higher temperature under pressure.
- 19 B. Internal pressure helps force entrapped air to the highest point where it can be removed, and prevents the loss of coolant on downhill operations where the coolant tends to flow toward the top tank.
- 20 C. Both "A" and "B" are correct.

19

No, there are several reasons for having a pressurized cooling system in CAT and many other make engines as well. "A" and "B" from the previous answer are just a few of the many reasons.

Press A 20

20

OK. As the coolant temperature rises, from a cold condition after having been stopped for some time, the coolant pressure also rises, resulting in expansion which would cause damage to the cooling system if it were not for one thing:

- 21 A. the pressure regulator
- 21 B. the by-pass valve
- 22 C. the relief valve in the overflow unit

21

No; as the coolant temperature rises, the pressure in the coolant system increases, due to the expansion of the coolant. When the internal pressure reaches 8 to 12 pounds per square inch, the relief valve in the overflow unit opens to prevent excessive pressure build-up in the system.

Press A 22

22

OK. If the internal pressure drops below atmospheric pressure, what prevents the radiator core or some other weak section of the cooling system from collapsing?

- 23 A. The system is built strong enough to withstand any vacuum, (under normal operating conditions) that the system would be subjected to.
- 24 B. A vacuum relief valve in the sealed pressure overflow valve.
- 23 C. The pressure would automatically equalize and there is no need for any special valves etc.

23

No. If the internal pressure drops below atmospheric pressure, as it may when the engine is stopped and cooled, a vacuum relief valve in the sealed pressure overflow valve opens. This allows the air to enter the top tank through the overflow tube and vacuum relief valve. The valve opens when a vacuum of one pound per square inch develops.

Press A 24

24

OK. In marine and/or stationary engines where heat exchangers are used, what provision is made for expansion of the engine coolant?

- 25 A. Since raw water flows freely through the heat exchanger, there is little or no need for considering coolant expansion.
- 26 B. Marine and stationary engines that use heat exchangers have expansion tanks that serve almost the same purpose as the radiator top tank on mobile equipment engines, plus, the usual relief valve.
- 25 C. Neither are correct.

25

No. Engines that use heat exchangers instead of radiators are equipped with expansion tanks, comparable to radiator top tanks, which provide space for expansion of engine coolant as the coolant temperature rises.

Press A 26

OK. There is one item of equipment on Caterpillar engines that is common to the cooling system and the engine lubricating system. _____

- 28 A. The oil cooler
— B. The circulating water pump

XC 27

(The correct answer must be selected before advancing to the next frame.)

26

27

You have missed one or more answers in this section and should go back for a review. Take your time, read the questions carefully and consider your answer before making the selection.

Press A 16

OK. Oil coolers are either the air cooled radiator type located in the radiator assembly next to the water radiator core, or they may be the heat exchanger type. In the heat exchanger type, coolant is delivered through the oil cooler by _____

- 30 A. pressure from the discharge side of the water pump.
29 B. suction from the water pump drawing coolant through the oil cooler.
29 C. convection current causing the hot water to be displaced by cold water, thus carrying away the heat from the oil cooler.

28

29

No, in the heat exchanger type of oil cooler, the coolant is delivered through the cooler under pressure from the discharge side of the water pump.

Press A 30

Caterpillar cooling systems look simple, and are simple, but scheduled care and maintenance are required to keep them functioning properly. The condition and the type of coolant in the engine determine to a large degree whether or not future cooling problems will arise.

What is considered to be the first essential in any cooling system?

- 31 A. The proper mixture of anti-freeze and water.
31 B. The proper mixture of rust inhibitor and water.
32 C. Clean coolant.

30

31

No. The cooling system like other systems, fuel, lubrication, air etc., must be kept clean. Clean water is the first essential, since dirt and other impurities can clog the cooling system. Abrasive particles in the water also can damage the water pump. The anti-freeze usually contains a rust inhibitor but never the less anti-freeze and water should be mixed properly, (correct amounts of each).

Press A 32

OK. Yes all the systems must be kept clean.

Hard water causes scale deposits or formations within the engine. The minerals in the water form a crust over the inside of the water passages.

The insulating ability of scale deposits (lime) about 1/32 of an inch thick has about the same heat transfer properties as a piece of steel plate _____ thick.

- 34 A. 2 inches
33 B. 12 inches
33 C. 2 feet

32

33

No, the Unit states: The insulating ability of scale deposits (lime) about 1/32 of an inch thick has about the same heat transfer properties as a piece of steel plate 2 inches thick.

Press A 34

The manufacturer of Caterpillar engines has a definite means of retarding the formation of scale deposits.

- 35 A. Use only pure distilled water when the engine is new.
- 36 B. Add Caterpillar rust inhibitor to the cooling system.
- 35 C. Fill the cooling system with 100% anti-freeze.

35

36

No, the use of pure distilled water would minimize the formation of scale, but it would be impractical and would not eliminate the formation of scale deposits.

The manufacturers of anti-freeze and the Caterpillar Company will recommend a solution of water and anti-freeze be added to the cooling system, but not 100% anti-freeze.

The correct answer is: add Caterpillar rust inhibitor or any other approved brand, to the cooling system to retard or prevent scale formation.

36 Press A

OK. In cold weather, the cooling system should be protected by the addition of anti-freeze. Anti-freeze such as ethylene glycol (permanent type) base should be used in diesel engines in preference to alcohol, because _____

- 37 A. permanent type is cheaper over the long run.
- 38 B. permanent type anti-freeze has a higher boiling point and is non-flammable.
- 37 C. permanent type anti-freeze is recommended by the Caterpillar Tractor Company.

37

38

No. The most important reason a permanent type anti-freeze is used is not only because the manufacturer recommends it, but because it has a higher boiling point and is non-flammable.

Read the questions carefully, consider each of the answers before you make your selection.

Press A 38

OK. One important thing to remember about ethylene glycol base anti-freeze: the lowest freezing point, approximately sixty five degrees below zero, is reached with a mixture of thirty percent water and seventy percent ethylene glycol. Adding more anti-freeze actually raises the freezing point of the solution.

Pure commercial ethylene glycol freezes at about _____

- 39 A. ten degrees below zero
- 40 B. ten degrees above zero
- 39 C. sixty five degrees below zero

39

40

No. Pure commercial ethylene glycol freezes at about ten degrees above zero.

Press A 40

OK. Permanent anti-freeze has a tendency to seep out through gaskets, joints and hose connections unless they are perfectly sealed. What is the best method of insuring the system is sealed and ready for the addition of anti-freeze to the cooling system?

- 41 A. Add a sealing compound to the cooling system.
- 41 B. Add about 15 to 25 percent torque to all belts, nuts, and fittings to insure tightness.
- 42 C. The cylinder head stud nuts, gasket joints and all hose clamps should be checked for tightness before adding anti-freeze to the cooling system.

41

No, the addition of some sealing compounds will clog water passages and restrict the flow of coolant, causing the system to overheat. Once the cylinder head, bolts and nuts have been torqued never add to the torque values recommended in the manufacturer's specifications.

Press A 42

OK. Improper radiator maintenance probably is the most frequent cause of cooling system overheating. It is virtually impossible to keep dirt and debris from collecting on the core, but frequent cleaning will prevent cooling system difficulties. The dirt can be removed by

42

- 43 A. blowing from the rear of the core by high pressure air.
- 44 B. washing with a soap and water solution and a soft brush, using caution not to bend the fins, then blowing dry with relatively low pressure air.
- 43 C. removing the core from the vehicle and dipping it in a cleaning solution.

43

No: never use high pressure air to clean radiator core as damage to the fins will result. It can be cleaned in the vehicle, without removing, if care and caution are exercised.

When washing or blowing the dirt out, it is generally more effective to work from the rear of the radiator if the machine has a suction fan.

Press A 44

OK. Fan belt tension should be checked frequently. Loose fan belts, that slip on pulleys. will decrease fan speed, and (1) . If the fan belts are too tight (2) .

44

- 45 A. (1) belt damage may result
(2) the generator or alternator may come loose
- 45 B. (1) the belt may hit the radiator and cause damage
(2) the belt may break
- 46 C. (1) overheating may result
(2) pulley bearings may be damaged

45

No. Loose fan belts may cause overheating of the engine and too tight fan belts may cause damage to the pulley bearings.

Press A 46

OK. Another point to check is the sealed pressure overflow unit. Cleaning the unit is necessary to

46

- 48 A. remove the lime deposits and other accumulations that might hold the valve in the open position
- 47 B. remove any corrosion that might hold the valve in the closed position.
- 47 C. (neither "A" or "B". the valve is made of a non-corrosive material. and should be removed only to check the opening pressure.)

47

No. Lime deposits will accumulate on the valve and possibly hold it open. It is unlikely that the valve would be held in the closed position.

The service manual states that the unit should be removed and cleaned about twice a year.

Press A 48

OK. The marine and stationary engines that are equipped with heat exchangers will have zinc rods, plates, or plugs located throughout the raw water system. The zinc plugs, rods etc. are to

48

- A. reduce the possibility of static electricity
- 50 B. localize any electrolytic action that is set up by dissimilar (different) metals

XC - 49

(The correct answer must be selected before you can go on to the next frame.)

49

You have missed one or more questions in this section and should go back for a review. Read the questions over carefully and take your time in selecting an answer.

Press A 28

OK. The zinc plugs, rods etc., should be inspected. Don't be deceived by their outward appearance; tap the plug lightly with a screwdriver or small hammer. What condition should the zinc plugs or rods be in before they are replaced?

- 52A. After corrosion is removed there should be at least one-half of the original zinc left.
- 51 B. They never need replacing, as they will outlast the other materials.
- 51C. If they break when tapped with a screwdriver or hammer they are too brittle to be effective and should be replaced.

51

No. zincs should be replaced when there is one-half or less remaining after cleaning off the corrosion.

Use caution when tapping zincs with a screwdriver or hammer, as they will break if struck too hard. They will not outlast the other metals in the cooling system and they are put there to absorb the electrolytic action in the system.

Press A 52

OK. In order to retain cooling system efficiency, the tubes of the heat exchanger should be cleaned periodically. Don't overlook fan and water pump bearings. Lubricate, and be careful to keep grease off the

- 53 A. exhaust manifold
- 54 B. fan belts
- 53 C. alternator or generator

52

53

No. when lubricating the fan and pump bearings, be careful to keep grease off the fan and pump drive belts. An oil or grease soaked belt cannot transmit the power necessary to turn the fan and pump.

Press A 54

OK. Whenever it is necessary to drain the cooling system, particularly when flushing it or when shutting down without anti-freeze in the system during cold weather, be sure to open all the drain cocks in the system. Otherwise,

- 56 A. coolant may be trapped in the system, and when it freezes its volume expands about nine percent; the results can be expensive.
- 55 B. corrosion will take place in an idle engine to present problems when the engine is to be put back in service.
- 55 C. the engine should be flushed occasionally even if it contains anti-freeze or rust inhibitors.

54

55

No. Whenever it is necessary to drain the cooling system, be sure to open all the drain cocks in the system. Otherwise, coolant may be trapped in the system; when it freezes its volume expands about nine percent, and the results can be expensive, (a cracked block or cylinder head etc.).

The Service manual may recommend that the engine be flushed and new coolant installed.

Corrosion will develop in a dry radiator core after it has been used. If a cooling system is to be left empty for any length of time it should be sealed air tight.

Press A 56

OK. Before shutting down an engine that has been heavily loaded,

This will allow the coolant time to carry excess heat away from the engine and equalize temperatures throughout the engine.

- 57 A. race the engine a few times to hasten cooling the engine by heavy blasts of air from the fan.
- 57 B. let the engine idle without load for about 30 minutes.
- 58 C. let the engine idle without load for about 5 minutes.

56

57

No, racing the engine will not hasten the cooling of the engine; if anything it will delay the cooling.

It is unnecessary to idle the engine for over 5 to 10 minutes, as more harm than good will be done.

Press A 58

OK. Never add cold water to a hot cooling system when the engine is stopped. The cold water may cause _____

- 59 A. pieces of carbon in the combustion space to break off and damage the piston, valve or cylinder head
- 60 B. the engine parts to contract suddenly, and the result can be a cracked cylinder head or engine block
- 59 C. the engine to overspeed due to engine governor erratic operation

59

No, cold water added to the cooling system of a hot engine will cause the engine parts to contract suddenly and the result can be a cracked cylinder head or engine block.

Adding water to a hot engine would have no effect on the engine governor or engine speed, and it is doubtful if any pieces of carbon would break off and damage anything in the combustion space.

Press A 60

OK. If it is necessary to add cooling water (coolant) to a system that is low, keep the engine running and add water _____

- 61 A. quickly so it will all warm up together.
- 61 B. use hot water and eliminate the possibility of cracking the block or cylinder head.
- 62 C. slowly, so the added water can circulate through the engine and reach operating temperature without cooling any particular part more than others.

60

61

No, if the water is added quickly it will cause uneven expansion and maybe a cracked block or cylinder head. The use of hot water reduces the possibility of cracking the hot block or head but the water should be added slowly in any case, so it has an opportunity to reach operating temperature.

The expense resulting from unwise haste is not worth taking; follow the instructions recommended by the manufacturer.

Press A 62

OK. If recommended procedures are followed, difficulties with the cooling system will be held to a minimum. However, there is a methodical approach for correcting the most common cooling system problems. First, _____

- 61 A. make sure there is sufficient coolant in the system.
- 61 B. confirm that the engine is actually overheating or causing a problem

x C - 63
(The correct answer must be selected before you will move to the next frame.)

62

63

You have missed one or more of the questions in this section and should have the opportunity to go back for a review. Read the questions carefully and take your time in selecting an answer.

Press A 50

OK. In the methodical approach for correcting or finding cooling system problems, after checking the coolant level, the next step is to confirm that the engine is heating up (overheating) by using a reliable thermometer in the top tank of the radiator. The next step would be to _____

- 65 A. remove the radiator for cleaning and testing for leaks, etc.
- 66 B. remove leaves, mud and debris which have accumulated on the outside of the radiator core.
- 67 C. check water passages in the engine have not been plugged by deposits accumulating in the system.

64

No. After checking coolant level the next step is to remove leaves, mud and debris from the front of the radiator core, to allow air to pass through the core.

To check the water passages at this point would involve removing the cylinder head and several other steps of disassembly that may be unnecessary.

Press A 66

OK. The third step in the methodical method of checking cooling system for overheating, after checking coolant level and air flow restriction through the core, the next step would be to _____

- 67 A. remove the water pump for inspection
- 67 B. install new radiator hoses
- 68 C. check the fan belt for the proper tension and the pulleys for wear

66

No, the next step would not be to remove the water pump or install new radiator hoses. The simple things should be checked first. So next check the fan belt for proper tension and look for grease or oil on the belt or pulley that would cause the belt to slip.

Press A 68

OK. If the overheating continues to exist after a few steps of the methodical method (simple things first), start checking the more involved things next. How would the surrounding air temperature affect the cooling system?

- 69 A. The surrounding air would have little or no effect on the cooling system, as the temperature regulators control the coolant temperature.
- 70 B. If the surrounding air temperature is too high and the load on the engine approaches full load, even a cooling system in perfect condition may overheat.
- 69 C. The engine is water cooled and the surrounding air has no effect on the cooling system.

68

No, the surrounding air has a definite affect on the coolant in an engine. Even a cooling system in perfect condition may overheat, if the surrounding air temperature is high and the engine is loaded near its capacity.

Press A 70

OK. Next, remove the water temperature regulators and check their opening temperature. If the regulators are found to be in good condition, reinstall them before continuing with the test of the cooling system.

Never operate the engine unless the regulators are installed. Why?

- 71 A. The temperature regulators keep the engine temperature at its most efficient range.
- 71 B. Removing the regulators may appear to cure the overheating, but the operating temperature may drop so low that rust and sludge can form in the crankcase and cause extensive damage.
- 72 C. Both "A" and "B" are correct.

70

No, not just "A" or "B", but both are correct.

Most operators' manuals will warn against operating an engine without the temperature regulators. Extensive damage may result from the sludge that would form in the crankcase.

Press A 72

OK. Air inside the cooling system can cause overheating.

Air leakage can be determined by a simple but effective check known as the "_____".

- 73 A. beetle test
- 73 B. bubble test
- 74 C. bottle test

72

73

No; the bottle test is the correct answer and it is accomplished as follows:

After the engine has warmed up, stop the engine, make sure the radiator cap is tight. Put a rubber hose over the overflow tube and the other end in a bottle filled with water. Invert the bottle (turn upside down) in a bucket of water and run the engine at high idle speed. If the water inside the bottle is displaced by air, try tightening the cylinder head studs and precombustion chambers.

Press A 74

OK. If a leak is detected by the bottle method (or any other), and the cylinder head studs and precombustion chambers have been checked for tightness, what should be the next step?

- 75 A. Try the pressure test.
- 75 B. Try the vacuum test.
- 76 C. Check the cylinder head and precombustion chamber gaskets for damage.

74

75

No: the next step after detecting a leak is not the pressure or vacuum test to locate the leak.

It is to check the cylinder head and precombustion chamber gaskets for damage, and if that isn't the cause of the trouble, go on from there.

Press A 76

OK. After all the checking that has been mentioned up to this point has not located the overheating problem the next step is: check the water pump for loose or badly corroded impeller. Also inspect the seal and check for a worn or broken shaft. Inspect the water passages for sediment and scale deposits.

The condition of the _____, which come in contact with the coolant, give a good indication of the deposit build-up in the hotter areas of the engine.

- 78 A. precombustion chamber surfaces
- 77 B. cylinder head combustion space surfaces
- 77 C. piston and ring surface appearance

76

77

No. The condition of the precombustion chamber surfaces would give a good indication of the deposit build-up in the water passages in the cylinder block and cylinder head.

The cylinder head combustion space is inside the cylinder as is the piston and ring surfaces, and does not come in direct contact with the coolant.

Press A 78

OK. There are other conditions under which a well functioning system will not adequately cool the engine. One cause is operating a machine under a continuous overload that lugs the engine down below its rated speed. There is another possibility to be considered when overheating is encountered without apparent reason:

- A. lubricating oil too thin.
- 80 B. altitude at which engine is operating.

XC - 79

(The correct answer must be selected before you will go to the next frame.)

78

79

You have missed one or more answers in this series and should have the opportunity to go back for a review. Read the questions carefully and take your time in selecting an answer.

Press A

OK. The altitude at which the engine is operating should be considered when overheating is encountered. The available horsepower of the engine decreases as the altitude increases and the engine may be overloaded.

Also, the boiling point of water is affected with altitude; it _____

- A. goes up as altitude increases.
- B. goes down as altitude increases.
- C. goes up as altitude decreases.

80

81

No; the altitude at which the engine is operating should also be considered when overheating is encountered. The boiling point of water is lower at high altitudes than at sea level. This causes more rapid evaporation, and the coolant loss may be the cause of overheating.

The correct answer to the preceeding question is: the boiling point of water goes down as the altitude increases.

Either "B" or "C" is correct.

Press A

82

OK. One point should be emphasized in trying to find the cause of engine overheating; that is check the

- 83 A. fuel injection timing first.
83 B. lubricating oil quantity and quality first.
84 C. the cooling system first.

82

83

No, there is little chance that the fuel system, lubrication system or other parts of the engine are the cause of engine overheating. However, if something is wrong in the other systems, there will generally be other symptoms besides engine overheating. Remember, check the cooling system first.

Press A

84

OK. If the proper coolant is used and the scheduled maintenance procedures recommended are followed, cooling system difficulties can be minimized or

- 85 A. eliminated
85 B. delayed and prolonged
85 C. both "A" and "B" are correct

84

85

Any one of the three answers on the previous frame is correct. The object of scheduled maintenance is to eliminate cooling system difficulties, which is next to impossible. So we prolong the service life of an engine by delaying failures through recommended maintenance programs.

Press A

Congratulations, you have just completed the Unit on cooling systems ... Please press REWIND

86

AM 1-32

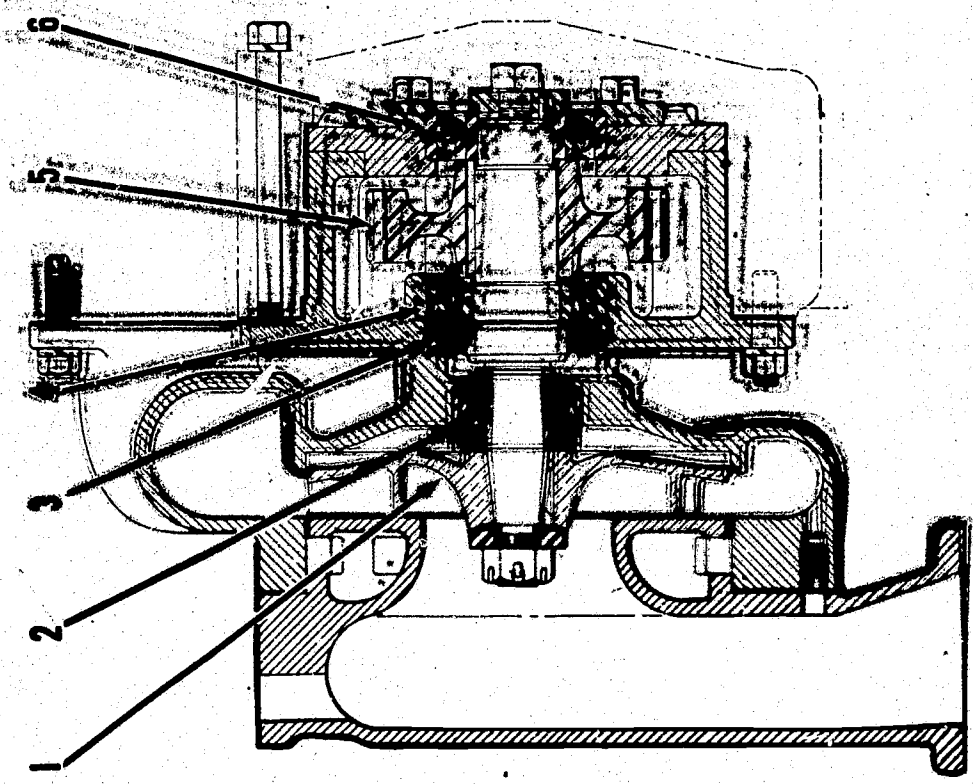

WATER PUMP
1-Bearing, 2-Valve seal, 3-Oil seal, 4-Bearing.
5-Shaft, 6-Bearing.

INSTRUCTOR'S GUIDE

Title: I -- CATERPILLAR DIESEL ENGINE COOLING SYSTEM
D-8 AND 824 MODELS

AM 1-25
9/16/66

II -- TIRES AND TIRE HANDLING

OBJECTIVES:

1. To present to the student the theory of cooling as related to the CAT engine.
2. Introduce the different components that make up the CAT cooling system, how they function and their role in the overall system.
3. To refresh the student's memory of how to properly care for the cooling system, not only for CAT engine's but all types.
4. To give a brief description of heavy duty tire and rim construction.

LEARNING AIDS suggested:

VUE CELLS: AM 1-4 (5) (Coolant flow control-thermostat)
 AM 1-4 (6) (Thermostat Operation)
 AM 1-4 (8) (Radiator Pressure Control Cap)
 AM 1-25 (1) (D-8 CAT Water Pump)

MODELS: Any models of CAT cooling system components
 that can be easily brought into class would be
 helpful for demonstration and explanation purposes.

QUESTIONS FOR DISCUSSION AND GROUP PARTICIPATION:

1. Do diesel engines use all the mechanical energy created from the burning of fuel?
2. Does a diesel engine water pump circulate very much water?
3. In what area does the coolant circulate when the engine is first started?
4. What are the two reasons for having a pressurized cooling system?
5. How is pressure in the cooling system maintained?
6. As the coolant temperature rises, does the pressure increase or decrease? Why?
7. When would internal engine pressure drop below atmospheric pressure?
8. Why must the formation of scale be guarded against in all engines? Explain.
9. What is the best method of retarding the formation of scale in the cooling system?
10. What can happen if fan belts are too tight?
11. What happens to engine parts when cold water is added to a hot engine?