

R E P O R T R E S U M E S

ED 021 092

VT 005 675

AUTOMOTIVE DIESEL MAINTENANCE 1. UNIT XXI, I--MAINTAINING THE AIR SYSTEM--CATERPILLAR DIESEL ENGINE, II--UNDERSTANDING REAR END SUSPENSION.

HUMAN ENGINEERING INSTITUTE, CLEVELAND, OHIO

REPORT NUMBER AM-1-21

PUB DATE 9 AUG 66

MINNESOTA STATE DEPT. OF EDUCATION, ST. PAUL

EDRS PRICE MF-\$0.25 HC-\$1.80 43P.

DESCRIPTORS- *STUDY GUIDES, *TEACHING GUIDES, *TRADE AND INDUSTRIAL EDUCATION, *AUTO MECHANICS (OCCUPATION), *DIESEL ENGINES, ADULT VOCATIONAL EDUCATION, TRANSPARENCIES, PROGRAMED MATERIALS, INDIVIDUAL INSTRUCTION, INSTRUCTIONAL FILMS, PROGRAMED INSTRUCTION, MOTOR VEHICLES, EQUIPMENT MAINTENANCE,

THIS MODULE OF A 30-MODULE COURSE IS DESIGNED TO DEVELOP AN UNDERSTANDING OF THE OPERATION AND MAINTENANCE OF THE DIESEL ENGINE AIR SYSTEM AND REAR AXLE SUSPENSION USED ON DIESEL POWERED VEHICLES. TOPICS ARE (1) AIR INDUCTION AND EXHAUST SYSTEM, (2) VALVE MECHANISM, (3) TROUBLESHOOTING THE AIR SYSTEM, (4) PURPOSE OF VEHICLE SUSPENSION, (5) TANDEM DRIVE AXLE SUSPENSION, AND (6) COMPRESSED NITROGEN CYLINDER SUSPENSION SYSTEM. THE MODULE CONSISTS OF A SELF-INSTRUCTIONAL BRANCH PROGRAMED TRAINING FILM "MAINTAINING THE AIR INTAKE AND EXHAUST SYSTEMS--CATERPILLAR DIESEL ENGINE" AND OTHER MATERIALS. SEE VT 005 655 FOR FURTHER INFORMATION. MODULES IN THIS SERIES ARE AVAILABLE AS VT 005 655 - VT 005 685. MODULES FOR "AUTOMOTIVE DIESEL MAINTENANCE 2" ARE AVAILABLE AS VT 005 685 - VT 005 709. THE 2-YEAR PROGRAM OUTLINE FOR "AUTOMOTIVE DIESEL MAINTENANCE 1 AND 2" IS AVAILABLE AS VT 006 006. THE TEXT MATERIAL, TRANSPARENCIES, PROGRAMED TRAINING FILM, AND THE ELECTRONIC TUTOR MAY BE RENTED (FOR \$1.75 PER WEEK) OR PURCHASED FROM THE HUMAN ENGINEERING INSTITUTE, HEADQUARTERS AND DEVELOPMENT CENTER, 2341 CARNEGIE AVENUE, CLEVELAND, OHIO 44115. (HC)

STUDY AND READING MATERIALS

AUTOMOTIVE DIESEL 1 MAINTENANCE

U.S. DEPARTMENT OF HEALTH, EDUCATION & WELFARE
OFFICE OF EDUCATION

THIS DOCUMENT HAS BEEN REPRODUCED EXACTLY AS RECEIVED FROM THE
PERSON OR ORGANIZATION ORIGINATING IT. POINTS OF VIEW OR OPINIONS
STATED DO NOT NECESSARILY REPRESENT OFFICIAL OFFICE OF EDUCATION
POSITION OR POLICY.

I -- MAINTAINING THE AIR SYSTEM --
CATERPILLAR DIESEL ENGINE

II -- UNDERSTANDING REAR END SUSPENSION.

UNIT XXI

Part I

SECTION A

AIR INDUCTION AND EXHAUST
SYSTEM

SECTION B

VALVE MECHANISM

SECTION C

TROUBLESHOOTING THE AIR
SYSTEM

Part II

SECTION A

PURPOSE OF VEHICLE
SUSPENSION

SECTION B

TANDEM DRIVE AXLE SUSPENSION

SECTION C

COMPRESSED NITROGEN CYLINDER
SUSPENSION SYSTEM

AM 1-21
8/9/66

Human Engineering
Institute

Minn. State Dept. of Ed.
Vocational Education

HUMAN ENGINEERING INSTITUTE

ED021092

VT005675

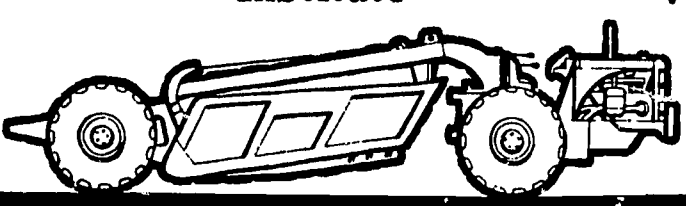
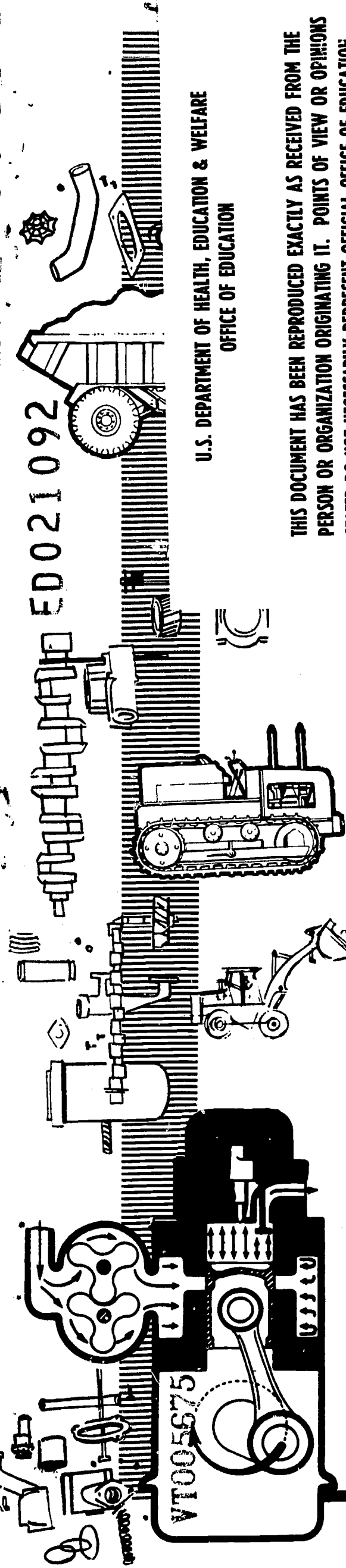

This unit is divided into two parts. The first part covers the first in a series of ten units on the Caterpillar diesel engine. The second part is a brief discussion on rear end suspension of vehicles.

I -- MAINTAINING THE AIR SYSTEM -- CATERPILLAR DIESEL ENGINE

This is the first in a series of ten class units covering the Caterpillar engine. As in previous units on coverage of diesel engines, (GM and Cummins), these units are designed to improve the diesel mechanic's knowledge so he can better understand his job and do it better.

Coverage of the Caterpillar engine, hereafter referred to as "CAT", begins with one of the four flows-air induction and exhaust system.

SECTION A -- AIR INDUCTION AND EXHAUST SYSTEM

Operation -- Basically, all diesel engine air systems are similar and Cat engines are no exception. The air system serves to: clean the air, furnish adequate air needed for combustion, furnish additional air for scavenging (two cycle engines), and furnish air for turbocharged engines.

Cat engines are of the four cycle type similar to the Cummins engine, with the exception that most Cat engines are equipped with a turbocharger. These engines have two intake and two exhaust valves for each cylinder and have the conventional inlet and exhaust manifolds.

Air Flow -- Before getting involved with each component of the Cat air system, let's trace the air through a typical Cat turbocharged system by looking at Figure 1. After we have seen what route the air follows, we'll discuss each component separately.

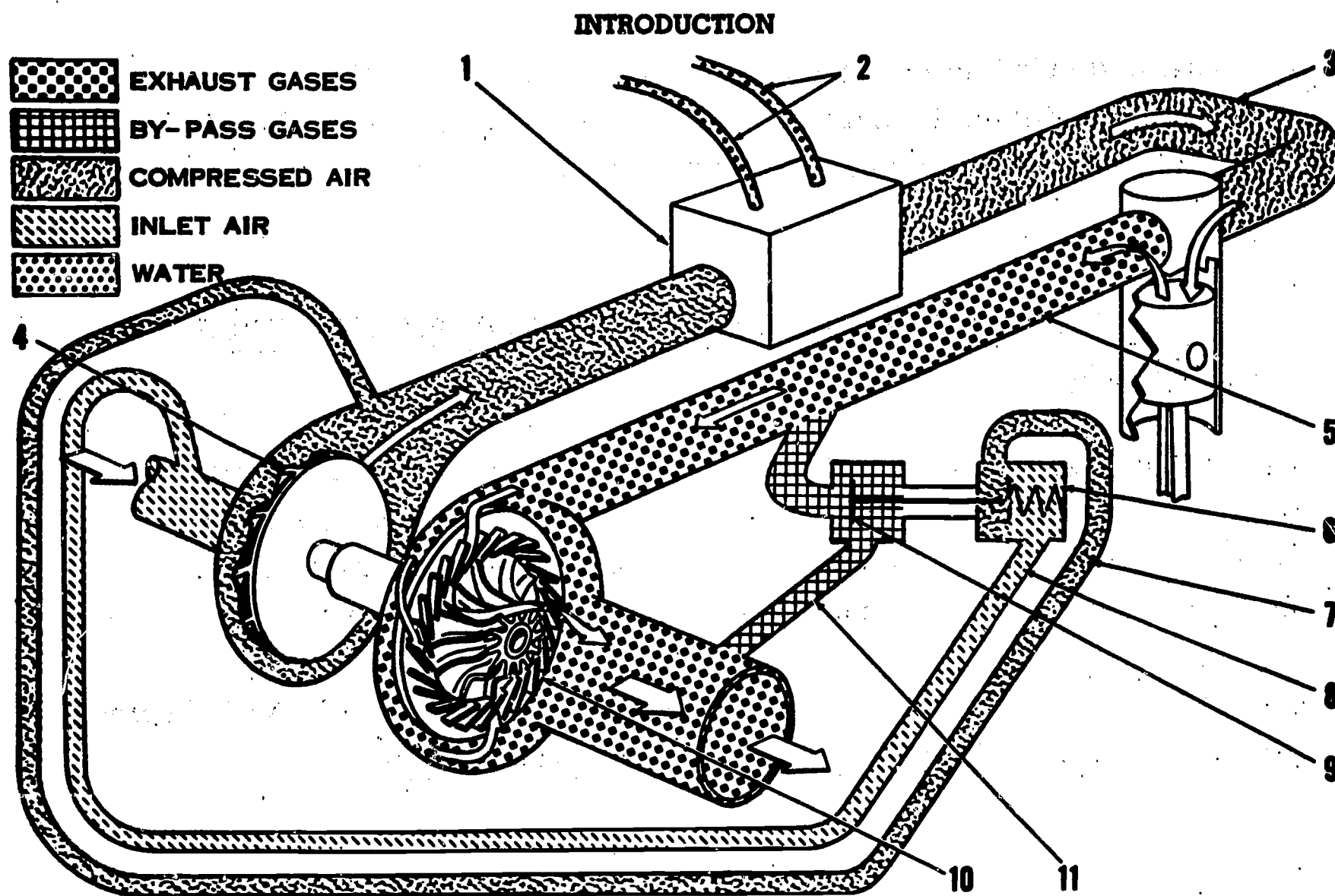

AIR INDUCTION AND EXHAUST SYSTEM (SCHEMATIC)

1-Aftercooler. 2-Water lines. 3-Inlet manifold. 4-Turbocharger impeller. 5-Exhaust manifold. 6-Air pressure ratio control regulator. 7-Line (inlet manifold pressure). 8-Line (impeller inlet pressure). 9-Bypass valve. 10-Turbocharger turbine. 11-Exhaust bypass tube.

Fig. 1 Turbocharged engine air system.

As the engine starts, the flow of exhaust gases from the exhaust manifold (5), (Figure 1), is directed to the turbine wheel (10) in the turbocharger. The exhaust bypass valve (9) is closed at this time. Energy contained in the exhaust gases drives the turbine wheel as the gases pass through the blades and out the exhaust system. Since the turbocharger impeller (4) is mounted on the same shaft as the turbine wheel, the impeller is also forced to rotate. The impeller draws air (suction) in through its center and expels it around the casing or volute, resulting in a pressure rise in the inlet manifold.

As more fuel is added to the air fuel mixture, more energy is passed on to the exhaust gases. The turbine wheel speed is increased and the impeller speed is increased the same amount (common shaft). This forces more air into the cylinders. When the load is reduced, or engine speed is changed from high rpm to a lower rpm, the exhaust gas energy is reduced, and less air passes through the impeller.

A water-cooled heat exchanger, or after-cooler (1) is similar to the one we discussed on a Cummins engine and it performs the same function. On the Cat it is installed between the compressor (impeller) and the air inlet manifold. Since the air (after being compressed by the impeller) is raised in temperature, the heat exchanger (after-cooler) serves to reduce the air temperature, makes the air more dense and enables more pounds of air to be packed into the engine cylinders. By the same token, the reverse is true in extreme cold weather; then heated water running through the exchanger from the engine's cooling system serves to heat up the air. In extreme cold weather, there is a little different situation. Remember in Unit AM 1-14, we said that cold weather tends to increase the density of air. Actually the nitrogen content is decreased, leaving more oxygen per cubic volume of air. This condition often creates engine problems, (over-combustion). Steps often have to be taken to counteract this situation and to prevent burning the engine up.

So far we have discussed only an uninterrupted flow of exhaust gases through the turbocharger. A pressure ratio control system is utilized to control the flow of exhaust gases through the turbine wheel. This is accomplished by (6) the air pressure ratio control regulator which maintains the turbocharger speed at the desired level.

Pressure Ratio Control System -- The pressure ratio control system uses a pneumatically operated pressure ratio control regulator. For location of this component, see Figure 2 (2), for a cutaway view, see Figure 3.

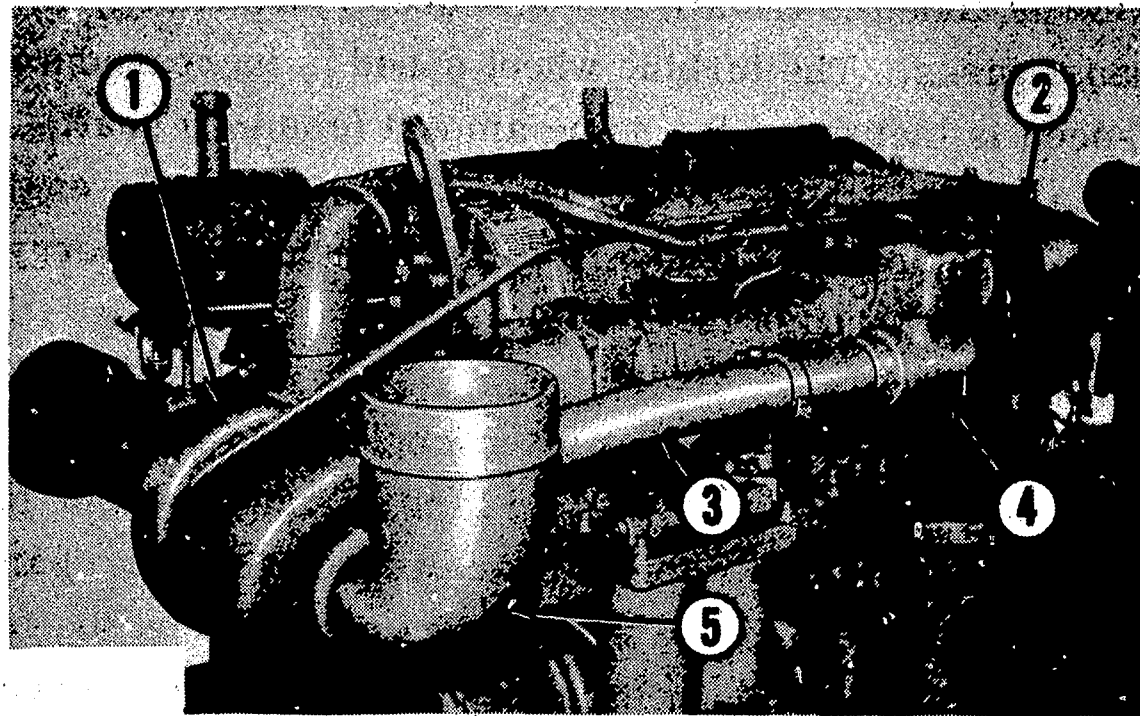

PRESSURE RATIO CONTROL SYSTEM

1-Turbocharger turbine. 2-Pressure ratio regulator. 3-Bypass tube. 4-Bypass valve housing. 5-Exhaust elbow.

Fig. 2 Pressure ratio control system.

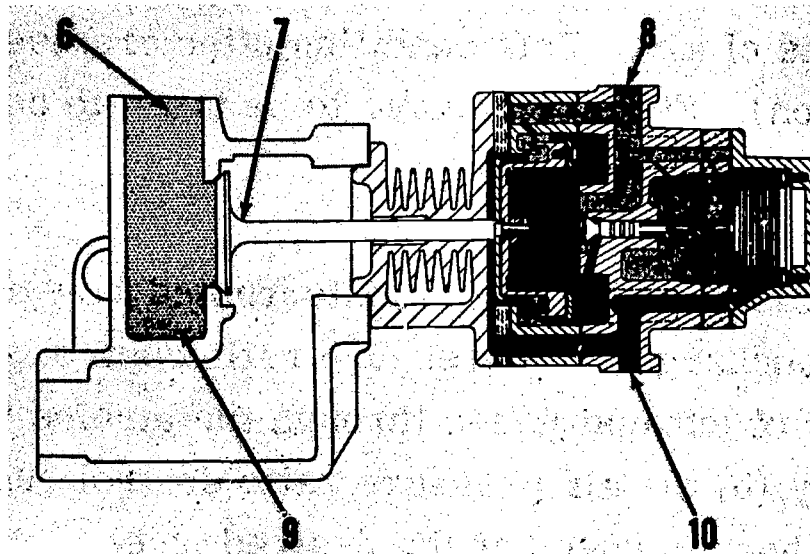

PRESSURE RATIO REGULATOR OPERATION (BYPASS VALVE CLOSED)

6-From exhaust manifold. 7-Bypass valve. 8-Pressure line connection (turbocharger compressor inlet). 9-Exhaust gases. 10-Pressure line connection (turbocharger compressor outlet).

Fig. 3 Pressure ratio regulator (valve closed).

This regulator is used to maintain the desired ratio between the turbocharger inlet air pressure (8) Figure 3 and turbocharger compressor outlet pressure, (10) Figure 3 throughout the normal operating range of the engine. This control maintains the ratio by limiting the volume of exhaust gases passing through the turbine, which in turn controls the impeller speed. To slow down the turbine, exhaust gases bypass the turbine and are directed out the exhaust bypass tube (3) Figure 2 to the exhaust elbow (5) Figure 2.

With the bypass valve (7) Figure 3 CLOSED, all the exhaust gases (9) Figure 3, are directed through the turbine (1) Figure 2, and the speed of the turbocharger will increase, causing the air pressure to increase in the regulator passages (dark colored area), Figure 3 and inlet manifold. This condition occurs upon initial starting or when there is an abrupt change from a slight or no load condition to a load condition.

When the pressure ratio (impeller outlet pressure), (10) Figure 3 to inlet pressure (8) Figure 3 reaches the predetermined maximum, the diaphragm (B) Figure 4 moves to the left pushing the poppet valve (13) Figure 4 off its seat. Opening the poppet valve causes pressure in cavity (A) Figure 4 to drop to turbocharger inlet line pressure. Since the pressure in cavity (A) Figure 4 is now lower than pressure behind diaphragm (C) Figure 4, the bypass valves OPENS and a portion of the exhaust gas bypasses the turbine (1) Figure 2.

With a portion of the gas bypassing the turbine, the turbine tends to slow down and to stabilize, holding the desired maximum pressure ratio. As the load on the engine decreases, the volume of gas decreases, causing the turbine to slow down, thus decreasing the output pressure (10) Figure 4 and allowing the poppet valve (13) Figure 4 to close. When the poppet valve closes, the pressure in cavity (A) Figure 4 equalizes with outlet pressure (10) Figure 4 through the orifice (12) Figure 4, allowing the spring to close bypass valve (7) Figure 4.

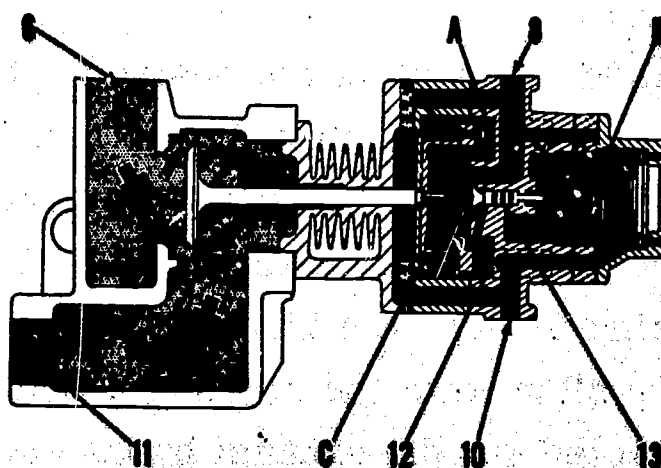

**PRESSURE RATIO REGULATOR OPERATION
(BYPASS VALVE OPEN)**

6-From exhaust manifold. 8-Pressure line (turbocharger compressor inlet). 10-Pressure line (turbocharger compressor outlet). 11-To exhaust piping. 12-Orifice. 13-Poppet valve. A-Cavity. B-Diaphragm. C-Diaphragm.

Fig. 4 Pressure ratio regulator (valve open).

INLET MAINFOLD -- The inlet manifold is located on the left side of the engine (facing the front). The manifold is connected at each inlet port by a three-bolt flange.

The Cat engine is unique compared to the GM or Cummins engine in that, the Cat has a built-in starting aid. A tube (exhaust) from the two cylinder gasoline starting engine runs the entire length of the intake manifold for the diesel engine, see (2) Figure 5. These hot gases preheat the air in the intake manifold, (1) Figure 5.

A bellows is incorporated in the center of the tube assembly to permit expansion. Each end of the tube assembly is sealed with a bushing and retainers to minimize the possibility of starting engine exhaust gases, dust or dirt entering the diesel engine through the inlet manifold.

Gaskets form seals for the starting engine exhaust elbow connection to the manifold, between the two sections of the manifold, and for the starting engine exhaust pipe at the front of the manifold. O-ring seals are located in the joints of the inlet pipe between the turbocharger and the inlet manifold.

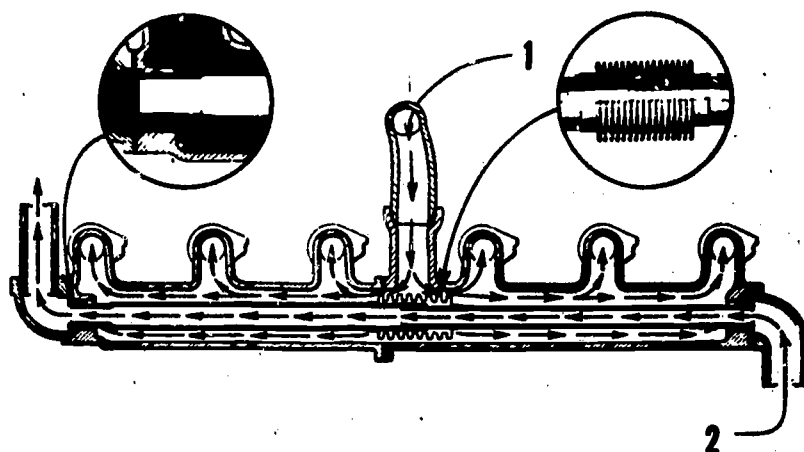

DIESEL ENGINE INLET MANIFOLD
 1-Diesel engine inlet air. 2-Starting engine
 exhaust gases.

Fig. 5 Diesel engine inlet manifold.

EXHAUST MANIFOLD -- The exhaust manifold is located on the left side of the engine (facing the front). The manifold is constructed in two sections. The front section fits into the rear section and the joint is sealed by rings. The rear section has a pad for mounting the turbocharger and also a mounting support for the exhaust pipe.

Air Cleaner -- Much has been said about air cleaners in past units. Cat engines use basically the same types as do GM and Cummins engines.

There is one air cleaner on the market that we haven't mentioned, however, that is rapidly becoming more widely used than the conventional type. This is the FARR square type air cleaner that has replaceable pleated paper type filter elements. A unique and very effective characteristic of this air cleaner is the aspirator attachment that is optional equipment on the two stage model.

Figure 6 shows the flow of air through this filter. As air enters the pre-cleaner panel at a fast pace, it is swirled rapidly by the fins located in the face of the pre-cleaner. This spinning of the air by centrifugal force removes 90 percent of the dust particles down to 5 to 10 micron size, leaving all particles below that size to be removed by the paper filters.

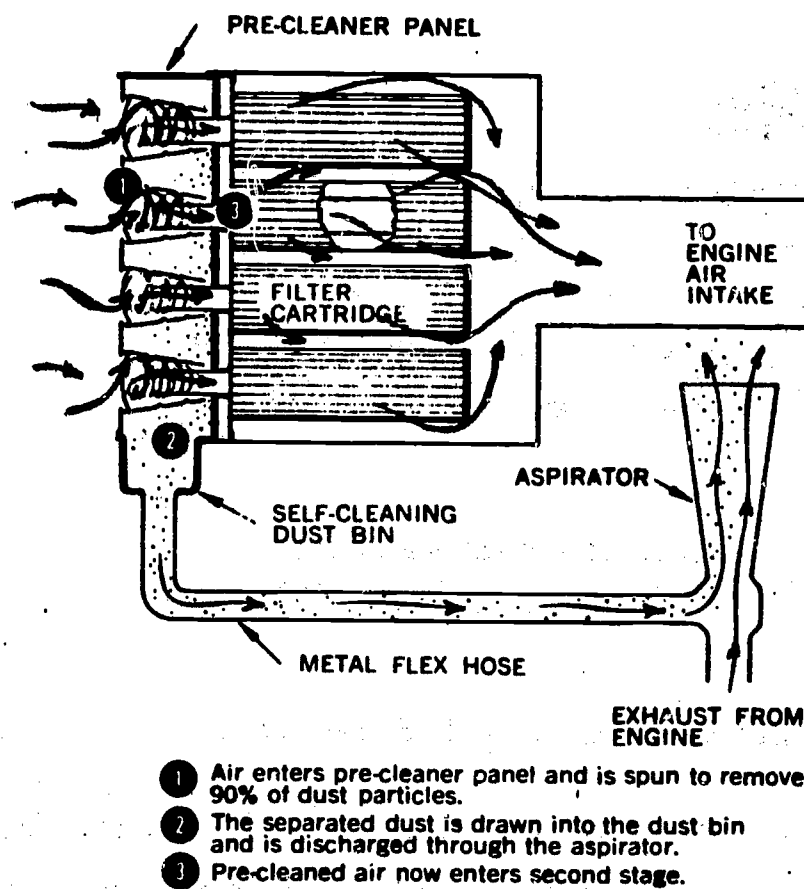

Fig. 6 FARR air cleaner.

The dust particles removed by spinning drop into a dust bin where they are removed through the metal flex hose into the aspirator and out the exhaust. The reason the dust particles are drawn from the dust bin is because of the slight vacuum that is created from the flow of exhaust gases from the engine. This is called a "venturi" and it works on the same principle as a carburetor in a gasoline engine. Another example of the venturi principle is that of using a glass jar full of insecticide solution which has a garden hose adapter with an orifice. The water rushing over the orifice pulls a precise amount of solution from the jar, depending on the diameter of the tube, and the two liquids mix and expel from the nozzle; see Figure 7.

Another type of dry air cleaner commonly seen on Cat equipment is the horizontally mounted type with a pre-cleaner. Figure 8 shows this type of cleaner. The primary element (1) Figure 8, can be removed and cleaned with air pressure, or by washing. **NOTE:** Use proper washing procedures

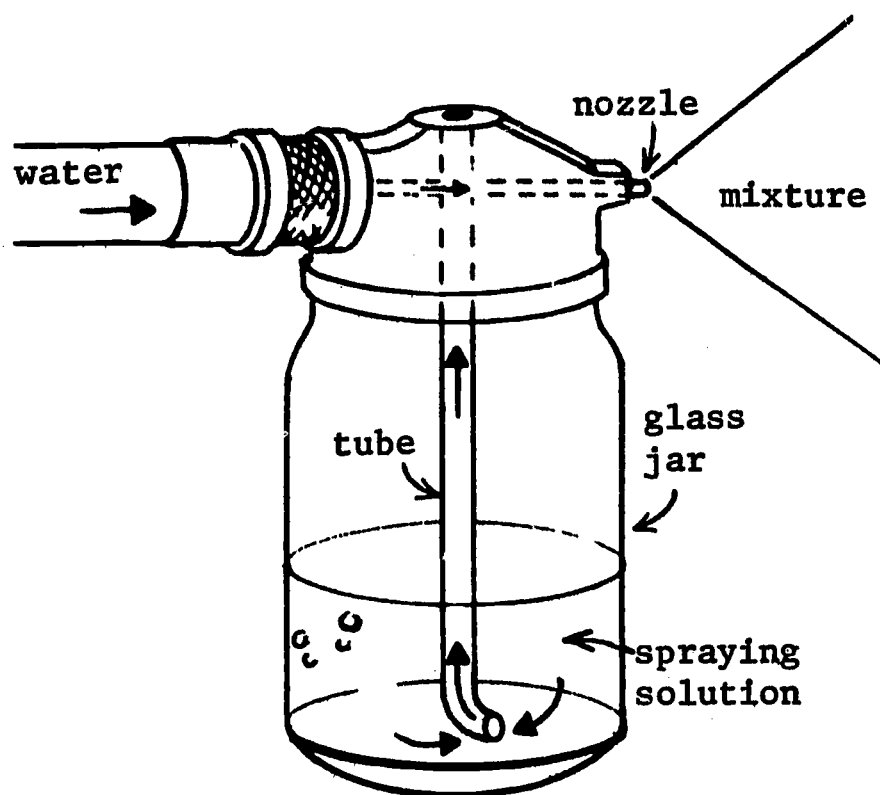
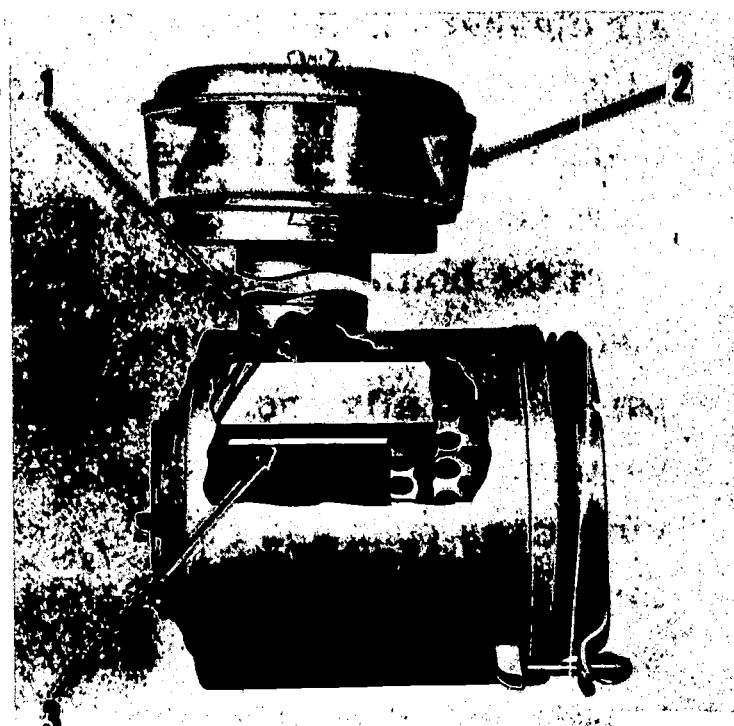

Fig. 7 Venturi principle.



AIR CLEANER
1-Primary element. 2-Precleaner. 3-Secondary element.

Fig. 8 Air cleaner.

as recommended by the service manual. A secondary element (3) Figure 8, is provided in case of a rupture in the primary element. The secondary element should be removed and cleaned periodically in accordance with proper servicing instructions. A full view pre-cleaner (2) Figure 8, is mounted on the extension of the filter body assembly.

Air Flow -- Figure 9 shows the flow of air through this cleaner; let's trace it.

During operation, air from the pre-cleaner flows around the outside and through the elements to the center of the air cleaner, and from there to the inlet manifold. Air is prevented from bypassing the primary element by a seal (4) Figure 9 which is bonded to the end of the primary element. Steel plates (5) Figure 9 cover and seal one end of each element. Gaskets (6) Figure 9 between the secondary element, body assembly and air transfer pipe, prevent unfiltered air from being drawn into the engine at these points.

Another attachment for dry type air cleaners is the sneezer.

This is a rubber tube which has a small opening and acts as a valve to let water and dust escape from the bottom reservoir of the cleaner. Even though the dust pan is normally under a slight vacuum, the pulsations and vibrations open and close this valve, expelling dust and water. In some cases, this attachment eliminates the daily chore of dust cup servicing.

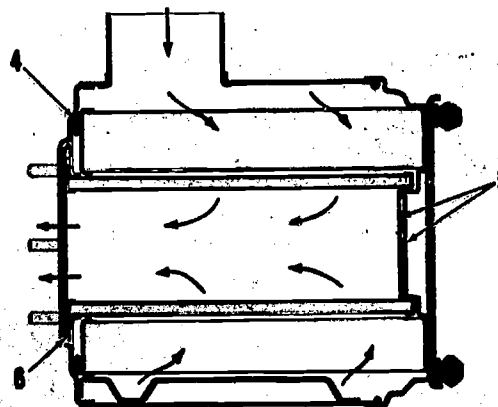

AIR CLEANER AIR FLOW
4-Seal. 5-Plates. 6-Gaskets.

Fig. 9 Air cleaner, air flow.

NOTE: Before moving on to the turbocharger, it should be mentioned that Cat engines use all solid piping for intake hoses, no flexible hoses or clamps.

TURBOCHARGER -- The Cat turbocharger is identical in operation to the GM and Cummins types. There is no need to repeat its principle of operation or construction. It is designed and used for one purpose, and that is to increase the engine's output by forcing additional air into the combustion chamber over and above the air that normally enters the engine due to atmospheric pressure.

Altitude Operation -- The maximum turbocharger speed is determined by the rack setting, the high idle speed setting (to be discussed later), the pressure ratio control setting, on engines so equipped, and the altitude at which the engine is operated. The rack setting has been set to permit the engine to be operated at the altitude given on the warning plate on the instrument panel or valve cover. The high idle speed setting is not the

same for all altitudes. If the high idle speed or the rack setting is greater than specified for the altitude at which the engine is operated, serious damage to engine or turbocharger parts may result.

The maximum altitude at which the engine can be operated is specified on the altitude warning plate located on the valve cover or instrument panel. The governor housing and turbocharger are sealed to prevent serious engine damage, or personal injury, due to operation of the engine with incorrect settings or turbocharger nozzle. Changes to the turbocharger rack setting, or high idle speed should be made only by authorized personnel.

The engine can be operated at a lower altitude than specified on the warning plate without danger of engine damage, but with slightly less than maximum performance. When operated at a higher altitude, the rack setting and high idle speed setting must be changed only by authorized personnel. After making any changes, the new altitude limit should be stamped on the altitude warning plate.

Also, the new high idle, full load speed, and rack setting should be stamped on the governor warning plate. Reseal the governor housing for continued protection.

PRIORITY VALVE -- It is not the intention of this unit to get into the Cat lubrication system. However, since this particular valve involves the turbocharger we will cover it briefly. Cat engines equipped with turbochargers have what is called a priority valve. The purpose of this valve is to restrict lubricating oil from getting to any part of the engine until the turbocharger bearings have been supplied. Once this is done, the valve opens and oil is circulated as usual. This is a safety feature that Cat has, to protect the turbocharger from damage through lack of lubrication. More will be said about this valve in the lubrication unit.

SECTION B -- VALVE MECHANISM

Conventional Type -- This Cat engine, found on the well known D-8 tractor, is very similar to the Cummins and GM diesel engine as far as the camshaft, push rods, rocker arms, etc. are concerned. There is no need to repeat the principles of operation or construction of this mechanism again. All three engines' valve mechanisms admit inlet air and release exhaust gases at precisely timed intervals during engine operation (except the two cycle GM engine).

The Cat valve mechanism for this engine is shown in Figure 10. You notice in the figure that something new is included, a **VALVE ROTATOR**, which is not present on the other two engines. Before covering the valve rotor, let's talk about the A and B series Cat engine.

The series A and B Cat engine is unique, as is shown in Figure 11.

Valve Operation (Series A and B)-

Two inlet and two exhaust valves are used for each cylinder, with seats consisting of hardened steel inserts (14) Figure 11, driven into the cylinder head. The valves are operated directly by the cam lobes on the dual overhead camshafts (4) Figure 11. The cam followers (6) Figure 11 follow the cam lobes and transmit this movement directly to the valves which are held closely by the springs (8) Figure 11. The valves move in replaceable guides (11) Figure 11 which are pressed into the head.

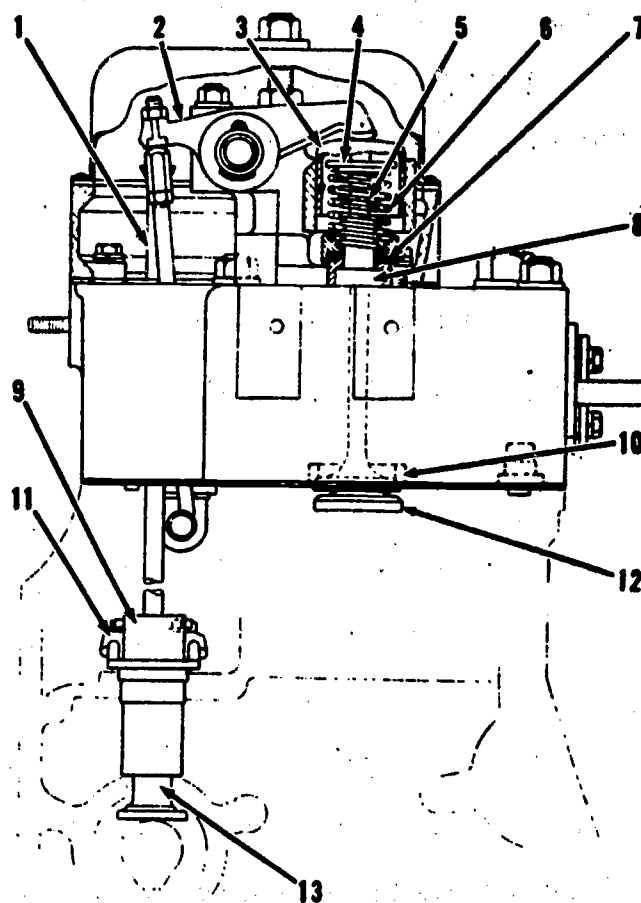

VALVES AND VALVE MECHANISM
 1-Push rod. 2-Rocker arm. 3-Sleeve. 4-Retainer. 5-Inner spring. 6-Outer spring. 7-Rotator. 8-Valve stem bushing. 9-Valve lifter guide. 10-Insert. 11-Retainer. 12-Valve. 13-Valve lifter.

Fig. 10 Conventional CAT engine.

To release compression for starting purposes, one inlet valve per cylinder is held open. This is accomplished by the compression release shaft (1) Figure 11 acting against the rocker arm (3) Figure 11, which in turn actuates the inlet valve (13) Figure 11. In the RUN position, the release shaft is rotated so that no interference occurs.

The compression release mechanism is adjusted by turning the adjusting screw (2) Figure 11. The valve clearance is adjusted by a Phillips head screwdriver inserted into the cam follower, see Figure 12, to engage the gear (7) Figure 11 on the adjusting mechanism.

The valve adjusting mechanism back (5) Figure 11 retains the adjusting mechanism to prevent change during operation.

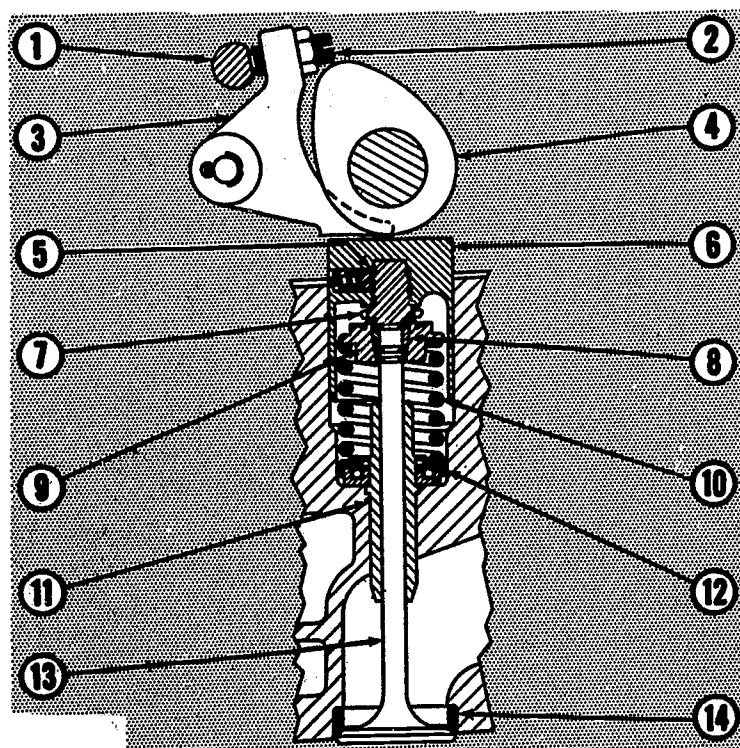

VALVE MECHANISM
(Inlet Valve)

1-Compression release shaft. 2-Adjusting screw. 3-Compression release rocker arm. 4-Camshaft. 5-Valve adjusting mechanism lock. 6-Cam follower. 7-Gear on adjusting mechanism. 8-Keeper. 9-Spring retainer. 10-Valve spring. 11-Valve guide. 12-Valve rotator. 13-Valve. 14-Valve seat insert.

Fig. 11 Series A and B Cat engine.

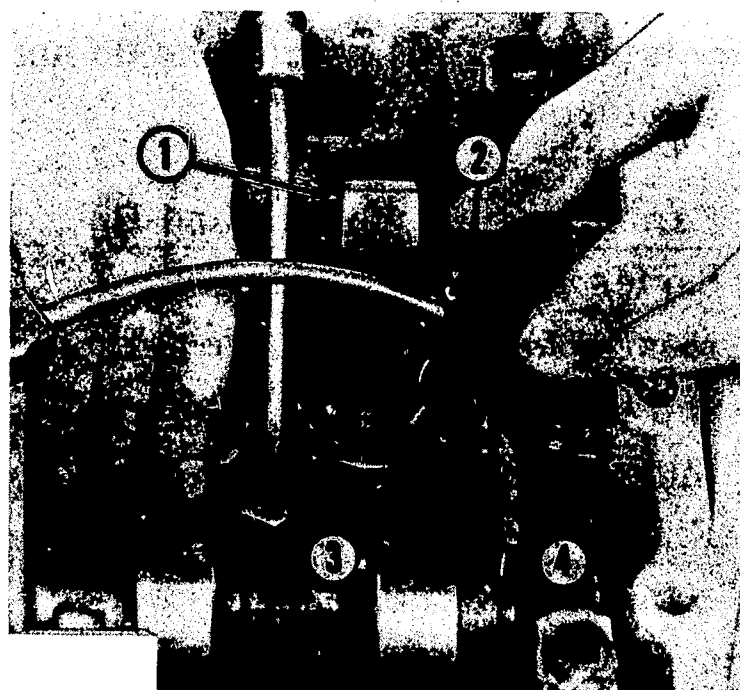

VALVE ADJUSTMENT

1-Camshaft. 2-Screwdriver. 3-Thickness gauge. 4-Cam follower.

Fig. 12 Valve adjustment.

Valve Rotator -- The valve rotator (8) Figure 11 is common to all Cat engines. This mechanism rotates the valves approximately 3° each time the valve is opened. It consists of a valve spring seating collar, see (14) Figure 13, spring washer (13) Figure 13, retainer body (15) Figure 13 and five steel balls (16) Figure 13.

As the valves are pushed off their seats, the valve springs are compressed, which, in turn, exerts a force against the valve spring seating collar and this, in turn, compresses the spring washer. The retainer body contains five steel balls which are held on the high end of an incline by springs.

As the spring washer is compressed, the steel balls are forced down the incline, thus rotating the spring washer, the valve spring seating collar, the valve springs and the valve. As the valve closes, the tension is released from the spring washer so that it no longer contacts the steel balls. Therefore, the travel of the balls back to their original position has no rotating effect on the valves. To determine whether a valve rotator is operating, observe the serrations on the top of the valve spring retainer. If the serrations do not rotate during operation, replace the valve rotator as a unit.

Camshaft Assembly (A and B Series Engines) -- As mentioned earlier, there are two camshafts side by side on this series of engines, see Figure 14. The exhaust camshaft is connected to the camshaft drive gear by the camshaft drive shaft. The inlet camshaft is driven by the exhaust camshaft through phasing gears located at the front of the camshaft assembly; see Figure 15.

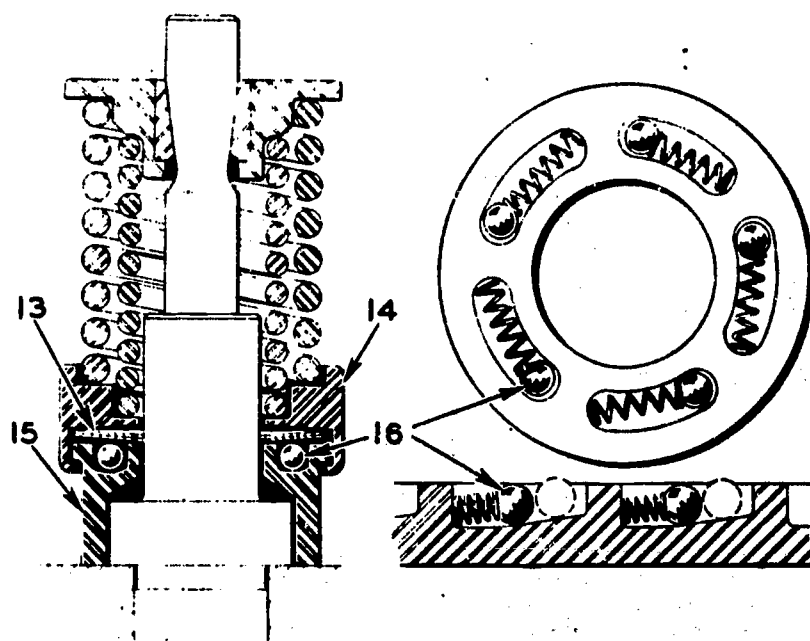

VALVE ROTATOR
13-Spring washer. 14-Spring seating collar. 15-Retainer body. 16-Steel ball.

Fig. 13 Valve rotator.

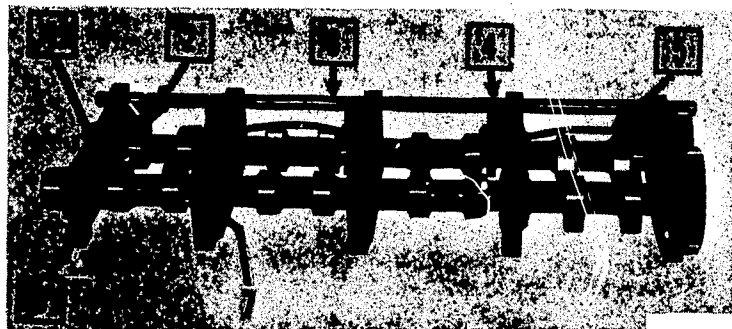

PREPARING TO DISASSEMBLE CAMSHAFT ASSEMBLY
 1-Thrust plate. 2-Compression release positioning assembly. 3-Compression release shaft. 4-Compression release rocker arms (four). 5-Camshaft bearing oil supply line. 6-Camshaft bearing block. 7-Camshaft bearing.

Fig. 14 Dual camshaft arrangement.

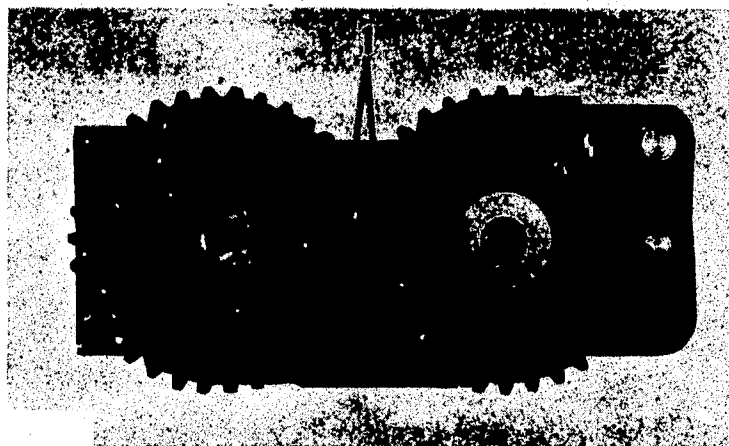

CAMSHAFT PHASING GEARS
 1-Timing marks.

Fig. 15 Camshaft phasing gear.

SECTION C -- TROUBLESHOOTING THE AIR SYSTEM

Turbocharger Bearings -- A quick check of bearing condition can be made without disassembling the turbocharger. This can be done by inspecting the compressor impeller, turbine wheel and housings. If there is no indication of either the impeller or turbine rubbing the housing, the bearing clearances are generally satisfactory.

A more reliable check of bearing condition can be made only when the turbocharger is disassembled and the bearings, shaft journal and housing bore diameter can actually be measured. See the maintenance manual for this procedure.

NOTE: While the turbocharger is disassembled, carefully check the back surfaces of the compressor impeller and turbine wheel for signs of contact with the housing. Contact in these areas would indicate worn thrust ring or washers.

Turbocharger Shaft End Clearance -- A dial indicator is needed to check shaft end clearance. It can be measured either on the engine, or off the engine. If the permissible clearance is exceeded, the turbocharger should be reconditioned. See the maintenance manual for turbocharger shaft end clearance specifications.

NOTE: Before disassembling the turbocharger, mark the positions of the compressor housing and turbine housing relative to the main housing. This assures correct positioning of the compressor air outlet and oil connections during the assembly.

Pressure Ratio Control System -- There are a number of checks that can be made on the Cat engine before it is necessary to remove and test the pressure ratio control system. Be sure to check the maintenance manual for proper testing of this equipment.

If the engine lacks power and smokes when lugged, the pressure ratio control valve may be sticking. The valve should be flushed with air to remove any foreign material that could be lodged in the poppet valve seat.

Also the exhaust bypass valve may be stuck open when the engine is running. To be sure of this, remove the inspection plug in the bypass valve housing. If gases are bypassing the valve, repair or replace the valve assembly.

Engine surges -- When this occurs, more than likely there is air in the fuel, and the fuel system should be bled.

Engine Shuts Down and Will Not Start Without Bleeding the Fuel System -- Again this condition may be caused by air in the fuel. May be there is a leaking or broken fuel supply line to the transfer pump.

It's possible that the fuel filter may be plugged. If so, replace the elements. There may also be an obstruction in the fuel supply line, or the line may be shut-off or only partly open.

Turbocharger Impeller Fails -- If impeller fails, the fault could have been in either the control system or in the turbocharger itself. It is necessary to check out the control system. Look for the possibility of the pressure ratio control valve being stuck in the CLOSED position or for improper adjustment of the control (wrong pressure ratio setting). Since this last check cannot be made on the engine, it is wise to check the pressure ratio control setting, unless a fault is definitely found in the turbocharger.

Also the low air pressure pickup line may be broken, which would cause overspeeding (only if the air cleaners were clogged). In this case replace the line and clean the air cleaners.

Alternate Checks -- The following are some checks that can be made to determine if the pressure ratio control assembly is operating properly.

1. With the engine stopped, remove the inspection plug in the bypass valve housing and look up with an inspection mirror. The exhaust bypass valve should be closed. Start the engine and run at idle speed. Use a mirror and again look at the bypass valve. The exhaust bypass valve should still be closed. If it is not closed, replace the control and repeat the check. If the valve bypass is not closed on the second test, check the pneumatic lines from the turbocharger compressor inlet and compressor outlet by forcing air through them.
2. If the engine surges, but the control seems to be operating properly when it was checked off the engine, examine the turbocharger compressor outlet line connection for leaks.

II -- REAR END SUSPENSION

SECTION A -- PURPOSE OF VEHICLE SUSPENSION

The main purpose of a vehicle suspension system is to: (1) support the weight, (2) attach the axles to the frame in proper alignment, (3) absorb brake reactive forces, (4) provide a means for the operator to steer (front only), and (5) provide for the absorption of road shocks.

This brief explanation of vehicle suspension will be centered around the rear end. Later we will go into much greater detail on both front and rear.

SECTION B -- TANDEM DRIVE AXLE SUSPENSION

Figure 16 shows a typical rear axle suspension system. This particular type system is called a semi-thrust block type spring mounting.

The tandem drive axles are mounted with semi-elliptical springs (4) and torque rods (8). The ends of each spring are securely clamped to the spring seats (6) which are pinned to the banjo housings (9). With this type mounting, the spring is also serving as torque rods used on the slipper end type spring mounting.

The center of each spring is clamped to the spring carrier (3) which is mounted in bushings in the frame and bogie plate. The ends of the spring carrier are free to turn in the bushing.

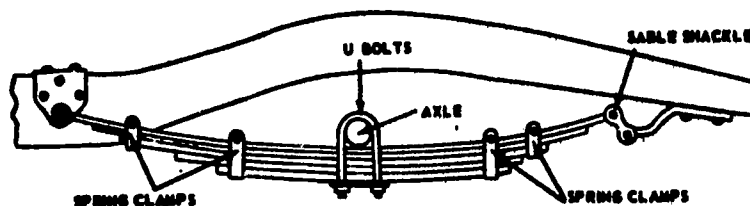

One end of each torque rod is pinned to a bogie plate while the opposite end is

Fig. 16 Leaf spring attached to rear axle of vehicle.

attached to an anchor plate welded on the axle housing. This type of mounting allows the drive axles to rise and fall and to oscillate. The rear axle may rise while the front axle goes down or vice versa, to allow for varying road conditions. However, the axles cannot twist or move sideways; their motion is restricted to either up or down movement.

WALKING BEAMS -- On some off-highway equipment, it is feasible to replace the springs (Figure 16) with what are known as walking beams. The walking beam is a solid piece of steel much the same shape as a layer of springs. The beam ties the two axles together in a tandem, and rotates in a vertical plane on a bushed pin attached to the frame bracket.

Reliability and less maintenance warrant using the walking beam in place of the springs. In addition more weight can be carried using this type of system.

SECTION C -- COMPRESSED NITROGEN CYLINDER SUSPENSION SYSTEM

Another type of suspension also used on very heavy off-highway equipment is the piston cylinder arrangement using compressed nitrogen. One such vehicle is the Le Tourneau-Westinghouse haulpak 120A rear dump hauler.

The big rear axle supports a piston which operates inside a frame-mounted cylinder. The cylinders' chambers support the load on compressed nitrogen gas, see Figure 17. The upper piston is normally kept in place by the pressure in the upper chamber. The lower piston and rod travel in the cylinder is dependent upon the load imposed. Whenever the main piston moves upward far enough to generate a pressure greater than that of the lower chamber, the inside piston reacts, thus providing a dual rate.

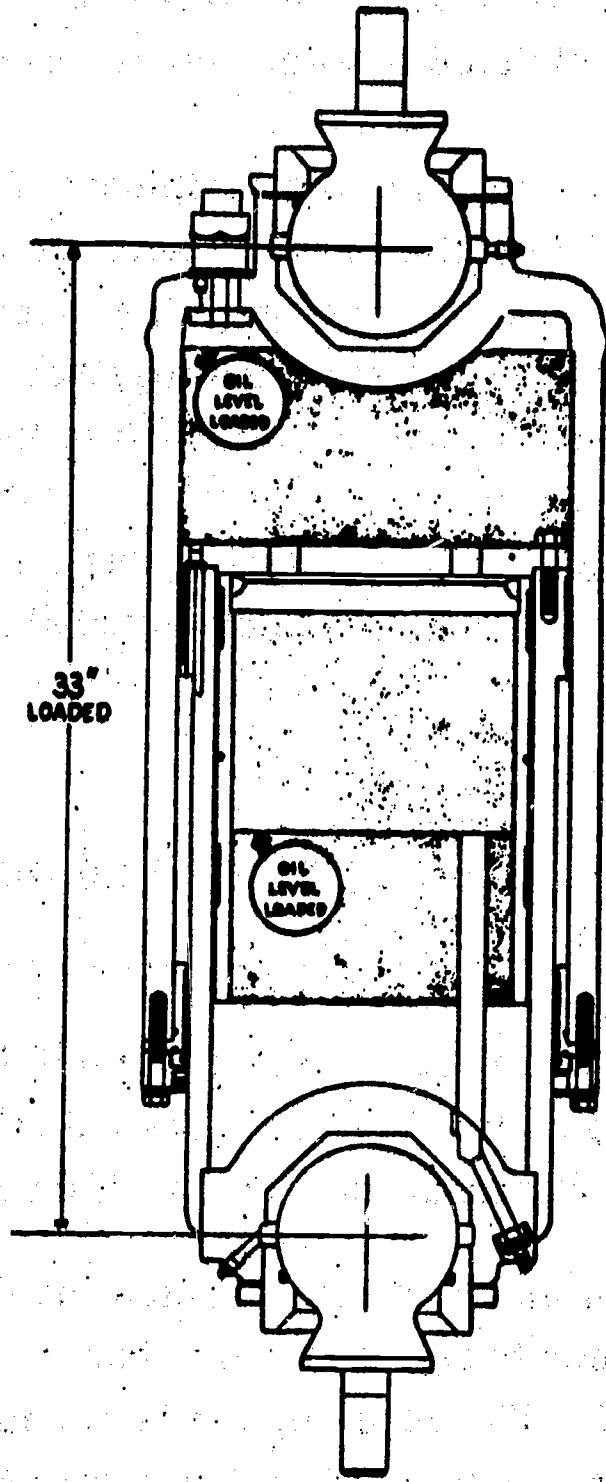

Fig. 17 Nitrogen suspension cylinder.

DIDACTOR PLATES FOR AM 1-21D

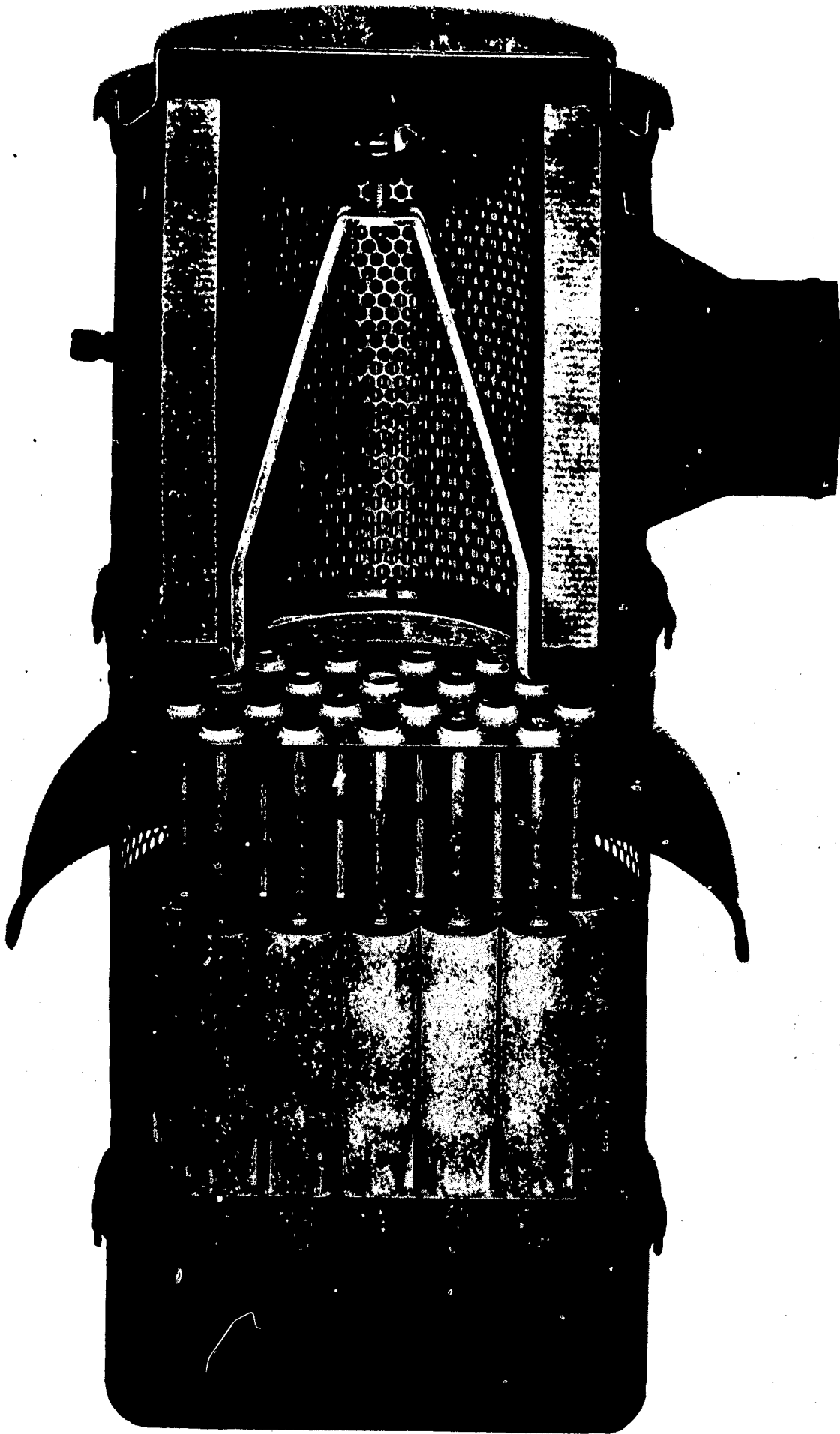
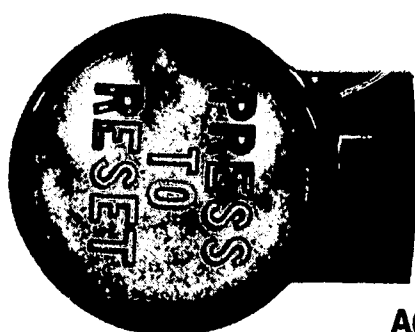
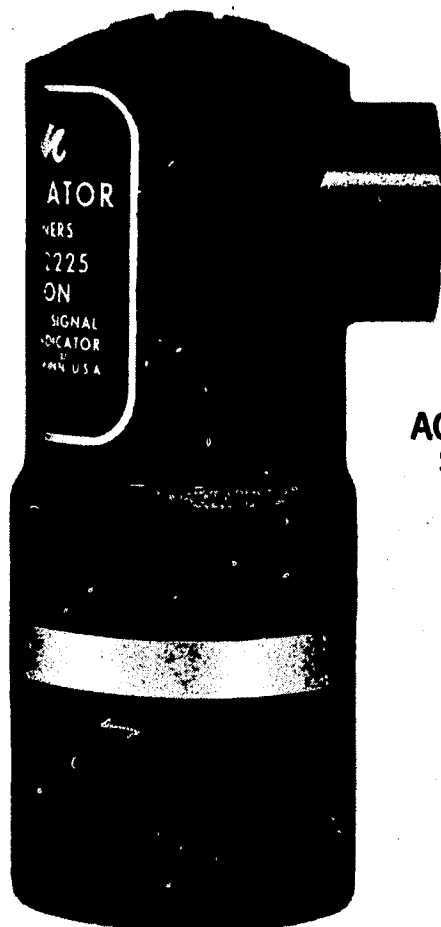

Plate I Donaclone dual dry filter



TOP VIEW

ACTUAL
SIZE



SIDE VIEW

ACTUAL
SIZE

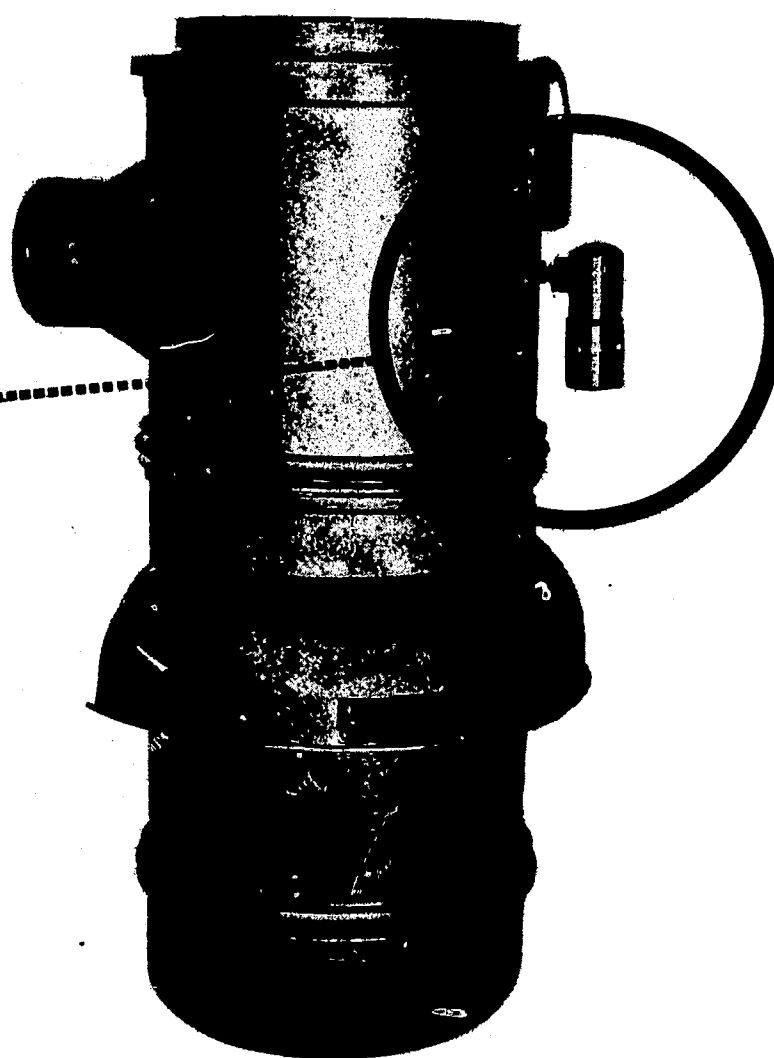

The above illustrates the direct mounting of a Donaldson Air Cleaner Service Gauge to the air cleaner.

Plate II Restriction indicator service gauge

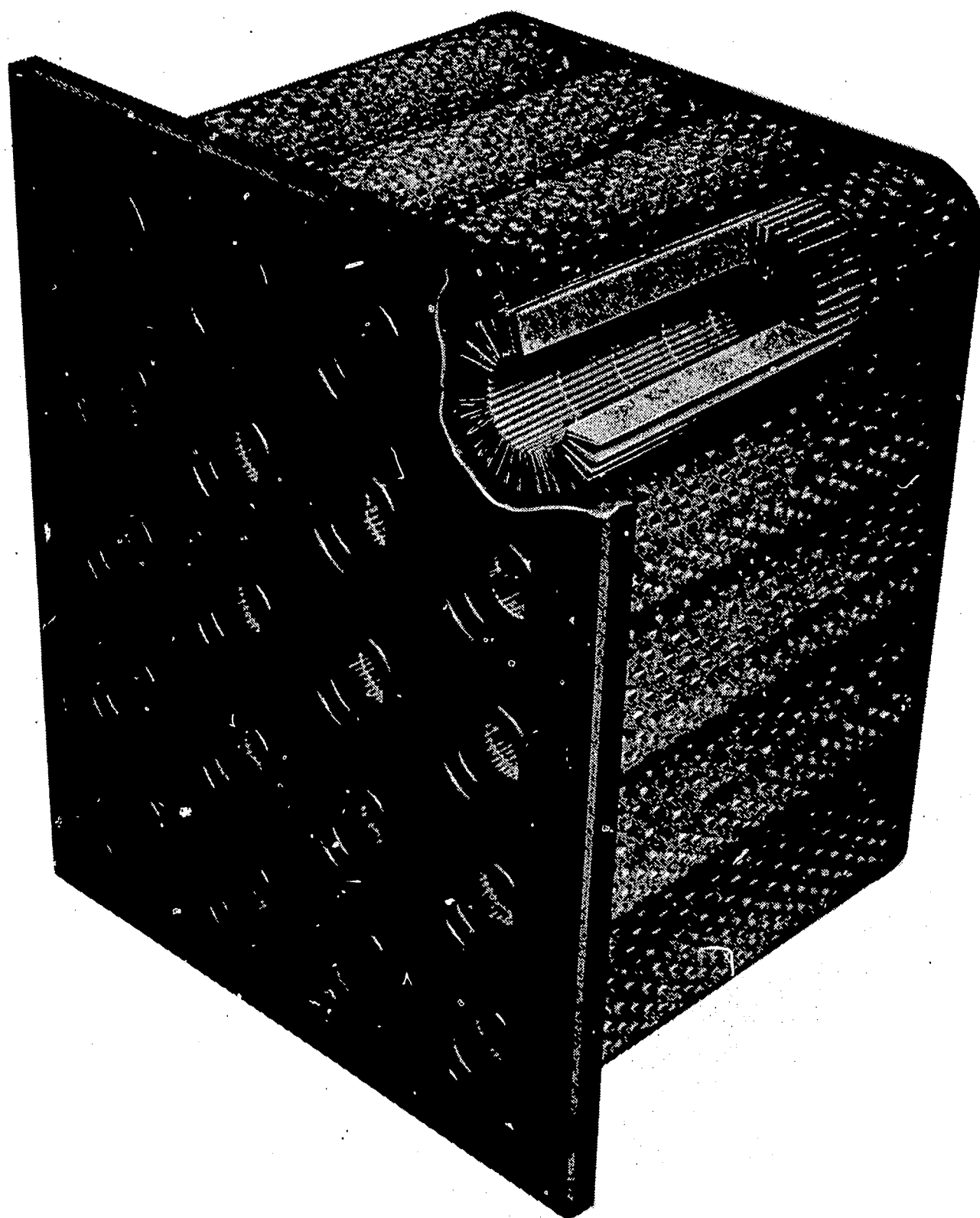

Plate III FARR filter cartridge

AM 1-21D
8-18-66

MAINTAINING THE AIR INTAKE AND EXHAUST SYSTEMS CATERPILLAR DIESEL ENGINE

Human Engineering - Minn. State Dept. of Ed.
Institute Vocational Education

Press A / Check to be sure that timer is OFF

In this lesson we will review some of the information previously covered on air intake and exhaust systems, including turbochargers, and add some new information to help you to better understand the principles involved.

The information covered in this section is on CATERPILLAR Diesel Engines, hereafter referred to as "Cat".

Press A 2

2

Basically, all diesel engine air systems are similar, and Cat engines are no exception. The air system serves to: filter the air, furnish adequate air needed for combustion, furnish additional air for scavenging (on two cycle engines) and to furnish air for turbocharged engines.

Cat engines are of the four cycle type using the naturally aspirated principle, except some engines are equipped with turbochargers. Turbocharged engines usually have two intake and two exhaust valves for each cylinder to aid engine breathing and incorporate the usual intake and exhaust manifolds.

Press A 3

3

Turbocharged Cat engines use the same basic principle as most diesel engines. One of the major differences is in the method of controlling the turbocharger speed, air pressure and volume, that will be covered later in this section.

Why does the turbocharger need a speed limiting device?

- 4 A. If allowed to run unchecked, it would cause the engine to overspeed and fly apart.
- 5 B. If allowed to run unchecked, the turbocharger itself may fly apart.
- 4 C. The excessive pressure built up in the intake manifold might crack the manifold, or worse yet, it may cause the engine to overheat.

4

No. You are incorrect.

If the turbocharger is allowed to run unchecked, it might fly apart.

The governor still controls the fuel to the engine, which in turn controls the engine speed, and the excessive pressure in the intake manifold would never reach a pressure high enough to crack the manifold or cause the engine to overheat.

Press A 5

5

OK. If the turbocharger was allowed to run unchecked it might fly apart at excessively high speed.

What effect does the "air pressure ratio control regulator" have on the speed of the Cat turbocharger?

- 6 A. None
- 6 B. It regulates the starting air pressure.
- 7 C. It regulates the air pressure, volume, and the speed of the turbocharger.

6

No. The air pressure ratio control regulator controls the air pressure, volume, and the speed of the turbocharger. It has nothing to do with the starting air.

Press A 7

7

OK. The "air pressure ratio control regulator" is almost self explanatory: It does just what it says, and also controls the turbocharger speed. The regulator control valve maintains the desired ratio between the turbocharger inlet air pressure and turbocharger compressor outlet pressure throughout the normal operating range of the engine.

How is the turbocharger speed controlled?

- 8 A. Similar to a speed limiting governor on an engine.
- 8 B. After a predetermined (pre-set) speed, a set of two rubbing blocks come into contact with the shaft area and slow the rotor to a safe speed.
- 9 C. The control mechanism limits the volume of exhaust gases passing through the turbocharger.

8

No. The control mechanism limits the volume of exhaust gases passing through the turbocharger, which in turn limits the speed. To slow the turbocharger and reduce the pressure boost, exhaust gases are directed around the turbocharger and then pass through the exhaust bypass tube to the exhaust elbow.

Press A 9

1

OK. The control mechanism simply directs some of the exhaust gases through the turbocharger, and some of the exhaust gases are directed around (bypass) the turbocharger.

Cummins engines are equipped with an "aneroid" valve, which controls the speed of the turbocharger by governing the fuel supply to the engine. The volume of exhaust gases from Cummins engines is controlled by the amount of fuel burned in the engine, in turn controlling the speed of the turbocharger.

Press A 11

XC 10

2

10

You have missed one or more of the questions at this point and should have an opportunity for review. Take your time and read the information over carefully.

Press A 3

2

11

As the engine starts, the flow of exhaust gases from the exhaust manifold is directed to the turbine wheel in the turbocharger. The exhaust bypass valve is closed at this time.

The power that drives the turbine wheel, which in turn drives the impeller, is obtained from the velocity and expansion of the _____.

- 12 A. incoming air
- 13 B. exhaust gases
- 12 C. pressure ratio control system

2

12

No. The power that drives the turbine rotor and impeller is not from the intake air or the pressure ratio control system. It is from the flow of exhaust gases from the exhaust manifold.

Press A 13

2

13

OK. As more fuel is injected into the Cat engine (fuel-air mixture), more energy is passed on to the exhaust gases. The turbine wheel speed is increased, and the impeller speed is increased the same amount (common shaft). Inlet manifold pressure increases in turn, forcing more air into the cylinders to support combustion for more fuel. This process allows more horsepower to be developed by the addition of the turbocharger.

Press A 14

2

14

What effect, if any, will an increase in engine speed have on the turbocharger?

- 15 A. None whatsoever; the turbocharger speed is controlled by the pressure ratio control system.
- 16 B. As engine speed increases, so will the turbocharger, to a pre-set point.
- 15 C. Turbocharger speed will depend entirely on the load on the engine.

2

15

No. The turbocharger speed is controlled by the pressure ratio control system, but it must get up to a pre-determined (pre-set) speed before it starts to govern the turbocharger speed, and light or no load on the engine has little or no effect on the speed of the turbocharger. We can correctly say, "as engine speed increases, so will turbocharger speed increase," to the pre-determined speed setting.

As was mentioned before, the pressure ratio control valve simply directs some of the exhaust gases through the turbocharger and some around it.

Press A 16

2

16
OK. The effect of increased engine speed has a definite effect on turbocharger speed, until the intake manifold pressure reaches a pre-determined value. At this pre-determined setting the pressure ratio control valve starts to bypass some of the exhaust gases around the turbocharger, and in turn governs its speed.

Press A 17

2

17
The pressure ratio control system uses a pneumatically (air) operated pressure ratio control regulator to maintain the desired ratio between the turbocharger inlet air pressure and turbocharger compressor outlet pressure throughout the normal operating range of the engine.

The control mechanism maintains the ratio by limiting the volume of exhaust gases passing through the turbocharger turbine, which in turn controls the maximum speed of the turbocharger compressor.

What position would the pressure ratio control valve be in during engine start?

- 18 A. Fully open. (Bypass)
- 19 B. Fully closed.
- 18 C. Half-open and half-closed.

2

18
No. In the fully bypassed position (open), little or no exhaust gases would go through the turbocharger turbine and, instead of contributing to the output and performance of the engine, the turbocharger would create resistance and loss of power.

The control valve would not be in the half-open position either. This would happen only during high speed and heavy load conditions under normal conditions.

The correct answer is: the pressure ratio control valve would be in the fully closed position during engine start. Read the questions carefully; take your time in selecting an answer.

Press A 19

2

19
OK. You are correct, the valve would be in the closed position during engine start.

The turbocharger impeller turns as a result of the exhaust gas velocity acting on the turbine wheel; the result is a buildup of pressure in the inlet manifold, which in turn is one of the forces acting on the pressure ratio control valve. The other pressure acting on the control valve is the inlet pressure, ahead of the impeller. What effect, if any, would a restricted intake air system (dirty air cleaner etc.) have on the engine?

- 20 A. None whatsoever.
- 21 B. Loss of power and smoky exhaust.
- 20 C. Engine would tend to overspeed.

2

20
No. A restricted intake air system would definitely have an effect on the engine. The first noticeable effect would be the smoky exhaust, due to insufficient air to support combustion, and the next would be the loss of power. It is very unlikely that the engine would overspeed.

Press A 21

2

21
OK. We have mentioned turbochargers and superchargers on other engine installations such as Cummins. We have also mentioned the effects of compressing the air above atmospheric pressure and the increase in temperature from being compressed. The Cat engine is no exception; it must have some means of cooling the air from the turbocharger to the engine. A water cooled heat exchanger, or after-cooler is provided on Cat engines.

Press A 22

2

22
What effect, besides cooling, does the after-cooler have on the air and the operation of the engine?

- 23 A. Allows the engine to be run in hotter weather.
- 23 B. The cooled air is more dense and more air can be packed into the engine.
- 24 C. The after-cooler acts as a heater in cold weather and contributes to the engine's efficiency, plus the information in "B".

2

23
No. The after-cooler is not for the purpose of running the engine in hot weather, but contributes to efficient operation of the engine in either cold or hot weather. The hot air that is cooled by the after-cooler is more dense after cooling and more pounds of air can be packed into the engine cylinders to support combustion of more fuel and develop more horsepower. The warming of the air in winter does contribute to the efficiency of the engine, by warming the cold intake air.

Both: the warming in cold weather, and cooling in warm weather, contribute to a more efficient (better combustion) running engine.

Press A 24

2

24

OK. It is true the after-cooler contributes to the engine's efficiency in either cold or hot weather.

The Cat engine is unique compared to other engines, in that the Cat has a built-in cold weather starting aid. An exhaust tube from the two cylinder gasoline (pony engine) starting engine runs the entire length of the intake manifold for the diesel engine. (See Unit AM 1-21 for diagram). The hot gases from the pony engine preheat the intake manifold of the diesel engine and contribute to relatively easy starting in cold weather.

Press A 25

2

25

We have mentioned the effects of heat and cold, as affected by the after-cooler and other cold weather starting aids. We haven't mentioned the effects of altitude, and how the density of the air changes at different levels of altitude. Some engine manufacturers refer to their turbocharger as an altitude compensator. It supposedly adjusts for the change in altitude automatically.

Press A 26

2

26

How does the Cat engine turbocharger compensate for the change in altitude?

- 27 A. The priority valve automatically changes the direction of exhaust gas to the turbine rotor as altitude increases.
- 28 B. The air pressure ratio control regulator allows less exhaust gases to pass through the turbine rotor, and more to be bypassed as altitude and load increases.
- 27 C. Altitude has no adverse effect on Cat engines with or without turbochargers.

2

27

No. The Cat engine turbocharger does compensate for the changes in altitude, and without the aid of a turbocharger the engine would suffer loss of horsepower as altitude increases.

As altitude increases, the turbocharger turbine rotor speed would also increase if some provisions were not made to limit it. The nozzle, which directs the hot gases onto the turbine blades, also affects the turbocharger speed. The thin air at high altitudes requires less energy to turn the rotor, and the nozzle size determines how much force the exhaust gases impart to the turbine.

Press A 28

2

28

OK. The maximum altitude at which the Cat engine can be operated is specified on the altitude warning plate located on the valve cover or instrument panel. Changes to turbocharger, rack setting, or high idle speed should be made only by authorized personnel.

What possible effect would changes in altitude have if improper adjustments were made on high idle speed or fuel rack setting?

- 28 1/2 A. Cat engines equipped with turbochargers would not be affected.
- 30 B. If the high idle speed or the rack setting is greater than specified for the altitude at which the engine is operated, serious damage to the engine or turbocharger parts may result.

XC 29

3

28 1/2

No. As we mentioned before, the rack setting, or high idle speed, should be changed only by authorized personnel. There is a definite requirement that this setting be in relation to the altitude; otherwise the turbocharger may overspeed along with the engine, causing damage to both.

Press A 30

3

29

You have missed one or more questions in this section and you should have the opportunity to go back for a review of the last few frames. Read the information over carefully and take your time in selecting an answer.

Press A 11

3

30

OK. The answer given is correct, but it should be remembered that any changes made should be stamped on the altitude warning plate and should be made only by authorized personnel.

Like any other carefully made equipment manufactured with close tolerances, the turbocharger requires periodic maintenance to provide maximum performance and maximum service life. The maintenance can be summed up by one word --

- 31 A. carefulness
- 31 B. carelessness
- 32 C. cleanliness

3

31

The one word in this case is Cleanliness, involving one gallon of water and a cup of low sudsing detergent. Check the Caterpillar maintenance manual for this cleaning procedure.

Press A 32

3

32

OK. Cleanliness is correct, and it is simple, with a gallon of water and a cup of low sudsing detergent. Check the Caterpillar maintenance manual for this procedure.

The turbocharger rotating assembly, consisting of the impeller, the turbine and their common shaft, is the heart of the turbocharger. These parts are designed and built to operate at extremely high speeds; 50,000 rpm often is encountered in normal operation. At such high speeds, balance is of utmost importance. A very slight unbalance shows up at high speeds as an extremely great force trying to bend the shaft.

Press A 33

3

33

As we have mentioned before, maintenance can be summed up by one word Cleanliness. Cleanliness begins with the diesel engine air cleaner. Dust and dirt that would cause wear on the interior of the engine would also be harmful to the turbocharger. Although the air cleaner is efficient in removing dust and dirt from the air that is taken into the engine, some dirt may pass through the air cleaner screens and form a thin deposit on the impeller. What effect if any would the dirt deposits on the impeller have?

- 34 A. None.
- 34 B. Slow it down from turning the required speed.
- 35 C. It would cause an unbalanced condition.

3

34

No. If the dirt deposits were uniform it would have little affect on the dynamic balance of the rotating assembly. But, if particles flake off, the rotating assembly will run out of balance. This unbalance, however small, will impose a terrific load on the bearings at the speeds near 50,000 rev. ions per minute. Therefore, it is important that the deposits be removed periodically, to keep the rotating assembly in balance and prolong turbocharger life.

Press A 35

3

35

OK. It would definitely cause an unbalanced condition.

Cleanliness of the lubricating oil also plays an important part in turbocharger life. How are most Cat turbochargers lubricated?

- 36 A. Cat turbochargers have their own oil reservoir.
- 37 B. Cat turbochargers are lubricated from the engine's crankcase.
- 36 C. Cat turbochargers have sealed bearings that are packed at the factory and require little maintenance.

3

36

No. Cat turbochargers do not have their own oil supplies -- due to the high probability of being neglected, and they do not have sealed bearings. Sealed bearings would tend to retain the heat rather than get rid of it, (dissipate it). Cat turbochargers are lubricated from the engine lubricating system.

Press A 37

3

37

OK. Cat turbochargers are lubricated from the engine lubrication system.

Air Cleaners -- Much has been said about air cleaners in past Units and films. Cat engines use basically the same type as do GM and Cummins engines. There is one air cleaner we haven't mentioned, that is rapidly becoming more widely used than the conventional type. This is the FARR square type air cleaner that has a replaceable pleated paper type filter element. A unique and very effective characteristic of this air cleaner is the aspirator attachment that is optional equipment on the two stage model.

Press A 38

3

38

Figure 6 in Unit AM 1-21 shows the flow of air through the filter. As air enters the pre-cleaner panel at a fast pace, it is swirled rapidly by the fins located in the face of the pre-cleaner. This spinning of the air by centrifugal force removes (1) _____ of the dust particles down to (2) _____ to (3) _____ micron size leaving all particles below that size to be trapped by the paper filters. (See Plate III).

- 39 A. (1) 60% (2) 90 (3) 100
- 40 B. (1) 90% (2) 5 (3) 10
- 39 C. (1) 50% (2) 25 (3) 40

3

39

No. The spinning of the air removes about 90 percent of the dust particles down to 5 to 10 micron size which is trapped in the filter paper.

Press A 40

3

OK. The dust particles removed by spinning drop into a dust bin where they are removed through a metal flex hose into the aspirator and out with the exhaust.

What principle is involved in drawing the dust particles from the dust pan into the exhaust system?

- A. High back pressure.
- 42 B. Vacuum and venturi principle.

Only the correct answer will move you to the next frame.

XC 41

3

41

No. You have missed one or more questions in the past section and should have an opportunity to go back for a review. Take your time, and read the information carefully.

Press A 32

3

OK. The venturi principle is used to remove dust and dirt particles from the dust pan. A low pressure (vacuum) area is created by the exhaust gases going from a larger area to a small area, very much like the effect of the air fuel mixture being drawn into the manifold of a gasoline engine, and creating a low pressure area in the venturi section of a carburetor.

FARR and some other air cleaners have indicators to indicate restriction caused by the progressive build-up of dirt and dust. They are usually referred to as "air cleaner restriction service gauges".

Press A 43

4

43

Another device that is being used by several engine manufacturers is the "Vacuator" sometimes called the "Sneezer". The "vacuator" valve is made of rubber and fits on a cylindrical steel dust and water reservoir. Even though the dust pan is normally under a slight vacuum when the engine is running, pulsing of the vacuum opens and closes the valve, expelling dust and water. The valve will also unload when the engine is stopped.

There are several different types of air cleaners, some better than others. Check the service manual for the type installed on the equipment you are servicing.

Press A 44

4

There is little need to repeat the principles of operation of the Cat engine as compared to other engines. The construction is the main difference, and some of the unique changes made in recent years are worth mentioning. One such change is the valve rotor, Figure 11, in Unit AM 1-21. This mechanism rotates the valve approximately 3° each time the valve is opened.

Why are valve rotors installed on Cat engines?

- 45 A. To prevent the valve from sticking in the valve guide.
- 45 B. To prevent the valve from seating in the same spot each time it opens and preventing burning of valve disc.
- 46 C. Valve rotation results in more uniform valve head temperature plus "A & B".

4

45

No. The valve rotor is installed in Cat engines for more uniform valve-head temperature, to prevent cylinder and combustion space deposits from building up under the valve and seat and burning the valve disc.

Press A 46

4

46

OK. The valve rotor is to prevent damage to the valve and seat mechanism by having them seat at a different spot each time the valve opens. Is it possible to determine if the valves are rotating during engine operation?

- 47 A. It is not possible to determine if the valves are rotating due to the engine being covered.
- 48 B. It is possible to determine whether the valve is rotating by removing the valve cover and watching the serrations on the top of the valve spring retainer.
- 47 C. It makes little or no difference if you can observe the valve stems, the rotation is so fast you cannot see it anyway.

4

47

No. To determine whether a valve rotor is operating, observe the serrations on top of the valve spring retainer. If the serrations do not rotate during operation, replace the valve rotor as a unit.

Press A 48

4

48

OK. There are two camshafts on the "A" & "B" Series Cat engines. The camshafts are side by side; see Figure 14 in Unit AM 1-21.

How are the double overhead camshafts driven on the "A" and "B" series Cat engines?

- 49 A. The camshafts in Cat "A" and "B" series engines are driven by sprocket chains.
- 49 B. The camshafts are driven by phasing gears.
- 50 C. The exhaust camshaft is driven through the cam drive shaft and the inlet is driven through the cam phasing gears.

4

49

No. The exhaust camshaft is connected to the camshaft drive gear by the cam drive shaft. The inlet camshaft is driven by the exhaust camshaft through the phasing gears located at the front of the camshaft assembly. No chains are used on this application.

Press A 50

4

50

OK. Since there are no rocker arms or push rods, the Cat engine has a unique way of adjusting the valve lash (valve clearance). The valves are operated directly by the cam lobes on the Cat dual-overhead cam engines. (See Figure 11 in Unit AM 1-21).

The valve lash (valve clearance) is adjusted with _____

- A. two half inch open end wrenches and a thickness feeler gauge
- 52 B. one #2 phillips screwdriver and a feeler gauge

(The correct answer must be chosen before moving on to the next frame).

xc 51

4

51

No. You have missed one or more questions in this group and should have an opportunity for a review. Read the questions ever carefully, and take your time in selecting an answer.

Press A 44

4

52

OK. Figures 11 and 12 in Unit AM 1-21 show details of adjusting the compression release and the valve lash (valve clearance). When is the compression release normally used?

- 53 A. The compression release is normally used when stopping the engine.
- 54 B. The compression release is normally used when starting the engine.
- 53 C. It is used only when working on the engine, cranking it over by hand etc.

5

53

No. The compression release is normally used when starting the engine, to release the cylinder compression pressure which allows the engine to get up to a speed where starting would be possible, without undue load on the cranking motor, or starting engine.

At times, the compression release is used when working on the engine, but this is not its intended purpose. The compression release should never be used to stop the engine, except in case of emergency, since damage to the engine may occur.

Press A 54

5

54

OK. The compression release is used primarily as a starting aid, and should never be used to stop the engine, except in case of emergency, since damage to the engine may occur.

The compression release is also used to release the compression pressure built up when cranking the engine over by hand, but this was not its intended purpose.

Press A 55

5

55
It is not the intention of this Unit to get into the Cat lubrication system. However, since this particular valve involves the turbocharger and the intake and exhaust system, it will be covered briefly.

Cat engines equipped with turbochargers have what is called a "priority valve". The purpose of this valve is to _____.

- 56 A. show which lubrication strainer has priority for use
- 56 B. show which fuel filter and strainer has priority
- 57 C. neither of the above. It restricts the flow of lubrication oil to other parts of the engine until the turbocharger gets the proper amount of lubrication upon starting

5

56
No. The priority valve, as it is sometimes called, is the turbocharger lubrication valve built into the base of the lubricating oil filter. It allows the first bit of lubricating oil that is pumped to go directly to the turbocharger bearings, instead of through the cooler and filter, as it normally does after the engine runs a few minutes. The function of the priority valve is to ensure lubrication to the bearings immediately, to prevent possible damage to the turbocharger bearings.

Press A 57

5

57
No. The priority valve is used to ensure an adequate oil supply to the turbocharger bearings immediately after starting the engine. More will be said about this valve in the lubrication section.

Press A 58

5

58
The main purpose of a vehicle suspension system is to:

1. Support the weight.
2. Attach the axles to the frame in proper alignment.
3. Absorb brake reactive forces.
4. Provide a means for the operator to steer (front only).
5. Provide for the absorption of road shocks.

This brief explanation of vehicle suspension will be centered around the rear end. Later, much greater detail on both front and rear suspension systems will be covered.

Press A 59

5

59
The parts of suspension systems common to most types of vehicles or equipment are axles, springs (laminated and/or coil), torsion bars, wheels and tracks. What new type of suspension system is coming into use on many vehicles?

- 60 A. The ideal spring system.
- 60 B. The rapid recovery spring.
- 61 C. Air suspension.

5

60
No. We don't know of any such spring as the rapid recovery or the ideal, but air suspension systems are becoming more popular, even on buses and heavy equipment.

Press A 61

5

61
OK. Air suspension systems are coming into use more and more. On some vehicles a few manufacturers have gone to a different type of suspension system. One such vehicle is the Le Tourneau Westinghouse Haulpak 120A rear dump hauler. What type of suspension system does the above mentioned vehicle use?

- 62 A. Compressed air bag type.
- 63 B. Compressed nitrogen gas piston/cylinder arrangement.
- 62 C. Compressed CO₂ for the cooling effect, and piston/cylinder arrangement.

5

62
No. Compressed air bags are used on some types of vehicles, but not as a suspension system, for shock absorber and load leveler. Compressed CO₂ is not the gas used for its cooling effect. The suspension system used on the Haulpak 120A is the compressed nitrogen gas piston/cylinder arrangement.

Press A 63

5

63

63 1/2

OK. The compressed nitrogen gas piston/cylinder arrangement is the system used on the Haulpak 120A. See Figure 19, in Unit AM 1-21 for details.

You have missed one or more of the last few questions. Read this over again and take your time in answering.

Press A 64
XC - 63 1/2

Press A 52

6

6

64

65

As promised, we will review some of the information previously covered on air intake and exhaust systems. In this section we will cover the Donaldson type air cleaners, the different types and uses employed on Cat and comparable equipment.

No, it is not an oil bath or just plain centrifugal type. It is a dual all-dry centrifugal and paper element type. It is particularly recommended where heavy dust concentrations are encountered, as on rock crushers, in asphalt plants, and on crawler tractors and earth moving operations.

The Donacclone SDG series air cleaner is what type air cleaner?

- 65 A. An oil bath type.
- 65 B. A centrifugal type.
- 66 C. A dual all-dry centrifugal and paper type.

Press A 66

5

6

66

67

OK. The Donaldson "Donacclone" employs a dual dry system, combining a centrifugal clearing stage of high efficiency with a specially engineered paper filter. See Plate I. The paper filter porosity is closely controlled to remove particles in the extremely low _____

No. Not in the low dust or filtering range, but in the low micron (small size) range. This is accomplished by use of the Donaldson Duralife filter element.

- 67 A. filtering area
- 67 B. dust range
- 68 C. micron range

Press A 68

6

6

68

69

OK. Low micron (small size) range is correct. The Donacclone tube also plays an important part in the filtering action of the filter assembly. The "donacclone" tube is made of abrasion-resistant nylon. Vanes at the top give a cyclonic twist to the air, which throws dust particles to the outside. Clean air at the center passes up through the aluminum tube to the Duralife paper filter element for further filtering. See Plate I.

The air cleaner should be inspected constantly for leaks. A damaged air cleaner can seriously affect the performance and life of an engine. Some simple service steps are as follows:

1. Watch all connections for mechanical tightness. Be sure the cleaner outlet pipe is not fractured.
2. If cleaner has been dented or damaged, check all connections immediately.
3. In case of leakage, and if adjustment does not correct the trouble, replace parts as necessary.

Press A 69

Press A 70

6

6

70

How can filter cartridge leaks be detected?

- 71 A. By removing a section of the intake manifold and checking for dust and dirt particles.
- 71 B. By taking samples of air as it leaves the filter.
- 72 C. By noting areas of dust on the clean side of cartridge, and light shining through holes when light is held inside of cartridge.

6

71

No. It may be impractical to remove the intake manifold, and it may also be impractical to take a sample of air as it leaves the filter for analysis. The best indications of leaks are dust concentration areas on the clean side of the cartridge and light shining through holes from inside of the filter cartridge.

Press A 72

6

72

OK. It is recommended by the manufacturer that the paper filter element, (duralife) can be washed in a solution of water and cleaning detergent. According to the FARR company, however, their filter element is designed for one service period only. What is one of the best methods of determining when the filter elements need attention?

- 73 A. Visual inspection of the element.
- 73 B. Engine starting to smoke because of the increase in air intake restriction.
- 74 C. A filter service indicator or filter service gauge.

6

73

No. The filter should be serviced long before the engine starts to smoke excessively. One of the best methods of determining when the filter needs attention is by a filter service indicator. This indicator shows the change in air restriction as dirt deposits build up in the filter. As the filter restriction increases, the signal rises within the indicator. When the preset maximum is reached, the signal locks in full view to indicate the need for service.

Press A 74

6

74

OK. The filter service indicator is one of the best ways of determining when a filter needs attention before something serious happens to the engine. (See Plate II).

That completes this film. More information will be covered on these subjects in later sections.

Please press the REWIND button.

6

AM 1-21

①

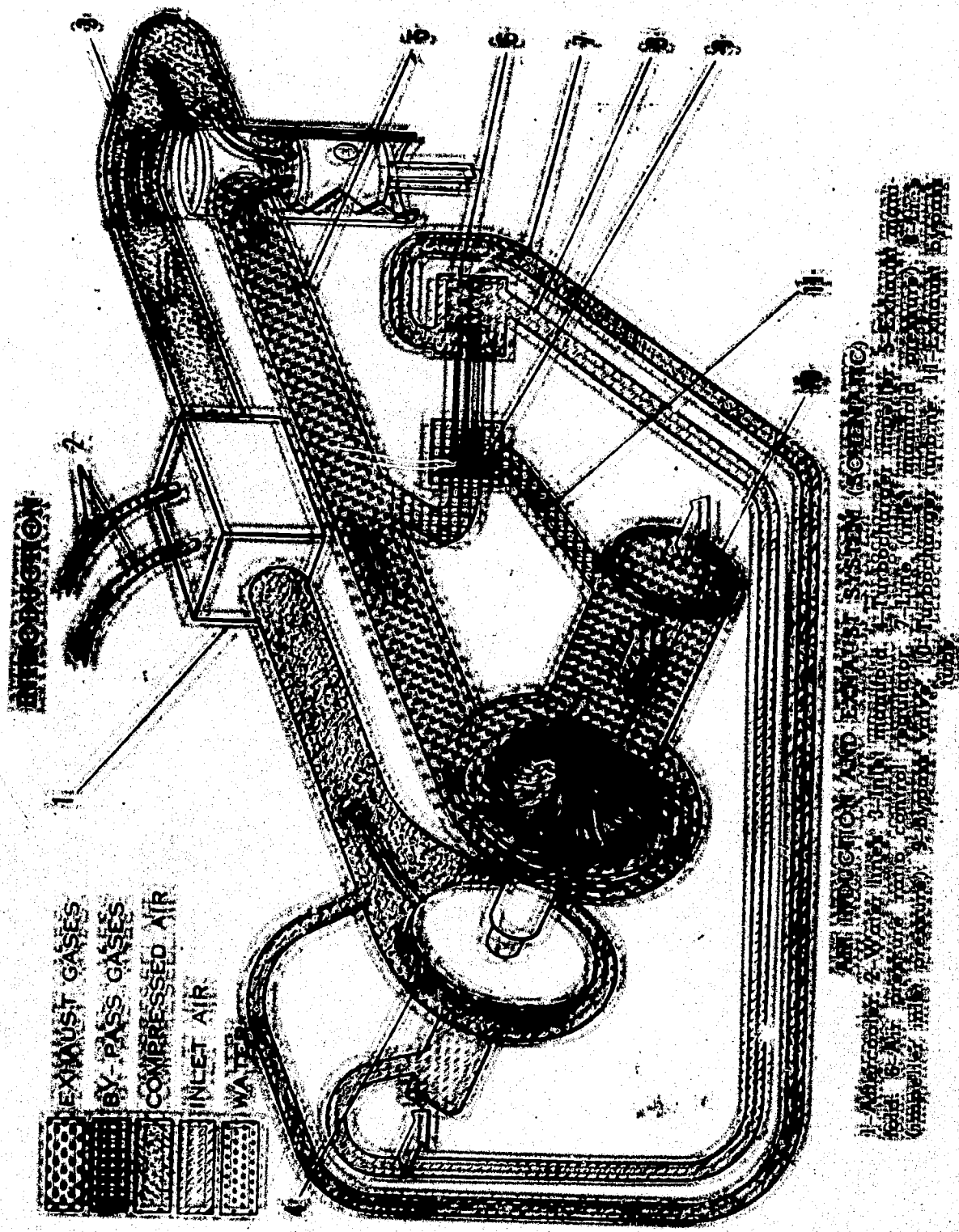

HUMAN
ENGINEERING
INSTITUTE

2141 Carnegie Ave.
Cleveland Ohio 44115



(R)

EXECUTIVE DEVELOPMENT • PERSONNEL TESTING • CAREER PLANNING

FIG. 1

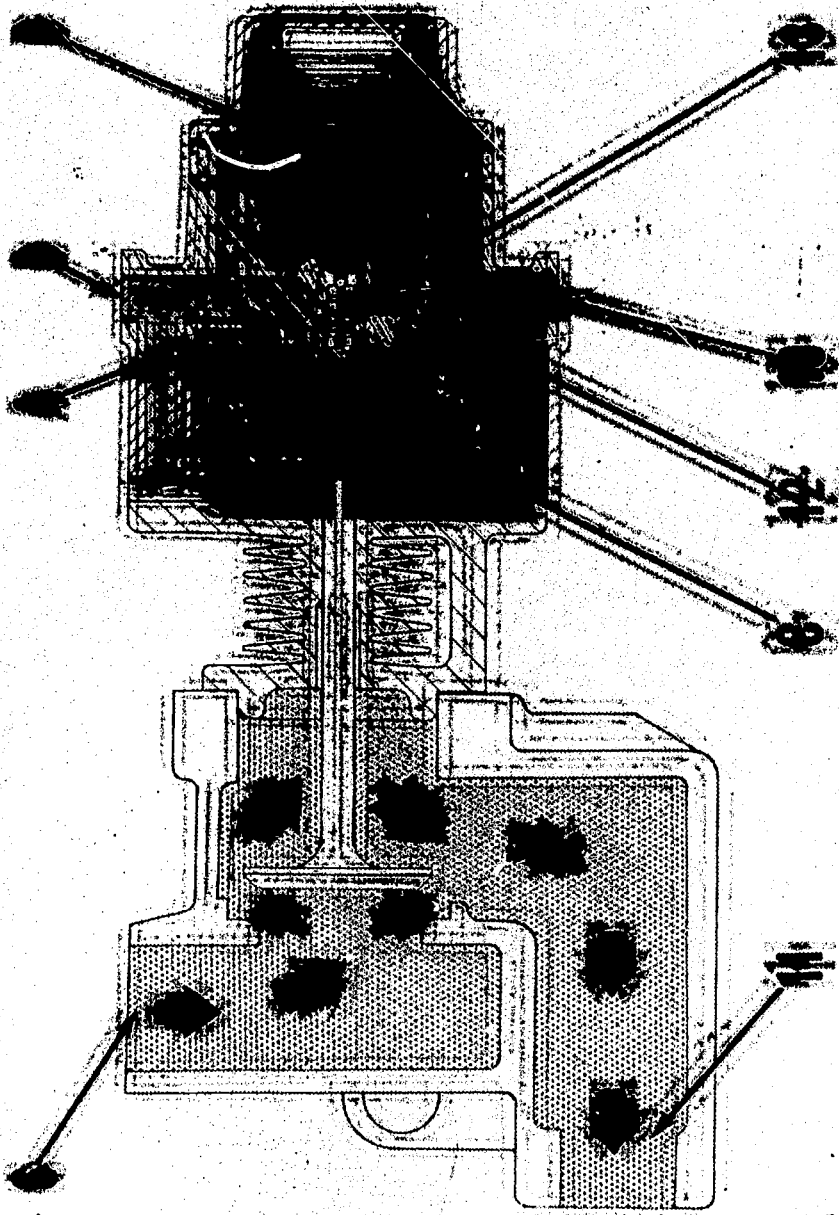

**PRESSURE RATIO REGULATOR OPERATION
(BYPASS VALVE OPEN)**

6-From exhaust manifold. 8-Pressure line (turbocharger compressor inlet). 10-Pressure line (turbocharger compressor outlet). 11-Exhaust piping. 12-Orifice. 13-Poppet valve. A-Cavity. B-Diaphragm. C-Diaphragm.

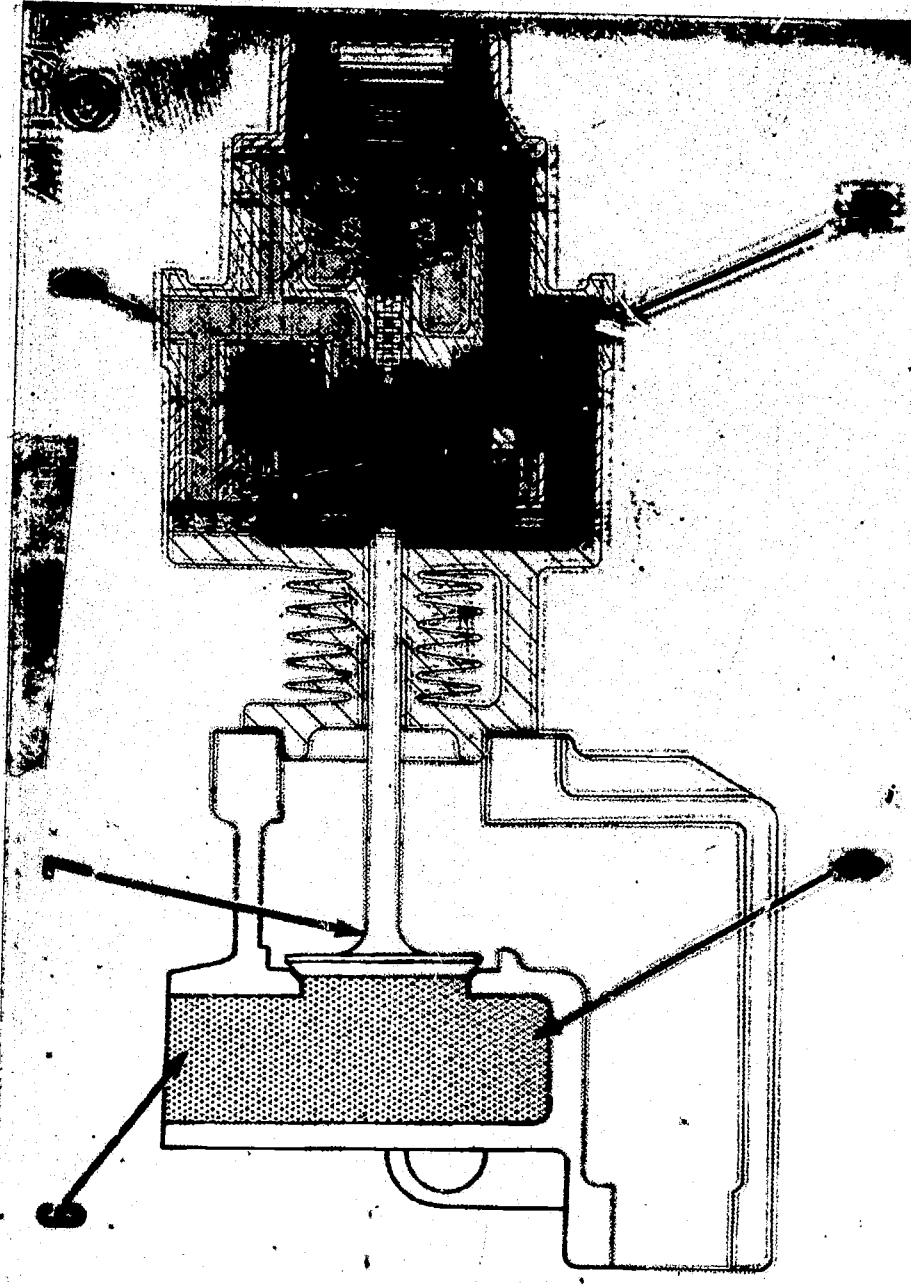

**PRESSURE RATIO REGULATOR OPERATION
(BYPASS VALVE CLOSED)**

6-From exhaust manifold. 7-Bypass Valve. 8-Pressure line connection (turbocharger compressor inlet). 9-Exhaust gases. 10-Pressure line connection (turbocharger compressor outlet).

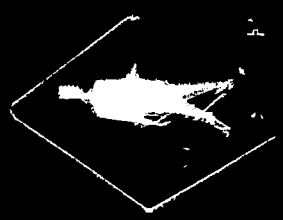

AMERICAN

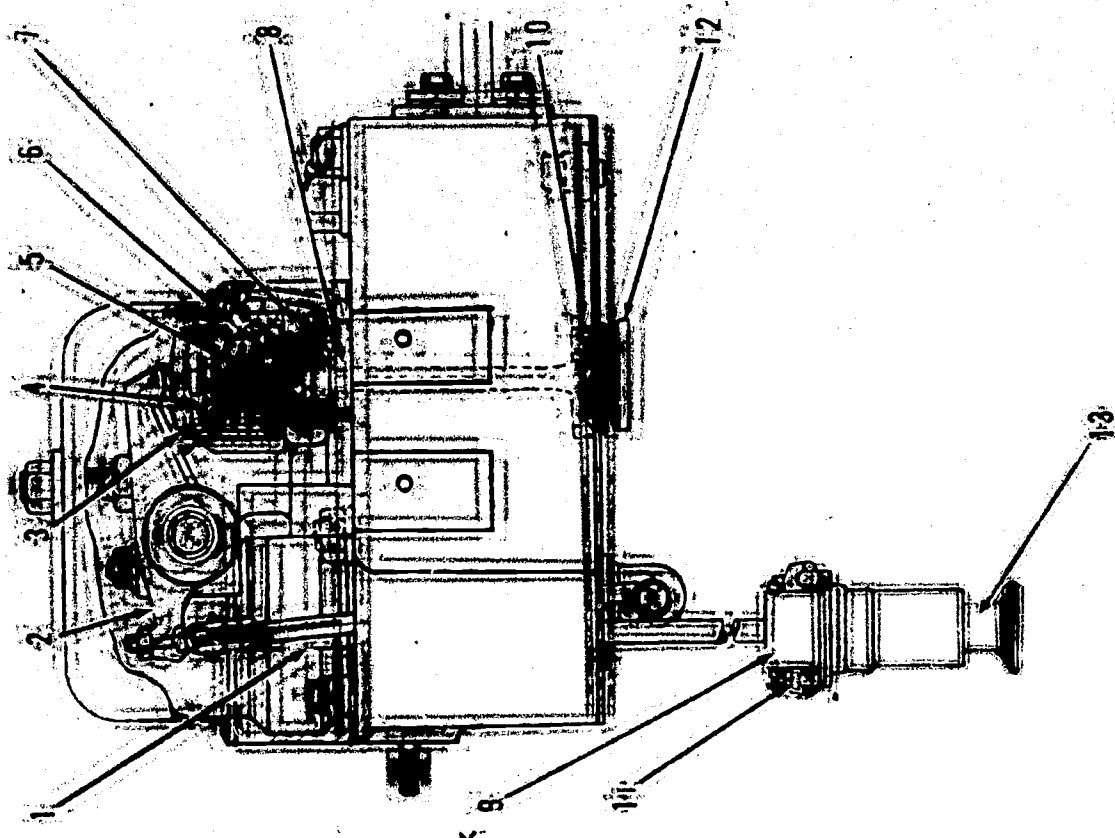

VALVES AND VALVE MECHANISM

1-Push rod. 2-Rocker arm. 3-Slide. 4-Valve. 5-Valve spring. 6-Outer spring. 7-Rocker. 8-Valve stem. 9-Valve lifter guide. 10-Block. 11-Valve. 12-Valve. 13-Valve lifter.



**HUMAN
ENGINEERING
INSTITUTE**

1500 Carnegie Ave.
Columbus, Ohio 43115

AM 1-21

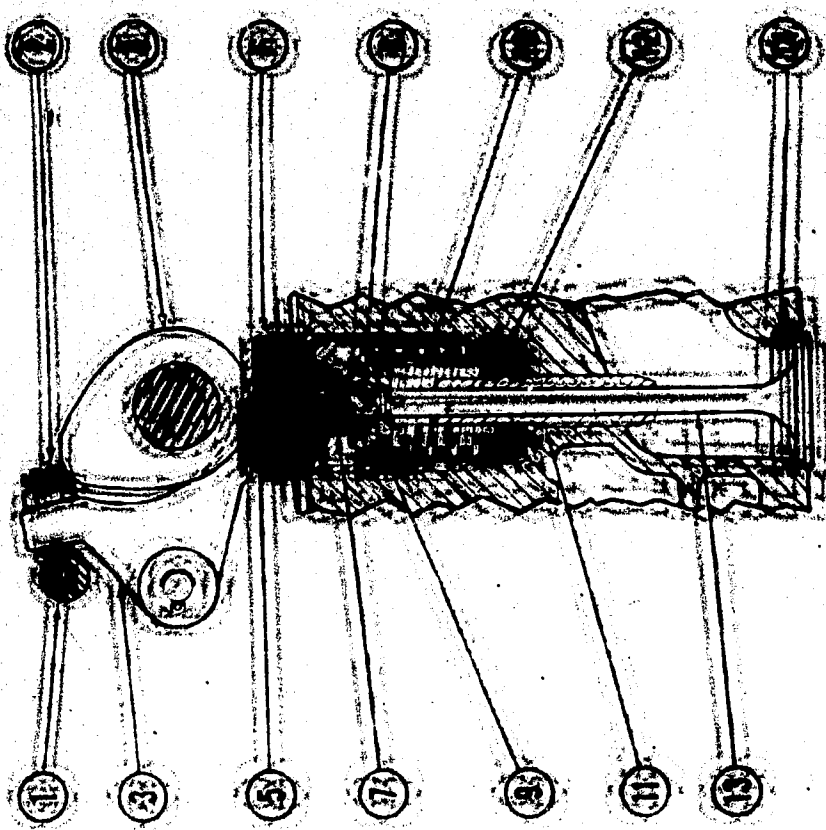

VALVE MECHANISM

- 1-Compression release
- 2-Compression release
- 3-Compression release
- 4-Compression release
- 5-Compression release
- 6-Compression release
- 7-Compression release
- 8-Compression release
- 9-Compression release
- 10-Compression release
- 11-Compression release
- 12-Compression release
- 13-Compression release
- 14-Compression release



HUMAN ENGINEERING INSTITUTE

2141 Carnegie Ave
Cleveland OH 44115



AMERICAN

WAVE, WITH FLUENT
H. Campbell, 2, 3, 4, 5, 6, 7, 8, 9, 10, 11, 12, 13, 14, 15, 16, 17, 18, 19, 20, 21, 22, 23, 24, 25, 26, 27, 28, 29, 30, 31, 32, 33, 34, 35, 36, 37, 38, 39, 40, 41, 42, 43, 44, 45, 46, 47, 48, 49, 50, 51, 52, 53, 54, 55, 56, 57, 58, 59, 60, 61, 62, 63, 64, 65, 66, 67, 68, 69, 70, 71, 72, 73, 74, 75, 76, 77, 78, 79, 80, 81, 82, 83, 84, 85, 86, 87, 88, 89, 90, 91, 92, 93, 94, 95, 96, 97, 98, 99, 100, 101, 102, 103, 104, 105, 106, 107, 108, 109, 110, 111, 112, 113, 114, 115, 116, 117, 118, 119, 120, 121, 122, 123, 124, 125, 126, 127, 128, 129, 130, 131, 132, 133, 134, 135, 136, 137, 138, 139, 140, 141, 142, 143, 144, 145, 146, 147, 148, 149, 150, 151, 152, 153, 154, 155, 156, 157, 158, 159, 160, 161, 162, 163, 164, 165, 166, 167, 168, 169, 170, 171, 172, 173, 174, 175, 176, 177, 178, 179, 180, 181, 182, 183, 184, 185, 186, 187, 188, 189, 190, 191, 192, 193, 194, 195, 196, 197, 198, 199, 200, 201, 202, 203, 204, 205, 206, 207, 208, 209, 210, 211, 212, 213, 214, 215, 216, 217, 218, 219, 220, 221, 222, 223, 224, 225, 226, 227, 228, 229, 230, 231, 232, 233, 234, 235, 236, 237, 238, 239, 240, 241, 242, 243, 244, 245, 246, 247, 248, 249, 250, 251, 252, 253, 254, 255, 256, 257, 258, 259, 260, 261, 262, 263, 264, 265, 266, 267, 268, 269, 270, 271, 272, 273, 274, 275, 276, 277, 278, 279, 280, 281, 282, 283, 284, 285, 286, 287, 288, 289, 290, 291, 292, 293, 294, 295, 296, 297, 298, 299, 300, 301, 302, 303, 304, 305, 306, 307, 308, 309, 310, 311, 312, 313, 314, 315, 316, 317, 318, 319, 320, 321, 322, 323, 324, 325, 326, 327, 328, 329, 330, 331, 332, 333, 334, 335, 336, 337, 338, 339, 340, 341, 342, 343, 344, 345, 346, 347, 348, 349, 350, 351, 352, 353, 354, 355, 356, 357, 358, 359, 360, 361, 362, 363, 364, 365, 366, 367, 368, 369, 370, 371, 372, 373, 374, 375, 376, 377, 378, 379, 380, 381, 382, 383, 384, 385, 386, 387, 388, 389, 390, 391, 392, 393, 394, 395, 396, 397, 398, 399, 400, 401, 402, 403, 404, 405, 406, 407, 408, 409, 410, 411, 412, 413, 414, 415, 416, 417, 418, 419, 420, 421, 422, 423, 424, 425, 426, 427, 428, 429, 430, 431, 432, 433, 434, 435, 436, 437, 438, 439, 440, 441, 442, 443, 444, 445, 446, 447, 448, 449, 450, 451, 452, 453, 454, 455, 456, 457, 458, 459, 460, 461, 462, 463, 464, 465, 466, 467, 468, 469, 470, 471, 472, 473, 474, 475, 476, 477, 478, 479, 480, 481, 482, 483, 484, 485, 486, 487, 488, 489, 490, 491, 492, 493, 494, 495, 496, 497, 498, 499, 500, 501, 502, 503, 504, 505, 506, 507, 508, 509, 510, 511, 512, 513, 514, 515, 516, 517, 518, 519, 520, 521, 522, 523, 524, 525, 526, 527, 528, 529, 530, 531, 532, 533, 534, 535, 536, 537, 538, 539, 540, 541, 542, 543, 544, 545, 546, 547, 548, 549, 550, 551, 552, 553, 554, 555, 556, 557, 558, 559, 560, 561, 562, 563, 564, 565, 566, 567, 568, 569, 570, 571, 572, 573, 574, 575, 576, 577, 578, 579, 580, 581, 582, 583, 584, 585, 586, 587, 588, 589, 590, 591, 592, 593, 594, 595, 596, 597, 598, 599, 600, 601, 602, 603, 604, 605, 606, 607, 608, 609, 610, 611, 612, 613, 614, 615, 616, 617, 618, 619, 620, 621, 622, 623, 624, 625, 626, 627, 628, 629, 630, 631, 632, 633, 634, 635, 636, 637, 638, 639, 640, 641, 642, 643, 644, 645, 646, 647, 648, 649, 650, 651, 652, 653, 654, 655, 656, 657, 658, 659, 660, 661, 662, 663, 664, 665, 666, 667, 668, 669, 670, 671, 672, 673, 674, 675, 676, 677, 678, 679, 680, 681, 682, 683, 684, 685, 686, 687, 688, 689, 690, 691, 692, 693, 694, 695, 696, 697, 698, 699, 700, 701, 702, 703, 704, 705, 706, 707, 708, 709, 710, 711, 712, 713, 714, 715, 716, 717, 718, 719, 720, 721, 722, 723, 724, 725, 726, 727, 728, 729, 730, 731, 732, 733, 734, 735, 736, 737, 738, 739, 740, 741, 742, 743, 744, 745, 746, 747, 748, 749, 750, 751, 752, 753, 754, 755, 756, 757, 758, 759, 760, 761, 762, 763, 764, 765, 766, 767, 768, 769, 770, 771, 772, 773, 774, 775, 776, 777, 778, 779, 780, 781, 782, 783, 784, 785, 786, 787, 788, 789, 790, 791, 792, 793, 794, 795, 796, 797, 798, 799, 800, 801, 802, 803, 804, 805, 806, 807, 808, 809, 810, 811, 812, 813, 814, 815, 816, 817, 818, 819, 820, 821, 822, 823, 824, 825, 826, 827, 828, 829, 830, 831, 832, 833, 834, 835, 836, 837, 838, 839, 840, 841, 842, 843, 844, 845, 846, 847, 848, 849, 850, 851, 852, 853, 854, 855, 856, 857, 858, 859, 860, 861, 862, 863, 864, 865, 866, 867, 868, 869, 870, 871, 872, 873, 874, 875, 876, 877, 878, 879, 880, 881, 882, 883, 884, 885, 886, 887, 888, 889, 890, 891, 892, 893, 894, 895, 896, 897, 898, 899, 900, 901, 902, 903, 904, 905, 906, 907, 908, 909, 910, 911, 912, 913, 914, 915, 916, 917, 918, 919, 920, 921, 922, 923, 924, 925, 926, 927, 928, 929, 930, 931, 932, 933, 934, 935, 936, 937, 938, 939, 940, 941, 942, 943, 944, 945, 946, 947, 948, 949, 950, 951, 952, 953, 954, 955, 956, 957, 958, 959, 960, 961, 962, 963, 964, 965, 966, 967, 968, 969, 970, 971, 972, 973, 974, 975, 976, 977, 978, 979, 980, 981, 982, 983, 984, 985, 986, 987, 988, 989, 990, 991, 992, 993, 994, 995, 996, 997, 998, 999, 1000



ERIC
Full Text Provided by ERIC

AMM 1/24

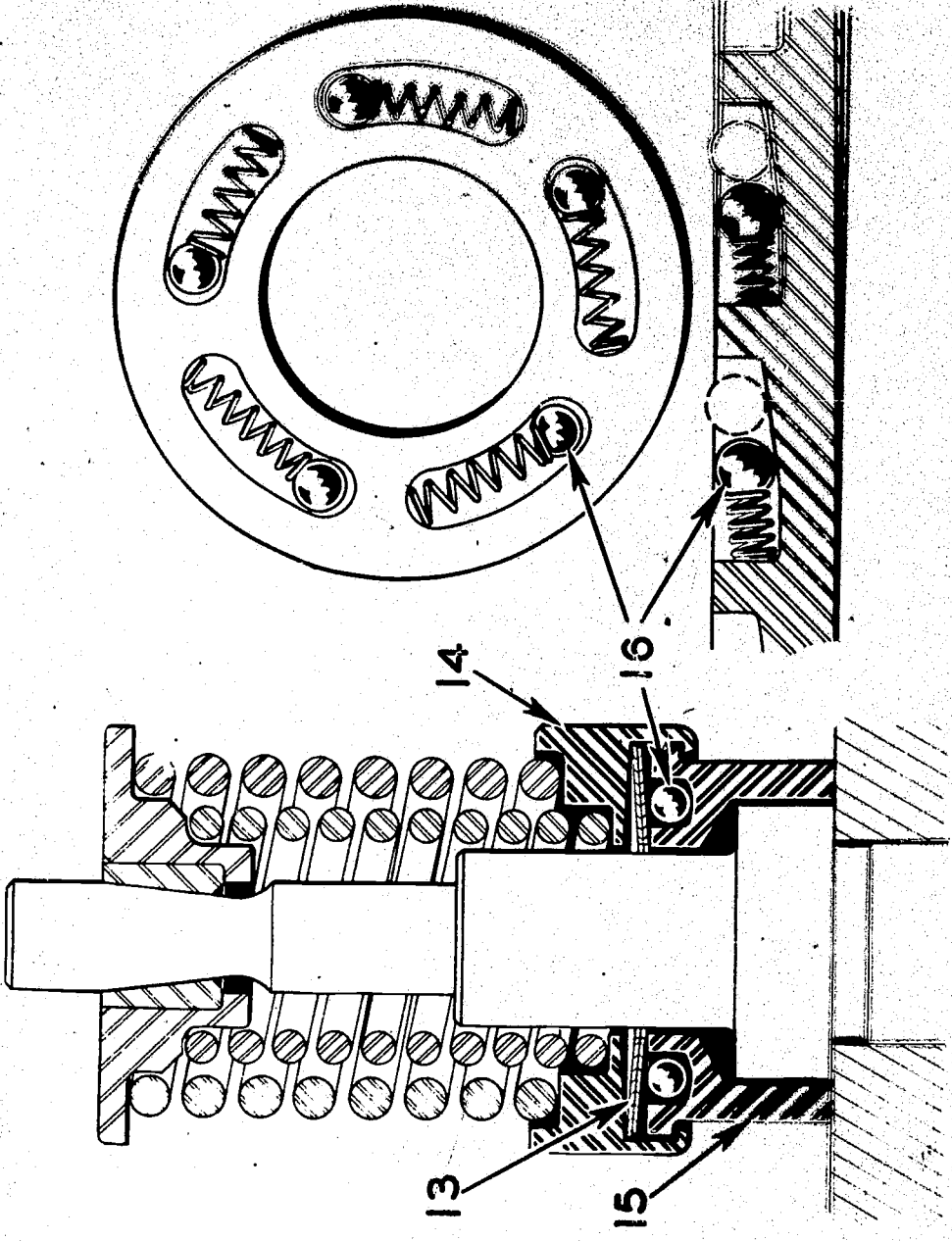

VALVE ROTATION

13-Valve stem, 14-Spring washer, 15-Valve seat, 16-Valve body

INSTRUCTOR'S GUIDE

Title of Unit: I -- Maintaining The Air System --
Caterpillar Diesel Engine
II -- Understanding Rear End Suspension

AM 1-21
8/9/66

OBJECTIVES:

1. To introduce one of the four flows (air) of the caterpillar engine to the student.
2. To point out the differences of the CAT engine's air system in relation to GM and Cummins.
3. To give the student a brief description of rear end suspension structure.

LEARNING AIDS suggested:

Vu-Graph Cells:

- AM 1-21 (1) Turbocharged Engine Air System
- AM 1-21 (2) Pressure Ratio Regulator, Valve Closed
- AM 1-21 (3) Pressure Ratio Regulator, Valve Open
- AM 1-21 (4) Conventional Cat Engine
- AM 1-21 (5) Series A and B Cat Engine
- AM 1-21 (6) Valve Adjustment
- AM 1-21 (7) Valve Rotator

Models:

Any models of the CAT air system components you can bring to class is most helpful. Possibly the nearest CAT distributor can supply cutaways etc.

QUESTIONS FOR DISCUSSION AND GROUP PARTICIPATION:

1. Are CAT engines two cycle or four cycle ?
2. How many intake and exhaust valves does a D340T (824 and 988 machines) six cylinder CAT engine have ?
3. How is the speed of the turbocharger controlled? Is it automatic? Explain
4. What is the purpose of having a turbocharger ?
5. What is the purpose of having an aftercooler on turbocharged engines ?

Instructor's Guide for AM 1-21

page two

Questions for Discussion and Group Participation cont'd

- 6. How does the built-in starting aid work on a Cat engine ?**
- 7. How does the aspirator work on the FARR air cleaner?**
- 8. What is the venturi principle? Give some examples of this principle.**
- 9. What effect does the priority valve have on the turbocharger?**
- 10. What is a valve rotator ?**
- 11. How can you determine if the valve rotators are operating ?**
- 12. How many valve rotators are there on a six cylinder CAT engine?**