

R E P O R T R E S U M E S

ED 021 086

VT 005 669

AUTOMOTIVE DIESEL MAINTENANCE 1. UNIT XV, I--MAINTAINING THE COOLING SYSTEM, CUMMINS DIESEL ENGINE, I--UNIT INSTALLATION--TRANSMISSION.

HUMAN ENGINEERING INSTITUTE, CLEVELAND, OHIO

REPORT NUMBER AM-1-15

PUB DATE 26 APR 66

EDRS PRICE MF-\$0.25 HC-\$1.72 41P.

DESCRIPTORS- \*STUDY GUIDES, \*TEACHING GUIDES, \*TRADE AND INDUSTRIAL EDUCATION, \*AUTO MECHANICS (OCCUPATION), \*DIESEL ENGINES, ADULT VOCATIONAL EDUCATION, TRANSPARENCIES, PROGRAMED MATERIALS, INDIVIDUAL INSTRUCTION, INSTRUCTIONAL FILMS, PROGRAMED INSTRUCTION, MOTOR VEHICLES, EQUIPMENT MAINTENANCE,

THIS MODULE OF A 30-MODULE COURSE IS DESIGNED TO DEVELOP AN UNDERSTANDING OF THE FUNCTION AND MAINTENANCE OF THE DIESEL ENGINE COOLING SYSTEM AND THE PROCEDURES FOR TRANSMISSION INSTALLATION. TOPICS ARE (1) IMPORTANCE OF THE COOLING SYSTEM, (2) COOLING SYSTEM COMPONENTS, (3) EVALUATING COOLING SYSTEM FAILURES, (4) CARING FOR THE COOLING SYSTEM, (5) PREPARATION FOR INSTALLATION (TRANSMISSION), AND (6) INSTALLING TRANSMISSION. THE MODULE CONSISTS OF A SELF-INSTRUCTIONAL BRANCH PROGRAMED TRAINING FILM "PRINCIPLES OF DIESEL ENGINE COOLING SYSTEMS" AND OTHER MATERIALS. SEE VT 005 655 FOR FURTHER INFORMATION. MODULES IN THIS SERIES ARE AVAILABLE AS VT 005 655 - VT 005 684. MODULES FOR "AUTOMOTIVE DIESEL MAINTENANCE 2" ARE AVAILABLE AS VT 005 685 - VT 005 709. THE 2-YEAR PROGRAM OUTLINE FOR "AUTOMOTIVE DIESEL MAINTENANCE 1 AND 2" IS AVAILABLE AS VT 006 006. THE TEXT MATERIAL, TRANSPARENCIES, PROGRAMED TRAINING FILM, AND THE ELECTRONIC TUTOR MAY BE RENTED (FOR \$1.75 PER WEEK) OR PURCHASED FROM THE HUMAN ENGINEERING INSTITUTE, HEADQUARTERS AND DEVELOPMENT CENTER, 2341 CARNEGIE AVENUE, CLEVELAND, OHIO 44115. (HC)

STUDY AND READING MATERIALS

# AUTOMOTIVE DIESEL MAINTENANCE

# 1

I -- MAINTAINING THE COOLING SYSTEM,  
CUMMINS DIESEL ENGINE

II -- UNIT INSTALLATION - TRANSMISSION, /UNIT XV

## TABLE OF CONTENTS

### PART I

- SECTION A IMPORTANCE OF THE COOLING SYSTEM
- SECTION B COOLING SYSTEM COMPONENTS
- SECTION C EVALUATING COOLING SYSTEM FAILURES
- SECTION D CARING FOR THE COOLING SYSTEM

### PART II

- SECTION A PREPARATION FOR INSTALLATION
- SECTION B INSTALLING TRANSMISSION

AM 1-15  
4/26/66

U.S. DEPARTMENT OF HEALTH, EDUCATION & WELFARE  
OFFICE OF EDUCATION

THIS DOCUMENT HAS BEEN REPRODUCED EXACTLY AS RECEIVED FROM THE PERSON OR ORGANIZATION ORIGINATING IT. POINTS OF VIEW OR OPINIONS STATED DO NOT NECESSARILY REPRESENT OFFICIAL OFFICE OF EDUCATION POSITION OR POLICY.

HUMAN ENGINEERING INSTITUTE

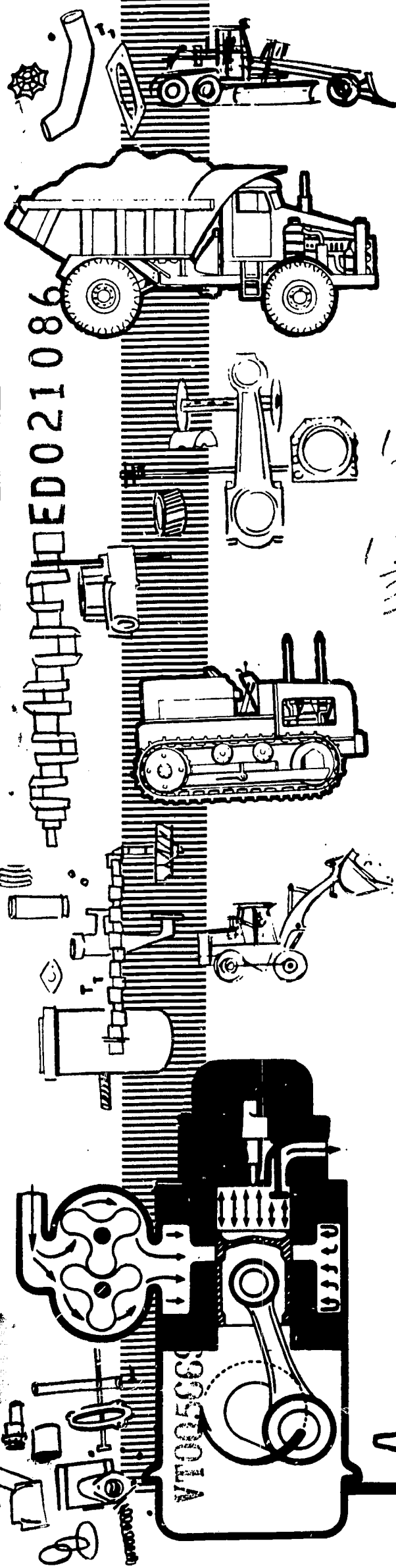

ED021086

VT005089

This unit is in two parts. The first half covers the operation of the Cummins Diesel cooling system and its related components. The second half covers a brief discussion of installing number 5960 or 6061 Allison Transmission from 14 or 15 FFD Euclid tractors, or M-45 and LYSW Mack Tractors.

## PART I -- MAINTAINING THE COOLING SYSTEM CUMMINS DIESEL ENGINES

### SECTION A -- IMPORTANCE OF THE COOLING SYSTEM

The great increases in diesel engine speeds and horsepower during recent years make it increasingly important for maintenance mechanics to understand and appreciate the vital role of the cooling system in maintaining top engine performance. Accompanying these increases in horsepower and rpm's, are corresponding increases in the amount of excess heat which the cooling system must remove from the engine. This excess heat is much greater than is realized. The cooling system of a large vehicle for instance, removes enough heat at cruising speed to keep several large homes warm in below freezing temperature. To handle this amount of a heat load, the cooling system must circulate as much as 20,000 gallons of coolant through the engine each working shift. If the coolant fails to remove its quota of heat, excessive temperatures (over 225 F), will overheat the oil, break it down and cause harmful chemical changes in the oil body. This in turn produces sludge and varnish, causing seals and gaskets to become hard and brittle, and resulting in leaks and eventually cracked heads due to heat stress.

On the other hand, an improperly controlled cooling system which overcools the engine is equally harmful. When engine operating temperatures are too low, (below 165 F), lubricating oil is diluted by unburned fuel and by sludge which results from condensation of water in the cylinders and crankcase. The unburned fuel is a result of the cool cylinder walls retarding the heating of air during compression, which causes ignition delay. Also there will be excessive carbon build-up because of incomplete combustion.

The function of the cooling system is to control the temperature of engine metals within safe limits. To do this properly, the cooling system must perform four major functions: absorption, circulation, radiation, and control, see Figure 1.

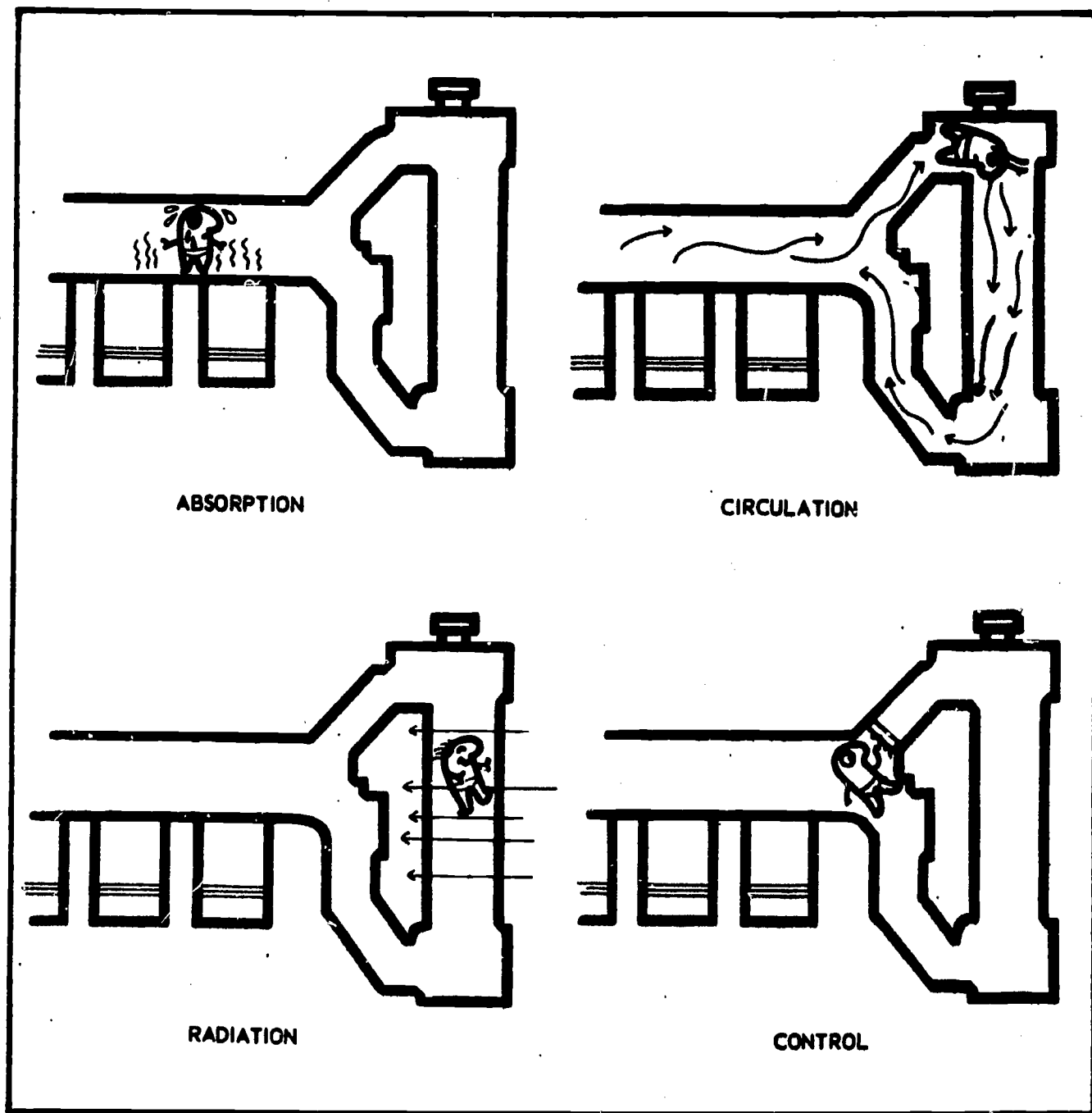

Fig. 1 Basic functions of the cooling system.



**ABSORPTION** - Heat produced by combustion in a diesel engine is transferred from the combustion areas in three ways. Approximately one-third is converted into useful horsepower, while another third is removed with the exhaust gases. The remaining third is absorbed and carried away by the lubricating oil, the air stream, and most important by the coolant. The hottest part of a diesel engine is the area surrounding the cylinders. Heat is concentrated particularly in the metal making up the combustion chambers. In fact, when an engine is operating under full load, the cooling system gets rid of enough heat every hour to melt the entire engine if it were allowed to accumulate.

**CIRCULATION** - After the coolant absorbs heat from the engine parts, it carries the heat to the radiator or heat exchanger where it is carried off. To do this, a number of component parts are required. The most important of these parts is the water pump, which forces the coolant through the water header, the water jacket, the water manifold, the thermostat control and by-pass connection, the radiator, the oil cooler, and back to the pump. The necessary high volume of coolant flow is made possible by a recirculation by-pass which permits flow in the engine block and head areas at all times, regardless of whether the thermostat is opened or closed. Naturally, if the passages in the head and block areas are not kept open and clear, proper circulation is not possible; see Figure 2.

**RADIATION** - After the coolant has circulated through the engine and has absorbed engine heat, it passes from the engine and enters an outlet hose connection, usually at the top and front of the engine block, which directs it to the radiator or heat exchanger. The hot coolant enters the radiator through the top tank, then passes through a series of small water tubes surrounded by fins and air passages. The air stream which is forced between these tubes and fins by the fan, removes the heat. The coolant, which has now been cooled, leaves the radiator and flows through a lower hose connection to the water pump, and the cycle is repeated. **NOTE:** It is extremely important that the fan and shroud be in good condition, and the fan belts be adjusted to the proper tension.

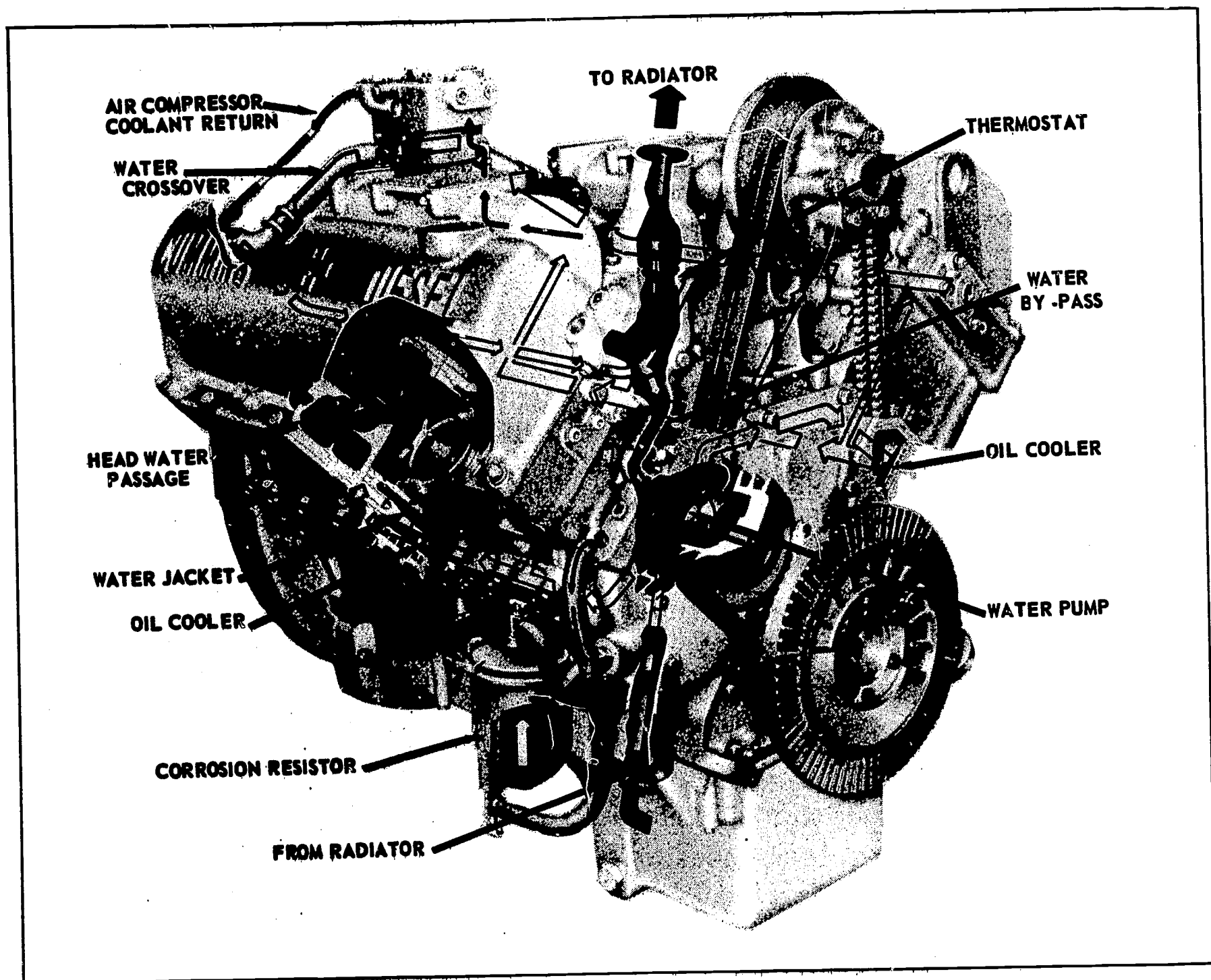

Fig. 2 Coolant flow through a Cummins V8 engine.

**CONTROL** - Another function of the cooling system is to maintain correct engine operating temperature. A thermostat and by-pass connection prevents circulation of the coolant through the radiator or heat exchanger until it reaches normal operating temperature. Naturally, the quicker an engine reaches operating temperature the better. A cold running engine allows harmful condensation of combustion gases. This results in sludge formation in the lubricating oil and increased wear and corrosion of engine parts. To insure quick warm up, the thermostat and by-pass connection "holds" the circulating coolant in the engine block and heads until operating temperature is reached (165 to 195F). Once the engine reaches operating temperature the thermostat opens.

### SECTION B -- COOLING SYSTEM COMPONENTS

To better understand the parts of a cooling system, trace the flow of coolant through the engine in Figure 2. Notice that the cylinder liner is of the wet type, in which coolant touches the upper half. Approximately half way down, a rubber "O" ring encircles the liner, preventing coolant from entering the crankcase.

After the heat has been removed from the coolant in the radiator, it passes from the radiator to the water header (see Figure 2), a large drilling that extends the full length of the upper portion of the engine block.

**WATER HEADER** - The water header distributes the coolant to the water jackets surrounding the cylinder liners in the block and covering the combustion chambers in the cylinder head. In the block, the water jackets completely surround the liners and draw heat away from combustion chambers and valve seats. Water jackets are a very important component of the cooling system for they permit the coolant to reach the hottest parts of the engine. If the water jackets are not free of all obstructions, including dirt, scale, and sludge, coolant circulation may become so limited that heat will not be carried away fast enough to prevent the development of damaging "hot spots" in the engine.



**WATER MANIFOLD** - After the coolant has passed through the water jackets and absorbed vast quantities of heat, it goes to the water manifold, then to the thermostat housing and by-pass connection.

The water manifold, see Figure 3, is made up of sections joined together by couplings. And, like the water header, it runs the full length of the engine. However, it is installed on the outside of the engine instead of being built into it.

**THERMOSTATS** are constructed to open when the temperature reaches a specified level and to close when it drops below that level. They are identified by their heat range. Standard thermostats start to open at 160 F, and are fully open at 175 F. Higher range thermostats maintain a temperature 10 to 20 degrees higher. In extreme cold areas, such as northern Minnesota, even higher temperatures are maintained, to improve cab heater performance.

Keep in mind that the thermostat control and by-pass connection performs a dual function. When a cold engine is first started, the thermostat helps the engine reach operating temperature quickly. But, when an engine is operating under only partial load, the thermostat by-pass arrangement prevents the cooling system from overcooling the engine to a temperature below that which is considered satisfactory for efficient operation. When the engine operation temperature is below normal, the thermostat closes, permitting the coolant to circulate only through the engine. The by-pass, as its name implies, directs the coolant back to the water header when the thermostat is closed, see Figure 4.

**RADIATOR** - The radiator or heat exchanger, as mentioned earlier, carries off the heat that the coolant has absorbed as it passes through the engine. The radiator consists of an upper tank, a core and a lower tank. The upper tank has an inlet connection to receive engine coolant from the thermostat housing. The opening at the top of the upper tank has a neck to which the filler cap is attached. An overflow line leads from a point



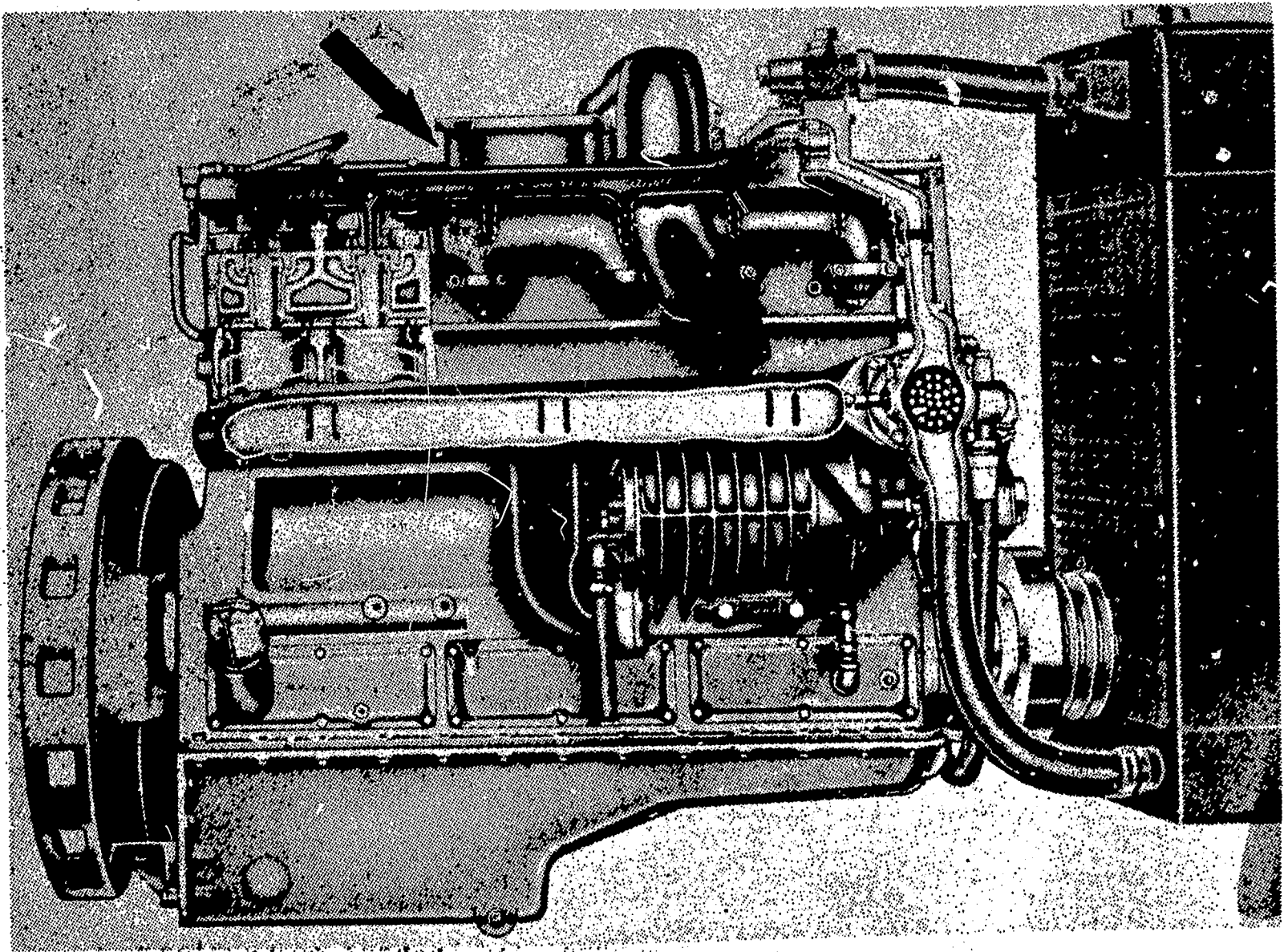
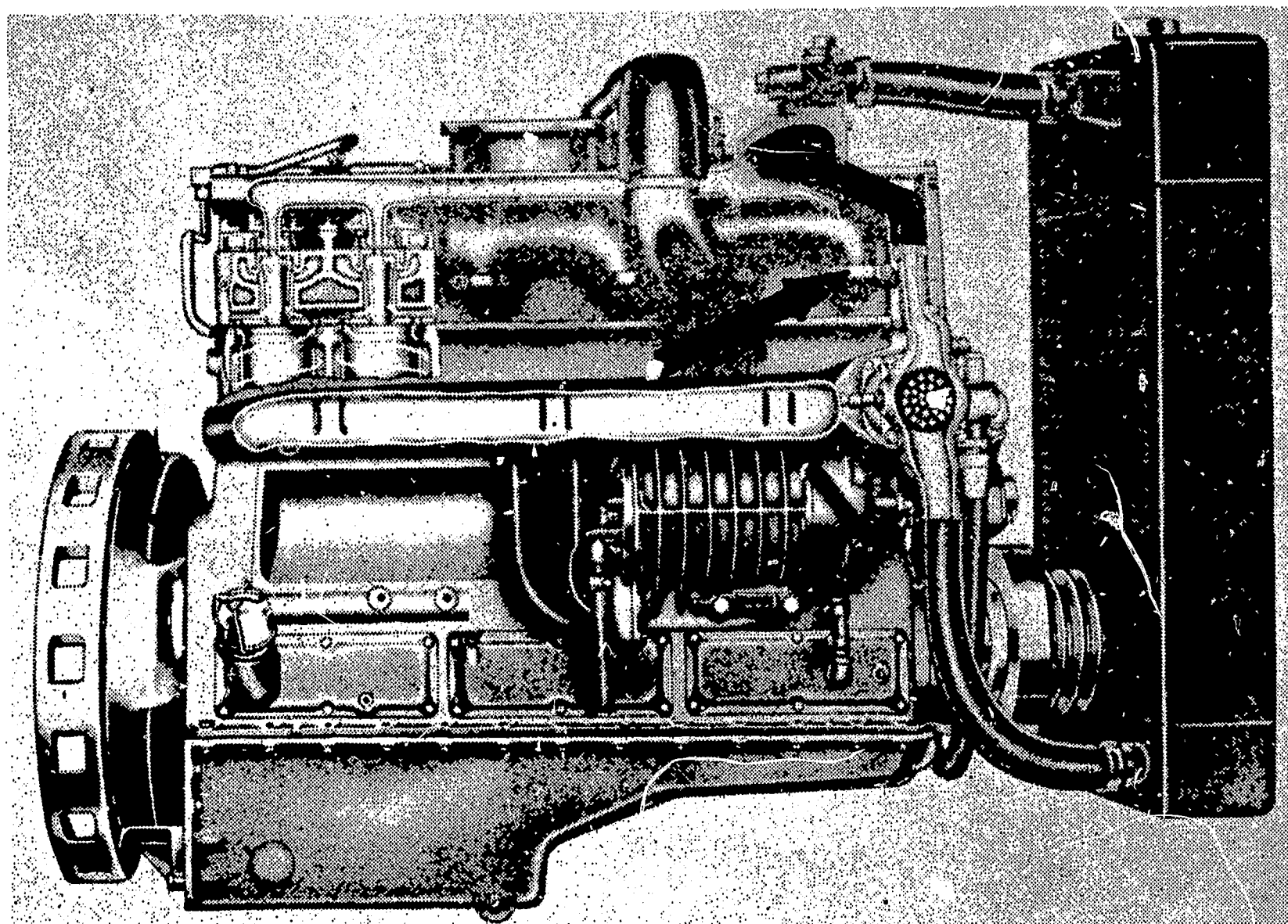

Fig. 3 Water manifold.



**Fig. 4 Thermostat control and by-pass connections.**



mid-way in the neck. This overflow line provides for the escape of excess coolant if the radiator is overfilled, or if heat expands the coolant and releases the pressure relief valve in the filler cap; see Figure 5.

**WITHNELL TUBE RADIATOR** - The Withnell replaceable tube type radiator, which grew popular on the Mesabi Range and now is almost exclusively used in the Taconite Mining Industry, can be subjected to the heavy pounding and vibration which is common to off-highway equipment. The principle of operation of the Withnell is the same as the radiator in Figure 5, except that the tubes located between the upper and lower tanks of the radiator are seated in rubber grommets and are replaceable. The conventional type radiator, Figure 5, has all soldered joints and is in one piece. It is easy to see where money, and especially time, could be saved should a truck radiator be damaged. Figure 6 shows replaceable tubes being installed in the old radiator frame. Notice the rubber grommets which the tubes slide into.

**PRESSURIZED SYSTEMS** - Most cooling systems in use today are "pressurized". Pressurizing the cooling system raises the temperature at which the coolant will boil and results in more effective cooling. For example, 4 psi pressure raises the boiling point of water from 212 F to about 225 F. Increasing the pressure even more raises the boiling point proportionally. Most pressure caps on off-highway equipment radiators are rated at 7 psi.

To control cooling system pressure, the cap contains both a safety and pressure release valve and a vacuum valve. When the pressure in the cooling system is preset, the valve opens. This allows the coolant, under pressure, to escape through the overflow line until pressure is reduced. The vacuum valve opens when the pressure in the cooling system drops below atmospheric pressure. This occurs during cooling after engine overheating. The action of this valve prevents the possibility of collapsed hoses.

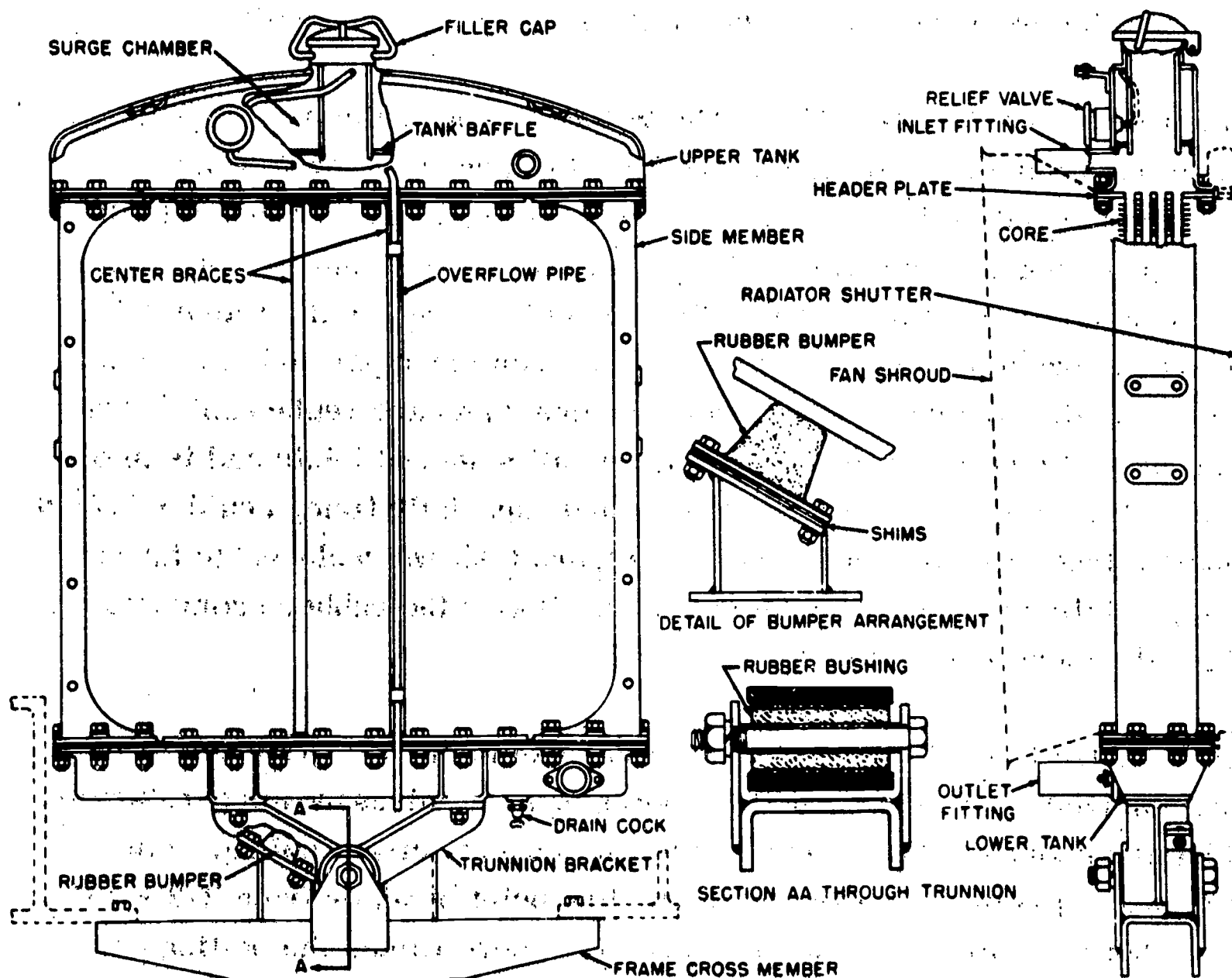

Fig. 5. Typical radiator for off-highway equipment.



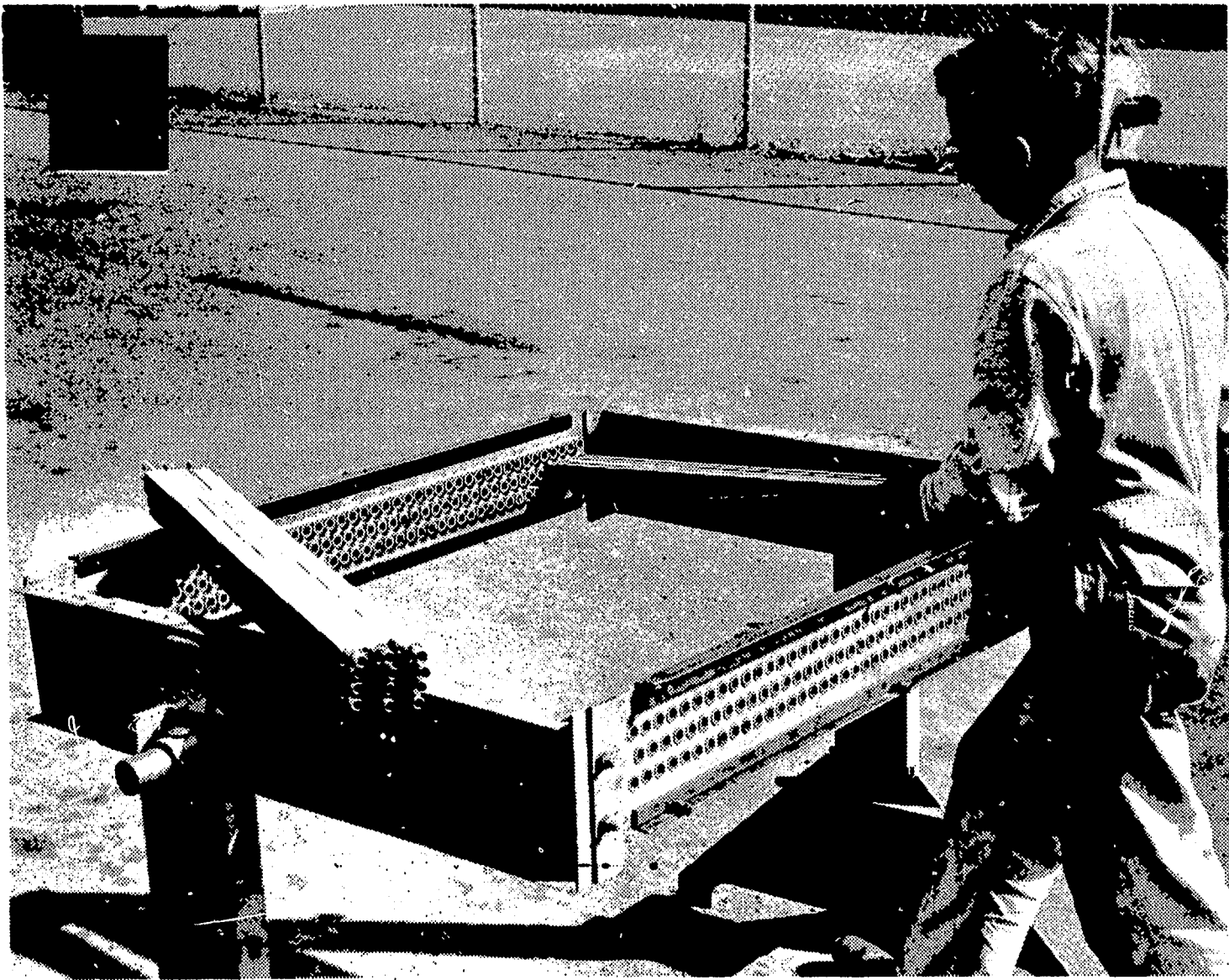

Fig. 6 Installing new tubes in Withnell radiator.

**OIL COOLER** - After leaving the radiator or heat exchanger, the coolant travels to the oil cooler and absorbs heat from the lubricating oil passing through it. Without an oil cooler the only way oil can be cooled is by radiation from the oil pan. Thus with an oil cooler installed it is possible to equip engines with smaller oil pans.

From the oil cooler, the coolant travels to the water pump and is again circulated through the cooling system.

**WATER PUMP** - All Cummins water pumps are of the "volute" centrifugal curved impeller type pump. Figure 7 is a simplified diagram showing how this type of pump operates.

As you will recall from AM 1-11D, in the discussion of centrifugal pumps, the "volute" refers to the contour of the pump's casing. The casing is made to form a progressively expanding passageway into which the impeller

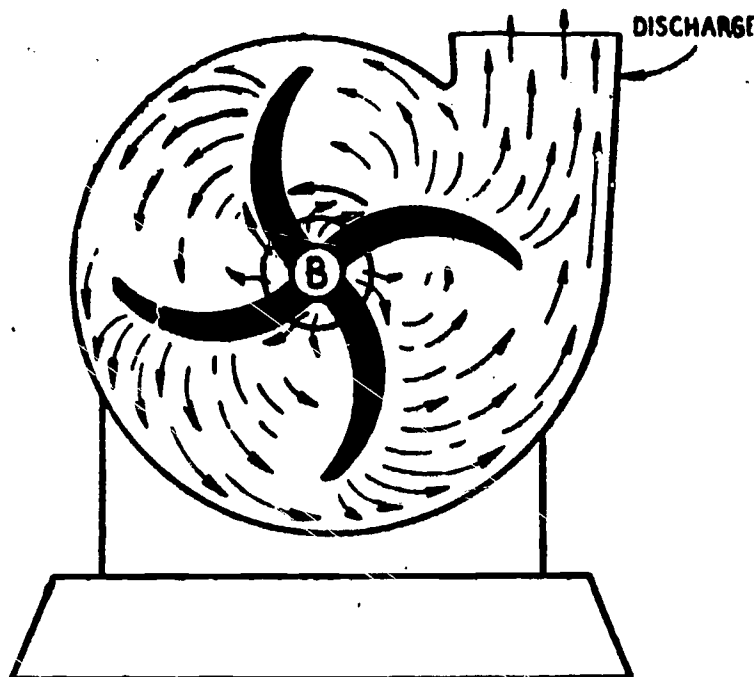

Fig. 7 Centrifugal pump.

discharges the water. The volute actually collects the water from the twirling impeller and directs it to the opening. If this is not clear, re-view the film AM 1-11D; it will be worth while.

**WATER FILTER AND CONDITIONER** - The water conditioner, sometimes called a "corrosion resistor" is a unit through which coolant is directed for treatment. Figure 8 shows the corrosion resistor used on the Cummins Engines.

As coolant enters the corrosion resistor from the bottom, it passes through a removable cloth filter and over a magnesium corrosion plate. As it continues through the resistor it picks up certain chemicals contained in the element, then passes through the outlet line to the cooling system. The cloth filter removes dirt and foreign particles.

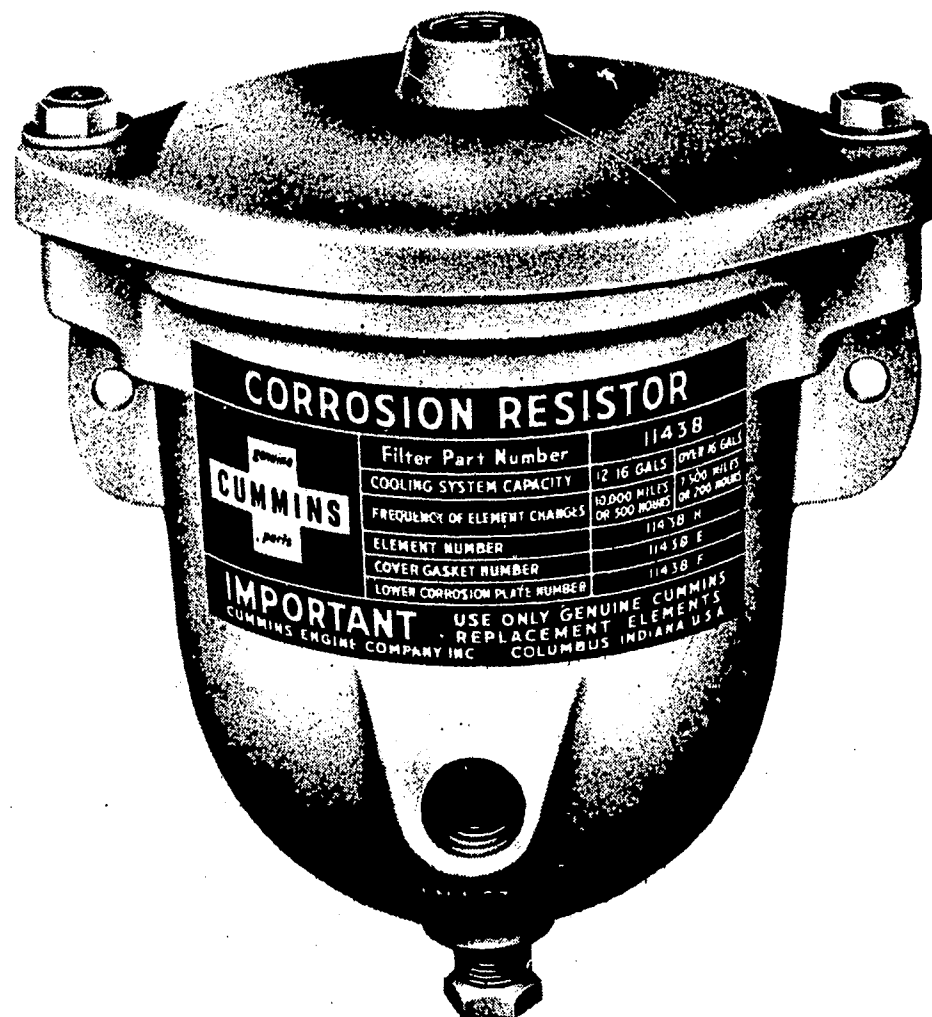

Fig. 8 Cummins corrosion resistor.



Water is "softened" by the addition of chemical inhibitors, which prevent a build-up of lime deposits in the cooling system passages. Lime deposits from "hard" water would soon clog the radiator and other parts of the cooling system.

Other chemicals, called "buffering agents," are added to the water to control its pH or acid concentration. If not checked, acids can be extremely corrosive to the walls of the cooling system.

The corrosion resistor also provides a combination of chemical inhibitors, containing chromates, which check rust accompanying corrosion in the cooling system.

Electrochemical action which would result in pitting of the metal of the cooling system, particularly the outer walls of the cylinder liners, is prevented to a great extent by the action of a replaceable magnesium plate in the corrosion resistor. Corrosion which would ordinarily attack other parts of the cooling system concentrates its action on the magnesium plate, which is more readily affected than are the cooling system metals. Thus the cylinder liners and block are protected from corrosive action.

### SECTION C -- EVALUATING COOLING SYSTEM FAILURES

**HIGH EXHAUST BACK PRESSURE** - When evaluating cooling system failures, it is important to remember that engine overheating can result from causes other than failure of the cooling system. For example, high exhaust back pressure causes poor engine breathing, which results in fuel burning within the exhaust manifold. This burning fuel, passing through the area of the exhaust valve ports, adds a considerable amount of heat to the engine coolant. Then, as the burning fuel passes through the exhaust manifold, the manifold becomes overheated. Heat from the exhaust manifold is transferred externally to the engine coolant in the adjacent water manifold.



**FUEL SYSTEM** - Engine overheating also can be caused by an incorrectly calibrated fuel system. Engine heat is increased so much by overfueling that the cooling system may be unable to carry away excess heat fast enough.

**LOW OIL LEVEL** - Improper lubricating oil level is also an important factor. If the level is too low for adequate lubrication, overheating of bearings will occur. Such overheating can take place very quickly, particularly when the vehicle is operating on an incline. If the operator fails to notice immediately any sudden rise in coolant temperature, the engine may fail from damaged bearings.

**ENGINE CONDITION** - The mechanical condition of the engine can affect proper cooling. Valve timing and the fit of the pistons and piston rings, as well as bearing clearance, can increase the heat output of an engine until the cooling system cannot do an adequate job.

**COOLING SYSTEM** - Engine damage from overheating can also stem from cooling system failure. Perhaps the most frequent cause for engine overheating is insufficient coolant. Loss of coolant may be due to a leaking radiator or radiator hoses. Coolant also may boil out of the radiator or evaporate if the radiator tank is too small.

A leaking radiator usually is easily detected. However, damaged water hoses are not always obvious, because they usually start to collapse or break apart internally. Naturally, as parts of the hose break away internally, they may clog the water passages. This is one of the principal causes for inadequate engine cooling.

Water passages also may become clogged by dirty coolant or from scale formed within the engine. Actually, not all cases of overheating can be determined by observing the water temperature gauge. A cylinder head, for instance, may overheat and crack without any warning from the

temperature gauge. This could occur since the gauge shows only the temperature for that part of the system in which it is installed. If the system is clogged at a point beyond where the gauge is installed, overheating may occur without being indicated on the gauge.

Other causes for cooling system failures include a worn water pump, such as one having seriously corroded pump vanes, faulty thermostat, loose water pump belts, loose fan belts, and plugged radiator core tubes.

Air entrainment (presence of air in coolant) and coolant foaming (presence of oil in the coolant) are both very detrimental to the engine.

Air is entrained, or picked up, as the coolant rushes into the confining upper tank of the radiator, much the same as would occur when squirting a garden hose into a bucket of water.

The air thus driven into the coolant is carried down through the tubes into the water pump, where it forms an "air pocket", resulting in an "air locked" pump. Entrainment is more pronounced when the coolant level of the upper tank is low and coolant splashes in from above that level. If the coolant level is so low that the radiator tubes are uncovered, air may be drawn directly into them. The flow of coolant then will be greatly reduced and may even stop if the pump becomes completely "air locked."

**SURGE TANK** - The most effective way to prevent air entrainment in the cooling system is to provide a surge tank, or auxiliary coolant tank, see Figure 9. In a system where a surge tank is used at a level above the upper tank of the radiator, the coolant from the auxiliary tank flows into the engine cooling system through an inlet connection at the bottom of the radiator. This maintains the correct coolant level in the upper tank.

A bleeder line is inserted into the top of the upper tank so that any air that is present may escape to the auxiliary tank. This arrangement eliminates the causes of air entrainment common in inadequately sized radiators.

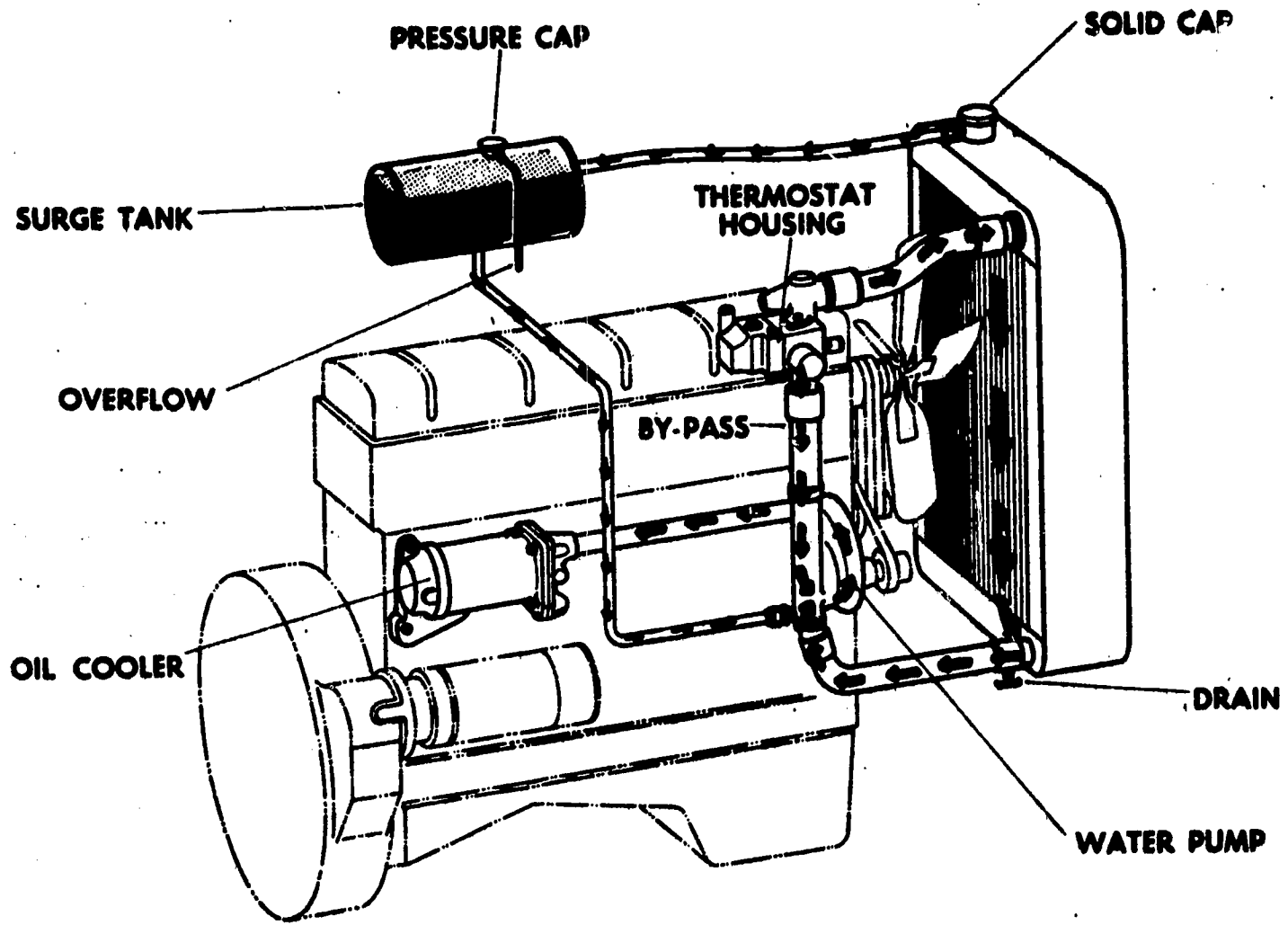

Fig. 9 Cooling system with auxiliary tank installed.

**COOLANT FOAMING** - This condition of the coolant is caused by two situations. Oil can leak into the coolant through worn gaskets, leaky seals, etc. Or using a cheap grade of ethylene glycol without a foaming additive will quickly contaminate the coolant. As mentioned above, coolant foaming is very detrimental to engine components such as heads, valves, liners, etc., by creating hot spots and inducing corrosion.

### SECTION D -- CARING FOR THE COOLING SYSTEM

**ENGINE DEPOSITS** - A continual process of physical and chemical changes in the cooling system results in accumulations that insulate engine heat from the coolant and restrict coolant flow. A light accumulation may reduce the heat transfer efficiency of the system enough to cause overheating in hot weather, at high altitudes or under heavy load. Another aspect of cooling system deposits is the tendency to build up faster in the hot areas, especially around the valve ports. This causes a local hot spot condition that is a hidden, but common, cause of overflow loss and burned valves. Figure 10 shows the build-up of deposits around the hot areas of the valves.

These deposits act as insulators and, if they are allowed to continue building up, engine efficiency will be destroyed.

These deposits must be removed with a cleaner at regular intervals to maintain new vehicle efficiency. If the system is neglected until heavy deposits have formed, a major operation involving dismantling of the engine becomes necessary.

The use of a rust inhibitor in

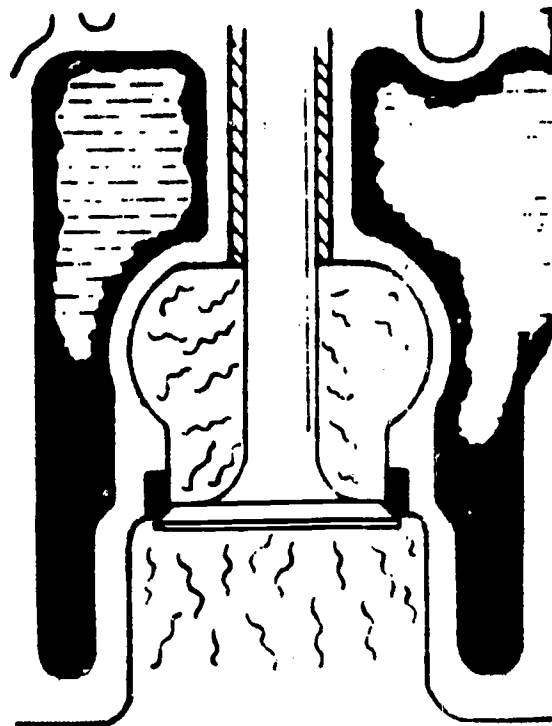

Fig. 10 Coolant deposits around hot spots in the engine.



summer, and an inhibited anti-freeze in winter, reduces the rate of accumulation. However, rust inhibitors do not protect a system indefinitely; they become contaminated with use, and lose their effectiveness. Twice a year (each spring and fall) is a satisfactory cleaning schedule for most operations.

**RADIATOR DEPOSITS** - The most common formations are rust, silicate or carbonate scale, and sludge. Rusting of the metal surfaces results from excessive aeration, combustion leakage, or contamination of the inhibitor. Scale is formed when minerals in the water are deposited on the cooling surfaces. For this reason, the use of water having a heavy mineral content should be avoided whenever possible. A very troublesome, but less common, scale is that formed by a high calcium sulphate content. This gypsum scale resists strong tank cleaners. Sludge is formed when grease or oil enters the system and is usually present to some extent in all systems.

**CLEANING AGENTS** - There are two general classes of cooling system cleaners: Alkaline cleaners, most effective for removing sludge and silicate scale, and inhibited acid cleaners, most effective for removing rust and carbonate scale. It is desirable to use an alkaline cleaner first, regardless of the type of scale. This insures the removal of sludge that might otherwise make a rust or carbonate scale from an acid cleaner. If an alkaline cleaner fails to remove all scale, it can be followed by an acid cleaner with full effect. Although rust inhibited acid cleaners do not attack sound metal while cleaning, prolonged contact may result in corrosive action. For this reason, it is good practice to follow an acid cleaner with a neutralizer to remove all traces of residual acid left in the system.

It is necessary to run the engine during the cleaning operation because cleaning solutions are more effective when hot and in motion. Very little heat is developed while running without load; partial covering of the radiator may be necessary to maintain a desirable solution temperature (180 F to 200 F).

**CAUTION:** If there is a doubt as to what to use for cleaning agents, check the maintenance manual or the nearest engine supplier.

**RADIATOR FLUSHING** - Most manufacturers of cooling system cleaners recommend a flushing operation after the cleaner has been drained, to insure complete removal of loosened deposits. Reverse flow flushing, or back flushing, is the most effective method. This requires the use of a flushing gun having air and water fittings.

**NOTE:** If flushing is performed immediately after draining the cleaning solution, it is advisable to flush the radiator first, allowing the engine to cool as much as possible.

**REVERSE FLUSHING** - Disconnect the hoses at the engine, tighten the radiator cap and clamp the flush gun in the lower hose. Use a hose clamp to secure the flushing gun in place. The hoses supplied on the vehicle can be used for this operation, but it is usually more convenient to use longer lengths, as shown-see Figure 11. Fill the radiator with water and apply air pressure carefully and intermittently for two or three seconds at a time to avoid radiator damage. Repeat until the water turns clear. Be sure to clean and inspect the radiator cap; see Figure 11.

**FLUSHING THE ENGINE WATER JACKET** - Remove the thermostat, block off the by-pass by installing a plate between the by-pass fitting and the pump hose, clamp the flushing gun in the upper hose and fill the jacket with water. Use approximately 80 pounds of air pressure to blow the water from the block. Repeat until the water runs clear. Don't forget to remove the plate after flushing.

**NOTE:** When flushing an engine containing a large amount of loose rust or scale, it is advisable to remove the water

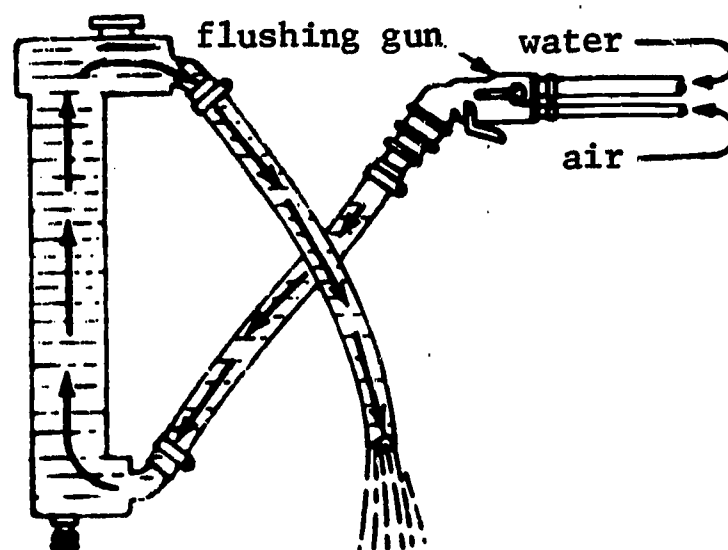

Fig. 11 Reverse flushing the radiator.

pump. This will provide an unobstructed outlet for the flushing stream, see Figure 12.

**THERMAL CONTROLS** - Most Cummins Engines are equipped with either high (170/185F) or low 160/175F), and in a few cases higher range (180/195F) thermostats, depending on engine application. The lower value indicates where the thermostat starts to open and the higher value where it is fully open. Check stamping on thermostat; install same range new thermostat as that removed.

The opening and closing of thermostats can be checked against a thermometer while immersed in water as the water is brought up to temperature by heating; see Figure 13.

**OTHER THERMAL CONTROLS** - Shutterstats for the radiator shutters must be kept set to operate in the same range as the thermostats with which they are used. The 180/195 F thermostats are used with shutterstats that are set close to 187 F and open at 195 F.

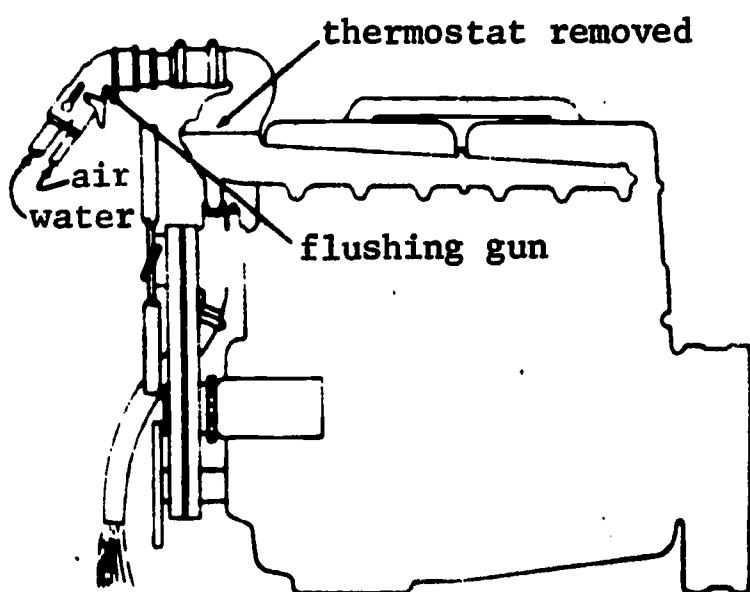

Fig. 12 Reverse flow flushing the engine water jacket.

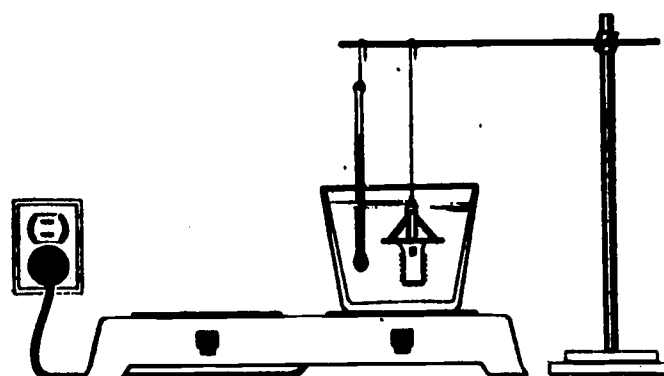

Fig. 13 Testing thermostat.

## II -- UNIT INSTALLATION -- TRANSMISSION

### SECTION A -- PREPARATION FOR INSTALLATION

This portion of the unit presents a step-by-step procedure necessary to follow when installing a No. 5960 or 6061 Allison transmission into Euclid 14 or 15 FFD trucks or Mack LYSD and M45 trucks. Many of these procedures apply to other type vehicles; check your maintenance manuals for differences. Some maintenance and safety precautions will be inserted throughout the procedure.

**PROPER ALIGNMENT** - Before mounting the transmission into the truck, there must be an alignment check between the engine flex plate and the flywheel housing. This operation is necessary to be sure the flywheel housing is centered properly with the engine crankshaft. This can be checked with a dial indicator. An allowance of .003 is acceptable in either direction. **CAUTION:** If the transmission is installed without the above check being made, and there is a misalignment in excess of .003, damage to the equipment may occur.

**NOTE:** Before proceeding with the next step, check overhead crane equipment for proper working condition.

Use overhead crane and lift rebuilt transmission from cart to transmission floor jack. Roll floor jack and transmission under unit.

### SECTION B -- INSTALLING TRANSMISSION

Raise the transmission into position, using the floor jack, and install rear cradle capscrews. Install capscrews mounting converter housing to flywheel housing.

Remove the transmission floor jack and engine jack or blocking. Install the top three mounting capscrews through the opening in the top of the converter housing. **NOTE:** Use new style lock plate to lock capscrews.



Install twelve capscrews fastening flex plate to flywheel. **CAUTION:** When installing flex plate capscrews, BE SURE they do not fall into the flywheel housing. Torque flex plate bolts to 100 foot pounds.

Install top cover plate on converter housing and floor plate in cab. Connect transmission shift linkage to selector valve and linkage to brake control valve. **NOTE:** Adjust the shift linkage.

Connect parking brake linkage and adjust for proper tension. Connect speedometer cable, converter, oil temperature gauge connection and clutch oil pressure gauge line.

Connect oil filter and cooler lines. **NOTE:** Be sure oil lines are free of cuttings and dirt. Also check for worn lines and fittings; replace where necessary.

Install rear driveline from transmission to differential. Check drivelines and "V" joint crosses for wear, and replace where necessary.

Replace transmission oil filter element and fill transmission with new oil. **NOTE:** Check the maintenance manual for oil specifications and capacity. Start engine and, with transmission in neutral, check transmission oil level.

Before road resting the truck, clean up work area and return all tools to their storage places.

**ROAD TEST** - When road testing the truck bring up to operating temperature, (minimum of 160 F and maximum of 250 F) and check for the following:

1. Clutch pressures with engine running at 1500 rpm should be 210 psi minimum to 250 psi maximum in first and reverse gears.
2. In second, third, fourth, fifth, and sixth gears, the pressures should be 140 psi minimum and 155 psi maximum.

Make adjustments or repairs if above tolerances are not achieved.

This has been a very brief outline of installing a transmission; more will be covered in detail in later units on this operation.

AM 1-16D  
4/27/66

## PRINCIPLES OF DIESEL ENGINE COOLING SYSTEMS

Human Engineering Institute  
+ MINN. STATE DEPT. OF ED.  
VOCATIONAL EDUCATION

Press A - 1 Check to see that timer is OFF

1

This lesson is designed to supplement Unit No. AM 1-15 class text, Maintaining the Cooling System - Cummins Diesel Engine, by asking questions not only on the Cummins Engine but on cooling systems in general.

Much has been said about engine cooling systems in past units. Since both the GM and Cummins cooling systems are similar in many respects, this lesson will differ from the others in that questions will be asked on material we have previously covered. However, if a question is answered incorrectly, the information will be repeated.

Press A - 2

1

An effective cooling system is required for high speed diesels because \_\_\_\_\_

- A. the system must carry away one-half the heat created by the engine. - 3
- B. the oil in the engine must be kept cool for effective operation. - 4
- C. there is intense heat created around the cylinders. - 5

1

No. You are incorrect. We said that between the air, oil, and cooling systems about one-third of the heat generated by the engine was carried away, not one-half.

Try this question again.

Press A - 2

1

No. That wasn't the answer. The lubricating air and cooling systems together help cool the engine. True, the coolant must keep the oil from getting too hot and breaking down - which results in poor lubrication, but the main purpose of an effective cooling system is to cool the hot area around the cylinders.

Press A - 5

1

OK. A pressurized cooling system is typical of high speed diesel engines in vehicles and trucks today. These pressurized systems cool the cylinders by \_\_\_\_\_

- A. radiation. - 6
- B. circulation. - 7
- C. absorption. - 8

1

No. You are incorrect. Radiation occurs when the coolant has absorbed heat from the cylinders and carries it to the radiator, where air passes over it and dissipates the heat. The air passing through the fins or core of the radiator actually removes the heat. This process gives us heat removal through radiation.

Press A - 8

1

No. You are confused. After the coolant absorbs heat from the cylinder walls it circulates to other parts of the cooling system, mainly the radiator. Air passes over the hot coolant as it circulates through the radiator core. As the air passes over the radiator core which contains the coolant, the air removes the heat through radiation.

Press A - 8

1

8

OK. We said that the radiator cools the heat loaded coolant through a process of radiation and circulation. What other component of the engine cools by these two processes?

- A. Water header. - 9
- B. Heat exchanger. - 11
- C. Corrosion resistor. - 10

1

No. You have chosen the wrong answer. The water header only distributes the cooled water to the cylinder jackets after it has been cooled by the radiator. Remember, we said the water header was a large drilling that extended the full length of the upper portion of the engine block.

Try this question again.

Press A - 8

1

9

10

No. The corrosion resistor is a water (coolant) conditioner not a heat remover. As the water passes through the conditioner, corrosive chemicals harmful to engine parts are neutralized. In addition, the harmful effect of electrolysis, caused by the rapid movement of the coolant is eliminated by the magnesium plate in the filter.

Press A - 11

1

OK. A heat exchanger performs the same function as the radiator, with one exception, and that is the heat exchanger can also \_\_\_\_\_ the liquid that is passing through it, whereas the radiator cannot.

- A. filter - 17
- B. heat - 14
- C. pressurize - 13

1

11

12

No. You are confusing water, oil and air filters with heat exchangers. Remember, we talked about the inter/after cooler or heater used on Cummins turbocharged engines. It cooled the incoming air to the cylinders in the summer by circulating water through tubes, with air passing over the tubes. In the winter, hot water passing through tubes heated the air.

Press A - 14

1

No. You are confusing a heat exchanger with a water pump. A heat exchanger can be used either as a cooler or as a heater, depending on the time of year, but it does not pressurize liquid moving through it.

Try this question again.

Press A - 11

1

13

14

OK. A heat exchanger can either cool or heat the liquid moving through it, whereas the radiator can only cool the liquid. The engine by-pass in a cooling system allows \_\_\_\_\_

- A. coolant to circulate through the radiator only. - 15
- B. coolant to circulate through the engine only. - 17
- C. excessive coolant created by high temperature to be drained off. - 16

1

No. The by-pass tube is to allow coolant to circulate through the engine, not the radiator. This allows the engine temperature to reach the desired temperature more quickly.

Press A - 17

1

15

16

No. You are confusing the overflow tube in the radiator with the by-pass tube. Remember, we said at low engine temperature, the thermostats are closed. This allows coolant to flow only through the engine. The purpose of this is to \_\_\_\_\_

- A. bring engine temperature up more quickly. -17
- B. give the engine oil a chance to lubricate the moving parts. -18
- C. give the radiator a chance to build up sufficient coolant pressure. 1

17

OK. The thermostats are closed when the coolant is at low temperature, allowing only engine coolant to circulate. This builds up engine temperature more quickly. When the thermostat (s) open, coolant flows from \_\_\_\_\_

- A. the bottom tank to the top tank of the radiator. -19
- B. the top tank to the bottom tank of the radiator. -21
- C. the top tank through the tubes to the water pump. -20

1

18

No. You are obviously confused about the cooling systems of diesel engines. It is suggested that you review the following units before going on with this lesson:

AM 1-4  
AM 1-4D  
AM 1-16

If you feel you know the material, and may do better by continuing with the lesson, PRESS B.

If you want to wait and continue this tape after reviewing the above material - PRESS REWIND.

B → 17

1

19

No. Coolant always flows from top to bottom in a radiator because the suction side of the pump pulls coolant from the bottom tank of the radiator. Also, because hot water has a lower specific gravity, which would make it rise, and counteract the flow if it flowed in at the bottom.

Press A - 21

1

20

No. Remember, the radiators we have discussed have a top tank and a bottom tank, with tubes and fins in between.

Press A - 21

1

21

OK. In a high speed diesel engine cooling system there is one component that allows the boiling point of the coolant to be raised, and permits somewhat higher engine operating temperatures without loss of coolant. This component is the \_\_\_\_\_

- A. thermostat. -23
- B. pressure cap. -24

X (C) - 22

1

22

You have answered one or more of the questions in this sequence of material incorrectly. Before going on, review this data again. Read carefully and think before you answer.

Press A - 2

1

23

No. The thermostat is only a means of stopping the flow of coolant through the radiator. The correct answer is: the pressure cap allows higher engine temperature without loss of coolant.

Press A - 24

1



24

OK. Most thermostats on heavy off-highway equipment start to open around \_\_\_\_\_ F and are fully open at \_\_\_\_\_ F.

- A. 150, 175 > 25
- B. 165, 170 > 25
- C. 175, 195 - 26

2

25

No. The correct temperatures on most thermostats of this type are from 175 to 195F. Ask your instructor to show the thermostat test in class.

Press A - 26

2

26

OK. A pressure cap has two valves; one allows pressure to build up in the system before opening (about seven pounds); the other opens under a vacuum condition during the cool down period to prevent \_\_\_\_\_.

- A. loss of coolant. - 27
- B. collapse of hoses. - 29
- C. the formation of additional scale. - 28

2

27

No. Loss of coolant may occur should the pressure valve fail to open. The boiling point and above would be reached in this case, and the coolant would escape through the overflow tube. It is a good idea to periodically check the pressure caps to be sure they are functioning properly.

Try this question again.

Press A - 26

2

28

No. You are incorrect. The formation of scale usually is caused by using hard water without a water conditioner, or by the oil losing its body and breaking down through overheating. A system often is neglected, too; this will form scale.

Try this question again.

Press A - 26

2

29

OK. Without the vacuum valve in a pressure cap, the coolant hoses may collapse and possibly other damage may occur if the engine is shut down when extremely hot. Engine manufacturers always recommend a waiting or cooling off period before complete engine shut down.

The Withnell radiator has an advantage over the standard equipment radiator in that it \_\_\_\_\_.

- A. has a larger cooling capacity. - 30
- B. is repaired more easily. - 32
- C. is shockproof. - 31

2

30

No. We said nothing about the cooling capacities of the two radiators. The answer we want here is the Withnell is much easier to repair because the tubes are replaceable, whereas the standard type requires a complete radiator replacement and welding job.

Press A - 32

2

31

No. Let's say the Withnell is more shockproof than the standard radiator, because the tubes of the Withnell are set in rubber grommets rather than rigidly welded to the top and bottom tank. However, the big advantage is the fact that repair is so much easier.

Press A - 32

2

32

OK. The ease of repair is the big advantage in using a Withnell radiator over the standard type radiator.

On Cummins cylinder liners, coolant is in direct contact with the liner (1) and (2) separates the coolant from the crankcase.

- A. (1) all around (2) a tight fit - 33
  - B. (1) upper half (2) an "O" ring - 34
  - C. (1) lower half (2) an "O" ring - 33
- 2

33

No. Remember, we said the liner is replaceable and coolant is in direct contact with the upper half, with an "O" ring separating the coolant (approximately half way down) from the crankcase.

Press A - 34

2

34

OK. Only the upper part or the hottest portion has coolant surrounding the liner.

Smaller oil pans on diesel engines are possible because

- A. of the new design of the oil coolers, - 35
  - B. of the circulating coolant through the oil cooler. - 37
  - C. of the high pressure oil system. - 36
- 2

35

No. The fact that an oil cooler exists at all eliminates the need for large oil pans. If it weren't for the oil cooler, oil would have to be cooled by radiation in the oil pan; hence, larger pans would be needed.

Press A - 37

2

36

No. Oil pressure has nothing to do with the oil being kept cool. Think, and try this question again.

Press A - 34

2

37

OK. If it were not for the oil cooler, with coolant passing through this heat exchanger (oil cooler), oil would have to be cooled by radiation in the oil pan; hence, larger oil pans would be needed.

The oil pressure is always greater in a diesel engine than the coolant pressure.

- A. True - 38
  - B. False - 39
- 2

38

NO. You are incorrect. Remember, the cooling system has the 7 lb. pressure cap plus 14.7 lb. atmospheric pressure. When the engine is idling, the oil pressure is low.

Press A, - 39

2

39

OK. Coolant getting into the oil causes many problems and is very critical because coolant mixing with oil will destroy the lubricating qualities of the oil and may ruin the engine. To prevent this, the drain cock on the oil cooler should be checked periodically to determine if there is water in the oil.

Coolant is circulated in a Cummins diesel engine by a pump.

- A. gear type - 40
  - B. internal gear type - 40
  - C. centrifugal type - 41
- 2

40

No. A gear type pump is used on the GM engine, but a Cummins engine uses a centrifugal type pump.

Press A - 41

2

41

OK. The Cummins uses a volute centrifugal type pump in which the volute refers to the

- A. capacity of the pump. - 42
- B. pump housing shape. - 44
- C. curved impeller action. - 43

2

42

No. The capacity of the pump has nothing to do with the definition of volute. If you will recall in AM 1-11D, and AM 1-15, we discussed the shape of the pump's casing. It is a progressively expanding passageway, which collects the water from the twirling impeller. This is the "volute".

Press A - 44

2

43

No. The curved impeller blades are not called the volute. True, the blades twirl inside the volute, which is the pump's housing. The volute refers to the housing shape. It is a progressively expanding passageway, which collects the water from the twirling impeller and centrifugally forces it from the outlet.

Press A - 44

2

44

OK. It is just as important to keep an engine from overheating as it is to keep one from overcooling. The thermostats and shutters control the desired temperature range. Low temperatures in an engine tend to

- A. cause poor lubrication due to heavy oil. - 46
- B. cause incomplete combustion. - 47

X(C) → 45

2

45

You have answered one or more of the questions in this sequence of material incorrectly. Review these questions and answers again and take your time before answering.

Press A - 24

2

46

You are partially correct. When the engine is first started, the oil has to warm up for proper lubrication. However, here we were assuming the engine has been running but that the temperature controls were malfunctioning. The answer is: incomplete combustion would occur.

Press A - 47

2

47

OK. Incomplete combustion is one of the results of overcooling an engine. The cylinder walls are not hot enough to activate combustion. This condition could cause

- A. an underfueling condition. - 48
- B. smoky exhaust and a reduction of horsepower. - 50
- C. a collapse of water hoses. - 49

3

48

49

No. It would be the opposite condition. There would be an overfueling condition. If the combustion was delayed or retarded, the unburned fuel would probably be escaping from the exhaust valves or running down the inside of the cylinder. This condition would result in smoky exhaust and loss of horsepower.

Press A - 50

3

No. Collapse of water hoses is caused by shutting down the engine when it is at high temperature. Remember, there should always be a waiting period and gradual decrease of rpm's when shutting down a diesel engine.

Press A - 50

3

50

51

OK. Smoky exhaust and loss of horsepower may be the result of overcooling an engine.

Let's discuss some engine problems as they are related to cooling system troubles.

Many times, when an engine is overheating it is not the fault of the cooling system. This is important to keep in mind when troubleshooting. For instance, high exhaust back pressure causes poor engine breathing. Again, there is poor combustion in the cylinders, and burning fule escapes from the exhaust valves into the exhaust manifold. This additional heat would then be transferred

- A. to the cylinder head. - 51
- B. to the water manifold. - 53
- C. to the radiator. - 52

3

No. The answer we want here is that the heat from the exhaust manifold would be transferred to the water manifold surrounding the exhaust manifold. The cylinder head would probably already be overheated.

Press A - 53

3

52

53

You are partly correct. The heat would be transferred to the radiator, but first it would be absorbed by the water manifold which surrounds the exhaust manifold; then it would be carried to the radiator.

Press A - 53

3

OK. The water manifold surrounding the exhaust manifold absorbs the excess heat and carries it to the radiator.

Excessive engine temperatures may also be caused by a thermostat being installed in reverse. This condition would result in

- A. no coolant circulation in the radiator. - 55
- B. no coolant circulation in the engine. > 54
- C. no coolant flow in the by-pass tube.

3

54

55

No. You are incorrect. Coolant would circulate through the engine and by-pass tube, but not through the radiator. It would be the same as if the thermostat were permanently closed. Engine circulating coolant would just keep rising and rising because the element that expands the thermostat from heating would be on the radiator side.

Press A - 55

3

OK. It would be the same as if the thermostat(s) were permanently closed. The heat from the engine coolant could not expand the element in the thermostat to open it, because the element would be immersed in the radiator coolant.

Should a leak occur in the lubrication system and oil enter the coolant, will this

- A. decrease rust prevention? - 56
- B. decrease heat transfer from metal to coolant? - 58
- C. lower the boiling point of the coolant? - 57

3



56

57

No. Oil does not mix with coolant; it travels separately in the coolant mixture. This condition would not decrease rusting in the engine parts.

No. The boiling point of coolant can be lowered in an engine only by removing the pressure cap and reducing the pressure within the system.

Try this question again.

Try this question again.

Press A - 55

Press A - 55

3

3

58

59

OK. Oil in the coolant would lower the heat transfer from metal to metal because the coolant could not work at its full capacity if it were diluted with oil.

No. Alcohol is not recommended for use in diesel engines because of its low boiling point, not because it might form rust and scale on coolant passages. The scale is produced by impurities in hard water being deposited on engine parts.

Formation of scale in engine coolant passages is usually caused by \_\_\_\_\_.

- A. using alcohol as anti-freeze. - 59
- B. combustion gases in the coolant. - 60
- C. using hard mineral water. - 61

Press A - 61

3

3

60

61

No. Combustion gases and air in the coolant system have nothing to do with scale formation on engine cooling passages; this is caused strictly from using water with impurities in it, which eventually build up scale and reduce engine cooling.

OK. Hard water, or water with impurities, forms scale on engine cooling passages.

To show how very critical scale on engine cooling passages can be, suppose we have a piece of steel one inch thick. A 1/16" coating of calcium on this one inch piece of steel will increase its thickness to the equivalent of 4 7/8" for purposes of heat being transferred through it.

Silicate deposits are even more critical because, for these deposits, this same ratio increases to 16" equivalent.

Press A - 61

Press A - 62

3

3

62

63

Rust inhibitors require changing periodically in the cooling system because they become contaminated and \_\_\_\_\_.

True, the coolant does become contaminated by loosening the rust particles; and these particles are then suspended in the solution. But the solution does not seek lower levels of cooling passages when it becomes contaminated.

- A. seek the lower cooling passages. - 63
- B. lose their effectiveness. - 65
- C. form scale in the cooling passages. - 64

Try this question again.

Press A - 62

3

3

64

65

No. Remember, we said that minerals, such as calcium and silicates, found in hard water form scale, not the rust inhibitors.

Try this question again.

Press A - 62

3

OK. Rust inhibitors lose their effectiveness by being contaminated with rust particles. This solution should be changed each spring and fall.

Coolant from the engine cooling system is circulated through the air compressor for the same reason it is circulated through the \_\_\_\_\_.

- A. turbocharger - 66
- B. engine - 68
- C. water pump - 67

3

66

67

No. The turbocharger is not water cooled; it is only lubricated by the engine lube system.

Try this question again.

Press A - 65

3

No. The water pump is the component that makes the engine cooling system pressurized. The answer we want here is engine, because an air compressor is basically an engine. It has a piston, rings, a crankshaft, etc. Remember, it runs constantly; and when air is compressed it creates great quantities of heat that must be carried away; hence, the coolant circulation.

Press A - 68

3

68

69

Right. The air compressor requires cooling, just as the engine does, because of the heat generated by compressing air.

Without a by-pass tube in a diesel cooling system there would possibly be engine seizure with the expansion occurring \_\_\_\_\_.

- A. in the lower half of the pistons. - 69
- B. around the ring area of the pistons. - 70
- C. uniformly throughout the entire engine. - 69

3

No. The lower portion of the engine would be cool compared to the upper half, due to the coolant not being able to circulate until the thermostats opened, which could be too late.

Press A - 70

3

70

71

OK. The hot area would be around the tops of the pistons, causing the expansion of the metal and possible seizure.

Another condition that can cause engine seizure is \_\_\_\_\_.

- A. high exhaust pressure. - 71
- B. formation of scale. - 73
- C. loss of a pressure cap. - 72

3

You are partially correct. High exhaust back pressure is usually caused by a restriction in the exhaust system. If this condition is allowed to continue, the coolant would heat up in the water manifold surrounding the exhaust manifold and could get hot enough to cause engine seizure. However, the answer we wanted here was: the formation of scale around the pistons. This prevents heat from being carried away from the piston liners, causing possible seizure.

Press A - 73

3

72

True. The pressure cap may lead to engine seizure eventually. If the engine is operating continuously, the coolant temperature may go beyond the small rise in boiling point which the 7 lbs. pressure allows it to make. The pressure cap then could fail, and allow the coolant to boil out, causing engine seizure from overheating.

However, the answer we wanted here was: the formation of scale around the piston coolant passages. This prevents heat from being carried away, causing possible piston seizure.

Press A - 73

3

73

OK. The formation of scale around piston coolant passages would probably cause piston seizure if allowed to continue building up.

For many years, engine manufacturers were confronted with the problem of metal pitting, particularly around the outside of the cylinder liners. After much research it was found to be caused by two conditions, both as a result of the mechanical wearing away of metal surfaces by action of the fluid. These conditions are: CAVITATION and ELECTROLYSIS. Electrolysis has been pretty well checked by the use of a water conditioner which we discussed earlier.

Press A - 75

4

x (c) → 74

73 1/2

74

For many years, engine manufacturers were confronted with the problem of metal pitting, particularly around the outside of the cylinder liners. After much research it was found to be caused by two conditions, both as a result of the mechanical wearing away of metal surfaces by action of the fluid. These conditions are: CAVITATION and ELECTROLYSIS. Electrolysis has been pretty well checked by the use of a water conditioner which we discussed earlier.

Press A - 75

4

You have answered one or more of the questions in this section incorrectly. Read them over again, and think carefully before answering.

Press A - 47

4

75

76

Cavitation is caused by the fluid leaving the metal guiding surface, such as in the impeller of a water pump. When the fluid leaves the surface, a vacuum is formed, into which air and fluid vapor are liberated from the fluid to form a bubble. This bubble is carried along with the fluid into an area of high pressure where the bubble suddenly collapses (implosion) and may develop a pressure of several thousand pounds per square inch to compress the air in the bubble. This pressure may be sufficiently high to drive the particle of air into the metal, causing pitting.

Press A - 76

4

When this action is repeated in rapid succession the metal is actually worn away, and other mechanical effects may be produced, such as noisy operation and vibration due to the repeated blows of the collapsing bubbles.

A solution that helps to retard implosion and pump cavitation is the use of pressurized cooling systems. This makes it more difficult for the fluid to part from the metal surfaces.

Press A - 77

4

77

78

Cavitation could be described as a \_\_\_\_\_

- A. condition where high pressure exists, like -78 in a water pump.
- B. situation where tremendous pressure builds up on the pump outlet due to a restriction. -79
- C. condition where liquid does not entirely fill the existing space. -80

4

No. High pressure is associated with water pumps on the outlet side. This has little to do with pump cavitation.

Try this question again after reviewing the last few frames.

Read carefully.

Press A - 73 1/2

4

79

80

No. A condition such as this is critical, though, and may damage the pump. However, this is not the meaning of cavitation. Answer this question again after reading the last few frames again.

Right. When the pump is running at high speeds, there is some pressure drop. In other words, the fluid is struggling to fill the spaces created by the turning impeller. Cavitation takes place when the fluid cannot fill these spaces rapidly enough.

Read carefully.

Implosion is the result of \_\_\_\_\_

Press A - 73

- A. bubbles formed by vacuum bursting under pressure. - 81
- B. bubbles formed by pump cavitation collapsing under pressure. - 83
- C. too much space for the liquid to fill. - 82

81

82

No. The bubbles do not burst, they collapse. This is the opposite of explosion; it is implosion.

No. This is not implosion; it is pump cavitation. The fact that liquid cannot fill the space created by the impeller results in the formation of the bubbles. The collapsing of the bubbles is implosion.

Press A - 83

Press A - 83

83

84

Correct.

Actual pitting of the metal of the cylinder walls takes place as a result of \_\_\_\_\_

No. We talked of the impurities of the water forming scale consisting of calcium and silicates, but not causing pitting of the metal. The answer we wanted here is: pitting around the outside of the cylinder liners is caused by cavitation and the collapsing bubbles in the high pressure areas.

- A. impurities in the water. - 84
- B. the fluid traveling from the pump to the engine passages under pressure. - 85
- C. the fluid with vacuum bubbles hitting the high pressure area. - 86

Press A - 86

85

86

No. In all pressurized cooling systems the coolant travels under pressure from the pump to the engine coolant passages. The answer we wanted here was: the fluid with vacuum bubbles hitting the high pressure area causes implosion of the bubbles and pitting of the metal around the high pressure areas.

Right. Pitting around the outside of the cylinder liners is caused by implosion of the bubbles, caused by pump cavitation.

Another condition that may increase pump cavitation is restriction in the inlet side of the pump, which would offer a resistance to the flow of coolant to the inlet side. In other words, should there be a restriction, the flow could not meet the intake capacities of the pump.

Press A - 86

This is why it is so important to maintain a clean cooling system, free from rust and other foreign material that could damage the equipment.

Press A - 87



# DIDACTOR

FILM NO. AM 1-15D  
4/27/66

87

88

This completes the material on cooling systems, particularly the Cummins cooling system. Remember, the cooling system is one of the four flows in a diesel engine and if one of these four fails, the equipment is out of commission.

PRESS REWIND

x(c) → 88

You have answered one or more of the questions in this section incorrectly. Read them over again, and think carefully before answering.

Press A. → 73

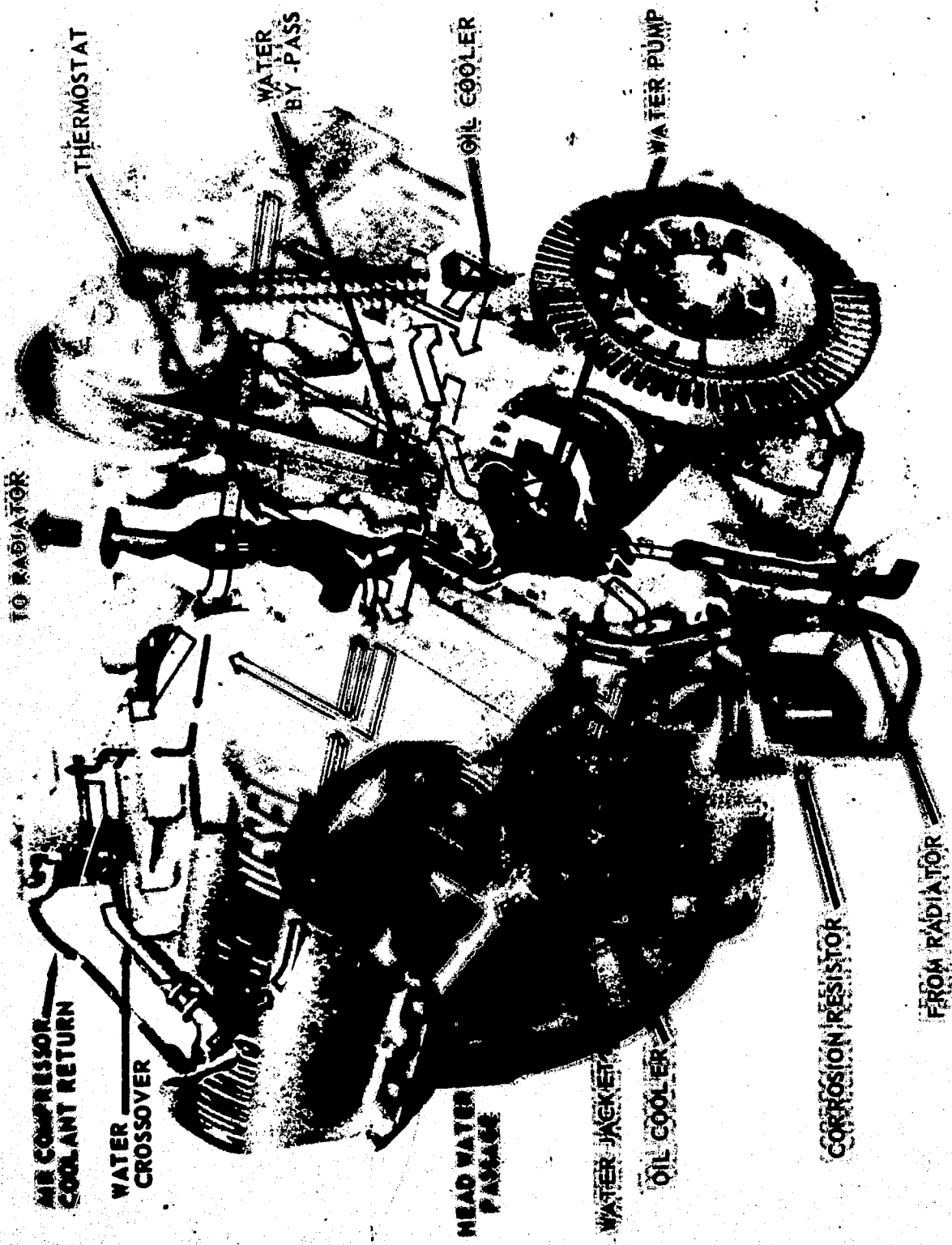

AM-15 (1)

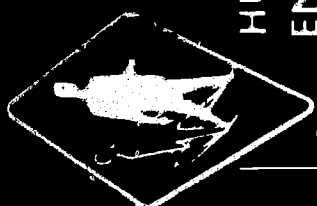

HUMAN  
ENGINEERING  
INSTITUTE

2341 Carnegie Ave  
Cleveland, Ohio 44115

®

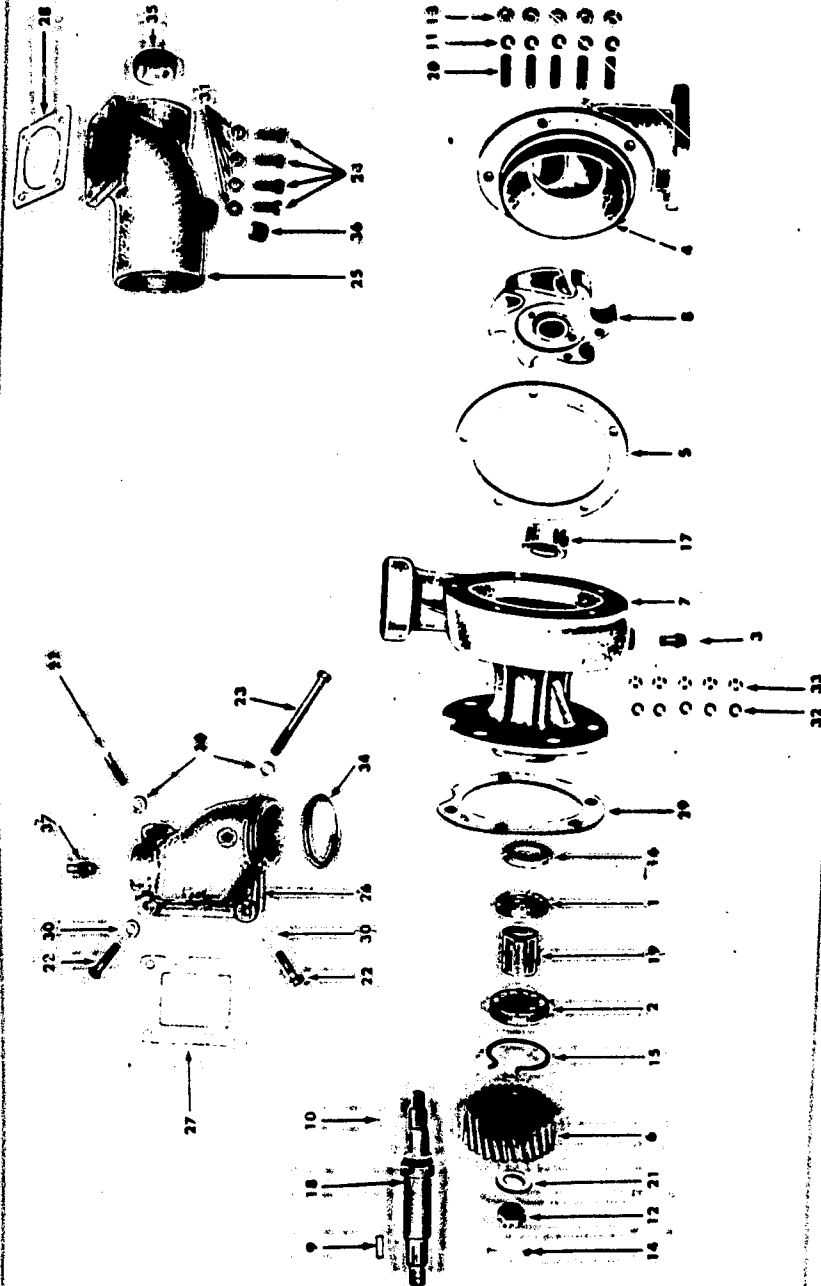

Fig. 59 NVH-12 and VT-12 Series Water Pump

- 1. Ball Bearing
- 2. Ball Bearing
- 3. Drain Cock
- 4. Water Pump Body Cover
- 5. Water Pump Body Gasket
- 6. Water Pump Gear
- 7. Water Pump Housing
- 8. Water Pump Impeller
- 9. Woodruff Key
- 10. Woodruff Key

- 11. Water Pump Cover Lockwasher
- 12. Water Pump Shaft Nut
- 13. Water Pump Cover Nut
- 14. Cotter Pin
- 15. Snap Ring
- 16. Water Pump Oil Seal
- 17. Water Pump Seal
- 18. Water Pump Shaft
- 19. Water Pump Spacer
- 20. Water Pump Cover Stud

- 21. Water Pump Shaft Washer
- 22. Connection Cap Screw
- 23. Connection to Block Cap Screw
- 24. Inlet Connection to Pump Cover Cap Screw
- 25. Water Pump Inlet Connection
- 26. Water Pump Outlet Connection
- 27. Connection to Block Gasket
- 28. Water Inlet Gasket
- 29. Pump to Gear Housing Gasket
- 30. Connection to Block Lockwasher

- 31. Inlet-to-Pump Cover Lockwasher
- 32. Pump-to-Gear Housing Lockwasher
- 33. Pump-to-Gear Housing Nut
- 34. Water Outlet Connection Packing
- 35. Pipe Plug
- 36. Pipe Plug
- 37. Pipe Plug

AW 1-15-2

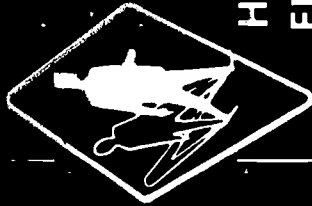

HUMAN  
ENGINEERING  
INSTITUTE

2341 Carnegie Ave  
Cleveland, Ohio 44115







## INSTRUCTOR'S GUIDE

I - Maintaining the Cooling System  
Cummins Diesel Engine

AM 1-15

Title of Unit: II - Unit Installation - Transmission

4/26/66

**FIRST:** Be sure all questions have been answered that students might have on home study units.

---

### OBJECTIVES:

1. To introduce the Cummins cooling system by discussing why it is so necessary for maintenance mechanics to keep the system in top working order.
2. To get the student acquainted with terms like circulation, radiation, control and how these terms relate to the cooling system.
3. To discuss cooling system components and how to evaluate system failures.
4. To give the student a brief look at installing a transmission.

---

### LEARNING AIDS suggested:

**WALL CHARTS:** Bulletin No. 983496 - Cummins V6/V8 Coolant Flow  
Bulletin No. 983414 - Coolant Flow/Thermostat Statistics  
Bulletin No. 983417 - Coolant Flow with Expansion Tank

**VUE CELLS:** AM 1-4 (6) Thermostat Operation  
AM 1-4 (7) Radiator - Shutter Arrangement  
AM 1-4 (8) Radiator Pressure Control Cap  
AM 1-15 (1) Coolant Flow Through a Cummins Engine  
AM 1-15 (2) Disassembled V12 Water Pump  
AM 1-15 (3) Centrifugal Pump

**MODELS:** Any components of the Cummins Cooling System would be beneficial to bring into class. Items such as: water pump, thermostat, water filter, corroded water hose, pressure cap, etc.

**NOTE:** Instructor can conduct the thermostat test in class if desired.

**QUESTIONS FOR DISCUSSION AND GROUP PARTICIPATION:**

1. Why is the cooling system so important in a diesel engine?
2. What effect will excessive heat have on the lubricating system?
3. How can overcooling cause ignition delay?
4. Approximately how much heat is carried away from an engine by the oil, air, and cooling system? Where does the rest go?
5. What is meant by circulation, radiation, and control in relation to the cooling system?
6. What type of cylinder liners do Cummins engines use? Explain.
7. What is the purpose of the water header? Where is it located?
8. Where is the water manifold located? How can it be distinguished from water header?
9. How are thermostats identified?
10. How does a Withnell radiator differ from standard equipment? What are the advantages of this type radiator?
11. Does the Cummins water pump have curved impeller blades?
12. What is the purpose of a water filter? What could happen to an engine with hard water in the cooling system and no water conditioner?
13. Why is it important to periodically check the exhaust pressure?
14. What is an air pocket in the cooling system? How will an air pocket affect the water pump?
15. Why is flushing the radiator important?
16. When do you use a dial indicator in transmission installing? Explain.
17. What do you test for when road testing a truck after installing a rebuilt transmission?