

R E P O R T R E S U M E S

ED 021 084

VT 005 667

AUTOMOTIVE DIESEL MAINTENANCE 1. UNIT XIII, I--MAINTAINING
THE FUEL SYSTEM (PART III), CUMMINS DIESEL ENGINES,
II--RADIATOR SHUTTER SYSTEM.

HUMAN ENGINEERING INSTITUTE, CLEVELAND, OHIO

REPORT NUMBER AM-1-13

PUB DATE 15 MAR 66

EDRS PRICE MF-\$0.50 HC-\$2.40 58P.

DESCRIPTORS- *STUDY GUIDES, *TEACHING GUIDES, *TRADE AND
INDUSTRIAL EDUCATION, *AUTO MECHANICS (OCCUPATION), *DIESEL
ENGINES, ADULT VOCATIONAL EDUCATION, TRANSPARENCIES,
PROGRAMED MATERIALS, INDIVIDUAL INSTRUCTION, INSTRUCTIONAL
FILMS, PROGRAMED INSTRUCTION, MOTOR VEHICLES, EQUIPMENT
MAINTENANCE,

THIS MODULE OF A 30-MODULE COURSE IS DESIGNED TO DEVELOP
AN UNDERSTANDING OF THE CONSTRUCTION, OPERATION, AND
MAINTENANCE OF THE DIESEL ENGINE FUEL AND RADIATOR SHUTTER
SYSTEMS. TOPICS ARE (1) MORE ABOUT THE CUMMINS FUEL SYSTEM,
(2) CALIBRATING THE PT FUEL PUMP, (3) CALIBRATING THE FUEL
INJECTORS, (4) UNDERSTANDING THE SHUTTER SYSTEM, (5) THE
SHUTTER, (6) SHUTTER CONTROL CYLINDER, AND (7) SHUTTER
CONTROL VALVE. THE MODULE CONSISTS OF A SELF-INSTRUCTIONAL
BRANCH PROGRAMED TRAINING FILM "OPERATION OF THE CUMMINS PT
FUEL SYSTEM COMPONENTS" AND OTHER MATERIALS. SEE VT 005 655
FOR FURTHER INFORMATION. MODULES IN THIS SERIES ARE AVAILABLE
AS VT 005 655 - VT 005 684. MODULES FOR AUTOMOTIVE DIESEL
MAINTENANCE 2" ARE AVAILABLE AS VT 005 685 - VT 005 709. THE
2-YEAR PROGRAM OUTLINE FOR "AUTOMOTIVE DIESEL MAINTENANCE 1
AND 2" IS AVAILABLE AS VT 006 006. THE TEXT MATERIAL,
TRANSPARENCIES, PROGRAMED TRAINING FILM, AND THE ELECTRONIC
TUTOR MAY BE RENTED (FOR \$1.75 PER WEEK) OR PURCHASED FROM
THE HUMAN ENGINEERING INSTITUTE, HEADQUARTERS AND DEVELOPMENT
CENTER, 2341 CARNEGIE AVENUE, CLEVELAND, OHIO 44115. (HC)

STUDY AND READING MATERIALS

AUTOMOTIVE DIESEL MAINTENANCE

1

I -- MAINTAINING THE FUEL SYSTEM (Part III)
CUMMINS DIESEL ENGINES

II -- RADIATOR SHUTTER SYSTEM UNIT XIII

TABLE OF CONTENTS

PART I

SECTION A

MORE ABOUT THE CUMMINS
FUEL SYSTEM

SECTION B

CALIBRATING THE PT FUEL
PUMP

SECTION C

CALIBRATING THE FUEL
INJECTORS

PART II

SECTION A

UNDERSTANDING THE SHUTTER
SYSTEM

SECTION B

THE SHUTTER

SECTION C

SHUTTER CONTROL CYLINDER

SECTION D

SHUTTER CONTROL VALVE

AM 1-13

3-15-66

U.S. DEPARTMENT OF HEALTH, EDUCATION & WELFARE
OFFICE OF EDUCATION

THIS DOCUMENT HAS BEEN REPRODUCED EXACTLY AS RECEIVED FROM THE
PERSON OR ORGANIZATION ORIGINATING IT. POINTS OF VIEW OR OPINIONS
STATED DO NOT NECESSARILY REPRESENT OFFICIAL OFFICE OF EDUCATION
POSITION OR POLICY.

HUMAN ENGINEERING INSTITUTE

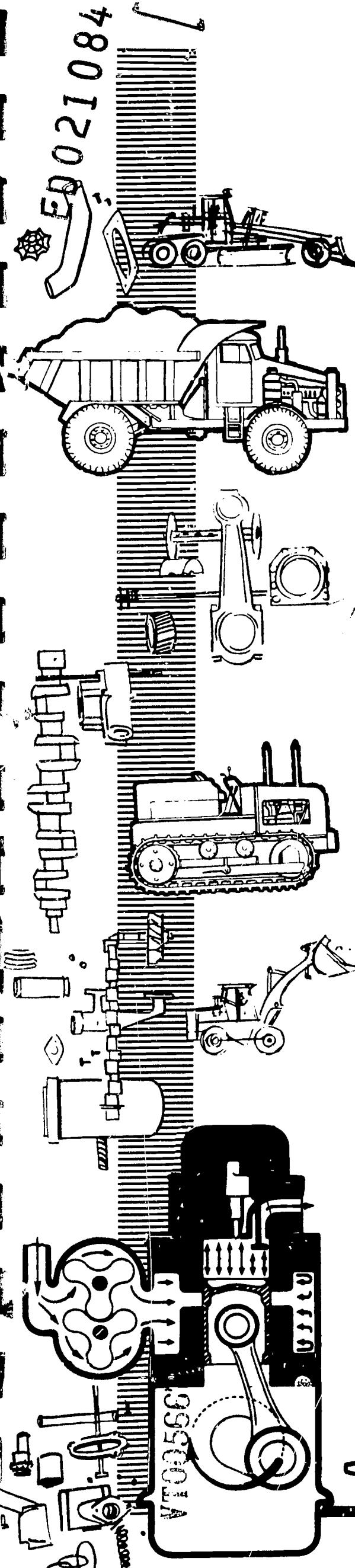

This unit is divided into two parts. The first section continues with the discussion of the Cummins fuel system, emphasizing testing and calibrating the fuel pump and injectors. The second half of the unit discusses operation and troubleshooting of the radiator shutter system.

I -- MAINTAINING THE FUEL SYSTEM (Part III) CUMMINS DIESEL ENGINE

SECTION A -- MORE ABOUT THE CUMMINS FUEL SYSTEM

In this last of a series of three units about the Cummins Diesel fuel system, we will review some of the important functions of the system emphasizing the Idling and High Speed mechanical governor (PTR type). Also, we will discuss the procedures required for adjusting and calibrating the system. Adjustment and calibration are the same for the PTR type as for the PTG type.

NOTE: For comparison between the PTG and PTR type pump, see AM 1-11.

GEAR PUMP -- The gear pump is located at the rear of the fuel pump and is driven by the engine through the main shaft of the fuel pump. The gear pump consists of a set of gears to pick up and deliver fuel throughout the fuel system. The gears transfer the fuel by carrying it between the teeth, around the sides of the body to a discharge hole. The faster the gear pump is driven, the greater the volume of fuel delivered. From the gear pump, fuel flows through the filter screen.

Gear pump pressure can be measured at the small plug fitting at the rear of the pump.

FILTER SCREEN AND MAGNET -- Fuel enters the filter screen cavity at the opening in the bottom of the screen then flows around the magnet,

through the screen, and down to the pressure regulator. The magnet prevents passage of ferrous particles into the fuel system.

PRESSURE REGULATOR -- The pressure regulator (PTR only) can be referred to as a by-pass valve. Its primary function is to control fuel manifold pressure at the gear pump.

To control the manifold pressure, the pressure regulator:

1. Provides for an adjustment of manifold pressure.
2. Compensates for changes in fuel oil temperature.
3. Provides for engine torque characteristics.
4. Prevents excessive gear pump pressures.
5. Compensates for gear pump wear.

CONTROLLING FUEL MANIFOLD PRESSURE -- If the injectors were subjected to the total fuel output of the gear pump, the fuel delivered to the injectors would be far in excess of the engine's requirements. See the total gear pump fuel delivery curve in Figure 1(a).

The pressure regulator controls and limits the gear pump fuel pressure through a by-pass system. The fuel pressure by-pass system by-passes part of the total gear pump fuel delivery to the suction side of the gear pump and fuel body. This limits fuel delivery to the required amount.

The pressure regulator assembly controls and limits gear pump fuel delivery by the valve action of the by-pass valve sleeve and by-pass valve plunger. The by-pass valve spring resists movement of the valve plunger in the valve sleeve.

The plunger, with drilled by-pass holes, slides inside the valve sleeve. If the by-pass valve spring holds the plunger all the way in the sleeve, all by-pass holes are sealed, preventing fuel from passing to the suction side of the gear pump. Increased fuel pressure in the gear pump forces

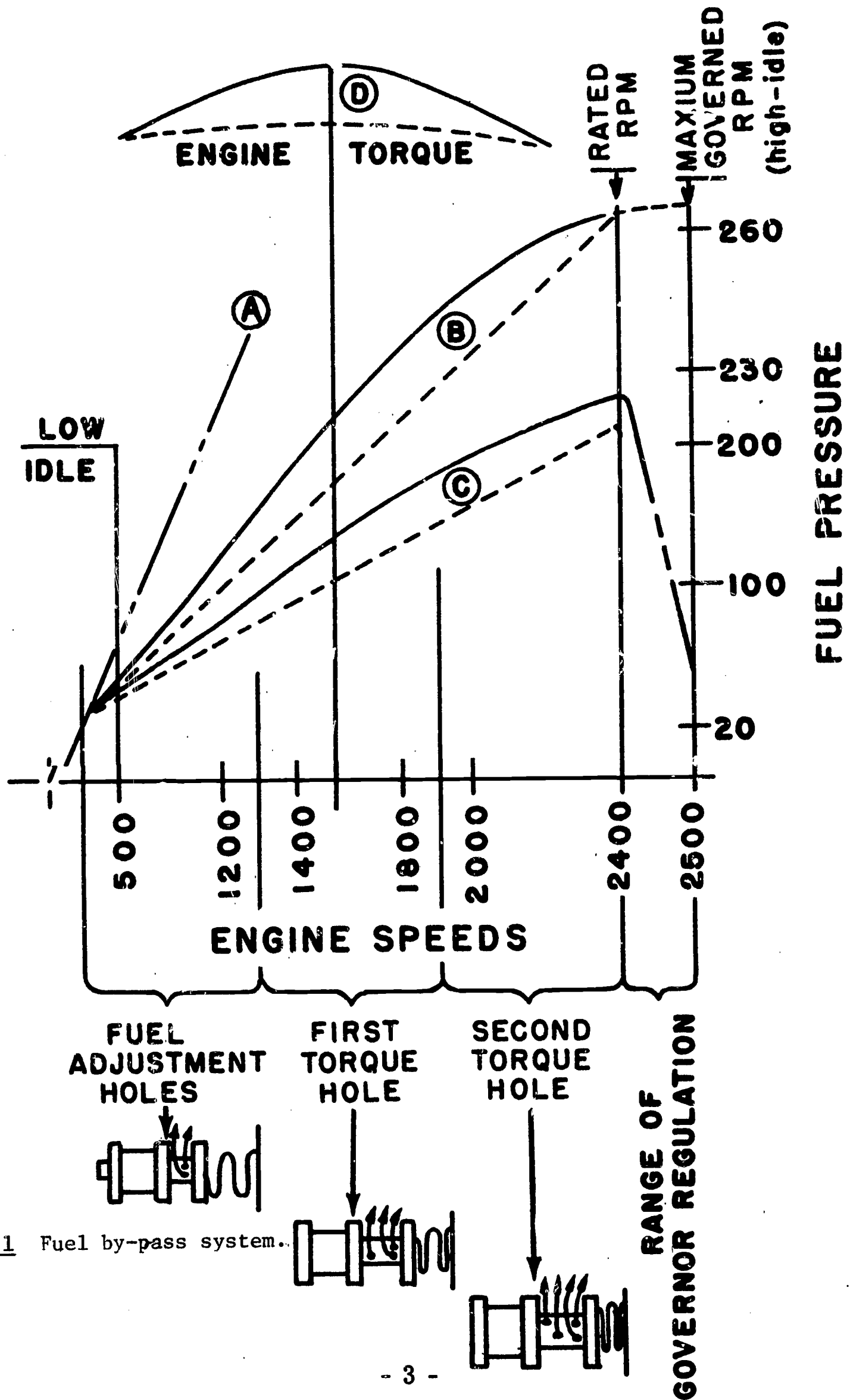

Fig. 1 Fuel by-pass system.

the plunger to move into the valve sleeve against the resisting spring force. Plunger movement opens some of the by-pass holes, returning fuel to the suction side of the gear pump.

There are three types of by-pass holes located in most plungers; (See Figure 2):

- (A) Fuel adjustment holes to regulate fuel manifold pressure.
- (B) Torque holes for engine torque characteristics.
- (C) Pump holes to prevent excessive gear pump pressures.

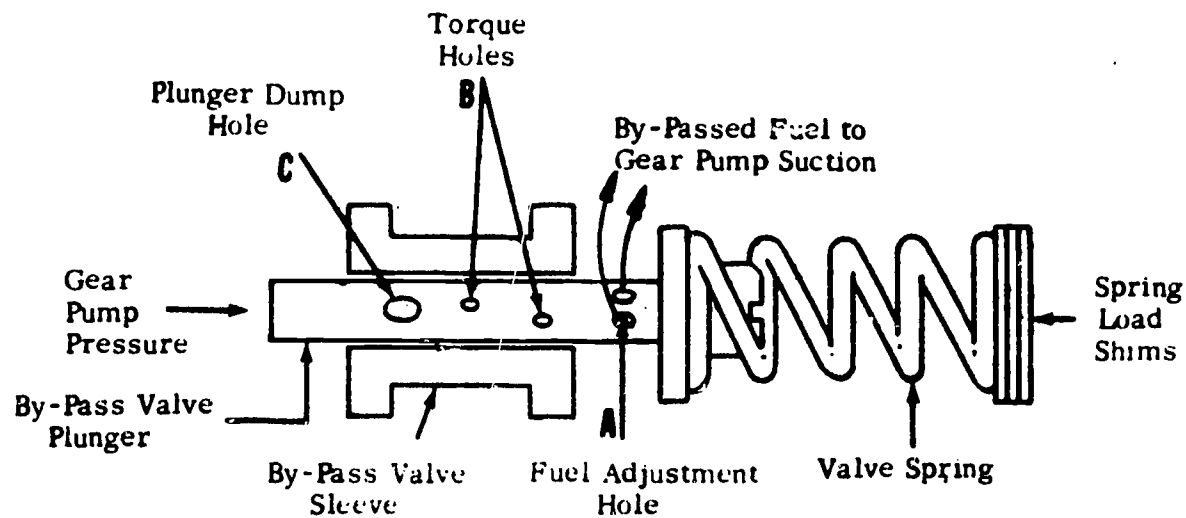

Fig. 2 Pressure regulator by-pass valve.

The fuel adjusting holes are first to appear and are evenly spaced around the plunger, immediately next to its shoulder. The dump holes appear last and are the large holes near the end of the plunger. The torque holes depend upon the engine application and cannot be described by number, size, or location, except that they are located between the fuel adjustment and dump holes.

FUEL MANIFOLD PRESSURE ADJUSTMENT -- The fuel adjusting plunger is a nylon plunger located in the end of the by-pass valve plunger; (See Figure 3). It is held in place by a cap and lock washer. Fuel pressure is adjusted by the amount the plunger covers the fuel adjusting holes.

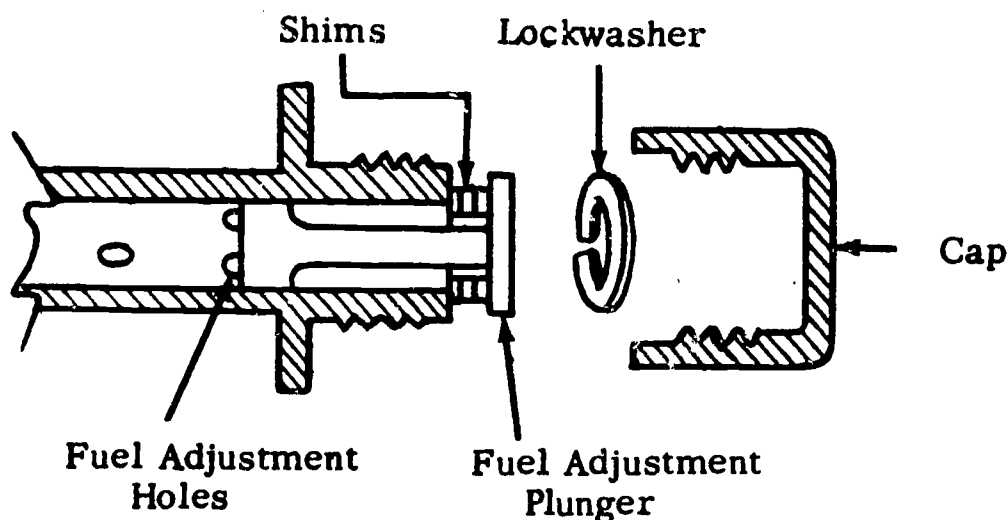

Fig. 3 Fuel adjust plunger.

Shims placed under the head of the plunger limit the distance the plunger projects into the by-pass valve plunger; (See Figure 3). Adding shims increases the exposed area of the fuel adjusting holes, thereby reducing fuel manifold pressure. Conversely, removing shims will increase fuel manifold pressure. Adjust fuel pressure on the engine at rated speed and full engine load.

At maximum rated speed and horsepower, only the fuel adjustment and torque by-pass holes are exposed. The dump holes are still closed under the edge of the valve sleeve.

FUEL OIL TEMPERATURE CHANGE -- The fuel adjusting plunger contracts and expands as fuel temperature changes. Fuel pressure thus changes to compensate for differences in fuel flow due to temperature.

TORQUE BY-PASS HOLES -- Figure 1 shows fuel pressure curves in relation to engine speeds. The chart can be used to explain the fuel pressure by-pass system for controlling torque characteristics. **NOTE:** The information shown only approximates these conditions and must not, in any way, be used as information pertaining to a particular engine.

The "Fuel Pressure By-Pass System" chart is a composite of fuel pressure engine speed, and torque characteristics. Note that rated engine speed is the speed which maximum fuel pressure is adjusted and the speed where maximum horsepower is attained.

SOLID LINES represent a fuel pressure curve and the resulting engine torque curve when the by-pass plunger exposes a series of torque by-pass holes (see by-pass plunger in chart). The sharp rise in engine torque is indicated by the solid line torque curve, which is indicative of the fuel by-passed by the torque holes.

Curve "A": The total gear pump pressure curve indicates resulting fuel pressure if no fuel was allowed to by-pass.

Curve "B": Represents the change in fuel pressure with respect to engine speed measured at the gear pump.

Curve "C": Represents the change in fuel manifold pressure with respect to engine speed.

Curve "D": Represents the resulting engine torque curve.

DOTTED LINES represent fuel pressure curves and the resulting engine torque curve when the by-pass plunger is equipped with fuel adjusting and dump holes but no torque holes. The shape of the dotted torque curve shows negligible torque rise and is indicative of this by-pass valve plunger design.

Curve "B" is a result of pressure regulator control over total gear pump pressure, Curve "A". Curve "C" is a result of the drop in gear pump fuel pressure (Curve "B") as it flows through the fuel pump. This is fuel manifold pressure. Both curves originate from the point of sufficient gear pump pressure to open the fuel adjustment by-pass holes and form a diverging pattern to the engine's governed speed.

Fuel manifold pressure is used for fuel pump calibration but it is also important to note the significance of the gear pump pressure curve. Note the similarity between the two curves. Fuel pump misadjustments and malfunctions will change the normal characteristics of the two curves.

ENGINE TORQUE CHARACTERISTICS -- The torque holes, in the by-pass valve plunger, control the fuel manifold pressure curve. This fuel manifold pressure control gives the engine desired torque rise.

Engine applications requiring torque rise use a by-pass plunger with one or more torque holes. The size and location of the torque holes determine the general shape of the torque curve and fuel pressure curve. The torque holes cause pressure changes at various points along the

manifold fuel pressure curve. These changes in pressure result in the solid line fuel pressure curves. Note the difference in the amount of fuel pressure between the solid and dotted lines of Curves "B" and "C" for each change in engine speed; (See Figure 1).

Refer to the solid line Curve "C" at maximum fuel pressure, rated speed, full engine load, and full throttle. These are the engine conditions where fuel pressure is adjusted and the fuel adjustment and torque holes are open to by-pass fuel. Increasing engine load without changing throttle position will cause the engine speed to decrease from rated speed. As engine speed decreases, fuel pressure decreases and the pressure regulator spring forces the plunger to slide through the valve sleeve. Continued decrease in fuel pressure and plunger movement allows the first torque hole, Figure 4, to slide under the edge of this sleeve, stopping fuel from by-passing through this hole. In Figure 1 this occurs between 2000 and 1800 rpm. If fuel can no longer by-pass from this hole, it will cause a rise in fuel pressure.

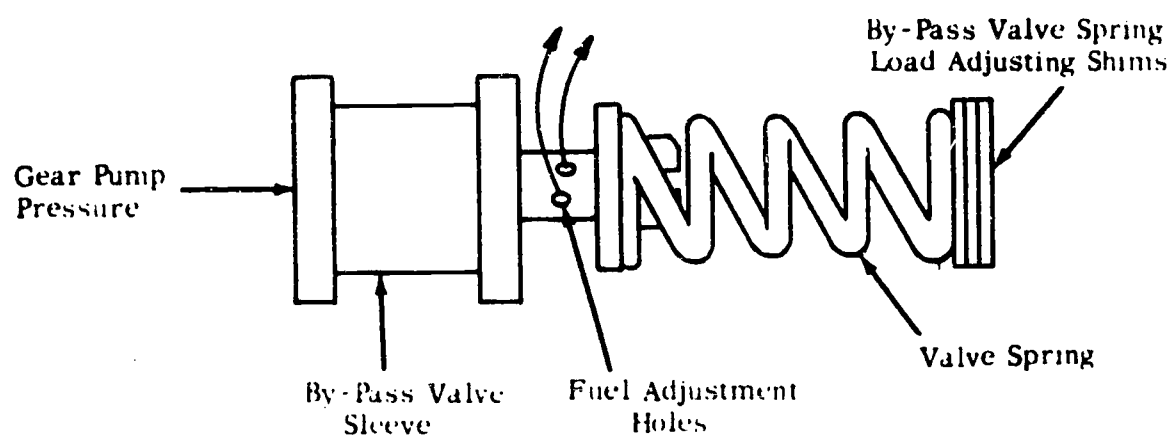

Fig. 4 First torque hole closed.

Continued increase in engine load decreases engine speed and fuel pressure, causing the second hole to close between 1200 and 1400 rpm and the fuel pressure to drop; (See Figure 5).

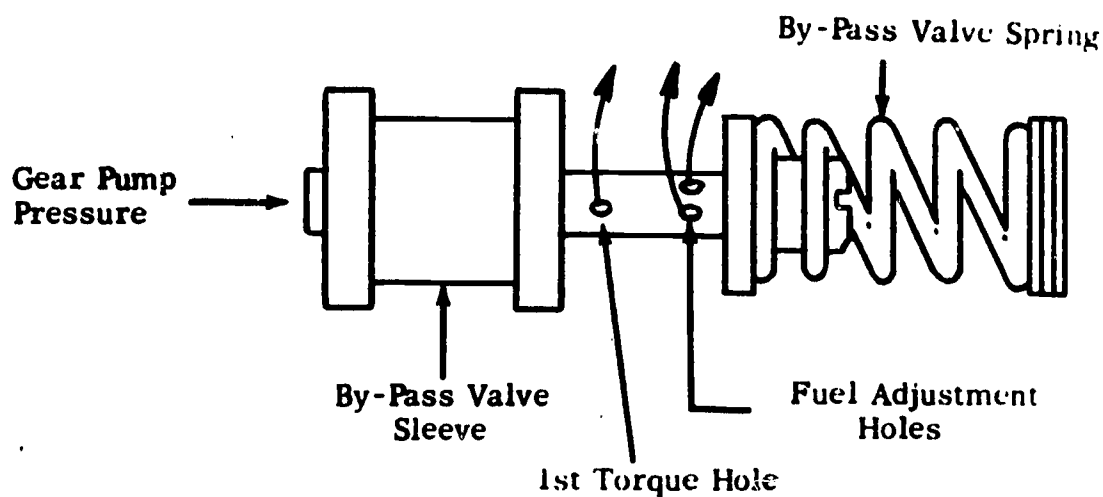

Fig. 5 Second torque hole closed.

The solid line indicates closing the torque holes, which holds fuel pressure above the dotted line during each change in engine speed. Note these results in the torque Curve "D".

Figure 1 shows a range of speeds where the by-pass holes are in position to by-pass fuel. These holes must be in position to open and close, at the engine speeds indicated, to produce the manifold pressure and torque curve indicated. The fuel pressure and resisting spring force both act to position the by-pass valve plunger. Resisting spring force can be adjusted by placing shims behind the spring. Proper spring load adjustment correctly positions the by-pass valve plunger to by-pass fuel through each

hole at the desired speeds. If the spring load is not properly adjusted, the torque holes do not open or close at desired speeds. This produces a new torque curve with a peak torque at an undesired rpm.

NOTE: These adjustments are extremely critical and vary with different size engines. Refer to the maintenance manual and calibration charts for correct fuel pump color coding, indicating specified pumps for different size engines.

EXCESSIVE GEAR PUMP PRESSURE -- When excessive gear pump pressure occurs, the plunger dump holes open, by-passing large amounts of fuel at the suction side of the gear pump; (See Figure 6). At rated engine

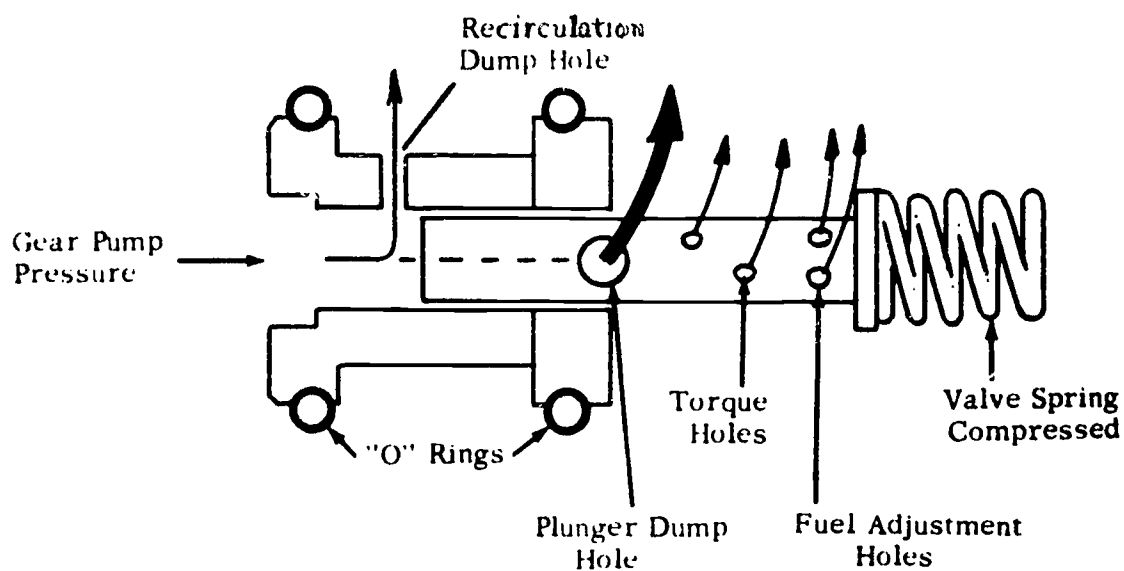

Fig. 6 Recirculating and dumping fuel.

speed the dump holes are closed and fuel not by-passed flows through the throttle shaft. If the engine is being driven by the load, such as "down-hill"

operation, the throttle is closed and the fuel flow to the injectors is stopped at the throttle shaft. The gear pump continues to turn, causing a rise in pressure at the pressure regulator. This pressure moves the by-pass valve plunger, opening the dump holes, allowing excess fuel to be by-passed to the suction side of the gear pump. This by-passed fuel limits the maximum gear pump pressure, and prevents damage to the gear pump.

THROTTLE SYSTEM -- The throttle system is an external, manual means of restricting or interrupting the fuel flow to the injectors; (See Figure 7).

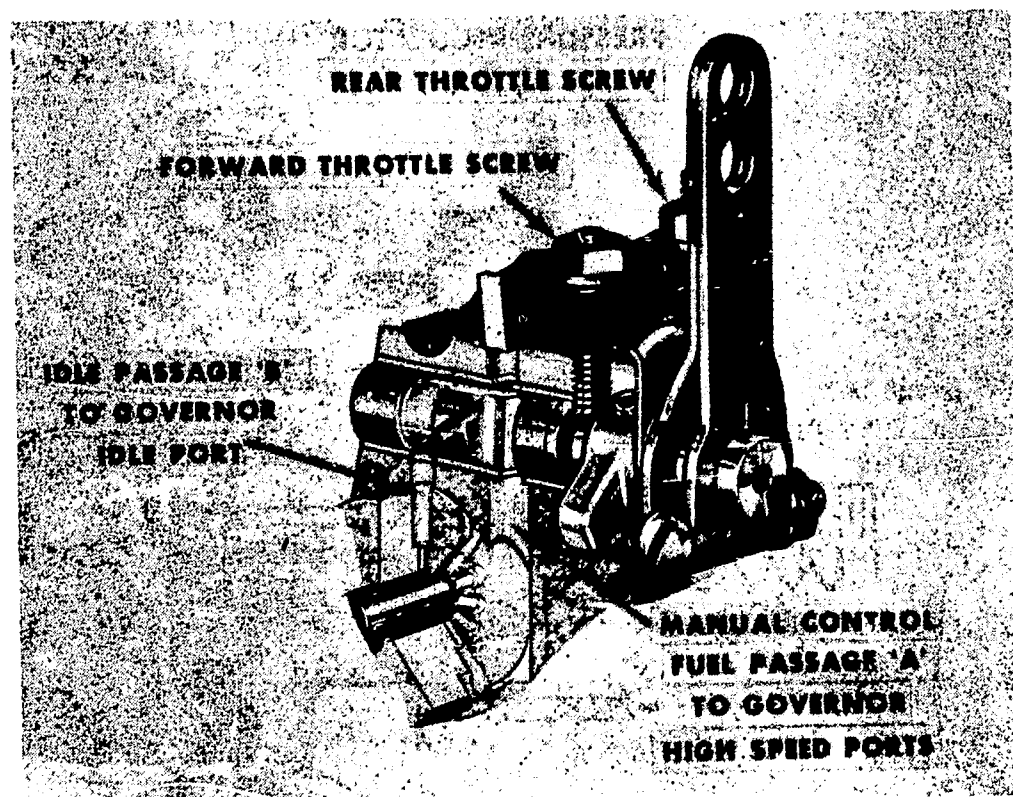

Fig. 7 Fuel pump throttle.

The throttle system:

1. Forms the idle fuel passageway.
2. Controls fuel flow for selecting desired engine speed.
3. Controls minimum circulation to the injectors (throttle leakage).

Fuel from the pressure regulator can flow through the throttle shaft to the governor. The shaft has two fuel passages, one leads to the governor idle fuel port, the other to the governor high speed fuel ports and injectors.

Idle fuel flow is controlled by the governor. The throttle shaft idle passage is always open to fuel pressure.

Manual fuel control passage -- Fuel required for engine operation must pass through the throttle shaft. The passage in the pump body and throttle shaft are aligned at this time by rotating the throttle shaft. Misalignment of passages restricts fuel flow reducing fuel manifold pressure available to the injectors. Two throttle stops limit throttle movement. The rear throttle stop screw allows adjustment of maximum fuel passage opening (wide open position). The forward throttle stop screw limits the closed throttle position.

SECTION B -- CALIBRATING THE PT FUEL PUMP

CALIBRATING THE PT PUMP -- The fuel pump can be calibrated while attached to the engine, or removed from the engine and calibrated on a test stand. The latter procedure is recommended, if possible, because this permits the pump to be calibrated without other fuel system components affecting the calibration.

The following steps are common to the test stand or engine calibration:

- A. Preliminary checks
 - 1. Check fuel oil temperature.
 - 2. Set approximate governor speed.
 - 3. Set pressure regulator spring load.
- B. Fuel manifold pressure
 - 1. Set rear throttle stop screw.
 - 2. Set or check maximum suction restriction of fuel supply line.
 - 3. Set manifold pressure.
 - 4. Reset rear throttle stop screw.

- C. Throttle leakage
 - 1. Set forward throttle stop screw.
- D. Governor
 - 1. Set maximum governed rpm.
 - 2. Set idle rpm.

FUEL PUMP TEST STAND -- The test stand (see Figure 8) drive shaft is driven by an electric motor and variable speed drive. The electric motor reverses direction so right and left hand pumps can be calibrated. The tachometer is coupled to the drive unit and registers fuel pump rpm.

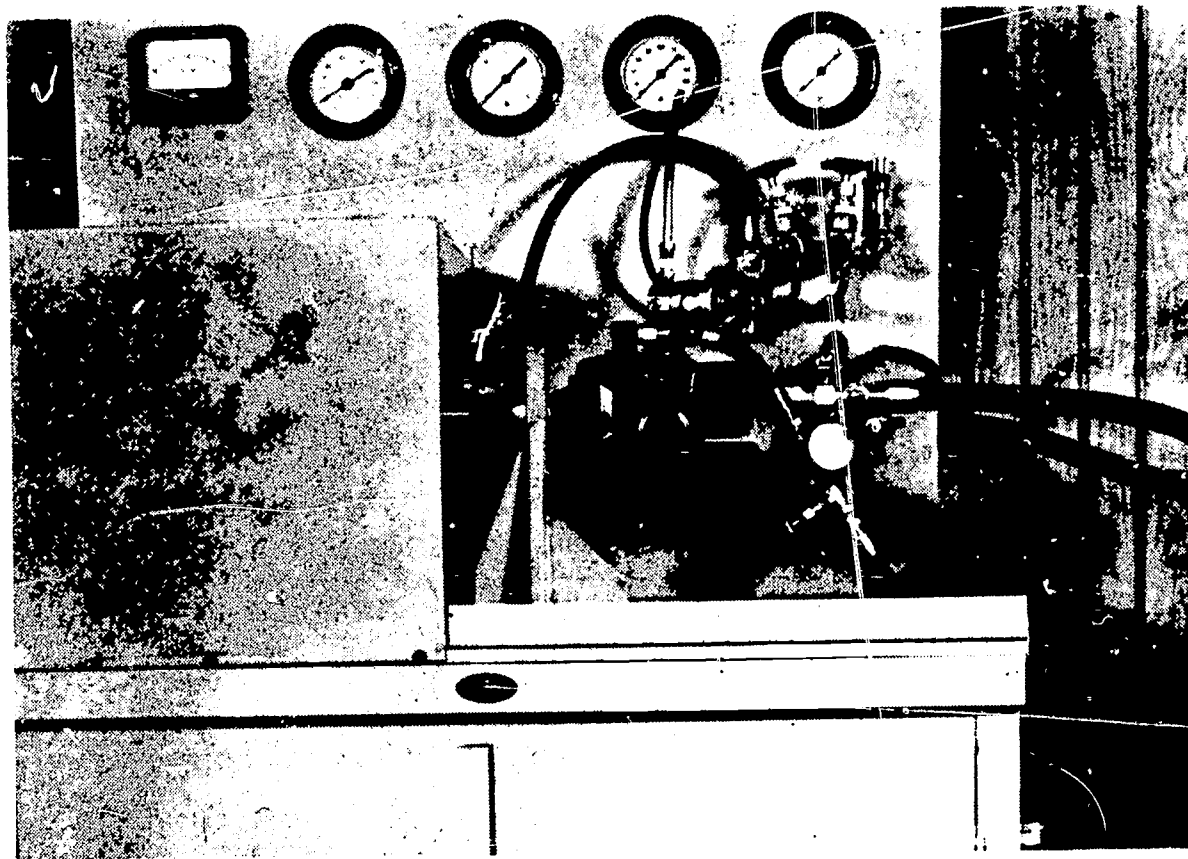

Fig. 8 Fuel pump test stand.

Test oil temperature is registered on the instrument panel temperature gauge. It can be regulated by heaters. The suction line valve simulates maximum suction line restriction for measurement on the vacuum gauge. Two pressure gauges register gear pump pressure and fuel manifold pressure.

The orifice block contains two manifold orifices and two valves, one for idle fuel pressure and one for high speed fuel pressures. The valves are used in wide open position to direct fuel through the desired orifice. The valve at the end of the orifice block checks throttle leakage.

The sight glass shows the presence of air being delivered to the fuel manifold.

The pump body by-pass line and valve passes fuel to the drain board. This valve pressurizes the pump body to check seals and gaskets.

To reduce starting loads on the electric drive motor, reduce pump speed to 500 rpm before stopping test stand.

INSTALLING PUMP ON STAND -- The following procedure outlines the proper method of installing the PT pump to the test stand:

1. Install proper drive coupling to test stand drive shaft.
2. Mount fuel pump on mounting bracket (flange-type pump to ring, rear mount pump to back bracket), adjust test stand drive coupling for 1/16 inch space between coupling halves.
3. Connect gear pump pressure line to gear pump.
4. Squirt clean lubricating oil in gear pump inlet hole and install suction line fitting. Oil pre-lubricates and primes the gear pump.
5. Connect gear pump suction line to inlet fitting adapter.
6. Install fuel pump drain base, gauge and valve to pump drain fitting.
7. Connect copper line from orifice block to fuel pump shut-off valve.

TESTING THE PUMP -- After making sure the pump has been properly installed, proceed with the following steps:

1. Open pump shut-down valve, manifold orifice valve, suction line valve and fuel pump by-pass

valve. **OPEN THROTTLE**, run pump at 500 rpm until manifold pressure gauge shows pressure. If gear pump does not pick up, check for air leak or closed valve in suction line.

If pump is rebuilt or has been opened, run at 1500 rpm for five minutes to flush pump and allow bearings to seat.

NOTE: Before calibration, check graduate or orifice block sight gauge for air. If present, correct air leak before continuing test. Check fuel pump for leaks by operating valve on pump drain line to maintain 15 psi. Check all seals and gaskets for leaks.

2. Continue to run the pump at 1500 rpm.

PRELIMINARY CHECKS -- Prior to actually calibrating the pump there are some required steps to be done depending on the type of pump. On the variable speed governor type, the forward throttle stop screw must be adjusted to completely shut off the fuel delivery. Check the maintenance manual for other deviations from the procedure outlined below.

CALIBRATING --

1. Test oil temperature should be 80 F to 100 F.
2. Set approximate governor speed:
 - a. Open valve to manifold orifice. Close orifice valves.
 - b. Move throttle control lever to full-fuel position.
 - c. Increase pump speed until manifold pressure gauge registers highest pressure. This should be rated rpm or higher. The approximate governor speed check assures that dump holes are not open during calibration at 100 rpm less than rated speed.

If fuel manifold pressure gauge registers the highest pressure at less than rated governor speed, add shims to the governor hi-speed spring. On variable speed governor pump adjust maximum screw.

3. Set pressure regulator spring load: set pressure regulator spring load with the fuel regulator set gauge.

FUEL MANIFOLD PRESSURE --

1. To set maximum open throttle position:
 - a. Open manifold orifice valve.
 - b. Set throttle in forward or open position.
 - c. Set fuel pump speed at 100 rpm less than rated speed.
 - d. Turn rear throttle stop screw in until manifold pressure begins to decrease; back screw out until manifold pressure raises to highest point.
2. To set maximum suction restriction:
 - a. Open manifold orifice valve.
 - b. Set throttle in forward or open position.
 - c. Set fuel pump speed at 100 rpm less than rated speed.
 - d. Adjust valve in pump suction line to 8 inches mercury.
3. To set fuel manifold pressure:
 - a. Open manifold orifice valve.
 - b. Set throttle in forward or open position.
 - c. Set fuel pump speed at 100 rpm less than rated speed.
 - d. Set manifold pressure 4-6 psi more than the pressure listed in calibration data. This pressure will be reduced in Step 4.

Add or remove shims from under fuel adjusting plunger. Remove shims to raise pressure, add shims to lower pressure.

If pressure regulator assembly is removed to change pressure, tighten cap to 20/25 foot-pounds and recheck pressure setting.

4. Set Maximum Throttle Restriction:
 - a. Open manifold orifice valve.
 - b. Set throttle in forward or open position.
 - c. Set fuel pump speed at 100 rpm less than rated speed.
 - d. Turn rear throttle stop in until fuel manifold pressure decreases 5 psi.

THROTTLE LEAKAGE -- Set the throttle leakage as follows:

1. Close all manifold orifice valves and open valve at end of orifice block.
2. Run hose from valve at end of orifice block into 500 cc glass graduate.

3. Move throttle to idle position and raise pump speed 100 rpm below rated governed speed.
4. Turn forward throttle stop screw "in" until fuel pump delivers amount of fuel indicated under "Throttle Leakage" in calibration data.
5. Lock screw at this setting. NOTE: This setting is not required on variable speed or torque fuel pumps.

GOVERNOR -- Set the governor speed as follows:

1. Close glass graduate valve and open manifold orifice valve; move throttle to full-fuel position.
2. Raise fuel pump speed until maximum fuel manifold pressure is reached. Increase fuel pump speed until fuel manifold pressure drops to pressure valve under "Governed" in calibration data. If speed is low, add shims between high-speed governor spring and spring retainer; remove shims if speed is too high.
3. Each .001 inch shim thickness changes speed approximately 4 rpm.
4. Each time the governor spring pack is removed the fuel pump must be operated until free of air to maintain indicated speed accuracy, which is affected by air in the fuel pump body around the governor weights.
5. On fuel pumps with speed adjusting screws on the spring pack housing, the bottom screw is for maximum governed speed settings.

IDLE PRESSURE -- Set the idle pressure as follows:

1. Open the idle orifice valve and close other orifice valves.
2. Set throttle in idle position and run fuel pump at 500 rpm.
3. Adjust manifold pressure to value listed in fuel pump calibration data. To raise pressure turn idle adjusting screw in, to lower pressure back screw out. Idle screw is accessible through pipe plug in rear of automotive spring pack cover.
4. To change idle speed on fuel pumps with road speed governor, add or remove shims from under idle spring. NOTE: Set idle speed after throttle screws are adjusted.

SECTION C -- CALIBRATING THE FUEL INJECTORS

INJECTOR TEST STAND -- Figure 9 shows a typical test stand for calibrating and testing PT fuel injectors. This test equipment will flow-test the complete injector assembly by measuring fuel delivery. The injector is actuated under controlled conditions which are very close to actual operating conditions. The test stand counts injection strokes, supplying fuel at a specified pressure, thereby measuring the delivery in a glass graduate.

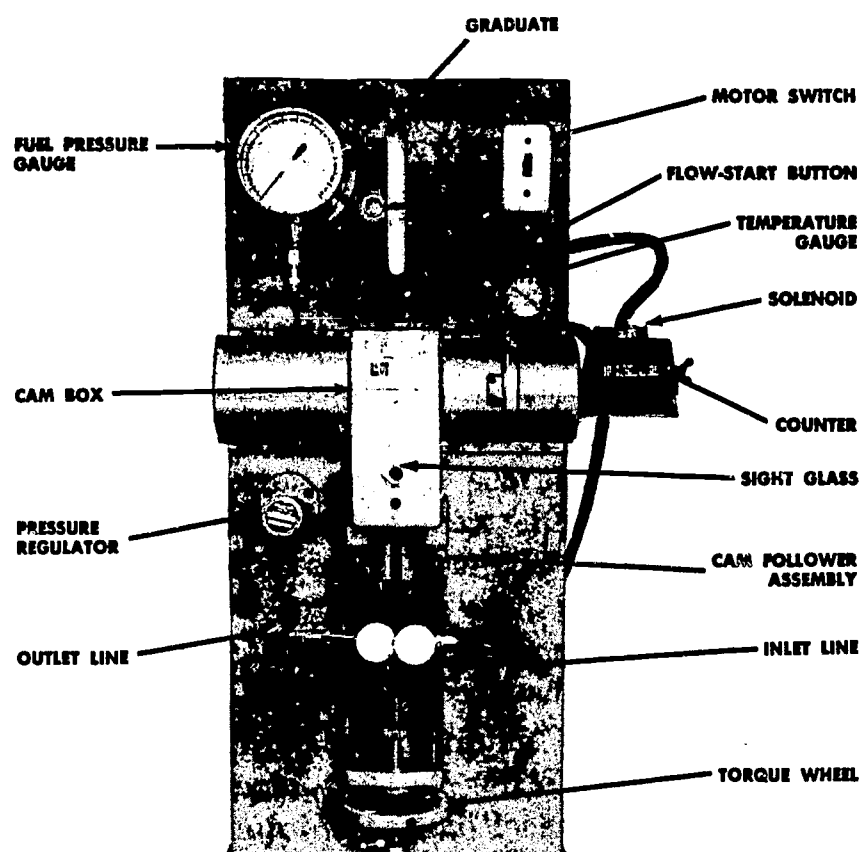

Fig. 9 Injector test stand.

TEST STAND INSTALLATION -- The test stand must be situated near hot and cold water connections. Water temperature, controlled by a mixing valve, is used to maintain test oil at an 80 F to 100 F temperature range.

TEST STAND PREPARATION -- The following steps must be performed prior to calibrating the injectors:

1. Fill the test stand 2/3 full of test oil and maintain this level or higher during test. Test oil capacity is approximately five gallons. Check your maintenance manual for proper oil grade.
2. Fill the cambox, (see Figure 9), with three inches of SAE 30 non-detergent lubricating oil. Refill when oil level drops to sight glass.
3. Check position of counter. Set white wheels to zero by turning reset clockwise.

CLARIFYING INJECTOR NOMENCLATURE -- Before we go into the testing of injectors, let's clarify some injector terminology:

1. **PT INJECTORS** indicate that PT injectors are different than those used with disc and other fuel systems.
2. **MATCHED PT INJECTORS** have been delivery checked on ST-590 Injector Test Stand and placed in engine sets; these do not have adjustable orifice plugs in the inlet drilling.
3. **ADJUSTABLE DELIVERY PT INJECTORS** have an adjustable orifice plug in the inlet drilling. These injectors can have delivery changed by installing different size orifice plugs.
4. **ADJUSTABLE ORIFICE PLUG** is used in inlet drillings of adjustable delivery injectors to adjust fuel delivery.
5. **METERING ORIFICE** is a drilled orifice in the cup end of the injector body through which fuel is metered into the injector cup.
6. **DRAIN ORIFICE** is a drilled orifice in the cup end of the injector in the drain drilling.

IDENTIFICATION OF INJECTORS -- Various types of injectors are available for use in Cummins engines. Figure 10 shows how these are identified as orifice size, cup spray hole size, and cup spray angle.

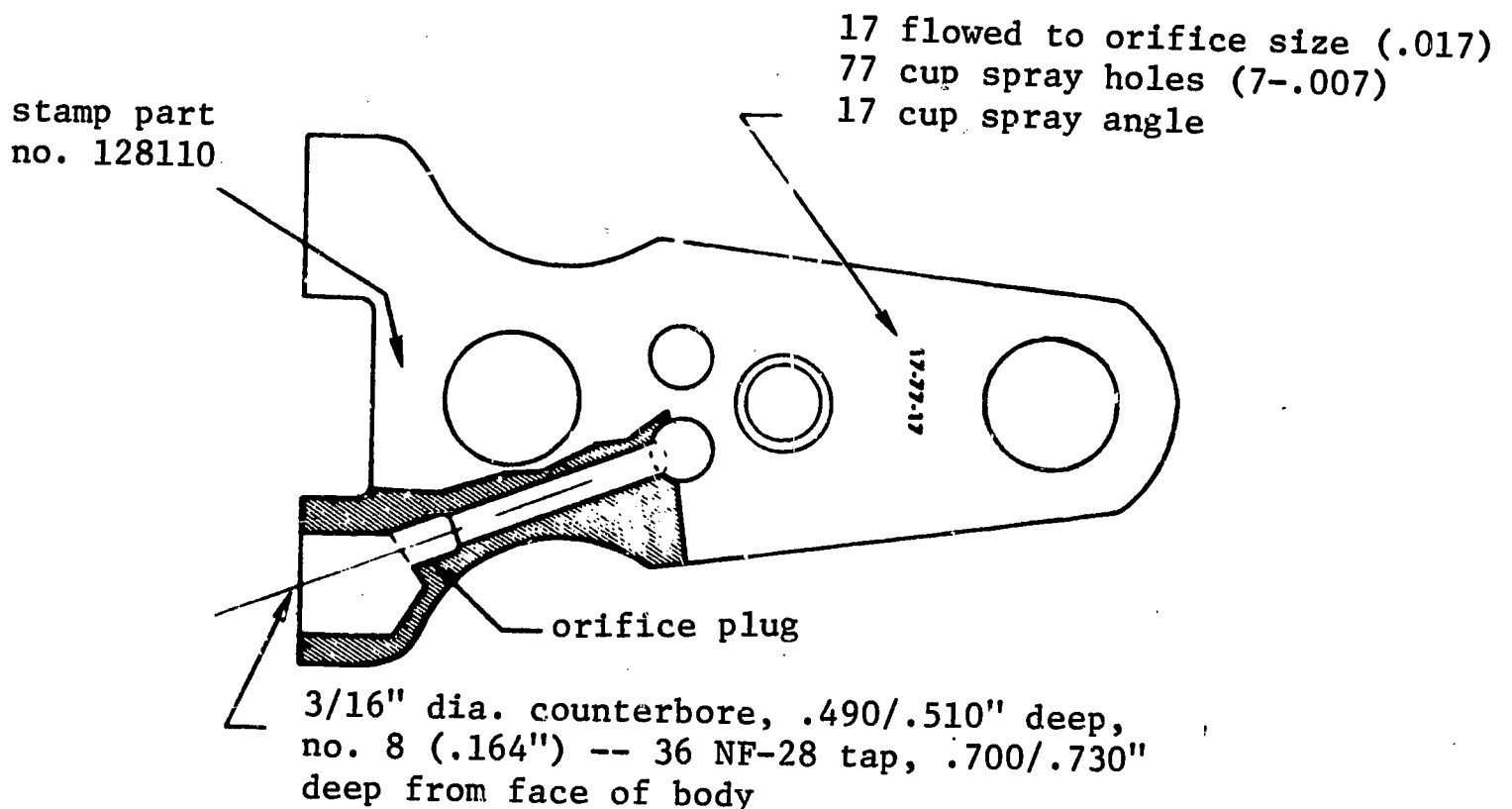

Fig. 10 Stamping on injector body.

FLOW TESTING ADJUSTABLE DELIVERY INJECTORS -- Various adapters and push rod extensions are available to permit the testing of different injectors. Consult the manufacturer's specifications for this information. Below is a step-by-step procedure recommended for flow testing the injectors on the test stand.

First, turn the index wheel to align the index mark with the arrow on cover. This assures that injector will clamp at bottom of plunger stroke.

Next, install the proper adapter over assembled injector with the push rod extension as required. **NOTE:** Refer to Figure 9 when studying this procedure.

Next, turn the injector plunger so the size mark on the spring retainer faces the operator and away from the test stand.

Next, place the injector cup in the seat of the clamping screw head with the adapter ears engaging the hanger rods. NOTE: When testing the "L" injector, use one hanger rod spring on each rod above the adapter. In testing J, H, and NH injectors, use both springs on each rod above the adapter.

Then tighten the injector clamping head wheel until torque permits the hand wheel to rotate alone. Tighten the thumb screw to lock the wheel.

Next, install the fuel line fittings into the injector inlet and outlet ports. Start the motor and adjust the fuel pressure to the master injector specified pressure. NOTE: Fuel temperature should be 80 F to 100 F. To accomplish this, run the test stand and adjust the water flow so that the fuel temperature can be maintained at the proper value.

When there is an indication of air being expelled from the transparent line, press the fuel flow start button. This will engage the counter and will divert injector fuel output to the calibrated vial (small liquid holder -- graduate).

After the injector runs the number of preset strokes, the counter will disengage and the injector fuel output will be directed to the fuel tank. At this time, the tester must be turned off. With the tester off, reset the counter by turning the wing nut so that all white wheels are at zero.

Check the maintenance manual for the fuel output from the graduate and check the flow against the cc flow.

After checking the flow, and it is determined that the flow is out of specification, change the orifice plug on the inlet passage. Install plugs and tighten to 3 to 4 inch-pounds. Change to a larger or smaller orifice as required. Check pressure before testing the second time.

As a final step, rotate the vial holder to position the second vial for the next test. Repeat the test as required, using selected orifice plugs until the flow is brought to within specifications. CAUTION: Due to its small size the adjustable orifice plug is difficult to identify. DO NOT MIX PLUGS.

FLOW TESTING MATCHED INJECTORS -- Injectors without removable orifice plugs at the inlet connection are flow tested in the same manner as adjustable delivery injectors, by using a corresponding master injector, see the maintenance manual.

After each non-adjustable delivery injector is flow tested, indicate the delivery flow on the body. If the delivery runs higher than the master, fuel pump manifold pressure must be lowered to obtain the proper fuel rate. A lower delivery than the master injector may call for raising fuel manifold pressure. Changing fuel manifold pressure under these conditions is necessary since there is no way to change injector delivery.

One cubic centimeter variation in fuel delivery on the injector test stand affects fuel manifold pressure approximately 5 psi.

This has been a brief discussion of the Cummins fuel pump and injectors. Space will not permit a complete tear-down of either of the two components at this time. More will be presented on this fuel system and its components later in the course.

II -- RADIATOR SHUTTER SYSTEM

SECTION A -- UNDERSTANDING THE SHUTTER SYSTEM

A large number of diesel powered vehicles, especially those operated in extreme temperature localities are equipped with radiator shutter systems. This equipment supplements the thermostat's function by stopping air from entering the radiator. Some advantages over those applications not having the shutter system are:

1. More control over engine temperature.
2. A quicker response to maintaining the normal operating temperature.
3. Engine can be brought up to temperature in extreme cold weather.

The shutter system consists of a shutter, a cylinder a control valve and air filter, and piping to the air tank or reservoir; (See Figure 11).

OPERATION -- The shutter is mounted directly in front of the radiator, and the temperature sensitive control valve is situated in the engine water outlet manifold. Compressed air from the vehicle air system (to be discussed later) is used to actuate the cylinder. The air is filtered before entering the control valve to remove any oil or sludge that might be carried through the lines from the reservoir.

When the engine is below operating temperature, the control valve directs air to the cylinder to close the shutter. Engine temperature then rises quickly, because air cannot be drawn through the radiator. When engine water temperature reaches a certain high, the control valve is opened, and air is allowed to escape from the air cylinder. As air escapes from the cylinder, the spring force overcomes the cylinder pressure and the shutters

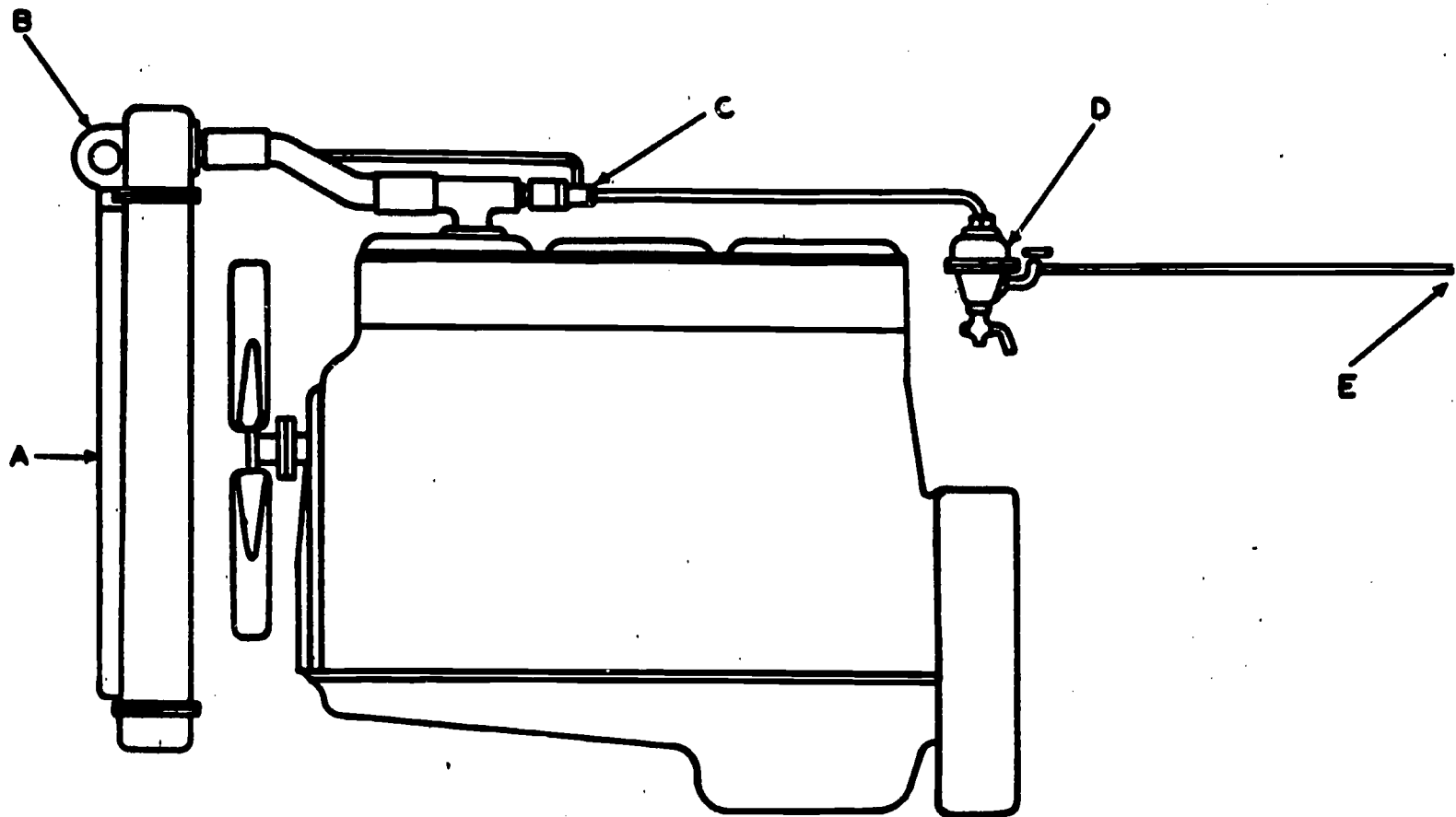

A—Shutter Vanes
B—Air Cylinder

C—Control Valve
D—Air Filter

E—Air Reservoir

Fig. 11 Automatic radiator shutter diagram.

open. The set temperature is maintained by the shutter remaining open and closed for varying periods of time, depending upon engine load and air temperature. This oscillation of the shutter between fully-open and fully-closed is accompanied by an inherent lag of approximately 7 degrees F in the control valve to prevent excessive cycling.

For efficient operation, the shutter system should be serviced in accordance with the regular scheduled maintenance.

SECTION B -- THE SHUTTER

Figure 12 shows the shutter linkage and components that are necessary for it to operate. The shutter is mounted directly on the radiator frame for efficient operation. The blades pivot in oil impregnated bushings and are tied together by an operating bar, which is spring loaded to hold the blades open. This bar may be actuated by the shutter cylinder through one of several linkage arrangements, all of which close the shutter when the cylinder is energized.

- A—Shutter
- B—Actuating Bar
- C—Spring
- D—Bushing
- E—Vane
- F—Mounting Bolt
- G—Shutter Cylinder
- H—Pull Rod
- J—Radiator

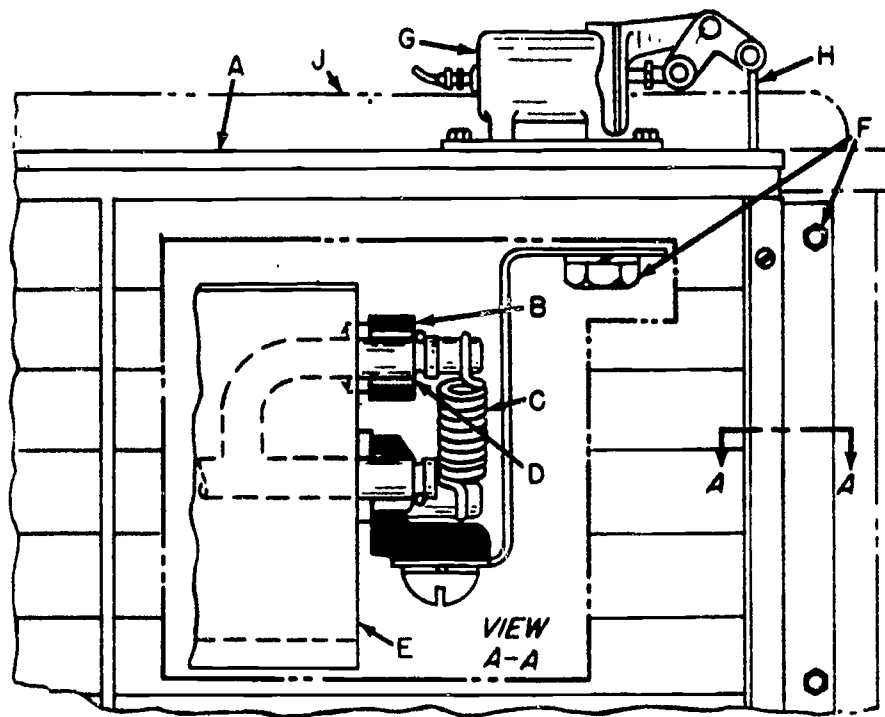

Fig. 12 Shutter linkage.

Dirt accumulations on the shutter linkage may cause binding and thus result in faulty engine temperature control. For this reason, it is advisable to wash the linkage with water, as often as necessary to keep it clean.

Shutter linkage does not require frequent lubrication; however, when oiling is necessary, a light oil should be applied sparingly to each movable joint. Excessive lubricant will only increase the rate of dirt accumulation.

SHUTTER ADJUSTMENT -- The shutter linkage can be adjusted as follows:

Adjust shutter linkage with shutter open so that rubber edges of shutter blades will be compressed slightly when the shutter is closed by cylinder actuation.

REMOVAL AND INSTALLATION -- The shutter is removed without disconnecting the cylinder air line in the following manner:

Detach linkage at shutter. Remove cylinder mounting capscrews if cylinder is not mounted remotely from shutter. Remove shutter mounting bolts and raise shutter from vehicle.

Installation is the reverse of removal.

SHUTTER OVERHAUL -- Overhaul of the shutter is by replacement of parts. A screwdriver is the only tool necessary for disassembly of the frame and the method of part replacement is self-evident.

SECTION C -- SHUTTER CONTROL CYLINDER

In Figure 12(g) we can see how the control cylinder operates the shutter through linkage. Figure 13 shows the internal parts of this control.

The cylinder is a single piston type that mounts on the shutter frame or a bracket and is used with various linkage arrangements, depending on the

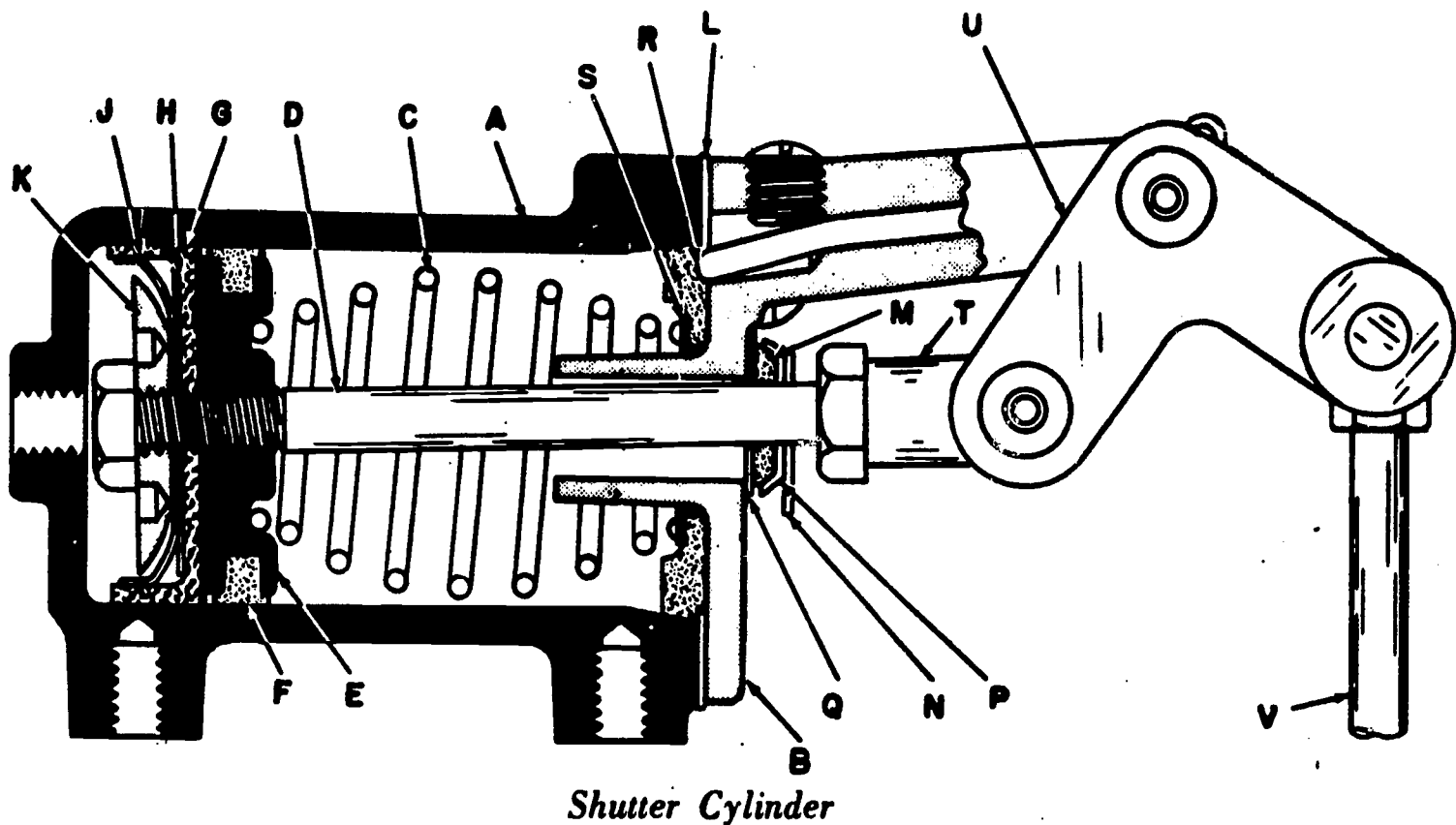

A—CYLINDER
 B—HEAD, Cylinder
 C—SPRING
 D—ROD, Piston
 E—HEAD, Piston
 F—FELT, Oiler

G—CUP, Piston
 H—WASHER, Piston Cup
 J—EXPANDER, Piston Cup
 K—FOLLOWER, Piston Cup
 L—GASKET, Cylinder Head
 M—FELT, Breather
 N—RETAINER, Breather Felt

P—CAP, Dust
 Q—WASHER
 R—FELT
 S—RING, Retaining
 T—YOKE
 U—BELLCRANK
 V—ROD, PULL, Shutter

Fig. 13 Shutter cylinder.

installation. Cylinders having a lever arrangement use a support arm integral with the head as shown in Figure 13.

OVERHAUL -- To insure trouble-free operation, the cylinder should be overhauled periodically as follows: Remove hard retaining screws and pull piston and rod assembly from cylinder. Secure yoke in a soft jawed vise. Remove piston jam nut and cup follower, then disassemble piston. A wrench for the cup follower can be made from a standard 9/16" six-point socket by grinding the edge to obtain two suitable prongs. Remove breather felt retainer screw and disassemble breather.

Discard felts, piston cup and expander, wash parts in solvent and dry with compressed air. Inspect cylinder bore for smoothness. Replace parts as necessary to remove any sloppiness in linkage. Check all threads.

Assembly is essentially the reverse of disassembly. Do not overtighten piston jam nut. Prior to installing piston, saturate felts with SAE 10 engine oil, and coat cylinder bore and piston parts with light non-hardening grease. Be sure piston cup is not turned back or torn during installation.

TEST -- With cylinder removed from shutter frame, connect 90 psi air supply and submerge unit in water. Piston cup leakage is indicated if air escapes from piston rod opening in head.

SECTION D -- SHUTTER CONTROL VALVE

The shutter control valve regulates the flow of air to or from the shutter cylinder, to close or open the shutter, in response to engine temperature changes. When installed, the bellows assembly bulb is immersed in engine outlet coolant, and expansion or contraction of the bellows provides the movement for valve actuation; (See Figure 14).

When the engine temperature is below the set temperature, the needle is against the lower seat, allowing air to flow from the inlet connection in the cap to the outlet connection in the body side.

When the engine reaches control valve operating temperature, bellows expansion lifts the push pin and needle to close the inlet and open the exhaust circuit from the outlet to the atmosphere. The operating temperature is adjusted by changing the bellows spring-loading with the adjusting wheel.

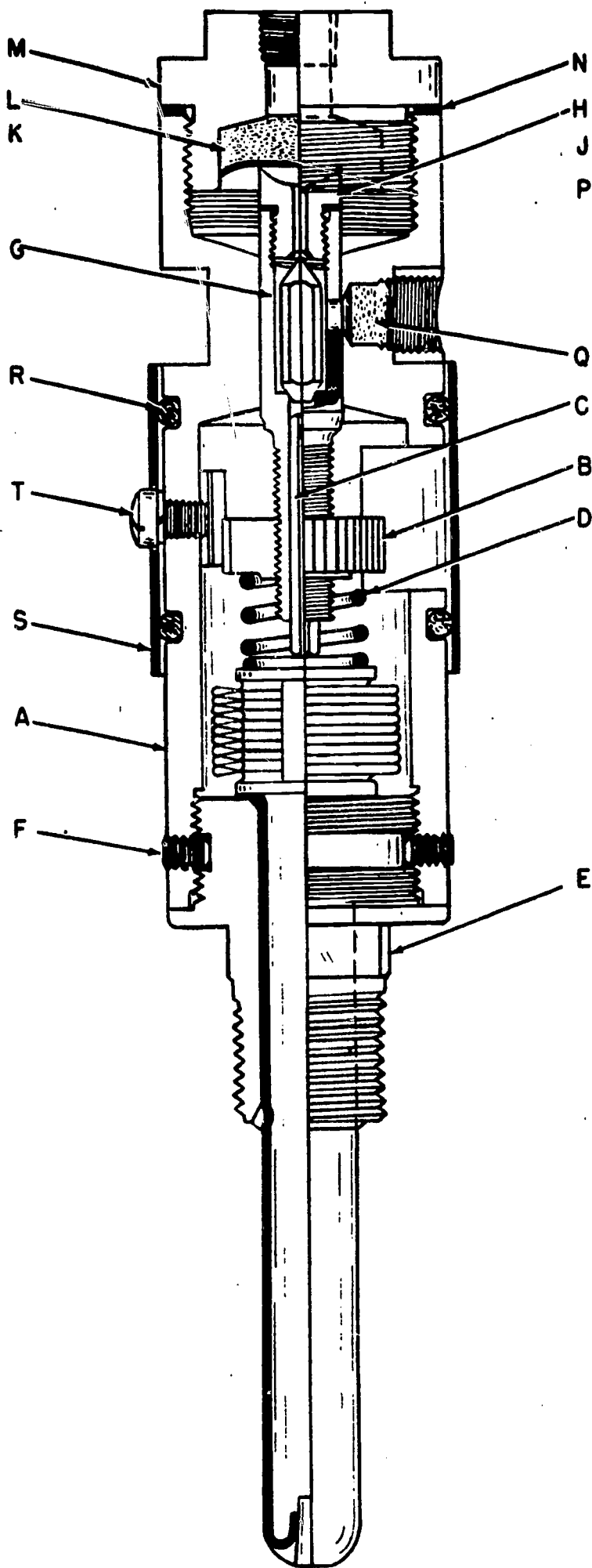

- A—BODY
- B—WHEEL, Adjusting
- C—PIN
- D—SPRING
- E—BASE
- F—SCREW, Set
- G—NEEDLE
- H—CAP, Needle Seat
- J—GASKET, Needle Seat Cap
- K—SCREEN
- L—FELT, Cap
- M—CAP, End
- N—GASKET, Cap
- P—SCREENS
- Q—FELT
- R—RING, Seal
- S—JACKET
- T—SCREW, Lock

Fig. 14 Sectional view of control valve.

CONTROL VALVE SETTING -- The control valve should be set so that the shutter opening temperature will correspond to the thermostat opening temperature. This setting will vary depending on the locality. At Reserve Mining, this control is set 5 degrees F above the thermostat. Removal of the shutter mechanism is not necessary to make this adjustment. The procedure is as follows: Insert an accurate zero to 212 F thermometer in the radiator so that the bulb is immersed in coolant.

This will allow more accurate readings than are possible with the temperature gauge on the instrument panel. This temperature should correspond to the correct seasonal figure. Take a second reading when shutter closes. This reading is normally 5 to 7 degrees F below the opening temperature. **NOTE:** If the lag is excessive, clean or replace valve.

To adjust the valve, remove jacket lock screw, slip jacket down to expose adjusting wheel and turn wheel to the left to raise, or to right to lower, shutter opening temperature. Five clicks of the wheel will alter the shutter opening temperature approximately 2 degrees F.

SECTION E -- AIR FILTERS

Figure 15 shows an exploded view of the air filter shown as part of the shutter mechanism in Figure 11 (d).

The felt element is kept saturated with shutter fluid by a wick which transfers fluid from the fluid reservoir. Air from the air reservoir enters the sump through the side connection. It then passes through the element and is directed to the control valve through the cover connection above the element. Suspended particles, separated from the air by the filtering element, fall to the bottom of the sump, where they are readily drained off through the drain cock.

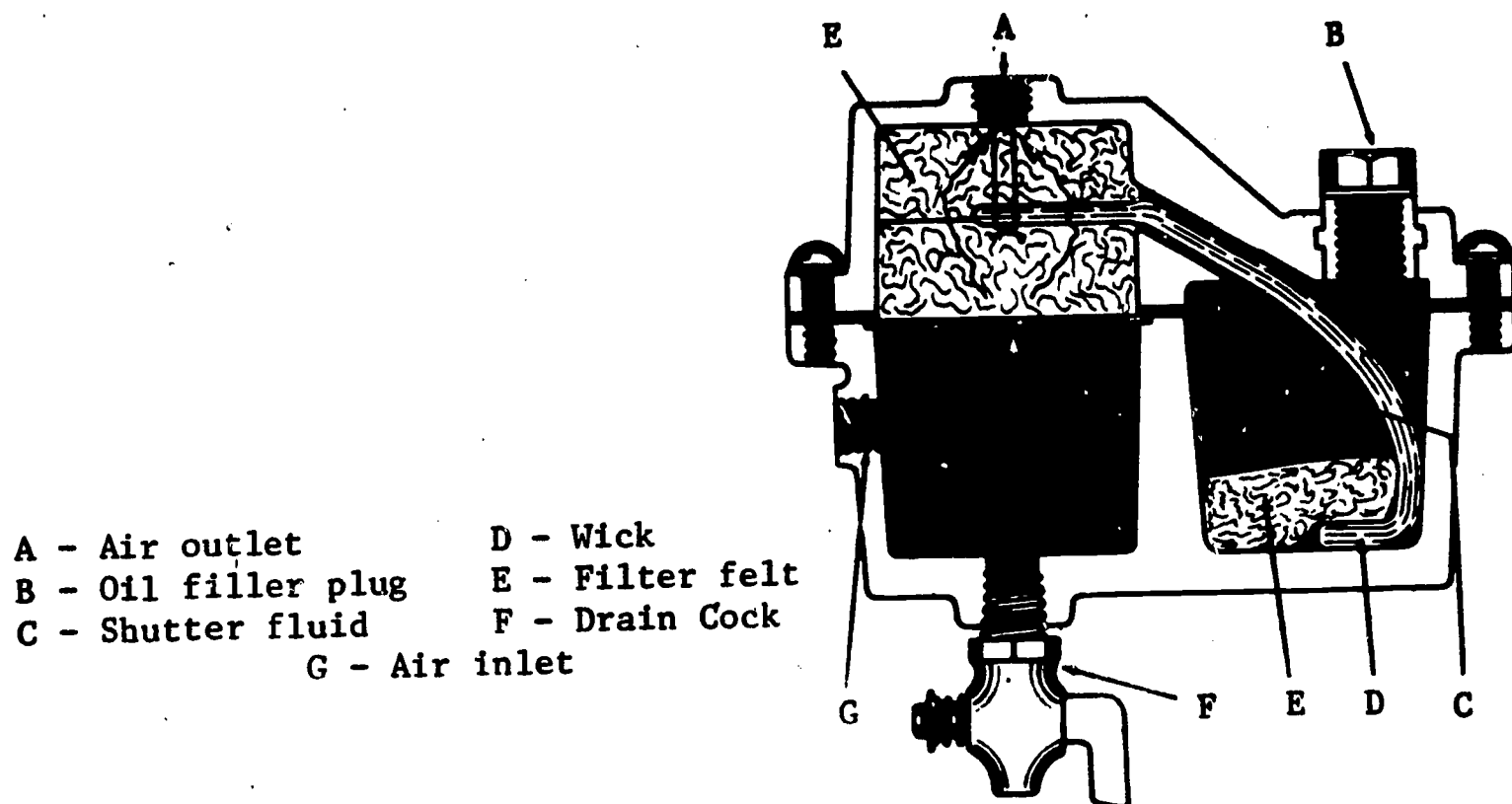

Fig. 15 Air filter.

By closing the valve at the filter inlet and opening the drain cock, the shutter cylinder can be dumped so that the shutters will remain open. This provision makes it possible to operate the vehicle, in case of control valve failure, without danger of overheating.

Accumulations should be drained under pressure from the sump daily, and shutter fluid should be added to the filter reservoir as required.

The filter should be disassembled and cleaned yearly. At this time the old felts and wick should be replaced.

DIDACTOR PLATES FOR AM 1-13D

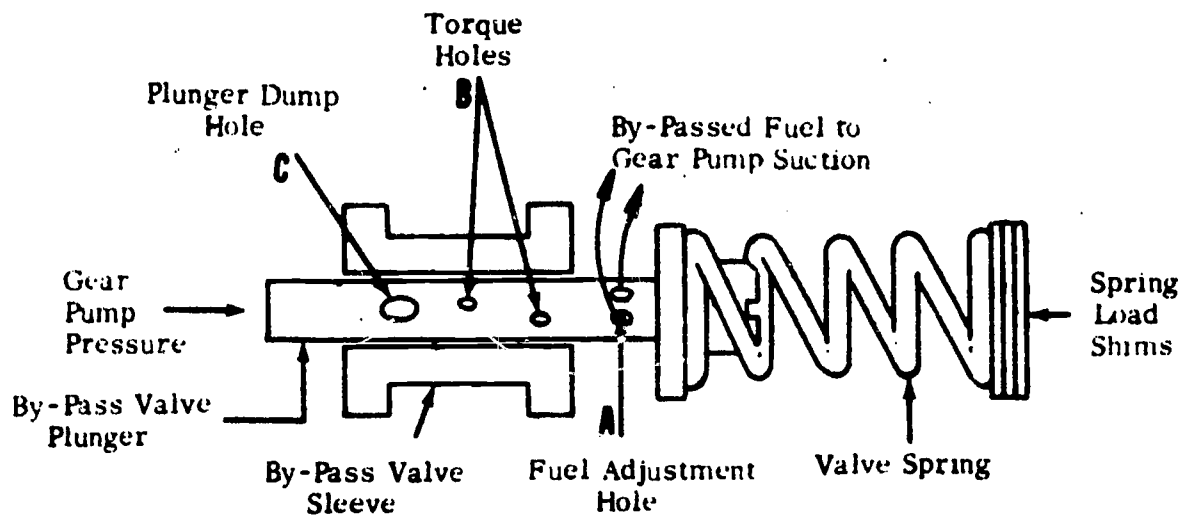

Plate I Pressure regulator by-pass valve.

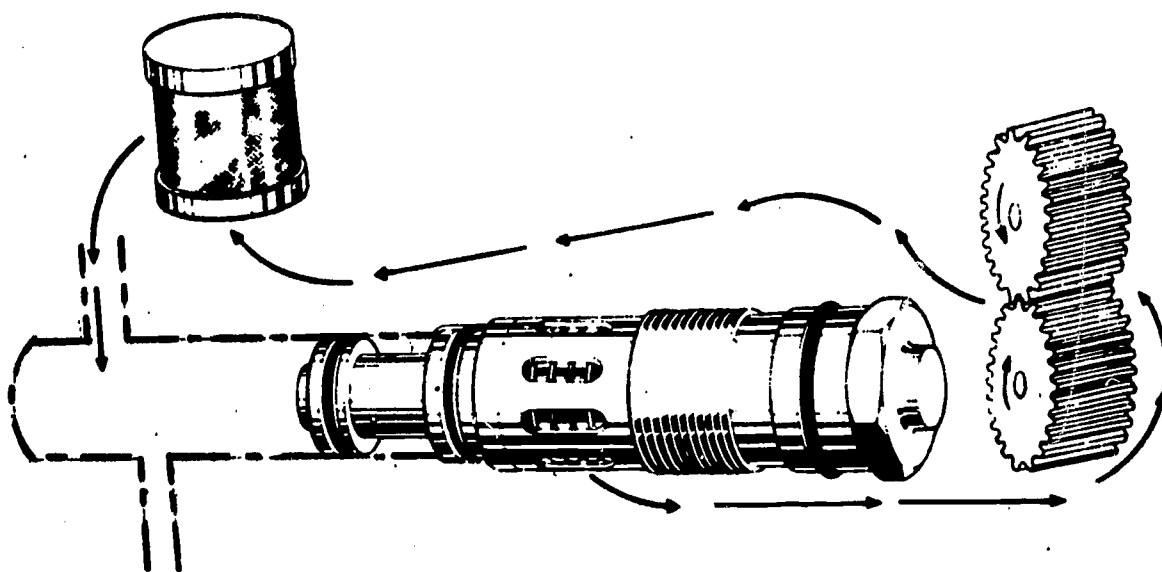

Plate II Fuel flow under gear pump pressure.

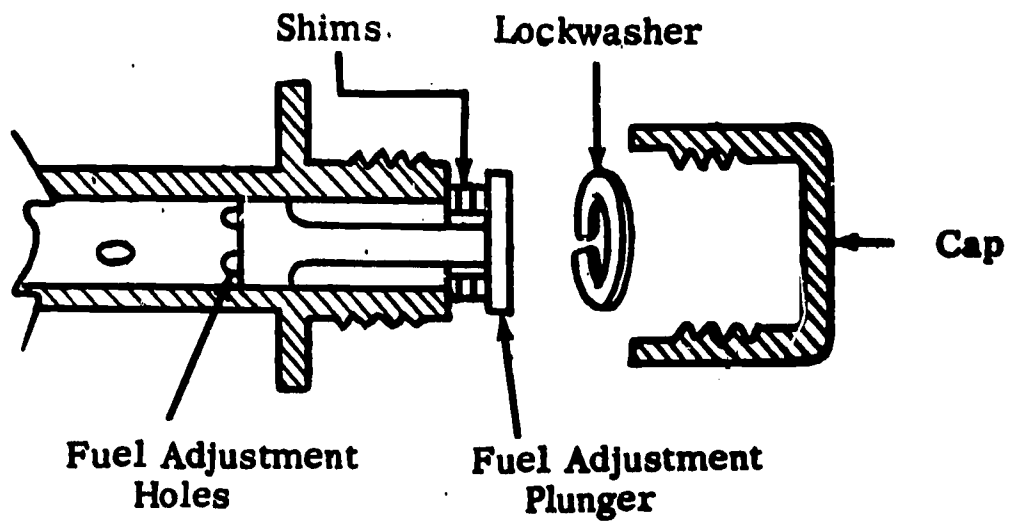

Plate III Fuel adjustment plunger.

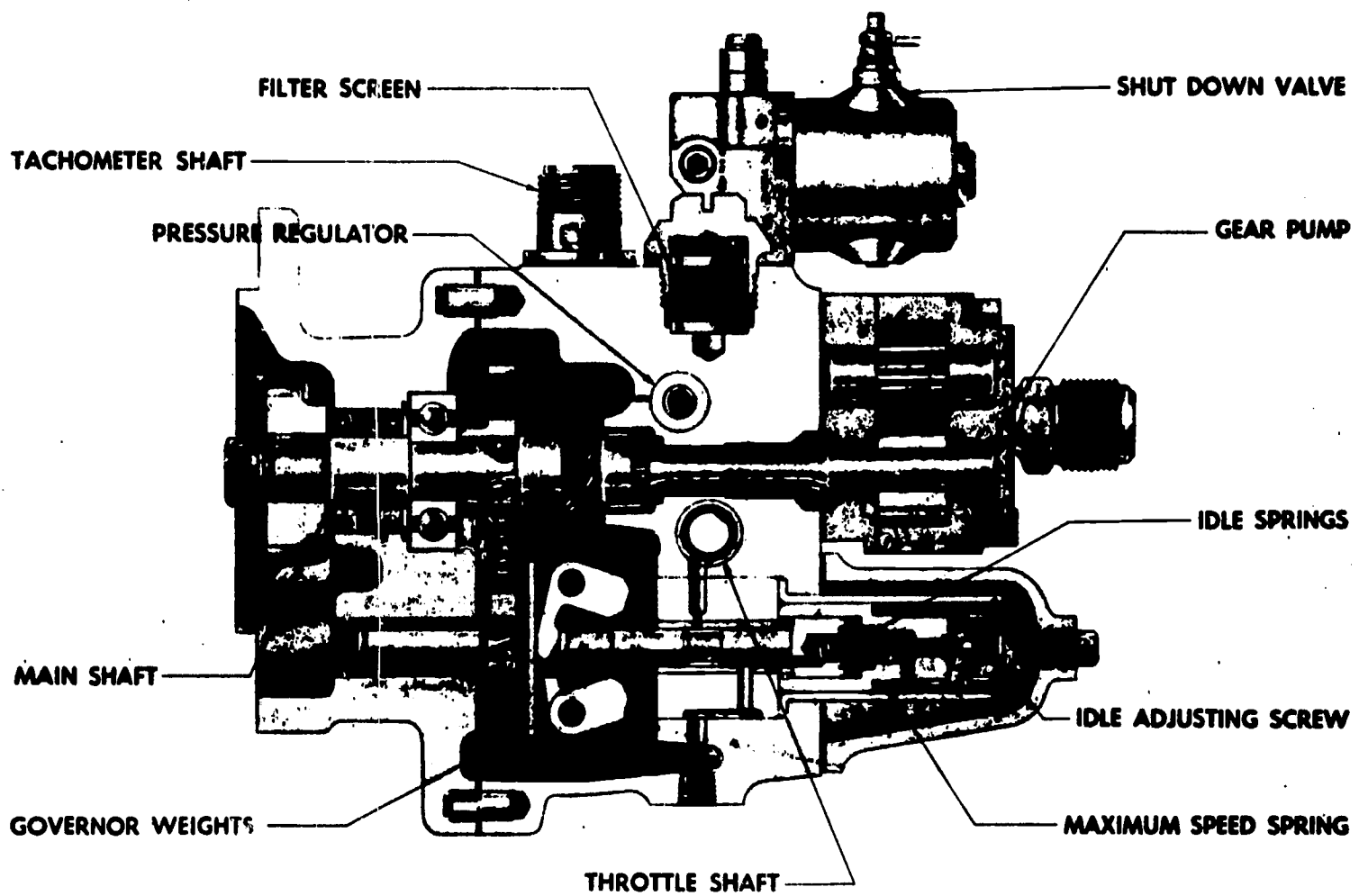
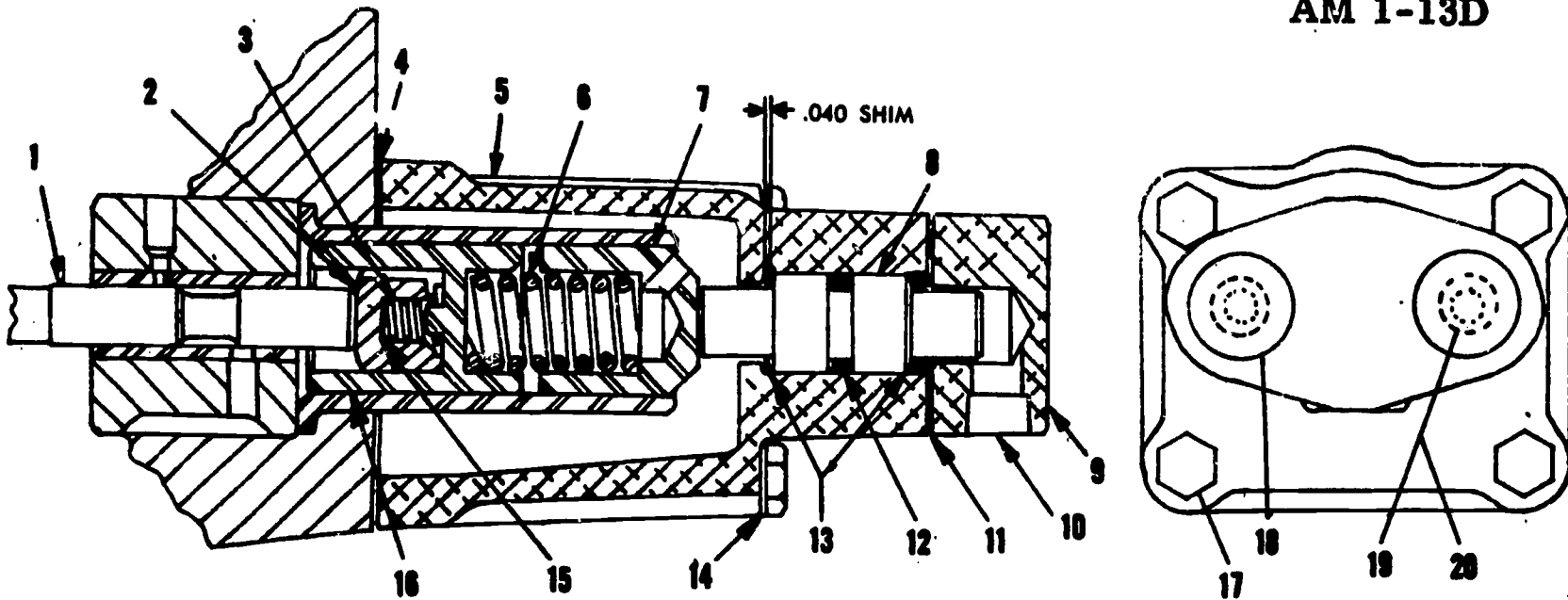

Plate IV Idling and high speed mechanical governor.



- | | |
|--------------------------------|-----------------------|
| 1. Automotive Gov. Plunger (1) | 11. Gasket |
| 2. Plunger | 12. "O" Ring |
| 3. Idle Spring | 13. Shims (as reg'd.) |
| 4. Gasket | 14. Lockwasher |
| 5. Housing | 15. Shims (as reg'd.) |
| 6. Spring | 16. Plunger |
| 7. Plunger | 17. Capscrew |
| 8. Air Piston | 18. Seal Cover |
| 9. Cover | 19. Lockwasher |
| 10. 1/8 Inch N.P.T.F. Hole | 20. Capscrew |

Plate V Governor spring pack assembly.

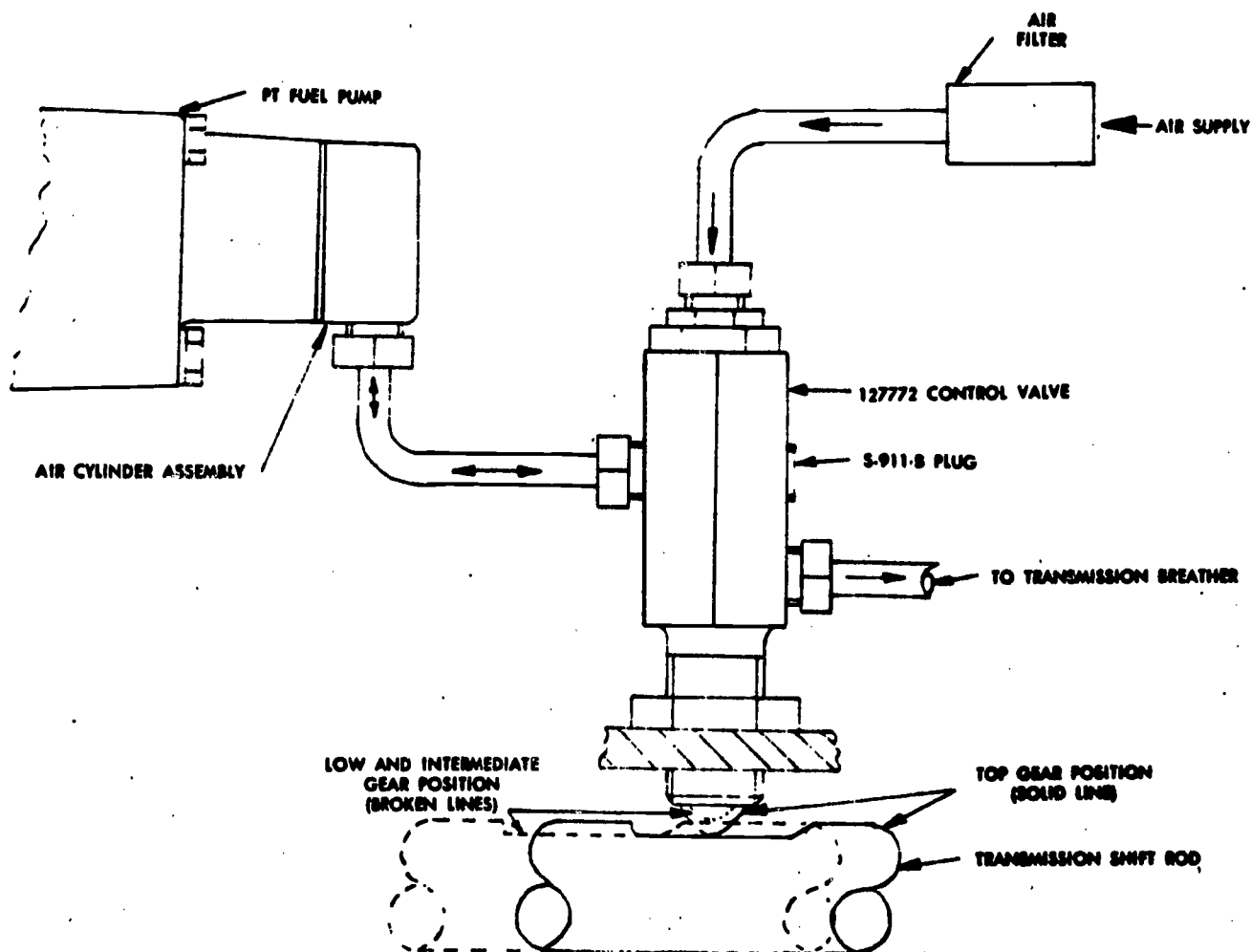

Plate VI Piping with single valve on transmission for road speed governor.

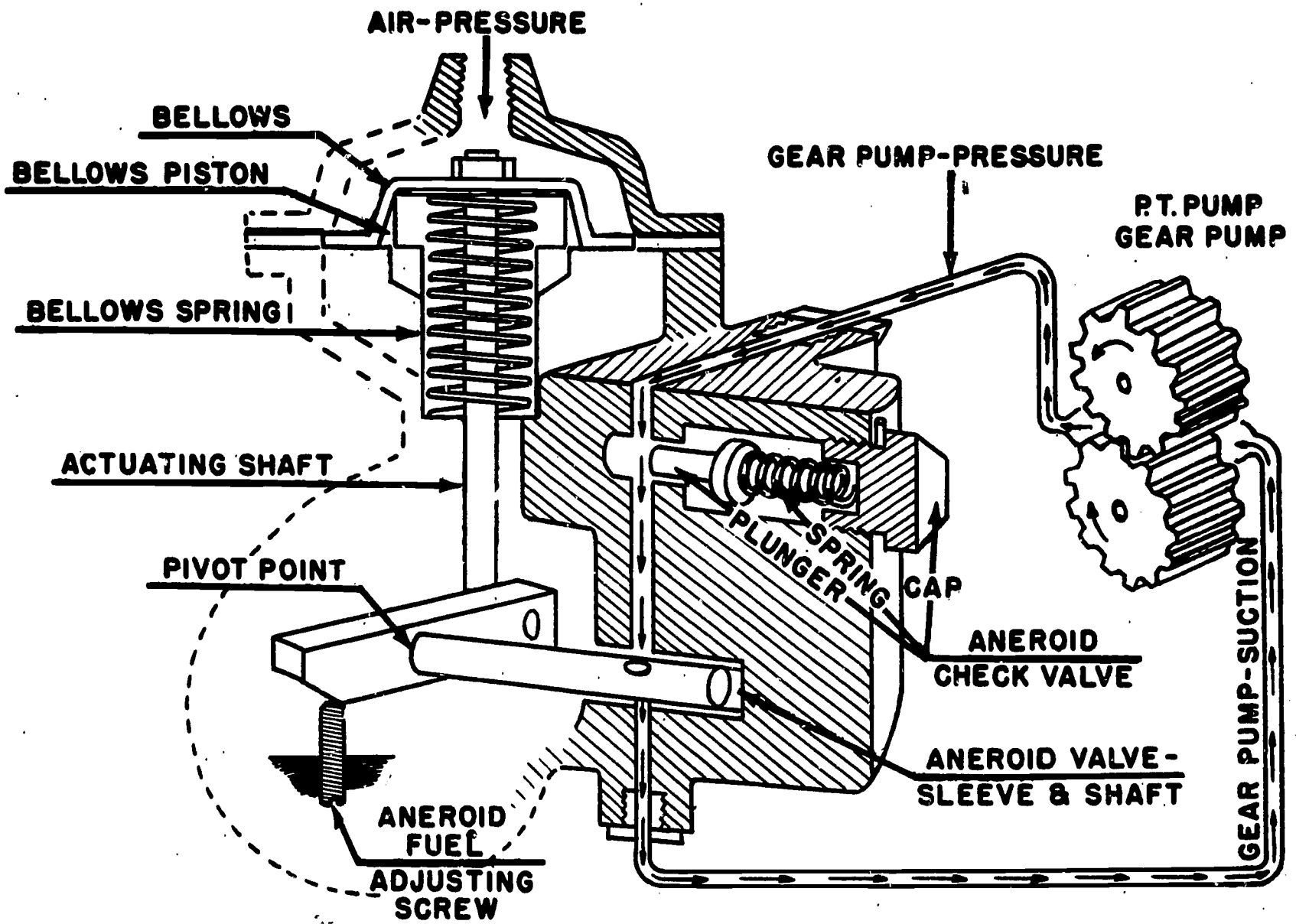

Plate VII Aneroid fuel control.

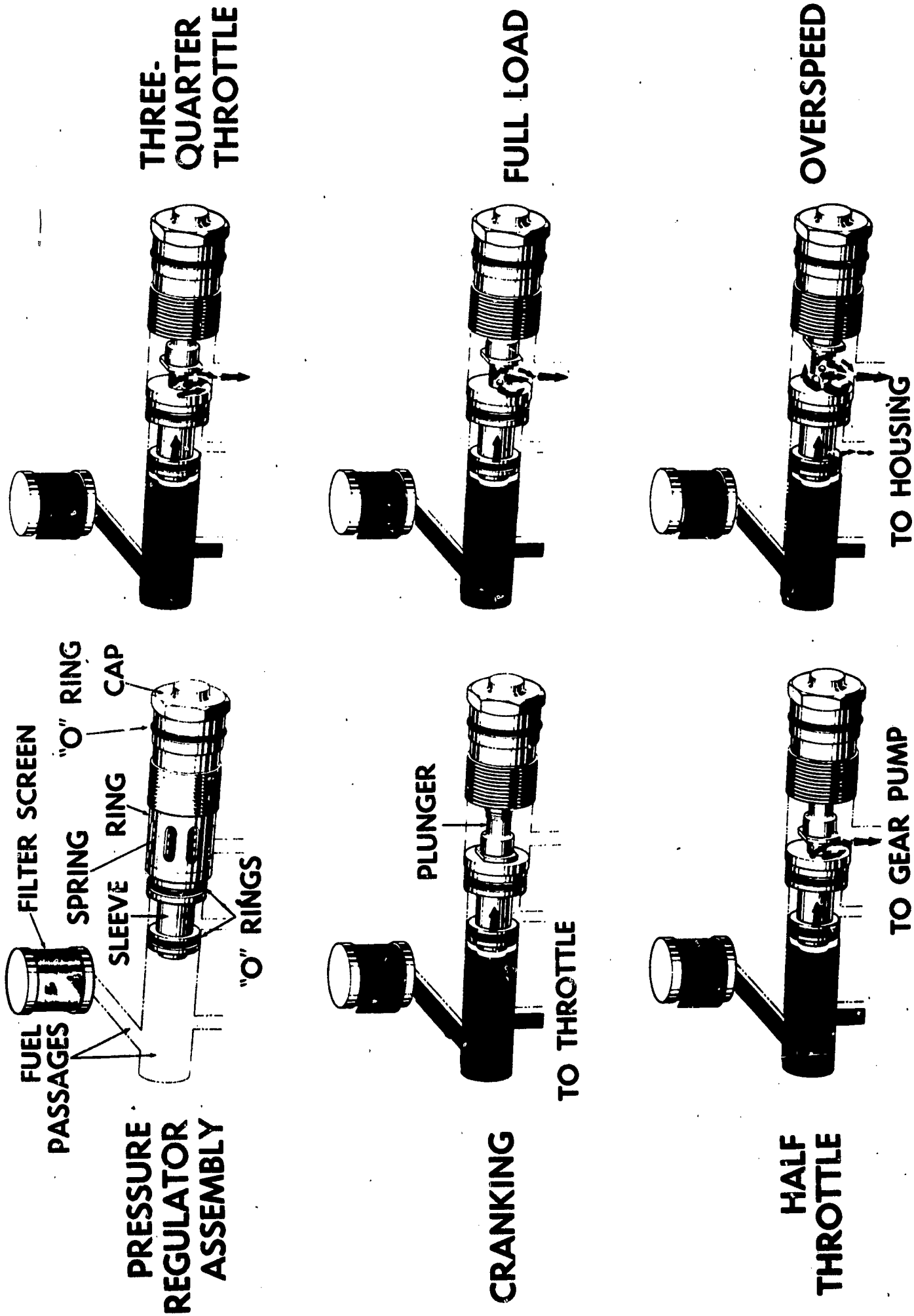

Plate VIII PTR fuel pump pressure regulator cycle

AM 1-13 D
3/11/66

OPERATION OF THE CUMMINS PT FUEL SYSTEM COMPONENTS

Human Engineering Institute

Press A 2 Check to be sure that timer is OFF.

1

This film is designed to build up your knowledge of the Cummins PT fuel system. There will be a review of what happens inside the engine and how the fuel is controlled by the PT system during operation. The difference between PTR and PTG will be explained and how the two types are used for different applications. Such terms as fuel manifold pressure, engine torque, bypass holes, etc., will be explained again to be sure they are understood.

Press A 7

1

We have learned that the Cummins engine is different from the GM engine in that each stroke made by a Cummins engine (1) a power stroke. Also that the Cummins engine functions part time as a (2) whereas the GM engine does not.

Choose the words that best fit the blanks:

- A. (1) is (2) pump 4
- B. (1) is not (2) pump 5
- C. Neither A or B. 4

1

No. You are incorrect. The four stroke engine does operate part time as a pump during the intake and exhaust strokes. Therefore each stroke in a 4 cycle engine is not a power stroke.

Press A 1

1

OK. There are four distinct strokes that a 4 cycle engine has: intake, compression, power and exhaust. On which stroke are the intake valves open?

- A. Compression 6
- B. Exhaust 7
- C. Intake 8

1

No. The valves are not open during the compression stroke. If the intake valves were open at this time, the engine would not fire.

Press A 8

1

No. The intake valves are not open during the exhaust stroke. If this happened, exhaust gases would be expelled from the intake valves. There is only one stroke when the intake valves are open; this is during the intake stroke.

Press A 8

1

OK. The intake valves are open only during the intake stroke.

During what two strokes are both the intake and exhaust valves closed?

- A. Exhaust, power. 9
- B. Compression, exhaust. 9
- C. Power, compression. 10

1

-10

No. You are incorrect. The only two strokes when both valves are closed are the power and compression strokes. If either of these valves were open during these two strokes, the engine could not operate.

Press A 10



1

OK. Only during the power and compression strokes are both valves closed. At the end of the compression stroke, the air in the chamber has been forced by the piston to occupy a space about one-fifteenth as great in volume as it occupied at the beginning of the stroke. Compressing air into this small of a place causes the temperature of that air to rise. Near the end of the compression stroke, the pressure is approximately 500 to 600 pounds per square inch, and the temperature of the air is about 1000 F.

Press A 12

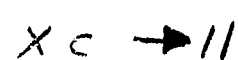

2

You have answered one or more of the questions in this sequence of material wrong. Before going on to other material, try these questions again. If you fail to answer them correctly again, check your class text AM 1-11 (first part) on the two stroke and four stroke cycle engine.

Press A 13

2

At this temperature and pressure of the air, and when the piston is at the right position in the cylinder, the fuel is sprayed into the chamber. This fuel is sprayed into the cylinder through the injector. This is called fuel (1) and is accomplished by rotation of the (2).

- A. (1) metering; (2) governor. 13
- B. (1) atomization; (2) pump. 14
- C. (1) timing; (2) cam shaft. 15

2

No. You are incorrect. Remember, we said metering of fuel is related to the amount of fuel injected.

Here we are concerned with when the fuel is injected, or timing of the fuel. Try this question again.

Press A 12

2

No. You are incorrect. Remember, we said that atomization had to do with breaking up of the fuel as it entered the combustion chamber. Try this question again. Think.

Press A 12

2

OK. The injector is the mechanism that contains the fuel, but the cam shaft's rotation determines when this fuel will be injected. This is timing.

There are two types of PT fuel pumps, the PTG, and the PTR. The PTG stands for governor controlled and the PTR stands for pressure regulator controlled.

Press A 16

2

The PT -(type R) fuel pump can be identified by the presence of a fuel return line, from the top of the fuel pump housing to the supply tank. The pump assembly has four main units:

1. The gear pump draws fuel from the supply tank, forcing it through the pump filter screen into the pressure regulator valve.
2. A pressure regulator limits the pressure of the fuel to the injectors.
3. The throttle provides manual control of fuel flow to the injectors under all conditions in the operating range.
4. The governor assembly controls the flow of fuel at idle and at maximum governed speed.

Press A 17

2

DIDACTOR

FILM NO. AM 1-13 D
3/ 11/ 66

17
In the PTR pump, the pressure regulators, which are unique to the R type _____

- A. control the flow of fuel between idle and maximum speed. 18
- B. draw fuel into the pump housing. 17
- C. limit the pressure of the fuel to the injectors. 20

2

17
No. You are confused. The governor controls the flow of fuel between idle and maximum speed. Try this question again.

Press A 17

2

19
No. You are incorrect. The fuel pump draws fuel into the pump housing from the fuel tank. Try this question again.

Press A 17

2

20
OK. The pressure regulator controls the pressure of the fuel going to the injectors. It functions as a bypass valve. When the pressure from the pump exceeds the pressure of the spring in the regulator, the fuel is bypassed to the suction side of the pump.

Press A 21

2

21
The PT -(type G) fuel pump can be identified by the absence of the return line at the top of the fuel pump. The pump assembly is made up of three main units:

1. The gear pump draws fuel from the supply tank and forces it through the pump filter screen to the governor.
2. The governor controls the flow of the fuel from the gear pump, as well as the maximum and idle engine speeds.
3. The throttle provides manual control of fuel flow to the injectors under all conditions in the operating range.

An important point to remember between the "R" and "G" type pumps is that the governor on the "G" functions as it does in the "R" and also serves to control the flow of fuel to the injectors, taking the place of the pressure regulator.

Press A 22

2

22
The gear pump and pulsation damper located at the rear of the pump perform the same on both the R and G models. The gear pump is driven by the pump main shaft and contains a single set of gears to pick up and deliver fuel throughout the fuel system. The pulsation damper mounted to the gear pump contains a steel diaphragm which absorbs pulsations and smooths fuel flow.

The "R" type pump can be identified by _____

- A. a governor assembly. 23
- B. a return line at the top of the pump. 24
- C. a simple gear pump without a pulsation damper. 25

2

23
No. You are not reading very carefully. Before trying this question again, review what's been said about the two types.

Press A → 16

2

24
OK. The return line to the suction side of the gear pump is unique to the "R" type.

25
Although the primary function of the pressure regulator, on the "R" type, is to control the fuel manifold pressure, it also provides an adjustment of manifold pressure, it compensates for changes in fuel oil temperature, it provides for engine torque characteristics, and it prevents excessive gear pump pressures. Let's see why.

Press A 25

2

25

We said the pressure regulator controls and limits gear pump fuel pressure through a bypass system.

Plate I shows how this is possible. The bypass valve sleeve and the bypass valve plunger form a valve, which through a spring force, prevents free movement back and forth. The plunger has drilled holes and slides in and out of the sleeve. If the spring holds the plunger all the way in, all holes are sealed, preventing fuel from returning to the pump.

Press A 26

2

26

Increased fuel pressure in the gear pump forces the plunger to move into the valve sleeve against the resisting spring force. This movement opens some of the bypass holes, which return some of the fuel to the pump, see Plate II.

One of the functions, then, that the pressure regulator performs is to _____

- A. smooth out the fuel flow. 27
- B. provide a means for the fuel to bypass the pump. 28
- C. provide a means for an adjustment of manifold pressure. 29

2

27

No. You are not reading very carefully. The pulsation of the fuel flow is compensated for by the pulsation damper behind the pump.

Try this question again.

Press A 26

2

28

No. You are incorrect. The fuel cannot bypass the pump; there would be no fuel flow. Try this question again. Think.

Press A 26

2

29

OK. One of the functions is to provide a means for adjustment of manifold pressure. Plate III shows how this can be accomplished. The fuel adjusting plunger is a nylon plunger located in the end of the bypass valve plunger. It is held in place by a cap and lock washer. Fuel pressure is adjusted by the amount the plunger covers the fuel adjusting holes.

Shims placed under the head of the plunger limit the distance the plunger projects into the bypass valve plunger. Do not confuse the spring-load shims in Plate I with these shims.

Press A 30

2

30

Adding shims increases the exposed area of the fuel adjusting holes, this would (1) _____ the fuel manifold pressure. Removing shims would (2) _____ fuel manifold pressure by covering up the holes.

- A. (1) increase (2) reduce 31
- B. (1) reduce (2) increase 32
- C. (1) reduce (2) reduce 31

2

31

No. You are incorrect. If more holes were exposed by adding shims, this would mean that more fuel would _____

- A. flow back to the pump. 32
- B. flow to the injectors. 34
- C. flow back to the filter. 33

2

32

Correct. The more holes that are exposed, the more fuel flows back to the pump.

To reduce manifold pressure then, you would _____ shims to compensate for the pressure.

- A. add 35
- B. remove 34

2

33

No. You are incorrect. The fuel flows in one direction, from the pump, through the filter, to the pressure regulator and on. Review a couple of frames and read carefully.

Press A 29

2

34

No. The exposed holes are for allowing excess fuel to flow back to the pump. Review a couple of frames and see if you can understand it. Read carefully.

Press A 29

2

35

OK. Now you're getting it.

There are three types of holes located in the bypass valve plunger: the fuel adjustment holes to regulate fuel manifold pressure, torque holes for engine torque characteristics, and dump holes to prevent excessive gear pump pressures.

The fuel adjusting holes are first to appear and are evenly spaced around the plunger, immediately next to its shoulder. The dump holes appear last and are the large holes near the end of the plunger. The torque holes depend upon the engine application and cannot be described by number, size, or location except that they are located between the fuel adjustment and dump holes.

Press A 36

2

36

Plate VIII shows the fuel flow through the pressure regulator at various stages of engine operation. Notice that there is always some fuel flowing to the fuel manifold. Also that the dump hole is exposed only in an overspeed condition. These holes are the last to open, dumping large amounts of fuel back to the fuel pump. Relief of excess pressure is necessary to prevent

- A. damage to the injectors. 38
- B. damage to the gear pump. 38
- C. damage to the relief valve. 38

2

38

No. You are incorrect. The answer required here was that damage to the pump would occur, because in positive displacement pumps there is no slippage of the fluid. If there is no escape for the fluid under high pump pressure, damage may result to the pump.

Press A 39

2

39

OK. Damage to the gear pump is correct. Under excess pressure, since this is a positive displacement pump where little or no slippage occurs, the pump can be damaged if there is no escape for the liquid.

In this type of gear pump we know that the suction side of the pump is created by the parting of the gears, and that the pressure side is caused by the meshing of the gears.

Press A 41

XC → 40

40

You have answered one or more of the questions in this sequence of material incorrectly. It will be best if you review it again to be sure it is clear in your mind. Take your time and read carefully.

Press A → 24

2

41

Another function that the pressure relief valve performs is compensating for changes in fuel oil temperature. As we have learned in previous units, the viscosity of diesel fuel decreases with increase in temperature. As the fuel gets hot, it flows more freely.

As the fuel is gaining in temperature, the fuel adjusting plunger also gains in temperature and expands. As it expands, it bypasses less fuel.

The reverse is also true: as the fuel cools off, the plunger contracts, allowing more fuel to flow.

Press A 42

3

42

Look at Plate III. If a problem developed of too much fuel getting past the pressure regulator when the engine is hot, which of the following corrections could be made?

- A. Decrease the number of shims behind the plunger. 45
- B. Increase the number of shims behind the plunger. 47
- C. Change the size of the plunger. 44

3

43

No. Look at Plate III closely. Notice that the plunger slides in and out of the housing. If the shims were increased, wouldn't more of the fuel adjustment holes be exposed? The answer is decrease the number of shims.

Press A 45

3

44

No. You are incorrect. We haven't mentioned changing the plunger in our discussion. The answer we wanted is: the shims should be decreased so that more of the adjustment holes would be covered; thus less fuel would flow.

Press A 45

3

41

OK

In both fuel pumps, the throttle provides a means for the operator to manually control engine speed above idle, as required by varying operating conditions of speed and load. In the PT-(type R) fuel pump, fuel flows past the pressure regulator to the throttle shaft. Under idling conditions, fuel passes around the shaft to the idle port in the governor barrel. For operation above idle speed, fuel passes through the throttling hole in the shaft and enters the governor barrel through the main fuel port.

In the PT-(type G) fuel pump, fuel flows through the governor to the throttle shaft. At idle speed, fuel flows through the idle port in the governor barrel, past the throttle shaft.

To operate above idle speed, fuel flows through the main governor barrel port to the throttling hole in the shaft.

Press A 46

3

46

We can say then that the throttle is a means for the operator to maintain engine speed _____

- A. at idle and high speeds of the engine. 47
- B. between idle and high speed ranges. 48
- C. only at speeds below idle and above high speeds. 47

3

47

No. You are incorrect. We said the throttle enables the operator to control speeds between idle and maximum speeds. The governor controls speeds at idle and speeds at maximum.

Press A 48

3

48

OK. The idle and high speed mechanical governor is the type most used on off-highway equipment; see Plate IV. Remember, as we discuss this type of governor that it controls only maximum and idle speeds.

Fuel flow to the injectors passes through the governor barrel. Fuel enters the barrel through the idle and high speed ports, leaving through the discharge ports. The position of the relieved section of the governor plunger controls fuel flow through the governor barrel.

The centrifugal action of the governor weights applies force against the governor plunger. Governor plunger movement is resisted by the governor springs. At a given rpm the governor weight force equals the resisting spring force and brings the governor plunger to a balanced position. The position of the plunger in the governor barrel determines the fuel flow to the injectors.

Press A 49

3

49

Governor Starting Position: Fuel flow through the idle or high speed ports at cranking speed depends on throttle position. The governor weight force and the resisting

idle spring force position the governor plunger shoulders to allow full fuel flow through either port. With the throttle in closed position, fuel flows through the idle port.

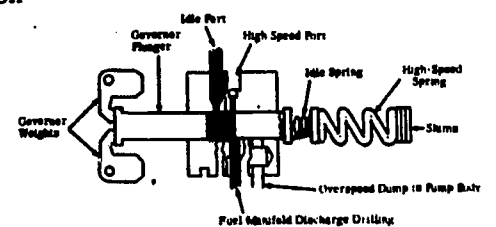

Press A 50

3

In the starting position, two forces are acting against the governor plunger, these are:

- A. the high-speed spring and the governor weight force. *51*
- B. the idle spring and the high-speed spring. *51*
- C. the governor weight force and the idle spring. *52*

3

No, You are not reading as carefully as you should. Remember there is a force on each end of the plunger trying to position it, Try this question again and look carefully at the picture.

Press A *50*

3

OK. The two forces acting against the plunger are the governor weights and the idle spring.

Governor Idling Position: The governor plunger controls engine speed by restricting flow in the idle port, see picture. The plunger allows fuel to flow in both ports. When the throttle is in the closed position, most idle fuel enters the idle port. Throttle leakage through the high speed port accounts for the remainder of the idle fuel.

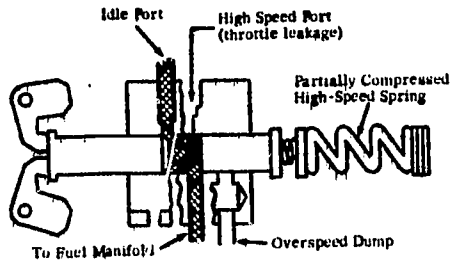

3

Press A *53*

Governor weight force and resisting idle spring force, at idle speed, position the governor plunger shoulder under the idle port, see picture. Fuel flow past the governor plunger shoulder maintains idle speed. Note the high speed spring is not affected by governor plunger movement of cranking and idle speeds. The spring is not affected until approximately 700 rpm when the idle spring compresses and further movement in this direction acts on the high speed spring.

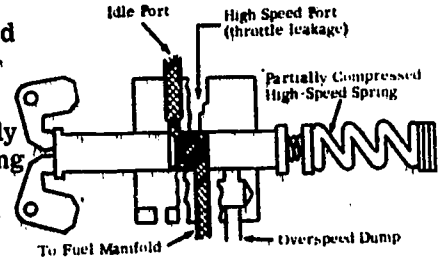

Press A *54*

3

In the idling position, the governor weights are (1); allowing fuel to flow past the (2); through the (3).

- A. (1) in; (2) plunger; (3) idle port. *57*
- B. (1) out; (2) plunger; (3) idle port. *55*
- C. (1) in; (2) plunger; (3) throttle leakage. *56*

3

No. You are incorrect. At idle speed, the engine is turning at a slow rate, allowing the governor weights to move in. This allows fuel to flow through the idle port even though the throttle is closed.

You have answered one or more of the questions in this sequence of material incorrectly - let's review - read carefully.

Press A *57*

3

You are partially correct, there is always some fuel flowing past the throttle even at idling speeds. However, the answer that best fits the question here is through the idle port.

Press A *57*

3

OK. Let's discuss another position.

Governor at Full or Intermediate Loads. When the throttle is open, fuel flows through the high speed ports and the engine accelerates, depending on the load; see picture. In this position the idle port is closed and all fuel flows from the high speed port manifold. The reduced-diameter section of the plunger allows an unrestricted fuel flow from idle to governed speed.

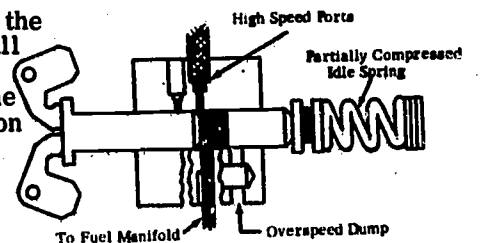

Press A *58*

4

XC -> 52 1/2

You have answered one or more of the questions in this sequence of material incorrectly. It will be best if you review it again to be sure it is clear in your mind. Take your time and read carefully.

Press A → 41

3

Fuel manifold pressure in this range is controlled by the throttle. At governed or rated speed the governor plunger shoulder moves as far as possible without restricting fuel flow through the governor barrel. Further governor plunger movement restricts fuel flow, and dumps fuel by over-speed dump action.

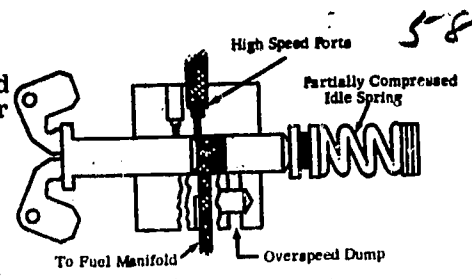

In the sketch, fuel is flowing only from the high speed port because

- A. the dual spring force has overcome the governor weight force.
- B. the springs have compressed enough to allow the plunger to uncover the port.
- C. fuel flows only from the high speed port.

58
61
4 60

No. Try this question again and notice the position of the governor fly weights. Remember, the governor shaft turns faster as the engine turns faster.

Press A 58

4

No. Fuel does not flow only from the high speed port. Remember where the fuel flows at the idle position. Try this question again.

Press A 58

4

OK. The more the flyweights move out, the more the spring pack is compressed.

Look at this sketch of the high idle condition. The plunger has partially covered up the high speed ports, and has now opened the dump port. This is an indication that the engine is approaching an overspeed condition.

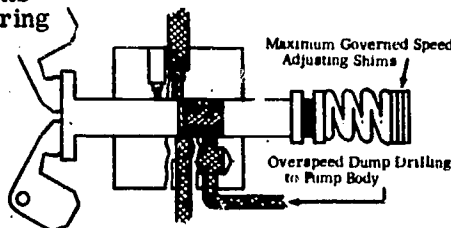

Also notice in the sketch that this condition can be adjusted by adding or subtracting shims.

Press A 62

4

Here we see the governor in an overspeed condition. This may occur when the vehicle is moving down a hill. Notice the ports are both closed by the plunger. It is easy to see, now, that when shims are added, engine speed is increased.

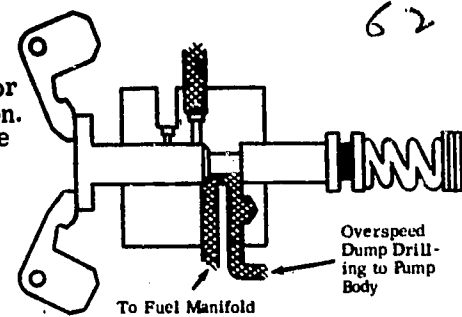

Cummins PT fuel pumps are color coded according to size of pump and strength of governor spring. Check the maintenance manual for this information.

Press A 63

4

Before moving on to the air-operated road speed governor, let's review what we have learned.

We can say that fuel manifold pressure is controlled by the combined forces of the _____ (1) _____ and _____ (2) _____.

- A. (1) pump (2) governor. 64
- B. (1) pump (2) throttle. 65
- C. (1) governor (2) pressure regulator (PTR only). 66

4

Press A 66

4

65

No. There must be a way to return the excess fuel developed by the pump. The throttle is only a means to allow fuel to flow to the governor. Try this question again.

Press A 63

4

66

OK.

Cummins PT fuel pump units are color coded according to _____

- A. capacity of gear pump and size of pressure regulator (PTR type). 67
- B. the number of shims (by thickness) in the governor spring pack. 67
- C. capacity of gear pump and strength of spring pack in governor (PTG type). 68

4

67

No. You have chosen the wrong answer. Cummins PT pumps are painted different colors to distinguish the differences in gear pump capacities and the strength of springs in the governor. It is very important that the pump match the engine size and application. Let's review this material again to be sure you have it.

Press A 68

4

OK. Let's talk about the air actuated road speed governor.

The air operated road speed governor has two major components: (1) an air cylinder on the fuel pump, and (2) an air control valve on the transmission. The air control valve performs two functions; (1) it transmits air under pressure to the air cylinder in low and intermediate gears, and (2) it provides an air passage for bleed-out in the top transmission gear. The air cylinder positions the engine fuel pump governor springs to provide two governor positions directly affecting speed. In low and intermediate gears, the engine reaches normal full load speed. In top gear, the governor positions allow the engine to reach a desired cruising speed, such as 1800 on a 2100 rpm engine.

Press A 69

xc → 68 1/2 5

68 1/2

OK.

Let's review the last two or three frames to be sure you have this straight.

Press A → 61

5

65

The air operated road speed governor limits maximum speed by reducing governed engine speed in the maximum transmission cruising gear. This is accomplished by an air cylinder on the PT fuel pump governor spring pack connected to an air valve, or valves, on the transmission gear box, actuated by the gear shifting member; see Plates V and VI. On automatic transmissions, actuation is accomplished by the transmission linkage.

With the transmission in a low intermediate gear, the plunger in the air valve on the transmission is held in, and air flows to the air cylinder on the fuel pump; see Plate VI.

Press A 70

5

70

Air pressure against the fuel pump air cylinder plunger compresses the maximum speed governor spring which permits engine speed to rise as the throttle is advanced until the governor plunger cuts off the fuel. This engine speed is that normally reached with any automotive type fuel pump operating at engine rated speed.

When the transmission is shifted to the top gear, the shift rod cutout allows the air valve plunger to move out, and the air bleeds out of the system to the transmission breather.

No air is against the fuel pump cylinder, and the maximum speed governor spring tension is reduced. The governor plunger cuts off fuel to the engine at a lower speed. This speed is adjusted to a predetermined value by shimming the air cylinder plunger.

Press A 71

5

71

The air control valve mounted on the transmission is actuated by _____

- A. the changes in air pressure. 72
- B. the shifting of the transmission. 74
- C. the PT fuel pump. 73

5

72

73

No. You are incorrect. The air control valve is the mechanism which regulates the air pressure, letting it flow or stopping it from flowing. The control valve is actuated by other means. Try this question again.

No. You are incorrect. The fuel pump has nothing to do with actuating the air control valve. The purpose is to provide an outside means of controlling the fuel pump. Try this question again.

Press A 71

Press A 71

5

5

74

75

OK. The shifting of the transmission actuates the air control valve, as shown in Plate VI.

The purpose of the air cylinder mounted on the fuel pump is to _____

No. The plunger in the governor allows fuel to flow from the dump only in an overspeed condition. We are thinking here of a mechanism that controls the plunger indirectly. Try this question again.

- A. allow more fuel to flow from the overspeed dump. 75
- B. eliminate the shims in the fuel pump. 76
- C. compress the high speed spring at certain speeds. 77

Press A 74

5

5

76

77

No. The shims may have to be adjusted to accommodate the air cylinder mechanism but they are still required. Try this question again.

OK. The governor spring pack is compressed at certain speeds, which retards the plunger and permits engine speed to rise as the throttle is advanced in the low and intermediate gears. When the transmission is shifted into high gear _____

Press A 74

- A. additional air is forced into the air cylinder. 78
- B. air is allowed to bleed out of the air cylinder. 80
- C. the air valve plunger is depressed. 79

5

5

78

79

No. All the air that's available was forced into the air cylinder during the low and intermediate speeds. When the transmission is shifted into high gear, the air is bled off the air cylinder, allowing the high speed spring to expand. This positions the governor plunger again, which allows the engine to reach a desired cruising speed.

No. When the transmission is shifted into high gear, the air valve plunger is released, not depressed; see Plate VI. The release of this plunger opens the air system and allows air to be bled from the air cylinder, which in turn relaxes the high speed governor spring allowing the engine to reach the desired cruising speed.

Press A 80

Press A 80

5

5

80
OK. You are doing fine. Let's move on and discuss another important component of Cummins' turbocharged engines, the ANEROID control.

As mentioned earlier in the class text, the aneroid control is used exclusively on the turbocharged Cummins engines and is a fuel bypass control that responds to air manifold pressure except at engine cranking speeds. The aneroid limits fuel manifold pressure when the air manifold pressure is low. When accelerating from speeds below normal operating range, manifold air pressure is not sufficient to support combustion because the turbocharger is not effective until higher engine speeds are attained.

Press A 82

XC → 81⁶

81
You have answered one or more of the questions in this sequence of material incorrectly. It will be valuable for you to review this information again before going on to the last portion of the lesson. Read carefully and take your time in answering the questions.

Press A → 88

6

82
Also in extreme cold weather, when the oxygen content of the air is high, the aneroid control stabilizes the air fuel ratio by sensing air manifold pressure and creating a bypass for excess fuel to flow back to the inlet side of the pump. Plate VII shows how this is accomplished. The sleeve and shaft mechanism operate somewhat like the throttle. except that turning of the shaft is actuated by air pressure from the manifold. The less pressure there is in the manifold, the more fuel is bypassed back to the pump.

Press A 83

6

83
We can say then that the aneroid control is a device

- A. to limit the amount of air pressure in the manifold. 84
- B. to limit the amount of fuel during cranking of the engine. 81
- C. to retard the fuel supply when accelerating from low to high speeds. 86

6

84
No. The aneroid control does not affect the air pressure in the manifold. It does use the air pressure, though, to control the amount of fuel flowing to the fuel manifold.

Press A 86

6

85
No. You are incorrect. The aneroid control check valve (see Plate VII) prevents fuel from being bypassed at engine cranking speeds. If this check valve sticks shut, the engine will not start. Try this question again.

Press A 83

6

86
OK. The aneroid control limits fuel flowing to the fuel manifold during low air manifold pressure. The less pressure there is, the less fuel flows to the manifold.

As we learned in previous Units, an excess amount of fuel in the combustion chamber in relation to the amount of air present can cause

- A. excessive lubricating oil consumption. 87
- B. rough engine operation. 88
- C. excessive smoking. 89

6

87
No. Excessive oil consumption could be caused by worn main or rod bearings, improper type of oil, oil level too high in crank case or other things, but not by an excessive amount of fuel. Too much fuel in relation to the amount of air causes excessive smoking. Also if this condition continues, excessive fuel may seep past the rings and dilute the lube oil.

Press A 85

6

DIDACTOR

FILM NO. AM 1-13 D
3/ 11/ 66

88

No. Rough engine operation could be caused by imperfect injection, by the timing being off, water in the fuel, the wrong fuel, or the valves sticking, but not by an excessive amount of fuel. Too much fuel in relation to the amount of oil causes excessive smoking.

Press A 85

6

85

OK Not only does the aneroid control prevent excessive smoking, but if too much fuel is continually flowing to the manifold, and into the pistons, a lubricating oil dilution or a low power condition could occur.

In the aneroid control, the sleeve and shaft will control the flow of fuel in the same way as the _____ does in the PT pump.

- A. air cylinder 90
- B. throttle shaft 92
- C. pressure regulator 91

6

90

No. You have the air operated road speed governor pump confused with the aneroid control. The throttle shaft in the PT pump is the answer we wanted here.

Press A 92

6

91

No. The pressure regulator controls fuel pressure but it is actuated because of engine speed, not air pressure in the air manifold. The throttle shaft in the PT pump is the answer we wanted here.

Press A 92

6

92

OK. The throttle shaft rotates and allows fuel to flow to the governor when the operator wishes more speed. The shaft in the aneroid rotates and allows fuel to flow back to the pump when low manifold air pressure exists.

That completes this lesson.

PRESS REWIND

X C → 93
6

93

You have answered one or more questions incorrectly in this last sequence of material. Review the last few frames and read carefully about the aneroid control system.

Press A → 80

6

HUMAN
ENGINEERING
INSTITUTE

2341 Carnegie Ave
Cleveland, Ohio 44115

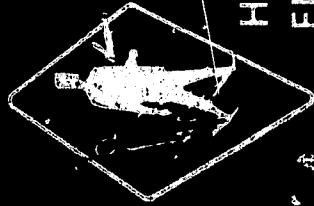

AM 1030

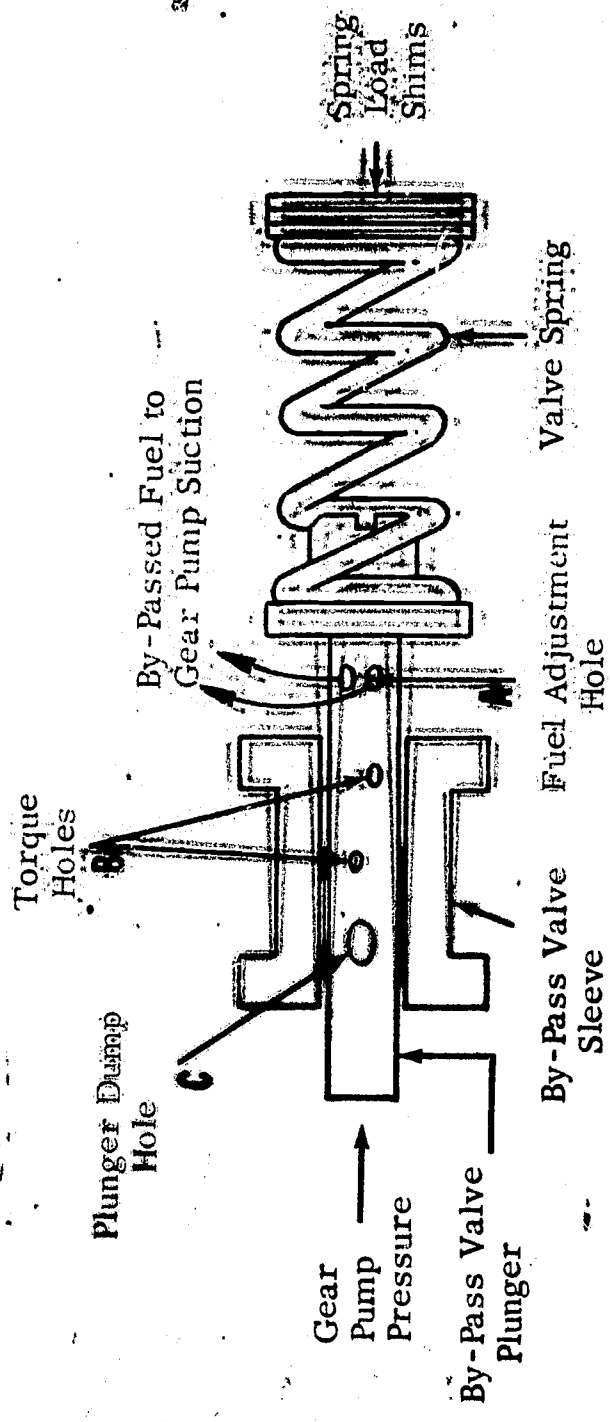
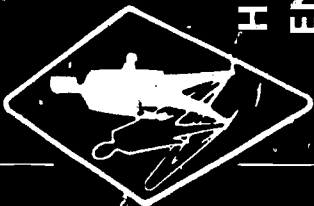

Fig. 6. Pressure regulator by-pass valve



**HUMAN
ENGINEERING
INSTITUTE**

2341 Carnegie Ave
Cleveland, Ohio 44115

AM 12/18 ©

9

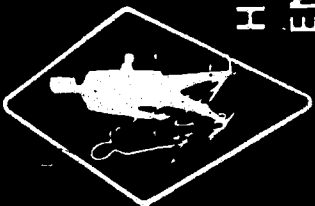
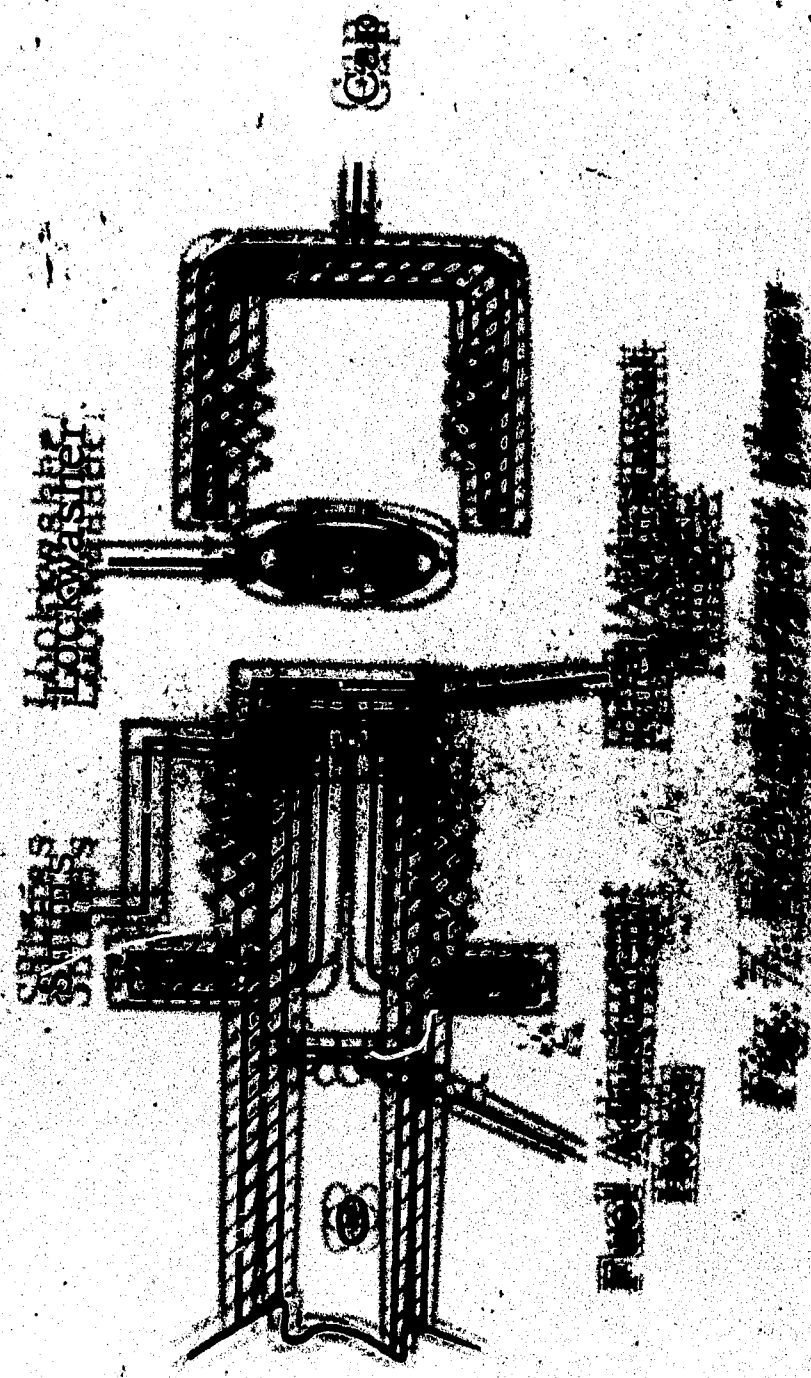

**HUMAN
ENGINEERING
INSTITUTE**

241 Carnegie Ave
Cleveland Ohio 44115

AM 1-18-0

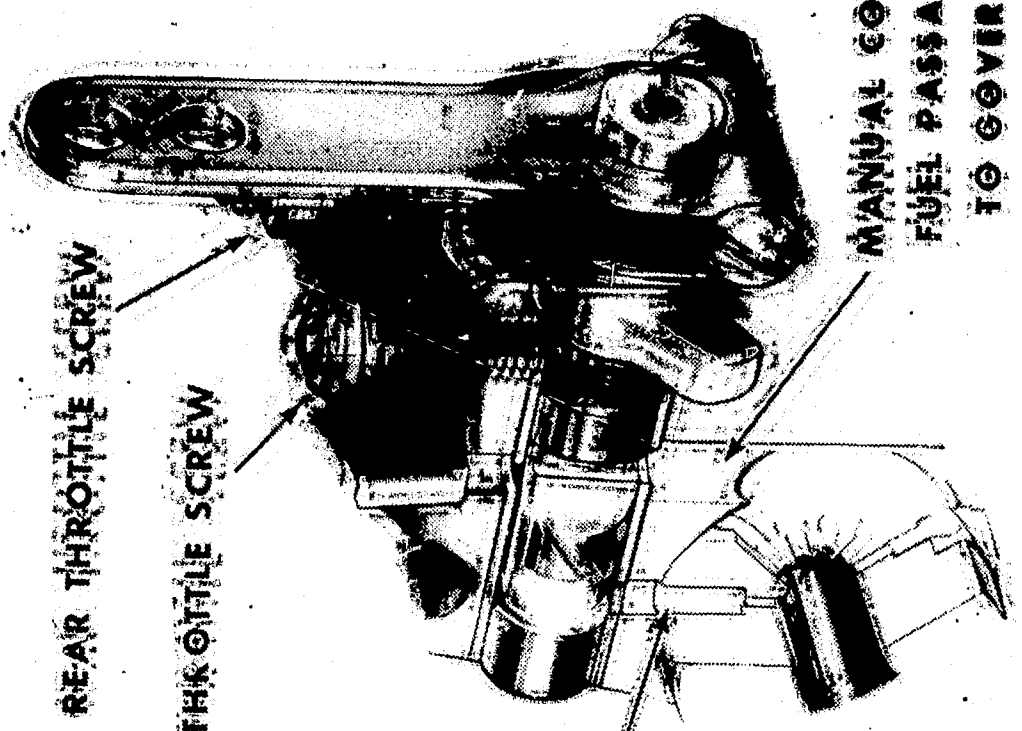

REAR THROTTLE SCREW

FORWARD THROTTLE SCREW

IDLE PASSAGE 'B'
TO GOVERNOR
IDLE PORT

MANUAL CONTROL
FUEL PASSAGE 'A'
TO GOVERNOR
HIGH SPEED PORTS

ENGINEERING
TE

411 13 5

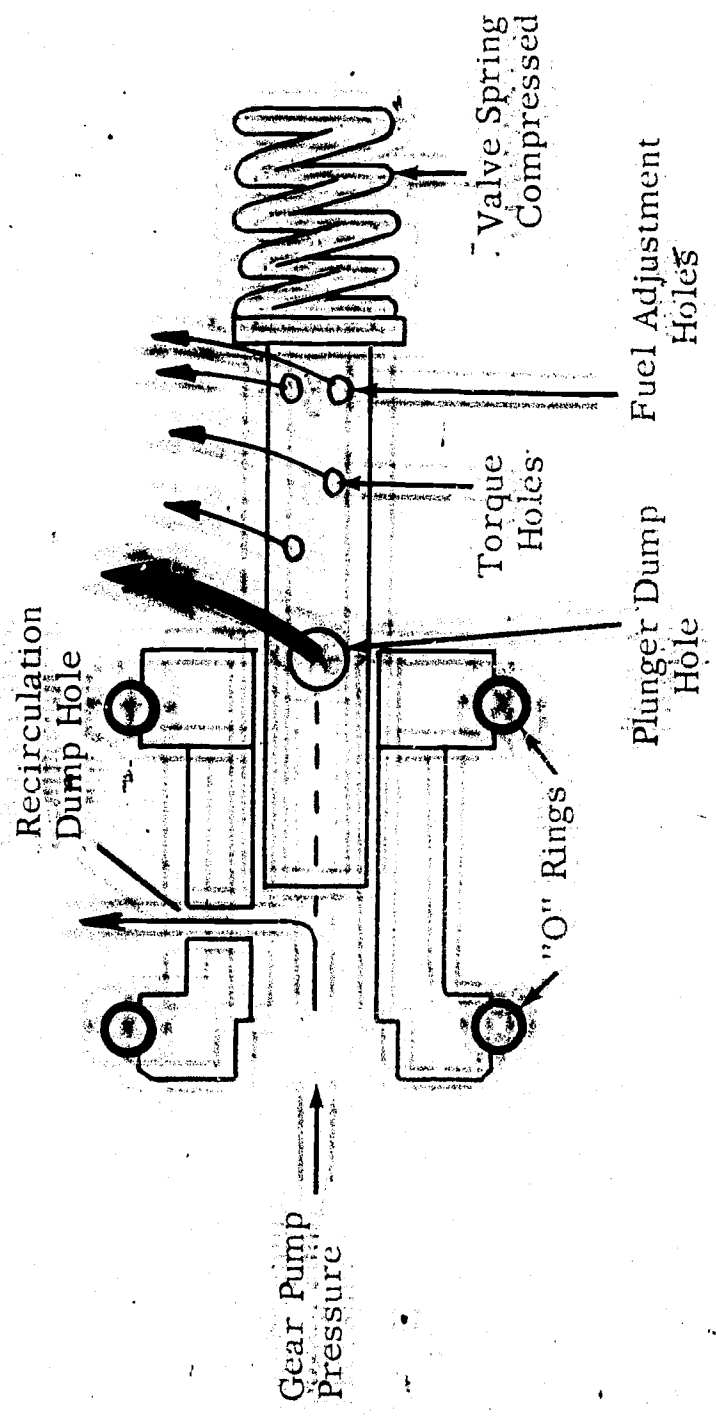
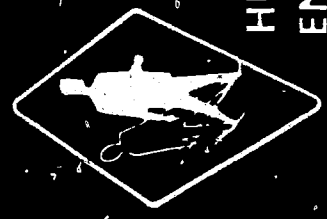

Fig. 11. Recirculating and dumping fuel



HUMAN
ENGINEERING
INSTITUTE

2341 Carnegie Ave
Cleveland, Ohio 44115

INSTRUCTOR'S GUIDE

I -- Maintaining the Fuel System (Part III)
Cummins Diesel Engines

Title of Unit: II -- Radiator Shutter System AM 1-13
3-15-66

FIRST: Be sure all questions have been answered that students might have on home study units.

OBJECTIVES: By the end of class, each student should know:

PART I

1. Where the gear pump is located and what drives it.
2. The purpose of the magnet in the filter.
3. The primary purpose of the pressure regulator.
4. How the fuel manifold pressure is controlled.
5. What a by-pass hole is.
6. Something about engine torque characteristics.
7. What is meant by dumping fuel.
8. What part the throttle plays in the fuel system.
9. What the fuel pump test stand is used for.
10. How to operate the fuel pump test stand.
11. How to test the pump after it is installed.
12. As much about the fuel injector tests as he does about the fuel pump tests.
13. How to identify a Cummins fuel injector.

PART II

1. What advantages the shutter system has.
2. What the shutter system components are.
3. How it operates.
4. How it can be adjusted.
5. What the seasonal adjustment consists of.

LEARNING AIDS suggested:

- WALL CHARTS:**
1. Bulletin #983475, PTG FUEL PUMP FLOW
 2. Bulletin #983477, PTG FUEL PUMP
(Mechanical Variable Speed Governor).

-
- VUE CELLS:**
1. AM 1-13 (1) Fuel Pump Pressure Regulator Cycle
 2. AM 1-13 (2) Pressure Regulator By-pass Valve
 3. AM 1-13 (3) Fuel Adjustment Plunger
 4. AM 1-13 (4) Fuel Pump Throttle
 5. AM 1-13 (5) Recirculating and Dumping Fuel

MAINTENANCE MANUALS:

1. CUMMINS - V12 Series Operator's Manual
 2. CUMMINS - V12 Series Shop Manual
-

FILM STRIPS:

1. Theory of the PTG Fuel System -- Film #985509
2. Operations and Adjustments of the PTG Fuel Pump -- Film #985512

NOTE: Records are available to accompany the above films.

CUTAWAYS:

Fuel Injector or obtain one from shop and pass it around the class.

NOTE: Consult the local Cummins distributor for the possibility of obtaining the above.

QUESTIONS FOR DISCUSSION AND GROUP PARTICIPATION:

PART I

1. How does the fuel pump location on the Cummins engine differ from that of the GM engine? Explain.
2. What type of gear pump is the Cummins? Positive displacement, non-positive displacement, spur, helical, etc.
3. After the fuel enters the pump, where does it go first?
4. What is the primary function of the pressure regulator?
5. What keeps the total fuel output of the pump from going to the injectors?
6. What keeps the fuel by-pass holes from being open all the time?
7. What are the three types of by-pass holes?
8. What is the purpose of the shims being added to the by-pass valve plunger?
9. What happens when the shims are removed?
10. What is meant by desired torque rise?

11. Name some of the causes of excessive gear pump pressure.
12. What item automatically releases excessive gear pump pressure?
13. How is a Cummins fuel injector identified?
14. What is a non-adjustable delivery injector?

PART II

1. How does the shutter system supplement the thermostats?
2. How does temperature affect the shutter system?
3. Why might a shutter be closed on a hot day?
4. Explain what function (C) has in Figure 12, of the text.
5. On what component of the shutter system is the bellcrank?

END

12-10-68