

R E P O R T R E S U M E S

ED 021 073

VT 005 656

AUTOMOTIVE DIESEL MAINTENANCE 1. UNIT II, MAINTAINING THE AIR SYSTEM--DETROIT DIESEL ENGINES.

HUMAN ENGINEERING INSTITUTE, CLEVELAND, OHIO

REPORT NUMBER FTAM-1-2

PUB DATE 27 SEP 65

EDRS PRICE MF-\$0.50 HC-\$2.40 58P.

DESCRIPTORS- *STUDY GUIDES, *TEACHING GUIDES, *TRADE AND INDUSTRIAL EDUCATION, *AUTO MECHANICS (OCCUPATION), *DIESEL ENGINES, ADULT VOCATIONAL EDUCATION, TRANSPARENCIES, PROGRAMED MATERIALS, INDIVIDUAL INSTRUCTION, INSTRUCTIONAL FILMS, PROGRAMED INSTRUCTION, MOTOR VEHICLES, EQUIPMENT MAINTENANCE,

THIS MODULE OF A 30-MODULE COURSE IS DESIGNED TO DEVELOP AN UNDERSTANDING OF THE OPERATION AND MAINTENANCE OF THE DIESEL ENGINE AIR SYSTEM. TOPICS ARE (1) OPERATION AND FUNCTION, (2) AIR CLEANER, (3) AIR SHUT-DOWN HOUSING, (4) EXHAUST SYSTEM, (5) BLOWER, (6) TURBOCHARGER, AND (7) TROUBLE-SHOOTING TIPS ON THE AIR SYSTEM. THE MODULE CONSISTS OF A SELF-INSTRUCTIONAL BRANCH PROGRAMED TRAINING FILM "DIESEL AUTOMOTIVE MAINTENANCE--DETROIT DIESEL AIR SYSTEM" AND OTHER MATERIALS. SEE VT 005 655 FOR FURTHER INFORMATION. MODULES IN THIS SERIES ARE AVAILABLE AS VT 005 655 - VT 005 684. MODULES FOR "AUTOMOTIVE DIESEL MAINTENANCE 2" ARE AVAILABLE AS VT 005 685 - VT 005 709. THE 2-YEAR PROGRAM OUTLINE FOR "AUTOMOTIVE DIESEL MAINTENANCE 1 AND 2" IS AVAILABLE AS VT 006 006. THE TEXT MATERIAL, TRANSPARENCIES, PROGRAMED TRAINING FILM, AND THE ELECTRONIC TUTOR MAY BE RENTED (FOR \$1.75 PER WEEK) OR PURCHASED FROM THE HUMAN ENGINEERING INSTITUTE, HEADQUARTERS AND DEVELOPMENT CENTER, 2341 CARNEGIE AVENUE, CLEVELAND, OHIO 44115. (HC)

STUDY AND READING MATERIALS

ED0037073

AUTOMOTIVE DIESEL MAINTENANCE

1

MAINTAINING THE AIR SYSTEM --
DETROIT DIESEL ENGINES

UNIT II

TABLE OF CONTENTS

SECTION A	OPERATION AND FUNCTION
SECTION B	THE AIR CLEANER OIL BATH CLEANER DRY TYPE CLEANER
SECTION C	AIR SHUT-DOWN HOUSING
SECTION D	EXHAUST SYSTEM
SECTION E	THE BLOWER
SECTION F	THE TURBOCHARGER
SECTION G	TROUBLE-SHOOTING TIPS ON THE AIR SYSTEM

PTAM 1-2
9/27/65

U.S. DEPARTMENT OF HEALTH, EDUCATION & WELFARE
OFFICE OF EDUCATION

THIS DOCUMENT HAS BEEN REPRODUCED EXACTLY AS RECEIVED FROM THE
PERSON OR ORGANIZATION ORIGINATING IT. POINTS OF VIEW OR OPINIONS
STATED DO NOT NECESSARILY REPRESENT OFFICIAL OFFICE OF EDUCATION
POSITION OR POLICY.

HUMAN ENGINEERING INSTITUTE

SECTION A -- OPERATION AND FUNCTION

In the scavenging process employed in all 71 Series engines, a charge of air is forced into the cylinder by the blower which thoroughly sweeps out all of the burnt gases through the exhaust valve ports. This air also helps cool the internal engine parts, particularly the exhaust valves. At the beginning of the compression stroke, therefore, each cylinder is filled with fresh, clean air for efficient combustion.

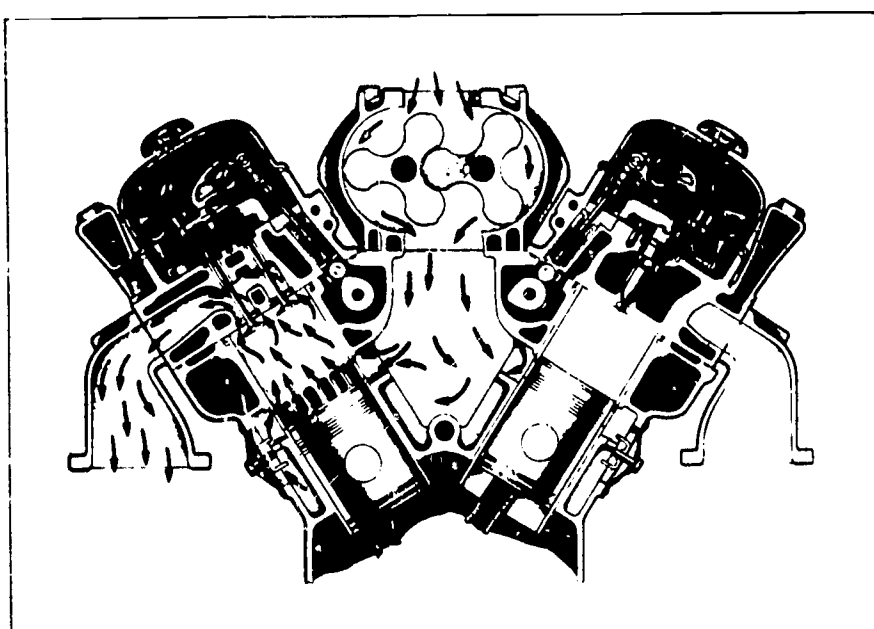

Fig. 1 - Air intake system through blower and engine.

The air, entering the blower from the air cleaner, is picked up by the blower rotor lobes and carried to the discharge side of the blower as indicated by the arrows in Figure 1 (V-7 Series) and in Figure 2 (In-Line 71 Series). At maximum engine speed the continuous discharge of fresh air from the blower creates an air pressure of approximately seven pounds per square inch in the air chamber of the cylinder block. This air sweeps through the intake ports, which start to open as the piston approaches the end of its downward stroke. The ports are closed off by the piston soon after the compression stroke begins.

CYLINDER INLET PORTS -- should the cylinder inlet ports become blocked with foreign material, the flow of air will be restricted. This will result in poor combustion and improper air scavenging which will cause a loss of power

and eventual build-up of carbon deposits on pistons and valves.

The condition of the cylinder ports can be visually checked by removing the air box covers and if necessary can be cleaned without removing the cylinder liners from the engine. To do this, remove the cylinder head and air box covers. Install the cylinder liner hold-down clamps and crank the engine until the piston is at the bottom of its stroke. Then, clean all ports with a pointed hardwood stick, taking care to remove all chunks of carbon that fall into the cylinder or air box. After cleaning the ports, check the inside of the liner around the ports for burrs. Remove burrs by sanding them with 250 grit emery paper.

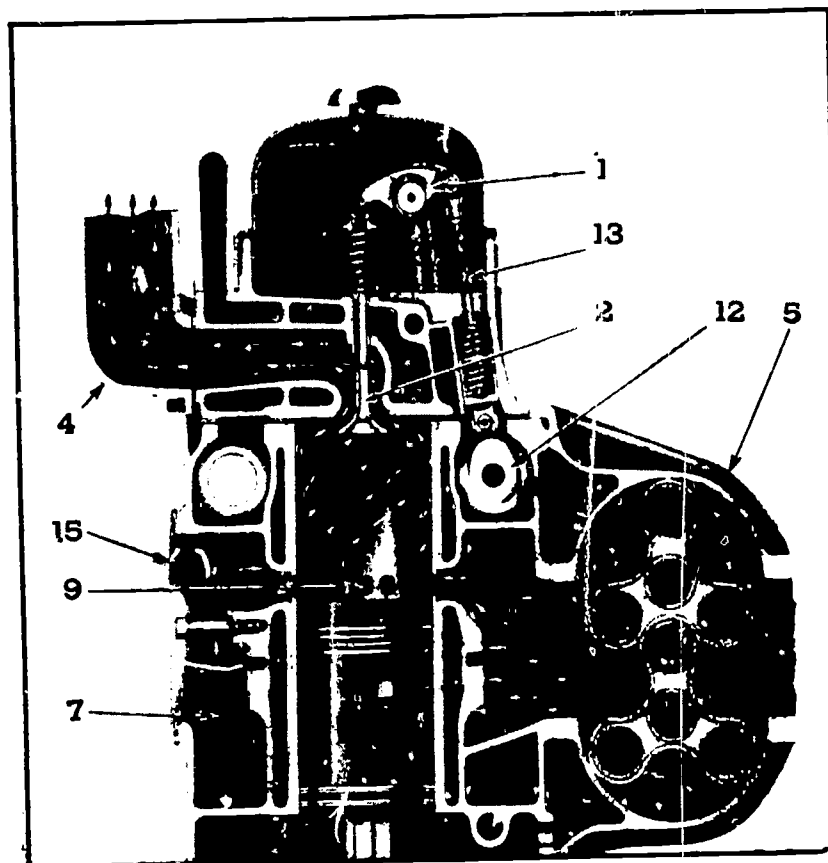

Fig. 2 - Air intake system through blower and engine.

- | | |
|-------------------------|-----------------------------------|
| 1. Rocker-Exhaust Valve | 9. Port-Admitting Air to Cylinder |
| 2. Exhaust Valve | 12. Camshaft |
| 4. Exhaust Manifold | 13. Push Rod |
| 5. Blower | 15. Cover-Hand Hole |
| 7. Air Box | |

Before replacing the air box covers, check the condition of the cover gaskets. Replace the gaskets if they are damaged or such that they would allow air to seep out of the air box. Check the machined surface outside of the air box windows for conditions which would prevent the cover gasket from making uniform, secure contact. The air box cover bolts should be tightened to proper torque specifications so a distortion is not set up in the cylinder block.

SECTION B -- THE AIR CLEANER

THE AIR CLEANER -- The oil bath type air cleaners are designed to remove

foreign matter from the air, pass the required volume of air for proper combustion and scavenging, and maintain their cleaning efficiency for a reasonable period of time before servicing.

The importance of keeping dust and grit-laden air out of an engine cannot be over-emphasized. Dust and dirt entering an engine will cause rapid wear of piston rings, cylinder liners, pistons and the exhaust valve mechanism resulting in a loss of power and high lubricating oil consumption. If dust and dirt are allowed to build up in the air cleaner passages, they will eventually restrict the air supply to the engine and result in heavy carbon deposits on pistons and valves because of incomplete combustion. The air cleaner must be able to remove fine materials, such as dust and blown sand, as well as coarse materials from the air.

OIL BATH AIR CLEANER -- In the oil bath air cleaners, Figure 3, the air is drawn through the air inlet hood and down through the center tube. At the bottom of the tube, the direction of air flow is reversed. Oil is picked up from the oil reservoir cup and the oil laden air is carried up into the separator screen. There the oil which contains dirt particles is separated from the air by collecting on the separator screen.

A low pressure area, see Figure 4, is created between the central tube and the separator screen. This low pressure area, plus the effect of gravity and the inverted cone shape of the separator screen, causes the oil and dirt mixture to drain to the center of the cleaner cup. This oil is again picked up by the incoming

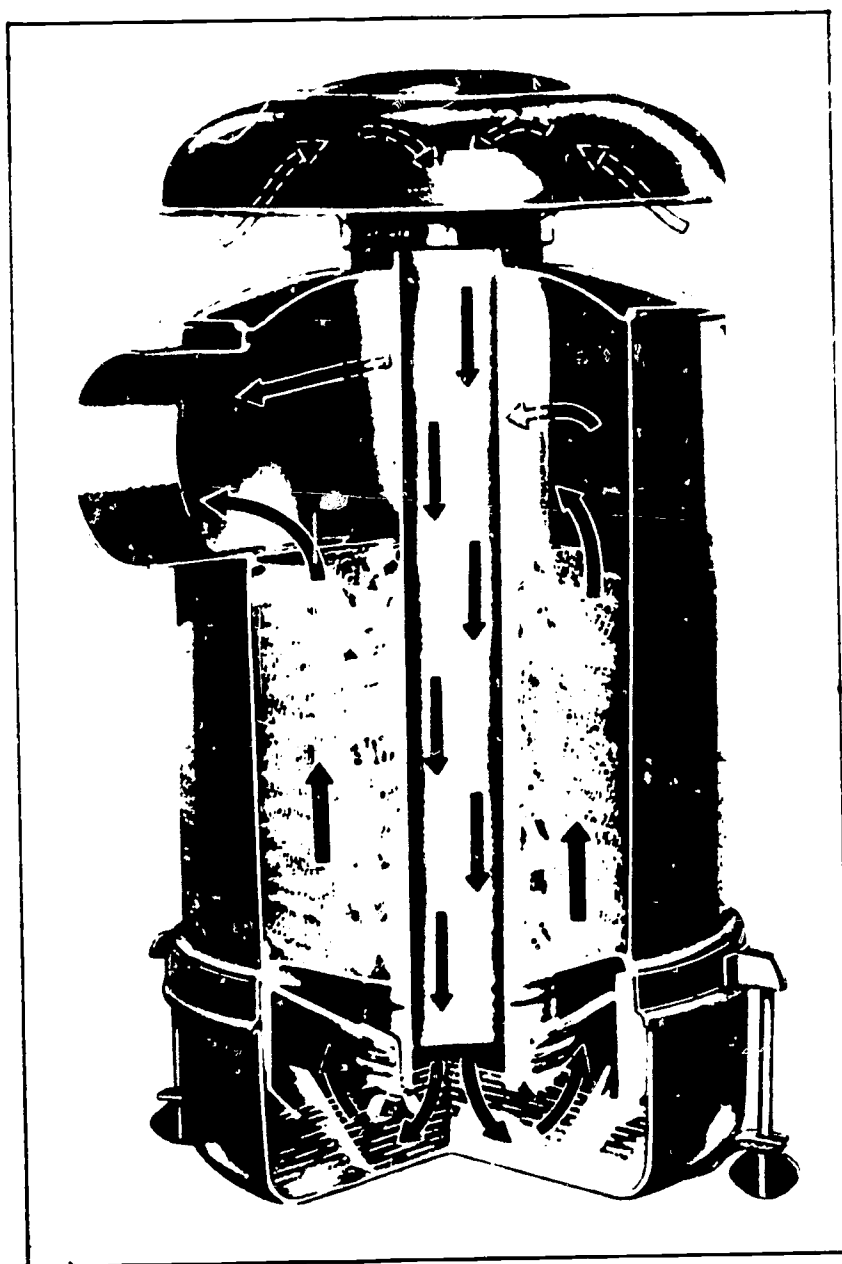

Fig. 3 - Typical Heavy Duty Air Cleaner

air, causing a looping cycle of the oil. However, as the oil is carried toward another cycle, some of the oil will overflow the edge of the cup, carrying the dirt with it. The dirt will be deposited in the outer area surrounding the cup. Oil will then flow back into the cup through a small hole located in the side of the cup. A wire screen element above the separator screen removes any oil which passes through the separator screen. This oil will also drain to the center and back into the oil cup. Clean air leaves the cleaner through a tube at the side, and enters the blower by means of the air inlet housing.

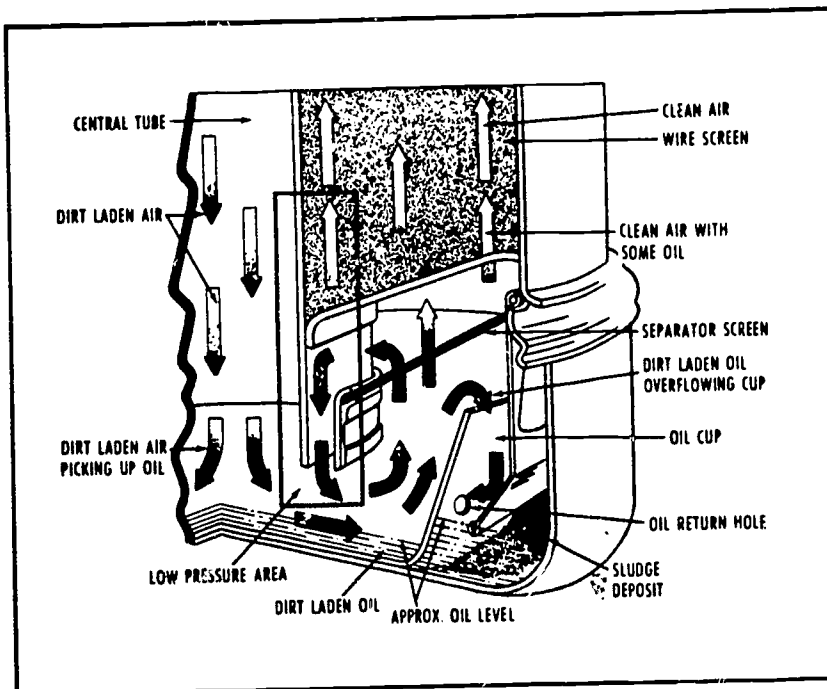

Fig. 4 - Air flow through heavy duty air cleaner.

An air inlet hood serves to prevent rain, rags, paper, leaves, etc. from entering the air cleaner. It is mounted on the air cleaner inlet tube and held in place by a clamp or by the pit of the hood in the inlet tube, depending on the type. Openings in the hood should be kept clear to prevent restriction of air flow. It requires more frequent cleaning than the main air cleaner. Air enters the hood through a heavy screen which forms the lower portion of the hood. The air flow is reversed in the hood and pulled downward into the air cleaner.

Maintenance procedures for an efficient air cleaner operation:

1. Keep air cleaner tight to engine ductwork and piping.
2. Keep air cleaner properly assembled so joints are oiled and air tight.
3. Repair damaged air cleaners, intakes or connections at once.

4. Clean the oil bath cleaners often enough to prevent the oil from becoming excessively thick with sludge. Be sure to use the proper kind and quantity of oil. Keep the oil at level mark in the cup. When replacing cup, be sure it fits snugly to form a tight joint. (In dusty areas, inspect the air cleaner more frequently for dirt deposits in the oil bath.)
5. Where a rubber hose from cleaner to blower is used, remove hose connections and cement them in place. Use a new hose and clamps, if necessary, to obtain an air-tight connection.
6. After servicing the air cleaner, remove the air inlet housing and clean accumulated dirt deposits from blower screen and the housing. Make sure all air intake passages and the air box are kept clean.
7. Check the dust system for loose hose connections or damaged gaskets which permit dust-laden air to by-pass the cleaner and enter the engine directly.
8. In oil bath air cleaners use the same oil as that used in the engine crankcase. The oil level should not be above that indicated on the air cleaner sump. If too much oil is used, it may be pulled through the element and into the engine, thus carrying dirt into the cylinders and also resulting in excessive speed.

SERVICING -- To change the oil, loosen the wing nuts, pull the side rod assemblies away from their forked retaining brackets and remove the oil cup. Empty the cup and clean with fuel oil to remove all sediment.

A tray type screen is used on heavy duty air cleaners. A lip on the tray fits over the edge of the cleaner body to form an air tight seal between the cleaner body and tray. Another seal ring fits around the tray and forms an air and oil seal between the tray and the oil cup.

The efficiency of the tray type oil bath air cleaner will be greatly reduced unless the fibrous material caught in the tray is removed. It is extremely important that the tray be cleaned regularly and properly. If it is plugged with lint or dirt, see Figure 5, wash the tray in a solvent or similar washing.

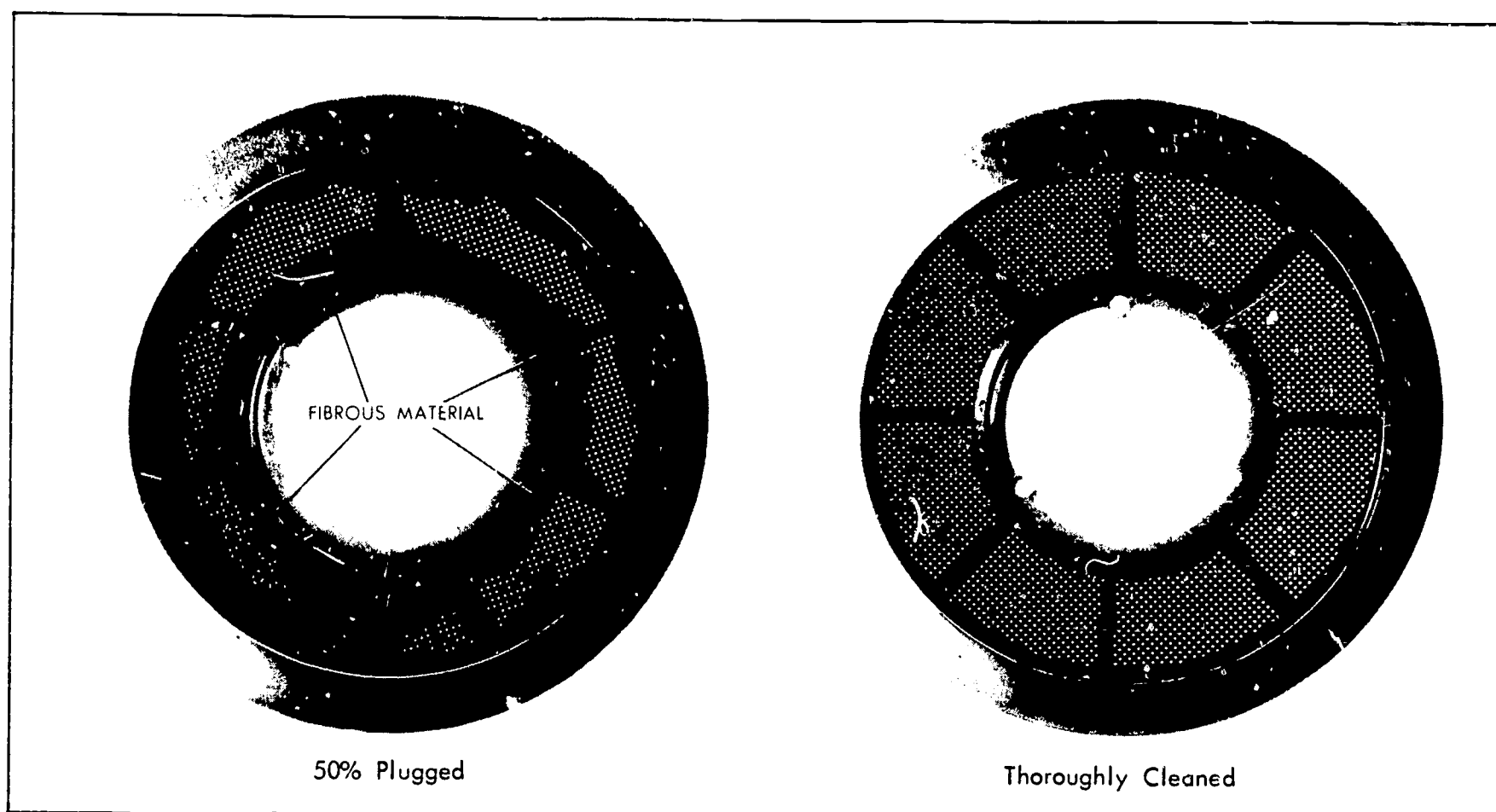

Fig. 5 - Comparison of air cleaner trays.

solution and blow out with high velocity compressed air or steam. An even pattern of light should be visible through the screens when a clean tray is held up to the light, see Figure 5.

Remove the dirt accumulation in the air cleaner center tube by passing a lintless cloth through the tube. Some tubes have a restricted portion at the lower end, and care must be taken not to damage this end.

When all the components have been cleaned, the cleaner is ready for assembly.

The removable screen or tray should be installed. Replace the rubber seal rings if necessary. Fill the cup to the indicated oil level and place on the cleaner. Make certain all gaskets and joints are tight. Check connections from the cleaner to the engine for air leaks.

If unfiltered air is being admitted into the engine through the duct work of an air cleaner installation, use the following procedure for finding the leaks. Note, to make this check, suitable plugs are needed to block the air cleaner system inlet and outlet. The air cleaner inlet plug should contain a suitable air connection and shut-off valve to maintain two pounds pressure in the air duct system. The outlet plug must form a completely air-tight seal at the outlet end of the system.

Check the system as follows:

1. Remove air inlet hood.
2. Insert plug with fitting for air hose into the air cleaner inlet to form an air-tight seal.
3. Insert other plug in to the outlet end of system for air-tight seal.
4. Attach an air hose to inlet plug and regulate pressure not to exceed 2 psi.
5. Brush a soap-suds solution on all air duct connections. Leaks in the connections can be detected by the escaping air causing bubbles in the soap-suds solution. They should all be remedied for an air-tight system.
6. Remove plugs and install air inlet hood.

The air cleaner design is such that the fixed elements tend to be self-cleaning.

At regular periods, however, the entire air cleaner should be removed from the engine and the fixed element cleaned. This can be done by passing a large quantity of clean solvent through the air outlet and down into the fixed element. Allow the cleaned element to dry thoroughly before replacing the cleaner on the engine. Note, if the fixed elements require too frequent cleaning, it is advisable to relocate the air intake for a cleaner air supply.

TWO STAGE DRY TYPE AIR CLEANER -- This cleaner, illustrated in

Figure 6 consists of a primary pre-cleaner in series with a replaceable impregnated paper filter element. There are three types of pre-cleaners:

1. Centrifugal or cyclopath.
2. Cyclone
3. Replaceable paper element.

The dust collected in the centrifugal and cyclone cleaners is exhausted by connecting the dust bin to an exhaust gas aspirator. The pre-cleaner and replaceable filter element are held together in a steel housing. Positive sealing between the two elements and the housing is provided by rubber gaskets. The steel housing incorporates filter fasteners, mounting flanges, and an outlet for the filtered air.

OPERATION -- Air enters the pre-cleaner where 90% of the dirt is removed by the centrifuge, cyclones or the primary paper element. The air then enters the center opening of the paper element where the remaining dirt impinges on the paper. In all types of dry air cleaners, high cleaning efficiency is maintained at all engine speeds. Oil bath air cleaners are not efficient at low speed or at idle.

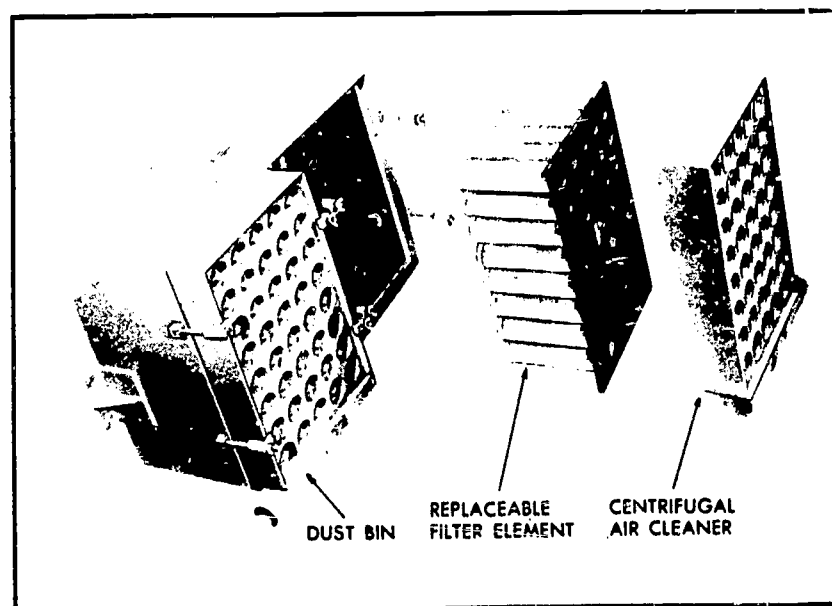

Fig. 6 - Dry type air cleaner

SERVICING -- An air cleaner restriction indicator, shown in Figure 7, may be attached near the outlet side of the cleaner. As the restriction in the cleaner increases, suction will pull the indicator plunger upward. A brightly colored card attached to the plunger and visible through a small window in the indicator, will indicate the relative amount of air restriction in the cleaner. When the card is fully visible, the air cleaner should be cleaned and the indicator reset by pushing the plunger all the way up and then releasing it.

A water manometer, however, is the most positive means of determining the restriction in the cleaner. This should not exceed 16" of water. The air restriction should be checked at each servicing.

When servicing the dry type air cleaner, remove and clean the dust pan. If the paper element requires replacing because of excessive air restriction, the cyclones or direction vanes should be blown out with compressed air with the dirty secondary element in place. After the element

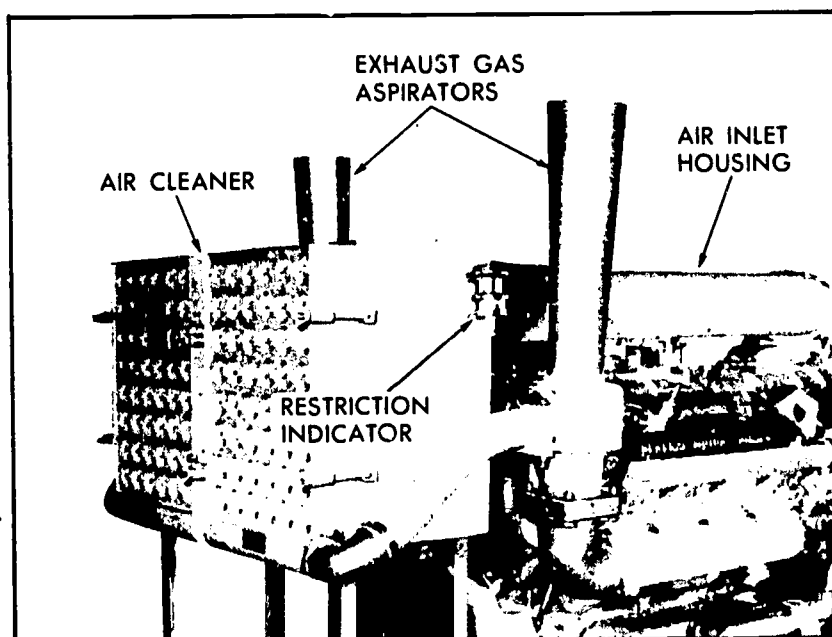

Fig. 7 - Typical dry type air cleaner mounting.

is removed, the upper body should be wiped clean. Inspect the sealing surfaces for dents before installing the new element. If the surfaces are dented, do not use the element. Replace gaskets and install a new or cleaned element. Note, a second air restriction check should be made after cleaning or replacing the paper element.

SECTION C -- AIR SHUT-DOWN HOUSING

Air flows from the cleaners through an air inlet housing, an air shut-down housing, air inlet manifold (or adaptor), the blower, and then into the engine air box and cylinders. The air shut-down housing contains a valve that shuts off the air supply and stops the engine whenever abnormal operating conditions require an emergency shutdown. (See Figure 8).

INSPECTION AND SERVICING -- When the air shut-down housing has been removed from the engine, check the interior condition of the air inlet housing. Clean the air shut-down housing and blower screen with fuel oil and dry with compressed air. Check to make sure that no foreign materials (tools, rags,

etc.) are in the inlet or in the shut-down housing, or the blower. Always use a new gasket between the air inlet housing and the air shut-down housing.

When the air shut-down housing has been installed, check the operation of the shut-down valve. Make sure it operates freely and is not restricted or bound-up. Make a final check to see if all bolts and hose clamps are secure for air-tight connections. On V-16 engines, two air shut-down housings are used. Make sure the connecting linkage is adjusted to shut-down engines at the same time.

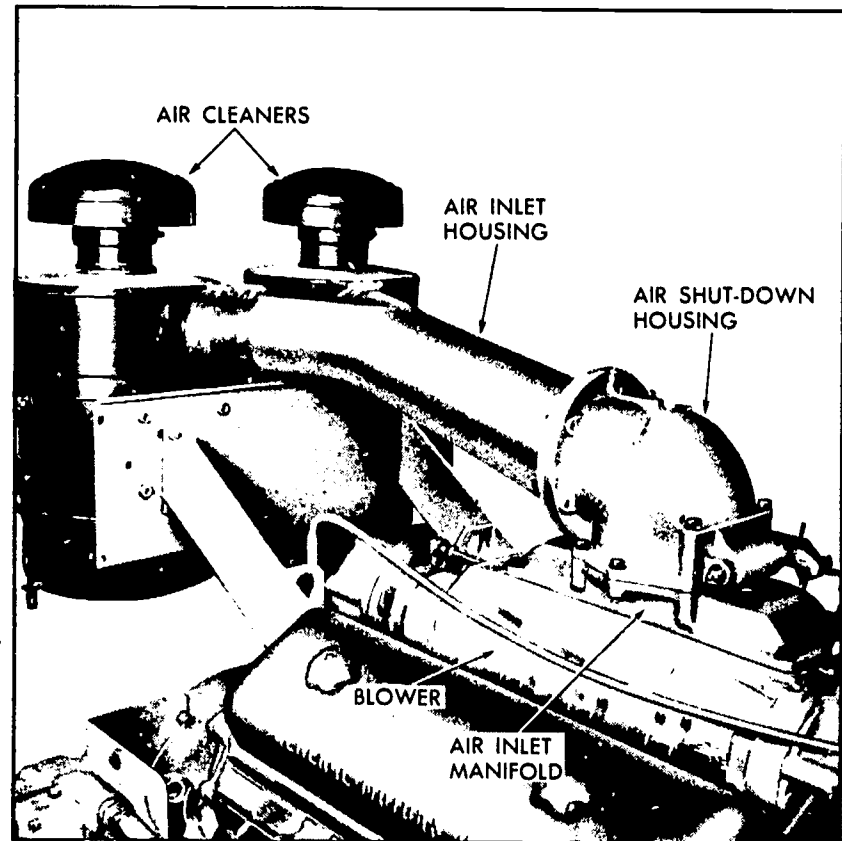

Fig. 8 - Typical air shut-down housing mounting.

SECTION D -- EXHAUST SYSTEM

The removal of burnt, hot gases, which exist after combustion, is just as important as supplying clean fresh air to the engine for combustion and cooling. Burnt gases are removed through the exhaust valves at the top of the cylinder. When the piston is near the end of its downward stroke, it uncovers the air inlet ports. Cooler, heavier air comes into the cylinder and aids in forcing the hot gases out the exhaust valves. This process is called scavenging. The word scavenging means to "cleanse". The cooler air "cleans" the cylinder of hot gases.

The air-cooled exhaust manifold, see Figure 9, is mounted on the cylinder head. For all practical purposes, the manifold, or in the case of the V-71 series -- two manifolds, is nothing more than a channeling device or passage

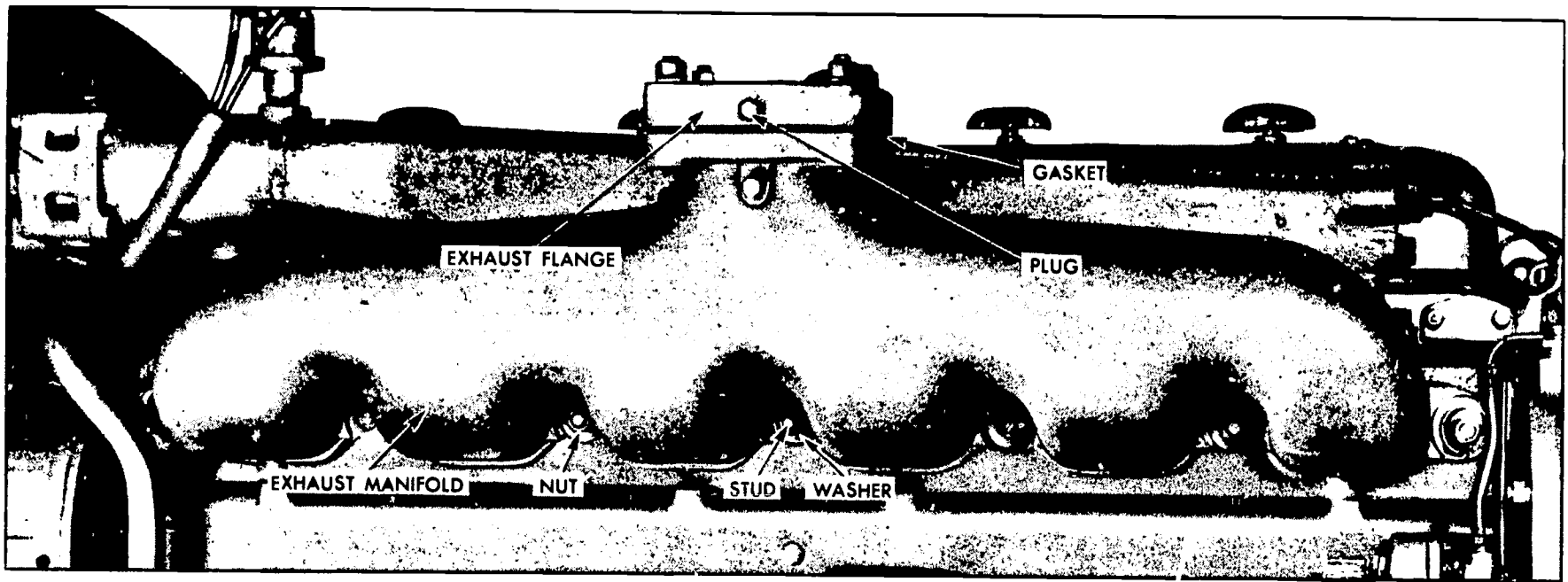

Fig 9 - Exhaust manifold.

way which routes the burnt gases from the cylinders via the manifold pipe, muffler and exhaust stack into the outside air.

EXHAUST BACK PRESSURE -- A slight pressure in the exhaust system is normal. However, excessive exhaust back pressure seriously affects engine operation. It may cause an increase in the air box pressure with a resultant loss of efficiency of the blower. This means less air for scavenging and results in poor combustion and higher temperatures.

High exhaust pressure can be caused by an improper type of muffler, an exhaust stack which is too long or too small in diameter, too many sharp bends in the exhaust system, or obstructions such as excessive carbon formation or foreign matter in the exhaust system

MAINTENANCE AND INSPECTION -- The interior of the manifold should be checked for foreign material that could cause exhaust restriction. Remove the loose scale and carbon that accumulates on the internal walls of the manifold. (It is particularly important to clean the manifold used on turbocharged units to eliminate the possibility of loose scale entering and damaging the turbocharger). Examine the exhaust manifold studs for damage. When the manifold has been removed from the engine, new gaskets should be used when replacing the units.

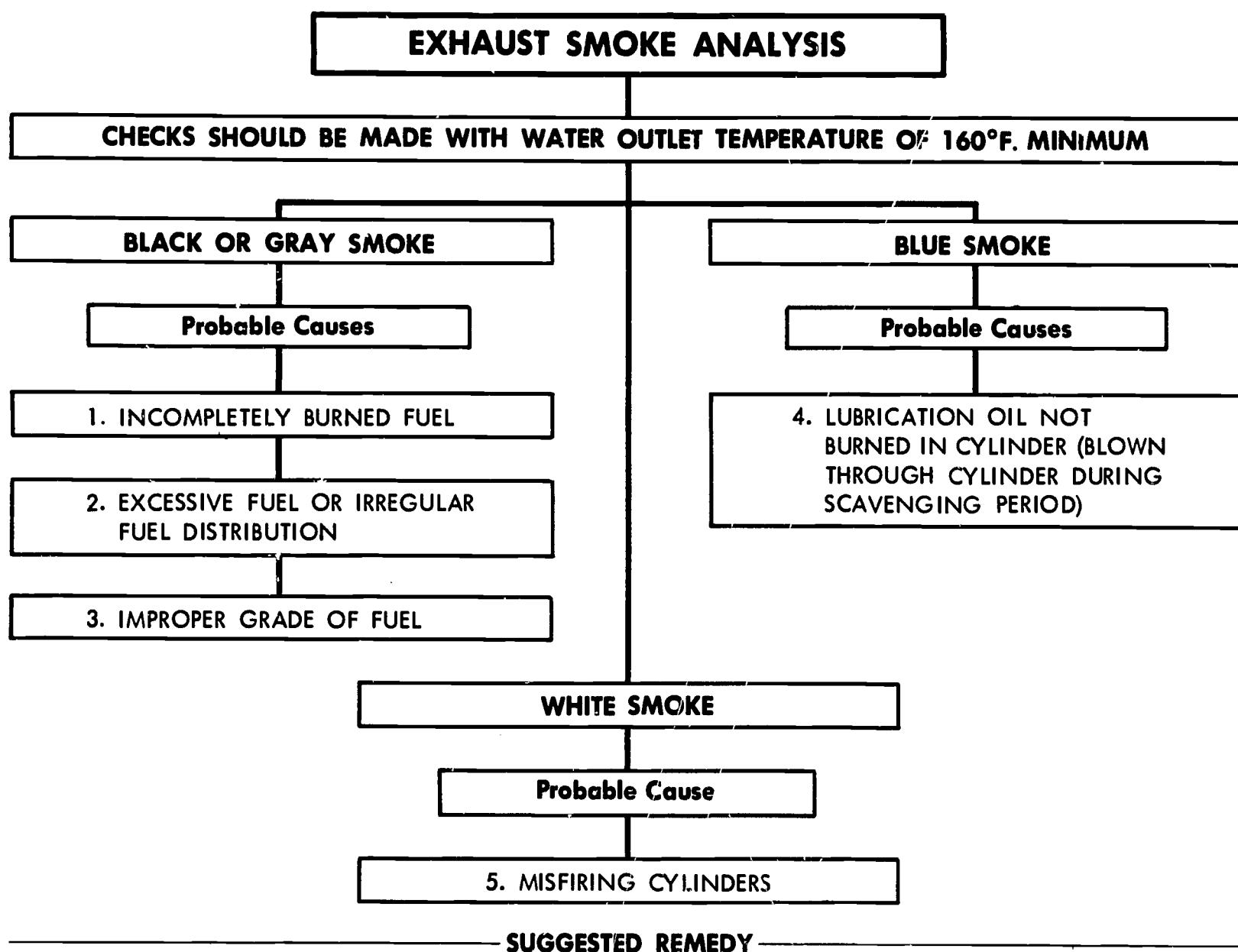

1. High exhaust back pressure or a restricted air inlet causes insufficient air for combustion and will result in incompletely burned fuel.

High exhaust back pressure is caused by faulty exhaust piping or muffler obstruction and is measured at the exhaust manifold outlet with a manometer. Parts causing high exhaust back pressure should be replaced.

Restricted air inlet to the engine cylinders is caused by clogged cylinder liner ports, air cleaner, or blower to air inlet screen. These items should be cleaned. Check the emergency stop to see that it is completely open and readjust it if necessary.

2. Check for improperly timed injectors and improperly positioned injector rack control levers. Time the fuel injectors as outlined in "Fuel Injector Timing" and perform the appropriate governor tune-up to correct this condition.

Replace faulty injectors if this condition still persists after timing the injectors and performing the engine tune-up.

Lugging the engine will cause incomplete combustion and should be avoided. Operate the unit as outlined in "Engine Operation."

3. Check for the use of an improper grade of fuel. Consult the "Fuel Oil Specifications" for the correct fuel to use.
4. Check for internal lubricating oil leaks, and refer to the "High Lubricating Oil Consumption" chart.
5. Check for faulty injectors and replace as necessary.

Check for low compression and consult the "Hard Starting" chart.

The use of low cetane fuel will cause this condition and can be corrected by consulting and following the "Fuel Oil Specifications".

SECTION E -- THE BLOWER

The Roots blower supplies fresh air for combustion and scavenging. Its operation is similar to that of a gear-type oil pump. Two hollow three-lobe rotors revolve with very close clearances in a housing bolted to the cylinder block. The rotor lobes are made in a helical (spiral) form to provide continuous and uniform displacement of air, see Figure 10.

Two timing gears, located on the drive end of the rotor shafts, space the rotor lobes with a close tolerance. The lobes of the two rotors do not touch at any time, so no lubrication is required. The build-up of oil and carbon deposits on the rotor lobes actually improves the sealing clearance and tends to increase the air flow.

Lip type oil seals, located in the blower end plates, prevent air leakage. They also keep the oil, used for lubricating the timing gears and rotor shaft bearings, from entering the rotor compartment.

Each rotor is supported in the doweled end plates of the blower housing by a roller bearing at the front end and a two row pre-loaded radial and thrust ball bearing at the gear end.

The blower is driven by the main gear train of the engine. The drive gear is connected directly to the camshaft gear. Because the blower drive gear has fewer gear teeth, it rotates much faster than the engine. Only one lobe is driven directly by the gear train. This lobe in turn drives the other lobe by means of a timing gear.

The basic blower parts for the 6 and 8 cylinder engines are identical and interchangeable with the exception of the housing and rotors which differ in length. Two 6V blowers, coupled together by means of a sprocket and chain drive, are mounted in tandem on the top deck of the 12-cylinder engine models. Two 8V blowers are mounted in a similar manner for 16-cylinder engine models.

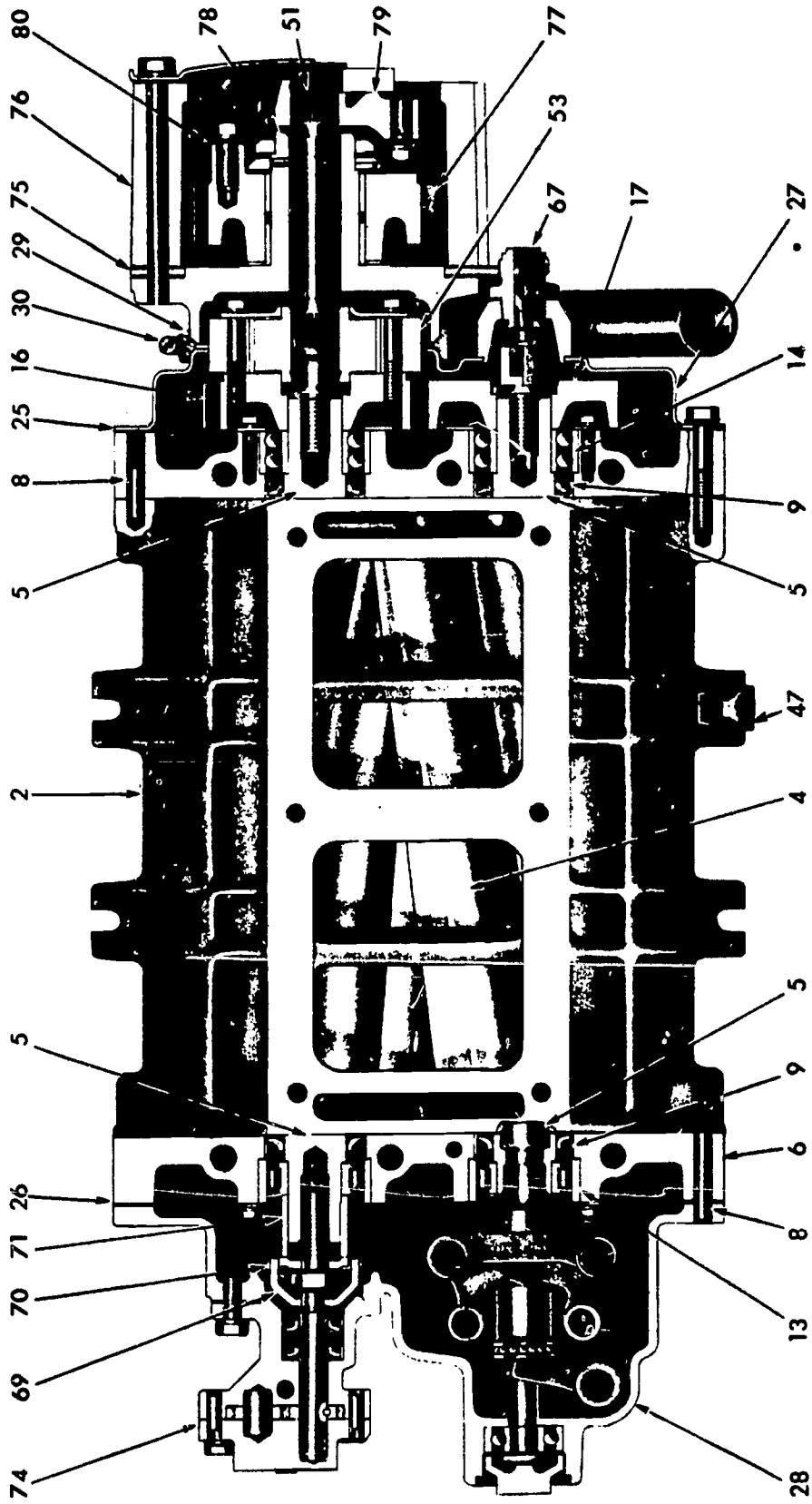

- | | | | |
|-----------------------------|---|---------------------------------------|---|
| 74. Housing--Blower | 25. Gasket--Rear End | 47. Lug--Mounting Bolt | 74. Pump Assy.--Fuel |
| 4. Rotor Assy.--Blower | 26. Plate Cover | 51. Shaft--Blower Drive | 75. Plate--Rear Cylinder Block End |
| 3. Shaft--Rotor | 27. Gasket--Front End | 53. Coupling Assy.--Blower Drive | 76. Housing--Flywheel |
| 6. Plate--Blower End | 28. Cover--Rear End Plate | 67. Fitting--Tachometer Drive Adaptor | 77. Gear--Blower Drive |
| 8. Pin--Dowel | 29. Housing--Governor (Front End Plate Cover) | 69. Fork--Fuel Pump Drive | 78. Support--Blower Drive |
| 9. Seal--Oil | 30. Seal--Rear End Plate Cover | 70. Disc--Fuel Pump Drive | 79. Coupling--Blower Drive Flexible |
| 13. Bearing--Front (Roller) | 31. Cover | 71. Spacer--Fuel Pump Drive Disc | 80. Plate--Blower Drive Flexible Coupling |
| 14. Bearing--Rear (Ball) | 32. Clamp--Rear End Plate Cover Seal | | |
| 16. Gear--Rotor Drive | | | |
| 17. Gear--Rotor Driven | | | |

Fig. 10 - Blower and drive assembly and accessories attached to blower.

The blower rotors are timed by the two rotor gears at the rear end of the rotor shafts. This timing must be correct. Otherwise, the required clearance between the rotor lobes will not be maintained.

Normal gear wear causes a decrease of rotor-to-rotor clearance between the leading edge of the right-hand helix (drive) rotor and the trailing edge of the left-hand helix (driven) rotor. Clearance between the opposite sides of the rotor lobes is increased correspondingly.

While the rotor lobe clearance may be corrected by adjustment, gear backlash cannot be corrected. When gears have worn to the point where the backlash exceeds .004", the gears should be replaced.

Because of the important part the blower plays in the efficient operation of these diesel engines, an inspection of the unit should be made at 1000 hour intervals of engine operation. If this practice is followed, minor irregularities can be detected and corrected before major problems develop.

INSPECTION AND MAINTENANCE -- The blower may be inspected for the following conditions without being removed from the engine. However, the air inlet housing, air shut-down housing and adaptor must be removed first.

CAUTION: When inspecting a blower when the engine is running, keep fingers and clothing away from the moving parts of the blower and run the engine at low speeds only.

Dirt or chips, drawn through the blower, will make deep scratches in the rotors and housing and throw up burrs around such abrasions. If the burrs cause interference between rotors or between rotors and housing, the blower should be removed and the parts dressed down or replaced if badly scored.

LEAKY OIL SEALS are usually indicated by oil on the blower rotors or inside surfaces of the housing. This can be checked by running the engine at low speed and directing a light into the rotor compartment at the end plates and oil seals. A thin film of oil radiating from the seals is an indication of an oil leak.

WORN BLOWER DRIVE, resulting in a rattling noise inside the blower, may be detected by grasping the right-hand helix rotor firmly and attempting to rotate it. Rotors may move from 3/8" to 5/8", measured at the lobe crown, with a springing action. When released, the rotors should move back at least 1/4". If the rotors cannot be moved as directed above, or if they move too freely, the flexible rotor blower drive coupling should be inspected and replaced if necessary. The drive coupling is attached to the right-hand helix blower timing gear.

LOOSE ROTOR SHAFTS OR DAMAGED BEARINGS. A loose shaft usually causes rubbing between rotors and end plates. Worn or damaged bearings will cause rubbing between mating rotor lobes at some point or perhaps allow the rotor assemblies to rub the blower housing. This condition will usually show up at the end where the bearings have failed. Generally a combination of the above conditions exist.

EXCESSIVE BACKLASH in blower timing gears usually results in rotor lobes rubbing throughout their entire length.

THE BLOWER INLET SCREEN should be inspected periodically for the accumulation of dirt which may affect the air flow. Servicing the screen consists of a thorough washing in fuel oil and cleaning with a stiff brush until the screen is free of all dirt deposits.

CLEANING AND ADJUSTING BLOWER -- When the blower has been disassembled, wash all parts thoroughly in clean fuel oil, blow dry with compressed air, and inspect as follows:

1. Races and balls or rollers of bearings should be examined for indications of corrosion or pitting. Apply light engine oil to bearings; then, while holding inner race from turning, revolve the outer race slowly by hand to check for free rolling of the balls or rollers on the races. Rough spots in the bearings are sufficient cause for rejection.

The double row ball bearings are pre-loaded and have no end play.

A new double row bearing will seem to have considerable resistance to motion when revolved by hand.

2. Inspect the lip type oil seals for scoring, charring or hardening. When a blower is being reconditioned, the installation of new oil seals is recommended.
3. Rotors must be smooth for efficient operation of blower. If slightly scored or burred, rotor may be dressed down with emery cloth. Replace badly scored rotors.
4. Inspect rotor shaft serrations and bearing surfaces for wear or burrs. If worn badly, replace rotors.
5. The inside of housing must be smooth for efficient operation of blower. If slightly scored or burred, it may be cleaned up with emery cloth. Replace badly scored housing.
6. The finished inside of end plates must be smooth and flat. If a finished face is slightly scored, clean up with emery cloth; however, if face is badly scored, replace end plate.
7. Check blower timing gears for wear or damage. If either gear is worn or damaged sufficiently to require replacement, both gears must be replaced as a set. When gears have worn to the point where the backlash exceeds .004", the gears should be replaced.
8. Check the blower drive shaft for straightness and serrations for wear. If shaft is bent or serrations are worn badly, it must be replaced.
9. Inspect the blower drive coupling springs (pack) and the cam to see that springs are in tact and cam is not worn.
10. Make sure oil holes are open and cavities are free from dirt.
11. Check the serrations in the blower timing gears. If serrations are worn, replace gears.

Timing the Blower Rotors -- The blower rotors, when properly positioned in the housing, run with a slight clearance between the lobes. This clearance may be varied by moving one of the helical gears in or out on the shaft relative to the other gear. If the right-hand helix gear is moved out, the right-hand helix rotor will turn counterclockwise when viewed from the gear end. If the left-hand helix gear is moved out, the left-hand helix rotor will turn clockwise when viewed from the gear end. This positioning of the gear, to obtain the proper clearance between the rotor lobes, is known as blower timing.

Moving the gears OUT or IN on the rotors is accomplished by adding or removing shims between the gear hub and the bearing. The clearance between rotor lobes may be checked with various thickness feeler ribbons 1/2" wide in the manner shown in Figure 11. When measuring clearance of more than .005", laminated feelers that are made up of .002", .003" or .005" feeler stock are more practical and suitable than one thick feeler gauge. Clearances should be measured from both the inlet and outlet sides of the blower.

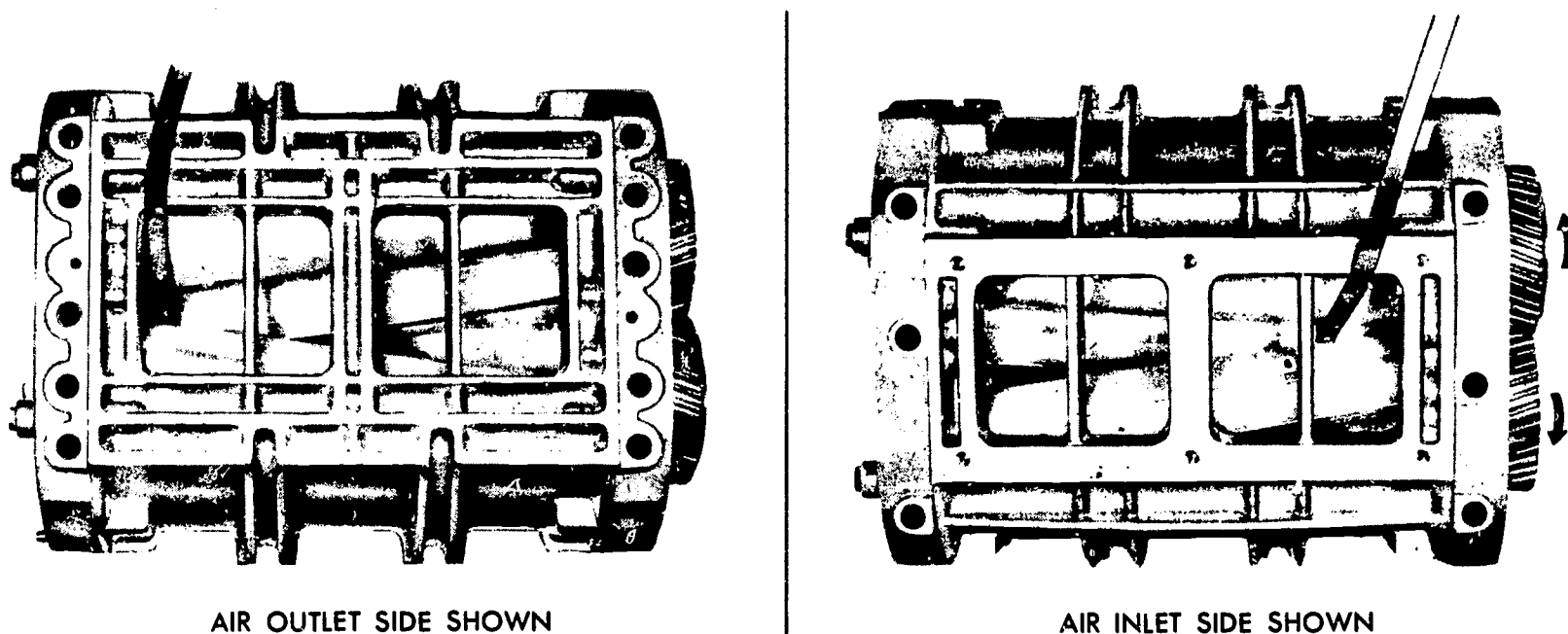

Fig. 11 - Measuring "CC" and "C" clearance between blower rotor lobes.

A specially designed feeler gauge set J 1698-02 for the blower clearance operation is available. Time rotors to have from .002" to .006" clearance between the trailing edge of the right-hand helix rotor and the leading edge of the left-hand helix rotor ("CC" clearance) measured from both the inlet and outlet sides as shown in Figures 11 and 12. If possible, keep this clearance between leading edge of right-hand helix rotor and trailing edge of left-hand helix rotor ("C" clearance) for the minimum clearance of .012". Rotor-to-rotor measurements should be taken 1" from each end and at center of blower.

Having determined the amount one rotor must be revolved to obtain the proper clearance, add shims back of proper gear, as shown in Figure 13, to produce the desired result. When more or fewer shims are required, both gears must be removed from the rotors.

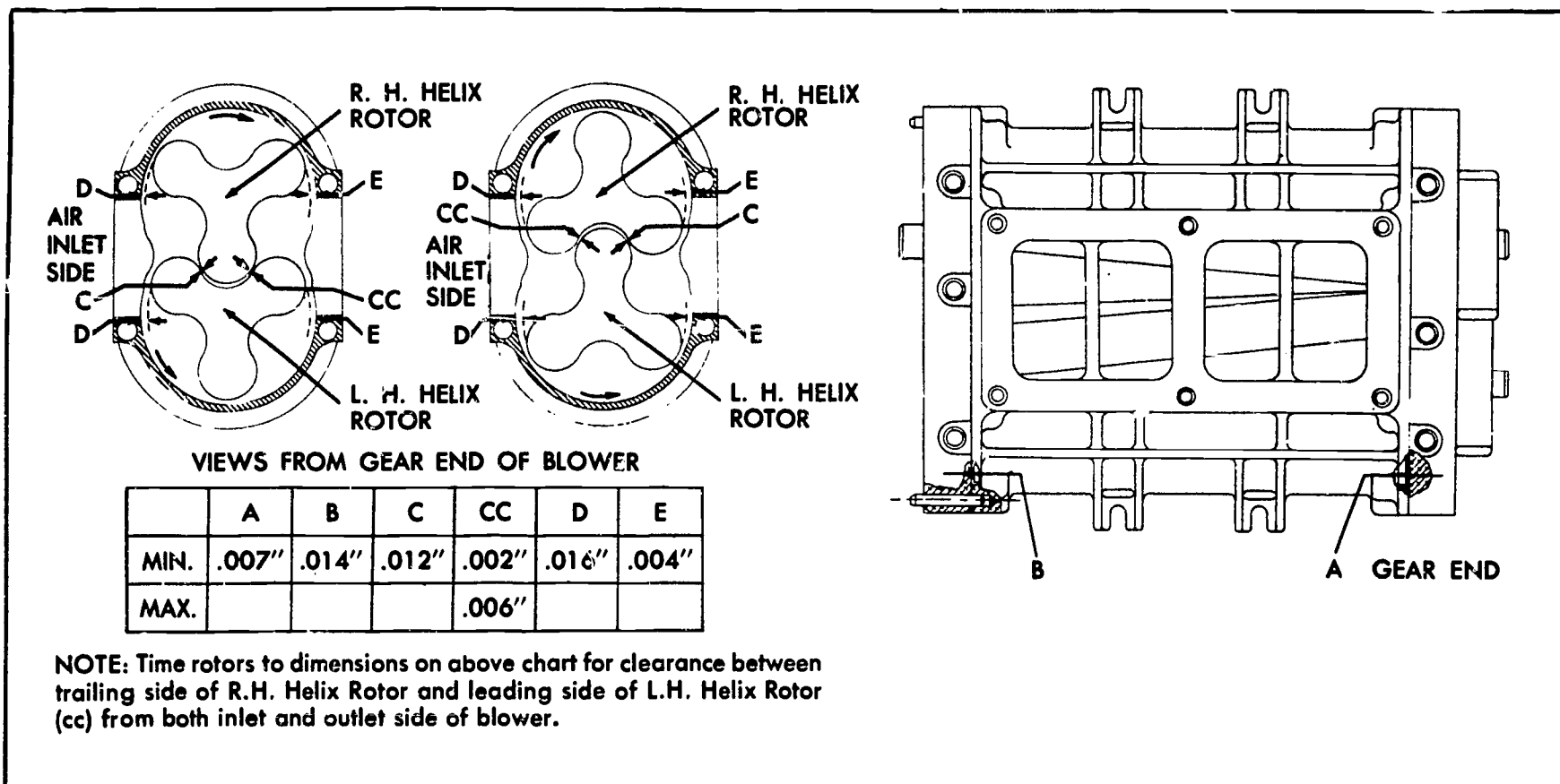

Fig. 12 - Chart of Minimum Blower Clearances

Placing a .003" shim in back of a rotor gear will revolve the rotor .001". Install the required thickness of shims back of the proper gear and next to the bearing inner race and re-install both gears. Recheck clearances between rotor lobes.

Determine minimum clearances at points "A" and "B" shown in Figure 12. Insert feelers, between end plates and ends of rotors. This operation must be performed at the ends of each lobe, making 12 measurements in all. See Figure 12 for minimum clearances.

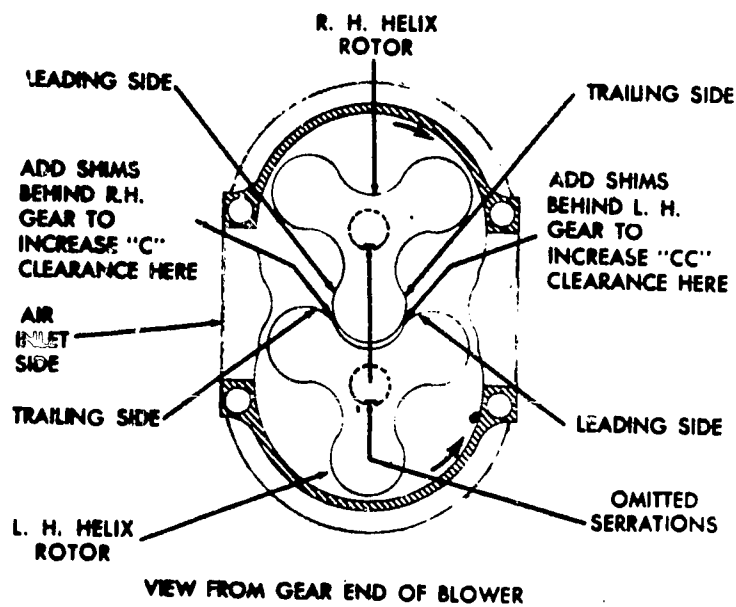

Fig. 13 - Diagram showing proper location of shims for correct rotor lobe clearances.

SECTION F -- THE TURBOCHARGER

The turbocharger is designed to increase the power output and improve the efficiency of an engine. Power to drive the turbocharger is extracted from

waste energy in the engine exhaust gas. The turbocharger consists of a radial inward flow turbine; a centrifugal compressor; a bearing carrier, which serves to support the rotating assembly; main housing; a turbine housing; and a compressor housing, see Figure 14.

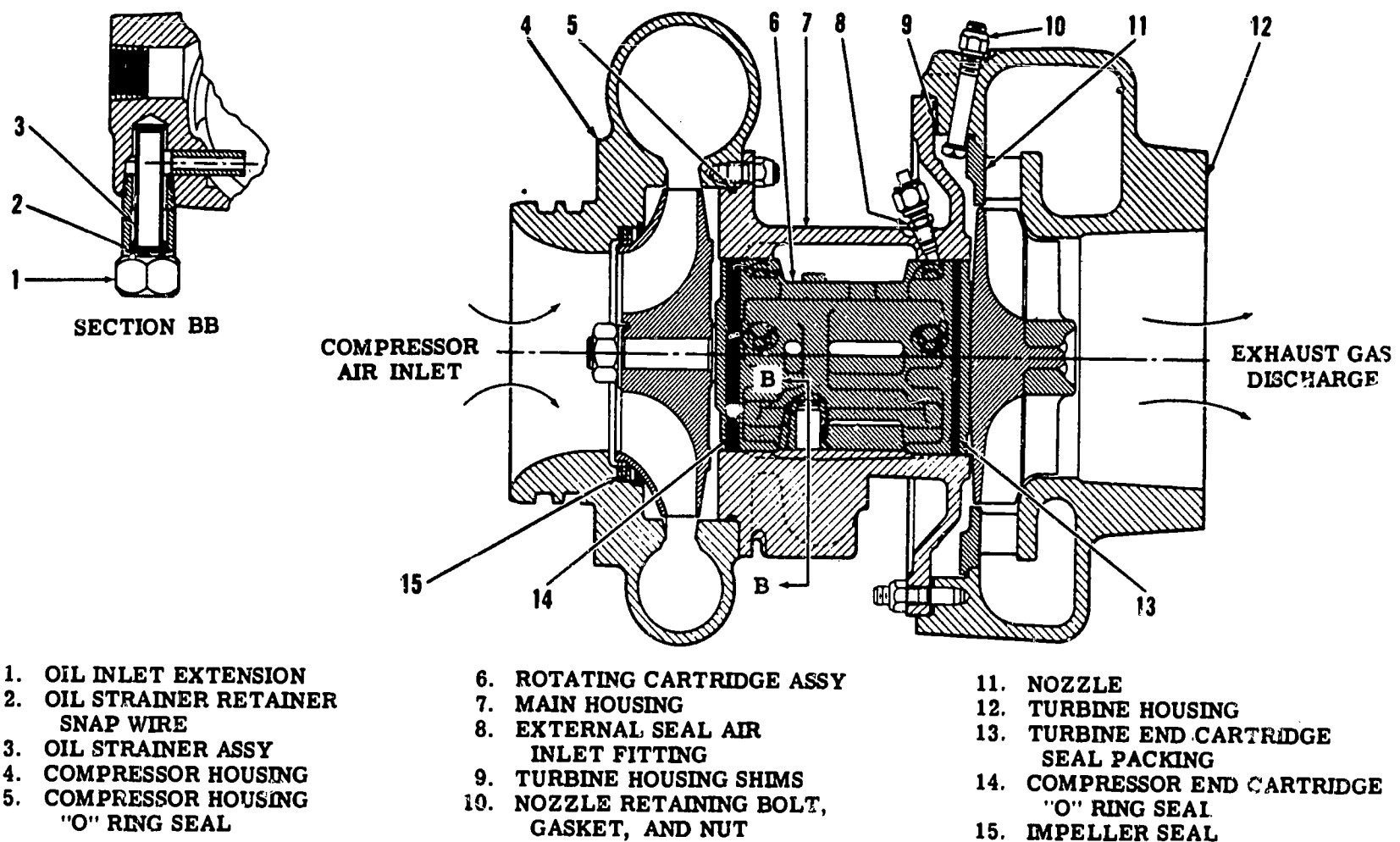

Fig. 14 - Typical Turbocharger

The turbine wheel is located in turbine housing (12) and is mounted on one end of the shaft. The impeller is located in compressor housing (4), and is mounted on the other end of the shaft to form an integral rotating assembly. To assure freedom from vibration, the entire rotating assembly has been dynamically balanced during manufacture and assembly.

The rotating assembly is supported by two pressure-lubricated bearings housed in a bearing carrier. Engine oil is supplied to the bearings, through internal passages bored in the carrier, to lubricate the bearings and to aid in the removal of excessive heat.

Main housing (7) encloses and supports the bearing carrier, and provides the lubricating oil inlet and outlet connections. The main housing also serves to mount turbine housing (12) and compressor housing (4). The main housing is made in two sections to facilitate removal and replacement of rotating cartridge assembly (6). Cartridge packings (13 and 14) mounted on the rotating cartridge assembly, one each located behind the turbine wheel and the compressor impeller, prevent lubricating oil from entering the turbine or compressor.

Turbine housing (12) is a heat resistant alloy casting which encloses the turbine wheel and provides a flanged engine exhaust gas inlet, and an axially-located turbocharger exhaust gas outlet. A thermocouple boss in the turbine housing provides for measuring the exhaust gas temperature if desired. The turbine housing is bolted to main housing (7), providing a compact and vibration-free assembly.

Turbine nozzle (11) directs the exhaust gas against the turbine wheel. It is positioned against a shoulder in the turbine housing, and is retained by three bolts through the turbine housing. Angular orientation of the turbine housing may be obtained in increments of 22.5 degrees, to accommodate various engine installations.

Shims (9) are used between main housing (7) and turbine housing (12) to control clearance between the turbine wheel and the turbine housing.

Compressor housing (4) bolts directly to main housing (7), and encloses the compressor impeller. A replaceable impeller seal (15) is located at the inlet end of the compressor housing. The impeller seal consists of a wave washer, three spacers, and three glands. The parts forming the impeller seal are held in position by a snap ring. Angular orientation of the compressor housing may be obtained in increments of 15 degrees, to accommodate various engine installations.

Lubricating oil for the turbocharger is supplied directly from the engine lubricating system. Oil flows through the internally bored passages to each bearing of rotating cartridge assembly (6). Discharge oil drains by gravity.

OPERATION- -The turbocharger is mounted on the exhaust outlet of the engine exhaust manifold. All exhaust gases from the engine pass through the turbine end of the turbocharger before they are discharged into the atmosphere. After the engine is started, the flow of the exhaust gases will begin operating the turbocharger. During operation, the turbocharger responds to the engine load demands by reacting to the flow of exhaust gases and the corresponding air demand of the engine. See Figure 15.

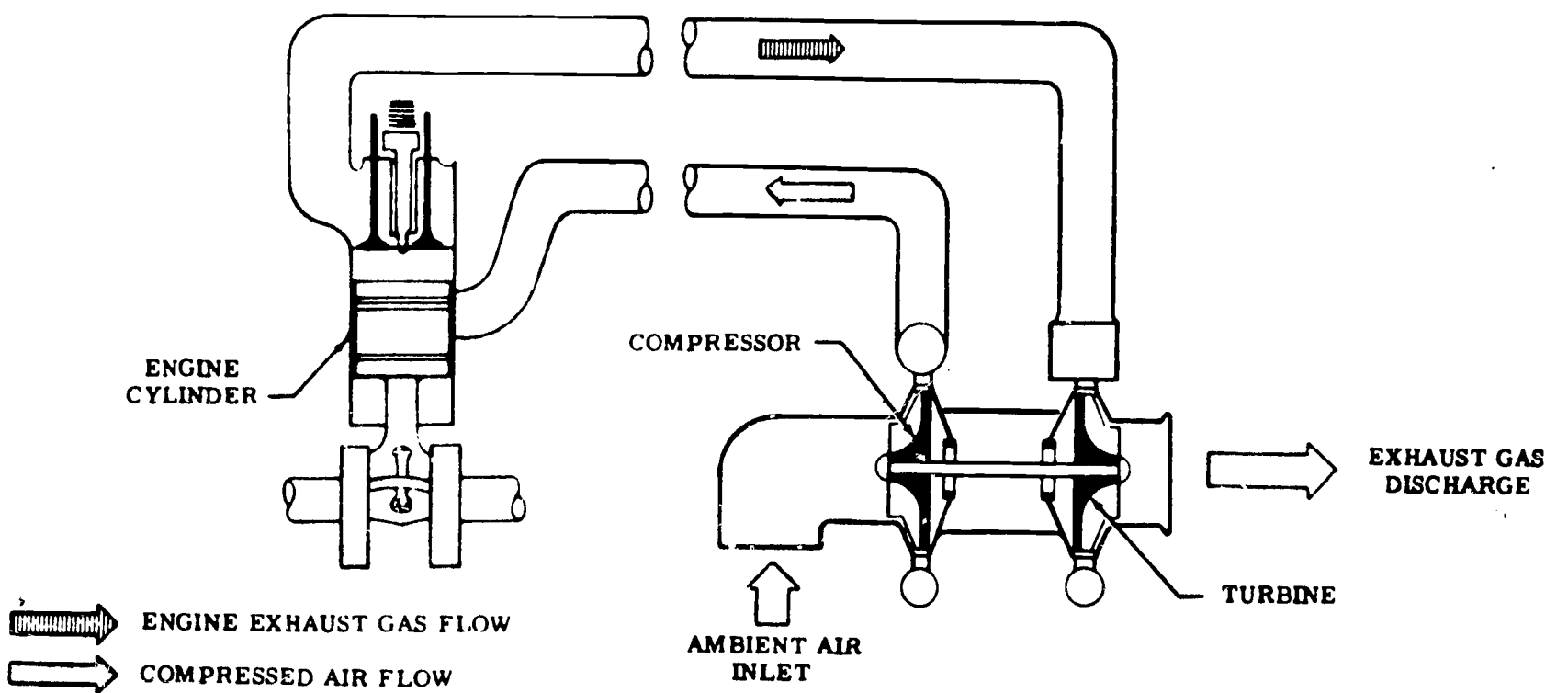
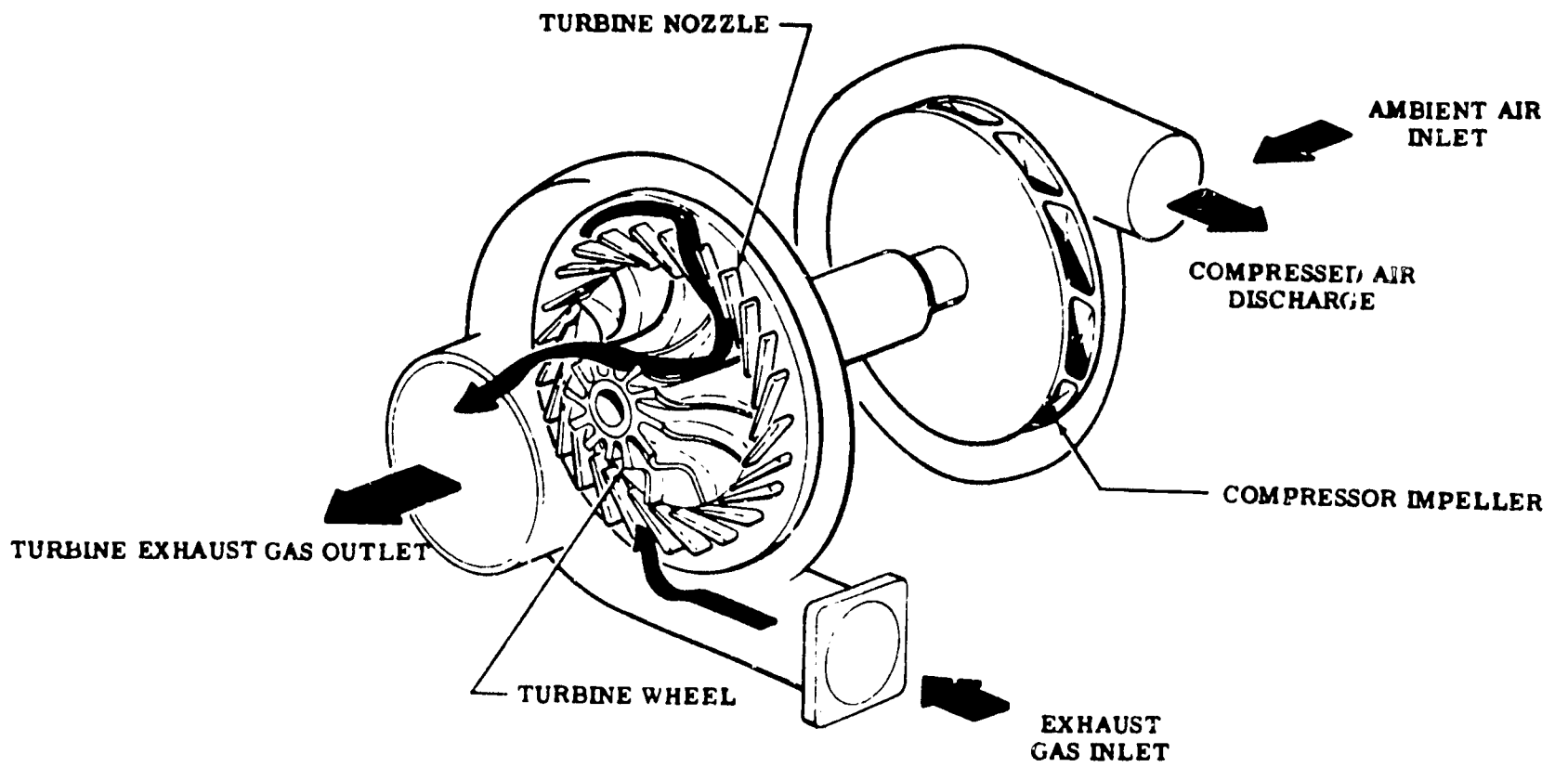

Fig. 15 - Schematic Flow Diagram

The compressor impeller of the turbocharger is directly connected to the turbine which is driven by the engine exhaust gases. These hot exhaust gases expand through the turbine nozzle, and the turbine wheel, thus producing torque and power to drive the compressor. Intake air enters the compressor housing, flows through the impeller, is compressed and supplied to the inlet manifold of the engine.

The turbocharger responds to the engine load demands without control connections between the engine and the turbocharger. Regulation of the turbocharger is automatic, and is accomplished without any special couplings, gear or valves.

Servicing and Maintaining the Turbocharger -- the following points should be checked frequently to maintain top operating performance:

1. Inspect the mounting and the connections of the turbocharger to be certain they are secure, and that there is no lubricant or duct leakage.
2. Check the engine crankcase breather to make sure that there are no restrictions to air flow.
3. Operate the engine at the approximate rated output, and listen for unusual turbocharger noises. If a shrill, high pitch whine is heard, shut down the engine immediately. The whine is indicative of bearing failure. Remove the turbocharger for overhaul. (Do not confuse the whine heard during run down with that which indicates a bearing failure during operation). Other noises can result from improper clearance between the turbine wheel and the turbine housing. If such noises are heard, the turbocharger must be removed from the engine, disassembled and inspected.
4. Check the turbocharger for unusual vibrations while the engine is operating at the approximate rated output. If excessive vibration is evident, remove the turbocharger for disassembly and inspection.
5. Check the engine under loaded conditions. Excessive exhaust smoke indicates improper fuel-air mixture, and could be a result of either engine overloading or turbocharger malfunction.
6. Inspect and service the engine air cleaner in accordance with the instructions of its manufacturer.

PERIODIC INSPECTION -- In addition to the inspection, make the following check of the turbocharger when making a regular engine inspection.

1. Inspect all air ducting connections for possible leaks with the engine shut down, and with the engine running. Repeat this inspection at manifold connections to turbine inlet and engine exhaust manifold gasket.

CAUTION: Do not operate the turbocharger if a leak exists in the ducting, or if the air cleaner is not filtering efficiently. Dust leaking into the air ducting can damage the turbocharger and the engine.

2. Remove the air inlet duct and check the compressor impeller for dirt build-up. Dirt build-up must be removed. See Figure 16. Remove the turbocharger from the engine, disassemble, and clean.

NOTE: If excessive dirt build-up is noted on the compressor impeller, determine and correct cause of dirt entering the turbocharger. Check all air ducting and the air cleaner. However, before removing the turbocharger from the engine remove as much dirt as possible from the exterior surfaces. After removing turbocharger and before disassembly, again clean dirt from the exterior surfaces.

3. With the inlet duct removed, turn the rotating cartridge assembly by hand, and check for binding or rubbing. Listen carefully for unusual noises. If binding or rubbing is evident, remove the turbocharger for disassembly and inspection.

BEARING CLEARANCE INSPECTION -- This determines whether or not it is necessary to replace rotating cartridge assembly (31), shown in Figure 17. Prior to checking the bearing clearance, it is necessary to remove the air inlet exhaust discharge ducting from the turbocharger.

1. Fasten a dial indicator on turbine housing (11) with indicator registered on smallest diameter of turbine wheel hub.
2. Place thumb on impeller nut and push down.
3. Move turbine wheel up and down while pushing down on the impeller nut.
4. Read dial indicator while moving turbine wheel as noted in Step 3 above.
5. Fasten a dial indicator on compressor housing (3) while indicator registered on compressor impeller nut.

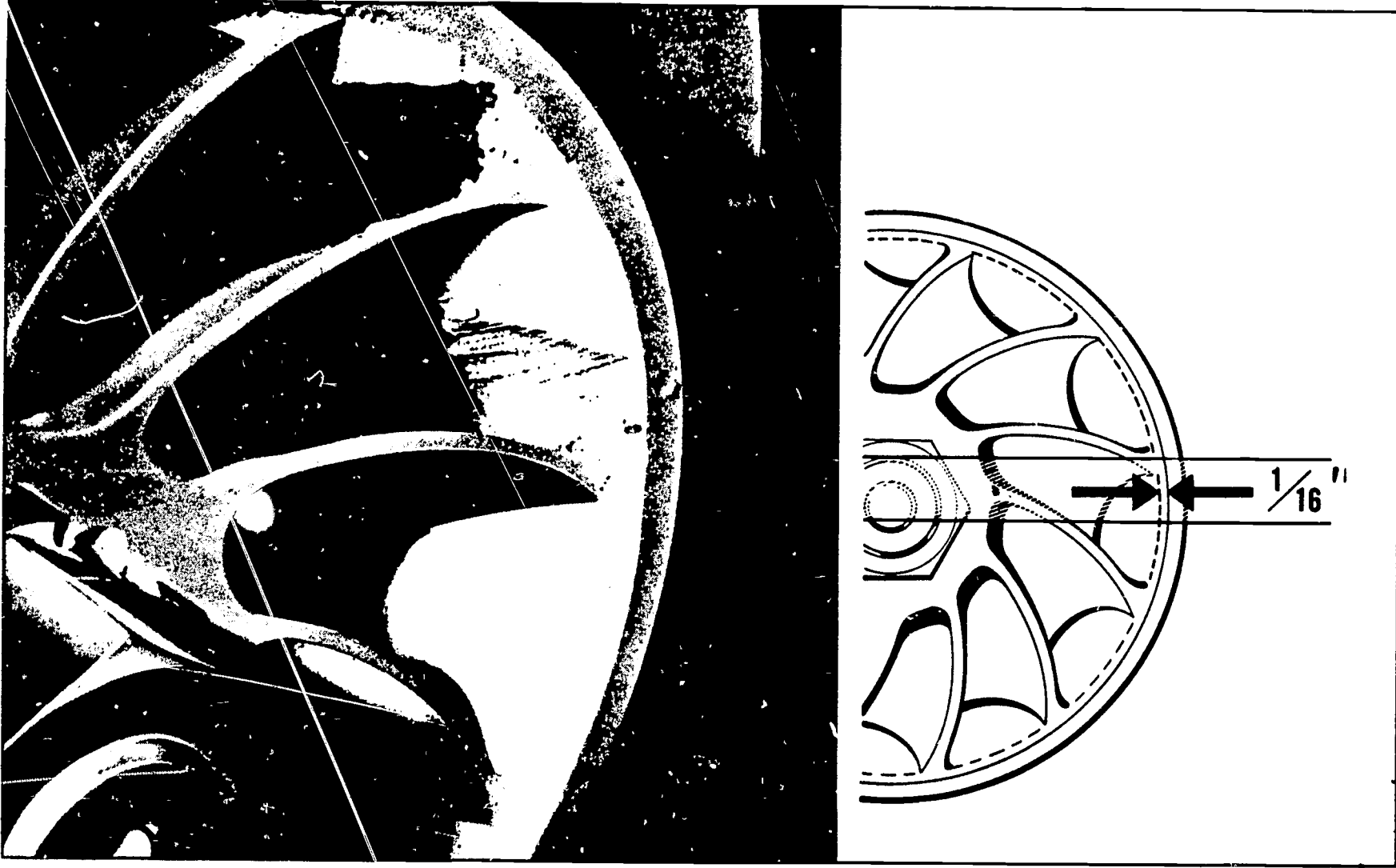

Fig. 16 - Dirt build-up on compressor impeller

6. Place thumb on exposed end of the turbine wheel and push down.
7. Move the compressor impeller up and down while pushing down on turbine wheel.
8. Read dial indicator while moving compressor impeller as noted in Step 7 above.

NOTE: If the total indicator reading exceeds 0.009", in either Step 4 or Step 8, replace rotating cartridge assembly (31).

9. Check axial end play with a dial indicator. Axial end play must be between 0.004" and 0.008".

DISASSEMBLY AND CLEANING -- Disassembly of the turbocharger can be accomplished without the use of special tools or fixtures. The design of the turbocharger provides for straight forward assembly and disassembly. As the

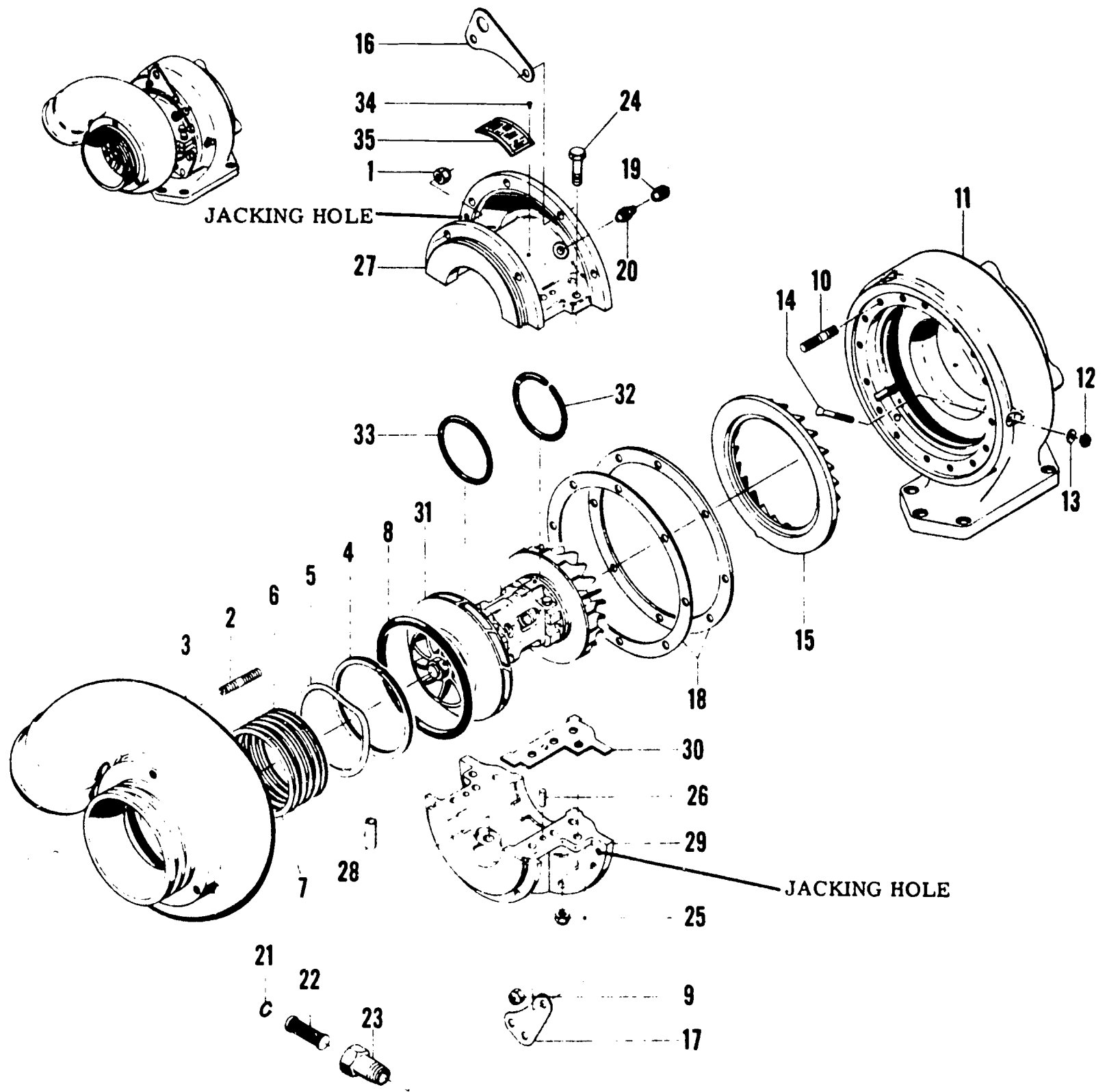

Fig. 17 - Turbocharger details and relative location of parts

- | | | |
|------------------------------|---|------------------------------|
| Nut-Lock-Hex | 14. Bolt-Nozzle Retaining | 24. Bolt |
| Stud | 15. Nozzle | 25. Nut-Lock-Hex |
| Housing-Compressor | 16. Bracket-Lifting | 26. Pin-Dowel |
| Ring-Impeller Seal Retaining | 17. Bracket-Support | 27. Housing-Upper Half Main |
| Washer-Impeller Seal Wave | 18. Shim-Turbine Housing
0.010 in. Thick | 28. Tube-Oil Inlet |
| Spacer-Impeller Seal | 18. Shim-Turbine Housing
0.040 in. Thick | 29. Housing-Lower Half Main |
| Gland-Impeller Seal | 19. Cap Assy.-Sealing Air-Inlet | 30. Gasket-Main Housing |
| Packing-"O" Ring | 20. Nipple | 31. Cartridge Assy.-Rotating |
| Nut-Lock, Hex | 21. Wire-Strainer Retainer Snap | 32. Packing-Carrier |
| Stud | 22. Strainer Assy-Oil | 33. Packing-"O" Ring |
| Housing-Turbine | 23. Extension-Oil Inlet | 34. Screw |
| Nut-Lock-Silver Plated | | 35. Nameplate |
| Gasket-Nozzle Retaining Bolt | | |

parts are removed, place them on a clean workbench in the order of disassembly. Care must be taken to prevent damage to the components while they are on the workbench, see Figure 17.

1. Before cleaning, inspect the components for signs of scoring, burning or other damage which might not be evident after cleaning.
2. Soak all parts except the rotating cartridge assembly in a carbon cleaning solvent. Use a stiff bristle brush to remove clinging dirt deposits. Dry parts thoroughly. It is recommended that parts be dried with filtered, moisture-free air at approximately 20 psi pressure. Use clean lint-free cloths as necessary.

Caution: Use cleaning solvent in a well-ventilated area. Avoid breathing solvent vapors. Observe fire precautions.

3. Soak the compressor impeller in clean solvent for about 20 to 25 minutes. This must be accomplished by placing the rotating cartridge assembly in a vertical position and immersing only the compressor impeller in the solvent. Make sure that solvent does not enter the bearing housing. After soaking, use a stiff bristle brush and remove all dirt particles from the impeller passages. Dry the compressor thoroughly with air or cloths.

Caution: Before the turbocharger is serviced and put back in operation, make sure all foreign matter is removed during cleaning operation.

4. The turbine wheel on the rotating cartridge assembly must be cleaned of carbon and deposits in the same manner as outlined in Step 3.

Note: Normally, a slight build-up of carbon or deposits will not affect the turbine operation.

5. Use a wire brush to clean carbon and deposits from the turbine housing and the turbine nozzle.

INSPECTION AND REPLACEMENT --

1. Inspect all parts for corrosion, nicks or damage. Check all mating flange surfaces for proper alignment. Replace any part which shows measurable wear, or is damaged beyond simple repair.
2. Inspect rotating cartridge assembly (31) for binding, damage

or evidence of rubbing on adjacent parts, and caked or excessive turbine wheel carbon or deposits. Check the operation record or the service record of the turbocharger for any notation of vibration, noisy operation or insufficient engine power output. The rotating cartridge assembly may be continued in service without the necessity of being rebalanced, if the assembly has shown reliable service and passes inspection procedures.

3. If it is necessary to replace seal spacers (6), wave washer (5) must also be replaced.
4. Replace the following parts at each overhaul regardless of condition:
 - a) impeller seal glands (7)
 - b) "O" ring packing (8 and 33)
 - c) nozzle retaining bolt gaskets (13)
 - d) main housing gaskets (30)
 - e) carrier packing (32)

ASSEMBLY -- Before reassembling, check each part to be certain that it is clean. If, during reassembly, any foreign particle should fall into the turbocharger, remove the particle before continuing, even if extensive disassembly is required. For added protection, cover openings with tape and cardboard.

LUBRICATION -- On new units, units that have not been operated for a long period of time, or units just overhauled, the turbocharger rotor bearings require pre-oiling due to the oil having been drained out of the turbocharger. To assure pre-lubrication on starting the engine and prevent any subsequent bearing damage, the following procedure is recommended.

1. Clean area around oil inlet line thoroughly.
2. Disconnect oil inlet line and pump clean engine oil into the turbocharger.
3. Reconnect oil inlet line.

CAUTION: After the turbocharger has been operating for a sufficient time to permit the unit and oil to warm-up, the rotor should coast freely to a stop after the engine is stopped. If the rotor jerks to a sudden stop, the cause should be immediately determined and eliminated.

TURBOCHARGER TROUBLE SHOOTING CHART

Trouble	Probable Cause	Remedy
Noisy operation, or vibration	Bearings are not being lubricated	Supply required oil pressure, clear or replace oil line. After correcting the condition, replacement of the rotating cartridge assembly may be required.
	Impeller seal glands rubbing	Impeller seal glands will seat in after 10 minutes of operation.
	Leakage in engine intake, or exhaust manifold	Tighten loose connections or replace manifold gaskets if necessary.
	Turbocharger rotating cartridge assembly seals rubbing	Replace rotating cartridge assembly.
	Loose fit of rotating cartridge assembly journals or bearings	Replace rotating cartridge assembly.
	Excessive build-up of dirt in compressor or impeller	Thoroughly clean all dirt from compressor impeller, or replace rotating cartridge assembly if bearing clearances are greater than allowed. Clean air cleaner and check air inlet ducting for leakage.
	Excessive build-up of carbon, or deposits on turbine wheel	Replace rotating cartridge assembly.
Engine will not deliver rated power	Clogged manifold system	Clear all ducting.
	Foreign material lodged in compressor or impeller, or turbine wheel	Replace rotating cartridge assembly.
	Leakage in engine intake or exhaust manifold	Tighten loose connections or replace manifold gaskets if necessary.
	Rotating cartridge assembly bearing seizure	Replace rotating cartridge assembly.

SECTION G -- TROUBLE SHOOTING TIPS ON THE AIR SYSTEM

CRANKCASE PRESSURE -- A crankcase pressure reading indicates the amount of air that has passed between the oil control rings and the cylinder liner into the crankcase. Most of this air is clean air from the air box. A slight pressure in the crankcase is needed to keep dust out. A loss of engine lubricating oil through the governor breather tube, crankcase ventilator, or dipstick hole in the cylinder block is an indication of an excessive crankcase pressure.

Some of the causes of high crankcase pressure may be traced to an excessive blow-by due to worn piston rings, a hole or crack in a piston crown, loose piston pin retainers, defective blower, cylinder head or end plate gaskets, or excessive exhaust back pressure. Also, the breather tube or crankcase ventilator should be checked for obstructions.

The crankcase pressure may be checked with the manometer in the engine diagnosis test kit J 7333-04. The manometer should be connected to the oil level dipstick opening in the cylinder block. Check the readings obtained at various engine speeds with the specifications in the Operating Conditions Chart in the maintenance manual.

EXHAUST BACK PRESSURE -- A slight pressure in the exhaust system is normal. However, excessive exhaust back pressure seriously affects engine operation. It may cause an increase in the air box pressure with a resultant loss of efficiency of the blower. This means less air for scavenging, poor combustion and higher temperatures.

The exhaust back pressure, measured in inches of mercury, may be checked with the manometer in the engine diagnosis test kit J 7333-04. The manometer is connected to the exhaust manifold by removing the 1/8" pipe plug which is usually provided for that purpose. However, if there is no opening provided, one can be made by drilling an 11/32" hole in the exhaust manifold companion flange and tapping a 1/8" pipe thread.

Check the readings obtained at various speeds with the specifications in the specific maintenance manual.

AIR BOX PRESSURE -- Proper air box pressure is required to maintain sufficient air for combustion and scavenging of the burned gases. Low air box pressure is caused by a high air intake restriction, damaged blower rotors, an air leak from the air box (such as leaking end plate gaskets), a clogged blower air inlet screen, lack of power, or black or grey exhaust smoke are indications of low air box pressure.

To check the air box pressure, connect the manometer or gauge from engine diagnosis test kit J 7333-04 to the air box of the cylinder block by removing one of the 1/4" pipe plugs located beneath the hand hole cover on the side of the engine opposite the blower, or to an air drain.

Check the readings obtained at various speeds with the specifications in the specific maintenance manual.

AIR INTAKE RESTRICTION -- Excessive restriction of the air intake will affect the flow of air to the cylinders and result in poor combustion and lack of power. Consequently, the restriction must be kept as low as possible considering the size and capacity of the air cleaner.

The air intake restriction may be checked with the manometer or gauge from the engine diagnosis test kit J 7333-04. Connect the manometer to the blower air inlet assembly in the drilled and tapped hole provided for the cold weather starting aid connection. On earlier units in which the hole is not provided, use a current stock air inlet assembly for the test. Check the normal air intake vacuum at various speeds (at no load) and compare the results with the Operating Conditions in the specific maintenance manual.

THE MANOMETER -- The U-tube manometer is a primary measuring device indicating pressure or vacuum by the difference in the height of two columns of fluid.

Connect the manometer to the source of pressure, vacuum, or differential pressure. When the pressure is imposed, add the number of inches one column of fluid travels up to the amount the other column travels down to obtain the pressure (or vacuum) reading.

The height of a column of mercury is read differently than that of a column of water. Mercury does not wet the inside surface; therefore, the top of the column has a convex meniscus (shape). Water wets the surface and therefore has a concave meniscus. A mercury column is read by sighting horizontally between the top of the convex mercury surface (Figure 18) and the scale. A water manometer is read by sighting horizontally between the bottom of the concave water surface and the scale.

Should one column of fluid travel further than the other column, due to minor variations in the inside diameter of the tube or to the pressure imposed, the accuracy of the reading obtained is not impaired.

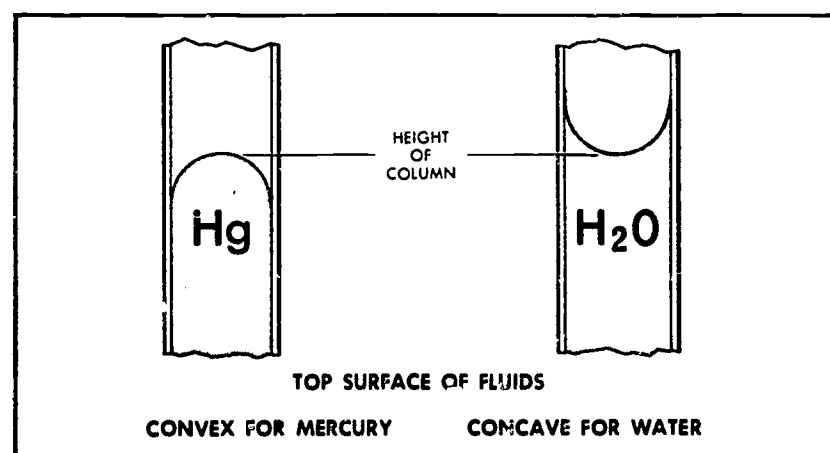

The manometer reading may be converted into other units of measurement by the use of the pressure conversion chart.

Fig. 18 - Comparison of column height for mercury and water manometers.

PRESSURE CONVERSION CHART		
1" water	-	.0735" mercury
1" water	-	.0361 psi
1" mercury	-	.491 psi
1" mercury	-	13.6" water
1 psi	-	27.7"
1 psi	-	2.036" mercury

DIESEL AUTOMOTIVE MAINTENANCE --
DETROIT DIESEL AIR SYSTEM

Human Engineering Institute

Press A

10 65

1

In this program you will be introduced to some of the characteristics of air - and their relation to the air system of a diesel engine.

Press A - 2

1

2

J

WHAT IS AIR? Normally we take it for granted because it cannot be seen. However, just as water is the most common liquid, air is the most common gas.

Gas is a form of matter that does not have a definite shape or volume. (Don't confuse it with gasoline, which is a liquid.) Its molecules (smallest particles) move freely. For example, if you pump some air into a balloon, it immediately becomes evenly distributed all through the space available to it. It does not collect in one spot as water or sand would do.

Press A - 3

1

In which of the following forms of matter do the molecules move the most freely?

- A. Solids. - 4
- B. Liquids. - 4
- C. Gases. - 5

1

4

5

You said molecules move the most freely "in solids or liquids." Let's look at your answer in relation to water. As an icecube, water is a solid form of matter. It possesses a definite shape and volume. When it melts, it becomes a liquid form of matter. It loses its shape, but the volume or amount remains the same. If this water were converted to steam (a form of gas) it would lose its fixed volume. As steam, the water would be evenly distributed in the atmosphere and would seem to "disappear." The reason is that the molecules (smallest particles) of a gas move more freely than the molecules of liquids or solids.

Press A - 5

1

"Molecules move the most freely in gases" is the correct answer.

Although matter differs as to whether or not it has shape and fixed volume, it does have some characteristics in common. All matter has mass and weight. Mass is concerned with the quantity of matter. It is difficult to give an exact definition of mass and we need not be concerned with it at this time. WEIGHT is the amount of pull of the earth's gravity on matter.

Press A - 6

1

6

7

Which one of the following statements is correct?

- A. Air is affected by the earth's pull of gravity and has weight. - 8
- B. Air is not affected by the earth's pull of gravity and has no weight. - 7
- C. Air has no definite shape or volume and therefore has no weight. - 7

1

Your answer is incorrect.

Remember we said that air is a gas and therefore a form of matter. ALL matter is affected by the earth's pull of gravity and has weight.

Press A - 6

1

"Air is affected by the earth's pull of gravity and has weight" is the correct answer.

Because air has weight, it exerts pressure on anything it surrounds, including your own body. The reason you do not feel this pressure is that it is balanced by an equal pressure from the inside--there is air in your body cavities and in the tissues and fluids.

Which one of the following statements is correct?

- A. Air pressure and air weight are the same. - 9
- B. Air pressure is due to the fact that air has weight. - 11
- C. The pressure of air gives it weight. - 10

1

No, your answer is incorrect. Air pressure and air weight are not the same. Matter can exert pressure because it has weight, but they are not the same. You must have weight before you can have pressure.

Press A - 11

1

No, your answer is incorrect. You have pressure and weight confused. Air pressure is due to the fact that air has weight. You must have weight before you can have pressure.

Press A → 11

1

"Air pressure is due to the fact that air has weight" is the correct answer.

The type of air pressure we have been discussing is called atmospheric pressure.

The atmosphere is the body of air surrounding the earth. If it were not for the earth's gravity, this layer of gas would escape into outer space. At sea level, atmospheric pressure amounts to about 14.7 pounds per square inch. At a higher altitude, it would be less.

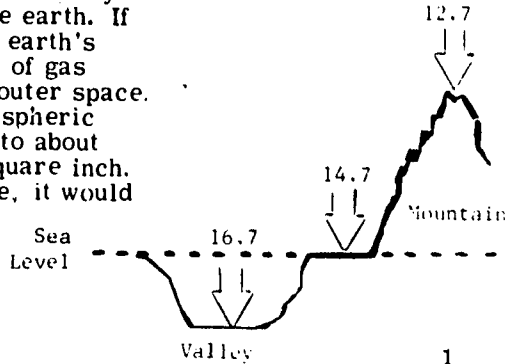

Press A - 12

1

Atmospheric pressure is measured by means of a mercury tube. A glass tube, about thirty six inches long and sealed at one end, is completely filled with mercury. The open end is held closed until the tube is turned over and the open end is set in a dish of mercury. The mercury in the tube will drop away from the sealed end until it is about 30 inches above the mercury in the dish.

This happens because the atmospheric pressure on the mercury in the dish is such that it will support a 30 inch column of mercury.

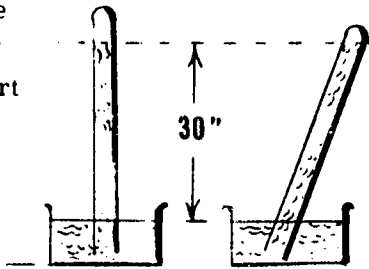

Press A

1

If you had this tube of mercury at an altitude of 10,000 feet, the height of the mercury in the tube would _____

- A. remain the same - 14
- B. drop - 15
- C. rise - 14

1

No, your answer is incorrect. Remember we said at a higher altitude, the atmospheric pressure is less. This means there would be less pressure on the mercury in the dish and the column of mercury would drop part way in the tube.

Press A - 15

1

"The height of the mercury in the tube would drop" is the correct answer.

The atmospheric pressure is less at a higher altitude because the air is thinner or less dense. At a lower altitude, however, the density of the air increases, because of the pressure being exerted by successive layers of air. If you took a mercury tube below sea level (as in Death Valley), the mercury would rise above 30 inches because the atmospheric pressure would be greater.

The atmospheric pressure at sea level is 14.7 psi (pounds per square inch) and is used as a basis for comparison whenever we are measuring pressure.

Press A - 15

1

1-2 D

16

17

When the mercury drops in the tube, it leaves a vacuum at the top of the tube. A VACUUM is a space in which the air pressure is less than the pressure of the atmosphere. (A perfect vacuum exists only when all matter or gases have been removed from a space. This is a very difficult condition to obtain - practically impossible.)

A vacuum would exist whenever the air pressure is less than

- A. 17.4 psi - 17
- B. 11.4 psi - 17
- C. 14.7 psi - 18

1

No, your answer is incorrect. Remember a vacuum exists when the air pressure is less than the pressure of the atmosphere. Atmospheric pressure is 14.7 psi.

Press A - 18

1

18

19

"14.7 psi" is the correct answer.

So far we have talked about the effect of atmospheric pressure on mercury. If water is substituted for mercury, the atmospheric pressure at sea level would support a column of water 34 feet in height. The reason for this difference is that water is less dense - weighs less per cubic inch - than mercury.

The knowledge of the effect of atmospheric pressure on various liquids makes it possible for us to measure the pressure of other gases. To do so we must know the _____ of the liquid being used.

- A. density - 21
- B. total weight - 19
- C. psi - 20

1

No, your answer is incorrect. You must know the density, or weight per cubic inch, of the liquid being used. Knowing the total weight of the liquid would not give you enough information.

Press A - 21

1

20

21

No, you are incorrect. We must know the density, or weight per cubic inch, of the liquid being used. Psi is pounds per square inch and a measure of pressure.

Press A - 21

1

"Density" or weight per cubic inch is the correct answer.

Using the mercury tube, we know that mercury has a density of .49 pounds per cubic inch. If the atmospheric pressure supports 30 inches of mercury, the pressure is equal to $30 \times .49$ or 14.7 pounds. Note, the density of a liquid remains the same regardless of the amount we are talking about. This means that the atmospheric pressure will support a 30 inch column of mercury in a tube 2", 1" or 1 foot in diameter.

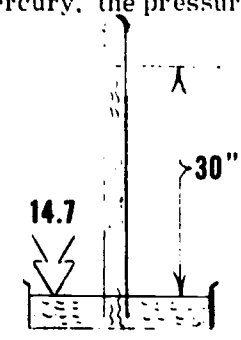

Press A - 22

1

22

23

Our knowledge of the effect of atmospheric pressure on liquids of various densities is used to measure gas pressure with a manometer. A MANOMETER is a glass, U-shaped tube containing water or mercury. The tube is open at both ends and each leg of the tube is marked in inches. When measuring pressure, one end of the tube is connected to the element containing the gas.

Which one of the following illustrations shows how the manometer would appear if the pressure being measured is more than the atmospheric pressure?

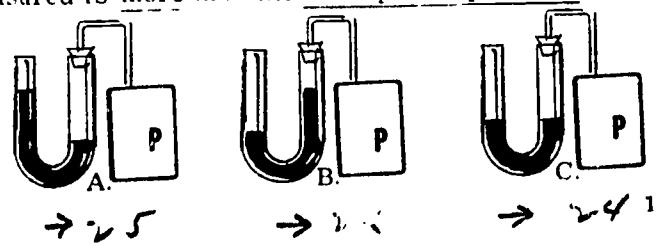

→ 25 → 26 → 24 1

No, your answer is incorrect.

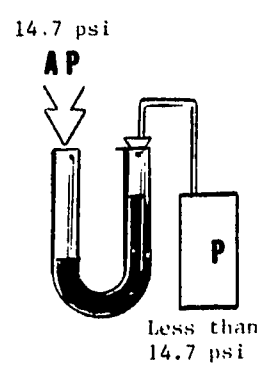

In the illustration you selected, the liquid in the side connected to the element is higher than the liquid in the side exposed to the atmospheric pressure. This would indicate that the pressure being measured is less than atmospheric pressure.

We asked for measurement of a pressure that is greater than atmospheric pressure.

Let's try that question again --

Press A - 22

1

24

No, your answer is incorrect.

In the illustration you selected, the liquid is at the same height in both sides of the tube. This would indicate that the pressure being measured is the same as atmospheric pressure.

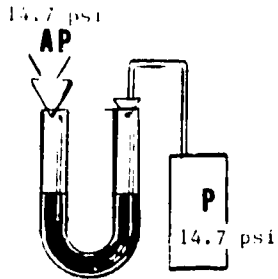

We asked for the illustration showing how the manometer would appear if the pressure being measured is more than the atmospheric pressure.

Let's try that question again --

Press A - 27

1

25

This is the correct illustration of how a manometer would indicate a pressure that is more than atmospheric pressure (14.7 psi).

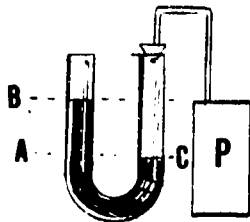

The psi at point A is due to the density of the liquid from points A to B and the atmospheric pressure at the top of the column. The density of the liquid times the distance from A to B, therefore, is the amount by which the gas pressure exceeds the atmospheric pressure.

- A. decreases - 26
- B. equals - 27
- C. exceeds - 28

1

26

No, your answer is incorrect. Atmospheric pressure is used as a basis of comparison. When measuring gas pressure we say it is less than, equals or exceeds the atmospheric pressure. We do not "decrease" atmospheric pressure. In the illustration on the previous frame, the manometer indicates a pressure that is more than the atmospheric pressure. The density of the liquid times the distance from points A to B is, therefore, the amount by which the gas pressure exceeds the atmospheric pressure.

Press A - 28

1

27

No, your answer is incorrect. You said the density of the liquid times the distance from points A to B is the amount the gas pressure "equals" the atmospheric pressure. However, gas pressure either equals atmospheric pressure or it does not equal it. There is no amount involved. In the illustration on the previous frame, the manometer indicates a pressure that is more than the atmospheric pressure. The density of the liquid times the distance from points A to B is, therefore, the amount by which the pressure of the gas exceeds the atmospheric pressure.

Press A - 28

1

"Exceeds" is the correct answer.

In a manometer, the amount of pressure indicated by the density of the liquid times the distance is called gauge pressure or psig. Whenever you see psi it refers to gauge pressure or the amount the pressure exceeds the atmospheric pressure.

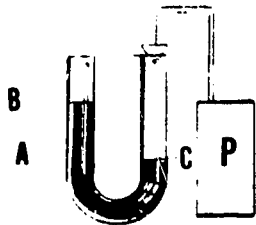

If the atmospheric pressure is added to the gauge pressure, the result is absolute pressure or psia. This is the pressure as it would exist above a perfect vacuum.

Press A - 29

1

28

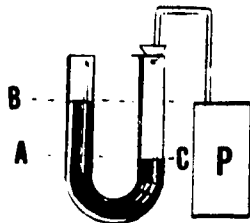

In this manometer the liquid is mercury. The density of mercury is .49 pounds per cubic inch. The distance between point A and B is 5 inches.

measured?

- A. 2.05 - 30
- B. 2.45 - 32
- C. 24.5 - 31

1

30

No, your answer is incorrect. It appears you forgot to carry the "4" when multiplying .49 by 5.

$$\begin{array}{r} 5 \times .49 \text{ is the same as: } 5 \times .40 = 2.00 \\ \text{plus } 5 \times .09 = .45 \\ \hline 2.45 \end{array}$$

Let's try that question again --

Press A - 31

1

31

No, your answer is incorrect. You did not place the decimal mark correctly when you multiplied .49 by 5.

$$\begin{array}{r} .49 \\ \times 5 \\ \hline 2.45 \end{array}$$

Let's try that question again --

Press A - 29

1

7011 1-20

32

"2.45" is the correct answer.

If the above number represents gauge pressure or psig, what would be the psia of that pressure?

- A. 14.75 - 35
- B. 14.7 - 33
- C. 3.92 - 34

1

33

No, your answer is incorrect. "14.7" is the atmospheric pressure. This number must be added to the psi for the psia:

$$\begin{array}{r} 14.7 \\ 2.45 \\ \hline 17.15 \end{array}$$

Try that one again --

Press A - 32

1

34

No, your answer is incorrect. You did not line up the decimal marks correctly when you added the psi to the atmospheric pressure:

$$\begin{array}{r} 14.7 \\ 2.45 \\ \hline 17.15 \end{array}$$

Try that one again --

Press A - 32

1

35

"17.15" is the correct answer.

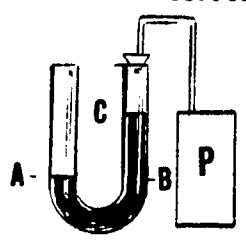

In this manometer the liquid is mercury, which has a density of .49 pound per cubic inch. The distance between points C and B is 9 inches.

What is the psi of the gas being measured?

- A. 4.41 - 38
- B. 3.61 - 36
- C. .58 - 37

1

36

No, your answer is incorrect. It appears you forgot to carry the "8" when multiplying .49 by 9. Here is a "short-cut" method for figuring problems like this:

9 x .49 is the same as: 9 x .40 = 3.60
 plus
 9 x .09 = .81
 4.41

Press A - 35

1

37

No, your answer is incorrect. You added the numbers instead of multiplying them. 9 x .49 = 4.41 Work the problem so you can check your multiplication.

Press A - 35

1

"4.41" is the correct answer.

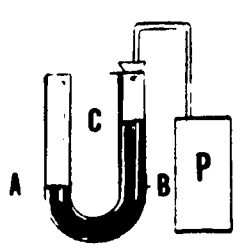

In this problem, because the liquid rose on the closed side of the manometer, we know that a _____ exists in the element where the reading is being taken.

- A. pressure exceeding atmospheric pressure - 37
- B. pressure equalling atmospheric pressure - 39
- C. partial vacuum - 41

1

38

No, your answer is incorrect. Remember, the liquid rose on the closed side of the manometer. We, therefore, know that a pressure less than the atmospheric pressure, or a partial vacuum, exists in the element where the reading is being taken. If the pressure exceeded the atmospheric pressure, the liquid would rise in the other side of the tube.

Press A - 41

1

TAM 1-2D

40

41

No, your answer is incorrect. The liquid rose on the closed side of the manometer. This indicates that a partial vacuum, or a pressure less than the atmospheric pressure exists in the element where the reading is being taken. In a sense, the atmospheric pressure of 14.7 psi is able to push the liquid down the open end of the tube and against the weaker pressure in the element. If the pressures were equal, the liquid would be at the same level in both sides of the tube.

Press A - 41

1

"Partial vacuum" is the correct answer. Remember - a partial vacuum exists whenever the psig is less than 14.7 lbs.

You are doing fine and have answered all the questions correctly.

If you would like to go on to new material, Press A. - 43

If you would like to review the material we have just covered, Press B. - 2

(X C) → 42

1

42

43

"Partial vacuum" is the correct answer.

You missed one or more questions in the preceding portion of this program. Let's review the material. Read carefully and try to answer all the questions correctly. Take your time in working the problems.

Press A - 2

1

PRESSURE AND VACUUM POINTS IN THE DIESEL AIR SYSTEM

As mentioned in the previous portion of this program, gas molecules (remember: air is a mixture of gases) move very freely. They are always trying to spread out or expand. Gas at a high pressure tends to force its way into a vacuum or low pressure area.

The purpose of the BLOWER is to force air into the air box. In the process of doing so, it creates a vacuum or low pressure in the air inlet and shut-down housings. Because of this vacuum, air from the air cleaner forces its way into these housings and thus a continuous supply of air is provided for the diesel engine.

Press A - 44

2

44

45

The engine operating charts specify the proper psi for the air inlet housing. If the psi is too high, it would indicate that the blower is not working properly or there are leaks in the housing.

What would be indicated if the psi is too low?

- A. The blower is working too fast. - 45
- B. There are air leaks in the air inlet housing. - 46
- C. There is an air restriction in the cleaner or housings. - 47

2

No, you are wrong because the blower cannot turn too fast. As you learned in class, the blower rotates in direct proportion to engine rotation (the faster the engine turns, the faster the blower turns). Too low a psi in the air inlet housing would indicate that there is an air restriction in the cleaner or housings.

Press A - 47

2

46

47

No, your answer is incorrect. Air leaks in the inlet housing would permit outside air to come into this normally low pressure area. This would result in too high a psi for the housing. Too low a psi in the air inlet housing would indicate that there is an air restriction in the cleaner or housings.

Press A - 47

2

"An air restriction in the cleaner or housings" is the correct answer.

The blower is constructed to force air into the air box and therefore _____ in the air box.

- A. create a vacuum - 48
- B. build up an air pressure - 50
- C. create a strong current of air with no change of air pressure - 49

2

48

No, your answer is incorrect. The air box is an enclosed area. Forcing more air into a closed area will build up the air pressure. A vacuum is created by drawing air out of an enclosed area.

Press A - 50

2

49

No, your answer is incorrect. Remember the air box is an enclosed area. Forcing more air into a closed area will build up the air pressure. It should also be noted that - because of its nature - a strong current of air produces a high pressure.

Press A - 50

2

50

"Build up an air pressure" is the correct answer.

The correct psi for the air box is indicated in the engine operating chart. Too high a psi would indicate that the air is unable to continue its normal flow through the engine. Since it should flow through the cylinder ports into the cylinder, too high a psi could indicate that the cylinder ports are partially blocked. (A certain amount of pressure, however, is required to force the air through the cylinder ports for scavenging and combustion purposes.)

Which one of the following conditions would be indicated by too low a psi reading in the air box?

- A. Too much air is flowing through the engine. - 51
- B. A restriction exists in the air cleaner or air inlet housings. - 53
- C. The air box seals are too tight. - 52

2

51

No, your answer is incorrect. Remember a certain amount of pressure is necessary in the air box to force the air through the cylinder ports. A low psi reading in the air box would indicate that there is not enough air coming from the blower. This could indicate that a restriction exists in the air cleaner or air inlet housings.

Press A - 53

2

52

No, your answer is incorrect. Remember a certain amount of pressure is necessary in the air box to force the air through the cylinder ports. To maintain this pressure, it is necessary that the air box be tightly sealed. A low psi reading in this area could indicate that there are leaks in the air box, but chances are that there is a restriction at the air cleaner or air inlet housing.

Press A - 53

2

53

"A restriction exists in the air cleaner or air inlet housings" is the correct answer.

Most of the air from the air box flows into the cylinders for scavenging and combustion purposes. A small amount of the air, however, flows into the crankcase - where it maintains a slight air pressure to keep outside air and dirt from entering the crankcase and contaminating the oil. In the process of troubleshooting the air system, psi readings are taken in the crankcase and compared to the other psi readings to pinpoint the trouble.

Press A - 54

2

54

A psi reading is also taken to obtain the exhaust back pressure. The burnt gases that exist in the cylinder after combustion are under a great amount of pressure. The engine is designed to route these gases out the exhaust valves, through the manifold, muffler and exhaust stacks into the outside air. The fresh air that enters the cylinder through the cylinder ports helps to flush these gases out. If the pressure in the manifold, however, is excessive, the fresh air cannot flush the gases out of the cylinder.

Press A - 55

2

55

Excessive back pressure in the manifold has a chain reaction in the diesel air system. If the air cannot be exhausted from the cylinder, it builds up pressure in the air box and in the

- A. crankcase. - 58
- B. air inlet housing. - 56
- C. air cleaner. - 57

2

AM 1-2D

56

, your answer is incorrect. Even with excessive back pressure, the blowers would continue to carry air into the air box and thus create a vacuum in the inlet housing.

The only outlet for air in the air box is through the cylinder and into the crankcase. If excessive exhaust back pressure prevents the normal amount of air from leaving the cylinder, pressure will build up in the crankcase.

Press A - 58

2

57

No, your answer is incorrect. The air cleaner is exposed to regular atmospheric pressure. It is constructed so that air can be drawn into it and sent on its way to the engine.

It is impossible to build up pressure in the cleaner. The only outlet for air in the air box is through the cylinders and into the crankcase. If excessive exhaust back pressure prevents the normal amount of air from leaving the cylinder, pressure will build up in the crankcase.

Press A - 58

2

58

If fresh air cannot be exhausted from the cylinder, it builds up pressure in the air box and crankcase" is the correct answer.

Which one of the following correctly designates the pressure and vacuum points in the diesel air system?

- A. Pressure from the air cleaner to the blower, in the air box, and in the exhaust. Vacuum in the crankcase. -59
- B. Pressure in the air box, crankcase, and exhaust. Vacuum from the air cleaner to the blower. -61
- C. Pressure from the air cleaner to the blower, in the crankcase and in the exhaust. Vacuum in the air box. -60

2

59

You said there was "pressure from the air cleaner to the blower, in the air box and in the exhaust, and a vacuum in the crankcase."

If there was pressure from the air cleaner to the blower in the air inlet housings, how would it be created? The blower is drawing air from this area and thus creates a vacuum from the cleaner to the blower.

Now, there is an opening from the air box to the crankcase. Therefore if we have pressure in the air box, there will also be a pressure in the crankcase.

Press A - 58

2

60

You said there is "pressure from the air cleaner to the blower, in the crankcase and in the exhaust and a vacuum in the air box."

If there was pressure from the air cleaner to the blower, and in the air inlet housing, how would it be created? The blower is drawing the air from this area and this creates a vacuum from the air cleaner to the blower.

Now, the blower is forcing air into the air box. This creates a pressure, not a vacuum. If a vacuum were to exist in the air box, it would be impossible to operate the engine, as there would not be sufficient air for combustion.

Press A - 58

2

61

Yes, the correct pressure and vacuum points in the diesel air system are: pressure in the air box, crankcase, and exhaust; and a vacuum from the air cleaner to the blower.

These pressure and vacuum points are measured with a manometer. Which one of the following illustrations shows how the manometer would appear when measuring the pressure in the air inlet housing if the air system were operating properly?

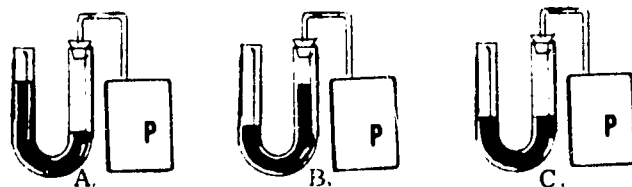

→ 62

→ 64

→ 63

62

No, your answer is incorrect. Remember there is a vacuum in the air inlet housing. The liquid, therefore, would rise on the side of the manometer that is connected to the housing. The illustration you selected showed the liquid higher on the side of the manometer that is exposed to atmospheric pressure. This would indicate that the pressure being measured is more than the atmospheric pressure.

Try that one again--

Press A - 61

2

63

No, your answer is incorrect. Remember there is a vacuum in the air inlet housing. The liquid, therefore, would rise on the side of the manometer that is connected to the housing. The illustration you selected showed the liquid M at the same level on both sides of the manometer. This would indicate that the pressure being measured is the same as the atmospheric pressure.

Try that one again --

Press A - 61

2

P.T.A.M 1-24

64

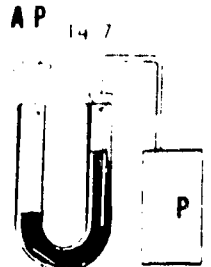

This is the correct illustration of a manometer measuring the pressure in the air inlet housing. A vacuum exists in the housing so the atmospheric pressure is able to push the liquid down on the side of the tube exposed to the atmosphere.

Congratulations, you have answered all the questions in this portion of the program correctly. If you would like to review the material on pressure and vacuum points in the diesel air system, Press A. - 43

To go on to new material, Press B. - 65

X C → 65 2

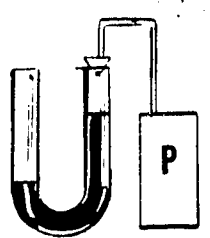

This is the correct illustration of a manometer measuring the pressure in the air inlet housing. A vacuum exists in the housing so the atmospheric pressure is able to push the liquid down on the side of the tube exposed to the atmosphere.

You missed one or more questions in the last portion of this program. Let's review the material. Read carefully and try to answer all the questions correctly.

Press A - 43

2

65

GAS PRESSURE, VOLUME AND TEMPERATURE

There is a definite relationship between the pressure, volume and temperature of gas. Because of this relationship, definite rules can be formulated about the characteristics of gas.

The First Rule states that if the pressure (P) of a gas is held constant or the same, its volume (V) will expand or contract in exact proportion to its absolute temperature.

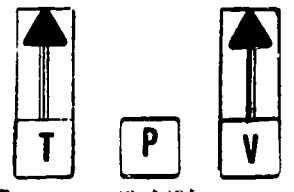

Press A - 67

3

67

Suppose you have two cubic feet of gas at an absolute temperature of 500 degrees and you increase the temperature to 1000 degrees. If the pressure is to remain the same, the gas will have a volume of _____ at an absolute temperature of 1000 degrees.

- A. one cubic foot - 68
- B. three cubic feet - 68
- C. four cubic feet - 67 1/2

3

67 1/2

"Four cubic feet" is the correct answer.

The Second Rule states that at any fixed volume, the absolute pressure of a gas rises or falls in exact proportion to its absolute temperature.

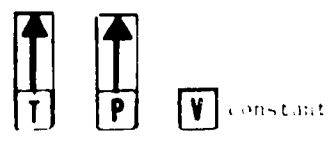

For example, in the problem we just worked, suppose the gas had a pressure of 10 psi. At 500 degrees, the gas occupied two cubic feet of space and the pressure exerted on the container was 10 psi. At 1000 degrees the gas occupied four cubic feet of space but the pressure was still 10 psi.

Press A - 69

3

68

No, your answer is incorrect. Remember the rule states that if the pressure is held constant, the volume will expand or contract in exact proportion to its absolute temperature.

At 500 degrees the gas occupied two cubic feet of space. When the temperature is doubled to 1000 degrees, the volume must be doubled to four cubic feet of space.

Press A - 69

3

69

Now, according to the second rule, what would the psi be if you doubled the temperature but did not permit the gas to expand into a larger container? (If you want to re-read the Second Rule, Press D.) - 69 1/2

- A. 5 psi - 70
- B. 15 psi - 70
- C. 20 psi - 71

3

69 1/2

"Four cubic feet" is the correct answer.

The Second Rule states that at any fixed volume, the absolute pressure of a gas rises or falls in exact proportion to its absolute temperature.

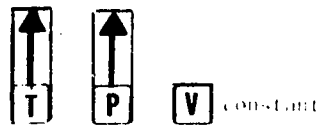

For example, in the problem we just worked, suppose the gas had a pressure of 10 psi. At 500 degrees, the gas occupied two cubic feet of space and the pressure exerted on the container was 10 psi. At 1000 degrees the gas occupied four cubic feet of space but the pressure was still 10 psi.

Press A - 69

3

TAM 1-20

70

No, your answer is incorrect. The second rule states that if the volume is to be held constant and the temperature is increased, the pressure must increase in exact proportion to the temperature.

At 500 degrees, the gas occupied a space of two cubic feet and exerted a pressure of 10 psi. Now the temperature was doubled to 1000 degrees, but the gas was not permitted to expand. Because it could not expand, its pressure was doubled, to 20 psi.

Press A - 71

3

71

"20 psi" is the correct answer.

The third rule about gas states that if the absolute temperature of a gas is to remain the same, the volume of a gas is in an opposite or inverse proportion to its pressure.

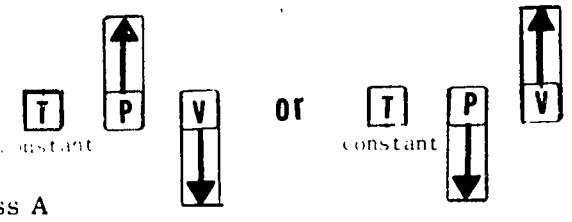

Press A - 72

3

72

Let's take our same problem again. The absolute temperature of the gas is 500 degrees. The gas occupies two cubic feet of space and has a pressure of 10 psi. Now suppose this gas is forced into one cubic foot of space. If the temperature is to remain at 500 degrees, the pressure will be _____.

- A. 5 psi - 74
- B. 10 psi - 73
- C. 20 psi - 73

3

73

No, your answer is incorrect. Remember, the third rule states that if the absolute temperature of a gas is to remain the same, its volume will be in opposite proportion to its pressure. This means if you increase the volume, you decrease the pressure. Or, if the volume decreases, the pressure increases.

In our problem the absolute temperature of the gas was 500 degrees and was to remain the same. The gas occupied two cubic feet of space and has a pressure of 10 psi. Now we decreased the volume of the gas to one cubic foot of space or by one-half. In doing so, we increased the pressure of the gas to 20 psi.

Press A - 74

3

74

"20 psi" is the correct answer.

Let's take a look at how these gas rules apply to a diesel. When the blower forces air into the air box it is _____.

- A. decreasing the air volume and increasing the air pressure. - 76
- B. increasing the air volume and decreasing the air pressure. - 75
- C. increasing both the air volume and the pressure. - 75

3

75

No, your answer is incorrect. When the blower forces air into the air box, it is forcing the outside air into a confined area. Therefore it is decreasing the volume of this outside air and increasing its pressure.

Press A - 76

3

76

"When the blower forces outside air into the air box it is decreasing the air volume and increasing the pressure." In other words, because the amount of space or volume outside the engine is much greater than the amount of space or volume of the air box, air is being forced into a smaller space (decreasing its volume) and increasing its pressure.

At the same time the temperature of the air is _____.

- A. staying the same. - 77
- B. decreasing. - 77
- C. increasing. - 78

3

77

No, your answer is incorrect. The air box is a confined area and, therefore, its volume is constant. According to the rules that govern gas, if the volume is constant and the pressure is increased the temperature will increase in direct proportion to the pressure.

Press A - 78

3

STAM 1 - 22

78

"When the air pressure in the box increases, the air temperature is increasing" is the correct answer.

In the cylinder, on the compression stroke of the piston, there is no constant factor but the effect of the rules still applies.

As the piston comes up on the compression stroke, it decreases the volume, or space occupied by the air. If we refer to our rules about gas, we know that if we decrease the volume of a gas, we increase the pressure. When we increase pressure and do not increase volume, we also cause the temperature of the gas to increase.

Press A - 79

3

79

Fuel is then injected into a small volume of air that is at a very high pressure and a very high temperature. When the fuel ignites it raises the gas temperature even higher and also _____

- A. increases the volume of the gas. - 80
- B. increases the pressure of the gas. - 81
- C. decreases the volume of the gas. - 80

3

80

No, your answer is incorrect. Think a moment about the operation of the piston. At the time the fuel is injected into the cylinder, the piston is near the top of its stroke and there is no space for expansion of the gas. Therefore, the rise in temperature causes the pressure of the gas to increase.

Press A - 81

3

81

"When the fuel ignites it raises the gas temperature and also increases the pressure of the gas" is the correct answer.

Now, the pressure of the gas increases until it reaches a point where it can force the piston down. When the piston goes down the exhaust valves open, and the volume of the gas can increase.

When the gas volume increases, what happens to the gas temperature and gas pressure?

- A. Both the gas temperature and gas pressure will tend to decrease. - 83
- B. The gas temperature will stay the same but the pressure will decrease. - 82
- C. Both the gas temperature and gas pressure will tend to increase. - 82

82

No, your answer is incorrect. The gas rules state that if the volume increases, the pressure decreases. In this application, we do not have a constant temperature factor. Therefore as the pressure decreases, so will the temperature decrease.

Press A - 83

3

83

"Both the gas temperature and gas pressure will decrease" is the correct answer.

These gases, however, are still at a temperature much higher than the outside temperature, and at a pressure much greater than the atmospheric pressure. This pressure forces them through the exhaust system to the outside air. In the process of blending into the atmosphere, the gas volume increases until it would be impossible to measure it. When its volume increases in this manner its temperature and pressure _____

- A. stay the same. - 84
- B. decrease until they reach those of the atmosphere. - 85
- C. will exceed that of the atmosphere. - 84

84

No, your answer is incorrect. Let's look at the gas rules again.

When the volume of a gas increases, the pressure decreases. Now, if the temperature is not held constant, it will also decrease because the pressure decreases.

Press A - 85

X C -> 86

3

85

"The volume of gas coming from the exhaust system increases and its temperature and pressure decrease until these factors reach those of the atmosphere" is the correct answer.

Congratulations! You have answered all the questions correctly and should now have a good knowledge of air pressure and how it affects the operation of the diesel engine.

Press Rewind or if you would like to review the last portion of the tape, press A. - 86

7 AM 1 - 2 D

86

"The volume of gas coming from the exhaust system increases and its temperature and pressure decrease until these factors reach those of the atmosphere" is the correct answer.

You missed one or more questions in this last portion of the tape. Let's review the material. Read carefully and try to answer all the questions correctly.

Press A - 66

3

PTAM 1-2

①

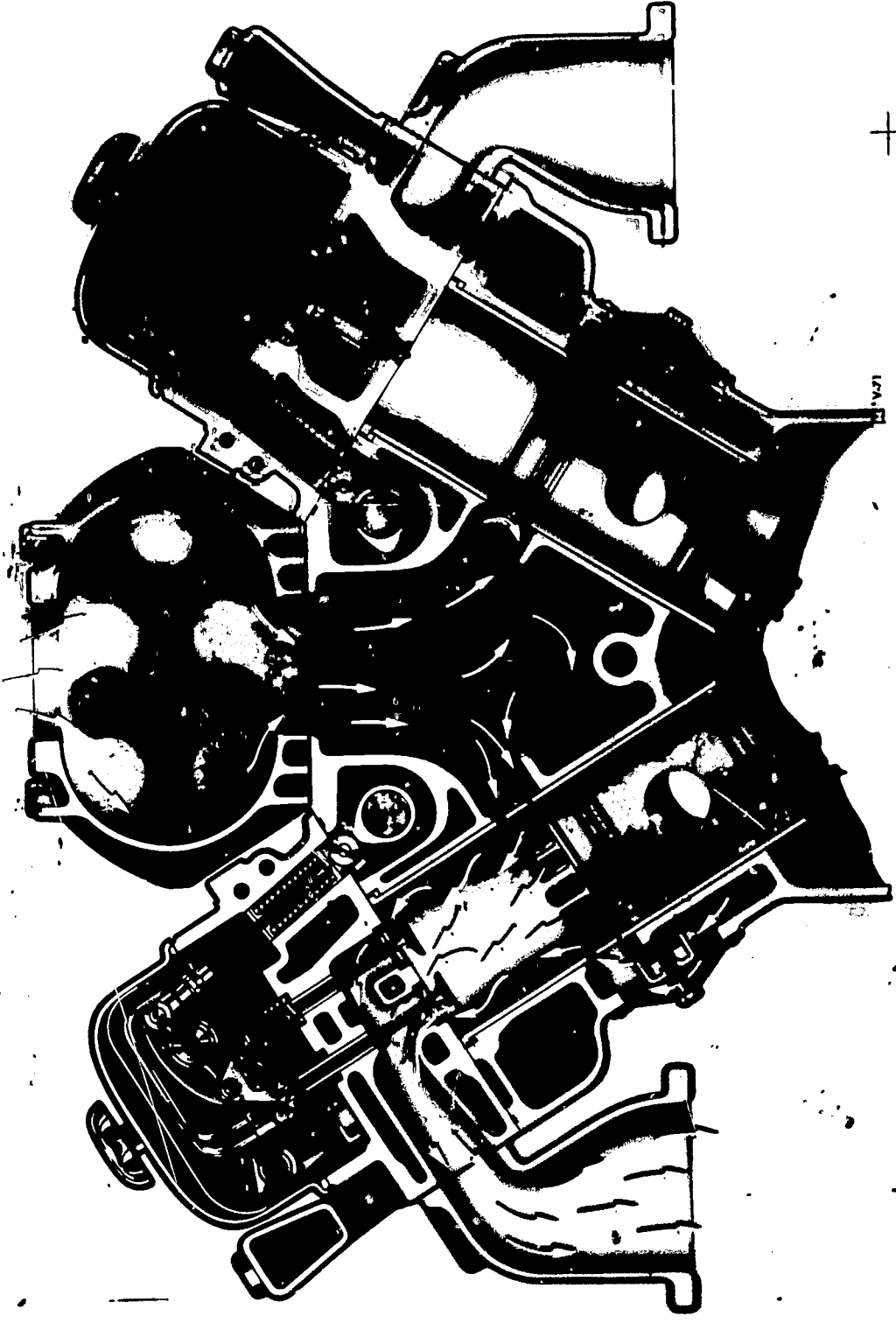

**HUMAN
ENGINEERING
INSTITUTE**

2341 Carnegie Ave
Cleveland, Ohio 44115



®

EXECUTIVE DEVELOPMENT • PERMANENT PERSONNEL

PTAM 1-2 (2)

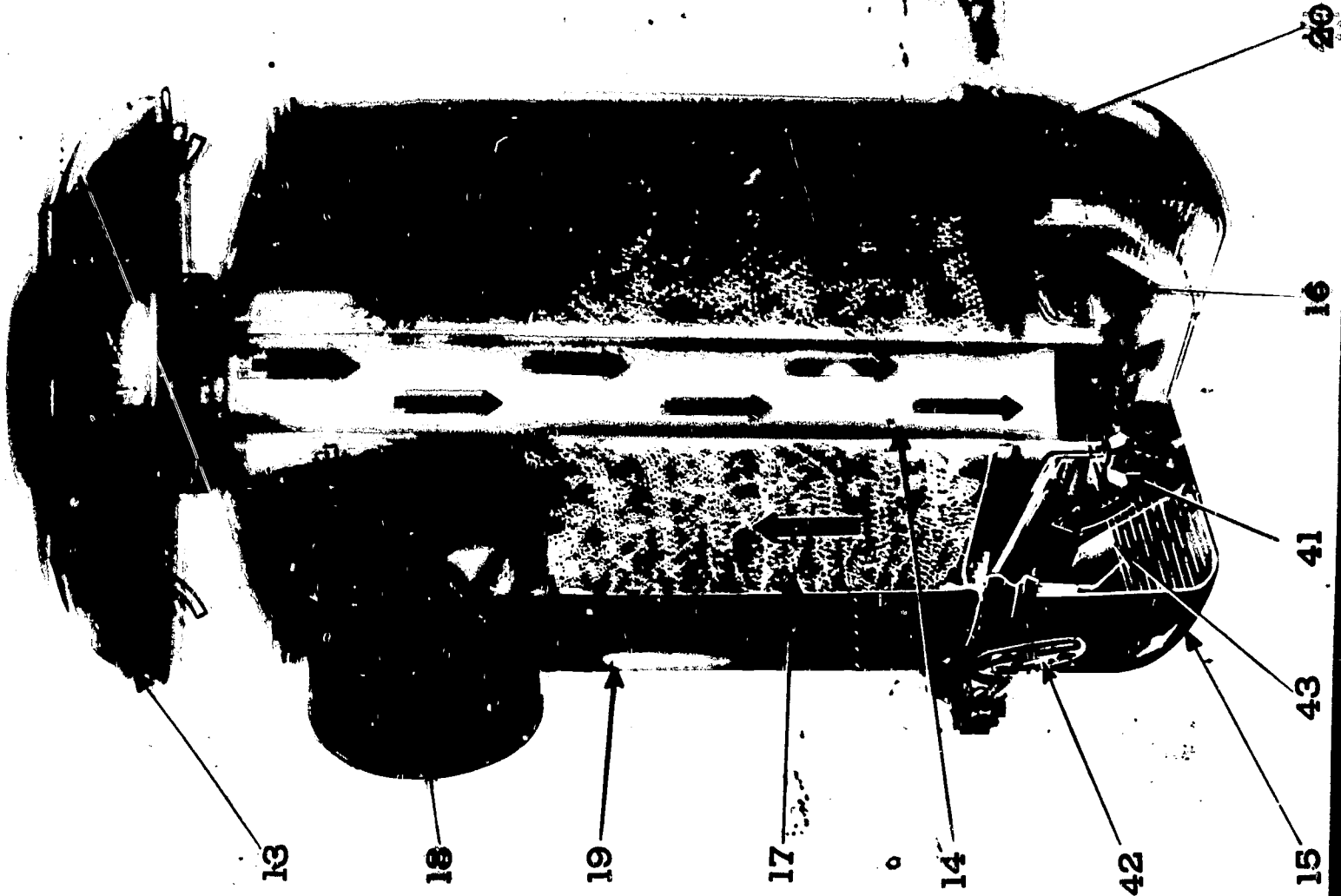

need 10.L.



HUMAN
ENGINEERING
INSTITUTE

2341 Carnegie Ave
Cleveland, Ohio 44115

(R)

EXECUTIVE DEVELOPMENT • PERSONNEL TRAINING • PERSONNEL MANAGEMENT

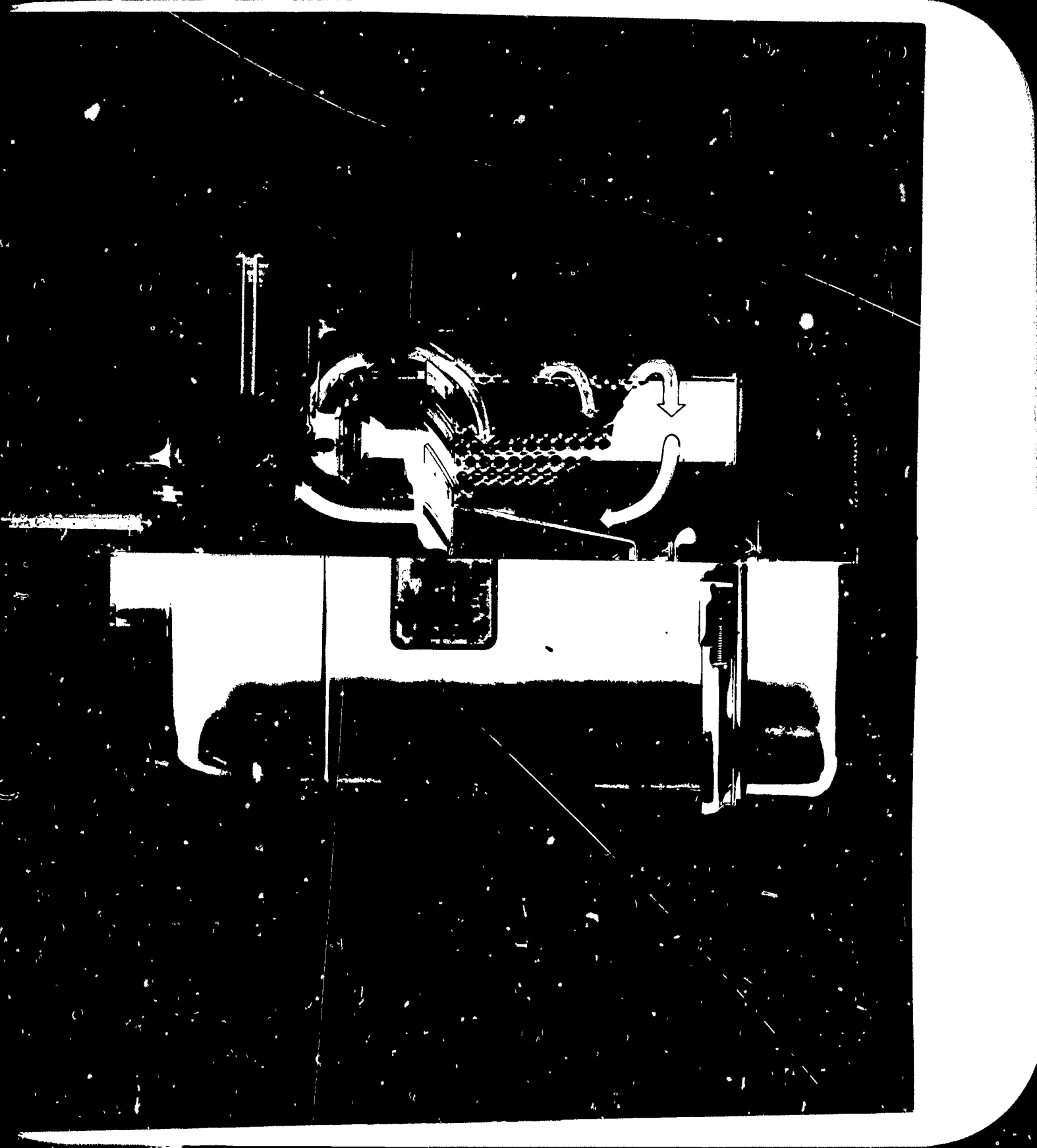

HUMAN
ENGINEERING
INSTITUTE

2341 Carnegie Ave
Cleveland, Ohio 44115

(R)

PTAM 1-2 (4)

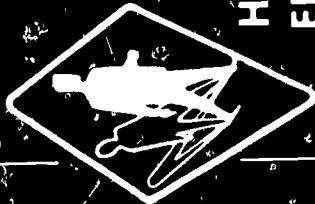
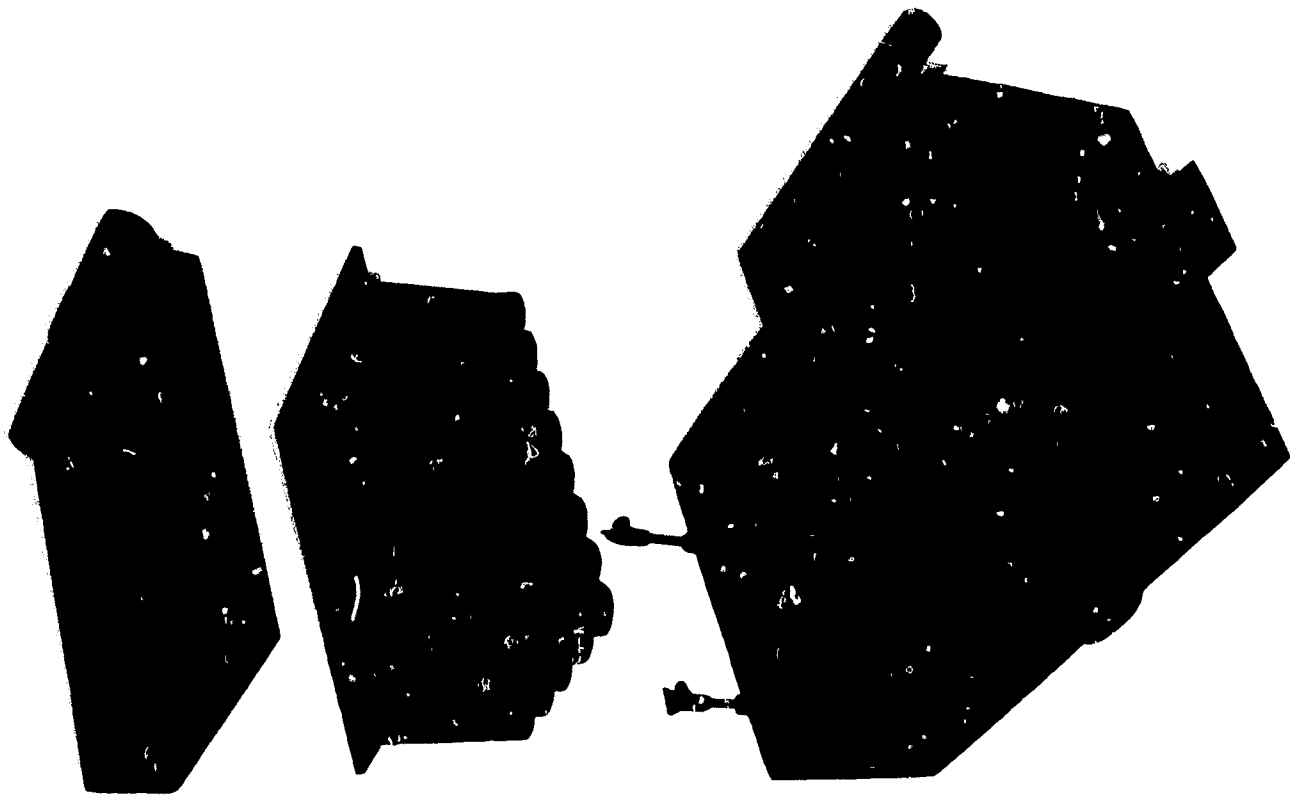

HUMAN
ENGINEERING
INSTITUTE

2341 Carnegie Ave.
Cleveland, Ohio 44115

PTAM-2 (5)

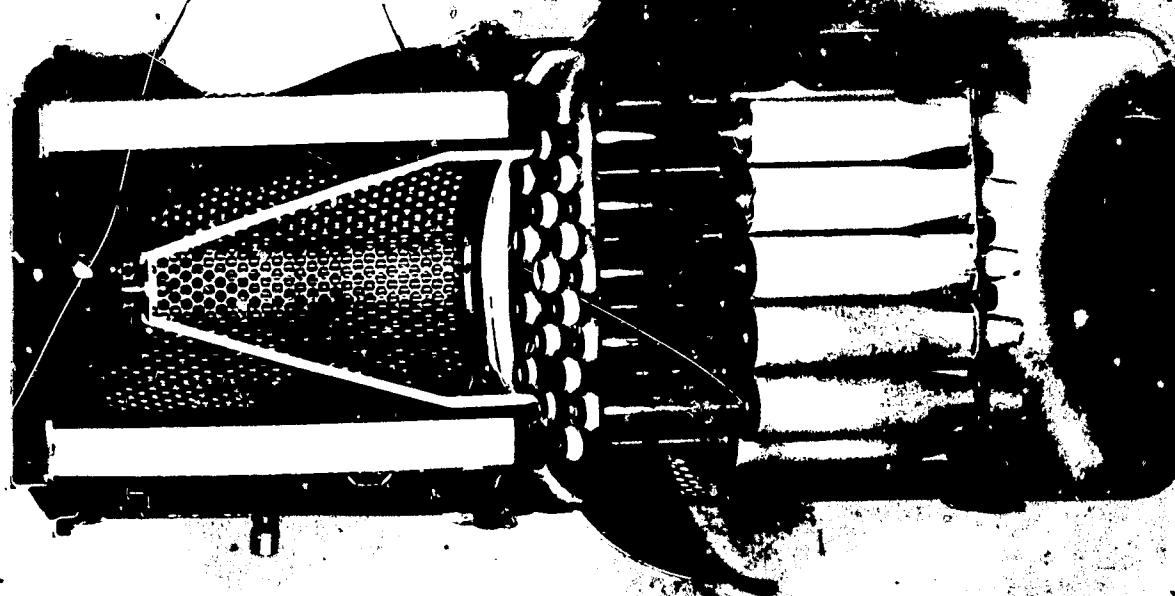

HUMAN
ENGINEERING
INSTITUTE

2341 Carnegie Ave
Cleveland, Ohio 44115

PHM126

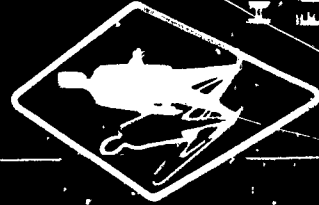

HUMAN
ENGINEERING
INSTITUTE

2341 CAMPUS DRIVE
ANN ARBOR, MICHIGAN 48106

PTAMI-2 (7)

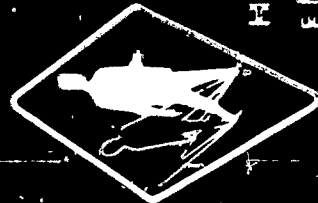
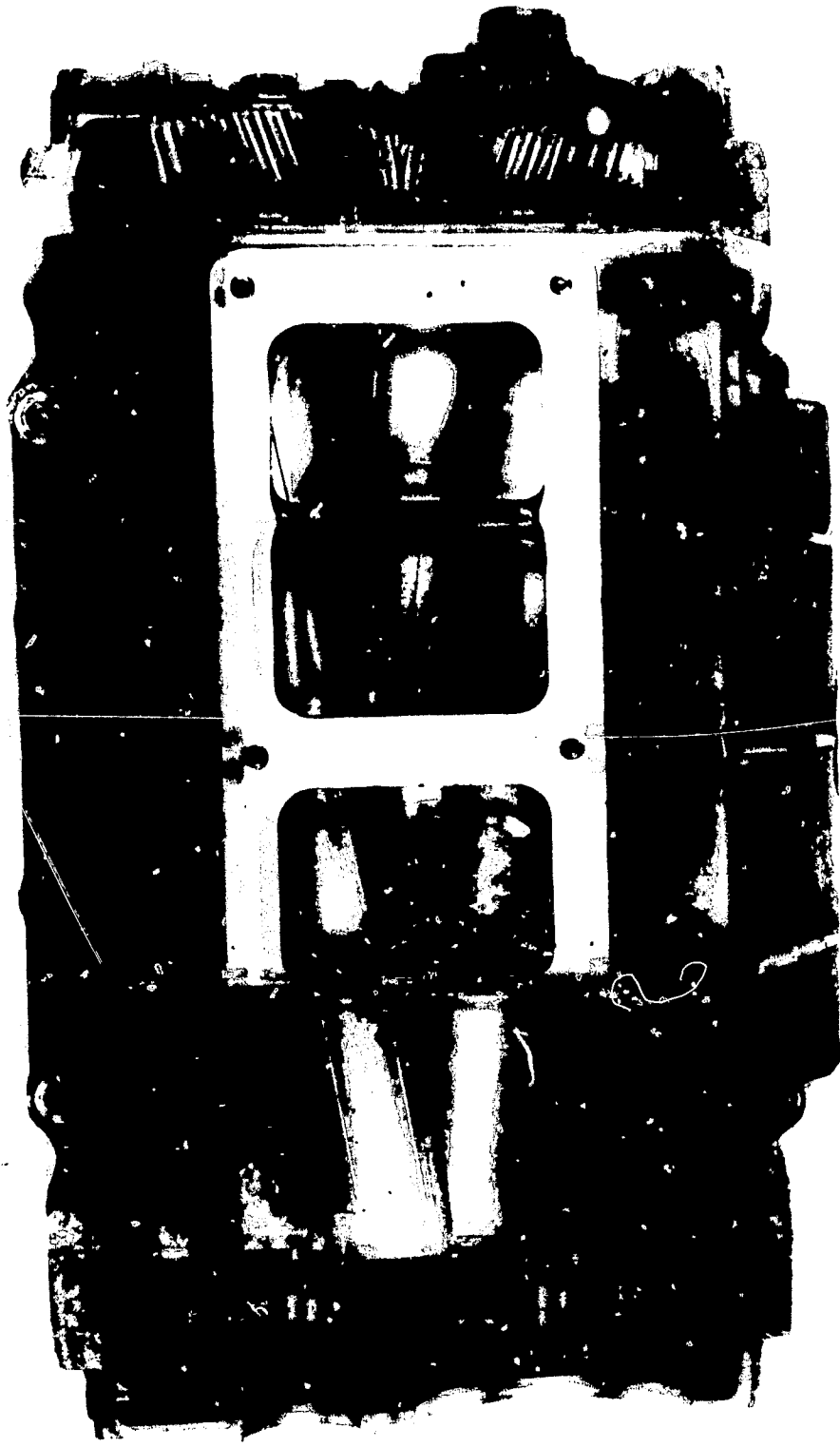

HUMAN
ENGINEERING
INSTITUTE

HUMAN
ENGINEERING
INSTITUTE

2341 Carnegie Ave
Cleveland, Ohio 44115

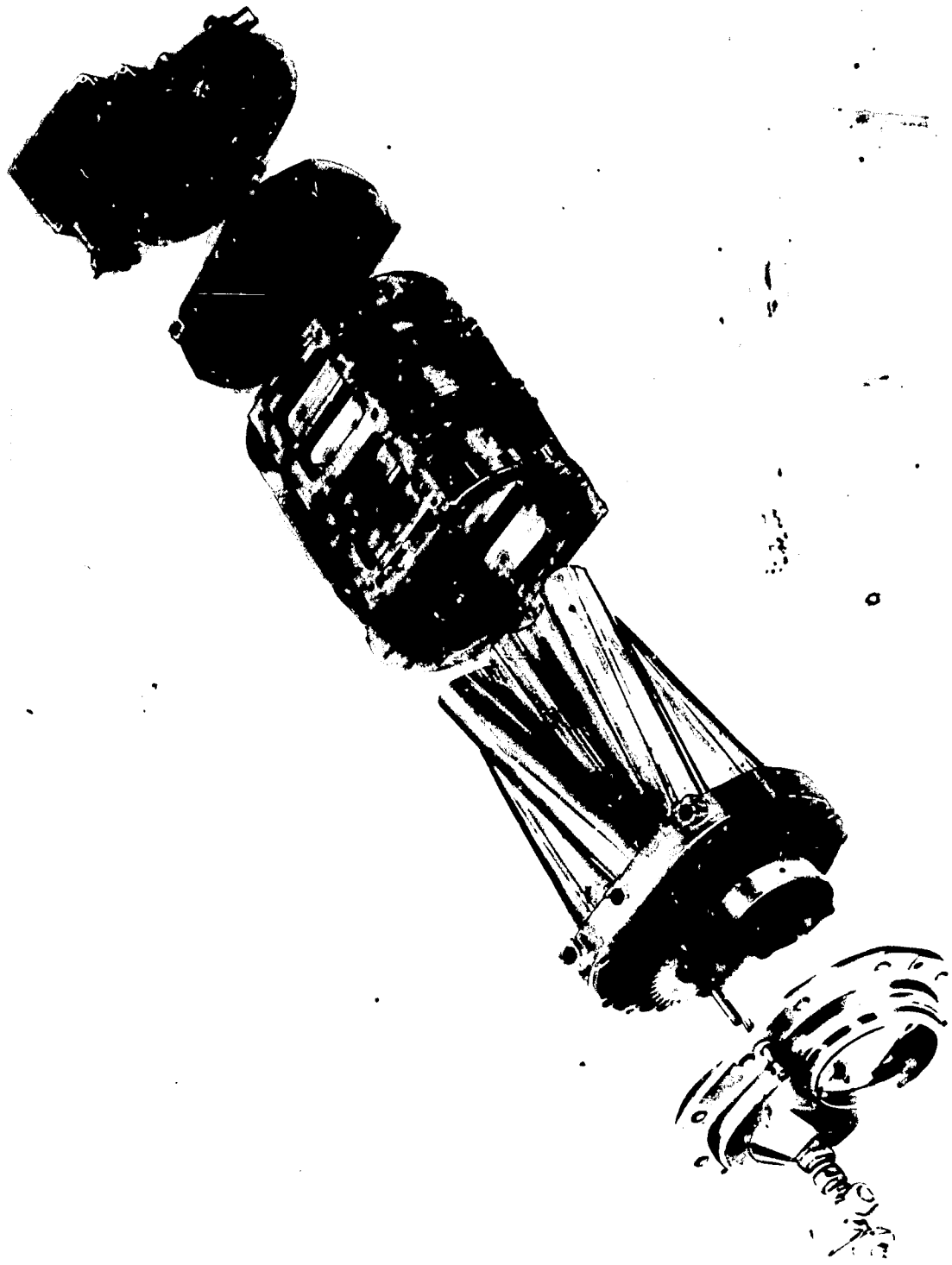

BLOWER SPECIFICATIONS

SERIES	A	B	C	CC	D	E
6-71	MIN. .007	MAX. .004	.002	.006	.006	.004
4-71	MIN. .007	MAX. .009	.004	.002	.006	.004
3-71	MIN. .007	MAX. .007	.012	.002	.006	.004

LEGEND
 A--MOTOR TO END-PLATE CLEARANCE (GEAR END)
 B--GOTOR TO END-PLATE CLEARANCE (OPPOSITE TO GEAR END)
 C--CLEARANCE BETWEEN LEADING UPPER AND TRAILING LOWER LOBES
 CC--CLEARANCE BETWEEN TRAILING UPPER AND LEADING LOWER LOBES
 D--MOSSES TO LOBE-TIP CLEARANCE--INLET SIDE
 E--MOSSES TO LOBE-TIP CLEARANCE--OUTLET SIDE

CHECK "A" AND "B"
 CLEARANCES ON EACH
 LOBE OF BOTH ROTORS

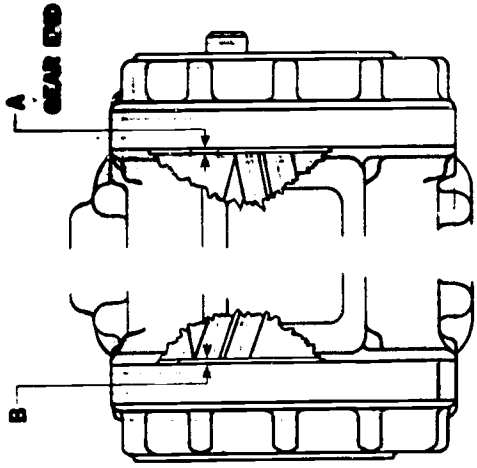

CHECK "CC" AND "C"
 CLEARANCES BETWEEN ALL
 LOBES--FROM OUTLET SIDE

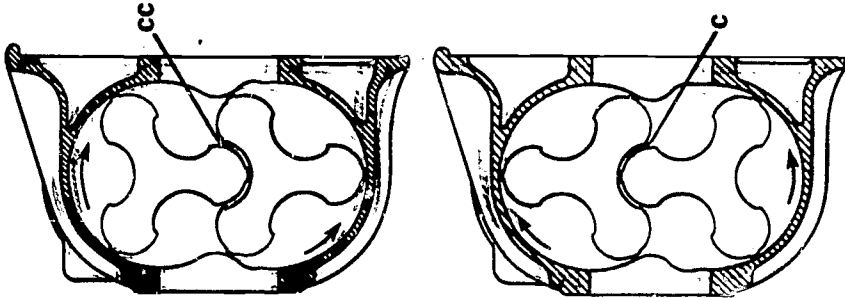

CHECK "CC" AND "C"
 CLEARANCES BETWEEN ALL
 LOBES--FROM INLET SIDE

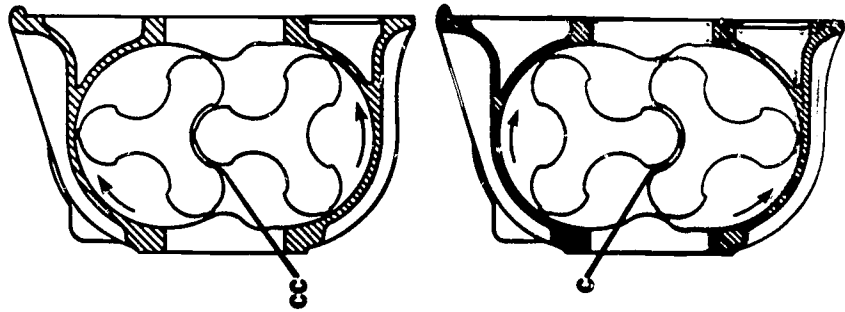

CHECK "D" AND "E"
 CLEARANCES
 ON ALL LOBES

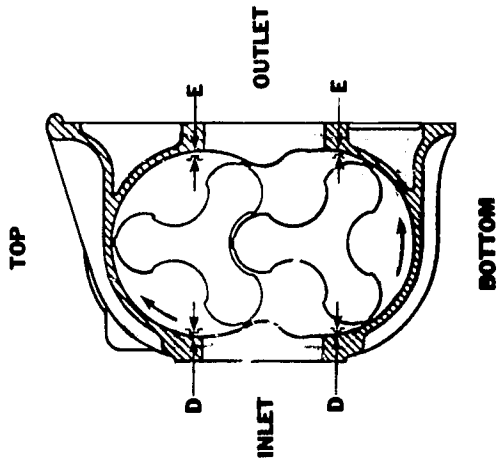

LEFT HAND BLOWER
 RA, RB, LA AND LB
 ENGINES
 G. H. H. P. A. J.
 VIEWS FROM GEAR END

P7AM1-2

9

**HUMAN
 ENGINEERING
 INSTITUTE**

2344 Carnegie Ave.
 Cleveland, Ohio 44115



BLOWER SPECIFICATIONS

SERIES	A	B	C	CC	D	E
6-71	MIN. .007	.004	.004	.002	.006	.004
	MAX.			.006		
4-71	MIN. .007	.009	.004	.002	.006	.004
	MAX.			.006		
3-71	MIN. .007	.007	.002	.002	.006	.004
	MAX.			.006		

LEGEND

- A - ROTOR TO END-PLATE CLEARANCE (NEAR END)
- B - ROTOR TO END-PLATE CLEARANCE (OPPOSITE TO GEAR END)
- C - CLEARANCE BETWEEN LEADING UPPER AND TRAILING LOWER LOBES
- CC - CLEARANCE BETWEEN TRAILING UPPER AND LEADING LOWER LOBES
- D - HOUSING TO LOBE-TIP CLEARANCE - INLET SIDE
- E - HOUSING TO LOBE-TIP CLEARANCE - OUTLET SIDE

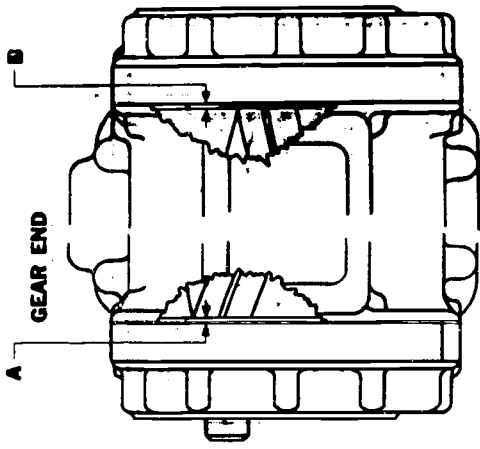

CHECK "A" AND "B" CLEARANCES ON ALL LOBES OF BOTH ROTORS

CHECK "CC" AND "C" CLEARANCES BETWEEN ALL LOBES - FROM OUTLET SIDE

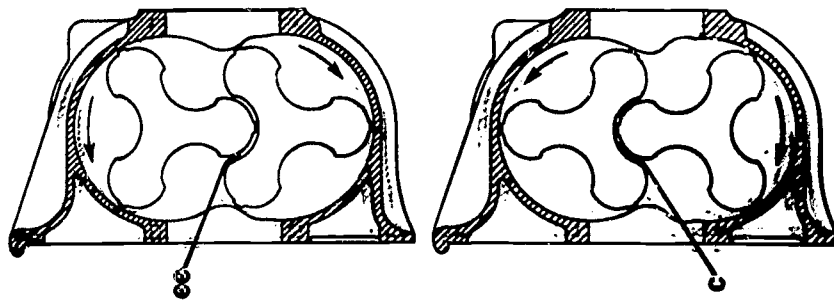

CHECK "CC" AND "C" CLEARANCES BETWEEN ALL LOBES - FROM INLET SIDE

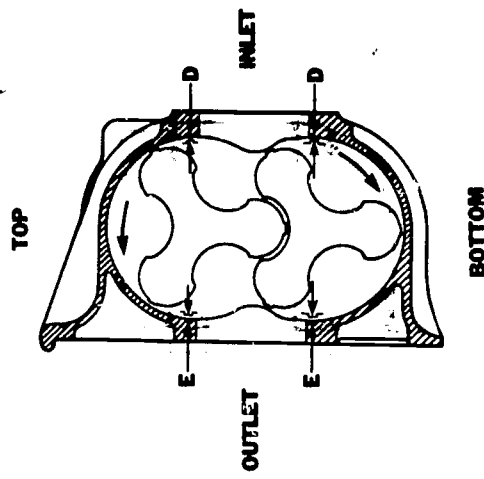
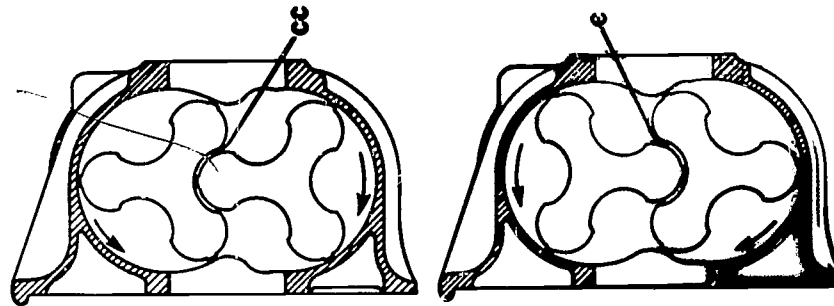

RIGHT HAND BLOWER
RC, RD, LC AND LD
ENGINES
VIEWS FROM GEAR END

PTAM-2
10

HUMAN
ENGINEERING
INSTITUTE

2341 Carnegie Ave.
Cleveland Ohio 44115



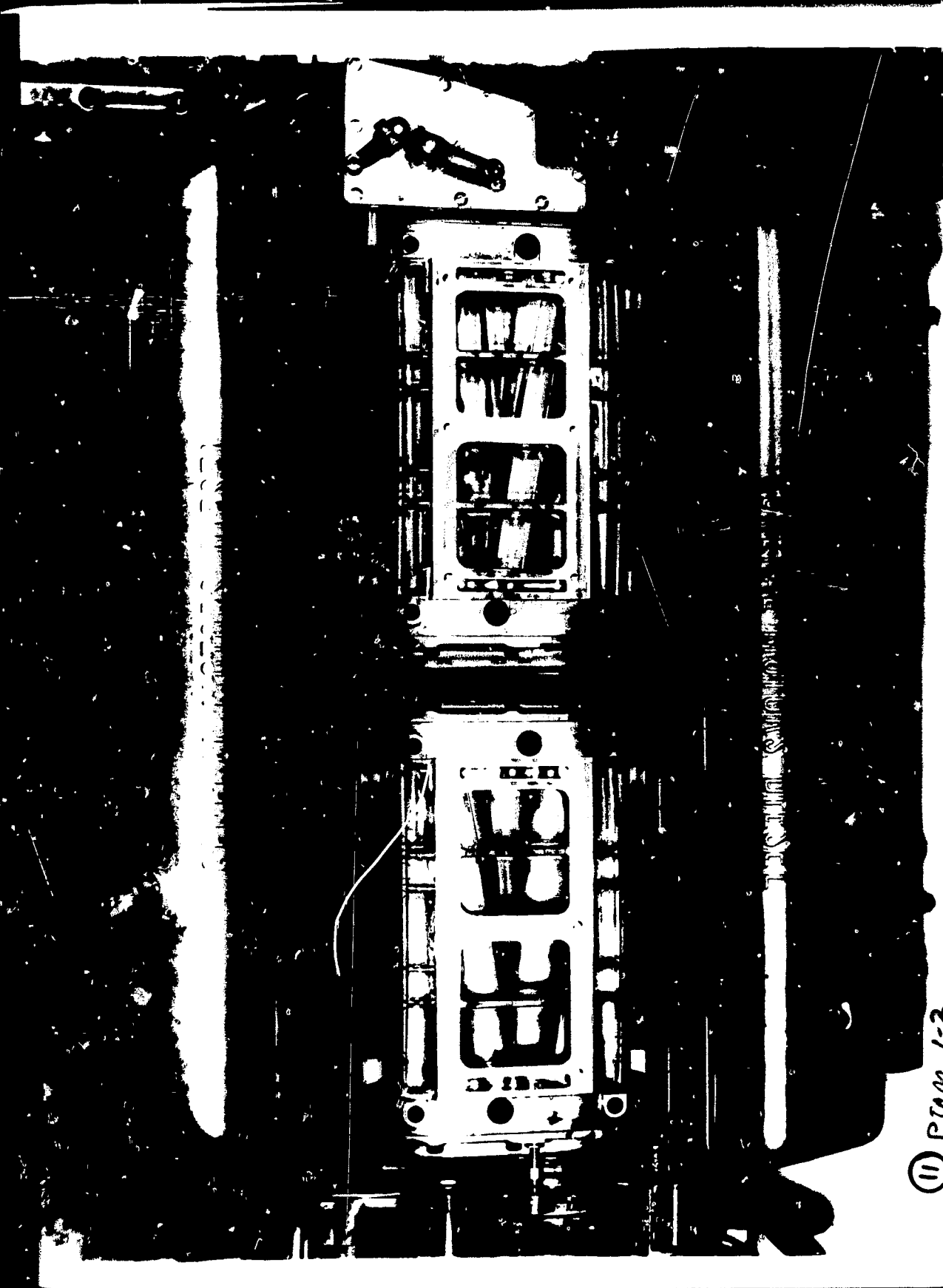

⑩ PTM 1-2

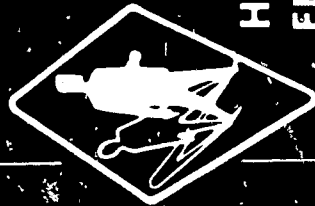

HUMAN
ENGINEERING
INSTITUTE

2341 Carnegie Ave
Cleveland, Ohio 44115

INSTRUCTOR'S GUIDE

Title of Unit: MAINTAINING THE AIR SYSTEM -
DETROIT DIESEL ENGINES

9/27/65
CODE: PTAM 1-2

FIRST -- Be sure all questions on the past Didactor unit have been answered. This step is most important, as the past week has been you students first experience with the machine.

OBJECTIVES: By the end of class each student should be familiar with:

The need for proper maintenance.
The operation of the air system.
Knowledge of the cylinder liner ports.
Functions of the air filter.
 Specifics of the oil bath and two stage.
Knowledge of the air shut down housing.
Knowledge of the exhaust system.
Knowledge of the exnaust manifold.
Some trouble-shooting tips -- how to interpret them.
Knowledge of the blower.
Knowledge of the turbocharger.
Trouble-shooting the turbocharger.
General trouble-shooting tips -- how to interpret them.
Proper use of manometer.

TRAINING AIDS:

Wall charts from Detroit Diesel - TA 301, TA 302 (Show only air system). Any visual aids you have available - such as different types of air cleaners (how they differ), a blower (preferably cutaway), a turbocharger, a manometer (how and where to use it) etc. More visual aids mean less misunderstanding.

The following vu-graphs:

D130-3 (Air intake and exhaust system - I-71)
D130-5 (Blower Spec.)
D130-6 (Blower Spec.)
D130-8 (Blower cutaway)
D130-11 (Blower Functions)
D130-12 (Blower Cutaway)
D130-4 (Air Cleaner - Oil bath)
D130-15 (Air cleaner - dry)
D130-16 (Air filter - dry)
D620-8 (Dual Blowers - V 71)
D630-1 (Air system flow - V 71)
D630-6 (Blower - construction)

Consu't operators and maintenance manuals.

QUESTIONS:

1. Trace the flow of air through the air system and its components.
 2. What are the functions of the cylinder liner ports? How are they constructed? How are they maintained?
 3. How can the air box covers be inspected?
 4. What are the different types of air cleaners?
How are they maintained?
How do they differ?
 5. What does the air shut down housing do?
How is it maintained?
 6. Why is scavenging important?
 7. What does the exhaust manifold do?
What is back pressure?
How is the exhaust system maintained?
 8. What is indicated by:
Black or grey smoke?
Blue smoke?
White smoke?
What are the remedies?
 9. How is the blower constructed?
How does it operate?
How is it maintained?
 10. What is the turbocharger?
How is it constructed?
How is it maintained? (Cover disassembly, cleaning, assembly, lube).
What do you look for when trouble-shooting?
 11. What trouble-shooting tips do you know on:
Crankcase pressure?
Exhaust back pressure?
Air box pressure?
Air intake pressure?
 12. How do you use a manometer?
 13. When do you use a manometer?
 14. What about the conversion chart?
-