

R E P O R T R E S U M E S

ED 020 902

SE 004 884

INDUSTRIAL RADIOGRAPHY STUDENT GUIDE AND LABORATORY EXERCISES.

REPORT NUMBER OE-84035

PUB DATE 68

ATOMIC ENERGY COMMISSION, OAK RIDGE, TENN.

EDRS PRICE MF-\$0.50 HC-NOT AVAILABLE FROM EDRS. 70P.

DESCRIPTORS- *INSTRUCTIONAL MATERIALS, *LABORATORY MANUALS, *NUCLEAR PHYSICS, *TEACHING GUIDES, ADULT EDUCATION, CHEMISTRY, EDUCATIONAL PROGRAMS, PHYSICS, RADIOSOTOPES, SCIENCE ACTIVITIES, TECHNOLOGY, VOCATIONAL EDUCATION, UNITED STATES OFFICE OF EDUCATION, UNITED STATES ATOMIC ENERGY COMMISSION,

THIS INSTRUCTOR'S GUIDE TO AN 80-HOUR COURSE IN INDUSTRIAL RADIOGRAPHY IS COORDINATED WITH LESSONS IN THE STUDENT GUIDE AND LABORATORY EXERCISES AND IS BASED ON MATERIAL IN THE COURSE MANUAL, INDUSTRIAL RADIOGRAPHY. THE COURSE IS INTENDED TO TRAIN HIGH SCHOOL GRADUATES AS BEGINNING RADIOGRAPHERS WHO ARE EXPECTED TO BE ABLE TO EXTEND THEIR KNOWLEDGE THROUGH FIELD EXPERIENCES AND CONTINUED STUDY. DEVELOPMENT OF THESE MATERIALS AROSE FROM THE U. S. ATOMIC ENERGY COMMISSION'S CONCERN FOR (1) REDUCING OVEREXPOSURE HAZARDS TO RADIOGRAPHERS, AND (2) INCREASING AVAILABLE MANPOWER IN THIS FIELD. CONTENT AND FORMAT FOR THE MATERIALS WERE PLANNED JOINTLY BY A COMMITTEE OF REPRESENTATIVES FROM INDUSTRY, FROM THE U. S. ATOMIC ENERGY COMMISSION, AND THE U. S. OFFICE OF EDUCATION. THERE ARE THIRTEEN LESSON PLANS WHICH FOLLOW THE ORGANIZATION--(1) TIME REQUIREMENTS, (2) OBJECTIVES, (3) TEACHING AIDS, (4) REFERENCES, AND (5) LESSON INTRODUCTION AND OUTLINE. THE LESSONS INCLUDE (1) STRUCTURE OF MATTER AND NATURE OF RADIATION, (2) NUCLEAR REACTIONS AND RADIOISOTOPES, (3) RADIATION EXPOSURE, (4) RADIATION ATTENUATION, (5) RADIATION ABSORPTION, (6) DETECTION AND MEASUREMENT, (7) PHYSIOLOGICAL EFFECTS OF RADIATION, (8) INTRODUCTION TO RADIOGRAPHY, (9) ELEMENTS OF RADIOGRAPHY, (10) RADIOGRAPHIC FILM, (11) RADIOGRAPHIC TECHNIQUES, (12) RADIOGRAPH INTERPRETATION, AND (13) GOVERNMENT REGULATIONS AND LICENSING. AN APPENDIX INCLUDES A SUGGESTED PATTERN FOR EXAMINATIONS. (DH)

ED020902

U.S. DEPARTMENT OF HEALTH, EDUCATION & WELFARE
OFFICE OF EDUCATION

THIS DOCUMENT HAS BEEN REPRODUCED EXACTLY AS RECEIVED FROM THE
PERSON OR ORGANIZATION ORIGINATING IT. POINTS OF VIEW OR OPINIONS
STATED DO NOT NECESSARILY REPRESENT OFFICIAL OFFICE OF EDUCATION
POSITION OR POLICY.

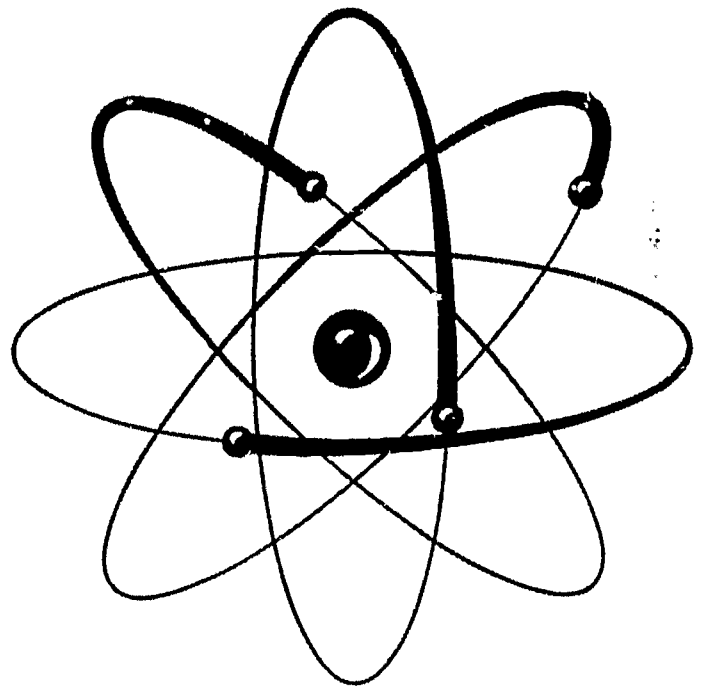

**INDUSTRIAL
RADIOGRAPHY
Student Guide
and
Laboratory Exercises**

SF 004 884

DISCRIMINATION PROHIBITED—

Title VI of the Civil Rights Act of 1964 states "No person in the United States shall on the ground of race, color, or national origin, be excluded from participation in, be denied the benefits of, or be subjected to discrimination under any program or activity receiving Federal financial assistance." Therefore, any program or activity making use of this publication and/or receiving financial assistance from the Department of Health, Education, and Welfare must be operated in compliance with this law.

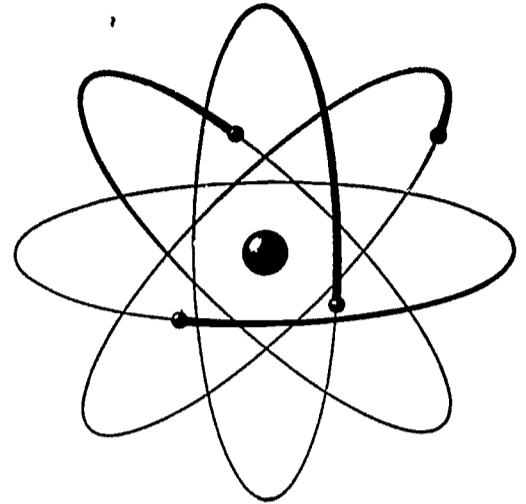

INDUSTRIAL RADIOGRAPHY Student Guide and Laboratory Exercises

Developed jointly by the Division of Vocational and Technical Education of the U.S. Office of Education and the Division of Nuclear Education and Training, U.S. Atomic Energy Commission.

Developed and first published pursuant to a contract with the U.S. Atomic Energy Commission by Harry D. Richardson.

U.S. ATOMIC ENERGY COMMISSION
GLENN T. SEABORG, *Chairman*
Robert E. Hollingsworth, *General Manager*

U.S. DEPARTMENT OF
HEALTH, EDUCATION, AND WELFARE
JOHN W. GARDNER, *Secretary*
Office of Education
HAROLD HOWE II, *Commissioner*

Superintendent of Documents Catalog No. FS 5.284:84035

U.S. GOVERNMENT PRINTING OFFICE
WASHINGTON : 1968

For sale by the Superintendent of Documents, U.S. Government Printing Office
Washington, D.C., 20402 - Price 55 cents

Foreword

Competent radiography technicians must first have the ability to select the most appropriate technique and method for making a specific radiograph. This requires knowledge of radiation physics and of the operating characteristics of the equipment. After exposing and preparing the radiographs, the technician must then be able to interpret the images appearing on them. In addition to the knowledge and skills referred to above, he must understand metal manufacturing and fabricating processes. More specifically, he must know what discontinuities (defects) are revealed by radiography.

No industrial processes and materials are perfect. The radiographer's work is not complete until interpretation of the radiograph determines that the specimen is acceptable, is to be rejected, or designated for repair and retesting.

Long years of shop experience and continued study are required to train a competent radiographer. This 80-hour program provides the trainee with only the most basic knowledge and skills required and he will achieve an understanding of only the basic principles involved. Using these fundamentals, he can further develop his knowledge and skills through shop and field experiences. New developments in equipment and processes are continuously being made. By further study of the current information being published, the studious technician can improve himself and keep up to date with new developments.

The *Student Guide* part of this publication has been developed to assist the trainee in studying the materials assigned in the *Industrial Radiography—Manual*. After reading the assignments in the *Manual*, the questions in the lessons in the *Study Guide* should be answered. The lessons should be submitted to the instructor for corrections, and he will return them at the next class session to discuss and clarify items not fully understood. In the *Laboratory Exercises* part of this publication, the trainee is provided with the opportunity to study and observe personally many of the principles required in acceptable industrial radiography. The patterns of study, classroom lecture and discussion, and laboratory participation have proven to be effective learning experiences.

To assure continued technical development, the trainee is encouraged to obtain copies of the materials listed in the bibliography in the *Industrial Radiography—Manual* for additional and more detailed information. A subscription to the journal entitled *Materials Evaluation* published by the Society for Nondestructive Testing is recommended because it includes information which is useful to radiographers.

In addition to this publication the material prepared and coordinated for this course includes*:

Industrial Radiography—Manual
Industrial Radiography—Instructor's Guide

The need for this course was identified by officials in the U.S. Atomic Energy Commission. The Commission's first concern was to eliminate overexposures to workers engaged in radiography. A second interest was to increase the trained manpower in this expanding field. Content and format for the course were identified by a committee of industry representatives working with representatives of the U.S. Atomic Energy Commission and the U.S. Office of Education, Division of Vocational and Technical Education.

The writing of the manual was performed by Harry D. Richardson, Louisiana State University, under contractual arrangements with the Division of Nuclear Education and Training, U.S. Atomic Energy Commission.

GRANT VENN
*Associate Commissioner for Adult,
Vocational, and Library Programs*

RUSSELL S. POOR
*Director, Division of
Nuclear Education and Training*

*Manual, *Industrial Radiography*, OE-84036, available from Superintendent of Documents, U.S. Government Printing Office, Washington, D.C. 20402, price \$1.25.

Instructor's Guide, *Industrial Radiography*, OE-84034, available from Superintendent of Documents, U.S. Government Printing Office, Washington, D.C. 20402, price 40 cents.

Contents

	<i>Page</i>
FOREWORD	iii
Part One—Student Guide	
1. The Structure of Matter and Radiation	1
2. Nuclear Reactions and Radioisotopes	4
3. The Nature and Consequences of Radiation Exposure	7
4. Radiation Attenuation	9
5. Absorption of Radiation	11
6. Radiation Detection and Measurement	13
7. The Effect of Radiation on the Organs and Tissues of the Body ..	15
8. Introduction to Radiography	17
9. Elements of Radiography	18
10. Radiographic Film	20
11. Radiography Techniques	22
12. Interpretation of Radiographs	24
13. Government Licensing, Health and Transportation Regulations for Radiography	26
Part Two—Laboratory Exercises	
INTRODUCTION	29
LABORATORY CLASS ORGANIZATION PLAN	29
1. Inverse Square Law	33
2. Radioisotope Source Calibration	37
3. Survey Meter Calibration	41
4. Radiation Absorption	45
5. Radiation Scattering	49
6. X-ray Machine Emission Rate	53
7. Darkroom Procedures	57
8. Darkroom Procedures	59
9. Gamma Ray Exposure Calculations	63
10. X-ray Exposure Calculations	67
11. Effect of Graininess	69
12. Welded Pipe Radiography	73
13. Panoramic Exposures	77
14. Radiographing Specimens Having High Subject Contrast	79
15. Leak Testing Sealed Sources	81
16. Laboratory Test	85
APPENDIX A. Source Utilization Record	86
APPENDIX B. Training Program Schedule	87

Part One—Student Guide

The Structure Of Matter And Radiation

Name _____

Date _____

Grade _____

OBJECTIVES:

1. To learn the basic concepts concerning the structure of matter.
2. To develop an understanding of radioactivity and radiation.
3. To secure information about certain kinds of radiation machines.

REFERENCE:

Industrial Radiography Manual, Chapters 1 and 2.

QUESTIONS:

I. Answer the following questions as briefly as possible:

1. How can it be determined that a substance is made up of tiny particles?
2. How may the atom be compared with the solar system?
3. Using data from the Periodic Table of Elements, Table 1.1, illustrate a low mass atom showing protons, neutrons and electrons.
4. Why is the nucleus of an atom of interest to the physicist?
5. How do isotopes of an element differ?

6. Describe an alpha particle.

7. How does electromagnetic radiation differ from particle radiation?

8. State several characteristics of gamma radiation.

9. Name several kinds of electromagnetic waves found in the electromagnetic spectrum.

10. Select a type of radiation machine and describe its characteristics.

II. In the following statements, circle the "T" if the statement is true, circle the "F" if the statement is false:

- T F 1. Matter is composed mainly of empty space.
- T F 2. Atoms making up a compound always combine in the same ratio by weight.
- T F 3. If the number of neutrons in the nuclei of atoms is changed the result is a new element.
- T F 4. The number of electrons in orbit about the nucleus of an atom equals the number of protons in the nucleus.
- T F 5. Most isotopes are not radioactive.
- T F 6. Beta rays are really high speed photons of light.
- T F 7. Electromagnetic waves travel at the speed of light.
- T F 8. An electron has a unit negative charge.
- T F 9. Alpha particles and helium atoms are identical.
- T F 10. Gamma rays and X-rays primarily differ in their origin.

III. Complete the following statements by adding the proper word or words.

- 1. The smallest particles of elements are called _____.
- 2. Substances which are not elements are called _____.
- 3. Water may be broken down to its components _____ and _____.
- 4. The weight of one atom of _____ has been arbitrarily set at 16.0000.
- 5. X-rays were discovered by _____.
- 6. Two main types of radiation are _____ and _____.
- 7. Most X-ray tubes must have a _____ filament.
- 8. The betatron uses _____ to accelerate electrons in a circular path.
- 9. Early experiments in atom smashing used _____ from naturally occurring radioactive materials.
- 10. The energy of gamma rays is measured in _____.

IV. Define, identify, or describe the following terms:

1. Element

2. Compound

3. Electron

4. Proton

5. Neutron

6. Positron

7. Atomic number

8. Atomic weight

9. Deuterium

10. Radioactivity

Nuclear Reactions And Radioisotopes

Name _____

Date _____
Grade _____

OBJECTIVES:

1. To learn the basic concepts concerning nuclear reactions.
2. To study basic ideas about the production of isotopes, fission products and activation products.
3. To develop an understanding of the decay of radioactivity.

REFERENCE:

Industrial Radiography Manual, Chapter 3.

QUESTIONS:

I. Answer the following questions as briefly as possible:

1. Why do neutrons make better "bullets" than protons in forming new radioactive isotopes?
2. What prevents radioisotopes from being produced with infinite activity in a reactor?
3. How are radioactive isotopes for radiography now usually obtained?
4. What is the role of the moderator in an atomic reactor?
5. Why do radioactive atoms decay into atoms of more stable elements?

6. Why is U-235 used as fuel in reactors?

7. Why is it advantageous to plot decay curves on semi-log paper?

II. In the following statements circle the "T" if the statement is true, circle the "F" if the statement is false:

- T F 1. In both the fission and fusion processes, mass is lost as energy is given up.
- T F 2. Fusion results when an atom splits into two nearly equal parts.
- T F 3. The most frequently found isotope of uranium is U-235.
- T F 4. The parts of a fissioned U-235 nucleus are very stable.
- T F 5. Radioisotopes of all elements have been obtained.
- T F 6. The first atomic pile was built in Italy.
- T F 7. A reactor is a good source of heat.
- T F 8. The rate of decay of a radioisotope is constantly changing.
- T F 9. Radioisotopes with a short half-life are the most desirable for use in radiography.

III. Complete the following statements by adding the proper word or words:

- 1. Cobalt-59 captures a neutron and becomes _____.
- 2. A self-sustaining fissioning process is called a _____.
- 3. Uranium fission produces particles which are in greatest quantities around isotopes of mass numbers _____ and _____.
- 4. Naturally occurring radioisotopes include _____ and _____.
- 5. Early production of radioisotopes usually made use of _____ to shoot "bullets" at elements.
- 6. Two commonly used radioactive isotopes in radiography are _____ and _____.
- 7. The unit of measure of the activity of a radioisotope is called a _____.
- 8. The nuclei of radioactive atoms are _____.
- 9. The naturally occurring radioactive elements are mostly at the _____ end of the Periodic Table of Elements.
- 10. Cobalt-60 has a half-life of _____ years.

IV. Define, identify, or describe the following terms:

- 1. Fission
- 2. Fusion
- 3. Curie
- 4. Atomic reactor
- 5. Millicurie
- 6. Decay scheme

7. Half-life

8. Daughter products

V. On Cartesian coordinates and on semi-log coordinates, plot the decay curves for 32 curies of Co-60.

The Nature And Consequences Of Radiation Exposure

Name _____

Date _____

Grade _____

OBJECTIVES:

1. To inform radiography students that the risks of radiation exposure are similar to many other risks which they face daily and are not to be unduly feared on the one hand or taken too lightly on the other.
2. To acquaint radiography students with the standard measurement units of radiation doses.
3. To acquaint radiography students with permissible radiation exposures and inform them how these standards relate to personnel monitoring.
4. To inform radiography students about additional aspects of personnel monitoring, including physical examinations, instrumentation and contamination.

REFERENCE:

Industrial Radiography Manual, Chapter 6.

QUESTIONS:

I. Answer the following questions as briefly as possible:

1. State briefly the philosophy of radiation risk evaluation.
2. Name at least three industrial or professional occupations which involve certain calculated risks.
3. List three sources of natural background radiation.
4. Give an example of a desirable and an undesirable application of X-ray or other type of penetrating radiation.
5. Name four sources of information which have aided scientists in determining the effect of radiation on man.

II. In the following statements, circle the "T" if the statement is true, circle the "F" if the statement is false:

- T F 1. The nuclear energy industry is the most hazardous industry known to man.
- T F 2. The rem is used to measure radiation absorption in living tissue.
- T F 3. An individual exposed to a mild dose of radiation is likely to suffer permanent injury.
- T F 4. Safety practices in nuclear energy industries are set by their insurance companies.
- T F 5. MPD refers to recommended numerical values of permissible doses of radiation for given installations.
- T F 6. Humans are able to feel radiation when they are exposed to radioactive materials.

III. Complete the following statements by adding the proper word or words.

- 1. The unit of dose measurement for penetrating external radiation is the _____.
- 2. _____ is produced by a massive overdose of a long range highly penetrating type of external radiation to the whole body.
- 3. A lethal dose of radiation will usually range from _____ to _____ r.
- 4. _____ results from radioactive material taken into the body.
- 5. According to Federal regulations, permissible occupational dose to the whole body shall not exceed _____ rem multiplied by the number of years beyond the age of _____.
- 6. A _____ is desirable for persons who work with radioactive materials.

IV. Briefly define, identify, or describe the following terms:

- 1. Radioactive poisoning

- 2. Effective half-life

- 3. RAD

- 4. Fractional Exposure

V. Work the following problem:

- 1. According to the Radiation Banking Concept, how long would it take a man to use up his radiation bank account if he enters radiation work at the age of 22 and uses up 10 rem of exposure per year?

Radiation Attenuation

Name _____

Date _____

Grade _____

OBJECTIVES:

1. To develop understanding and use of the inverse square law.
2. To study factors related to the attenuation of radiation.
3. To present factors affecting radiation exposure.

REFERENCES:

Industrial Radiography Manual, Chapter 4, and Chapter 6, Paragraph 6-3.

QUESTIONS:

I. Answer the following questions as briefly as possible:

1. Explain very generally how radiation may be measured.

2. What is the difference between dose and dose-rate as applied to radiation?

3. Explain the effect of time on radiation exposure.

4. What is meant by dose-rate constants (emissivity) for radioisotopes?

5. Why are dose-rate constants of interest to the radiographer?

II. In the following statements circle the "T" if the statement is true, circle the "F" if the statement is false:

T F 1. Radiation cannot be directly measured.

T F 2. Since the roentgen is a large amount of radiation, the milliroentgen is frequently used.

- T F 3. When distance is tripled the amount of radiation received is decreased six times.
T F 4. The inverse square law applies only to "point" sources of radiation.

III. Complete the following statements by adding the proper word or words:

1. Factors affecting exposure to radiation include _____, _____, and _____.
2. The relations of distance to radiation exposure is given by _____.
3. Ionizing rates are expressed in terms of _____.

IV. Define, identify, or describe the following terms:

1. Roentgen
2. Rem
3. Dose rate

V. Work the following problems:

1. Suppose the emission rate of a source of radiation is 81 roentgens per hour at 1 foot. What is the emission rate at 3 feet?
2. A 15 curie source of Cs-137 is to be used 20 feet from a group of workmen. What dose rate will they receive?
3. In the above example at what distance would the group in problem 2 receive only 1 mr/hr?

Absorption Of Radiation

Name _____

Date _____

Grade _____

OBJECTIVES:

1. To learn the absorption characteristics of various types of radiation.
2. To understand the absorption of gamma rays in shielding.
3. To be familiar with the half-value layer concept.
4. To use the concept of reduction factors.

REFERENCE:

Industrial Radiography Manual, Chapter 4.

QUESTIONS:

I. Answer the following questions as briefly as possible:

1. What is an essential difference in the penetrating powers of alpha and beta rays as compared to gamma rays?

2. What is meant by the term "half-value layer"?

3. The term "reduction factor" refers to what ratio?

4. How are linear absorption coefficients related to half-value thicknesses?

II. In the following statements circle the "T" if the statement is true, circle the "F" if the statement is false:

- T F 1. Electromagnetic radiation is easier to stop with shielding than particle radiation.
- T F 2. Gamma rays can penetrate the most dense materials.
- T F 3. In some situations water is a more desirable shielding material than lead.
- T F 4. Regardless of the thickness of a shield, some gamma radiation will be transmitted through the material.
- T F 5. The reduction factor depends only upon the thickness of the shield.

III. Complete the following statements by adding the proper word or words:

1. The intensity of gamma rays passing through an absorber plotted against the thickness of the absorber results in _____ curve.
2. The absorption formula applies to _____ radiation.
3. Charts showing reduction factors may be useful in _____.

IV. Solve the following problems:

1. Suppose there is a 1.0 Mev source of gamma radiation producing 400 mr/hr at one foot. What will the transmission rate be if a lead shield 1.8 cm thick is imposed between the source and the point of radiation measurement? (Refer to *Manual*, Table 4.2)

2. A 20 curie source of Co-60 is to be used 15 feet from a group of workmen. How thick an iron shield would be needed to reduce the dose-rate received by the workmen to 5 mr/hr? (Use half-layer value.)

3. A Cs-137 source of radiation has an intensity of 3 r/hr at a distance of 20 feet. How much lead shielding would be needed to reduce this to a dose-rate of 5 mr/hr at 20 feet? (Use Reduction Factor.)

Radiation Detection And Measurement

Name _____ Date _____
Grade _____

OBJECTIVES:

1. To develop a basic understanding of radiation detection and measurement.
2. To learn basic concepts of radiation measuring instruments.
3. To familiarize students with the more commonly used radiation measuring instruments required for industrial radiography.

REFERENCE:

Industrial Radiography Manual, Chapter 5.

QUESTIONS:

I. Answer the following questions as briefly as possible:

1. Describe the type of measurement made by a dosimeter.
2. Describe the type of measurement made by a survey meter.
3. Explain why an electroscope type instrument must be charged.
4. On Geiger counters which register both gamma and beta radiation, how is the beta radiation measured?
5. Describe how a film badge works.

6. Explain why the Geiger counter is able to measure extremely small amounts of radiation.

7. List several desirable characteristics of survey meters.

II. In the following statements circle the "T" if the statement is true, circle the "F" if the statement is false:

- T F 1. Man cannot detect gamma radiation with his senses.
T F 2. "Measurement" includes both detecting and measuring an amount of radiation.
T F 3. The roentgen is a small unit of measure for radiation in radiography.
T F 4. A film badge is classified as a survey-type instrument.
T F 5. The electroscope's operation is based upon the ionization of gas in a closed chamber.
T F 6. The film badge is used for gamma radiation only.
T F 7. The Geiger counter gives a rapid measure of radiation intensity.
T F 8. The AEC specifies that instruments used by radiographers measure as high as 1 roentgen/hour.

III. Complete the following statements by adding the proper word or words:

1. Radiation measuring instruments provide either a measurement of _____ or of _____
_____.
2. Almost all radiation detecting devices are based upon _____.
3. Geiger counters are essentially _____ level instruments unless they contain special designs.
4. Ionization chamber instruments are _____ level instruments.
5. Geiger tubes use _____ voltages and _____ gas pressures.
6. Both _____ and _____ may be used to measure beta radiation.

IV. Solve the following problems:

1. Suppose it is determined that a 2.1 curie source of Co-60 is available. How far from the source should a meter be placed in order to check the meter at the 500 mr/hr point?

2. Suppose a pocket dosimeter is charged to read 5 mr. After the dosimeter is exposed to a Co-60 source for 5 minutes at a distance of 4 feet, it reads 87 mr. (a) How many millicuries of Co-60 does the source contain? (b) Plot a calibration curve for the source using May 14, 1959 as the calibration date. (c) What will be the source activity on February 3, 1967?

The Effect Of Radiation On The Organs And Tissues Of The Body

Name _____ Date _____
Grade _____

OBJECTIVES:

1. To acquaint the radiography student with the effect of radiation on living matter.
2. To inform radiography students of the relative sensitivity of various body cells to radiation.
3. To develop an understanding of the types of biological effects of radiation and the factors related to these effects.
4. To acquaint the radiography student with the specific effect of radiation on the various organs and tissues of the body.
5. To familiarize radiography students with the genetic effects of radiation and the effect of radiation on the life span.

REFERENCES:

Industrial Radiography Manual, Chapter 7.

QUESTIONS:

I. Answer the following questions as briefly as possible:

1. How does radiation affect the living organism?

2. List five factors which are related to the radiation effects experienced by individuals.

3. In what ways may the genetic effects of radiation be measured?

4. List three of the most critical organs and tissues of the body which are highly sensitive to radiation.

II. In the following statements, circle the "T" if the statement is true, circle the "F" if the statement is false:

T F 1. Mature body cells are more susceptible to radiation injury than immature cells.

T F 2. Bone and nerve cells are highly radiosensitive.

- T F 3. Radiation damage to the endocrine system makes the body more susceptible to heat and cold injury and to resultant infection.
- T F 4. Experiments with animals indicate radiation has no effect on the life span.
- T F 5. The genetic effects of radiation are well documented and it is possible to predict such effects with great accuracy.
- T F 6. It is highly unlikely that sexual impotency can result under modern conditions of occupational exposure to radiation.

III. Complete the following statements by addition of the proper word or words:

1. _____ are the fundamental unit of structure of all living organisms.
2. The _____ cells are the most sensitive to radiation.
3. Radiation can affect the eye by promoting the development of _____.
4. The lungs are more susceptible to radiation injury from _____ sources.

IV. Briefly define, identify, or describe the following terms:

1. Mitosis.
2. Radiosensitivity.
3. Mutations.

Introduction To Radiography

Name _____

Date _____

Grade _____

OBJECTIVES:

1. To introduce the student to the process of radiography.
2. To acquaint the student with the procedures required in the making of an industrial radiograph.
3. To inform students of the industrial applications of radiography.
4. To introduce certain terms and topics of importance to industrial radiography.

REFERENCE:

Industrial Radiography Manual, Chapter 8.

QUESTIONS:

I. Answer the following questions as briefly as possible:

1. Describe how a radiograph is made.

2. List several industrial applications of radiography.

II. In the following statements, circle the "T" if the statement is true, circle the "F" if the statement is false:

- T F 1. Radiation was discovered by the Curies in France in the early 1900's.
T F 2. Radiation proceeds in a straight line from the "source" to the object.
T F 3. Gas porosity in castings cannot be detected by radiography.
T F 4. The darkening of the radiograph is referred to as density.

III. Complete the following statements by adding the proper word or words:

1. Differences in density from one area to another on a radiograph are called _____.
2. Radiography is called a _____ method of testing.
3. Sharpness of outline in the image on a radiograph is called _____.

IV. Briefly define, identify, or describe the following terms:

1. Scatter.

2. Radiographic screens.

3. Roentgen.

Elements Of Radiography

Name _____

Date _____

Grade _____

OBJECTIVES:

1. To acquaint the student with the production of and characteristics of X-radiation.
2. To inform the student of the characteristics of gamma ray sources.
3. To develop a knowledge of the encapsulation of gamma ray sources.
4. To teach the student the geometric principles which apply to shadow formation.

REFERENCE:

Industrial Radiography Manual, Chapter 9.

QUESTIONS:

I. Answer the following questions as briefly as possible:

1. Describe how X-rays of relatively low voltage (below 400 kv) are produced.
2. What is meant by a broad energy spectrum?
3. List the criteria which must be considered in the selection of materials and designs for capsules which are to contain radioactive materials.
4. Give the reasons why object images (shadows) may be distorted in a given radiograph.
5. What is scattered radiation?

II. In the following statements, circle the "T" if the statement is true, circle the "F" if the statement is false:

- T F 1. In an X-ray tube, the amount of tube current is controlled by regulating the heating current applied to the filament.
- T F 2. Radium-226 is one of the most abundant fission products.
- T F 3. Cobalt-60 has a half-life of 75 years.
- T F 4. Radioisotopes emit discrete wave length photons rather than a continuous spectrum.
- T F 5. The radiation beams used in radiography behave much like sound waves.
- T F 6. In order to minimize geometrical unsharpness, the specimen being radiographed should be as close to the film as possible.

III. Complete the following statements by adding the proper word or words:

1. _____ is one of the best ways of sealing capsules containing gamma ray sources.
2. After leak testing, the source exterior (capsules) must be decontaminated so that no more than _____ of removable contamination is present.
3. The sharpness of a radiation shadow depends upon _____, _____, and _____.
4. High energy radiation should be used to radiograph _____ specimens.

IV. Define, identify, or describe the following terms:

1. Double encapsulation
2. Backscatter
3. Leak test
4. Geometric unsharpness
5. Undercut.

Radiographic Film

Name _____

Date _____

Grade _____

OBJECTIVES:

1. To teach the students the characteristics of film used for industrial radiography.
2. To acquaint students with the procedures for determining the films best suited for particular operations.
3. To inform students of the requirements and precautions for each step of film processing.
4. To introduce students to the type of facilities needed for film processing.

REFERENCE :

Industrial Radiography Manual, Chapter 10.

QUESTIONS:

I. Answer the following questions as briefly as possible:

1. What is meant by the term "graininess"?
2. Explain the value of a characteristic curve.
3. What advantage does a lead foil screen have over a fluorescent screen?
4. What factors should be considered in the construction of a darkroom?
5. Explain what is meant by the time-temperature system.

II. In the following statements, circle the "T" if the statement is true, circle the "F" if the statement is false:

- T F 1. A combination of subject contrast and film contrast determines radiographic contrast.
T F 2. Fast film has the better contrast and graininess qualities.
T F 3. Developing solutions have the ability to reduce the silver bromide crystals on the exposed part of the film.
T F 4. It is recommended that the radiographer never use commercially prepared developers in film processing.
T F 5. Longer developing time is likely to produce chemical fog which will increase contrast.
T F 6. Water temperature is not critical in the film washing process.

III. Complete the following statements by adding the proper word or words:

1. The gelatin and crystal mixture which coats the plastic base of a film is called an _____.
2. Film contrast is best described by the _____.
3. A _____ is used to remove the unexposed silver bromide without changing the silver deposits on exposed film.
4. _____ is defined as the product of the radiation intensity reaching the film and the radiation exposure time.

IV. Define, identify, or describe the following terms:

1. H & D curve

2. $D = \log_{10} \frac{I_0}{I}$

3. Developing

4. Fixation

5. Safelight

Radiography Techniques

Name _____ Date _____
Grade _____

OBJECTIVES:

1. To inform students of practical guides for X and gamma radiography exposure arrangements.
2. To teach students methods for calculating exposure time.
3. To present principles for selecting practical radiography techniques.
4. To study causes and corrections of unsatisfactory radiographs.

REFERENCE:

Industrial Radiography Manual, Chapter 11.

QUESTIONS:

I. Fill in the blanks in the following statements:

1. The two most important film processing solutions are _____ and _____.
2. S.F.D. should be equal to or greater than _____.
3. Radiographic contrast is related to _____ contrast and _____ contrast.

II. Define or identify the following:

1. Source (or target) size
2. Emissivity
3. H & D curve
4. Masks and diaphragms
5. Panoramic exposures

III. Answer the following:

1. What is S.E.T.?

2. Describe the technique for radiographing an "orange peel" welded hemisphere.

3. What are the causes of low radiographic contrast?

4. Why does an X-ray beam cause more scatter than a gamma ray beam?

5. What causes fog?

IV. Work the following problems. (Select the appropriate film, density, film factor, s.f.d., etc.)

1. A steel specimen is $\frac{3}{4}$ " thick, 8" long, and 12" wide. Sketch the radiographic arrangement. Calculate the exposure time.

2. An aluminum specimen is 3" thick, 4" wide, and 15" long. Sketch the radiographic arrangement. Calculate the exposure time.

3. A soft aluminum specimen $\frac{1}{2}$ " thick in one area and 2" thick in another area is to be radiographed. It is 10" wide x 12" long. A good quality radiograph is desired. Select the techniques and calculate the exposure time.

Interpretation Of Radiographs

Name _____

Date _____

Grade _____

OBJECTIVES:

1. To inform the student that the radiography process is not complete until analysis and interpretation of the results have been made.
2. To teach the concepts of interpreting test results in their relationship to design and performance of materials and structures.
3. To acquaint the student with the discontinuities likely to be found in welds and castings.
4. To present the general ideas relating to "quality levels" and "acceptance and comparison standards."
5. To study specifications and reference radiographs.
6. To review radiographic codes as they are used in industry.

REFERENCES:

1. *Industrial Radiography Manual*, Chapter 12.
2. Radiographic reference codes and charts prepared by:
 - a) American Society of Mechanical Engineers
 - b) American Society for Testing and Materials
 - c) American Petroleum Institute
 - d) American Welding Society
 - e) U.S. Army Ordnance Department
 - f) U.S. Air Force
 - g) U.S. Navy

QUESTIONS:

I. Answer the following questions as briefly as possible:

1. What is meant by "quality level"?

2. Why is it not necessary for all manufacturing defects to be removed?

3. What is a reference radiograph?

4. What is a penetrometer?

5. What is percent sensitivity?

II. In the following statements, circle the "T" if the statement is true or circle the "F" if the statement is false:

- T F 1. An ASME penetrometer has holes with a one t diameter.
- T F 2. All penetrometers should be made of steel.
- T F 3. Slags are oxides formed in welding.
- T F 4. Small cracks are permissible defects that will not affect the strength of metal specimens.
- T F 5. Magnesium castings sometimes contain microshrinkage.

III. Define, identify, or describe the following terms:

1. Hot tears
2. Segregation
3. Cracks
4. Shrinkage cavities
5. Inclusions
6. Cold shuts
7. Porosity
8. Lack of fusion
9. External discontinuities
10. Lack of penetration

Government Licensing, Health And Transportation Regulations For Radiography

Name _____ Date _____
Grade _____

OBJECTIVES:

1. To inform radiography students of the requirements and conditions of licenses for use of byproduct materials.
2. To inform radiography students of the general considerations necessary for protection against radiation hazards.
3. To acquaint radiography students with the precautionary procedures and records, reports and notification procedures required of persons holding licenses to use byproduct materials.
4. To inform students of the qualifications and skills which a radiographer and a radiographer's assistant must possess and to acquaint students with the various types of training programs for radiographers.
5. To inform students of the various government regulatory bodies which govern transportation of radioactive materials and to provide the student with a general knowledge of ICC, CAR, U.S. Postal Service, and U.S. Coast Guard regulations for ordinary shipments of radioactive materials.

REFERENCES:

1. *Industrial Radiography Manual*, Chapter 13.
2. *AEC Licensing Guide for Industrial Radiography*.
3. *Code of Federal Regulations*: Title 10, Parts 20, 30 and 31; Title 49, Parts 71-77; Title 14, Part 49; Title 46, Part 146.
4. *U.S. Postal Manual*.

QUESTIONS:

I. Answer the following questions as briefly as possible:

1. What are the general requirements which must be met for issuance of a specific license to use byproduct materials for radiography?
2. List the operating and emergency procedures which must be prepared for such a license.
3. Describe what is meant by "periodic training" for radiographers.

4. What are the exposure limits permitted radiography personnel working in restricted areas?

5. Describe the color and markings of the radiation symbol.

6. Explain why radiation surveys are required in connection with radiographic operations.

7. What are the allowable radiation intensities around radioisotope storage containers and exposure devices in the "off" position?

8. What are the range and characteristics of survey meters acceptable for radiography?

9. What are the permissible radiation intensities around exposure devices in the "off" position?

- II. In the following statements, circle the "T" if the statement is true; circle the "F" if the statement is false:
- T F 1. When a specific license for use of byproduct material is issued, it is valid for 20 years.
 - T F 2. A person under 18 years of age normally cannot be employed in radiographic operations.
 - T F 3. Radiographers bear direct responsibility for compliance with regulations wherever they do radiography work.
 - T F 4. Packages classified as Group I materials by the ICC require a blue label.
 - T F 5. Radioactive materials which cannot be shipped as first class mail may be sent as second class mail.
 - T F 6. Licensees must not finally dispose of radioactive waste materials without license authority.

- III. Complete the following statements by adding the proper word or words:
1. States which enter into an agreement with the AEC to assume certain regulatory authority over by-product and special nuclear material are known as _____.
 2. A _____ manipulates equipment and material related to radiography under direct supervision only.
 3. Accidents and violations of ICC regulations must be reported to the _____ as quickly as possible.
 4. Emergency radiological assistance may be obtained from the _____.
 5. The powers of the AEC to establish regulations and grant licenses are pursuant to the _____ and are published in the *Code of Federal Regulations*.

IV. Define, identify, or describe the following terms:

1. Calendar quarter

2. Occupational dose

3. Person

4. Restricted area

5. Sealed source

6. Personnel monitoring

7. Radiation Safety Officer

Part Two—Laboratory Exercises

Introduction

All radiography technicians in industry must become intimately familiar with radiation sources, the many pieces of apparatus associated with radiography techniques, and the safety measures required to protect himself, other craftsmen and personnel in his area, and the general public. Class lectures and demonstrations serve their purposes in the learning process; however, the student can learn radiography and safety procedures ONLY by actually using equipment, making measurements, and performing the operations himself. A group of laboratory exercises will give every student the opportunity to perform exercises covering principles of radiography and the associated radiation safety techniques.

OBJECTIVES:

1. To observe properties of X and gamma radiation.
2. To study radiation detection and measurement.
3. To perform operations related to radiography, e.g., source calibration, radiation surveys, etc.
4. To perform radiography operations.
5. To learn and perform recommended radiation safety practices related to industrial radiography.

DISCUSSION:

The instructor should organize the class so that each student will have ample opportunity for individual participation. Every student should make all necessary calculations and measurements. Every student should conduct himself in accordance with prescribed safety practices and develop good working habits.

Use of all items listed in the safety kit is most desirable in industrial radiography. Filling in forms similar to the samples is required in some installations. It is good exercise for the student to complete all the forms to assure that he is complying with practices which have proven acceptable and useful in industry.

Printing on only one side of the page in this booklet provides ample space for the student's calculations. The student should be encouraged to make notes in this booklet as he observes operations in the laboratory.

Laboratory Class Organization Plan

Presentation of these laboratory experiments should be coordinated with the lecture material taken from the *Industrial Radiography Manual* and work sheets in the *Student Guide*. Eighty hours of classroom lectures, problem sessions, and laboratory exercises are outlined in Appendix B (*Manual*).

The laboratory classes should give the trainee experiences similar to radiography operations in industry. Each student must be given a copy of this book for his own use. After each laboratory exercise is completed, including calculations, sketches, answering questions, etc., the instructor shall review each student's work and insert a grade in the appropriate space. The instructor should discuss deficiencies with the student.

Introductory material at the first laboratory session should follow the guidelines in paragraph 13-6.5*:

- (1) Inform every individual working in restricted areas of all radiation hazards present.
- (2) Instruct all such individuals in the necessary safety practices and procedures for the types of hazards present.

*Paragraph and figure numbers refer to the *Industrial Radiography Manual*.

In a conspicuous place in the laboratory, for the student's observation, post the following:

- (1) Current copies of the AEC regulations relating to standards for protection against radiation.
- (2) A copy of the radiography license.
- (3) Operating procedures applying to the work under the licensee.
- (4) Figure 13.8 Regional Operations Office Locations.

(If it is impractical to post the documents the student should be told the location of the documents for his individual attention.)

Surveys are required in several experiments. These surveys should be done in accordance with paragraph 13-6.1.

Personnel monitoring for industrial radiography technicians is mandatory. Both dosimeters and film badges are required. Records of exposure history and daily radiation dosage will be recorded on Forms AEC-4 and AEC-5 (Figures 13-2 and 13-3).

Caution signs, labels, and signals will be used as described in paragraph 13-6.4.

Source security will be maintained in accordance with paragraph 13-6.7.

Source utilization records must be prepared by each student for each experiment requiring sources. A form for this is in Appendix A of this book.

As a portion of the training program, each student will be shown the laboratory's records and instructed in their preparation:

- (1) Records of receipt and shipment of sources.
- (2) Records of surveys which show locations of sources, radiation field intensities and protective measures which safeguard individuals.
- (3) Records of quarterly radioisotope inventories.
- (4) Records of leak tests.

All radiography sources emit high intensity radiation which can be a personnel safety hazard unless proper safeguards are used. For these laboratory exercises a group of devices has been selected and listed as a *Safety Kit*. This equipment is required to assure that proper radiation measurements and safety conditions can be established and maintained during radiographic operations. Instruments must be in working condition and properly calibrated. **IF THE INSTRUMENTS ARE NOT WORKING OR NOT CALIBRATED, THE SOURCE MUST NOT BE USED UNTIL SUITABLE INSTRUMENTS ARE AVAILABLE.**

The safety kit includes:

1. Dosimeter for each person participating in the exercise.
2. Dosimeter charger.
3. Film badge for each person participating in the exercise.
4. Survey meter (minimum range 0-1,000 mr/hr for isotope radiography sources).
5. Signs
 - a. Radioactive Materials
 - b. Radiation Area
 - c. High Radiation Area
6. Suitable barriers or rope to restrain personnel from entering radiation areas.
7. Alarm (lights or noise maker) actuated by radiation. (This item is desirable but not mandatory.)

A radiation safety program will be organized and conducted for the laboratory exercises. This program shall be similar to radiation safety procedures required for industrial radiography operations.

Chapter 13 of the *Industrial Radiography Manual* and the *AEC Licensing Guide-Industrial Radiography* provide the information necessary for acceptable personnel protection.

Inverse Square Law

Student Name _____

Date _____

Grade _____

OBJECTIVES:

- a. To measure gamma radiation intensities at several distances from a calibrated source.
- b. To compare measured intensities to calculated intensities.

APPARATUS:

1. Calibrated gamma source (suggested convenient activity: 2 c Co-60, 7 c Cs-137, 5 c Ir-192).
2. Stop watch
3. Tape measure
4. Six dosimeters and charger
5. Safety kit.

PROCEDURE:

1. Charge six dosimeters to values near zero. Record each dosimeter scale reading on the data sheet as "Beginning of Exposure."
2. Place two dosimeters at each distance 3 ft., 5 ft., and 6 ft.
3. Using the source decay curve, calculate the exposure time to give approximately 90% full scale reading on the dosimeter placed 3 ft. from the source.
4. Place rope barriers and signs to restrain personnel from entering excessively high radiation fields.
5. Expose the source to the dosimeters for the time calculated in step 3.
6. Survey the area during the exposure. Make a sketch on the data sheet of the general layout. Record radiation intensities which can be used to determine personnel exposures at several locations. Mark on the sketch the locations at which the radiation measurements were made.
7. Read the dosimeters and record the scale readings on the data sheet as "End of Exposure."
8. Secure the source and return all apparatus to the proper storage locations.
9. Answer the questions at the end of this exercise.

QUESTIONS:

1. Why do dosimeters placed at the same distance usually not give the same reading?

2. Which dosimeters probably give the more reliable values?

3. For at least two positions outside the rope barrier (one shielded and one unshielded) determine how long a person could be exposed without receiving more than 100 mr.

DATA SHEET
Laboratory Exercise 1

Col. 1		Col. 2	Col. 3	Col. 4	Col. 5	Col. 6	Col. 7
Dosimeter Number		End of Exposure mr	Beginning of Exposure mr	Difference in Dosimeter Readings mr	Exposure Time minutes	Radiation Intensity $\frac{\text{Col. 4} \times 60}{\text{Col. 5}} =$ mr/hr	Calculated* Intensities mr/hr
3 ft.	1						
	2						
5 ft.	3						
	4						
6 ft.	5						
	6						

*Record values calculated from data on the source decay curve.

SKETCH

Radioisotope Source Calibration

Student Name _____

Date _____

Grade _____

OBJECTIVES:

1. To calibrate a gamma radiography source using apparatus available to a radiographer.
2. To plot a decay curve for the calibrated source.

APPARATUS:

1. Gamma source in an exposure device.
2. Stop watch.
3. Tape measure.
4. Two dosimeters and charger.
5. Safety kit.

PROCEDURE:

(It is necessary that the radiographer know which radioisotope is to be used because he will probably not have facilities for identifying the radioisotope.)

1. Charge two dosimeters near zero and record their scale readings as "Beginning of Exposure."
2. Place these dosimeters at a convenient distance from the source, e.g., 8 feet.
3. Place rope barriers and signs to restrain personnel from overexposure to high intensity radiation.
4. Expose the dosimeters to the source for a convenient time, e.g., 6 minutes.
5. Survey the area during the exposure. Make a sketch on the data sheet of the general layout and record radiation intensities which can be used to determine personnel exposures at several locations.
6. Read the dosimeters and record the scale readings on the data sheet as "End of Exposure." (If the dosimeters are discharged off scale the experiment must be repeated. Use shorter exposure time or longer source to film distance.)
7. Secure the source and return all apparatus to the proper locations.
8. Make a survey to assure the source is properly shielded.
9. Make the calculations indicated on the data sheet. Plot decay curves for this source on rectangular coordinate paper and on semi-logarithmic coordinate paper. (Be sure to properly identify the source on the curve sheets by noting the radioisotope, source serial number, and source manufacturer.)
10. Answer the questions at the end of this exercise.

QUESTIONS:

1. Why should a survey be made after every exposure?

2. Why should a radiographer use dosimeters instead of a survey meter for calibrating a source?

3. Why were two dosimeters used? If these had different readings, which one probably is more accurate?

4. How much variation in source calibration can be accepted for radiography sources? Explain why such a large variation is acceptable.

5. State which curve you prefer—rectangular or semi-log coordinate. Explain why you made this selection.

DATA SHEET
Laboratory Exercise 2

Col. 1	Col. 2	Col. 3	Col. 4	Col. 5	Col. 6
Dosimeter Number	End of Exposure	Beginning of Exposure	Difference in Dosimeter Readings	Exposure Time	Radiation Intensity $\frac{\text{Col. 4} \times 60}{\text{Col. 5}} =$
	mr	mr	mr	minutes	mr/hr
1					
2					

Calculations:

- Using the inverse square law, determine the intensity, I_0 , at 1 ft. from the source.
- Determine the source activity, A , in curies.

$$A = I_0 \div \text{Emissivity of the Isotope}$$

SKETCH

Survey Meter Calibration

Student Name _____

Date _____

Grade _____

OBJECTIVES:

1. To calibrate a gamma survey meter using apparatus available to a radiographer.
2. To initiate use of an instrument calibration log.

APPARATUS:

1. Calibrated gamma source in an exposure device.
2. Stop watch.
3. Tape measure.
4. Survey meter to be calibrated.
5. Safety kit.

PROCEDURE:

1. Determine the scales on the instrument to be calibrated (e.g., 0-20, 0-200, and 0-2,000 mr/hr).
2. Determine the gamma source activity from the decay curve.
3. Calculate the distances from the source at which the field intensity will be $\frac{3}{4}$ of full scale for each range. (Three calculations will determine three distances.)
4. Place rope barriers and signs to restrain personnel from radiation so they will not receive high exposure rates.
5. Survey the area during the exposures. Make a sketch of the general layout and record radiation intensities which can be used to determine personnel exposures at several locations.
 - a. Adjust the instrument to one of its ranges.
 - b. Place the instrument at each calculated distance, expose the source, read the instrument, and record the values on the data sheet.
6. Secure the source and return all apparatus to the proper locations.
7. Answer the questions at the end of this exercise.

QUESTIONS:

1. What degree of accuracy should be expected from gamma survey meters?

2. What should be done if the instrument does not register within the accuracy expected?

3. Give some rules for using gamma survey meters.

4. What calibration frequency does AEC require?

5. How can a radiographer check instrument operation frequently during daily operations?

Radiation Absorption

Student Name _____

Date _____

Grade _____

OBJECTIVE:

To demonstrate radiation absorption using:

- a. Absorbers having different densities
- b. Sources having different energies.

APPARATUS:

1. Radiation sources:
 - a. Co-60
 - b. Ir-192
2. Absorbers:
 - a. Lead—6 @ $\frac{1}{4}$ " x 12", 4 @ $\frac{1}{16}$ " x 12" x 12", and 10 @ 0.005" x 12" x 12"
 - b. Iron—8 @ $\frac{1}{2}$ " x 12" x 12" and 4 @ $\frac{1}{8}$ " x 12" x 12"
 - c. Concrete (150#/cu. ft.)—6 @ 2" x 12" x 12"
 - d. Wood (pine or fir)—8 @ 2" x 12" x 12"
3. Survey meter
4. Safety kit

PROCEDURE:

1. Place a rope barrier and signs to restrain personnel during exposures.
2. Set the scale selector to the highest range on a survey meter.
3. According to the sketch, by several trials, locate the Co-60 source, survey meter and one lead absorber so the meter reads almost full scale. (The distance from source to detector can be changed to vary the meter reading.) Record the meter reading on the data sheet.

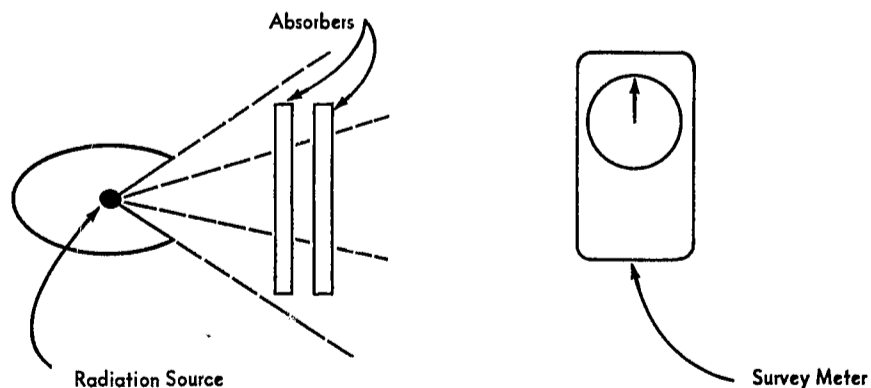

4. Do not change the source to meter distance while making radiation absorption measurements through each group of absorbers. Place the meter in such a position that it can be seen without excessive exposure to the operator.

5. Add a second lead absorber between the source and the meter. Read the meter and record the reading on the data sheet. (To minimize operator exposure, place the source in its "safe" position while manipulating apparatus.)

6. Repeat Step 5 until at least three half value layers have been used.

7. Using the same source, repeat Steps 2 through 5, except a series of data should be recorded for each different type of absorber.

8. On semi-log paper, plot an absorption curve for each different absorber material. Absorber thickness (inches) should be on the linear scale and meter reading (mr/hr) should be on the semi-log scale. For each source, all curves should be plotted on the same curve sheet.

9. Repeat Steps 1 through 8 using the Cs-137, Ir-192, and X-ray sources.

10. Survey the area during exposures. Make a sketch on the data sheet of the general layout and record radiation intensities at several locations.

11. Secure the source and return all apparatus to the proper locations.

12. Answer the questions at the end of this exercise.

QUESTIONS:

1. Within the limits of radiation energies and absorber densities (atomic number, composition) used:

a. Write a statement concerning radiation absorption change versus absorber density change if source energy remains constant.

b. Write a statement concerning radiation absorption change versus energy change if density (atomic number, composition) remains constant.

DATA SHEET
Laboratory Exercise 4

Source	Absorber and Thickness inches	Meter Reading mr/hr		Source	Absorber and Thickness inches	Meter Reading mr/hr

Radiation Scattering

Student Name _____

Date _____

Grade _____

OBJECTIVE:

To demonstrate radiation scattering using:

- a. Sources having different energies.
- b. Scattering materials having different densities.

APPARATUS:

1. Radiation sources:
 - a. Co-60.
 - b. Ir-192.
2. Scattering materials:
 - a. Lead—6 @ $\frac{1}{4}$ " x 12" x 12", 4 @ $\frac{1}{16}$ " x 12" x 12" and 10 @ 0.005" x 12" x 12".
 - b. Iron—8 @ $\frac{1}{2}$ " x 12" x 12" and 4 @ $\frac{1}{8}$ " x 12" x 12".
 - c. Concrete (150#/cu. ft.)—6 @ 2" x 12" x 12".
 - d. Wood (pine or fir)—8 @ 2" x 12" x 12".
3. Survey meter.
4. Safety kit.

PROCEDURE:

1. Place a rope barrier and signs to restrain personnel during exposures.
2. With the source exposed, place the survey meter in a shielded location so there is a low reading on one of the lower meter scales. Record this reading on the data sheet.
3. To minimize operator exposure, place the source in its safe position while manipulating apparatus.
4. Place one piece of wood scattering material approximately 8 inches in from the source and expose the source. Read the meter and record the reading on the data sheet. (Do not change the location of this wood during the exercise.)

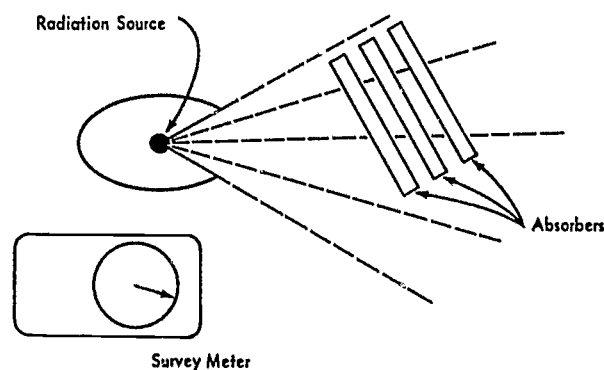

5. Place another piece of wood adjacent to the scattering wood on the side away from the source. Read the meter and record the reading on the data sheet.

6. Repeat Step 5 until there is no change in the meter reading.
7. On semi-log paper, plot a curve to show how scattered radiation varies with thickness of the scattering material. Absorber thickness (inches) should be on the linear scale and meter reading (mr/hr) should be on the log scale.
8. Repeat Steps 4 through 7, except use different scattering material, e.g., lead, iron, or concrete, for each series of readings.
9. For each source, plot all curves on the same data sheet.
10. Survey the area during exposures. Make a sketch on the data sheet of the general layout and record radiation intensities at several locations.
11. Secure the source and return all apparatus to the proper locations.
12. Answer the questions at the end of this exercise.

QUESTIONS:

1. Within the limits of radiation energies and scattering material densities (composition) used:
- a. Write a statement concerning radiation scattering change versus scattering material density if the source energy remains constant.
-
- b. Write a statement concerning radiation scattering change versus source energy change if the scattering material density (composition) remains constant.

DATA SHEET
Laboratory Exercise 5

Source	Scattering Material and Thickness inches	Meter Reading mr/hr	Source	Scattering Material and Thickness inches	Meter Reading mr/hr

X-ray Machine Emission Rate

Student Name _____

Date _____

Grade _____

OBJECTIVES:

1. To measure the energy emission rate from an X-ray machine.
2. To observe the effect of changing kilovoltage on the energy emission rate from an X-ray machine.
3. To observe the effect of changing milliamperage on the energy emission rate from an X-ray machine.
4. To observe the effect of added filters on the energy emission rate from an X-ray machine.

APPARATUS:

1. X-ray machine having 250 kv power supply or higher if available.
2. Survey meter.
3. Filters, lead or copper, 0.005" thick.
4. Safety kit.

PROCEDURE:

1. By "trial and error," place a survey meter in such a location that it can be seen and, also, at such a distance that it will give approximately a maximum scale reading in the beam from the X-ray machine which is being operated at maximum kv and ma. (DO NOT go into the X-ray beam to move the survey meter. Turn off the machine before moving the survey meter.) Do not move the survey meter during the remainder of the experiment.

2. On the data sheet record the source to survey meter distance.

3. Record the survey meter, kv, and ma readings on the data sheet.

4. To observe the effect of changing kilovoltage on the emission rate, change the kv in steps. Be sure the ma is kept at its original value. At each kv step, record kv, ma and survey meter readings on lines 1 through 6 on the data sheet. Plot a curve of emission rate on paper with kv on the horizontal axis and survey meter readings on the vertical axis.

5. To observe the effect of changing ma on the emission rate, set the ma and kv at maximum values. Be sure that the kv is kept at its original value. Reduce the ma in steps. At each ma step record the kv, ma, and survey meter readings on lines 6 through 12 on the data sheet. Plot a curve of emission rate on paper with ma on the horizontal axis and survey meter readings on the vertical axis.

6. To observe the effect of added filters on the energy emission rate from an X-ray machine, set the kv and ma at maximum values. Read and record kv, ma, and survey meter readings on lines 13 through 18. On line 13, record readings with no filter in the X-ray beam. (Be sure the machine is turned off when changing filters.) Add one filter and record the readings on line 14. Add a second filter and record the readings on line 15. Continue this process until 5 filters have been added and the instrument readings are recorded. Plot a curve on paper with filter thickness on the horizontal axis and survey meter reading on the vertical axis.

7. Answer the questions at the end of the experiment.

QUESTIONS:

1. What conclusion can be made concerning the effect of changing kilovoltage on the energy emission rate?
2. What conclusion can be made concerning the effect of changing milliamperage on the energy emission rate?
3. What conclusion can be made concerning the effect of added filtration on the energy emission rate?
4. Why is it sometimes desirable to add filters to an X-ray tube?

DATA SHEET
Laboratory Exercise 6

Distance from target to survey meter _____ inches.

Measurement Number	kv	ma	Survey Meter Reading, mr/hr	
1				
2				
3				
4				
5				
6				
7				
8				
9				
10				
11				
12				Filter Thickness
13				
14				
15				
16				
17				
18				

Darkroom Procedures

Student Name _____

Date _____

Grade _____

OBJECTIVES:

1. To identify and inspect all apparatus and equipment used in the darkroom.
2. To mix chemicals necessary for radiography.
3. To practice darkroom techniques.

APPARATUS:

1. Developing tanks and temperature control system.
2. Dryer
3. Safelights
4. Timer
5. Thermometer
6. Film and film storage bin
7. Film holders and screens
8. Developing hangers
9. Corner cutter
10. Radiographic filing envelopes and storage cabinet.
11. Chemicals for preparing developer, short-stop, fixer, and replenishers.

PROCEDURE:

1. The instructor will identify all the apparatus, explain its operating function, and proper maintenance. Cleanliness should be stressed.
2. Mix developer, short-stop, fixer, and replenisher solutions according to the manufacturer's directions. The student should record in his notebook the information related to time and temperature of the chemical processing recommended by the manufacturer.
3. After instructions concerning handling film, screens, and film holders, each student should remove a box of film from storage, load one film into an exposure holder, and return the film to proper storage.
4. Each student should attach a film to a developing hanger.
5. Remove the film from the hanger, place it in a filing envelope, and file in the storage cabinet. Observe the identification on the envelope.

Darkroom Procedures

Student Name _____

Date _____

Grade _____

OBJECTIVES:

1. To provide experience in processing film.
2. To observe the effect of developing time.

APPARATUS:

1. Darkroom.
2. Developing tanks and chemicals.
3. Film and exposure holders.
4. Specimen to be radiographed.
5. Penetrameters.
6. Lead numbers and letters.
7. Radiation sources.
 - a. X-ray.
 - b. Co-60.
 - c. Cs-137.
 - d. Ir-192.
8. Safety kit.

PROCEDURE:

1. The instructor will divide the class into groups. Each group will be assigned to use a different exposure device.
2. Each group will load four film holders. Use 0.005" lead screens on the front and 0.010" lead screens on the back of the film. All students use the same type film.
3. A specimen or step wedge will be assigned to each group. The instructor will calculate exposure times. (For this experiment every group must use identical specimens.)
4. The instructor will assign lead letters and numbers and penetrameters to be used and demonstrate their placement on the specimen.
5. Each group will expose its four films for the same exposure, specimen arrangement, and distance.
6. Develop the films according to this schedule:
 - a. One film developed for one minute.
 - b. One film developed for eight minutes.
 - c. One film developed for sixteen minutes.
 - d. One film developed for thirty-two minutes.
7. Measure the film density at selected and corresponding areas on the radiographs.
8. Answer the questions at the end of the experiment.

QUESTIONS:

1. What is the effect of developing time on overall film density?

2. What is the effect of developing time on contrast?

3. Can any effects be observed and attributed to different energies emitted from the X-ray, Co-60, and Ir-192 sources?

Gamma Ray Exposure Calculations

Student Name _____ Date _____
Grade _____

OBJECTIVES:

1. To calculate exposure times for gamma ray sources.
2. To observe the effect of varying exposure time on the overall film density.

APPARATUS:

1. Darkroom and its associated apparatus.
2. Gamma ray exposure devices:
 - a. Co-60.
 - b. Cs-137.
 - c. Ir-192.
3. Safety kit.
4. Densitometer.

PROCEDURE:

1. The instructor will divide the class into groups. Each group will be assigned to work with a different radioisotope exposure device and isotope.
2. The instructor will assign a similar specimen or step wedge to each group.
3. Each group will load three film holders. All groups will use the same type film. Use 0.005" front lead screens and 0.010" back lead screens.
4. Using the techniques in Chapter 11 (*Manual*), calculate the exposure time to give H and D density = 1.5 on a selected area of the step wedge.
5. Expose films according to this schedule:
 - a. One film at the time calculated for density = 1.5.
 - b. One film at $\frac{1}{2}$ the time calculated for density = 1.5.
 - c. One film at 2 times that calculated for density = 1.5.
6. Process the films.
7. Measure the film density at selected and corresponding areas on the radiographs.
8. Answer the questions at the end of the experiment.

QUESTIONS:

1. What is the effect of exposure time on the overall film density?

2. What is effect of exposure time on radiographic contrast?

3. Upon comparing the Co-60, Cs-137, and Ir-192 exposed films, what conclusion can be drawn concerning contrast? (Density measurements, for this comparison, should be made on radiographs, taken with each source, that have approximately the same density for a particular thickness.)

X-ray Exposure Calculations

Student Name _____

Date _____

Grade _____

OBJECTIVES:

1. To calculate exposure time for different X-ray kilovoltages.
2. To observe the effect of varying film speeds.

APPARATUS:

1. Darkroom and its associated apparatus.
2. X-ray machine and exposure charts.
3. Specimens.
4. Safety kit.

PROCEDURE:

1. The instructor will divide the class into three groups. Each group will be assigned to work with a different type of film.
2. Each group will load three film holders using 0.005" lead screens.
3. The instructor will assign a similar specimen or step wedge to each group.
4. Using the method in Chapter 11 (*Manual*), each group will determine the techniques and expose its three films to attain density = 1.5 for this kv schedule:
 - a. One film exposed at the maximum kv available.
 - b. One film exposed at the minimum kv available.
 - c. One film exposed at the kv midway between *a* and *b*.
5. Process the films.
6. Measure the film density at selected and corresponding areas on the radiographs.
7. Answer the questions at the end of the experiment.

QUESTIONS:

1. What effect can be observed on a selected film type when changing kilovoltage?

2. Upon comparing films having different speeds, what conclusion can be made concerning exposure time and relative costs of radiographs?

3. If the exposure curve sheet was made for 36" s.f.d., what correction is necessary if the radiograph required a 30" s.f.d.?

Effect Of Graininess

Student Name _____

Date _____

Grade _____

OBJECTIVES:

1. To observe the effect of film grain on contrast and definition.
2. To observe the effect of source energy on contrast and definition.

APPARATUS:

1. Darkroom and its associated accessories.
2. Safety kit.
3. Exposure devices:
 - a. X-ray machine
 - b. Co-60
 - c. Cs-137
 - d. Ir-192

PROCEDURE:

1. The instructor will divide the class into three groups.
2. Each group will be assigned to work with a film having different graininess.
3. The instructor will assign similar specimens or a step wedge to each group.
4. Each group will load four films using 0.005" front lead screens and 0.010" back lead screens.
5. Each group will calculate exposure time and expose one film with each source:
 - a. X-ray machine, maximum kv.
 - b. Co-60
 - c. Cs-137
 - d. Ir-192
6. Process the films.
7. Each student should tabulate data from every group.
8. Answer the questions at the end of the experiment.

QUESTIONS:

1. What effect can be observed on each film type when changing sources?

2. What is the relation between speed and grain?

3. How does graininess affect image definition?

4. Under which condition may large grain film be acceptable?

5. Why would very fine grain film be used?

6. What is the cost relationship in using fine grain film versus coarse grain film?

Welded Pipe Radiography

Student Name _____

Date _____

Grade _____

OBJECTIVES:

1. To radiograph small diameter pipe.
2. To radiograph large diameter pipe.

APPARATUS:

1. Darkroom and associated accessories.
2. Radiation sources.
 - a. X-ray
 - b. Co-60
 - c. Cs-137
 - d. Ir-192
3. Safety Kit

PROCEDURE:

1. The instructor will divide the class into small groups.
2. Each group will be assigned to use a different film during this exercise.
3. Refer to the *Manual*, Figure 11.11, for exposure arrangements.
4. Each group will be assigned a specimen made from small diameter welded pipe. Each group will be assigned a specimen made from large diameter welded pipe.
5. Make one exposure for film density = 1.0, one exposure for film density = 2.0, and one exposure for film density = 3.0 for each specimen.
6. Each group will select at least two sources and make radiographs of the welds assigned. (This requires a total of 12 exposure arrangements.)
7. Each student should tabulate data from every group.
8. Answer the questions at the end of the experiment.

QUESTIONS:

1. What comparison can be made concerning radiographic quality using different sources?

2. What difference can be observed in radiographic quality resulting from changing density?

3. Why should the large pipe weld be exposed in sections?

4. Draw a diagram to show the relationship between specimen thickness and s.f.d. required when radiographing small diameter pipe in one or two exposures.

Panoramic Exposures

Student Name _____

Date _____

Grade _____

OBJECTIVE:

1. To present panoramic exposure techniques.

APPARATUS:

1. Darkroom and its associated accessories
2. Exposure devices have 360° beams
3. Safety kit

PROCEDURE:

1. The instructor will divide the class into small groups.
2. Each group will be assigned several specimens and a source emitting a 360° beam. The specimens should not all have the same density or thickness.
3. Each group will select the proper film and setup, calculate exposure time, and then expose and develop the film.
4. Each group must simultaneously expose all of the assigned specimens.
5. Answer the questions at the end of the experiment.

QUESTIONS:

1. For each specimen, what could be done to improve the radiograph quality so smaller discontinuities could be determined?
2. Why was it necessary to use different source to film distances?
3. If different film types were chosen, explain why the films were chosen.

Laboratory Exercise 14

Radiographing Specimens Having High Subject Contrast

Student Name _____

Date _____

Grade _____

OBJECTIVE:

To present techniques for radiographing specimens having high subject contrast.

APPARATUS:

1. Darkroom and its associated accessories
2. Exposure devices
 - a. X-ray
 - b. Co-60
 - c. Cs-137
 - d. Ir-192
3. Safety kit

PROCEDURE:

1. The instructor will divide the class into small groups.
2. A specimen having a large thickness range will be assigned to each group.
3. Each group will select the desired radiation source appropriate to the specimen.
4. Each group will radiograph the specimen in accordance with the techniques for such specimens as discussed in the *Manual*, paragraph 11-3, EXPOSURE ARRANGEMENTS.
5. Answer the questions at the end of the experiment.

QUESTIONS:

1. What are some changes that could be made to improve the radiographs prepared for this experiment?

2. What would be the effect of using high energy versus low energy when radiographing specimens having high subject contrast?

3. What are the advantages and/or disadvantages of using a single exposure technique as compared to a multiple exposure technique?

Leak Testing Sealed Sources

Name _____

Date _____

Grade _____

OBJECTIVE:

To demonstrate and review sealed source leak testing.

APPARATUS:

1. Radioisotope exposure device containing a sealed source.
2. Scaler and Geiger tube.
3. Safety kit.

PROCEDURE AND DISCUSSION:

Paragraph 13-9.3 Leak Testing (*Manual*) states that, as a precautionary measure, it is required that each sealed source be tested for leakage at intervals not to exceed six months. The test must be capable of detecting the presence of 0.005 microcuries of removable contamination on the sealed source.

This leak testing may be performed by the radiographer or the test may be made by some other qualified person. Records of leak tests must (1) identify the source, (2) state the date the test was performed, and (3) state the results of the test.

All radioactive materials used for radiography will have very small pieces flaking off from the pellets. These pieces will also be radioactive since they are the same material as the source. The pieces are so small they will move through any and all openings in the capsule. The active material from a leaking source will migrate and contaminate all surfaces of the source container and also surrounding areas if the leakage is excessive. Submicroscopic quantities of these contaminating pieces can be detected by the methods used in this experiment.

Due to the very high intensity of radiography sources, a severe personnel hazard may result from attempting to directly test the source capsule. It has been found acceptable to test for contamination at the container opening nearest to the source.

Collecting the contamination for evaluation is performed by:

1. Wetting a small cotton swab with a detergent solution or chelating agent.
2. Using the swab, wipe the container surfaces in and/or around the container opening nearest the source.

Evaluation of the contamination on the swab will be demonstrated by the instructor. (This "counting" procedure is beyond the scope of this course, however, it is important that the radiographer know the significance of leak testing. Sometimes this is called "wipe testing.")

Very few radiographers will have equipment for "counting" wipe test swabs. To accomplish the required leak tests it is permissible for the radiographer to use the services of a consultant or testing laboratory. Frequently, a mailing leak test service is used. A laboratory offering this service will mail a leak test kit to the radiographer. A procedure provided with the kit instructs the radiographer:

1. First, use a survey meter to assure the source is adequately shielded.
2. Wet the cotton swab contained in the kit.
3. Using the wet swab, wipe in and/or around the container opening nearest the source.

4. Switch the survey meter to its lowest scale. Place the swab near the most sensitive region of the detector.

5. If a reading is indicated on the survey meter, it is reasonable to assume the source is leaking. Investigation should be made to determine the severity of the contamination. Corrective action should be immediately implemented.

6. **LEAKING SOURCES SHALL NOT BE USED.**

7. If no reading is indicated on the survey meter, it is reasonable to consider that no appreciable amount of contamination is present. Place the swab in the kit and mail it to the service laboratory. (If the leak test indicates zero removable contamination exists, there may be some doubt that the leak test was properly performed.)

8. The laboratory will measure the amount of contamination on the swab.

9. The laboratory will prepare and mail a certificate to the radiographer. This certificate must state the test result in microcuries.

10. A permanent file of the leak test certificates should be kept.

QUESTIONS:

Answer the following questions:

1. Why is leak testing required?

2. Why should records of leak tests be kept for long periods of time?

3. How frequently should leak tests be made?

4. Why is the limit $0.005 \mu\text{c}$ not decreased?

Laboratory Exercise 16

Laboratory Test

Student Name _____

Date _____

Grade _____

OBJECTIVE:

To determine the trainee's ability to work safely and effectively while preparing industrial radiographs.

APPARATUS:

1. Darkroom and its associated apparatus
2. Exposure devices
3. Safety kit

PROCEDURE:

1. The instructor will assign to each trainee at least two specimens requiring different radiography techniques.
2. The student will select the proper source (X-ray or gamma ray) film, and all techniques to safely radiograph the assigned specimens with 2% penetrameter sensitivity.
3. Observations by the instructor on the quality of the radiograph and general workmanship will be determining factors for the student's grade on this test.

APPENDIX A

Source Utilization Record

	Date Used	Signature of Person Using Source	Source and Exposure Device Identification	Location of Source Use	Signature At End of Work Day*
1					
2					
3					
4					
5					
6					
7					
8					
9					
10					
11					
12					
13					
14					
15					
16					
17					
18					
19					
20					

*At the end of each working day it is mandatory that a survey be made to assure the source has been properly secured and is in such condition that personnel in the area cannot be exposed to radiation. The Source Utilization Record must be signed, acknowledging that a satisfactory survey has been made. (If the survey is not satisfactory, it is implied that the radiographer will implement corrective action.)

APPENDIX B

80-Hour Schedule for Radiography Training Program

1-Hour Session Number	1st day	2nd day	3rd Day	4th Day	5th Day	6th Day	7th Day	8th Day	9th Day	10th Day
1	General Instructions	Review SGL-1, 2, 3, 4	Review SGL-5, 6	IGL-9	Review SGL-7, 8, 9, 10	Mid-Term Exam	Review SGL-11	½ of SGL-13	Review SGL-13	LE-15
2	IG-Intro.	LE-1	LE-2	LE-3	LE-7	Mid-Term Exam	LE-10	LE-12	LE-14	LE-16
3	IGL-1	LE-1	LE-2	LE-3	LE-8	IGL-11	LE-10	LE-12	LE-14	LE-16
4	IGL-2	IGL-5	LE-4	IGL-10	LE-8	IGL-11	LE-10	LE-12	LE-14	LE-16
5	IGL-3	IGL-5	LE-4	LE-5	LE-8	LE-9	½ of IGL-13	IGL-12	Review SGL-12	Final Exam
6	IGL-4	IGL-6	LE-4	LE-5	LE-6	LE-9	LE-11	IGL-12	LE-13	Final Exam
7	SGL-1 SGL-2	SGL-5 SGL-6	IGL-7 IGL-8	LE-5	LE-6	LE-9	LE-11	SGL-12	LE-13	Final Exam
8	SGL-3 SGL-4	SGL-5 SGL-6	SGL-7 SGL-8	SGL-9 SGL-10	LE-6	SGL-11	LE-11	SGL-13	LE-13	Final Exam

IGL = Instructor's Guide Lesson

LE = Laboratory Exercise

SGL = Student Guide Lesson

DE-01
GE

**UNITED STATES
GOVERNMENT PRINTING OFFICE**
DIVISION OF PUBLIC DOCUMENTS
WASHINGTON, D.C. 20402
OFFICIAL BUSINESS

**POSTAGE AND FEES PAID
U.S. GOVERNMENT PRINTING OFFICE**

**U.S. DEPARTMENT OF
HEALTH, EDUCATION, AND WELFARE**
Office of Education

● **U.S. ATOMIC ENERGY COMMISSION**
OE-84035