

R E P O R T R E S U M E S

ED 020 680

24

EM 006 672

PROGRAMED INSTRUCTION AND THE DEMONSTRATION METHOD OF
TEACHING AT THE JUNIOR HIGH LEVEL. FINAL REPORT.

BY- CLAWSON, BARBARA SHOFFNER, SARAH M.

NORTH CAROLINA UNIV., GREENSBORO

REPORT NUMBER BR-5-1042

PUB DATE JAN 68

CONTRACT OEC-5-10-041

EDRS PRICE MF-\$1.00 HC-\$8.44 209P.

DESCRIPTORS- *SEWING INSTRUCTION, *TRANSFER OF TRAINING,
*PROGRAMED INSTRUCTION, PROGRAMED MATERIALS, PROGRAMS,
*SECONDARY EDUCATION, *LEARNING PROCESSES, SKILL DEVELOPMENT,
TRAINING, OBSERVATION,

A SELF-INSTRUCTIONAL PROGRAM ON SEWING WAS DEVELOPED AND COMPARED WITH THE TRADITIONAL LABORATORY-DEMONSTRATION METHOD OF TEACHING. THE PROGRAM COMPRISED SECTIONS ON SEWING MACHINES, PATTERNS, AND BLOUSE CONSTRUCTION, AND WAS INTENDED TO ACHIEVE PERFORMANCE OF LABORATORY TASKS, UNDERSTANDING OF THE PROCESSES INVOLVED, AND PREPARATION FOR TRANSFER OF LEARNING TO A NEW TASK. VISUAL AND TACTILE AIDS WERE INCLUDED IN THE PROGRAM, AS WELL AS INSTRUCTIONS AT CERTAIN POINTS FOR THE STUDENT TO ASK THE TEACHER TO CHECK HIS WORK. FIFTY-SEVEN STUDENTS USED THE PROGRAM IN THE FIELD STUDY, AND THEIR PERFORMANCE ON FIVE NORM-REFERENCED TESTS WAS SIGNIFICANTLY BETTER THAN THAT OF CONVENTIONALLY TAUGHT STUDENTS. EVALUATIVE DEVICES USED WERE A ONE HOUR PERFORMANCE TEST, A THREE HOUR PERFORMANCE TEST OF ABILITY TO TRANSFER LEARNING, A RECALL TEST, A TEST FOR APPLICATION OF PRINCIPLES, AND A RATING OF THE BLOUSES CONSTRUCTED. FOLLOWING THE FIELD EXPERIMENT, WHICH INVOLVED SPLIT CLASSES, THE PROGRAM WAS REVISED AND TESTED FOR EFFECTIVENESS IN A NORMAL CLASSROOM OF 35 STUDENTS. PERFORMANCE WAS SUPERIOR TO THAT OF STUDENTS IN TEACHER-TAUGHT SECTIONS OF THE FIELD EXPERIMENT. RESULTS OF THE STUDY INDICATED THAT LEARNING FROM SELF-INSTRUCTIONAL PROGRAMS IS NOT CONFINED TO RECALL OF SPECIFIC RESPONSES, AND THAT PROGRAMS CAN TEACH MOTOR SKILLS. APPENDICES INCLUDE PROGRAM OBJECTIVES, SAMPLE FRAMES, A DESCRIPTIVE LIST OF PANELS AND EXHIBITS IN THE PROGRAM, AND THE EVALUATIVE DEVICES USED. (BB)

BR-5-1042
P.A. 24
A

ED020680

FINAL REPORT
Project No. 5-1042-24
Contract No. OE 5-10-041

06672

PROGRAMED INSTRUCTION AND THE DEMONSTRATION METHOD
OF TEACHING AT THE JUNIOR HIGH SCHOOL LEVEL

January 1968

U.S. DEPARTMENT OF
HEALTH, EDUCATION, AND WELFARE

Office of Education
Bureau of Research

U.S. DEPARTMENT OF HEALTH, EDUCATION & WELFARE
OFFICE OF EDUCATION

THIS DOCUMENT HAS BEEN REPRODUCED EXACTLY AS RECEIVED FROM THE PERSON OR ORGANIZATION ORIGINATING IT. POINTS OF VIEW OR OPINIONS STATED DO NOT NECESSARILY REPRESENT OFFICIAL OFFICE OF EDUCATION POSITION OR POLICY.

PROGRAMED INSTRUCTION AND THE DEMONSTRATION METHOD
OF TEACHING AT THE JUNIOR HIGH SCHOOL LEVEL

Project No. 5-1042
Contract No. OE 5-10-041

Project Director: Hildegarde Johnson

Co-Investigators: Barbara Clawson
Sarah M. Shoffner

January 1968

The research reported herein was performed pursuant to a contract with the Office of Education, U.S. Department of Health, Education, and Welfare. Contractors undertaking such projects under Government sponsorship are encouraged to express freely their professional judgment in the conduct of the project. Points of view or opinions stated do not, therefore, necessarily represent official Office of Education position or policy.

University of North Carolina
at Greensboro

Greensboro, North Carolina

EM 006 672

ACKNOWLEDGMENTS

We are indebted to Alex W. Andres and Margaret C. Samways, American Institutes for Research, for their initial guidance in techniques of program development and for their expert criticisms and suggestions during the preparation of the self-instructional program used in the experiment; to Dr. Dorothy Adkins Wood, the evaluation consultant, for her help during the development of the evaluation devices; to Dr. Darrell Bock, Dr. Lyle V. Jones, and Mr. Steve Zyzanski for the many helpful suggestions they made in regard to the analyses of the data; to Sarah M. Shoffner for the art work; and to Ann S. Smith, the project secretary, for all the tasks she performed so efficiently. We also wish to express appreciation to Dr. Naomi Albanese, dean of the School of Home Economics, for her encouragement and support in securing facilities and resources.

A number of colleagues have been especially helpful in other phases of the research. Dr. Eunice Deemer and Mrs. Helen K. Staley, members of the Clothing and Textiles staff, served as subject-matter consultants. Miss Louise Lowe and Mrs. Rebecca M. Smith reviewed the program at various developmental stages.

The graduate research assistants assigned to the project over the three-year period contributed many ideas, helped in the preparation of materials and assisted in the administration of the tests.

Without the cooperation of the county superintendents, the high school principals, the home economics teachers, and the students involved, the field experiment in this study would have been impossible. In addition, their interest, support, and enthusiasm made it a pleasure to work with them.

Materials and equipment were supplied by the Singer Company, Simplicity Pattern Company, Burlington Industries, and Lily Mills. These materials and equipment were used during the preparation of the experimental materials and during the field experiment.

TABLE OF CONTENTS

	Page
ACKNOWLEDGMENTS.....	ii
LIST OF TABLES.....	vi
LIST OF ILLUSTRATIONS.....	viii
 Chapter	
I. INTRODUCTION.....	1
Problem.....	1
Population for Which Program Was To Be Prepared....	1
Background of Study.....	1
Theoretical Context of the Problem.....	2
Relation of Research Design to That of Other Studies in Which Programs Are Appraised.....	5
II. DEVELOPMENT AND APPRAISAL OF THE SELF-INSTRUCTIONAL PROGRAM.....	7
Program Developed for the Pilot Study.....	7
Training of Programers.....	9
Type of Program Desired.....	9
Development of Objectives.....	10
Appraisal by Consultants.....	12
Student Trial and Revision Cycle.....	13
Description of <u>Sewing Step-by-Step</u>	13
Use of Visual and Tactile Aids.....	14
Group Testing to Determine Error Rate and Time....	17
Informal Appraisal of Affective Concomitants.....	21
III RATIONALE FOR TYPE OF EVALUATION DEVICES DEVELOPED....	22
Norm-Referenced Tests.....	22
Criterion-Referenced Tests.....	22
Preference of Authorities in Programed Instruction for Criterion-Referenced Tests.....	23

Chapter	Page
Comparison of Norm-Referenced and Criterion-Referenced Tests.....	25
Norm-Referenced Tests Used in This Study.....	26
IV. DESIGN AND CONDUCT OF THE FIELD EXPERIMENT.....	37
Experimental Design.....	37
Criterion Variables.....	38
Sampling Plan.....	39
Assignment of Subjects to Sections.....	39
Subjects.....	40
Procedure in Each School.....	42
Time Schedule.....	45
Data Analysis.....	46
V. ANALYSIS OF DATA AND RESULTS.....	47
Multivariate Analysis of Variance.....	47
Analysis of Each Dependent Variable.....	53
Summary and Conclusions.....	67
VI. REVISION OF PROGRAM AND TRIAL IN CLASS OF NORMAL SIZE.....	69
The Revised Program.....	69
Group Test of the Revised Program.....	70
VII. CONCLUSIONS AND IMPLICATIONS.....	74
VIII. SUMMARY.....	76
REFERENCES.....	80
APPENDIX A - Generalizations and Objectives.....	A-1
APPENDIX B - Selected Frames from <u>Sewing Step-by-Step</u>	B-1
APPENDIX C - Description of Panels and Exhibits Accompanying <u>Sewing Step-by-Step</u>	C-1
APPENDIX D - Evaluation Devices Used in Study.....	D-1
One-Hour Performance Test.....	D-1
Three-Hour Performance Test.....	D-6
Recall Test.....	D-12
Application Test.....	D-24

	Page
Blouse Rating Scale.....	D-39
Instructions to the Judges.....	D-53
Sewing Experience Questionnaire.....	D-61
APPENDIX E - Diagram of Blouse Used in Study.....	E-1
APPENDIX F - Information Sheet Given to Teachers.....	F-1

LIST OF TABLES

Table		Page
1	Mean Error Rate for Sections and Sub-Sections of the Program.....	19
2	Time Record for Sections and Sub-Sections of the Program.....	20
3	Number of Students Classified at Each Level on Pre-Experience Questionnaire.....	41
4	Frequency Distribution of Scores on Pre-Test.....	42
5	Mean Vectors for a Two-Way Multivariate Analysis of Variance.....	48
6	Classification of Subjects.....	49
7	Subclass Means.....	51
8	Tests of Significance.....	50
9	Product-Moment Error Correlations for Five Dependent Variables.....	53
10	Analysis of Variance of Scores on One-Hour Performance Test.....	54
11	Mean Scores for Program-Taught and Teacher-Taught Sections on One-Hour Performance Test.....	54
12	t-Test for Difference Between Experimental and Control Groups Within Schools for One-Hour Performance Test.....	56
13	Analysis of Variance Scores on Recall Test.....	57
14	Mean Scores for Program-Taught and Teacher-Taught Sections on the Recall Test.....	57

Table		Page
15	t-Test for Difference Between Experimental and Control Groups Within Schools for Recall Test.....	58
16	Analysis of Variance of Scores on Application Test.....	59
17	Mean Scores for Program-Taught and Teacher-Taught Sections on the Application Test.....	60
18	t-Test for Difference Between Experimental and Control Groups Within Schools for Application Test.....	61
19	Analysis of Variance of Scores on Three-Hour Performance Test.....	62
20	Mean Scores for Program-Taught and Teacher-Taught Sections on Three-Hour Performance Test.....	63
21	t-Test for Difference Between Experimental and Control Groups Within Schools for Three-Hour Performance Test.....	64
22	Analysis of Variance of Scores on Blouses.....	64
23	Mean Scores for Program-Taught and Teacher-Taught Sections on Blouse.....	65
24	t-Test for Difference Between Experimental and Control Groups Within Schools for Blouse.....	67
25	Mean Error Rate for Sections and Sub-Sections of the Revised Program.....	71
26	Comparison of Mean Scores on the Five Evaluation Devices of Students Using the Original and Revised Programs.....	72

LIST OF ILLUSTRATIONS

Figure		Page
1	Selected Frames from <u>Sewing Step-by-Step</u>	15
2	Mean Scores for Program-Taught and Teacher-Taught Sections on the One-Hour Performance Test in Six Schools.....	55
3	Mean Scores for Program-Taught and Teacher-Taught Sections on the Recall Test in Six Schools.....	58
4	Mean Scores for Program-Taught and Teacher-Taught Sections on the Application Test in Six Schools.....	60
5	Mean Scores for Program-Taught and Teacher-Taught Sections on the Three-Hour Performance Test in Six Schools.....	63
6	Mean Scores for Program-Taught and Teacher-Taught Sections on the Blouse Scores in Six Schools.....	66

CHAPTER I

INTRODUCTION

Problem

A self-instructional program in which the student is guided to perform laboratory tasks and to achieve cognitive objectives concurrently was to be compared with the traditional laboratory-demonstration method of teaching. Specific objectives were (1) to develop a self-instructional program which teaches a skill at the levels of learning which guide the student to an understanding of the processes involved and which prepare the student to transfer learnings to a new task, and (2) to appraise the self-instructional program developed by means of a field experiment in which program and teacher taught sections of classes are compared.

Population for Which Program Was To Be Prepared

The program was to be developed for use with pupils who had had little or no sewing experience. It was to be used primarily with junior and senior high school pupils in their first clothing construction course, regardless of grade level.

Background of the Study

Home Economics Education staff members at the University of North Carolina at Greensboro* became interested in programmed learning in the fall of 1961 when this area of educational technology was in its infancy. A visit was made to the Roanoke, Virginia, public schools to observe pupils who were using self-instructional programs as a part of a field test of the programs. Following this visit, the Home Economics Education staff held a series of seminars to discuss programmed instruction and possibilities for its use in home economics at the secondary level.

*Hereafter this university will be referred to as UNC-G.

Huffman (4) surveyed home economics teachers in North Carolina to ascertain their knowledge of progress which had been made in the field of programmed learning and their readiness to use this method in the classroom. Information about programmed instruction acquired from professional and nonprofessional sources had not adequately prepared home economics teachers to use the programming method. The teachers were interested in programmed instruction and were willing to learn how to use it effectively.

Understanding and use of a sewing machine were chosen as the first areas to be programmed because behavioral objectives could easily be written in these areas and because the researchers believed that the programming of a skill would be a contribution to the fund of knowledge in this new and rapidly developing field. Moore (9) initiated the development of the sewing machine program which was used in the present study. Shoffner (13) revised the sewing machine program on the basis of the recommendations prepared from the preliminary field test conducted by Moore (9).

Theoretical Context of the Problem

Many self-instructional programs are keyed to educational objectives which require only recall levels of learning. For this reason programmed learning may make its best contribution to improved learning if it is used for that portion of learning which must be concerned with facts; thus the teacher is free to prepare more adequately for building on this programmed foundation learning experiences which utilize higher thought processes and the pupil's creativity.

Schramm recommended the above use of programmed learning when he stated:

The real importance of these new machines is that they offer a way to relieve the present over-worked and over-challenged classroom teacher from some of the drudgery of teaching facts and skills By relieving the teacher of such time-consuming, thankless, and often inefficient or impracticable activities, they offer a chance to free time to help individual students, and to help all students acquire the abilities to solve problems, think critically, appreciate art and literature, and develop their creative and inventive talents--kinds of teaching which are not done so well by machines--and thus to raise the quality of education generally (12, p. vii).

The Taxonomy of Educational Objectives: Cognitive Domain

Bloom (1) and a committee of members of the American Psychological Association developed a system of classifying the goals of the educational process which is reported in the Taxonomy of Educational Objectives, Handbook I: Cognitive Domain (1). The major purpose of the Taxonomy was to facilitate communication. In addition to this purpose it served to crystallize in the thinking of many psychologists and educators the idea that there is a hierarchical order of the different classes of objectives. The objectives in one class are likely to make use of and build upon the behaviors found in the preceding classes.

The Taxonomy contained six major classes of cognitive objectives:

1. Knowledge
2. Comprehension
3. Application
4. Analysis
5. Synthesis
6. Evaluation

The more complex behaviors in the Taxonomy include the simpler behaviors. If one takes the Gestalt point of view, it is assumed that the complex behavior is more than the sum of the simpler behaviors. On the contrary, it may be true that the complex behavior is completely analyzable into simpler components. Either way, the educational process can be viewed as one of building complex behavior on the simpler behavior.

Bloom emphasized the importance of knowledge as a foundation for processes of reasoning. He said:

Another justification for the teaching of knowledge is that it is quite frequently regarded as basic to all the other ends or purposes of education. Problem solving or thinking cannot be carried on in a vacuum, but must be based upon knowledge of some of the "realities." The intellectual abilities represented in the taxonomy assume knowledge as a prerequisite (1, p. 33).

Educators agree that the more important educational objectives involve complex behaviors in which application, analysis, synthesis, and evaluation are integral parts. We cannot stop in the learning process with knowledge and comprehension.

Learnings in some classrooms stop with knowledge. Learnings acquired by the use of some self-instructional programs also

stop with knowledge. The plan of the present study included an attempt to write not only a program which would teach a skill, but a program which would also guide the student (1) to an understanding of the function of equipment used, such as parts of the sewing machine, (2) to an understanding of reasons for recommended procedures, (3) to the development of concepts basic to the proper manipulation of patterns or fabric, as well as (4) to the application of certain generalizations which are necessary for the successful completion of a garment without the help of a skilled person, and (5) to an awareness of how the garment would look when procedures were correctly followed. Such a program would teach at the comprehension level of the Taxonomy, and portions of it would teach at the application level.

Transfer of Learning

Learnings which go beyond knowledge to comprehension are more readily applied in situations where they are applicable. Understanding has, therefore, been used as a criterion of transfer in studies of the transfer effect of programmed learning. Keislar said:

Here we have been particularly concerned with the development of "understanding" or "comprehension" as contrasted with "rote" or "superficial" learning. In defining this important objective, it has been useful to follow the point of view expressed early in this line of investigation as follows: "By understanding is meant the ability to answer a variety of questions different from those encountered during training but belonging to the same general class: the broader this class is, the greater is the understanding." This same criterion of transfer has also been expressed by Gagne' in his definition of "knowledge" as "that inferred capability which makes possible the successful performance of a class of tasks that could not be performed before the learning was undertaken" (7, p. 125).

Home economics, particularly the area of clothing construction, seemed particularly suited to investigation of the transfer effects of basic learnings presented in a self-instructional program when the program is written for understanding, concept formation, and formation of generalizations rather than strictly for recall of information.

In home economics there are many facts to be learned. The real evidence of useful learning involves, however, the higher objectives of comprehension and application of principles. The student must be able to construct a garment under the supervision of the teacher as well as to respond correctly to items in a

paper-and-pencil test. She must be able to apply knowledge to a new clothing problem at home in which the commercial pattern is different, the sewing machine is a different brand or model, the fabric is different in weight and texture, and perhaps the garment is for a person with a different body build from hers. These are intricate and difficult problems of transfer of training. The student should also be able to use her knowledge to evaluate ready-to-wear garments from the standpoint of standards of construction and to purchase those for which she receives good value for her money. She faces an additional problem when the garment purchased needs alteration. These are natural, rather than artificial, problems involving transfer of learning.

Clothing construction is a convenient area in which to test the hypotheses because it is possible to develop in this area performance and paper-and-pencil tests which are definitely keyed to those objectives classified as comprehension and application. Such tests can occur in real-life, rather than artificial, situations.

The researchers believed that opportunity to apply learnings during work on an individual project may contribute to transfer of learnings. The project selected for this proposal was the making of a blouse. This project required (1) understanding of commercial patterns and ability to select patterns to fit one's individual figure and (2) understanding of basic construction processes as well as standards for acceptable completion of these construction processes. The making of the blouse is clearly a problem in which principles of use of the sewing machine, principles of interpreting patterns, and principles of construction processes may be applied. Therefore, it is clearly a problem requiring transfer of learnings from the verbal form to the area of performance of a task, in this case a meaningful task.

Relation of Research Design to That of Other Studies in Which Programs Are Appraised

The effectiveness of programs is usually assayed by field testing them under somewhat controlled conditions and measuring what students have learned by the use of one criterion test which is administered as a pre- and a post-test. The effectiveness of programmed learning as a method of teaching is usually tested by comparing achievement, as measured by one criterion test, of classes taught by programmed learning and classes taught by traditional teaching methods.

This study deviates markedly from the above pattern. The project director was concerned that pupils go beyond the recall

level of learning to comprehension, use this knowledge in situations where it may be applied, and make evaluative judgments based on accepted facts--behaviors which are high in the hierarchy of educational objectives. Tests requiring thought processes beyond recall of information and tests of ability to apply learnings in the performance of specified tasks were to be selected or constructed. Five criterion measures were used to assay the effectiveness of the teaching methods.

CHAPTER II

DEVELOPMENT AND APPRAISAL OF THE SELF-INSTRUCTIONAL PROGRAM

The program which was to be written for this study was designed to be the experimental variable. It was of utmost importance that it be effective in the usual sense that a self-instructional program is effective and also that it be innovative. The researchers desired to learn whether or not it was possible to write a program that would teach a skill and would also teach generalizations which would transfer to out-of-class behavior of the student.

Program Developed for the Pilot Study

Prior to the funding of this project a self-instructional program on the sewing machine had been developed by Moore (9) as a problem for a Master's thesis. Four home economists appraised the program at various stages of development and participated in the writing and revision of frames.

Work on the sewing machine program began when the field of programing was in its infancy, 1961-62. Writers of the program had seen a number of programs which were strictly verbal in nature-- programs which taught students to respond only with written words or phrases. It was believed that teaching a student to operate a sewing machine was quite different from the usual problem encountered in programmed learning in that making written responses about a sewing machine would not mean that the student could perform the required tasks. For this reason, performance frames which were to be reinforced by a teacher who observed what the student had just accomplished were included in the program. These performance frames were interspersed among frames requiring verbal responses.

Format

Since subjects using this program were required to perform at the sewing machine, their work space was limited. Reproducing

the program on six-inch by four-inch paper and using rings at the left side made it possible for the program to be placed on the table of the machine in front of the needle.

Illustrations were drawn on many of the frames as an aid to student comprehension of the position of sewing machine parts and of techniques of threading and adjusting the machine.

Student Trial of the Program

Initial frames of the program were read by three students who responded orally as they worked individually with the programmer, making constructive comments or asking questions as they proceeded. This procedure proved most helpful in anticipating problems which needed solution. Comments of students influenced greatly each revision of the frames. Forty students in three schools responded to frames in a group test of the program at this time.

Revision of the Program

One of the early problems encountered during the development of the sewing machine program was the difference among models of sewing machines. At the conclusion of Moore's (9) study, it was evident that frames with illustrations were confusing to students since the illustrations frequently did not coincide with the particular machine at which a student was working. The Home Economics Education staff decided that the operation of each detailed part of the machine could best be understood by preparing illustrations of each of five sewing machine models, a fact which resulted in the preparation of five programs, the major portion of which were identical. Frames common to all programs were printed on white paper, but frames applicable only to certain models of sewing machines were printed on paper of different colors. Thus, there was a program with green inserts to be used with one model of the sewing machine, a program with yellow inserts for another model and three other programs with inserts of additional colors.

This revision of the program incorporating the idea of the parallel forms was completed as a thesis problem by Shoffner, (13). The revised edition included the addition of (1) the separate frames of contrasting color which were inserted to prepare programs for each of five sewing machine models, (2) a hand symbol on some performance frames indicating that the teacher was to check the performance, (3) sections of frames for objectives not programmed in the first edition, (4) an introduction to programmed instruction for the students, and (5) a number of illustrations. The revised program

contained 340 frames of which 71 required no written response and 123 required performance at the sewing machine. Fifteen responses were teacher reinforced. The program was field tested in four schools with 108 students enrolled in first-year home economics classes. Students averaged 12.0 errors on the program, a 3.6 percent error rate. The mean time required to complete the program was 252.2 minutes or approximately five 55-minute class periods.

Training of Programers

At the time the project was funded a sub-contract* was granted to the American Institutes for Research, hereafter referred to as AIR. Personnel from AIR were to conduct a two-week orientation and training course to provide intensive training in basic programing concepts and skills for members of the research team. Members of the AIR staff were also to furnish follow-up, consulting, and editorial services for a one-year period to assist project personnel in the preparation of programed materials.

The two-weeks training course was conducted at UNC-G in September of 1964, with twelve persons participating the first week and six the second week. Half of the sessions during the first week consisted of lectures on learning theory, procedures for preparing program objectives, variations in programing techniques, and procedures for involving students in the empirical development of a program. The remaining sessions were spent in writing various types of programs and executing student try-outs. Members of the research team, participating in the second week of the workshop, concentrated on editing and revising frames on the basis of student response data. A plan of work and a time schedule for the development of the program to be used in the project had been prepared before the training course was completed.

Type of Program Desired

Reference was made in an earlier chapter to the Taxonomy of Educational Objectives, Handbook I: Cognitive Domain (1). An attempt was to be made to develop a program which would guide the student to understand basic principles rather than to memorize a series of accepted facts. The project director was concerned about the comprehension of basic principles, about the use of knowledge

*AIR sub-contract "Assistance and Consulting Services in the Development of Programmed Instructional Materials for Home Economics"

in situations where it may be applied, and about evaluative judgments based on accepted facts--behaviors which are high in the hierarchy of educational objectives. If a program could be written at the application level of the Taxonomy, it was believed that students might be better able to transfer learnings to new situations than students could who are taught in the usual classroom situation.

Most linear programs guide students to memorize basic information in a pleasant learning situation. The student is then able to recall information learned. It is said that the student learns what he responds, and for this reason, a teacher can appraise what students would learn from a given program by reading only the answer frames.

The program to be written for this project was to differ greatly from the above recall type of program in that it would teach at higher levels of the hierarchy in the Taxonomy. There were few innovative programs of this type available and it was understood that new types of frames would have to be developed.

The original plan for the study provided for students to spend three weeks proceeding through a self-instructional program and then to sew for three weeks in a school laboratory situation. The students would perform samples of the sewing tasks while working on the self-instructional program. Early in the development of the program the researchers and consultants realized that it would not be possible in a six-weeks interval to make the necessary samples and also complete a blouse. For this reason, the decision was made to guide students to construct the blouse step-by-step while they were proceeding through the program.

Development of Objectives

Defining objectives is the first step in the development of a self-instructional program. Not only is it necessary to carefully outline and sequence the subject matter, but also it is necessary to specify the intended behavior of the student. As Mager said:

If we are interested in preparing instructional programs which will help us reach our objectives, we must first be sure our objectives are clearly and unequivocally stated. We cannot concern ourselves with the problem of selecting the most efficient route to our destination until we know what our destination is (8, p. 1).

Pilot Study

Before the sewing machine program used in the pilot study was written, the following overall objective was developed: the learner will acquire a knowledge of and skill in the use of one of the following models of Singer sewing machines: 66, 15-91, 301, 201, and 404. One of the subdivisions of this objective specified the names of the parts of the sewing machine which the student was to learn to identify and locate. The student was also to learn to verbalize the purpose of the parts of the sewing machine. The second subdivision of the overall objective consisted of the specification of twelve tasks which the learner was expected to be able to perform upon completion of the program. These objectives were brief and general in nature.

Preparation of Objectives in Behavioral Terms

The plan of work prepared at the conclusion of the AIR workshop had as its first step the preparation of detailed behavioral objectives for each of the three sections of the program--the sewing machine, the pattern, and garment construction. The objectives were to be stated in such a way that they would clearly specify the terminal behavior of the students who successfully completed the program. Objectives were to be prepared in considerable detail to attain such specificity. The situation in which the behavior was to occur and a clear description of the behavior were to be specified. Preparation of objectives in such detail may be expected to facilitate both the writing of frames for the program and the writing of items for an evaluation device which clearly measures attainment of the objectives.

Before behavioral objectives could be written, it was necessary to decide which of the available alternatives for the performing of each task to teach. There is often more than one acceptable way to perform various techniques in garment construction. For example, staystitching may be done on all curved seams or the teacher may specify certain edges that she considers most important to staystitch. It would be necessary in the objective to indicate precisely where staystitching was to be done.

At this time, the need arose for consultation with specialists in the field of clothing. Both quality of sewing and economy of time were to be used as criteria in the selection of the method to use. Two graduate students registered for special problems with a specialist on the Clothing staff at UNC-G. One student was to work in the area of understanding and use of the pattern and the other student in the area of construction techniques. Resource

materials used were clothing text books at the high school level, guide books published by pattern companies, and curriculum guides. A survey was also conducted to learn specific procedures which were commonly used by high school home economics teachers. Several blouses were constructed by one of the graduate students for the purpose of comparing (1) ease of performing a variety of construction techniques, and (2) quality of the finished product when these various techniques were used.

Materials prepared by the graduate students were discussed in seminar sessions in which the clothing specialist, the programers, and a home economics educator participated. In one instance, where there was disagreement about the best procedure to be used by students of this age level, an empirical test was conducted in a junior high school class. At the conclusion of the seminar sessions, the researchers completed the writing of the objectives in behavioral terms (see Appendix A).

Generalizations Included in the Objectives

At the time the proposal for this research project was prepared, the project director envisioned a self-instructional program which differed from the usual linear program in that the learner would be guided to apply generalizations as well as to recall information. In preparation for writing this kind of program, a number of generalizations were written.

Early in the process of writing the first draft of the program, the researchers realized that teaching students to apply generalizations was a much more time-consuming task than they had anticipated. It was of utmost importance that the blouse be completed within a six-week period of time. Since no previous knowledge of sewing was required by members of the target population, the teaching had to cover the broad areas of the sewing machine, the pattern, and construction processes. For this reason, it was necessary to limit the number of generalizations to be taught. All members of the Home Economics Education staff at UNC-G participated in the selection of the generalizations considered to be most important in preparing students to transfer from the classroom task to the sewing of a garment at home (see Appendix A). The generalizations were then incorporated into the objectives.

Appraisal by Consultants

Each section of frames was first reviewed by consultants from AIR who had been assigned to work on the AIR project which had been sub-contracted with UNC-G under the project herein reported.

The consultants responded to frames as though they were students in the target population and then edited frames. Changes in sequencing, subdivision of steps which were too large, and addition of omitted steps as well as changes in wording of frames or changes in responses required were suggested.

At a later stage in the development of the program, the director of the project worked with the researchers in revision of sections of the program in which responses were largely of the recall type or in which the learner was told what to do in a situation in which she could be guided to think and draw conclusions and to thus demonstrate understanding of the material taught.

Student Trial and Revision Cycle

One of the principles of program development is that the program must be empirically developed with members of the target population responding to frames while the program is going through a cycle of student trials and revisions.

Each section of the program was first administered to eighth grade students from the laboratory school at UNC-G, who proceeded through the frames while a member of the research team observed the process. Two students came to the research laboratory after school, on days when they were free to come, for a period of approximately two months. When these students had finished one or two sections of the program, frames in these sections were revised and two additional students began to work on the revised program. This process continued until seven students had completed "The Sewing Machine" and "The Pattern" and six of these same students had completed "Blouse Construction."

The sewing machine section of the program was further tested by administering it to 16 students in two classes at a junior high school in Greensboro. At the conclusion of this group test, slight revisions were made in preparation for the field experiment.

Description of Sewing Step-by-Step

The complete program was entitled Sewing Step-by-Step (5). Series of frames from each section are in Appendix B.

In the sewing machine portion of the program, the student learns the names and functions of the parts of the sewing machine, as well as how to operate it. In addition, she learns to change length of stitches and to evaluate and adjust tension. Basic

principles of how the sewing machine operates have been included so that the student learns to use not only the model she used in the classroom but also other models of machines.

The second part of the program, "The Pattern," deals with understanding and using commercial patterns. This section helps the student select patterns of the correct size and figure type and determine the amount of fabric and sewing notions to purchase. Then the student is guided to prepare the fabric and lay, pin, and cut each pattern piece. The last step in this section is to transfer the necessary markings to the fabric.



While students proceed through the final portion of the program, they actually complete a garment in class. An effort is made to teach construction processes so that the student will be able to go beyond the classroom experience to successful experiences at home using different sewing machines, different patterns, and fabric of different widths. An example of a series of frames from "Blouse Construction" which were specifically designed to teach for transfer can be found in Appendix B, p. 13-21.

This program is different from some in that an active teacher role is built into it. Students are instructed to raise their hands when they complete certain frames so that their answers or the work on their garments can be checked. This procedure gives the teacher an opportunity to check each student's work during the class period as soon as a particular step is completed, and as a result, there is little likelihood that the student will go on without correcting a mistake that may affect later construction processes.

An example of a series of frames from the section on preparation of fabric before pinning pattern pieces is shown in Figure 1. Note that in the first frame the student refers to a panel to answer the question. Several frames later in the same sequence (frame 185), she uses an illustration to apply what has been previously taught. In the last frame shown, she does something to her fabric and before she goes on, the teacher checks it.

Use of Visual and Tactile Aids

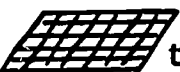
Reference was made earlier to the desire to write a self-instructional program which would teach at higher levels of the Taxonomy of Educational Objectives, Handbook I: Cognitive Domain (1) than at the recall level. The step above recall is comprehension. Attainment of objectives at this second level requires that the student correctly translate information into his own words rather than merely recall the same words used during the learning session.

When fabric is off-grain,  the crosswise threads need to be "squared" to get them on-grain. 

Refer to PANEL 16.

To make this fabric on-grain, it could be "squared" (to fit the card) by pulling on corners

_____ A - C
or
_____ B - D

In which of the diagrams below do the arrows indicate the correct direction to pull the fabric to square it?

_____ 1. _____ 2.

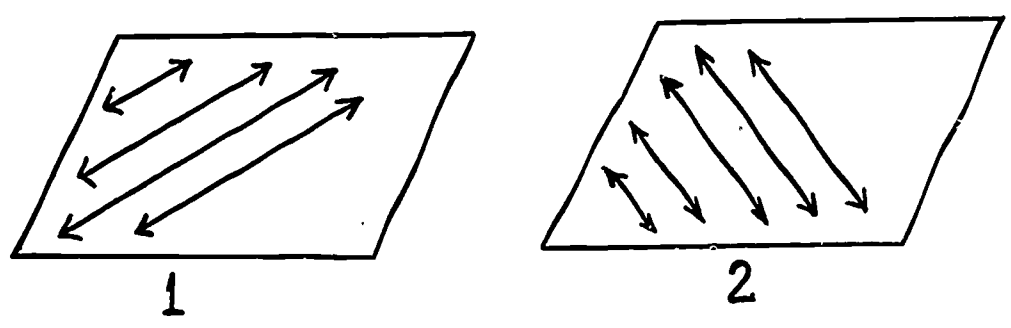

Fold your fabric lengthwise with selvages together.
If it need squaring, find the short corners.



Fig. 1.--Selected frames from Sewing Step-by-Step*

*Reprinted from Sewing Step-by-Step by Johnson, Clawson, and Shoffner by permission of Ginn and Company. Copyrighted 1967.

A program which shapes specific responses would not meet this criteria. Comprehension requires the formation of concepts of new ideas introduced.

A number of panels and exhibits were prepared to guide the student in her understanding of the processes of clothing construction. The use of the senses greatly facilitates concept formation and reduces learning time. Many of the concepts to be acquired in this program involved (1) what happens to fabric when it is manipulated in the process of sewing and (2) standards of appearance of an acceptably completed portion of the sewing task. To acquire concepts of this type, the student must have her attention called to a part of a pattern or pattern guide sheet in isolation, but in full size, with extraneous portions marked out or with the portion to be attended to outlined in color. It is also important that the student have an opportunity to pull or feel fabric samples to acquire certain concepts.

Manilla folders were used for the panels. Contents of the panels were glued to the folder when this was possible, placed in envelopes which had been glued to the folder, or simply inserted in the folder. The panels were numbered and placed in a cardboard box from which the students removed them when directed to do so in the program. Duplicate panels were provided so students would not have to wait to use them. More detailed descriptions of the contents of the panels accompanying each portion of the program are given in the following sections of the report.

Chart and Panel for "The Sewing Machine"

An 8" x 11" labeled chart of a sewing machine, similar to those commonly used by teachers, was developed for each of the sewing machine models programmed. The student was given a chart and as she came to each of the various parts of the sewing machine, she was directed in the program to refer to the chart. After she found the sewing machine part on the chart, she was prepared to find it on the sewing machine to which she had been assigned.

The one panel accompanying the sewing machine section of the program contained samples of fabric stitched with the machine adjusted for satisfactory and unsatisfactory tension. The student used part of the samples while learning to recognize and evaluate tension. The final set of samples was used with criterion frames at the conclusion of the section on tension (see Appendix C).

Panels for "The Pattern"

The thirty-six panels to be used with "The Pattern" contained a variety of types of materials. Included were (1) pieces

of fabric for use in teaching fabric terminology, (2) pattern envelopes, (3) individual pattern pieces, (4) guide sheets, (5) off-grain pieces of fabric, (6) pattern pieces pinned to the fabric, and (7) various combinations of fabric and dressmaker's carbon paper. Brief descriptions of these panels are given in Appendix C.

Panels for "Blouse Construction"

The first series of panels for this section of the program were pieces of fabric cut to resemble necklines of garments for use in the staystitching section of the program. Panels in the second series were used to show the reason for processes such as trimming, clipping, understitching, and bridgestitching. The remaining panels served as evaluation guides or illustrated certain steps in garment construction which are more easily understood when they can be observed in a real-life context (see Appendix C).

Exhibits

The exhibits were collections of larger items which would not fit in a manilla folder, as did the materials in the panels. The exhibits were set up at a convenient place in the classroom and there was only one set of materials for each exhibit. A pressing ham with a dart pinned to it was a part of one exhibit designed to teach students to press curved areas of a garment on a curved surface. Pieces of equipment included in other exhibits were sharp and dull shears, which students used to compare ease of cutting, and dressmaker's carbon paper and tracing wheels which students used to practice marking procedures (see Appendix C).

Group Testing to Determine Error Rate and Time

A self-instructional program is tested on one or more groups of students from the target population so that the program may be appraised from the standpoint of error rate. Students participating in the group test are also given any tests which are to accompany the program. Achievement on such tests is a measure of attainment of objectives of the program.

The group testing, in this case, was a part of the field experiment, students in the program-taught sections being considered the sample of the target population used for the group test. Since the program was developed primarily for the purpose of using it in a research project, more evaluation devices were used than in the usual group test of a program. Achievement as measured by the evaluation devices is reported in Chapter V of this report.

There were classes in six schools participating in the field experiment. Fifty-seven students in these schools were in the program-taught sections. Error rate on frames as well as observations of the researchers concerning frames on which students had problems were recorded. A time record in each section of the program was filled in by the students at the beginning and end of each class period.

Error Rate

The mean error rate for the 57 students in the field experiment for "The Sewing Machine" was 3.90 percent, Table 1. The range of errors made on this section of the program does not appear in Table 1; it was, however, from 0 percent to 15.82 percent. This error rate was based on 158 responses, which included all written responses and performance frames checked by the researchers.

The mean error rate for the same 57 students, based on the 311 responses in the program "The Pattern," was 4.83 percent. Although the range of errors was not reported in the table, it was from 0 percent to 22.19 percent.

Based on 321 responses made by each of the same 57 students, the mean error rate for "Blouse Construction" was 5.97 percent, with a range from .31 percent to 27.41 percent.

The mean error rate for the total program, based on 790 responses, was 5.11 percent with a range from .51 percent to 23.04 percent.

The mean time required for completion of the program was 1,484.99 minutes which would be 24 hours, 44 minutes, Table 2. The time being divided into 55-minute class periods, it took a mean of 27.0 class periods for pupils to proceed through the program.

The mean time required to complete the sewing machine section of the program was 178.46 minutes which would be approximately 2 hours, 58 minutes. The range of time was not reported in Table 2; however, it was 1 hour, 47 minutes to 6 hours, 49 minutes.

The mean time required for students to proceed through the pattern section of the program was 426.22 minutes which would be about 7 hours, 6 minutes, with a range from 4 hours, 40 minutes to 11 hours, 7 minutes.

The mean time needed to complete the construction section of the program was 880.31 minutes or approximately 14 hours, 40 minutes, with a range from 8 hours, 8 minutes to 22 hours, 40 minutes.

TABLE 1

MEAN ERROR RATE FOR SECTIONS AND
SUB-SECTIONS OF THE PROGRAM

Sections and Sub- Sections of Program	Frames		Errors	
	Number	N* x Number of Frames	Number	Percentage (error rate)
"Sewing Machine"				
Sub-Total	158	9,006	351	3.90
"The Pattern"				
Body Measurements	44	2,508	78	3.11
Pattern Envelope	26	1,482	34	2.29
Preparation of Fabric	50	2,850	177	6.21
Pattern Markings	45	2,565	83	3.24
Pattern Layout	79	4,503	275	6.11
Cutting	10	570	17	2.98
Marking	57	3,249	192	5.91
Sub-Total	311	17,727	856	4.83
"Blouse Construction"				
Staystitching and Bridgestitching	64	3,648	194	5.33
Pressing	9	513	15	2.92
Darts	43	2,451	125	5.10
Plain Seams	43	2,451	123	5.02
Facings	25	1,425	62	4.35
Attaching Facings	60	3,420	182	5.31
Sleeves	27	1,539	141	9.16
Hems	9	513	46	8.97
Review	41	2,337	204	8.73
Sub-Total	321	18,297	1,092	5.97
Total	790	45,030	2,301	5.11

*N = 57 students

TABLE 2

TIME RECORD FOR SECTIONS AND SUB-SECTIONS OF THE PROGRAM

Sections and Sub-Sections of the Program	Mean Time for Schools in Minutes						Mean
	1	2	3	4	5	6	
"Sewing Machine" Sub-Total	225.43	171.00	161.41	189.82	161.64	161.50	178.46
"The Pattern" Body Measurements	42.89	36.22	36.41	36.40	31.40	37.85	36.86
Pattern Envelope	18.41	15.80	17.10	16.41	13.61	17.41	16.45
Preparation of Fabric	77.30	67.35	63.32	65.76	77.54	66.80	69.84
Pattern Markings	31.53	27.61	30.65	34.75	27.56	36.24	31.39
Pattern Layout	150.50	138.00	155.00	144.72	98.77	145.26	138.70
Cutting	54.39	39.78	37.63	39.53	30.43	37.48	39.87
Marking	105.41	86.83	97.00	101.14	72.32	96.81	93.25
Sub-Total	480.43	411.59	437.11	438.71	351.63	437.85	426.22
"Blouse Construction" Staystitching and Bridgestitching	166.31	123.54	108.23	119.13	94.45	126.45	123.01
Pressing	8.00	6.51	7.11	7.32	5.32	8.86	7.18
Darts	114.63	97.12	80.10	133.41	71.56	84.10	96.82
Plain Seams	113.54	111.67	92.24	110.45	70.34	93.82	98.67
Facings	75.38	62.00	67.85	63.38	43.85	65.13	62.93
Attaching Facings	192.42	172.91	155.76	164.24	111.31	162.66	159.88
Sleeves	217.54	205.62	166.61	238.87	149.66	214.00	198.71
Hems	115.56	131.74	109.13	134.36	91.72	113.71	116.04
Review	15.00	21.23	19.27	17.41	12.00	17.34	17.04
Sub-Total	1,018.38	932.34	806.30	988.57	650.21	886.07	880.31
Total	1,724.24	1,514.93	1,404.82	1,617.10	1,163.48	1,485.42	1,484.99

The amount of time required seemed to be fairly consistent from school to school with students in School 1 taking the most time and students in School 5 completing the program in the shortest length of time.

Informal Appraisal of Affective Concomitants

The researchers were impressed with the climate of purposeful activity in the classroom with regard to the effective use of time. Students seldom had to wait for help from the teacher and when they did, it was a short wait. A limited number of questions were raised by students, and questions were answered by referring the student to a previous section of the program.

The teacher re-enforcement frames provided an opportunity to check each student's work during the class period as soon as a particular step was completed. Because of this close check student errors were corrected before the next process of garment construction was begun.

CHAPTER III

RATIONALE FOR TYPE OF EVALUATION DEVICES DEVELOPED

Standardized achievement tests, as well as most teacher prepared achievement tests, are norm-referenced tests. Authorities in the field of programmed instruction are currently recommending the use of criterion-referenced in preference to norm-referenced tests. In the section which follows, the two types of tests will be described as a basis for the discussion of types of evaluative instruments developed for the present study.

Norm-Referenced Tests

The development of norm-referenced tests is based on the assumption that there is a continuum of competence of students in any academic area ranging from low to high proficiency. Test scores provide for the ordering of individuals with respect to test performance. The test score indicates, then, the point on the continuum at which behavior of a particular student occurs. Performance of this student is compared with the performance of other students in his group--his score is considered in relation to scores of other students.

Techniques of item analysis commonly used select items to which individuals at varying proficiency levels respond differently and reject items to which all students respond alike. Thus, item selection techniques result in maximizing the variability of the distribution of scores. The distribution of scores on norm-referenced tests approximates a normal distribution with scores clustering around a mean which is near the center of the range of scores.

Criterion-Referenced Tests

Criterion-referenced tests are based on the assumption that all students should attain competence at a specified level. Test scores measure what the student has achieved in relation to

an absolute standard of quality which has been specified. Most students are expected to have reached this standard or to approach it. For this reason, the distribution of scores slopes upward sharply with the highest point at the 100 percent position on the base line. Tests of this variety were once called mastery or minimum-essentials tests.

The standard which students are expected to attain is specified in the behavioral objectives. These behavioral objectives define the acceptable criterion performance. Test scores assess the degree to which the student has attained the criterion performance. Glaser (3, p. 2) clarified the meaning of criterion performance when he said, "The term 'criterion' when used in this way, does not necessarily refer to final end-of-course behavior." Glaser (3, p. 3) indicated that the criterion may rather define one of many points along an achievement continuum which ranges from no proficiency to perfect performance.

The usual item analysis techniques are not appropriate for the development of criterion-referenced tests. Items to which all or most students respond correctly are rejected by the usual item analysis techniques, whereas such items are to be desired in the criterion-referenced test. Items are selected to which the majority of students respond incorrectly prior to instruction and correctly at the end of instruction. Such items maximize the discrimination between groups who have and who have not received instruction and minimize differences among individuals within a group.

The achievement of a group of students who are tested on a criterion-referenced test is expressed as (1) the percent of students attaining a perfect score, (2) the average level of mastery, and (3) the gain in mastery from pre- to post-testing.

Preference of Authorities in Programed Instruction for Criterion-Referenced Tests

The problem of what type of test to develop arose during the early days of programing. Linear programs were to be developed which met the 90/90 criterion--90 percent of the students were to respond correctly to 90 percent of the frames. Behavior was to be shaped so effectively that almost all students attained the level of proficiency specified in terminal behaviors. Obviously, the criterion test must measure the extent to which students did reach this specified level of proficiency if it was to be used as the most important variable in appraisal of the program. Tests, as well as programs, must be 90/90. A new body of psychometric theory

leading to the development of criterion-referenced tests must replace the old theory relevant to the development of norm-referenced tests.

Zaccaria and Olsen expressed their preference for criterion-referenced tests and described the ideal tests as 100/100, rather than 90/90.

In a training situation the ideal is for every student to get zero on each question of the pre-test before training, and for each student to answer every question correctly on the post-test. This would yield a range of 0 and a mean of 100. We should not be teaching students things that they already know and we should attempt to teach all students everything they should know. If this ideal training goal were completely reached, we would not have a normal curve of achievement scores. We would have everyone scoring 100 percent on the final examination (19, p. 213).

Silberman used criterion-referenced measures as early as 1962, presenting as his reason the fact that he was primarily interested in differences between students who had and students who had not taken his experimental program.

Analysis of the criterion test items was concerned largely with the ability of the test to discriminate between students who had been trained with the geometry program and students who had not received the program. It was felt that this form of analysis was more appropriate to the evaluation of programmed instruction than the traditional item analysis techniques based on differences among students who have received the training (14, p. 9).

Glaser expressed in 1963 the concern of programmers for problems of measurement when he stated:

In conclusion, the general point is this. Test development has been dominated by the particular requirements of predictive, correlational aptitude test "theory." Achievement and criterion measurement has attempted frequently to cast itself in this framework. However, many of us are beginning to recognize that the problems of assessing existing levels of competence and achievement and the conditions that produce them require some additional considerations (3, p. 6).

Taber, Glaser, and Schaefer indicated in 1965 that the trend in measurement of achievement resulting from programming should be in the direction of increasing use of criterion-referenced measures.

With increasing application of the concepts of programmed instruction, criterion-referenced scores should become more frequently employed, and the development of measurement procedures for these kinds of scores should be undertaken in a research and development effort (16, p. 172).

Comparison of Norm-Referenced and Criterion-Referenced Tests

A test designed to maximize the discriminations made between groups who have and who have not been taught the assigned material and to minimize differences among individuals within a group would obviously bias any analysis of the effectiveness of a teaching method if one of the methods were used in the process of test development. The test itself exaggerates the difference between the groups and statistically significant differences may occur in a situation in which there is no superiority of one method over the other.

Criterion-referenced tests are appropriate in situations where two groups of students are compared experimentally, both groups having the same program, but differing in such programming variables as the option of by-passing or extrinsic reinforcement. In these cases, the same clearly specified terminal behaviors are the objectives of both groups, and both groups have access to the same programmed material.

When groups taught by a self-instructional program are compared with groups taught by a method other than programming, only norm-referenced tests are appropriate. In this case, it is the students' general understanding of the subject which is to be measured rather than their response to familiar stimuli. The test must not be biased in favor of students taught by either method. As Williams said:

Such tests of the effectiveness of programmed instruction are valid only when the questions are not keyed directly to the programmed material; that is, the items used in the criterion test should be independent of the frames of the program. The test must evaluate the student's general understanding of the material and not his ability to respond to familiar stimuli (18, p. 977).

Rock (10, p. 3) indicated that use of a test on which most of the learners (90 percent) score at the 90th percentile or higher creates a problem which he termed a "ceiling effect." The question is raised of how much more knowledge will have been exhibited if the test does not have a mastery ceiling. Rock said that

Tests of this nature (criterion-referenced tests) would appear to be invalid and impractical for comparative research purposes. Their use would most certainly bias the experimental effort in favor of programmed learning (10, p. 3).

The evaluation devices to be used in the present study were to be based on the specific objectives of the self-instructional program. They were, however, to be of such nature that results would not be biased in favor of either teaching method. The above criteria would best be met by measuring understanding rather than recall of specific terminology used in the program. The language of the evaluation devices must be common to both instructional approaches. Items which measure ability of students to apply learnings to new situations would also be appropriate. The above statement implies that none of the tests could have a mastery ceiling effect, but that they should measure the attainment of that student who had the most proficiency.

Evaluation devices described in the preceding paragraph would be norm-referenced rather than criterion-referenced. Only norm-referenced tests meet the specifications for tests to be used in the present study. For this reason the decision was made that the two paper-and-pencil tests and the two performance tests would be norm-referenced. Items would be written at all levels of the hierarchy through the application level. The usual techniques of item analysis would be appropriate as a basis for selecting and discarding items for each test. Effort would be made to measure the maximum amount of transfer of learnings that might occur in the classroom.

Tests of the above description lend themselves to refined statistical analysis since the distributions of scores are likely to approximate normal distributions. Analysis of variance, analysis of co-variance, multi-variate analysis, the t-test, and a number of other methods of statistical analysis are appropriate only when the distribution of scores is normal.

Norm-Referenced Tests Used in This Study

Five norm-referenced evaluation devices were to be developed for use as criterion variables to measure the outcome of the field experiment. The outcomes of learning which were of interest in this study were varied and complex and for this reason a series of measurements would be needed. It was anticipated that the variables, the scores on the five devices, would be correlated but that each would also measure a specific and unique aspect of pupil achievement.

The researchers believed that only evaluation devices developed to measure learning in this specified situation would be valid to appraise outcomes of the learning process. The objectives for the learner were specific and were stated in behavioral terms. Achievement of these particular objectives could not be measured by any instruments known to the researchers.

Two performance tests, two paper-and-pencil tests and a rating scale for scoring quality of workmanship on the blouse to be made during the field experiment, were to be developed. These tests were described in the research proposal as follows:

1. a one-hour performance test of ability to operate the sewing machine and make adjustments on the machine and of ability to perform some construction processes,
2. a longer performance test of understanding of patterns and of ability to transfer learnings to new situations,
3. a paper-and-pencil test of knowledge of basic facts,
4. a paper-and-pencil test of achievement of objectives higher in the hierarchy of the Taxonomy than knowledge or comprehension,
5. a rating scale to provide a score on quality of workmanship on the blouse.

The evaluation devices are symbolized in this report as follows:

- 1 one-hour performance test
- 3 three-hour performance test
- R recall test
- A application test
- B blouse rating scale

Progress toward each of the objectives for the self-instructional program was to be measured in one of the four tests: 1, 3, R, or A. A logical procedure was to write performance items for objectives for which the terminal behavior was non-verbal and to place these items in the one-hour test if the task was repetitive of a task performed in the classroom and in the three-hour test if the task was an application task.

Items in the latter group were then put into a form suitable for the application paper-and-pencil test if it was not feasible because of limitations of time or if it was not practical to provide for this experience in a performance test. Cases where the

objective specified a verbal terminal behavior, items were written for the recall paper-and-pencil test when it seemed important to measure ability to recall these basic facts.

It was not anticipated that all items would be used but the above procedure insured that the same objective would not be measured in more than one test to the exclusion of measurement of certain other objectives. Each test could then be developed from items in the appropriate classification.

One-hour Performance Test

This test was to be a performance test of the work sample type in which the student was asked to perform as many samples of appropriate tasks as could be completed in one class period (see Appendix D).

Development of Instrument Used in Pilot Study

A preliminary form of this test was developed by Ross (11) to accompany the sewing machine program written as part of the pilot study. The test was developed in four parts and at the end of each part, the student was instructed to stop, raise her hand, and have her work checked before proceeding with the remainder of the test. Subdivisions of the test were as follows:

- I. Bobbin
- II. Threading the Machine
- III. Tension, Stitch-length Regulator, and Stitching
- IV. Zipper Foot

Part I involved filling the bobbin; the procedure tested in Part II was threading the machine; in Part III the student was asked to sew a 5/8-inch seam with ten stitches per inch and correct tension; and the presser foot was removed and the zipper foot inserted in its place in Part IV of the test.

The procedure chosen for scoring the test was a check list, since each step in threading a machine may be considered either right or wrong. The task of preparing the test for scoring involved a detailed listing of points in the process where errors could be made. Instructions to the teacher for administering the test included directions for preparing the machines for the testing program. A list of items to be assembled by the teacher was included with the test materials.

The test was first administered to six students in a Home Economics I class and scored by three home economics teachers. The teachers discussed problems they encountered in administering the test and suggested ways to improve the check list.

Revision of the test followed this first field trial. The test was then administered to Home Economics I students at the UNC-G Laboratory School and in a high school in which the self-instructional program on the sewing machine had been used. Two graduate students and Home Economics Education staff members served as observers.

A second revision of the test was necessary to incorporate the suggestions and comments made by the judges in both situations described above. Items on the scoring sheet were revised to make them more specific. Additional statements about tension adjustment and the bobbin case were considered for a more thorough evaluation of this part of the test. The section on general work procedures was deleted because no students made errors of the type described in this section.

The final form of the performance test was administered to thirty-five students in the high school in which the researcher was teaching, students being scored independently by three judges. Scores of Judge One correlated .95 with scores of Judge Two and .92 with scores of Judge Three, and scores of Judge Two correlated .91 with scores of Judge Three. Scores of Judge One were used to select the upper and lower 27 percent of the group for the purpose of computing the discriminating power of items, using Flanagan's method (17, p. 275).

Further Development and Expansion of Instrument

As a basis for developing a test to be used in this project from the preliminary form of the instrument, the two researchers administered the test to sixteen students and scored the students independently. The resulting correlation between scores of the two researchers was .89. Administration and scoring of the test took fifteen to twenty minutes of student time. The researchers found the test difficult to score since items on the check list were in the form of sentences, each of which had to be read at the time the student's work was checked. Reading was time consuming and it was believed that essential elements could be expressed in phrases. The researchers also found that the sequence could be improved, that it was not possible to see whether or not some steps had been completed correctly, and that all students performed some parts of the task correctly and therefore that these parts need not be included in the check list.

The check list and directions to the student were revised using the above criticisms and adding items to cover program objectives which had been added. Performance test items in the area of "The Pattern" were added, the number of items being limited to the researchers' estimate of what a student could do in one class period. The revised and lengthened test was given an informal trial using eight students.

The test was then submitted to the consultant* on measurement aspects of the project. The consultant was satisfied with the agreement between judges on the sewing machine portion of the test and recommended that the entire test now be administered for the purpose of securing an estimate of reliability. Twenty-six students were tested and the resulting reliability, computed using the Kuder-Richardson Formula 20, was .59. The low reliability was attributed to the small sample of students tested and the fact that the test is relatively short with fifty-five items.

Three-hour Performance Test

The ideal measure of ability to apply learnings to a slightly different task in this case would be to ask the student to make a blouse using a different pattern. This procedure would be far too time consuming for a test situation. It was, however, feasible to isolate a few steps in the construction process which could be performed in a relatively short time. If the student could do these steps correctly, she would likely be able to perform the remaining steps with equal success. For example, if a student sewed one waistline dart correctly, she would be likely to do a shoulder dart or a dart at the bustline with equal success. If she stitched a shoulder seam which met the prescribed standard, the probability is high that other seams on the garment would be satisfactory. Some tasks are crucial in that failure to do them correctly would result in a garment that could not be worn; for example, a garment of printed fabric with the seams on the wrong side could not be worn. An effort was made to measure the student's ability to perform several of these crucial tasks.

Development of the Test

Tasks which met the above criteria were selected and assembled into a preliminary form of a performance test. Directions for the student, directions for preparing materials for using the test, and

*Dorothy Adkins Wood

a check list for use by the observer who scored the test were prepared simultaneously. The preparation of a test of this type necessitated considerable pre-preparation of materials by members of the research staff since some of the cutting, marking, and sewing would be unduly time consuming and repetitious for the student to do as a part of the test.

At the time this test was prepared, the researchers had but a vague idea of the time that might be used by the student in performing the prescribed tasks. The original plan required that one graduate student, majoring in clothing, observe and score two students while they performed the tasks. With this procedure, it had seemed feasible to test only a sub-sample of students in the field experiment. After an early conference with the statistical consultant* for the research project, it was clear that the multivariate analysis to be used required measurement on all criterion variables for all students. Testing a sub-sample on the three-hour performance test would mean that only the sub-sample could be used in any of the analysis. For this reason the decision was made to develop a procedure for scoring the three-hour test which would be feasible for scoring larger groups of students with fewer observers.

There seemed to be an easy solution to the above problem because successful performance of the tasks could be evaluated by scoring the product rather than the performance. The researchers classified all tasks into groups: those for which the product could be scored, and those in which the performance must be scored.

The preliminary form of the test was administered to five students to determine the following:

1. time required to perform the tasks
2. clarity of directions
3. adequacy of materials prepared in advance
4. whether or not one observer could score five students without detaining any of them unduly
5. clarity of directions to the students
6. adequacy of supplies provided for students
7. agreement of judges in scoring the observed items.

All parts of the test were revised and the test was administered to fifteen students in a classroom situation, each student performing one-third of the tasks so that only one class period of student time would be needed. Thus five students performed each third of the test. Further revisions were made and the test was completed for use in the field experiment (see Appendix D).

*Dr. Lyle V. Jones

Description of the Testing Situation

In preparation for administration of the test in each school, sewing units were set up in widely scattered areas in three or four rooms so that the fifteen to twenty students in the class could work simultaneously but completely independently. Upon their arrival, students were given a packet of materials and a few oral instructions. They then proceeded to work at their own pace, raising their hands at points on the instruction sheet where a large black dot had been placed. The observer came to score the performance on the task immediately following the black dot.

Observers kept on a clip board the check sheet for each of the five girls they were watching. A score was recorded for only those items preceded by a star. Other items were scored on the product after it was brought to the university. A sewing machine different from the one used by most of the students in either group was used to test student ability to locate parts and thread a sewing machine different from the one at which she worked in the classroom. Students were asked to come one at a time to this machine to do this part of the test.

Appraisal of the Instrument

Eighty of the ninety-five items, 85 percent, were scored after the product of the performance test was brought to the university. The first 25 such products were scored independently by two researchers as a basis for securing a measure of agreement among judges. Scores assigned by the two researchers for these twenty-five products correlated .99.

Recall Test

Items which had been developed for those objectives which specified a verbal terminal behavior were assembled for a preliminary form of the recall paper-and-pencil test. This test was to be similar to tests which usually accompany self-instructional programs with the exception that it be norm-referenced rather than criterion-referenced.

The preliminary form of the test was submitted to the consultant on measurement aspects of the project and to a Clothing and Textile staff member at UNC-G and subsequently was revised, using their suggestions. Copies were then submitted to one clothing specialist at UNC-G and three clothing specialists at other universities with the request that they answer the test as though they were students and

then suggest any changes which they believed would improve the test. Responses of these specialists were compiled as a basis for developing a scoring key. The specialists disagreed in their responses to a few items. These items were dropped or were reworded on the basis of the specialists' suggestions.

The test was administered to 180 students from the target population in six schools for the purpose of securing an estimate of reliability and data for analyzing items. Point-biserial r was used as the measure of item discriminating power and the percentage of students answering the item correctly was used as the measure of item difficulty. The consultant had recommended dropping only items with negative and very low measures of discrimination. Four of the 101 items were negative and were dropped. Later, a few additional items were dropped because they were repetitious of items in other tests, or because in the process of revising the self-instructional program the objectives had been deleted, or because almost all students answered them correctly.

The Kuder-Richardson Formula 20 was used to compute an estimate of reliability, the resulting coefficient of reliability being .91. The finished test was composed entirely of multiple choice items in which the stem was either a question or an incomplete sentence and in which the student chose an answer from three possible alternatives. Eleven of the eighty-eight items were illustrated (see Appendix D).

Application Test

This paper-and-pencil test was to be a transfer test in that the student was to be asked to apply learnings in a situation slightly different from any situation encountered in the classroom or in the program. Such items would be classified at level three in the hierarchy in the Taxonomy of Educational Objectives, Handbook I: Cognitive Domain (1).

Objectives, the attainment of which it seemed more feasible to measure in a written test than by performance, were assembled for the application of principles test. The test was developed concurrently with the test of recall of information and was submitted to the measurement consultant and specialists in the field of clothing at the same time as the recall test. The application test was submitted to a sample of 192 students in the target population and was subsequently analyzed in the same manner as the recall test. Four of the sixty-four items had negative discrimination indices and were therefore deleted from the test. The test was completed by the students in less than one class period so that items were added to

produce a final test consisting of eighty items. In addition to illustrations in the tests, the student was referred fifteen times to accompanying exhibits. Types of exhibits were samples of tension, pattern guide sheets, fabric to which pattern pieces had been pinned, parts of garments illustrating certain construction processes, and a blouse on which some construction processes had been performed correctly and some incorrectly. These exhibits were used because it was believed that it is more realistic to see the part of the garment under construction about which a decision must be made than it is to see a picture or read a description. Most of the items on this test were of the multiple choice type. The last section consisted of items to which the students responded yes or no or responded by selecting side 1 or side 2 of the blouse exhibit (see Appendix D).

The Kuder-Richardson Formula 20 was used to compute an estimate of reliability. The reliability of this test was estimated to be .75.

Blouse Rating Scale

The fifth criterion variable was a rating scale for scoring quantitatively the quality of workmanship on blouses constructed by students during the field experiment.

Preliminary Form of the Scale

The preliminary form of this rating scale was developed by Solomon (15). The first step was to describe a hypothetical blouse of high quality made by following the self-instructional program. A description of each construction detail of this blouse was formulated and approved by specialists in the area of clothing. A corresponding description of a blouse of inferior quality was also developed.

The decision was made to use a three-level scale. Statements from the description of the top-level blouse formed the basis for the upper level of the three-level scale and statements from the description of the low-level blouse formed the basis for statements at the lowest level. Statements describing a blouse of average quality were added for the middle-level.

Blouses secured from Home Economics I students were used for the initial testing of the rating scale. Scoring of the blouses by each of five judges was recommended by the measurement consultant as the basis for statistical appraisal of the device. Five judges were carefully screened and interviewed before participating in the

project. They then attended a training session before the scoring of the twenty-one blouses was begun.

The rating scale was organized into nine sections and included seventy-six items with a maximum score of 804. On the basis of data secured from the judges during the time they were rating the twenty-one blouses, items were deleted on which (1) the judges disagreed by two or more points, (2) all blouses were scored the same, or (3) an undue amount of time was spent.

The measure of reliability for the rating scale was based on intercorrelations among pairs of judges--each of whom scored twenty-one blouses in a period of one month. These correlations ranged from .65 to .89. Scores of Judge II correlated lower with scores of the other judges than did scores of each of the other judges with each other. The average correlation among judges was .82.

Revised Form of the Scale

The preliminary form of the scale was inadequate for the following reasons: (1) too many subjective judgments were required, (2) phraseology was difficult to interpret, and (3) the rater was required to do too much reading.

The ideal rating scale would be completely objective, would specify quantitatively the quality of construction, and would contain only items on which scores varied. A final score would also be secured in a reasonable amount of time and judges using such a scale would agree on scores for individual items as well as on the total score. It was desired that the closest approximation to such an ideal scale be developed.

In the revision of the rating scale descriptive phrases were re-stated so that the important element was stated succinctly in a minimum of words. The statements were further reduced in length and clarified by substituting the mathematical symbols greater than ($>$), less than ($<$), and equal to (\geq) for the words. Limits of each level of the scale were further defined so that as little subjective judgment as possible was left to the rater.

Description of the Scale

The scale consisted of 121 items divided into nine sections (see Appendix D). Each item was scored 3, 2, or 1, which resulted in a maximum score of 363. Approximately one hour was required for scoring a blouse with the revised scale.

Illustrations and instructions for the judges were assembled in a supplement to the scale entitled "Instructions to the Judges" (see Appendix D). Items on the rating scale for which it was necessary to refer to this supplement were identified with an asterisk.

Five judges scored twenty blouses independently to secure a measure of agreement among judges. Each judge was paired with every other judge and scores of the pairs of judges were correlated-- ten correlation coefficients thus being computed. Coefficients of correlation ranged from .84 to .97. The ten coefficients of correlation were changed to z using Fischer's z transformation of the coefficient of correlation; the z values were averaged and the resulting mean z value transformed back to a coefficient of correlation. The resulting coefficient of correlation, .93, a measure of agreement among judges, was an improvement over the scale developed by Solomon with respect to agreement among judges.

CHAPTER IV

DESIGN AND CONDUCT OF THE FIELD EXPERIMENT

A field experiment was designed to compare by means of a multivariate analysis students taught by the program with students taught by their teachers with respect to five criterion variables. Many studies had been conducted for the purpose of comparing programmed learning with traditional classroom instruction. Programs used were largely of the type which taught students to recall basic information; and differences between program-taught and teacher-taught students were measured by a test developed to accompany the self-instructional program, a test which was a criterion-referenced measure of the mastery type. The present study deviated from the above pattern in that the program represented an effort to teach at higher levels of learning than at the recall level and five criterion measures were used, all of which deviated from the criterion-referenced test commonly used in programmed instruction.

Experimental Design

In each of the schools a class was randomly divided into two sections for a seven-week period. The teacher taught one section and a researcher supervised the other section while students proceeded through the programs. Using the same pattern, all students in both sections made a blouse. Finished blouses were brought to UNC-G for scoring on the rating scale by trained researchers. The four tests were administered to all students. The second performance test, a three-hour transfer test, was given to students in both sections on the first Saturday after completion of the unit.

The design may be considered a randomized complete block design in which schools are the blocks and method of teaching the variable randomized within blocks. This "blocking" by the teacher or class is an important consideration in the design. Bock (2) reasoned that in the simple randomization experiment there is a large component of variation due to schools which appears in the error estimate and reduces the sensitivity of the analysis. A better design would eliminate this component by treating the variable "teacher" as a random block.

Random assignment of students to treatment and control groups is also an important consideration in the design. Since each class was divided into two sections, both experimental and control sections were one-half the usual size of the class. In this respect the size of class differs from the size in the normal school. If size of class has any systematic effect on the criterion variables, it is likely to be to the advantage of the teacher-taught or control sections since more guidance can be given to students who are sewing when the class is small.

The experiment may be diagrammed as follows:

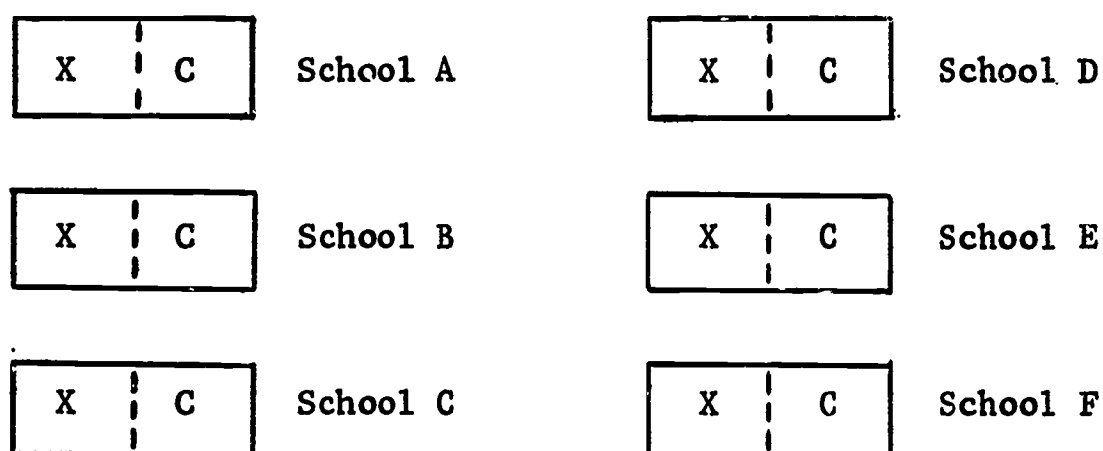

X - experimental or program-taught section
 C - control or teacher-taught section

Method of teaching was the experimental variable of primary interest. The self-instructional program, used in one section of students in each school, is described in Chapter II of this report. Students in the other section in each school were taught by their home economics teacher.

Criterion Variables

Four tests and one rating scale were developed for use as criterion variables in this study. The development of these devices is discussed in Chapter III. They were norm-referenced measures with distributions of scores approximating the normal distribution, and were, therefore, appropriate for use with parametric methods of statistical analysis.

Criterion variables were scores on the following devices:

- 1 one-hour performance test of ability to repeat tasks learned in the classroom

- 3 three-hour performance test of ability to transfer learnings to new situations
- R recall paper-and-pencil test of knowledge of basic facts
- A application paper-and-pencil test of achievement of objectives at the application level
- B blouse rating scale to quantify quality of workmanship.

Sampling Plan

The self-instructional program was developed for junior or senior high school students who had had little or no sewing experience. In the formal school curriculum these students would be enrolled in the first course in home economics--Home Economics I in North Carolina.

The logical sampling unit was a school--in this case, a school with a supervising teacher. Supervising teachers meeting the following specifications were included:

1. teachers with a Home Economics I class of at least 12
2. teachers within 40 miles of Greensboro
3. teachers who would be a supervising teacher in '65-'66
4. teachers who had not worked on the project or helped with previous studies related to the project.

These schools were then matched with schools in which there was not a supervising teacher on the basis of number of teachers on the faculty, size of classes, grade range in the school, and general type and size of community.

Five pairs of schools and an alternate were selected at random from the list of teachers previously mentioned. The county superintendents, principals, and teachers were then contacted. All personnel contacted agreed to participate in the study.

The schools selected were located in three counties and were from seventeen to thirty-five miles from Greensboro. They ranged in size from large county high schools to schools in which grades one through twelve were housed in the same system. Students were from both urban and rural areas.

Assignment of Subjects to Sections

Students within each school were randomly assigned to two sections. One section was selected at random for an experimental section and the remaining section became the control section.

Subjects

Students were given a questionnaire (see Appendix D) to determine their previous experience in the area of clothing construction. The questionnaire consisted of two parts, the first of which pertained to experience with a sewing machine and the second to garments previously made with or without help. The questionnaire was scored to secure a quantitative estimate of previous sewing experience. Previous sewing experience was described as follows: those who

	<u>Score</u>
Had never used a sewing machine and had made no garments	0
Had used a sewing machine but had made no garments	1
Had used a sewing machine and made one garment with help	2
Had used a sewing machine and made one garment without help	3
Had used a sewing machine and made two garments with help	4
Had used a sewing machine and made one garment with help and one garment without help	4
Had used a sewing machine and made two garments without help	5
Had used a sewing machine and made three garments with help	6
Had used a sewing machine and made two garments with and one without help	6
Had used a sewing machine and made one garment with and two without help	6
Had used a sewing machine and made three garments without help	6
Had used a sewing machine and made four garments with help	7
Had used a sewing machine and made three garments with and one without help	7

	<u>Score</u>
Had used a sewing machine and made two garments with and two without help	7
Had used a sewing machine and made one garment with and three without help	7
Had used a sewing machine and made four garments without help	7
Had used a sewing machine and made five or more garments	8

The distribution of students in experimental and control groups among the levels of experience is reported in Table 3.

TABLE 3
NUMBER OF STUDENTS CLASSIFIED AT EACH LEVEL
ON PRE-EXPERIENCE QUESTIONNAIRE

Levels of Experience	Experimental Group	Control Group
0	6	7
1	8	14
2	12	7
3	4	2
4	6	11
5	1	3
6	4	0
7	6	4
8	10	12
Total	57	60

It may be observed that the same number of students (30) in experimental and control groups were at levels 0, 1, 2, or 3. These students had had no experience or had made only one garment. This number is approximately half of the students in the study. If the levels of experience were considered to be scores, the mean score for the experimental group would be 3.8 and the mean score for the control group would be 3.6. There are no apparent differences between the groups in sewing experience prior to the experiment.

The recall paper-and-pencil test, developed as criterion variable R, was administered as a pre-test with items appearing in differing order. The distribution of scores is reported in Table 4.

TABLE 4
FREQUENCY OF DISTRIBUTION OF SCORES ON THE PRE-TEST

Intervals of Pre-Test Scores	Experimental Group	Control Group
16-20	0	2
21-25	2	3
26-30	0	4
31-35	11	3
36-40	7	7
41-45	9	16
46-50	10	11
51-55	9	4
56-60	5	5
61-65	4	4
66-70	0	1
Total	57	60

It may be observed that approximately the same number of students in both groups had low scores (below 35) and high scores (above 56). The mean score for the experimental group was 44.80 and for the control group 43.43. Thus, it can be seen that there was little initial difference between groups as measured by this instrument.

Procedure in Each School

Pre-Planning with the Teacher

A conference with the teacher was held two to three weeks prior to the time the experiment would begin in her school. One of the purposes of the conference was to acquaint the teacher with the procedures and construction processes which were taught in the program and which were to be used by students in both the experimental and control groups. Objectivity of scoring was facilitated by the use of the same procedure by all students. Pattern markings,

for example, may be transferred to the fabric using tailor's tacks, a tracing wheel with dressmaker's carbon paper, or tailor's chalk. All of these procedures may be considered correct, but for this project the use of a tracing wheel and dressmaker's carbon paper was selected. At the time the objectives for the self-instructional program were prepared, project personnel and specialists in clothing at UNC-G had decided what basic information and which of the alternative procedures for completing each construction process to teach in the self-instructional program. The decisions which had been made in the program writing process were developed into specifications for use by the teacher. These specifications were termed "Information for Teachers" (see Appendix F).

A second purpose of this conference was to acquaint the teacher with the list of equipment needed by the students, the blouse pattern which had been selected, restrictions specified by the experiment, and discussion of the details of conducting the experiment in that particular school. Students were required to purchase whatever equipment was ordinarily requested by the teacher; the teacher or the project furnished whatever else might be needed. The teacher was asked to tell the students how much fabric they would need so that their supplies and fabric would be purchased by the first day of the experiment.

The blouse patterns were provided for all students in both sections by Simplicity Pattern Company. All students were to use the same pattern, Simplicity No. 5285 (see Appendix E). This similarity was necessary because each detail of the finished blouse was to be scored, and if some blouses had collars and some had neck facings or if some had sleeves and some were sleeveless, the scores on the blouse rating scale would vary for reasons other than quality of sewing.

It was also important that fabrics of the same type be used by all of the students. The following fabric specifications were given to the teachers:

Choose

cotton or dacron and cotton blends
medium weight
prints or plain colors of medium value
fabrics at least 36" wide
designs on grain, if printed
plain weave

Avoid

sheers, heavy fabrics
white, navy, black, plaids

ribbed or heavy crosswise
yarns

Some of the restrictions discussed with the teacher were as follows:

1. All work on blouses was to be done in the classroom.
2. Demonstrations by the teacher should not involve use of student projects.
3. All work on the blouse was to be done by the student.
4. No deviations from the pattern could be made.

Because the experimental section was to meet in a separate room, provisions for this were also discussed during the conference. A list of the names of the students was obtained so that the researchers could randomly divide the class into two sections.

Instructions to Students

A brief introduction acquainting the pupils with the project was given on the first day of the experiment. During the rest of the class period, the pupils were assigned code numbers, took a pre-test, responded to a sewing experience questionnaire, and were assigned to the control or experimental section.

The second day the researchers met with only the experimental group and gave a brief explanation of programmed instruction. The sewing machine section of the program and the materials accompanying it were distributed to the students. After the students read the section entitled "Directions to the Students," the researchers emphasized certain points which had been made in this section. Specific types of frames such as hand frames, frames requiring use of a panel, and performance frames, were explained. Symbols used in the program were written on the chalkboard and discussed. Students were then instructed to fill out the time record and begin work.

Conditions of Training and Testing

Portable sewing machines had been taken to each school prior to the first day of the experiment, and remained there throughout the duration of the experiment in that school. Each student in both the experimental and control groups had a machine at which to work and used the same machine throughout the unit. This uniformity gave the students equal opportunity to develop skill in the use of one sewing machine model.

During the six weeks of the experiment the students proceeded through the program. The role of the researchers was to check the pupils' work when they reached the reinforcement frames. The researchers had previously decided upon the verbal reply to be made for each reinforcement frame to insure that no help beyond the program would be given to students. The role of the researchers was

to refer students to previous frames, help them take out stitching, or occasionally read frames aloud to slow readers. When students had questions, they were referred to the section of the program which presented the information they needed.

Students in the experimental and control sections within each school were taught during the same class period. If there are differences in achievement among students taught at different times of day, these do not affect group means within schools.

Approximately six weeks of learning and one week of testing was planned for each school. All blouses were to be completed, except for buttonholes and buttons. The exact number of days used for the experiment varied slightly among schools because incidence of illness varied and provision for making up time lost by students was not the same in the schools. Within each school, however, the experimental and control groups had the same number of days to complete the blouse and cover the assigned learning content.

Experimental and control groups in each school were tested together to insure uniformity of test environment. The one-hour performance test was given when students in both sections had completed the sewing machine unit and had their blouse cut out. All other testing was done at the conclusion of the unit when the blouses were completed.

A member of the research team observed five students during the three-hour performance test. Students in experimental and control groups were randomly assigned to groups of five and researchers were randomly assigned to the groups of students. In no case was the student observed by the researcher who supervised her work during the preceding six-week period. Researchers did not know which students in her group had been taught by their teacher and which students had been taught by the program. Each group of five students worked in a separate room unless a large room, such as a library or lunch room, was used, in which case, they worked at opposite ends of the room. Students were spaced in the room so that each would work completely independently.

Time Schedule

Collection of data in each of the schools required approximately a seven-week period of time. Two researchers were available to supervise students in experimental sections so that data were collected in two schools at the same time.

The school year 1965-66 was spent in data collection, the following schedule being followed with a few minor deviations:

Schools 1 and 2.....October 18-December 10
Schools 3 and 4.....January 24-March 11
Schools 5 and 6.....March 16-May 13

Data for the above six schools were analyzed as soon as test data had been scored and transferred to IBM cards. Differences between teacher-taught and program-taught sections of students were so great that the decision was made to collect data of a different type in the remaining schools. This decision was based on the fact that collection of similar data would be unnecessarily redundant.

Data Analysis

A multivariate analysis was used to study simultaneously the extent to which the five criterion variables (the five evaluation devices) differentiated the teacher-taught sections of the classes from the sections taught by the program. In addition, a separate analysis of variance was computed for each of the five separate criterion variables.

Bock (3) wrote a computer program, Manova V, for analyzing multivariate data. This computer program was appropriate for analysis of data collected in this study.

CHAPTER V

ANALYSIS OF DATA AND RESULTS

Plan for Analysis

In each of the six schools which were drawn, one ninth grade home economics class was selected. Students in each class were randomly selected for assignment either to a section receiving programmed instruction or to a section receiving traditional teaching.

Multivariate Analysis of Variance

Method of Analysis

The study designed was basically a multivariate analysis of variance approach with particular emphasis given to the theory and procedure recommended by Jones* (6). The multivariate procedure is a direct extension of the univariate analysis, but enables simultaneous treatment of the five dependent variables.

The alternative procedure would have been to analyze each of the five dependent variables separately, by means of a two-factor analysis of variance similar to that used in a randomized complete block design. In this case "schools" would be comparable to blocks and method of teaching would be the main factor. The multivariate design takes into account the correlation among dependent measures and hence resolves the problems which would have been encountered in interpreting results from five distinct univariate analyses. Jones expresses the preference for multivariate analysis over disjoint univariate analysis as follows:

In comparisons, the multivariate approach pays substantially higher dividends in terms of the rate of convergence of knowledge gleaned from experimentation in psychology (6, p. 31).

*Throughout this section on multivariate analysis, the statistical theory and formulas presented by Jones are used. Recurrent footnotes to this reference are omitted.

This was a two-dimensional analysis, the dimensions being: method of teaching, with two methods and schools, with six schools. The classifications are completely crossed, both methods of teaching being used in each of the six schools.

There are five dependent variables:

1. One-hour performance test (1)
2. Three-hour performance test (3)
3. Recall test (R)
4. Application of principles test (A)
5. Blouse score (B)

The design is, therefore, a five-variate two classification factorial design.

The assumptions for the multivariate analysis are similar to those for univariate analysis of variance. Jones states:

In particular, it is assumed that the within-cell residuals have the multivariate normal distribution with a common covariance matrix, and that observations on different individuals are uncorrelated. The latter condition may be assured by experimental design. Assumptions of normality and homogeneity of covariance, on the other hand, are not so easily secured (6, p. 3).

Hypotheses concerning equal subclass mean vectors were of first importance. The twelve subclass mean vectors as well as two mean vectors for teaching method and six mean vectors for schools are symbolized in Table 5. Each of the twelve vectors consist of

TABLE 5
MEAN VECTORS FOR A TWO-WAY MULTIVARIATE
ANALYSIS OF VARIANCE

Teaching Method	Schools						Mean
	1	2	3	4	5	6	
Program-taught	\bar{X}_{11}	\bar{X}_{12}	\bar{X}_{13}	\bar{X}_{14}	\bar{X}_{15}	\bar{X}_{16}	$\bar{X}_{1..}$
Teacher-taught	\bar{X}_{21}	\bar{X}_{22}	\bar{X}_{23}	\bar{X}_{24}	\bar{X}_{25}	\bar{X}_{26}	$\bar{X}_{2..}$
Mean	$\bar{X}_{.1}$	$\bar{X}_{.2}$	$\bar{X}_{.3}$	$\bar{X}_{.4}$	$\bar{X}_{.5}$	$\bar{X}_{.6}$	$\bar{X}_{..}$

five mean values corresponding to the five dependent variables,
i.e., $\frac{\sum_{px1} X_{11}}{5} = \frac{\sum_{5x1} X_{11}}{5}$.

Three statistical criteria are used to test hypotheses concerning equal subclass mean vectors--Bartlett's χ^2 approximation of the Wilk's criterion, the trace criterion, and the largest root criterion.

Certain features of discriminant function analysis were combined with the multivariate analysis of variance. Since each non-zero root of the equation $\underline{a}q(Mh - \lambda q Me) = 0$, (6, p. 9) has an associated eigenvector \underline{a} , this vector can be used to represent one type of discriminant function; e.g., in the case of a single classification such as methods of teaching, the vector \underline{a} could be used to classify students into the program-taught or teacher-taught sections. The use of the discriminant function in this study is not, however, to classify students but to serve as an aid to better understand the nature of the differences between students taught by the two methods of teaching.

Findings

Students are distributed over schools and sections taught by the program or by their teacher as shown in Table 6. It should be

TABLE 6
CLASSIFICATION OF SUBJECTS

Schools	Methods of Teaching		Total
	Program-Taught	Teacher-Taught	
1	8	9	17
2	10	11	21
3	9	9	18
4	10	11	21
5	10	10	20
6	10	10	20
Total	57	60	117

noted that the subclass numbers are unequal. The computer program, Bock's-Manova V, (2) takes this fact into account and develops the appropriate solution.

The means for students in each section within schools are presented in Table 7. It is clear that for all five variables in each of the six schools the means for the program-taught groups are higher than the means for the teacher-taught groups.

Table 8 reports the multivariate test statistics for five dependent variables testing the hypothesis of no difference in mean

TABLE 8
TESTS OF SIGNIFICANCE

p = 5	Effect		
	Teaching Method	School	Interaction
n_h	1	5	5
n_e	105	105	105
Bartlett's χ^2 for Wilk's criterion			
χ^2	63.97	57.15	43.98
df	5	25	25
prob.	$p < .01$	$p < .01$	$p < .05$

Discriminant function, method of teaching:

$$V_S = +.5964X_1 + .2823X_3 - .0579X_R - .4317X_A + .6180X_B$$

vectors for teaching method, schools, and interaction. The only effect of general interest is teaching method. A significant difference between students taught by the self-instructional program and students taught by their teacher is established by the results reported, i.e., $\chi^2(5) = 63.97$ with $p < .01$. Because of the way schools

TABLE 7
SUBCLASS MEANS

Schools	Tests*	Program-Taught	Teacher-Taught	Means
1	1	46.00	38.56	42.06
	3	93.00	75.33	83.64
	R	73.13	68.44	70.65
	A	55.38	51.78	53.47
	B	300.38	267.33	282.88
2	1	45.20	42.27	43.67
	3	93.50	85.45	89.28
	R	74.60	70.82	72.62
	A	57.80	54.82	56.24
	B	288.50	271.64	279.67
3	1	43.67	35.33	39.50
	3	89.33	75.00	82.17
	R	70.11	64.11	67.11
	A	56.00	51.78	53.90
	B	289.67	233.56	261.62
4	1	46.10	34.82	40.19
	3	94.40	68.91	81.05
	R	76.60	58.45	67.09
	A	58.90	44.45	51.33
	B	301.70	266.91	283.48
5	1	46.40	36.80	41.60
	3	97.60	77.40	87.50
	R	74.50	67.70	71.10
	A	59.70	46.90	53.30
	B	305.90	292.40	299.15
6	1	43.40	36.90	40.15
	3	86.60	69.50	78.05
	R	70.70	67.30	69.00
	A	51.60	52.10	51.85
	B	302.10	266.70	284.40
Means	1	45.12	37.50	41.21
	3	92.43	75.33	83.66
	R	73.49	66.26	69.78
	A	56.61	50.23	53.34
	B	299.51	267.05	282.86

*1: One-hour performance test

3: Three-hour performance test

R: Recall test

A: Application test

B: Blouse score

were selected, it is not surprising that there were significant differences among schools, i.e., $\chi^2(25) = 57.15$ with $p < .01$. A significant interaction is likewise not surprising since there were different teachers in the different schools. Some teachers may be expected to be more effective than others, and this was the case in this study. Differences among schools and the interaction effect will not be further discussed since these were not of general interest in this study. (The discriminant functions for schools and for interactions are not reported since they are not relevant to the purpose of the study.)

It is of interest to explore further the difference between teaching methods to determine the source of the significant difference. This source may best be explained by considering the linear function of the five test scores which maximally discriminates students taught by the program from students taught by their teachers. That function V_S , as reported in the bottom row of Table 7, is $V_S = + .5964X_1 + .2823X_3 - .0579X_R - .4327X_A + .6180X_B$. (Standardized weights appear in the equation.) It may be observed that X_1 , X_B , and X_A account prominently for the differences between teaching methods. These variables are the one-hour performance test, the blouse rating scale, and the application of principles test. Variables X_1 and X_B discriminate in a positive direction whereas the weight for X_A is negative. Sign and size of weights are not necessarily related to size of mean difference between groups when five variables are available for prediction. The weights are determined by complex statistical relationships among the variables. While it is true that the application test (A) has a negative weight in the discriminant function, this does not imply that the test is of negative value in prediction nor that on that test the teacher-taught sections performed better than the program-taught sections. The correct interpretation includes the thought that maximum discrimination between means of the program-taught and teacher-taught groups is attained by including the application test with a negative weight. Prediction is improved by the use of the negative variable.

It is clear that when the five dependent variables are considered together, there are large differences between the teacher-taught and program-taught sections. These differences could not be due to chance factors and must be attributed to the superiority of the program as contrasted with methods used by the teacher.

Inter-correlations Between Dependent Variables

Product-moment error correlations were computed for each combination of two variables. These are correlations of scores after partialling out those effects associated with teaching method

and schools. The resulting error correlation matrix is recorded in Table 9. The two paper-and-pencil tests (tests R and A) are

TABLE 9

PRODUCT-MOMENT ERROR CORRELATIONS FOR
FIVE DEPENDENT VARIABLES

	<u>1</u>	<u>3</u>	<u>R</u>	<u>A</u>	<u>B</u>
1 One-hour performance test		.69	.59	.60	.50
3 Three-hour performance test			.73	.72	.54
R Recall test				.80	.47
A Application test					.48
B Blouse rating scale					

more closely correlated than any of the other tests, the γ value being .80. The lowest correlations were between the blouse scores and written tests, .47 and .48. Inter-correlations among the four test scores (ranging from .59 to .80) were higher than any of the correlations between the tests and blouse score (ranging from .47 to .54).

Analysis of Each Dependent Variable

Since the outcome of the multivariate tests for each hypothesis tested, i.e., methods, schools, and interaction, were significant, this outcome implies that one or more of the dependent variables are discriminating the hypothesis in question. Each was then analyzed separately using the two factor analysis of variance design to determine which of the variables discriminated methods of teaching, schools, and interaction.

Analysis of Scores on the One-Hour Performance Test

Differences between the program-taught and teacher-taught sections on the one-hour performance test were significant beyond the 1 percent level, Table 10.

Differences among the six schools on the one-hour performance test were not significant and there was no significant interaction between method of teaching and schools.

TABLE 10

ANALYSIS OF VARIANCE OF SCORES
ON ONE-HOUR PERFORMANCE TEST

Source of Variation	Degrees of Freedom	Mean Square	F
A. Schools	5	47.79	1.65
B. Method of Teaching	1	1,717.04	59.39**
Interaction between A and B	5	42.76	1.48
Error	105	28.91	
Total	116		

**p < .01

Differences among the six schools on the one-hour performance test were not significant and there was no significant interaction between method of teaching and schools.

The average mean of the program-taught section was 45.12 and the average mean of the teacher-taught section was 37.50, the difference between the two being 7.67. Since the means for the program-taught and teacher-taught sections were significantly different, it was of interest to report these means within schools. In Table 11 it may be seen that the program-taught section is superior to the teacher-taught section in each of the six schools.

TABLE 11

MEAN SCORES FOR PROGRAM-TAUGHT AND TEACHER-TAUGHT SECTIONS
ON ONE-HOUR PERFORMANCE TEST

Schools	Program-Taught Section	Teacher-Taught Section
1	46.00	38.56
2	45.20	42.27
3	43.67	35.33
4	46.10	34.82
5	46.40	36.80
6	43.40	36.90
Average Mean	45.12	37.50

Performance test scores for program-taught sections are similar from school to school, as may be observed in Figure 2.

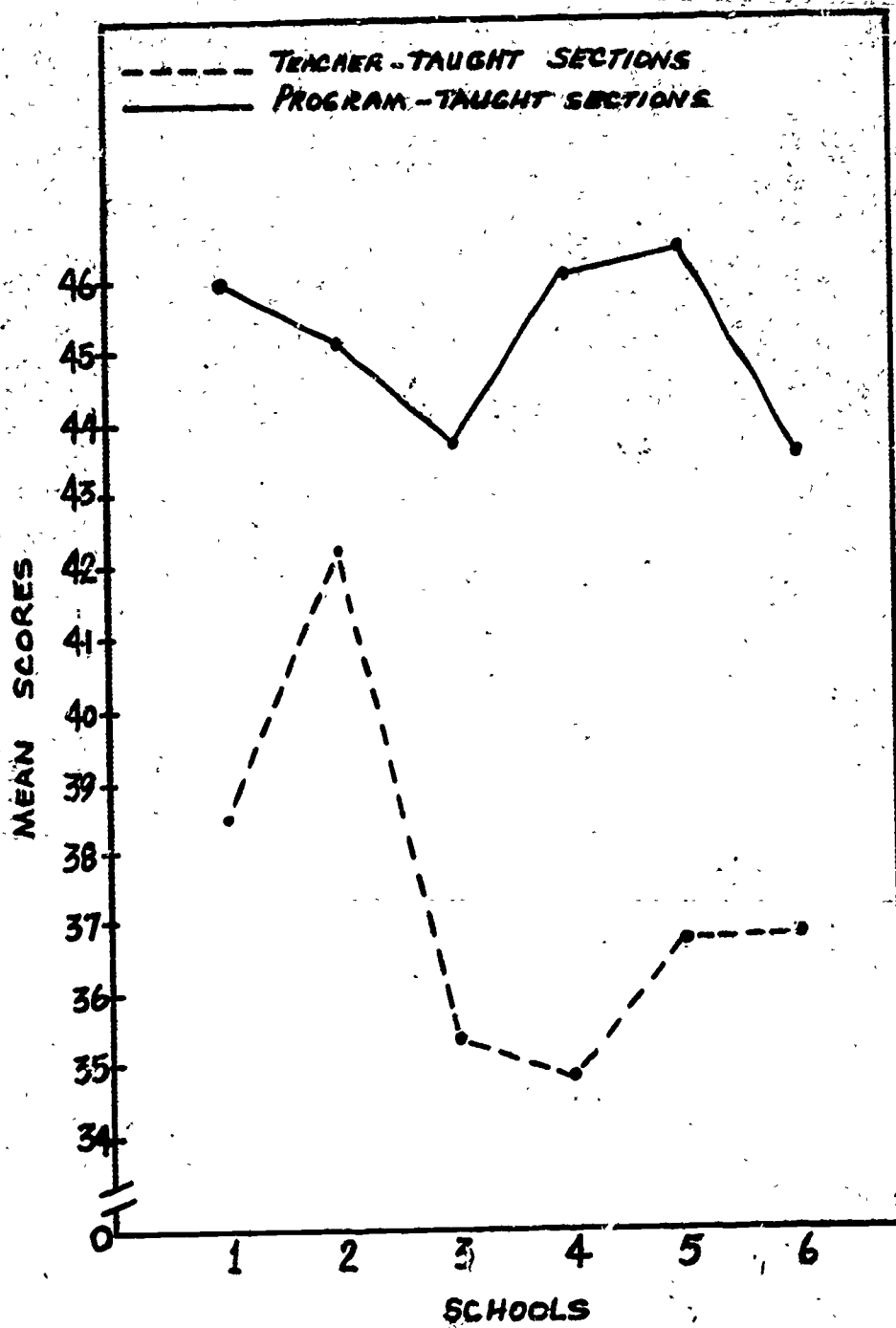

Fig. 2.--Mean scores for program-taught and teacher-taught sections on the one-hour performance test in six schools.

Scores for teacher-taught sections, on the other hand, vary from school to school. These differences are not, however, great enough to result in a significant F-ratio for interaction between method of teaching and schools.

Differences between program-taught and teacher-taught sections within each school were analyzed using the t-test. Results are reported in Table 12. These differences were significant

TABLE 12

t-TEST FOR DIFFERENCE BETWEEN EXPERIMENTAL AND CONTROL GROUPS
WITHIN SCHOOLS FOR ONE-HOUR PERFORMANCE TEST

Schools	Mean Difference	Standard Error	t
1	7.44	3.05	2.43*
2	2.93	2.31	1.27
3	8.33	2.43	3.43**
4	11.28	2.16	5.22**
5	9.60	2.32	4.14**
6	6.50	2.44	2.66**

*p < .05
**p < .01

beyond the 1 percent level in four of the six schools and 5 percent level in one school; the difference was not significant in one school.

Analysis of Scores on the Recall Test

In Table 13 it can be seen that differences between the program-taught and teacher-taught sections on the recall test were significant beyond the 1 percent level. Differences among the six schools on the recall test were not significant and there was no significant interaction between method of teaching and schools.

The means for the program-taught section were higher than those for the teacher-taught section in each of the six schools, Table 14. The average mean of the program-taught section was 73.49 and of the teacher-taught section, 66.26. The average mean difference was 7.28.

Recall test scores for program-taught sections are similar from school to school, as shown in Figure 3. On the other hand, scores for teacher-taught sections vary from school to school. These differences are not, however, great enough to result in a significant F-ratio for interaction between method of teaching and schools.

TABLE 13

ANALYSIS OF VARIANCE OF SCORES ON RECALL TEST

Source of Variation	Degrees of Freedom	Mean Square	F
A. Schools	5	101.09	1.17
B. Experimental-Control	1	1,548.47	18.00**
Interaction between A and B	5	158.98	1.85
Error	<u>105</u>	86.01	
Total	<u>116</u>		

**p < .01

TABLE 14

MEAN SCORES FOR PROGRAM-TAUGHT AND TEACHER-TAUGHT SECTIONS ON THE RECALL TEST

Schools	Program-Taught Section	Teacher-Taught Section
1	73.13	68.44
2	74.60	70.82
3	70.11	64.11
4	76.60	58.45
5	74.50	67.70
6	<u>70.70</u>	<u>67.30</u>
Average Mean	73.49	66.26

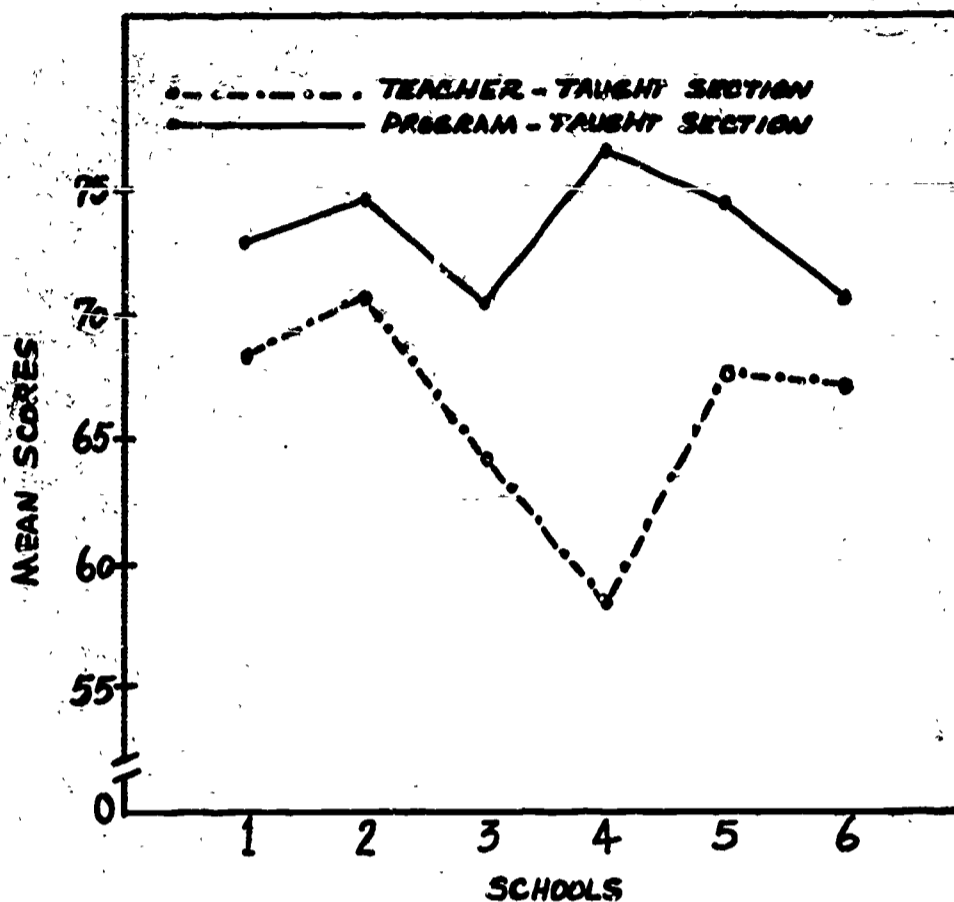

Fig. 3.--Mean scores for program-taught and teacher-taught sections on the recall test in six schools.

The t-test was used to analyze the differences between program-taught and teacher-taught sections within each school. In Table 15,

TABLE 15

t-TEST FOR DIFFERENCE BETWEEN EXPERIMENTAL AND CONTROL GROUPS WITHIN SCHOOLS FOR RECALL TEST

Schools	Mean Differences	Standard Error	t
1	4.68	3.87	1.21
2	3.78	3.27	1.16
3	6.00	4.59	1.31
4	18.14	4.21	4.31**
5	6.80	4.69	1.45
6	3.40	4.41	.77

**p < .01

it may be observed that these differences were significant beyond the 1 percent level in one of the six schools and were not significant in the other five schools.

Analysis of Scores on the Application Test

Differences between the program-taught and teacher-taught sections on the application test were significant beyond the 1 percent level, Table 16. Differences among the six schools on the application

TABLE 16.

ANALYSIS OF VARIANCE OF SCORES ON APPLICATION TEST

Source of Variation	Degrees of Freedom	Mean Square	F
A. Schools	5	62.22	.67
B. Method of Teaching	1	1,197.37	12.84**
Interaction between A and B	5	179.54	1.92
Error	105	93.26	
Total	116		

**p < .01

test were not significant and there was no significant interaction between method of teaching and schools.

Because the observed means for the program- and teacher-taught sections were significantly different, it is appropriate to report the means within schools. The average mean of the program-taught section was 56.61 and the average mean of the teacher-taught section was 50.23, the difference between the two being 6.40. In Table 17 it may be seen that the program-taught section is superior to the teacher-taught section in five of the six schools, and that in the sixth school, the mean score of the teacher-taught section exceeded that of the program-taught section by a standard score (\bar{z}) of 0.04.

It can be seen in Figure 4 that there is more variation in the application test scores for the teacher-taught group than for the program-taught group. However, these differences were not great enough to result in a significant F-ratio for interaction between method of teaching and schools.

TABLE 17

MEAN SCORES FOR PROGRAM-TAUGHT AND TEACHER-TAUGHT SECTIONS
ON THE APPLICATION TEST

Schools	Program-Taught Section	Teacher-Taught Section
1	55.38	51.78
2	57.80	54.82
3	56.00	51.78
4	58.90	44.45
5	59.70	46.90
6	51.60	52.10
Average Mean	56.61	50.23

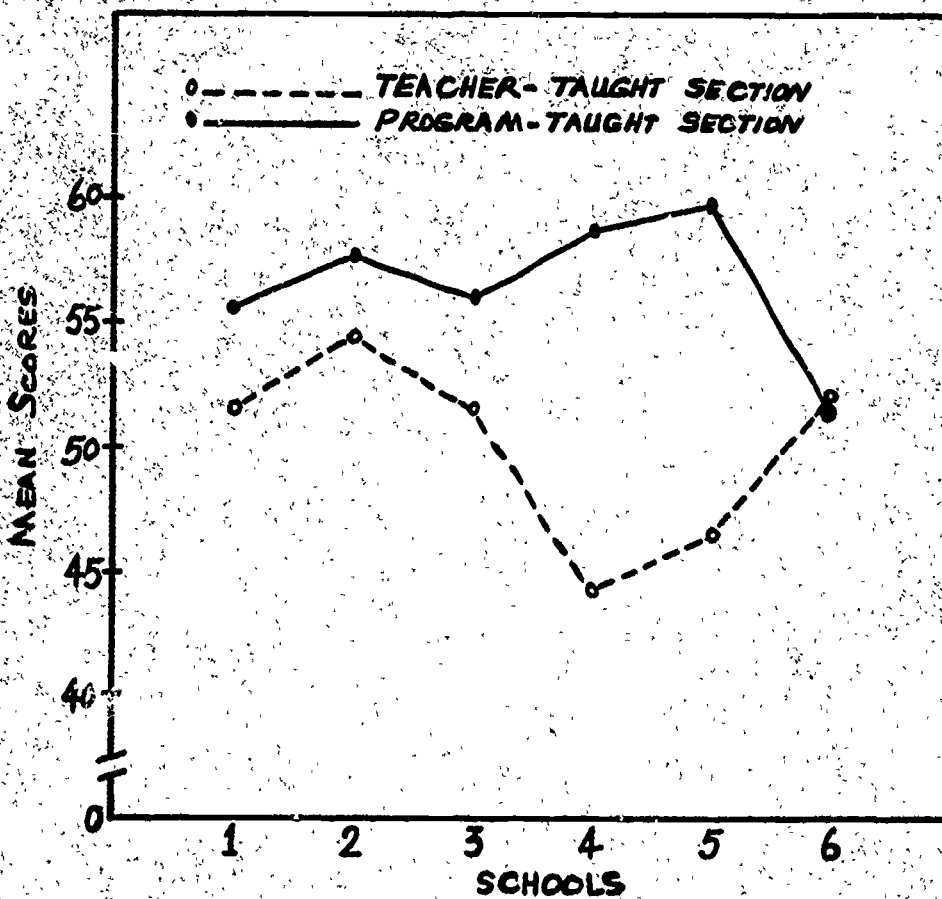

Fig. 4.--Mean scores for program-taught and teacher-taught sections on the application test in six schools.

Differences between program-taught and teacher-taught sections within each school were analyzed using the t-test. In Table 18

TABLE 18

t-TEST FOR DIFFERENCE BETWEEN EXPERIMENTAL AND CONTROL GROUPS
WITHIN SCHOOLS FOR APPLICATION TEST

Schools	Mean Difference	Standard Error	t
1	3.60	5.38	.67
2	2.98	3.50	.85
3	4.22	4.92	.85
4	14.44	3.77	3.83**
5	12.80	4.89	2.61**
6	.50	3.97	.13

**p < .01

it may be observed that the differences were significant beyond the 1 percent level in two schools and in four schools the differences were not significant.

Analysis of Scores on the Three-Hour Performance Test

On the three-hour performance test differences between the program-taught and teacher-taught sections were significant beyond the 1 percent level, Table 19. There was no significant difference among the six schools on the three-hour performance test and no significant interaction between method of teaching and schools.

The average mean of the program-taught section was 92.43 and of the teacher-taught section 75.33, the difference between the two being 17.17. Since the means for the program-taught and teacher-taught sections were significantly different, it was of interest to report the means within schools. In Table 20, it may be seen that the program-taught section is superior to the teacher-taught section in each of the six schools.

Figure 5 indicates that although there is some variation in three-hour performance test scores for the program-taught group

TABLE 19

ANALYSIS OF VARIANCE OF SCORES ON
THREE-HOUR PERFORMANCE TEST

Source of Variation	Degrees of Freedom	Mean Square	F
A. Schools	5	354.48	1.69
B. Method of Teaching	1	8,609.37	41.09**
Interaction between A and B	5	176.38	.84
Error	105	209.51	
Total	116		

**p < .01

TABLE 20

MEAN SCORES FOR PROGRAM-TAUGHT AND TEACHER-TAUGHT SECTIONS
ON THREE-HOUR PERFORMANCE TEST

Schools	Program-Taught Section	Teacher-Taught Section
1	93.00	75.33
2	93.50	85.45
3	89.33	75.00
4	94.40	68.91
5	97.60	77.40
6	86.60	69.50
Average Mean	92.43	75.33

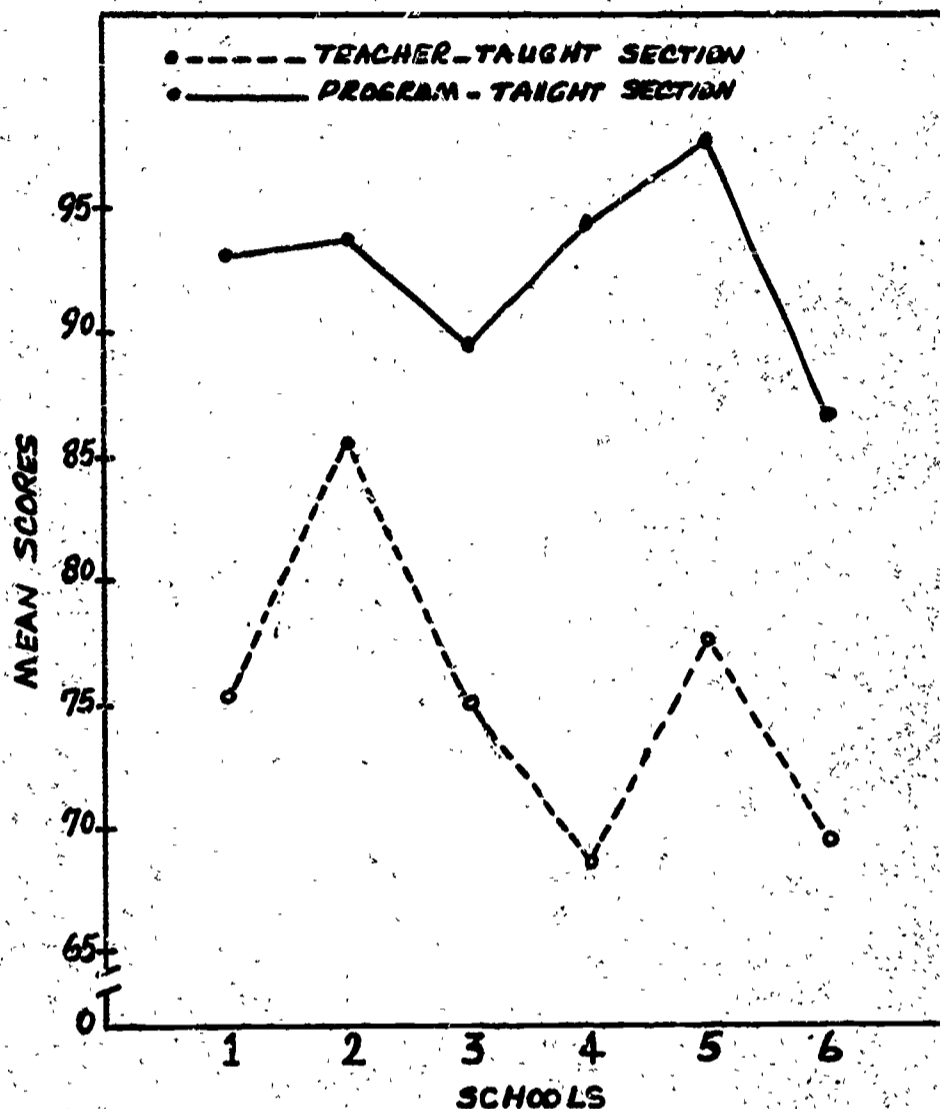

Fig. 5.--Mean scores for program-taught and teacher-taught sections on the three-hour performance test in six schools.

from school to school, there is more variation among scores for the teacher-taught groups. These differences are not, however, great enough to result in a significant F-ratio for interaction between method of teaching and schools.

The t-test was used to analyze differences between the program-taught and teacher-taught sections within each school. Results reported in Table 21 indicate that the differences were significant beyond the 1 percent level in two schools, beyond the 5 percent level in three schools, and not significant in one school.

TABLE 21

t-TEST FOR DIFFERENCE BETWEEN EXPERIMENTAL AND CONTROL GROUPS
WITHIN SCHOOLS FOR THREE-HOUR PERFORMANCE TEST

Schools	Mean Difference	Standard Error	t
1	17.67	7.98	2.21*
2	8.04	5.51	1.46
3	14.33	7.66	1.87*
4	25.49	5.45	4.67**
5	20.20	5.94	3.40**
6	17.10	7.13	2.39*

*p < .05

**p < .01

Analysis of Scores on Blouse

This was a non-orthogonal design. For this reason the significant interaction must be considered first, Table 22. Note

TABLE 22

ANALYSIS OF VARIANCE OF SCORES ON BLOUSES

Source of Variation	Degrees of Freedom	Mean Square	F
A. Schools	5	2,729.99	6.16**
B. Method of Teaching	1	28,193.69	63.62**
Interaction between A and B	5	1,121.02	2.53*
Error	<u>105</u>	443.19	
Total	116		

*p < .05

**p < .01

that the magnitude of the interaction effect is small compared to the F-ratio for method of teaching which is highly significant. In spite

of significant interaction, there is no doubt that the score on the blouse rating scale is discriminating between method of teaching, Table 22. Differences among the six schools on the blouse scores were significant beyond the 1 percent level and the interaction between method of teaching and schools was significant beyond the 5 percent level.

In Table 23 it can be observed that the average mean blouse score for the program-taught group was 299.51, and for the

TABLE 23
MEAN SCORES FOR PROGRAM-TAUGHT AND TEACHER-TAUGHT
SECTIONS ON BLOUSE

Schools	Program-Taught Section	Teacher-Taught Section
1	300.38	267.33
2	288.50	271.64
3	289.67	233.56
4	301.70	266.91
5	305.90	292.40
6	302.10	266.70
Average Mean	299.51	267.05

teacher-taught section 267.05, with a difference between the two of 31.07. The program-taught section is superior to the teacher-taught section in each of the six schools.

Blouse scores for program-taught sections are similar as it may be observed in Figure 6. Scores for teacher-taught sections, on the other hand, show a marked variation from school to school. These differences were great enough to result in a significant F-ratio for interaction between method of teaching and schools.

Differences between program-taught and teacher-taught sections within each school were analyzed using the t-test. Results are reported in Table 24. These differences were significant beyond the 1 percent level in four of the six schools and beyond the 5 percent level in one school, and were not significant in one school.

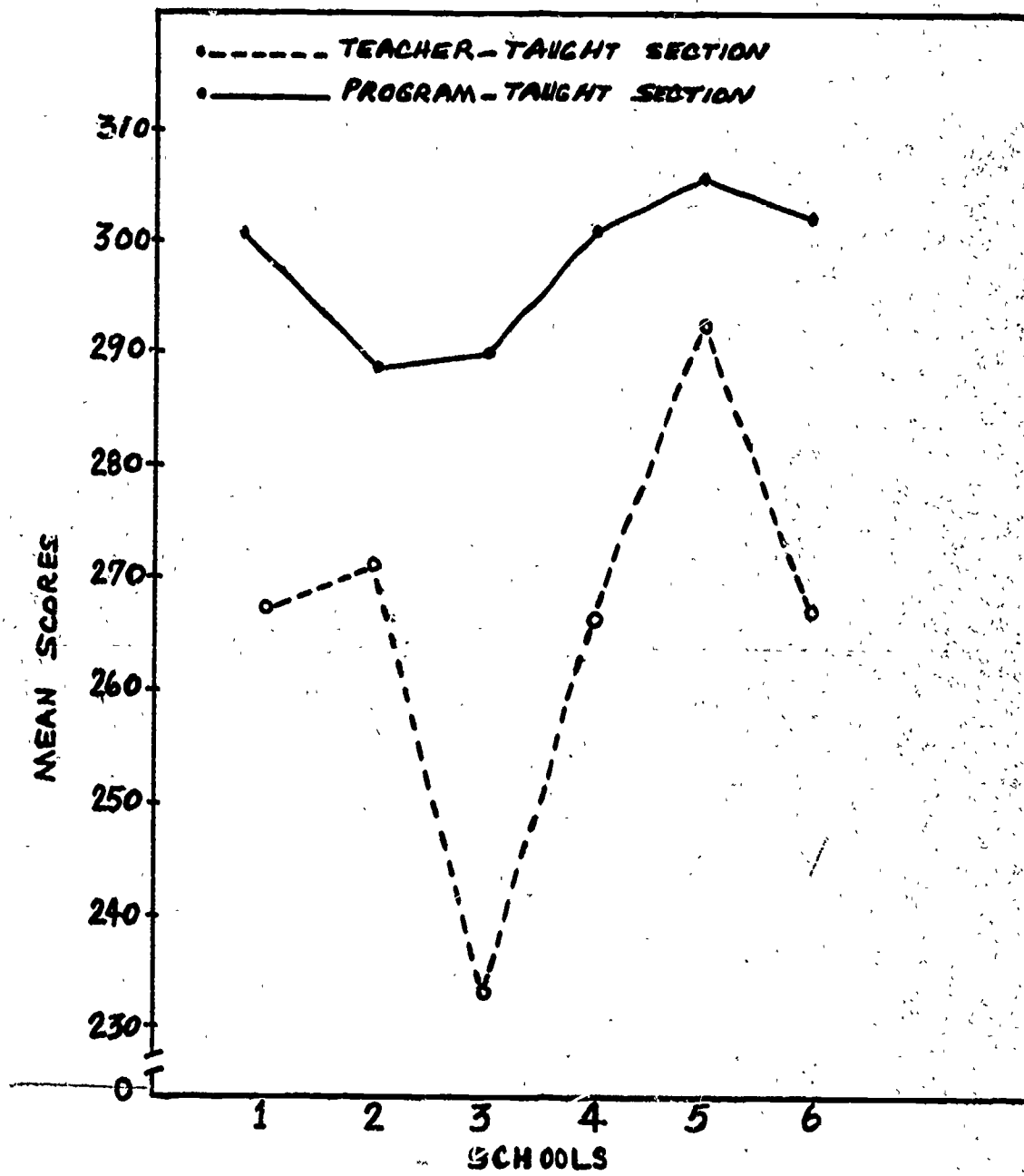

Fig. 6.--Mean scores for program-taught and teacher-taught sections on blouse scores in six schools.

TABLE 24

t-TEST FOR DIFFERENCE BETWEEN EXPERIMENTAL AND CONTROL GROUPS
WITHIN SCHOOLS FOR BLOUSE

Schools	Mean Difference	Standard Error	t
1	33.04	7.21	4.58**
2	16.86	14.52	1.16
3	56.11	8.77	6.39**
4	34.79	8.72	3.99**
5	13.50	6.61	2.04*
6	35.40	7.60	4.65**

*p < .05

**p < .01

Summary and Conclusions

All five dependent variables significantly discriminated the program-taught from the teacher-taught sections, the program-taught sections being superior in each case.

The variables which most successfully discriminated between program-taught and teacher-taught sections were the blouse rating scale, the one-hour performance test, and application test. The blouse score, obtained from the rating scale, was the most sensitive measure of what was learned.

From the separate analyses of the five variables as well as from the multivariate analysis and discriminant function, it was apparent that blouse scores discriminated program-taught from teacher-taught sections. Furthermore, blouse scores discriminated schools and indicated a school by method interaction.

The same variables had large F-values and large Beta-weights. This indicated that there is consistency in the data and in methods of analysis. Variables that were strong in one kind of analysis continued to be strong in other kinds of analyses.

The conclusion may be drawn that programmed teaching led to improved garment construction. Not only did program-taught students construct garments of quality superior to that of teacher-taught

students but this learning also transferred to situations in which students responded to written and performance tests. The making of the blouse generalized to other tasks.

Performance of program-taught students on all five variables was consistent from school to school whereas performance of teacher-taught sections varied considerably from school to school. Relatively consistent and superior results may be expected from use of the program.

CHAPTER VI

REVISION OF PROGRAM AND TRIAL IN CLASS OF NORMAL SIZE

The null hypotheses stated as a part of this study were clearly rejected on the basis of data analyzed at the conclusion of the experiment in six schools. Collection of identical data in additional schools would be redundant and an unnecessary expenditure of time and money, according to Jones, the statistical consultant.

The researchers realized that the self-instructional program used in the study would require revision before it was made available for general classroom use. Separate programs had been prepared for each of six models of sewing machines. Teachers who might be using models other than these six might also find it inconvenient to keep the right program associated with each machine in the classroom. If one general section on sewing machines which worked for all models of machines could be written, this would greatly facilitate use of the program in the classroom.

One specific blouse pattern was used throughout the pattern and construction sections of the program. This pattern would become obsolete making the pattern program obsolete. Also, home economics teachers frequently use some garment other than a blouse as the first project to be constructed by students. If the program could be written in such a way that within limitations students were permitted to use patterns of their own choice, the program would be more appropriate for general classroom use.

For these reasons, the decision was made to revise the program as a part of this research project. Revisions were made not only to make the program more general in nature, but also to improve sections where error rates had been the highest and to improve sections related to test items most frequently missed.

The Revised Program

The sewing machine section of the program can now be used with any model or make of sewing machine. Illustrations and frames

keyed to any specific model were rephrased or supplementary illustrations were added showing that part on a variety of sewing machine models. The student was guided to transfer information to the machine at which she was working. Labels to be taped to parts of the sewing machine were substituted for the series of charts of sewing machines, one for each of six models. Such problems as whether the hand wheel revolves clockwise or counterclockwise were solved by having the teacher label the hand wheel with an arrow which indicated the correct direction.

References to a specific blouse pattern were removed from both the pattern and construction sections of the program. Descriptive phrases and illustrations were revised to make them more general. A few panels which were difficult to reproduce were omitted from the program. A few inductive or discovery sequences were substituted for sequences which shaped recall rather than understanding types of behavior.

Group Test of the Revised Program

The revised program was used in classes in two schools with a total of 35 students. These classes were not divided in half as had been done with classes in the earlier field experiment, since the purpose this time was to determine the effectiveness of the program in a normal classroom situation.

Students were pre-tested using the same test that was used in the earlier study. The mean score for this group was 44.75 as compared to 44.80 for the experimental group and 43.43 for the control group in the earlier field experiment. Thus, the groups were similar in relation to background information they held previous to taking the program.

The students were also asked to respond to the sewing experience questionnaire. Their mean score for experience was 2.9 which was lower than either the experimental group (3.8) or the control group (3.6) in the earlier study. Sixty percent of the students using the revised program had had no previous sewing experience or had made only one garment. In the earlier study, only fifty percent of the students were categorized in the above categories.

The average time required for the completion of the revised program was 28 hours, 15 minutes as compared to 24 hours, 45 minutes for the original program. The difference was probably due to the larger class size and the fact that students would occasionally have a short wait before their work could be checked.

The mean error rate for the 35 students using the revised sewing machine program was 4.37 percent, Table 25. Although the

TABLE 25
MEAN ERROR RATE FOR SECTIONS AND SUB-SECTIONS
OF THE REVISED PROGRAM

Sections and Sub-Sections of Program	Frames		Errors	
	Number	N* x Number of Frames	Number	Percentage (error rate)
"Sewing Machine"				
Sub-Total	155	5,425	237	4.37
"The Pattern"				
Body Measurements	44	1,540	32	2.07
Pattern Envelope	28	980	23	2.35
Preparation of Fabric	59	2,065	98	4.75
Pattern Markings	44	1,540	33	2.14
Pattern Layout	88	3,080	94	3.05
Cutting	10	350	11	3.14
Marking	57	1,995	95	4.76
Sub-Total	330	11,550	386	3.34
"Blouse Construction"				
Staystitching and Bridgestitching	56	1,960	78	3.98
Darts	42	1,470	69	4.69
Plain Seams	45	1,575	63	4.00
Facings	27	945	33	3.49
Attaching Facings	59	2,065	44	2.13
Sleeves	28	980	59	6.02
Hems	16	560	36	6.43
Review	41	1,435	88	6.13
Sub-Total	314	10,990	470	4.28
Total	799	27,965	1,093	3.97

*N = 35 students

range is not reported in the table, it was from 0 percent to 14.8 percent. This error rate was based on 155 responses which included all written responses and performance frames checked by the researcher.

The mean error rate based on 330 responses for "Understanding and Using Patterns" was 3.34 percent with a range from 0 to 11.2 percent.

Based on 314 responses, the mean error rate for "Construction Techniques" was 4.28 percent with a range of .6 to 12.7 percent.

The mean error rate for the total revised program, based on 799 responses, was 3.97 percent as compared to 5.11 percent on the original program. The range of error rates was .9 to 11.6 percent.

The four tests were administered following the same procedures that were used in the other six schools. Blouses were again scored at UNC-G. Mean scores on three of the evaluation devices--the one-hour performance test, the written application of principles test, and the rating scale--were almost the same as mean scores of students in the experimental section of the field experiment (the program-taught section), Table 26. Mean scores

TABLE 26

COMPARISON OF MEAN SCORES ON THE FIVE EVALUATION DEVICES
OF STUDENTS USING THE ORIGINAL
AND REVISED PROGRAMS

Students	Mean Scores on Evaluation Devices				
	1	3	R	A	B
Program-Taught Section (Field Experiment)	45.12	92.43	73.49	56.61	299.51
Class of Normal Size Using Revised Program	44.92	85.63	70.50	56.00	292.51
Teacher-Taught Section (Field Experiment)	37.50	75.33	66.26	50.23	267.05

on the written test of knowledge of basic facts and on the three-hour performance test were approximately halfway between mean scores of the experimental and teacher-taught sections in the field experiment.

Performance of students taught by the revised program was superior to that of students in the teacher-taught sections in the field experiment. The fact that the students scored a little lower on two variables than did students in the program-taught sections of the field experiment may be due to the use of full classes rather than random halves of the classes and the fact that these students began the unit with less previous experience.

CHAPTER VII

CONCLUSIONS AND IMPLICATIONS

Conclusions which can be drawn from this study will be summarized in this section. Implications for types of self-instructional programs which are possible to develop will also be discussed.

Performance of students taught by the self-instructional program used in the study may be expected to be more consistent than that of students taught by traditional methods of teaching. The quality of the garments made by the program-taught students in the experiment was relatively consistent from school to school. On the other hand, the quality of garments constructed under the guidance of teachers varied greatly from school to school.

Performance of program-taught students was superior to that of teacher-taught students on all five variables. Since two of the tests were written at the application level of learning, students may be expected to transfer their learnings to new sewing tasks more successfully when the program is used than when the group is teacher-taught. Results of this study indicate that garments made while students are progressing through the program and garments made independently at the conclusion of classroom experiences may be more satisfactory when the program is used. These results do not mean that all garments made by students using the program will be superior to all garments made under a teacher's supervision, but that the quality of garments made by any one group using the program is likely to be superior.

This study indicates, therefore, that programs can be written which teach for understanding and ability to apply learnings to new situations. Learning from self-instructional programs is not confined to recall of specific responses called for in the program, as it was shown by the performance of the program-taught students on the tests prepared for use in this study. An effective program will show up differences even with norm-referenced tests. It is also clear that programs which guide students to develop motor skills can be written.

There was evidence that with self-instructional programs students were more willing to learn principles and generalizations as they performed the tasks in clothing construction because they had the information when they needed it. When students sew, there is a natural tendency for them to resent stopping for verbal instructions and demonstrations. They want to continue sewing and complete their own garments as rapidly as possible. They are not as interested in learning the principles of clothing construction as in completing their garments. The program required that they think about what they had read and interpret it in terms of what was happening to their garments. Because they were being guided to draw their own conclusions and make their own decisions, they did not seem to object to the amount of time spent learning the reasons as well as the techniques required for clothing construction.

Results of this study indicated that self-instructional programs can be developed which (1) teach at higher levels of learning than recall and (2) teach motor skills.

CHAPTER VIII

SUMMARY

One purpose of this project was to develop a self-instructional program which would teach a skill at the level of learning which prepares the student to transfer learnings to a new task. A further purpose was to appraise the self-instructional program developed, by means of a field experiment in which program- and teacher-taught sections of classes were compared. The program to be developed was the experimental variable in the field experiment.

The program was written during the first phase of this project. In preparation for the writing of the program, the researchers attended a two-week workshop conducted by the American Institutes for Research for the purpose of receiving training in developing self-instructional programs. Following the workshop, the sewing machine program, which had been written and revised as a part of two previous Master's studies, was revised. Work was then begun on the other two sections of the program, "The Pattern" and "Blouse Construction." Detailed behavioral objectives were written after conferences with clothing specialists and high school teachers. Reference was also made to clothing text books and guides.

Upon the completion of the first draft of the program, students from the target population participated in the cycle of student trials and revisions. Seven students completed "The Sewing Machine" and "The Pattern" sections, while six students completed "Blouse Construction." At the same time, consultants from AIR appraised the program.

The self-instructional program developed is entitled Sewing Step-by-Step. Following is a brief description of each of the three sections, the first of which was "The Sewing Machine." In this portion of the program, the student learns the names and functions of the parts of the sewing machine, as well as how to operate it. Basic principles of how the sewing machine operates have been included so that the student learns to use not only the model she used in the classroom, but also other models of machines.

The second part of the program, "The Pattern," deals with understanding and using commercial patterns. This section helps

the student select patterns and fabric, prepare the fabric, and lay, pin, cut, and mark each pattern piece.

The final portion, "Blouse Construction," guides students in the construction of a garment. An effort is made to teach principles and generalizations, as well as construction techniques, so that the student will be able to transfer these classroom learnings to out-of-class situations in which different sewing machines or patterns are used.

Unique features of the program include a series of visual and tactile aids, called panels and exhibits, to which students refer at points when it seemed important that the student see, feel, or evaluate realistic examples. An active teacher role is built into the program via "hand" frames where the students are instructed to call the teacher to check their answers or the work on their garments. A final feature is the inclusion of many illustrations which are used in both teaching and evaluation sequences.

The program was used by 57 students in the field study. The mean error rate for the total program, based on 790 responses, was 5.11 percent with a range from .51 percent to 23.04 percent. The 790 responses included all written responses and performance frames checked by the researchers.

The mean time required for the completion of the program was 24 hours, 44 minutes, or approximately 27 class periods that were 55 minutes in length.

Five criterion variables were developed by the research staff for use in the field experiment. These variables were non-referenced tests and were designed to measure not only knowledge and comprehension but also ability to apply learnings in the performance of specified tasks.

Two of the evaluation devices were paper-and-pencil tests. One was developed which measured recall and understanding of facts and principles in the program. The second one was designed to measure the attainment of objectives at the application level.

A one-hour performance test measured ability to repeat in real-life situations procedures which students had been guided to perform while they were proceeding through the program. A second performance test, a three-hour transfer test, attempted to measure the attainment of objectives at the application level. Students were asked to perform tasks which tested their ability to transfer learnings to new situations. The fifth criterion variable was a rating scale which was used to quantify judgments of quality of blouse construction.

A field experiment, conducted in six schools, was designed to compare students taught by the program with students taught by their teachers with respect to the five criterion variables, by means of a multivariate analysis. In each of six schools a class was divided into two random sections for a seven-week period. The teacher taught one section by traditional methods and a researcher supervised the other section while pupils proceeded through the program. All students in both sections, in approximately the same time, made blouses using the same pattern. Finished blouses were scored on the rating scale by trained researchers at UNC-G. The four tests were administered to both groups at the same time in the schools.

A multivariate analysis was used to study simultaneously the extent to which the five criterion variables differentiated the teacher-taught sections of the classes from the sections taught by the program. This was a two-dimensional analysis, the dimensions being (1) method of teaching, with two methods and (2) schools, with six schools. The classifications were completely crossed, both methods of teaching being used in each of six schools. The five evaluation devices were the dependent variables. The design was, therefore, a five-variate two classification factorial design.

It was clear that when the five dependent variables were considered together, there were large differences between the teacher-taught and program-taught sections in the limited sample in this study. These differences could not be due to chance factors and must be attributed to the superiority of the program as contrasted with methods used by the teacher.

Since the outcome of the multivariate tests for each hypothesis tested, i.e., methods, schools, and interaction, were significant, this implied that one or more of the dependent variables was discriminating the hypothesis in question. Each was then analyzed separately using the two-factor analysis of variance design to determine which of the variables discriminated methods of teaching, schools, and interaction. The results of this analysis showed that differences between the program-taught and teacher-taught sections on all variables were significant beyond the 1 percent level. The only source of variation that was significant on all variables was method of teaching.

Analysis of blouse scores indicated that differences among the schools were significant beyond the 1 percent level and the interaction between method of teaching and schools was significant beyond the 5 percent level. However, the magnitude of the interaction effect was small compared to the F-ratio for method of teaching which was highly significant. In spite of the significant interaction there was no doubt that the blouse score discriminated between methods of teaching.

A comparison of mean scores indicated that students taught by the program were superior to those taught by their teacher in five of the six schools and on each of the criterion variables. In the sixth school mean scores on all but one test were higher for the section taught by the program and on that test, the mean of the teacher-taught section was almost identical to the mean score of the program-taught section.

Differences between program-taught and teacher-taught sections within each school on each variable were also analyzed using the t-test. In general these t-values were significant in each school for each variable.

In summary, all five dependent variables, as well as the combination of the five variables, significantly discriminated the program-taught from the teacher-taught sections, the program-taught sections being superior in each case. The variables which most successfully discriminated between program-taught and teacher-taught sections were the blouse rating scale, one-hour performance test, and application test. The blouse score was the most sensitive measure of what was learned.

On the basis of evidence gained from the field experiment, the program was revised (1) to improve sections where error rates had been the highest, and (2) to improve sections related to test items most frequently missed. Another purpose of the revision was to make the program more general in nature so that it would be appropriate for wider use.

The revised program was used in two schools with a total of 35 students. The purpose this time was to determine the effectiveness of the program in a normal classroom situation so the classes were not divided in half. The average time required for completion of the program was 28 hours, 15 minutes. The mean error rate for the total program was 3.91 percent.

The five evaluation devices used in the field experiment were administered to the 35 students in the supplementary study. Mean scores on three of the devices--the one-hour performance test, the written application of principles test, and the blouse rating scale--were almost the same as the mean scores of students in the experimental section of the field experiment (the program-taught section). Mean scores on the written recall test and on the three-hour performance test were approximately half-way between mean scores of the experimental and teacher-taught sections in the field experiment.

REFERENCES

1. Bloom, Benjamin S. (ed.) Taxonomy of Educational Objectives, Handbook I: Cognitive Domain. New York: David McKay Company, Inc. 1956. 207p. (Reprint 1965)
2. Bock, R. Darrell. "Contributions of Multivariate Statistical Methods of Educational Research." University of North Carolina at Chapel Hill. 1963. Mimeo. 24p.
3. Glaser, Robert. "Instructional Technology and the Measurement of Learning Outcomes: Some Questions." A symposium address presented at the meetings of the American Educational Research Association, Chicago, February 1963. 7p.
4. Huffman, Sally Elizabeth. Home Economics Teachers and Programed Instruction - an Exploratory Inquiry. Unpublished Master's Thesis, University of North Carolina, Greensboro. 1963. 101p.
5. Johnson, Hildegard; Clawson, Barbara; and Shoffner, Sarah M. Sewing Step-by-Step. Boston, Massachusetts: Ginn and Company. 1967. 761p.
6. Jones, Lyle V. "Some Illustrations of Psychological Experiments Designed for Multivariate Statistical Analysis." A paper presented at a conference on Multivariate Experimentation, Allerton Park (University of Illinois), November 15, 1960. 33p.
7. Keislar, Evan R. "Programing for Transfer: A Mediational Approach." In Filep, Robert T. (ed.) Prospectives in Programing. New York: The Macmillan Company. 1963. 324p.
8. Mager, Robert F. Preparing Instructional Objectives. Palo Alto, California: Fearon Publishers, Inc. 1962. 62p.
9. Moore, Catherine Porter. Development of a Self-Instructional Program on the Sewing Machine. Unpublished Master's Thesis, University of North Carolina, Greensboro. 1963. 98p.

10. Rock, Dr. William C. "Problems of Criterion Measures Encountered in Designing a Program for Measuring the Effectiveness of Programmed Learning." A paper presented to the American Education Research Association. February 10, 1965. 6p.
11. Ross, Carolyn Elizabeth. Development of a Paper and Pencil Test and a Performance Test to Accompany a Self-Instructional Program on the Sewing Machine. Unpublished Master's Thesis, University of North Carolina, Greensboro. 1965. 82p.
12. Schramm, Wilbur. New Teaching Aids for the American Classroom. Washington, D. C.: U. S. Department of Health, Education and Welfare. Office of Education. 1962. 173p.
13. Shoffner, Sarah Moore. Revision and Field Test of a Self-Instructional Program on the Sewing Machine. Unpublished Master's Thesis, University of North Carolina, Greensboro. 1964. 140p.
14. Silberman, Harry, et al. Development and Evaluation of Self-Instructional Materials for Underachieving and Overachieving Students. Unpublished report, Title VII, NDEA, Grant Number 704137.01. July 1962. 115p.
15. Solomon, Mary M. Development of an Evaluation Device to Measure Quality of Workmanship on a Blouse. Unpublished Master's Thesis, University of North Carolina, Greensboro. 1967. 115p.
16. Taber, Julian I.; Glaser, Robert; and Schaefer, Halmuth H. Learning and Programmed Instruction. Reading, Massachusetts: Addison-Wesley Publishing Company, Inc. 1965. 182p.
17. Walker, Helen M. and Lev, Joseph. Statistical Inference. New York: Henry Holt and Company. 1963. 510p.
18. Williams, Everard M. "Innovation in Undergraduate Teaching," Science, Vol. 155, February 24, 1967. p. 974-979.
19. Zaccaria, Michael A. and Olsen, John. "Reappraisal of Achievement Measures." In Ofiesh, Gabriel D. and Meierhenry, Wesley C. (editors) Trends in Programmed Instruction. Washington: Department of Audiovisual Instruction; National Education Association; and The National Society for Programmed Instruction. 1964. 289p.

APPENDIXES

APPENDIX A

Generalizations and Objectives

GENERALIZATIONS

Generalizations for "The Pattern"

Pattern Selection, Body Measurements, and Figure Types

1. Pattern sizes and figure types are determined by body measurements, never by age or size of ready-to-wear clothes.
2. Figure types such as Teen, Junior, and Miss are designed for a body size, not an age.

Pattern Envelope

1. The pattern envelope gives information that helps the sewer decide on a pattern style and know what to buy.

Pattern Markings

1. Pattern markings are symbols used in identification of pattern pieces, placing the pattern on the fabric, and construction processes.
2. The seam allowance is the space between the stitching line and the cutting line.
3. Notches and dots are used to match seam lines.

Preparation of Fabric

1. Lengthwise threads or lengthwise grain run parallel to the selvage.
2. Crosswise threads or crosswise grain run across the fabric from selvage to selvage.
3. The ends of the fabric are straight if the crosswise thread ravel from selvage to selvage without interruption.

Laying Pattern on Fabric

1. With each pattern there is a pattern guide which shows how to place the pattern pieces on different widths of fabric, using different sizes of patterns.
2. Cutting layout diagrams show how to lay the pattern pieces on the fabric on-grain and in an economical way.
3. Grainline is correct when the ends of the grainline arrow on the pattern piece are equidistant from the selvage.

Marking

1. Pattern markings must be made on the wrong side of the fabric so they will not show in the finished garment.

Generalizations for "Blouse Construction"

Staystitching and Bridgestitching

1. Staystitching is a line of stitching done on or near the seam line on edges that are off-grain and would stretch during construction if not staystitched.
2. Staystitching is done with the grain.

Darts

1. Correctly made darts are tapered so gradually that there is no pucker on the right side.
2. Vertical darts are pressed toward the center of the garment and horizontal darts toward the hem.

Plain Seams

1. Most seams have a 5/8" seam allowance.
2. Plain seams are stitched with the right sides together.
3. Plain seams are usually pressed open to avoid bulk at the seam line.
4. Easing is a term describing "working in" extra fabric when joining two pieces of fabric, one of which is deliberately cut longer (or fuller) than the other.
5. Eased seams are pinbasted and stitched with the fuller side up.

Pressing

1. All seams and construction details are pressed before they are crossed by another seam.
2. Curved areas of garments are pressed on curved surfaces.

Facings

1. Facings are used to finish raw edges of a garment.
2. A facing and a garment unit are pinbasted and stitched with right sides together.
3. Seam allowances which do not show on the inside of the garment are trimmed to eliminate bulk.
4. Corners are trimmed to eliminate bulk.
5. Seams with inside curves are clipped to the line of stitching to allow the seam to spread and make a smooth curve.
6. Clipping is done with the points of the scissors.
7. Clipping is cutting at right angles to the seam line and trimming is cutting parallel to the seam line.
8. The purpose of understitching is to keep the facing to the underside.
9. Understitching is done on the facing and stitches the seam allowance to the facing.

10. Outside edges of facings are turned under once and stitched to prevent raveling and give a smooth finished look to raw edges.
11. Cleanfinished edges are stitched close to the fold rather than the raw edge.

Sleeves

1. Ease is evenly distributed.
2. Ease may be distributed by pulling at the same time one thread from each of two lines of stitching.
3. A right sleeve does not fit into a left armhole and vice versa.
4. The sleeve cap is a curved edge which is larger (fuller) than the armhole curve to which it will be attached.

Hems

1. Regardless of the width of the finished hem, the first turn is not more than 1/4".

OBJECTIVES FOR SEWING STEP-BY-STEP

Objectives for "The Sewing Machine"

Overall Objective

Given one of the following models of Singer sewing machines (66, 15-91, 301, 201, 404), the student is able to thread and operate that particular model.

Major Objectives

- I. Given a sewing machine, the student can locate the following parts:
- | | |
|------------------|-------------------------|
| bobbin | presser-foot lifter |
| bobbin case | slide plate |
| bobbin winder | spool pin |
| feed dog | stitch-length regulator |
| foot control | stop-motion screw |
| hand wheel | tension regulator |
| knee control | thread cutter |
| needle | thread guides |
| needle bar | thread take-up |
| presser foot | treadle |
| presser-foot bar | |
- II. Given a sewing machine, the student can use the following parts:
- | | |
|-----------------------------------|-------------------------|
| bobbin | slide plate |
| bobbin case | spool pin |
| bobbin winder | stitch-length regulator |
| foot, knee, or
treadle control | stop-motion screw |
| hand wheel | tension regulator |
| needle | thread cutter |
| presser foot | thread guides |
| presser-foot lifter | zipper foot |
- III. The student is able to differentiate among the functions of the following sewing machine parts:
- | | |
|-------------------------|-------------------|
| feed dog | bobbin case |
| hand wheel | tension regulator |
| presser foot | thread guides |
| stitch-length regulator | stop-motion screw |
| thread take-up | |

Behavioral Objectives

Given a sewing machine, the student is able to:

1. differentiate between electric and treadle sewing machines
2.
 - a. locate the foot or knee control
 - b. press the foot or knee control
3. locate the spool pin
4.
 - a. locate the various thread guides
 - b. thread the various thread guides by snapping or hooking threads into them
 - c. recognize that all thread guides have a common function, to hold the thread in place
5.
 - a. locate the tension regulator
 - b. locate the wire spring and the thread guide which are attached to the tension regulator
 - c. thread the tension regulator so that the thread is between the discs and into the wire spring and the thread guide
 - d. recognize that the function of the tension regulator is to control the tightness of the thread
6.
 - a. locate the thread take-up
 - b. thread the thread take-up
 - c. recognize that in threading all sewing machines the thread is first put into the tension regulator and then through the thread take-up
 - d. recognize that the function of the thread take-up is to pull the thread to make a stitch
 - e. differentiate between thread guides and the thread take-up
7.
 - a. locate the presser foot
 - b. recognize that the function of the presser foot is to hold the fabric in place
8. locate the presser-foot bar
9.
 - a. locate the presser-foot lifter
 - b. use it to lower and raise the presser foot
 - c. use the right hand, keeping it under the arm of the machine, to raise and lower the presser-foot lifter
10.
 - a. locate the feed dog
 - b. recognize that the function of the feed dog is to move the fabric along with each stitch

11.
 - a. locate the hand wheel.
 - b. recognize that the function of the hand wheel is to start and stop the machine.
 - c. use the hand wheel to start and stop the machine by turning it toward the operator.

12.
 - a. locate the slide plate.
 - b. move the slide plate to gain access to the bobbin and the bobbin case.

13.
 - a. locate the bobbin case.
 - b. differentiate between the two types, those that can be taken out of the machine and those that cannot be taken out
 - c. locate the bobbin.
 - d. recognize that the function of the spring on the bobbin case is to control the tension on the bobbin thread.
 - e. after raising the needle to its highest point, place the bobbin in the bobbin case so that the bobbin turns in the direction correct for the particular machine and the thread is in the slot and under the tension spring

14.
 - a. locate the stop-motion screw.
 - b. recognize that the function of the stop-motion screw is to keep the needle from going up and down while the bobbin is wound.
 - c. loosen the stop-motion screw by turning it toward you.
 - d. tighten the stop-motion screw by turning it away from you.

15.
 - a. locate the bobbin winder, the bobbin spindle, and the projection on the spindle.
 - b. wind a bobbin by following this procedure:
 - (1) loosen stop-motion screw by turning it toward you.
 - (2) place the empty bobbin on the bobbin spindle so that the smallest hole in the bobbin fits the bobbin spindle projection.
 - (3) place the spool of thread on the bobbin spool pin, put the thread under the thread guide and through the hole on the left side of the bobbin from the inside out.
 - (4) push bobbin winder against the hand wheel.
 - (5) pull end of thread and slowly start the machine.
 - (6) pull the bobbin winder away from the hand wheel.
 - (7) remove the bobbin and cut the thread half-way between the spool of thread and the bobbin.

16.
 - a. locate the needle
 - b. thread the needle so the thread enters the "eye" of the needle from the side of the last thread guide.

- c. recognize that a sewing machine needle is always threaded from the side of the last thread guide
17. thread the upper parts of the sewing machine in the following order:
- | | |
|-----------------------|--------------------|
| (1) spool pin | (4) thread take-up |
| (2) thread guides | (5) thread guides |
| (3) tension regulator | (6) needle |
- (Review for this objective is done at various stages in the program.)
18. bring the bobbin thread through the hole in the throat plate by:
- holding the thread loosely in the left hand.
 - turning the hand wheel toward you one turn and stopping when the needle reaches the highest point.
 - pulling on the upper thread until the bobbin thread loops.
 - continuing to pull on loop until the end of the bobbin thread comes out of the needle hole.
19. begin stitching without tangling the threads by:
- pulling the upper thread between the "toes" of the presser foot and away from you.
 - by putting the bobbin thread toward the back with the upper thread.
20. begin stitching by:
- placing fabric under the presser foot so the bulk of the fabric is to the left of the needle.
 - turning the hand wheel toward you until the thread take-up and the needle are both at their highest points.
 - lowering the needle by turning the hand wheel toward you
 - lowering the presser-foot lifter
 - placing left hand on the fabric behind the presser foot and the right hand in front of the presser foot.
 - turning the hand wheel toward you and starting slowly by pressing lightly on the foot or knee control.
- (This is done at various stages without fabric and then with fabric.)
21. stop stitching by:
- stopping 1/4" from the edge of the fabric.
 - using the hand wheel for last two or three stitches
 - stopping with the needle and the thread take-up at their highest points.
 - raising presser-foot lifter
 - removing fabric by pulling it toward the back of the machine

- f. pulling the fabric about three inches away from the machine and cutting the thread near the fabric.
22.
 - a. locate the thread cutter.
 - b. use the thread cutter to cut the threads after stitching a seam.
 23.
 - a. locate the stitch-length regulator.
 - b. recognize that the function of the stitch-length regulator is to change the length of the stitches and the direction of stitching.
 - c. use the stitch-length regulator to change the length of the stitch by:
 - (1) turning the screw to the left to unlock the lever
 - (2) pushing the lever up or down to a given number
 - (3) turning the screw to the right to lock the stitch-length regulator.
 - d. use the stitch-length regulator to reverse the stitching direction by moving the lever to its highest point.
 24. recognize that 12-15 stitches per inch are recommended for most medium weight fabrics
 25.
 - a. make a line of stitching with 6-8 stitches per inch.
 - b. make a line of stitching with 12-15 stitches per inch.
 - c. differentiate between size 6-8 and 12-15 stitches per inch.
 - d. recognize that the larger the number on the stitch-length regulator the smaller the stitches.
 26. recognize that
 - a. the upper and lower tensions are regulated properly when the stitching looks the same on both sides of the fabric.
 - b. the upper tension is too tight when the threads lock on the upper surface of the fabric.
 - c. the upper tension is too loose when threads lock on the lower surface of the fabric
 27.
 - a. adjust the tension regulator by turning the knob to:
 - (1) a larger number if the tension is too loose on the upper thread
 - (2) a smaller number if the tension is too tight on the upper thread
 - b. recheck before adjusting the tension:
 - (1) sequence of threading upper parts of the machine
 - (2) threading of the needle
 - (3) threading of the bobbin case
 28.
 - a. locate needle bar
 - b. locate screw on the needle bar
 - c. remove the needle by loosening the screw on the needle bar.

29. recognize that the needle is in correctly when the long groove is on the side of the last thread guide.
30. replace the needle by:
 - a. lowering the needle into the hole in the needle plate.
 - b. turning the needle until the long groove of the needle is on the last thread guide.
 - c. raising the needle as far as it will go into the opening for the needle in the needle bar.
 - d. tightening the needle screw on the needle bar.
31. stitch a square corner by:
 - a. stopping at the corner with the needle down.
 - b. lifting the presser foot.
 - c. turning the fabric so the raw edges are against the same guide line before turning the fabric.
 - d. lowering the presser foot and continuing to stitch.
32. use the stitch-length regulator to reverse the direction before backstitching 1/2 inch from each end of the seam.
33. remove the presser foot and attach a zipper foot by:
 - a. unscrewing the large screw on the presser-foot bar and slipping the presser foot out.
 - b. attaching the zipper foot where the presser foot was removed and tightening the screw on the presser-foot bar.
34. remove machine cord from wall and machine receptacles by grasping the plug.
35. recognize basic sewing machine parts as they look on several models of sewing machines.
36. arrange names and show threading of the basic parts of the sewing machine in the correct sequence.
37. recognize that the number and position of thread guides varies on different models of sewing machines.
38. recognize when the wire spring and thread guide on the tension regulator are threaded correctly.

Objectives for "The Pattern"

Pattern Selection, Body Measurements, and Figure Types

- A. The student recognizes that:
 1. patterns are designed for different figure types and sizes

2. figure types such as girls, teens, juniors, misses, women's, and half-sizes are designed for a body size, not an age.
 3. pattern companies have different names for figure types
 4. figure types are determined by the proportions (relationship among such measurements as bust, waist, hip, and height) of body measurements.
 5. there is one figure type which is most appropriate for each person.
 6. figure type and size must be considered when selecting a pattern.
 7. buying the size and type of pattern with measurements closest to her own makes many alterations unnecessary.
- B. Given a tape measure, pencil, paper, and a partner, the student:
1. recognizes that pattern sizes are determined by body measurements, never by age or sizes of ready-to-wear clothes
 2. takes measurements over a slip and foundation garments usually worn.
 3. takes her partner's bust measurement
 - a. places the tape measure over the fullest part of the bust, directly under the arms, and straight across the back
 - b. records bust measurement.
 4. takes her partner's back waist length measurement
 - a. places end of the tape measure at the prominent bone at the back base of the neck and measures to the waistline
 - b. records back waist length.
- C. Given a chart of figure types and sizes, the student:
1. selects a pattern of the appropriate figure type and size by:
 - a. referring to a chart of figure types
 - b. considering back waist length and bust measurements

Pattern Envelope

- D. Given the pattern envelope of a blouse pattern, the student locates:
1. front of envelope
 - a. locates pattern size, bust measurement and figure type
 - b. locates the different views of the pattern
 - c. recognizes that any of the views on the pattern envelope can be made with this pattern.

2. back of envelope
 - a. locates the different back views of the pattern
 - b. locates table of fabric yardage required for various views, sizes, and widths of fabric
 - (1) selects the yardage for a particular width of fabric (36"-45"), size, and view
 - c. locates fabric suggestions
 - d. locates list of notions
 - (1) recognizes that it is difficult to tell from a picture what notions will be needed
 - (2) lists the notions that will be needed to make any of the views shown on the pattern envelope

E. The student recognizes that it is an economical use of time, energy, and money to buy pattern, fabric, and notions at one time.

Pattern Markings

- F. Given a pattern piece with the following pattern markings, the student:
1. recognizes that pattern markings are symbols used in identification of pattern pieces, laying out pattern on fabric, and construction processes.
 2. identifies identification markings
 - a. the name of the pattern piece
 - b. the pattern size
 - c. the pattern number
 - d. number indicating the view for which it is being used.
 3. identifies layout markings
 - a. grain line
 - b. "place this line on fold of fabric" or "place on fold"
 4. identifies pattern construction markings
 - a. notch
 - b. cutting line
 - c. stitching line
 - d. seam allowance
 - e. directional arrows
 - f. darts (short broken lines--stitching line for darts)
(solid line in the center of dart--fold line)
 - g. dots
 - h. buttonholes
 - i. hemline
 - j. center front line
 - k. facing fold line.

Preparation of Fabric

- G. Given a piece of fabric, the student:
1. identifies the selvage edge of the fabric
 2. recognizes that lengthwise threads or lengthwise grain runs parallel to the selvage edge
 3. identifies the cut or torn edge of the fabric
 4. recognizes that the crosswise threads or crosswise grain runs across the fabric from selvage to selvage
 5. tests for straightness of ends of fabric
 - a. pulls a crosswise thread at each end of the fabric to test for straightness
 - b. recognizes that the ends are straight if the crosswise thread ravel from selvage to selvage
 6. straightens the ends of the fabric if cut from the bolt
 - a. snips the selvage on the short side and works out the end of a crosswise thread
 - b. pulls the thread all the way across the cut or torn edge of the fabric
 - c. cuts across fabric following the line left by the removal of the thread
 7. folds the fabric lengthwise, selvages together and checks to see if the cut ends form a right angle
 8. straightens the fabric if the cut ends are not parallel
 - a. gently pulls on the true bias every few inches in the direction of the short ends
 - b. folds fabric lengthwise with selvages together; if cut ends are still not parallel repeats the above process

Laying Pattern on Fabric

- H. Given a pattern guide sheet and fabric, the student:
1. locates cutting layouts for all sizes
 2. recognizes that cutting layout diagrams show how to lay the pattern pieces on the fabric on grain and in an economical way
 3. selects the cutting layout diagram for a particular width of fabric, size, and view to be used in class

4. recognizes that the possible folds are
 - a. lengthwise--fabric folded with selvages together
 - b. crosswise--fabric folded with cut ends together
 - c. combination of lengthwise and crosswise
 - d. fabric unfolded.
5. folds fabric as indicated on a particular cutting layout diagram.
6. removes from the pattern envelope all pattern pieces needed for any view shown.
7. places pattern pieces on the fabric as one of the cutting layout diagrams suggest.
8. recognizes that placing all pattern pieces for the desired view on the fabric at one time is a safeguard against failing to allow space for some pattern pieces.
9. places the grain line of any pattern piece on the grain of the fabric as suggested by the guide sheet
 - a. recognizes that a garment must be cut on grain to hang correctly
 - b. measures from each end of the pattern grain line to the nearest selvage
 - c. recognizes that the grain line is correct when the ends of the grain line arrow on the pattern piece are equidistant from the selvage.
10. pins the pattern pieces in place
 - a. places the first two pins at the ends of the grain line mark
 - b. recognizes that slipping of the pattern piece results in incorrect grain lines
11. smooths the pattern piece in all directions, and pins at corners, then puts in additional pins to hold pattern securely.
12. places pins perpendicular to the seam line.

Cutting

- I. Given a garment unit which is ready to be cut, the student:
 1. recognizes that accuracy of cutting greatly affects the fit and appearance of the finished garment.
 2. recognizes that cutting is done correctly by
 - a. using sharp cutting shears

- b. cutting on cutting line
- c. cutting off the margin of the pattern (extra paper outside the cutting line) along the cutting line as the fabric is cut
- d. opening shears wide each time and cutting with long even strokes on straight edges (to insure a smooth edge)
- e. using short strokes and points of shears for short spaces
- f. not lifting or moving pieces while cutting
- g. holding the pattern and fabric in place while cutting by placing one hand on the pattern and fabric beside the area being cut
- h. cutting notches outward from the pattern in triangles.

Marking

- J. Given a cut garment unit with the pattern attached, the student:
- 1. recognizes the pattern markings she will need to transfer to the fabric for use in constructing the garment
 - a. darts
 - b. center front (at neckline and bottom edge)
 - c. seam line or curved edges
 - (1) armseye
 - (2) sleeve cap between notches
 - (3) neckline
 - d. center of sleeve cap
 - e. facing fold line at neckline and bottom edge.
 - 2. places a padding (magazine, newspaper, cardboard) directly under the section to be marked (to prevent marring the table).
- K. Given a selection of dressmaker's carbon paper, the student:
- 1. selects a color of dressmaker's carbon paper which is one shade darker or lighter than the fabric to be marked.
 - 2. identifies the "chalky" side of the tracing paper as the side that will leave a mark.
 - 3. recognizes that pattern markings must be made on the wrong side of the fabric, so they will not show in the finished garment.
 - 4. places the "chalky" side of carbon paper against the wrong side of the fabric.
- L. Given a tracing wheel and a ruler, the student:
- 1. traces the necessary markings with a single stroke (so there will be only one line to follow) using the amount of pressure necessary for the markings to show on both sides.

2. uses the ruler as a guide for accurate marking of straight lines.
3. marks a small crosswise line where lines end or converge, such as at dart points, to show exactly where stitching should stop.

Objectives for "Blouse Construction"

Staystitching

- A. Given any garment, the student decides upon:
 1. the edges which require staystitching
 - a. Staystitching is done on edges that are off grain and stretch during construction if not staystitched.

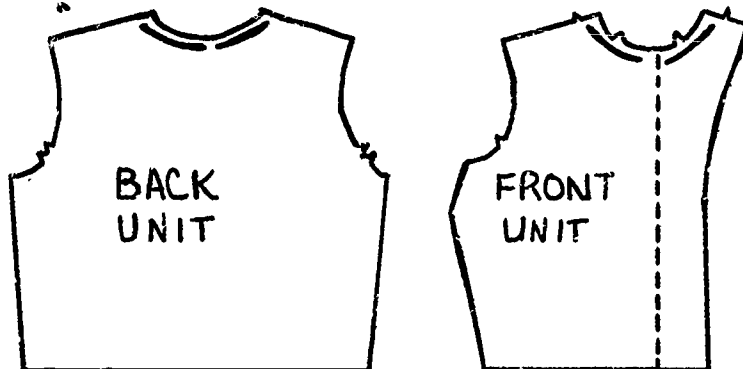

2. the correct distance of the staystitching from the edge of the garment unit.
 - a. Staystitching is a line of stitching $1/8$ " from the marked seam line toward the cut edge of the garment unit.
 - b. Staystitching is done within the seam allowance.
3. the correct directions for staystitching.
 - a. One method of determining the direction of staystitching is to run your finger along the cut edge of the fabric. If threads are stroked down or smooth, you are going with the grain--the correct direction for staystitching. If the threads rough up, you are going against the grain--the wrong direction for staystitching.
 - b. The correct direction for staystitching a blouse or bodice of a dress is

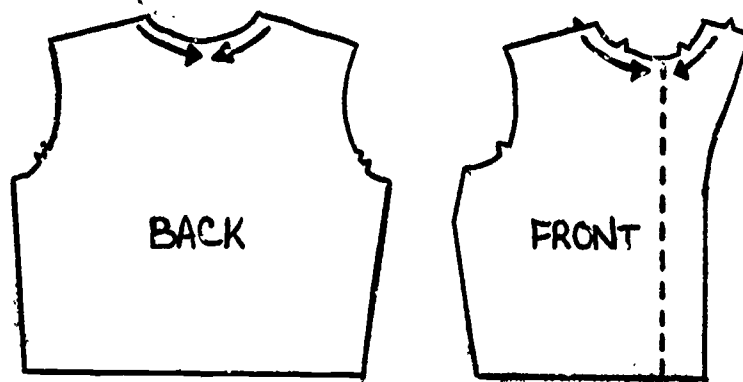

c. The arrows printed on the seam line of the pattern pieces can serve as a guide to staystitching.

B. Given any garment unit, the student locates:

1. the edges which require bridgestitching.
 - a. Bridgestitching is done to form a line on which to turn a hem on the free edges which will later be cleanfinished or hemmed.

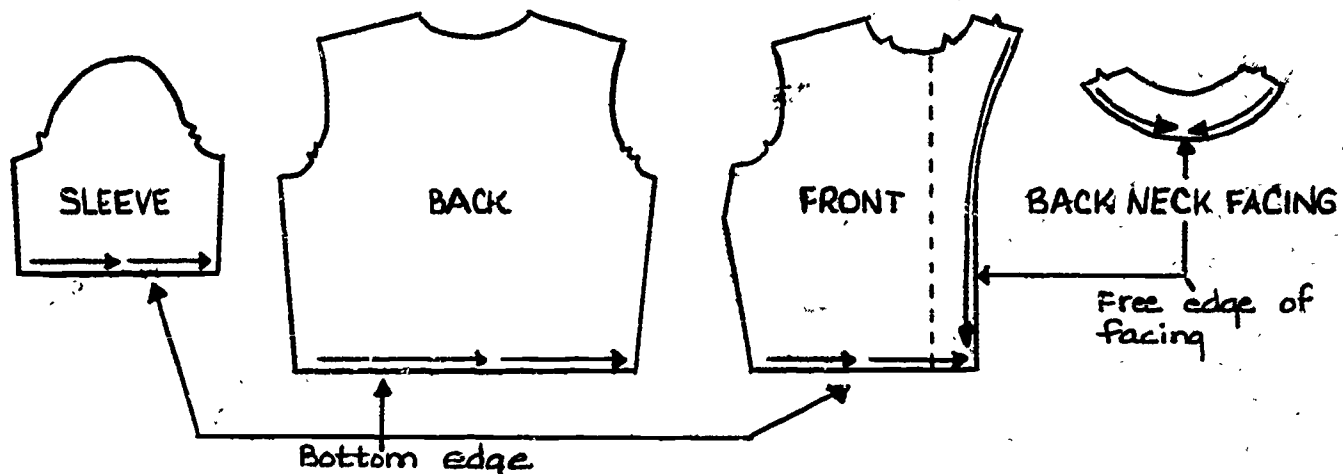

2. the correct distance of the bridgestitching line from the edge of the garment unit.
 - a. Bridgestitching is done 1/4" from the cut edge of the fabric.

C. Given any garment unit, the student differentiates between bridge-stitching and staystitching.

D. Given a garment unit from which the pattern has been removed, the student staystitches and bridgestitches by using the following procedure:

1. sets the stitch-length regulator for 12-15 stitches per inch
2. places the cut edge of the fabric against the stitching guide on the machine when bridgestitching
3. uses the marked seam line as a guide when staystitching
4. keeps the bulk of the fabric to the left of the needle except when staystitching
5. stitches through a single thickness of fabric
6. trims the threads but does not secure them

Darts

E. Given a garment unit with marked dart lines, the student:

1. recognizes that a dart is usually a fold of fabric, wide at

one end and tapering to a point at the other, which fits flat fabric to curves of the body.

2. identifies the dart markings
 - a. the fold line is the center line of the three lines
 - b. the stitching lines are the two outside lines
3. pinbastes a dart for stitching
 - a. folds the fabric on the fold line with the right (unmarked) sides together
 - b. holds the fabric so the wide end of the dart is in the left hand
 - c. pinbastes on the stitching line from the widest part of the dart to the point by placing pins with points toward the left hand
 - d. checks to see that pins hit both lines
4. stitches a dart
 - a. places the widest part of the dart under the presser foot
 - b. stitches exactly on the marked line tapering off to nothing at the point
 - c. uses the right hand on the hand wheel for the last three stitches
 - d. secures the threads at the point of the dart by tying a knot
5. recognizes that curved areas of a garment (darts) are shaped on a pressing cushion which is usually a firm curved pad
6. presses a dart
 - a. places the point of the dart over the curve of the pressing cushion
 - b. presses on the wrong side of the garment with steam and the flat forepart of the iron
 - c. presses darts before they are crossed by a seam
 - d. presses vertical darts toward the center of the garment
 - e. presses a horizontal dart toward the hem

Plain Seam

- F. Given two garment units which are ready to be joined, the student:
1. pinbastes a plain seam
 - a. places the right sides of the fabric together
 - b. matches seams at the seam line and not the cut edge
 - c. pins the seam ends first and then matches and pins at the notches
 - d. places pins at right angles to the seam line

- e. places pins so the pin goes into the fabric on one side of the seam line and comes out on the other side.
2. stitches a plain seam
 - a. uses 12-15 stitches per inch
 - b. uses thread which matches the fabric
 - c. checks the tension to be sure it is correct for the fabric
 - d. places cut edge against 5/8" seam guide
 - e. stitches with the grain
 - f. secures threads by backstitching at the beginning and end of a seam (for procedure, refer to sewing machine objectives).
- G. Given a garment unit with a plain seam, the student:
1. presses a plain seam
 - a. presses a plain seam on a flat surface
 - b. presses on a line of stitching using the point of the iron
 - c. presses most plain seams open with the seam allowances separated and lying flat against the garment on either side of the seam.
- H. Given two pieces of fabric, one of which is slightly fuller than the other, the student:
1. recognizes that easing describes "working in" the extra fabric when joining two pieces of fabric, one of which is deliberately cut longer than the other
 2. pinbastes an eased seam
 - a. holds pieces of fabrics with the fuller side up
 - b. matches edges, notches and center of seam, distributing the extra fabric equally on either side of the center.
 3. stitches an eased seam with the fuller side up and manipulates the extra fullness with the fingers so that no gathers or small tucks are formed.

Pressing

- I. Given a steam iron, the student sets it for pressing cotton.
- J. Given a sample of cotton fabric, the student tests it for the effects of pressing.
1. Because thermostats vary on different irons, a sample should be tested to see that it does not scorch.
- K. Given garment pieces of cotton fabric, the student:
1. differentiates between pressing and ironing

- a. Pressing is accomplished by alternately lifting and lowering the iron, using the point of the iron and steam.
 - b. Ironing is accomplished by moving the iron back and forth in long strokes with pressure.
2. presses all seams and construction details before they are crossed by another seam.
 3. presses efficiently by pressing two or more completed units in one trip to the pressing center.

Facings

- L. Given the garment units for a blouse, the student:
1. recognizes that a facing is either a separate piece of fabric used to finish the raw edges of a garment or a turnback used to reinforce closing edges.
 2. recognizes that a fitted facing is a separate unit cut the same shape as and on the same grain as the outer section to be faced.
 3. recognizes that an extended facing is an extension of a straight edge and is cut in one piece with the outer garment section.
- M. Given a blouse front with an extended facing and back neck facing, the student:
1. pinbastes and stitches the fitted back neck facing to the extended front facing at the shoulders with right sides together and with notches matching.
 2. eliminates bulkiness by trimming the seam to 1/4".
 3. presses the seam open.
- N. Given a complete neck and front facing unit, the student:
1. recognizes that cleanfinishing is a method for preventing raveling and giving a smooth finished look to frayed edges
 2. recognizes that all free edges of facings are cleanfinished
 3. presses a crease for a cleanfinished edge along the 1/4" bridgestitch line
 4. topstitches a cleanfinished edge
 - a. places the turned back edge up toward the presser foot
 - b. places the fold of the fabric against (but not under) the inside edge of the small toe of the presser foot

- c. stitches approximately $1/8$ " from the fold using 12-15 stitches per inch.

Attaching Facings

0. Given a garment unit and the appropriate facings, the student:
 1. pinbastes a fitted facing to a curved edge
 - a. places the right side of the facing against the right side of the bodice
 - b. matches notches and shoulder seams as pinbasting is done observing that the facing fits
 - c. places pins on the garment side
 2. joins fitted facing to a curved edge
 - a. stitches from the garment side on the marked seam line
 - b. recognizes that inside seams are trimmed to eliminate bulk
 - c. trims both seam allowances
 - (1) seam allowances are trimmed to $1/4$ "
 - (2) trimming is cutting away part of the seam allowance parallel with the seam line
 - d. clips seam allowance
 - (1) recognizes that clipping is done around an inside curve to allow the seam to spread and make a smooth curve
 - (2) makes straight cuts with the points of the scissors through the staystitching line but not through the seam line
 - (3) clips approximately every $1/2$ " or as much as is needed to allow the seam to spread
 - (4) differentiates between clipping and trimming.
 3. Understitches an attached facing to the seam allowances
 - a. uses 12-15 stitches per inch
 - b. recognizes that a facing should not show on the right side
 - c. recognizes that the purpose of understitching is to keep the facing to the underside and sharpen the seam edge
 - d. understitches on the right side of the facing close to the seam line, starting and stopping about an inch from the ends
 - e. keeps both seam allowances under the facing
 - f. flattens the seam with gentle pressure of the fingers
 - g. stitches with the inside edge of the large toe of the presser foot on the seamline
 - h. pulls threads to the inside at each end
 - (1) pulls one of the loose threads at one end until a tiny loop of the thread on the opposite side appears
 - (2) catches the loop with a pin and pulls the thread through the fabric so that both threads are on the same side

4. joins an extended front facing to the garment at the hem line
 - a. folds and pinbastes the extended front facing to the outside of the garment, right sides together, at the fold line
 - b. stitches across the bottom at the hem line and backstitches at both ends
 - c. trims seam to 1/4" and stops cutting 1/4" from the clean-finished edge of the facing
 - d. continues trimming the facing portion through the clean-finished edge
 - e. trims corner to eliminate bulk
 - f. turns the facing to the inside and presses.

5. anchors the facing to the garment at the shoulder seam
 - a. recognizes that the purpose of anchoring is to keep the cleanfinished edge firmly in place at points where there is a seam
 - b. pins the facing to the garment shoulder seams
 - c. tacks the facing only to the shoulder seam allowance with matching thread

Sleeves

- P. Given a garment unit and a sleeve ready to be joined, the student:
1. recognizes that the sleeve cap is a curved edge which is fuller than the armhole curve to which it will be attached.
 2. recognizes that the ease must be adjusted before joining the two curves.
 3. stitches ease threads in sleeve cap
 - a. sets stitch-length regulator at 8-10
 - b. begins at the notch and stitches on the marked seam line to the notch on the opposite side
 - c. makes a second row of stitching 1/4" from the seam line placing the outside edge of the long toe of the presser foot on the first line of stitching
 - d. leaves two inches of thread at each end of the stitching lines
 4. joins the sleeve seams and side seams of blouse with 5/8" seam and presses open
 5. pinbastes sleeve to armhole at sleeve cap.
 - a. matches sleeve seam to blouse side seam with right sides together and pinbastes
 - b. matches notches on each side and pins
 - c. matches center of sleeve cap and shoulder seam.

6. adjusts the ease
 - a. starts at one notch and pulls one thread from each line of stitching at the same time
 - b. distributes the ease until the sleeve fits the armhole from the notch to the center of the sleeve and pinbastes-- starts at the other notch, pulls threads and distributes ease in the other half of the sleeve cap.
 - c. continues pinbasting sleeve into armhole distributing ease evenly between the notches
 - d. recognizes that there is ease in the underarm portion of the sleeve as well as in the sleeve cap
 - e. distributes ease between the notches and underarm seam and pinbastes matching seam lines.

7. recognizes that it is necessary to match notches, center of sleeve and seams in order to keep the lengthwise grain of the sleeve perpendicular to the floor and the crosswise grain parallel to the floor.

8. joins sleeve to armhole
 - a. sets stitch-length regulator between 12-15
 - b. stitches with the sleeve side up starting near the underarm seam
 - c. keeps ease evenly distributed so as to avoid formation of pleats or tucks while stitching
 - d. stitches on the first easing line (marked seam line) with the sleeve side up toward the presser foot
 - e. secures threads by continuing several stitches beyond starting point.

9. finishes the armhole
 - a. stitches the seam allowance together $1/4$ " from the seam allowance between the notches
 - b. clips to the line of stitching between the notches.

Hems

- Q. Given sections of fabric which have been bridgestitched, the student:
 1. recognizes that a hem line is a line where the hem is folded up
 2. recognizes that hems vary in width but that the first turn is not more than $1/4$ ".
 3. presses a crease on the line of bridgestitching.
 4. presses the hem up
 - a. uses a ruler (or some measuring device) in turning up the width of hem indicated on the pattern.

5. pinbastes the hem
 - a. places pins perpendicular to the hem.

6. topstitches a straight hem
 - a. places fabric under the presser foot so that the inside edge of the long toe is against, but not on, the fold
 - b. begins and ends stitching at the edge of the front facings
 - c. backstitches at both ends

7. topstitches a tubular hem
 - a. works from the inside of the sleeve with the sleeve turned right side out
 - b. places the fabric on the machine with the inside edge of the long toe of the presser foot against, but not on, the fold
 - c. lowers the needle at a point close to, but not on, the seam line
 - d. turns the garment keeping about two inches of fabric straight under the presser foot
 - e. secures the stitches by stitching one inch past the starting point

APPENDIX B

Selected Frames from Sewing Step-by-Step

SAMPLE FRAMES FROM SEWING STEP-BY-STEP*

"The Sewing Machine"

The following series of frames were taken from "The Sewing Machine." Frames 11-16 and 56-61 were selected as examples of:

1. the use of colored frames for different models of sewing machines (11 and 16)
2. the use of the 8" x 11" sewing machine diagram to aid students in locating parts of the sewing machine (14-15)
3. the combination of teaching not only location and use, but also the function of a part of the sewing machine (11-16 and 56-61)

11
Different machines have different numbers of thread guides. Thread guides on your machine are indicated by "*" on this illustration.

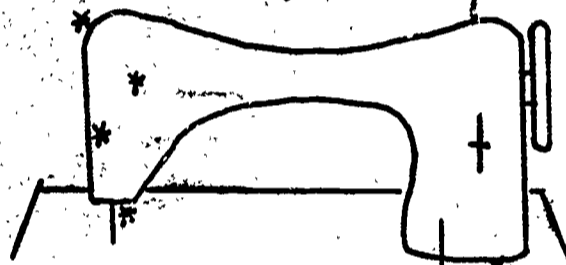

(colored paper used for this frame)

12
The purpose of these thread guides is to hold the thread in place. Thread guides hold the
** _____.

ans.
thread in place

13
Even though different machines have different numbers of thread guides, the purpose of all thread guides is to (pull/hold) _____ the thread in place.

ans.
hold

14
As the thread comes from the spool pin it is placed in thread guide #1. Locate this thread guide on the diagram.

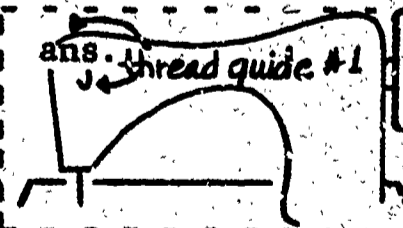

*Reprinted from Sewing Step-by-Step by Johnson, Clawson, and Shoffner by permission of Ginn and Company. Copyrighted 1967.

Checking with the diagram, locate the first thread guide on the sewing machine.

15

ans.

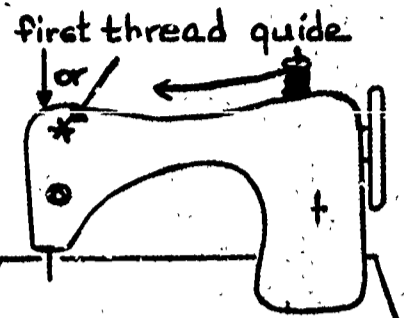

On every machine, after the thread has been placed on the spool pin, it must be snapped, hooked, or placed, not threaded, through a thread guide.

16

Snap, hook, or place the thread into thread guide #1.

THREADING--INCORRECT

SNAPPING OR HOOKING--
CORRECT



(colored paper used
for this frame)

The feed dog is a little plate with "teeth".
The little plate with teeth is the * _____

56

ans.

feed dog

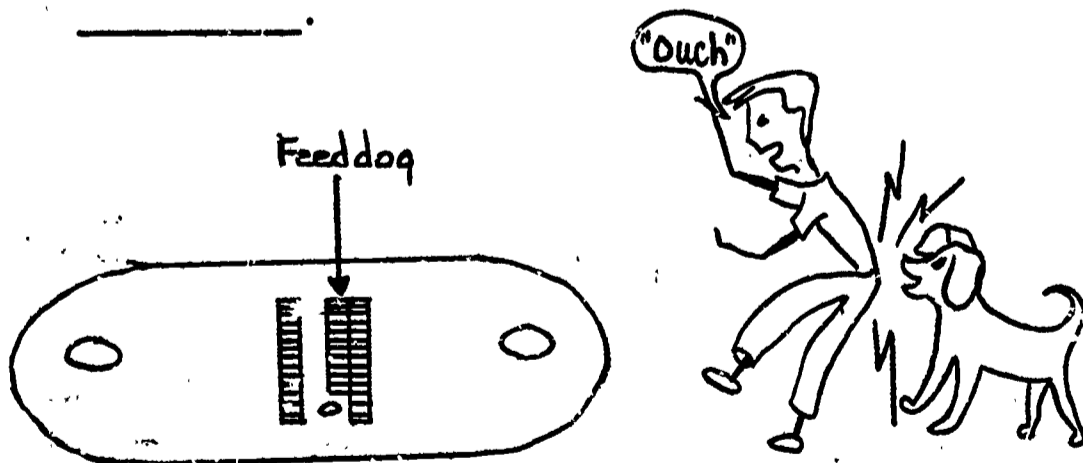

The feed dog is located directly under the presser foot. Find the feed dog on the machine.

57

ans.

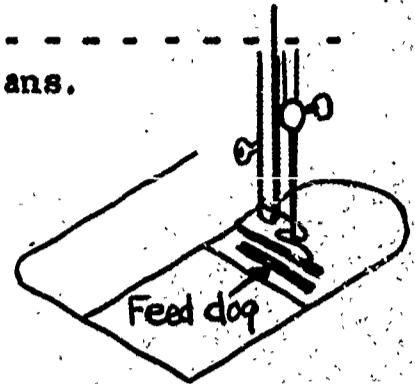

Just as an escalator moves people along, so the feed dog _____ fabric along.

58

ans.

moves

The presser foot (holds/moves _____ the fabric and the feed dog (holds/moves _____ the fabric.

59

ans.

holds
moves

Fill in the blank with the number of the part.

60

ans.

_____ presser-foot bar

_____ feed dog

_____ presser foot

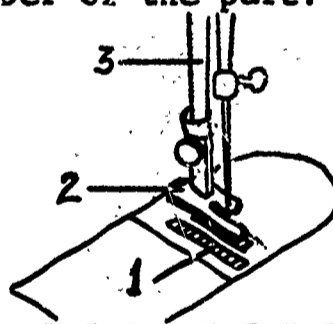

3 presser-foot bar
1 feed dog
2 presser foot

Match these parts with their functions:

61

ans.

_____ thread take-up

_____ feed dog

_____ presser foot

A. holds the fabric

B. pulls the thread to help make a stitch

C. moves the fabric

D. holds the thread in place

B

C

A

"The Pattern"

The frames reproduced are from the "Marking" section of "The Pattern" part of the program. The frames selected are examples of those which:

1. help the student to understand the process and then to perform that particular process on her own garment (20-35)
2. include references to panels and exhibits (20-24, 27)
3. include "hand" frames (31, 35)
4. include a deductive teaching sequence (20-22).

The carbon paper selected should be one which
can be seen on the wrong side but does not show
through on the right side of the fabric.

20

ans.

REFER TO PANEL 33, FIGURE I.

Which samples were marked with carbon paper of
the correct color?

_____ A _____ B _____ C

C

Panel 33, Figure II.

21

ans.

Why would the carbon paper selected for A not be
a good choice? ** _____

It is the same
color and markings
would not show.

Would the paper selected for B be a wise choice?

No, it is too dark
and would show
through the fabric
on the right side.

_____ yes _____ no Why?* _____

REFER TO PANEL 34, FIGURE I.

22

ans.

Which piece of dressmaker's carbon paper would be
the best for this fabric sample?

A

_____ A
_____ B
_____ C

Go to EXHIBIT 5.

Place the "waxy" colored side of the paper against the fabric. Mark a line with the tracing wheel.

Now place the white side of the paper against the fabric and mark another line with the tracing wheel.

Which side(s) of the paper left lines on the fabric?

_____ "waxy" _____ white

23

ans.

"waxy"

Markings made with a tracing wheel and carbon paper should be made on the wrong side of the fabric so they will not show in the finished garment.

In PANEL 34, FIGURE II, which of the samples was marked correctly?

_____ A _____ B

24

ans.

B

Pattern markings are transferred to the fabric by placing

- _____ 1. the "waxy" side of the paper against the right side of the fabric
- _____ 2. the "waxy" side of the paper against the wrong side of the fabric
- _____ 3. the white side of the paper against the wrong side of the fabric

25

ans.

2. the "waxy" side of the paper against the wrong side of the fabric

To save time the carbon paper is folded and inserted so that both halves of the garment piece are marked at the same time.

What is done to the carbon paper so that both halves of the garment piece are marked at the same time? ** _____

26

ans.

the carbon paper is folded (with the waxy side out)

REFER TO PANEL 35.

27

Examine Figures A, B, and C carefully.

1. What would happen if you traced the seam line in Figure B? ** _____.
2. What would happen if you traced the seam line in Figure A? ** _____.
3. What would happen if you traced the seam line in Figure C? ** _____.

ans.

1. marking wouldn't show on both parts
2. marking would show on both parts
3. marking would not show on either side

When a pattern piece is being traced, a pad of cardboard should be placed between the table and the fabric to prevent marring the table.

28

Get a pad of cardboard and a tracing wheel. Pick out carbon paper suitable for your garment from the supply table.

Use a scrap of your fabric.

1. Insert the folded carbon paper between two thicknesses of fabric so that it will mark both pieces at one time.
2. Practice marking until you have discovered how much pressure it takes to mark both halves of the garment without going over the line a second time. (This is called a single stroke.)

29

A ruler is used as a guide for accurate marking of a straight line.

Practice marking along the edge of a ruler with a single stroke.

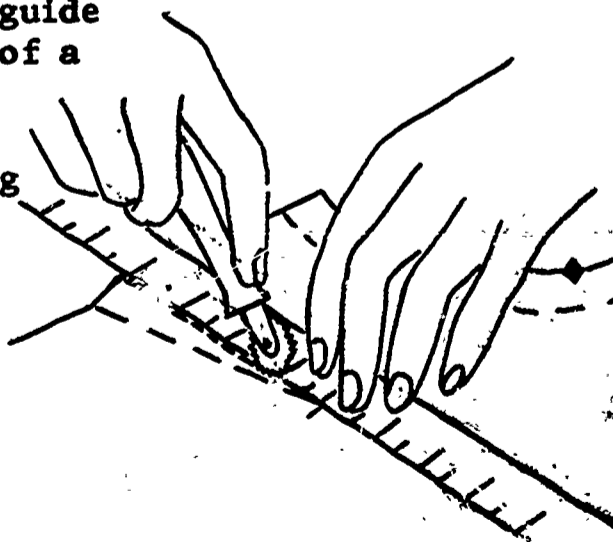

30

ans.

Can you make straight lines?

Remove only the pins above and below the dart. Insert the carbon paper.

Call the teacher.

Mark the dart on the blouse front. At the narrow end of a dart make a small crosswise line with the tracing wheel.

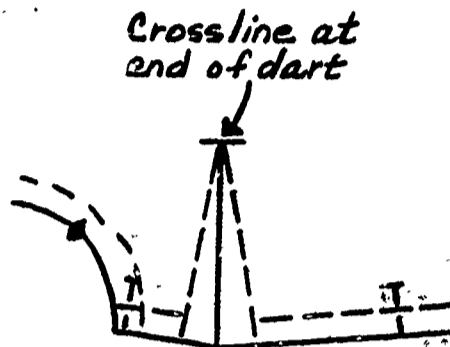

31

ans.

- tracing done with single straight lines
- crossline at end of dart
- ruler used

Trace the buttonhole markings as shown in the diagram below. Be sure to mark the crossline at the end of the buttonhole as indicated on the pattern.

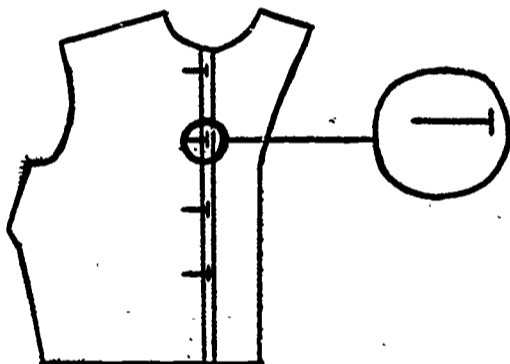

32

ans.

- buttonholes marked with crosslines at the end

Place the carbon paper in position and trace the other markings that need to be transferred to the fabric.

Dots are traced with a line through the middle of the dot as illustrated below. Use a ruler for all straight lines.

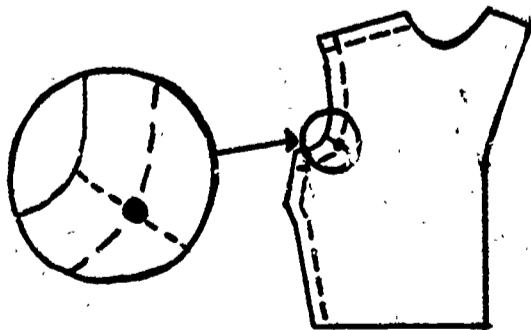

33

ans.

- Markings at
 - center front line
 - facing fold line
 - neckline curve
 - armhole curve
 - dots on armhole curve

- waxy sides against wrong sides of fabric

Trace the necessary markings on the blouse back and sleeves.

34

Place a check by the pattern markings you transferred to the fabric.

35

Back pattern
____ neckline curve

Sleeve
____ seam line between notches

____ armhole curve

____ dots on sleeve

____ shoulder darts

____ fold line for hem

____ dot on armhole curve

To the teacher:
Check all pattern pieces to see that all necessary points have been marked.

If you omitted any of these, trace them now.



"Blouse Construction"

The first series of frames (8-22) from the "Darts" section of the "Blouse Construction" part of the program illustrates the procedure used:

1. to teach a technique in clothing construction by use of both written and performance frames (8-11, 16-18, 20, 22)
2. to help students evaluate their work (12-15, 19, 21).

Use one of the blouse fronts.

8

ans.

With the right sides of the fabric together, fold the fabric along the fold line. Hold the fabric so the wide end of the dart is in your left hand.

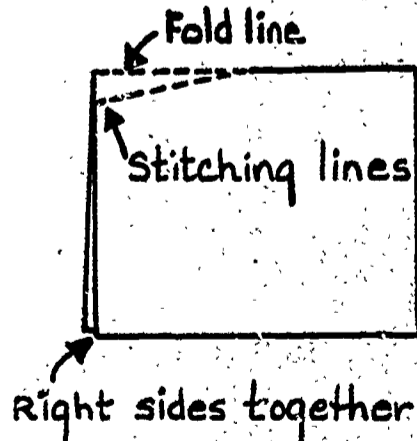
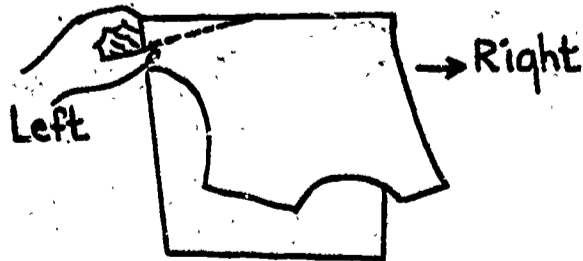

- 9
1. Stick the first pin through the folded fabric on the stitching line at the wide end.
 2. Check to see that the pin comes out on the stitching line on the opposite side. If the pin does not come out on the stitching line, refold and pin again.
 3. Insert the pins so that the pin points are toward the wide end of the dart.
 4. Finish pinning the dart with the last pin at the crossline.

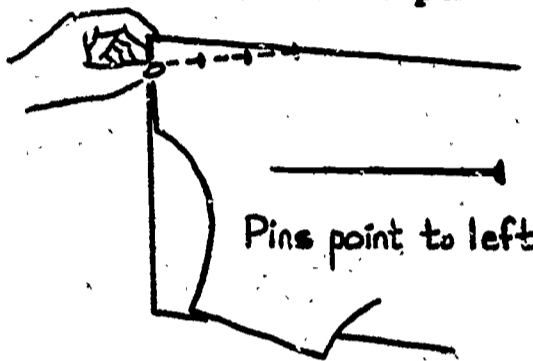

ans.

Stitching lines should be matched. If not, refold and pin again following directions on frame 9.

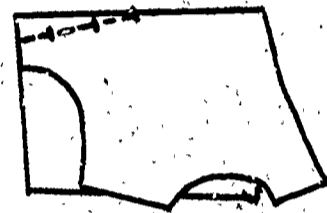

10

In which of the diagrams are the pins placed correctly for pinbasting a dart? _____

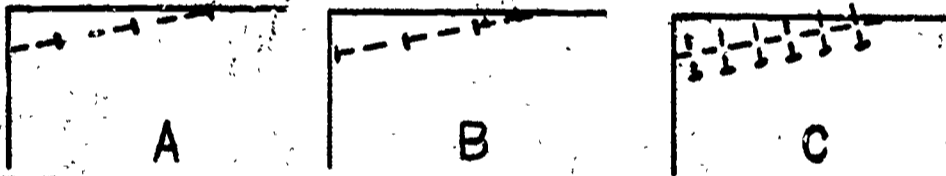

ans.

A

11

Pin the dart in the other blouse front.



To the teacher:
Check that darts are pinned with stitching lines matched.

12

The "key" to a good dart is the stitching at the narrow end.

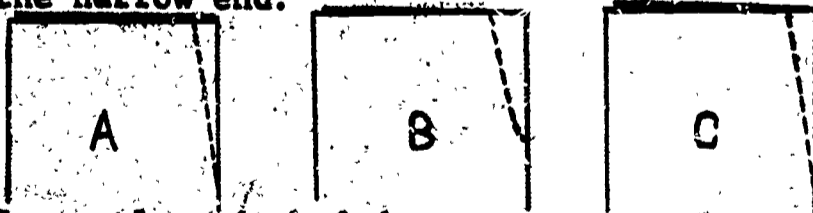

Correctly stitched darts are tapered to a point as illustrated in A. Which diagram (B or C) illustrates a correctly stitched dart? Why is the other dart incorrectly stitched? ** _____

ans.

C

end was not tapered to a point

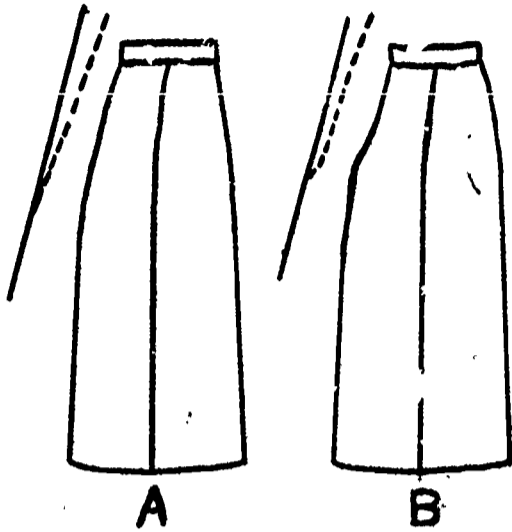

13

ans.

When a dart is correctly tapered to a point at the narrow end, the garment fits smoothly. An incorrectly stitched dart forms a pucker at the end of the dart.

A

A garment with correctly stitched darts is shown in diagram _____.

14

ans.

Correctly stitched darts end exactly at the marked crossline.

A

In which diagram(s) has(have) the dart(s) been correctly stitched? (A/B/C) _____.

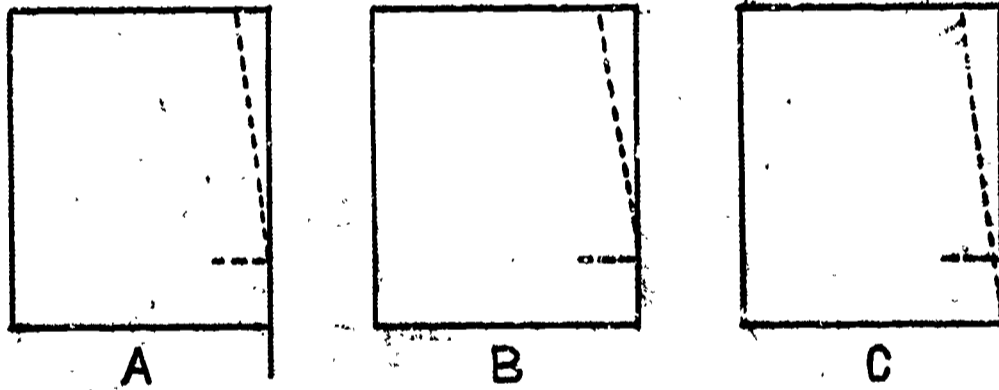

15

ans.

Refer to Panel H, Figure I, and examine the darts.

A

Which sample(s) illustrate(s) correctly stitched darts?

_____ A _____ B _____ C.

In the following steps you will stitch a dart.

Place the wide end of the dart under the presser foot and lower the needle into the stitching line at the cut edge of the fabric as illustrated.

1. Lower the presser foot.
2. Remove the first pin.
3. Stitch exactly on the marked line to the point of the next pin and stop with the needle in the fabric. Go on to the next frame.

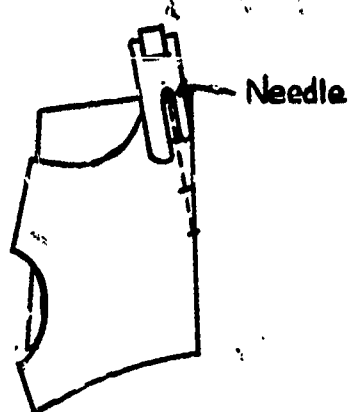

16

ans.

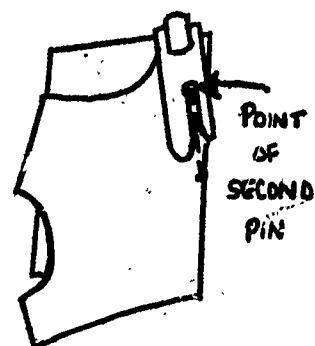

1. Remove the second pin and stitch to the point of the third. Again leave the needle in the fabric when you stop.
2. Remove the pin. Do the same for all pins, but stop about 4 stitches from the point.
3. Use the hand wheel to make the last stitches, tapering off to nothing at the point which you marked by a crossline. Leave three inches of thread on the end of the dart as you remove the fabric from under the presser foot.

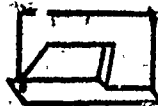

17

ans.

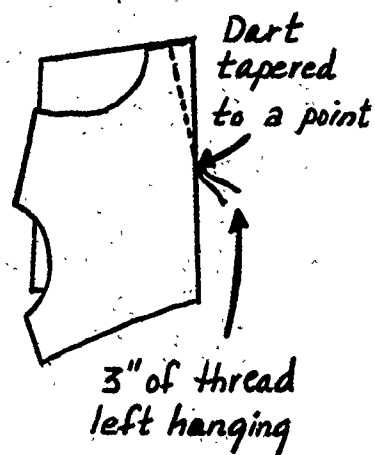

To secure the threads at the point of the dart tie a knot at the point of the dart. Trim the threads to 1/2".

18

ans.

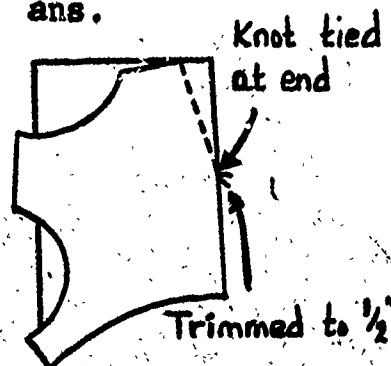

19
Compare the dart you stitched with the samples in Panel H, Figure 1.

Does the dart you stitched taper to nothing at the narrow end as dart A in Panel H, Figure 1?

_____ yes _____ no



20
Let's review!

Which illustration indicates the point at which stitching of a dart should begin? _____

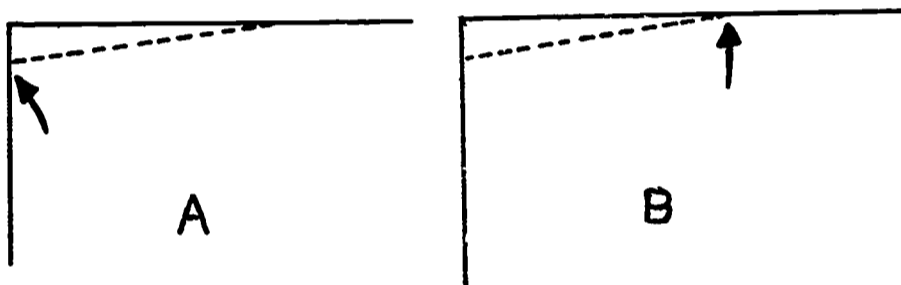

21
Which of the darts in Panel H, Figure II is stitched and secured correctly?

_____ A _____ B _____ C

22
Stitch the dart in the other blouse front.



ans.
A

ans.
A
Dart was stitched on the marked line, tapering off to nothing, and threads secured by tying a knot.

To the teacher:
Check that dart
-is stitched on marked line
-tapers to a point
-ends at the crossline
-threads are secured with a knot.

The second series of frames from the "Attaching Facings" section of "Blouse Construction" contains:

1. an inductive teaching sequence (29-36)
2. a deductive teaching sequence (39-40)
3. the use of a sample to teach a technique (46-51)
4. references to panels (38-40, 42-44, 52)
5. a hand frame (51)
6. both written and performance frames
7. symbols indicating to the student that on those frames machine stitching is required (46, 49, 51, 53).

21

Clipping is not the same as trimming.

ans.

Clipping is cutting into the seam allowance at right angles (\perp) to the seam line. The diagram below illustrates a seam allowance which has been _____.

clipped

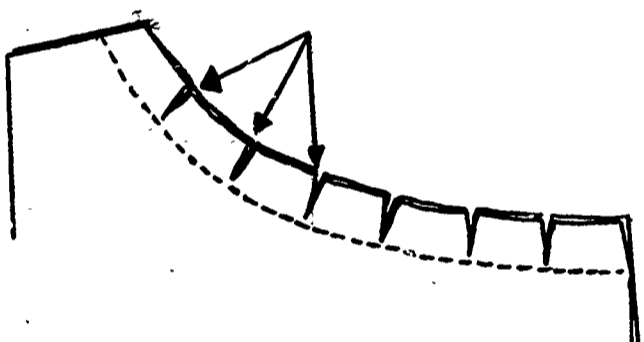

22

Diagram A shows a seam which has been (trimmed/ clipped) _____.

ans.

trimmed

Diagram B shows a seam which has been (trimmed/ clipped) _____.

clipped

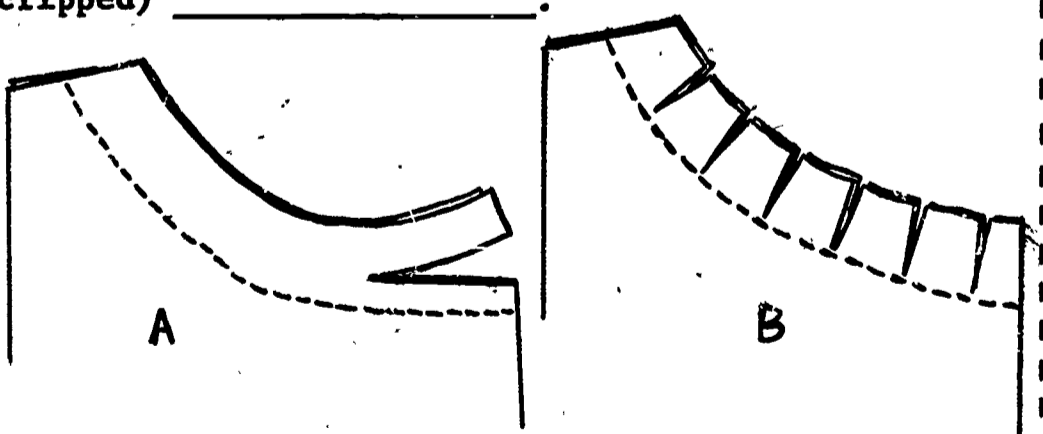

23

When clipping a seam allowance use only the points of the shears. Be sure the points of the shears do not go beyond the seam line.

Check the diagram in which the shears are being used correctly for clipping.

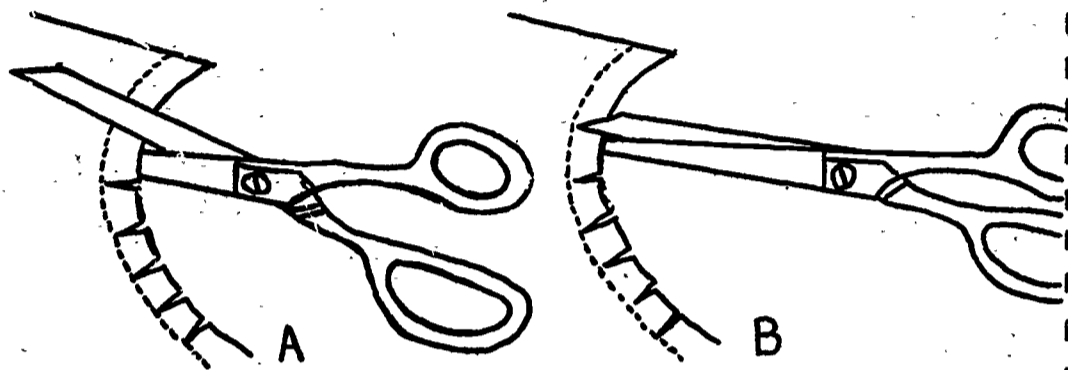

ans.

B

24

Only the points of shears are used for clipping seam allowances to prevent cutting through the stitching line. The diagram below illustrates a clipped seam.

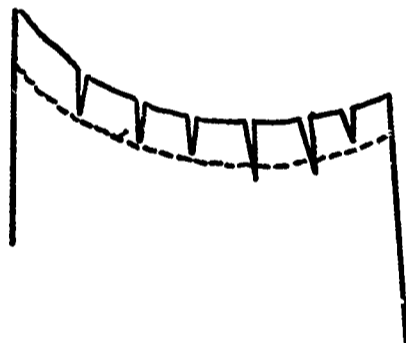

1. What was done wrong?
**
_____.
2. Why did this happen?
**
_____.

ans.

1. The clips go through the seam line
2. Because the points of the shears extended beyond the seam line.

25



This line is not straight, it is _____.

ans.

curved

26

The neck of a blouse is not a straight edge, it is a _____ edge.

ans.

curved

After stitching, the seam allowance on the neck edge of a blouse is on the (inside/outside) _____ of the curve. The inside space is (smaller/larger) _____ than the space outside the curve.

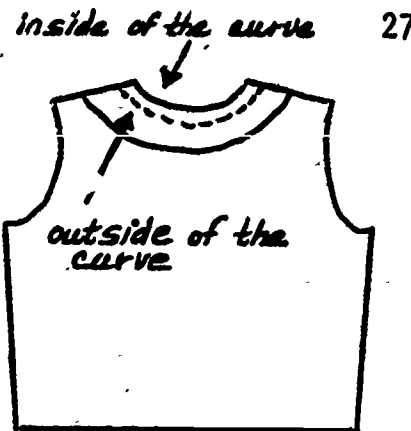

27

ans.

inside
smaller

When the facing is turned to the wrong side, the seam allowance must fit a (larger/smaller) _____ area.

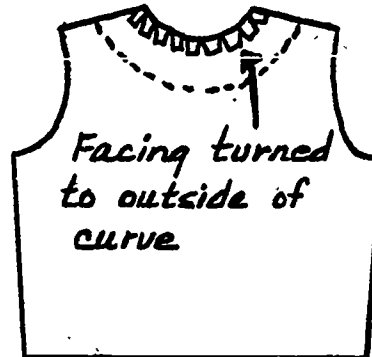

28

larger

To find out how to make the seam allowance spread to fit the larger area, try the following experiment.

29

1. Cut off the end of the frame.
2. Cut out the inside part of the curve along line A.
3. Save this paper blouse neckline and try each of the following frames to see what happens.

30

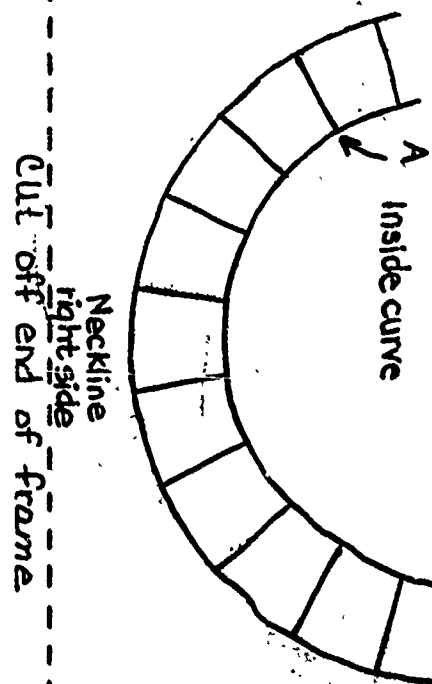

31 ans.
Try to fold the seam allowance to the wrong side of the paper blouse neckline along the heavy black line.

The seam allowance (did/did not) _____
fold back flat against the back side.

did not
It was impossible,
wasn't it!

32
Now clip the seam allowance on the black lines-- then fold the seam allowance back. Remember to use only the points of the shears and to be sure the points do not extend over the seam line.

33
Now, does the seam allowance lie flat against the wrong side of the paper neckline curve?

_____yes _____no

ans.
yes
yes

Did the seam allowance spread at the clipped places?

_____yes _____no

34
What did you do to the paper neckline edge to allow it to spread? ** _____
_____.

ans.
clipped it

35
Facing seam allowances which need to be clipped so they will spread and lie flat are those which are (curved/straight)
_____.

ans.
curved



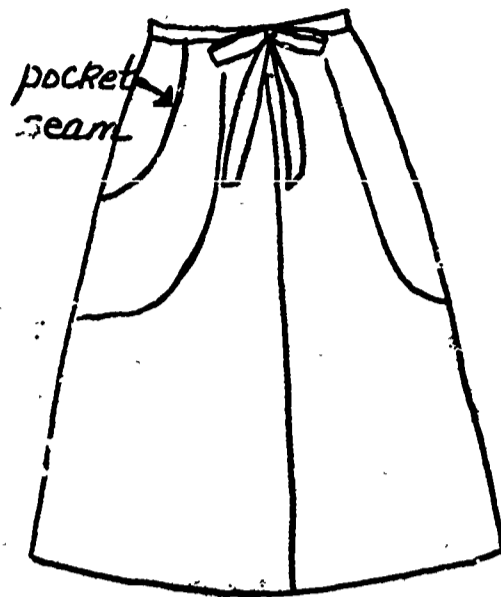

36

Suppose you were making a skirt with a pocket like the one shown here.

What needs to be done to the pocket seam allowance indicated? ** _____

Why? ** _____

ans.

it needs to be clipped

because it's curved

or

because the seam needs to spread

37

Seams are clipped to the line of stitching.

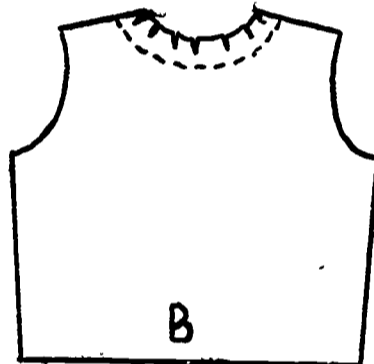
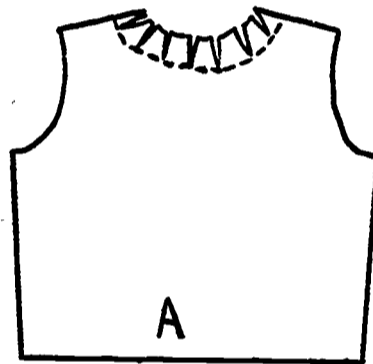

ans.

A

It is not clipped far enough.

1. Which clipping diagram is correct?

_____ A _____ B

2. What is wrong with the clipped seam allowance in the incorrect diagram?

** _____

38

Refer to Panel N, I and II.

Try to turn the facing in Figure I to the underside. Now try to turn the facing back in Figure II.

Which facing turned back the easiest and looked the smoothest?

_____ I _____ II

ans.

II

39

Refer to Panel N.

Clips are spaced approximately every 1/2" around a curved edge to allow the seam to spread.

Measure the space between two clips in both Figure II and Figure III.

approximately # _____", Figure II
approximately # _____", Figure III

ans.

1/4 - 1/2", II

1 - 1 1/2", III

40

Clips are spaced approximately every 1/2" around a curved edge to allow the seam to spread.

Refer to Panel N, Figure III. Why is the facing hard to turn back and the seam not smooth?

** _____.

ans.

There are not enough clips to allow the seam to spread

41

With the facing side up, clip the seam allowance around the curved neck edge of the blouse.

Remember to use the points of the shears.

It is all right to clip through the staystitching line.

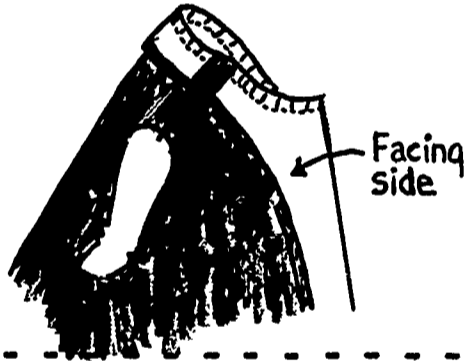

ans. Clipped through the staystitching line (not seamline) about every 1/2" or as much as needed to allow seam to spread



42

The diagram below illustrates a procedure called understitching.

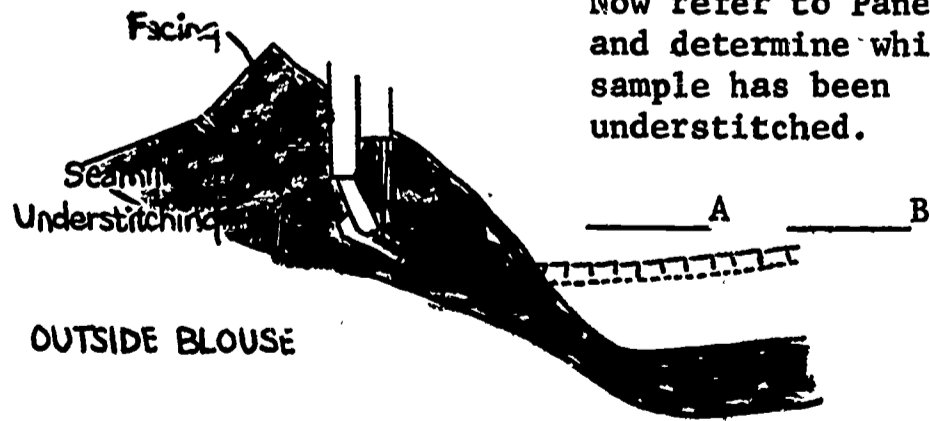

Now refer to Panel O and determine which sample has been understitched.

ans.

B

Understitching is a line of stitching which keeps the facing turned under.

43

ans.

understitching

The stitching in Panel C, Figure B is called _____ because it helps keep ** _____

the facing turned under

Refer to Panel O.

44

ans.

Facings should not show on the right side of the garment.

A

because it was not under-stitched.

In which sample does the facing show from the front of the blouse? _____ A _____ B
Why? ** _____

45

ans.

The purpose of understitching is ** _____

to keep the facing turned under

Remove the understitching sample A from the program kit.

46

Lay the sample on the machine near the presser foot so that you see the letters A, C, B.

Understitching

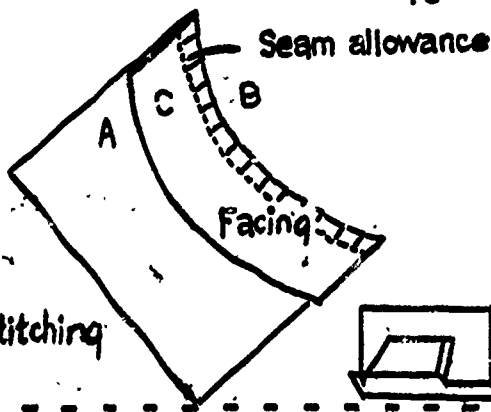

47

Use understitching sample A from the program kit.

With the sample still flat on the machine lift C (facing) at the arrow and turn it over the seam allowance to the right.

Seam lift

Facing - right side

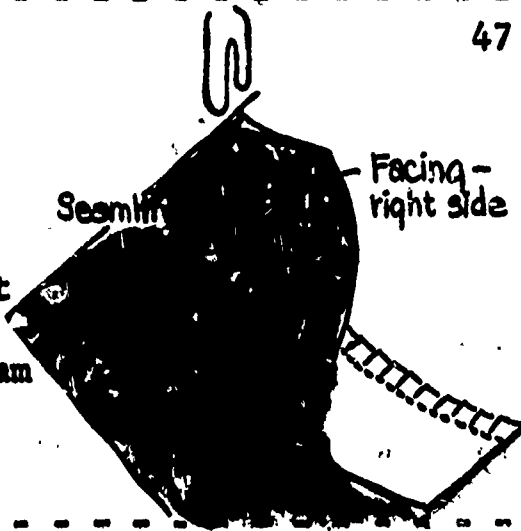

48

Use understitching sample. Look at the sample near the red line indicating the seam line.

What two parts of the sample are on the right side of the seam line?

garment seam allowance facing

ans.

garment

seam allowance

facing

49

Use the understitching sample.

In understitching, the seam allowance and the facing are stitched together.

Place the sample under the presser foot with the inside of the long toe against the seam line (red line). Your understitching will be on the blue line.

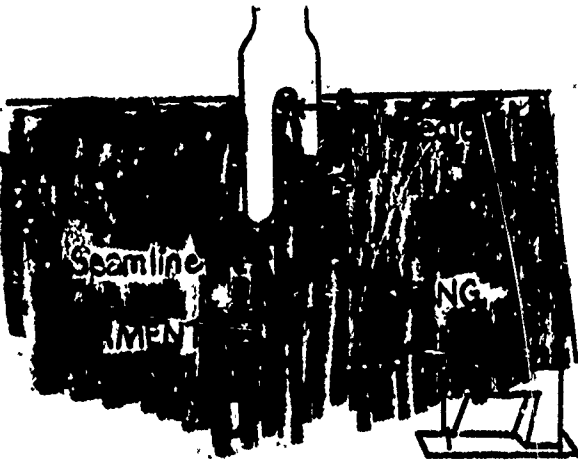

50

Read the entire frame before beginning to understitch.

As you understitch the facing, place your hands in the position shown and pull the facing gently to the right to keep the seam flattened.

Understitch by placing the inside edge of the long toe of the presser foot against the seam line.

Stop and straighten out fabric whenever necessary.

Now understitch.

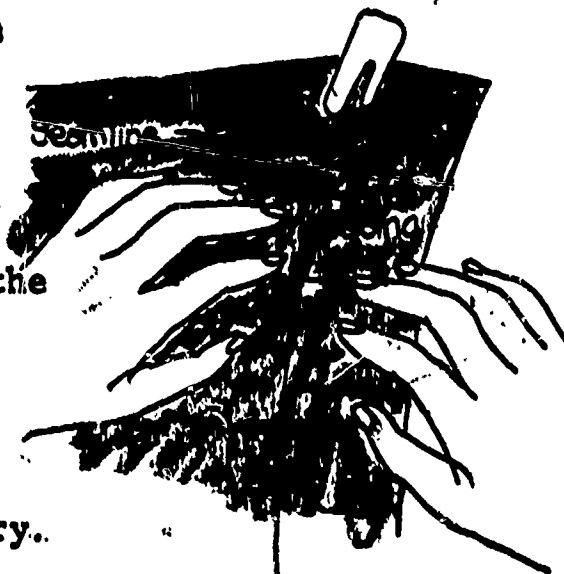

51

Use understitching Sample B from the program kit to understitch another facing.

To the teacher:
Check that sample is understitched correctly.



52

Refer to the understitching on the facing on Side 1, Panel I (Blouse).

ans.

When you understitch on the blouse it will be difficult to go completely into the corners.

b. 1" from each corner

In Panel I the understitching started and ended about

- a. 1/4" from each corner
- b. 1" from each corner
- c. 3" from each corner

53

Understitch the neck facing of your blouse in the same way that you understitched the sample. Refer to the sample if necessary.

Stop and check occasionally to see that the seam allowance is still under the facing.

DO NOT trim threads.

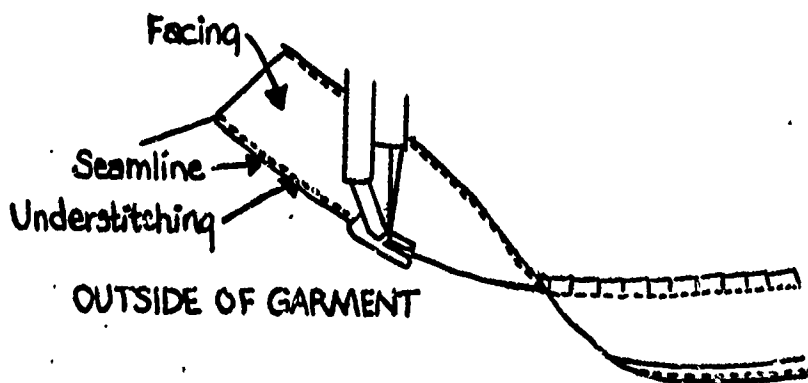

APPENDIX C

**Descriptive List of Panels and Exhibits
Accompanying Sewing Step-by-Step**

DESCRIPTIVE LIST OF PANELS AND EXHIBITS
ACCOMPANYING SEWING STEP-BY-STEP

A total of 54 panels were developed for use with Sewing Step-by-Step. A brief description of the panels accompanying each section of the program is given below.

"The Sewing Machine"

- Panel 1 - Samples of stitching with satisfactory and unsatisfactory tension adjustment

"The Pattern"

- Panel 1 - A figure type chart
- Panel 2 - Teen and Miss bodice front pattern pieces of the same size
- Panel 3 - Teen 14, Junior 13, and Miss 14 bodice front pattern pieces stapled at the shoulder line
- Panel 4 - Chart of Teens', Juniors', and Misses' body measurements and pattern sizes
- Panel 5 - Body measurements with the corresponding pattern sizes for each of five figure types
- Panel 6 - Pattern catalog
- Panel 7 - Set of two labeled pattern envelopes
- Panel 8 - Fabric squares with selvage and raw edges
- Panel 9 - Burlap fabric square with fabric terms lengthwise, crosswise, and selvage labeled
- Panel 10 - Fabric square with three corners labeled "A", "B", "C"
- Panel 11 - Fabric squares with torn and cut edges
- Panel 12 - A fabric sample 16" x 11" with notches cut at one-inch intervals along one edge
- Panel 13 - Fabric samples with cut and torn edges
- Panel 14 - Fabric samples with cut and torn edges
- Panel 15 - Fabric samples illustrating steps in procedure for straightening cut edges of fabric
- Panel 16 - Tissue paper illustrations of off-grain and on-grain fabric
- Panel 17 - An off-grain fabric sample
- Panel 18 - An off-grain fabric sample stapled to a cardboard rectangle of the same size
- Panel 19 - A half-size bodice front pattern piece with various markings numbered
- Panel 19a - A half-size bodice front pattern piece with various markings numbered
- Panel 20 - A size 12 blouse front pattern piece
- Panel 21 - A half-size bodice back pattern piece with the grain line arrow numbered

- Panel 22 - A half-size skirt pattern and samples which had been cut out on-the-fold of the fabric and on a single thickness
- Panel 23 - A half-size skirt pattern with dart markings, dots, and notches numbered
- Panel 24 - A half-size bodice front with various positions numbered
- Panel 25 - Two guide sheets with the cutting layouts numbered
- Panel 26 - Two fabric samples--one with a fold turned up even in width and one with an uneven fold
- Panel 27 - Two pattern pieces pinned to fabric--one on-grain and one off-grain
- Panel 28 - Two pattern pieces pinned to folded fabric--one pinned correctly and one with the fold line of the pattern piece 1/4" from the fold of the fabric
- Panel 29 - A neck facing pinned to folded fabric and to a single thickness of fabric
- Panel 30 - Bodice front and sleeve pattern pieces with various markings numbered
- Panel 31 - Two brown paper bodice fronts with fold lines and center front lines labeled
- Panel 32 - Bodice front and sleeve pattern pieces with various pattern markings numbered
- Panel 33A- Three samples of neckline facings marked with different colors of carbon paper.
- 33B- Two fabric samples with poor choices of carbon paper
- Panel 34A- One fabric sample with three choices of carbon paper
- 34B- Two fabric samples--one with markings on right side of fabric and one with markings on wrong side of fabric
- Panel 35 - Three pattern pieces pinned to fabric with carbon paper inserted correctly and incorrectly

"Bodice Construction"

- Panel A - Bodice front with neckline labeled "off-grain" and side seam labeled "on-grain"
- Panel B - Bodice front with arrows indicating different directions, one correct and one incorrect, to staystitch at side seams
- Panel C - Bodice front with round neckline cut on fold
- Panel D - Bodice front with square neckline cut on fold
- Panel E - Bodice front and extended facing with round neckline
- Panel F - Bodice front with staystitched neckline and arrows indicating direction and beginning and ending points for staystitching

- Panel G - Two fabric samples--one bridgestitched and one not
- Panel H - Six sample darts with two correctly stitched and four incorrectly stitched
- Panel I - Blouse with side 1 completed and correctly done and side 2 either incomplete or incorrectly done
- Panel J - Two examples of seams--one stitched with right sides together and one with one right and one wrong side together
- Panel K - A bodice front and back of construction paper
- Panel L - A bodice front stitched to the back at the shoulder seams--seam lines at the neckline matched on one side but not on the other side
- Panel M - Two collars--one with the seam allowance trimmed and one in which no trimming was done
- Panel N - Three samples of faced neckline curves--one neckline seam allowance not clipped, one clipped at 1/2" intervals, and one clipped at 1"- 1 1/2" intervals
- Panel O - Two faced neckline curves--one understitched and one not understitched
- Panel P - A blouse with a sleeve inserted except for about 3" around the cap of the sleeve--no ease distributed as the sleeve was inserted
- Panel Q - Three samples of hems of different widths but with 1/4" being the width of the first turn for all of them

**EXHIBITS ACCOMPANYING
SEWING STEP-BY-STEP**

- Exhibit 1 - A blouse pattern and 2½ yds. of fabric
- Exhibit 2 - One pair of dull shears, one pair of sharp shears, and muslin squares
- Exhibit 3 - A pair of shears and muslin squares marked with lines 1" long and 3"-4" long
- Exhibit 4 - A package of dressmaker's carbon paper
- Exhibit 5 - A package of dressmaker's carbon paper, a tracing wheel and muslin squares
- Exhibit 6 - A pressing ham with a dart sample pinned to it and a piece of cardboard with a plain seam pinned to it

APPENDIX D

Evaluation Devices Used in the Study

One-Hour Performance Test

Three-Hour Performance Test

Recall Test

Application Test

Blouse Rating Scale

Instructions to the Judges

**Sewing Experience
Questionnaire**

Name _____

ONE-HOUR PERFORMANCE TEST*

"The Sewing Machine" Test Student Instructions

Read the directions carefully. Your score will be influenced by how you follow the directions. Do each step as accurately and as rapidly as possible. If you have to wait for the teacher, study the next steps. At each "STOP" sign, raise your hand to call the teacher. She will score what you have done thus far.

PART I BOBBIN

1. Fill an empty bobbin about 1/3 full. Do not cut the threads. Do not remove the bobbin from the bobbin winder.

STOP - Raise your hand.

PART II THREADING THE MACHINE

1. Thread the machine, both upper and lower parts. Use a different color of thread on the upper part than you use on the bobbin.
2. Bring the bobbin thread up through the hole in the needle plate.
3. Check to see that the machine is ready to put the fabric in place and stitch.

STOP - Raise your hand.

PART III TENSION, STITCH-LENGTH REGULATOR AND STITCHING

1. Set the stitch-length regulator to sew 12-15 stitches per inch.
2. On the fabric provided, check the machine to see if the tension is correct. Continue to adjust the tension regulator and to check the machine until the tension is correct.

STOP - Raise your hand. The teacher will ask you to make a row of stitching 5/8 inch from the edge on another piece of fabric so she can check the way you stitch.

*This test reprinted from Sewing Step-by-Step by Johnson, Clawson, and Shoffner by permission of Ginn and Company. Copyrighted 1967.

PART IV REPLACING THE NEEDLE

1. Remove the needle. Place it on the sewing machine.
2. Pick it up and replace the needle.

STOP - Raise your hand.

"The Pattern" Test Student Instructions

PART V PATTERN LAYOUT

You will be given a blouse pattern and some fabric. Select the correct cutting layout for the pattern you received and for View 1. Place a pencil check mark by the layout you selected. Pin the blouse pattern pieces to the fabric.

PART VI SELECTING PATTERNS

Use the pattern book and select the size and figure type you would recommend for girls with the following measurements:

- | | | |
|-----------------------------|-------|-------------|
| 1. Bust - 33 1/4" | _____ | Size |
| Back Waist Length - 15" | _____ | Figure Type |
| 2. Bust - 32" | _____ | Size |
| Back Waist Length - 16 1/4" | _____ | Figure Type |

MATERIALS ACCOMPANYING ONE-HOUR PERFORMANCE TEST

Students were given the following materials for use in the sewing machine part of the one-hour performance test:

1. Two pieces of fabric, 6" square
2. Two spools of thread, each a different color
3. An empty bobbin

Materials provided for the pattern section of the test were as follows:

1. 1 2/3 yards fabric
2. A sleeveless blouse pattern with faced armhole and neckline
3. Straight pins
4. Tape measure
5. Pattern book

SCHOOL _____

NAME _____

DATE _____

ONE-HOUR PERFORMANCE TEST
TEACHER'S CHECK SHEET

Check each student's work at each "STOP" sign. (Note: The statements indicate the correct performance.) Place an "0" in the blank preceding each statement if the student performs incorrectly.

I THREADING THE BOBBIN

- _____ 1. spool of thread on bobbin spool pin
- _____ 2. thread guide is used
- _____ 3. bobbin is pushed onto the spindle
- _____ 4. stop-motion screw loosened

II THREADING THE MACHINE

- _____ 5. stop-motion screw tightened
- _____ 6. first thread guide threaded

tension regulator

- _____ 7. thread between discs
- _____ 8. thread in wire spring
- _____ 9. thread in thread guides on or near tension
- _____ 10. tension regulator threaded before thread take-up
- _____ 11. thread take-up threaded

needle

- _____ 12. thread guides threaded
- _____ 13. threaded from side of last thread guide

threads

- _____ 14. bobbin thread brought to surface
- _____ 15. threads pulled under presser foot and toward back

bobbin

- _____ 16. bobbin turns in correct direction
- _____ 17. thread placed in slot and under spring
- _____ 18. thread take-up and needle at highest points

III TENSION, STITCH-LENGTH REGULATOR,
AND STITCHING

- _____ 19. needle placed in fabric before presser foot is lowered
- _____ 20. hand wheel used for first few stitches
- _____ 21. bulk of fabric to left of needle
- _____ 22. stitching is 5/8" from edge
- _____ 23. left hand placed on fabric behind presser foot and right hand in front of presser foot
- _____ 24. hand wheel used to make last few stitches
- _____ 25. stops before stitching off edge of fabric
- _____ 26. thread take-up and needle left at highest points
- _____ 27. fabric pulled toward back
- _____ 28. leaves enough thread so needle will remain threaded
- _____ 29. stitching looks same on both sides of fabric
- _____ 30. stitch-length regulator set for 12-15 stitches per inch
- _____ 31. screw on stitch-length regulator tightened

IV REPLACING THE NEEDLE

- _____ 32. long groove on side of last thread guide
- _____ 33. needle screw tight

V PATTERN LAYOUT

- _____ 34. correct layout selected
- _____ 35. fabric folded as suggested on cutting layout
- _____ 36. fabric folded on-grain (selvages on top of each other)

pattern pieces placed as suggested on cutting layout

- _____ 37. blouse front
- _____ 38. back neck facing
- _____ 39. front neck facing
- _____ 40. armhole facing
- _____ 41. blouse back

pattern pieces pinned on grain (within 1/16")

- _____ 42. blouse back
- _____ 43. armhole facing
- _____ 44. back neck facing

pattern fold line on fold (within 1/16")

- _____ 45. blouse front
- _____ 46. front neck facing
- _____ 47. pins on each end of grain line on blouse back and armhole facing

pins at corners

- _____ 48. blouse front
- _____ 49. blouse back
- _____ 50. all but two pins perpendicular to cutting line on the blouse front, blouse back, and armhole facing
- _____ 51. all pins inside cutting line

VI PATTERN SELECTION

- _____ 52. (1) selected size 11
- _____ 53. (1) selected Junior Petite
- _____ 54. (2) selected size 12
- _____ 55. (2) selected Misses

THREE-HOUR PERFORMANCE TEST

The construction processes you will be asked to do in this test are similar to things you might be doing if you sew at home. You will not have a garment by the time you complete the steps below--in fact, the end product is going to look rather strange.

When you read some of the directions below, you may think you do not know how to follow them because on your blouse you did not do some of the steps described. Don't let this discourage you. Go ahead and do whatever you think might be right--try to figure out a way to do it. If you can't, do not worry about it. Go on to the next item.

Read the directions carefully. Your score will be influenced by how well you follow the directions. Do each step as accurately and as rapidly as possible. If you have to wait for the teacher, study the next steps. At each black dot, ●, raise your hand to call the teacher. She will want to watch you during that step.

- A. The teacher will ask you some questions about parts of the sewing machine.
- B. Refer to the guide sheet in the pattern envelope (4601) and fold the fabric as shown in:
 - 1. the third (3rd) cutting layout under View 1. ●
 - 2. the third (3rd) cutting layout under View 2. ●
- C. You have been given a skirt pattern and some fabric.
 - 1. Select the cutting layout diagram for View 1 that is correct for the pattern and the fabric you were given. Place a pencil check mark by the cutting layout you chose.
 - 2. Following the cutting layout, pin the skirt front and waistband pattern pieces to the fabric. When you are ready to pin the skirt back pattern piece, ● raise your hand.
- D. You have been given a piece of fabric with a pattern piece pinned to it.
 - 1. ● Cut out the pattern piece. Use the cutting line at the neckline for View 3 and 4.
 - 2. Use a tracing wheel and carbon paper to trace all necessary markings.

E. Use materials labeled C and the blouse front you just cut out and marked for the following procedures:

1. Staystitch necessary edges of the blouse front.
2. Stitch the underarm dart on the right side of the blouse front. Press the dart.
3. Pinbaste, stitch and press the shoulder seams.
4. a. Select the armhole facing for the left armhole. Bridgestitch and cleanfinish the outer edge of the facing. Pinbaste and stitch it to the left armhole.
b. Call the teacher and then do all that is necessary to complete the armhole facing. Press the facing to the wrong side.
5. Stitch the right side seam of the blouse.
6. Choose the sleeve for the right armhole and pinbaste it into the armhole so it is ready to stitch. Do not stitch it.
7. Refer to the blouse guide sheet you were given. Follow the directions which have been circled in red and make a collar. Raise your hand when you are ready to
 - a) press
 - b) understitch.
8. Using the pattern for the blouse front, cut a facing 2 1/2" wide for the front neckline from the fabric you were given.

MATERIALS ACCOMPANYING THREE-HOUR PERFORMANCE TEST

A packet of materials was prepared for each student for the three-hour performance test. These packets included the following items:

1. 1 1/2 yds. fabric
2. Simplicity skirt pattern #4601
3. A piece of fabric with a blouse front pattern piece pinned to it
4. A blouse back which had been cut out and marked
5. Two armhole facings
6. Two sleeves, which had the ease threads stitched, and the underarm seam stitched and pressed open
7. A collar, collar facing, and a guide sheet with the directions for making the collar circled in red
8. A piece of fabric 10" x 16"

OBSERVER
THREE-HOUR PERFORMANCE TEST

Place a "1" in the space when the student responded or performed correctly and an "0" when she responded or performed incorrectly.

- A. 1. Show student a machine which is different from the one on which she worked and ask student to locate the following parts:

- 1. thread take-up
- 2. spool pin
- 3. three thread guides
- 4. tension regulator
- 5. wire spring on tension regulator
- 6. thread guide on tension regulator
- 7. bobbin winder
- 8. stop-motion screw

2. Ask student to thread the upper parts of a machine which is different from the one on which she worked.

9. first thread guide threaded

tension regulator

- 10. thread between discs
- 11. thread in wire spring
- 12. thread in thread guides on or near tension
- 13. tension regulator threaded before thread take-up
- 14. thread take-up threaded

needle

- 15. thread guides threaded
- 16. threaded from side of last thread guide

- B. Folding Fabric

- 17. folded fabric lengthwise
- 18. folded fabric crosswise

- C. Pattern Layout

- 19. fabric straight with the grain
- 20. fold in fabric even in width

- 21. correct cutting layout selected
- 22. fabric folded as cutting layout suggested

Pattern pieces placed exactly as recommended on cutting layout

- 23. skirt back
- 24. skirt front
- 25. waistband

Pattern pieces placed on grain (within 1/16" -- measure from nearest selvage edge)

- 26. skirt back
- 27. waist band

Pattern fold line placed on fold (within 1/16")

- 28. skirt front
- 29. * measures from grain line to selvage
- 30. * pins grain line first
- 31. * pins at corners before filling in areas between corners

D. Cutting and Marking

- 32. * places hand on pattern while cutting
- 33. notches cut outward
- 34. * tracing paper placed to mark right and left halves at the same time

All necessary positions marked on bodice front

- 35. underarm dart
- 36. waistline dart
- 37. neckline seam line
- 38. armhole seam line
- 39. dot on armhole seam line
- 40. markings on wrong side of fabric
- 41. markings traced with single strokes
- 42. dart lines are marked straight, even if there is more than one line
- 43. marked across end of darts
- 44. markings show on both right and left halves of garment

* Observer must be present to watch this procedure.
Other items can be checked after the test is completed.

E. Construction

Staystitching

- _____ 45. * staystitches neckline in correct direction
- _____ 46. neckline staystitched
- _____ 47. 1/8" or less from the seam line toward the cut edge (at least 2/3 of distance)

Darts

- _____ 48. stitching on tracing wheel lines on both sides of dart (within 1/16")
- _____ 49. tapered evenly with no "pucker"
- _____ 50. dart ends at cross line or end of marking
- _____ 51. stitching secured with a knot at narrow end
- _____ 52. * uses curved surface for pressing
- _____ 53. * uses point of the iron on line of stitching
- _____ 54. pressed toward hem

Shoulder seam (right)

- _____ 55. seams matched at the seam line at the neckline
- _____ 56. notches matched (within 1/16" at the point of the notch)
- _____ 57. * pins at right angles to seam line
- _____ 58. * pinbastes with the fuller side up
- _____ 59. * stitches with the fuller side up
- _____ 60. 5/8" seam (within 1/16")
- _____ 61. seam pressed open

Facings

- _____ 62. outer edge of facing bridgestitched
- _____ 63. bridgestitching 1/4" from edge (at least 2/3 of the way)
- _____ 64. outer edge of facing cleanfinished
- _____ 65. stitched about 1/8" from fold (at least 2/3 of the way)
- _____ 66. correct facing used
- _____ 67. stitched with right sides together
- _____ 68. seam trimmed to approximately 1/4"
- _____ 69. seam clipped to 1/16" of line of stitching
- _____ 70. * uses points of shears for clipping
- _____ 71. clips at least at intervals of 2"
- _____ 72. understitched on the facing
- _____ 73. seam understitched to facing

Seams

____ 74. 5/8" wide (within 1/16")

Sleeves

- ____ 75. correct sleeve selected for the armhole
____ 76. right sides together
____ 77. single notches matched (to 1/16")
____ 78. double notches matched (to 1/16")
____ 79. dots on back of sleeve and armhole matched
____ 80. center of sleeve cap at shoulder seam (within 1-2 threads)
____ 81. ease evenly distributed so when stitched no puckers would result
____ 82. both lines of ease threads were pulled

Collar

- ____ 83. stitched un-notched edges
____ 84. seam trimmed
____ 85. corner trimmed (give credit for trimming even if it wasn't trimmed close enough)
____ 86. * presses seam toward collar facing
____ 87. understitched on the facing
____ 88. seam understitched to facing
____ 89. * stitches on right side of fabric

Facing

- ____ 90. facing cut same shape as neckline
____ 91. facing cut off at shoulder line
____ 92. facing cut on-grain

RECALL TEST*

Your answers for this test are to be recorded on the IBM answer sheet. Find the number on the IBM answer sheet which is the same as the number of the question on the test. Select ONE response for each item and fill in the "response space" for the answer you select with a solid black pencil mark.

Be sure your mark does not go beyond the "response space" for the answer you have chosen. If you make a mistake and mark the wrong space, erase the mark completely before marking the correct space.

Example: 1. The capitol city of the United States is

- 1. New York
- 2. Washington, D. C.
- 3. Los Angeles

1. 1 = = = = ② ————— 3 = = = = 4 = = = = 5 = = = =

Number 2 is the correct answer so that "space" has been filled in.

1. Which number labels the presser-foot bar?

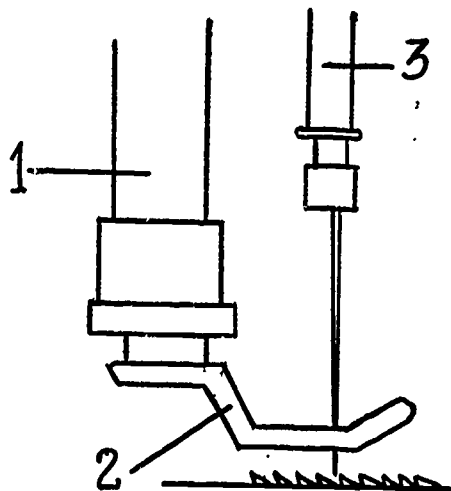

*This test reprinted from Sewing Step-by-Step by Johnson, Clawson, and Shoffner by permission of Ginn and Company. Copyrighted 1967.

2. Refer to diagram. Which one of the following statements is correct about the kinds of bobbin cases illustrated?

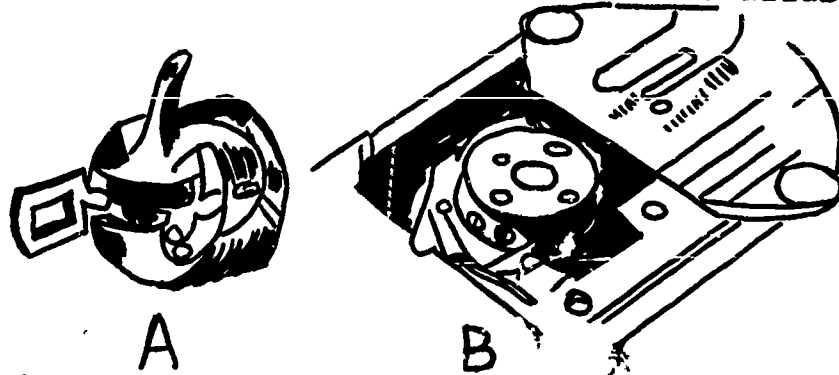

1. A is not taken out of the machine to place the bobbin in it, and B is removed
 2. B is not taken out of the machine to place the bobbin in it, and A is removed
 3. both are taken out of the machine
3. The stop-motion screw is located on the
1. foot or knee control
 2. hand wheel
 3. needle bar
4. Which part of the sewing machine is moved when it is necessary to reverse the direction of stitching?
1. presser-foot lifter
 2. hand wheel
 3. stitch-length regulator
5. Sue is making a skirt of medium weight cotton fabric. Between which numbers should she set the stitch-length regulator for stitching the seams?
1. 6-8
 2. 9-11
 3. 12-15
6. The setting of the stitch-length regulator in the diagram shows that the machine will make stitches that are

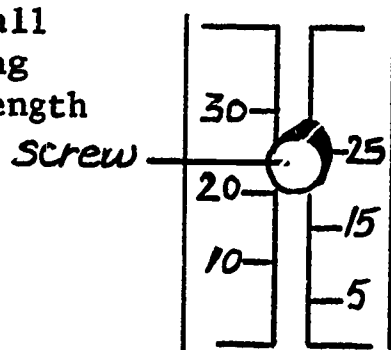

Read each purpose listed in column 1. Select from the list of sewing machine parts the one which performs this work. Fill in its number on the answer sheet. The parts in column 2 may be used more than once or they may not be used at all.

Column 1 - Purposes

Column 2 - Parts

7. holds fabric in place
8. starts and stops the machine
9. keeps needle from moving
10. moves material along

1. feed dog
2. presser foot
3. hand wheel
4. stop-motion screw
5. thread take-up

Column 1 - Purposes

Column 2 - Parts

11. holds thread in place in various places on the machine head
12. controls tightness of thread
13. is moved to remove or insert the bobbin
14. pulls the thread to make a stitch

1. presser foot
2. slide plate
3. tension regulator
4. thread guide
5. thread take-up

On the answer sheet fill in the number of the sewing machine part from the diagram.

15. presser-foot lifter
16. tension regulator
17. thread guide
18. thread take-up

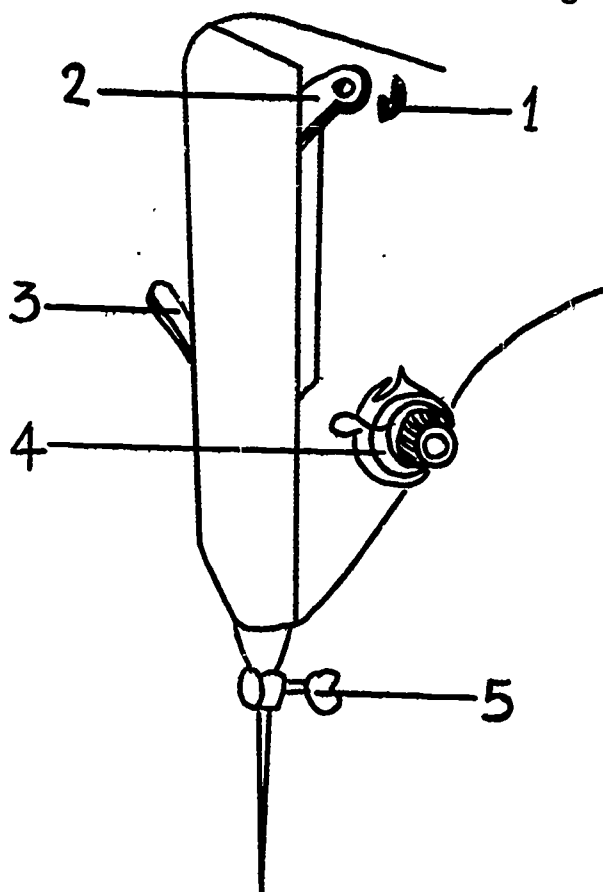

On the answer sheet fill in the number of the sewing machine part from the diagram.

19. feed dog

20. needle

21. presser foot

22. slide plate

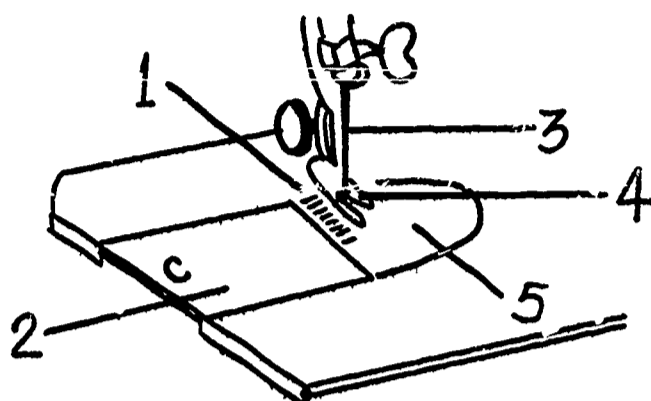

23. Susie wants to buy a blouse pattern. She should

1. buy the same size as her friend who is the same age she is
2. buy the same size she buys in a ready-made blouse
3. buy the size indicated by her body measurements

24. When taking a bust measurement, the tape measure should be placed

1. above the fullest part of the bust
2. over the fullest part of the bust
3. below the fullest part of the bust

For each of items 25-28 select the number from the diagram which corresponds to the terms.

25. grainline

26. facing fold line

27. dart lines

28. center front

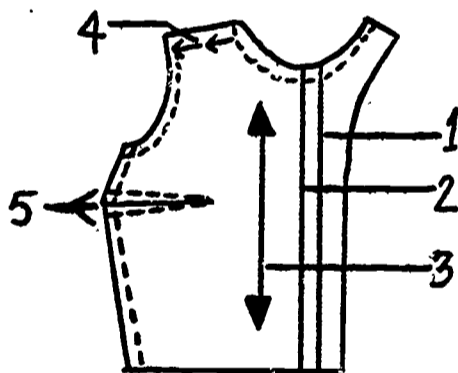

29. To determine whether or not a pattern piece is placed on the fabric straight with the grain, one should measure to see if the distance is the same from

1. both ends of the grainline arrow to the center front line
2. both ends of the grainline arrow to the selvage edge
3. the edges of the pattern piece to the selvage edge

30. Cutting layout diagrams do not show how pattern pieces are arranged

1. for steps in construction
2. on different widths of fabric
3. on the fabric for different sizes

31. Garments which are cut off grain will probably
 1. not hang correctly
 2. shrink when laundered
 3. show signs of wear sooner

32. During the process of pinning the pattern to the fabric, the pattern pieces should
 1. be placed, one at a time, on the fabric and pinned
 2. all be placed on the fabric before the final pinning
 3. be pinned and cut one section at a time

33. When pinning pattern pieces to the fabric, the first pins should be placed
 1. at the corners
 2. in the center
 3. on the grainline

34. When cutting out edges of a garment piece that are straight, one should use
 1. short strokes
 2. the points of shears
 3. long strokes

35. Which of the lines in the diagram should be followed when cutting out the garment unit?

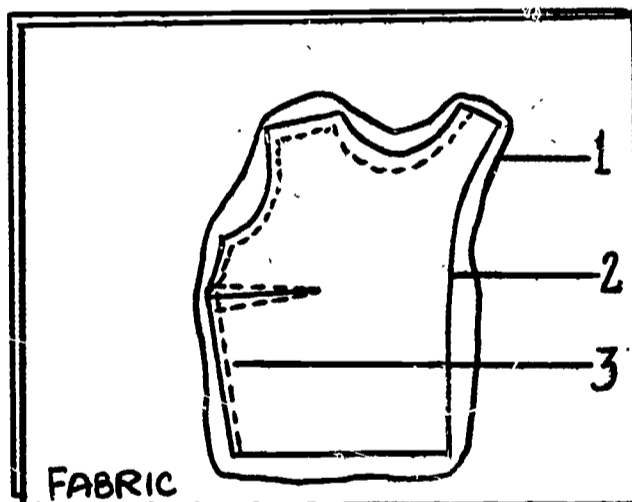

36. When Susie comes to a notch on the pattern, she should cut
 1. outward, away from the pattern
 2. in, toward the seam allowance
 3. straight across the notch

37. Which of the pattern markings shown on the diagram does not need to be marked on the fabric?

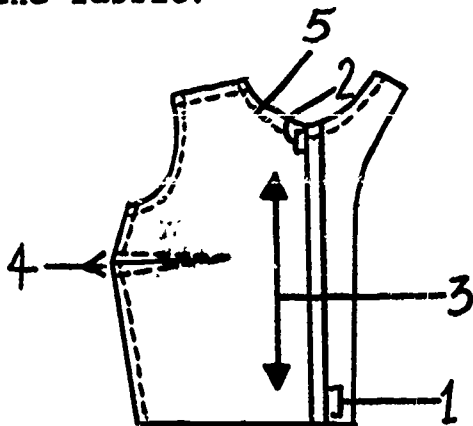

38. The color of the dressmakers' carbon paper selected for marking should
1. be several shades darker than the fabric to be marked
 2. match the fabric to be marked
 3. show on the wrong side of the fabric without showing on the right side
39. Markings made with a tracing wheel
1. should always be on the wrong side of the fabric
 2. should always be on the right side of the fabric
 3. are sometimes placed on the wrong side and sometimes on the right side
40. A mark from the tracing paper is left on the fabric from
1. the "waxy" side of the tracing paper
 2. the dull side of the tracing paper
 3. both sides of the tracing paper
41. Patterns should be selected according to
1. age and size
 2. figure type and age
 3. size and figure type
42. The figure types used by pattern companies are determined by
1. age
 2. proportions of body measurements
 3. height and weight

For each of items 43-45, select the number from the diagram which corresponds to the term.

43. selvage
44. lengthwise threads
45. crosswise threads

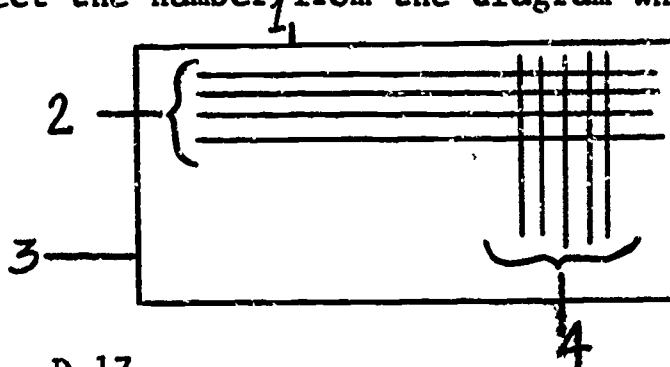

46. To determine whether or not a piece of fabric is on grain it should be folded
1. lengthwise
 2. crosswise
 3. on the bias
47. The test for determining whether or not the ends of the fabric are straight with a thread is to
1. see if one crosswise thread ravel from selvage to selvage without being stopped by other crosswise threads
 2. fold the fabric lengthwise to see if the raw edges match
 3. pull on the true bias every few inches
48. The test for determining whether or not a piece of fabric is on grain is to
1. pull a crosswise thread and cut across the fabric following the line left by the pulled thread
 2. fold the fabric, selvages together, and check to see if the ends match
 3. gently pull on the bias across the fabric
49. It is usually necessary to pull a crosswise thread and cut across the ends of the fabric when it has been
1. cut from the bolt
 2. torn from the bolt
50. The table which gives the fabric yardage required for various views, sizes and widths of fabric is found on the
1. front of the pattern envelope
 2. back of the pattern envelope
 3. guide sheet
51. Which of the following types of information is not found on the pattern envelope?
1. fabric suggestions for the pattern
 2. sewing notions required
 3. cutting layout
52. Susie wants to know what size pattern her sister bought for her. She can find this information on the
1. back of the pattern envelope
 2. guide sheet
 3. front of the pattern envelope
53. Pattern markings that help in putting pieces of a garment together correctly are
1. dots
 2. grainline arrows
 3. dart lines

54. When should staystitching be done?
1. as the first process on a garment piece
 2. just before the final pressing
 3. at any convenient point during the construction process
55. The length of machine stitches for staystitching and bridgestitching cotton fabric of medium weight should range between
1. 6-8
 2. 12-15
 3. 15-17
56. Where should staystitching be done?
1. $\frac{1}{4}$ " from the cut edge of the garment piece
 2. within $\frac{1}{8}$ " from the seam line toward the cut edge
 3. within $\frac{1}{4}$ " from the seam line toward the cut edge
57. How far from the cut edge of the garment unit should bridge-stitching be done?
1. $\frac{1}{4}$ "
 2. $\frac{1}{2}$ "
 3. $\frac{5}{8}$ "
58. The purpose of staystitching is to prevent
1. raveling while the garment is being made
 2. facings from showing on the right side of the garment
 3. stretching while the garment is being made
59. The purpose of a dart is to
1. fit flat fabrics to curves of the body
 2. prevent strain in certain areas of the garment
 3. provide ease
60. In the following diagram, which of the arrows points to the line on which the dart should be folded for pinbasting?

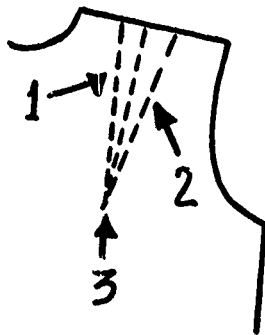

61. The purpose of bridgestitching is to
1. prevent the edges from stretching during construction
 2. prevent the edges from raveling
 3. form a line on which to turn an edge

62. The correct direction for pressing horizontal darts is
1. down, toward the hem
 2. up, toward the armhole
 3. in either direction
63. The general rule for pressing darts is to press them
1. immediately after each dart is stitched
 2. when the garment is completed
 3. before the dart is crossed by another line of stitching
64. How far from the cut edge are most plain seams stitched?
1. 3/8"
 2. 1/2"
 3. 5/8"
65. A plain seam is stitched with
1. right sides of the garment pieces together
 2. wrong sides of the garment pieces together
 3. the right side of one garment piece against the wrong side of the other garment piece
66. The purpose of trimming seam allowances is to
1. relieve the strain on the seam allowance
 2. allow the seam to spread and make a smooth curve
 3. eliminate bulk
67. Trimming a seam allowance means to cut
1. parallel to the seam line
 2. at right angles to the seam line
 3. V-shaped wedges in the seam allowance
68. Which of the seam allowances in a blouse is not trimmed?
1. the facing shoulder seam allowance
 2. the neckline seam allowance
 3. the side seam allowance
69. In which of these areas of a garment is there no ease?
1. shoulder seam
 2. underarm portion of sleeve
 3. side seam
70. When stitching a sleeve into the armhole, stitch with the presser foot on the
1. sleeve side
 2. garment side

71. The armhole curve of the bodice to which a sleeve is attached as compared to the sleeve cap is
1. fuller
 2. smaller
 3. the same size
72. Sue's teacher told her to ease the shoulder seam. This means Sue would
1. stitch two lines of ease threads on the shoulder seam allowance
 2. match the seam at the neckline and trim off the extra at the shoulder
 3. match notches and work in the extra fabric
73. An eased seam should be pinbasted and stitched with which side up?
1. the eased or fuller side
 2. the side that was not eased
 3. either side
74. The term ironing means
1. using the point of the iron and steam
 2. alternately lifting and lowering the iron
 3. moving the iron back and forth in long strokes
75. Which of the following areas of a garment should be pressed on a curved surface?
1. the bottom hem line
 2. an underarm dart
 3. the blouse side seam
76. Plain seams are usually pressed
1. to one side
 2. on a curved surface
 3. open using the point of the iron
77. Outer edges of facings on a medium weight cotton blouse should be
1. cleanfinished
 2. hemmed
 3. understitched
78. Extended facings are
1. separate units cut at the same time as the garment
 2. cut on the opposite grain as the outer section to be faced
 3. cut in one piece with the garment section

79. The purpose of a facing is to
1. finish raw edges of a garment
 2. prevent stretching of curved edges
 3. keep raw edges from raveling
80. A facing that is a separate piece and cut the same shape as the section to be faced is called a(n)
1. extended facing
 2. fitted facing
 3. bias facing
81. A neckline facing on a blouse is held in place by
1. tacking it to the shoulder seam allowance
 2. hemming it to the blouse all the way around
 3. cleanfinishing and pressing
82. The size of stitches used for easing or gathering threads as compared to those used for seams should be
1. the same
 2. shorter
 3. longer
83. When Sue does her staystitching, she should
1. tie the threads at the beginning and end of the lines of stitching
 2. trim the threads close to the seam but not secure them
 3. backstitch at the beginning and end of the lines of stitching
84. The purpose of cleanfinishing the outer edge of a facing is to
1. prevent raveling
 2. maintain the grain line
 3. prevent stretching
85. Seam allowances that need trimming should be trimmed to
1. $1/16''$
 2. $1/4''$
 3. $3/8''$
86. When stitching a straight hem, as on the bottom of a blouse, the line of stitching should be placed as indicated in diagram.

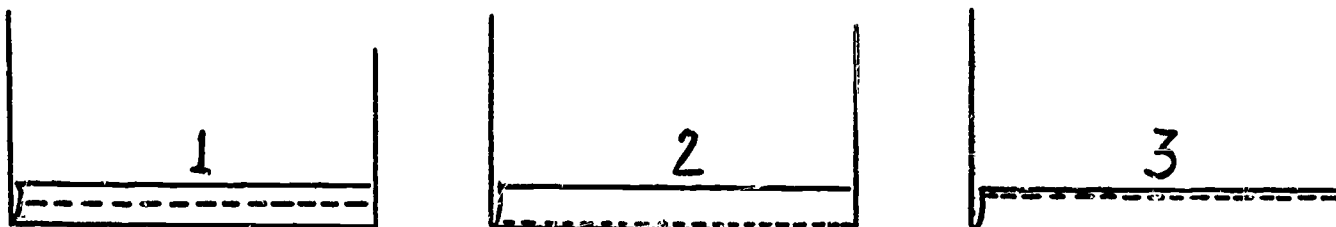

87. The purpose of understitching is to
1. form a line on which to turn under the hem
 2. help keep the facing to the underside
 3. keep the outside edges of facings from raveling
88. To finish the underarm part of the armhole seam, you were taught to
1. understitch the seam allowance
 2. trim the seam allowance to 1/4" between the notches
 3. clip the seam allowance between the notches

APPLICATION TEST*

Your answers for this test are to be recorded on the IBM answer sheet. Find the number on the IBM answer sheet which is the same as the number of the question on the test. Select ONE response for each item and fill in the "response space" for the answer you select with a solid black pencil mark.

Be sure your mark does not go beyond the "response space" for the answer you have chosen. If you make a mistake and mark the wrong space, erase the mark completely before marking the correct space.

Example: 1. The capitol city of the United States is

1. New York
 2. Washington, D. C.
 3. Los Angeles
1. 1 = = = = 2 = = = = 3 = = = = 4 = = = = 5 = = = =

Number 2 is the correct answer so that "space" has been filled in.

1. As Susie threads her mother's sewing machine, she cannot find one of the thread guides between the thread take-up and the needle that she used on the machine at school. What should she do?
 1. nothing because the number and position of thread guides vary on different machines
 2. continue to look because all machines have the same number of thread guides
 3. continue to look because all machines have thread guides in the same places
2. Sue broke the machine needle at home. She remembered that there was some rule about replacing machine needles. She put the needle in so the short groove was on the side of the last thread guide. Which of the following statements is true?
 1. she was wrong; the long groove should be on the side of the last thread guide
 2. she was right; the short groove should be on the side of the last thread guide
 3. she was right because the needle can be put in either way
3. Look at Exhibit A. Select the line of stitching in which the tension appears to be too tight. Fill in the number on the answer sheet of the stitching you chose.

*This test reprinted from Sewing Step-by-Step by Johnson, Clawson, and Shoffner by permission of Ginn and Company. Copyrighted 1967.

4. Look at Exhibit B. Select the line of stitching in which the upper tension appears to be too tight. Fill in the number on the answer sheet of the stitching you chose.
5. Sally made a line of stitching on a square of fabric. It looked like Exhibit C. Which statement below describes the stitching?
 1. the upper tension is too tight
 2. the upper tension is correct
 3. the upper tension is too loose
6. In which direction should Sally turn the knob on the tension regulator so the tension for Exhibit C will be correct?
 1. to a larger number
 2. to a smaller number
 3. leave it where it is
7. If Sally's guide sheet instructed her to stitch small stitches along a particular dotted line, the stitch-length regulator should be set like (choose one)

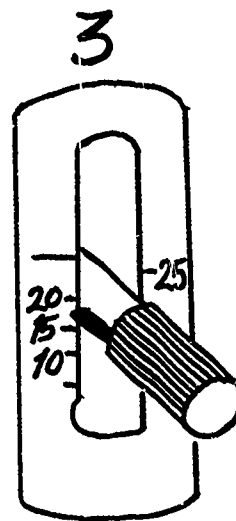
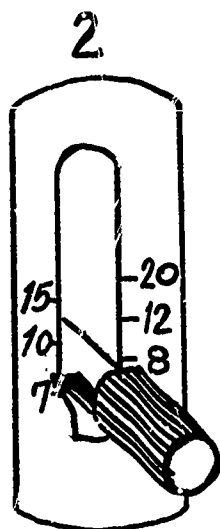
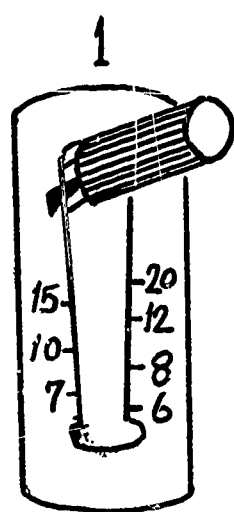

8. Mary's stitch-length regulator is set at 12 stitches per inch. She wants to use a larger stitch on her garment. How should she change the stitch-length regulator?
 1. move it all the way to the top
 2. move it to a smaller number
 3. move it to a larger number

9. Which of the machines shown below is not threaded correctly?

1. A
2. B
3. C

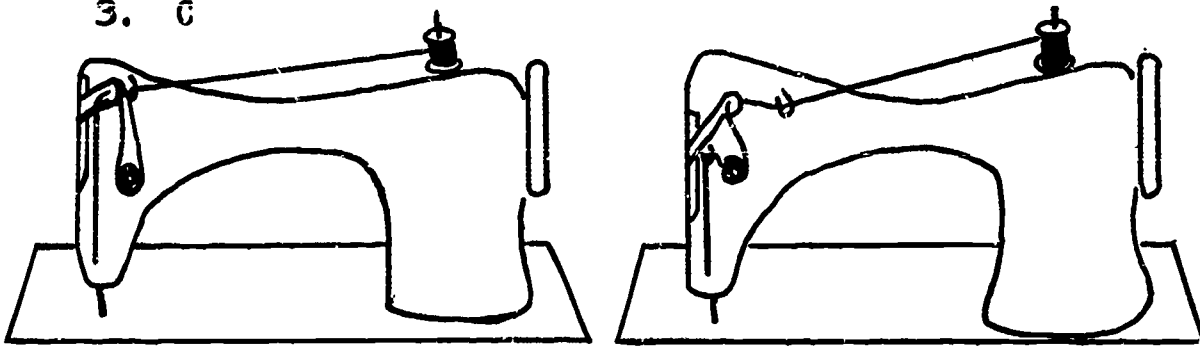

A

B

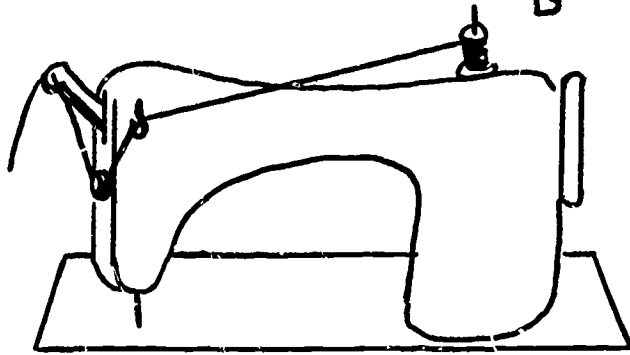

C

10. When the threads in a line of stitching lock on the lower surface of the fabric, which of the statements below would be correct?

1. the upper tension is too loose, so the tension regulator is turned to a smaller number
2. the upper tension is too tight, so the tension regulator is turned to a smaller number
3. the upper tension is too loose, so the tension regulator is turned to a larger number

11. In which of the diagrams is the needle threaded correctly?



1



2



3

12. The general rule for threading needles is that they are threaded from
1. the side of the last thread guide
 2. right to left
 3. left to right
13. Which diagram indicates the correct position for taking the back waist length measurement?

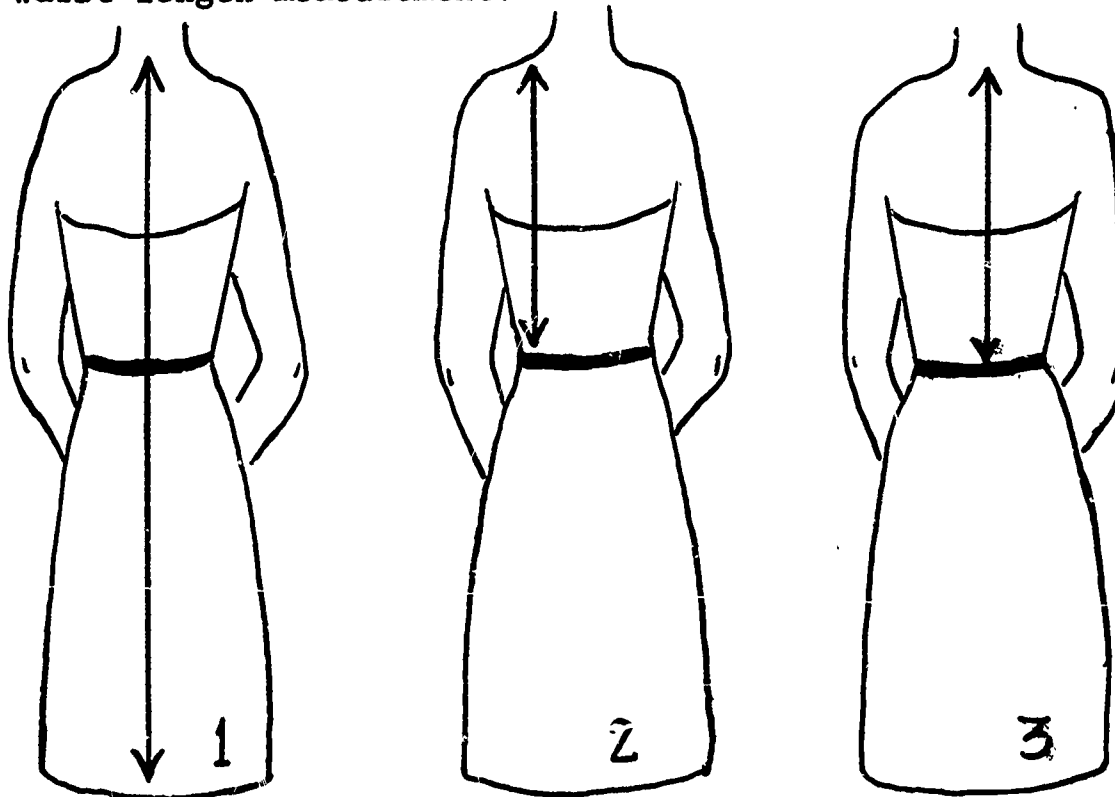

14. If the cutting layout diagram Susie chose looked like the illustration below, what kind of fold should she make in the fabric?

1. lengthwise
2. crosswise
3. bias fold

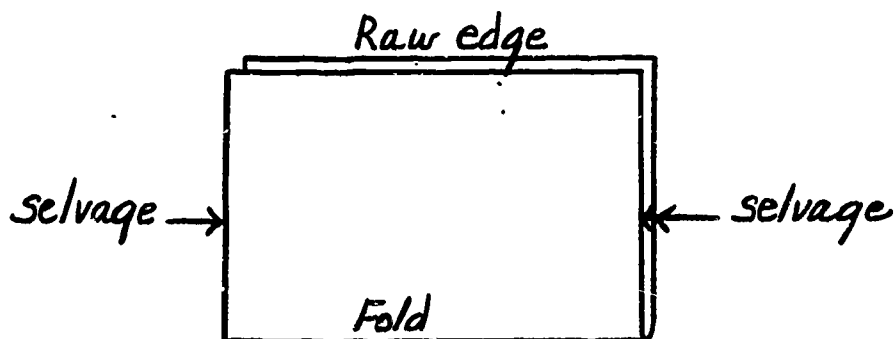

15. Susie's measurements are: bust $31 \frac{1}{2}$ and center back waist length 15. What pattern type and size should she buy?

	<u>Bust</u>	<u>Waist</u>	<u>Hips</u>	<u>Back Waist Length</u>
1. Misses 10	31	24	33	$15 \frac{3}{4}$
2. Junior Petite 5	$31 \frac{1}{2}$	23	33	$14 \frac{1}{4}$
3. Teen 12	32	25	34	15
4. Sub-teen 12	31	25	34	14
5. Junior Miss 11	$31 \frac{1}{2}$	$24 \frac{1}{2}$	$33 \frac{1}{2}$	$15 \frac{1}{4}$

16. Which of the diagrams indicates the correct direction for pulling the fabric to straighten it?

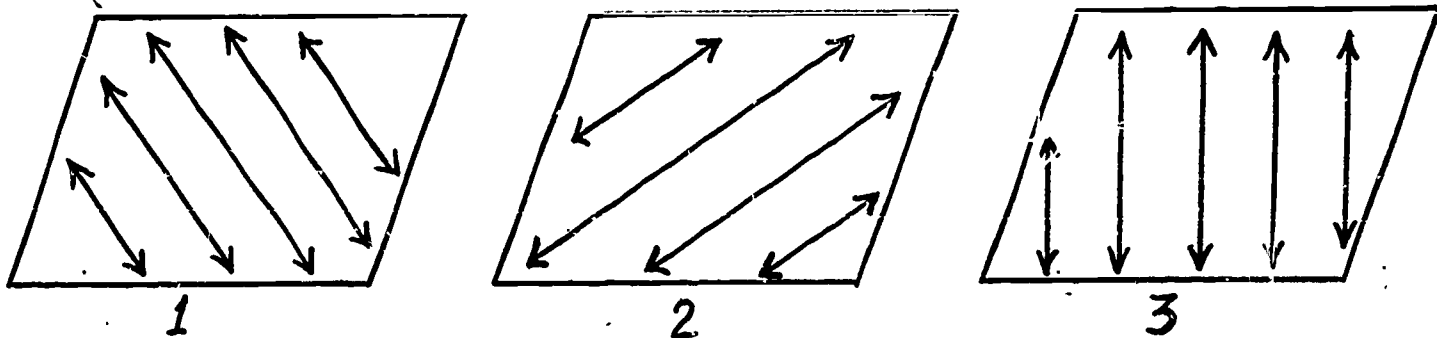

17. How much fabric would need to be purchased for View 2 in a size 12 if the fabric were 44" wide? See chart below.

1. $2 \frac{3}{8}$ yds.
2. 3 yds.
3. $2 \frac{1}{4}$ yds.

View 1	11	13	15	12	14	16
35", 36" fabric	$3 \frac{3}{8}$	$3 \frac{3}{8}$	$3 \frac{1}{2}$	$3 \frac{3}{8}$	$3 \frac{3}{8}$	$3 \frac{5}{8}$
44", 45" fabric	$2 \frac{1}{4}$	$2 \frac{1}{2}$	$2 \frac{1}{2}$	$2 \frac{1}{4}$	$2 \frac{1}{2}$	$2 \frac{1}{2}$
54" fabric	$2 \frac{1}{8}$	$2 \frac{1}{8}$	$2 \frac{1}{8}$	$2 \frac{1}{8}$	$2 \frac{1}{4}$	$2 \frac{1}{4}$

View 2	11	13	15	12	14	16
35", 36" fabric	$2 \frac{7}{8}$	3	3	3	3	$3 \frac{1}{8}$
44", 45" fabric	$2 \frac{1}{4}$	$2 \frac{1}{4}$	$2 \frac{3}{8}$	$2 \frac{3}{8}$	$2 \frac{1}{2}$	$2 \frac{1}{2}$
54" fabric	$1 \frac{3}{4}$	$1 \frac{7}{8}$	$1 \frac{7}{8}$	$1 \frac{3}{4}$	$1 \frac{7}{8}$	2

In items 18-21, match a number from the diagram with each term on the left.

18. seam line
19. seam allowance
20. cutting line
21. place-on-fold line

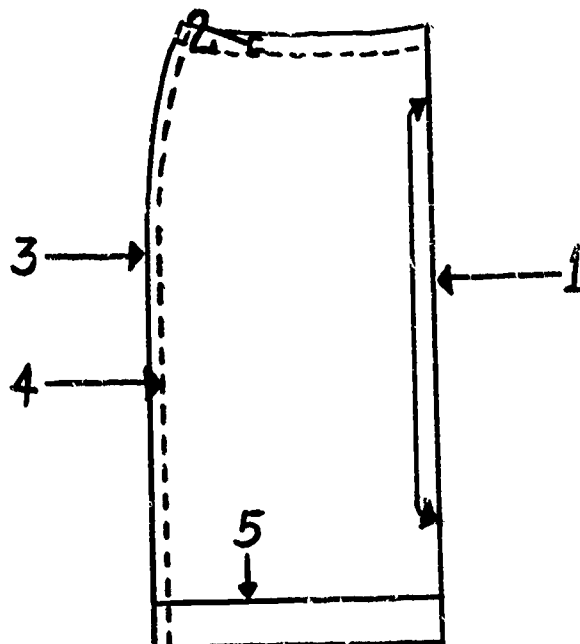

22. In which of the illustrations below has a lengthwise fold been made in the fabric?

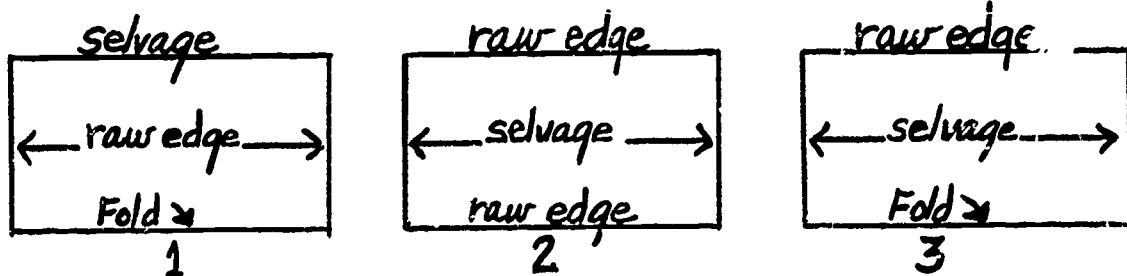

23. Refer to Exhibit D. If Susie bought a size 12 pattern, has fabric 36" wide, and wants to make View 1, which of the circled layout diagrams should she follow?
24. Refer to Exhibit E. In which of the samples is the tracing paper correctly placed?
25. Refer to Exhibit L. In which sample would it be necessary to straighten the ends of the fabric?
26. Refer to Exhibit M. Which of the pattern pieces is pinned correctly as far as grain line is concerned?
27. In which of the diagrams is the staystitching in the correct position in relation to the seam line?

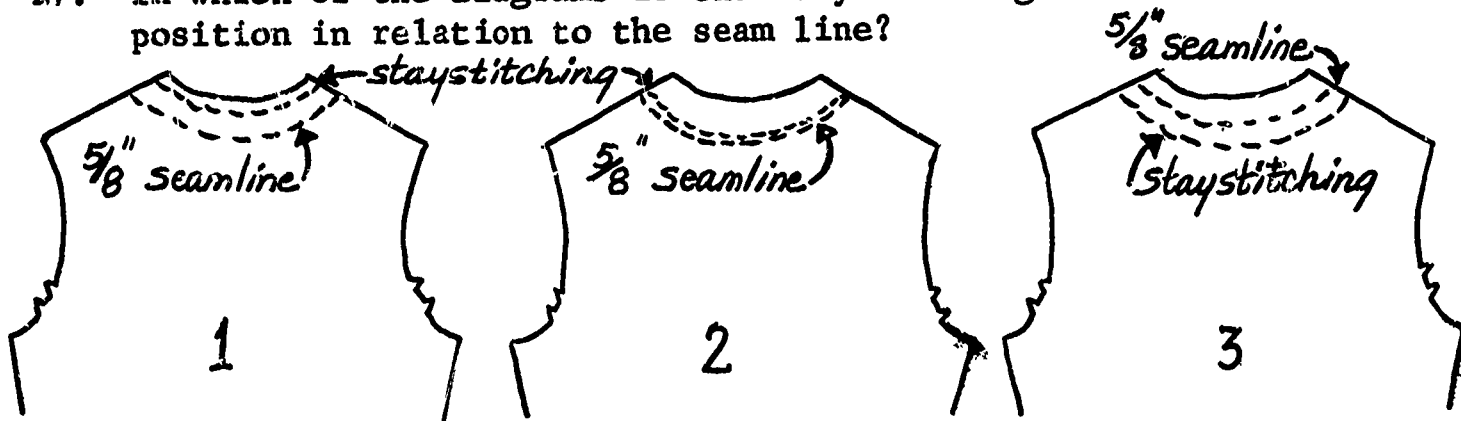

28. Which of these diagrams has lines that correctly indicate the areas that require staystitching on that particular garment unit?

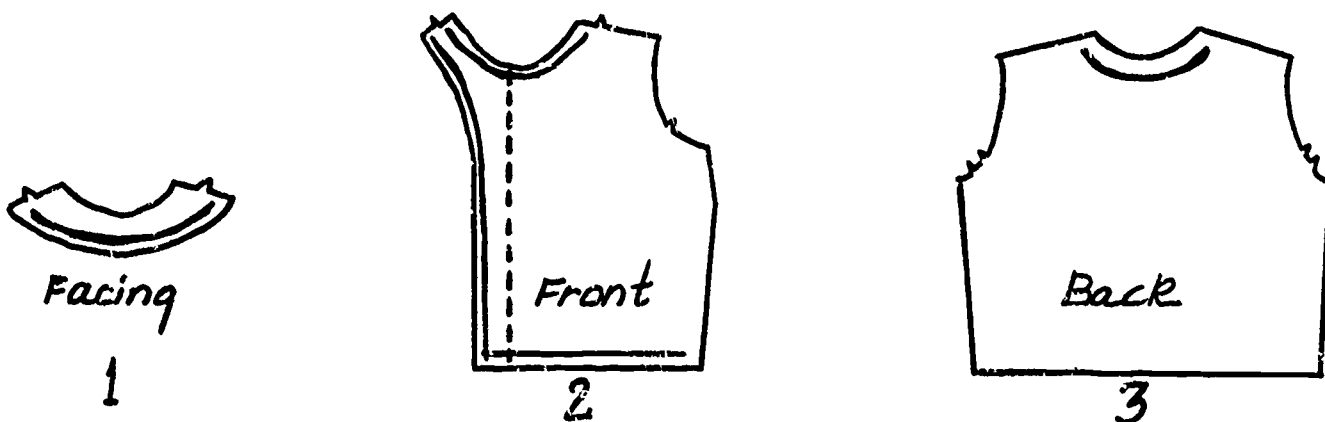

29. The direction for staystitching should be
1. from the narrow to the wide part of the garment unit
 2. upward and away from the center of the garment unit
 3. such that the threads are smoothed down along the cut edge

30. Which of the following diagrams of blouse fronts correctly indicates the edge(s) which require(s) bridgestitching?

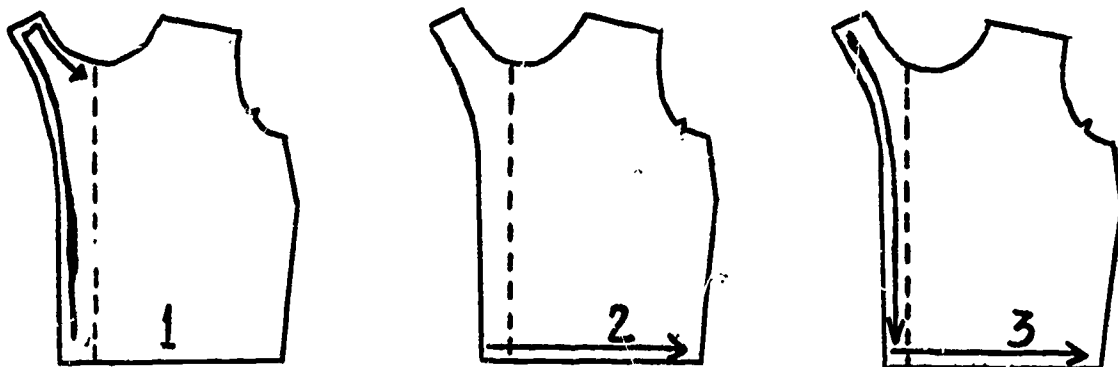

31. In general, bridgestitching should be done on all
1. curved edges of a facing
 2. cut edges which are on straight grain
 3. edges which are to be hemmed or cleanfinished

32. If "B" indicates bridgestitching and "S" staystitching and garment units have been stitched as labeled, which of the diagrams illustrates a garment unit correctly stitched?

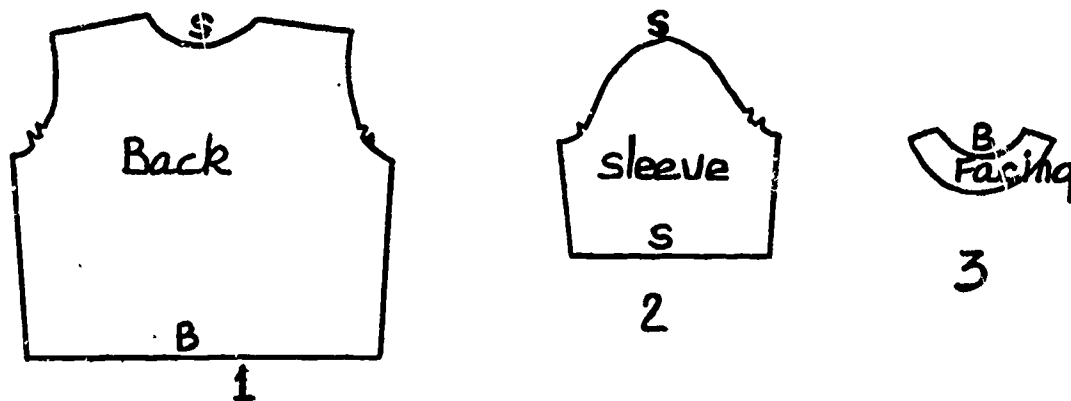

33. Which diagram illustrates correct pinbasting for a dart that is ready to be stitched?

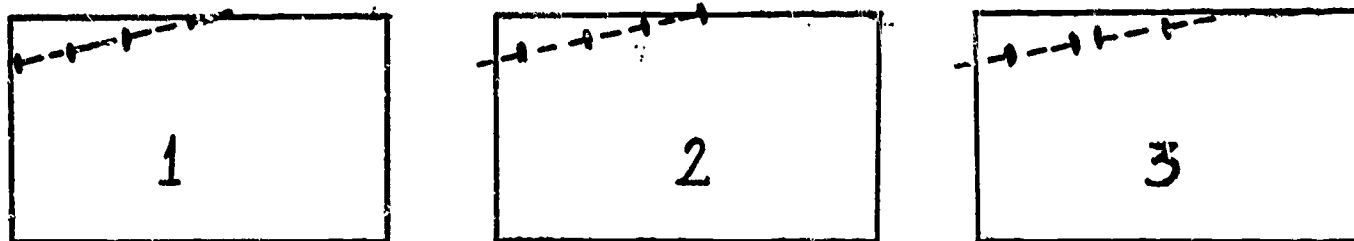

34. In which of these diagrams are the darts in the back unit pressed in the correct direction?



(Dotted lines are the stitching lines)

35. In general, vertical darts should be pressed to the
1. right
 2. left
 3. center
36. In which diagram is the dart placed correctly for beginning the line of stitching?

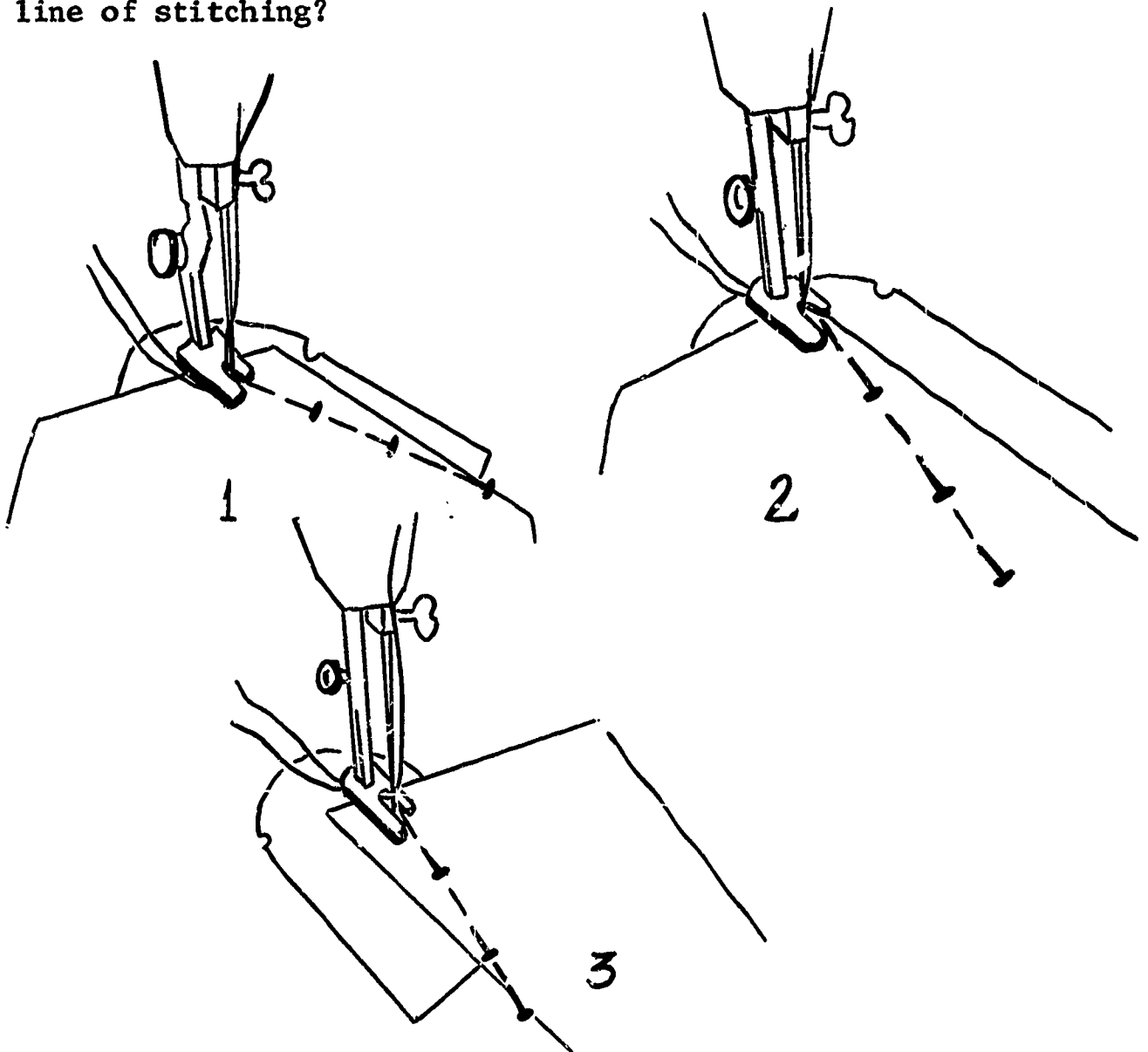

37. Which of the edges of the garment unit shown below need to be cleanfinished?

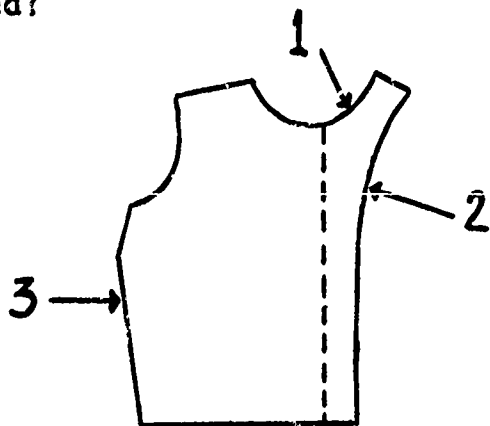

38. Which line indicates the position in which understitching should be done?

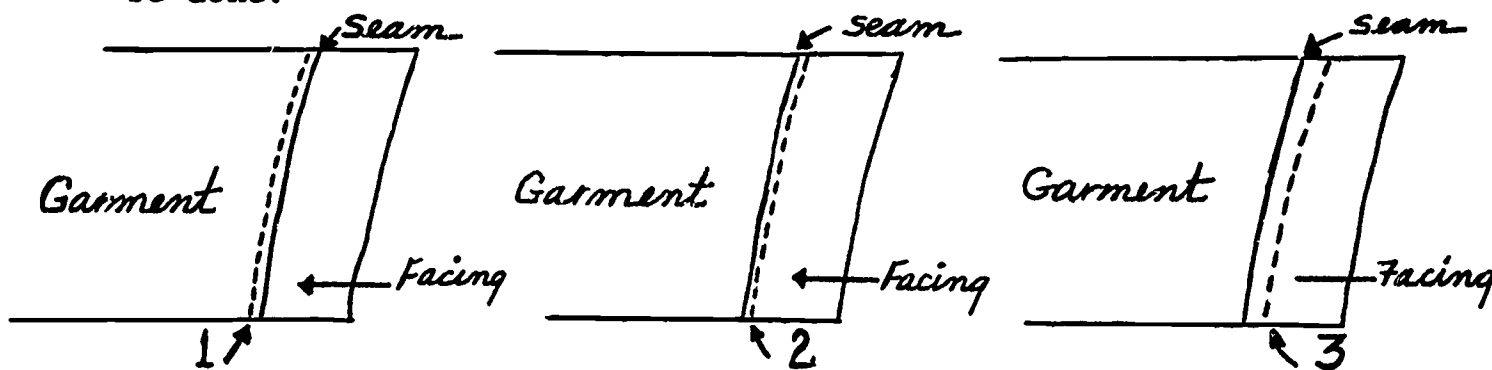

39. If Jane's guide sheet tells her to clip a seam allowance, what should she do?
1. cut into the seam allowance several times at right angles to the seam line
 2. cut off part of the seam allowance parallel to the seam line
 3. cut into the seam allowance at center front
40. Jane is having trouble keeping the neckline facing from showing on the right side of the blouse. What has she probably forgotten to do?
1. staystitch
 2. trim the seam
 3. understitch
41. Suppose you were making a blouse with long sleeves and cuffs. The guide sheet tells you to use ease threads to get the bottom of the sleeve to fit the cuff. Between what numbers should the stitch-length regulator be set for stitching the ease threads?
1. 8-10
 2. 10-12
 3. 12-15

42. When easing a skirt onto a waistband, the pinbasting and stitching should be done with

1. the waistband side up
2. the skirt side up

43. Sue is ready to hem her skirt. How much should she turn under to cleanfinish the edge?

1. $\frac{1}{8}$ "
2. $\frac{1}{4}$ "
3. $\frac{1}{2}$ "

44. Which number points to a curve which should be clipped?

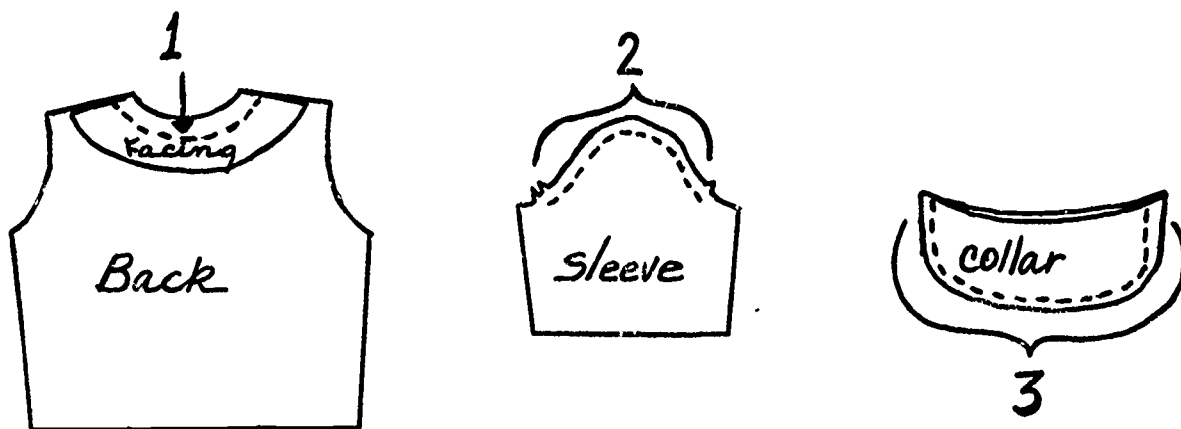

45. Which of these diagrams indicates the correct position of the ease threads on the sleeve?

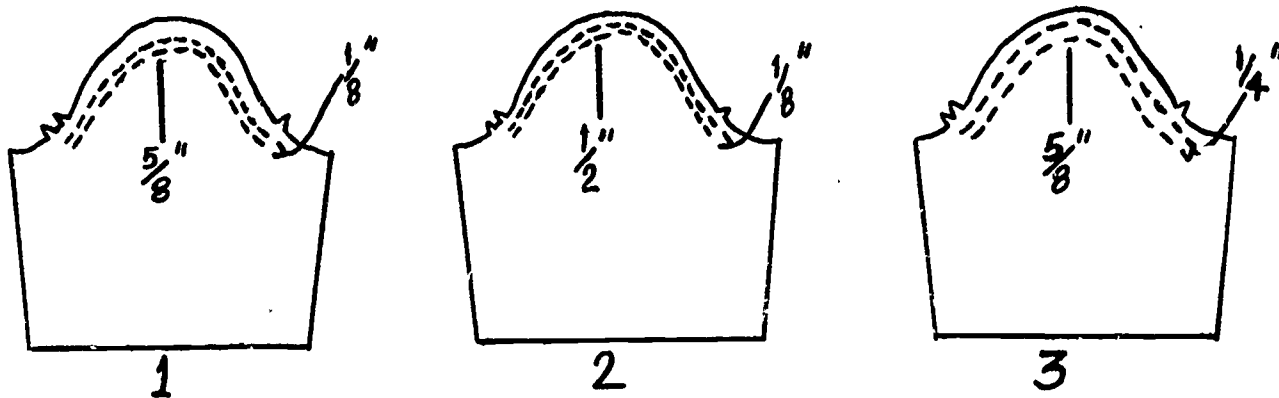

Every procedure recommended in the construction of a blouse has an effect on the finished blouse. Read the results of making certain errors in statements 46-52. Blacken the space on the answer sheet of the number of the error (1-5) that would cause this result. Errors may be used more than once or not at all.

Results

46. The center back is off-grain.

47. The blouse is too short.

48. The shoulder seam is turned to the front at the neckline and to the back at the armhole.

49. The neck edge is stretched out of shape.

50. There are little tucks in the sleeve cap.

51. At the point where the side and armhole seams cross, the side seam is turned to the front rather than open.

52. The point of the dart is too high.

Errors

1. Ease threads were not used.

2. Staystitching was not done.

3. Pressing was not done at a time when it was needed.

4. A pattern of the right size but wrong figure type was chosen.

5. The pattern was incorrectly laid on the fabric.

Every procedure recommended in the construction of a blouse has an effect on the finished blouse. Read the results of omitting certain procedures in statements 53-57. Blacken the space on the answer sheet of the number of the one procedure (1-5) that would be most likely to cause this result if omitted.

Results

53. The facing seam does not remain on the wrong side.

54. The lower front edge and corners are bulky.

55. The shoulder seam of the blouse back is too long and has to be cut off.

56. The cleanfinished edge of the facing does not form a smooth curve.

57. The neckline is not smooth and flat.

Procedures that were not done

1. clipping

2. trimming

3. understitching

4. bridgestitching

5. easing

For items 58-62, blacken the space on the answer sheet of the number of the procedure which should be used for the seam described.

- 58. side seam
- 59. seam attaching fitted facing to neck edge
- 60. seam around the edge of the pocket (pocket is double)
- 61. shoulder seam
- 62. seam attaching fitted facing to armhole

Procedure

- 1. trim
- 2. clip
- 3. trim and clip
- 4. neither trim nor clip



- 63. Refer to Exhibit F. Which sample shows a correctly stitched and secured dart?
- 64. Examine the samples in Exhibit G. Which of the facing seams has been understitched correctly?
- 65. Refer to Exhibit H. In which direction would you staystitch the edge of the skirt indicated in the diagram?

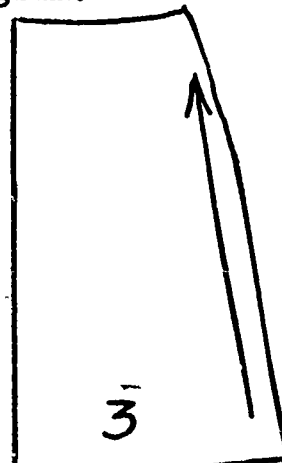
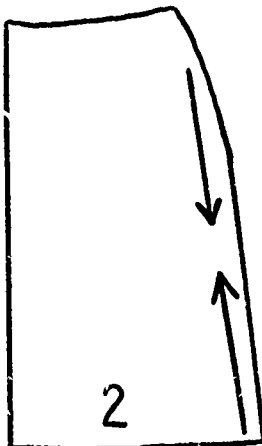
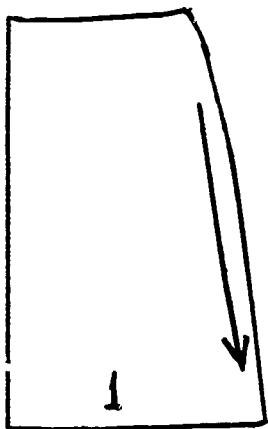

- 66. Refer to Exhibit I. In which of the armholes would the sleeve fit?
 - 1. armhole 1
 - 2. armhole 2
- 67. Refer to Exhibit I. Which letter refers to the front of the sleeve?
 - 1. A
 - 2. B

68. Refer to Exhibit O. In which of these diagrams of a shift is the direction of staystitching correctly indicated?



69. Refer to Exhibit J. In which of the samples is the facing correctly placed?
70. Refer to Exhibit K. Which sample indicates the correct position for cleanfinishing a raw edge?

Refer to Exhibit N. Examine the blouse and answer questions 71-80.

71. Is the stitch length in both side seams correct?
1. yes
2. no
72. Fill in the number of the underarm dart which is pressed in the correct direction.
73. Fill in the number of the shoulder dart in which the stitching line is tapered correctly.
74. Was the facing seam allowance trimmed correctly?
1. yes
2. no
75. Was the facing seam allowance clipped correctly?
1. yes
2. no
76. Fill in the number of the sleeve which has the necessary points matched.
77. Fill in the number of the sleeve in which the ease has been evenly distributed.
78. Fill in the number of the corner of the hem which has been finished correctly.
79. Fill in the number of the corner of the blouse at the neckline which has been pulled out to form a square corner.
80. Fill in the number of the sleeve in which the hem has been turned up on grain.

EXHIBITS ACCOMPANYING APPLICATION TEST

A brief description of each of the exhibits referred to in the application test is given below.

- Exhibit A - Three samples of stitching--tension correctly adjusted in sample 1, upper tension too loose in sample 2, and upper tension too tight in sample 3
- Exhibit B - Three samples of stitching--upper tension too loose in sample 1, tension correctly adjusted in sample 2, and upper tension too tight in sample 3
- Exhibit C - One sample of stitching with upper tension too tight
- Exhibit D - Simplicity Guide Sheet #5418 with three cutting layouts circled
- Exhibit E - Three pattern pieces ready for marking with tracing paper inserted correctly in example 1 and incorrectly in examples 2 and 3
- Exhibit F - Samples of darts with sample 1 stitched correctly, sample 2 backstitched, and sample 3 stitched off the traced line and past the point
- Exhibit G - Samples of three necklines with facings attached and understitched--sample 1 understitched correctly, sample 2 with the understitching showing on the right side, and sample 3 with the understitching not going through the seam allowance
- Exhibit H - A sample A-line skirt front
- Exhibit I - A bodice with side and shoulder seams stitched and a sleeve ready to be inserted--notches on sleeve labeled "A" and "B" and blouse armholes labeled "1" and "2"
- Exhibit J - Three samples of necklines with facings pinned to the neckline--wrong side of facing pinned to right side of neckline in sample 1, sample 2 with facing correctly placed, and sample 3 with facing pinned to wrong side of fabric
- Exhibit K - Three samples of cleanfinishing--sample 2 correctly stitched, and samples 1 and 3 with the lines of stitching too far from the edge
- Exhibit L - Three pieces of fabric--samples 1 and 2 with torn edges and sample 3 with a cut edge
- Exhibit M - A piece of fabric with three pattern pieces pinned to it--samples 1 and 2 pinned off-grain, sample 3 pinned on-grain

Exhibit N - A blouse with one side made correctly and the following errors made on the other side: dart pressed in wrong direction, dart puckers, sleeve inserted off-grain, sleeve hemmed off-grain, corner of hem finished incorrectly, and neckline seam untrimmed

Exhibit O - A bodice front with a round neckline

BLOUSE RATING SCALE

Student _____ School _____ Judge _____ Date _____
 _____ 3 _____ 2 _____ 1 _____ Score _____

GENERAL APPEARANCE

- | | | | |
|---|-----------------------------------|--|---------|
| * 1. No tracing of dressmaker carbon shows on the right side | shows in one or two places | shows in more than two places | 1 _____ |
| 2. Thread blends with fabric throughout garment | _____ | thread is off color or too dark or too light | 2 _____ |
| 3. Blouse is free from soil | slightly soiled | soiled | 3 _____ |
| 4. There is no evidence of scorching | scorched slightly in one place | scorched in more than one place or badly scorched in one place | 4 _____ |
| 5. Garment has no undesirable shine on right side resulting from incorrect pressing | _____ | has undesirable shine on right side | 5 _____ |
| 6. There are no imprints of darts or seams on the right side | imprints in one or two places | in more than two places | 6 _____ |
| 7. There are no ends of threads showing on the right side more than 1/16" | one end of a thread shows > 1/16" | two or more threads show > 1/16" | 7 _____ |
| 8. All threads on the wrong side are trimmed to within 1" | one is not trimmed | more than one is not trimmed | 8 _____ |

*Refer to "Instructions for the Judges."

* 9. No seams are coming apart because of broken thread a seam is coming apart in one place seams are coming apart in more than one place 9. _____

GRAINLINE OF SLEEVE

*10. Left sleeve is on grain ($< 1/8"$) off grain $\geq 1/8"$ $< 3/8"$ off grain $\geq 3/8"$ 10. _____

*11. Right sleeve is on grain ($< 1/8"$) off grain $\geq 1/8"$ $< 3/8"$ off grain $\geq 3/8"$ 11. _____

STAYSTITCHING OF NECKLINE

*12. Both back and both front necklines are staystitched back and one front staystitched back or two front neck- lines staystitched **! 12. _____

*13. Staystitched with 12 or more stitches per inch 9 to 11 stitches ≤ 8 stitches ! 13. _____

*14. Staystitched within $1/8"$ of marked seam line $> 1/8"$ $\leq 1/4"$ from seam line on some places $> 1/4"$ in some places ! 14. _____

*15. Staystitching does not show on right side any place shows in one or two places shows in three or more places ! 15. _____

PLAIN SEAMS

*16. There is one line of stitching on both shoulder seams second line on part of one seam two or more lines on both seams 16. _____

*17. There is one line of stitching on both side seams second line on part of one seam two or more lines on both seams 17. _____

** It is possible to have no points.

*18.	There is one line of stitching on both <u>armseye</u> seams	second line on part or all of one armseye seam	second line on part or all of both armseye seams	18 _____
*19.	<u>Shoulder</u> seams are even in width (within 1/16")	differ in width between widest and narrowest place by $\geq 1/16"$ < 1/4"	difference in width $\geq 1/4"$	19 _____
*20.	Side seams are even in width (within 1/16")	differ in width between the widest and narrowest place by $\geq 1/16"$ < 1/4"	difference in width $\geq 1/4"$	20 _____
*21.	<u>Armseye</u> seams are even in width (within 1/8")	differ in width between the widest and narrowest place by $\geq 1/8"$ < 3/8"	difference in width $\geq 3/8"$	21 _____
*22.	Shoulder seams are stitched straight	straight except for one or two places	crooked in three or more places	22 _____
*23.	Side seams are stitched straight	straight except for one or two places	crooked in three or more places	23 _____
*24.	Average width of <u>shoulder</u> seams is (pressed open) $\geq 1 1/8"$ < 1 3/8"	average width is $\geq 1"$ < 1 1/8" or $\geq 1 3/8"$ $\leq 1 1/2"$	average width is < 1" or $> 1 1/2"$	24 _____
*25.	Average width of <u>side</u> seams is (pressed open) $\geq 1 1/8"$ < 1 3/8"	average width is $\geq 1"$ < 1 1/8" or $\geq 1 3/8"$ $\leq 1 1/2"$	average width is < 1" or $> 1 1/2"$	25 _____
*26.	Average width of <u>armseye</u> seams is $\geq 1 1/8"$ < 3/8"	average width is $\geq 1"$ < 1 3/8" or $\geq 1 1/2"$ $\leq 1 1/2"$	average width is < 1" or $> 1 1/2"$	26 _____

- | | | | | |
|------|---|--|---|------------|
| 27. | Notches on armseye seam are in right combination--single with single, double with double | _____ | notches are not in right combination on one armseye seam | ! 27 _____ |
| *28. | Notches on both side seams match or miss matching by no more than 1/16" | notches miss matching
> 1/16" < 1/8" | one or both sets of notches miss matching by more than 1/8" | ! 28 _____ |
| 29. | None of the 4 sets of notches on armseye seams miss matching by more than 1 or 2 threads | one or two sets of notches miss matching by 2 threads to 1/8" | three or more sets miss matching by more than 2 threads | ! 29 _____ |
| *30. | At intersections of shoulder and armseye seam both shoulder seams are stitched open | one or two corners caught in seam | one shoulder seam is stitched open | ! 30 _____ |
| *31. | Both shoulder seams are pressed open and flat | one seam pressed open | seams pressed open but with insufficient moisture to keep them flat | ! 31 _____ |
| 32. | There is slight ease in the two back shoulder seams | there is no ease or too much ease in one shoulder seam | there is no ease or too much ease in both shoulder seams | 32 _____ |
| *33. | Ease in both shoulder seams is evenly distributed | there is a pucker in one shoulder seam | there is a pucker in both shoulder seams or there is <u>no ease</u> in shoulder seams | 33 _____ |
| *34. | At intersections of side seams with armseye seams and hem (4 places) all <u>side</u> seam intersections are stitched open | three intersections are stitched open or one or two corners caught in seam | one or two intersections are stitched open | ! 34 _____ |

- | | | | | |
|------|--|--|---|------|
| *35. | Both side seams are pressed open and flat | one seam pressed open | seams pressed open but with insufficient moisture to keep them flat | ! 35 |
| *36. | There are no puckers or pleats in the <u>side seam</u> | one side seam has a pucker or pleat | both side seams have a pucker or pleat | ! 36 |
| *37. | At <u>intersections</u> of underarm sleeve seams with armseye seams and hems (4 places) all <u>underarm seam intersections</u> are stitched open | three underarm seam intersections are stitched open or one or two corners caught | one or two underarm seam intersections are stitched open | ! 37 |
| *38. | Both underarm sleeve seams are pressed open and flat | one seam pressed open | seams pressed open but with insufficient moisture to keep them flat | ! 38 |
| *39. | There are no puckers or pleats in the <u>underarm sleeve seam</u> | one sleeve seam has a pucker or pleat | both sleeve seams have a pucker or pleat | ! 39 |
| *40. | Tension of stitching on <u>right side seam</u> looks like sample A | tension looks like sample B | tension looks like sample C | 40 |
| *41. | Tension on <u>right armseye</u> looks like sample A | tension looks like sample B | tension looks like sample C | 41 |
| *42. | Tension on facing <u>understitching</u> looks like sample A | tension looks like sample B | tension looks like sample C | 42 |
| *43. | Tension on <u>blouse hem</u> looks like sample A | tension looks like sample B | tension looks like sample C | 43 |

44.	Intersecting <u>right armseye</u> and underarm seams coincide or miss by $< 1/16$ "	miss coinciding by $\geq 1/8$ "	miss coinciding by $\geq 1/8$ "	44 _____
45.	Intersecting <u>left armseye</u> and underarm seams coincide or miss by $< 1/16$ "	miss coinciding by $\geq 1/8$ "	miss coinciding by $\geq 1/8$ "	45 _____
46.	The number of stitches per inch for the <u>left side seam</u> is ≥ 12	9-11 per inch	≤ 8 per inch	46 _____
47.	The number of stitches per inch for the <u>neckline seam</u> is ≥ 12	9-11 per inch	≤ 8 per inch	47 _____
48.	The number of stitches per inch for the <u>left armseye seam</u> is ≥ 12	9-11 per inch	≤ 8 per inch	48 _____
49.	The number of stitches per inch on the blouse hem is ≥ 12	9-11	≤ 8 per inch	49 _____
*50.	<u>Shoulder seams</u> are the same length or one is longer by $\leq 1/16$ "	differ in length by $> 1/16$ " $< 3/16$ "	differ in length by $\geq 3/16$ "	50 _____
*51.	<u>Side seams</u> are the same length or one is longer by $\leq 1/16$ "	differ in length by $> 1/16$ " $< 1/8$ "	differ in length by $\geq 1/8$ "	51 _____
*52.	Underarm sleeve seams are the same length or one is longer by $\leq 1/16$ "	differ in length by $> 1/16$ " $< 1/8$ "	differ in length by $\geq 1/8$ "	52 _____



*53. Armseye seams are the same length or one is longer by $\leq 1/8"$

differ in length by $> 1/8" < 1/4"$

53 _____

NECKLINE FACING:

*54. Lengthwise grain of the facing matches lengthwise grain of garment

misses matching grain by $< 1/8"$

misses matching grain by $> 1/8"$ or is cut on crosswise grain

54 _____

55. Width of the two short facing seams at shoulders are $3/8"$ to $1/2"$ (pressed open)

$> 1/2" \leq 1"$

$> 1"$ or $< 3/8"$

55 _____

56. Facing and shoulder seams coincide or miss by no more than 2 threads

one facing seam is farther from shoulder seam than 2 threads

both facing seams are farther from shoulder seams than 2 threads

56 _____

*57. Bridgestitching line is on the folded edge or slightly to the wrong side

bridgestitching line is on the right side of the facing in one or two places

bridgestitching line is on right side most of the way

57 _____

58. Free edges of the facing form a smooth curve or straight edge

curved or straight edges are irregular in one or two places

curved or straight edges are irregular in more than two places

58 _____

59. Stitched within $1/8"$ from the turned edge for the entire facing

stitched $> 1/8"$ for part of the facing

stitched $> 1/8"$ for most of the facing

59 _____

- | | | | | |
|-----|---|---|-------------|------------|
| 50. | Outer edge of neckline facing is attached to the shoulder seam at each shoulder | attached at <u>one</u> shoulder seam | _____ | ! 60 _____ |
| 61. | Tacking does not show on right side at either shoulder | shows on one shoulder | _____ | ! 61 _____ |
| 62. | Neckline seam is on or very near the marked curve | seam leaves the marked curve in four or more places | _____ | 62 _____ |
| 63. | Neckline seam is trimmed $> 1/8" \leq 1/4"$ | trimmed, but seam is $> 1/4"$ | $\leq 1/8"$ | ! 63 _____ |
| 64. | Neckline seam is clipped to within one or two threads | clipped farther from seam than two threads | _____ | ! 64 _____ |
| 65. | Spaces between clippings are $1/2"$ | $> 1/2" \leq 3/4"$ | $> 3/4"$ | ! 65 _____ |
| 66. | Facing is understitched within $1/8"$ in $1/8"$ of the neckline seam | understitched within $1/8"$ in all but two places | _____ | 66 _____ |
| 67. | Understitching continued to within $1"$ of each corner | continued to within $1"$ of one corner only | _____ | 67 _____ |
| 68. | Understitching catches the seam allowance all the way | fails to catch seam allowances in one or two places | _____ | 68 _____ |
| 69. | Understitching threads are pulled to the wrong side at each end | pulled to the wrong side on one end only | _____ | ! 69 _____ |

- *70. Neckline corners are turned so they approximate right angles turned so one does, but the other does not approximate a right angle 70 _____
71. Facing does not roll to the right side rolls to the right side in more than two places 71 _____

DARTS

72. There are single traced straight lines for both shoulder darts on both darts there are double traced lines or traced lines that are crooked 72 _____
73. For both shoulder darts a small crossline was traced to mark the end of the dart crossline for one dart only ! 73 _____
- *74. On shoulder darts stitching tapers evenly at the points so there are no puckers pucker at the point of one shoulder dart 74 _____
75. On shoulder darts stitching coincides with traced lines with traced lines on one dart stitching misses traced lines on both darts 75 _____
- *76. On shoulder darts stitching tapers correctly stitching does not taper correctly on both darts 76 _____
77. Threads are hand tied securely at the points of shoulder darts threads at the points of both darts are too loosely tied ! 77 _____
78. There are single traced straight lines for both underarm darts on both darts there are double traced lines or traced lines that are crooked 78 _____

- | | | | | |
|------|---|---|--|------------|
| 79. | For both underarm darts a crossline was traced to mark the end of the dart | crossline for one dart only | _____ | ! 79 _____ |
| *80. | On underarm darts stitching tapers evenly at the points so there are no puckers | pucker at the point of one underarm dart | pucker at the point of both underarm darts | 80 _____ |
| 81. | On underarm darts stitching coincides with traced lines | stitching coincides with traced lines on one dart | stitching misses traced lines on both darts | 81 _____ |
| *82. | On underarm darts stitching tapers correctly | stitching tapers correctly on one dart | stitching does not taper correctly on both darts | 82 _____ |
| 83. | Threads are hand tied securely at the points of underarm darts | threads at the point of one dart are not tied or loosely tied | threads at the points of both darts are too loosely tied | ! 83 _____ |
| 84. | At shoulder darts tied threads are trimmed 1/8" to 3/4" | one is shorter than 1/8" or longer than 3/4" | both are shorter than 1/8" or longer than 3/4" | 84 _____ |
| 85. | At underarm darts tied threads are trimmed 1/8" to 3/4" | one is shorter than 1/8" or longer than 3/4" | both are shorter than 1/8" or longer than 3/4" | 85 _____ |
| *86. | Where the shoulder dart crosses the seam there are no puckers or pleats of the type that would occur as a result of not pressing the seam | puckers or pleats on the dart at one shoulder seam | puckers or pleats on both darts at shoulder seams | 86 _____ |

87. Where the underarm dart crosses, the seam there are no puckers or pleats
 puckers or pleats on both darts at side seams
 87 _____
88. Shoulder darts are pressed toward center back
 one shoulder dart is pressed toward center back and one toward the armseye
 both are pressed toward the armseye
 ! 88 _____
89. Underarm darts are pressed toward the hem
 one pressed toward hem and one toward armseye
 both are pressed toward the armseye
 ! 89 _____
- SLEEVE
90. Tracing on sleeve caps is 5/8" from the edge at center of sleeve cap
 $1/2"$ to $3/4"$
 $> 3/4"$ or $< 1/2"$
 ! 90 _____
- *91. Center of sleeve cap matches shoulder seam on both sleeves
 misses by $< 1/4"$
 misses by $\geq 1/4"$ on either or both sleeves
 ! 91 _____
92. Dots on sleeve cap match dots on armholes
 one or more pair of dots miss matching by $1/16"$ to $1/4"$
 miss matching by $> 1/4"$
 ! 92 _____
93. No ease threads show on the right side
 show in one, two or three places
 show in four or more places
 93 _____
94. Left armseye seam stitched very near the marked curve on the sleeve side
 deviates from the curve in one, two, or three places
 deviates from the curve in four or more places
 94 _____
95. Right armseye seam stitched very near the marked curve on the sleeve side
 deviates from the curve in one, two, or three places
 deviates from the curve in four or more places
 95 _____

96. Left sleeve is eased into the armhole so evenly that there are no puckers or pleats
 there are one, two or three pleats or places with puckers
 there are more than three pleats or places with puckers
 96
97. Right sleeve is eased into the armhole so evenly that there are no puckers or pleats
 there are one, two or three pleats or places with puckers
 there are more than three pleats or places with puckers
 97
98. Second stitching in lower part of armhole is consistently within 1/4" of the stitched seam line
 farther than 1/4" from the seam line on one sleeve
 farther than 1/4" from the seam line on both sleeves
 98
- *99. Lower part of the left armseye seam is clipped to within one or two threads of the second line of stitching
 clipped more than one or two threads < 1/8"
 clipped $\geq 1/8"$ or clipped beyond second line of stitching
 99
- *100. Lower part of the right armseye seam is clipped to within one or two threads of the second line of stitching
 clipped more than one or two threads < 1/8"
 clipped $\geq 1/8"$ or clipped beyond second line of stitching
 100
- *101. Clipping on both armseye seams is at intervals of 1/2" or less
 at intervals > 1/2"
 at intervals $\geq 3/4"$
 101
- SLEEVE HEM
- *102. The hem on the left sleeve is even in width
 varies in width 1/8" or less
 varies in width more than 1/8"
 102
- *103. The hem on the right sleeve is even in width
 varies in width 1/8" or less
 varies in width more than 1/8"
 103
104. The right sleeve hem is the same width as the left sleeve hem
 one hem is 1/8" to 1/4" wider than the other
 one hem is more than 1/4" wider than the other
 104

*105.	The stitch of the hem is within 1/8" from the turned edge	> 1/8" < 3/16"	≥ 3/16"	105
*106.	The stitch of the hem catches the fold all the way on both sleeves	stitch runs off the fold in one or two places	stitch runs off the fold in three or more places	106
107.	Stitching ends overlap 1/4" to 1/2" on both sleeves	> 1/2" < 3/4" on one or both sleeves	< 1/4" > 3/4" on one or both sleeves	107
108.	There are no puckers or diagonal wrinkles resulting from putting the hem in off-grain	puckers or diagonal wrinkles on one sleeve	on both sleeves	108
BLOUSE HEM				
*109.	The first turning of the hem is on the bridgestitch line or the bridgestitch line is turned with the exception of one place	bridgestitching shows on the hem in two or three places	shows in four or more places or all the way	! 109
*110.	The first turning of the hem averages 1/4" to 5/16"	between 1/8" and 1/2" (but not 1/4" to 5/16")	< 1/8" or > 1/2"	110
111.	There are no raw edges showing on the hem	raw edge is showing in one place	showing in more than one place	111
112.	Stitching of the hem is within 1/8" from the turned edge	> 1/8" < 3/16"	≥ 3/16"	! 112
113.	Stitching of the hem catches the fold all the way	stitch runs off the fold in one or two places	stitch runs off the fold in three or more places	! 113
*114.	The hem is even in width (1/16")	varies in width ≥ 1/16" < 1/8"	varies in width ≥ 1/8"	! 114



- | | | | |
|---|--|---|-------------|
| 115. Threads at ends of hem are pulled to the wrong side and secured | secured at only one end of the hem | _____ | ! 115 _____ |
| *116. Lower edges of extended front facing are faced rather than hemmed | _____ | lower edges are hemmed | 116 _____ |
| *117. Seams at "K" are trimmed to within 1/4" | one seam is trimmed | _____ | ! 117 _____ |
| *118. Seams at "K" are pressed so they lie flat | one is pressed | _____ | ! 118 _____ |
| *119. Both lower corners approximate right angles | one corner deviates from a right angle | neither corner approximates a right angle | 119 _____ |
| 120. Bottom edge of hem is pressed sharp | slightly pressed | _____ | ! 120 _____ |
| 121. There are no diagonal wrinkles resulting from putting the hem in off-grain | one or two diagonal wrinkles | more than two wrinkles | 121 _____ |

INSTRUCTIONS TO THE JUDGES

1. Tracing should show on the wrong side without showing on the right side.
9. Look especially at: neckline and facing corners, side seam, underarm seam, armseye seams.
- 10, 11. Hand baste with colored thread from intersection of underarm and armhole seam on right sleeve along the crosswise grain toward the outer fold line. Lay right sleeve on the table so blouse front faces upward as illustrated. Hand crease along the stitching of seam at "A" and at the opposite side. Pin at "B" and "C".

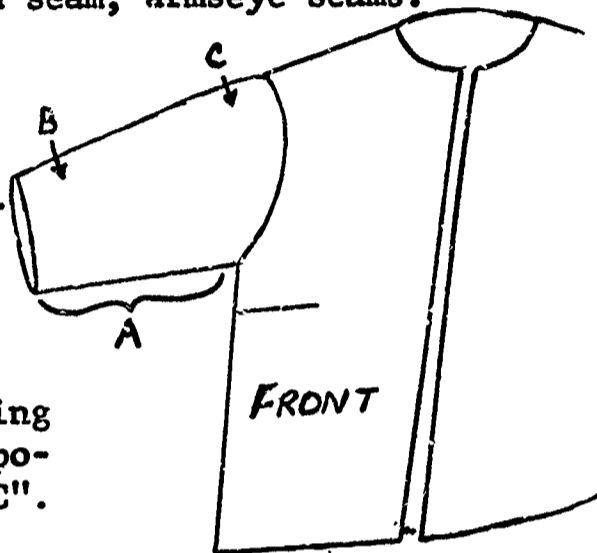

Place the triangle as illustrated in diagrams. One side of the right angle coincides with the crosswise grain of sleeve at "D". Measure "E", the distance in inches between the point of the triangle and the edge of the sleeve. The point of the triangle may be above the edge of the sleeve, on the edge, or below the edge. When the grain line is perfect, the point of the triangle is on the edge of the sleeve.

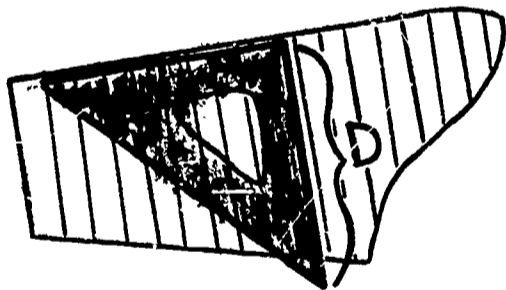

(1)
triangle on edge
(correct)

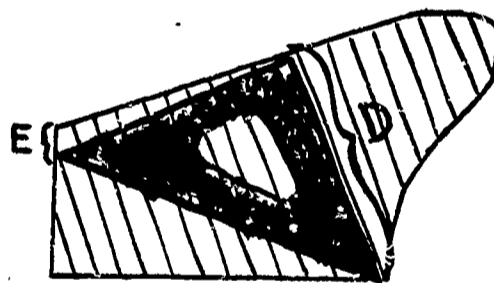

(2)
triangle below edge

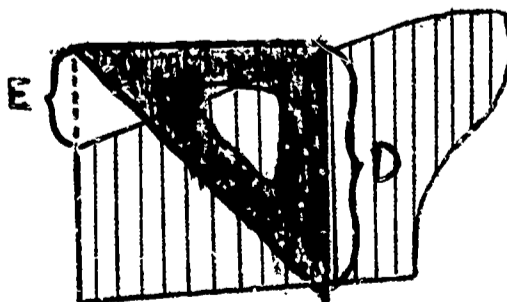

(3)
triangle above edge

- 12, 14. Measure from marked seam line.
If marked seam line cannot be seen,
measure from stitched seam line.

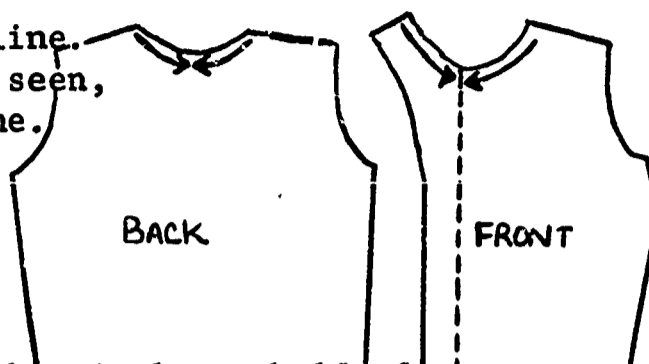

18. Do not count reinforcing stitches in lower half of armseye.
Look on the blouse side of armseye instead of sleeve side.
- 19, 20, 21. Measure seams on both right and left side of garment.
Use clear see-through ruler. Measure to within 1/16".
Measure ravel of seam allowance (This is considered part of the
seam allowance).
If there are two lines of stitching, measure from the one
farthest away from the raw edge.
Do not measure where there are notches.
The narrowest place may be on the right shoulder seam and the
widest on the left shoulder or vice versa or the narrowest
and widest may be on the same side.
Compute the difference between the largest and the narrowest
part of the seam allowance.

Examples:

Note: The widest may be on the
right side and the narrowest
on the left or vice versa, or
they may both be on the same
seam.



Difference = 3/8"



Difference = 1/8"

20. At the dart measure at "B", as illustrated.

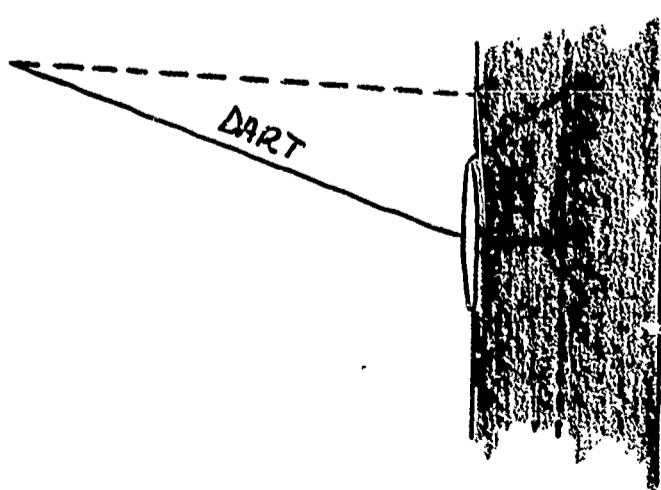

21. Armseye seams are pressed together. Lay the ruler on the seam line so that the one-inch line of the ruler coincides with the seam line at points "A" and "B".

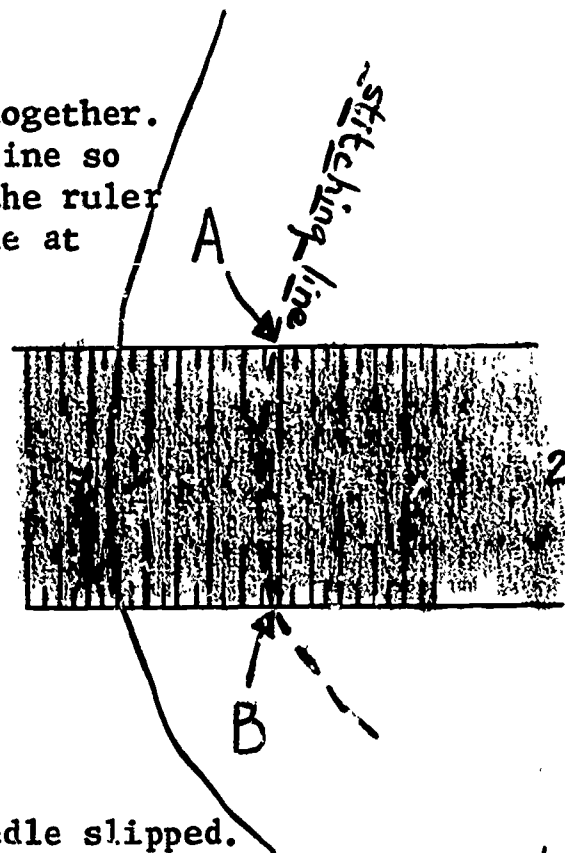

- 22, 23. Count the times the needle slipped.

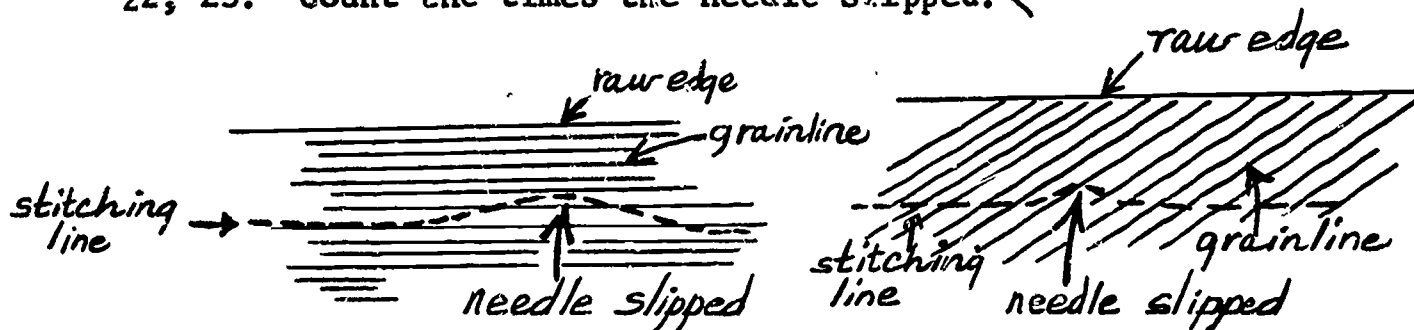

Straight Edge.

Bias Edge.

- 24, 25, 26. To compute average seam width

- (1) measure at widest place on either the right or left half of the garment
- (2) measure at narrowest place on either the right or left half of the garment
- (3) average these two

Example:

$$\begin{aligned}
 \text{Average} &= \frac{12}{8} + \frac{7}{8} \div 2 \\
 &= \frac{19}{8} \div 2 = \frac{19}{16} \\
 &= 1 \frac{3}{16}
 \end{aligned}$$

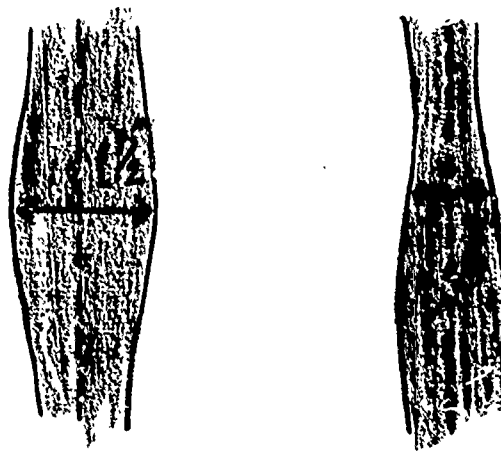

28. Hold ruler in the direction of the arrow in the illustration.

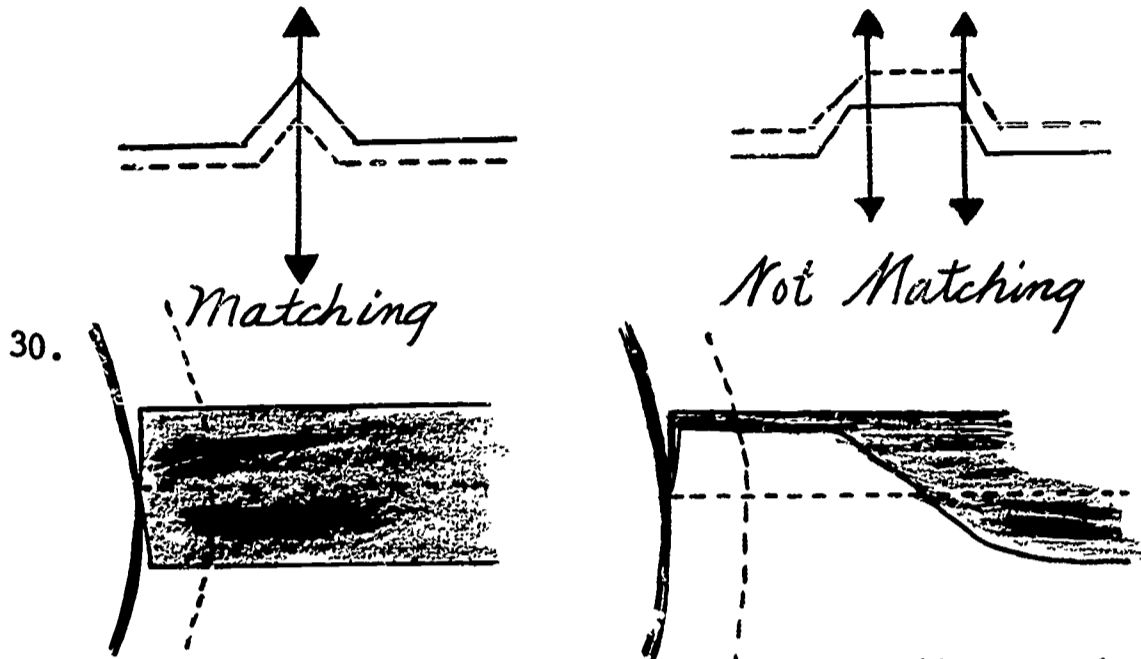

30, 34, 37. Ignore pleat or pucker. This will be evaluated later.

31, 35, 38. Feel with your fingers as well as observe this.

32, 36, 39. Puckers or pleats in a seam.

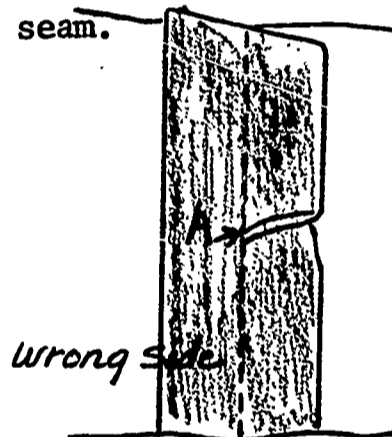

40, 41. Right side seam means the seam that is on the right side when the blouse is worn.

(tension) Sample of stitching with satisfactory tension adjustment

A

Sample of stitching with upper tension somewhat tight

B

Sample of stitching with upper tension tighter than in sample B

C

42.

(under-stitching) Sample of under stitching with satisfactory tension adjustment

A

Sample of under-stitching with upper tension somewhat tight

B

Sample of under-stitching with upper tension tighter than in sample B

C

- | | | | |
|-----|---|--|--|
| 43. | Sample of stitching on hems with satisfactory tension adjustment
A | Sample of stitching on hems with upper tension somewhat tight
B | Sample of stitching on hems with upper tension tighter than in Sample B
C |
|-----|---|--|--|

50, 51, 52. Turn blouse right side out and measure only that portion that shows on the right side. Using the plastic ruler measure the length of two seams; then subtract the shorter from the longer.

52. Unfold hem if it has been turned up and measure as shown at "E".

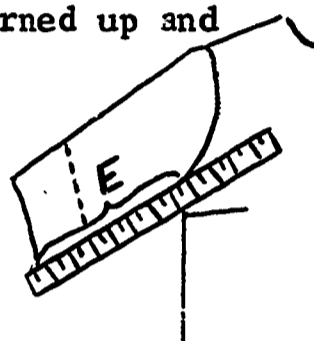

53. Use tape measure, starting at underarm sleeve seam intersection and pinning tape measure at starting point.

54. Run a colored basting thread through the lengthwise grain of the facing at center back and blouse.

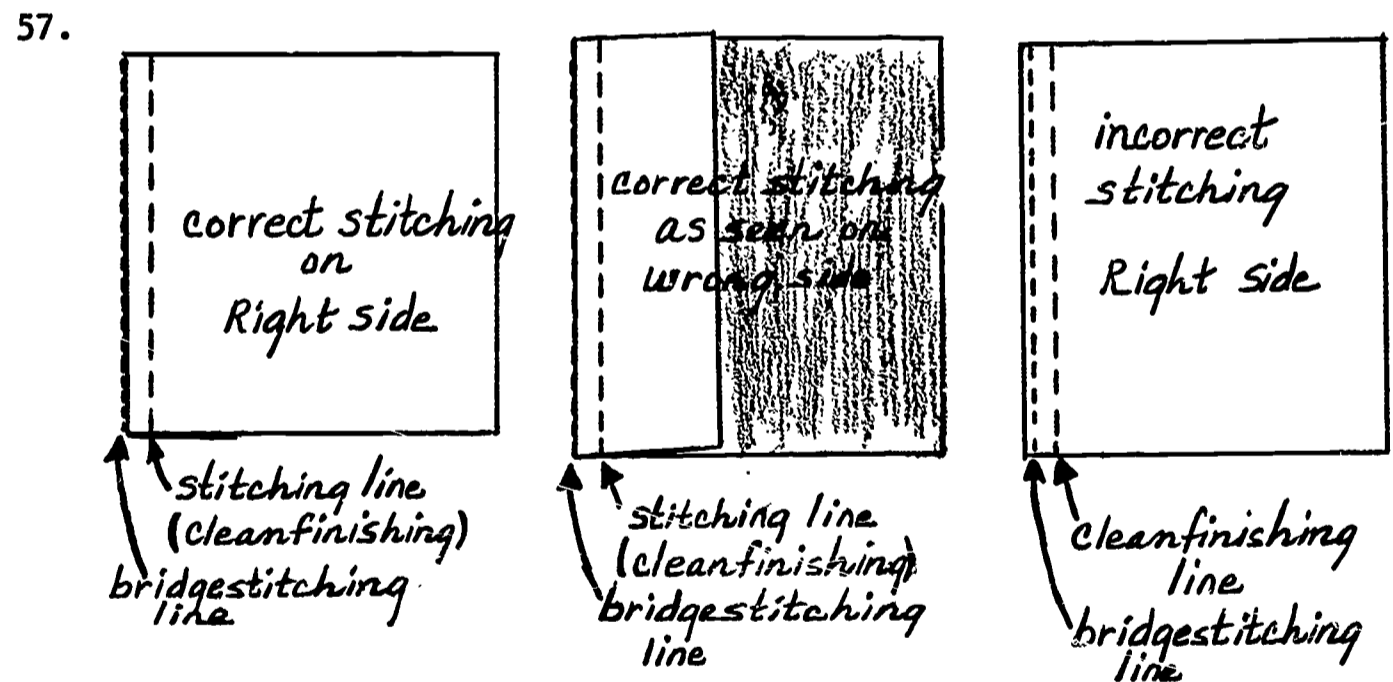

70. Approximating Right Angles

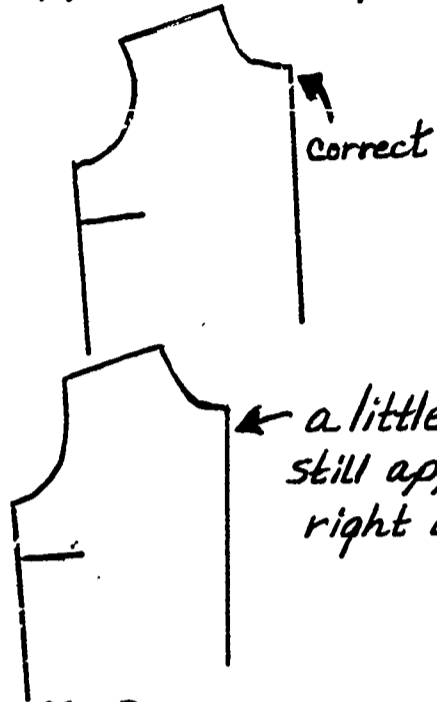

NOT Approximating Right Angles

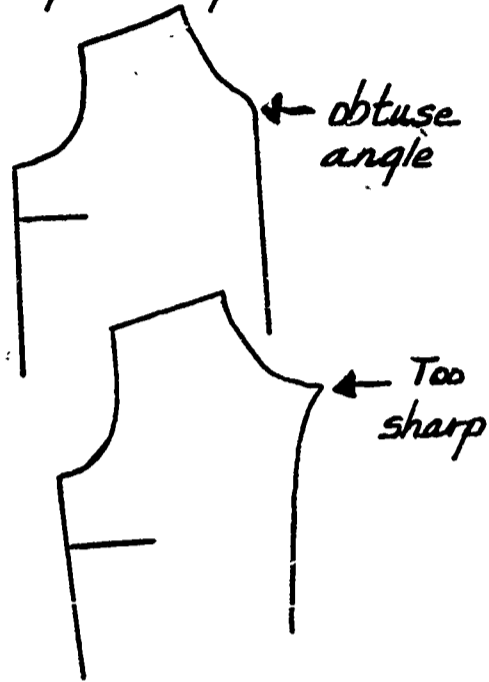

74, 80. PUCKERING

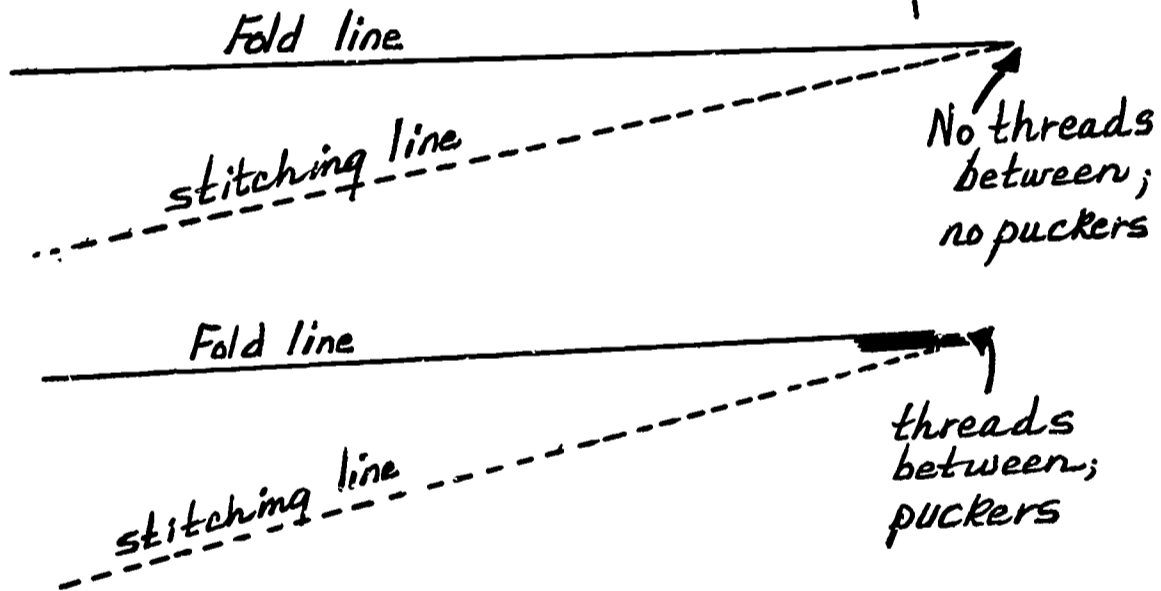

76, 82. TAPERING

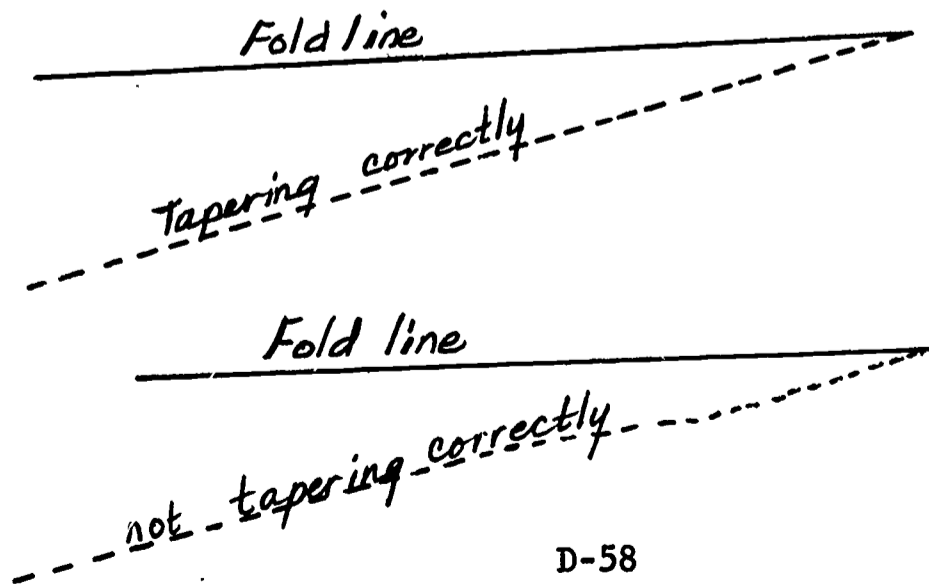

86. Evidence of neglect to press dart before crossing it with a seam.

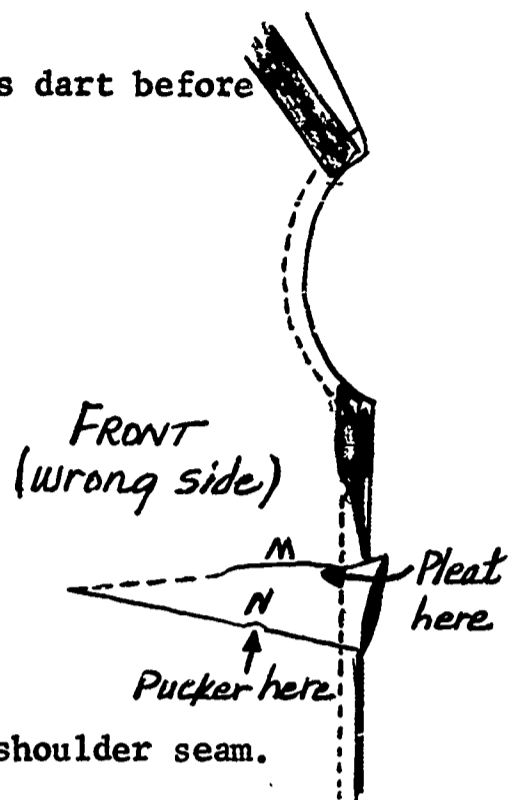

91. Marked line at "A" matches shoulder seam.



99, 100, 101. Clipped between the notches.

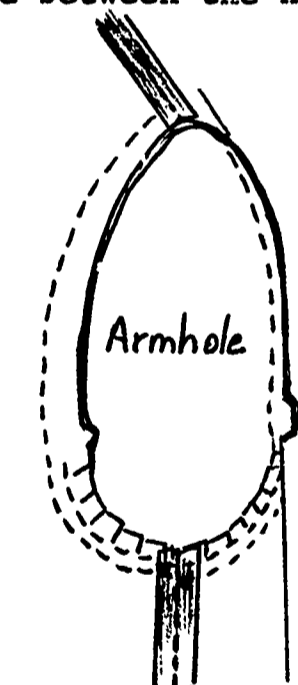

102, 103. Measure on wrong side of blouse. Hold ruler as diagramed, making sure that the zero line of the ruler coincides with the fold line.

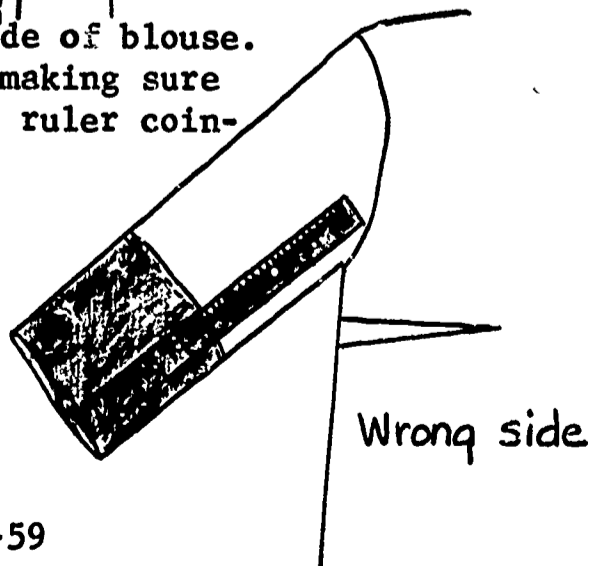

105.

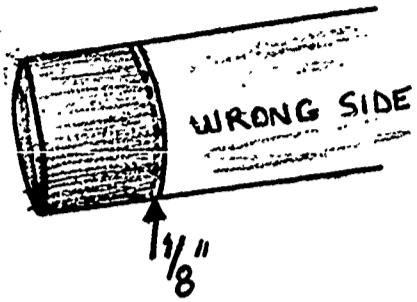

106.

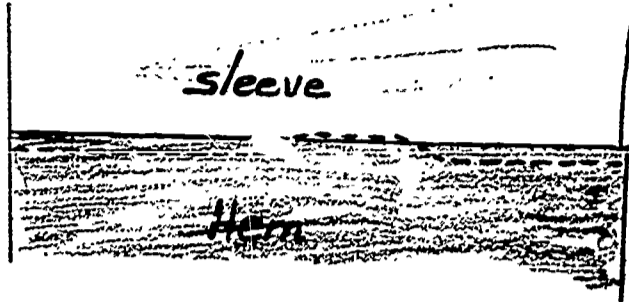

109. Turn front facing wrong side out to see if there is a bridgestitch line.

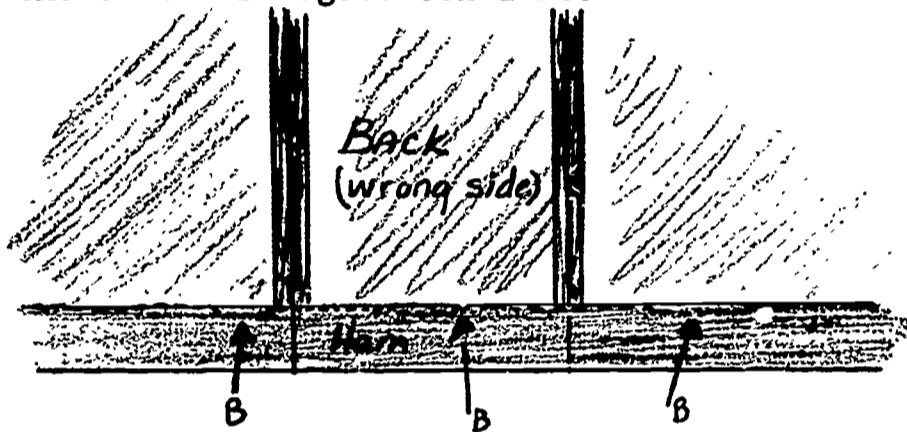

110. Hold against window pane to see this.

114. Subtract the width at the narrowest place from the width at the widest place.

116,, 117,, 118,, 119,, .

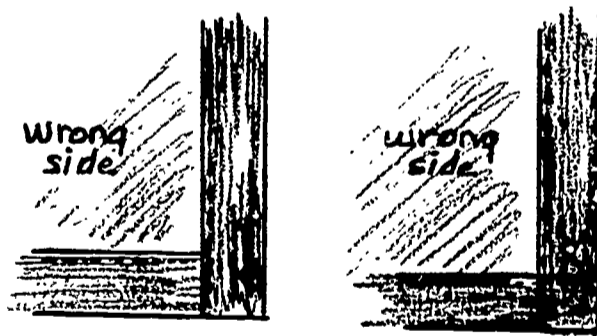

NAME _____ DATE _____

SCHOOL _____

SEWING EXPERIENCE

	YES	NO
1. Have you ever used a sewing machine?		
2. Do you have a sewing machine in your home?.....		
3. Did you use a sewing machine in a junior high school home economics class, in 4-H Club work, in Girl Scouts, or in projects in any other club?....		
4. Did your mother teach you how to use a sewing machine?.....		
5. Which of these garments have you made? Write the <u>number</u> of garments made in the appropriate column.		

<u>Garments</u>	<u>with help</u>	<u>without help</u>
apron.....		
sleeveless blouse.....		
blouse with sleeves.....		
gathered skirt.....		
fitted skirt.....		
shift or jumper.....		
dress with waistline seam.....		
two-piece outfit..... (skirt and jacket or top)		
shorts or slacks.....		
other: _____		

APPENDIX E

Diagram of Blouse Used in the Study



E-1

APPENDIX F

Information Sheet Given to Teachers

INFORMATION FOR TEACHERS

Sewing Machine

Information and skills covered in this section of the program:

- A. Location of parts of the machine and an understanding of their use
 - B. Ability to perform the following operations:
 - thread upper parts of the machine
 - wind bobbin
 - thread underneath parts of the machine
 - bring bobbin thread through hole in throat plate
 - begin and stop stitching with thread, fabric, and all parts in proper place
 - adjust tension
 - adjust length of stitches and use 12-15 for medium weight cotton
 - make varying widths of seams, using a guide
 - replace the needle
 - check sequence of threading, direction of threading needle, and threading of bobbin case before adjusting tension
- optional {
- remove presser foot and replace it with a zipper foot
 - turn a square corner with continuous stitching
 - back stitch by reversing the lever on the stitch-length regulator

The Pattern

Information covered in this section of the program:

- A. Body measurements
 - bust
 - waist
 - back waist length
- B. Selection of pattern corresponding to measurements and figure type for self and for other persons
- C. Identification of the following terms:
 - selvage
 - raw edge
 - lengthwise threads
 - crosswise threads
- D. Procedure for straightening fabric which can be used by a student working alone
- E. Information available on the pattern envelope

- F. Procedure for selecting fabric and notions
- G. Selection and use of layout diagrams
Pin grainline first when pinning pattern pieces to fabric.
- H. Identification of pattern markings
- I. Procedure for cutting
Cut notches outward.
- J. Procedure for marking
Tracing wheel and dressmaker's carbon paper are to be used.
(Do not use white carbon paper.)
The following should be marked: darts; center front and fold line at neckline and bottom edge for an inch; seam lines on the armhole, neckline, and sleeve cap; center of sleeve cap; and dots on sleeve and armhole.
The ends of darts are marked with a crossline.

Blouse Construction

Information and skills covered in this section of the program:

A. Staystitching and Bridgestitching

The following edges are staystitched:

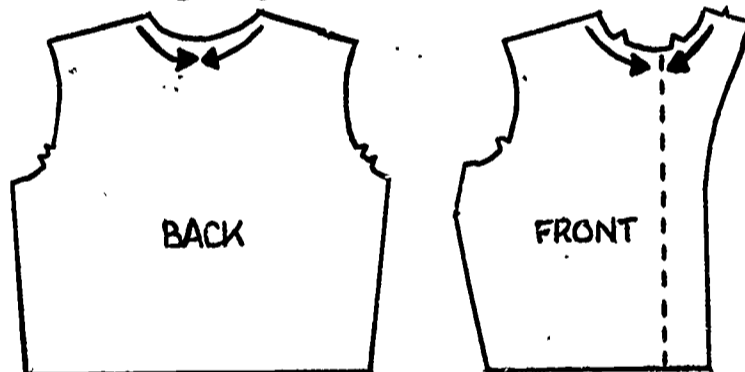

The line of staystitching is placed $1/8''$ from the marked seam line toward the cut edge.

The "kitty" test is used to determine direction in which to stitch.

Bridgestitching is a term used to refer to a line of stitching which is done to form a line on which to turn a hem on the free edges which will later be cleanfinished or hemmed.

Bridgestitching is done $1/4''$ from the edge on the following edges:

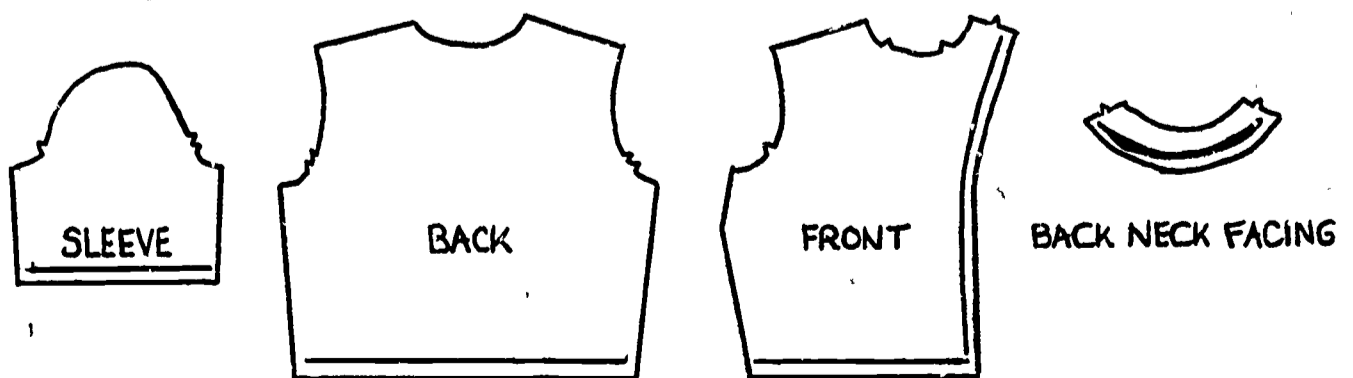

Staystitching and bridgestitching threads are trimmed, but not secured.

Staystitching and bridgestitching are done with 12-15 stitches per inch.

B. Darts

Darts will be pin basted before stitching, but not hand basted.

Pins are placed on the stitching line from the widest part toward the left hand.

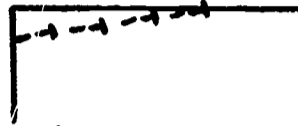

Threads at the narrow end of the dart are secured by tying the threads.

C. Plain Seams

Pins are placed at right angles to the seam line.

Threads are not secured.

Shoulder seams are slightly eased.

Notches are pinned first when pin basting a plain seam.

Shoulder, side and armhole seams are not trimmed.

D. Facings

Fitted facings are separate units and extended facings are cut in one piece with the outer garment section.

The seam formed when the back neck facing is stitched to the extended front facing at the shoulders is trimmed to 1/4".

The free edge of the facing is cleanfinished, that is--

a. pressed up on bridgestitch line, and

b. stitched about 1/8" from fold

(Free edge is term used to refer to outside edge of facing that is not caught in seam.)

The facing seam allowance is trimmed to 1/4" and clipped.

The facing is understitched to the seam allowance and threads are pulled to the wrong side.

The bottom corner is finished by folding and pin basting the extended front facing to the outside of the garment, right sides together, at the fold line.

Garment Front
(outside)

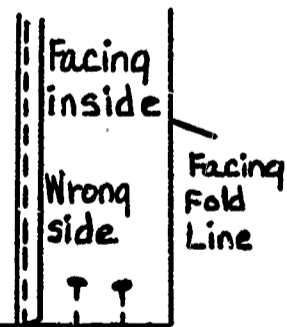

The facing is anchored only at the seams.

E. Sleeves

Two lines of ease threads (8-10 stitches per inch) are used, one on the seam line and one 1/4" from the seam line,

(toward the cut edge). The lines of stitching begin and end at the notches.

Method of inserting the sleeve:

Stitch the sleeve seams and blouse side seams and then stitch the sleeve to the armhole opening.

The armhole seam is finished by stitching the seam allowance together $\frac{1}{4}$ " from the seamline between the notches and clipping to this line of stitching.

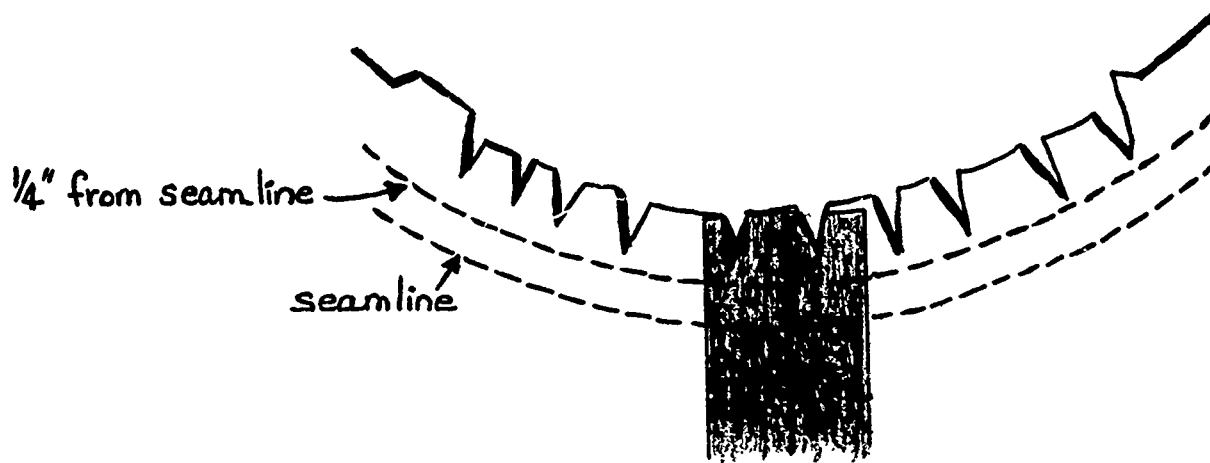

F. Hems

The following process is used for hemming the blouse:

- press crease on the bridgestitch line and cleanfinish
- press the hem up on the hemline
- pinbaste with the pins perpendicular to the edge
- stitch and secure threads by hand knots

The sleeve hem is machine stitched after the sleeve is set in. The threads are secured by stitching 1" past the starting point.