

R E P O R T R E S U M E S

ED 020 639

EF 001 785

MUSIC BUILDINGS, ROOMS AND EQUIPMENT.

BY- GRAY, CHARLES L.

MUSIC EDUCATORS NATIONAL CONFERENCE, WASH., D.C.

PUB DATE 66

EDRS PRICE MF-\$0.50 HC NOT AVAILABLE FROM EDRS. 125P.

DESCRIPTORS- *MUSIC ACTIVITIES, *MUSIC EQUIPMENT, *MUSIC FACILITIES, *PHYSICAL DESIGN NEEDS, *SCHOOL PLANNING, ACOUSTICS, AUDITORIUMS, EQUIPMENT, FACILITY GUIDELINES, HEATING, SPATIAL RELATIONSHIP, VENTILATION,

MUSIC FACILITY GUIDELINES WERE DEVELOPED FOR THE MUSIC EDUCATOR, ADMINISTRATOR, BOARD OF EDUCATION AND THE ARCHITECT IN DESIGNING AND CONSTRUCTING NEW OR REMODELING EXISTING SCHOOL BUILDINGS. SUBJECT AREA COVERAGE INCLUDES MUSIC FACILITIES AT ALL LEVELS FROM THE ELEMENTARY SCHOOL THROUGH THE UNIVERSITY. THE CONTENTS ARE DIVIDED INTO THE FOLLOWING AREAS--(1) THE NEED FOR MUSIC FACILITIES, (2) PLANNING MUSIC FACILITIES, (3) LOCATION OF MUSIC FACILITIES, (4) ROOM AND AREA REQUIREMENTS, (5) THE AUDITORIUM, (6) TECHNICAL CONSIDERATIONS--ACOUSTICS, HEATING AND VENTILATING, ILLUMINATION, COLOR ELECTRICAL INSTALLATIONS, (7) EQUIPMENT, INSTRUMENTS, AND FURNITURE, AND (8) CASE STUDY--BUILDING A COLLEGE MUSIC BUILDING. A TYPICAL SPECIFICATION SHEET AND BIBLIOGRAPHY ARE ALSO INCLUDED. THIS DOCUMENT IS AVAILABLE FOR \$4.50 FROM THE MUSIC EDUCATORS NATIONAL CONFERENCE, 1201 SIXTEENTH STREET, N.W., WASHINGTON, D.C. 20036. (RH)

PROCESS WITH MICROFICHE AND
PUBLISHER'S PRICES. MICRO-
FICHE REPRODUCTION ONLY.

ED020639

MUSIC BUILDINGS, ROOMS AND EQUIPMENT

Permission to reproduce this copyrighted work has been granted to the Educational Resources Information Center (ERIC) and to the organization operating under contract with the Office to Education to reproduce documents included in the ERIC system by means of microfiche only, but this right is not conferred to any users of the microfiche received from the ERIC Document Reproduction Service. Further reproduction of any part requires permission of the copyright owner.

PROCESS WITH MICROFICHE AND
PUBLISHER'S PRICES. MICRO-
FICHE REPRODUCTION ONLY.

MUSIC BUILDINGS, ROOMS AND EQUIPMENT

Prepared by a Committee of the Music Educators National Conference

HOMER ULRICH, Chairman

Edited by CHARLES L. GARY

MUSIC EDUCATORS NATIONAL CONFERENCE
1201 Sixteenth Street, N.W., Washington, D. C. 20036

Copyright 1966
by the
Music Educators National Conference
Library of Congress Catalog Number 55-3617

"PERMISSION TO REPRODUCE THIS COPYRIGHTED
MATERIAL BY MICROFICHE ONLY HAS BEEN GRANTED
BY Music Educators Natl. Conference (MENC)
TO ERIC AND ORGANIZATIONS OPERATING UNDER
AGREEMENTS WITH THE U. S. OFFICE OF EDUCATION.
FURTHER REPRODUCTION OUTSIDE THE ERIC SYSTEM
REQUIRES PERMISSION OF THE COPYRIGHT OWNER."

Printed in U.S.A.
Price \$4.50

MENC COMMITTEE ON MUSIC BUILDINGS, ROOMS, AND EQUIPMENT

Homer Ulrich, Chairman
University of Maryland, College Park

Joseph Blankenship
University of New Mexico, Albuquerque

C. Herbert Duncan
Normandy School District
St. Louis, Missouri

Robert J. Fraser
Wayland (Massachusetts) High School

Charles L. Gary
Music Educators National Conference
Washington, D. C.

Paul R. Lehman
University of Kentucky, Lexington

Nelson Patrick
University of Texas, Austin

Herbert Shive
Indiana University, Bloomington

Gerald Strang
San Fernando State College
Northridge, California

CONTRIBUTING CONSULTANTS

C. Harold Barcus
Associate Professor of Architecture
Miami University, Oxford, Ohio

Samuel E. Homsey
Architect, Wilmington, Delaware

Robert B. Newman
Bolt, Beranek and Newman, Inc.
Cambridge, Massachusetts

COVER: *Robertson Hall*
Oberlin College Conservatory of Music

Preface

This is the fifth edition of *Music Buildings, Rooms and Equipment*, the first having appeared as Bulletin 17 of the Music Education Research Council in 1932. Joseph E. Maddy was chairman of the committee which prepared this first edition. A minor revision was issued in 1938 and a completely revised and enlarged edition was prepared by Clarence J. Best in 1949. The fourth edition (1955) was the work of a large and active group of MENC members and friends working under the direction of Elwyn Carter. The initial planning for the present volume was made in 1963 with Elwyn Carter again serving as chairman. When it became impossible for him to continue in this capacity, Homer Ulrich, who was in the midst of his own building program, graciously accepted the assignment for the Conference. The thanks of all the profession are due to him and to all who worked on this book which promises to be as helpful as its predecessors.

In addition to the members of the committee, many others deserve thanks for their assistance in gathering the photographs and plans that contribute so much to a book of this type. Among these, special recognition is due Joseph T. Adgate, Earl E. Beach, Roger Jacobi, Christopher Jaffee, Robert Krueger, Walter E. Reeves, and Harry Wenger. The Conference is grateful for the cooperation of school systems, colleges, and architectural firms. Recognition is also made for the help of the following:

American Association of School Administrators
Bolt, Beranek and Newman, Inc., Cambridge, Massachusetts
Century Lighting, Inc., New York
Consolidated Equipment Company
Hub Electric Company, Inc., Chicago
Mutschler Brothers Company, Nappanee, Indiana
Norren Manufacturing Company, Arcadia, California
E. H. Sheldon Equipment Company, Muskegon, Michigan
Stagecraft Corporation, Norwalk, Connecticut
3M Company, Saint Paul, Minnesota
Tiffen Scenic Studios, Inc., Tiffen, Ohio
Wenger Corporation, Owatonna, Minnesota
The Wurlitzer Company, DeKalb, Illinois

A special word of thanks is due Elizabeth Greene, not only for her assistance with the many details connected with such an undertaking, but for the contribution of her artistic talents to many phases of the project.

Charles L. Gary

Table of Contents

Chapter		Page
I	The Need for Music Facilities	1
II	Planning Music Facilities	6
III	Location of Music Facilities	13
IV	Room and Area Requirements	24
	Instructional Areas	27
	Auxiliary Areas	41
V	The Auditorium	47
VI	Technical Considerations	64
	Acoustics	64
	Heating and Ventilating	77
	Illumination	78
	Color	83
	Electrical Installations	88
VII	Equipment	89
	Instruments	89
	Furniture	99
VIII	Case Study: Building a College Music Building	104
	Bibliography	113
	Index	118

CHAPTER I

The Need for Music Facilities

IN THE MOST RECENT YEAR for which figures are available, 80 percent of the new secondary school buildings and 26 percent of the new elementary buildings completed in the United States contained special facilities for music.¹ Music facilities were included in more new secondary schools than were cafeterias, language laboratories, art rooms, commercial rooms, shops, gymnasiums, home economics rooms, or auditoriums; only science laboratories, and libraries, were found in a larger percentage of schools. These figures reflect widespread public support at the local level for the music education program. On the other hand, however, such statistics reveal that even at the secondary level approximately one new school in five contains no special facilities for music. The proportion of older buildings lacking music facilities would very likely be considerably higher. In view of the specialized nature of music activities, especially at the secondary level, it is difficult to visualize how the complete music program essential in today's schools can be carried on unless the necessary means are provided.

Before there can be effective planning in school construction, there must be a general consensus as to the basic philosophy underlying the educational program in the community and the nature and extent of the curriculum that arises from that philosophy. There can be no single solution or set of solutions that will prove ideal in every situation. A physical plant will be successful in meeting the needs of a given school only when it is designed in terms of the particular educational philosophy of the community and when it provides sufficient flexibility to accommodate reasonable modifications in that philosophy. The necessity for a strong, balanced music program must be demonstrated logically and convincingly by the music educator. When this is done he will have far fewer difficulties in securing the facilities he wants and needs to carry on that program.

Music Buildings, Rooms and Equipment is intended to provide guidelines for the music educator, the administrator, the board of education, and the architect in designing and constructing new school buildings or remodeling existing ones. It is broad in scope; it deals with music facilities at all levels from the elementary

school through the university. It is concerned with the location, design, and size of the facilities; with the storage and auxiliary space provided; and with the equipment that is placed in those facilities. It is also concerned with auditoriums and music shells. In addition, it contains sample floor plans and photographs of recently completed music facilities, as well as a bibliography of additional references.

The specific purposes of this publication include the following:

1. To guide the thinking of the music educator with regard to the physical requirements necessary for the successful performance of his duties.
2. To further acquaint the administrator and architect with some of the specialized departmental needs with which they may have been familiar only in general terms.
3. To suggest proven, satisfactory solutions to some of the problems which commonly arise in the design and construction of new music facilities.
4. To serve as a checklist of details to be considered in planning and furnishing the facilities so that the music instructor does not realize too late that his music room is improperly located, contains inadequate storage areas, or is encumbered by other serious flaws that could have been corrected if brought to the attention of the proper authorities in time.

The music educator should be given an important voice in the designing of the music facilities. It is particularly essential that he be consulted early in the planning stages and that his opinions be sought periodically thereafter. As the specialist who will actually be using the space and equipment provided, he is in a position to offer valuable practical advice. The board of education and the architect have an obligation to consider very seriously the suggestions that are contributed by all of the professional staff.

Essential as it is that the architect and the administrator be aware of the needs and problems of the music educator, it is equally important that the music educator be aware of the needs and problems of the architect and administrator. The teacher need not hesitate to ask for the equipment and facilities that are necessary to the satisfactory performance of his duties, but he must be realistic in his requests and he must be able to justify them in terms of the philosophy of the school. Further, he must understand that the board of education, which

¹ "Current Trends in School Facilities," *School Management*, X, 7 (July 1966), 75.

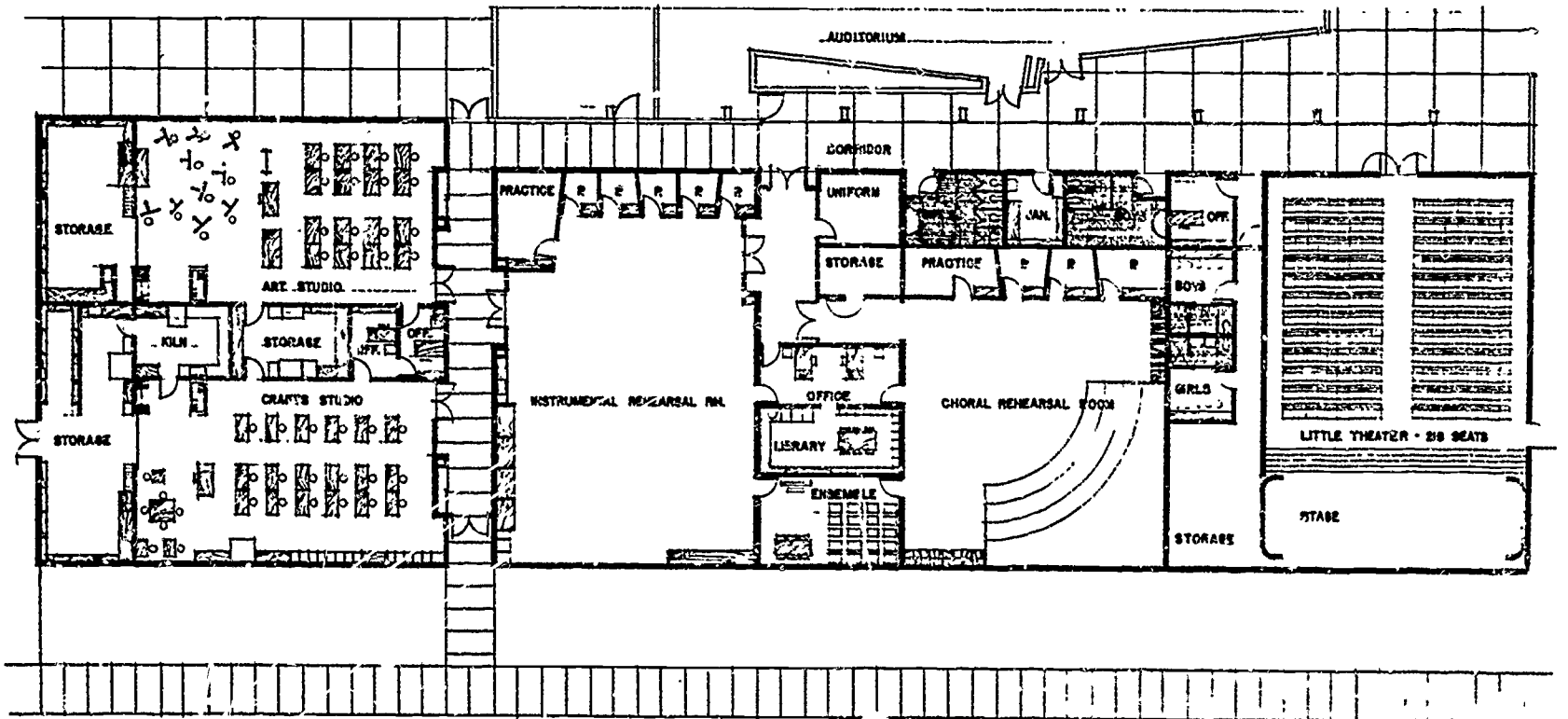
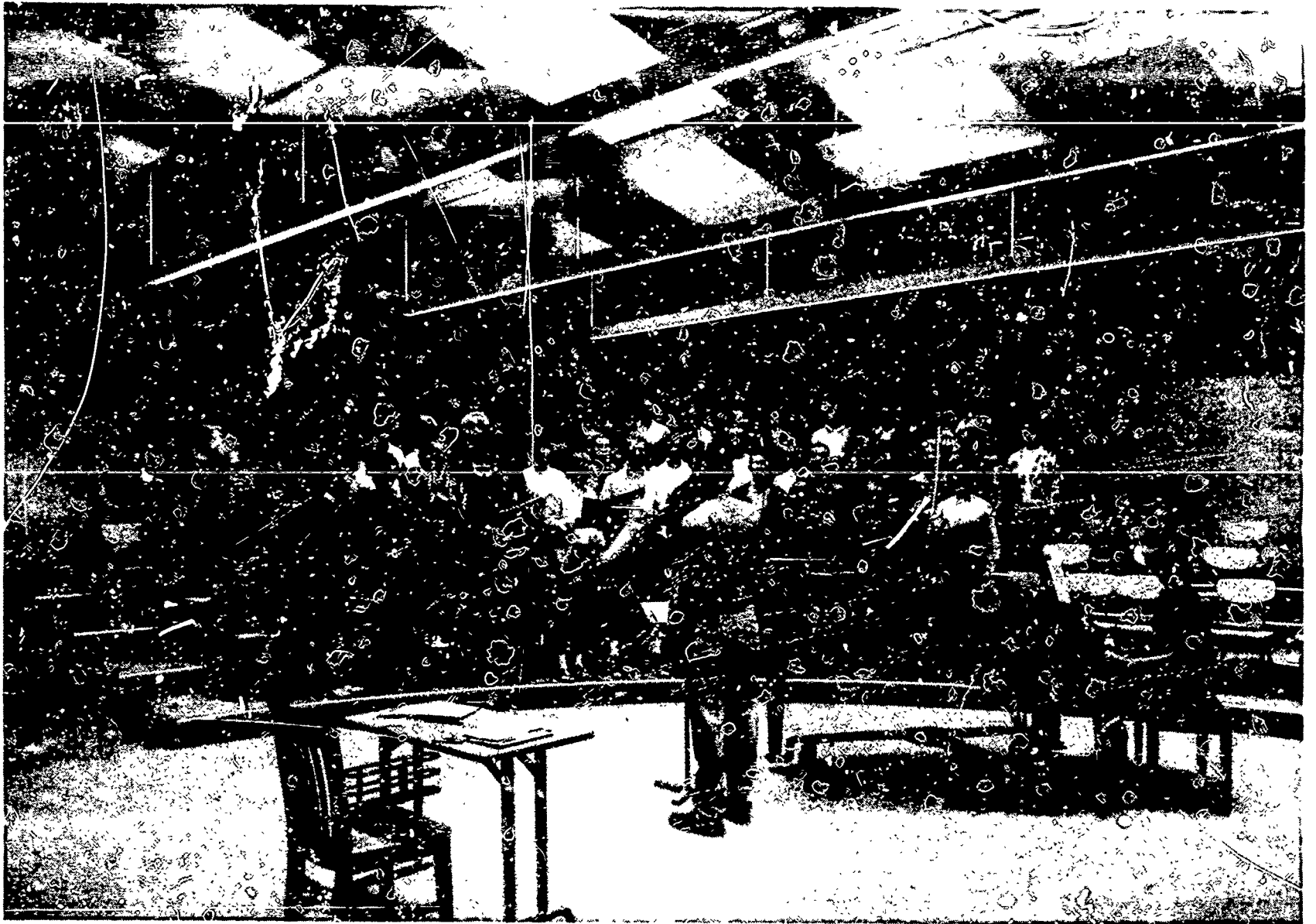

The specialized nature of music activities requires appropriate facilities necessary.
Henry D. Sheldon High School, Eugene, Oregon
Lutes and Amundson, Architects



It is important to provide for the full use of new instructional media.
 Listening Center
 University of New Mexico, Albuquerque

is subject to pressures from many sources, must reconcile the divergent interests of the various parties, including the taxpayer.

The music educator and the administrator share the responsibility for making certain that the facilities are adequate for the future needs of the school. Not only must increases in student and faculty personnel be anticipated, but contemplated changes in the nature or scope of the music curriculum must also be considered. It behooves the music educator faced with the prospect of a new building to be more concerned with the latest developments in his own profession than with new building techniques, in order that he may best assist the architect in planning for the future. In addition, it is

important to provide for the full use of the various instructional media, which are rapidly becoming more numerous and more sophisticated. These aids promise far greater efficiency and flexibility in teaching than has been possible previously. Their potential should not be neglected.

During the preliminary discussions the music teacher should arrange to visit the music facilities of new schools nearby and talk with the teachers who have used the facilities to find out what features they like and what features they do not like. Occasionally there is some discrepancy between the theoretical usefulness of a given feature and its actual utilitarian value in the classroom. However, the teacher should also be concerned with

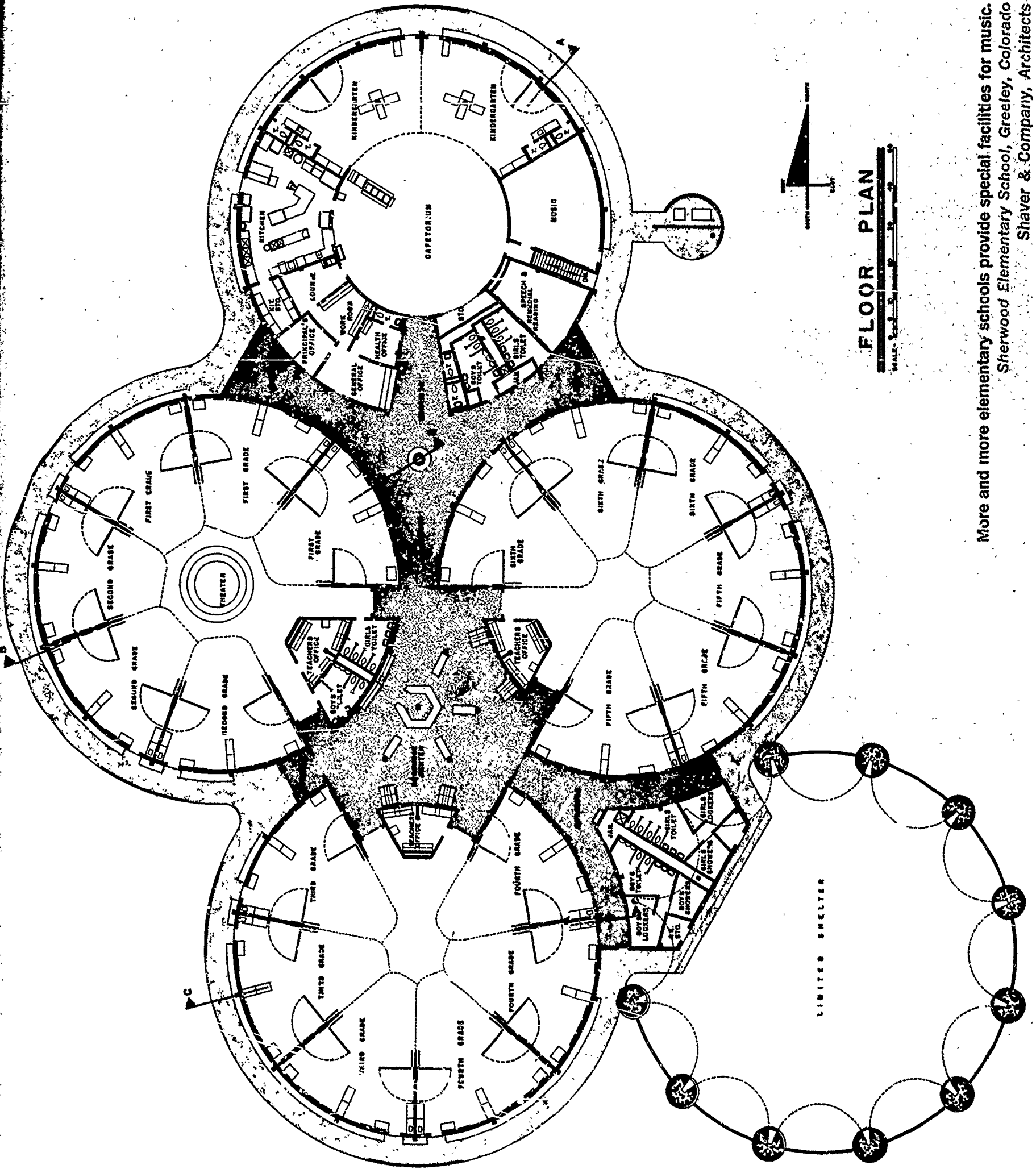

FLOOR PLAN

More and more elementary schools provide special facilities for music.
Sherwood Elementary School, Greeley, Colorado
Shaver & Company, Architects

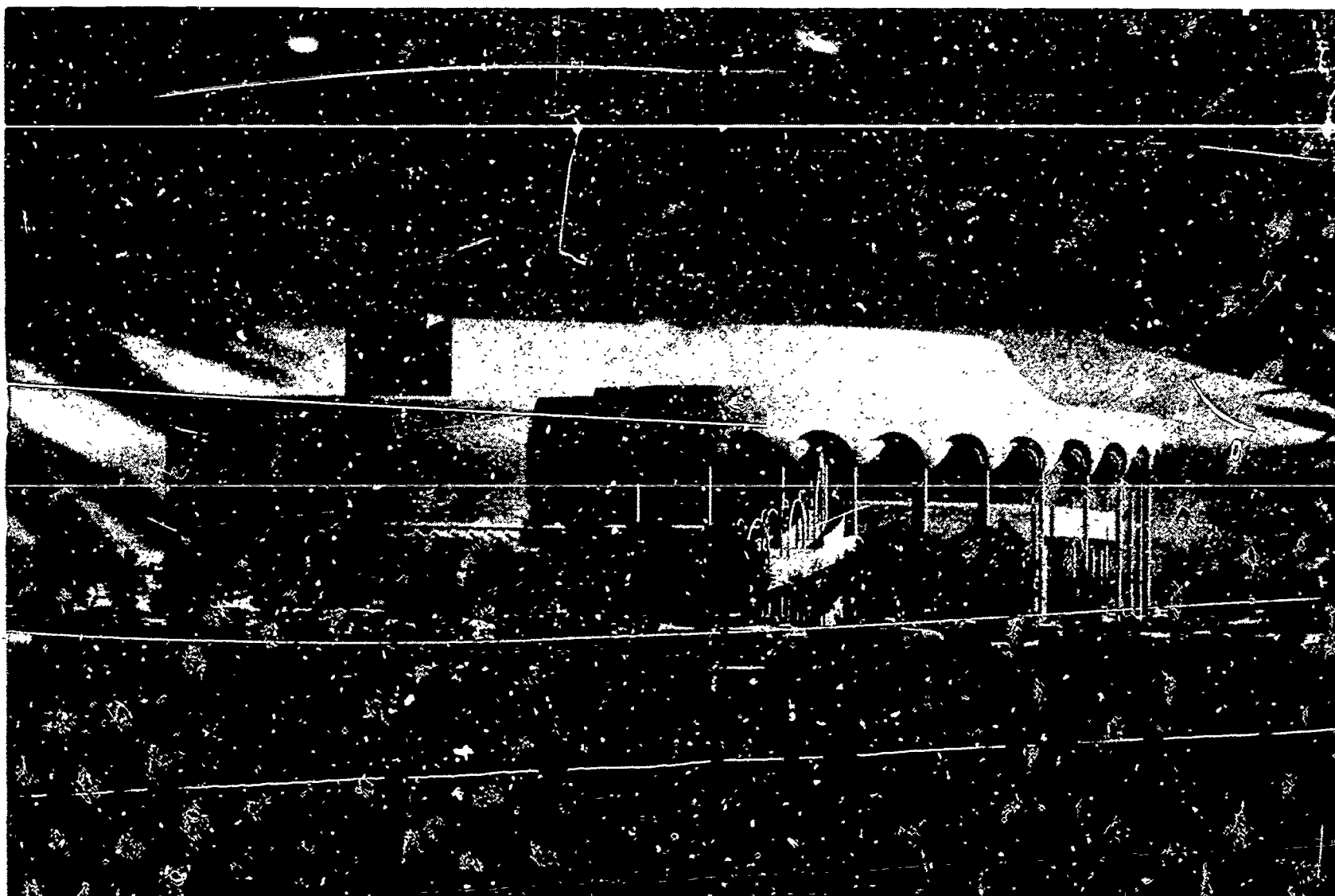

Widespread public support for music and the performing arts is becoming increasingly evident.

Grady Gammage Memorial Auditorium
Arizona State University, Tempe
Designed by Frank Lloyd Wright

the reasons for his colleagues' preferences because some of those reasons may not be applicable in his own circumstances.

Music Buildings, Rooms and Equipment can be used in the following ways:

1. The music educator may familiarize himself with this material before preliminary discussions are begun in order that he may be more knowledgeable and better able to discuss the problems intelligently.

2. He may study in greater detail questions or issues that are unfamiliar to him by consulting appropriate works from the bibliography and other materials cited by those works.

3. He may make this publication available to the superintendent, the architect, the board of education, and

other responsible persons. He may also make available whatever additional material may be necessary to substantiate his views and document his requests.

4. He may review pertinent sections of this publication as the planning and construction progress. He should be certain that he is informed of any changes that are made in the plans and he should be as closely involved as possible at all stages.

5. He may utilize the material contained here not only in the construction of new facilities but also in the refurbishing of existing facilities.

The committee that has prepared this book is composed of music educators and technical consultants. They hope that their work will be of value to the music educator faced with the happy prospect of new facilities.

Planning Music Facilities

THE PLANNING of a building designed for music teaching must be a cooperative activity. Music departments and music schools differ widely in the proportionate amount of attention they devote to the several types of instruction—classes, private lessons, ensemble rehearsals, for example—and no architect can plan intelligently unless he is made aware of the particular needs of his client. As a first step in planning, therefore, the types of instructional program must be outlined for the architect. This can best be done by those active in the program, the music faculty. Coordination and refinement of the ideas expressed by the faculty can later be supplied by some central authority.

Teachers will be most helpful to their principal, superintendent, and architect if they resist the temptation to plan their own facilities. What the architect will appreciate most is not a sketch, though these can sometimes be helpful, but the answers to several basic questions.

What are you going to do? The architect, like most laymen, does not know what music educators want to do in their facilities. He needs to be told directly the

nature of your intended activities such as: rehearse a band, teach a general music class, coach an ensemble, instruct a beginning string class, show a film, or give a private lesson.

How many pupils are involved? In addition to the expected enrollment of each class or performing group, of each teacher in the department, the architect will need to be told the anticipated growth for the next five to ten years. In the case of some classes or organizations he may want to know the maximum effective size of such a group.

How does this activity fit into the total school program? A good building is planned for the program it is to house and music teachers should remember their responsibility to the whole school. Thus they need to think of the need for a large assembly area where music organizations can be used to instruct the other students as well as for rehearsal rooms.¹ They may also need to remember that sharing music rooms with other classes may make it

¹ Karl D. Erast and Charles L. Cary, editors. *Music in General Education*. Washington: Music Educators National Conference, 1965, p. 10-11.

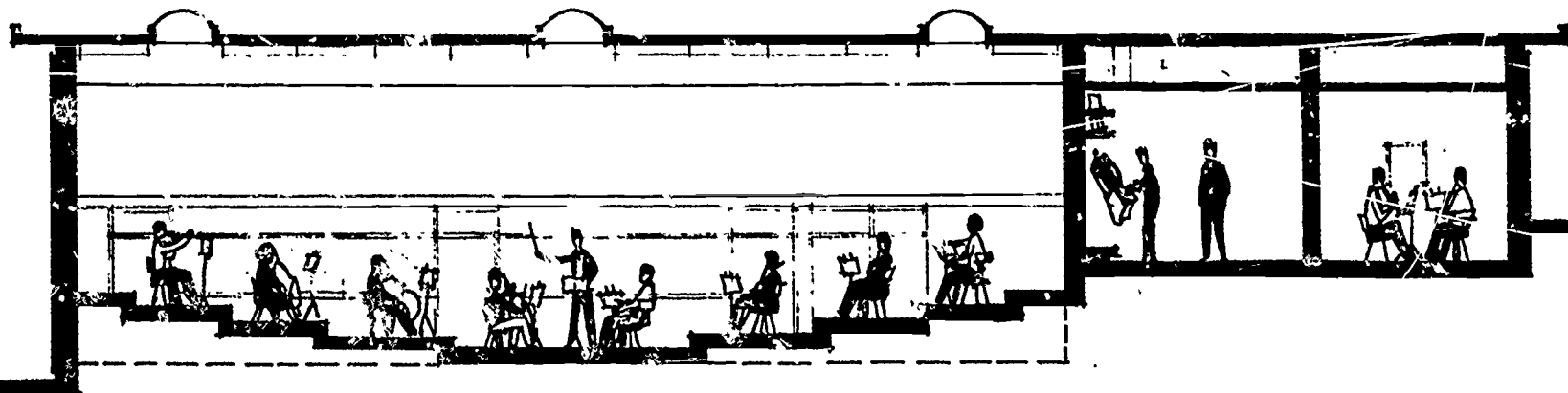

SECTION THRU MUSIC BUILDING - NEWARK HIGH SCHOOL

A teacher can best help the architect by describing what he plans to do and how many pupils will be involved.
Newark (Ohio) High School
Perkins & Will, Architects

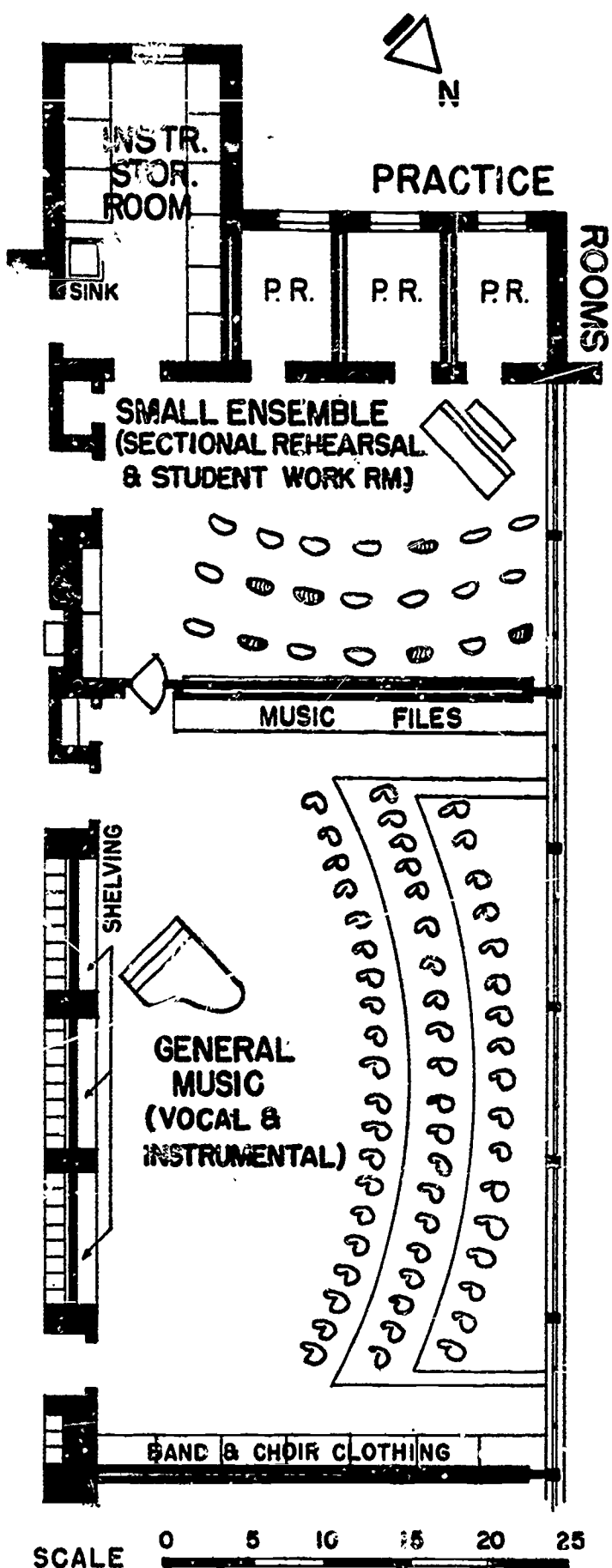

Some schools may employ only one music specialist to do both the vocal and instrumental music teaching.
 Northeast Junior High School
 Kalamazoo, Michigan

possible to build with more quality of construction.

Experience has shown that planning done under the pressure of time is likely to be faulty, incomplete, or uneconomical. It is highly desirable to provide as much "lead time" as possible, so that faculty members' ideas can be reviewed and assimilated before they are presented to the architect.

Because of the nature of the learning experiences in music, proper planning must have acoustics in mind from the very beginning. In the early stages of gathering ideas, it is well to determine needs in each of the major areas: classrooms, private studios, practice rooms, large rehearsal rooms, concert facility, offices, theory and listening laboratories, library, and storage areas. At this stage it is probably desirable to anticipate future needs rather liberally, in line with the institution's own projected enrollment figures. Yet it must be borne in mind that in most cases the school is under pressure from other departments to provide them with additional space also. It may not always be possible to meet fully even well-documented needs in a music facility. On the other hand, no building committee should eliminate facilities which are necessary for the functioning of the school's well-planned music program.

It has often been found useful to assign the planning of each major area to an individual or faculty group, in order to guard against the omission of desirable features. A central committee or the department chairman may then be charged with coordinating these several requests, examining them carefully for needless duplication, and finally preparing the composite request for submission to the physical plant administrator or the architect.

The size of the school or of the community is not always an adequate indication of the size of the music department or of its requirements in facilities. Schools in some small communities and some small collegiate institutions may employ a large music staff and may offer both an extensive and intensive music program. Other schools may employ only one music specialist to do both the vocal and instrumental teaching. The institution's basic philosophy as it affects music education will have an important influence on the ultimate decisions made about music facilities. Once the nature of the program has been established, a primary factor in determining music department needs becomes the number of teachers employed by the school to take care of the music activities. This is a more significant number than school enrollment or area population.

Where the new building is to be a replacement, the number and size of the classrooms can be estimated by

beginning with the existing facility. Allowances will be made for desirable changes if existing rooms are too small or too large, and for estimated needed additions. Projected changes in the department's program or method of operation such as small lecture sections being replaced by a large section or a related arts course being added to the department's program will need to be considered. Demands which may be made on the classrooms by departments other than music must not be overlooked.

In situations in which a new school is being added to a system, or a new program developed in a college, it is advisable to visit existing schools with comparable curricular offerings and enrollment in order to establish a base from which to make plans. In the interest of economy, it will be necessary to consider whether the large ensemble rooms or the recital hall can be used as a classroom for part of the day, or whether teaching studios and small ensemble practice rooms can also serve small classes or seminars.

Just as it is essential to answer certain questions with respect to educational purposes before making decisions related to instructional areas, so is it important to inquire about traffic patterns as they will affect the function of auxiliary areas. Questions such as the following should be asked:

1. Do we want the student to pass through the instrument storage room to check out his instrument before each rehearsal?
2. Are rehearsal folios picked up and returned to the music library at each rehearsal?
3. Will students need to get their instruments or folios from storage areas while another rehearsal is in progress?
4. Are uniforms and equipment distributed to the student out of the storage rooms, or is the area used only for dead storage during the summer?

Answers to these and similar questions will influence the planning of such details of the auxiliary areas as

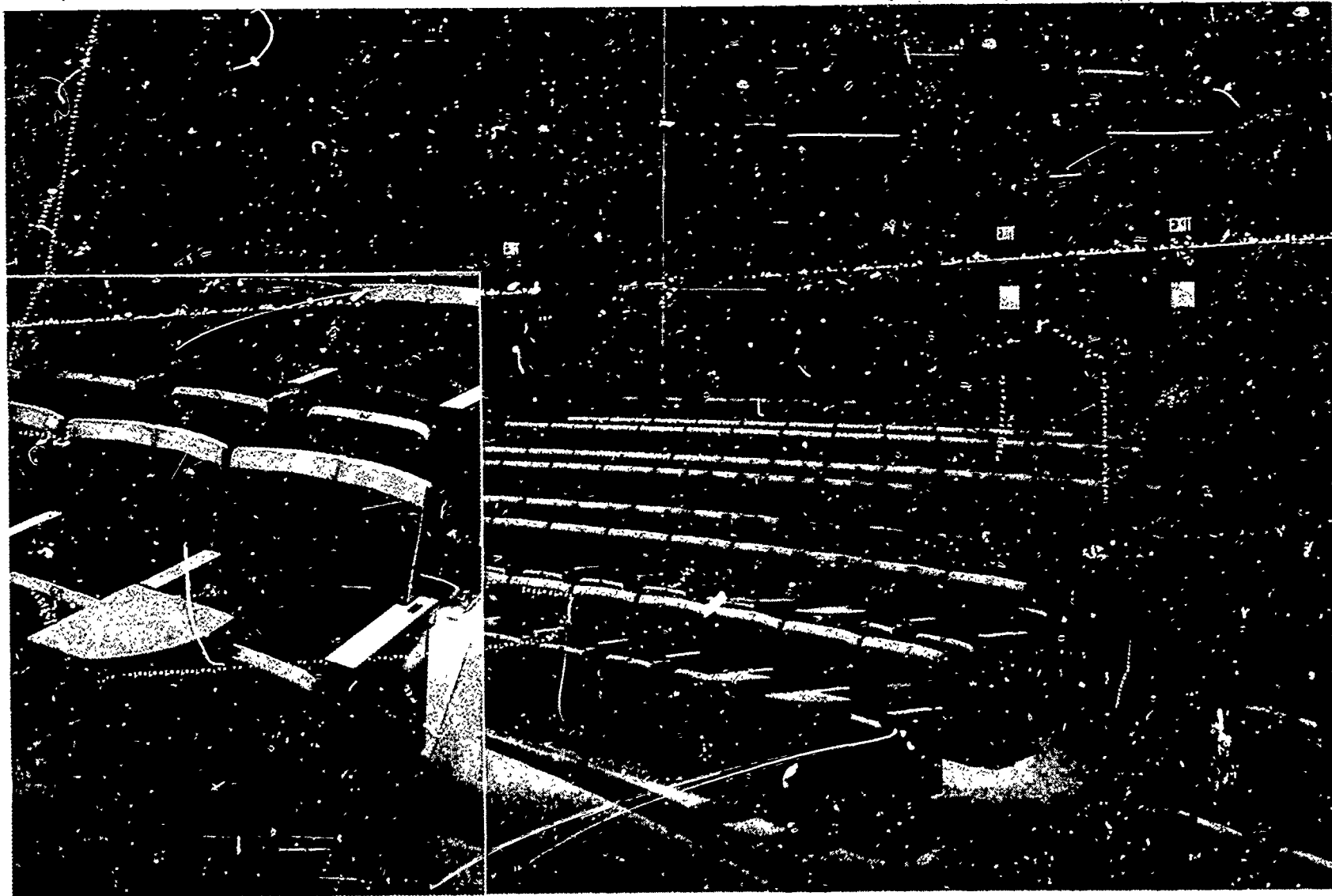

Recital halls may be used as classrooms for part of the day when equipped with tablet armchairs.
Tawes Fine Arts Center, University of Maryland, College Park
Henry Powell Hopkins and Associates, Architects

PART FIRST FLOOR - SHOPS, MUSIC & DRESSING ROOMS LAYOUT

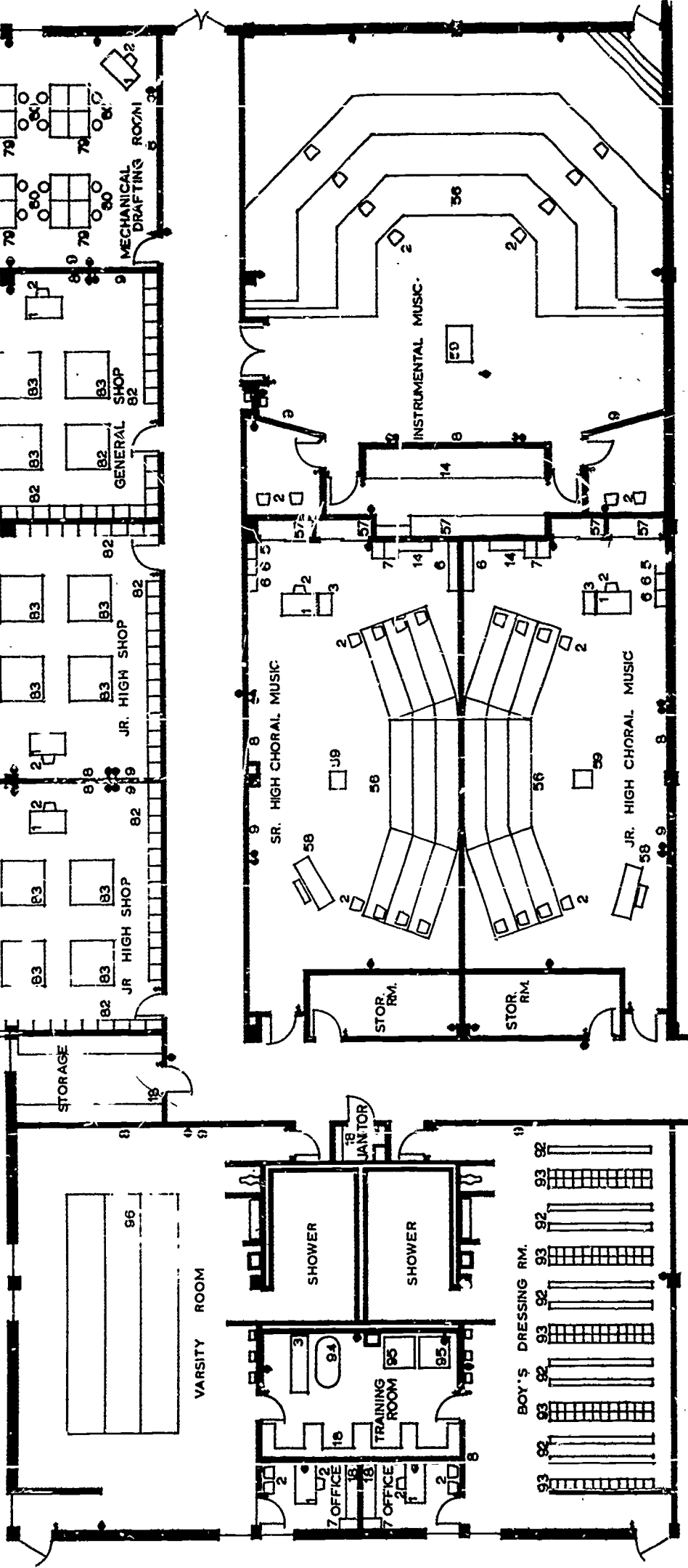
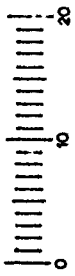

- EQUIPMENT LEGEND**
- 1 TEACHER'S DESK
 - 2 TABLE CHAIR
 - 3 TABLE
 - 4 TEACHER'S DESK
 - 5 TEACHER'S DESK
 - 6 GLOCK CASE
 - 7 GLOCK CASE
 - 8 CHALK BOARD
 - 9 CHALK BOARD
 - 10 UNIT VENTILATOR
 - 11 INSTRUCTOR'S TABLE
 - 12 WORK COUNTER
 - 13 DISPLAY CASE
 - 14 STORAGE CABINET
 - 15 ART WORKBENCH
 - 16 PAPER STORAGE CAB.
 - 17 POTTER'S WHEEL
 - 18 METAL SHAVING CAB.
 - 19 MOVABLE GLASS CART
 - 20 METAL EASEL
 - 21 SINK CABINET
 - 22 SINK
 - 23 KILN TABLE
 - 24 ART CABINETS
 - 25 ART CABINETS
 - 26 SUPPLY CABINETS
 - 27 REFRIGERATOR
 - 28 RANGE
 - 29 WASHER
 - 30 DRYER
 - 31 SINK
 - 32 BED
 - 33 WARDROBE
 - 34 PRESSER BOARD CAB.
 - 35 FINISHING TABLE
 - 36 MOUNTING TABLE
 - 37 SEWING MACHINE CHAIR
 - 38 SEWING MACHINE
 - 39 MIRROR
 - 40 MIRROR
 - 41 CUTTING TABLES
 - 42 CHECK OUT COUNTER
 - 43 CROOK STACKS
 - 44 LIBRARY TABLE
 - 45 SWIVEL CHAIR
 - 46 SECRETARY'S DESK
 - 47 SECRETARY'S CHAIR
 - 48 BOOK TRUCK
 - 49 CARD CATALOG
 - 50 MAGAZINE RACKS
 - 51 JOURNAL RACK
 - 52 JOURNAL RACK
 - 53 NEWSPAPER RACK
 - 54 BOOK CARTS
 - 55 REFERENCE UNITS
 - 56 REFERENCE UNITS
 - 57 REFERENCE UNITS
 - 58 PIANO STORAGE
 - 59 CONDUCTOR'S PLATFORM
 - 60 DESK
 - 61 ARM CHAIR
 - 62 CABINET
 - 63 COT
 - 64 MEDICINE CABINET
 - 65 SMALL BOXES
 - 66 CENTER
 - 67 MOVABLE CART
 - 68 KARDEX
 - 69 KARDEX
 - 70 CORE MACHINE
 - 71 COFFEE MACHINE
 - 72 CORRIDOR LOCKERS
 - 73 STUDENT CHEMISTRY TAB.
 - 74 FUME HOOD
 - 75 STUDENT PHYSICS TABLE
 - 76 STUDENT BIOLOGY TABLE
 - 77 TELEVISION SET
 - 78 SPEAKER PLATFORM
 - 79 DRAFTING TABLE
 - 80 STOOL
 - 81 BLUE PRINT MACHINE
 - 82 WORKBENCH
 - 83 WORKBENCH
 - 84 METAL TABLE
 - 85 METAL TABLE
 - 86 METAL WORK BENCH
 - 87 DRILL
 - 88 DRILL
 - 89 GRINDER
 - 90 SAW
 - 91 WASH STAND
 - 92 BENCH
 - 93 BASKET LOCKERS
 - 94 WHIRLPOOL BATH
 - 95 25 LB WASHER-DRYER
 - 96 OVERHEAD HANGING ROD

JEFFERSON COUNTY BOARD OF EDUCATION
JEFFERSON TOWN HIGH SCHOOL
 JEFFERSON TOWN, KENTUCKY
 HARTSTERN SCHNELL ASSOCIATES, I.A.A.
 200 MCDONELL BUILDING, LOUISVILLE, KENTUCKY

Questions relating to desirable traffic patterns should be answered before doors and auxiliary areas are located.
 Jefferson town (Kentucky) High School
 Hartstern, Schnell, Associates, Architects

the relative locations, the size, and the number of doors.

It is important also to make some basic decisions related to traffic control and building security early in the planning stage. Will there be times in the evening when only the music facilities of the building will be used? What schedule of keys for the building is desirable? For example, it may be wise to place certain auxiliary areas (instrument storage, music library, repair room) on the same key as the instrumental rehearsal hall so that band personnel can move freely with one key. Developing answers to certain questions related to the keying of the building can avoid annoying inconveniences or lack of proper security.

Careful planning is also needed with respect to parking. Though this is not a problem that concerns only the music department of a school there are certain aspects of the music program that may have special bearing on decisions related to parking. Typical of the questions for which the architect needs answers are the following:

1. Will the performing organizations perform away from school and will their travel involve moving heavy equipment?
2. Will the department present evening programs in the recital hall or auditorium?
3. Will community groups use the music suite at night?
4. Will noise in the parking area create a sound problem for music study?

Schools are sometimes faced with the possibility of converting existing buildings such as old auditoriums, gymnasiums, or cafeterias into music facilities. This can seldom be done successfully and where it is necessary usually ends up in compromise. A building committee should recommend a conversion only as a last resort since there is the distinct possibility that money so spent will produce inadequate results.

When conversion does seem wise, it will be found that large spaces lend themselves best to this possibility by giving the opportunity to construct a shell within the load-bearing walls of the building. Auditoriums, gymnasiums, and some old libraries offer this possibility and permit the necessary room height. Any building to be converted should be carefully examined by an engineer, an architect, and an acoustical consultant, as few old buildings have sufficient foundations to bear the heavy wall construction needed for adequate sound isolation and the added weight of a heavy ceiling. In examining old facilities, the matters of internal traffic and external accessibility should not be overlooked.

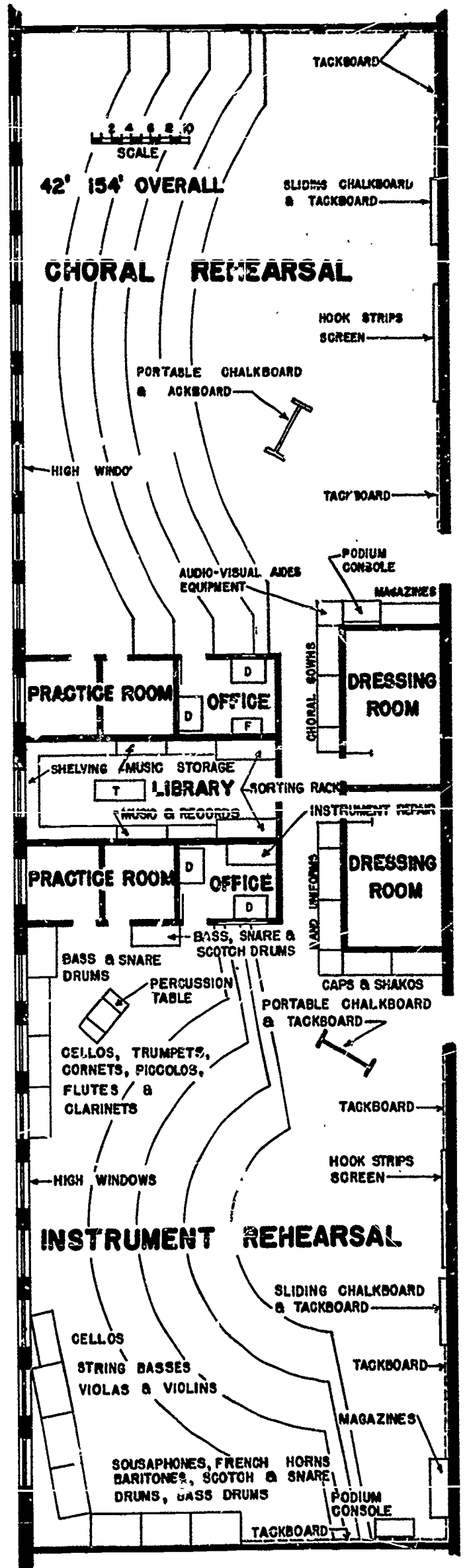

Plan for a two-teacher music department.

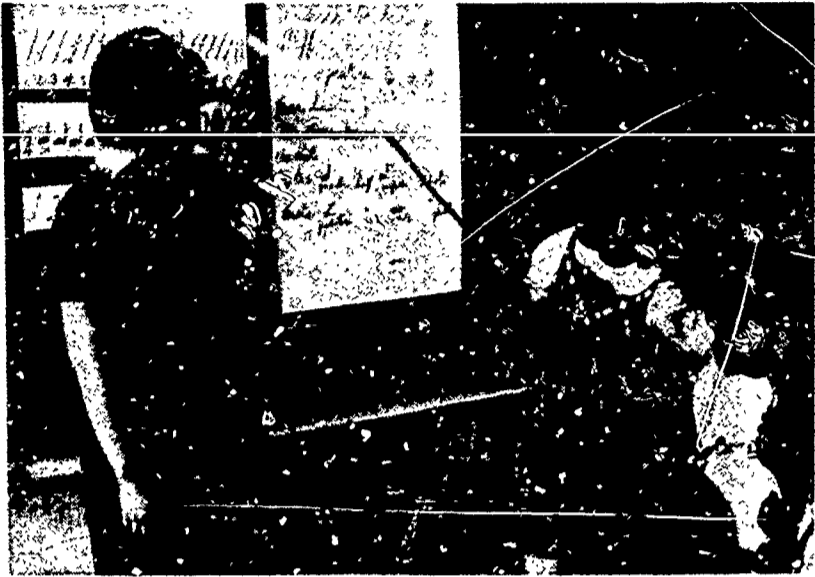

The architect needs to be told the nature of all the varied activities that might be undertaken in a general music class.

These admonitions are not intended to exclude the use of existing buildings for music purposes when the desired conditions can be met. It is necessary, however, to be certain that the desire for economy does not result in a facility entirely unsatisfactory for the music education process.

* * *

It has been the purpose of this brief discussion to indicate some of the steps to be taken in planning the music facility. Ways of determining the specific requirements in each of the major areas will be taken up in Chapter IV.

CHECKLIST FOR THE DIRECTOR OF MUSIC

(or Other Music Person Involved in Planning a Music Facility)

1. Have you and the teachers involved in the new building developed a philosophy of music education?
2. Does this philosophy reflect the newest ideas in music education so that you will be building for the future?
3. Do those who will carry on the instruction fully understand their roles in the program of music education?
4. Have these teachers been given the opportunity to request facilities that would make it possible for them to do their best teaching?
5. Have you made the architect fully familiar with the type of program you want to carry on in the new building?
6. Have you given the architect your best estimates of the numbers of people involved in each phase of the music program?
7. Have you indicated to the architect any special requirements in acoustics, lighting, location, heating, humidity control, etc., that are necessary to your program?
8. Have you worked with principal to determine how the music activities will be scheduled in the new building?
9. Have you determined the equipment which will be needed to make the new facility functional?

CHECKLIST FOR THE ADMINISTRATOR

1. Have you developed a general philosophy of education for your school?
2. Does your music staff understand this philosophy and their place in the overall program?
3. Have you determined the type of schedule the new school will follow and made certain that the music staff understands its implications for the music program?
4. Have you helped the music staff estimate the enrollments in the various activities planned in the music program?
5. Have you projected these enrollments for at least a five year period in order to build for the future?
6. Have you and the music staff considered the implications of community involvement in music activities?

CHECKLIST FOR THE ARCHITECT

1. Have you visited a school with a music program such as that desired in the school you are to plan?
2. Have you met with the music staff to find out just what it is they want to do in their teaching?
3. Are you familiar with the special problems of acoustics, lighting, sound transmission, traffic control, and humidity control which are associated with music teaching and public performances?
4. Are you prepared to suggest new ways for physical facilities to assist the music staff in reaching their objectives?

CHAPTER III

Location of Music Facilities

A MAJOR CONSIDERATION in planning music facilities is the location of the rooms, offices, and rehearsal areas. Many factors are involved, including the relationship of the various music areas to each other as well as to other parts of the school and to the site. The building plans and pictures in this chapter will serve to illustrate many points worthy of attention.

The location of music facilities in relation to the rest of the school plant must be made with convenience of movement of students and equipment in mind. There are distinct advantages to having the instrumental rehearsal hall near and on the same level as the auditorium. A corridor or storage area between the rehearsal area and the stage provides sound isolation. Second or third floor locations are to be avoided for instrumental rehearsal rooms unless a service elevator is provided for the heavy instruments and equipment. The music unit should have a direct outside entrance near the parking lot. A loading dock near the stage and music suite should be easily reached from either the street or driveways. An outside entrance to the drill field should be a consideration where marching bands are involved. The music suite should comprise a compact unit, especially when

there is only one teacher responsible for supervising all of the activities.

Though convenience to the rest of the school is a factor, a certain degree of isolation may be desirable to avoid disturbance of other classes or because the music unit is frequently to be used at night when the rest of the building is locked. Separate music buildings provide answers to some of the questions but at the sacrifice of ease of travel to the rest of the school. Fine Arts Centers in campus type schools have provided solutions in some situations.

A stage built in conjunction with a gymnasium and used as a music room is most undesirable. Scheduling problems are certain to arise from such a compromise. A music rehearsal cannot be conducted during gym classes or basketball practice. *Curtains and room dividers do not provide sufficient barrier to sound for music purposes.* Multipurpose rooms of other types are not recommended for music use. Basement locations are considered poor because of dampness (which will damage valuable instruments), poor lighting, and inconvenience.

Some schools have utilized some of the space underneath the bleachers in football stadiums; others have

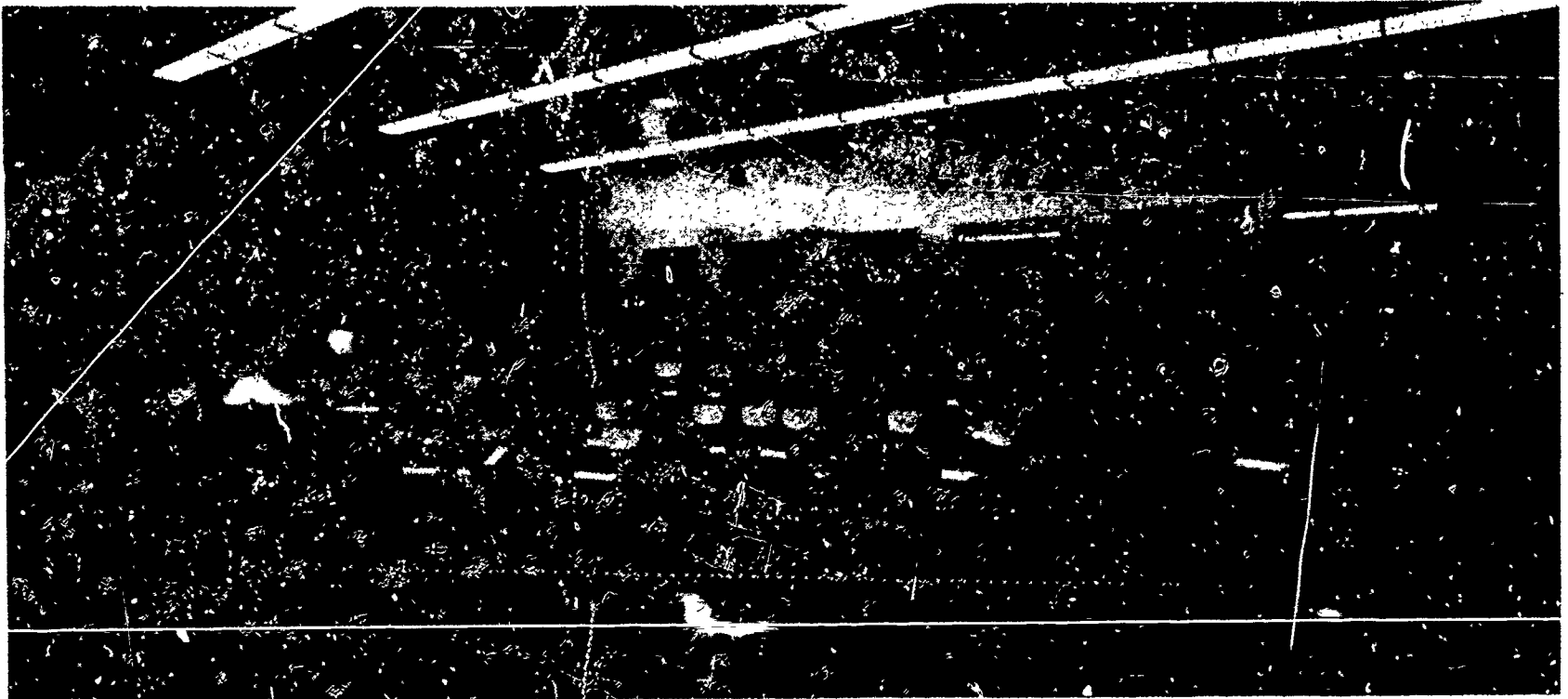

There may be advantages to having practice rooms located so that they may be kept under observation by the teacher working in the larger area.

Del Norte High School, Albuquerque, New Mexico
W. C. Krueger & Associates, Architects

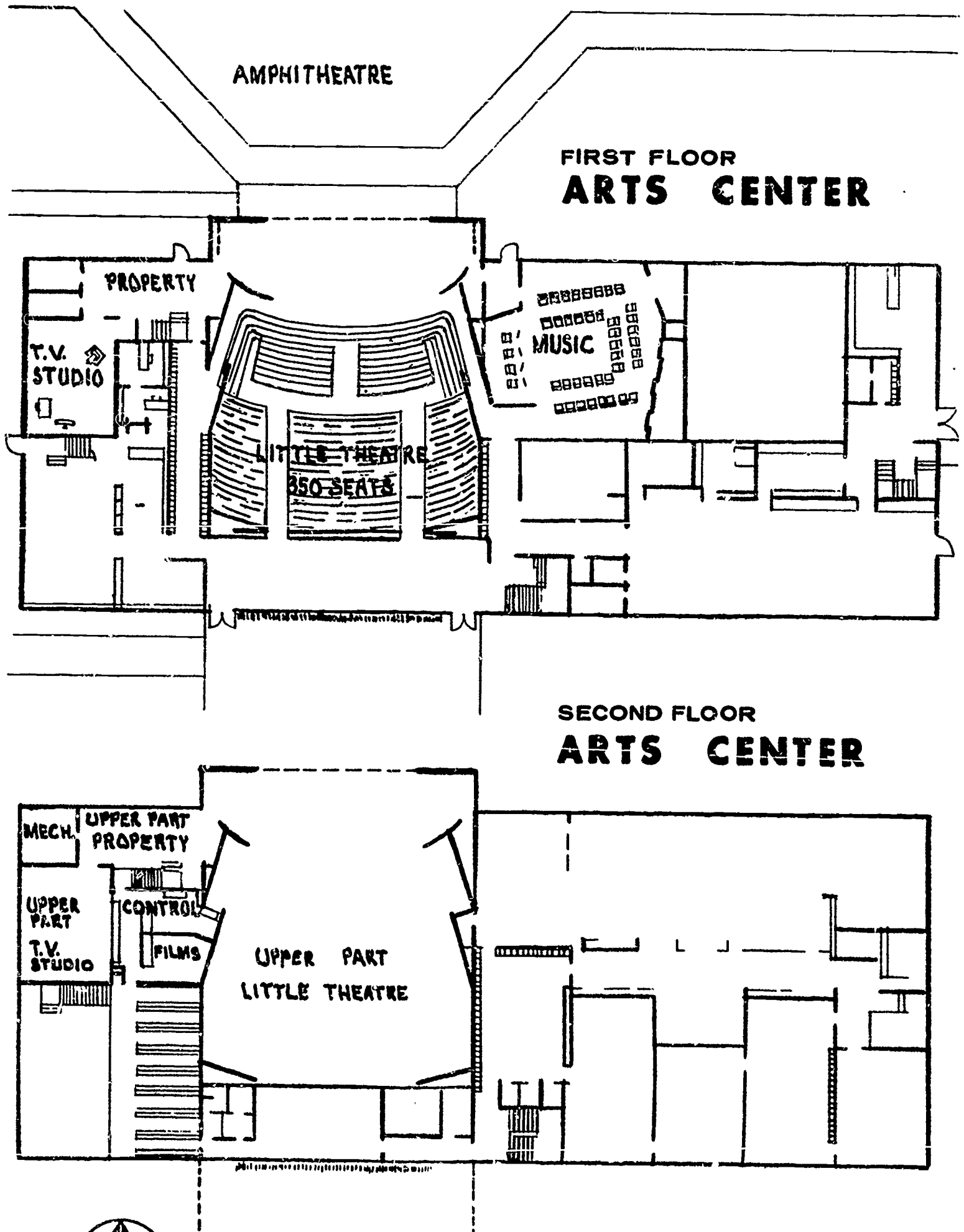

Art centers in campus type schools make possible cooperation between departments on projects of mutual interest and value.

Wayland (Massachusetts) High School

The Architects Collaborative, John C. Harkness, Herbert K. Gallagher

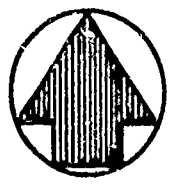
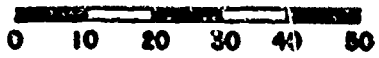

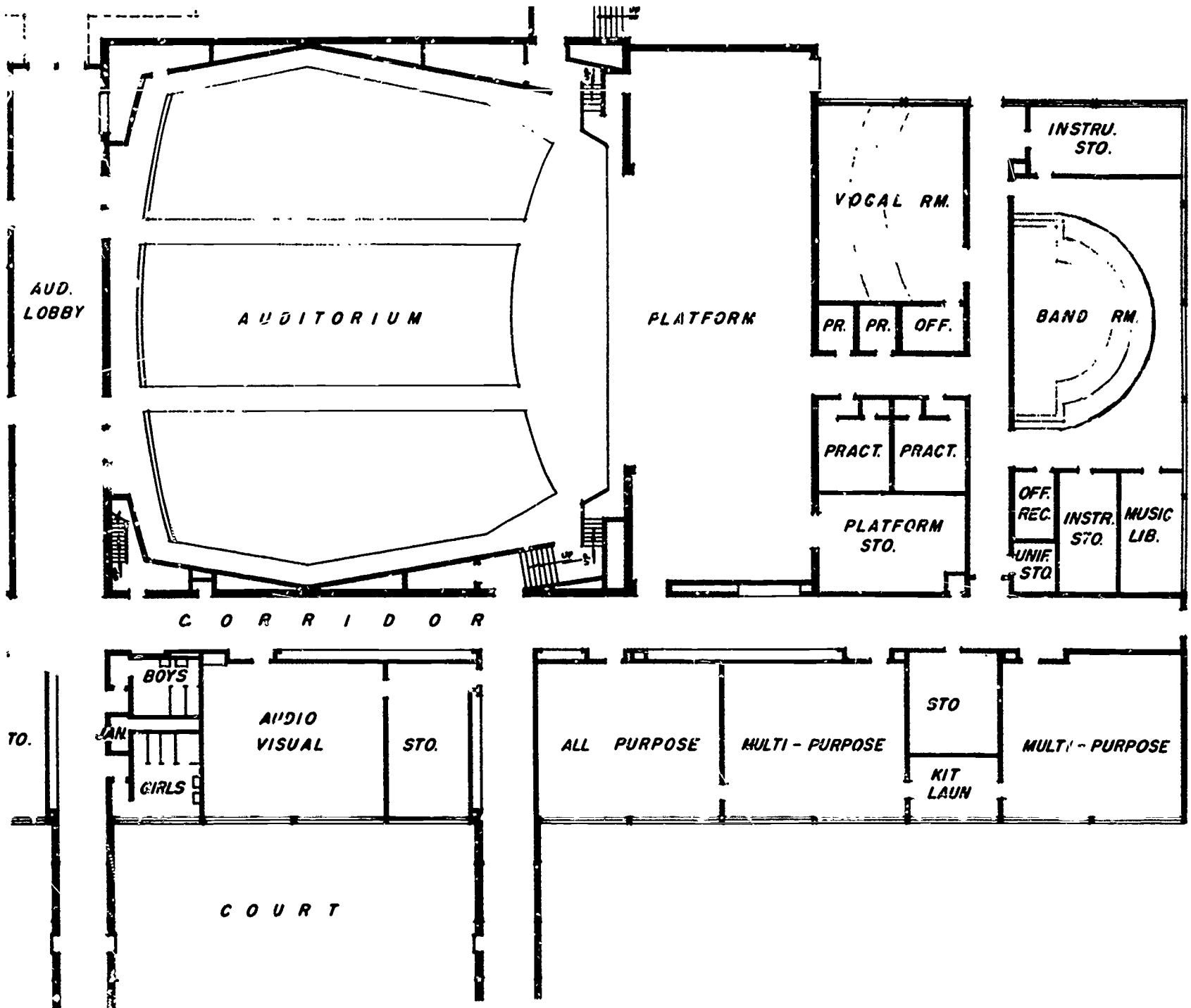

Easy access from the instrumental rehearsal room to the stage is highly desirable.
 Hanover (Pennsylvania) High School
 Hunter, Campbell & Rea, Architects

found potential large rehearsal areas above school garages. Planners should be cautioned about the dangers of compromises, however, and reminded that great care must be given to all aspects of the problem.

Schools and communities frequently plan for outdoor musical performance areas. One aspect of outdoor music performance that is sometimes overlooked is the need for a very quiet site. It is hopeless to try to perform music outdoors in a noisy city environment. The sound, of course, can be amplified to override the high level of background noise from traffic, but the whole thing becomes a caricature, not a real performance. The ancient Greeks and Romans understood the problem quite well when they seated the audiences for their

theatres on steep hillsides, and of course, they didn't have modern traffic to destroy audibility. The really successful outdoor concert facilities are always in quiet locations.

In the preliminary discussions with the architect the music staff should express preferences with respect to the location of the various elements of the music department. The music staff and the administration of the school should also indicate their thoughts with respect to the location of the music department in relation to the total school. Once these requests have been made to the architect, it is his responsibility to achieve these goals in the way which, in his professional judgment, seems best, taking into consideration such factors as the site, materials of construction, and budgeted funds.

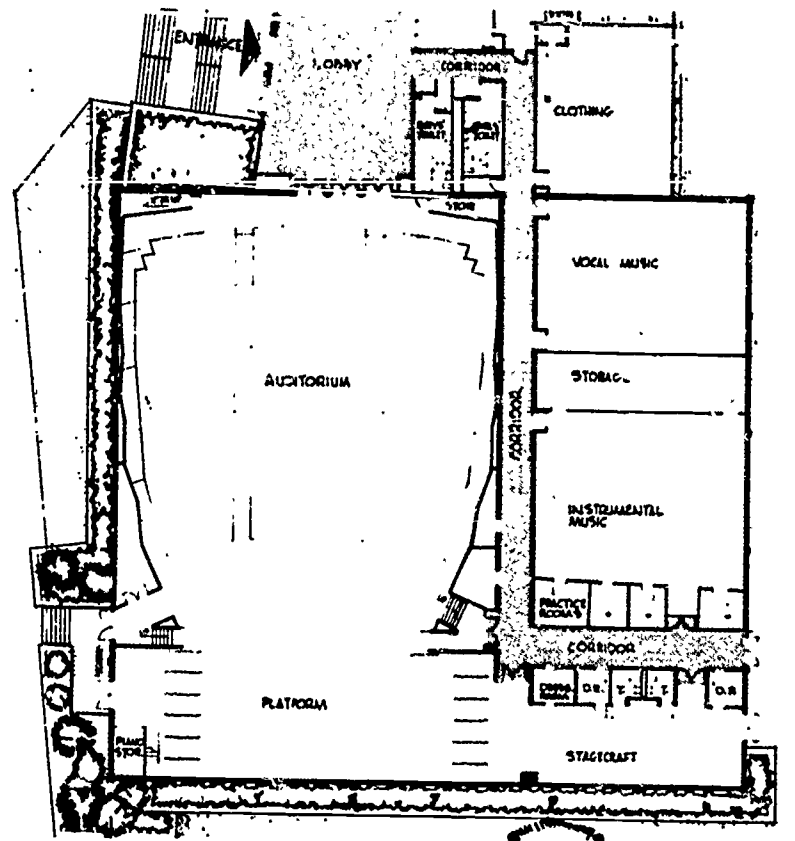
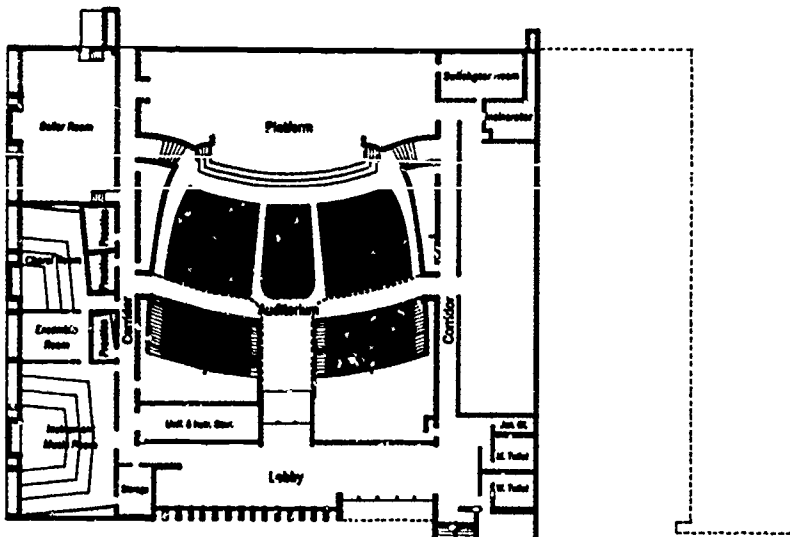

A corridor separating the music suite from the auditorium helps provide sound isolation if the doors are kept closed.
 Lower Merion School, Ardmore, Pennsylvania
 H. A. Kuljian & Company, Architects

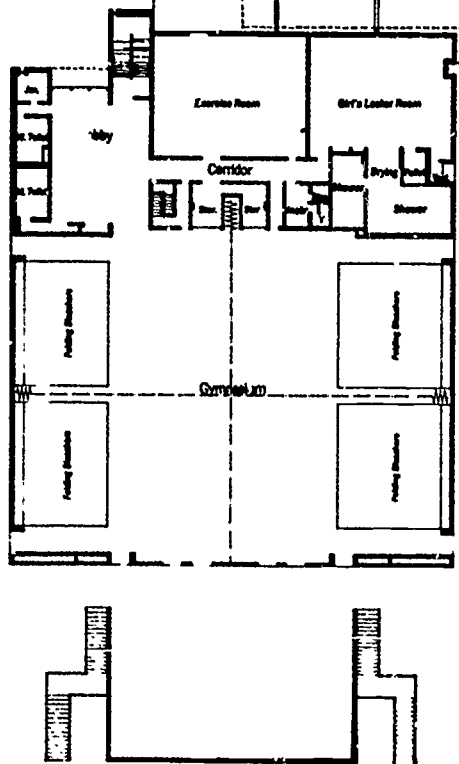

The music unit should be arranged to be used at night when the rest of the building may be locked.
 Whitesboro (New York) Senior High School
 The Perkins & Will Partnership
 Frank C. Delle Cese, Associate Architect

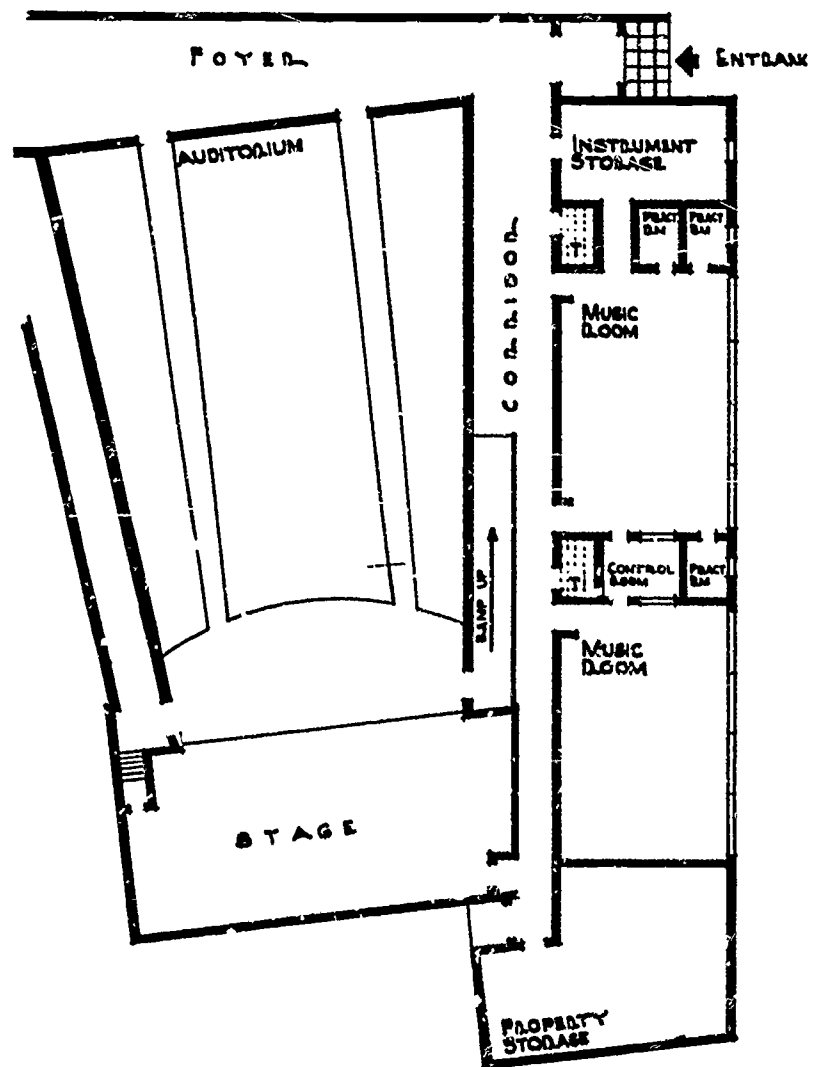

A recording studio between the vocal and instrumental rehearsal halls is a forward-looking idea.
 Harper Elementary School
 Evansville, Indiana

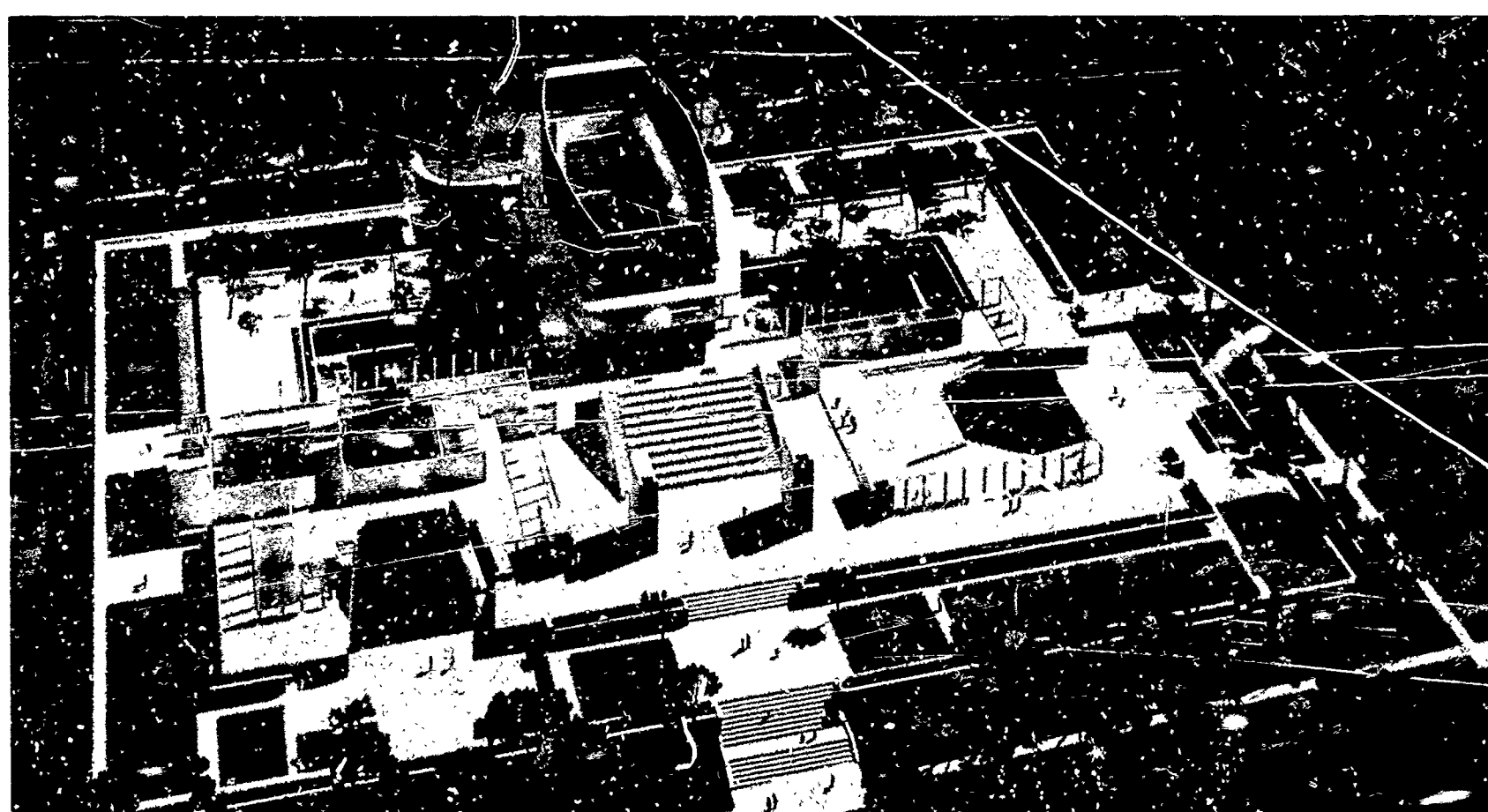
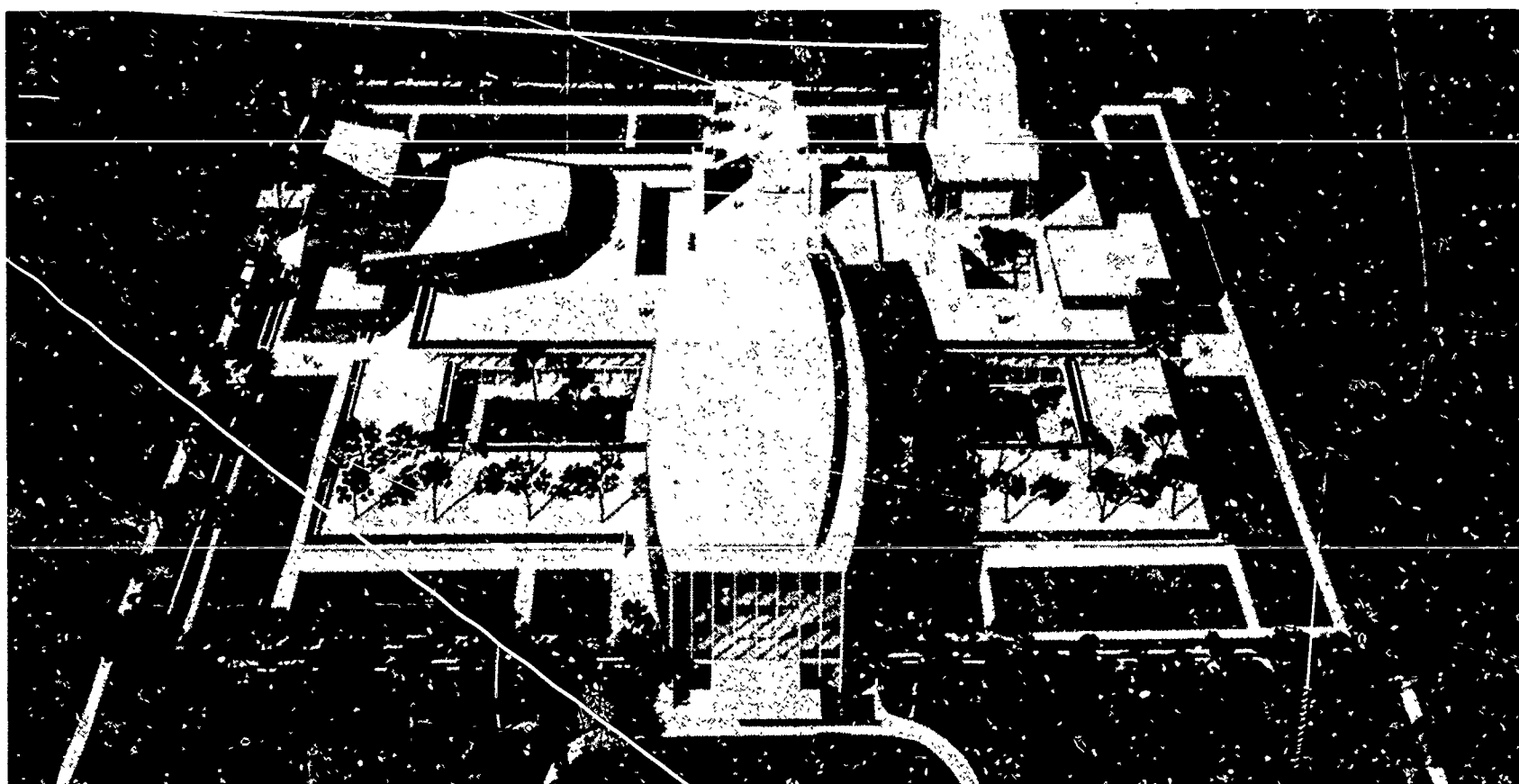

The Kiannert Center for the Performing Arts of the University of Illinois will group in a two-block area a 2,200-seat music auditorium, a music theatre for 1,000, a drama theatre to seat 700, and an experimental theatre for 250. The stairs in the middle of the Center provide outdoor seating for approximately 1,000. The lower photo shows the model with roofs and outer walls removed and displays the inner wall of wood in the music auditorium. Two floors underground will provide classrooms, practice rooms, rehearsal areas, offices, dressing rooms, and workshop. Parking for 800 cars is also underground.

Max Abramovitz, Architect

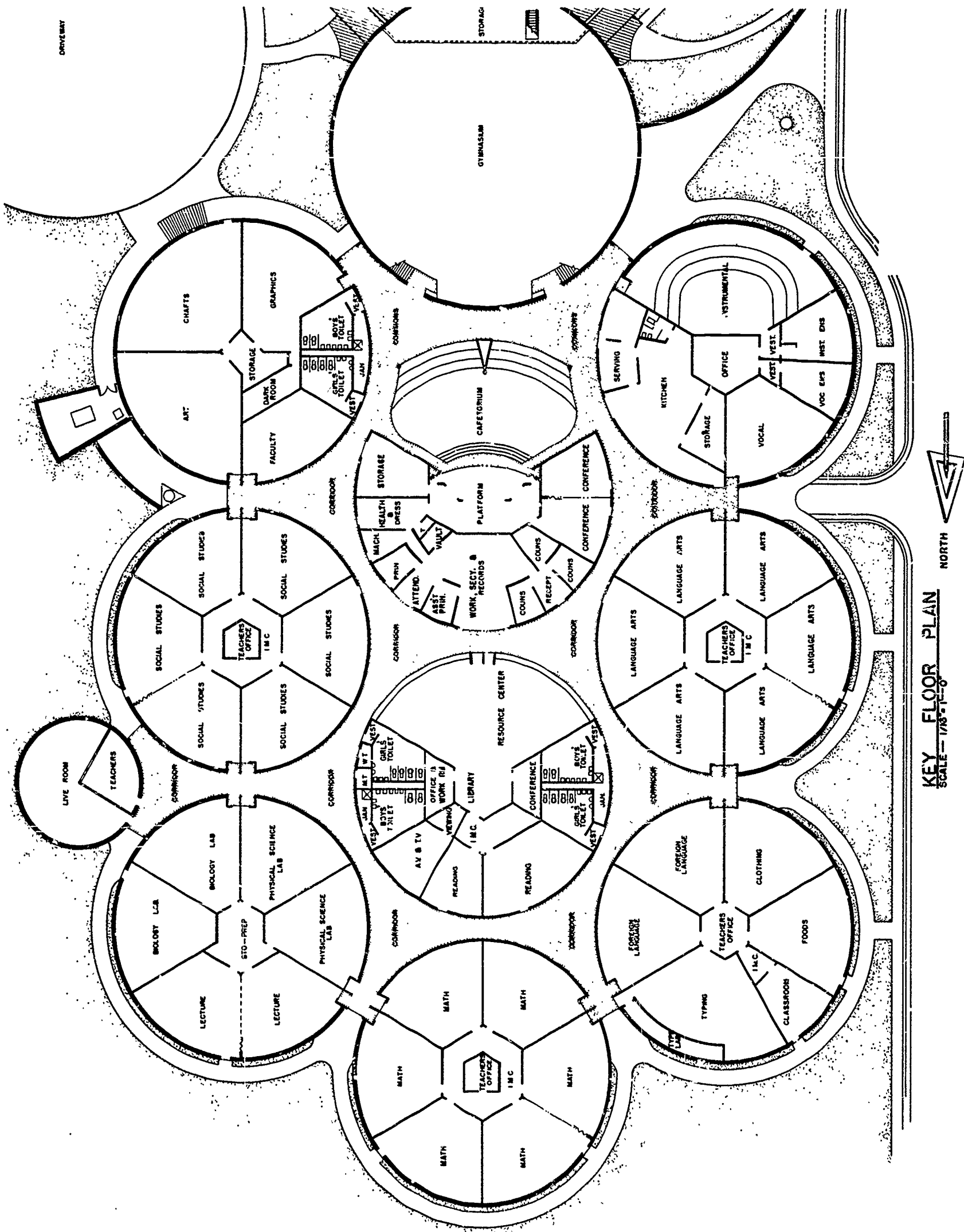

KEY FLOOR PLAN
SCALE - 1/8" = 1'-0"
NORTH

The music suite should comprise a compact unit and provide convenience of student movement.
Junior High School, Greeley, Colorado
Shaver & Company, Architects

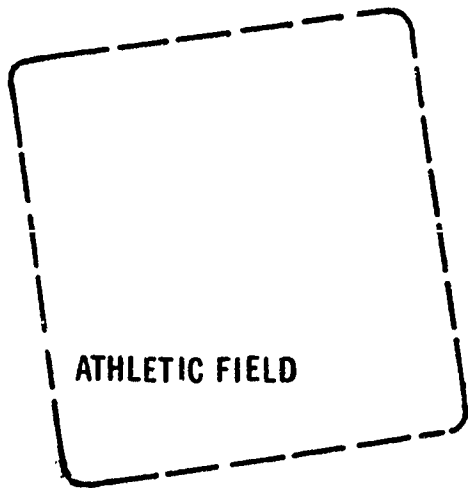

ATHLETIC FIELD

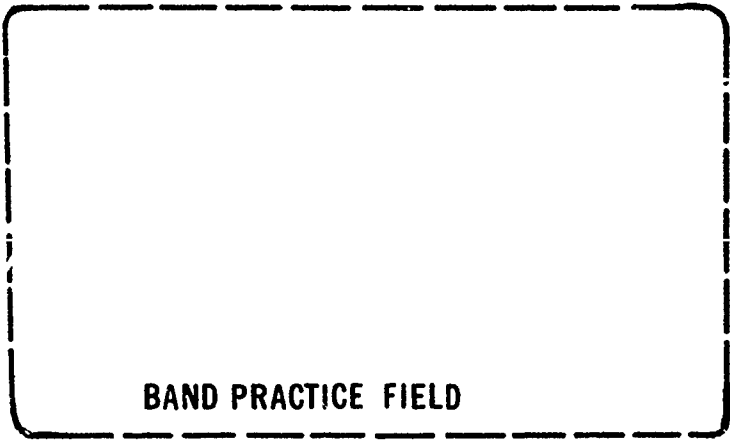

BAND PRACTICE FIELD

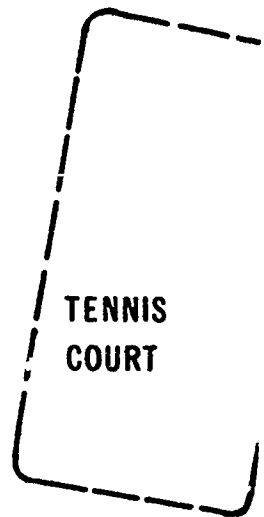

TENNIS COURT

PARKING

PARKING

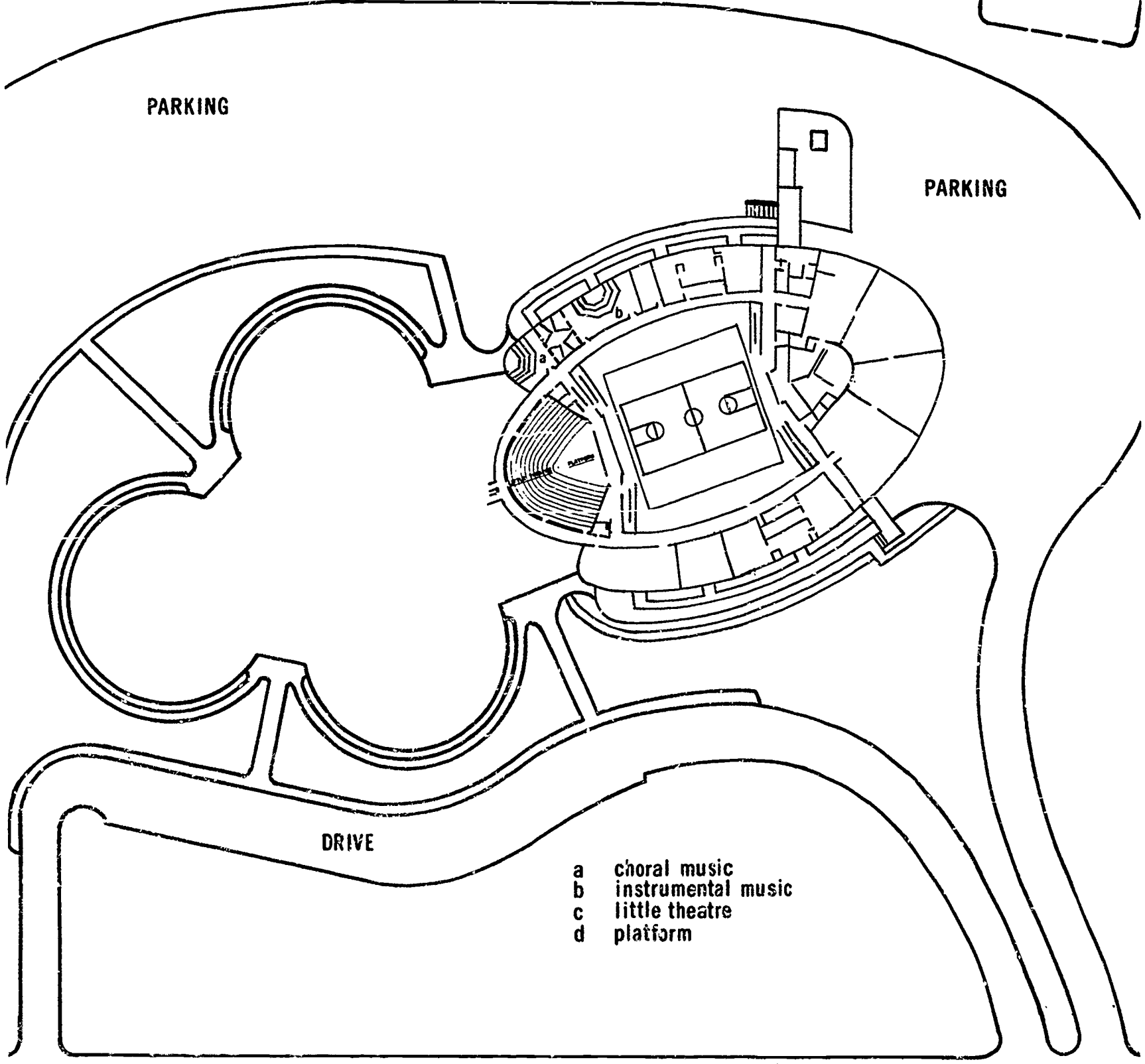

DRIVE

- a choral music
- b instrumental music
- c little theatre
- d platform

An outside entrance from the instrumental suite leading to the marching practice field is desired by most band directors. Parking should be convenient to the music suite but not close enough to be disturbing.
 Clarksville-Montgomery High School, Clarksville, Tennessee
 Shaver & Company, Architects

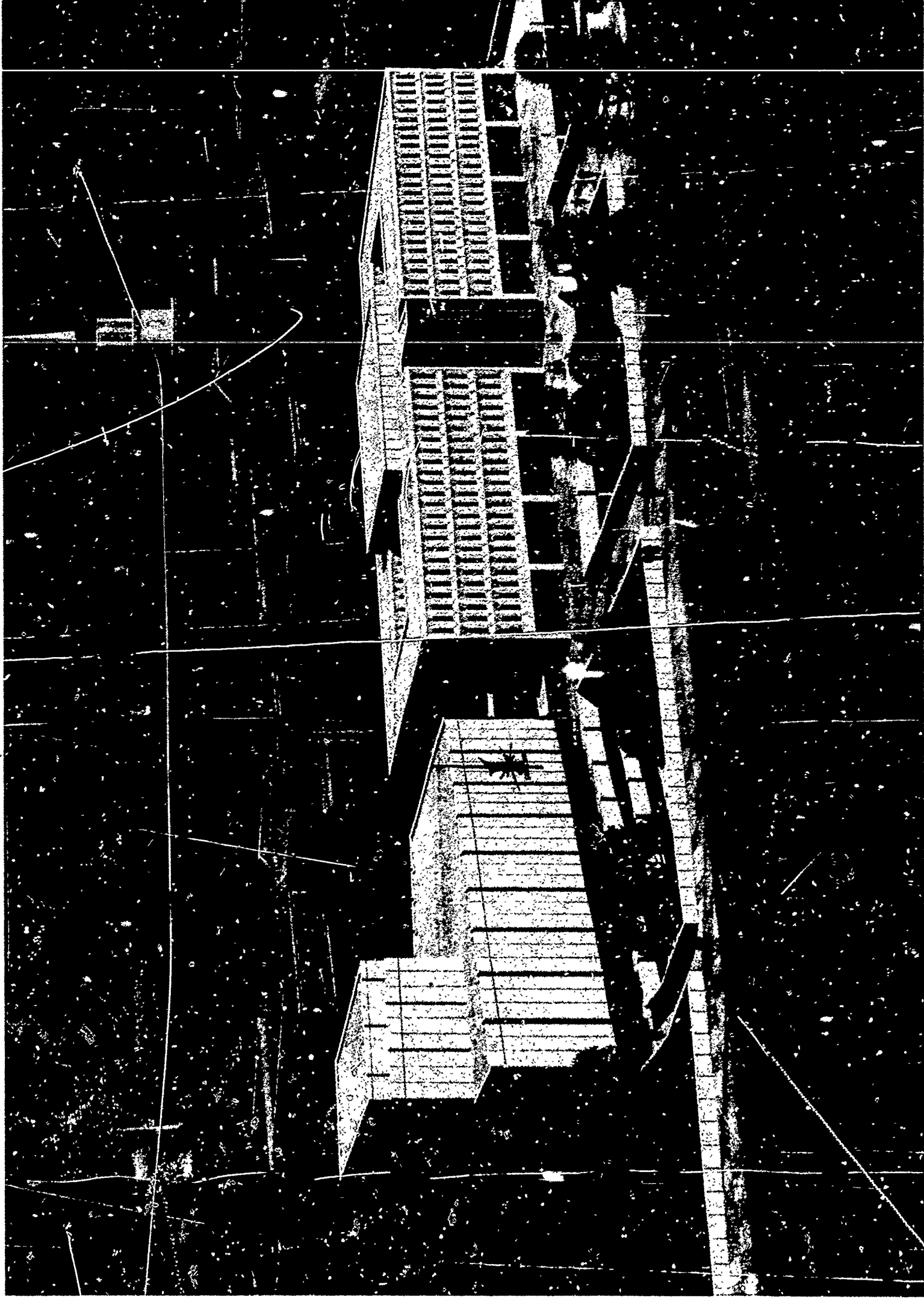

By taking advantage of a ravine in the midst of a crowded college campus the architect was able to provide three levels of parking below the four floors of classrooms, offices, studios, and practice rooms. The same deep site made it possible to plan a two-story orchestral rehearsal hall and a recital hall beneath the main auditorium.
College Conservatory of Music, University of Cincinnati
Edward J. Schulte and Associates, Architect

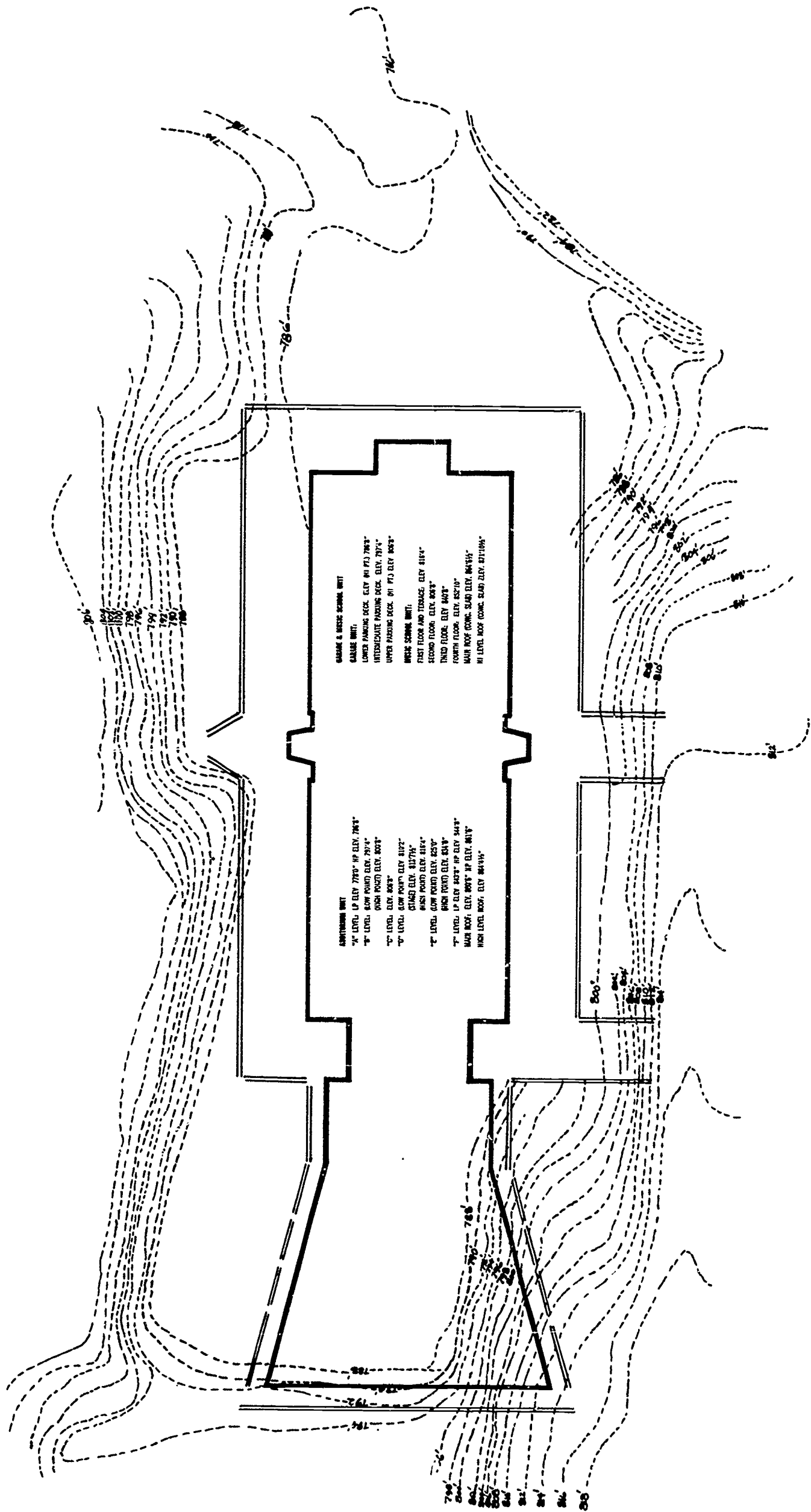

GARAGE & BASIC SERVICE UNIT
CLARKE UNIT:
 LOWER PARKING DECK. ELEV. @11 FTJ. 7893"
 INTERMEDIATE PARKING DECK. ELEV. 7874"
 UPPER PARKING DECK. @11 FTJ. ELEV. 8053"
BASIC SERVICE UNIT:
 FIRST FLOOR AND TERRACE. ELEV. 8154"
 SECOND FLOOR. ELEV. 8083"
 THIRD FLOOR. ELEV. 8073"
 FOURTH FLOOR. ELEV. 83270"
 MAIN ROOF CONC. SLAB. ELEV. 84475"
 HI LEVEL ROOF CONC. SLAB. ELEV. 8711094"

ADMINISTRATIVE UNIT
 "A" LEVEL. LP ELEV. 7780" HP ELEV. 7823"
 "B" LEVEL. LOW POINT. ELEV. 7974"
 "C" LEVEL. HIGH POINT. ELEV. 8053"
 "D" LEVEL. LOW POINT. ELEV. 8122"
 "E" LEVEL. STAGED ELEV. 81575"
 "F" LEVEL. HIGH POINT. ELEV. 8234"
 "G" LEVEL. LOW POINT. ELEV. 8234"
 "H" LEVEL. LP ELEV. 8403" HP ELEV. 8443"
 MAIN ROOF. ELEV. 8053" HP ELEV. 8414"
 HIGH LEVEL ROOF. ELEV. 84434"

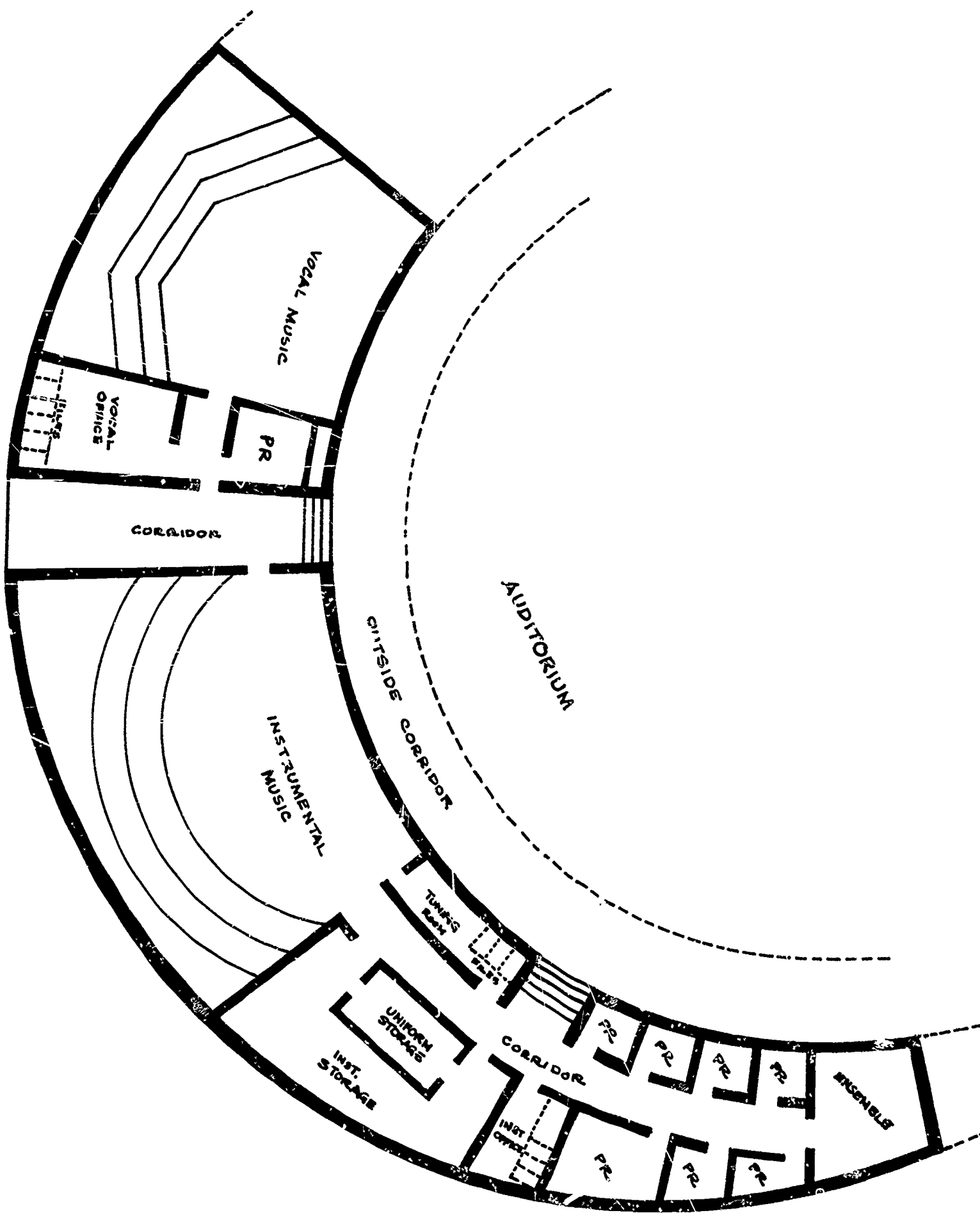

Storage areas should be located conveniently in relation to rehearsal halls. Note the tuning room across from the instrumental storage area and adjacent to the rehearsal hall.
White Bear Lake (Minnesota) High School
Haarstick, Lundgren and Associates, Architects

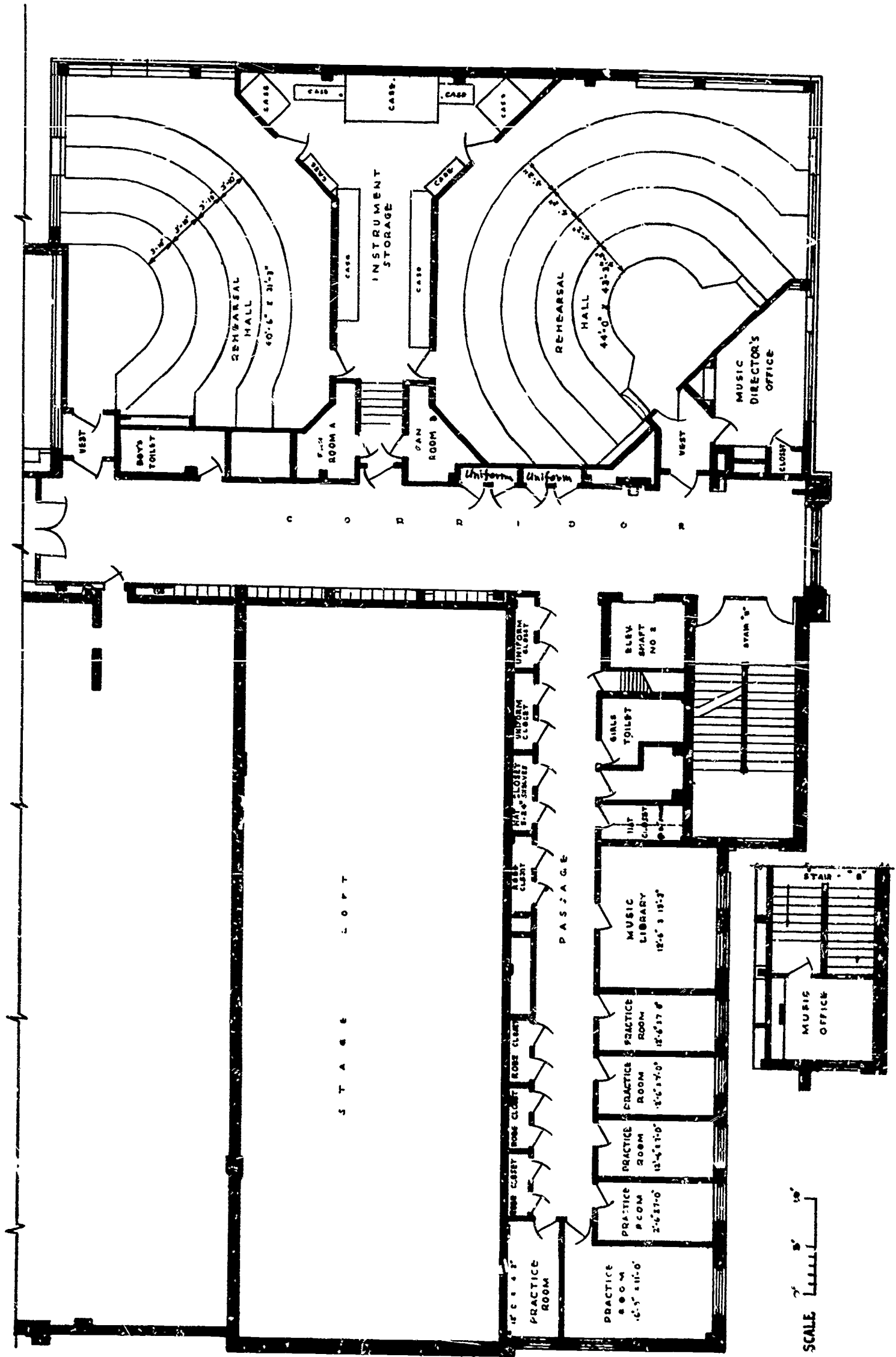

SCALE 1" = 10'

Where instrumental rehearsal rooms are not on the ground floor an elevator should be provided.
 Sexton High School, Lansing, Michigan
 Clark R. Ackley, Architect



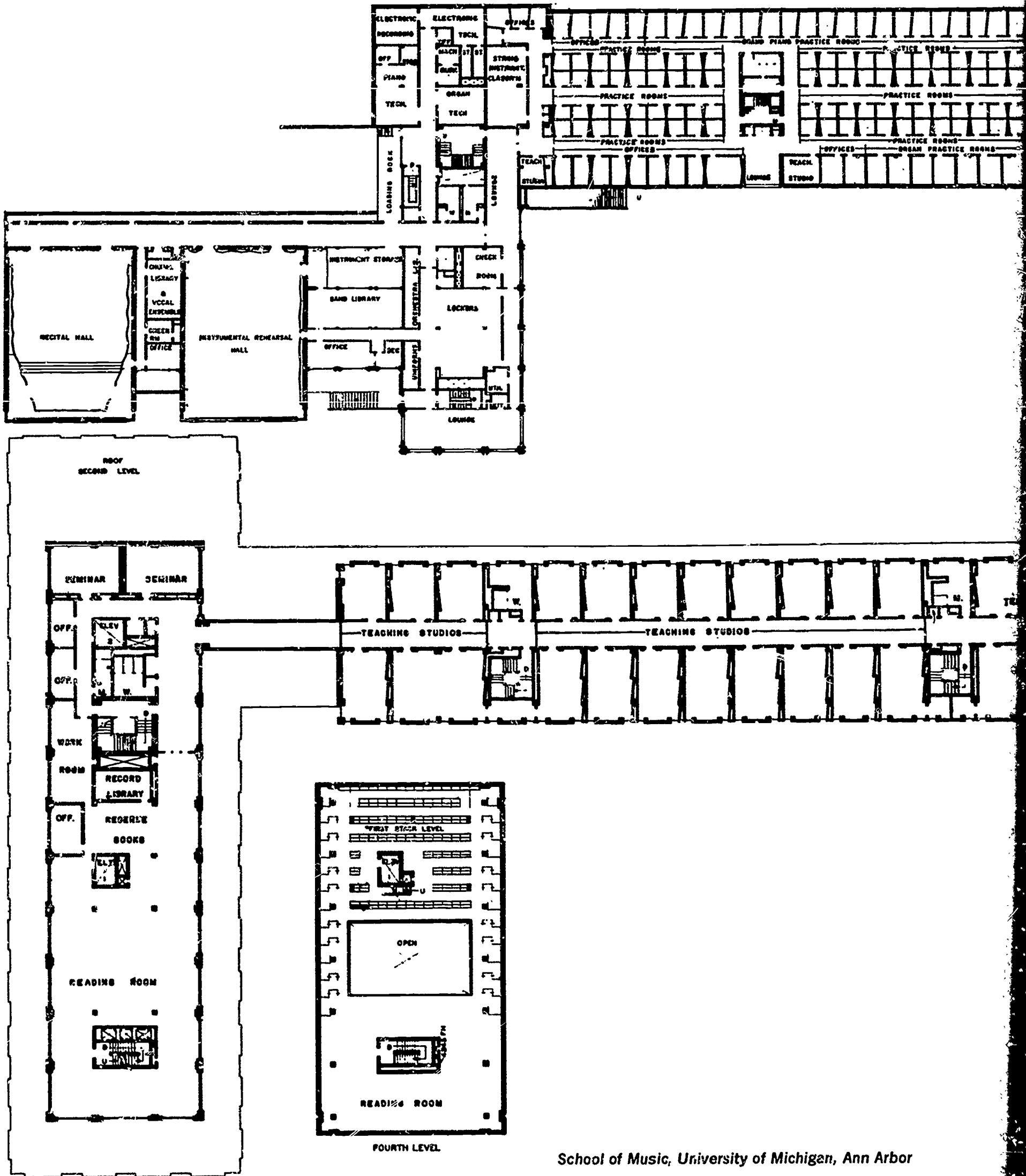

School of Music, University of Michigan, Ann Arbor

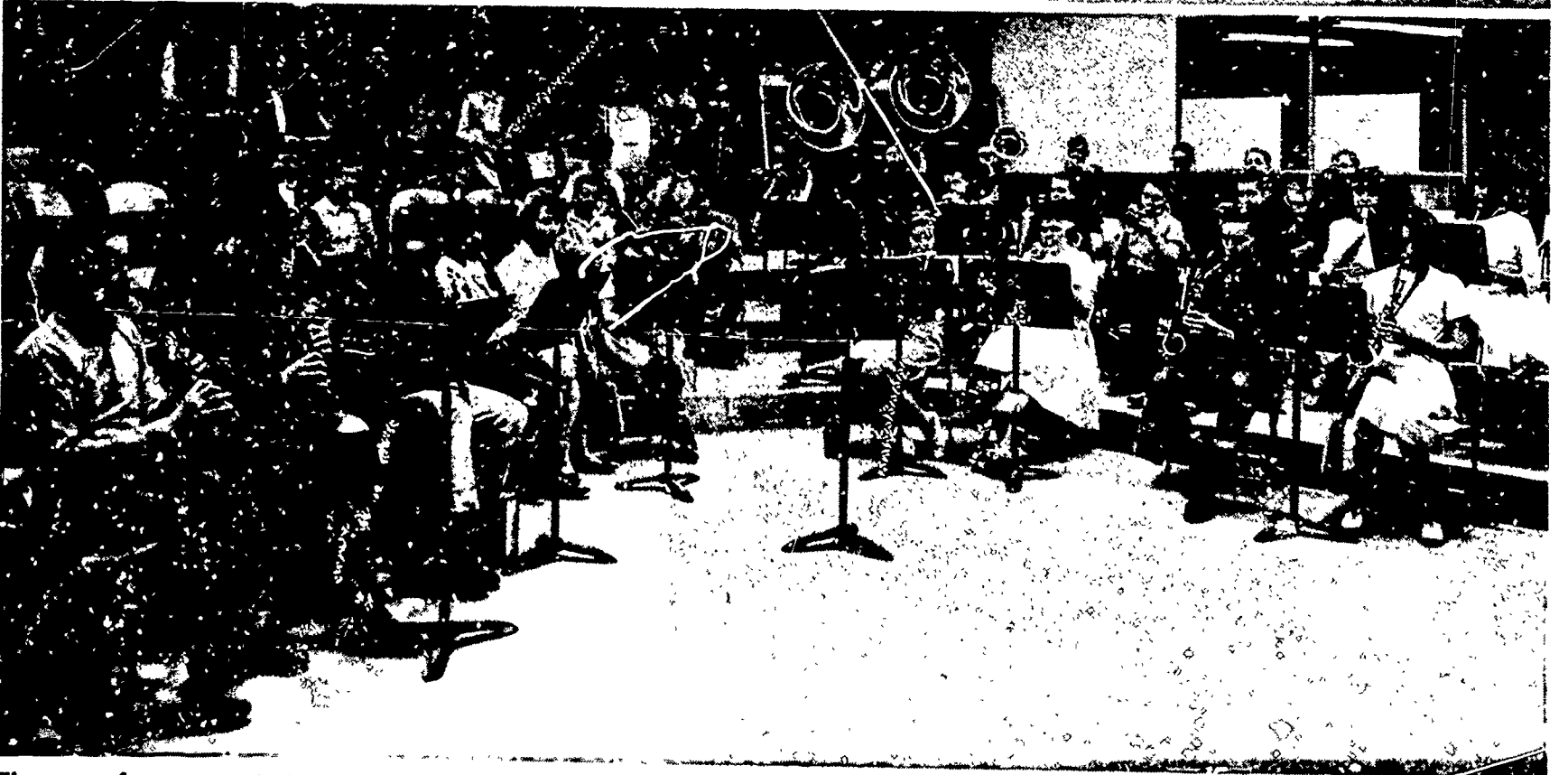

The use of permanent risers in an instrumental room seems to be a matter of personal preference.

*Henry D. Sheldon High School, Eugene, Oregon
Lutes and Amundson, Architects*

*Cy Junior High School, Casper, Wyoming
Perkins & Will, Architects, Robert Vehrli, Associate*

INSTRUCTIONAL AREAS

REHEARSAL HALLS

Instrumental Rooms

An instrumental rehearsal room obviously should be large enough to accommodate the largest band, orchestra, or combined group expected to use the facility. The needs may vary from one section of the country to another but 80 to 120 pupils may be taken as the normal range. In some areas which emphasize large bands it is not unusual, however, to find groups containing up to 180 pupils. The use of the school for community music activities should also be considered. Combined school and community groups may make it desirable to construct somewhat larger rehearsal facilities and provide additional storage space.

Room size.—In estimating the approximate number of square feet of floor space that should be provided for instrumental groups, one should allow 20 to 24 sq. ft. per student (i.e., 1600 to 1920 sq. ft. of floor space for an 80-piece band or a 60-piece orchestra). This will provide the necessary space for aisles, music stands, and other equipment. No student should sit against a wall, or stand within $7\frac{1}{2}$ ft. of the ceiling. This is especially true of the basses and percussion instruments who are frequently placed on the highest riser in the back of the ensemble.

Room height.—The height of an instrumental rehearsal hall depends on the number of students involved as well as the shape of the room. One of the frequent mistakes made in music facilities is the lack of sufficient ceiling height. Ceiling height must be planned for acoustic purposes even if a split-level effect is created on the floor above the music suite. Not all such rooms will be designed with a ceiling that is parallel to the floor so that an average ceiling height figure may be more meaningful than a simple number. This average will be in the neighborhood of 14 to 18 ft. Anything less than a 14-ft. ceiling in an instrumental rehearsal room should be questioned. Another check to ensure adequate space for proper acoustics in a rehearsal room is to allow approximately 400 cu. ft. per performer.

Risers.—Differences of opinion will be found concerning the desirability of providing risers in instrumental rooms. Pupils sitting in the back of the room and the far sides may have some difficulty in seeing the conductor unless they are seated on an elevation of some sort. No decided preference for flat floors or for risers has been demonstrated. Architects are currently designing music rooms of both types according to the preference of those planning the facilities. Whichever is used, flat floors

or risers, it will be necessary to make the appropriate adjustments to provide for diffusion of sound. With the use of risers, additional room height will be needed. Some schools feel that semi-permanent or portable risers solve the problem and provide room flexibility. The provision of sets of risers—one to be kept in the auditorium and another for the rehearsal hall—avoids some of the logistical problems but many directors who have risers in the rehearsal room find the flat floor of the stage satisfactory. Many symphony orchestras have abandoned the use of risers, their conductors having discovered that when the brass and percussion sections are elevated, they often overbalance the strings. This may be even more true with school orchestras. The problem presented by the lack of stage enclosures (shells) far outweighs the problem of whether or not to use risers on the stage. Risers that telescope into the wall are another possibility, but the expense involved may prohibit their use in many situations.

If risers are used, a width of 60 in. for most terraces will prove adequate. A 60-in. step will be wide enough for a single row of instrumentalists or two rows of singers. The top riser should be wider (up to 120 in.) since the back of the room ordinarily accommodates the larger percussion and bass instruments. Ordinarily, an elevation of 6 to 8 in. is adequate (sight line is a good indication of ear line). A white strip of paint or a rubberized non-skid tread on the edge of all risers provides an element of safety. The number of terraces will range from one to five, depending on the size of the room and the needs of the organizations using the rehearsal facilities.

Other considerations.—The instrumental rehearsal room will probably be used for instrumental classes and possibly even for theory or other music classes. Mounted chalkboards are therefore desirable. Since rehearsing is the room's principal function, however, no decision should be made that will detract from its ability to fulfill that role. The straight chairs required for performing groups should not be sacrificed for tablet armchairs. Provisions for closed-circuit television and a projection screen should be considered. Many rehearsal rooms being currently planned and built incorporate microphone outlets with adequate wiring leading to the control room.

If the room is to be used for orchestra rehearsals or cello classes some thought should be given to the effect of cello endpins on tile or wood flooring. One solution

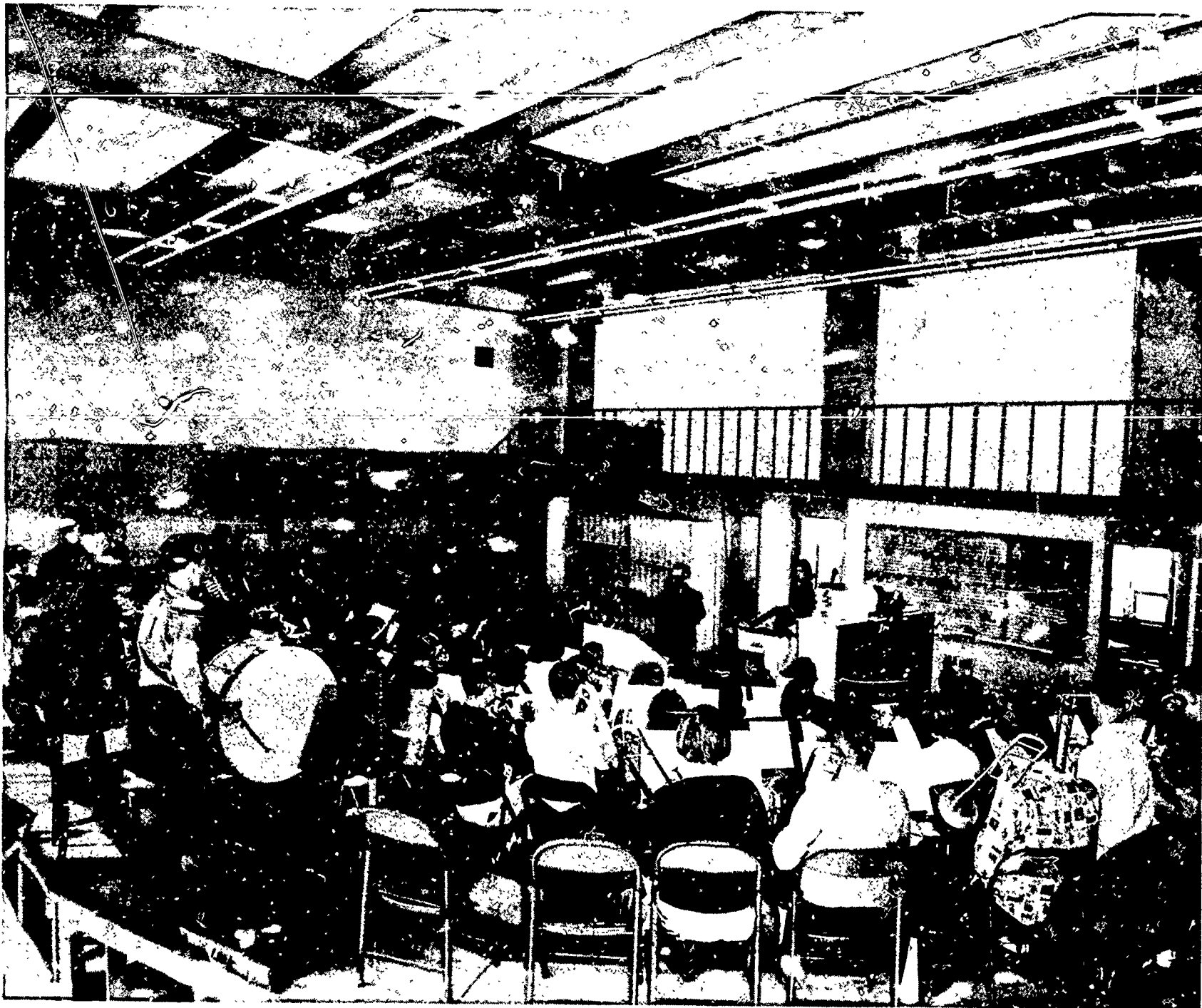

Adequate ceiling height is important for instrumental rehearsal halls.

*Magnolia (Arkansas) High School
Ginocchio, Cromwell, Carter & Neyland, Architects*

is to provide for $\frac{1}{4}$ -in plywood floor panels large enough to serve the player and his instrument.

Finally, it should be noted that there is some doubt as to the advisability of bands and orchestras using the same rooms. Recent research has indicated that, for teaching purposes, the band requires a much less reverberant room than does the orchestra.

Choral Rooms

The specialized requirements of choral rehearsal rooms are somewhat different from those facilities used exclusively for instrumental groups. Space requirements are simplified since it is not necessary to provide floor

area for music stands and instruments. If the vocal groups are to stand for rehearsals, 6 sq. ft. per pupil will suffice. The use of fixed chairs on risers will require more space; at least 10 sq. ft. is necessary for each pupil if the risers are the minimum width of 30 in. Extra space should be planned if wider (36 in. or 40 in.) risers are preferred, 15 to 18 sq. ft. per person being not unusual. Choral room ceilings do not need to be as high as those in instrumental rehearsal halls, but should be higher than those in an ordinary classroom.

Risers.—Few if any large choral groups rehearse or perform without the use of risers. They are used to avoid having the tone of singers in the back rows ob-



Where risers are used, the top level should be at least 120 inches wide to accommodate the larger instruments.
 Rehearsal Room and Recording Studio
 University of New Mexico, Albuquerque

structed by the bodies of the singers in front. They are also essential for easy observation of the conductor. An elevation of 6 to 10 in. and a width of 40 in. is adequate for permanent or semi-permanent choral risers.

Few choral directors desire an aisle in the center of the room. This may be avoided if the width of the riser and the distance between seat rows is sufficient to allow convenient passage. Safety regulations differ, but risers 40 in. wide are adequate to meet the requirements in most areas.

Since the choral room is most likely to be used as a general classroom in non-choral hours, folding tablet armchairs will be useful for both classroom and rehearsal functions. Fixed opera (theatre) chairs are sometimes

employed in choral rooms, especially when the room is designed to serve as a recital hall. In all probability choral directors will want to make recommendations concerning the chairs to ensure proper support for the lower back of the singers. Not less than 125 cu. ft. of space per seat should be provided in recital hall-choral rooms.

Some choir directors prefer to have their groups stand for rehearsals as well as for concerts. In such cases the riser should have a width of approximately 15 in. and a height of 8 or 10 in. per step. A permanent or portable stage is an advantage for a choral room. Three or four steps from the floor of the room to the stage can be designed to serve as permanent standing risers.

- 1 Shelving and/or cabinets for storage of books, records, etc.
 - 2 Chalkboard
 - 3 Tackboard
 - 4 Gown and/or uniform storage
 - 5 General storage cabinet
 - 6 Sink
 - 7 Sorting rack
 - 8 Portable chalkboard
 - 9 Instrument storage
- Scale: $\frac{1}{8}'' = 1'0''$

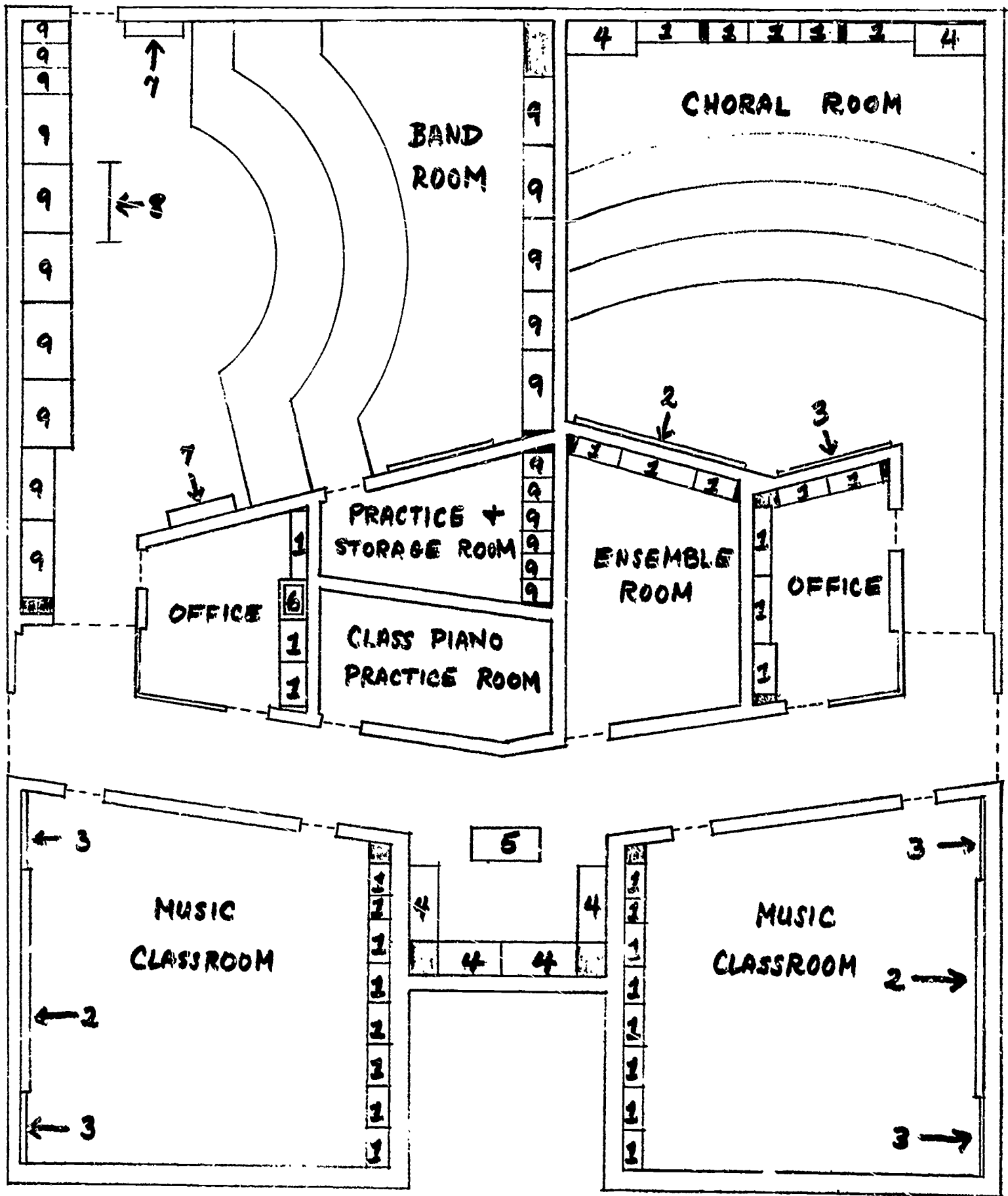

Larger practice rooms reflect the increased emphasis on small ensembles both vocal and instrumental.
 Governor Thomas Johnson High School, Frederick, Maryland
 Henry Powell Hopkins and Associates, Architects

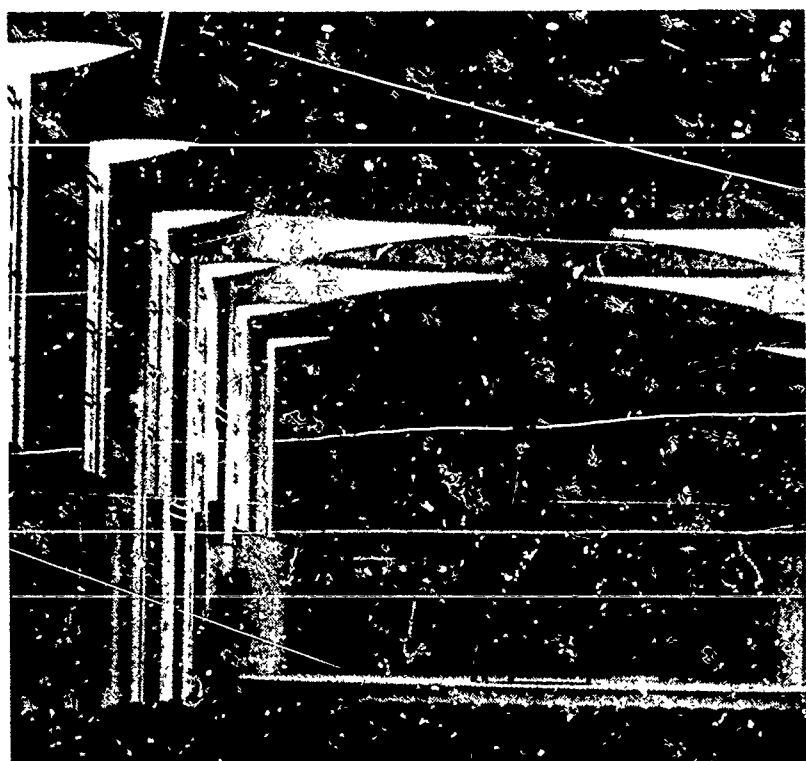

Full width steps leading to a stage can provide permanent risers for choral or other groups.

James K. Polk Elementary School

Alexandria, Virginia

Vosbeck-Vosbeck & Associates, Architects

Other considerations.—The use of the choral room for other than rehearsal functions suggests the advisability of providing chalkboards, a projection screen, and closed circuit television. Microphone outlets for recording and broadcasting should be considered. Schools being built now should be planned to make possible the use of performing groups for broadening the cultural life of the whole school.

Combined Vocal-Instrumental Facilities

Let it be said at the outset that acoustically, one room cannot serve for both vocal and instrumental rehearsals with completely satisfactory results. Some communities, however, find it economically unsound to provide space for both instrumental and vocal groups while employing only one teacher. It is therefore ex-

pedient to consider space for the combined vocal-instrumental situations. Provisions for changing the reverberation characteristics of such a room with drapes or other materials is a possibility.

In many one-teacher situations, one room is the nucleus of all music activities. In the smallest of music departments a single, all-purpose room can be planned *in terms of space* to accommodate the vocal and instrumental group rehearsals, small ensembles and individual rehearsals, library, instrument and equipment storage, instrument repair facilities, office, and teaching studio as well as various other music classes insofar as the scheduled school day permits. Although space can be provided for this multipurpose situation, few of these activities can be adequately housed in one room without creating undesirable acoustical conditions for the other activities. It may be dangerous to ask elementary school children and the majority of junior high school pupils to sing in such compromise situations. While variable acoustical control may be employed, the installation of such materials may be more expensive than providing additional facilities. When possible, separate special rooms for instrumental and choral activities should be provided since vocal groups require a much "warmer" room than do bands and orchestras.

Space in such a combination room will have to be figured on the basis of the suggestions made for instrumental rehearsal halls. The room might be thought of as the future instrumental room, expansion to separate facilities being the ultimate goal.

PRACTICE ROOMS

Practice rooms are a facility peculiar to the teaching of music with some special problems not encountered by administrators or architects in planning other elements of the school. Among the factors which must be considered are isolation of sound, size, ventilation, amount of use, and supervision.

Number.—The number of practice rooms needed by a music department should be related to the number of

Table 1

50 music majors	×	16 hr. per week	=	800 hr. per week
40 on secondary instruments	×	6 hr. per week	=	240 hr. per week
80 theory students	×	2 hr. per week	=	160 hr. per week
150 elementary education students	×	2 hr. per week	=	300 hr. per week
				1500 hr. per week
<u>Practice hours per week</u>			=	$\frac{1500}{60}$
<u>Hours available for use per week</u>				=25 practice rooms needed

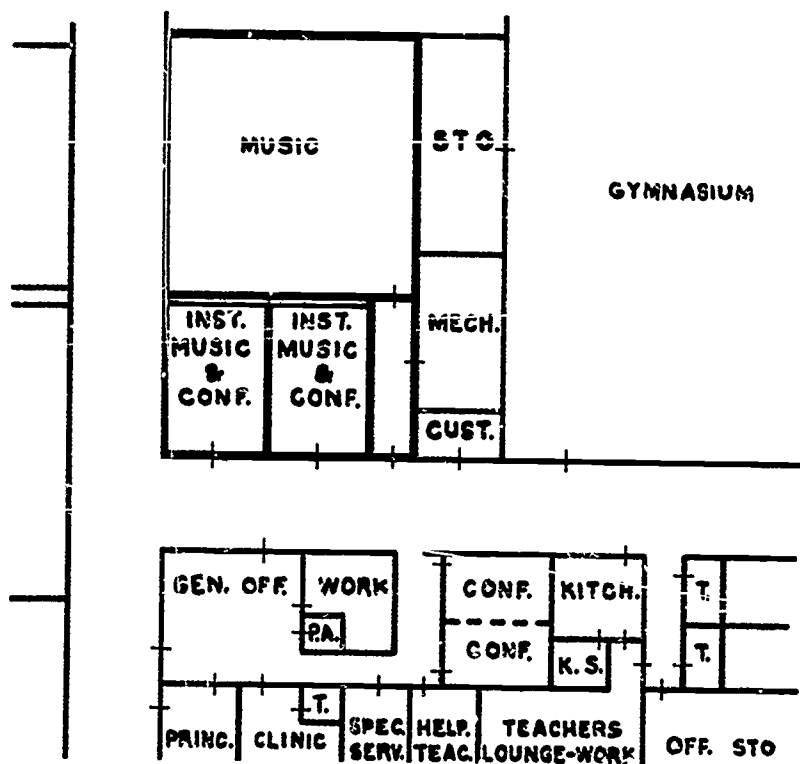

Rooms large enough to accommodate instrumental classes of 12 pupils are being called for in Ann Arbor, Michigan elementary schools rather than a single large area for instrumental music. Two visiting instrumental music teachers can thus hold classes simultaneously and the rooms have many other uses such as testing, speech correction, and remedial reading.

Stone Elementary School, Ann Arbor, Michigan
Cummins and Barnard, Inc., Architects

students involved and the administrative policies concerned with their use rather than by the amount of space created by the architect in splaying the back wall of the rehearsal hall. Some authorities recommend that students practice as much as possible in school, so that assistance and supervision are possible. Many feel that it is particularly important that practice room facilities are available for those students who play the larger instruments because of the difficulty in carrying the instruments home. These practice rooms should be convenient to the large rehearsal room, so that the moving of heavy large instruments is minimized. In determining the number of practice rooms needed by a collegiate school or department of music a calculation similar to that in Table I might be used.

Size.—Practice rooms vary in size according to their various functions. Individual practice rooms are quite satisfactory in the 55-65 sq. ft. range. This provides sufficient space for an upright piano, a chair, and a music stand—but little more. Public schools, once planned with several rooms of this size in the music suite, are now being built with slightly larger rooms for ensemble practice reflecting the increased emphasis on small groups, both vocal and instrumental. Colleges which plan large

blocks of small practice rooms will also want to provide a number of larger rooms for ensemble practice, or to accommodate grand pianos (2) or organs.

Other considerations.—More and more school buildings in the North as well as the South are being air conditioned and this is a distinct advantage where practice rooms are concerned. In fact, there is no other ways to provide proper sound isolation. If the building is air conditioned, the practice rooms can be arranged in blocks, spaced compactly, and planned without outside windows. Sound filters should be provided for the air ducts to prevent transmission of sound from one room to another, and the return air ducts should be placed in the ceilings or walls, not in the doors. Construction to ensure adequate transmission loss will make practice rooms more expensive than ordinary classrooms, but economies may be effected here with more justification than in some other parts of the music suite (see page 66).

Non-parallel walls have been widely used to avoid reflection of sound in these small rooms. Other suggestions dealing with acoustics in relation to practice rooms are found in Chapter VI. Double glass windows in the doors, or opening on the rehearsal hall or teacher's office in schools, permit supervision without interruption. Electronic monitoring devices are sometimes incorporated.

CLASS PIANO ROOMS

Many school systems are now providing class instruction in piano as well as in the band and orchestra instruments. Some schools have constructed specially designed rooms for this type of instruction. These rooms should be as near as possible to the other music rooms in order to realize complete utilization in a coordinated music program. There should be acoustical treatment of the walls and ceilings, and insulation against sound transmission to and from other classrooms as prescribed by the acoustical consultant. Careful consideration should be given to sound conditioning of rooms for class piano if several pianos are used, due to the percussive action of tone production of several performers. The front wall should be equipped with blackboard (plain and with music staves), bulletin board space, music cabinet, and electrical outlets. Space should be provided for television, phonograph, and recording facilities.

If electronic pianos are used in such a room, it is useful to provide an adequate number of electric outlets in the floor to avoid the need for extension cords and the hazard they present. Organ class instruction is now finding increasing favor in several of our larger cities and properly wired rooms should be planned if this activity is to be part of a school's program.

(This erratum note is printed on gummed paper and may be affixed to the top of this page and become a permanent part of this book.)



Class piano rooms need special consideration because of the percussive action of tones produced by several performers.
Department of Music, University of New Mexico, Albuquerque

REGULAR CLASSROOMS

Regular academic classrooms are used by many schools for classes in music history, appreciation, theory, composition, arranging, and other music education classes. Though the acoustical treatment may not need to be as extensive or expensive as in some other parts of the music suite, if the learning to take place in the room is to involve listening to music, more than ordinary care must be taken to block out extraneous sounds. A classroom that will be used primarily for general music classes needs ample storage space for books, records, rhythm instruments, autoharps, piano keyboards, pictures, and similar equipment. Provision should be made for a projector screen mounted at ceiling height or in a ceiling recess.

In some situations it may be possible to provide a projection room adjoining the classroom, or even between two classrooms, so that the projector can be prepared without losing classtime. If a classroom is to be used primarily for theory classes, it will be desirable to have staff lines painted on the chalkboard. Conversely, if music literature classes are to be the principal occupants, painted staff lines are less desirable. If a college classroom is to be used largely for music education classes, it will need adequate locked shelf space or will need to be planned adjacent to a storage room (with shelves) for the large amount of material used in such classes. In a campus school situation, classrooms may need to be provided with rows of coat hooks and shelf space.

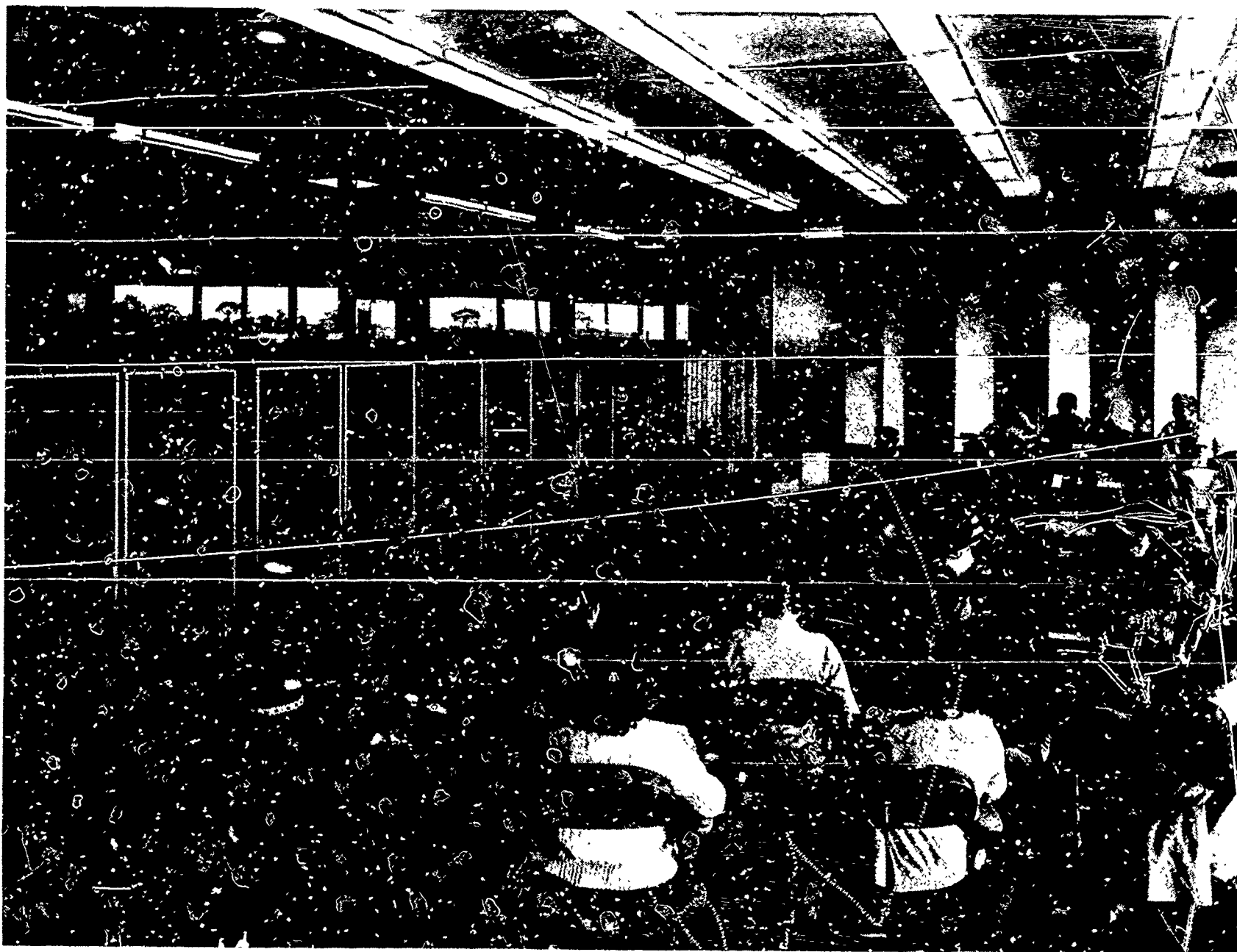

A room to be used for general music classes needs ample storage space.
Niagara-Wheatfield Senior High School, Sanborn, New York
The Perkins & Will Partnership, Architects

LISTENING FACILITIES

Several types of listening facilities are in common use in collegiate music schools today, and each presents specific planning problems. As independent study becomes more common in secondary schools some similar facilities will become desirable in the music department or in the school library. The principal systems include the following:

1. A number of soundproofed listening rooms or cubicles are each provided with a record player. The student receives phonorecordings from a central location (often the departmental office) and is his own operator.

2. A bank of record players or turntables is placed in a central control room. Work tables in an adjoining room are supplied with a number of receiving channels and sets of earphones. The student requests a particular re-

coding, which is played by the monitor in charge of the control room, and the student listens through earphones.

3. Tapes are made available to the student, who listens either in a cubicle as in (1) above, or in a central room (in which earphones are necessary).

4. Tapes are administered through a control room, as in (2) above, and the student listens through earphones.

The planning of a listening facility is dictated first of all by the kind of equipment the department uses, or the kind to which it wishes to change. The number of listening rooms or cubicles, the size of the control room and the number of channels available, the number of places at the worktables can be calculated by a method similar to that employed in the case of practice rooms. The design of the system, if methods (2) or (4) are used, must of course precede the planning of the area. Other than

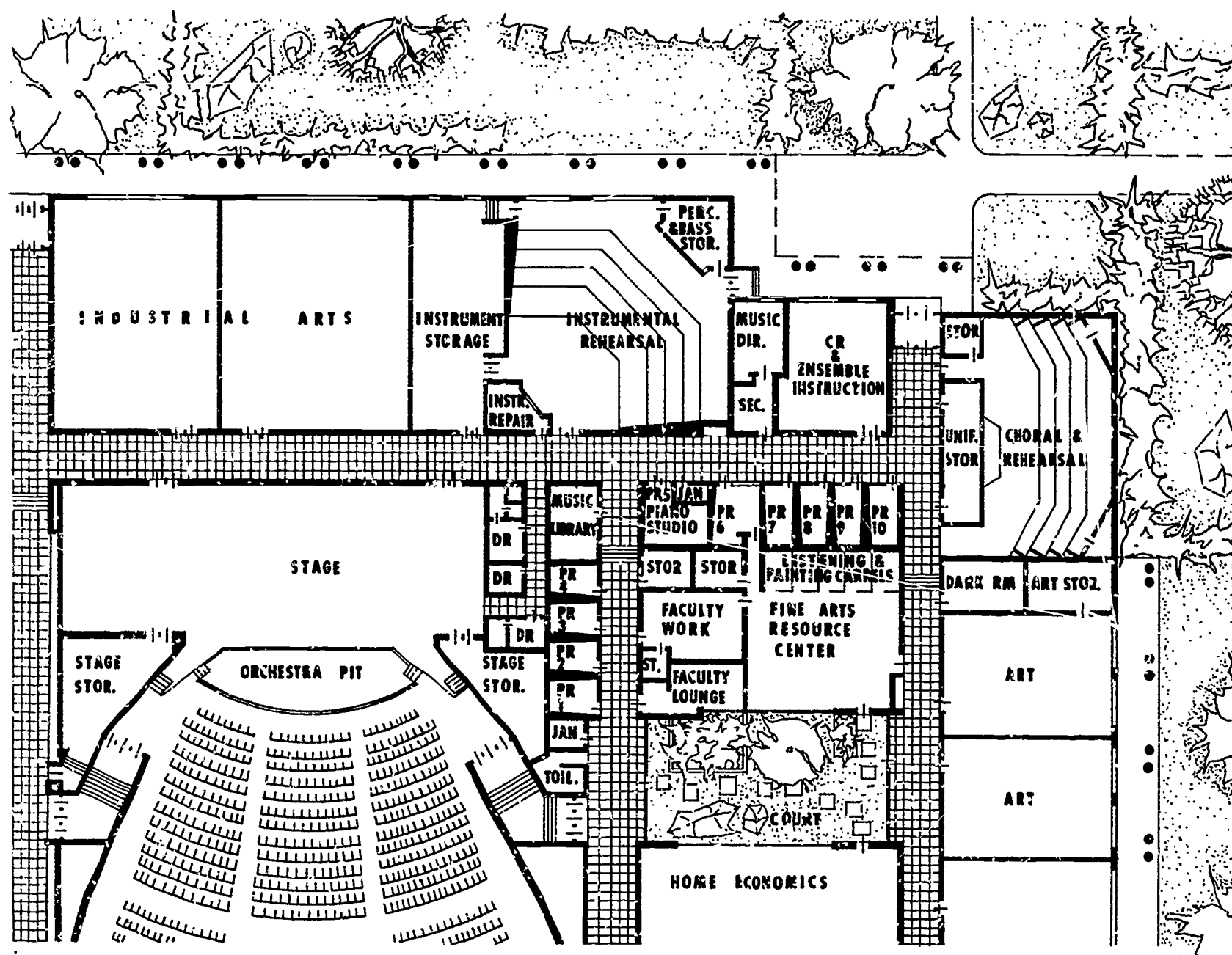

Listening facilities may be provided in a fine arts resource center with carrels being used for individual study in the various arts.
 Northport (New York) Senior High School
 Knappe and Johnson, Architects

providing for adequate space and convenient location in relationship to other music areas, no general observations will be needed in this section.

In many cases a college will set aside certain classrooms as theory laboratories. It may be desirable to provide cubicles in which students may work with individual tape recorders, phonorecords, or similar equipment. Certain storage and control requirements must also be planned in such situations.

STUDIOS

Traditionally much of the teaching of music has been done on a one-to-one basis. Though this country has

accomplished much through group instruction, it is still true that advanced instruction is almost always given to a single student. In colleges and conservatories this is carried on in studios which also serve as the faculty member's office. It is desirable also for schools to provide an office for each full-time music instructor. Most frequently it is located adjacent to the teacher's rehearsal hall and is provided with windows that enable him to keep an eye on ensemble rehearsals being conducted by students in the hall or in practice rooms.

In a college it is not difficult to determine the proper number of office-studios since the figure corresponds directly with the number of applied music teachers. More

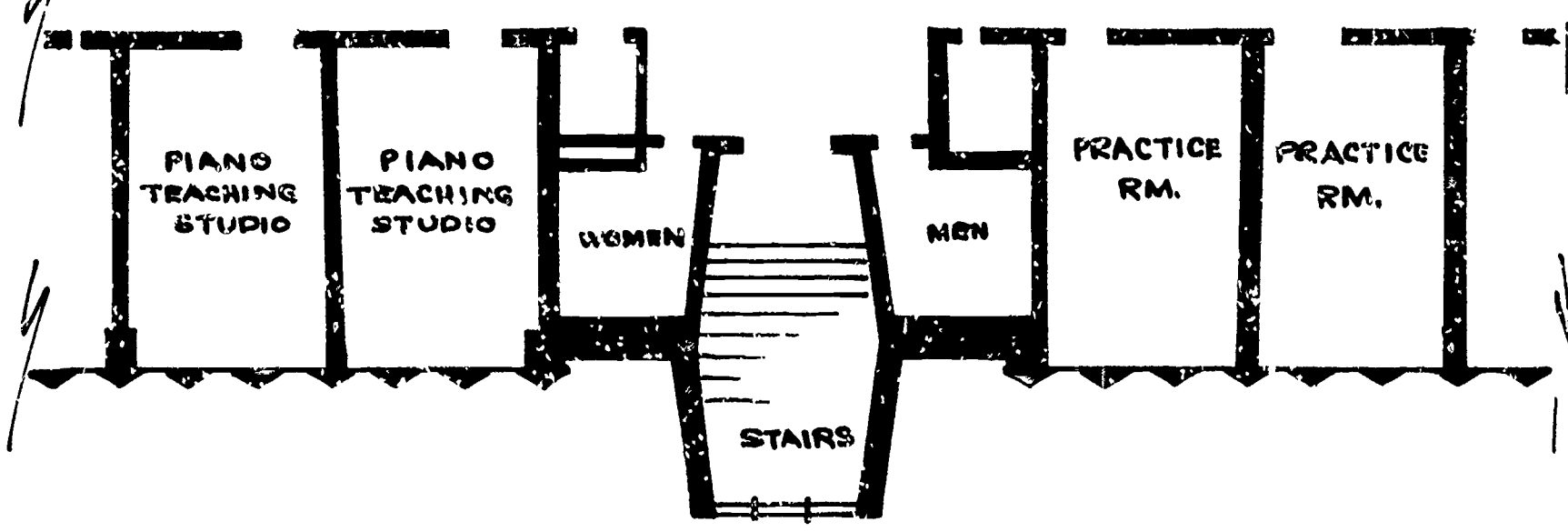
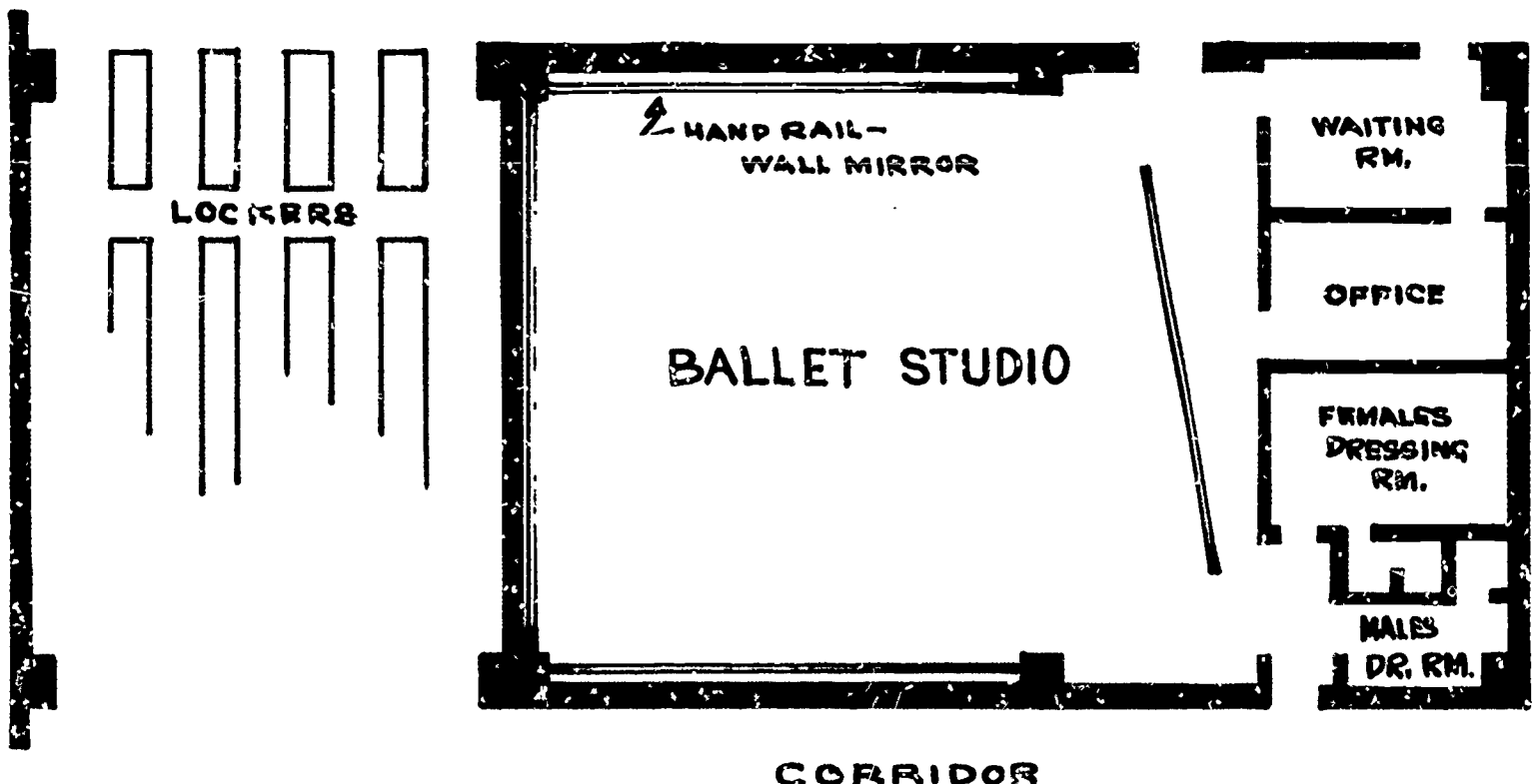
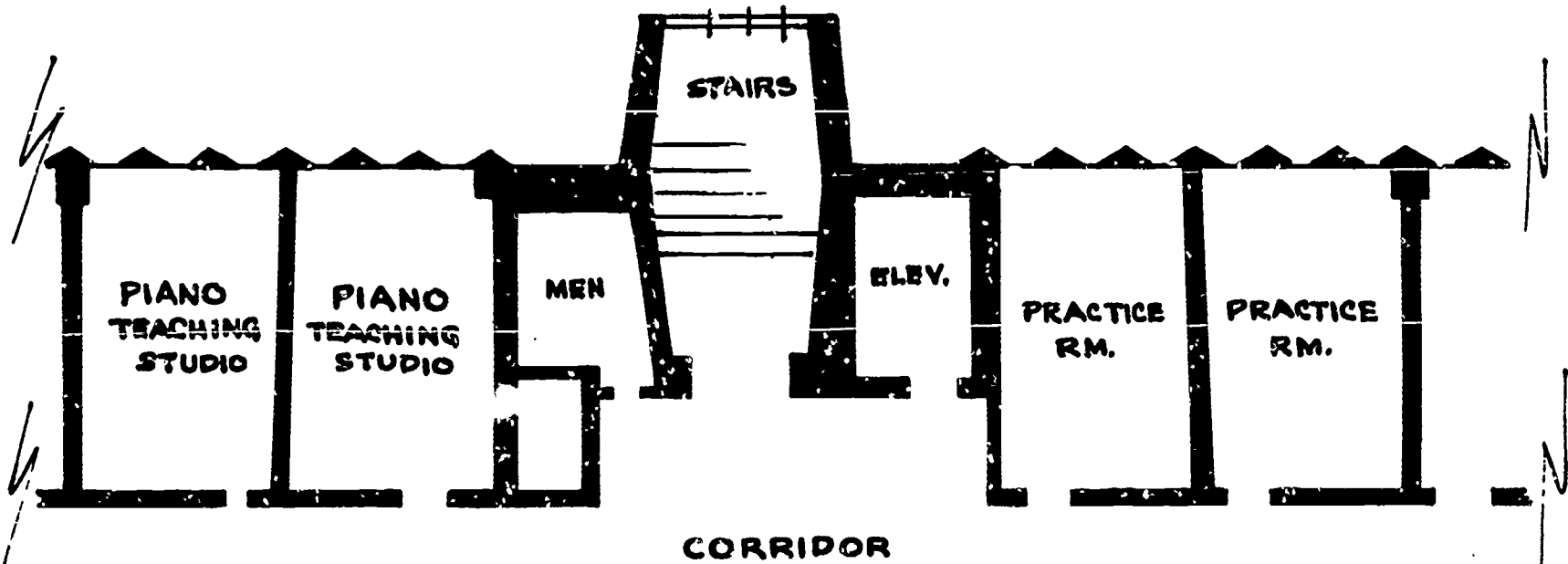

Provisions for instruction in dance may be included in some buildings.
College Conservatory of Music, University of Cincinnati
Edward J. Schulte and Associates Architects



Some studio-offices should be large enough to accommodate small ensemble rehearsals.
Tawes Fine Arts Center, University of Maryland
Henry Powell Hopkins and Associates, Architects

difficult is the matter of assuring the responsible authorities that space devoted to the studios will be fully used. A college instructor teaching applied music is likely to have a teaching schedule of 18 to 24 hours per week, and he will wish to do his own practicing and professional work in his studio. Occupancy of somewhere between 30 and 40 hours per week may thus be expected. Administrators may expect a 50 to 60 hour-per-week occupancy as they do in the case of classrooms and practice rooms. They may need help to see that an applied music teacher cannot work effectively if he has to share a studio.

Size.—The music teacher's office needs to be larger than a small practice room since he will have his desk and files there in all probability. There should be enough additional space for group lessons if he has the

need. Music files, instrument storage, and work areas frequented by students should not be in the office-studio.

College studios will vary in size with the instructor's specialty. Studios of the senior piano staff will ideally be large enough to accommodate two grand pianos and the usual office furniture of desk, file cabinets, and bookshelves. Studios of instructors of voice and other instruments, traditionally requiring only one piano, can be a bit smaller if acoustic conditions are otherwise met. Non-parallel walls are recommended but the studio should not be designed in such a way that piano placement and disposition of furniture is made difficult.

The size of the studio may also be determined by other duties of the faculty member. As an academic advisor he may need additional space for file cabinets; if he uses the

room for seminars he may require space for a table and chairs. In virtually all cases a small mounted chalkboard in each studio will be a valuable asset.

RECITAL HALL

A room intended for recitals or for performances by chamber music groups or small ensembles may be termed a recital hall. Anything larger falls into the category of theatre or auditorium and will be dealt with in Chapter V. Thus, planning the recital hall may well begin with a decision about the hall's intended use and its seating capacity. This will in turn influence the size of its stage and bring about certain limitations of use. A hall seating 250 people, say, can scarcely have a stage large enough to seat an orchestra and chorus, or even a large band. Schools may combine the idea of a recital hall or little theatre with the need for areas for large group instruction.

As in the case of other large special-use rooms, one may think of a recital hall as including several sub-areas also. Chief among these are performers' dressing room or rooms, provision for pipe-organ chambers (if the hall is to have an organ), recording or broadcasting control room, and box office. In each case, the location of these sub-areas should be considered in relation to ease of concert operation. For example, a control room should have a view of the entire stage, and performers' rooms should be located on the same floor as the stage rather than a floor above or below; otherwise both lose much of their convenience.

The seating capacity of the recital hall having been determined, its shape, proportions, etc., become matters for the architect. But a number of practical considerations, often overlooked even by experienced architects, may be listed here. For example, the lighting panel or dimmer panel should be located on the same side of the stage as the dressing room, for that is the side at which the stage manager will normally stand—in order to communicate with the performers. A bell or phone system should connect the backstage area with the box office, for efficiency in concert operation. Doors leading from the wings onto the stage must be wide enough to provide for the passage of a grand piano—a small detail, yet one that has often been missed. If delivery of pianos or other large equipment is anticipated, the stage should have access to a loading dock. And even if the music building caters primarily to campus audiences, provision for parking areas should be considered.

Even at the college level, the recital hall, as in the case of the large rehearsal rooms, will probably double as a classroom or large lecture hall at certain times. It

may be necessary, therefore, to provide theatre-type seats with folding tablet arms, so that the needs of both concert audience and note-taking students may be met. A large ceiling-mounted projection screen may be found desirable as well as connections to the recording studio. Some thought should be given to the location of a projector since a special projection booth is unlikely in a small recital hall.

FINE ARTS COMBINATIONS

Many schools are adopting the administrative policy of establishing Fine Arts departments and housing art, drama, and music in units separate from the classroom area. Buildings of this nature usually consist of a music complex, a drama complex, and a visual arts complex. Dance may sometimes be included.

The music complex has been described earlier. The drama complex consists of a small theatre with a capacity of 300 to 500, work room, dressing areas, one or more classrooms, storage rooms, radio-television control and listening areas, costume storage and work area, and library.

The complexity of these constructions requires the selection of an architect who has specialized in theatre construction, and an acoustical consultant to work with the architect from the initial planning, through construction to completion. Only through this method of team planning can a school be assured of quality construction and satisfactory results. References of interest

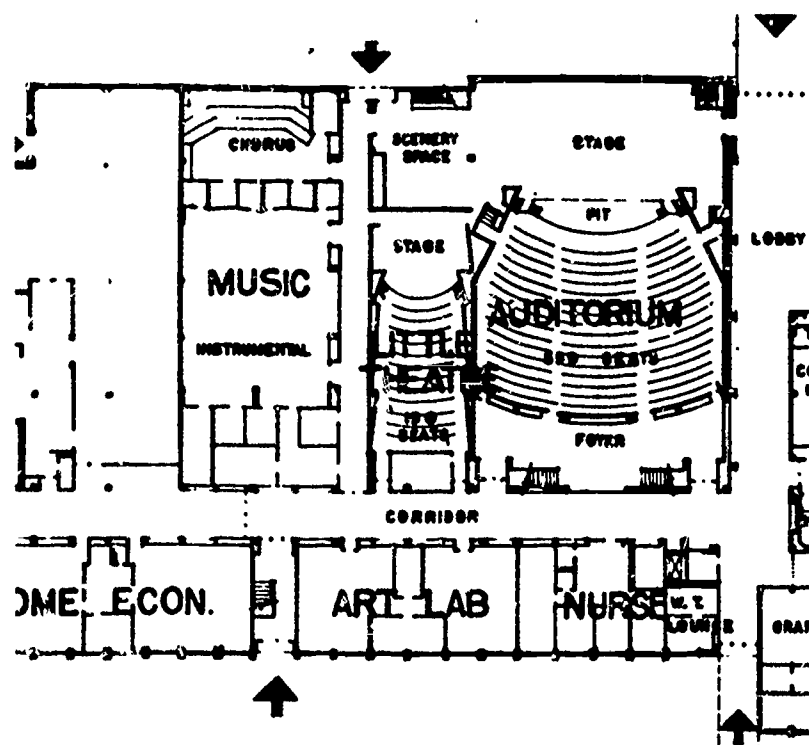

Schools may combine the idea of a recital hall or little theatre with the need for areas for large group instruction.
Hinsdale (Illinois) South High School
Fugard, Burt, Wilkinson & Orth, Architects

in this area include *Better Architecture for the Performing Arts*¹ and *Theatre Design and Technology*, the Journal of the U. S. Institute for Theatre Technology.²

The art complex consists of classrooms, laboratories, offices, museums and display area, library, storage, offices and facilities for security personnel. The size and extent of these units depends upon the school size, community needs, and teacher orientation. In some schools and areas of the country, this department of the Fine Arts is experiencing the most rapid growth in history. With the general public showing an ever-growing interest in art, it is important that schools assume a place of leadership in fostering the development of the visual arts. In planning the visual arts areas, one should not overlook photography laboratories, sculpture classrooms, shops for various crafts, and other forms of arts and crafts indigenous to local communities. Obviously, graphic arts teachers will be involved in planning but music educators and administrators might find *Space and Facilities for Art Instruction*³ helpful.

Another aspect of the music-drama-art complex is that of combined festivals which frequently extend over several weeks of activity. These productions require highly specialized facilities which may result in total community effort. Seldom is there sufficient space provided for such musical extravaganzas as symphonic drama, dance-drama, ballet, and historical revues. Many

¹ "Better Architecture for the Performing Arts." *Architectural Record*, 136 (December 1964), 115-142.

² *Theatre Design and Technology*. Journal of the U. S. Institute of Theatre Technology, 4200 5th Avenue, Pittsburgh, Pennsylvania, 15213.

³ U.S. Department of Health, Education and Welfare. *Space and Facilities for Art Instruction*. Special Publication No. 9. Washington: U.S. Government Printing Office, 1963.



Provision for a pipe organ may be a requirement in some recital halls.

Warner Concert Hall, Oberlin College Conservatory of Music
Minoru Yamasaki and Associates, Architects

of these need highly individualized and specialized facilities requiring architectural, acoustical, and engineering consultants who have given considerable time to research and study. In securing such consultants it is most important that the builders investigate the musical and dramatic background of those who are to advise on construction.

Special Uses of Fine Arts Facilities.—In recent years there has been a strong trend for increased emphasis on education from the kindergarten through adulthood. This emphasis on a wider age spread had been evidenced by the change in college enrollments. No longer can the term "college age" have a specific meaning as it once did. Today, people of all ages are attending colleges and secondary schools—entire families are going to school, from the youngest in nursery classes to the fathers in graduate seminars. This changing picture of education demands a more efficient use of buildings and facilities. In colleges, recital halls and auditoriums are being used a high percentage of the day. In some schools these rooms are in use for either rehearsal or performance from early morning to late evening. Large rehearsal rooms are in use a similar amount of time. In public schools these same facilities are used for adult evening classes, conferences, lecture rooms, and other community functions. For economy and efficiency, schools should consider these eventualities in planning the fine arts facilities.

Undesirable combinations.—Schools in the past have planned various combination facilities which involved music rooms supposedly in the interests of economy. These have included combinations of auditorium stage and music room, gymnasium-auditorium-music room, gymnasium-music room, and cafetorium. All of these must be viewed as undesirable. Few of the activities that would be carried on in such facilities have the same requirements. A gymnasium that is treated acoustically to achieve the reverberation period and noise level required for music would have a depressing effect on athletic activities. A cafetorium that would provide the room height necessary for instrumental music could result in only nominal savings at best.

Unless educational opportunities are offered in such a manner as to give the student the best learning situation, there are no savings. He must achieve the most for his efforts and learn to do his tasks in the best possible manner. Makeshift, make-do, unfortunate substitutions and wrong tools are a poor approach toward the attainment of the ideal of American education. Economies must not be made at the expense of the student and good planning by educators and professional architects should make such practices unnecessary.

AUXILIARY AREAS

STORAGE AREAS

Adequate storage areas, planned with traffic patterns in mind, are important to the proper functioning of a music facility. Storage, with proper heat and humidity control, is necessary for musical instruments, robes and uniforms, music, records, and various types of equipment. With careful planning the storage areas can be conveniently placed and at the same time serve as a buffer between two sound-producing areas such as the instrumental and choral rehearsal halls.

Instrument storage.—Instrument storage facilities should be located so as to minimize the moving of instruments. Sufficient free floor space should be provided to permit smooth flow of traffic. Storage cabinets located within the rehearsal areas are inaccessible during rehearsal periods and frequently cause congestion during period changes.

An instrument storage room should be at least 20 ft. wide and 30 ft. long. If there are to be windows, they should be placed high along one side. Glass block construction is frequently employed here. This type of win-

dow placement will permit the use of cabinets below the windows. Cabinets of various depths to care for the various musical instruments to be stored can be placed along two or three of the walls. Making cabinets all the same width and height will give a pleasing appearance in the room. The size of cabinets should be no more than a maximum of 48 in. in depth, 62 in. wide, and 83 in. high, including toe space.

In some instances it might be advantageous to extend cabinets to the ceiling or have another set of cabinets built and set upon the lower group for storage of equipment used only once or twice a year. A special stepladder should be kept on hand for reaching this high shelving or locker space. Storage units can be built in by the building contractor or purchased separately. Where pre-built units are used, care must be taken to make sure that large units can pass through the door openings.

This room should be well ventilated or protected against excessive moisture, heat, or extreme changes in temperature, inasmuch as many musical instruments are made of wood with glued joints. While some schools provide only shelves for storing instruments, this practice is considered unsatisfactory since most instruments have removable parts which are easily broken or jarred loose, and they may be lost or stolen when instruments are not kept in compartments. The instrument storage room should connect directly with the instrumental music room.

Wood instrument lockers built to specifications for musical instrument storage are available from manufacturers of school storage equipment. Some schools prefer to use metal storage cabinets. If metal is used, it is recommended that felt be affixed to the bottom of the cabinets. This cuts down the noise and the possibility of damage to the instruments. Ventilation space should be provided in each door. Care should be taken to make the compartments large enough to avoid hitting the door edges when removing the instruments. Folding doors built to extend over several cabinet fronts are another method of protection of instruments.

Lockers for the instruments should be constructed to promote ready use as well as to protect the instruments. Some schools may prefer to construct deep lockers into the wall area of surrounding corridors. The shelves and compartments should be "tailor-made" to suit the instrumental and equipment needs. A maximum depth of 4 ft. and a height of 6 ft. would be adequate for these wall closets. Since most of the smaller musical instruments can be kept in the regular student lockers, it may not be

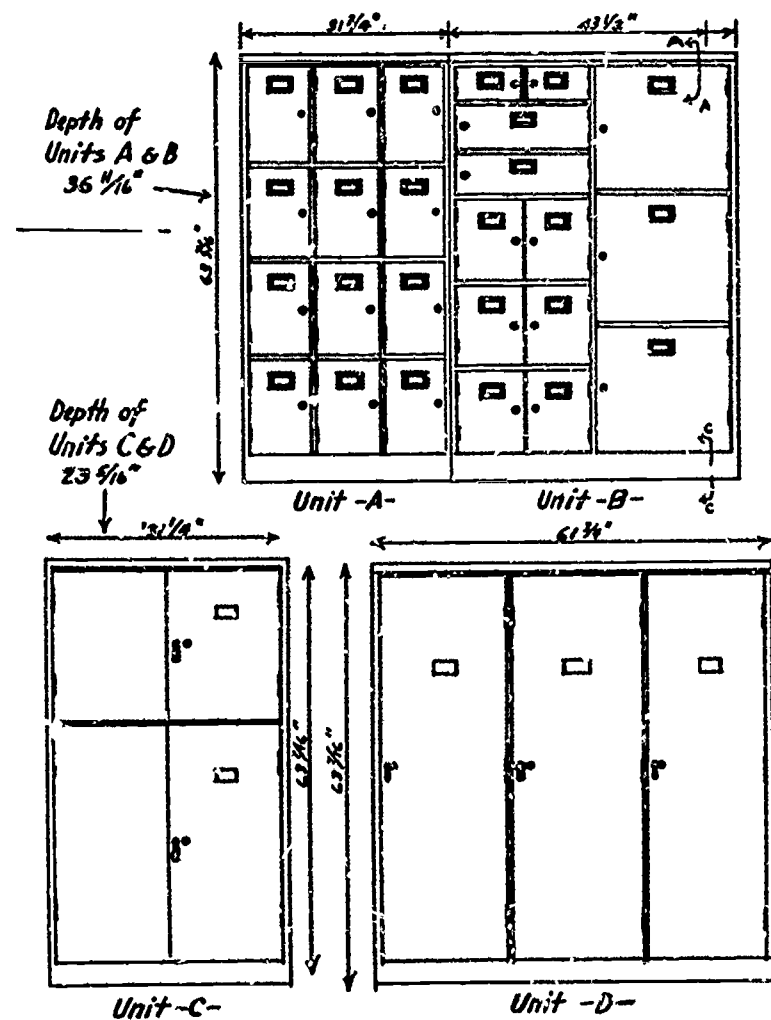

Compartments should be "tailor-made" to suit the instrumental and equipment needs.
Plans from Board of Education, Pittsburgh, Pennsylvania

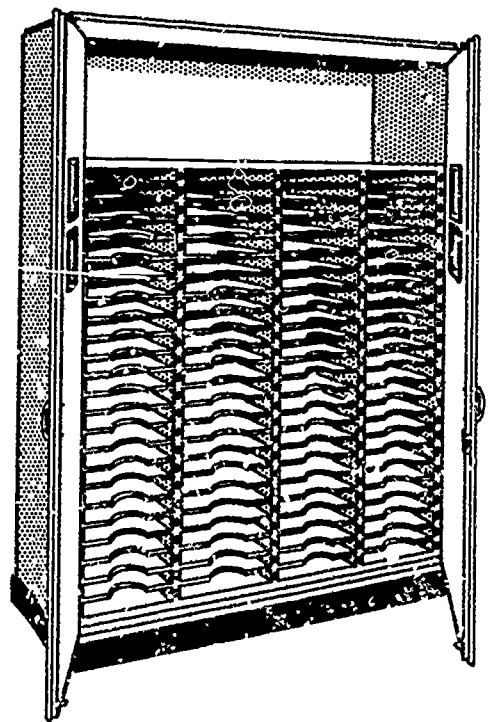
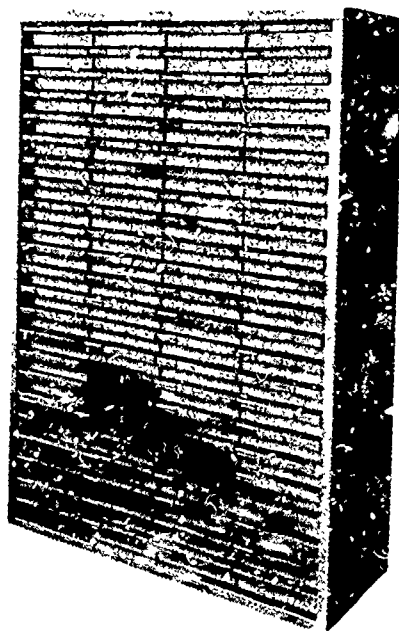
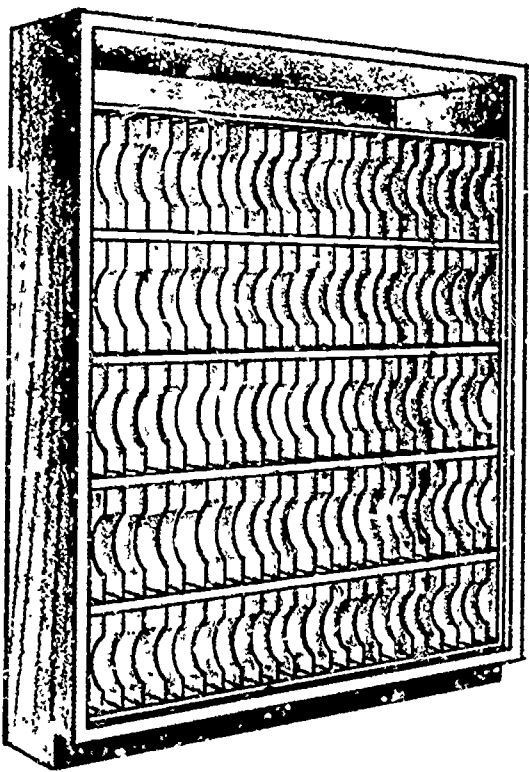
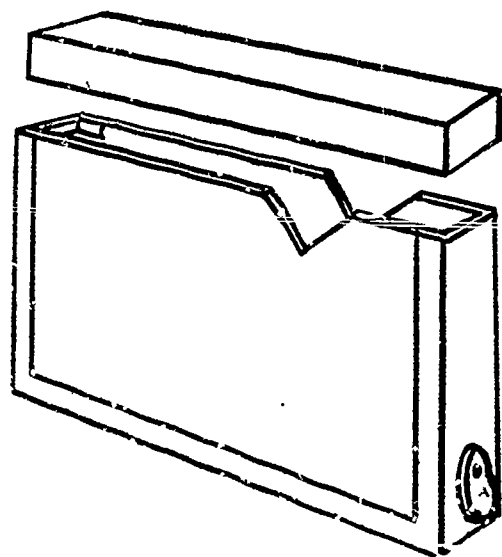
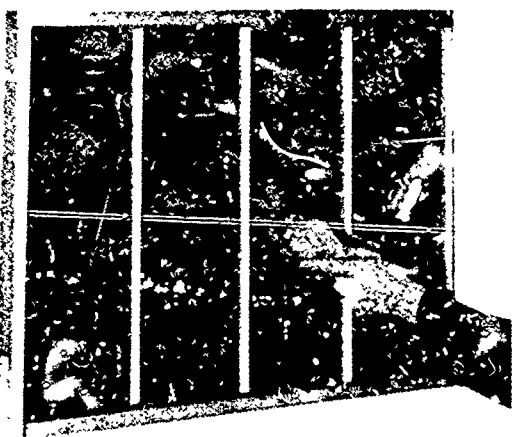
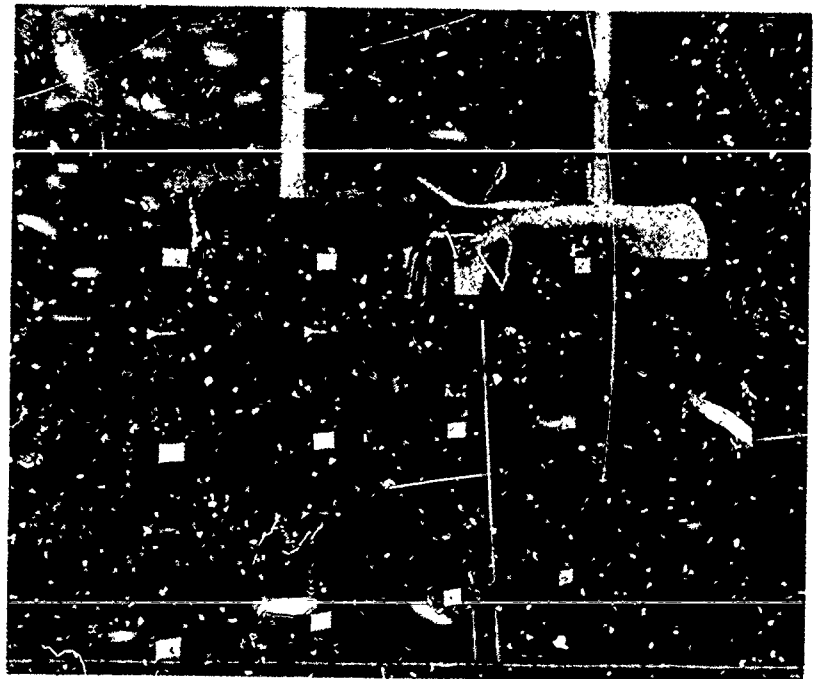
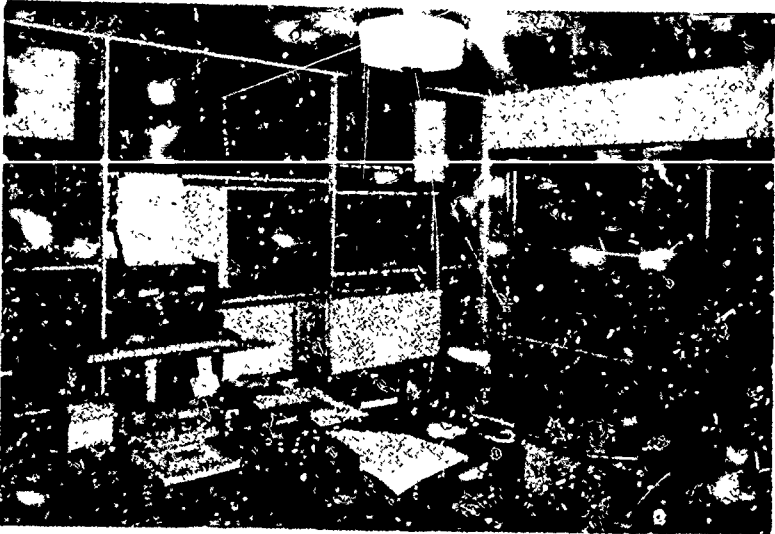

Storage cabinets of many types are available for music libraries.

MUSIC LIBRARY

necessary to build specially designed compartments for them. When these smaller instruments are not assigned to the students (i.e., summer vacation period), several instruments can be stored in the larger compartments. Felt or rubberized linings should be placed on the compartments which store the large, uncased brass instruments.

Uniform and robe storage.—Storage facilities should be planned for the school-owned band and orchestra uniforms, choir robes, or vestments. This closet space should be cedar-lined. A well-constructed, close-fitting door will help protect against moths and dust. The closet space should be high enough so that the uniforms and robes will not touch the floor when hanging on the racks. Some provision should be made to space the uniforms and robes at equal intervals and to facilitate identification. A separate (pigeonhole) compartment for the caps, belts, and other miscellaneous equipment should also be provided.

Some schools require the band and choral uniforms to be left at school. Where this is done, provision should be made for dressing facilities located near the uniform storage. The dressing rooms should be provided with bathing facilities, mirrors, and adequate dressing space. In some schools these are rather elaborate facilities; in others, only minimum space is provided in the restrooms. A Texas high school provides a uniform workroom equipped with sewing machines and personnel to alter and repair uniforms. Such a room may also be used as a workshop for making minor repairs on the instruments. To facilitate distribution of equipment, a shelf on the lower half of a Dutch door is recommended for the instrument and uniform storage rooms.

Music libraries will range from a single set of filing cabinets in the music room to the school of music library complete with stacks, reading rooms, charging desk, listening facilities, and work areas. In most colleges there will also be smaller libraries (band, orchestra, choral) which are more like the school situations described here.

Steel filing cabinets (full suspension, with thumb locks) are frequently used for storing vocal and instrumental music. The letter-size file is satisfactory for choral music, whereas the legal-size is desirable for most of the band and orchestra compositions. Many schools are using specially constructed cardboard boxes for their music. This plan does not use as much floor space and makes it possible to store the same amount of music by using more wall space. This box storage also makes it possible to add new numbers in their proper places without shifting whole file drawers of music to make space for the new purchases. Also available are storage units designed like the old parlor music cabinet which makes it possible to store the music flat.

A sorting rack with five or six slanted shelves is valuable for distributing and arranging music for the individual music folders; it can also serve as a folder cabinet. Many music directors prefer a specially constructed music folder cabinet which has individual pigeonhole compartments for each folio. This cabinet keeps the music orderly, facilitates passing and collecting the music, makes a quick check possible on what music has been removed for individual practice, and also provides a convenient way of carrying the music from the rehearsal area

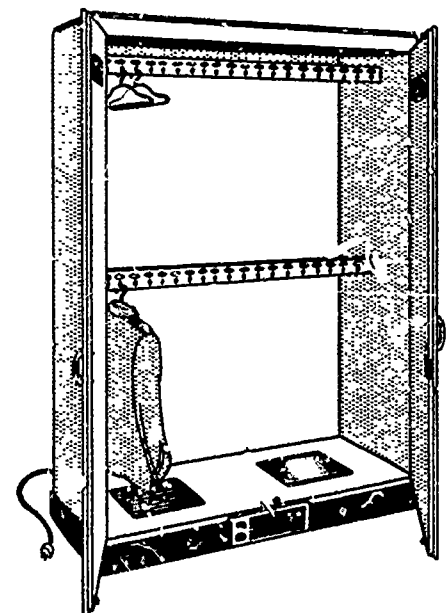
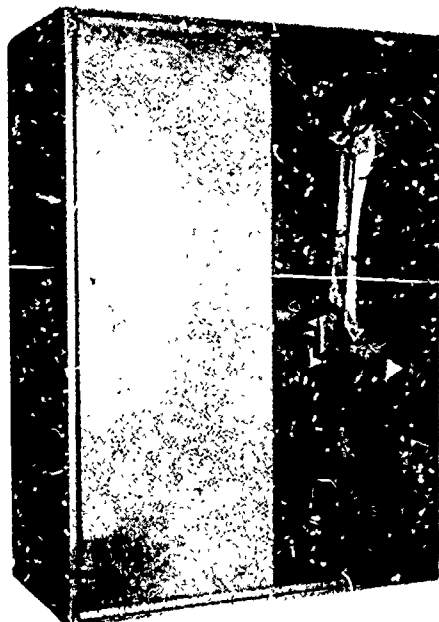

Closet dimensions should permit robes and uniforms to hang freely without touching the floor.

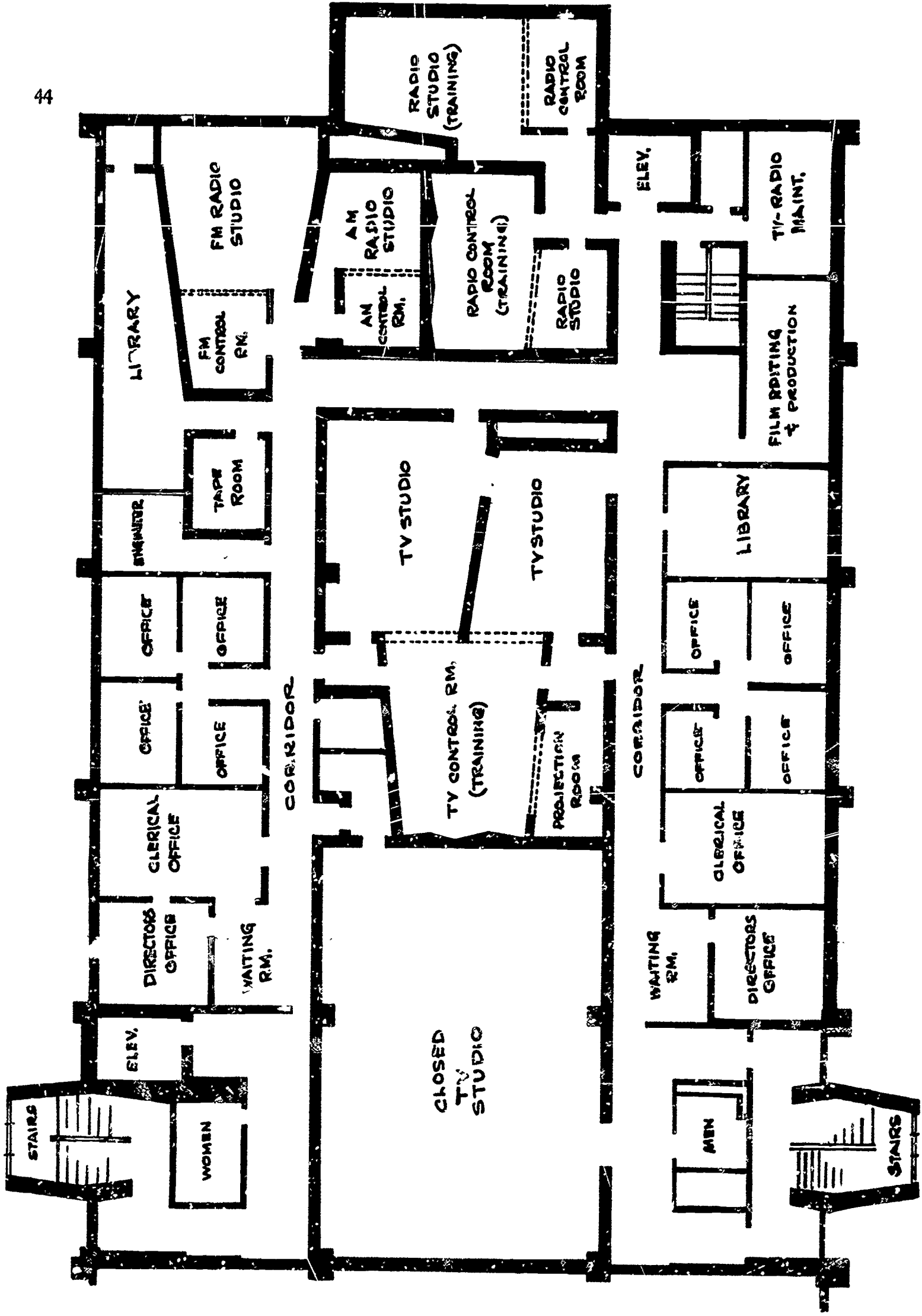

The recent improvements in recording equipment and television education have resulted in facilities to make use of these new techniques.
 College Conservatory of Music, University of Cincinnati
 Edward J. Schulte and Associates, Architects

to the concert stage. The partitions should have semi-circular recesses so that the folders can be easily grasped.

The music library room should be separated from the instrument storage room. However, it is usually desirable and practical to have the two rooms adjoining, both opening off the music room or stage, or both. Space must be provided for work tables, supply cabinets, chairs, and desk. In many smaller schools the music library equipment is kept in the music director's office.

WORKROOMS

Instrument Repair.—Some sort of facility should be provided for emergency instrument repairs. A special room is recommended although many schools will use a section of the music library room or director's office for this purpose. Larger school systems will employ specially trained men to take care of all instrument and equipment repairs. The minimum provision should be a workbench, stool, and a supply of tools for repairs. Cabinet space with small drawers should be provided to hold pads, pad cement, springs, cork, and other miscellaneous equipment. If a great deal of repair work is done in the school, the workbench should have a gas connection, electrical outlets, wood and steel vises, and other specialized equipment. Running water and a large sink for cleaning brass instruments should be included.

Duplicating Room.—School music departments will have the facilities of the general office at their disposal in most cases and may not need duplicating equipment in the music suite itself. Most collegiate departments or schools of music and some school departments housed separately in a campus type school will find a duplicating room invaluable. There are many times when the music department needs items copied—rehearsal schedules, instrumental parts of a student composition, football show routines, trip itineraries, vocalizes for the choir, songs in the public domain—that equipment should be readily available. The room should include counterspace enough for several types of machines, space for collating, and a sink.

Offices.—A music program that functions smoothly should provide a well-located director's office. Examination of plans of music suites included in this volume will provide ideas as to location in relation to the other areas of the department. The size and equipment included in the office will depend on the size and organization of the school. The room need not be especially large unless it is also to serve as a studio in which small group instruction may be carried on. It should, however, be able to accommodate a desk, two or three chairs, filing cabinets for correspondence, cabinets for miscellaneous storage,

and any special equipment such as electronic tuners, piano, phonograph, radio, and tape recorder.

Music teachers who teach in several locations in a school (e.g., harmony in a classroom, choir in the recital hall, general music in a specially equipped center) need an office to organize the many materials and instruments, and pieces of equipment with which they work. Offices are also essential for the department head or the director of performing groups because of the frequent contact they have with members of the community.

The central offices of a collegiate department or school of music will reflect the unique organization and function of the particular department. If the offices provide only for administrator and secretarial staff, one size is indicated; if, in addition, the office area houses advisors, student records, and the like, a more complex unit will be required.

The service area for the central office may range from merely a closet for supplies to a well-equipped room with several types of duplicating machines. It may include a check-out space for phonorecordings and be adjacent to listening rooms; it may also provide a repository for the department's audiovisual equipment. If student inquiries are anticipated in large number, a counter may be planned in the office. This has the advantage of controlling office traffic to a large extent, separating the office personnel from the "public" and also providing space (under the counter) for office supply storage. Thus, the services performed by the office personnel, their availability to faculty and students, the traffic patterns likely to develop from the office's relative location are all factors in the planning of a departmental office.

BROADCAST CONTROL BOOTH

The recent improvements in recording equipment and television education have resulted in many schools being constructed with facilities to make possible the use of these new techniques. Educational programs of all types are made available to the school and community; therefore, school space should be allowed for both receiving and broadcasting of music. The control booth should be well insulated for sound and should have slanted double glass windows for viewing the performing groups. A control booth is sometimes located adjacent to the stage of the auditorium or recital hall and sometimes between the rehearsal halls.

ADDITIONAL FACILITIES

Washroom and Toilet Facilities.—Because the music suite is frequently used at night when the remainder of the building is locked, washroom, toilet facilities, and

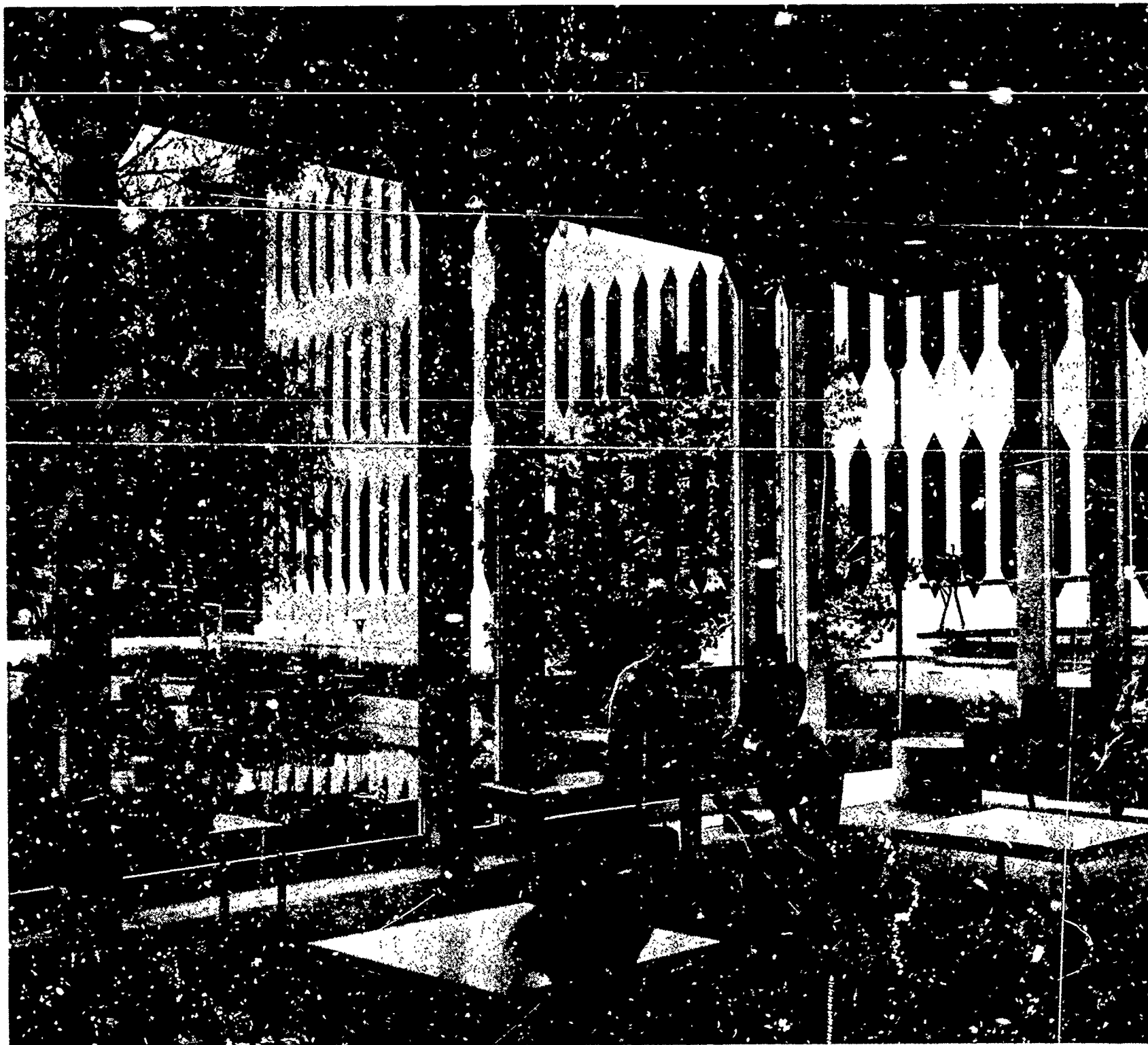

Collegiate music departments may need to consider the desirability of a student lounge.

*William E. Stevenson Lounge
Oberlin College Conservatory of Music
Minoru Yamasaki and Associates, Architects*

custodial work areas must be provided within the music unit. In many instances they may be necessary for the changing of uniforms and must be convenient to the rest of the department. These facilities require about 15 percent of the total floor space if adequate room is to be provided. If recitals to which the public is invited are given within the music unit, possible additional rest room space will be needed.

Lounge.—Collegiate music departments may need to consider the desirability of a lounge in which students

can relax. If other study areas on the campus are some distance from the music facilities, one portion of the lounge might provide desk or table space. An area might also be provided for vending machines.

Elevator.—Because of the heavy instruments and equipment which it is frequently necessary to move in a music department, an elevator is a most desirable feature in a building of two or more floors. Also recommended is a loading dock adjacent to the parking area.

The Auditorium

THERE ARE MANY school facilities in the planning and construction stage at the present time. It is frightening to consider the amount of money that could be wasted upon improperly designed facilities in those buildings, upon facilities that are not suited for their particular situations, or upon facilities that are designed to suit specific situations that are not appropriate to their particular communities. An auditorium should be designed so that the activities can be maintained and operated with a minimum of time and labor consumed in the preparation of an event. In schools, this area is being designed for education, not commercial purposes. Architects with experience in designing neighborhood motion picture theatres are not necessarily prepared to solve the problems associated with school auditoriums. The faults of previous facilities and of other situations should be taken into consideration but these should not be allowed to be the guiding design factor. They may not apply to the new plan.

The school administrator or teacher is seldom a trained engineer nor is the architect an experienced educator. The wise school administrator will consult the music department, both instrumental and vocal, the dramatic department, and all other groups in his school and community that will use the proposed auditorium. Teachers should present their requirements to the lighting engineer, the acoustical engineer, the ventilating engineer, and the other consultants. These engineers should then, using this information, present their special design re-

quirements to the architect. The architect in turn must incorporate in plans and specifications those features needed for the various specialized purposes. It is not enough merely to incorporate these various designs on the drafting board, but it should be the responsibility of the school teacher and the school administrator to see that the various engineers follow up their proposals, and that the suggestions are satisfactorily incorporated in the design of the auditorium. The job should be watched to see that the proposals are carried out, and to make sure that the contractor incorporates these special features and requirements in the actual construction.

Many school boards and school men make extensive tours, viewing other school plants. These tours are extremely valuable and educational, and from them the school men should glean many new and startling innovations. To use the phrase often used in various industrial suggestion systems: "There is always a better way." Is this better way the best way for your particular situation? A school must not be handicapped with an inadequate, improperly planned auditorium. Maybe it would not be practical and economically possible to have all the items desired, but they can be incorporated in the plan so that if the opportunity presents itself these items may be added without undue structural changes.

The information supplied here applies to many specific situations, but does not represent an effort to set forth hard and fast rules. The items discussed in the following paragraphs are not complete, but are intended as a checklist pointing out some of the major items to consider in the design of the school auditorium.

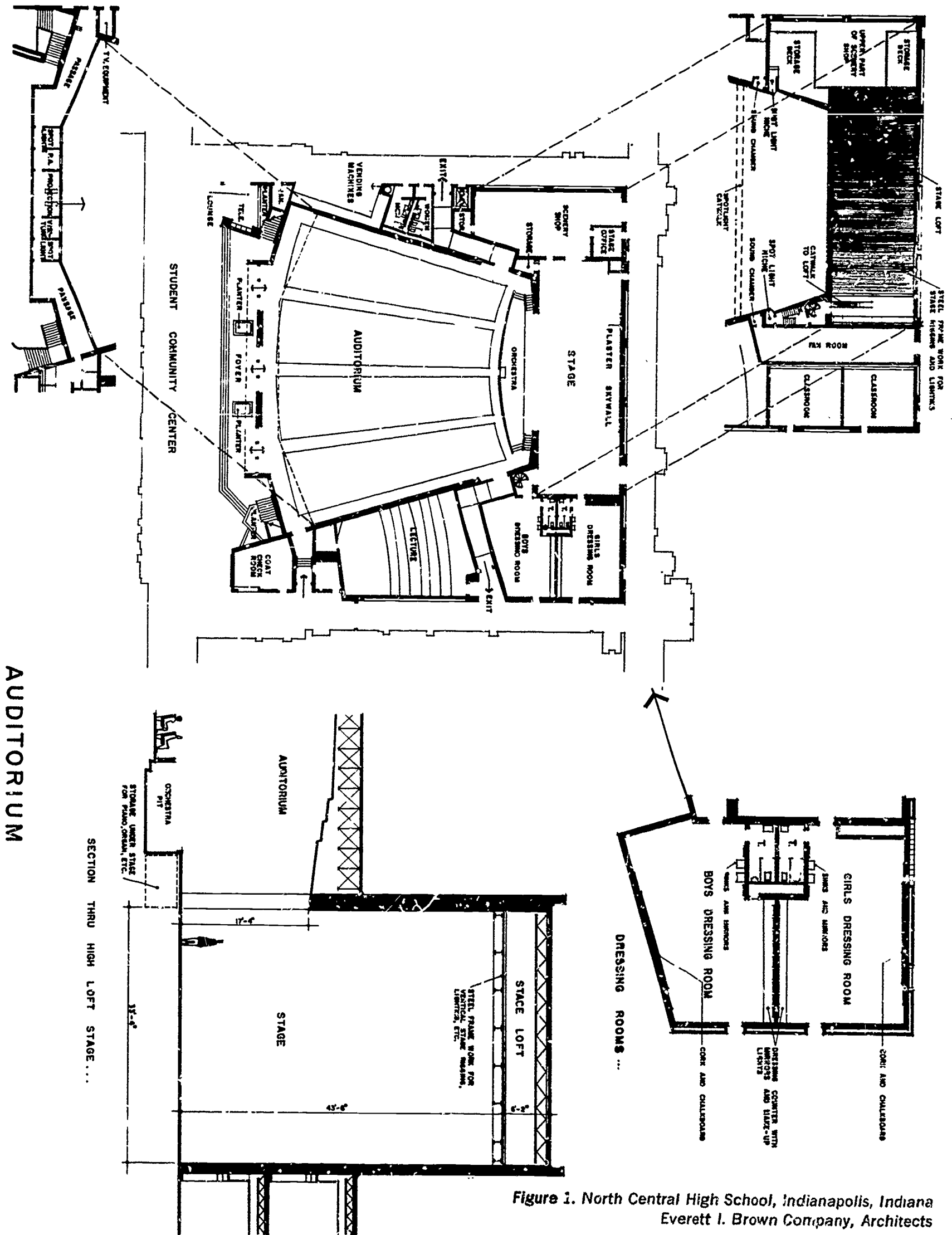

Figure 1. North Central High School, Indianapolis, Indiana
Everett I. Brown Company, Architects

STAGE

The stage is considered first because it is the part of the auditorium most frequently abused by the designers.

The proscenium arch size is dependent upon several factors—the size of the auditorium, the playing area of the stage, the height of the stage loft or grid (Figure 1), the size of the community using the auditorium, and the seating capacity of the auditorium. For general purposes, the proscenium arch should not exceed 65 or 70 ft. in width and the height of the auditorium should be in practical or artistic proportion to the width. This height is an important factor that will determine the location of the grid. The grid will be the subject of a separate discussion. All of these items are interrelated, and the architect must consider all of them and their interrelationships.

The playing size of the stage will be determined by the sizes of the musical organizations, the stage requirements of musical or dramatic productions, and the scope of other activities proposed for this stage. Clarence J. Best recommended in his survey that an orchestra player be allotted 18 sq. ft. of floor space for himself, his instrument, and his music stand. This is a generally accepted figure for the minimum seating area and is much less than recommended for the rehearsal hall because the space needed at the front of such a room need not be figured here. A 100-piece orchestra would require about 1,800 sq. ft. of floor space, or an area about 50 ft. wide and 36 ft. deep. For practical purposes the requirements for band are about the same. The stage will have to be proportionately larger if the instructor is planning to rehearse and use combined choral and orchestral groups. This is the type of information the music educator must supply to the architect.

The stage area of 1,800 sq. ft. mentioned above merely refers to that part of the stage visible to the audience and usable inside the shell or legs. The off-stage area is often overlooked, yet it is a very important functional part of the stage. In presenting concerts, operettas, and plays, some off-stage area is necessary to handle personnel, scenery, and equipment. These areas are often too small. The left and right off-stage areas should each be approximately one-half the size of the stage plus 10 percent. In addition, there must also be sufficient off-stage area for the pin rail (Figure 3), switchboard, and similar permanent features. A large proscenium opening can always be made smaller through the use of curtains, flats, teasers, etc. If the major architectural construction is too small, increasing the size of the proscenium is very difficult.

A good proportion to follow in determining the depth of the stage is that the depth should be 75 percent of the

width of the proscenium arch, and this depth area should continue on both sides of the stage. To use simple figures, if the proscenium arch is 48 ft. the depth of the stage should be 36 ft. The off-stage areas would be approximately 27 ft. wide and plus that additional space necessary for permanent equipment on the right hand side. Both off-stage areas would be 36 ft. deep. This off-stage area could handle stage wagons that would cover the entire playing stage. It would be of sufficient size to store a number of stage sets for musical and dramatic performances. A trap in the stage floor is handy for moving equipment from work areas below and makes possible special effects in dramatic productions (see Figure 2).

The off-stage areas should be readily accessible to adequate dressing room space. There should be adequate space close to the stage to take care of lighting machines, lighting cables, repair and supply parts, and storage for curtains and other stage equipment. In all educational situations it is practical to have the rehearsal rooms for chorus, orchestra, and band in close proximity to the stage in order to facilitate the preparation for rehearsals, concerts, and recitals.



Figure 2. Thornton Township High School, Harvey, Illinois
Jos. C. Llewellyn, Co., Architects

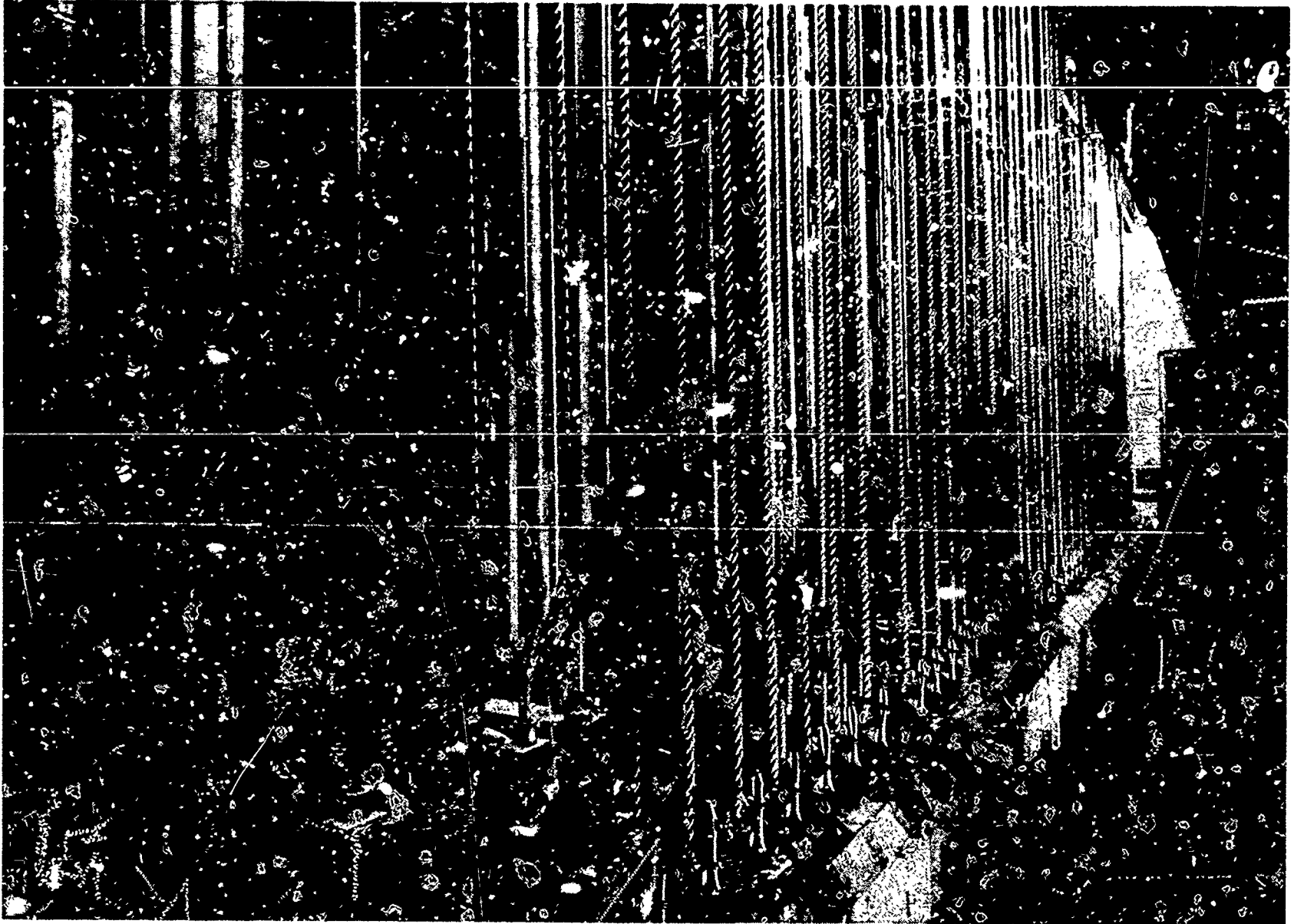

Figure 3.

The instrumental storage rooms, library rooms, scenic shops (including painting racks), and construction areas should be close enough so that properties can be shifted onto the stage with a minimum of effort and damage.

APRON

The floor area in front of the proscenium arch is called the stage apron. This apron should be at least 8 ft. wide so that pianos and other equipment may be used in front of the main curtain. The apron may extend out over the orchestra pit. The front of the apron should be finished with a hard oak or maple flooring, and that part in back of the proscenium should have close-grained pine in order that the floor will not splinter and yet will be soft enough to take stage screws. Much money has been wasted on hardwood floors for school stages, to the extreme exasperation of stage directors and their crew. The oak or maple floor should be finished with a high gloss but not waxed, and the pine floor should be finished with many coats of oil and the oil allowed to penetrate the wood

thoroughly so that it will be fairly seasoned. On both sides of the stage leading from the auditorium to the stage apron there should be appropriate steps. These steps should be wide enough to enable personnel to carry musical instruments and other small properties and from the auditorium to the stage, or so that the students may approach the stage at least two abreast.

GRID

One of the paramount faults committed in designing school auditoriums is the fact that the grid over the stage is not high enough for the scenery to be pulled out of sight. The grid should be at least the height of the proscenium arch times two plus a minimum of 8 ft. Then there should be from 4 to 7 ft. above the grid to the top of the building structure, so that the people who find it necessary to work on the grid, changing pulleys, etc., will have sufficient room. The overall height must be sufficient to make it feasible to hang scenery and pull it out of sight in changing sets.

Often when there is no space overhead and scenery must be pulled into the wings of the stage there is also not enough space to stack this scenery off stage. Thus the only solution is to make the stage smaller, masking out with drapes or flats and reducing the proscenium arch so that the stage is much narrower. Then the stage crews will have to work behind the drapes as a backstage area. *If dramatic productions are anticipated space should be provided for a grid.*

One not too familiar with stage operations or requirements often finds the grid an ideal place to run ventilating pipes, conduits, steam lines, and water pipes. Just because this large grid area presents a wide open space, it is a tempting area for various trades; however, this area must be kept entirely free for the necessary stage equipment. Nothing is more distressing than to have guide ropes fouled among ventilating ducts, or to have steam pipes leak in the center of a stage set during a performance or concert.

BATTENS

A proper stage will have a number of battens suspended from the grid. These battens are long pieces of pipe extending the full width of the stage and continuing backstage so the curtains and legs may be hung backstage in order to mask off this area from the view of the audience. Battens are part of the permanent fixtures of a stage. The common way to counterbalance the battens is through installation of a pin rail (see Figure 3). The standard counterbalancing equipment as supplied by the major manufacturers of stage equipment is usually satisfactory. Makeshift installations should be avoided. Battens should be placed six inches apart. There never seem to be enough pipe battens to take care of the stage needs. All the lights, border lights, teasers, a border in front of each strip light, three or four legs on each side, the front curtain, oleo curtain, back drops, and sky drops are all standard pieces of equipment that are hung from battens. By the time a light batten or light bridge is added at the fore part of the stage and sufficient battens are provided for scenery changes, it is not at all unusual to use about 25 or 30 battens.

CYCLORAMA

Most stages require a cyclorama and a set of cyclorama lights. This cyclorama should not be confused as a substitute for a stage shell. A cyclorama is usually a continuous curtain starting close to the proscenium arch on one side of the stage. It extends to the rear of the stage, across the back of the stage, and comes forward, ending close to the other side of the proscenium arch.

SHELL

Every stage must be equipped with an adequate shell. For lectures, concerts, and recitals on theatre stages, the purpose of a shell is to project the sound into the auditorium. This shell should not attempt to use border lights for lighting but should have lights installed in each section of the ceiling so that the stage will be flooded with about 60 to 70 footcandles of lighting. The lights should be arranged so that the back row will have sufficient light, and so that the lights will not throw a glare back into the audience. The shell should be made the full width of the proscenium. The ceiling can hang from the battens. The size of the shell can be varied by adding or subtracting flats and adding or subtracting ceiling sections.

VENTILATION

The major problem in ventilating an auditorium is to move sufficient air and yet not create drafts or disturbing noise. Since windows are not desirable in an auditorium, all ventilating will have to be mechanical. Most ventilating and air conditioning equipment is noisy, and many auditoriums suffer from a high ambient noise level. Air conditioning equipment, cooling machinery, ventilating fans should not be in close proximity to the auditorium. Ducts should contain acoustical lining as well as baffles to prevent the transmission of these machinery noises.

Backstage ventilation is a serious problem that is often overlooked. In hot weather stages become unbearably hot, especially when a number of high wattage lamps are used. Slow moving, belt-driven exhaust fans are suggested because they create the least amount of noise. This hot air should be exhausted from the upper part of the stage fly or grid. All the air must be moved that can be moved without causing the curtains to sway. Some stages use forced air for heat; again, care should be taken to keep this air from being driven against the stage curtains or scenery. Since the supply and exhaust of air must be directed away from the scenery, it is better to use some other means of heating.

The amount of air supplied backstage should not cause the front curtain to billow. There must be a balance of the air between the stage supply and the auditorium supply, and between the stage exhaust and the auditorium exhaust. Drafts in an auditorium or on a stage or in an orchestra pit are serious. They can affect stage scenery; they can affect the pitch of instruments performing on the stage or in the pit; they can cause untold discomfort to the audience.

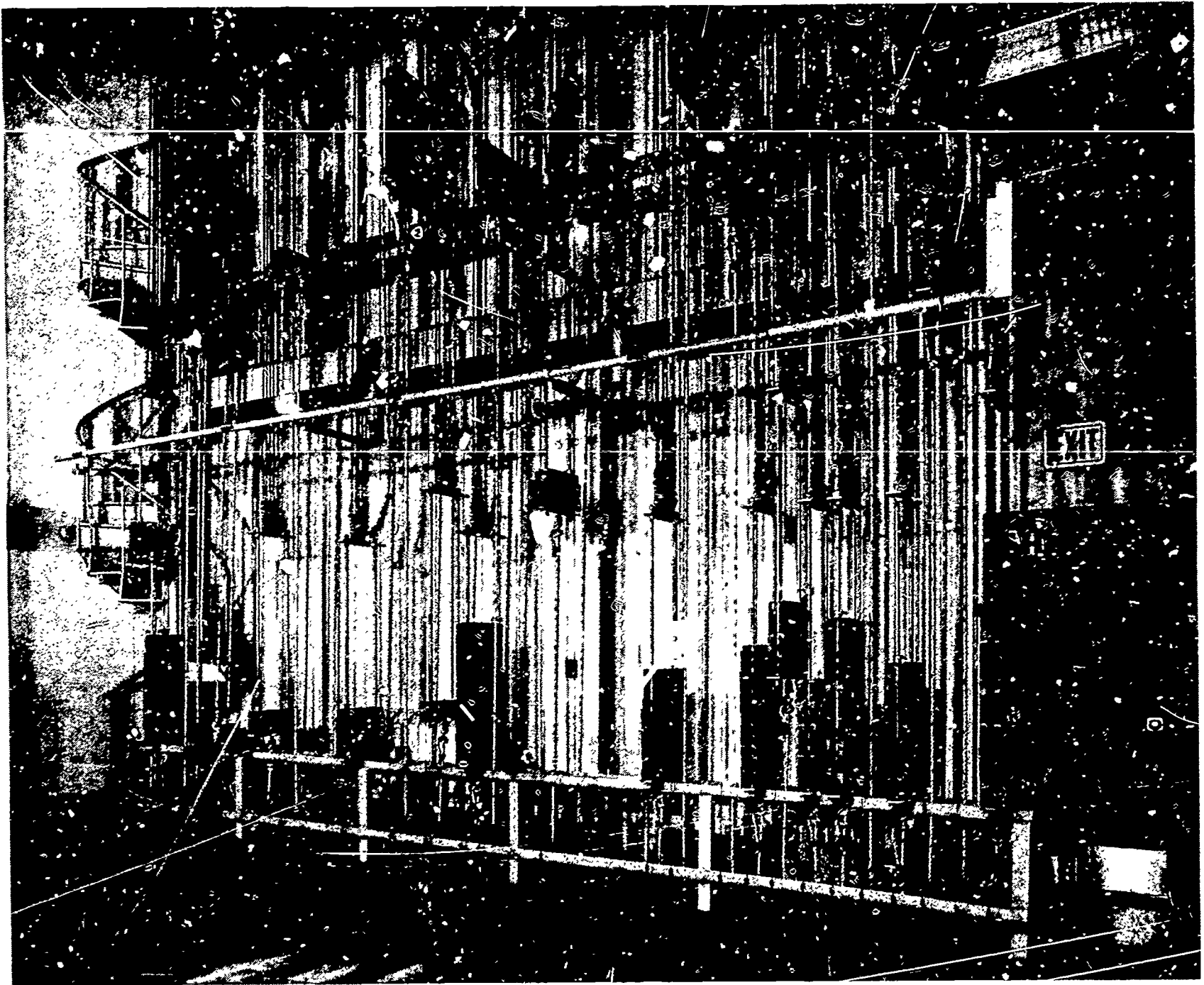

Figure 4.

DOORS

All doors entering on a stage must be of sufficient height and width to provide ready access to the stage. This is especially true of the scenery doors. They must be high enough to accommodate wide stage wagons, large instruments, and permit (if necessary) entrance of motor vehicles. The door for scenery should be at least 8 ft. wide and 14 ft. tall, and all other doors leading to and from the stage should be unusually wide double doors. Doors leading into the auditorium should be solid with no windows in order to avoid light leaks. All doors should operate silently. Panic bars on exit doors are generally required by law, but are sometimes rendered useless by padlocks and chains, an extremely dangerous practice.

SAFETY

There are many safety items to be considered on a stage. There must be adequate safety lights; that is, there must be lights that make the entire stage visible for night watchmen and others using this area after hours. The proper counterweights (Figure 4 and Figure 5) for handling pipe battens and scenery must be installed. Motor driven equipment must have recognized features and controls. Any one of the major scenery producers or manufacturers can give advice concerning this equipment. Many states require a fire wall between the stage and the auditorium. The switchboard should be properly grounded, all light battens should be properly grounded so that in case the lights do short out the operators will not be seriously injured. Stage properties

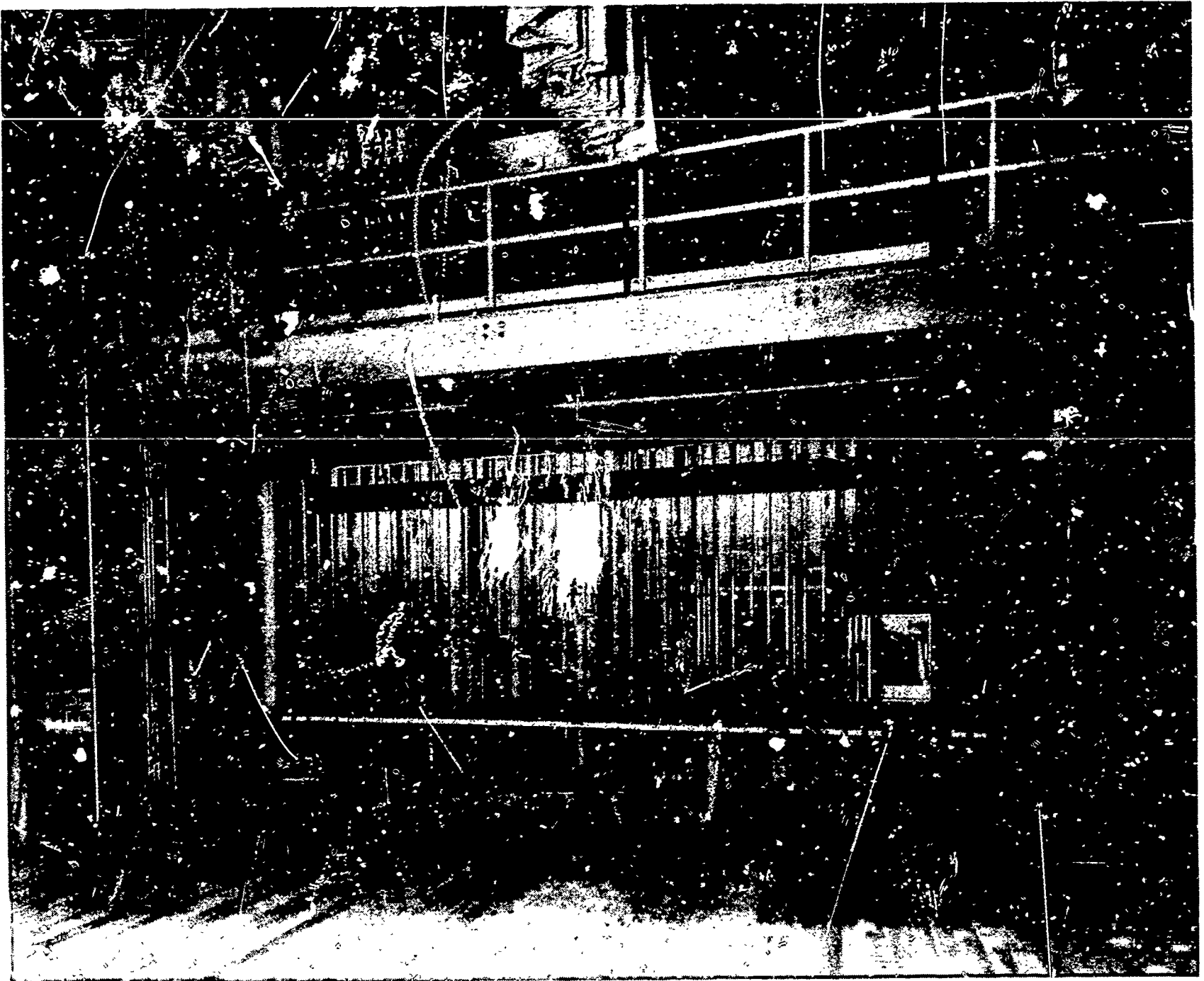

Figure 5.

can be handled safely only when there is adequate and proper stage equipment.

It is well to remember to use the best grade of white pine for making all scenery. This is a safety precaution and good economy. This grade of material may be salvaged and re-used several times in making some of the scenery, whereas the cheaper grades will splinter and break and frequently cannot be salvaged.

COMMUNICATION

Every auditorium should be equipped with the proper communication equipment. Intercoms or telephone lines should service the backstage area and provide contact with the front of the auditorium, manager's office, and ticket window. The auditorium communication system

can be planned to function with the central school system as well as serve the various activities within the auditorium. Sometimes outlets in the center of the auditorium are helpful for directors to communicate with the switchboard and other operating areas.

LIGHTS

There are many new concepts in stage lighting whether the facility to be lighted is the proscenium theatre, the open stage, or the modified proscenium stage. The border and footlight installations once popular in school auditoriums are no longer considered adequate. In addition to sufficient downlights for concerts and other non-theatrical presentations, school auditoriums need stage lighting for a number of specific dramatic

Control of stage lighting may be from a booth at the rear of the auditorium, front lighting and scene projection from ceiling slots.
 Findlay (Ohio) High School
 Perkins and Will, Architects

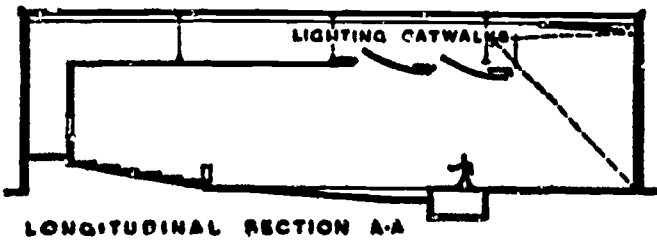
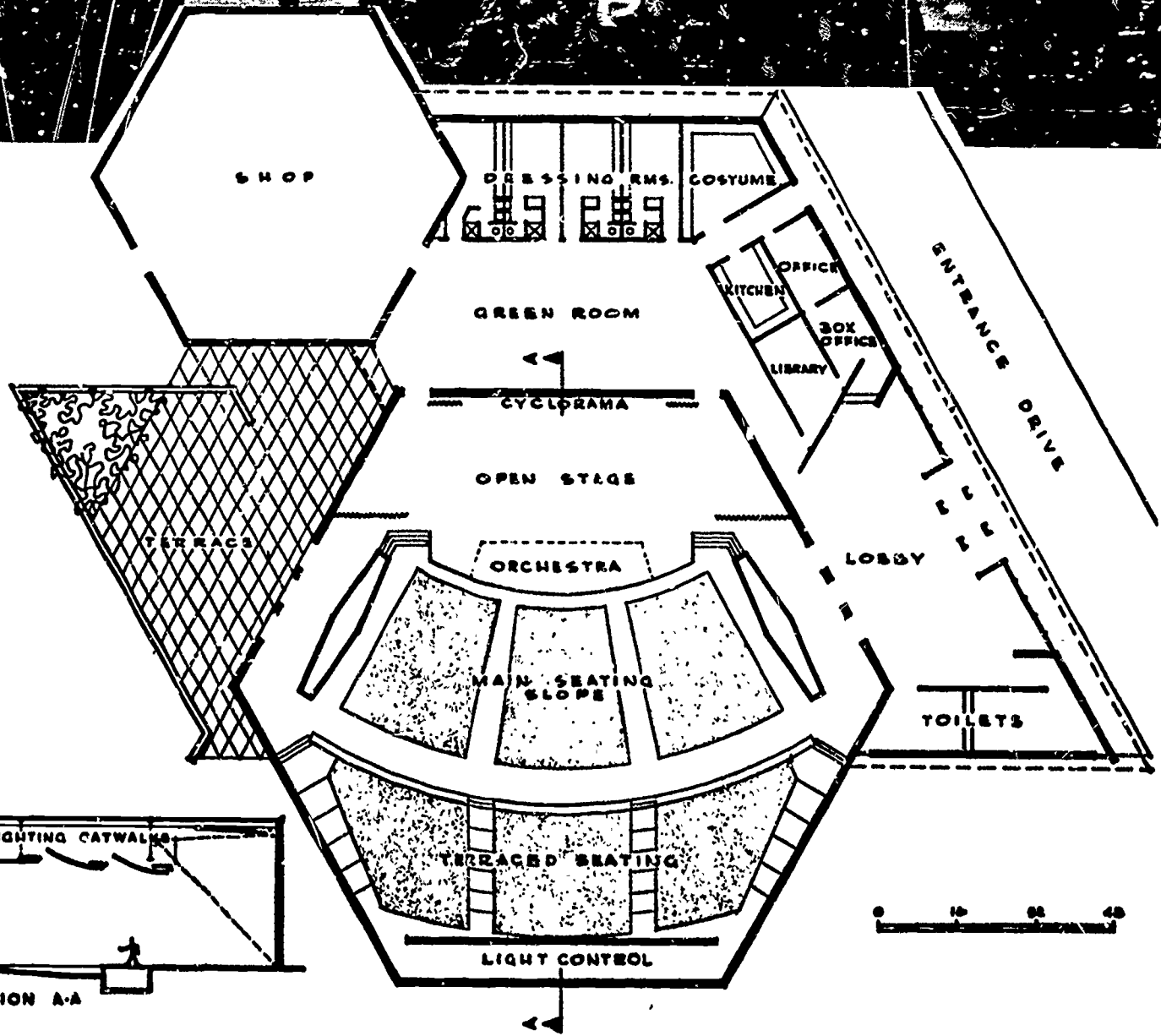
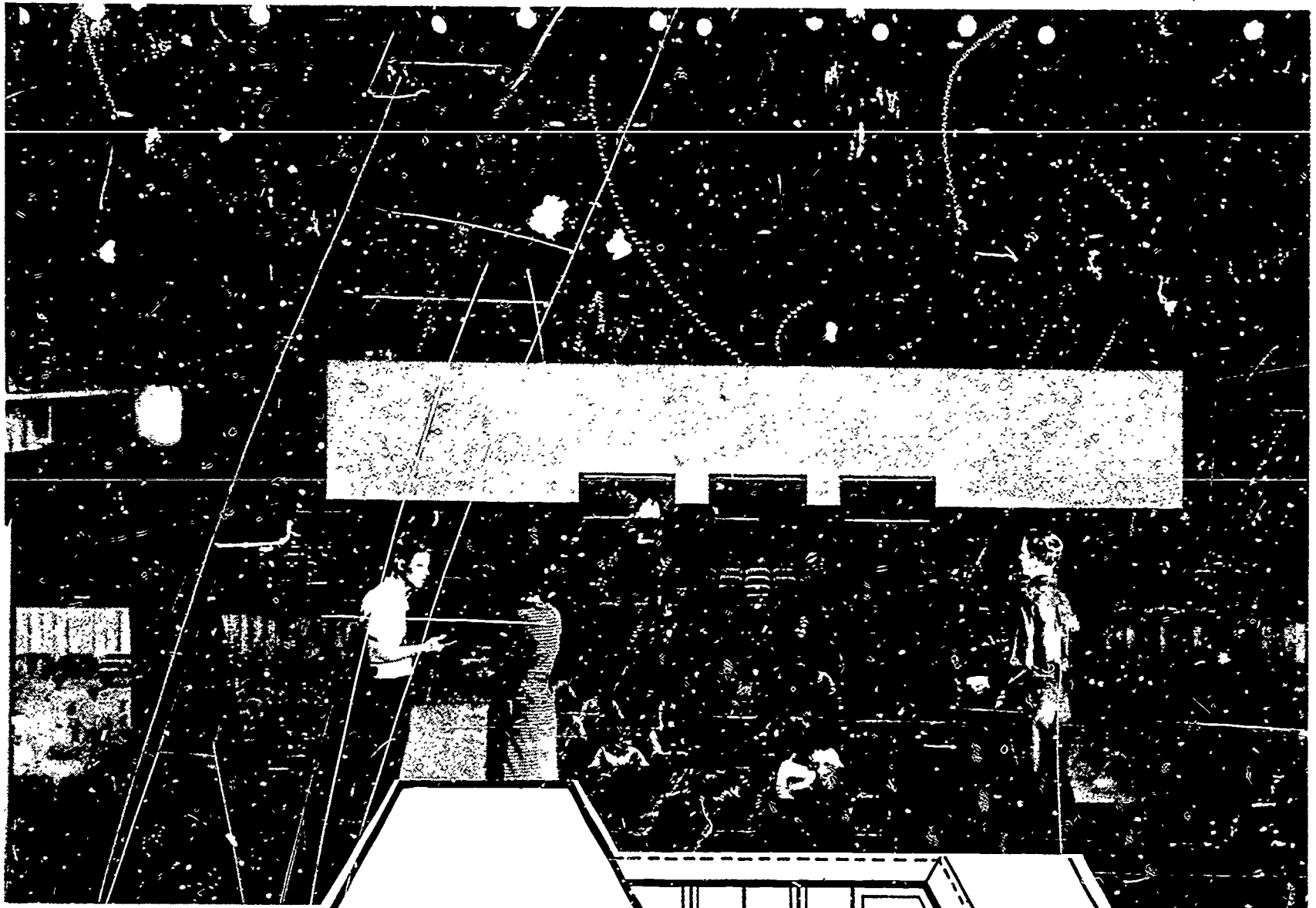

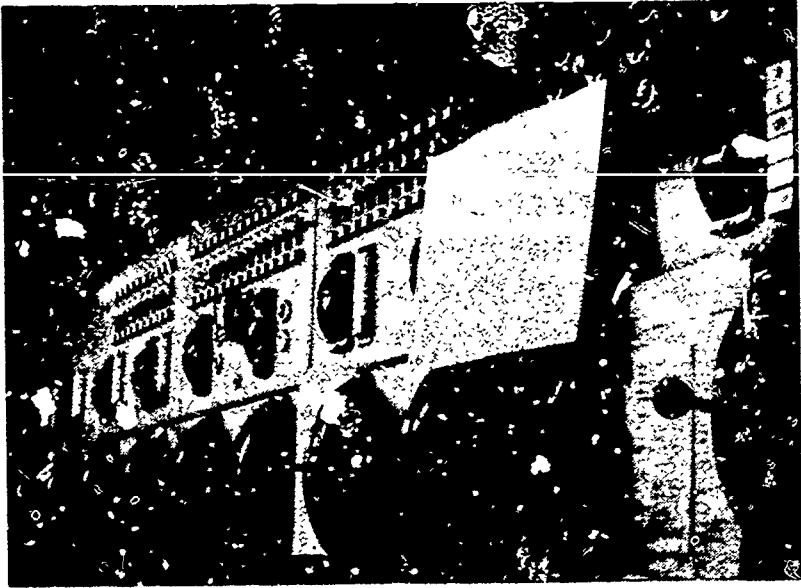

Figure 6.

purposes. The amount of lighting and the types required will of course depend on the design of the auditorium and the nature of the productions which are projected for it.

Front lighting from slots in the auditorium ceiling serviced by catwalks is highly desirable. Ellipsoidal spotlights are used to light the acting area. Additional spots may be desired in wall slots and a follow spot operated from a booth in the rear of the auditorium is common. Spotlights (generally softer Fresnel types) are needed on battens or on stands or tormentor pipes to provide further illumination of the acting area. Borderlights and sometimes footlights are employed for toning and blending. Beamlights are used for backlighting. Floodlights are used for background effects and special footlights are needed for a cyclorama. Sidelighting is sometimes provided by spotlights from a mobile tower in the wings. An elaborate college or community theatre installation may wish to provide a light bridge.

Open stages and modified proscenium stages frequently provide for projected backgrounds (See Figure 7). The lamp house for scenic projection may be located above the stage area or in a ceiling slot above the front curtain.

The stage switchboard may be located at the rear of the auditorium in a lighting booth; it may be located off stage on the stage floor, but out of the way of other operating equipment; or it may be located in an elevated position off the stage floor. Figures 5 and 6 show some switchboard facilities. They should be able to take care of an adequate number of floor pockets, three or four locations on both sides of the stage. These will vary in accordance with the size of the auditorium, stage, and its lighting equipment. A dimmer system (Figure 8) should be part of most school lighting installations.

There can never be too many outlets. It is better to have more adequate outlets than to chance overloading a few. Normally, there should be three or four locations for floor pockets across the right side of the stage, across the back of the stage, and each side of the proscenium arch, and along the stage left. Each of these pockets should be capable of handling from three to six 3000-watt circuits. In reviewing the preceding lighting layout, it should be remembered that all of the wiring for stage lights must be kept off the floor, out of the way of the scenery and the action. This is accomplished sometimes by using overhead flexible drops to service the ladders or towers. The tormentor lights would be serviced from the proscenium pockets. The auditorium and proscenium slots, of course, will be serviced from standard stage pockets located within the slots.

Sufficient provision should be made for adequate outlets for microphones and television cameras. Outlets are needed backstage, on the stage floor, over the stage area, on and over the apron, in the pit and over the pit. Outlets should also be provided in the auditorium seating area, and especially television camera outlets should be in the back of the hall and in the balcony.



Figure 7.

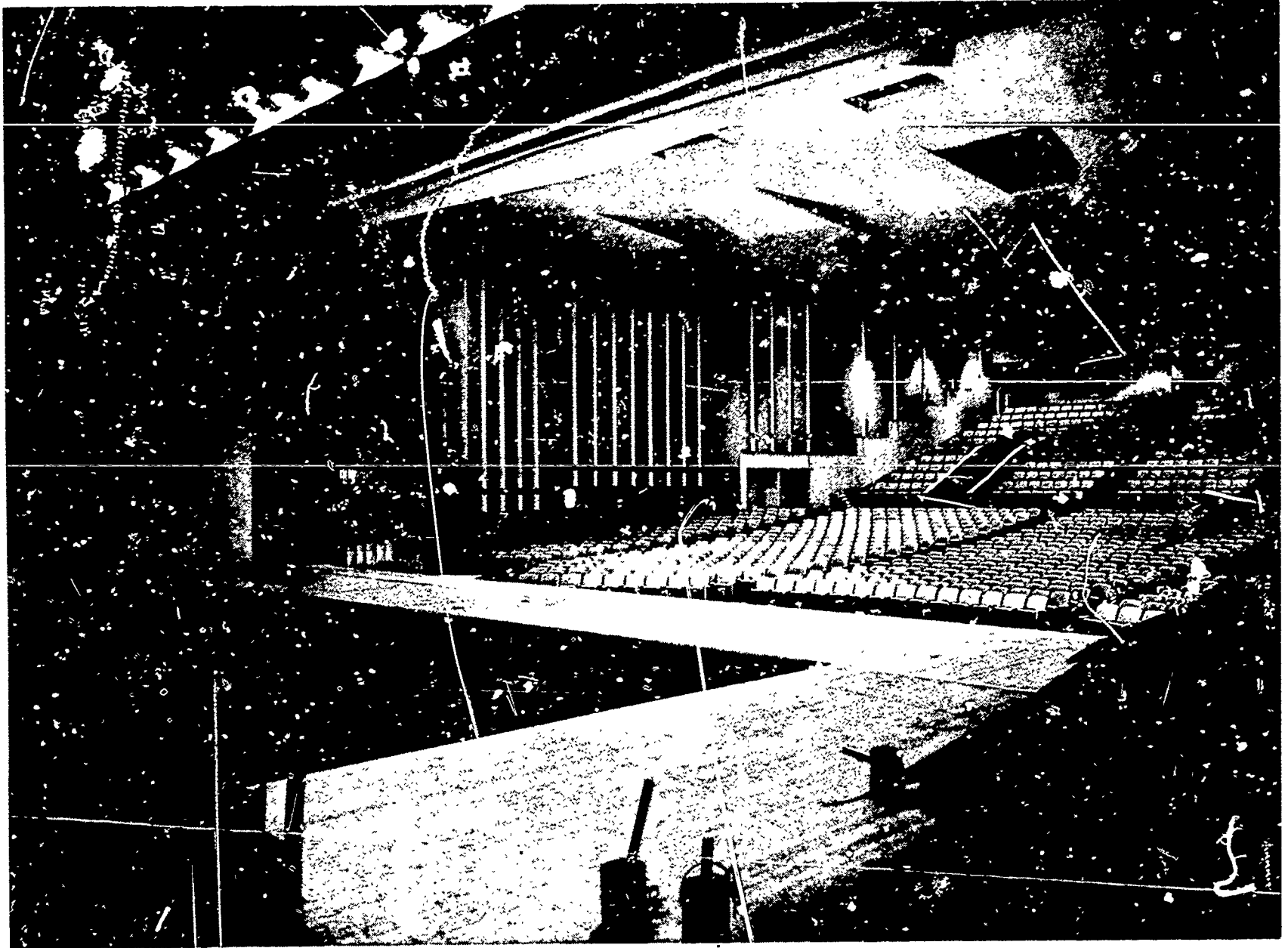

Ceiling and wall slots provide desirable front lighting. Note the two movable platforms which make possible a forestage.
 Evanston Township (Illinois) High School
 Perkins and Will, Architects

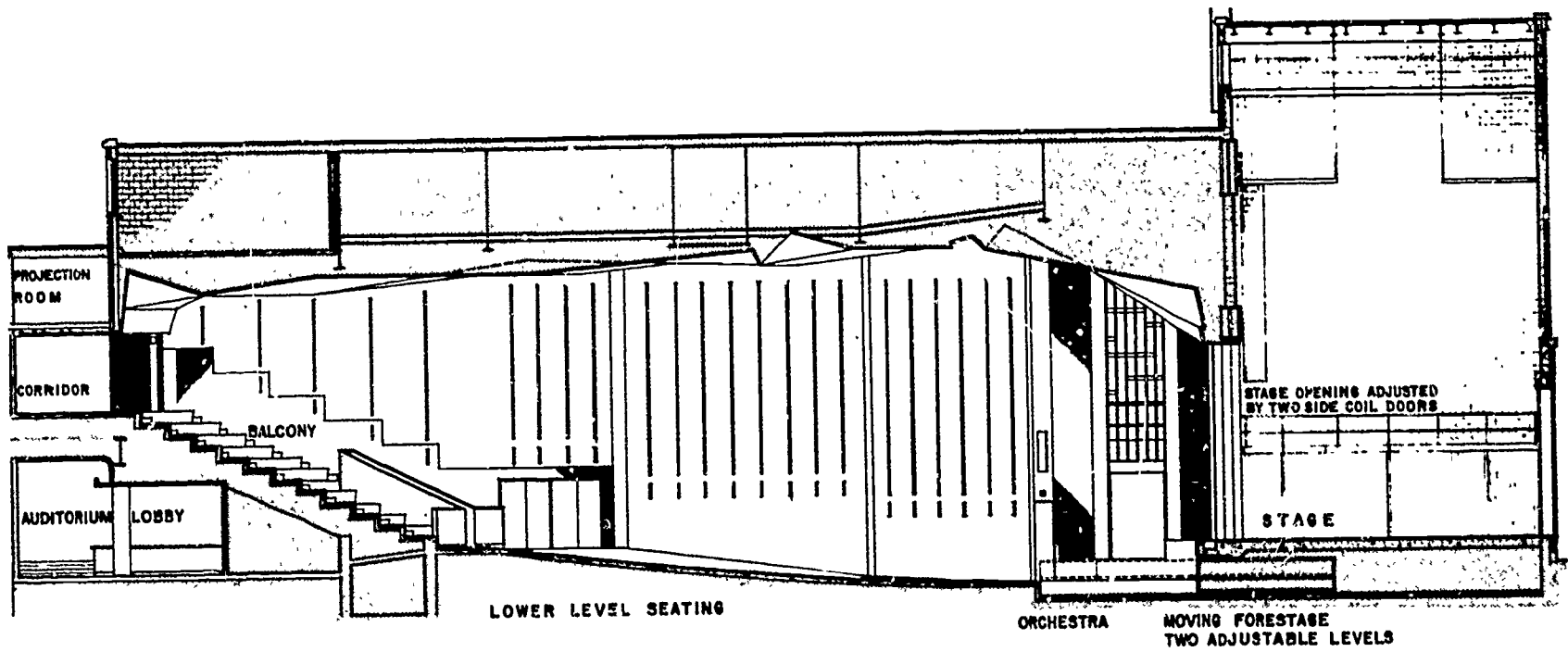

AUDITORIUM

LONGITUDINAL SECTION

SCALE





Figure 8.

RISERS

Portable risers should be provided as part of the regular stage equipment. These risers, if adjustable to suit choral groups, orchestra, or band (see pages 101-2), make it possible to stage all kinds of musical activities even if the instrumental groups alone prefer to perform on the flat. Dramatic productions require a different type of riser and in addition to the standard construction, occasionally adjustable hydraulically controlled risers are used. Storage space for risers should be planned.

ORCHESTRA PITTS

Most school auditoriums need an adequate orchestra pit. The pit should be in direct proportion to the size of the stage and the size of the auditorium and above all should be sufficient to house the potential orchestra of the school. That is, the potential school orchestra that would be required for performances of a musical play, operetta, or opera. The stage with a 45-ft. proscenium would probably have an orchestra pit of sufficient size to seat 60 players allowing 18 to 20 sq. ft. per player. Likewise a stage with a 60-ft. proscenium should have a pit large enough to accommodate a 100-piece orchestra. With a larger or small stage, the pit should be in direct proportion.

Playing an instrument in an orchestra pit sounds different to the performer than playing on a stage or in a recital hall. Figure 9 shows a rehearsal stage and rehearsal orchestra pit designed so that the orchestra

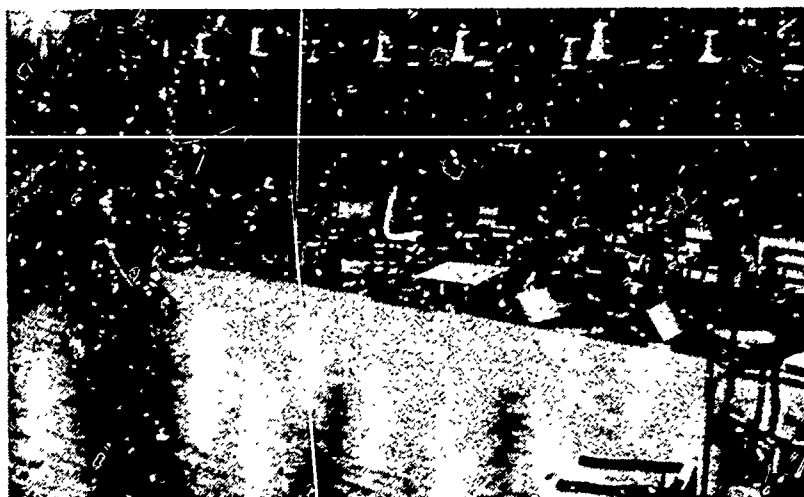

Figure 9.

does not take up time in the auditorium, but the dramatic performers and the orchestra can rehearse on this separate stage and simulate a performing area.

In order to give satisfactory performances to the audience, characteristics of the pit are bound to be different from those of the rehearsal room or stage. The orchestra pit should be treated acoustically so that the orchestra tone is subdued but not distorted. Echoes must be avoided. Singers must be heard over full orchestra. In dampening the orchestra tone, sufficient resonance must be maintained to keep a balance of tone and the proper quality of tone.

It is recommended that the type of acoustical block having holes or slots be placed along the entire width of the orchestra pit walls, front, side, and back. The ceiling of the apron over the orchestra pit could be treated; however, the amount of treatment is a matter for the acoustical engineer. It is recommended that a wood floor be used in the orchestra pit so that the proper resonance may be attained.

The pit area should be painted a flat black so that there is not a light reflection onto the stage interfering with the dramatic effects, although the area immediately back of the director is sometimes painted white so that the director will stand out to the players on the stage and to the orchestra. The pit should be deep enough so that the orchestra is completely out of sight of the audience. The director's podium should be high enough for him to be able to see the back area of the stage, yet remain in full view of the orchestra.

The railing around the entire orchestra pit must be high enough to hide the orchestra, yet low enough not to interfere with the sight lines of the audience. The head and the shoulders of the director may be visible over this orchestra pit railing. It is preferable, however, that the director be hidden from view of the audience so that there will be no distraction of any kind while the director is giving cues to the orchestra, cast, or per-

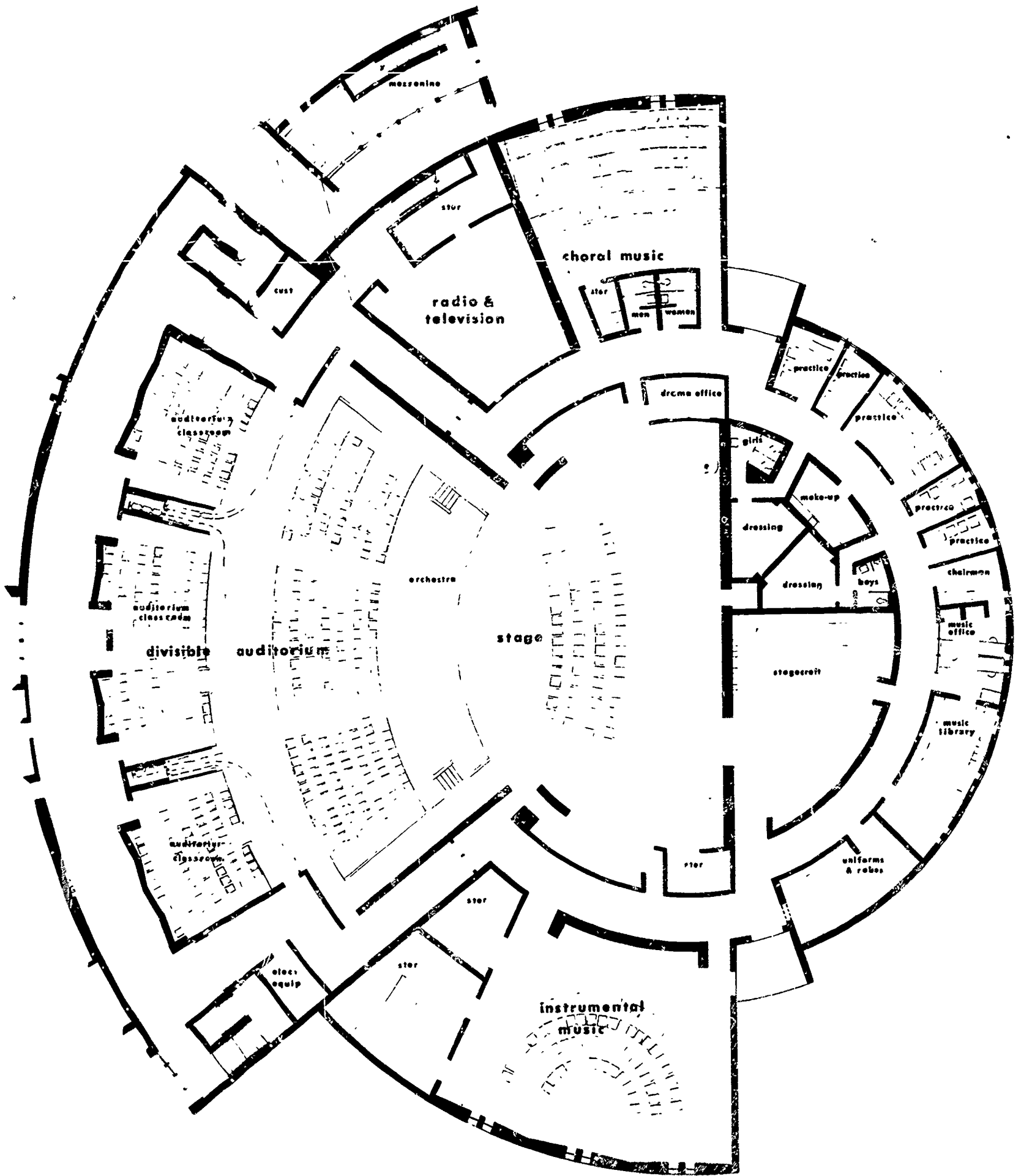

Divisible auditoriums provide a means of increasing the use of large areas.
Huron High School, Ann Arbor, Michigan
Lane, Riebe, Weiland, Architects

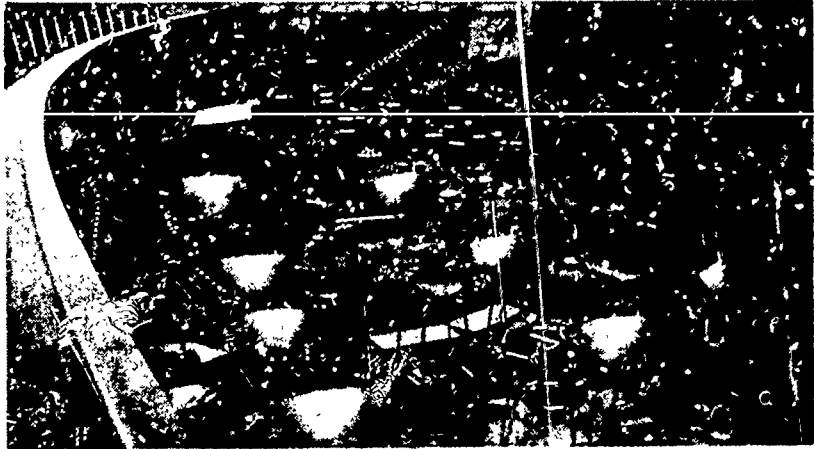

Figure 10.

formers. The pit shown in Figure 10 provides wide enough doors to accommodate the movement of instruments including a piano.

A moveable pit floor, usually known as a hydraulic pit, is a highly desirable though not inexpensive feature. The hydraulic pit floor should come up to stage level and then be lowered to the floor below. In this event the access will be a simple matter through double doors and the problem of determining adequate pit levels for performance is immediately solved. The hydraulic pit floor will act as a good sound reflector when not being used as an orchestra pit. At that time the pit will probably be located slightly below the stage level.

The orchestra pit, whether hydraulic or stationary, should be connected with an inner communicating system with stations backstage and to the front of the house with appropriate signal lights and/or signal buzzers.

Orchestra pit stands especially designed for theatrical purposes are available. They prevent light from spilling over and are large enough to hold the special and unusual sizes of manuscript paper. Each orchestra pit stand will have one or more built-in lights whose rays will strike the paper at a low angle, so that there will be a minimum of light. Light that spills off the stand is apt to interfere with various stage effects. The orchestra pit should have sufficient duplex outlets to take care of the music racks for the maximum size orchestra. These outlets should be installed in the floor and along the walls in order to eliminate the hazard of portable cables. The circuit will be controlled from the stage switchboard.

SEATING AREA

A factor that is often overlooked in the design of an auditorium is the seating capacity. In a commercial theatre and in certain other specific situations a hall is designed with the idea that it is necessary to have the entire potential attendance at one performance. The

larger the attendance, the less expense involved, the more money made.

In an educational situation, however, the auditorium or theatre is for an educational purpose, no matter at what level—elementary, secondary, or college—it is used. A fine program is prepared and, so far as the performance is concerned, there is value in having repeat performances. From this viewpoint it might be logical to reduce the seating capacity of the auditorium or theater and spend some of the limited funds in seeing that the auditorium has better equipment so that the performances can be presented adequately. This should be considered by school administrators and teachers when building the theatre or auditorium.

There are other reasons for considering smaller seating capacity. Although audiovisual aids can be presented to large mass groups, it is difficult to hold the personal student-to-teacher relationship that can be attained in smaller groups. In addition to a projection booth at the rear, consideration should be given to a projector platform closer to the stage for use with short range equipment. All booths and platforms should be located to clear the heads of people seated or standing.

The divisible auditorium is a concept finding increasing favor with those who need to justify the number of hours per day school facilities are used.¹ Such auditoriums are designed to be divided by sound retarding partitions into three or more areas for large-group instruction. Partitions may run from front to rear as well as across the auditorium (see Figure 11). Provision for projecting

¹ *Divisible Auditoriums*. New York: Educational Facilities Laboratories, 1966.

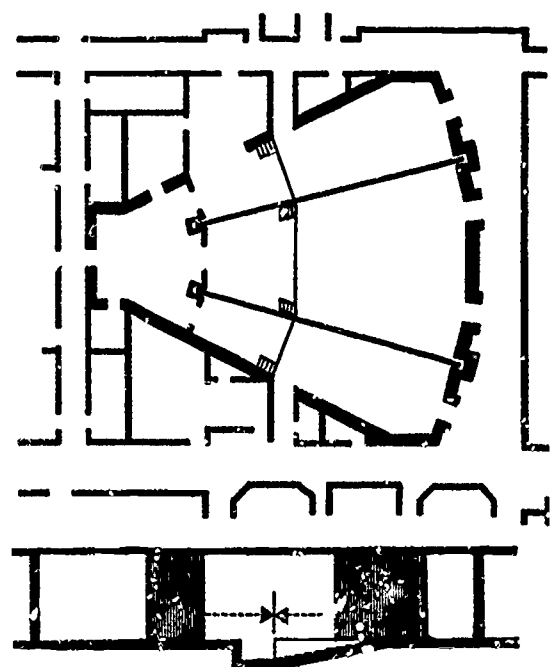

Figure 11. John F. Kennedy High School Plainview, Long Island, New York



The balcony areas of this divisible auditorium are provided with higher lighting and tablet-arm chairs at every other seat for study and testing purposes.
 Sycamore High School, Cincinnati, Ohio
 Thomas J. McClorey & Associates, Architects

films and other audio-visual materials should be planned for all areas.

PUBLIC FACILITIES

A common fault of school auditoriums is that the lavatories and public rooms are often quite a distance from the auditorium. In some instances they can even be in other parts of the building which are locked, so that there is no access to them during theatre performances. The lounge facilities to take care of the public between acts or during intermission should be large enough to be comfortable. These lounges and lobbies may be as luxurious as finances permit. The ventilating system should be separated from that of the theatre proper.

Auditoriums must be planned with adequate exits from the auditorium to the outside areas. The flow of pedestrian traffic to the ticket office, and into the audi-

torium and to and from parking facilities must also be considered.

The lighting in an auditorium does not need to be bright; but it should be placed on dimmers so that the quantity of light can be controlled for different situations. It is necessary to control these lights gradually to indicate intermissions and to bring the lights on gradually or take them off gradually for better audience comfort. Lighting should be of the type that can be increased or decreased from the stage switchboard or from the back of the house to avoid sudden shock following a dark house. Aisle lights and exit lights should be constructed so that they will not interfere with the stage effects. Exit lights should be placed in such a manner that they will not interfere with the dramatic lighting of the stage performance. These lights should not interfere with the audience view of the stage.

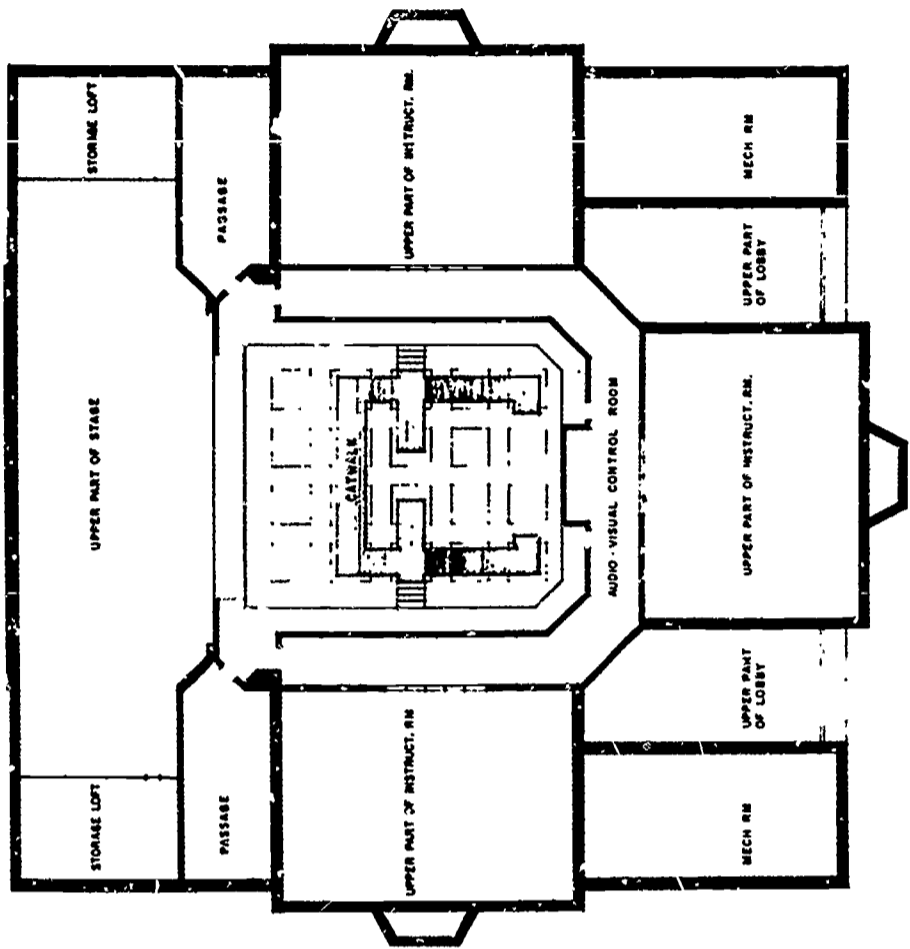

PLAN OF UPPER LEVEL

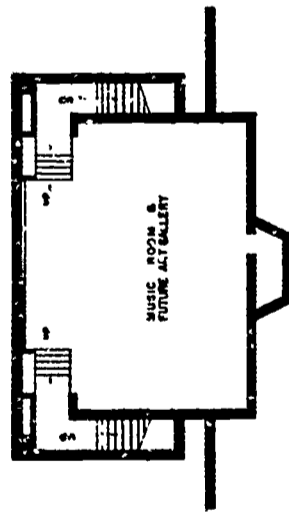

PLAN OF LOWER LEVEL MUSIC ROOM

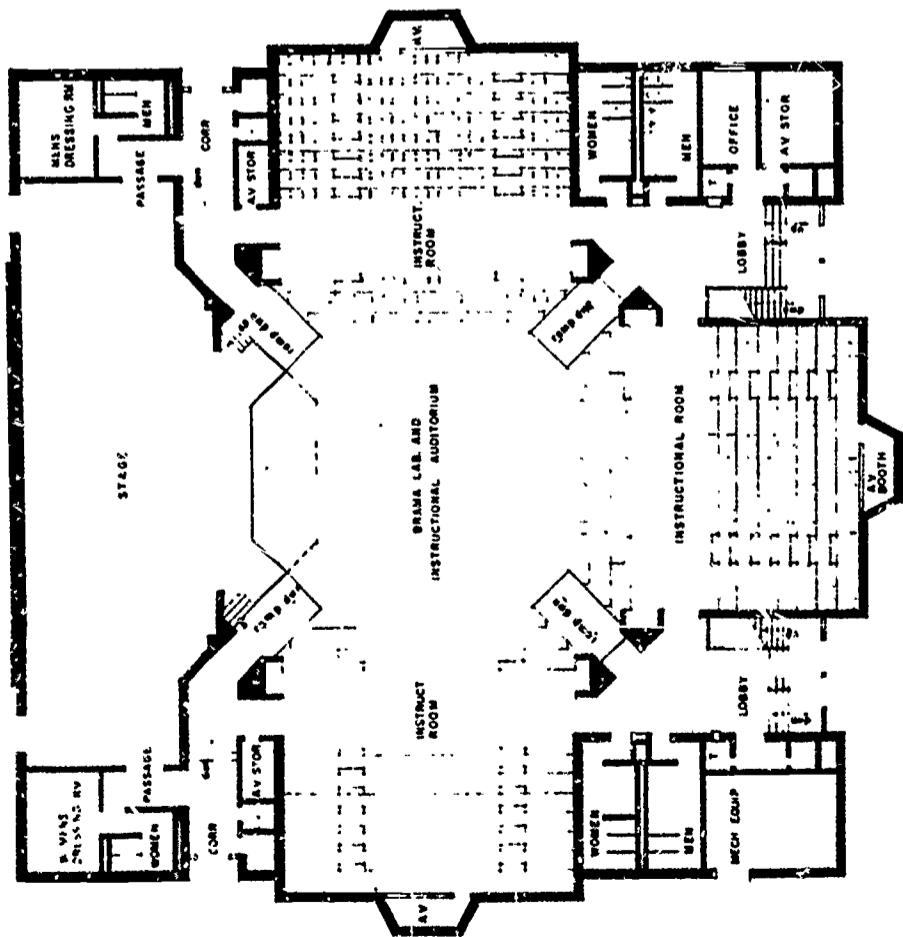

PLAN OF MAIN FLOOR LEVEL

A flexible facility can serve a variety of instructional and entertainment purposes.
 Montgomery Junior College Fine Arts Center
 Rockville, Maryland
 McLeod, Ferrara and Ensing, Architects

FLEXIBILITY OF THEATER STAGING

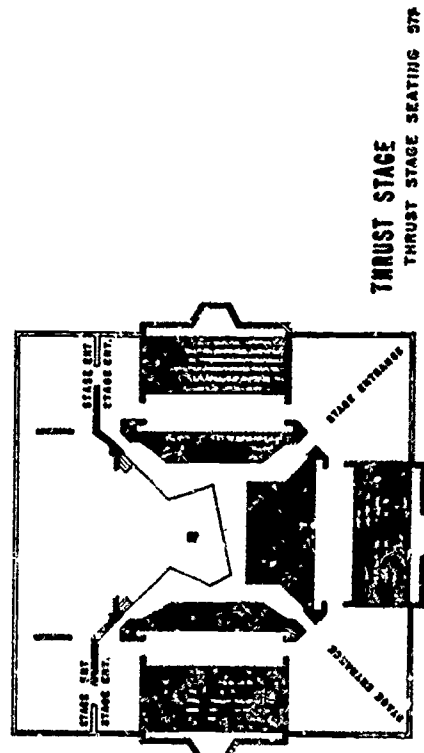
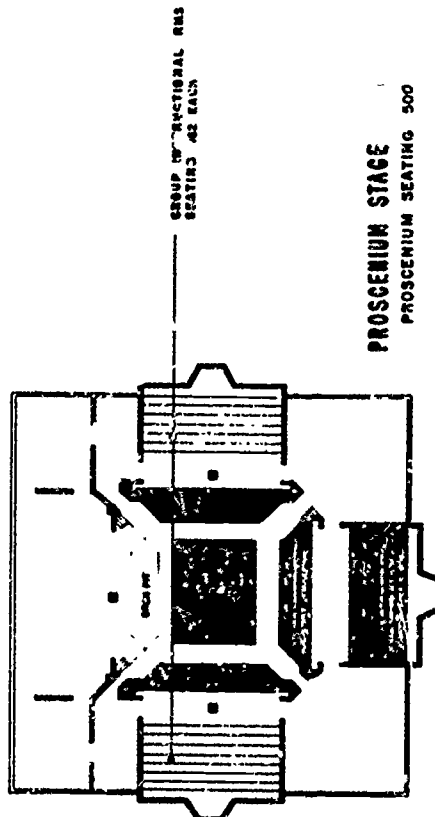
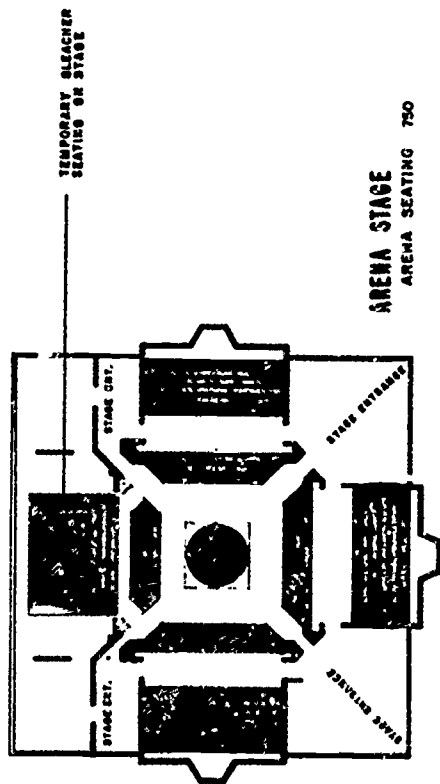

Montgomery Junior College Fine Arts Center Rockville, Maryland
McLeod, Ferrara and Ensign, Architects

DESIGN CONSIDERATIONS

THE ARCHITECTS' EARLY DESIGN STUDIES INDICATED THAT ANY ARCHITECTURAL SOLUTION WHICH WOULD SERVE THE MULTIPLICITY OF USES SET FORTH IN THE EDUCATIONAL PROGRAM COULD NOT BE DESIGNED IN TERMS OF A CONVENTIONAL SPECTATOR TYPE AUDITORIUM. THE CRUCIAL FORM SHAPE AS FINALLY DEVELOPED MET AND EVEN EXCEEDED THE CRITERIA REQUIREMENTS IN THE FOLLOWING RESPECTS:

1. THREE (3) LARGE GROUP LECTURE ROOMS WITH STEPPED SEATING FOR 162 PERSONS. EACH ROOM CAN BE CLOSED OFF BY FOLDING DOORS AND WILL HAVE PROVISIONS FOR FRONT AND REAR SCREEN PROJECTION.
2. THE LARGE FLAT CENTRAL AREA CAN BE USED FOR ASSEMBLY PURPOSES BY THE USE OF FOLDING CHAIRS. WILL PROVIDE 292 ADDITIONAL SEATS. THIS AREA WILL ALSO SERVE AS A DRAMA LABORATORY AND FOR DANCE REHEARSALS AND REHEARSALS. WHEN THE FOLDING DOORS TO THE LECTURE ROOMS ARE CLOSED SOME 250 STEPPED, FIXED SEATS ARE AVAILABLE FOR DRAMA AND DANCE CLASS SEATING AND DEMONSTRATION LESSONS.
3. THE THREE MOST COMMONLY USED TYPES OF DRAMA STAGING, PROSCENIUM, THRUST AND ARENA, CAN BE PROVIDED AT ANY TIME BOTH FOR CLASS PURPOSES AND PUBLIC AUDIENCE PRESENTATIONS. A RAISED CATWALK ABOVE AND AROUND THE CENTRAL AREA WILL PROVIDE FOR ALMOST ANY REQUIRED STAGE LIGHTING SITUATION.
4. MUSICAL EVENTS CAN BE PRESENTED EITHER ON THE PERMANENT PROSCENIUM STAGE OR IN THE CENTRAL AREA BY PLACING BAND RISERS AGAINST THE PROSCENIUM STAGE. MUSIC REHEARSALS WILL BE CONDUCTED TEMPORARILY IN A LOWER FLOOR ROOM WHICH WILL ULTIMATELY SERVE AS THE ART BALLERY OR GREEN ROOM FOR RECEPTIONS EXHIBITS, ETC.
5. THE MEZZANINE CATWALK ARRANGEMENT AROUND SIDES OF THE CENTRAL AREA WILL PROVIDE IN ADDITION TO A WORKING AREA FOR STAGE LIGHTING HOUSING FOR THE THREE AUDIOVISUAL CONTROL ROOMS. FOR OVERHEAD REAR PROJECTION INTO THE LECTURE SPACES THIS WILL MEAN THAT PROJECTION EQUIPMENT CAN BE SHIFTED IF NECESSARY. FROM PROJECTION ROOM TO PROJECTION ROOM IF THE COST OF PROJECTION EQUIPMENT MAKES IT IMPOSSIBLE IN THE INITIAL STAGES TO EQUIP ALL THREE ROOMS.

DETAILS OF FINE ARTS CENTER

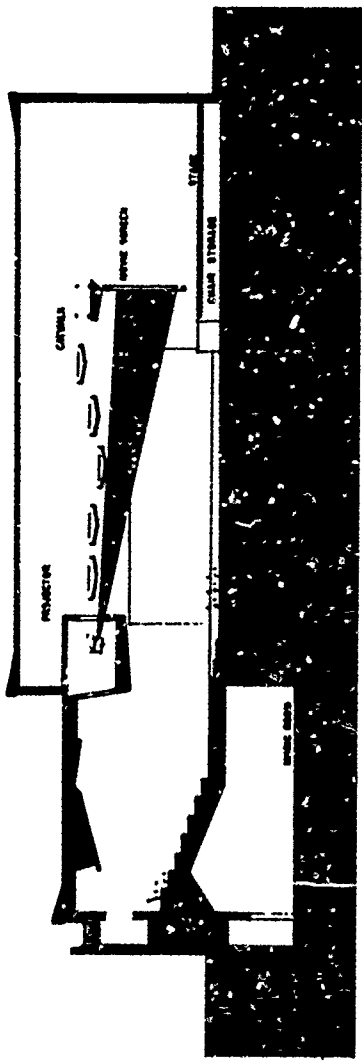

LONGITUDINAL SECTION

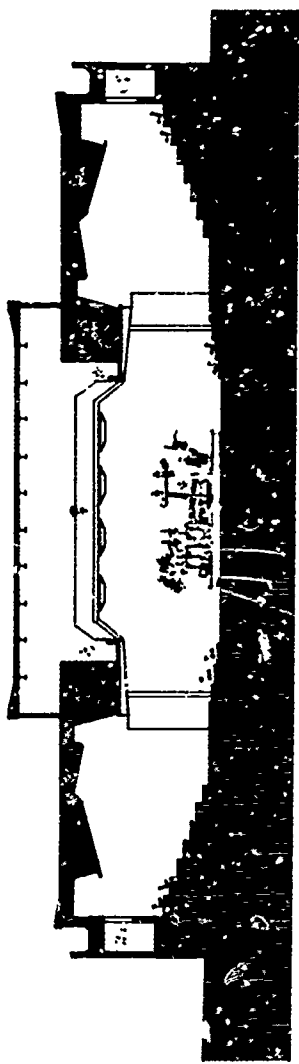

TRANSVERSE SECTION WITH FOLDING DOORS OPEN

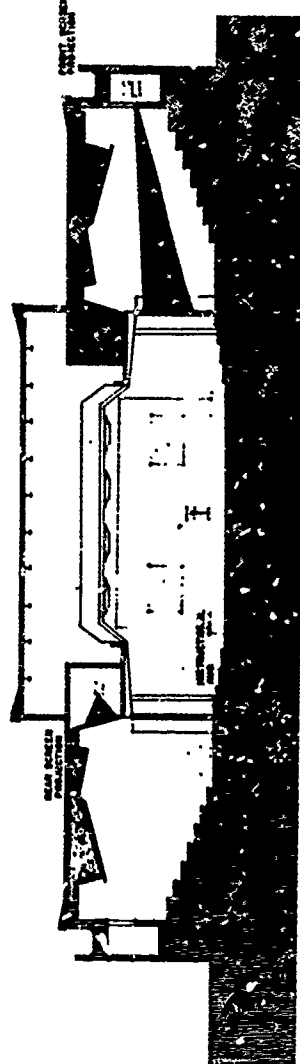

TRANSVERSE SECTION WITH FOLDING DOORS CLOSED

EDUCATIONAL PROGRAM

THE EDUCATIONAL PROGRAM FOR THE COLLEGE, AS PREPARED BY ODELL MAC CONNELL ASSOCIATES SETS FORTH THE REQUIREMENTS FOR THE FINE ARTS CENTER AS FOLLOWS:

1. FIRST STAGE CONSTRUCTION

A MULTIPURPOSE INSTRUCTIONAL AUDITORIUM

- A SINGLE TEACHING STATION FOR APPROXIMATELY 500 STUDENTS

- AT LEAST THREE TEACHING STATIONS WHICH COULD MEET SIMULTANEOUSLY PERMITTING THE SCHEDULING OF LARGE GROUP INSTRUCTION FOR CAPACITIES OF 125 AND 150 STUDENTS.

- PROVIDE A NOMINAL FLAT FLOOR AREA BETWEEN THE STAGE AND FIXED SEATS FOR INFORMAL ACTIVITIES.

- PROVIDE BOTH A STAGE AND BACK STAGE AREA FOR STAGE CRAFT, DRAMATIC PRESENTATION AND INSTRUCTION IN THE DRAMA AND THEATRE ARTS

- PROVIDE, IF POSSIBLE, OFFICE AND WORK SPACE

- PROVIDE A CENTRAL AREA FOR AUDIOVISUAL, MECHANICAL, AND ELECTRONIC INSTRUCTIONAL AIDS AND STORAGE, REPAIR, MAINTENANCE AND CONTROL

- PROVIDE FOR SCHOOL ARTS AND CRAFTS EXHIBITS

ALSO ADDED TO FIRST STAGE

MUSIC PRACTICE AREA

FUTURE CONSTRUCTION

COMPLETE MUSIC FACILITIES

COMPLETE ARTS AND CRAFTS FACILITIES

PUBLIC GALLERIES AND EXHIBIT SPACES

AS A FOOTNOTE TO THE EDUCATIONAL PROGRAM FOR THIS FACILITY THE EDUCATIONAL CONSULTANTS EXPRESSED THE HOPE THAT THIS FACILITY WOULD ENCOURAGE GREATER UTILIZATION OF A TRADITIONALLY LITTLE USED SPACE

BECAUSE OF THE UNCONVENTIONAL PLAN ARRANGEMENT IT WAS FELT THAT EXPERT ADVICE WOULD BE NEEDED IN THE FIELDS OF THEATRE, ACOUSTICS, MUSIC, AND LIGHTING. A GRANT FOR THE PURPOSE OF RETAINING CONSULTANTS IN THESE FIELDS WAS GIVEN BY THE EDUCATIONAL FACILITIES LABORATORIES, INC.

Technical Considerations

ACOUSTICS

Acoustics is important in *every* building, but this aspect of the environment must be particularly well handled in a music building. Without good conditions for performance, rehearsal, teaching, composing, or reading, a music building simply cannot provide the environment for good teaching. While it is true that many people have studied music in poor buildings, it is also true that it is easier and certainly more pleasant to do so in a good building.

To be discussed here are some of the aspects of a building that make it "good" and the general approach to the achievement of these conditions in both new and old structures. Acoustics, like structure, air conditioning, and lighting, must be thought about from the very beginning of building planning. It simply cannot be pasted in later.

Although sensible planning and arrangement of spaces can sometimes obviate the need for expensive sound-isolating construction, a music building will always cost more than an ordinary classroom building, and unfortunately there are no shortcuts to the achievement of satisfactory conditions. It either is or it is *not* a good music facility. Satisfactory acoustics is more than providing a space free from obvious acoustic faults, and it is more than isolating sound from surrounding areas when sound is not wanted. The acoustic properties of a room can enhance the quality of music for the listener and can give the performer a sense of support which adds to the pleasure and quality of his performance.

In approaching the design of a music building, one must have clearly in mind the two basic problems that must be faced. First, we must provide adequate isolation between various spaces for their satisfactory simultaneous use. Second, we must provide satisfactory room acoustics for performers and listeners. These two objectives are achieved by *completely* different mechanisms. Isolation is given by the construction separating two spaces, while room acoustics is determined by the shape and surface finish materials of the interior. There is often a misconception, for example, that the addition of sound-absorbing curtains on a wall will improve the isolation of sound from an adjoining space. It will do nothing but deaden the room itself, and will have no effect whatever on the amount of sound coming through from the next room.

SOUND ISOLATION

The degree of sound isolation required for various spaces in a music building will vary with the type of use. Perhaps the most critical isolation problem is that for teaching studios and classrooms. Any audibility whatever of musical sound gives "music intelligibility" as contrasted with the transmission of a mumble of speech in an adjoining room which merely tells us that something is going on there. This is especially critical in classrooms used for music theory, where any audibility of musical sound from an adjoining room during music dictation is most disconcerting. Score reading and composition also require inaudibility of sounds from adjoining spaces. Practice rooms probably have the least critical sound-isolating requirements although, even here, they will not be considered really satisfactory unless some special pains are taken to provide more than the usual classroom separation.

Large rehearsal rooms and recital halls can often be placed in separate units and achieve the isolation they require almost automatically. While one could conceive of a music building in which the isolation for all spaces could be achieved by widely separating all the rooms on a single level, this is hardly practicable. Spaces should be conveniently related to each other and this means that ways must be found of providing the required isolation between closely adjoining rooms.

Effective sound isolation between rooms is given by heavy, airtight walls and floors—the heavier the better. There is a limit, however, to how much isolation can be achieved in a usual building. No matter how heavy a wall is made some sound will travel along through the floor and ceiling slabs to adjoining spaces on the same level. The isolation limit set by these "flanking" paths is too low for the critical spaces in a music building. Resort must be had to more complex constructions than those usually satisfactory in classroom buildings.

One can achieve *very* high values of sound isolation in a concrete building only by "floating" an inner skin for each of the spaces within the basic structure. The structure of the building must be protected from airborne and structure-borne sound waves by the addition of a resiliently separated layer of plaster or concrete. A discussion of this complex type of structure with an architect almost always elicits the question "Isn't there some simpler way

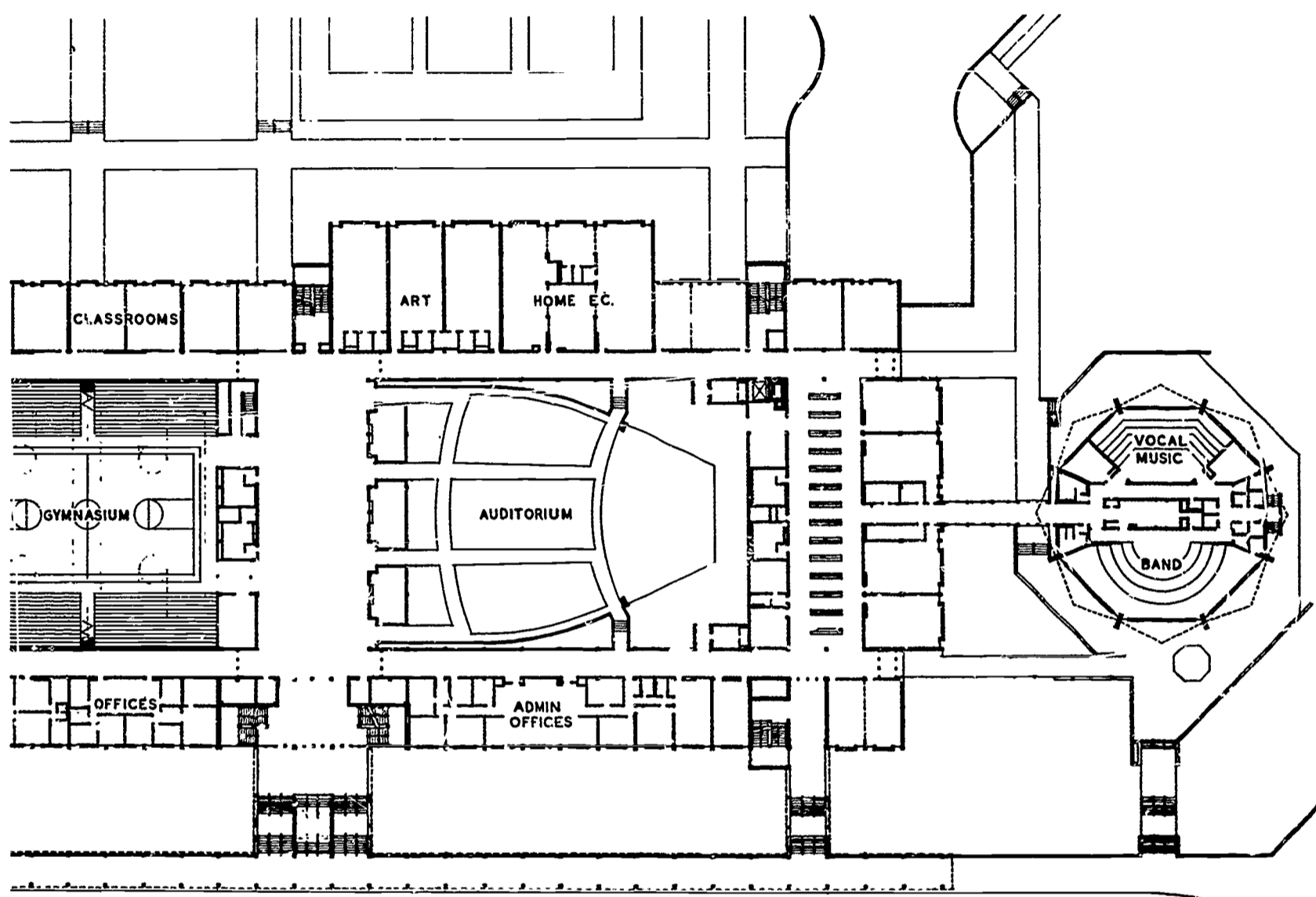

FIRST FLOOR PLAN

Large rehearsal halls can often be placed in separate units to achieve sound isolation.

T. C. Williams High School, Alexandria, Virginia

Saunders & Pearson, Architects

of doing it?" The answer is, "Unfortunately, no." This type of floated interior construction also gives isolation from structure-borne sound from pianos, cellos, and other instruments that drive the floor directly.

The needs for such high sound isolation preclude the possibility of using natural ventilation, even though one often hears the argument that singers need fresh air to perform properly. They can't have it unless the neighbors are prepared to hear the singing! A *music building must be air-conditioned throughout, and air must be supplied through sound-absorbent, lined ductwork and returned through lined ductwork.* Door louvers and other usual ventilating practices found acceptable in ordinary office or classroom buildings are out.

While the isolated interior skin of the room may be shaped to serve the purposes of good room acoustics, its basic property is that it must be heavy and continuous

and that it not be shortcircuited to the basic structure of the building by electrical conduit, ventilating ducts, or any other rigid path. The solution of the problems of detail at windows and doors is not easy and must be worked out in each case, but these problems can be solved if the designer is willing to take the trouble. The investment in added cost of construction will not be realized in adequate sound isolation, however, unless every single detail is solved in the design and is carefully seen through to completion. It has been found helpful to instruct the workmen in the reasoning behind the fussy construction system being used and the necessity for avoiding any accidental bridges between the floated interior and the basic structure of the building.

Doors to all such isolated rooms must be of special sound-isolating construction and they must be fully weatherstripped on all four edges. Any leaks or cracks,

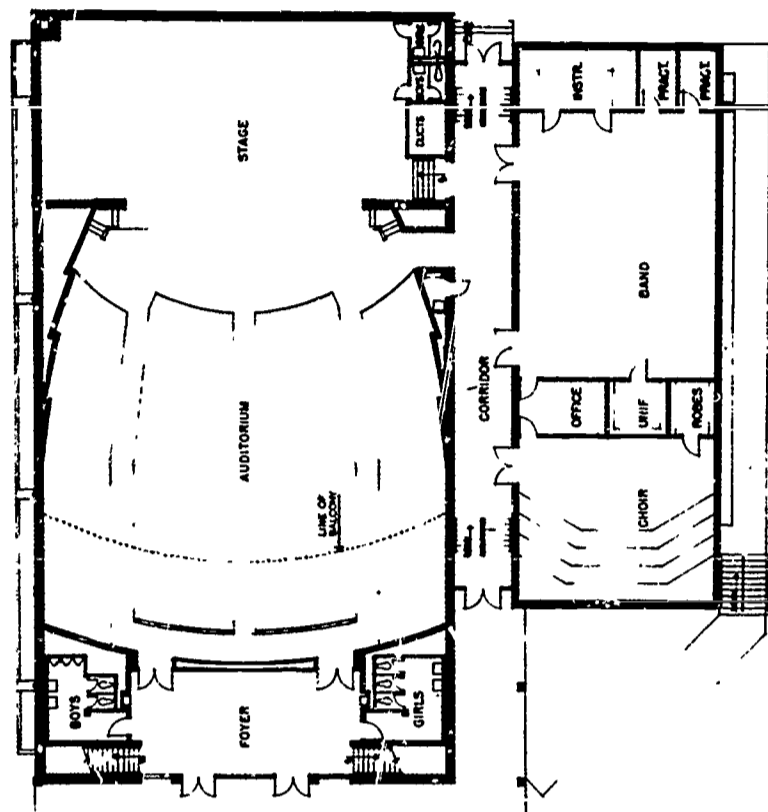

Effective sound isolation between rooms is given by heavy, airtight walls and floors or by corridors and storage areas.

Jacksboro (Texas) High School
Preston M. Geren, Architect

no matter how small, will nullify the effectiveness of these doors, and weatherstrips must be maintained and adjusted from time to time to keep them airtight.

Recently a music school provided such weatherstripping and the doors were equipped with automatic closers. It was a policy of the school that doors to all teaching studios and practice rooms should be kept locked when they were not in use, and in order to be sure that the doors were always closed and locked (because students never bother to close doors), automatic closers were installed. The problem was that the closers were not quite strong enough to provide positive locking of the door every time against the resistance of the weatherstrip that had been installed for sound isolation. This was solved by filing away the catch until the automatic closer *would* latch the door, and this meant that the weatherstrip didn't quite engage the door, and most of the value of its sound-isolation was lost. This may seem a small point, but it is necessary to be realistic about these things and realize that perhaps the automatic door closers that work for ordinary doors simply will not do the job in a music building. Glass vision panels in doors present no problem.

Even with well-sealed doors, there will be appreciable sound transmission to the corridors, but it is seldom considered worthwhile to install two doors with a sound

lock in between to solve the problem. From room to room there will always be two doors in the patch, and room to corridor isolation isn't terribly important—and besides, it makes it sound like a music school.

A music building incorporating this kind of construction will be much more expensive than a normal classroom building; in fact, it can be twice as expensive but, unless these precautions are observed and this type of construction incorporated, a musical "slum" will be the result.

Practice rooms can often be handled a little more simply in terms of isolation, but they, too, require supply and return of air through lined ductwork, and the use of weatherstripped doors—perhaps less expensive ones than those for teaching studios and classrooms. This assumes that there will be some audibility of sound from an adjoining room when no sound is being made in a given room, but that it won't be enough to disturb a person who is practicing an instrument.

Even when the complex type of construction just described is used, there still may be some audibility of musical sound from the next space if the background sound level is very low. Experience has proved that, along with the very best sound-isolating construction that can reasonably be done, there must also be a moder-

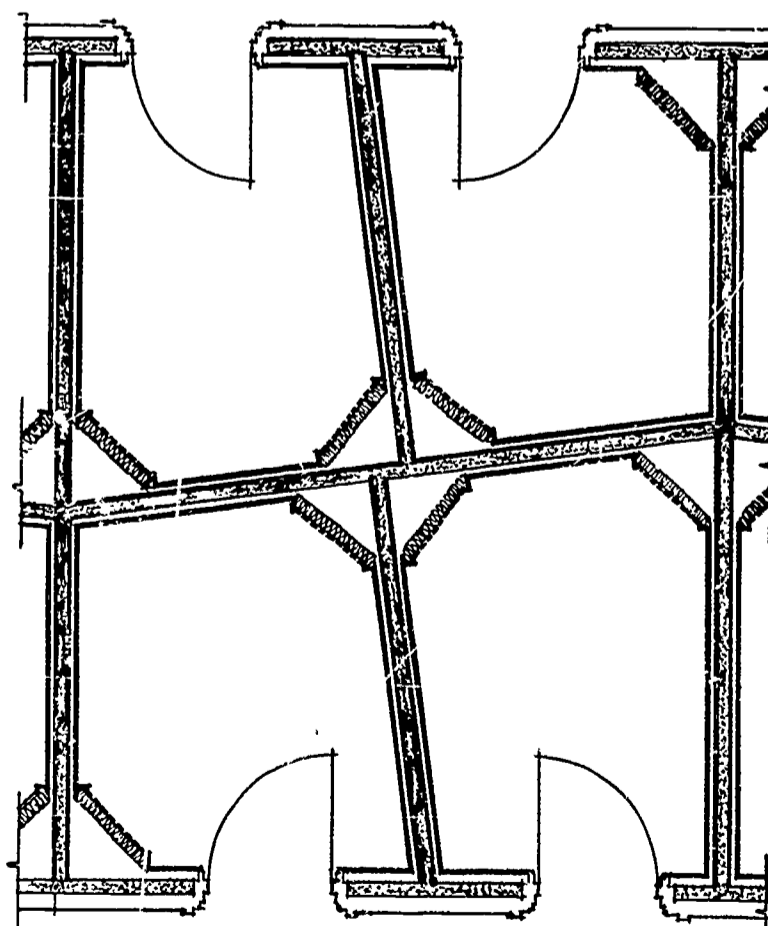

Non-parallel walls offer one means of avoiding flutter echo. Sound absorbing materials in two corners of small rooms will reduce low frequency resonances.

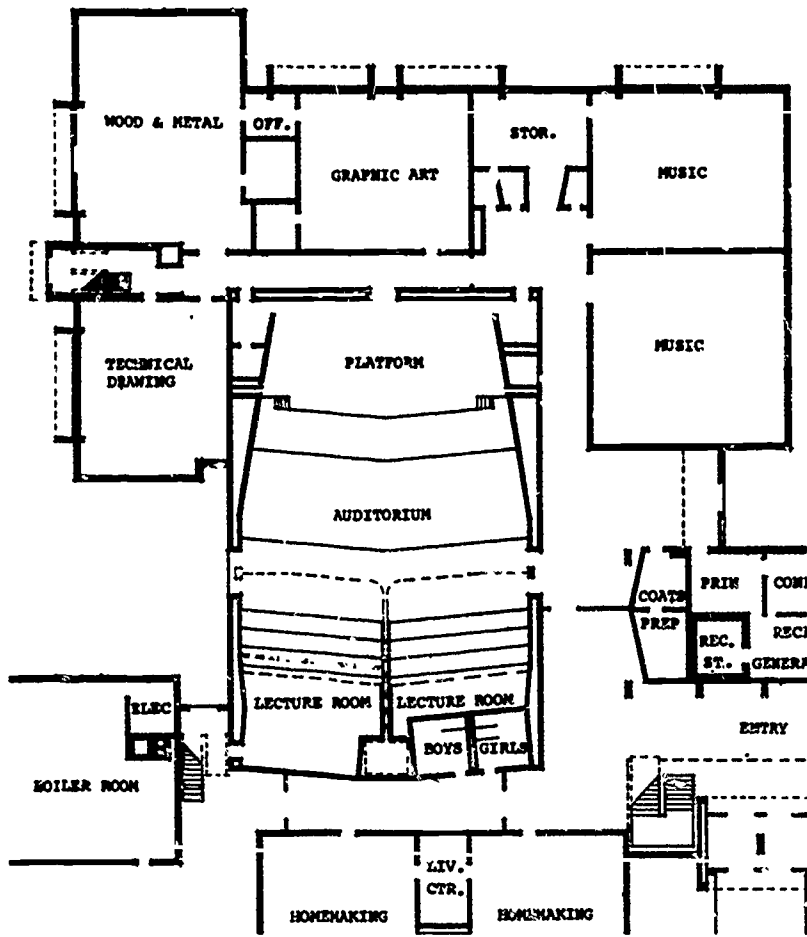

Instrumental rehearsal halls must have adequate ceiling height.

Kennedy Junior High School
Natick, Massachusetts

Davies & Wolf, Freeman & Flansburgh, Associated Architects

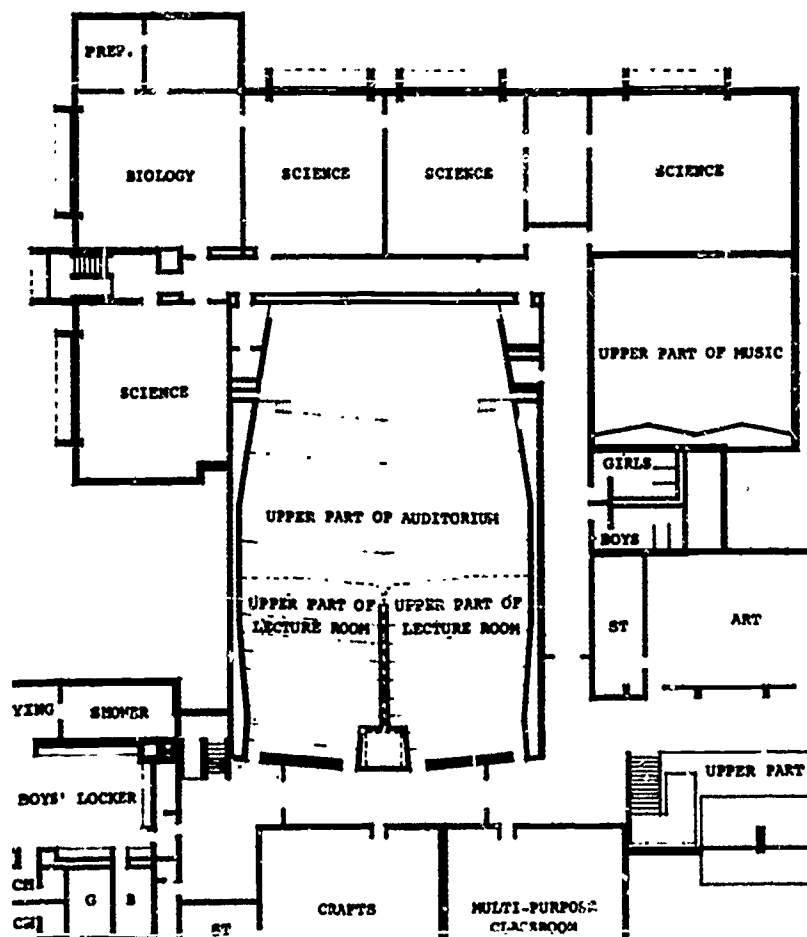

ate background noise level in teaching and practice spaces. This does not mean that we want a great roar of noise, but the air conditioning system can be counted on for slightly audible amounts of "air" noise. This can be described in air-conditioning terms as a background noise spectrum of NC 30-35. Such a background noise will in no way interfere with normal activities in teaching spaces and will very effectively mask or conceal the tiny amounts of sound energy that inevitably intrude with even the best construction. Only with a controlled background noise present can really "soundproof" conditions be obtained.

Such a masking background can also be very useful in the music library to hide both speech and musical intrusions from other activities there. Music listening rooms associated with the library need the same sort of construction as teaching studios, but even then they won't be "soundproof" without a moderate continuous background noise.

Recital halls and auditoriums, however, must be completely free of noise. No masking is wanted there.

No matter how effective the sound-isolating construction between spaces may be, the overall isolation achieved will always be better if there is no insistence on such difficult relationships as rehearsal rooms over recital halls or heavy mechanical equipment under the stage of the auditorium or, in fact, any very heavy noise-makers near areas that must be kept quiet. Isolation *can* be achieved in such situations, but it always costs more than when it is possible to separate these elements more widely in the building. Sound-absorbing treatments should be used in all corridors and lobbies to minimize the transmission of such sound as gets into these spaces, and as many doors as possible should be closed between rooms to be isolated from each other. No amount of treatment of corridors can be as effective as a closed door.

ROOM ACOUSTICS

When the required isolation has been provided, the concern must be with how these isolated spaces sound to their occupants. The room acoustics problems in small practice rooms are quite different from those in large recital halls and auditoriums, and it is impossible to make them "sound alike" as architects are often asked to do. The reverberation time in a small studio must be considerably lower than that considered ideal for a large rehearsal room or a recital hall if it is going to be a tolerable space. Because sound travels at the same speed in all spaces, the separation between successive reflections of sound becomes greater in larger rooms,

and satisfaction of the criteria for good hearing requires rather different approaches in handling the shape and finish materials.

Small Rooms.—In the small practice room or teaching studio, for example, there will be strong resonant frequencies in the audible range (the "bathroom tenor" effect) that must be suppressed. In some cases, the control of these resonances may require that the room have certain proportions of dimension. In the larger rooms where the predominant resonances are at sub-audible frequencies, proportions become less important than certain basic requirements for height and width based on sound distribution requirements. These physical requirements differ from one situation to the next, and it is difficult to generalize.

To control the low-frequency resonances of small rooms, special sound-absorbing treatments are used in perhaps two corners of the room. (The corners are the most effective place for adsorptive treatment to control these resonances.) In addition, for reverberation control either a sound-absorbing ceiling or perhaps a fully-carpeted floor would be incorporated to give a satisfactory condition. Sometimes a curtain track is provided along one wall so that a heavy drapery can either be extended across one wall or pushed back into the corner to vary the reverberant characteristics of the space. These are matters of individual taste and preference, and one cannot predict in advance just what the individual is most likely to prefer. A completely hard-finished small room will be liked by no one, and a room completely padded with sound-absorbing material is also unlikely to be appreciated. Somewhere in between these extremes is usually acceptable.

Some device must be found for making the walls of a studio non-parallel to avoid flutter echo or "ring," the reflection of sound back and forth between parallel surfaces. Such a flutter was described recently by a faculty member in a new school of music as a "death rattle." Parallelism can be avoided either by gross skew or tilt of the walls or by such added devices as tilted blackboards, bookcases filled with "junk"; modulation of the wall surfaces in and out with large-scale bumps and irregularities; in fact, almost any architectural device that destroys the smooth parallelism of two wall surfaces will handle the flutter problem.

The important thing, then, in the interior design of a small studio is that it be somewhat irregular to avoid smooth parallelism and that the reverberation time be controlled with added sound-absorbing treatment, some of it especially for the control of low frequency "boom" or resonance. Whether the room is finished in plaster

or wood is a matter of individual preference, and a wide variation of treatments can produce acceptable results.

Classrooms.—The larger classroom spaces do not have the problem of low-frequency resonance because the principal resonances will be below the audible range. It is important in the classroom to avoid flutter echoes, back and forth between parallel wall surfaces, and to control the reverberation time with adequate treatment on wall and ceiling surfaces. Here again, it is important to have some fairly deep treatments to be sure that the low-frequency reverberation is not too long, and yet there must be some life in the room to enhance the quality of musical sound. Such devices as tilted blackboards can solve some of the shaping problems.

Rehearsal Areas.—Large rehearsal rooms for instrumental groups and for choruses often suffer from inadequate volume. A large instrumental rehearsal room should have at least a two-story ceiling height for satisfactory conditions. Here, as in the teaching studios and classrooms, parallel hard wall surfaces should be avoided, and the sound-absorbing treatment needed for the control of reverberation can be incorporated in the wall areas to help achieve this breakup. The ceiling of such a room should have a mixture of sound-absorbing and sound-reflecting surfaces, to give a good amount of cross room reflection enabling the musicians to hear each other. Generally speaking, rehearsal rooms should not be too reverberant in order that the faulty performers can be readily identified and corrected.

As in teaching studios, large areas of heavy drapery are sometimes provided for extension across one or two walls to vary the characteristics of the room with size of group and preference of the musician in charge. If the design of such a rehearsal room depends upon the drapes for control of reverberation time, the installation of the curtain should not be left for later addition but ought to be part of the original building budget. There have been cases in which the curtain was left out originally and the rooms were unsatisfactory until the drapery installation had been completed. It is recommended that the room be finished for reasonably satisfactory rehearsal conditions without a drapery and that this be added only to bring the reverberation time down even further. Rugs can also be added on the floor if additional control is needed. The fixed sound-absorbing treatment should be fairly deep in order to give adequate low-frequency absorption, and, in a sophisticated design, special low-frequency absorbers might well be designed as part of the overall treatment. Here again, there is a wide variety of solutions available to the architect, and the exact treatment selected will depend on budget and

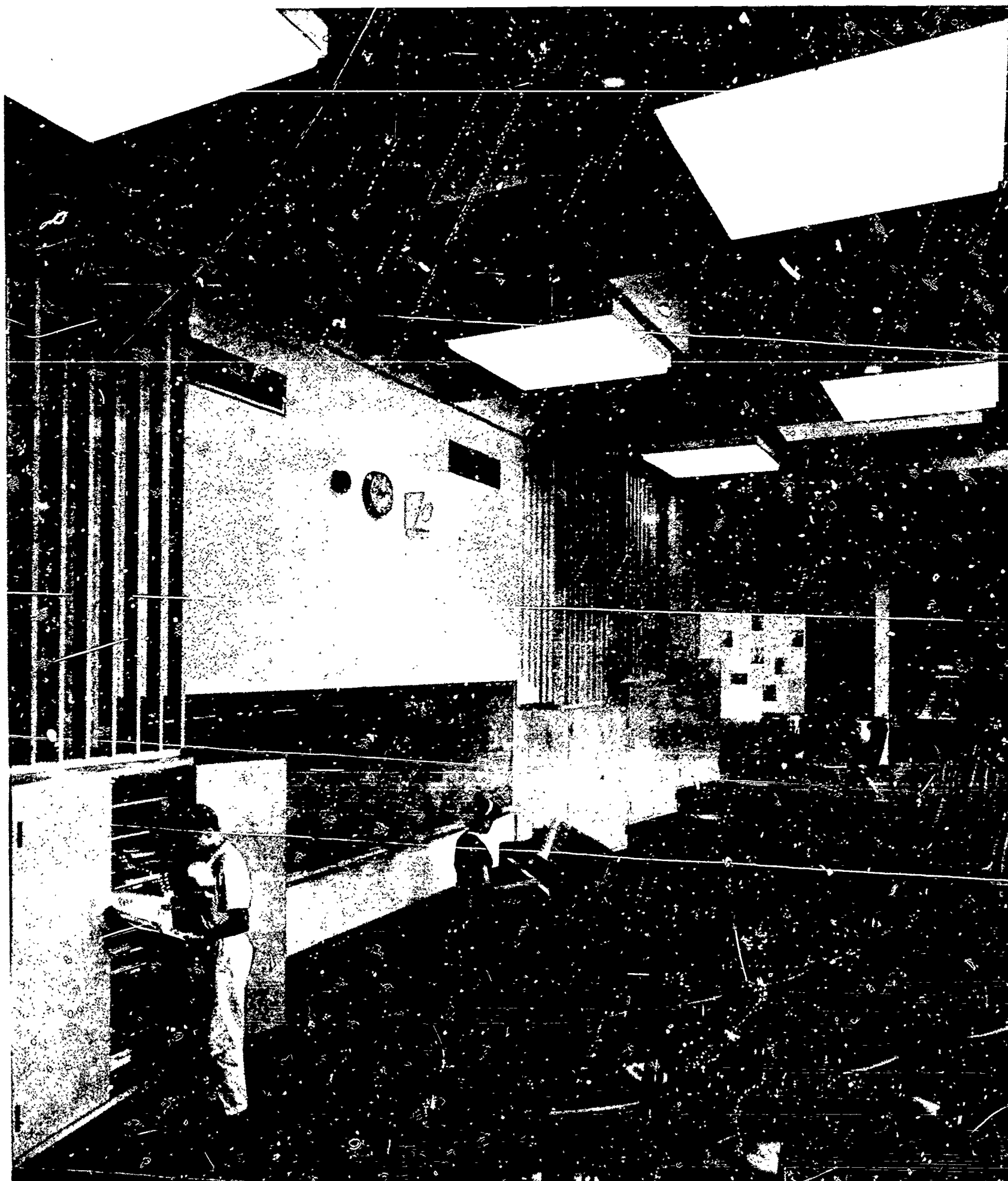

Rehearsal hall ceilings should have a mixture of sound-absorbing and sound-reflecting surfaces.

George Stately Junior High School

Rome, New York

Ferkins & Will, Architects

Robert W. Trowell, Associate Architect

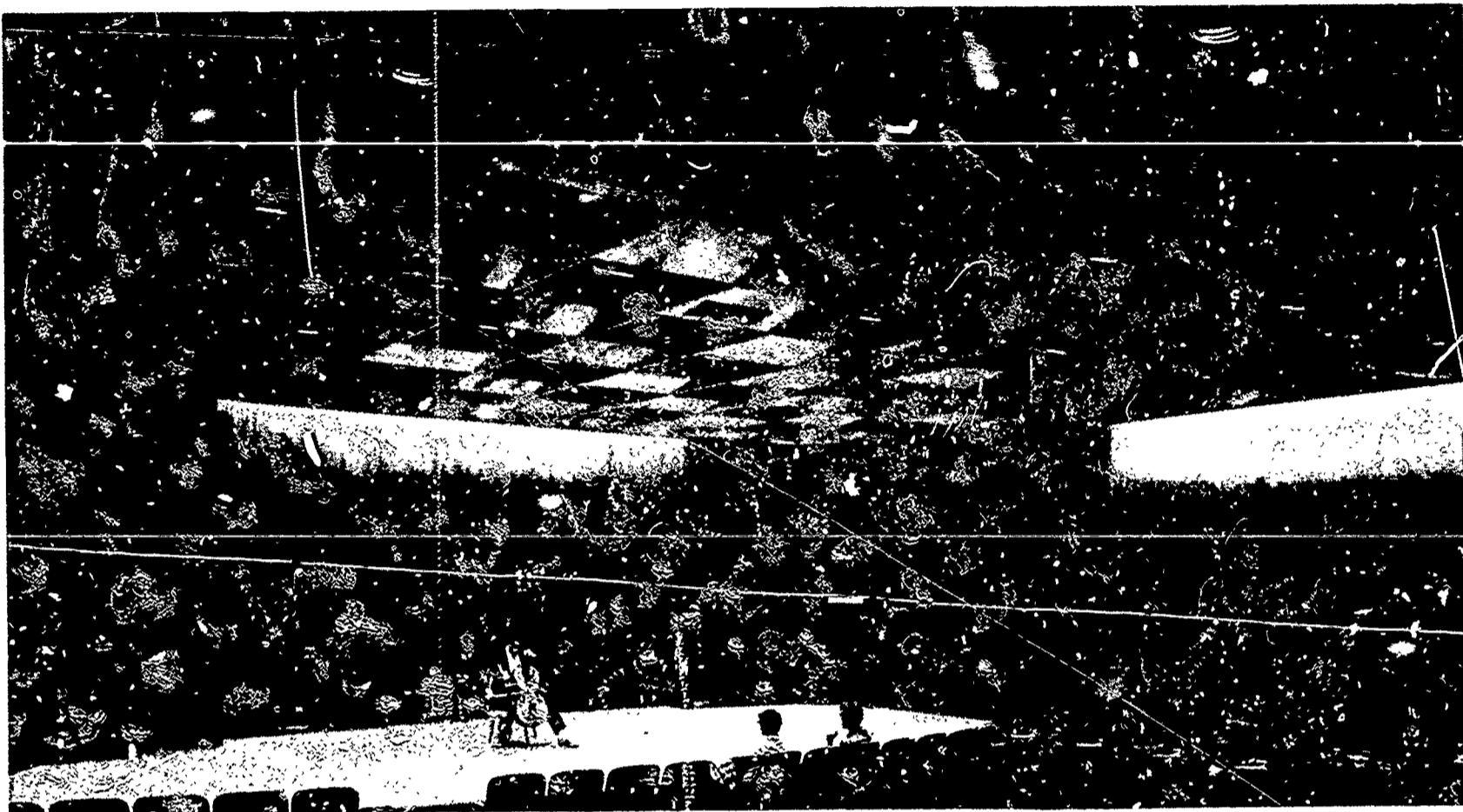

Walls and ceiling surfaces of recital halls should have irregularities to achieve sound diffusion.
Harper Recital Hall, Lawrence University, Appleton, Wisconsin
Frank C. Shattuck Associates, Inc., Architects

needs of the given situation, but a good rehearsal room is unlikely to be had with 9-ft. ceiling.

Recital Halls.—The recital hall generally seats from 200 to 300 people and will be used not only for performances but for rehearsal. The background noise from the air conditioning system and from other spaces should be inaudible. Here, a masking background noise would reduce the audibility of sounds we want to hear. Making the air conditioning system inaudible is not easy, but it can be done.

The recital hall should have an adequate ceiling height to establish the volume required to achieve a proper reverberation time. If an organ is to be incorporated, it may be desirable to provide heavy draperies, as suggested earlier for other spaces, to lower the reverberation time for piano and other instruments requiring a less live space. The chairs in the recital hall should always be fabric-upholstered (never leatherette), to give a reasonably constant reverberation time regardless of occupancy. The hall should be more or less rectangular, and circular forms should be avoided. The walls and ceiling surfaces should provide some degree of sound diffusion through irregularities. The stage area, in particular, should be so designed that there is good reflection of sound to the audience as well as to other performers

on stage. The ceiling height above the performing platform should not be more than about 20 ft.—it can be a little less than this—and the walls surrounding the platform should be skewed to avoid any parallelism. Some people express a prejudice for using wood as the finish treatment in such a hall, but equally satisfactory results can be had with plaster. There is little correlation between the use of wood in the construction of violins and in recital halls. The old-fashioned rococo rooms with heavily coffered ceilings, walls treated with niches and statuary and irregularities of all sorts almost inevitably resulted in good sound. We must find ways in our contemporary idiom to achieve these results.

Auditoriums.—The larger auditorium, whether it be designed purely as a concert hall or as a multipurpose auditorium in which music will be performed, poses problems considerably more difficult than those of the small rehearsal rooms or recital halls. Here, again, the requirement for absolute silence in the background must be very carefully worked out. If the program of uses indicates that fairly long reverberation time, say about two seconds, is desirable for organ and choral music, this will immediately demand a rather large volume for the space. Hopefully, such an auditorium will not be much larger than 2000 or 2500 seats, although larger and

successful auditoriums have been built. There are many possible arrangements of the audience in such an auditorium, and every effort must be made to give all of the audience good sight lines and to minimize the distance to the performing area.

Deep underbalcony spaces must be avoided, and every listener must be able not only to see the performers but also to receive reflected sound from a good part of the upper wall and ceiling area of the auditorium.

Once the seating geometry has been determined, the acoustics requirements can be incorporated in the design. These will determine the gross volume of the space for the achievement of the desired reverberation time, and the provision of adequate reflections from various surfaces in the hall to achieve the required intimacy and clarity, together with the overall fullness and warmth. The height of the proscenium opening will probably be determined by the need for an orchestra enclosure (somewhere around 30 ft. high at the front of the stage) and the need for a sound-reinforcement system. Loudspeakers for such a system should be located above the proscenium opening, never at the two sides.

Almost inevitably, the main ceiling of the auditorium will be quite high over the forward section of seating, and it will be necessary to add other reflecting surfaces at a lower height to give the required intimacy and clarity that come from early reflection of sound to the listener. The balance between the amount of early

sound (that received directly from the source and that received by reflections within the first 30 to 40 milliseconds after the original sound arrives at the ear) and the reverberant field which gives us a sense of fullness and warmth must be very carefully worked out. If there is too much of the early sound, the sound may be overly clear without enough body, and conversely if there isn't enough of this early sound, lack of definition and clarity will result. A good balance can be achieved, but its achievement will definitely dictate certain architectural details in the design of the auditorium.

Shells.—An orchestra enclosure is a necessity in a multi-purpose auditorium with a stagehouse. Some provision for a sound-reflecting ceiling must be made wherever there are to be performances by large groups of musicians. This ceiling should not be more than about 30 ft. above the floor. An orchestra enclosure can be made of plywood or steel or other fairly *heavy* sound-reflecting materials. Painted canvas is generally too lightweight to do an adequate job. There are no miracle materials for these enclosures, and, as in the case of sound transmission, the weight of the enclosure material will determine its reflectivity to sound. An orchestra enclosure is an *absolutely essential* part of a multi-purpose auditorium. It cannot be left as a piece of optional stage equipment though it has sometimes been omitted with disastrous results. An orchestra cannot per-

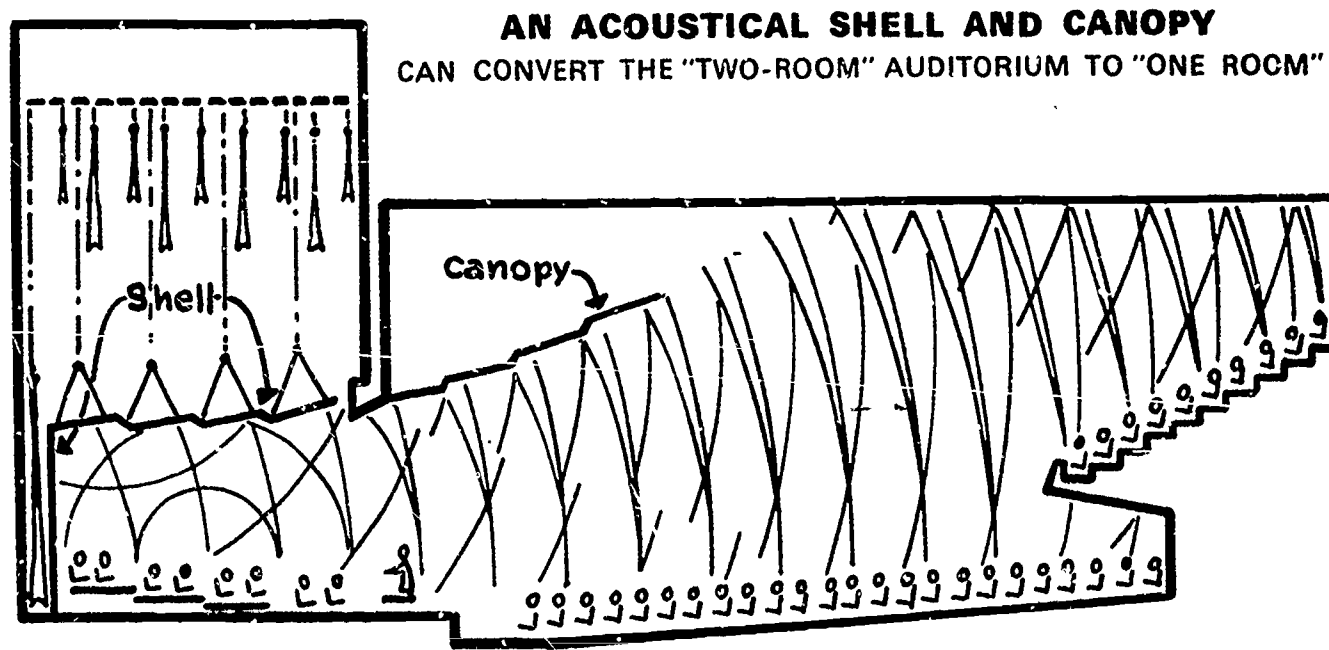

All areas receive sound reflections—the separate stage and audience "rooms" are connected acoustically and both are "live"

An orchestra enclosure is a necessity in an auditorium with a stagehouse.
Sketch courtesy of Wenger Corporation

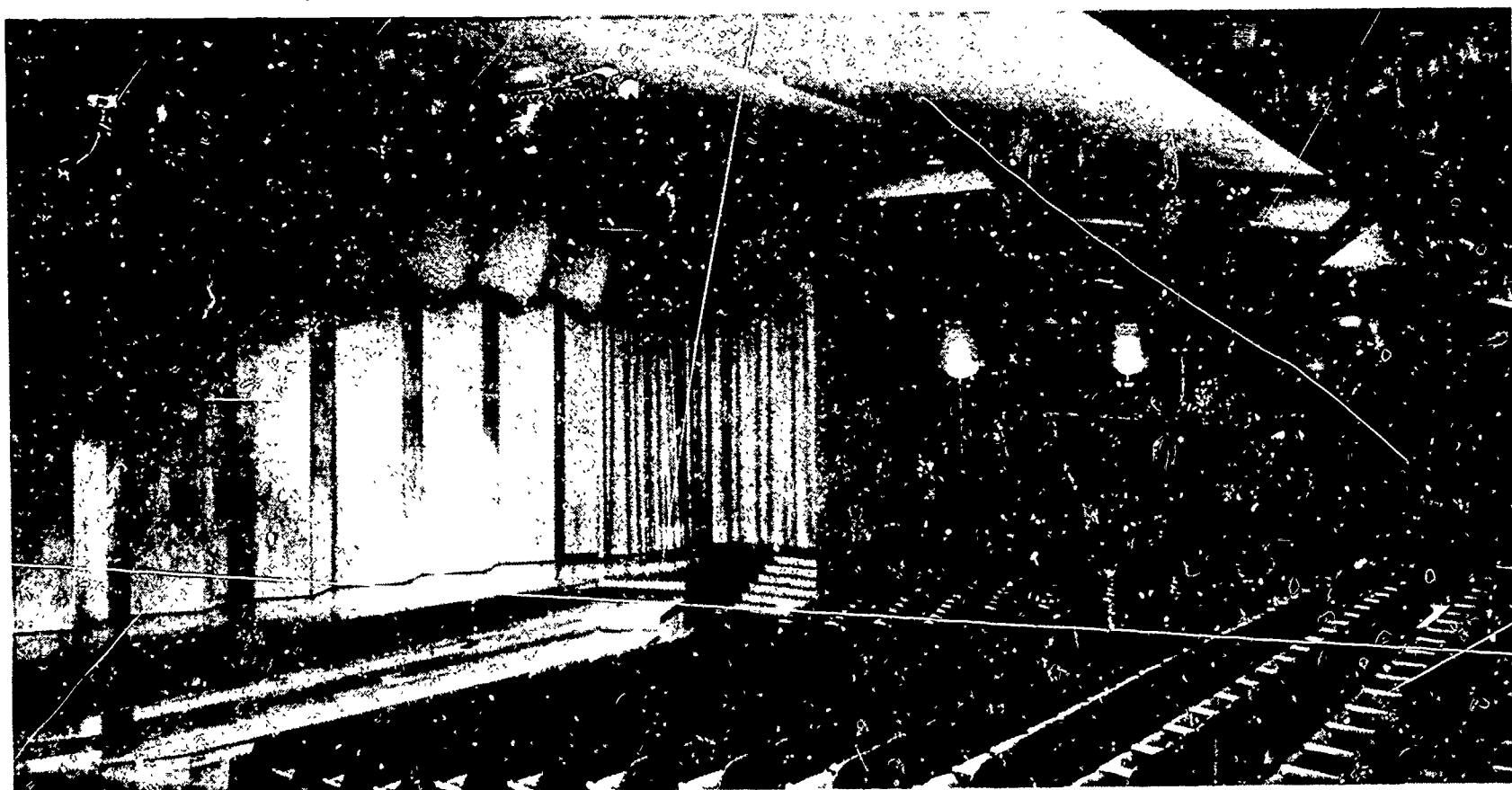
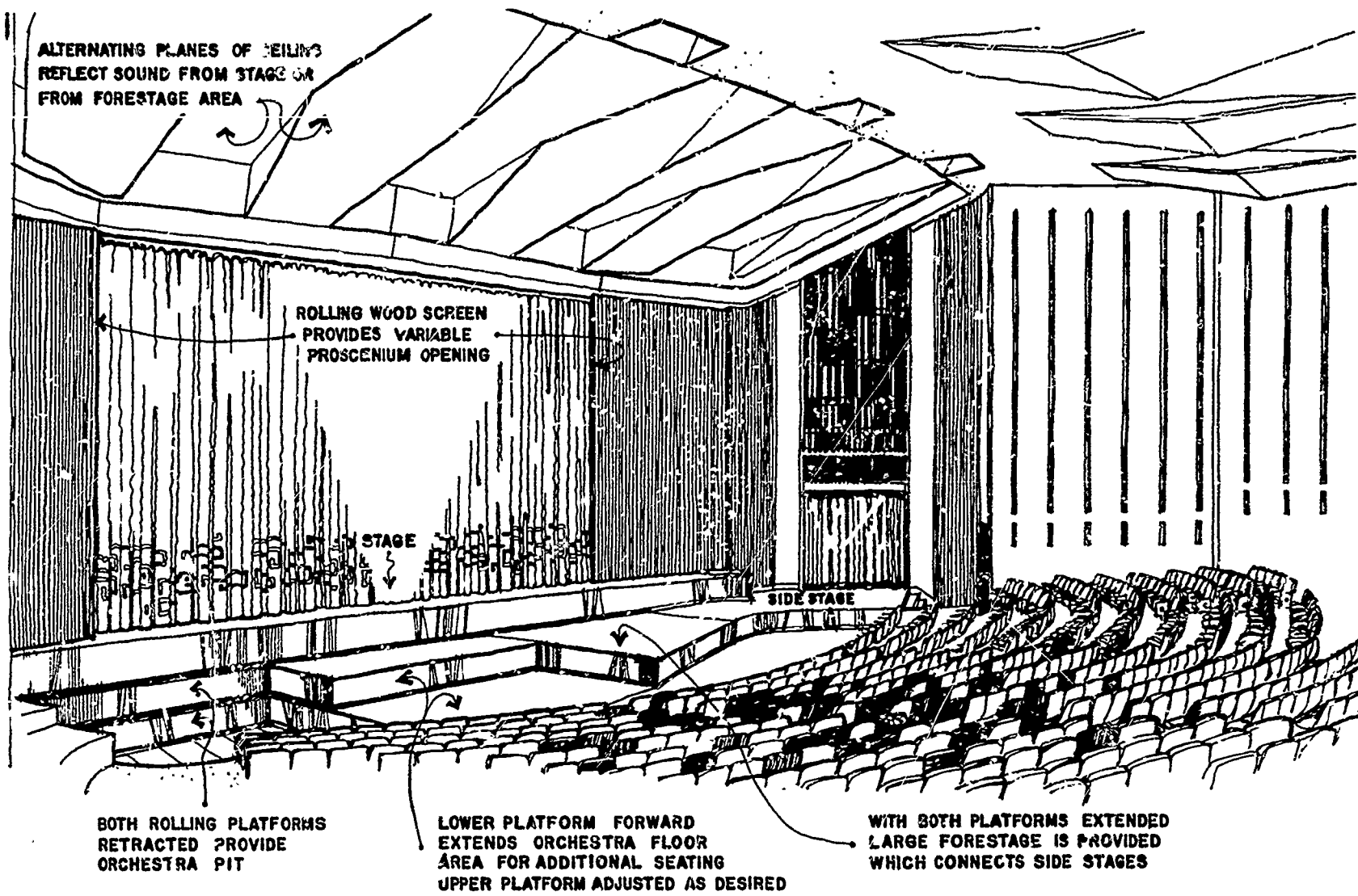

A large apron before a hard backdrop may enable a performing group to use the auditorium ceiling as its reflector.

Evanston (Illinois) Township High School (above)
Perkins & Will, Architects

Half Hollow Hills High School (below)
Huntington, New York
Daniel Perry, Architect



The orchestra enclosure in a stagehouse should be fairly tight with a minimum of openings to the backstage area.
Michigan State University
Shell by Stagecraft Corporation

form on a stage draped with velour and other sound-absorbing materials. The musicians will simply not be able to hear each other, and the projection of sound to the audience will be second rate.

When an enclosure is provided, it should be so designed that its erection or removal is quite simple and quick. This almost always means some mechanization of the handling system, although there have been some manually operated enclosures that have given good results. The orchestra enclosure in a stagehouse should be fairly tight with a minimum of openings to the backstage area. It should, in general, have sound diffusing surfaces and, if possible, some of these should be adjustable in orientation so that they permit various arrangements of performing groups and balance between various sections. If the ceiling is much higher than 30 ft. above the performers, there is almost always difficulty in onstage hearing.

A variation in auditorium design which permits orchestral performances without having a portable stage enclosure is that in which the orchestra performs in the front part of the hall itself in front of a hard backdrop (usually an asbestos curtain or a special sound-reflecting screen) and uses the forward part of the auditorium ceiling as its reflector. This, of course, means that the capacity of the auditorium is reduced when used for orchestral performances, but it does minimize the amount of backstage gymnastics to give the orchestra a good performing environment.

An orchestra enclosure or shell is also required whenever music is performed outdoors. The same general principles govern the design of these outdoor enclosures. The once-popular semicircular or parabolic forms for these shells should *never* be used. Any form of concave geometry will give undesirable focusing of certain parts of the performing group to certain parts of the audience

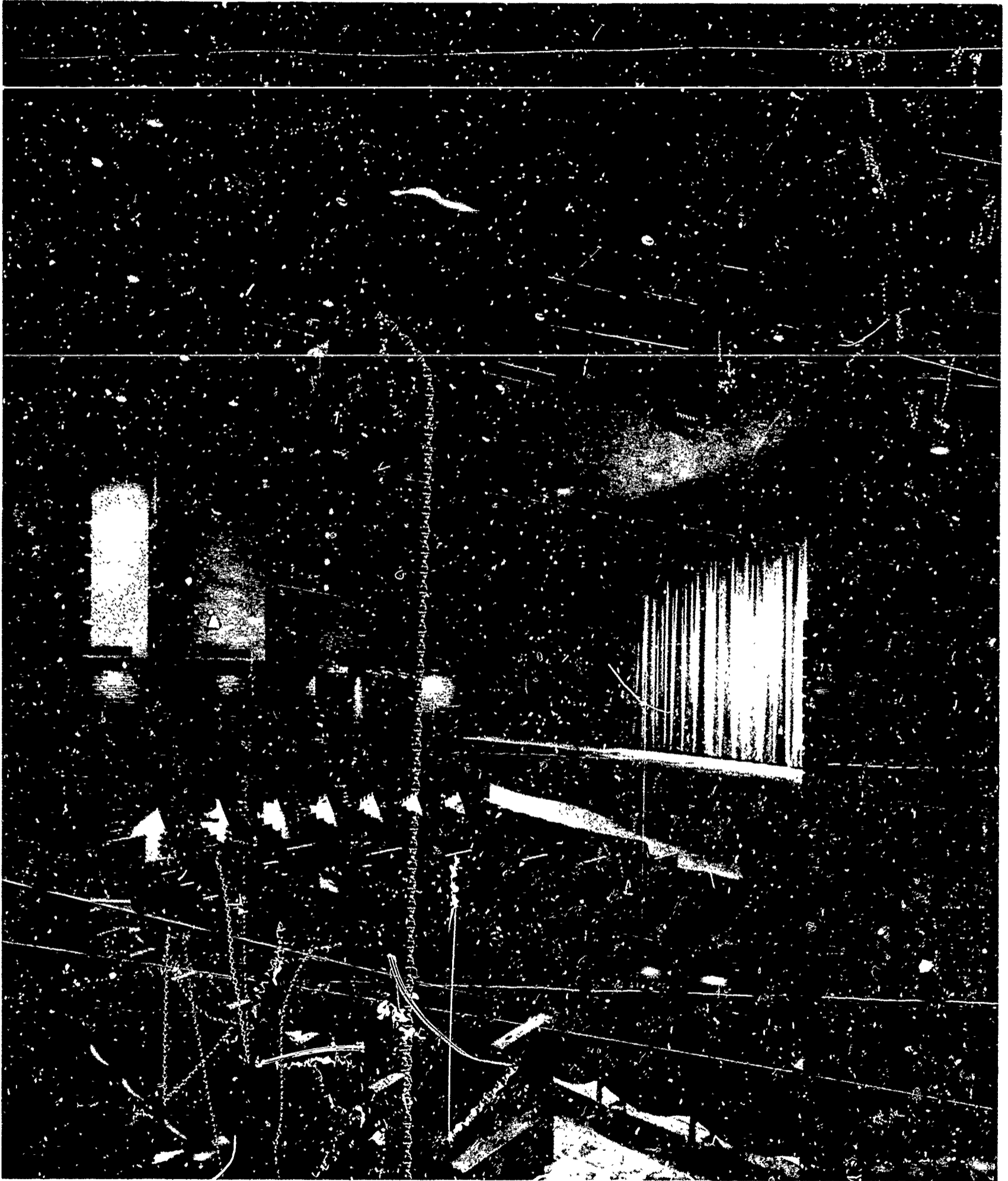

Loudspeaker systems should be located above the proscenium arch.
*Sycamore High School
Cincinnati, Ohio
Thomas J. McClorey & Associates, Architects*

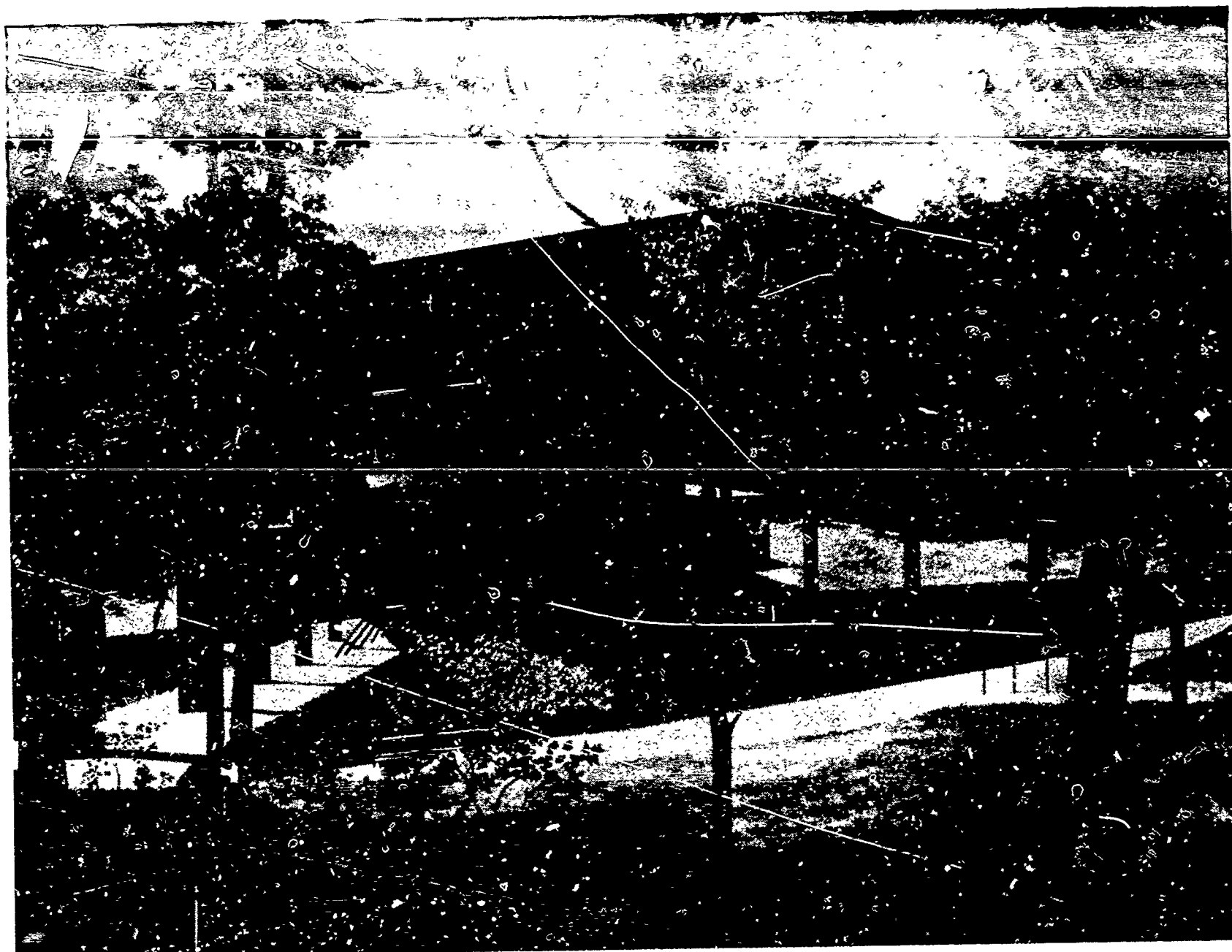

An orchestra enclosure is required whenever music is performed outdoors.
Howard C. Baldwin Memorial Pavilion, Rochester, Michigan
O'Dell, Hewlett & Luckenbach, Architects

This is inevitable. An orchestra enclosure should always be made of basically flat surfaces with modulations to encourage sound diffusion and more uniform distribution of sound to all of the audience from every part of the performing group. The exact shape of such an enclosure will be determined by the geometry of the seating area, but the greater the extension of the ceiling of the enclosure out over the audience, the better will be the result. This is usually limited by budget considerations. Shells can be built of concrete, steel, wood, fiberglass reinforced plastic or any reasonably dense, sound-reflecting material.

Amplification.—Although sound amplification is not usually an important matter to be considered for musical performance, a word or two of caution would be in order. Good sound amplification should be undetectable. One should not be aware of its operation, and the result

should merely be a slight increase in level of the natural sound. To provide this illusion, the loudspeakers must always be placed *above* the performing area, never at the two sides, and should be of only the highest professional quality. It is difficult to make a temporary installation that is really successful. In the large auditoriums, the loudspeaker system is always placed above the proscenium opening and will usually consist of a number of directional horns pointed toward different parts of the seating area. Loudspeakers in the ceiling are used only in the most exceptional situations, and when they are employed, time-delay loops must be incorporated into the system so that sound will not be delivered from them until it has reached the listener from the live source at the front of the room first. Otherwise, there is no illusion of realism.

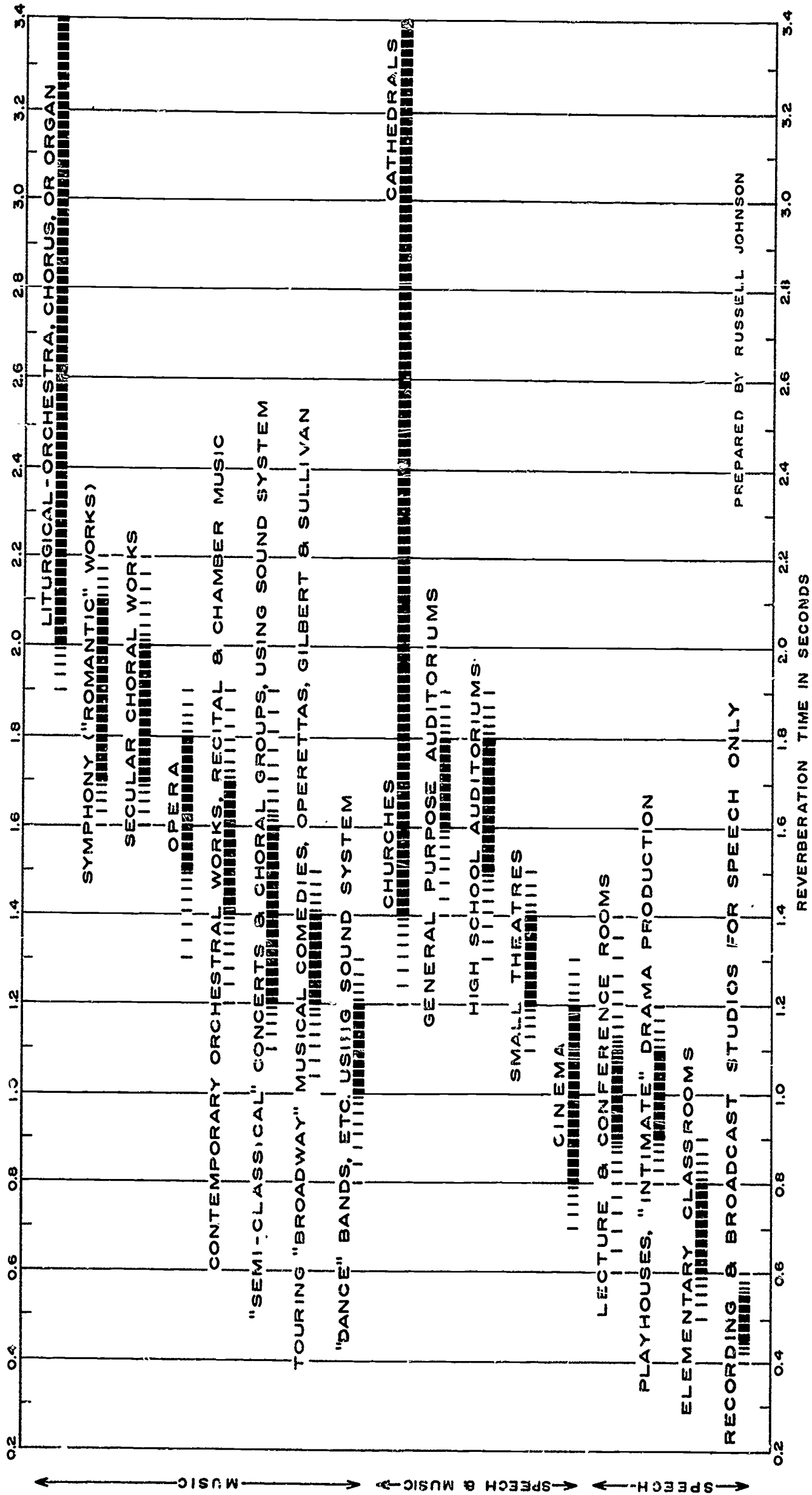

OPTIMUM REVERBERATION (500/1000 CPS) FOR AUDITORIUMS AND SIMILAR FACILITIES

One problem that always comes when one uses sound amplification is the necessity for placing microphones near the sources of sound. Microphones must be fairly close to the sounds being picked up and must be very carefully arranged to give good balance if more than one source is being amplified. For operatic and theater performances, a number of microphones can be placed in the footlights (with proper resilient mounting to avoid thumping sounds from people walking on stage), and the operator in the control booth must follow the performance and keep only those microphones live that are near the sources being amplified. For orchestra pick-up, additional microphones will be needed from overhead, and the relative operating levels must be adjusted

by experiment. Most musicians have rather strong prejudice against the use of any amplification, but this stems largely from the usual "squawk-box" or "battle-announce" loudspeaker equipment so often found. Really high-quality, professional grade equipment, operated by skillful hands, can in a difficult situation enhance the quality of almost any musical performance. This is especially the case in large convention halls or gymnasiums where musical performances are sometimes given and in the outdoors where the background sound level is not really minimum. The design of a sound system appropriate for a given situation is not a matter to be left to suppliers of equipment, however, and requires great skill in design, installation, and operation.

HEATING AND VENTILATING

As school buildings are being used during more of the year in all parts of the country, more and more of them are including air conditioning as well as heating as a part of their initial planning. Eight states (Alaska, Delaware, Minnesota, Mississippi, New Hampshire, New York, South Dakota, and Utah) reported air conditioning in 100 percent of the secondary schools completed in 1964.¹ There are a number of reasons why this makes good sense for music facilities.

The music room and auditorium are among those areas most apt to be used during the summer months by either school or community groups. Most music departments have a summer program of some type and the practice seems to be growing.²

Ventilating an auditorium can present a very serious problem. Though modern ventilating engineers now recommend considerably less exchange of air than that required by state building codes, the fact remains that six to eight changes of air an hour is a minimum figure and more than double this may be required in some auditorium situations in summer. The musicians' interest in all this is related to the fact that the air cannot be removed more than 300 ft. per minute (preferably 250 ft. or less) without creating noise. Furthermore, it must be moved much more slowly if there are many obstructions, bends, and louvers. Fortunately, ventilating engineers have adequate designs for solving these problems.

In moving air in an auditorium it must be remembered that air of low heat, 75 to 80 degrees, entering the audi-

torium will normally heat the auditorium to 70 or 75 degrees, but 70- to 75-degree air directed in any quantity upon an individual will be uncomfortably cold. It may be wise to heat auditoriums to within two to five degrees of the desired temperature before occupancy, since body heat will raise the temperature appreciably.

In changing the air within the auditorium, the change must balance the air changes in the stage areas so that the curtains on the stage do not billow. Musicians in the orchestra pit must be provided with adequate ventilation and yet slight drafts on instruments can throw them completely out of tune.

Sound isolation is an important factor in a music building and there is no way to isolate the sound if there are to be open windows. Air conditioning ducts must be treated acoustically to retard sound transmission

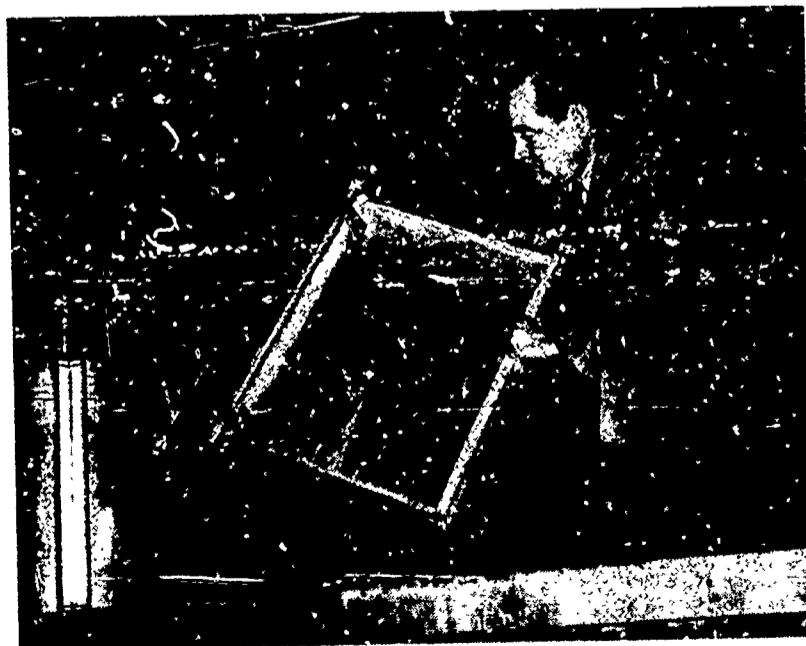

Air conditioning ducts must be treated acoustically to retard sound transmission.

¹ "Current Trends in School Facilities." *School Management*, IX, 7 (July 1965), 108-141.

² Corwin H. Taylor. "Prevailing Practices in the Supervision of Instrumental Music." *Journal of Research in Music Education*, X (Spring 1962), 30-38.

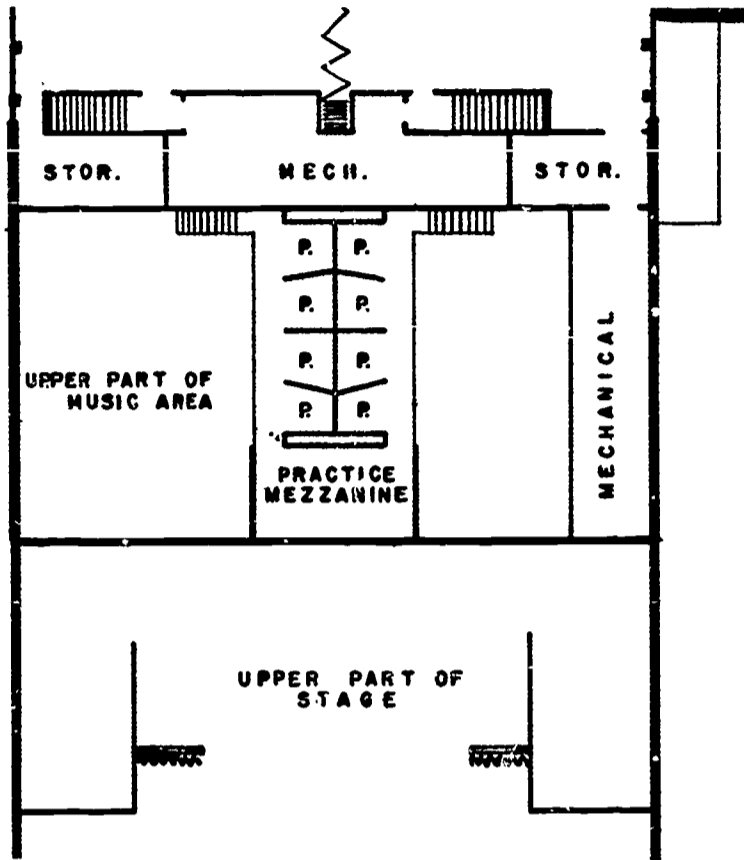

Air conditioning gives flexibility in locating areas such as practice rooms.

La Porte (Indiana) Senior High School
Perkins & Will, Architects

and it is true that this is expensive, but the same care is needed with ventilating ducts associated with the heating equipment. The cost of air conditioning is not prohibitive, therefore, since it must be figured as contributing to the objectives of sound isolation.

Humidity and temperature control are also important factors for music facilities. The pitch of a musical instrument is affected by temperature change, and the change in pitch per degree of temperature change is not the same for all instruments. A marked increase in the humidity can totally change the character of certain percussion instruments in the middle of a performance.



Humidity control is particularly important in areas in which any wooden instruments are to be stored.

Stringed instruments, including pianos, are especially sensitive to changes in humidity. Humidity control is particularly important in areas in which any wooden instruments are to be stored.

An adequate supply of fresh air is important to certain music activities, especially singing and the playing of wind instruments. The need for more than the normal supply of fresh air is a factor to be considered in planning rehearsal halls and practice rooms. Air conditioning also gives a great deal more flexibility to the architect in locating such areas as practice rooms which have no need for windows.

When the special needs of music facilities are considered, it does not seem reasonable to plan in 1966 without including air conditioning as part of the design. The first cost of proper heating, air conditioning equipment, and temperature control is small when compared to the benefits to be derived from a comfortable, invigorating environment for music education and from the savings to be effected by minimizing the deterioration of valuable musical instruments.

ILLUMINATION

Lighting systems for music rooms, in order to enhance the visual environment and to promote student visual efficiency and comfort, must be considered much more carefully than is done in the usual "fixtures and foot-candles" approach. Satisfactory lighting cannot be realized without awareness of the many and varied visual problems encountered in these multi use areas. Lighting

design and specifications for rooms should consider the following:

1. Visibility of music is seldom better than type-written material; it is usually poorer. Small details are important. Non uniform manuscript, wide range of inks and paper reflectances, size of music symbols, and lack of music printing standardization are current difficulties.

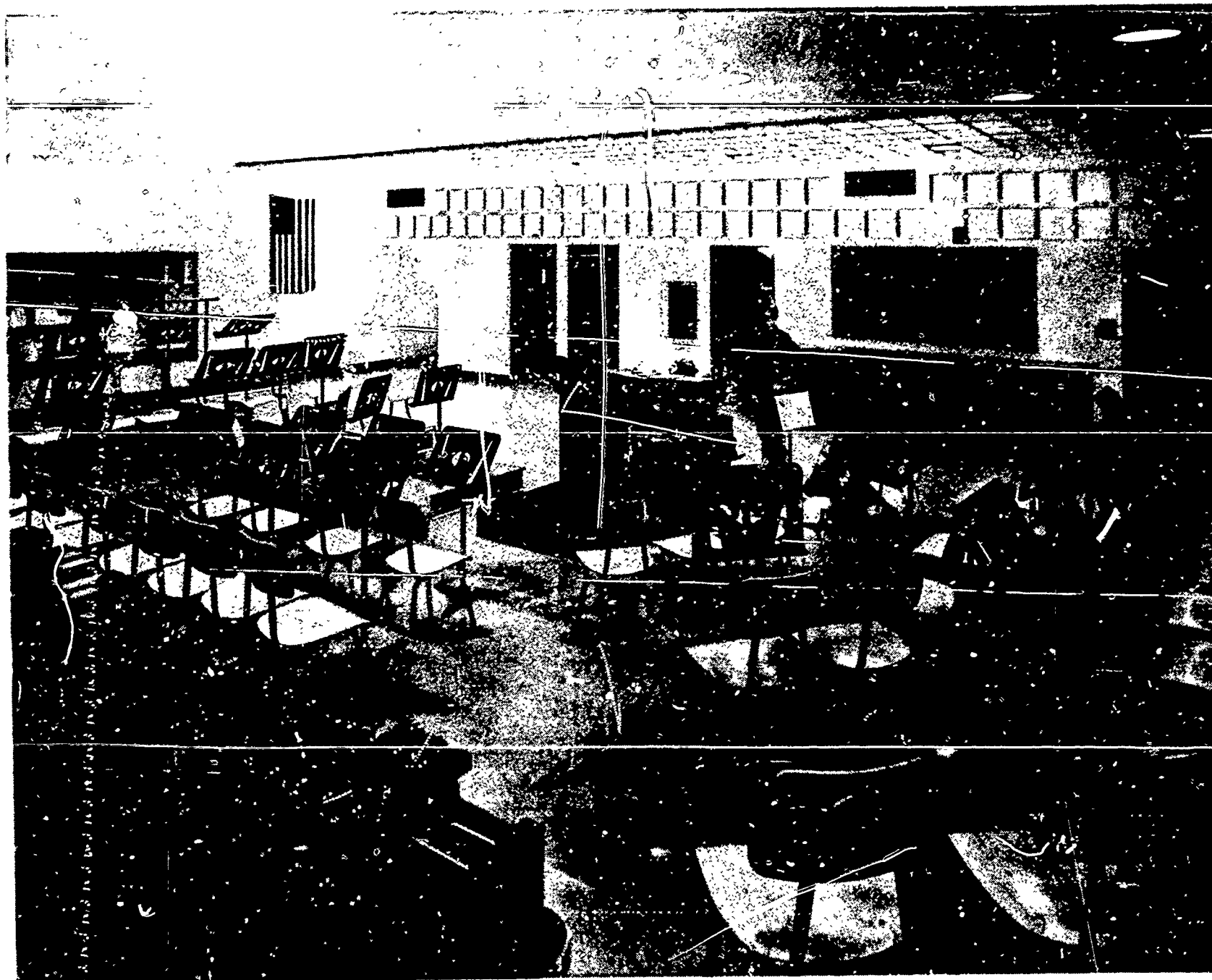

Posture is affected favorably by good lighting.
 Harold L. Richards Northeast Building, Oak Lawn, Illinois
 Nicol and Nicol, Architects

2. Distance of eyes to the printed page is influenced by the instrument played; and sharing of music often results in awkward positioning of the music. Visual comfort and efficiency is sometimes sacrificed for overall audience appeal in adjusting music racks.

3. Musicians are expected to read rapidly while also following the director's motions.

4. Irregular seating arrangements with students facing the director from various angles complicates the problems of eliminating glare and distracting objects.

5. Music rooms are equipped with furnishings which can create a condition of "visual clutter." Instrumental equipment such as horns, music racks, and folios is in this category and must be considered in the lighting plan.

6. Charts, diagrams, and details which each member of a large organization must see during rehearsal present a most difficult situation. These materials are usually displayed on a vertical surface where the light level is typically below that of the horizontal plane unless supplementary light is planned. The charts are often viewed from long range and at wide angles.

7. Music rooms are used day and night, winter and summer, for rehearsals, recitals, meetings, lectures, picture projection, and varied activities with many lighting requirements.

8. There is a natural tendency for many students to perform by ear rather than sight; good lighting encourages reading the printed page, which is a major music objective.

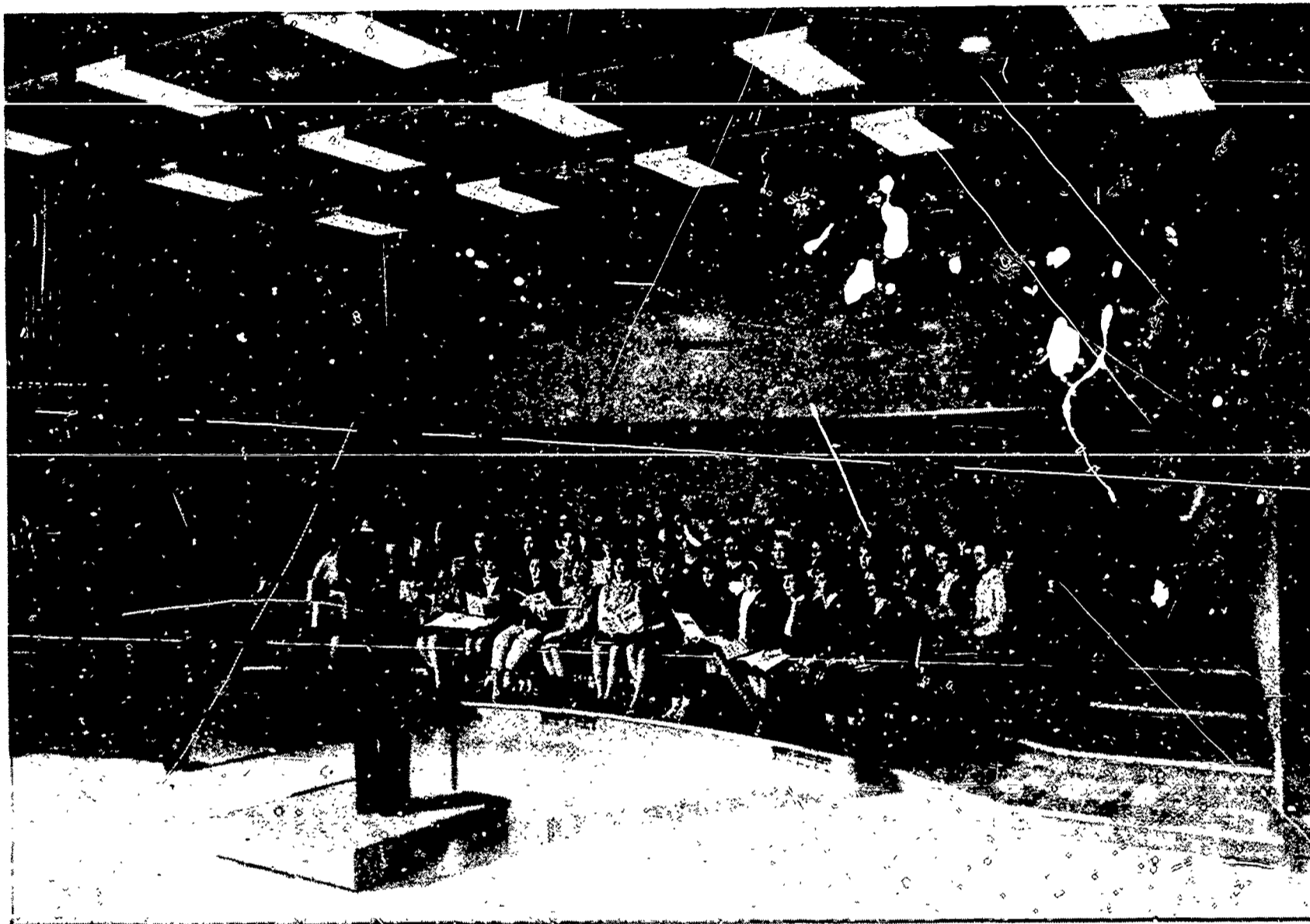

Music room activities indicate that levels in the 70 and 100 footcandle range should be used. Light colored flooring materials reduce the contrast with the printed page.
 Fine Arts Center, Knox College, Galesburg, Illinois
 Perkins & Will, Architects

9. Posture which promotes the best musicianship is affected favorably by good lighting.

10. Music classes are especially responsive to an appropriately planned environment.

11. Lighting engineers must consider that the man standing on the top rise is in a much different situation in relation to the light sources than the man sitting at floor level or standing on the director's podium.

COMFORTABLE LIGHTING

Comfortable lighting depends not only on the quantity of light, but the quality of the lighting installation and its relationship to the space. The quality and quantity of light are dependent upon several factors:

1. Controlling the illumination levels on the visual tasks (footcandles).

2. Keeping brightness of light sources within acceptable levels (footlamberts).

3. Controlling contrast and brightness ratios: (a) between light sources and ceiling; (b) between the printed page and the floor or walls; (c) between windows and walls; and (d) between music background and conductor background.

4. Providing proper diffusion—elimination of objectionable reflections, shadows and "hot spots".

Illumination levels for school tasks has been the subject of continuing research as shown in publications such as the *American Standard Practice for School Lighting* and the *Illuminating Engineering Society Lighting Handbook*. I.E.S. recommendations show 30 footcandles as a minimum for reading printed matter and 70 footcandles for reading pencil writing. The level is increased to 100 footcandles for drafting rooms or for areas where

poorly reproduced material must be read. Music room activities indicate that levels in the 70 to 100 footcandle range should be used. These levels should be made available by general illumination in the room and supplemented in problem areas with localized lighting. Flexibility in lighting levels and separate area control should be provided, especially in areas likely to be used by audiences attending recitals, lectures, or viewing films.

Brightness of the light sources is largely a matter of lighting fixture selection. Whether incandescent or fluorescent lighting or both are used, careful consideration should be given to the proper selection of materials for diffusers, fixture housings, shielding louvers, lenses, etc. There is no one "right" answer for the lighting of any space. With the thousands of fixtures on the market today it is easy for the average individual to be "sold" a type of lighting installation which may only come close to doing the job it should do. Characteristics of applicable light sources which should be considered in every installation include first costs, operating costs, ease of maintenance, repair and lamp replacement, size, appearance, color, heating effect, and noise level.

Contrast and brightness ratios must be controlled to aid visual comfort and efficiency. Suggested maximum brightness ratios of the order of 3 to 1, 5 to 1, etc. appear in the various I.E.S. recommended practices. These values depend upon the severity of the task. Some examples of high brightness ratios with possible corrections would be as follows:

1. Recessed troffers in ceiling, widely spaced, emit only down-light. This could be improved by closer spacing and by the use of drop-dish diffusers, instead of flat, to emit sidelight and illuminate the ceiling, thereby reducing contrast.

2. High level of illumination on the white printed page gives marked contrast against the background of a dark-colored floor. Flooring materials such as tile and carpeting in lighter colors should be used.

3. Dark sidewalls with small windows result in undesirable contrast. Better solutions might be had with larger windows, no windows, light-colored diffusing drapery or blinds, or wall-washing type lighting fixtures around the perimeter of the room.

4. Music rack surfaces facing the student often form the visually adjacent area to the music being read and should be limited to a brightness ratio with the music of 3 to 1. This indicates light, non-glaring finishes on the music rack face. Music folios in light neutral colors would meet the limits of this 3 to 1 brightness ratio,

and would provide a reading condition comparable to the light work surfaces of modern desktops. The front side of the music stand is often in the field of vision of another player and should be finished to blend with the surroundings. The appearance of the stands and folios to the audience when the group appears in concert is a factor also to be considered. Furnishings for music rooms should be finished to meet the recommended reflectance range. The floor is also in the field of view of the student and should not be too dark. Green chalkboards have shown a popularity and growth parallel to the light finished desk; they are easily held in line with the recommended brightness ratio of the board with its wall background. Boards with higher than 20 percent reflectance reduce the contrast of chalk with the board, and visibility of chalk marks accordingly suffers. Steel chalkboards with fired abrasive enamel surfaces enable small magnets to be used to post bulletins and demonstrate band formations.

Proper *diffusion* of the light is a function of the type of shielding or materials used as diffusers on the fixtures themselves, the number and distribution of fixtures and the selection of light-colored matte-finished materials for walls, furnishings, and equipment which will reflect light without glare. This will help control reflected brightness which is just as much a problem as direct brightness. Some recommended reflectance values are shown in Figure 12. (Note: the photograph is not intended to show a necessarily good lighting installation.)

Unilateral daylighting as provided from windows at one side of the room is included in many room plans. While popular and practical, it does involve inherent problems such as:

1. Natural light is not dependable (cloudy days).
2. Sunlight is not available at evening and night rehearsals.
3. Students near the windows may have very high levels of light (100 footcandles or more), with levels falling off rapidly to the inside rows where you may find less than 5 footcandles on a bright day.
4. Windows which serve some students well as a light source often are a source of glare and discomfort to the director or others in the room.
5. At night windows usually become dark areas to those within the room. Proper shades are usually the answer to the last two considerations.

Clerestory or multilateral daylighting plus light floors raise the ambient interior brightness to offset high indoor-outdoor contrast. Without well-planned daylighting, space may need more electric light during the day than at night. Problems exist also because of building orienta-

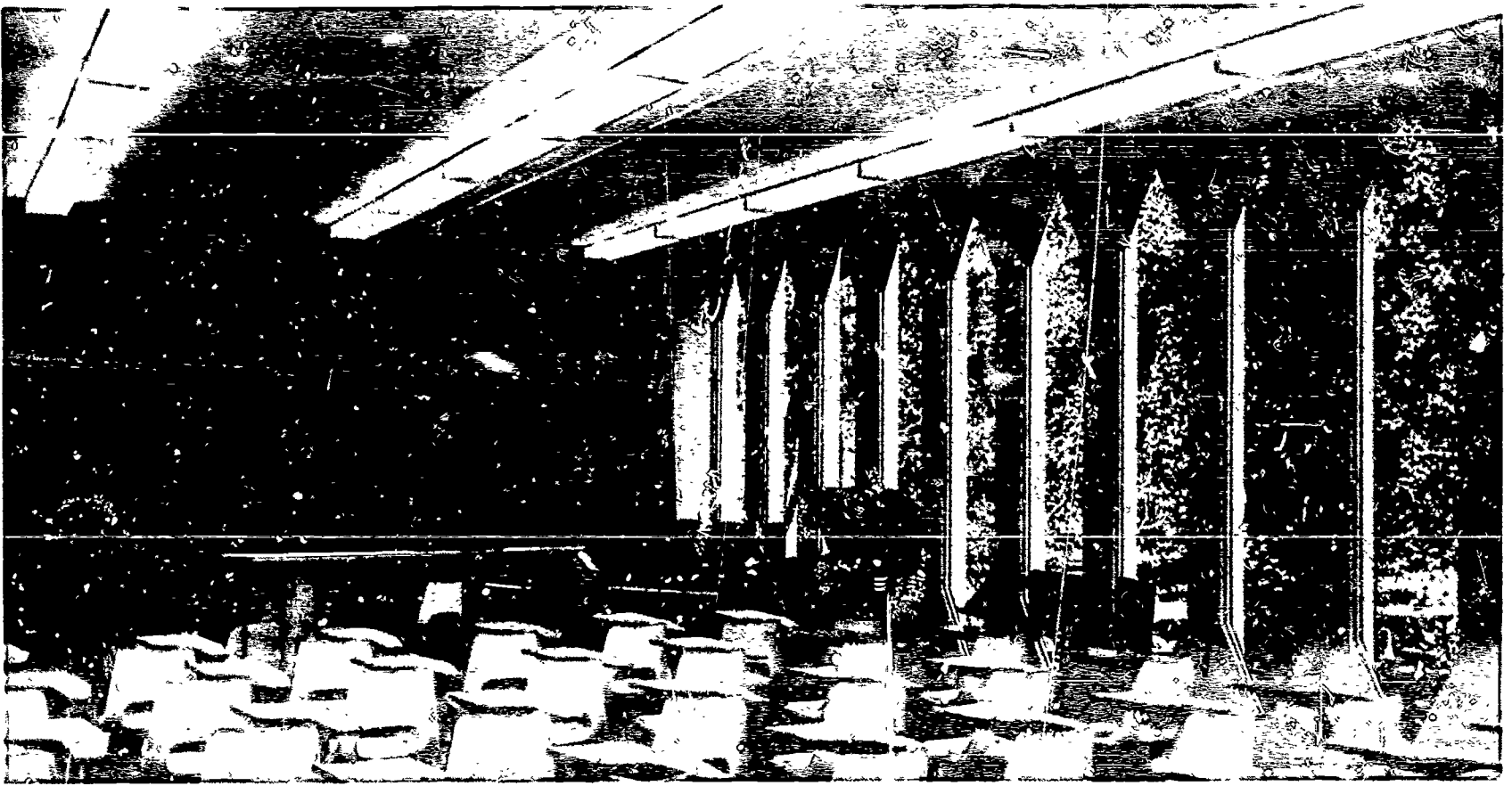

Windows may be important light sources providing proper consideration is given to weather conditions, architectural design, orientation, fenestration, and relationship of rooms to other buildings or plantings outside.
Oberlin Conservatory of Music
Minoru Yamasaki and Associates, Architects

tion. Windows might be hit by direct sunlight instead of being protected by overhangs or sun control devices or faced to north where protection is unnecessary.

Windows may be important light sources providing proper consideration is given to weather conditions, architectural design, orientation, fenestration, and relationship of rooms to other buildings or plantings outside. However, in many recent school designs, music rooms as well as lecture rooms and auditoriums have been built without windows. This can simplify the design of the lighting system by eliminating many of the problems mentioned above. In addition to the lighting considerations, there are other good arguments for the windowless music room, such as the growing use of year-round air conditioning, simpler acoustical control, easier adaptability to use of visual aids, and elimination of distractions. Proper uses of lighting and different building materials as well as color (which will be discussed later) can eliminate the possible "closed-in" feeling of such rooms.

The selection of lighting systems and planning of the installation should be done by the architect with the aid of a competent illuminating engineer or lighting consultant. Power and light companies and equipment manufacturers are additional sources of information which these people use. By coordinating the efforts of

all of these people proper considerations can be made of the visual needs, initial costs, energy rates, operation and maintenance costs, and architectural design. The resultant effect should help assure satisfactory illumination of the music room and its specialized areas.

LIGHTING MAINTENANCE

Particular attention should be given to adequate maintenance of the lighting system. Without a planned program of periodic fixture cleaning and replacement of lamps, illumination levels can drop to half of the installed values in a few months. In auditoriums or other high-ceilinged rooms where scaffolding is required to replace lamps, it is more efficient to replace all lamps at one time. Lamp life can be predicted accurately and a relamping and cleaning program for the school should be planned for vacation periods at intervals which approach the useful life of the lamps. The typical school usually replaces a lamp when it burns out, which becomes a constant operation with resulting poor architectural appearance and inconvenience to students and teachers as well as an extremely inefficient lighting system.

Care should always be taken to relamp fluorescent fixtures with the proper color of lamps also. Illumination levels as well as colors of walls are greatly affected by the choice of fluorescent lamp color.

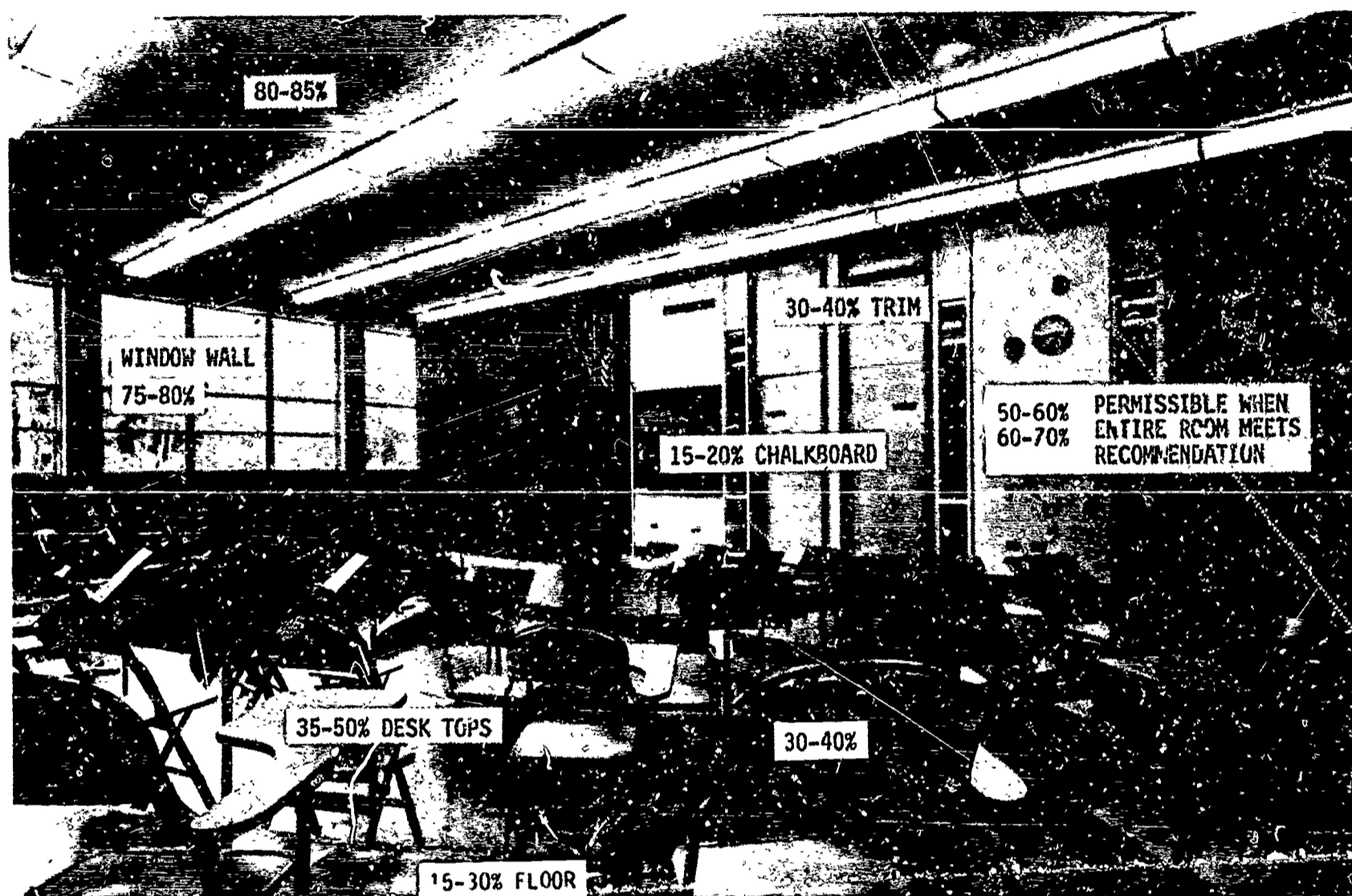

Figure 12. Recommended Reflectance Pattern for a music room.
 Pearl River (New York) High School
 Caudill, Rowlett, and Scott, Architects

COLOR

In order to have better teaching facilities, we need not always think in terms of expensive equipment, and plush building materials. Attention to small details often is neglected in the rush to take advantage of the larger or seemingly more important phases of a building project. In many cases good design involves little or no additional cost and can quite often save money in future maintenance or the avoidance of corrective measures. One of these "small details" is the selection of proper colors for all areas. This selection, whether done by an interior decorator, a color consultant, a school committee (hopefully not), or the architect should be based upon careful consideration of the following factors:

1. It is a well-known fact that color affects and influences human beings of all ages. Scientific tests have shown that some colors stimulate and excite. Others soothe and relax. Still others create fatigue, depression, and irritation.

2. More and more, educators and school authorities all over the country have become aware of the important part color plays as an aid in creating an atmosphere that promotes efficiency and morale among pupils and teachers alike.

3. Selecting colors for schoolrooms which merely seem to be attractive, may force those who occupy these rooms to work and study in surroundings that are psychologically unsuited to them. Such surroundings may gradually get on their nerves, affect their work, cause them distress and unhappiness.

4. Elimination of these adverse conditions not only stimulates energy and improves concentration, but also raises morale. Color can help to bring about a better spirit among teachers and students, improve their spirit of cooperation and loyalty.

5. The correct use of color, combined with proper maintenance, gives teachers and students a feeling of pride in their surroundings and fosters a desire to assist

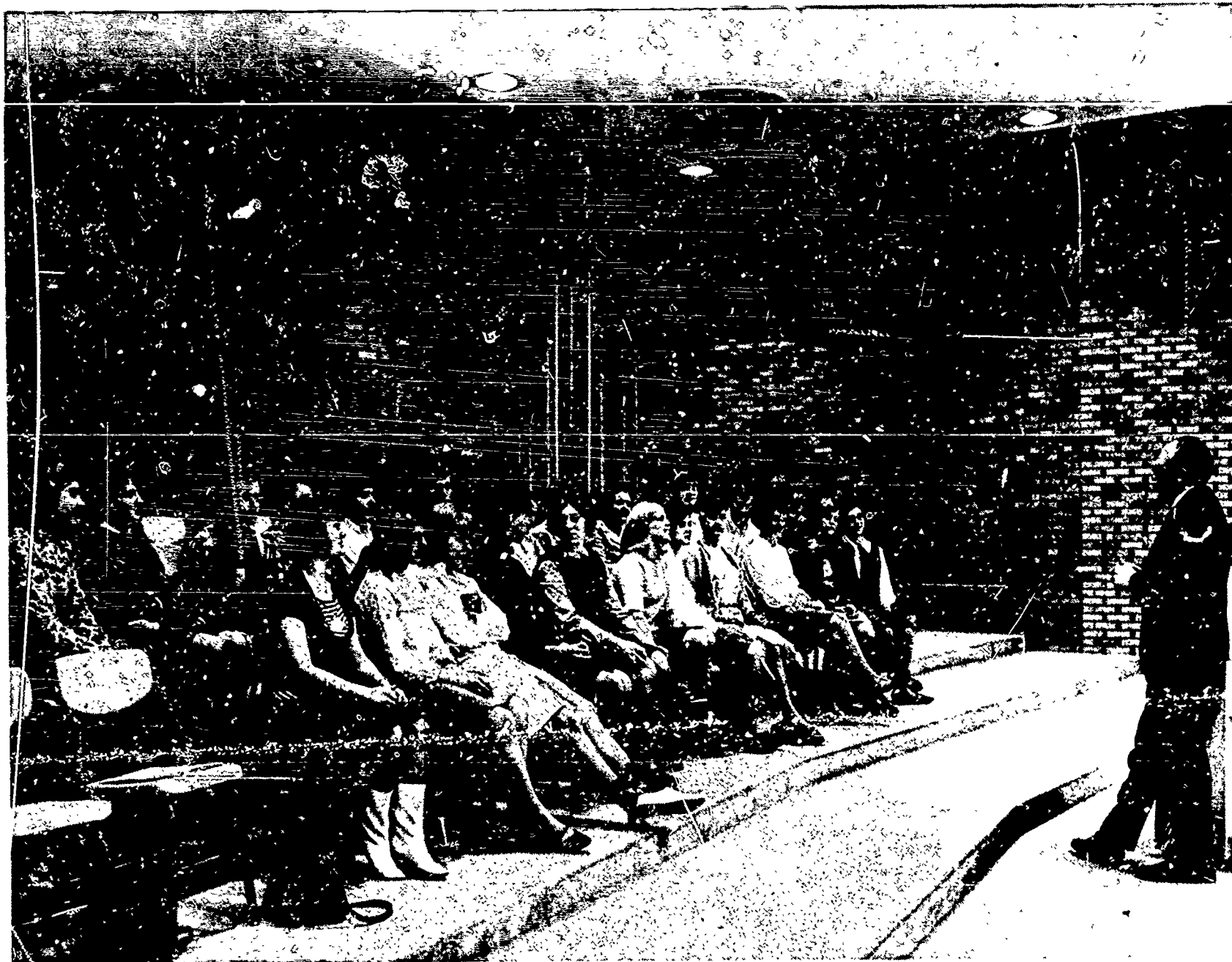

Teachers should not be forced to look into strong light.
 Harding Senior High School, St. Paul, Minnesota
 Haarstick, Lundgren and Associates, Inc., Architects

in keeping them neat and orderly. Selection and placement of colors should be in keeping with their function, exposure to sunlight, and available lighting facilities.

WARM AND COOL COLORS

Gray shades would meet specifications as to lighting reflectances needed to provide adequate illumination levels but the rooms would not be popular—people like color. Color recommendations are generally based upon the psychological effect of the various colors. For example, the blues and greens which we associate with the sky, lakes, and trees are considered to be cool colors. They are frequently recommended for west and south exposure rooms which may feel overly warm due to sunshine. On the other hand, the creams, corals, peaches, and tans

are warm colors. They are frequently recommended for north and east exposure classrooms. The cool, light pastel colors are receding colors and tend to make a room seem larger. The reverse is generally true of the warm colors. Greens, especially blue-greens, are quiet colors and people seldom object to them, hence they have wide use.

DETERMINING THE VALUE OF COLORS TO BE USED

Color value, that is light or dark color, is important in two ways for schoolroom decoration. The first rule is rather obvious—that the lighter values should be used in rooms which tend to be dark, thus securing the maximum of reflected light. Lighter rooms may have darker walls, and in the case of rooms receiving strong glaring

light, the colors of medium or darker value reduce the strength of the reflected light. Color values have additional powers, such as changing the apparent proportions of rooms. They may also be the means of equalizing the distribution of reflected daylight in a room. Both of these functions are dependent on the selection of the right color values and involve the additional problem of their correct placement in the room.

Light and dark values of color can be used in changing the apparent proportions of rooms. Sometimes it is desirable to equalize the dimensions of a long, narrow room. In this case, the end walls are painted in a relatively dark color, a lighter value of that color, or a harmonizing hue being used on the long side walls. This placement of light and dark values is based upon the fact that in juxtaposition to each other dark colors seem to advance and light colors to retreat. Thus the length seems diminished and the width increased.

In square or nearly square rooms the lack of interest in proportion is often made less apparent by painting one wall a different hue than the other three. This concentration of interest on one wall makes the fact that all walls are of the same approximate dimensions less noticeable. If the window wall is used for this purpose it should be lighter than the others, and if the opposite wall is used, it will be darker than the other three, in accordance with the rules for equalizing light.

THE PLACEMENT OF COLORS

It is desirable to secure variety throughout the school being decorated by the choice and placement of colors. The avoidance of monotony is vital and the use of more than one wall color is often advocated. Some areas call for stimulating colors while calm, soothing colors are more appropriate in other places.

In classrooms devoted to certain subjects it is highly important to secure and retain the attention of the pupils where the instruction is being given. One can meet this problem with a functional application known as a focal wall. The focal wall is painted a darker or lighter value of the color used on the other three walls, or a contrasting color—one which will focus the attention of the students on that part of the room, and, at the same time, not be conducive to eyestrain. A darker color is most often used for establishing the focal wall, since a slightly darker value is usually more restful than the lighter colors surrounding it. In this case the same color may be repeated on the lower portion of the other three walls, where there is a dado or wainscot.

An important consideration should be the atmosphere in which teachers work. They should never be forced

to look into strong light. Wherever possible a wall painted in an eye-rest color should face the teacher. In cases where a focal color is used on the front wall, the same color should be used on the opposite wall for this purpose, provided the teacher faces it often.

The light in some classrooms, coming from only one direction, seems particularly strong and concentrated on the wall opposite the window wall. The reflected light in such a room is often equalized by the use of wall colors in three values. The darkest color is applied to the wall opposite the windows where the light is strongest. The two end walls, which receive slightly less direct light are painted in a lighter value, and the window wall which receives little or no direct light is painted in the lightest value of the three.

It is preferable, in the average classroom, to finish the ceiling to reflect the maximum amount of light. This restricts the range to white, soft white, cream, ivory, or a very pale tint of a wall color, or a contrasting tint. Such colors should have reflection factors within the range of 80 percent to 85 percent.

In other rooms in the school where the maximum amount of light is not required to be reflected from the ceiling, a more pronounced color is not only effective from a decorative standpoint but may also serve a definite purpose functionally. In a cold north or east room a ceiling in sunny yellow or peach will serve to give a cheerful effect to the entire room. The glare of west or south light in rooms facing those directions may be counteracted effectively by using light green or blue-green on the ceiling.

SELECTING COLORS

The choice of colors for the average classroom depends not so much upon the use of the room for instruction in a particular branch of learning as upon other factors such as exposure, amount of natural and artificial light available, proportion of the rooms, need for focal wall or three-value walls, and similar considerations. The age of the students should also be considered. The subject being taught might also influence color choice, though many schools, particularly the smaller ones, use classrooms for instruction in more than one subject.

Other rooms in the school building require definite color treatments based upon their uses.

Auditoriums.—An auditorium in a school serves as a lecture hall, concert hall, theatre and assembly room. Painting an auditorium is purely a decorative problem, and its decoration depends entirely upon its architecture and the colors of the objects that are present and cannot be changed, for example: the stage curtain, drapes, sets

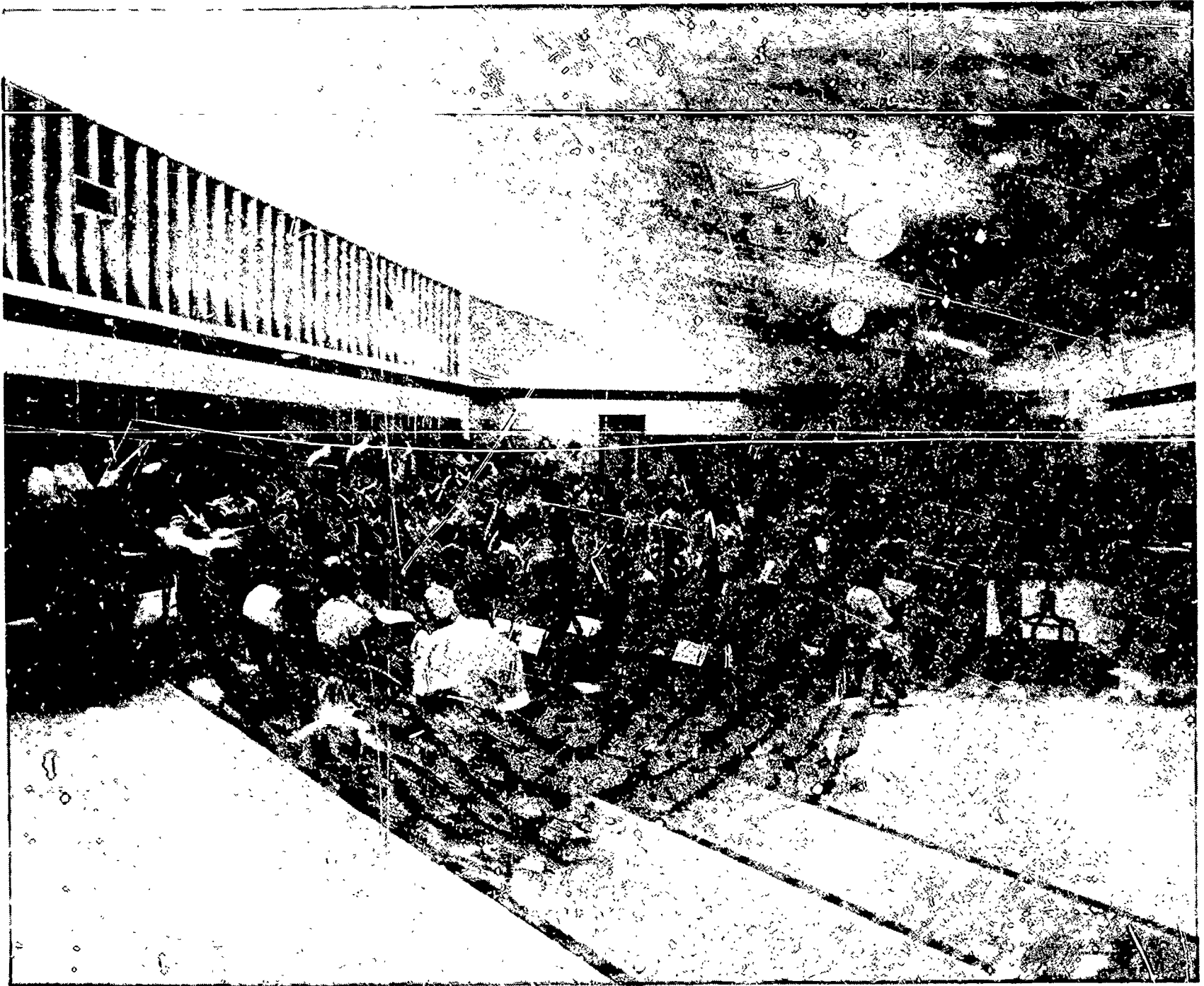

The ceiling in the average classroom should reflect the maximum amount of light.

*La Junta (Colorado) High School
Shaver & Company, Architects*

and floor. There are a few general rules that might be well to keep in mind. If the auditorium is small, it is advisable to use cool receding colors for walls and other vertical areas, such as shades of green, blue, and so forth, with the ceiling in a contrasting warm hue, such as rose or yellow. For the larger auditorium warm colors may be employed or a variety of warm and cool colors.

Music Rooms.—A music room may well be treated as a room of some stimulation, employing warm and cool colors. Consideration should be given to the color of walls adjoining chalkboards, to the color of the boards themselves, and to the walls behind the conductor which might be sources of eyestrain if too much contrast is

present. The student is constantly looking up from his music to the board during lectures or to the conductor during rehearsals and performances.

Offices.—Offices should be dignified and conservative, making use of the light at hand, both natural and artificial, for the eye comfort of the workers. Where the light is of higher intensity than required, colors having lower light reflection factors should be used. Where the light is adequate or slightly on the low side, the color should have a higher light reflection factor. This is merely balancing color with light. Where direct or semi-indirect lighting is used the ceiling should be finished in white.

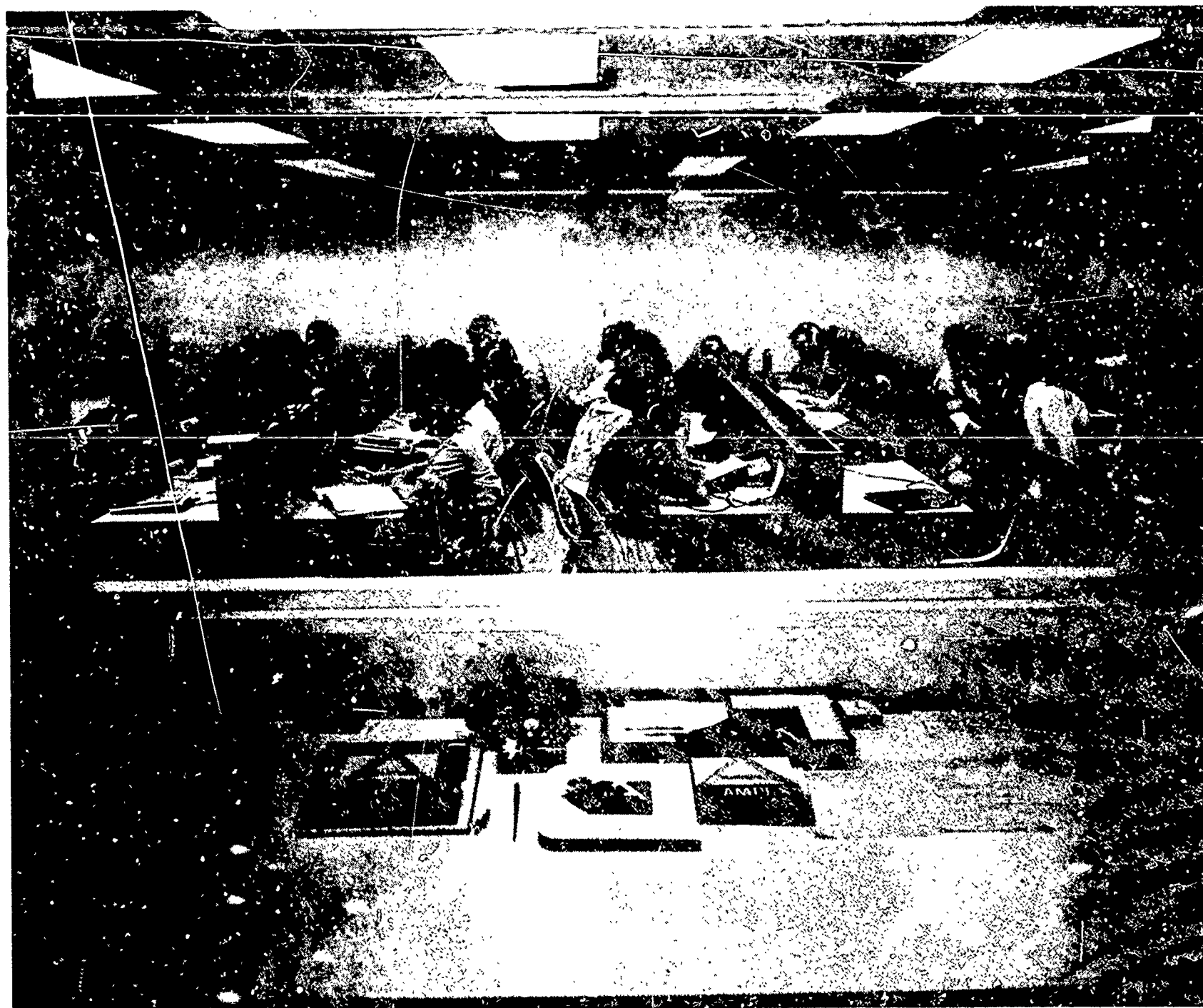

Music listening stations should provide high quality earphones.
Listening Center
University of New Mexico, Albuquerque

Assembly Rooms.—Rooms where the students are occasionally gathered together should have an atmosphere as different as possible from that of their classroom activities. The background of color should not only be restful and relaxing in feeling, but should put the student in the proper mental attitude to participate wholeheartedly in the activities of the assembly.

RELATIONSHIP OF COLORS TO THE LIGHTING SYSTEM

An important factor in the selection of colors is the original and maintained relationship with the lighting system. Fluorescent lamps come in a wide variety of colors. The most commonly used are the white, cool

white, deluxe cool white, warm white, and deluxe warm white lamps. The original intention of a color scheme in a room can be lost completely by changing types of lamps in the lighting system. Colored light affects colored paints in ways which are unpredictable to the average person.

Many times a room is repainted without regard to physical or psychological needs simply because "we have some of this color left—let's use it, or here, pour in some of this and we can do two more rooms!" The point being made, of course, is to keep a coordinated maintenance program of lighting and decorating which recognizes that the two are not independent considerations.



Electrical needs of the future should be planned into present buildings.
 Television Engineers' Room
 Tawes Fine Arts Center
 University of Maryland

ELECTRICAL INSTALLATIONS

Most of the electrical considerations within the concern of the music educator are dealt with in the chapters on the Auditorium and Equipment. The architect and electrical engineers will take care of most other matters such as making certain that the electrical needs of the future are planned for by making conduits oversize and easily accessible. Safety recommends the grounding of all outlets.

Music educators will have special interest in seeing that electrical equipment such as the lighting system does not interfere with the reproduction of sound. Fluorescent lighting will need to be provided with ballasts that will not cause interference with the sound equipment.

Listening labs should be designed to be as fool proof as possible. All electrical connections should be concealed and protected and servicing should be made as easy as possible. Where teacher monitoring systems are provided the utmost flexibility should be requested. Dial access installations or other music listening stations should provide high quality earphones. Music listening may require better earphones than language teachers may desire but a schedule that makes it possible for both departments to use the same basic equipment may also make it feasible to secure fine headsets at less cost than two separate systems.

CHAPTER VII

Equipment

A MUSIC DEPARTMENT which is poorly equipped, even though excellently housed, cannot be expected to make progress at the desired rate. All good workmen are judged by the tools with which they work. If adequate equipment of good quality is supplied to a competent music teacher, success is assured in almost every situation. In far too many schools, definitely able directors are seriously handicapped by the lack of proper equipment. An important maxim in purchasing any school equipment is *buy something good and then take care of it*. This chapter presents some guidelines for the purchasing of school music equipment.

INSTRUMENTS

Pianos.—Upright pianos may be used in music rooms, but for major musical activities a grand piano should be available if possible. It is always advisable to purchase the largest size piano possible for the location and budget. Tone quality is dependent upon a large soundboard area and the string length for the lower tones. The keyboard height and pedal height should be standardized as in the large grand pianos.

Many manufacturers are attempting to incorporate plastics into the manufacture of pianos. Plastic key covering has proven to be satisfactory and perhaps even superior to ivory. Plastic action parts, and particularly plastic bushings, have not proven to be satisfactory. For school pianos, good wooden action parts and felt bushings still give the best service.

Upright pianos should be mounted on large, wide rubber casters, ball bearing style, or on metal frames equipped with this type of roller casters. Grand pianos should be mounted on a special frame equipped with all ball bearing rubber casters, so constructed that the instrument is not raised so much that operation of the pedals is made difficult. Such equipment facilitates movement and pays dividends in helping to keep the piano in tune and in preventing damage to the piano legs and floor.

It is not advisable to purchase cheap pianos. The extent of their daily use and relatively long periods of service are primary considerations. A cheap piano cannot produce a desirable quality of tone, often does not hold its tuning, and is not dependable mechanically. All of these considerations are essential for practical reasons as well as musical results.

Each school can, with the aid of its staff and available consultants, make its own specifications for pianos when putting out requests for bids. In preparing such specifications consideration should be given to the following items: overall size, cabinet and finish, casters, key bed, keys, plate, back and pin plank, tuning pins, sounding board, ribs, bridges, action, and musical tone. In addition, special conditions and factors may indicate the need for keyboard cover locks, special sized racks, dust covers, or other items.

All pianos should be tuned to American Standard Pitch, A-440, three or four times a year. It is unfair to ask students to listen to a piano that is badly out of time, or to ask them to perform with a piano when any appreciable adjustment of tuning level is required.

Electronic Pianos.—Electronic pianos are finding increasing favor with schools and colleges for class piano instructions and for theory classes. An electronic system makes it possible for the class to play together or individually and for the teacher to give attention to individuals, the whole class, or selected groups within the class. Tape and phonograph recordings can also be played through the system. The expense of the system and six electronic pianos is less than the cost of a grand piano.

Band and Orchestra Instruments.—Certain musical instruments which are necessary for every band and/or orchestra should be provided by the school, inasmuch as they are useful only in the band or orchestra (not especially suitable for solo playing), are expensive, and are often heavy and cumbersome to transport. Parents often cannot be induced to purchase such instruments for their children when the most desirable solo instruments are better known, less expensive, and easier to carry. Following is a list of these instruments: string basses, tubas, timpani, bassoons, harp, celesta, English horn, alto clarinets, bass clarinets, contrabass clarinets, bass drums, baritone saxophones, bass saxophone, chimes, vibraphone, xylophone, marimba, contrabassoon, concert snare drums, field snare drums, flugel horns, and percussion traps. In addition, some schools may also own D trumpets, French horns, euphoniums, violoncellos, violas, euphoniums, and bass trombones.

In some school systems where excellent bands and orchestras have been developed, systems have been worked out in which the schools own some or all of the

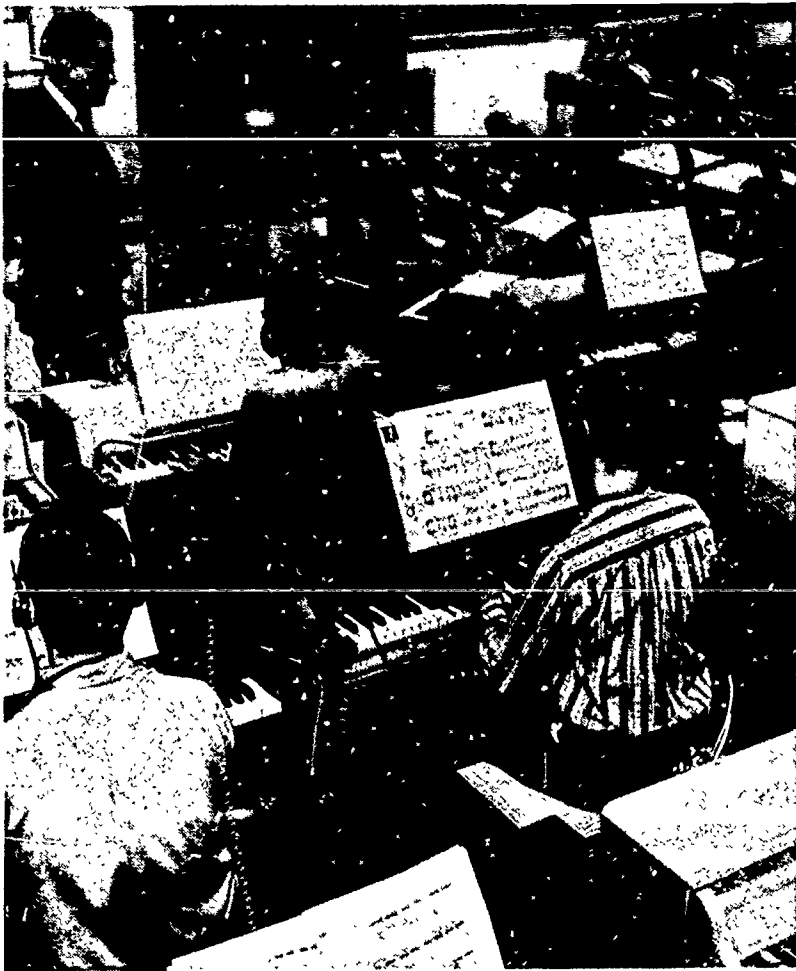

Systems of electronic pianos are finding increasing favor for class piano instruction and for theory classes.
Allentown (Pennsylvania) Senior High School

various band and orchestra instruments. These instruments are loaned or rented to the students for trial periods, in order to get large numbers of students started on musical instruments. This plan is often started in the elementary schools and carried over into the junior and senior high schools. Because there are certain problems in scheduling many different kinds of instruments, and because the basis for the instrumentation depends mainly on the violin, cornet, and clarinet, these instruments should be supplied in numbers and put in the elementary schools. Many school systems furnish the following instruments in the elementary schools:

Violins. Quarter, half, and full size.

Violas. For the larger students, some schools use full-size violins strung as violas in order to teach the alto clef.

Violoncellos. Quarter, half, and full size.

String basses. Quarter, half, and full size.

Oboes. With simplified systems of fingering.

B-flat clarinets.

French horns. Double, single, and possibly mellophones.

Cornets.

Trombones.

Baritones.

Tubas. Small upright E-flat tubas.

Full percussion equipment.

AUDIOVISUAL EQUIPMENT

"Between 1961 and 1964, amounts of audiovisual equipment in use in school systems increased phenomenally: overhead projectors, 17.5 percent; TV receivers, 123.1 percent; language laboratories, 112.1 percent; tape recorders, 54.9 percent; opaque projectors, 33.1 percent; radios, 33.0 percent; slide-filmstrip projectors, 28.3 percent; and 16mm projectors, 26.7 percent.¹

Recording and Reproducing Systems.—Development of sound recording and reproducing in the last decade has led artists to rely more and more heavily on their use. Equipment is now manufactured with quality which approaches the actual sounds recorded. The availability of such equipment was bound to result in new methods of teaching and learning music. Although this is a relatively new field and not used extensively, it has tremendous potential.

The use of recording equipment has made music learning more efficient and the results more satisfying. The student may record his own playing, listen to that of a professional, or have a permanent record made of a reading session of his original manuscript. Lessons in theory, harmony, music history, and other areas can be pre-recorded and used at the student's convenience and repeated as often as desired. Recordings of performances may be used in many ways to improve interpretation, tone quality, balance, and technique. Imaginative use of recording facilities may yield most varied and rewarding results.

While numerous systems are available to reproduce and record sound, the majority are not of sufficient quality to satisfy the needs of the music student. Quality is of utmost importance since poor equipment will defeat the purpose for which it is used. *Only equipment of professional quality should be considered by schools since theirs is a professional use in every sense of the word.*

The equipment discussed in this section is representative of the professional equipment available on the market today. Innovation is carrying specifications farther and farther toward perfection. Because of this fact, the specifications presented should be considered as minimum, for future equipment will undoubtedly be even better.

Magnetic tape.—A tape system consists of two components: the magnetic tape, and its transport and the associated electronics. Both are fundamental parts of such a system and a compromise on either will produce inferior results from the combination.

¹"Facts on American Education," *NEA Research Bulletin*, 44 (May 1966), 39.

The most practical way to buy the magnetic tape itself is to consider prices. Since an institution is generally able to buy on the wholesale level, the prices quoted on lots of tape are generally indicative of quality. Sales representatives will explain the various kinds of tapes and their uses to the buyer. In determining what the needs are for tape, an institution must determine first what the ultimate use for the tape will be and second how much uninterrupted playing time is needed.

Ultimate use of a tape will generally determine what tape quality is needed. Recordings destined for use to make phonograph records should be made on low noise, low print-through tape. Storage characteristics and uninterrupted playing time are least important in this application. However, if the recording is one to be used only for study purposes, a good general purpose tape is of sufficient quality. Storage may be anticipated, so good storage characteristics are necessary. Uninterrupted playing time must also be considered for convenience. Table 2 lists types of tape and their characteristics and is keyed to the appropriate uses. The use of extra-thin tapes (.65 mil or .5 mil) is not recommended except under emergency conditions. These tapes are poor for storage as well as difficult to handle.

Tape Recorders.—A wide range of so-called "professional" tape recorders is available. Unfortunately, the word "professional" has been misused as extensively as the term "hi-fi." The prospective buyer should be wary of misleading representation. A general set of specifications is included below to assist the buyer, although these can be used only as a rough guide. It can be generalized,

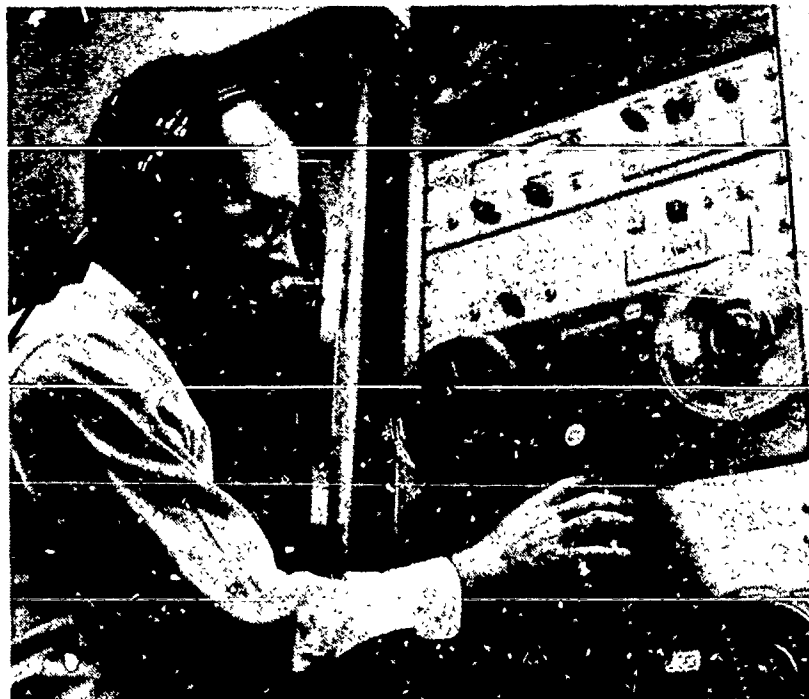

Only equipment of professional quality should be considered by schools.

however, that professional recorders are not available at present for less than \$600 (net price).

The value of tape systems is limited only by the imagination and operating skill. As suggested by the section on magnetic tape, they are applicable to all functions associated with music. Program versatility is very great since tapes may be cut and spliced with no limit except good judgment and taste.

Tape recorders have great practicality in that they are easy to operate, portable, and easily stored. Sensible use makes maintenance costs minimal. It should be empha-

TABLE 2
RELATION OF USE AND CHARACTERISTICS OF MAGNETIC TAPES

	Acetate Base	Mylar Base	Low Noise	Low Print- through	Long Playing Time (Thin Base)	Short Playing Time (Thick Base)	Long Playing Time (10" reels)	Short Playing Time (7" reels or less)	
Student Recorded Practice Tape	X	X			X			X	Ampex 511, 531, 541 Scotch 111, 102, 150
Reading Session		X			X		X		Ampex 631, 641 Scotch 202, 203
Performance— small number of copies (to be kept indefinitely)		X	X	X		X	X		Ampex 631, 641 Scotch 202, 203
Performance or Recording Session for wide distribu- tion on records or tap copies	X		X	X		X	X		Ampex 611, 411 Scotch 201

sized, however, that preventive maintenance should be exercised at the manufacturer's recommended intervals to maintain the high standards of quality incorporated in professional machines.

Professional recorders with these or better specifications are recommended for use by musicians:

Tape speed: 7½ ips minimum, 15 ips, 30 ips
Reel size: 7" 10", or 14"
Frequency response: ± 2 db 40-10,000 cps
Signal-to-noise ratio: 55 db
Flutter and Wow: 0.17%

It might be mentioned that the specifications most frequently avoided by pseudo-professional recorder manufacturers are signal-to-noise ratio and flutter and wow. These are just as important as any of the rest, but are hardest to maintain in poorly engineered machines.

Since both monaural and stereo recorders are available, the choice is left to the user. Stereo systems provide greater fidelity and versatility. In making fine tapes from which multiple copies will be made, four track stereo systems should be avoided, but otherwise they are quite acceptable.

Recorded tapes serve as the basis for many of the new types of learning laboratories which offer exciting possibilities for music education. Programmed materials which make possible self instruction in ear training are being made available on tapes. Student practice may be monitored by tapes for evaluation at a later time by the instructor. Though not many such electronic instruc-

tional systems are yet in use, the potential for music teaching is such that they should be investigated by any forward-looking building committee.

Recording Systems.—A local recording system should be available for use by students or faculty for the purpose of making their own tapes. The equipment should be as simple and rugged as possible.

A multi-channel recording system is used to make the best quality recordings possible. Two concepts are currently being employed in this area (see Figure 13). The first (Setup A) employs separate miking of each section or instrument, the mixing to take place in the studio by some qualified personnel. The second (Setup B) is allowing natural acoustical mixing in the recording room and making simply for a balanced sound. The second of these concepts is the simplest and usually most satisfactory for nonprofessional use. It requires less equipment and yields better results in most cases.

Record Players.—Phonograph records have advantages over tapes for certain educational uses. Stereo records are available at a cost significantly below that of pre-recorded tapes and with a negligible decrease in quality. Records are more easily handled for class use, since the instructor can skip around more easily than with tape.

Records are disadvantageous from the standpoint of wear and distortion. A heavily used record will deteriorate in quality though properly cared for. Many phonograph records manufactured are of inferior quality, even though they may be produced by large companies.

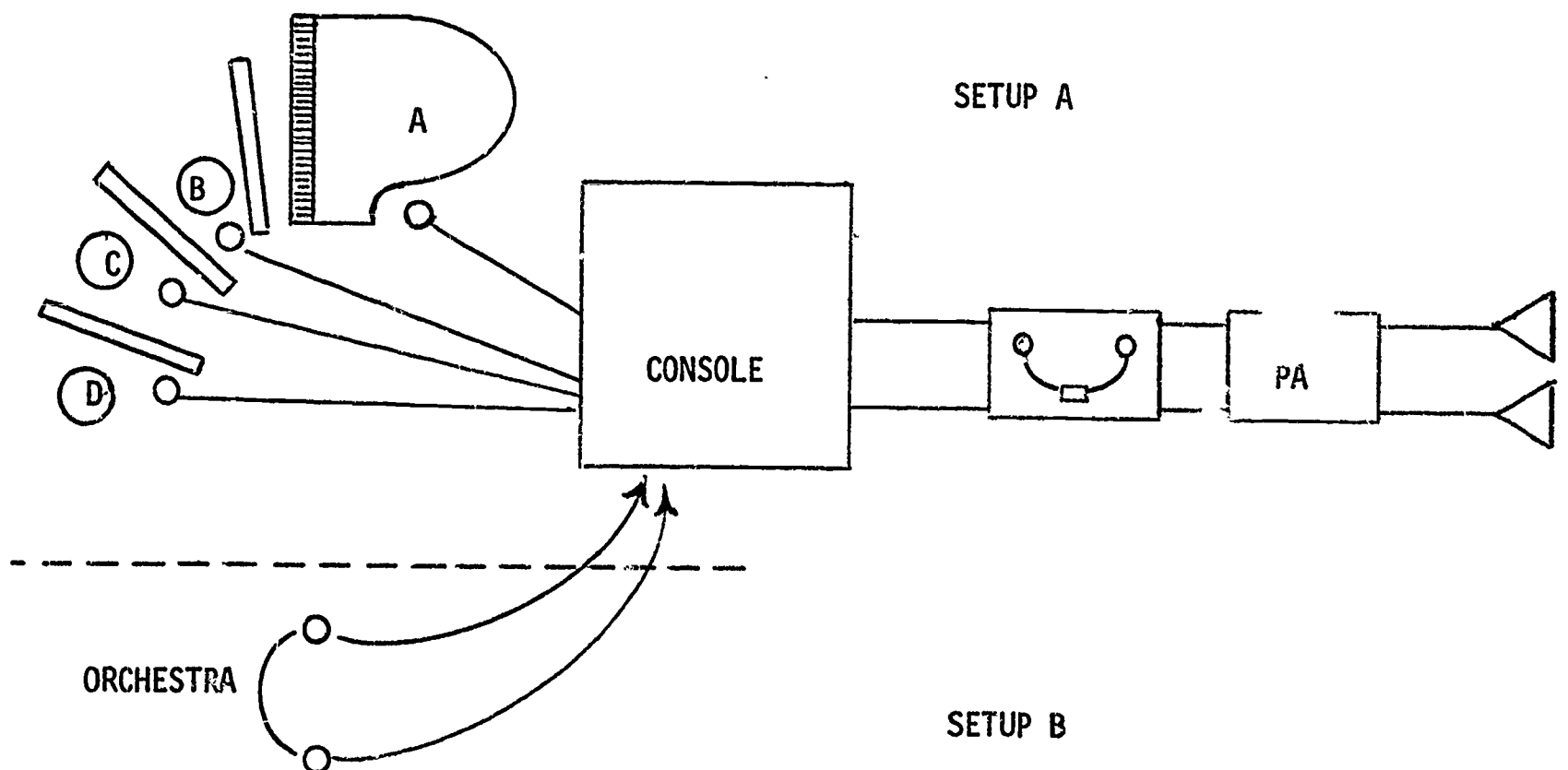
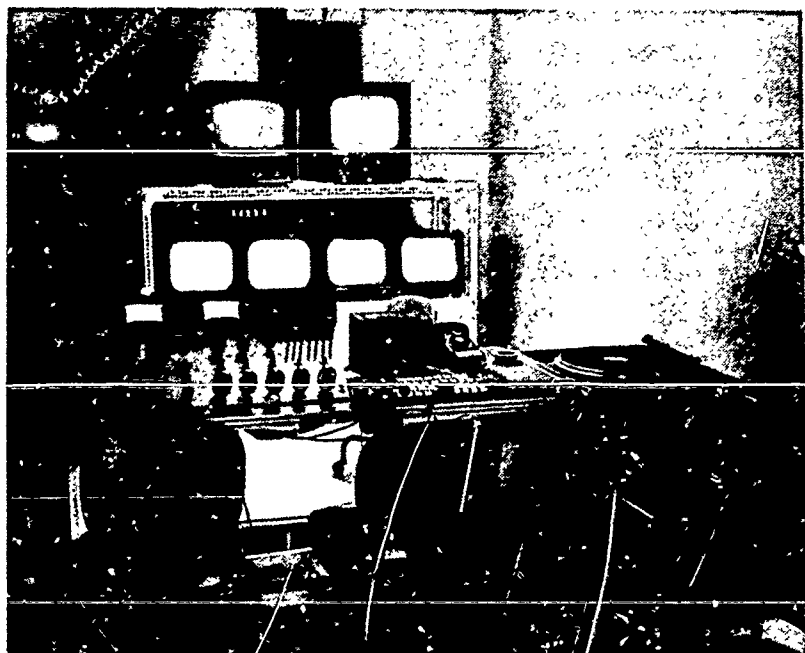

Figure 13.



A properly equipped control booth can serve both music education and communications education.
Tawes Fine Arts Center, University of Maryland

Two basic types of record players are available, the turntable and the record changer. Generally, better reproduction is available from the simpler turntable assembly, and the instructor can locate a specific spot on a recording more quickly. Record changers, however, have some advantages and often, lower cost. The best criterion for choice between the two types is possibly convenience.

The choice of a diamond or sapphire stylus is available. A diamond stylus will easily outlast the sapphire, but is much more expensive to replace. The sapphire stylus is generally considered more practical if students are using the record player, since one cannot assume the adequate care necessary to protect the substantial investment in a diamond one.

Radio.—In the last 1950's, a large number of high-fidelity radio stations went on the air, many featuring primarily serious music programming. Therefore, radio can be a valuable source of program material if an FM station is located in the vicinity. Recently, many FM stations have been licensed to employ FM multiplex for stereophonic broadcast. This system has worked satisfactorily in most cases, and should definitely be considered when designing a system. Larger systems using separate power amplifiers for a tape recorder or record player can be fitted most satisfactorily with a tuner. This type of radio does not include an amplifier for driving speakers, but is compatible with the power amplifier speaker systems. Tuners are generally less expensive than the radio-amplifier combinations, and generally of better quality.

When a system is being designed on a smaller scale, a power amplifier with a tuner built in can act as the

center for the system, the same amplifier being used for a record player and/or tape recorder. This makes for a complete and versatile space-saving system at minimum expense.

The desirability for a broadcast control booth is discussed in Chapter IV. This equipment may be used for broadcasting to the school system or the community by arrangement with local stations. Its value for music education and cultural enrichment is considerable but the opportunity it provides pupils with the experience in the growing field of communications should not be overlooked.

Power Amplifiers.—Larger systems designed to feed auditoriums or several rooms at once with a number of available program sources will require the use of a separate amplifier. This is a necessity because of the greater power needed and the heat generated by such amplifiers. Large auditoriums will usually be fitted with an amplifier of from 40 to 150 watts depending on their size. See the sections on acoustics, p. 75 for some recommendations for such installations.

Multiple-room feed systems will require a larger amplifier to drive the several loud-speakers being used. This type of design is rather disadvantageous, since driving a loudspeaker at a remote point requires a relatively heavy wire and at best is somewhat inefficient.

For the single room, high quality reproducing system, the power amplifier should be chosen for frequency response and power output. Only amplifiers with a very flat, wide frequency response should be considered. Although the full power potential of these amplifiers will never be used, they work best over an extended period of time when their full potential power is not being used.

Specifications for a typical, high-quality power amplifier suitable for feeding a set of stereo speakers might look like these:

Power input: 35 watts, 70 watts peak

Outputs: 4, 8, 16, 50 ohms

Input sensitivity: 1.3 volts into 250K

Frequency response: ± 0.1 db 20-20,000 cps
 ± 1 db 15-40,000 cps

Distortions Total harmonic distortion @ 35 watts: 0.5% 20-20,000 cps

Intermodulation distortion @ 35 watts: 0.5% 60-12,000 cps

Signal to noise ratio (hum): 90 db down at 35 watts

The specifications are similar to those of amplifiers manufactured by Marantz and McIntosh.

Playback Systems.—The arrangement of the components of playback systems is directly related to how they are to be used and of utmost importance to the satisfaction to be derived from them.

Auditorium system--speech or music

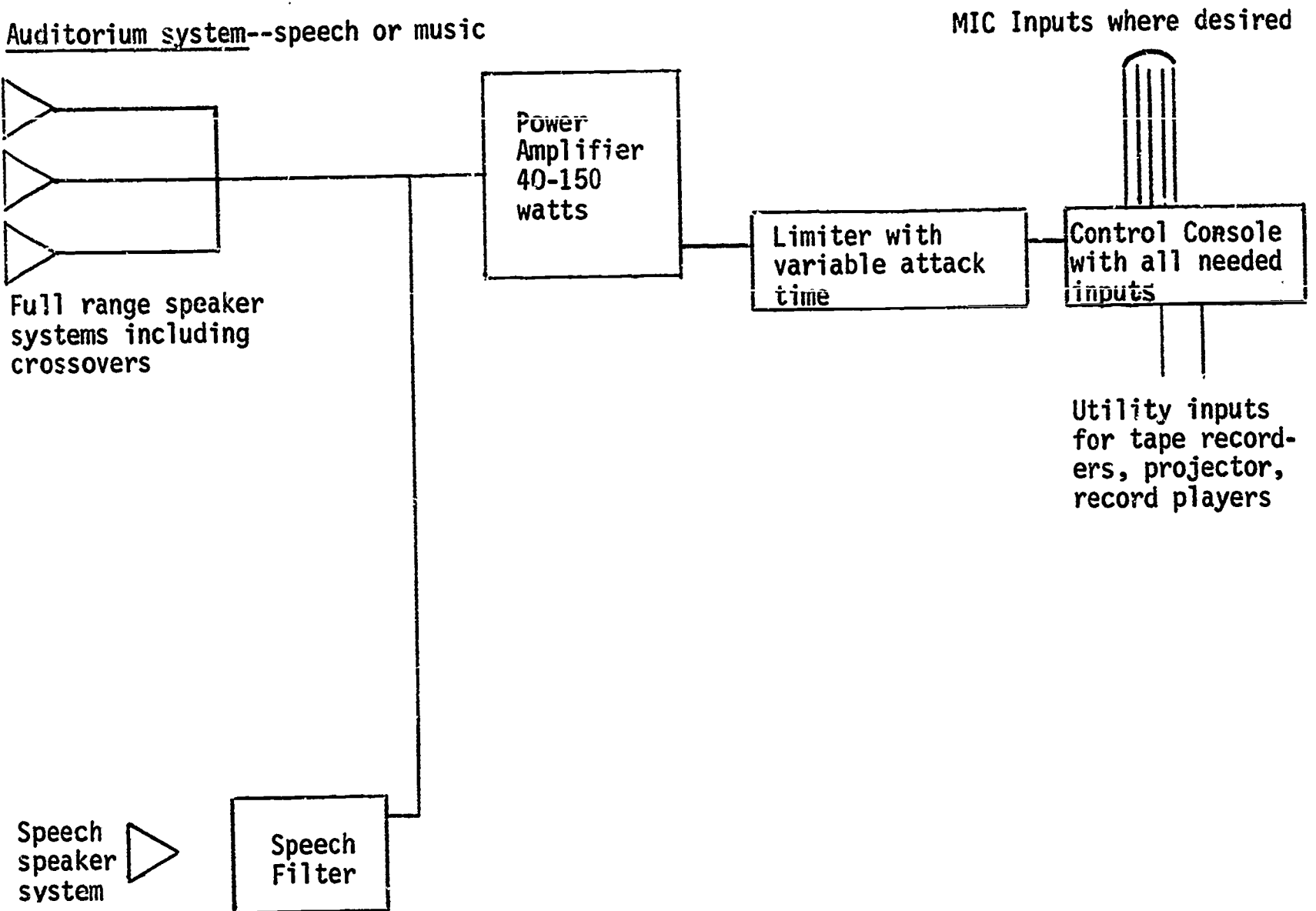

Figure 14.

For an auditorium, a playback system (Figure 14) should provide as many full range speakers as needed to cover the entire seating area and a speech speaker system that reproduces only the frequency range of the voice (i.e. 300-500 cps). This will minimize the feedback potential of the system and such a system, if not used at excessive volume, will sound more natural to the audience.

The power amplifier should have power appropriate to the size of the auditorium. A 40-watt amplifier might be used in a smaller auditorium whereas 150 watts might be needed in a larger auditorium. A limiter amplifier preceding the power amplifier is provided so that a variety of program types can be handled.

A control console should be matched to the needs of the user. Maximum versatility can be had with a multi-input mixing console which can mix several microphones simultaneously, each at its own level. Utility inputs should be included for they may be needed for playback of a tape or for motion picture projections.

A second type of playback equipment is that designed for use in a single system (Figure 15) and is the most

versatile of the systems discussed here. Providing for local input is of utmost importance. The speakers should be matched and of sufficient size to permit full volume. The amplifier should again be sufficient to reproduce sound even louder than usually needed. Here, in the one room system, is where power reserve is most important. Tape recorders, a tuner, or record player can all be portable or located in the same cabinet with the amplifier. They should be carefully matched to the amplifier in specifications in input impedance. Switching between them can be accomplished by plugs or switches.

Schools with listening laboratories will find the multi-input, multi-output system (Figure 16) the most inexpensive way of getting good quality reproduction of several programs in several locations simultaneously, with only one operator. A certain degree of convenience is sacrificed, and this should be seriously considered in design. The use of both tapes and records should be available so that the greatest versatility in programming can be possible. Each speaker system-earphone station can be fed with any combination of amplifier and input device. This is desirable to avoid interruption of program

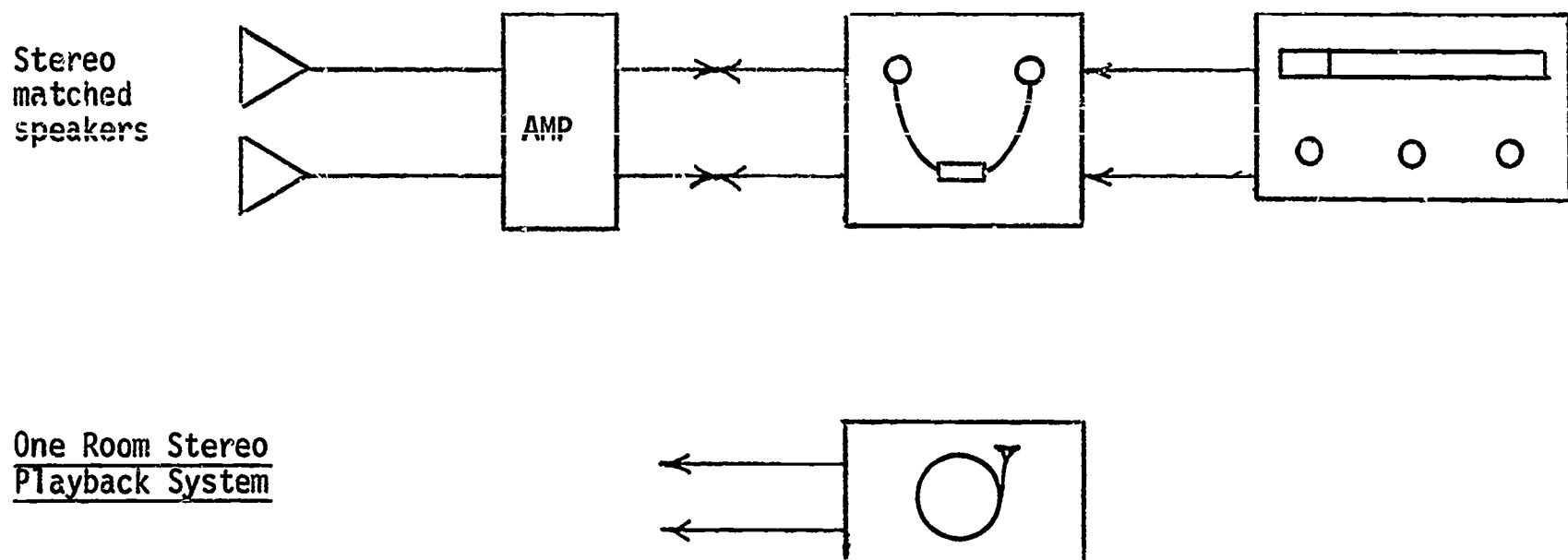

One Room Stereo Playback System

Figure 15.

if there is an equipment failure. Earphones for music listening should be of good quality.

Television.—The decision to incorporate provision for television in a school will probably not be made on the needs of the music department alone. Nevertheless, there are certain uses of this new teaching tool which music educators should consider in planning for the future. Music departments may be making increasing use of closed circuit television to provide general education experiences in music for the whole student body. Conduits from the stage to selected stations in the

school will provide for closed circuit use. The auditorium should also be equipped so that large groups can view programs originating elsewhere. Television monitoring systems may have a place in some practice room installations. Some informal instrumental instruction is currently being given over educational television and schools may want to provide the means of receiving these lessons in the music department where they can be followed up by the instructor. The portable television tape recorder, though relatively new and expensive, is a potential tool of great value to music educators.

Multi-channel, multi-input playback system

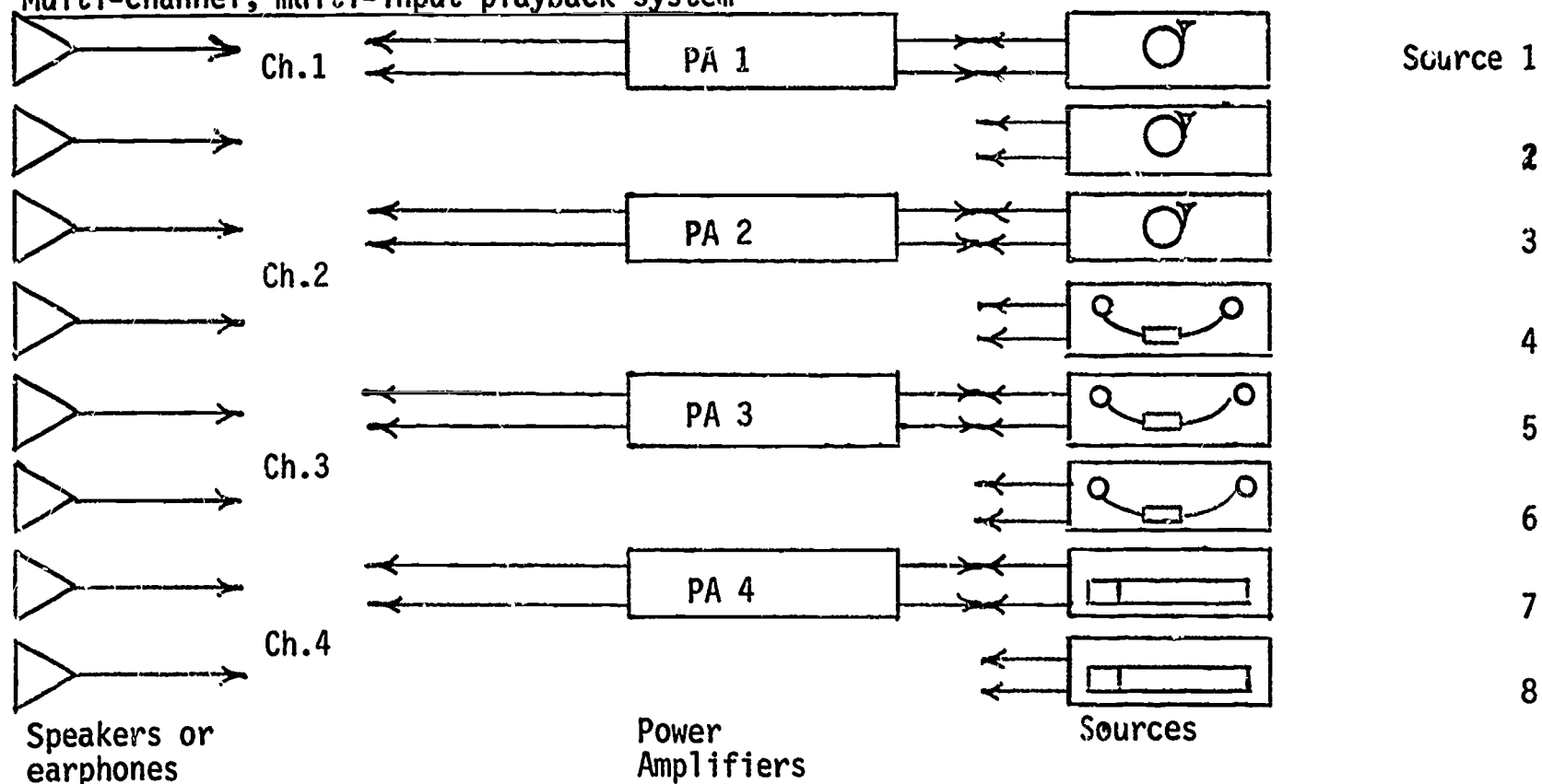

Figure 16.

Tuning Devices.—The standard minimum tuning equipment for instrumental music rooms is a well-constructed tuning bar with resonator, tuned to A 440 cycles per second for orchestra and Bb 446.2 for band. Several more elaborate electronic devices are also available. These can be obtained with several available amplified tones in appropriate combinations for bands (A, Bb), or orchestras (G, D, A and E). A distinct advantage to electronic tuners, in addition to the fact that the tones can be adjusted, is their ability to produce the tone continuously for any desired period. Transistorized models now available need no time for warm up.

A chromatic stroboscope has been manufactured for school use and found useful in teaching intonation. A visual indication of the pitch of a tone is given and the student can see when he is in tune. The device has other uses in the music and physics departments. A smaller device that gives only the standard Bb is also available.

Other instruments have been designed to train students in judging intonation. Some provide the means of reproducing all twelve tones of the chromatic scale in one or more octaves and enabling the operator to adjust the various tones to correspond with just or tempered tuning.

Metronomes.—In addition to spring-driven pendulum-type metronomes there are several electric metronomes now on the market that should be of great help to music teachers. Different pulsations are easily and accurately obtained by simple adjustment of a knobbed dial. Some electric metronomes are available which give, in addition to the aural indication, a visual indication by means of a small beam of light. In conditions of large volume of sound (such as drum practice) this visual indication is of considerable value. There are metronomes that will produce multiple beat patterns simultaneously. Some of the electronic tuners described above also contain electric metronomes.

Projectors.—It is assumed that each music department will have available, usually through the school audiovisual department, the conventional movie and still-picture projection equipment. The types deserve special mention, however, as their particular adaptability to music classes may be overlooked.

Whether a part of the equipment of the music department, or made available through the audiovisual department, a good 16mm sound projector is essential. Many excellent music films are available.² Music educators

will want to see that good speakers are provided with the equipment. Some projectors can be secured with additional speakers for use in large rooms and should be considered if such a need exists. The magnetic recording projector, which makes it possible to place sound on films, may have some usefulness for music departments.

Projectors for 2" x 2" slides and for filmstrips are available separately and in combination. For school purposes the combination units are probably the most desirable. Music departments will want to have access to such equipment because of the instructional filmstrips which are available. The old lantern slide projector (3¼" x 4") is still available and in more modern design. The ease with which slide materials may be prepared for this device is one reason to consider its purchase.

The advantages of the overhead projector have made it a widely used piece of equipment in recent years and there are enough applications to music teaching to make it a desirable piece of equipment. The use of overlays for the different voice parts of a choral composition may prove an effective means of studying polyphony. A similar technique might be used to analyze a symphonic composition to show the role of accompanying instruments on one transparency, main theme on another, and countermelody on still another overlay. The overhead projector can serve as an "electronic chalkboard" or which the instructor can write for viewing by large classes. With special equipment transparencies can be made by the photocopy process. This has obvious applications to the study of the conductor's score by large performing groups or other music classes.

Opaque projectors, though much improved, still require a darkened room. Nevertheless, they do have their value, and improved models can now project a sheet of music up to 8½" x 11".

Tachistoscopes are sometimes used by music departments to improve reading speed. Shutter control types that fit still projectors are manufactured. Other types control the light electronically or provide for movement of the film.

Screens.—Certain rooms in the music suite should be provided with wall or ceiling mounted screens. Portable screens should be available for other locations. The size and shape of the screens will be determined by the room size and audience capacity, as well as by the type of projector to be employed. In planning the location of the screen, it should be remembered that the beam of light should strike the screen at a 90-degree angle in order to avoid distortion. Enough space must be allowed at the front of the room so that no pupil is required to sit closer to the screen than twice its width. The pro-

² *Film Guide for Music Educators.* Edited by Donald J. Shelter. Washington, D. C.: Music Educators National Conference, 1961.

scenium arch in the auditorium should be high enough to accommodate a screen whose width is approximately one-sixth the depth of the audience area. Controls for raising and lowering auditorium screens should be provided in the projection area as well as backstage.

Mimeoscope.—The mimeoscope is an illuminated drawing board for tracing stencils from a formation drawing. Copies of the band formations can then be mimeographed and given to each member of the band, a valuable aid for the marching band director.

Central Sound Systems.—The equipment by which radio programs, phonograph recordings, and locally originated programs and announcements are distributed throughout the school is usually shared by the entire building and is therefore only partially the responsibility of the music department. Since, however, considerable use of such equipment is made by music teachers, it is important for them to be well informed in its selection and use.

A central sound system distributes, from a central location either in the school offices or audiovisual center, radio programs, phonograph recordings, tape recordings, or live programs originating from any of several locations where microphone outlets are provided. Most such systems are also equipped so that whatever is occurring in a classroom may be monitored from the central switchboard, and the equipment also can be used as a two-way communication system between the practice room or classroom and office. The system can also be used to provide public address amplification in school auditoriums and gymnasiums.

All equipment should be purchased from a well-established manufacturer and installed by engineers experienced in such work. Some of the points on which music teachers should check when such equipment is under consideration are listed below.

Microphone outlets should be provided in all large rehearsal rooms so that programs originating in the music department can be fed into the system.

Loudspeakers in the music department, auditorium, and other principal classrooms should be of sufficient size and quality to preserve the fidelity of music programs. This specification is especially important since the smaller and cheaper speakers which may be entirely satisfactory for spoken announcements are often inadequate for musical reproduction.

Microphones should be of high quality and adapted to the purpose for which they are to be used. For public address purposes cardioid microphones, with their comparative freedom from feedback, are standard.

Tape-recording input and output channels should be

provided. That is, it should be possible to take a tape recording off the air at any hour, and feed it back into the system at a more convenient time. Most of the better new systems have such a provision, and with the wide use of tape recordings at present it is a mistake to omit it for reasons of economy. Older installations can be easily adapted to the purpose.

Portable Public Address Systems.—As with the central sound systems, portable systems will usually be shared with other departments, but as such equipment may be used for occasions such as outdoor band concerts and musical performances in auditoriums not permanently equipped, the same supervision should be exercised in its selection as with the central system. Microphones should be of the cardioid type and of high quality. The amplifier should have sufficient reserve power to reproduce music without distortion. Amplifiers are rated in wattage of output, and a fifty-watt amplifier should be the minimum for outdoor use and large auditoriums. Loudspeakers are available in many types but many of them designed for spoken announcements are unsuitable for musical use. High quality speakers mounted in bass-reflex baffles are generally most satisfactory for musical purposes where extreme volume is unnecessary, and where difficult problems of microphone placement do not accentuate their tendency to feedback. In conditions involving these difficulties, horn-type speakers may be necessary, but they must be selected with great care, as many horn-type speakers have poor fidelity characteristics.

Of considerable use to the drilling of the marching band is the light, self-contained, battery-operated amplifier which may be carried by means of a shoulder strap and used for directions and announcements. It is of no use for musical amplification, but its extreme portability and ease of operation make it a valuable rehearsal aid.

Monitoring Systems.—Where a number of practice rooms are to be in use at one time it is desirable that the teacher be able to supervise the work of the practice rooms from his office. If high fidelity reproduction is necessary, this is best accomplished by an installation of a small central sound system similar to the large sound system described in a previous section. The switchboard can be installed in the director's office or other similar location. Since, however, most of such use will be in the nature of casual inspection, with the final polishing done by the teacher in the room, considerable cost can be saved, and simplification of operation achieved, by the installation of an inexpensive intercommunication system such as is used in business offices. Such a system is based on a unit consisting of a compact loudspeaker which can be reversed and used as a microphone by the

INCORRECT SCREEN ANGLES WHICH PRODUCE HORIZONTAL AND VERTICAL KEYSTONING

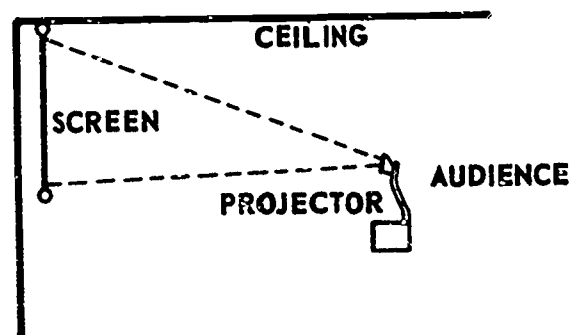
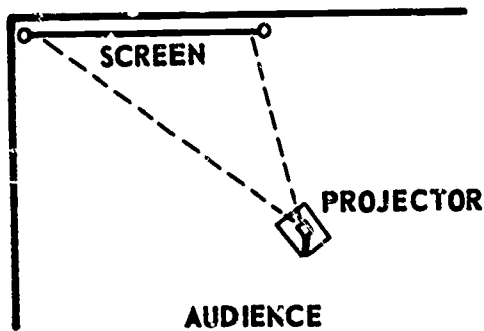
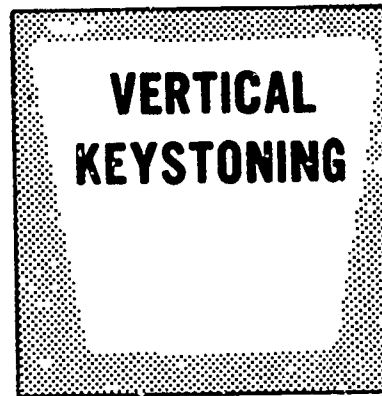
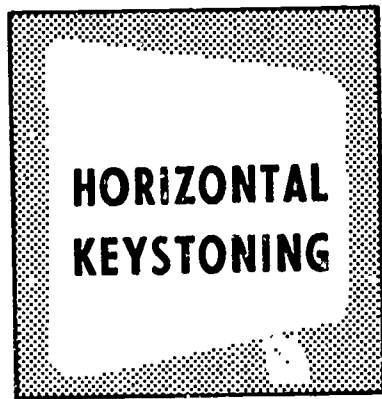

CORRECT SCREEN ANGLES WHICH PRODUCE A SQUARE LIGHT PATTERN ON THE SCREEN

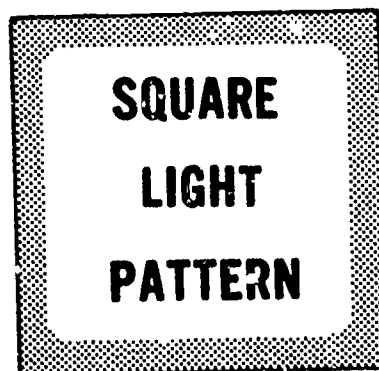
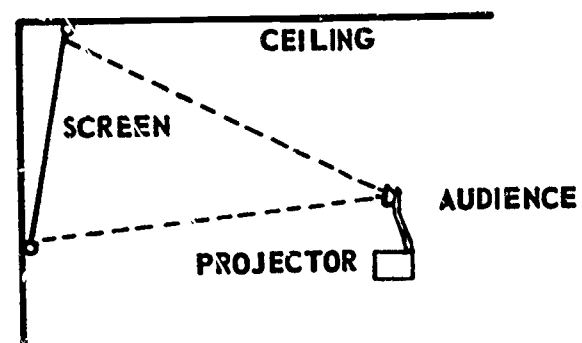
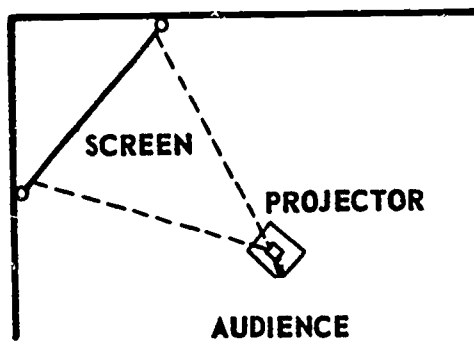

In planning the location of the screen, it should be remembered that the beam of light should strike the screen at a 90 degree angle in order to avoid distortion.

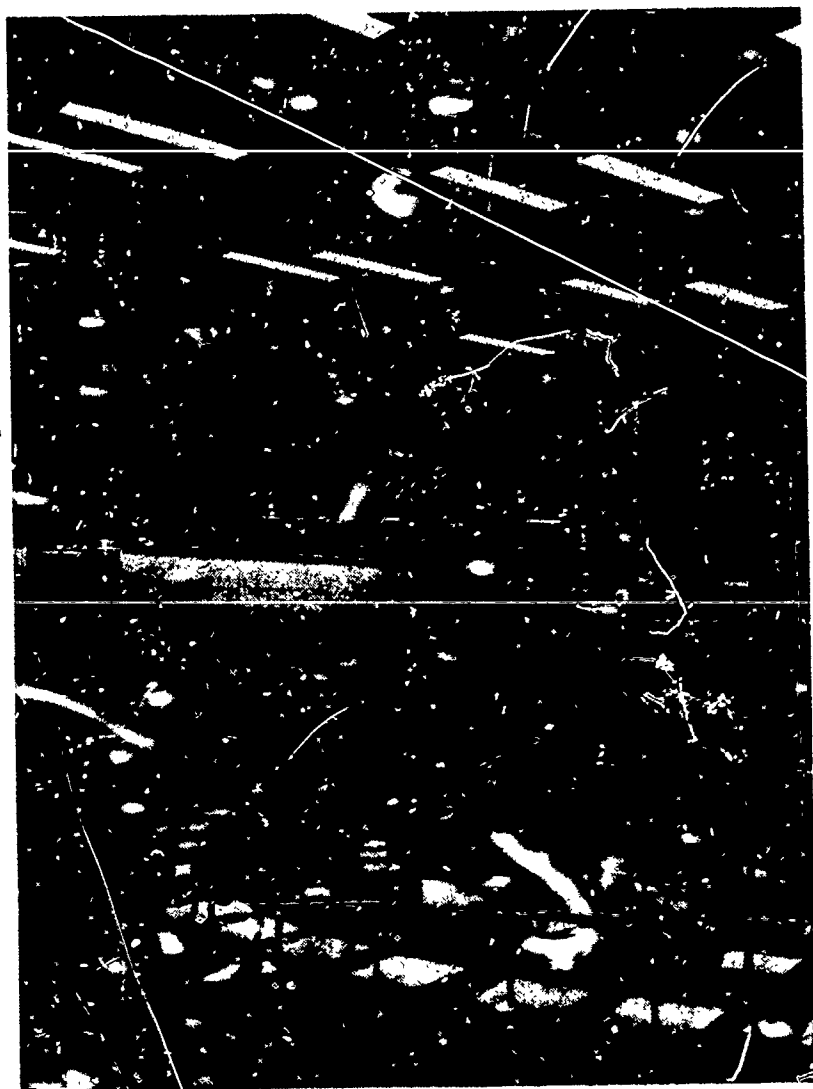

The telescopic metal stand has become standard equipment for school music departments. Chairs should be of a type to encourage students to sit erect.

Malabar High School

Mansfield, Ohio

Richards, Bauer & Moorhead, Architects

flick of a switch. A number of variations in application can be worked out by engineers supplying such equipment, but basically the system consists of master stations placed in directors' offices capable of calling or listening at will to any other station; and staff stations placed in the practice rooms, capable of communicating only with the master stations.

In the simplest of these systems, consisting of one master station, and one to ten staff stations, the staff stations cannot originate calls but can be heard only when the proper switches are actuated at the master station. It is possible, however, for equipment to be arranged so that the staff stations may originate calls to the master station. Experience indicates the latter feature is desirable, since students accustomed to the use of the equipment are likely to request assistance from the director if calling facilities are available. Where practice room facilities are shared by two or more teachers with separate offices it is possible to install a combination

of two or more master stations and any number of staff stations, or a system consisting entirely of master stations, at, of course, greater cost.

The fidelity of the intercommunication system of this type is not very high, but is sufficient for the average use to which it is put.

Other Electronic Equipment.—Numerous other devices have been invented and are being used by music educators for a variety of specialized tasks. Among them are: the audiometer, dynalevel, electronic blackboard, oscilloscope, and the spectrum analyzer.

FURNITURE

Music Stands.—It is recommended that schools purchase a high quality non-folding stand which is heavy and durable—a telescopic metal stand with a heavy, non-breakable base. In most cases it is safe to estimate fifty stands for an instrumental group of 75, or a ratio of 1:1½. Extra stands will be needed for the practice rooms. Students often provide their own (folding) music stands for special appearances when school stands are not easily transported.

Chairs.—High quality, *nonfolding* chairs are recommended for music seats. Comfort should be a major consideration but the chairs should encourage students to sit erect. Chairs for singers should provide support for the lower back.

Chair legs should have rubber tips or rounded metal plates to protect the floors. It is desirable to have a shelf under the chairs for books and music. String bass players should have wood or metal stools (approximately 30 in. high, such as are used in many factories). It would be

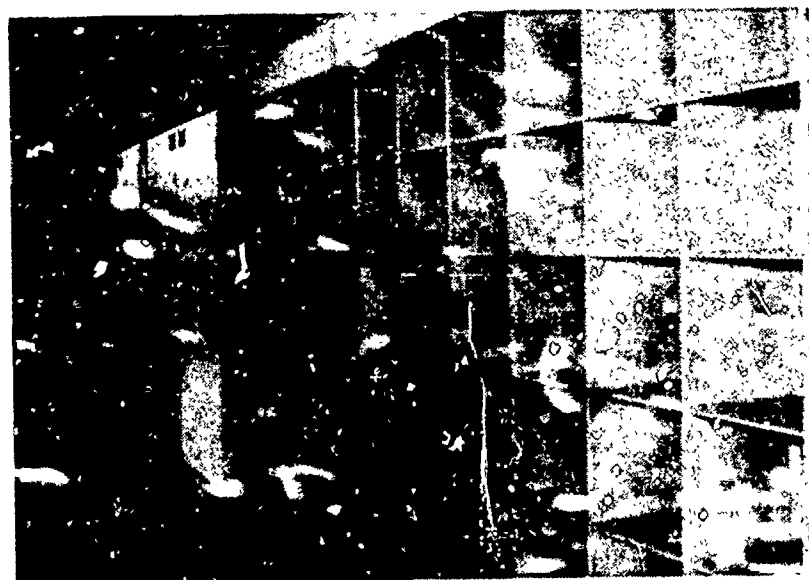

Forsythe Junior High School in Ann Arbor, Michigan, has built-in shelves (12 in. x 12 in. x 12 in.) between the door and the instrument storage cabinets so that students have a place to deposit books and other belongings.

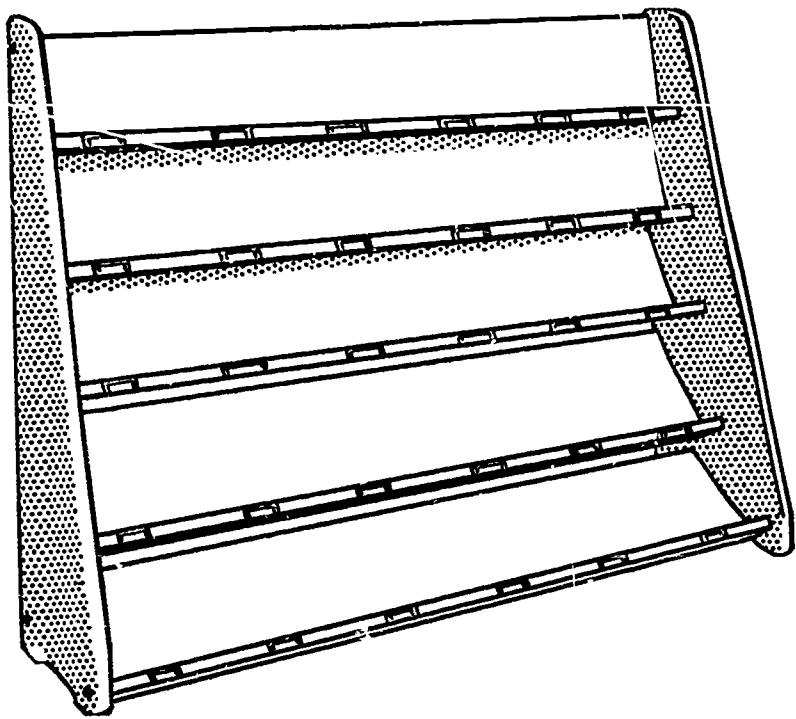

Even the smallest music department needs a sorting rack.

well to purchase a swivel stool (throne) with adjustable height for the timpanist. Cellists should have chairs which enable them to sit on the forward edge to play the instrument. These chairs should be somewhat higher than ordinary chairs—19 in. is the recommended height for most players. Special chairs with supports for sousaphones are available.

Conductor's Podium.—The podium should be movable and its construction should match the room or stage. The minimum size would be approximately 8 in. high and the top should be about 3 ft. square. A larger podium (14 in. high and 3 ft. square, with a 12 in. step fastened on each end) is more satisfactory for larger instrumental groups. In order to prevent slipping, the top should be covered with rubber sheeting. To avoid scratching the floor, metal gliders should be placed on the corners.

Bulletin and Chalk Boards.—The cork board for official notices should be near the music director's office. It should be built right into the wall, so as to be neat as well as secure. This bulletin board should be encased in glass with an inside light, and equipped with a door that can be locked. Another board can be reserved for posting general notices, information, advertisements, cartoons, and less official news. A good size for the bulletin board is 30 in. by 30 in.

Chalkboards, at least some of them permanent fixtures, should be provided in rehearsal areas. They can be used to list the rehearsal routine for the period, emphasize important announcements, and as a general teaching aid.

Portable chalkboards have many uses in a music department. One side should be slate, and the other side constructed as a cork bulletin board. Light green chalkboards are recommended. Some chalkboards should have staff lines on them. The lines should be approximately 1 in. apart and 3 or 4 in. between the staves. Some manufacturers will line the boards at the factory.

A recent development is an electronic board with staff lines which reproduce the correct pitch when touched with a pointer.

Sorting Rack.—Every music department should be equipped with a music sorting rack. Such a rack is convenient for distributing music to folders and for re-assembling the music when ready for storage again. A sorting rack should consist of four or five slanting shelves, 1 in. by 15 in. by 75 in. (or longer), with 1 in. by 2 in. strips at the bottom of each shelf to hold the music in place. The size of the largest folios used in schools is about 12 in. by 15 in. Each shelf of the sorting rack should be made to hold a desired number of these folders, allowing 2 in. between folios, or 14 in. per folio. Two or more racks placed against the corner walls of the music library, rehearsal room, or office make it possible to use the racks with a minimum of walking.

Sufficient shelf space should be provided for the greatest number of folios used by any one musical organization. This rack may be used equally well by both vocal and instrumental music organizations.

Percussion Cabinet.—Members of the percussion section of a band or orchestra play many different types of instruments, from real musical instruments such as bells, vibraphone, marimba, chimes, xylophone, to "gadgets" for sound effects such as triangle, sleigh bells, bird and train whistles, and numerous other special sounds. It is wise to have all of this small percussion equipment assembled in one place for safe storage as well as for accessibility.

The percussion cabinet should be equipped with rubber casters so that it can be moved easily around the

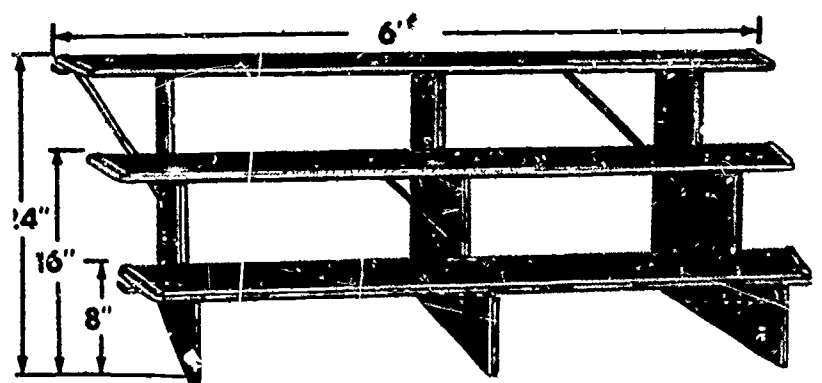

Portable choral risers are generally considered essential pieces of equipment for a music department.

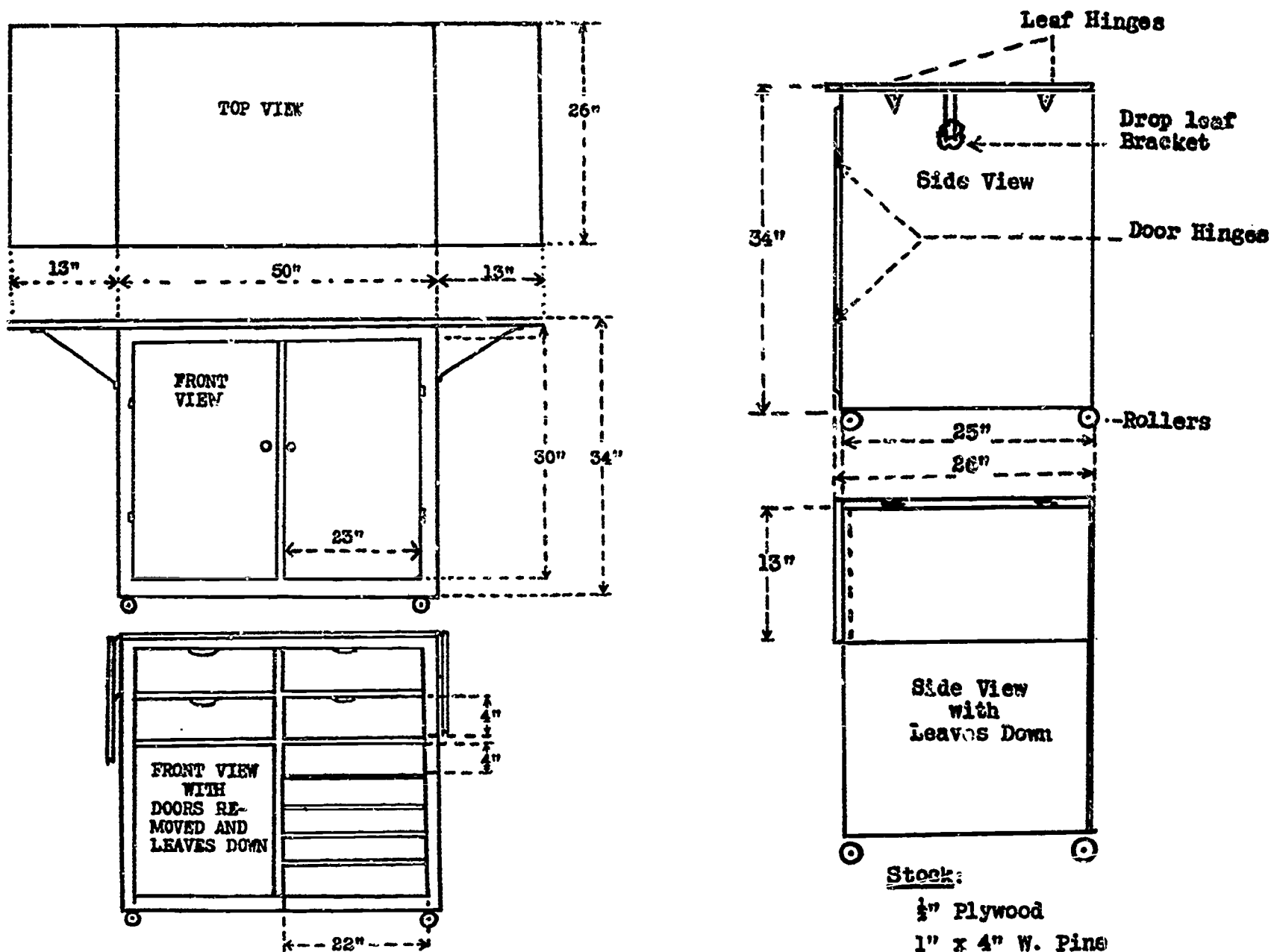

A percussion cabinet offers safe storage and accessibility for small instruments.

rehearsal room. It would be wise to have two of the casters with wheel locks to keep the stand from rolling while being used. It is also suggested that two handles be attached for lifting purposes. Drop-leaf extensions on either side of the cabinet top are useful. The shelves should be designed to hold various sizes of cymbals, tom-toms, and tambourines. One shelf should be long enough to hold a set of orchestra bells.

Risers.—Risers of various kinds are an important part of the equipment of any music department. Risers may be purchased from commercial dealers. Those available are: for standing chorus (two or more rows), seated chorus, and band or orchestra. The instrumental music risers can be purchased to fit almost any stage or music room. Portable and collapsible, they are constructed from plywood, a combination of metal and wood, and all metal.

Risers may also be built in the school industrial arts or carpentry shops. It is usually best to build them solidly and in boxlike, portable sections (not too heavy to handle easily), that fit together to form a semicircle. Each step of the standing chorus riser should be 14 to 16 in. from the front to the back, and the length and number of sections will depend on the size of the chorus and auditorium stage. Each succeeding step should be approximately 8 in. higher than the preceding one. The risers for a seated chorus should be similar to the ones for standing chorus, but should be from 32 to 40 in. wide from front to back, i.e. for each level of chairs. The number of elevations depends upon the number of students in the chorus as well as upon the size of the music room or stage.

Risers for the band or orchestra are similar to those for the seated chorus and for the average music room or



Choral shell constructed like a stage flat of $\frac{1}{2}$ in. battens and $\frac{1}{8}$ in plywood sheets by MENC member Gordon E. Tjernlund of Corvallis, Oregon.

stage there should be three or four elevations in addition to the floor level, with each elevation 6 to 8 in. higher than the preceding one, and each elevation at least four feet from front to back. The highest level should be the widest to accommodate the larger instruments including the percussion section. In building these sections care should be taken not to build the individual sections too large since the excessive weight would make it difficult to move them from place to place. Larger pieces are also more difficult to store. Specifications recommended by the Florida State Department of Education are shown in Table 3.

TABLE 3

DIMENSIONS OF INSTRUMENTAL RISERS

	<i>Preferred</i>	<i>Acceptable</i>
Row 5 (back)	6'	5'6" to 7'
Row 4	4'9"	4'6" to 5'6"
Row 3	4'9"	4'3" to 5'6"
Row 2	4'6"	4' to 5'
Row 1 (front)	floor	floor

Shells.—Portable acoustical shells are frequently necessary pieces of equipment for music departments. This is particularly true if the musical groups are expected to perform in an auditorium with a high stage house, a large field house, or out of doors. Shells not only reflect the sound to the audience but greatly improve the conditions for the performers themselves in such situations.



Dolly for moving a harp has been designed at the School of Music of Indiana University. Plan for the dolly on page 103 are provided by the School of Music of the University of Michigan.

The discussion of acoustics in Chapter VI dealt with the requirements of reflecting shells. Most important is the necessity for sufficient weight if the panels are to reflect low and middle frequencies adequately. The surface should be hard and panels need to be reasonably large in size. It is possible to meet such specifications and still maintain portability. Several commercial firms have developed a variety of shells for choral and instrumental groups including mobile units for outdoor concerts.

Miscellaneous.—Special situations will call for other types of equipment. Many grade school music teachers have had special boxes fitted with rubber wheels and handles to facilitate carrying songbooks, phonograph records, and other equipment to classrooms. Movable coat and hat racks may be useful in some situations. A flag and stand may be required where a rehearsal area is also to be used as a small auditorium. Picture screens are almost a necessity in most classrooms today and remind one of the desirability of providing curtains or blinds to darken the room.

HARP DOLLY

BLOCK 1" T. 2" H. 6" L. BIRCH -- RADIUS 2"
 ENDS & TOP. USE 2 1/4" TABLE BOLTS
 WITH WING NUTS & WASHERS FOR
 ADJUSTMENT.

WOOD -- 3/4" FIR PLYWOOD
 FINISH -- VARNISH
 CASTERS -- KILLIAN #32033BC OR EQUAL
 2 REQUIRED

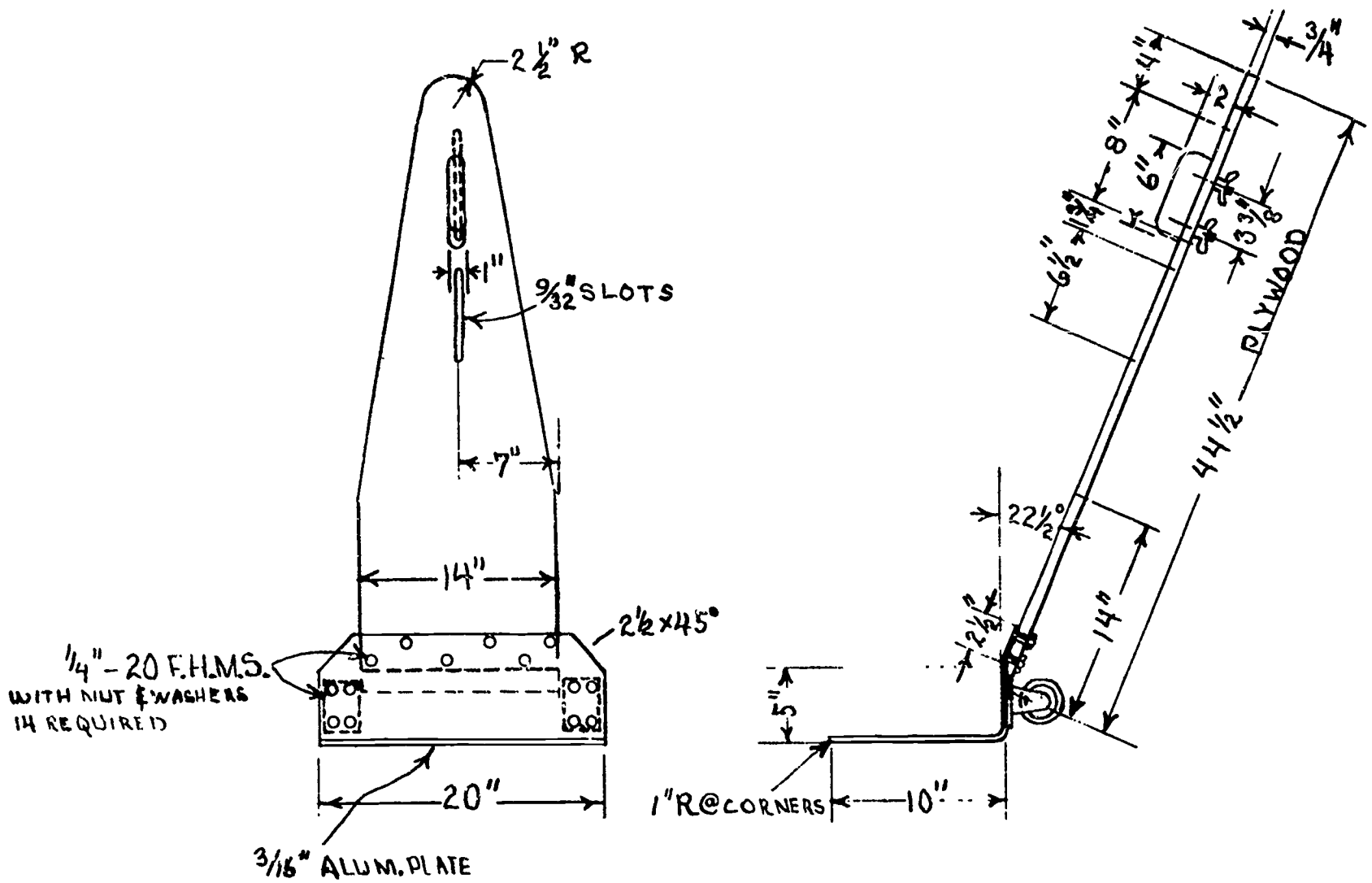

Case Study: Building a College Music Building

THIS STUDY describes the planning, design and construction of a typical music building in a typical California state college. It is based primarily on experience at San Fernando Valley State College. Four state college music buildings have been built in the last ten years at Long Beach, Los Angeles, Northridge, and Hayward. The basic specifications (B-2 Programs) for the last three were essentially the same, but the buildings differ widely in physical layout, appearances and special features. Comparisons have been introduced wherever they are meaningful.

The figures have been simplified and rounded off, so as to be typical rather than precise. Nevertheless, they give a good idea of the kind of estimates and assumptions necessary in planning music facilities. Auditoriums and concert halls are not discussed because they were not included in any of these music buildings.

DETERMINATION OF NEEDS

Classrooms.—The college was planned for a maximum enrollment of 20,000 full time equivalent (FTE) students. The music building was expected to house a complete music program (except for public performance) for a student body of that size.

A study of class enrollment figures from a large number of liberal arts colleges and universities indicated that music classes average three and one-half to four percent of the total enrollment. Three and three-quarter percent was taken as the probable maximum enrollment in music, and facilities were planned for 750 FTE students. Student stations required must be calculated from maximum enrollment figures. Actual class enrollments will never reach the maximum; there are always some classes not filled. For statistical purposes, classrooms are charged with 70 percent of the maximum number of student stations to arrive at probable working FTE. Thus the average FTE for this plant would be close to 525.

Between 1950 and 1965 Gerald Strang participated in the planning of four college music buildings; Long Beach City College, California State College at Long Beach, San Fernando Valley State College (Northridge), and California State College at Hayward. He was an acoustical consultant to the architects in the last two, and chairman of the music department at San Fernando Valley State College during construction and equipping of the building there. At the request of the Committee, he has done this case study of his experiences.

A full student load is considered to be 15 units. Thus maximum student units came to (15×750) 11,250.

The California state colleges recognize three types of classes: *Lecture* (1 hr. per unit per week); *Activity* (2 hr. per unit per week); *Laboratory* (3 hr. per unit per week). Music classes fall in all three categories. Assuming an average of 2 hours per unit, preparation had to be made for 22,500 student hours per week.

Utilization of classrooms varies widely. An extensive evening program is carried on; classes are scheduled from 8 A.M. to 10 P.M. For planning purposes, maximum average classroom utilization was estimated at 8 hours per day, 5 days per week, or 40 hours per week. On this basis, 22,500 student hours require 562.5 classroom hours. Average class size, for planning purposes, was estimated at 25. Thus our 562.5 classroom hours demand 22.5 classrooms.

Offices.—Taught in classes averaging 25, 11,250 student units constitute 450 teaching units. At a 12-unit full time teaching load, 37.5 full time teachers are required. Actually the state college teaching load formulas in California give extra load credit for activity and laboratory classes which meet more than one hour per unit. Allowing for load formulas, it was estimated that offices must be provided for 45 full time teachers.

Practice Rooms.—Not all of the students use practice rooms. History and appreciation classes for example rarely require their use. Some students will practice entirely at home. If 75 percent of the students practice one hour a day, five days per week $(.75 \times 750 \times 5)$ provision must be made for 2800 practice hours per week. If practice rooms are assigned the same plant utilization value as classrooms, (40 hrs. per week), $(2800/40)$ 70 practice rooms are required.

San Fernando Valley State College music building actually provided 23 classrooms and 70 practice rooms. Twenty-seven two-man offices were supplied, in addition to a department head's office and small offices for four coordinators. Four of the offices are sound-treated to double as teaching studios. Hayward increased the office-studios to 12 and decreased standard offices.

Auxiliary Areas.—Service and support facilities are not directly related to student ratios. We knew we would need extensive storage, work rooms and preparation rooms, a conference room, an organ studio, and a music-record library. We planned also extensive recording and

TABLE 4
 DISTRIBUTION OF MUSIC FACILITIES
 CALIFORNIA STATE COLLEGE AT HAYWARD

Page	Function	Type	STATIONS			FTE	Unit Area		Area Extended	
			No. of Rooms	Ea. Unit	Total		Reg.	Aux.	Reg.	Aux.
11	Music Education	Act.	4	32	128	90.88	960		3840	
12	Work-Storage Area		2					384		768
15	Teaching Studios	Lect.	12	1	12	18.00	216		2592	
18	Instrumental Instruction	Act.	3	12	36	25.56	672		2016	
19	Piano Instruction	Act.	2	10	20	14.20	864		1728	
21	Voice Instruction	Act.	3	15	45	31.95	720		2160	
24	Theory and Composition	Lect.	2	25	50	75.00	864		1728	
25	Control Room		1					100		100
26	Ear Training & Sight Singing Laboratory	Act.	1	25	25	17.75	864		864	
27	Music History & Apprec.	Act.	2	35	70	49.70	792		1584	
28	Music History, Apprec., and Integrated Arts	Lect.	1	90	90	135.00	1404		1404	
29	Storage		1					384		384
32	Seminar Rooms	Sem.	2	10	20		250		500	
33	Seminar Rooms	Sem.	2	15	30		350		700	
34	Band-Orchestra Rehearsal	Act.	1	150	150		3240		3240	
37	Inst. Storage & Repair		1					1120		1120
40	Instrumental Music Lib.		1					360		360
43	Robz and Uniform Storage		1					768		768
47	Dressing Rooms		2					240		480
48	Control Room		1					192		192
49	General Storage (risers)		1					1060		1060
50	Choral Rehearsal	Act.	1	200	200		2912		2912	
52	Choral Music Library		1					720		720
55	Control Room		1					192		192
56	Faculty Audition		4					192		768
58	Organ Studio		1					600		600
59	Practice Rooms, Small (48 @ 8' x 10')							3840		3840
61	Practice Rooms, Medium (12 @ 10' x 12')							1440		1440
63	Practice Rooms, Large (8 @ 16' x 16')							2048		2048
65	Student Locker Area								25,268	14,840
										40,108
<i>Offices:</i>										
66	Department Head									180
67	Secretarial and Reception									320
68	Workroom and Storage									400
69	Conference Room									550
71	Coordinators (4 rooms)									576
72	Clerical Area									400
73	Workroom and Storage									400
76	Faculty (for 45 persons)									4050
										<u>6,876</u>

Estimated FTE to be served, 458.

77 Auditorium—See Creative Arts Production Facilities

listening facilities. The nature and extent of these had to be empirically developed in the next stage.

FINANCING

The usual promotional effort, the jockeying of needs against available funds, the compromises and frustrations involved in negotiations for an appropriation, were not necessary at San Fernando. The limits originally set for Los Angeles State College were applied here and later to Hayward. A state bond issue provided funds for the first five buildings at Northridge. A sum of approximately \$2,250,000 was assigned to the music building. Two small theatres in the speech-drama building were to house concerts until an auditorium could be budgeted and built.

Approximately ten percent of the building costs were allocated to equipment, leaving about \$2,000,000 for construction purposes. The area to be planned was a function of costs. At \$25 per square foot, 80,000 sq. ft. could be built; at \$30, 66,000 sq. ft. The actual building contains about 78,000 sq. ft.

A good deal of the space in any building is devoted to halls, stairways, sanitary and maintenance facilities, and heating and ventilation. Assuming 65 percent assignable floor space, about 50,000 sq. ft. could be planned for music use.

DETAILED SPECIFICATIONS

The California state colleges develop the detailed descriptions of new facilities through a standard form, B-2 (see Figure 17). A collection of B-2's covering every aspect of the proposed building is called the B-2 Building Program. That developed at Los Angeles State College was the basis for those used at Northridge and Hayward.

The entire music faculty participates in preparing the B-2's. Visits to other plants, study of relevant literature, consultations with specialists, and the experience of the faculty help to shape the specifications. Endless meetings and countless hours of faculty effort are required. Even when an existing B-2 Program can be used as a basis, revisions, additions and improvements force a substantially complete redevelopment.

A separate description is provided for each type of room required. Size, function, special features, and equipment are described. Auxiliary areas are fully specified, and justified in relation to the program they serve.

Preliminary Breakdown.—The original analysis of needs suggested that about 23 classrooms, 70 practice rooms, and offices for about 50 teachers would be required.

To determine the kinds and sizes of rooms, a projection

of the curriculum had to be made, estimating probable offerings and student loads. For a new school, this is not much more than crystal-ball gazing. For an established school, the enrollment records would provide clear guidelines.

The distribution presented by California State College at Hayward is shown in Table 4. Each of the three colleges chose to emphasize some special programs. Los Angeles included a psychology of music laboratory. Northridge included an acoustics laboratory, and special equipment for recording and sound distribution centered in a master control room. Northridge and Hayward were permitted to include conduit for an eventual closed circuit TV installation, to be established later.

The practice has been to avoid the general purpose classroom. Each space is designed for a primary function. This does not prevent multiple use, but makes available optimum conditions for each aspect of the program. Though class piano, elementary music education, and counterpoint could be taught in the same room, all suffer from the compromise.

Room Sizes.—No rule of thumb could be used for room sizes. Area per student station ranged from 15 sq. ft. to 86 sq. ft.; the average is near 19 sq. ft. per station. Storage areas are commonly underestimated because inadequate allowance is made for passage, and for opening doors and drawers. The advice, "Estimate the storage, double it, and double again," has a good deal of merit. The same comment applies to control rooms for recording.

Special Features.—The B-2's serve not only to instruct the architects. They are also the basis for approval by the college administration, by the office of the Chancellor of the State Colleges, and by the State Department of Finance.

Special acoustical treatment was grudgingly and inadequately provided at Long Beach; it was partially effective at Los Angeles; it was generally good at Northridge; and was provided as a matter of course at Hayward. All four colleges requested a freight elevator; only Hayward was allowed it.

The justification for every special feature had to be particularly detailed and convincing. The experience of the earlier colleges paid off in the later ones.

SCOPE CONFERENCES

Between preparation of the B-2's and approval of the plans, a number of conferences were held. They included the coordinator of building planning and representatives of the music department. On various occasions, representatives of the college architects, the State Department

of Finance, and State Division of Architecture, and consultants on acoustics, ventilation and electronic equipment were drawn in.

Inevitably, many compromises had to be made, most of them quite reasonable. But on occasion, the representatives of the music department had to fight determinedly against proposals which would have weakened or destroyed the basic concepts from which the B-2 Program was developed.

Certain goals for sound isolation were established: 70 db for theory rooms; 60 db for most classrooms and rehearsal rooms; 50 db for practice rooms. Yet at one conference, representatives of the state urged that *half* the classrooms and practice rooms have "proper acoustical treatment and the remainder conventional acoustical treatment." The cost of isolating the "good" rooms from the "bad" proved to be greater than providing proper acoustical treatment for all, so the "half and half" recommendation was killed.

In another case, full sound isolation measures (double walls, acoustical blankets, spring hung ceiling, floating floor slabs) were approved, but acoustical doors were deleted. By proving that this short-circuited the isolation of the entire installation, it was possible to get the doors restored.

One architect developed a beautiful facade with continuous two-story windows regularly spaced along a 240-ft. wall. Forty-eight practice rooms whose spacing did not correspond to the window spacing lay along that wall. The sound isolation problem was insurmountable. The music department and the acoustical consultants had to insist that the entire plan be scrapped and a windowless wall be substituted.

Decisions had to be made on such basics as air conditioning and humidity control. In the middle fifties, the state ruled out air conditioning within 60 miles of the ocean. Yet summer temperatures in the San Fernando Valley frequently reach 105 degrees and occasionally go as high as 118 degrees. The relative humidity in late summer and fall remains around 10-20 percent for long periods (a condition which may seriously damage stringed instruments and pianos).

At Northridge (built in 1959-60) air conditioning was allowed for the large rehearsal rooms only. Design for subsequent refrigerated air conditioning throughout the building was included, but has yet to be installed. Hayward, built in 1964-65, and located on San Francisco Bay was approved for full air conditioning.

It is clear that full and convincing justifications are needed, and that previous experience at other colleges can often be used to advantage.

ARCHITECTURAL PLANS AND SPECIFICATIONS

The most successful music buildings known to the writer are those in which representatives of the music department worked closely with the architects throughout the design period. The matters discussed below are only a few of those on which close liaison proved valuable.

General Plan.—San Fernando Valley State College music building was laid out as a hollow square. Thus a single corridor on each floor provided efficient traffic circulation. All applied music classroom rehearsal rooms, and practice rooms were grouped in a single windowless structure forming the south section of the square. In the north section, a group of music history and theory rooms, music education rooms, and offices were located, together with the music and record library, and recording master control. Thus activities requiring relative quiet were separated from those involving high sound levels. Location of offices away from noise sources is particularly important.

Acoustical Design.—Halls, storage areas, and work rooms were located between classrooms to provide free sound isolation. Heavy structural walls enclose areas of high sound level. Thus concrete shear walls surround the choral and instrumental rehearsal halls, and separate them from the control rooms which lie between. This construction, together with sound locks at all doors, gives complete isolation. No audible sound is transmitted to or from these rooms. The transmission loss is at least 75 to 80 db.

For practical reasons, lower isolation factors were accepted elsewhere; but generally, transmitted sound is not audible when a room is being used for its normal purpose.

The acoustical consultants agreed on the desirability of non-parallel surfaces to reduce resonant peaks. Walls are skewed or splayed and ceilings are sloped. Reverberation periods were set somewhat longer than current practice, since performers thrive in a live environment. Sound absorbent surfaces are divided into patches, and divided between ceilings and upper walls. The "soft ceiling" technique is not satisfactory in music rooms.

Doors and Windows.—Windows were avoided except in the offices. At the request of some of the faculty, windows were installed in two music appreciation classrooms and four music education rooms. In the writer's opinion, this was a mistake. Sound from them fills the central patio and penetrates through the windows of the offices. The teacher also faces the glare of the windows. Windowless construction provides much better sound isolation.

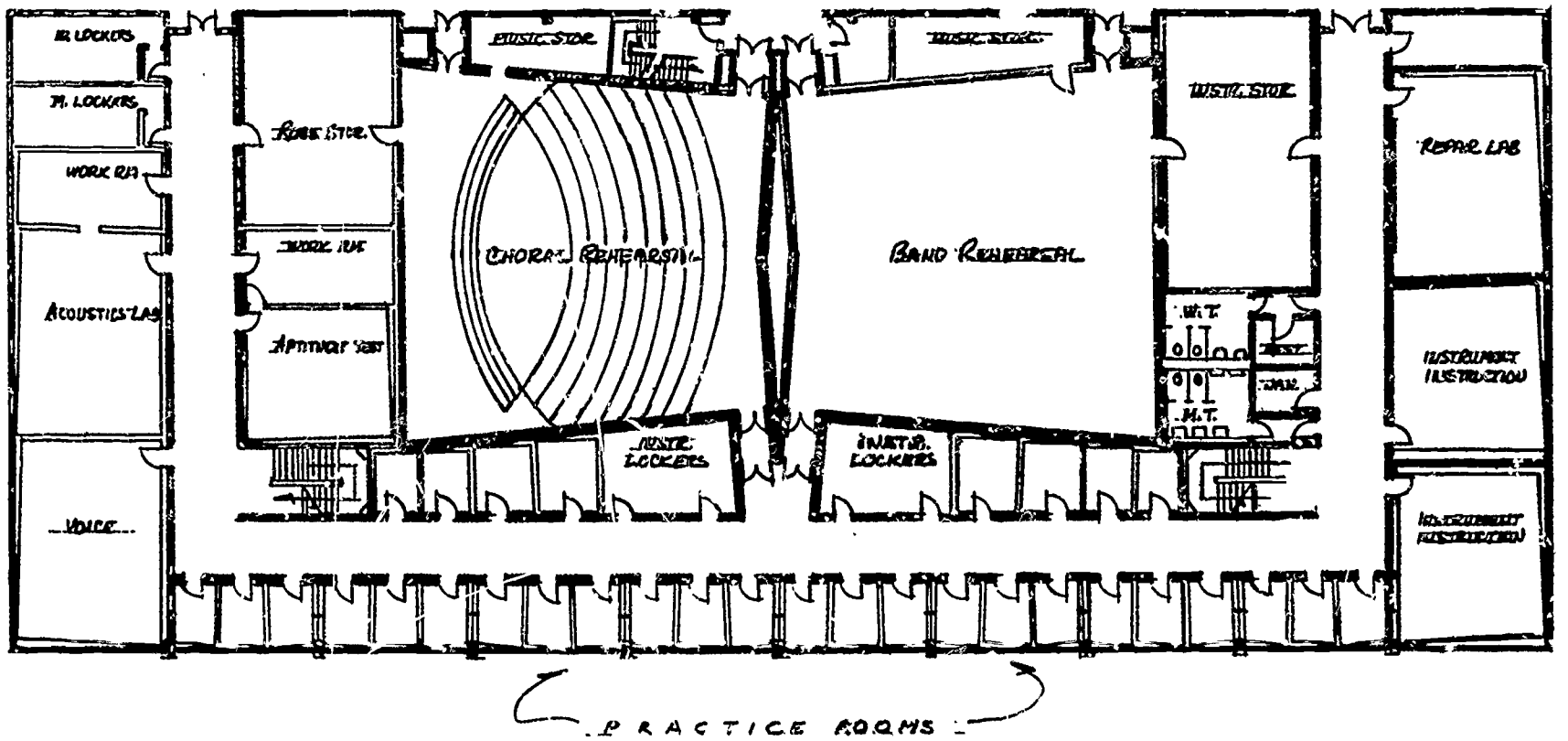
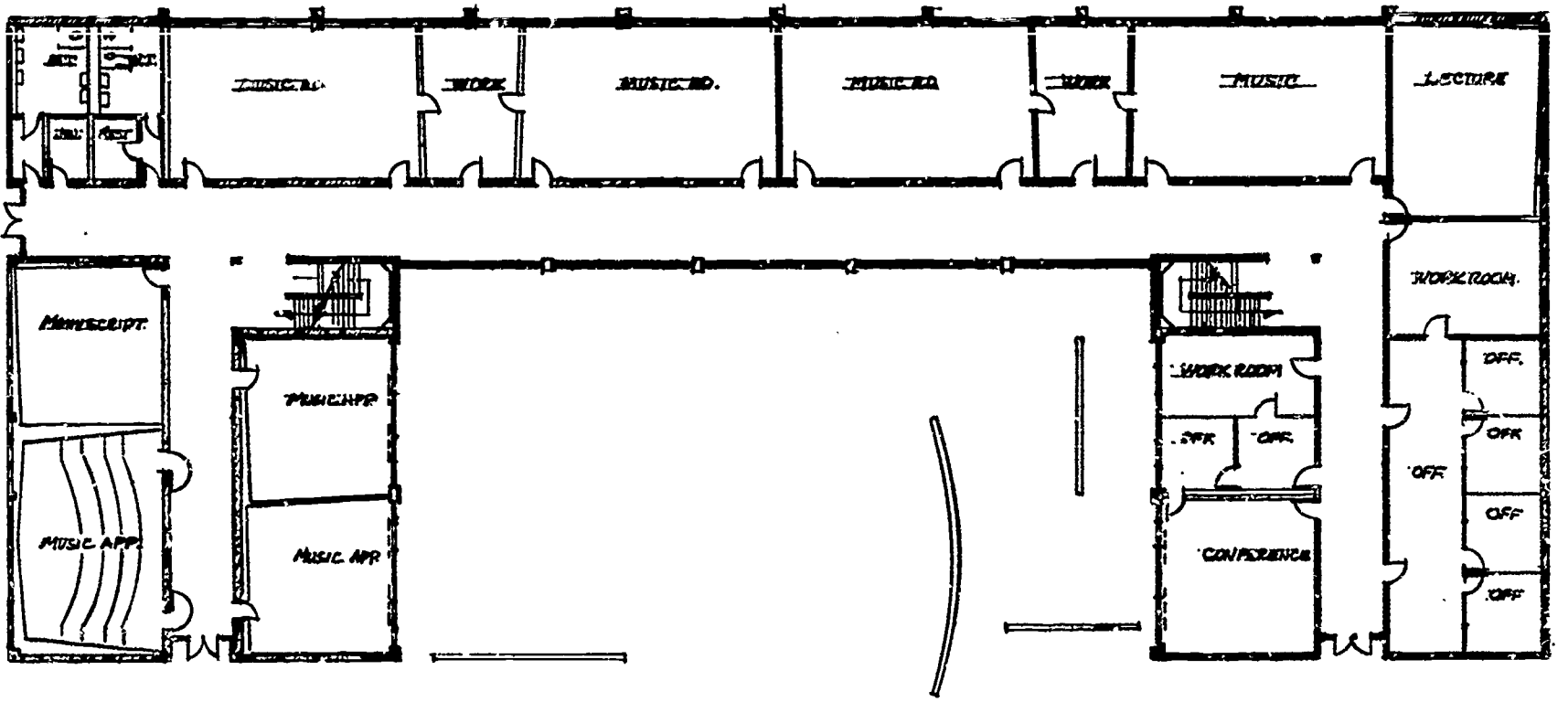

FIRST FLOOR PLAN

SAN FERNANDO VALLEY STATE COLLEGE - MUSIC BLDG.

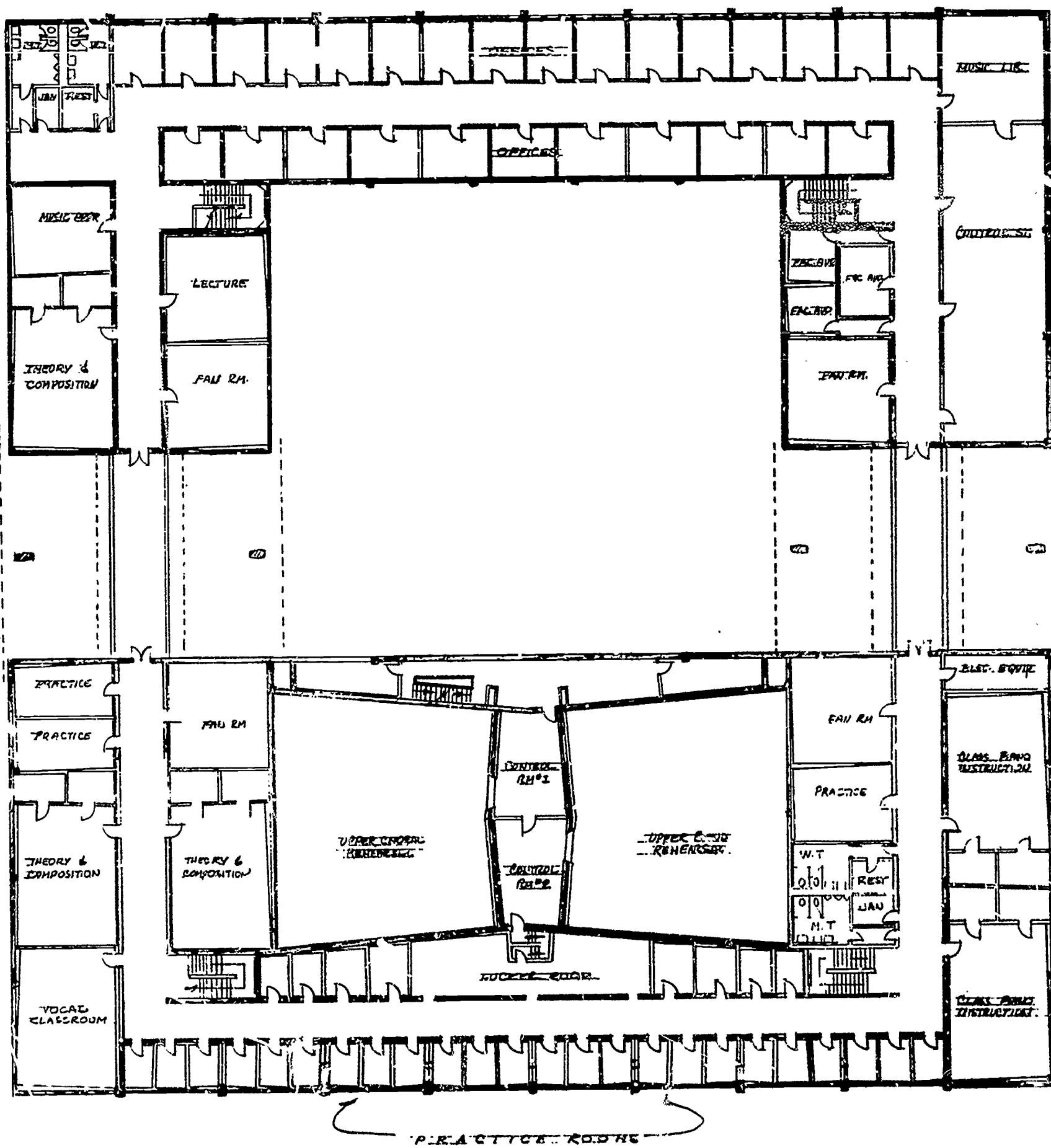

SECOND FLOOR PLAN

SAN FERNANDO VALLEY STATE COLLEGE - MUSIC BLDG.

Sound locks were specified at doors for the larger rooms. All other music rooms have sound retardant doors rated at 35 to 45 db transmission loss as installed. Continuous air seals were specified around the periphery of these doors.

The size of doors was checked to assure that large instruments and pianos could be moved wherever needed.

Noise Suppression.—Floating floor slabs (isolated from the building structure) were required for every classroom and practice room. Transmission of low frequencies from pianos, drums, string basses, and organ speakers is effectively prevented. The same treatment suppresses vibration from fans and compressors, and from electrical transformers.

Ambient noise levels less than 35 db (on the "A" scale of a standard sound level meter) were desired. A large volume, low velocity air distribution system was worked out. Special attention was paid to length of communicating ducts, lining and wrapping with sound absorbent material, and separating sheet metal sections with resilient gaskets. Outlet grills were selected for low noise generation.

Traffic Routing.—Placement of doors, stairs and halls was analyzed carefully. At one stage, it was discovered that a recording technician would have to walk a long block to get from control room to studio. A special stairway was installed to provide direct access.

Rehearsal Rooms.—Two large rehearsal rooms of about 3000 sq. ft. each were planned—one for instrumental and the other for choral purposes. The choral room was designed to double as a recital and lecture hall seating 200. It was therefore provided with theatre type seating on risers. Built-in risers at the front spaced for standing choral rehearsal were also supplied. The upholstered seating was justified because it helped to stabilize the acoustical characteristics regardless of occupancy.

The instrumental room was originally drawn with built-in risers. However, there was so much disagreement among the faculty and among the band and orchestra directors who were consulted that a flat floor was substituted. Collapsible risers were supplied as equipment. Our experience proves this was a wise decision. The flexibility gained has been invaluable.

To secure optimum acoustical conditions, ceilings in both rooms are sloped and average 19 ft. above the floor. Cylindrical diffusers are used on ceilings and walls. A heavy velour curtain is hung 18 in. out from one wall. When fully extended, it reduces the reverberation substantially. It is especially important in the instrumental room, to compensate for occupancy. It also permits excellent recordings.

Recording and Playback Equipment.—A centralized sound distribution system was specified with switching and patching facilities located in the master control room. Microphone and playback lines were specified, linking all classrooms and about two-thirds of the practice rooms with the master control center. A separate, self-contained system was provided for the two large rehearsal rooms. Auxiliary control rooms are located off five of the larger classrooms for later activation.

All conduit, wiring gutters, and a central ground had to be provided as part of the building contract. Precautions were taken to keep low level, medium level, and high level lines separated. Grounding and shielding were carefully controlled. All electrical and electronic conduit was installed so as to prevent acoustical bridging between sound-isolation rooms. As a result, there is no hum or cross-talk in the entire system.

In a rather illogical compromise, all the equipment for the rehearsal hall recording system (two consoles, two tape recorders, tuner, power amplifiers, patch bays, and associated cables, microphones, etc.) was supplied as part of the building contract. Master control installations, speakers for the classrooms and practice rooms, and classroom playback consoles, were classified as equipment to be supplied separately by the college. But enclosures for the classrooms speakers were made part of the building contract!

Color Scheme.—Members of the art department joined the music department in discussions with the architects. It was agreed that a reasonable number of pastel colors, of low saturation and high reflectance, would be desirable. Allison and Rible worked out a set of widely varied combinations of a few tints. Hallways are painted differently on each side, and the hall color wraps around the doorways to become the color of the nearest room wall. Other walls in each room contrast. Areas of factory painted acoustical tile add another variation. The effect is interesting, spacious, and delightful to live with.

"Living" Accommodations.—Locations of restrooms should be checked for convenience. Ours are stacked in diagonally opposite corners of the hollow square. They are not convenient to the large rehearsal halls, and are over 200 ft. from, for example, the faculty music library.

Dressing rooms for donning uniforms and robes were overlooked in the early planning. Two large practice rooms had to be sacrificed for this purpose. Neither they nor the uniform storage room are conveniently located with respect to the restrooms.

Though a satisfactory faculty conference room was provided, a kitchen was not allowed, nor a faculty

lounge. No provision was made for a student lounge, nor for housing the music honorary societies. The omission of such "extra-curricular" conveniences is the source of much annoyance. Offices, practice rooms, or even classrooms have had to be adapted to take care of the need for such amenities.

Keying.—A system placing the door locks under five sub-masters was devised. Each master key operates a related group of doors. For example, the instrumental master handles the instrumental rehearsal room, instrumental classrooms, instrument storage, and the instrument repair laboratory. Few teachers need more than two or three door keys under this system. Part-time teachers and students can still be issued keys to individual doors if they don't need the master.

Construction.—No matter how enlightened and thorough the planning, sloppy construction can defeat the entire concept, especially in a music building where sound control is critical. The contractor's foremen, the architects and the inspectors must watch every detail. The music faculty is at their mercy. A single large nail, bridging two separate stud walls, has been known to destroy the isolation between two rooms. Conduit, junction boxes, and telephone runs may also offer transmission paths.

In San Fernando, all plumbing was isolated from the structure with special hangers, fiberglass packing in oversize access holes, rubber gaskets, etc. Somehow the drainage pipes carrying rain water from the flat roofs were not given the special treatment. Now, whenever it rains (not often in Southern California) one of the music theory rooms radiates a fine, noisy gurgle.

ACCEPTANCE AND CORRECTIONS

Inevitably, the occupation of a new plant reveals a variety of malfunctions and mistakes. The faculty should have some idea of the guarantees and warranties, and particularly of the time factors involved. It is important to report difficulties promptly. It is equally important to resist the sob stories with which sub-contractors and vendors commonly meet requests for corrections.

On the other hand, the builder cannot be held beyond the specifications; he can be held for his own

mistakes and for faulty material, but not for mistakes of the planners. The importance of complete and rigorous specifications cannot be overemphasized. Some funds should be held in reserve to make corrections not attributable to the contractors.

Ventilating and air conditioning apparatus always require a period for balancing out. During this period everyone using the building should faithfully report malfunctions. The San Fernando system works well in winter, but has never functioned adequately in summer because it was designed for refrigerated air conditioning. The refrigeration was to have been supplied by a supplemental appropriation which has never been granted. But noise levels and sound transmission control have proved relatively good.

Sound absorbent surface treatment was omitted from stairways, sound locks, and locker rooms (it was apparently deleted by one of the agencies which had to approve the plan). It was also found necessary to add acoustical wall panels in the master control room and the music library. Reserve funds took care of these cases.

Where sound isolation was reported inadequate, it could usually be traced to poor air seals around the acoustical doors. The seals have required periodic readjustment ever since. Noise and hum attributable to the fluorescent lighting was easily corrected by replacing noisy ballasts.

Transmission loss in relation to four of the classrooms failed to reach the desired 60 db. In each case, independent double steel stud walls were used with a fiberglass blanket between, and finished with metal lath and plaster. The same construction produced entirely satisfactory results elsewhere. In every case where a buffer space (workroom, storage) was interposed between two rooms, the isolation was excellent.

In general, the San Fernando Valley State College music building has worked out well. Higher isolation levels between practice rooms would be desirable as would adequate air conditioning. The built-in risers in the choral room would probably be eliminated and movable platform risers substituted to permit rearrangement. Each faculty member would no doubt like to change some features. But on the whole, it has proved a workable and attractive structure.

San Fernando Valley State College

Building

Campus

SPECIFICATIONS FOR A NEEDED ROOM

Function

Type (lect) (lab) (act) _____

Type of Station _____

Aux. Offices _____

Aux. Rooms _____

Number of Stations _____

Prob. Dimensions _____

Floor Size _____

Recommended Floor _____

FACILITIES

1. Student Stations
(Number and type)

2. Auxiliary room
and storage

3. Auxiliary offices

4. Relation of the auxiliary
room to the specified room

5. Number and dimensions of
storage cabinets; types of
material to be stored; floor
sketches attached

6. Other facilities requiring special placement
(utilities, furnishings, equipment, etc.)

7. Desired Furniture and Equipment
(attached any necessary sheets)

Figure 17.

Bibliography

BOOKS

- Allphin, Willard. *Some Whys and Hows of Modern School Lighting*. Salem, Massachusetts: Sylvania Electric Products, Inc., No date.
- American Association of School Administrators. *American School Buildings*. Twenty-Seventh Yearbook. Washington, D.C.: the Association, a department of the National Education Association, 1949.
- . *Planning America's School Buildings*. Washington, D.C.: the Association, a department of the National Education Association, 1960.
- American Standards Association. *Acoustical Terminology*. New York: the Association, 1960.
- Association of British Theatre Technicians. *Theatre Planning*. Distributed by the Association. No date, no place.
- Audiovisual Education Association of California, Southern Section. *Audiovisual Equipment Standards*. No place, no publisher, no date.
- Bartholomew, Wilmer T. *Acoustics of Music*. New York: Prentice-Hall, Inc., 1942.
- Beranek, Leo L. *Music, Acoustics, and Architecture*. New York: John Wiley & Sons, Inc., 1962.
- Berendt, Raymond D., and George E. Winzer. *Sound Insulation of Floor and Door Constructions*. National Bureau of Standards Monograph 77. Washington, D.C.: U.S. Government Printing Office, 1964.
- Brand, Erick D. *Band Instrument Repairing Manual*. Fifth edition. Elkhart, Indiana: By the author, 1946.
- Brown, J. W., R. B. Lewis, and F. F. Harclerod. *A-V Instruction Materials and Methods*. New York: McGraw-Hill Book Co., 1959.
- Burriss-Meyer, Harold, and E. G. Cole. *Theatres and Auditoriums*. Second edition. New York: Reinhold Publishing Corp., 1964.
- Burriss-Meyer, Harold, and L. S. Goodfriend. *Acoustics for the Architect*. New York: Reinhold Publishing Corp., 1957.
- Burriss-Meyer, Harold, and Vincent Mallory. *Sound in the Theatre*. New York: Theatre Arts Books, no date.
- Bursch, Charles W., and John L. Reid. *High Schools: Today and Tomorrow*. New York: Reinhold Publishing Corp., 1957.
- Caudill, William W. *Toward Better School Design*. New York: F. W. Dodge Corp., 1954.
- Century Theatre Lighting*. New York: Century Lighting, Inc., 1960.
- Clinchy, Evans. *Two Saginaw Middle Schools*. Profiles of Significant Schools. New York: Educational Facilities Laboratories, Inc., 1960.
- . *Wayland Senior High School*. Profiles of Significant Schools. New York: Educational Facilities Laboratories, Inc., 1960.
- The Cost of a Schoolhouse*. New York: Educational Facilities Laboratories, Inc., 1960.
- Culver, Charles A. *Musical Acoustics*. Fourth edition. New York: McGraw-Hill Book Co., 1956.
- Cyr, Frank W., and Henry H. Linn. *Planning Rural Community School Buildings*. New York: Bureau of Publications, Teachers College, Columbia University, 1949.
- DeBernardis, Arno, et al. *Planning Schools for New Media*. Portland, Oregon: Portland State College, 1961.
- Divisible Auditoriums*. New York: Educational Facilities Laboratories, Inc., 1966.
- Doelle, Leslie L. *Acoustics in Architectural Design*. Ottawa, Ontario: Division of Building Research, National Research Council, 1965.
- Dykema, Peter W., and Karl W. Gehrken. *The Teaching and Administration of High School Music*. Boston: C. C. Birchard and Co., 1941.
- Educational Film Library Association. *The EFLA Redbook of Audiovisual Equipment*. New York: EFLA, Inc., 1953.
- Engelhardt, N. L., N. L. Engelhardt, Jr., and Stanton Leggett. *Planning Secondary School Buildings*. New York: Reinhold Publishing Corp., 1949.
- Faris, Gene. *Guidelines for Audiovisual Personnel and Equipment*, 1965. Washington, D.C.: National Education Association, Department of Audiovisual Instruction, 1965. Originally published as "Tentative Guidelines for Audiovisual Personnel and Equipment," *Audiovisual Instruction*, 10, (March 1965), 201-204.
- Fitzroy, Dariel, and John Lyon Reid. *Acoustical Environment of School Buildings*. Technical Report 1. New York: Educational Facilities Laboratories, Inc., 1963.
- Florida State Department of Education. *Building for Dynamic Music Teaching*. Tallahassee: the Department, no date.
- Furrer, Willi. *Room and Building Acoustics and Noise Abatement*. Translated from German by Evelyn Robinson and Peter Lord. Toronto, Ontario: Butterworth & Co., 1964.
- Granville, Walter C. *Color Planning for Hospitals and Schools*. Chicago: Mobil Finishes Company, Inc., 1962.
- Herrick, John H., et al. *From School Program to School Plant*. New York: Henry Holt and Co., 1956.
- Hindsley, Mark H. *School Band and Orchestra Administration*. New York: Boosey & Hawkes, Inc., 1940.
- Hoffer, Charles R. *Teaching Music in the Secondary Schools*. Belmont, California: Wadsworth Publishing Co., Inc., 1964.
- Holland, Ben F., Horace C. Hartsell, and Raymond L. Davidson. *Audiovisual Materials and Devices*. Revised edition. Lubbock, Texas: Rodgers Litho., 1958.
- Holt, E. E. *Guidelines for School Building Planning*. Columbus: Ohio State Department of Education, 1964.
- House, Robert W. *Instrumental Music for Today's Schools*. Englewood Cliffs, New Jersey: Prentice-Hall, Inc., 1965.
- Hovey, Nilo W. *The Administration of School Instrumental Music*. Rockville Centre, New York: Belwin, Inc., 1952.
- Ingerslev, Fritz. *Acoustics in Modern Building Practice*. London: The Architectural Press, 1952.
- Illuminating Engineering Society Lighting Handbook*. New York: the Society, 1952.
- An Interim Report School Construction Systems Development*. New York: Educational Facilities Laboratories, Inc., 1965.
- Jones, Archie N., et al. *Music Education in Action*. Boston: Allyn and Bacon, Inc., 1960.
- Jones, L. Bruce. *Building the Instrumental Music Department*. New York: Carl Fischer, Inc., 1949.
- Jordalen, Marion. *How To File and Catalog Records Simply and Effectively*. California State Department of Education Bulletin No. AV-232. Sacramento, California: the Department, 1954.
- Kentucky State Department of Education. *Music Facilities: New Remodeling: Planning*. Frankfort: the Department, no date.
- Knudsen, Vern O. *Architectural Acoustics*. New York: John Wiley & Sons, Inc., 1932.
- Knudsen, Vern O., and Cyril M. Harris. *Acoustical Designing in Architecture*. New York: John Wiley & Sons, Inc., 1950.
- Large Lamp Department, General Electric Co. *Electrical Space Conditioning*. Cleveland: General Electric Co., no date.

- Levin, Robert E. *The Visual Environment in Today's Schools*. Educational Administration Monograph No. 6. Stanford, California: School of Education, Stanford University, 1956.
- Lighting for Education*. New York: Holophane Co., Inc., 1965.
- Lite-Therm Design Manual*. Conyers, Georgia: Environmental System Corporation, Lithonia Lighting Inc., 1965.
- Little Theatres from Modest Spaces*. Bulletin No. 107. Chicago: Hub Electric Company, Inc., 1962.
- McQuade, Walter, ed. *Schoolhouse*. New York: Simon and Schuster, 1958.
- Miller, James Hull. *New School Stages for Old*. Bulletin No. 105. Chicago: Hub Electric Company, Inc., 1962.
- Morgan, Hazel N., ed. *Music in American Education*. Source Book Two. Washington, D.C.: Music Educators National Conference, 1955.
- Murphy, Judith. *Middle Schools*. Profiles of Significant Schools. New York: Educational Facilities Laboratories, Inc., 1965.
- _____. *School Scheduling by Computer*. New York: Educational Facilities Laboratories, Inc., 1963.
- Music Educators National Conference. "Music Education Materials: A Selected Bibliography." *Journal of Research in Music Education*, 7 (Spring 1959).
- National Audiovisual Association. *The Audiovisual Equipment Directory*. Eleventh edition. Fairfax, Virginia: NAVA, 1965.
- National Council on Schoolhouse Construction. *American Standards Association Guide for School Lighting*. New York: Illuminating Engineering Society, 1962.
- National Council on Schoolhouse Construction. *Guide for Planning School Plants*. East Lansing, Michigan: NCSC, 1964.
- _____. *Secondary School Plant Planning*. Nashville, Tennessee: NCSC, 1957.
- National Education Association, Department of Audiovisual Instruction. *Planning Schools for Use of Audiovisual Materials*. No. 1. Classrooms. Washington, D.C.: the Department, 1952.
- _____. *Planning Schools for Use of Audiovisual Materials*. No. 2. Auditoriums. Washington, D.C.: the Department, 1953.
- _____. *Planning Schools for Use of Audiovisual Materials*. No. 3. The Audiovisual Instructional Materials Center. Washington, D.C.: the Department, 1954.
- National Society for the Study of Education. *The Planning and Construction of School Buildings*. Thirty-Third Yearbook, Part 1. Bloomington, Illinois: Public School Publishing Co., 1934.
- New York State Education Department. *Planning the Music Suite*. Albany: the Department, 1963.
- Nimnicht, Glendon P., and Arthur R. Partridge. *Designs for Small High Schools*. Greeley, Colorado: Educational Planning Service, Colorado State College, 1962.
- Odell, C. W. *Standards for the Evaluation of Secondary School Buildings*. Ann Arbor, Michigan: Edwards Brothers, Inc., 1950.
- Olson, Harry F. *Elements of Acoustical Engineering*. Second edition. New York: D. Van Nostrand Co., Inc., 1947.
- _____. *Musical Engineering*. New York: McGraw-Hill Book Co., 1952.
- Parkin, Peter H. *Acoustics, Noise, and Buildings*. London: Faber and Faber, 1958.
- Peters, Jon S., ed. *Trends in School Planning*. Stanford, California: School Planning Laboratory, Stanford University, 1955.
- Prescott, Gerald R., and Lawrence W. Chidester. *Getting Results with School Bands*. New York: Carl Fischer, Inc., and Paul A. Schmitt Music Co., 1938.
- Rettinger, Michael. *Applied Architectural Acoustics*. Brooklyn, New York: Chemical Publishing Co., Inc., 1947.
- Richardson, E. G. *Acoustics for Architects*. London: Edward Arnold & Co., 1945.
- Sabine, Hale J. *Less Noise, Better Hearing*. Chicago: The Celotex Corporation, 1941. Celotex Corporation, 120 S. La Salle Street, Chicago, Illinois 60606.
- Sabine, Paul E. *Acoustics and Architecture*. New York: McGraw-Hill Book Co., 1932.
- Sabine, Wallace C. *Collected Papers on Acoustics*. New York: Dover Publications, Inc., 1922.
- Shetler, Donald J., ed. *Film Guide for Music Educators*. Washington, D.C.: Music Educators National Conference, a department of the National Education Association, 1961.
- Snyder, Keith D. *School Music Administration and Supervision*. Second edition. Boston: Allyn and Bacon, 1965.
- Sumpton, Merle R., and Jack L. Landes. *Planning Functional School Buildings*. New York: Harper & Bros., 1957.
- Tiede, Clayton H. *The Practical Band Instrument Repair Manual*. Dubuque, Iowa: Wm. C. Brown Co., 1962.
- Sur, William R., and Charles F. Schuller. *Music Education for Teenagers*. Second edition. New York: Harper & Row, Publishers, 1966.
- Watson, Floyd R. *Acoustics of Buildings*. Third edition. New York: John Wiley & Sons, Inc., 1941.
- Wohlens, A. E. *A Manual for Planning a Secondary School Building*. Columbus, Ohio: Bureau of Educational Research, The Ohio State University, no date.

ARTICLES

- Beck, A. L. "Story of Portable Stages." *American School Board Journal*, 151 (December 1965), 30-31.
- Beranek, Leo L. "Acoustics of the Frederic R. Maan Concert Hall, Tel Aviv, Israel." *Journal of the Acoustical Society of America*, 31 (July 1959), 382-892.
- Beranek, Leo L., et al. "Acoustics of Philharmonic Hall, New York, During Its First Season." *Journal of the Acoustical Society of America*, 36 (July 1965), 1247-1262.
- Best, Clarence J. "Building Facilities for Music Education." *School Executive*, 65 (March 1946), 57-72.
- _____. "Equipping the Music Department." *American School and University*, 18 (1946), 184-191.
- Bieseke, R. L., Jr. "New Light on School Lighting." *American School Board Journal*, 113 (July 1946), 28-31, 69.
- Blackwell, H. R. "A General Quantitative Method for Evaluating the Visual Significance of Reflected Glare, Utilizing Visual Performance Data." *Illuminating Engineering*, 58 (April 1963), 161.
- Blankenship, Joseph, R. Bernard Fitzgerald, and R. N. Lane. "Comparison of Objective and Subjective Observations on Music Rooms." *Journal of the Acoustical Society of America*, 27 (July 1955), 774-780.
- Blandell, W. Irvin, and Lawrence B. Perkins. "The School Auditorium—Its Purpose and Design." *American School and University*, 25 (1953), 271-276.
- Bolt, Richard H., and Robert B. Newman. "Architectural Acoustics: Article 1: Basic Planning Aspects." *Architectural Record*, 107 (April 1950), 165-168, 244-248.
- _____. "Architectural Acoustics: Article 3, Part Two: Reverberation." *Architectural Record*, 108 (Nov. 1950), 158-160, 220-224.

- Brubaker, Charles William. "Make the Auditorium Work for You." *Overview*, 4 (April 1963), 40-44.
- BruXner, Mervyn. "Musicians and Architects." *Journal of Education* (London), 88 (May 1956), 212-213.
- Carbonell, Jaime R., and José L. Zuccoli. "Volume per Seat and Variation of the Reverberation Time with the Size of the Audience." *Journal of the Acoustical Society of America*, 33 (June 1961), 757-759.
- Carter, Elwyn. "Planning High School Music Areas." *American School Board Journal*, 136 (March 1958), 38-40.
- . "School Building Planning for Music and Drama." *Music Educators Journal*, 45 (June-July 1959), 37-41.
- Clapp, P. G. "The Music Unit." *American School and University*, 17 (1945), 132-133.
- Clapp, Wilfred F., and Laura V. Shaw. "Essentials of Stage Design for Schools." *American School and University*, 26 (1954), 159-162.
- "Colorado School Sets Stage for New Auditorium Design." *Nation's Schools*, 72 (December 1963), 47-51.
- Connor, A. K. "Models as an Aid in the Acoustical Design of Auditoria." *Acustica*, 9 (1959), 407-408.
- Crocker, Allen S. "The Heating and Ventilating System and Soundproofing for the Eastman Theater and School of Music." *American Architect*, 123 (Feb. 28, 1923), 200-202.
- Crouch, C. L. "Better Lighting Through Research." *American School and University*, 38 (May 1966), 47-50.
- . "The Relation Between Illumination and Vision." *Illuminating Engineering*, 40 (Nov. 1945), 747-784.
- "Current Trends in School Facilities." *School Management*, No. 7 (July), annually.
- De Claine, Faber. "The Space Stage: Fad or Future." *American School Board Journal*, 152 (May 1966), 8-9, 59.
- Franz, Gary. "ABC's of Buying Seating." *American School Board Journal*, 151 (December 1965), 26-27.
- George, N. L. "Selection of Stage Equipment." *American School Board Journal*, 151 (December 1965), 28-29.
- Gibson, Charles D. "How Do You Plan What To Tell the Architect." *Overview*, 1 (January 1960), 66-68.
- . "Today's Concepts in School Lighting." *American School Board Journal*, 150 (June 1965), 21-24.
- Goodfriend, Lewis S. "Acoustical Materials for Schools." *American School Board Journal*, 147 (Nov. 1963), 21-23.
- . "Acoustics for School Music Departments." *Sound*, 2 (Jan.-Feb. 1963), 28-32.
- Gores, Harold B. "Schoolhouse in Transition." *The Changing American School. Sixty-Fifth Yearbook, Part II.* National Society for the Study of Education. Chicago: the Society, 1966.
- Graybill, E. S. "Resolve Three Problems on a Single Plane: Lighting, Air Transfer, Acoustics." *American School Board Journal*, 150 (June 1965), 38-40.
- Gregory, Leslie R. "Music Building for Future Teachers." *Nation's Schools*, 36 (Aug. 1945), 36-37.
- Guth, Sylvester K., and Eldon H. White. "Challenge of Tomorrow's Lighting." *American School Board Journal*, 150 (June 1965), 25-27.
- Hamann, Ray. "Kimberly's Balanced Heat System Also Balances Annual Budget." *American School Board Journal*, 149 (August 1964), 26-27.
- Hamne, Richard N. "Laboratory Measurements of Sound Transmission Through Suspended Ceiling Systems." *Journal of the Acoustical Society of America*, 31 (Nov. 1961), 1523-1530.
- Harris, Cyril M. and Charles T. Molloy. "The Theory of Sound Absorptive Materials." *Journal of the Acoustical Society of America*, 24 (Jan. 1952), 1-7.
- Harrison, Ward. "Glare Ratings." *Illuminating Engineering*, 40 (Sept. 1945), 525-541.
- Harrison, Ward, and Phelps Meaker. "Further Data on Glare Ratings." *Illuminating Engineering*, 42 (Feb. 1947), 153-168.
- Henrikson, R. W. "Present Furniture Trends Promise Exciting Future." *American School Board Journal*, 150 (March 1965), 26-27.
- Higgins, Thomas J. "Making Room for Music." *Nation's Schools*, 42 (Nov. 1948), 39.
- Holmes, Warren S. "The Contribution of Color to Educational Environment." *American School and University*, 11 (1939), 31-36.
- Hosler, Fred W., and J. Chester Swanson. "Ways of Modernizing Old School Buildings." *American School and University*, 19 (1947), 171-176.
- Hosler, Fred W., et al. "The School Auditorium." *School Executive*, 45 (June 1946), 33-50.
- "How To Divide and Conquer Auditorium Space." *School Management*, (May 1966), 124-139.
- "How To Select Acoustical Materials." *Architectural Record*, 138 (July 1965), 187-188; and 138 (August 1965), 185-186.
- Hunt, J. L. "Music Building for Southern University." *American School and University*, 27 (1955), 351-354.
- Illuminating Engineering Society, American Institute of Architects. "The American Standard Practice for School Lighting." *American School and University*, 21 (1949), 266-283.
- Ingard, K. U., et al. "American Standard Recommended Practice for Laboratory Measurement of Air-Borne Sound Transmission Loss of Building Floors and Walls." *Journal of the Acoustical Society of America*, 31 (Jan. 1959), 76-78.
- Jaffe, Christopher. "Sound Improvement via the Acoustical Shell." *Instrumentalist*, 20 (Feb. 1966), 40-41.
- James, Leonard V. "Good Seeing Conditions in Schools, from the Standpoint of the Illuminating Engineer." *American School and University*, 19 (1947), 93-99.
- Johnson, Beverly E. "Adjustable Ceiling for Band Room Acoustical Control." *Music Educators Journal*, 44 (Jan. 1958), 54.
- Johnson, Russell. "Acoustics for Music Performance." *Musical America*, 80 (Feb. 1960), 6-6, 75, 136, 138, 159; and 80 (March 1960), 6-8, 45.
- Kamphoefner, Henry L. "Three Basic Music Shells." *Music Educators Journal*, 29 (Jan. 1943), 24-25.
- Kent, Earle L. "Acoustics of Music Rooms." *Instrumentalist*, 20 (Feb. 1966), 42-44.
- Klepper, David K. "Acoustic Advisor Discusses Sound Absorber Problems." *Diapason*, 49 (Oct. 1, 1958), 18.
- . "Acoustics of the Jacksonville Civic Auditorium." *Journal of the Acoustical Society of America*, 35 (Oct. 1963), 1501-1506.
- Knudsen, Vern O. "Acoustics of Music Rooms." *Journal of the Acoustical Society of America*, 2 (1931), 434-467.
- . "Architectural Acoustics." *Scientific American*, 209 (Nov. 1963), 78-92.
- . "Review of Architectural Acoustics During the Past Twenty-Five Years." *Journal of the Acoustical Society of America*, 26 (Sept. 1954), 646-650.
- Knudsen, Vern O., and Cyril M. Harris. "Reverberation Time Calculations." *Architectural Record*, 104 (Nov. 1948), 157.
- Konarski, M. M. "A Music Room Plus." *Nation's Schools*, 36 (Aug. 1945), 34-35.
- "Kresge Auditorium at M.I.T." *American Organist*, 41 (April 1958), 127-134.
- Kurtze, G., and B. G. Watters. "New Wall Design for High Transmission Loss or High Damping." *Journal of the Acoustical Society of America*, 31 (June 1959), 739-748.

- Lane, R. N. "Noise Control in Schools." *Noise Control*, 3 (July 1957), 27-34.
- Lane, R. N., and E. E. Mikeska. "Problems of Field Measurement of Transmission Loss as Illustrated by Data on Lightweight Partitions Used in Music Buildings." *Journal of the Acoustical Society of America*, 33 (Nov. 1961), 1531-1535.
- _____. "Study of Acoustical Requirements for Teaching Studios and Practice Rooms in Music School Buildings." *Journal of the Acoustical Society of America*, 27 (Nov. 1955), 1087-1091.
- Lane, R. N., Frank Seay, and C. P. Boner. "An Inexpensive Acoustic Treatment for Gymnasiums, Civic Coliseums, and Similar Structures." *Journal of the Acoustical Society of America*, 24 (March 1952), 127-128.
- Lewis, Russell L. "Storage Facilities in the High School Music Department." *American School Board Journal*, 130 (Feb. 1955), 60-61, 94.
- "Lighting for Better Seeing." *American School and University*, 38 (January 1966), 54-56.
- "Lighting Techniques for the ETV Studio." *American School and University*, 38 (January 1966), 58-59.
- Little, Robert M. "The University of Miami School of Music." *American School and University*, 28 (1956), 375-380.
- Lochner, J. P. A., and P. Meffert. "Analysis of Reflection Patterns in Auditoria." *Journal of the Acoustical Society of America*, 35 (Sept. 1963), 1429-1431.
- Manning, William R., and Lionel R. Olsen. "Air Conditioning: Keystone of Optimal Thermal Environment." *American School Board Journal*, 149 (August 1964), 22-23.
- _____. "Educational Possibilities of Color." *American School Board Journal*, 146 (January 1963), 39-40.
- Mariner, Thomas. "Critique of the Reverberant Room Method of Measuring Air-Borne Sound Transmission Loss." *Journal of the Acoustical Society of America*, 33 (Aug. 1961), 1131-1139.
- Masterson, C. T., and C. J. Allen. "Lighting and Color in the Music Room." *Music Journal*, 12 (July 1954), 20-22.
- Meyer, Erwin. "Definition and Diffusion in Rooms." *Journal of the Acoustical Society of America*, 26 (Sept. 1954), 630-636.
- Millgate, Irvine H., and Roger S. Hall. "Audiovisual Aids Facilities in a New Educational Building." *American School and University*, 22 (1950-51), 281-292.
- "A Modern High School Music Building." *Music Educators Journal*, 42 (Nov.-Dec. 1955), 39-40.
- Moore, G. A. "Suggestions for Planning High School Music Facilities." *American School and University*, 30 (1958), 235-238.
- "Music Buildings, Rooms and Equipment." *Music Educators Journal*, 41 (Jan. 1955), 16-18.
- "Music Rooms and Equipment." *Bulletin of the National Association of Secondary School Principals*, 43 (March 1959), 38-39.
- "The New Building for the School of Music, University of Michigan." *Music Educators Journal*, 51 (Nov.-Dec. 1964), 70.
- "New Buildings for Music." *Instrumentalist*, 19 (Jan. 1965), 33-40.
- Newman, Robert B. "Notes on How To Improve Sound Insulation in the School and Hearing Conditions in the Classroom." *Architectural Forum*, 91 (Oct. 1949), 152-153.
- Nickerson, James F. "Planning for the Acoustics of Music Rooms." *Kansas Music Review*, 15 (Feb. 1953), 11-15.
- _____. "Planning for the Acoustics of Music Rooms. Part II: Excluding Unwanted Sound." *Kansas Music Review*, 15 (March 1953), 21-26.
- _____. "Planning for the Acoustics of Music Rooms. Part III: Controlling Wanted Sound." *Kansas Music Review*, 15 (May 1953), 19-25.
- _____. "Schoolroom Acoustics." *University of Kansas Bulletin of Education*, 7 (Nov. 1952), 17-21.
- _____. "Schoolroom Acoustics. Part II: The Control of Unwanted Sound." *University of Kansas Bulletin of Education*, 7 (Feb. 1953), 44-48.
- _____. "Schoolroom Acoustics. Part III: The Control of Wanted Sound." *University of Kansas Bulletin of Education*, 7 (May 1953), 83-90.
- Nickson, A. F. B., and R. W. Muncy. "The Acoustic Conditions Accepted by Listeners in an Auditorium." *Acustica*, 9 (1959), 316-320.
- Niemi, Allan L. "Housing School and Community Music Activities." *American School Board Journal*, 125 (Aug. 1952), 44-46, 64.
- _____. "The Music Department: Its Location and Equipment." *American School Board Journal*, 125 (Oct. 1952), 37-38, 92.
- _____. "Planning the Music Department-III." *American School Board Journal*, 125 (Dec. 1952), 42-44.
- Nimura, Tadamoto, and Kimio Shibayama. "Effect of Splayed Walls of a Room on the Steady-State Sound Transmission Characteristics." *Journal of the Acoustical Society of America*, 29 (Jan. 1957), 85-93.
- Northwood, T. D. "Sound-Insulation Ratings and the New ASTM Sound-Transmission Class." *Journal of the Acoustical Society of America*, 34 (April 1962), 493-501.
- Northwood, T. D., and E. J. Stevens. "Acoustic Design of the Alberta Jubilee Auditoria." *Journal of the Acoustical Society of America*, 30 (June 1958), 507-516.
- Olney, Benjamin, and Roy S. Anderson. "Acoustics of the Rochester (New York) War Memorial Auditorium." *Journal of the Acoustical Society of America*, 29 (Jan. 1957), 94-98.
- Parkin, P. H., et al. "The Acoustics of the Royal Festival Hall, London." *Journal of the Acoustical Society of America*, 25 (March 1953), 246-259.
- Pearce, Frederick W. "Basic Physical Needs in Today's Music Department." *School Music News*, 12 (April 1949), 21-22.
- Peterson, Wilbur J. "Sound Control and the Rehearsal Room." *Educational Music Magazine*, 34 (Nov.-Dec. 1954), 12-13, 50-53.
- Putnam, Russell C. "The American Standard Practice for School Lighting—Its Preparation, Use, and Value." *American School and University*, 21 (1949) 284-287.
- _____. "Quality Lighting in Schools." *Illuminating Engineering*, 42 (April 1947), 471-483.
- Reeves, William A. "Auditorium-Bandroom at Woodboro, Texas." *American School and University*, 30 (1958), 239-242.
- Rennick, J. H. "Music Rooms and Equipment: Efficiency vs. Cost." *School Musician*, 31 (May 1960), 36-39.
- Richards, Roy L., and Robert B. Kraft. "Sound Control in Difficult Areas." *American School Board Journal*, 147 (Nov. 1963), 33-41.
- Rienstra, Albert R. "Gap Between Good Acoustics for Speech and for Music." *Journal of the Acoustical Society of America*, 37 (March 1965), 530-531.
- Roaden, O. Paul. "Location of the Auditorium." *American School Board Journal*, 151 (December 1965), 33-34.
- Sabine, Hale J. "The Absorption of Noise in Ventilating Ducts." *Journal of the Acoustical Society of America*, 12 (July 1940), 53-57.
- _____. "Improving Acoustics in Music Rooms." *Instrumentalist*, 11 (Feb. 1957), 27, 31.
- Schroeder, M. R. "New Method of Measuring Reverberation Time." *Journal of the Acoustical Society of America*, 37 (March 1965), 409-412.

- Schultz, Theodore J., and B. G. Watters. "Propagation of Sound Across Audience Seating." *Journal of the Acoustical Society of America*, 36 (May 1964), 885-896.
- Sessler, G. M., and J. E. West. "Sound Transmission over Theatre Seats." *Journal of the Acoustical Society of America*, 36 (Sept. 1964), 1725-1732.
- Shankland, Robert S., and Edward A. Flynn. "Acoustics of Severance Hall." *Journal of the Acoustical Society of America*, 31 (July 1959), 866-871.
- Sharp, J. Stanley. "Auditoriums of the Future." *American School Board Journal*, 151 (December 1965), 19-21.
- Silverthorn, Harold. "Thirteen Cherished Illusions About School Building Planning." *American School Board Journal*, 152 (January 1966), 13-14.
- Sleeper, Harold R. "Noise Reduction—Acoustical Materials: Their Selection and Use." *Architectural Record*, 95 (March 1944), 101-109. Also see corrections in 96 (July 1944), 113.
- Spahn, Ronald A. "Problems in Planning Music Facilities." *Indiana University School of Education Bulletin*, 32 (Sept. 1956), 50-56.
- Summerville, D. G. "How To Buy School Seating." *School Management*, (May 1966), 143-153.
- Veneklasen, Paul S., and Jerry P. Christoff. "Seattle Opera House—Acoustical Design." *Journal of the Acoustical Society of America*, 36 (May 1964), 903-910.
- "Video Tape for Flexible Programming." *American School and University*, 38 (April 1966), 47-48.
- Waite, L. L. "Educational Specification—Key to Good Buildings." *American School and University*, 38 (March 1966), 32-33, 50.
- Watters, B. G. "Transmission Loss of Some Masonry Walls." *Journal of the Acoustical Society of America*, 31 (July 1959), 898-911.
- Wesler, Warren A. "A Compact, Useful and Economical School Music Suite." *Music Educators Journal*, 45 (Sept.-Oct. 1958), 78-79.
- Williams, Lloyd J. "Auditoriums." *Nation's Schools*, 67 (May 1961), 103-107.
- . "Music Rooms." *Nation's Schools*, 67 (May 1961), 108-109.
- Winckel, Fritz W. "Optimum Acoustic Criteria of Concert Halls for the Performance of Classical Music." *Journal of the Acoustical Society of America*, 34 (Jan. 1962), 81-85.
- Wright, Al G. "Housing the School Music Department." *Music Educators Journal*, 37 (April-May 1951), 20-21, 29.
- Young, Wilbur. "Music and Our Schools." *Indiana University School of Education Bulletin*, 32 (Sept. 1956), 1-3.

UNPUBLISHED MATERIAL

- Jordan, Wayne N. "Planning Music Facilities for the Secondary Schools." Ed.D. dissertation, Stanford University, Stanford, California, 1956.
- Pottle, Ralph R. "Intonation Problems in School Bands." Ph.D. dissertation, George Peabody College for Teachers, Nashville, Tennessee, 1943.
- Waterman, Charles R. "Planning for Music Rooms and Buildings" Ed.D. dissertation, University of Wyoming, Laramie, Wyoming, 1955.

Index

A

Acoustics, 7, 11, 27-28, 31-33, 37, 39, 57, 64, 65, 67-68, 82, 106-107, 110
 Air conditioning, 32, 51, 64-65, 67, 70, 77-78, 82, 107, 111
 Air seals, 65-66, 110-111
 Amplifier, 75, 77, 93-94, 97, 110
 Apron, 50, 55-57, 69, 72
 Art rooms, *see* fine arts
 Audiometer, 94
 Auditorium, 1, 5, 10, 13, 16-17, 19, 27, 38-39, 45, 47-49, 52-55, 57-60, 67, 69, 70-71, 73, 75, 77, 82, 85-86, 88, 93-94, 97, 101-102, 104, 106
 Average class size, 104

B

Background noise, 67, 70
 Ballasts, 88, 111
 Battens, 51-52, 55
 Blackboards, *see* chalkboards
 Box office, 38, 53, 60
 Brightness ratio, 80-81
 Bulletin board, 32, 81, 100

C

Cabinet, percussion, 100-101
 Cabinet, storage, 32, 37, 40-43, 45, 49
 Cafeterias, 1, 10
 Cafetorium, 39
 Carpeting, 68, 81
 Carre., 35
 Ceiling, 27-28, 32, 39, 41, 51, 57, 67-73, 75, 81-82, 85-86, 107, 110
 Ceiling slots, 54-56
 Cello, 27, 65, 89-90, 100
 Chairs, 8, 27, 29, 32, 38, 45, 70, 99, 100
 Chalkboard, 27, 31-33, 38, 68, 81, 83, 86, 96, 100
 Checklist, 1, 11, 47
 Choral room, 2, 16, 28-29, 31, 40, 68, 80, 105, 110
 Classrooms, 3, 7-8, 17, 19, 20, 24, 27, 29, 32-33, 35, 37-39, 45, 64, 66, 68, 82-86, 97, 104, 107, 110-111
 Classroom utilization, 104
 Class piano room, 24, 32-33, 90, 106
 Coat racks, 33, 102
 Color, 80-87, 110
 Combinations, 24, 31, 38-39
 Communication system, 53, 59
 Conduits, 27, 51, 65, 88, 95, 106, 110-111
 Consultants, 5, 10, 38-39, 47, 89, 104, 107
 Control room (booth), 24, 27, 34, 38, 44-45, 77, 93, 105-107, 110-111
 Conversion, 10
 Corridors, 13, 16, 41, 66-67, 107, 110
 Curtains, 13, 31, 50-51, 55, 64, 68, 70, 73, 77, 85, 102, 110
 Cyclorama, 51, 55

D

Dance, 36, 38-39
 Dial access installations, 88
 Dimmer, 38, 55, 57, 60
 Diffusion, light, 80-81
 Diffusion, sound, 27, 70-71, 75, 110

Drama, 17, 38-39, 47, 51, 53, 55, 57
 Draperies, *see* curtains
 Dressing rooms, 17, 38, 43, 49, 105, 110
 Doors, 2, 10, 15, 32, 38, 41, 43, 52, 65-67, 107, 110-111
 Ducts, 32, 51, 65-66, 77-78, 110
 Duplicating room, 45
 Dynalevel, 99

E

Earphones, 34, 87-88, 94-95
 Elevator, 13, 20, 23, 46, 106
 Enrollment, 6-7, 11, 39, 104, 106
 Ensemble rooms, 8, 30, 32, 35, 37, 40, 105
 Equipment, electronic, 45, 59, 60, 77, 89-99, 107, 110
 Equipment, stage, 49, 51, 53, 57, 59, 71
 Exits, 2, 13, 52, 60

F

Filters, sound, 32
 Fine arts, 13-14, 35, 38-39, 61-63, 80
 Floor pockets, 55
 Footlights, 53-55

G

General music, 6, 11, 34, 45
 Glare, 107
 Grid, 48-51
 Gymnasium, 1, 10, 13, 39, 77

H

Harp dolly, 102-103
 Heating, 11, 41, 51, 77-78, 106
 Humidity control, 11, 41, 78, 107

I

Instrument repair room, 10, 31, 45, 105
 Instrumental rooms, 27-28, 31-32, 68-69, 78, 105, 110-111

K

Keys, 10, 111
 Kitchen, 111

L

Laboratory, acoustics, 106
 Laboratory, art, 14, 39
 Laboratory, language, 1, 90
 Laboratory, psychology of music, 106
 Laboratories, science, 1
 Laboratories, theory, 1, 7, 35, 105
 Lavatories, 45-46, 60, 106, 110
 Library, 1, 7, 8, 10, 14, 24, 31, 38-40, 43, 45, 50, 67, 100, 104, 107, 110-111
 Light bridge, 51, 55
 Lighting, 11, 13, 60, 64, 78-82, 84-88, 100
 Lighting, stage, 48-49, 51, 53-56
 Listening facilities, 7, 24, 34-35, 38, 43, 45, 67, 87-88, 94, 106
 Little theatre, *see* recital hall
 Loading dock, 13, 38, 46
 Lobby, 60, 67
 Location, 1, 11, 13-23, 35, 38, 45, 107-108

Loft, *see* grid
 Loudspeakers, 71, 74-75, 77, 94, 96-97, 99, 110
 Lounge, 46, 60, 111

M

Maintenance, 81-83, 87, 89, 91-92, 106
 Metronomes, 96
 Microphones, 17, 27, 31, 55, 77, 91, 94, 97, 110
 Mimeoscope, 97
 Monitoring devices, 32, 88, 97, 99
 Multi-purpose rooms, 13, 31, 39
 Museum, 39

N

Non-parallel walls, 32, 37, 66, 68, 70,

O

Offices, 7, 13, 17, 19, 20, 24, 31, 35, 37, 39, 45, 86, 97, 99, 100, 104-107, 111
 Open stage, 53, 55, 61-63
 Organ, 32, 38-39, 70, 104-105
 Oscilloscope, 99
 Outlets, electrical, 32, 45, 53, 55, 59
 Outdoor sites, 15, 73, 75
 Overhangs, 81

P

Parking, 10, 13, 17, 19, 21, 32, 38, 60
 Philosophy, educational, 1, 7, 11
 Phonograph, 32, 34, 45, 92, 93, 94
 Piano, 32, 37-38, 45, 50, 59, 65, 70, 78, 89-90, 105, 107, 110
 Pin rail, 49-52
 Pit orchestra, 50-51, 55, 57, 59, 77
 Planning, 1, 5, 6-7, 11, 13, 34, 38-39, 41, 47, 64, 78, 82, 104, 106
 Playback systems, 93-94 (*see also* listening facilities)
 Podium, 57, 100
 Practice rooms, 7-8, 13, 17, 19, 20, 24, 30-35, 37, 40, 64, 66, 68, 78, 95, 97, 99, 104-107, 111
 Program, music education, 1, 3, 6-8, 11, 32, 45, 104
 Projection booth, 33, 38, 54, 59-60
 Projectors, 38, 90, 96
 Proscenium, 49-51, 55, 57, 71, 75, 97
 Proscenium theatre, 53-55
 Public address system, portable, 97

R

Radio, 38, 45, 90, 93, 97
 Recital hall, 8, 10, 14, 19, 20, 24, 29, 38-39, 45, 64, 67, 70, 110
 Record storage, 41
 Recording facilities, 16, 32, 38, 44, 90, 92, 110
 Reflection, light, 57, 80-81, 83-86, 110
 Reflection, sound, 32, 59, 67, 69, 70-73, 102
 Rehearsal rooms, 6-7, 10, 13, 15-17, 19-22, 24, 27-28, 32, 35-36, 38, 39-41, 45, 49, 57, 64, 65, 67-70, 78, 100-101, 105, 107, 110
 Rehearsal stage, 57
 Restrooms, *see* lavatories
 Reverberation, 28, 31, 39, 67-68, 70-71, 76, 107, 110

Risers, 17-19, 26-29, 31, 57, 80, 100-102, 110-111
 Room size, 7, 27-29, 31-32, 37, 41, 45, 67, 105-106

S

Safety, 27, 29, 52-53, 88, 100
 Scenery, 49-53, 55
 Scenic projection, 54-55
 Schedules, 11, 31, 37, 90
 Screens, 27, 31, 35, 38, 57-58, 102
 Seating, 38, 49, 59, 70-71, 75, 79, 110
 Shell, 1, 27, 51, 71, 73-75, 102
 Shelves, 33, 37, 40-41, 43, 99, 100, 101
 Sink, 45
 Sorting rack, 43, 45, 100
 Sound isolation, 10-11, 13, 31-33, 45, 64-67, 77-78, 107, 111
 Sound lock, 66, 107, 111
 Sound systems, central, 53, 97, 99, 100 (*see also* communication system)
 Speakers, *see* loudspeakers
 Specifications, amplifier, 93; piano, 89; tape recorder, 92
 Spotlights, 55
 Stage, 13, 15, 29, 31, 38-39, 45, 48-52, 55, 57, 59-60, 67, 70, 101-102
 Stagehouse, 71, 73, 102 (*see also* grid)
 Stands, music, 27, 32, 49, 79, 81, 99
 Storage, 1, 7, 13, 22, 24, 31, 33-35, 38, 41, 43, 49, 57, 66, 91, 104-107, 111
 Storage, instrument, 8, 10, 22, 27, 37, 41, 45, 50
 Storage, uniform, 8, 41, 43, 105, 110
 Stroboscope, 96
 Studios, 7-8, 16, 19, 20, 24, 31, 35-38, 45, 66-68, 104-105
 Switchboard, 49, 52, 55, 59-60, 97

T

Tachistoscope, 96
 Tape, 34, 89-92, 94
 Tape recorders, 35, 45, 90-92, 94, 97, 110
 Tape recorders, television, 95
 Teaching load formula, 104
 Telephone, 38, 53
 Television, 27, 31-32, 38, 44-45, 55, 68, 90, 95, 106, 111
 Theatre, 17, 38-39, 59-60, 77, 85
 Ticket window, *see* box office
 Toilet, *see* lavatories
 Traffic patterns, 8-11, 18, 41, 45, 107
 Transmission loss, 32, 59, 67, 111
 Trap, 49
 Tuners, 45, 94, 96, 110
 Tuning room, 22

V

Vending machines, 46
 Ventilation, 31, 41, 47, 51, 60, 65, 77, 106-107, 111
 Visiting school plants, 3, 8, 11, 106

W

Windows, 32, 35, 41, 51, 65, 77-78, 80-82, 85, 107
 Workrooms, 17, 24, 37-38, 43, 45-46, 50, 104-105, 107, 111