

R E P O R T R E S U M E S

ED 015 784

24

FS 000 335

THRESHOLD BY IDENTIFICATION OF PICTURES (TIP) TEST AND
DISCRIMINATION BY IDENTIFICATION OF PICTURES (DIP) TEST.

BY- SIEGENTHALER, BRUCE M. HASPIEL, GEORGE S.

PENNSYLVANIA STATE UNIV., UNIVERSITY PARK

REPORT NUMBER CRF-2372-1

REPORT NUMBER BR-5-1064-1

CONTRACT OEC-5-10-003

EDRS PRICE MF-\$0.50 HC-\$3.36 82P.

DESCRIPTORS- *TESTS, *AUDITORY VISUAL TESTS, AUDITORY TESTS,
*AUDIOMETRIC TESTS, AUDITORY DISCRIMINATION, AUDITORY
PERCEPTION, EARLY CHILDHOOD, STANDARDIZED TESTS, TIP, DIP,

THIS DOCUMENT COMPRISES 2 HEARING ABILITY TESTS FOR 3-
TO 8-YEAR-OLD CHILDREN. THEIR ADMINISTRATION REQUIRES A
SPEECH AUDIOMETER. TEST NORMS WERE ESTABLISHED FOR RECORDED
MATERIALS IN A SOUND FIELD. BOTH TESTS USE COLORED PICTURE
CARDS, AND IT IS ESSENTIAL THAT THE CHILD BE ABLE TO IDENTIFY
ALL ITEMS SHOWN. THE THRESHOLD BY IDENTIFICATION OF PICTURES
(TIP) TEST DETERMINES THE SPEECH RECEPTION THRESHOLD WITH AN
ERROR OF 3 DB. THE DISCRIMINATION BY IDENTIFICATION OF
PICTURES (DIP) TEST USED 48 PAIRED ITEMS DIFFERING IN INITIAL
CONSONANTS AND MAY BE USED TO DETERMINE SPEECH DISCRIMINATION
AT LEVELS FROM 9 TO 19 DB ABOVE THE SPEECH RECEPTION
THRESHOLD. INSTRUCTIONS FOR THE ADMINISTRATION, SCORING, AND
INTERPRETATION OF THE TESTS ARE GIVEN. THE PICTURE CARDS ARE
INCLUDED, AND SCORING SHEETS FOR BOTH TESTS ACCOMPANY THE
DOCUMENT. (DR)

PS 000335

U.S. DEPARTMENT OF HEALTH, EDUCATION & WELFARE
OFFICE OF EDUCATION

ED015784

THIS DOCUMENT HAS BEEN REPRODUCED EXACTLY AS RECEIVED FROM THE PERSON OR ORGANIZATION ORIGINATING IT. POINTS OF VIEW OR OPINIONS STATED DO NOT NECESSARILY REPRESENT OFFICIAL OFFICE OF EDUCATION POSITION OR POLICY.

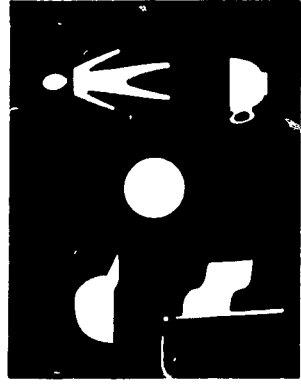

**T·I·P THRESHOLD
BY IDENTIFICATION OF PICTURES**

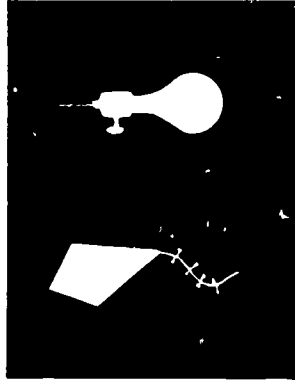

**D·I·P DISCRIMINATION
BY IDENTIFICATION OF PICTURES**

THE PENNSYLVANIA
STATE UNIVERSITY

SPEECH AND HEARING CLINIC

The development of these test materials was supported through the Cooperative Research Program of the Office of Education, U.S. Department of Health, Education and Welfare (Project No. 2372, OE-5-10-003).

BRUCE M. SIEGENTHALER, Ph.D. GEORGE S. HASPIEL, Ph.D.

BR-5-1064
PA 24

PS 000335

TABLE OF CONTENTS

	Page
INTRODUCTION.....	III
THRESHOLD BY IDENTIFICATION OF PICTURES (TIP) TEST.....	IV
Description of TIP Test.....	IV
Instructions for Administering TIP Test.....	V
TIP Scoring, Tabular Method.....	VI
TIP Scoring, Graphic Method.....	VI
Interpretation of Scores.....	VII
TIP SCORING SHEET.....	X
THRESHOLDS FOR AGE GROUPS ON TIP TEST.....	XI
TIP TEST CARDS.....	
TIP A Practice	
TIP A.....1-5	
TIP B Practice	
TIP B.....1-5	
DISCRIMINATION BY IDENTIFICATION OF PICTURES (DIP) TEST.....	XII
Description of DIP Test.....	XII
Instructions for Administering DIP Test.....	XIII
DIP Scoring.....	XIV
Interpretation of Scores.....	XIV
DIP Sample Scoring Sheet.....	XVI
DIP Test Scoring Table.....	XVII
Scores for Age Groups on DIP Test.....	XVIII
DIP TEST CARDS.....	
DIP A, B, C, D, Practice	
DIP V..... 1-5	
DIP I..... 6-9	
DIP P..... 10-17	
DIP VI..... 18-25	
DIP VP..... 26-29	
DIP IP..... 30-37	
DIP VIP..... 38-48	

THRESHOLD BY IDENTIFICATION OF PICTURES (TIP) TEST
AND
DISCRIMINATION BY IDENTIFICATION OF PICTURES (DIP) TEST

Introduction

The TIP and DIP tests are measures of speech hearing ability constructed and validated for use with pre-school and school age children. The tests may be administered in the usual audiologic facility, using equipment and procedures common to threshold and discrimination tests employing verbal materials.

The child should sit at a previously determined point relative to the sound source at a small table appropriate for his size. When using live voice procedures an assistant to the tester may sit beside the child, turning the test picture pages, and if necessary indicating to the tester when the next item may be presented. Either the assistant or tester may mark through the incorrectly identified item on the scoring sheet for a permanent record, or keep a tally using a hand counter.

These tests may be administered using live voice, or recorded materials can be prepared. Tests may be administered in a sound field, or through earphones, either monaural or binaural.

The original research was done using recorded materials in a sound field. The accompanying norms are for this condition. Live voice presentation has the advantage of greater flexibility for meeting the child's needs and has no poorer reliability than recorded presentation, using skillful

testers and a speech audiometer. Live voice produces two dB more acute threshold measurements than recorded. Binaural earphones (if the ears are equal) give three dB more acute threshold measurements than monaural earphone. Field testing (binaural) gives three dB more measured acuity than binaural earphones. These values should be taken into account when interpreting a TIP test threshold. No similar values are available for intelligibility testing or for discrimination testing as with the DIP test.

Although only very familiar words have been included, it is possible that some hearing impaired children will be unfamiliar with some of the items. Before beginning either of the tests it is advisable to determine if there are unfamiliar items; if so, they should be explained and the names taught to the child. Usually the parent can indicate items unfamiliar to the child.

Threshold by Identification of Pictures (TIP) Test

Description of TIP Test

The TIP test consists of two Forms (Form A and Form B) of multiple choice items for obtaining speech reception threshold. Each form has a practice card and five test cards. There are five items on each card. The items are monosyllabic familiar word-pictures which are called to the child in a predetermined order following the usual speech reception test procedures. A child responds by pointing to the picture of the word he thought he heard.

Instructions for Administering TIP Test

1. Check child's familiarity with test items.
2. Explain test procedure face-to-face, or use speech audiometer.
3. Use TIP Scoring Sheet for lists of call words for each TIP picture card.
4. Explore for approximate speech reception threshold using practice card TIP A.
 - a. Monitor carrier phrase "Point to the . . ." and the test items at VU O.
 - b. Call first Practice item at a level well above expected threshold.
 - c. Continue calling Practice items, attenuating 10 dB after each item until child consistently fails to respond correctly.
 - d. Re-use Practice items on the same card as necessary.
 - e. Add 10 dB to last correct-response level on Practice items, and write this beginning level value on the scoring sheet in the top space under audiometer setting. Write the presentation levels for the other four words in each column in 5 dB decreasing steps in the spaces provided.
5. Present first item on card TIP A-1 at the beginning level as noted on the top line under audiometer setting, and observe child's pointing response.
6. Call second item in the column at a level 5 dB less than the first item (as previously noted under audiometer setting). Observe response, and call third item 5 dB lower than the preceding item. Continue in 5 dB attenuation steps until all five words for a card are called. Draw a line through items not identified (pointed to) correctly. Call each item only once; even though the child does not respond correctly go directly to the next item at a 5 dB lower level. (Only exception is gross extenuating circumstance).
7. Turn to card TIP A-2 and give the first item at the same level as the first item on card TIP A-1. Use same procedure as before for remaining items on card TIP-2 (i.e., attenuating 5 dB after each item).
8. Present cards A-3, A-4 and A-5 to complete TIP Form A. Give the first item on each card at the beginning level, and attenuating 5 dB per item for a given picture card.

9. It is necessary that the first item of every card be identified correctly and the last item be failed if the tabular method of scoring is to be employed. In some cases, however, it will not be possible to achieve this and the graphic method may be used. If the beginning level was not estimated correctly for the first card, the beginning level may be adjusted for subsequent cards. Retest on first card after the other four cards have been used.
10. Tell the child to relax until it is time for the next test.
11. TIP Form B is administered the same as TIP Form A, use the Form B cards and call words.
12. Individual cards from one TIP Form are not interchangeable with individual cards from the other Form.

TIP Scoring, Tabular Method (done for each form separately)

1. Count number of items correctly identified across all cards for a TIP Form at each audiometer setting, and write number in space to the right on the Scoring Sheet under NUMBER CORRECT for each level separately. Total the number of items identified correctly at all settings on all cards, and write the number in the space TOTAL CORRECT. (A tally counter may be used if the tester is certain the beginning level will produce all correct responses.)
2. Subtract TOTAL CORRECT from speech audiometer attenuator dB setting for beginning level of audiometer setting.
3. Add 2.5 dB correction factor to obtain speech reception threshold (to compensate for the 5 dB attenuation steps used.)
4. The THRESHOLD may be recorded on the scoring sheet in the space provided.
5. Thresholds may be noted in dB re .0002 dy/cm², or as hearing levels. (See below.)

TIP Scoring, Graphic Method (done for each form separately)

1. Count the number of items correctly identified across all cards for a TIP Form at each

presentation level, and write number in space to the right on the Scoring Sheet under NUMBER CORRECT for each presentation level separately.

2. Write dB presentation levels at bottom of SCORING GRID on Scoring Sheet for a series of five levels putting lowest dB level to the left and using one vertical line per 5 dB step. (The grid provides space for repeated test presentation.)
3. For each dB presentation level mark number correct on the GRID.
4. Draw a smooth curve of best fit, using visual estimates (projecting the curve to five correct and to none correct) according to expected articulation curve shown on the TIP Scoring Sheet GRID and specified as:
change from 12% to 75% correct over a range of 14.5 dB
0% correct at 12 dB below dB level for 12% correct
90% correct at five dB above dB level for 75% correct
100% correct at 15 dB above dB level for 75% correct

(This curve may be made into template form for ease of drawing.)
5. Observe intersection of 50% correct and the curve of best fit.
6. Project this intersection downward to the dB presentation level scale and note dB level (estimate to the nearest one-half decibel). This is the speech reception threshold.
7. The THRESHOLD may be recorded on the scoring sheet in the space provided.
8. Thresholds may be noted in dB re .0002 dy/cm², or as hearing levels. (See below.)

Interpretation of Scores

Refer to the chart THRESHOLDS FOR AGE GROUPS ON TIP TEST, which shows normal TIP thresholds using recorded materials in a sound field re .0002 dy/cm². If your speech audiometer is

calibrated in dB re .0002dy/cm² and you used recorded materials in a sound field, compute the child's speech reception threshold deviation from normal (his hearing level) by subtracting the appropriate dB correction factor (obtained on the left of the chart) for his age and for TIP test Form from the audiometer panel setting.

If your speech audiometer has other than an SPL calibration or if you use earphones or live voice testing, do not expect that your dB panel settings will produce threshold for the TIP test as shown on the chart **THRESHOLDS FOR AGE GROUPS ON TIP TEST** because of the effects of age and of test procedure. Calibrate your audiometer. When calibrating your speech audiometer the obtained normal SRT will be influenced by the test situation, in addition to the age of the children and TIP Form used. Live voice testing gives measured thresholds two dB lower in intensity than recorded voice; two earphone listening (assuming equal ears) gives three dB better measured acuity than one earphone listening; field testing gives three dB better measured acuity than binaural earphone listening.

Do a real-ear calibration, using at least ten children with known normal hearing, and all within three months of the same age. Obtain the average (median) speech audiometer panel setting in dB for their thresholds, and write this value to the right of the chart **THRESHOLDS FOR AGE GROUPS ON TIP TEST** for the test Form used and at the level of intersection of their age group line and the

normal curve for the TIP test Form used. Interpolate dB levels when necessary. The appropriate one dB steps should be written along the right margin of the chart to complete the calibration corrections (larger dB values toward the top of the chart and smaller dB values toward the bottom).

As subsequent children are tested, obtain SRT and enter the chart at the bottom for the child's age, read up to the test Form used, and read right to find the appropriate correction factor. Subtract this value from the audiometer setting for threshold to obtain his hearing level (threshold deviation from normal) for his age and for test Form used.

Standard error of estimate for TIP thresholds is ± 3 dB. That is, 2/3 of the retest thresholds will be expected to fall within three decibels of initial test thresholds.

THRESHOLD BY IDENTIFICATION OF PICTURES (TIP) SCORING SHEET

NAME _____ SEX _____ DATE _____ EXAMINER _____
 ADDRESS _____ BIRTHDATE _____

Field _____ Earphones _____ Test Validity _____ Remarks _____

FORM A
Practice A

audiometer setting _____

	A-1	A-2	A-3	A-4	A-5	NUMBER CORRECT
chair	hands	house	horse	clock	eyes	_____
shoe	dog	flag	ball	mouse	train	_____
chair	truck	dress	cat	drum	milk	_____
bread	stove	bus	fish	cup	eyes	_____
cap	hands	kite	ball	clock	spoon	_____

THRESHOLD _____

TOTAL CORRECT _____

Right _____ dB

FORM B
Practice B

audiometer setting _____

	B-1	B-2	B-3	B-4	B-5	NUMBER CORRECT
shoe	door	bed	lamb	skates	tree	_____
chair	pie	boat	corn	clown	knife	_____
car	cow	hand	top	comb	doll	_____
swing	socks	gum	lamb	gun	tree	_____
dog	pie	bed	frog	clown	blocks	_____

Left _____ dB

Bin. _____ dB

TOTAL CORRECT _____

SCORING GRID

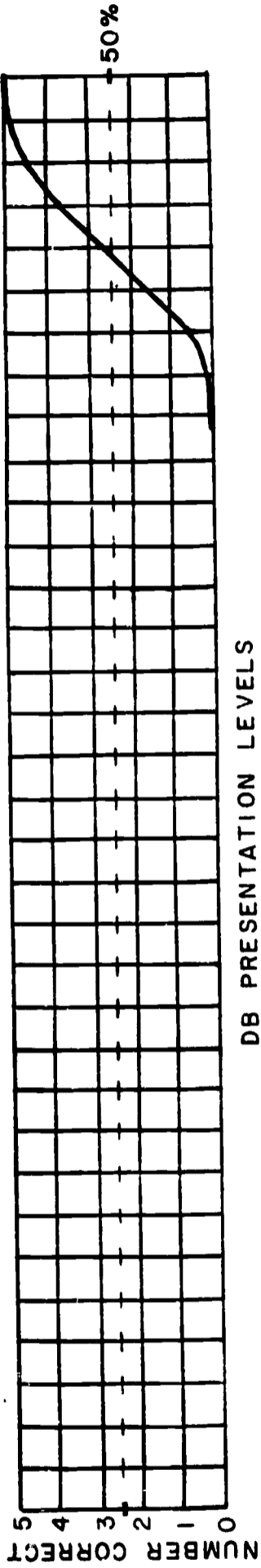

DB PRESENTATION LEVELS

Figure 1. TIP test protocol and scoring s X

THRESHOLDS FOR AGE GROUPS ON TIP TEST

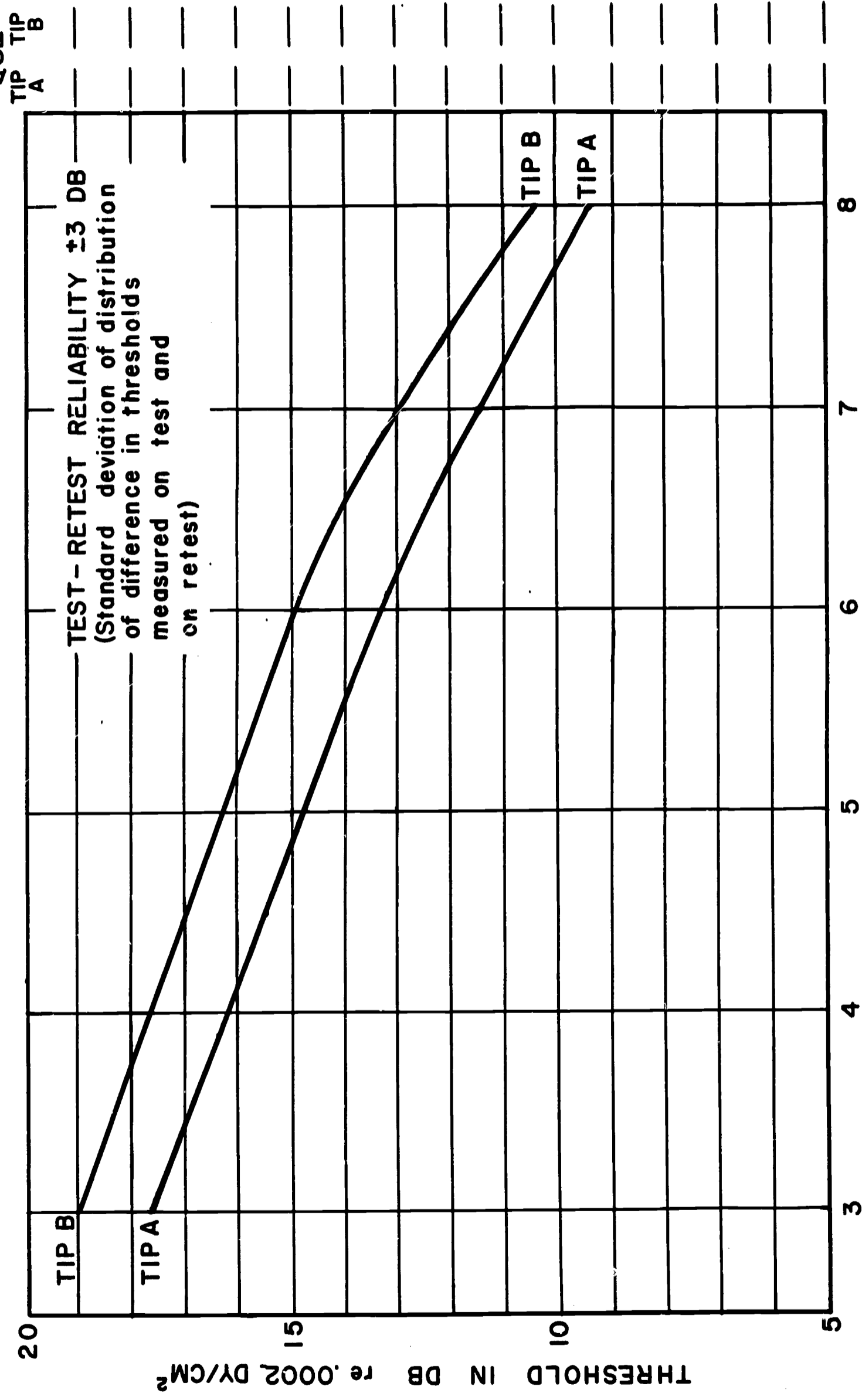

AUDIOMETER
CORRECTION
FOR AGE
TIP A
TIP B



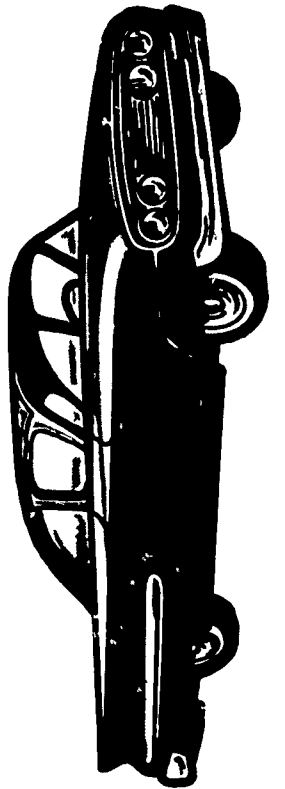
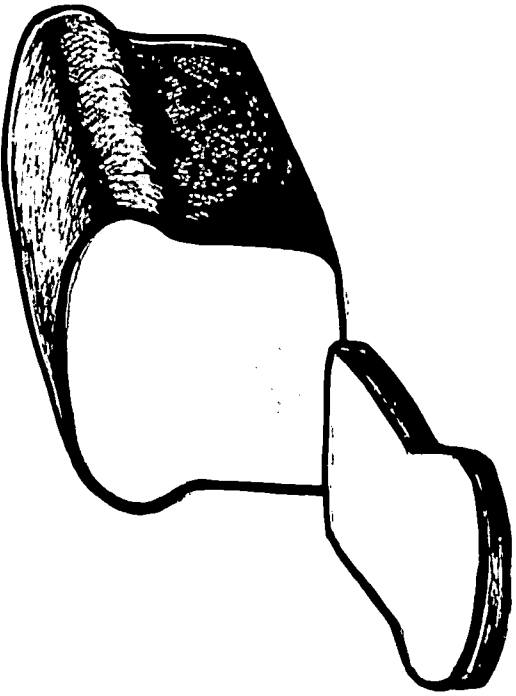
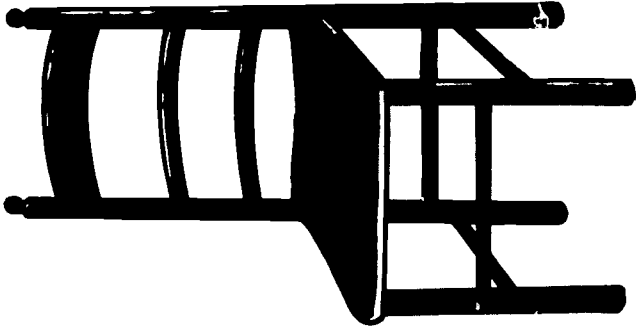
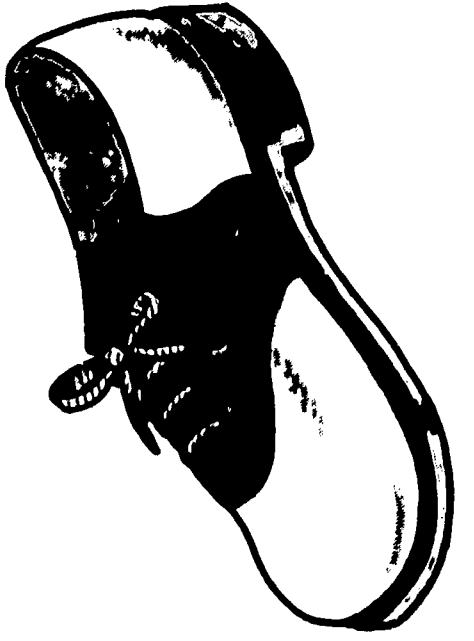
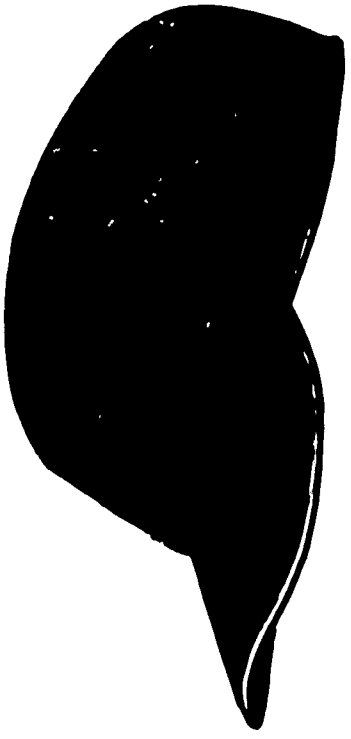

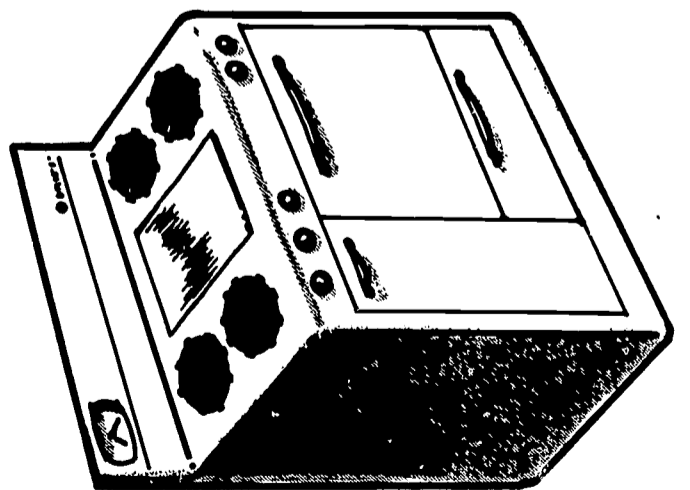
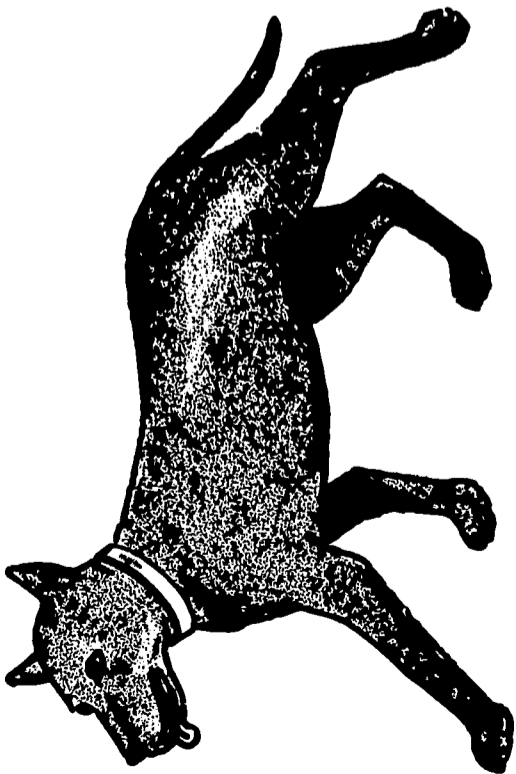
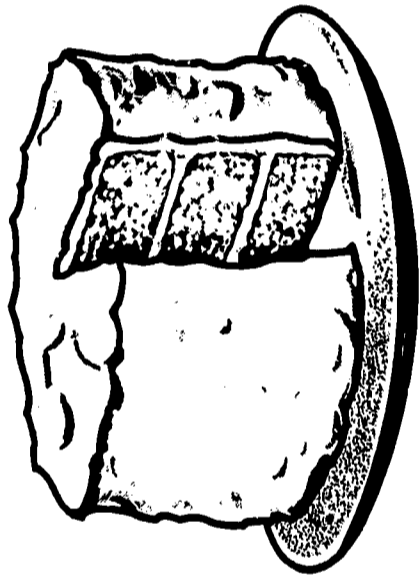
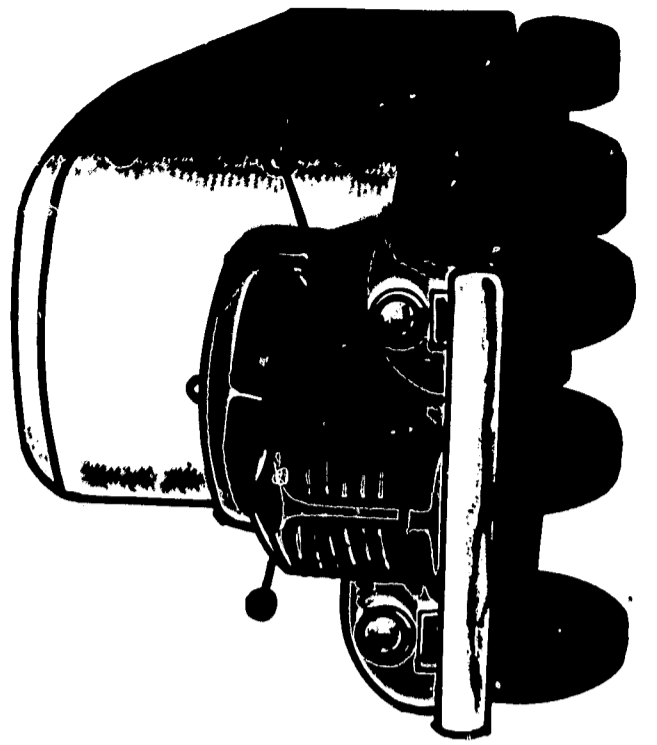
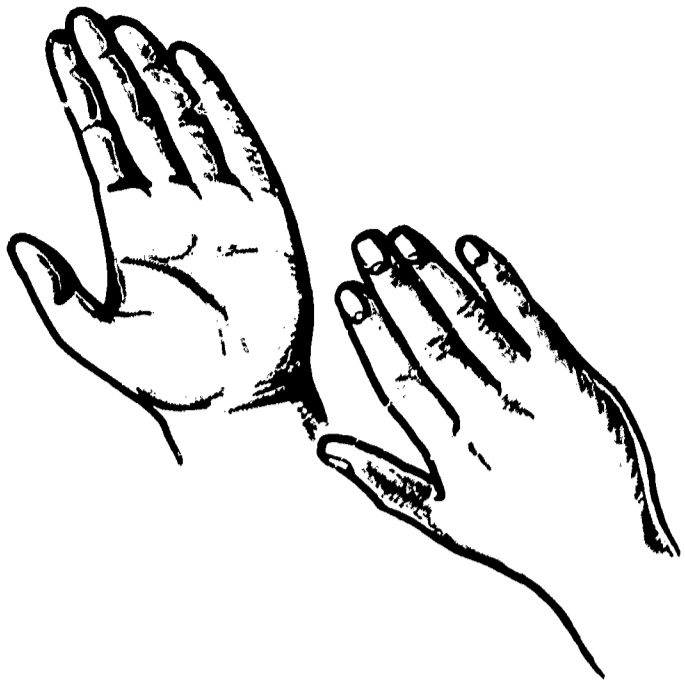

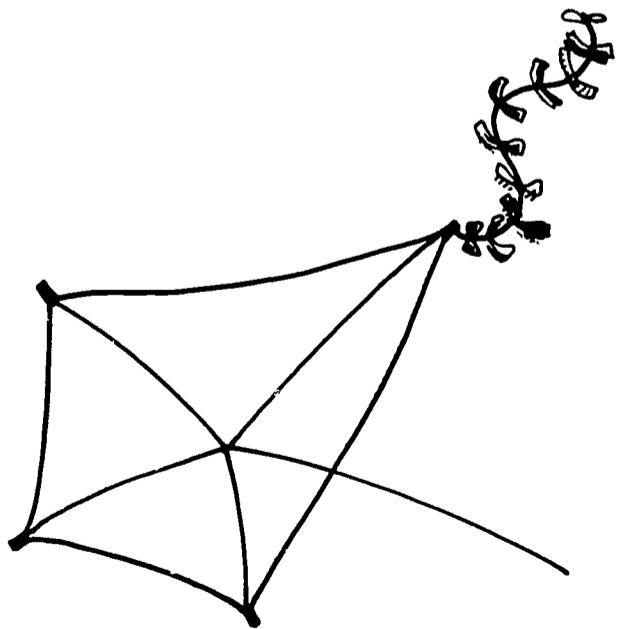
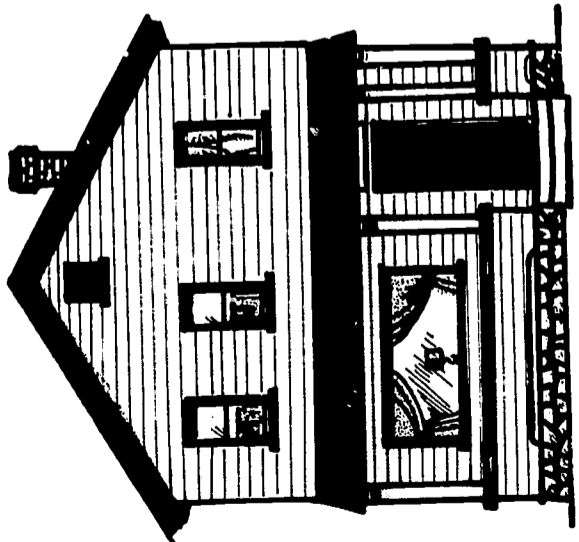
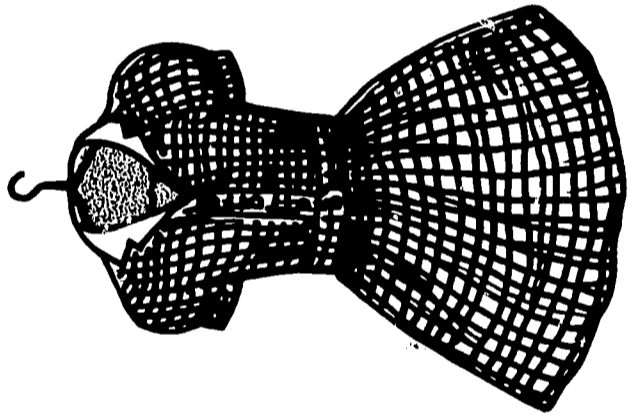
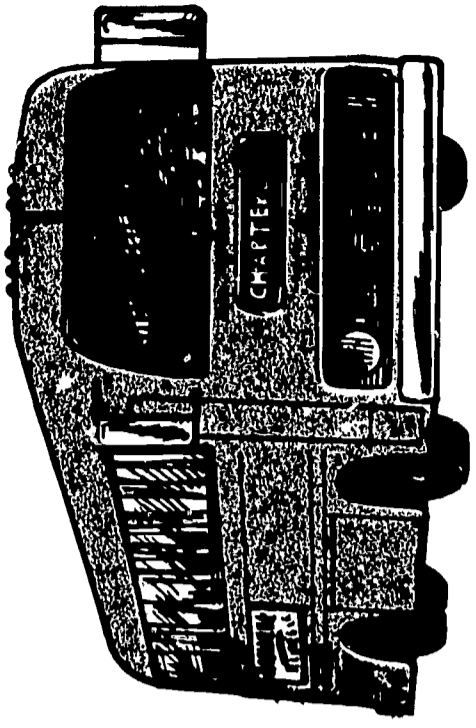

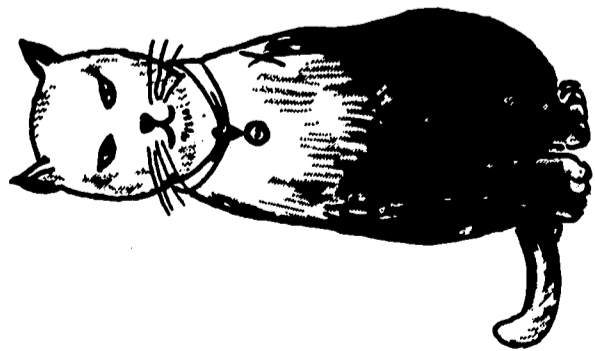
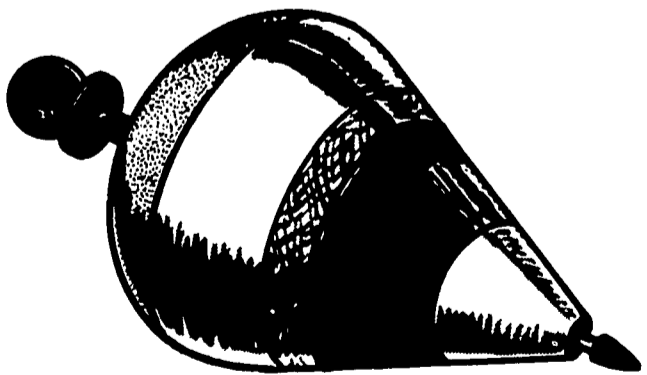
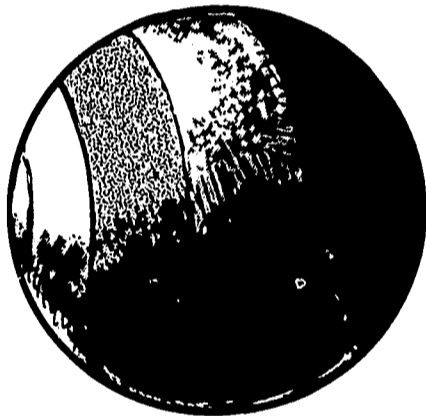

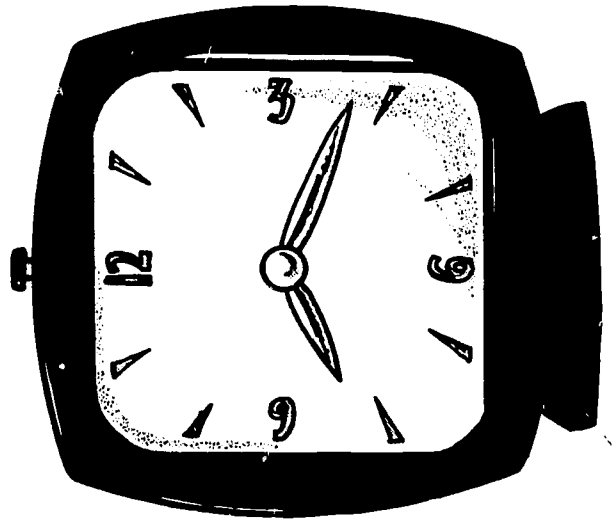
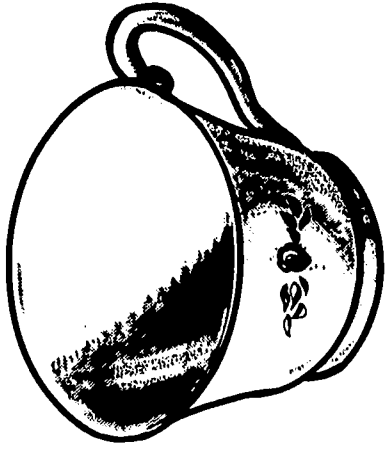
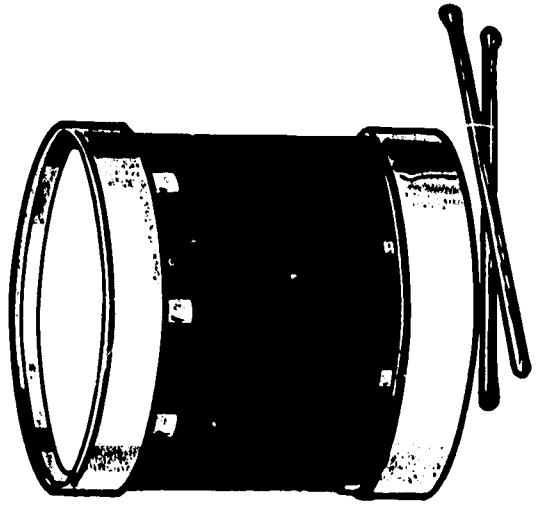
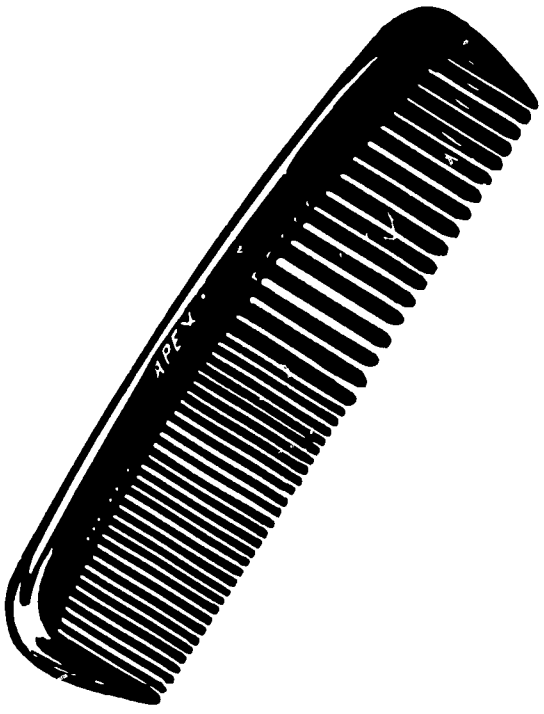

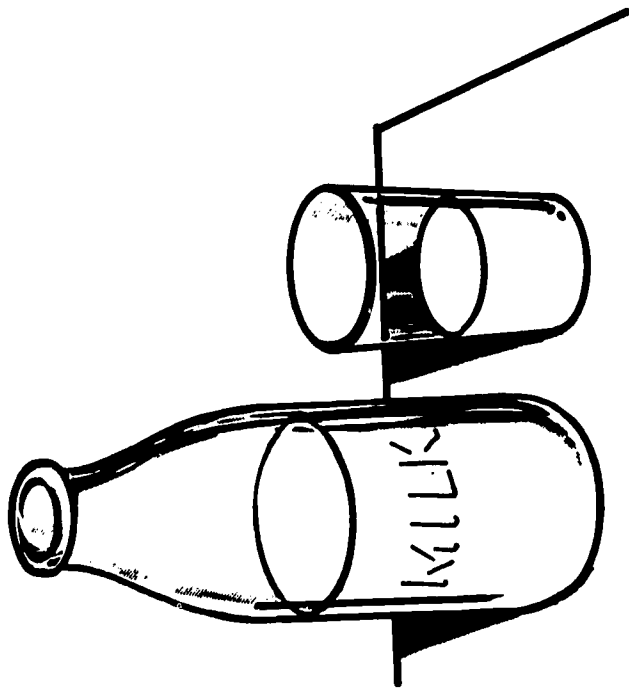
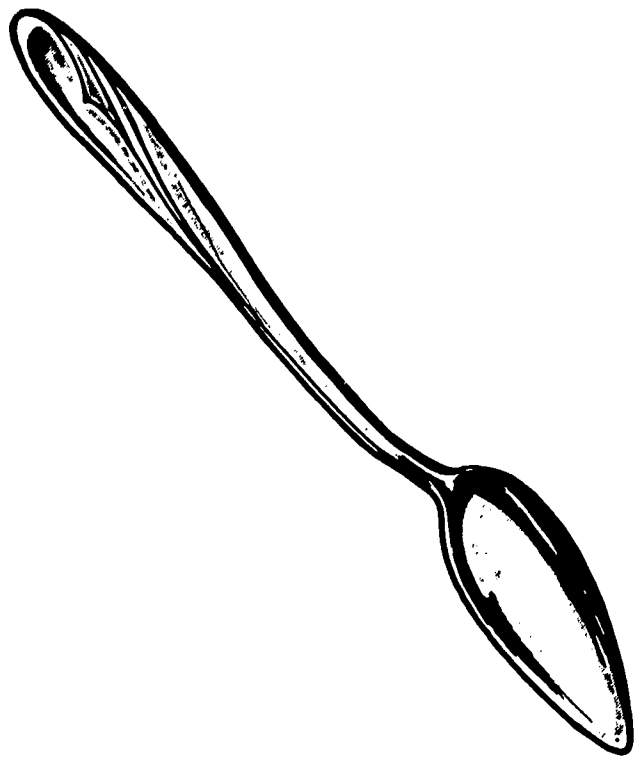
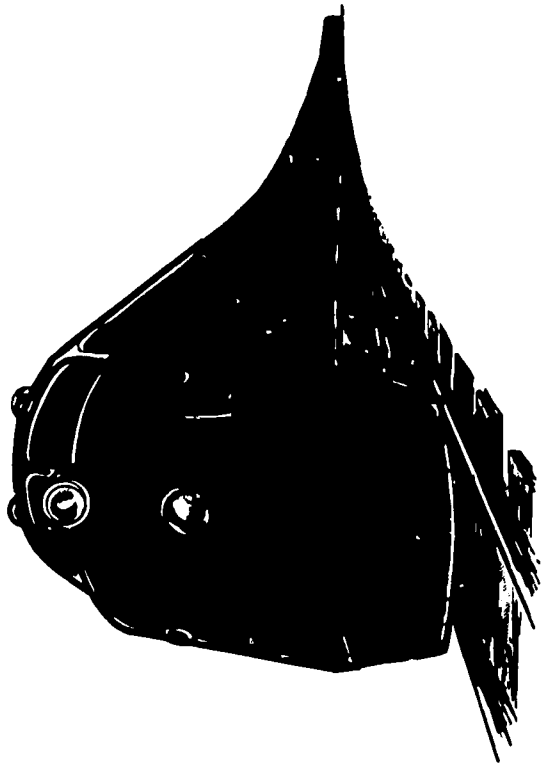

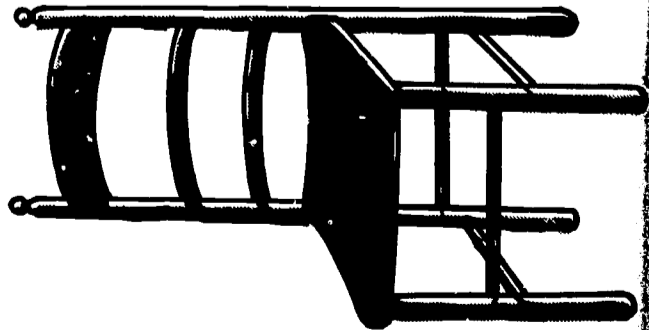
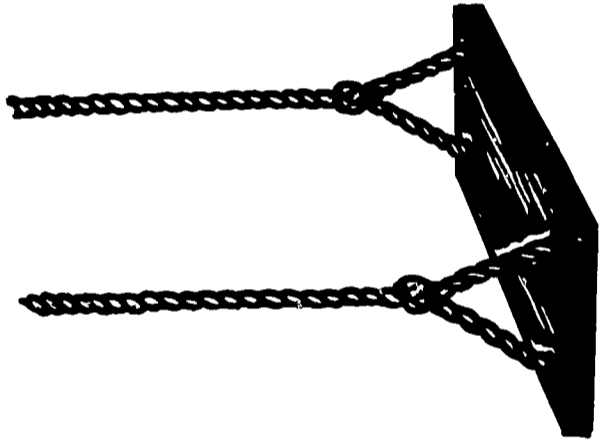
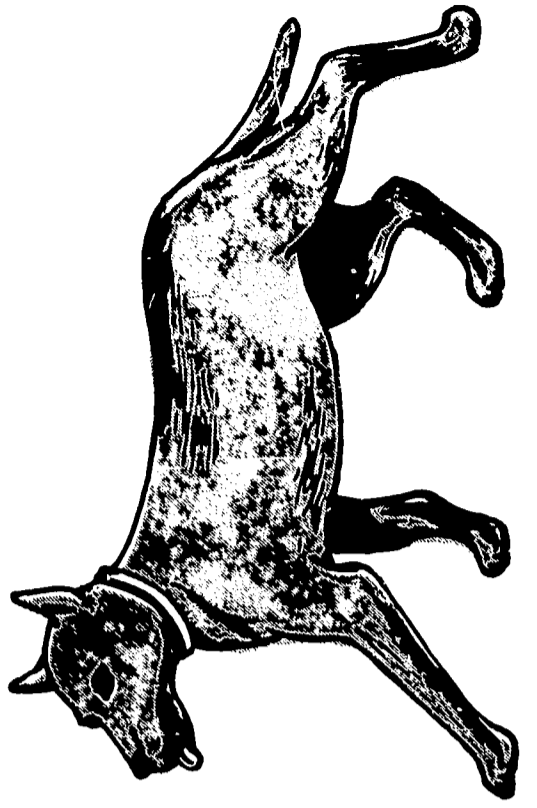
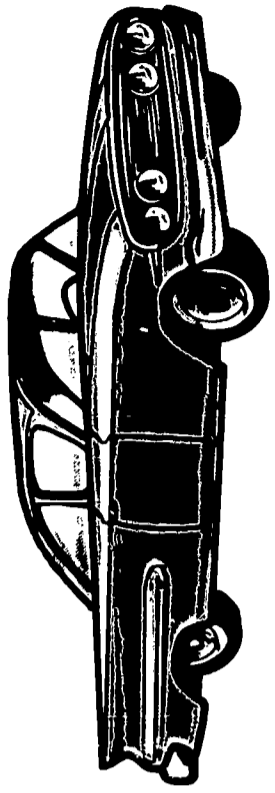

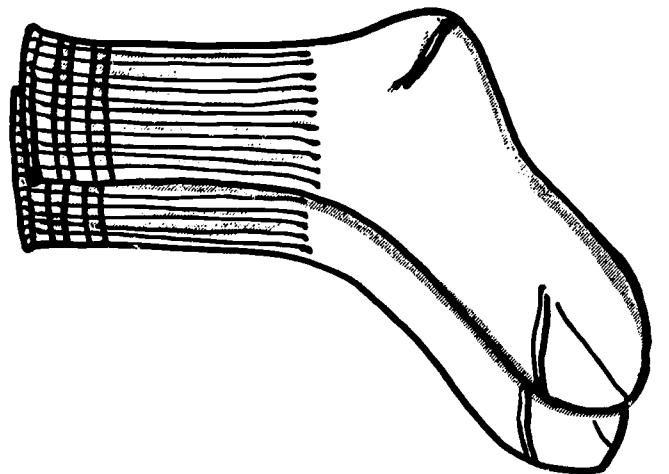
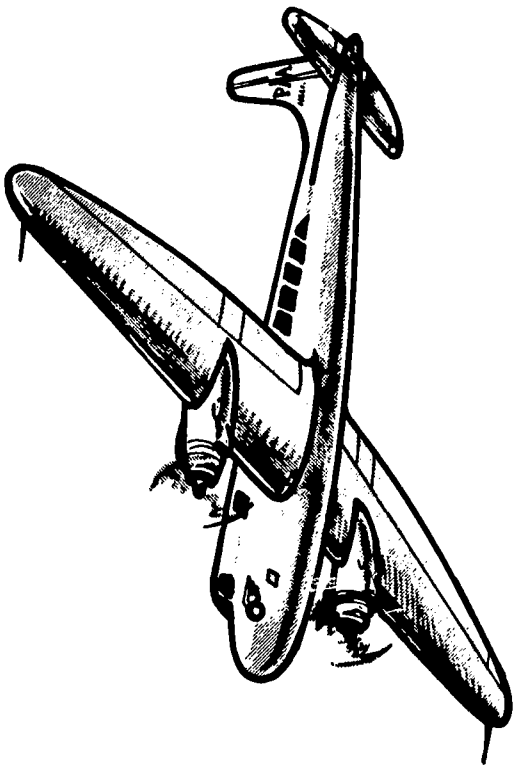
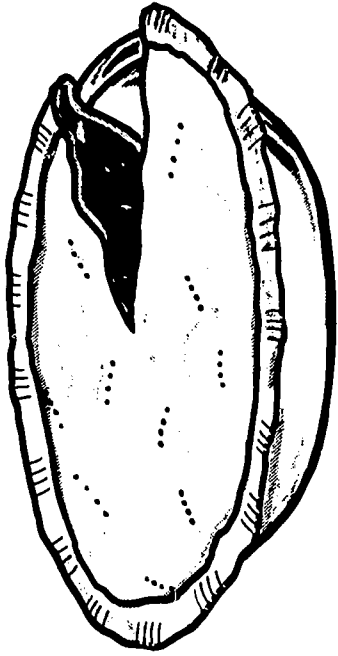
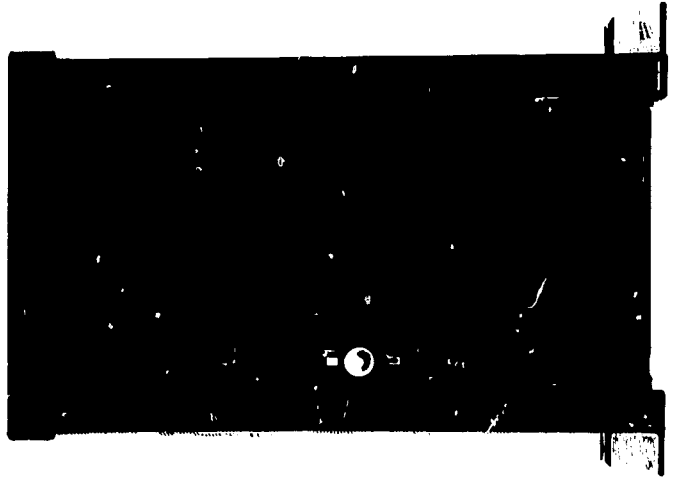
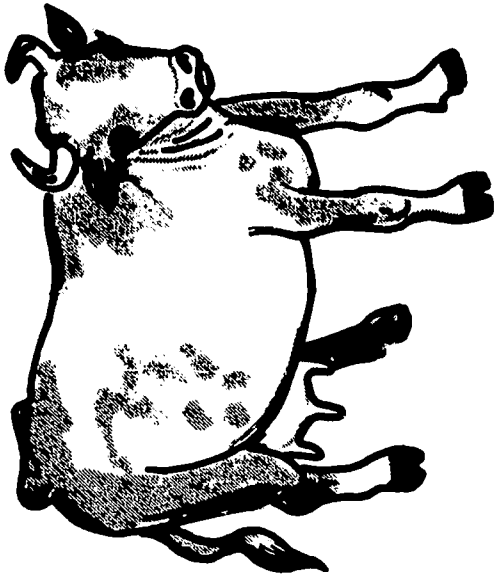

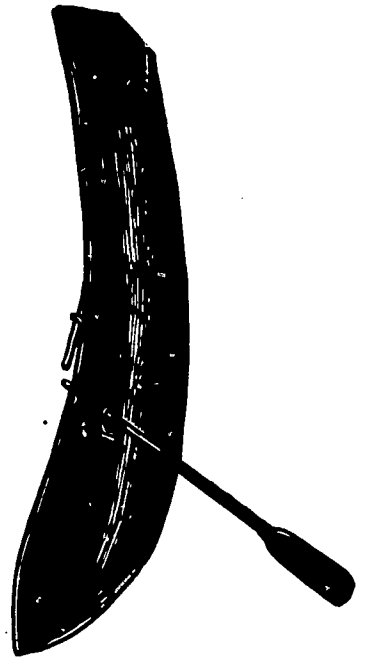
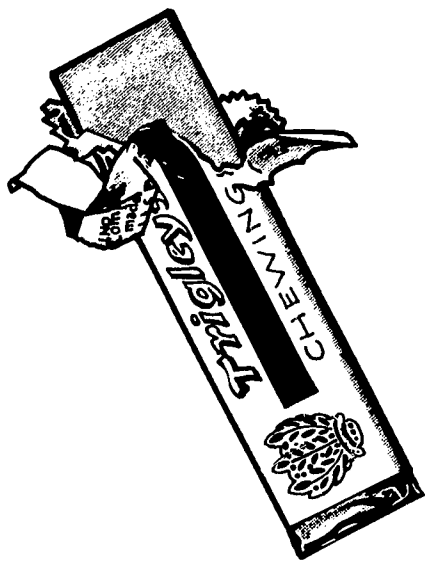
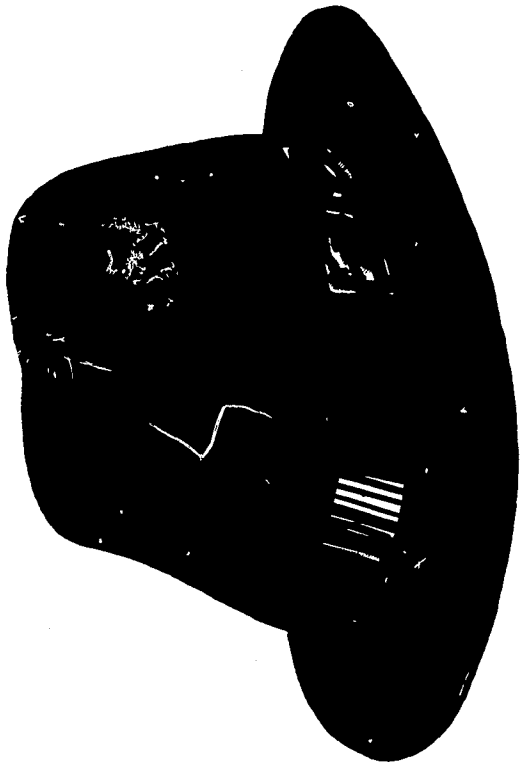
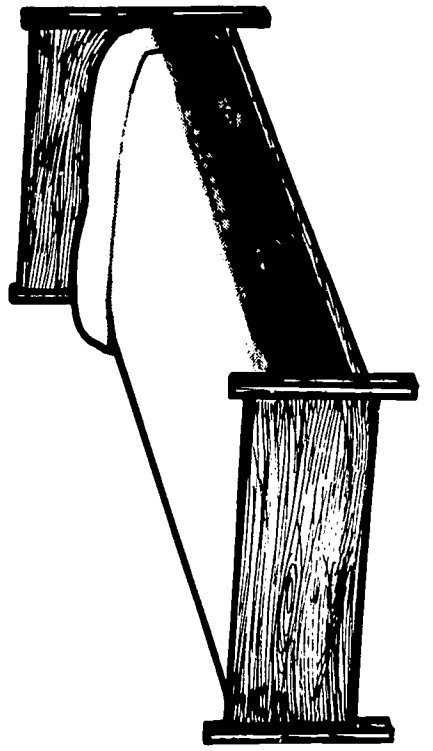
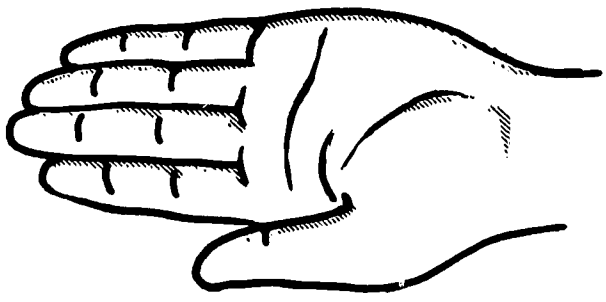

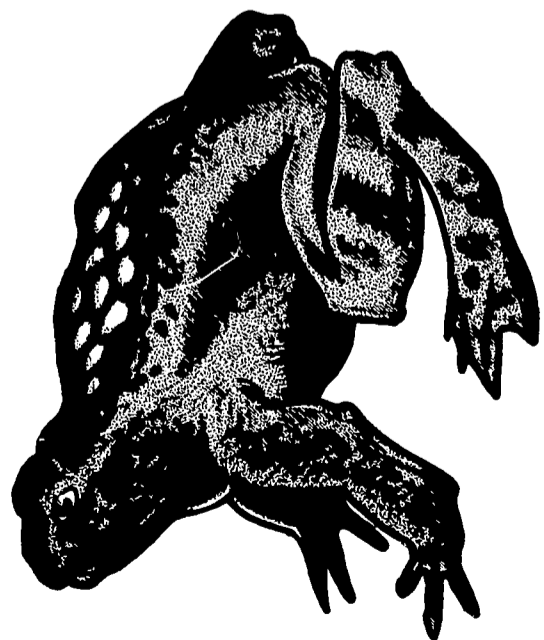
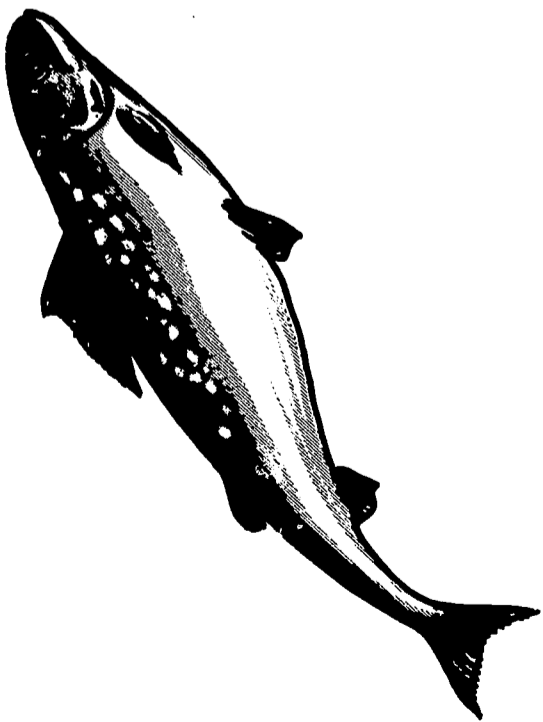
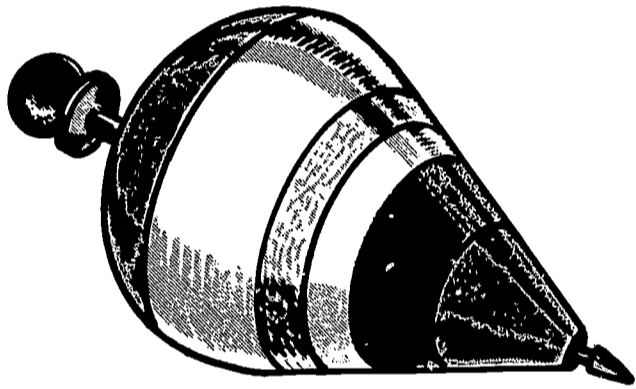
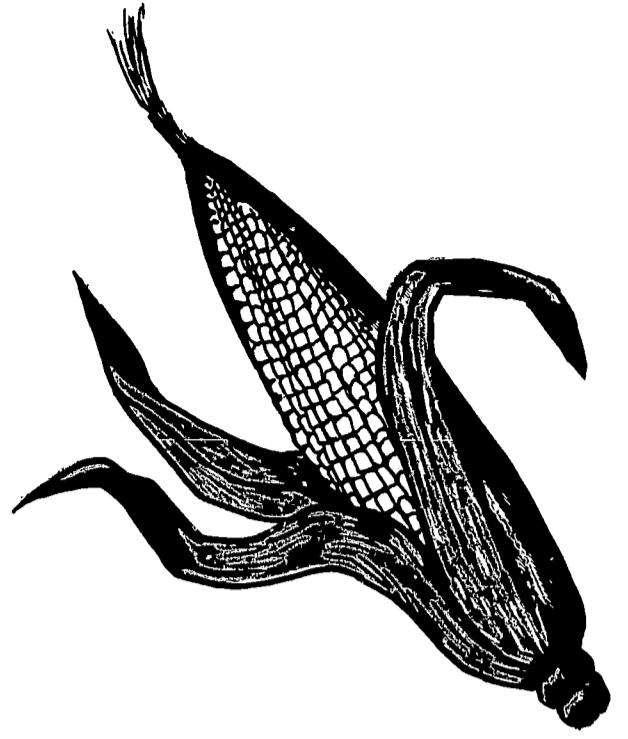
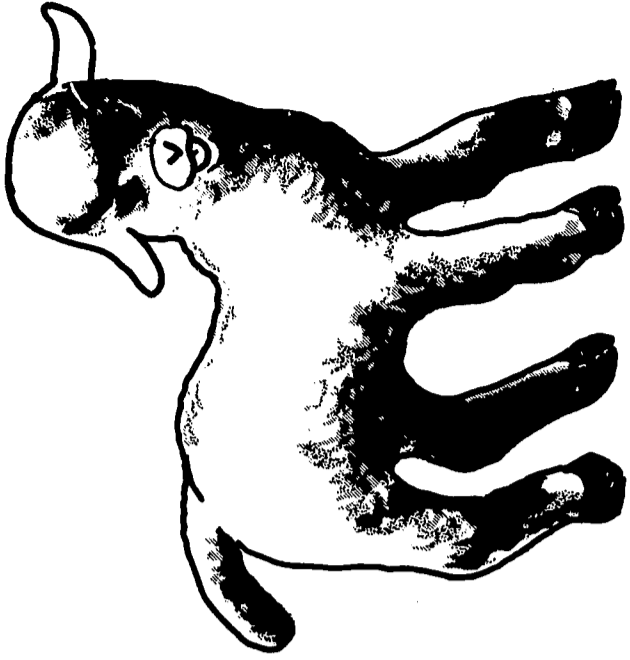

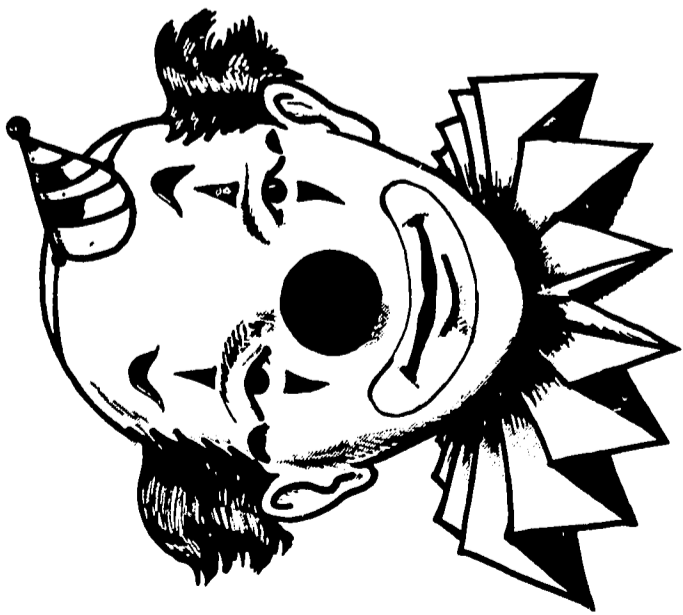
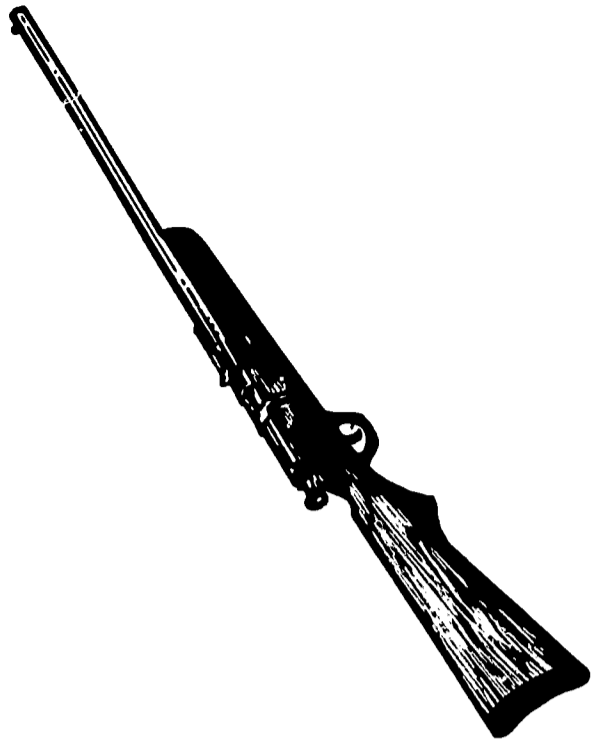
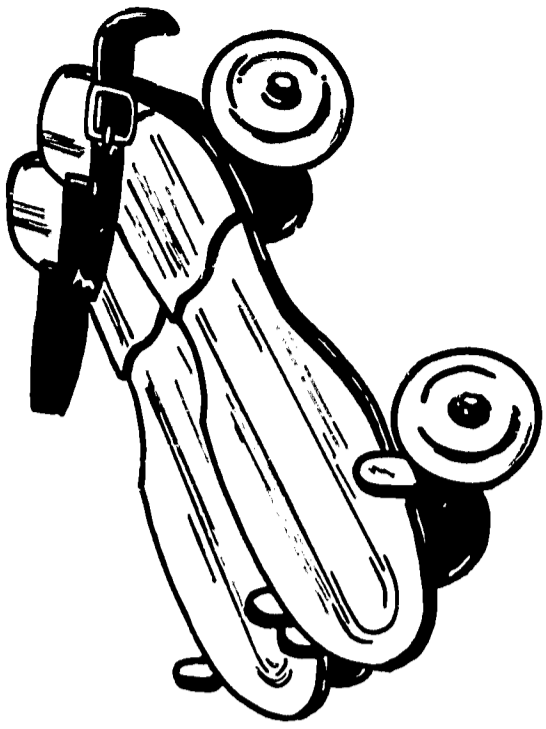

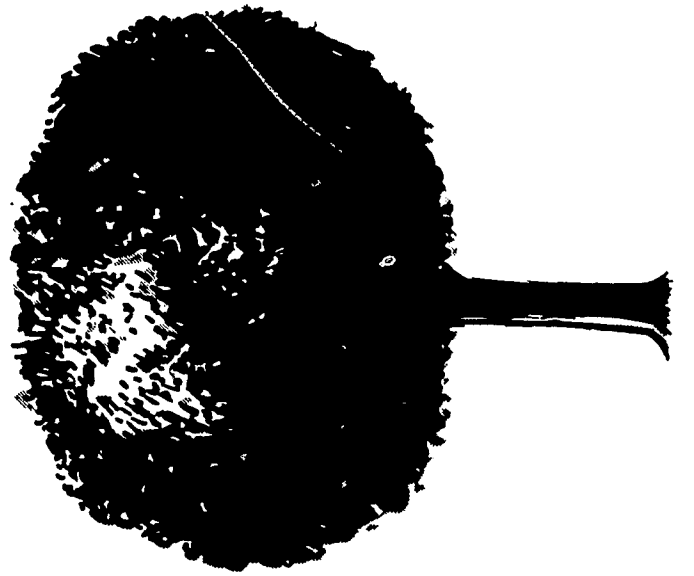
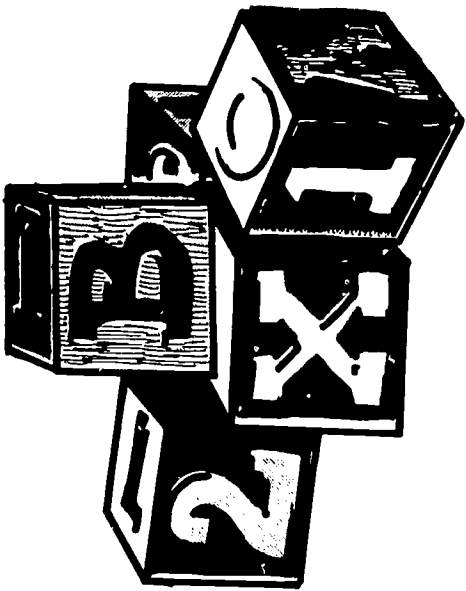

Discrimination by Identification of Pictures (DIP) Test

Description of DIP Test

The DIP test is composed of 48 paired monosyllabic items of which the initial consonants are different in voicing, influence, pressure pattern or combinations of these acoustic factors. The words used are familiar, and together with the pictures were validated for familiarity and recognition with a group of hearing impaired pre-school children.

Three Forms of the DIP test have been prepared using the pool of 48 pairs of pictures and words.

Each of the Forms contains the following distribution of paired items differing in their initial consonants:

5	voicing (DIP pages VI-5)
4	influence (DIP pages I 1-5)
8	pressure pattern (DIP pages P 10-18)
8	voicing and influence (DIP pages VI 18-25)
4	voicing and pressure pattern (DIP pages VP 26-29)
8	influence and pressure pattern (DIP pages IP 30-37)
11	voicing, influence, and pressure pattern (DIP pages VIP 38-48)

The DIP test cards are used in the same order for all three forms.

The DIP test can be used for several audiological purposes including the measuring of speech discrimination ability at most-comfortable listening level, conversational level, or other appropriate points on the intensity scale. Data have been determined for normal hearing young children at SRT +

0 dB, SRT + 5 dB, and at SRT + 10 dB (speech reception thresholds obtained with the TIP test).

Instructions for Administering DIP Test

1. Check child's familiarity with test materials.
2. Orient child to test procedure, either face-to-face or over speech audiometer.
3. Select appropriate speech audiometer output level, either field or earphones, monaural or binaural and DIP Form. (All three DIP Forms are equivalent, and each has the same manner of presentation.)
4. Monitor voice at VU O for carrier phrase "Point to the . . ." and for DIP words.
5. Call first practice item, from DIP Scoring Sheet, which contains Practice items, and wait for response.
6. Child indicates item by pointing.
7. Call additional practice items, reusing them if necessary until child is familiar with the test procedure, and turning page after each item to use the four practice items.
8. Call first DIP test item, observe response, turn page, and call next item (at same intensity level).
9. Draw line through test word on DIP Scoring Sheet if incorrectly identified. (An alternative procedure is to use a hand tally counter, but this does not give a permanent record of specific items missed.)
10. Proceed in like manner to call remaining test items, without changing presentation level to complete all 48 items on the Form.
11. Call each item only once. Do not repeat unless gross extenuating circumstances require it; then repeat the item immediately.

12. When the DIP list is completed, tell the child to relax until the next test.

DIP Scoring

1. Count the number of items missed to find Error Score, and record on DIP Scoring Sheet.
2. Multiply error score by 2.1 to determine Error Per Cent.
3. Subtract Error Per Cent from 100% to obtain DIP Per Cent.

(According to this method, a perfect discrimination score would be 100.8%. For most purposes this discrepancy can be ignored. The DIP per cent may be read from the accompanying DIP Scoring Table which gives the DIP per cent for error scores, rounding to the nearest whole per cent.)

If an intelligibility curve is to be drawn showing DIP test score as a function of presentation level, the slope of the function is 1.8 test items per dB change in presentation level over the range SRT + 0 dB through SRT + 10 dB.

Interpretation of Scores

Refer to normative data on SCORES FOR AGE GROUPS ON DIP TEST chart for comparison of child's score to normal for his age group at the presentation level used. These normative values were obtained with recorded voice, field presentation, on normal hearing children. Data are not yet

available for older or younger children or for other manners of test administration. The present best estimate is that there is little change in DIP scores after eight years of age.

Because 50% of the items in the DIP test could be guessed by chance, the range of critical scores is from 50% to 100%; a 50% or less score is a poor score. It is important that the scores be described as DIP Scores because of the possible confusion with other tests based on different principles and requiring different forms of response.

The standard error of estimate for the DIP Score is ± 5 items. That is, 2/3 of the retest scores will be expected to fall within five items (approximately 10%) of the test score.

Discrimination by Identification of Pictures (DIP)
Scoring Sheet

NAME _____ AGE _____ DATE _____

Card	DIP Form 1	100% %	%	DIP Form 2	100% %	%	DIP Form 3	100% %	%
Practice A	dog	minus Error Per Cent : DIP Per Cent	%	cat	minus Error Per Cent : DIP Per Cent	%	dog	minus Error Per Cent : DIP Per Cent	%
B	chair			boat			chair		
C	kite			kite			kite		
D	coat			kite			coat		
DIP V-1	bear	minus Error Per Cent : DIP Per Cent	%	pear	minus Error Per Cent : DIP Per Cent	%	pear	minus Error Per Cent : DIP Per Cent	%
2	deer			tear			deer		
3	bees			peas			peas		
4	fan			man			man		
5	coat			goat			coat		
I-6	key			pea			key		
7	pup			cup			cup		
8	goat			boat			goat		
9	pea			tea			tea		
P-10	meat			beet			meat		
11	saw			paw			saw		
12	chain			cane			cane		
13	wheel			seal			wheel		
14	cheese			keys			keys		
15	wing			ring			ring		
16	rat			bat			rat		
17	sail			tail			tail		
VI-18	coat	boat	coat						
19	bow	toe	toe						
20	toy	boy	boy						
21	back	tack	back						
22	cat	bat	cat						
23	pot	dot	dot						
24	bone	cone	bone						
25	bee	key	bee						
VP-26	nail	sail	sail						
27	men	pen	men						
28	sun	gun	sun						
29	feet	beet	feet						
IP-30	cat	hat	hat						
31	fire	tire	fire						
32	horn	corn	horn						
33	pear	hair	hair						
34	dog	log	log						
35	can	fan	can						
36	peas	cheese	peas						
37	shoe	two	shoe						
VIP-38	light	kite	kite						
39	cheese	bees	bees						
40	rose	toes	rose						
41	rain	cane	rain						
42	hat	bat	hat						
43	gum	thumb	gum						
44	log	hog	log						
45	four	door	four						
46	man	can	can						
47	suit	boot	suit						
48	bear	hair	hair						

DIP test scoring table: Error Score converted to DIP per cent correct :

<u>Error</u> <u>Score</u>	<u>DIP</u> <u>Per Cent</u>	<u>Error</u> <u>Score</u>	<u>DIP</u> <u>Per Cent</u>
0	100	19	60
1	98	20	58
2	96	21	56
3	94	22	54
4	92	23	52
5	89	24	50
6	87	25	47
7	85	26	45
8	83	27	43
9	81	28	41
10	79	29	39
11	77	30	37
12	75	31	35
13	73	32	33
14	71	33	31
15	68	34	29
16	66	35	26
17	64	36	24
18	62	37	22

XVII

SCORES FOR AGE GROUPS ON DIP TEST

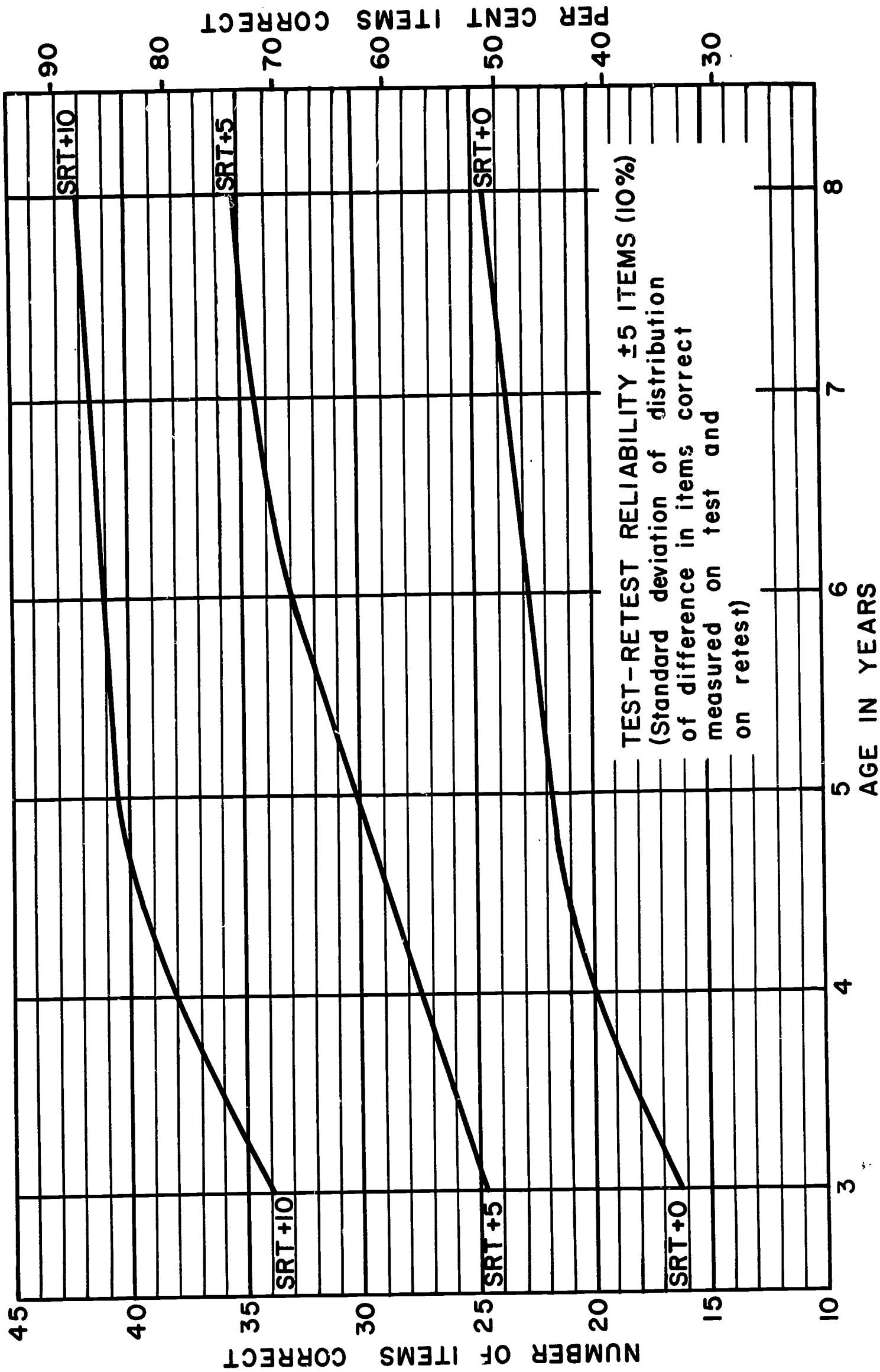

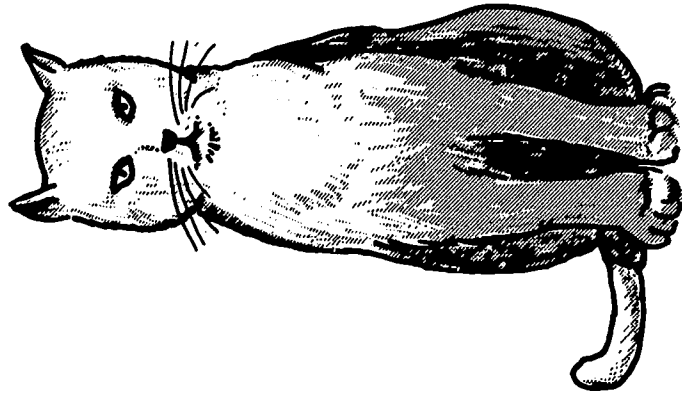
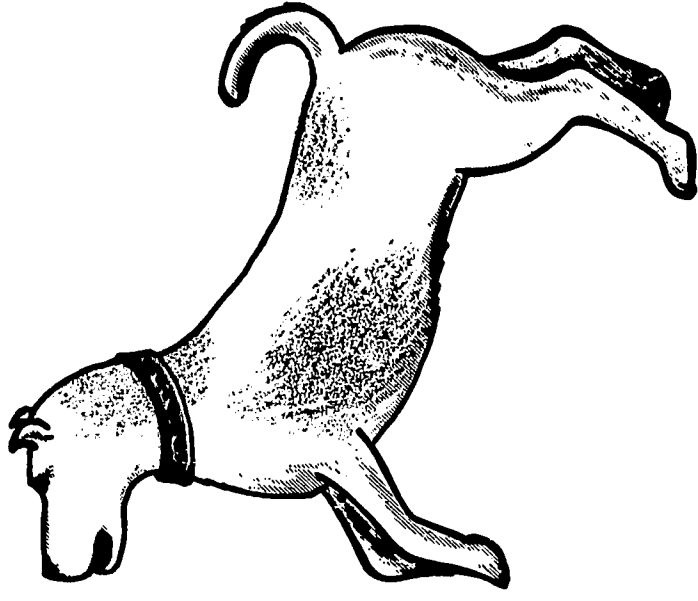

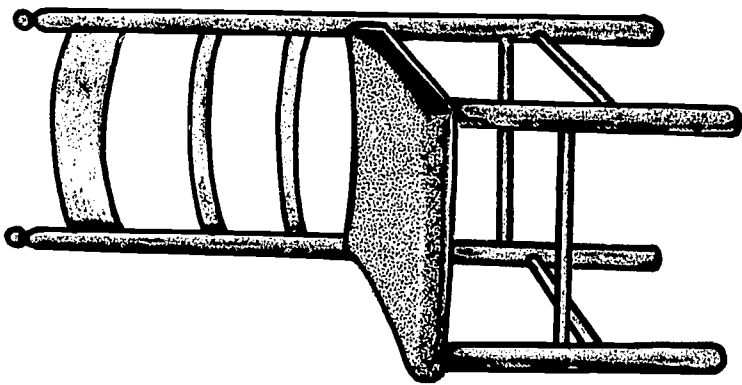
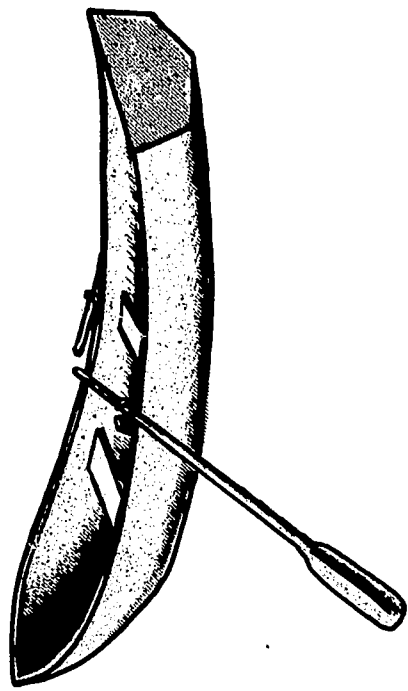

DIP B PRACTICE

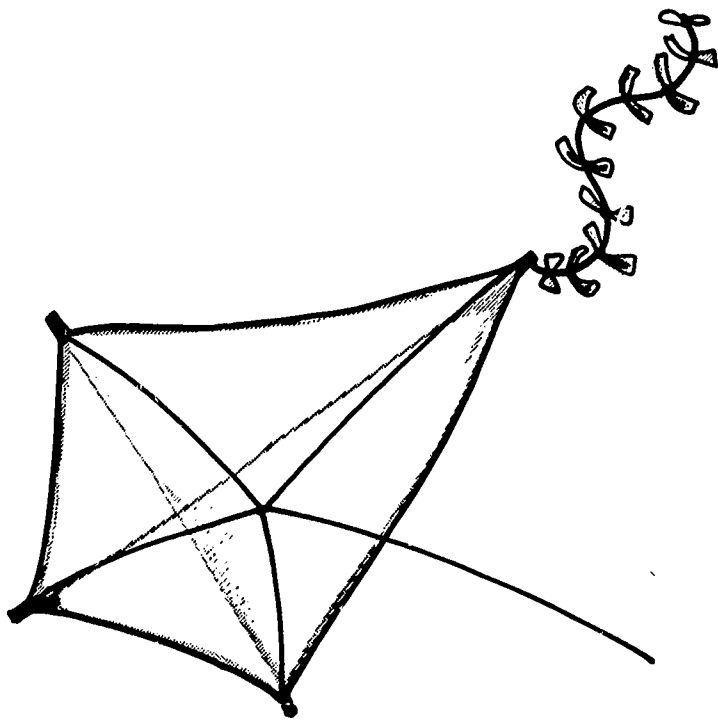

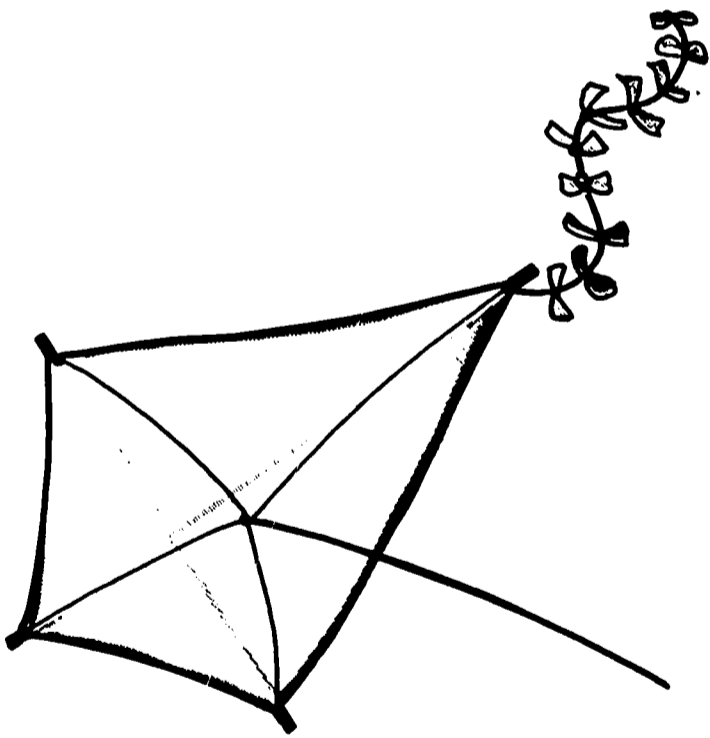
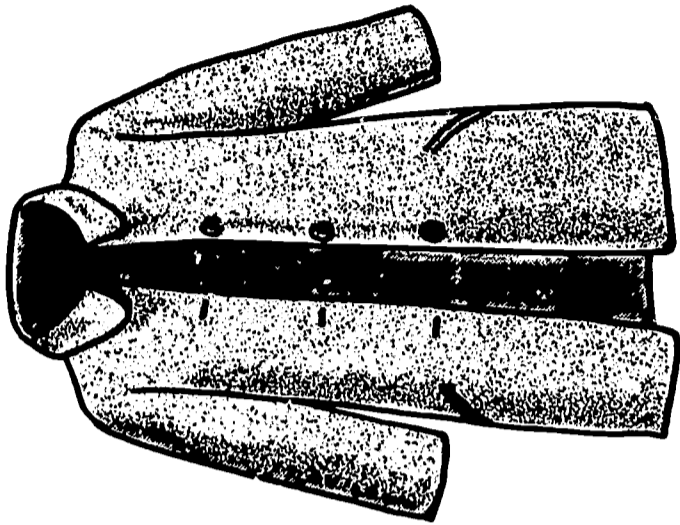

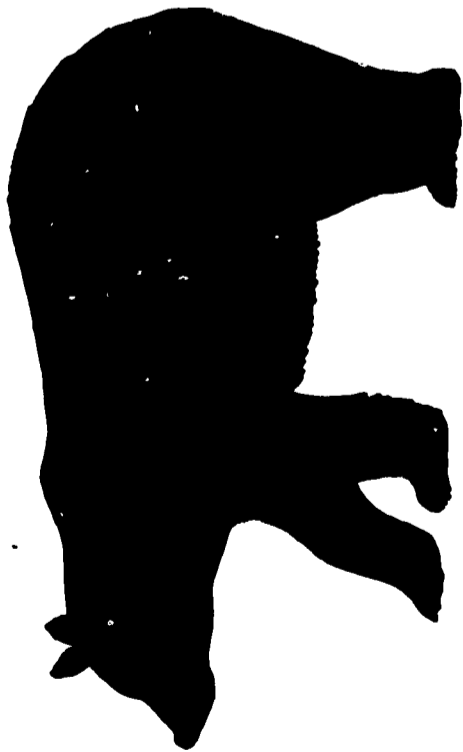
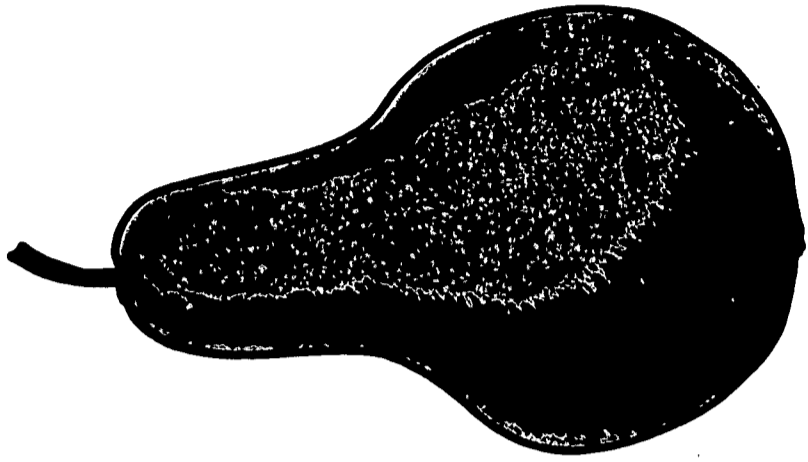

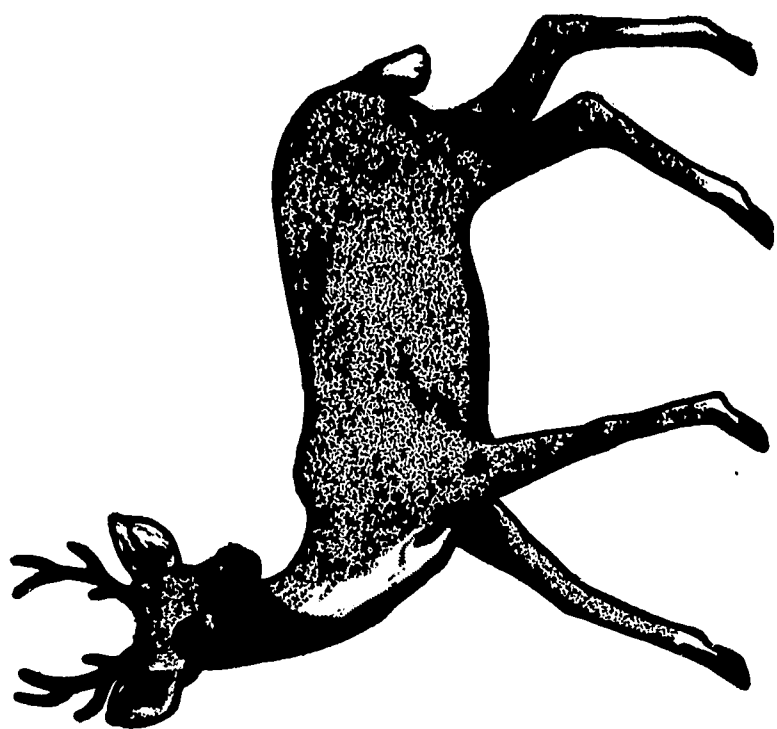

DIP V 2

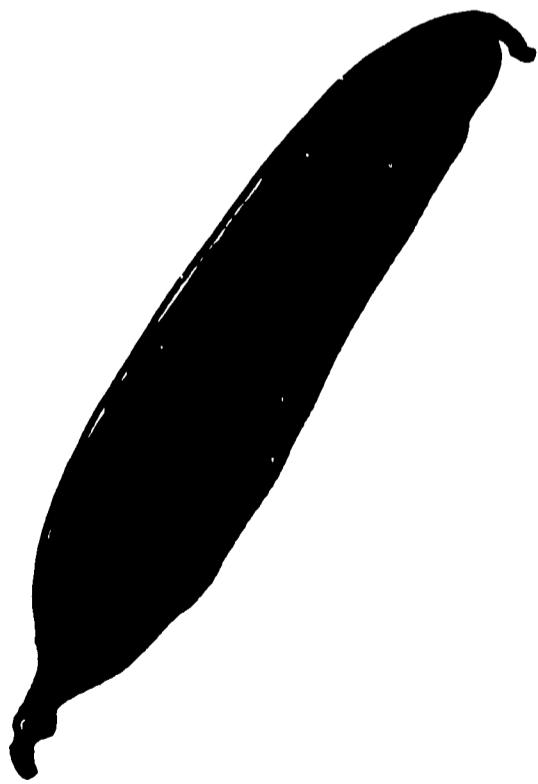

DIP V 3

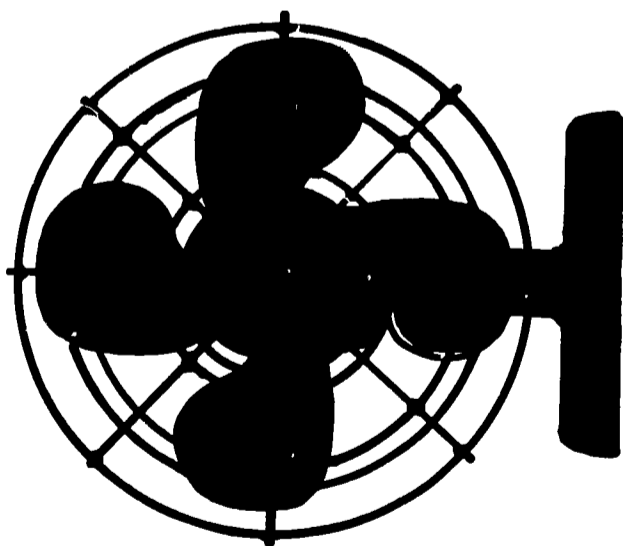
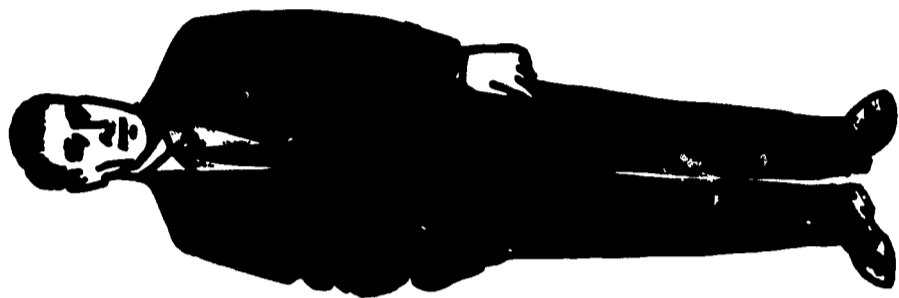

DIP V 4

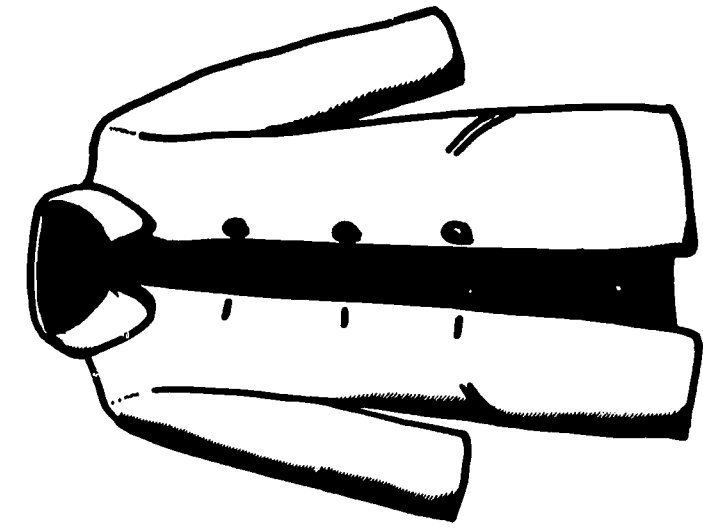

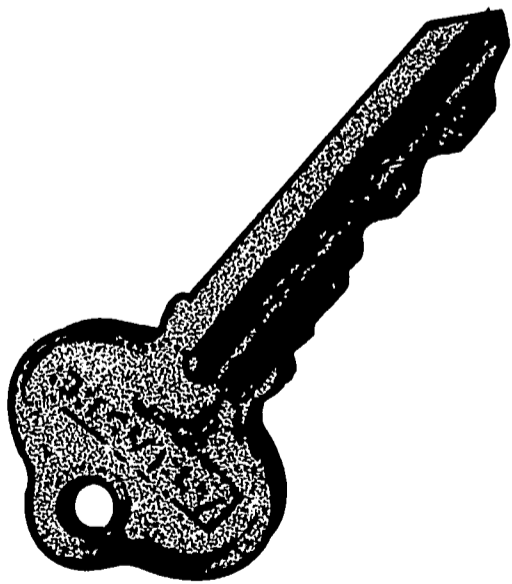
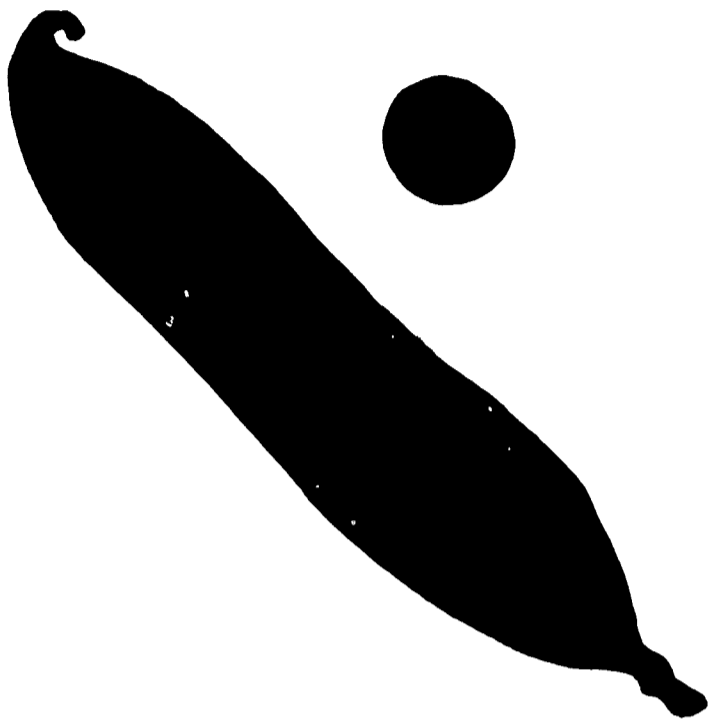

DIP 1 6

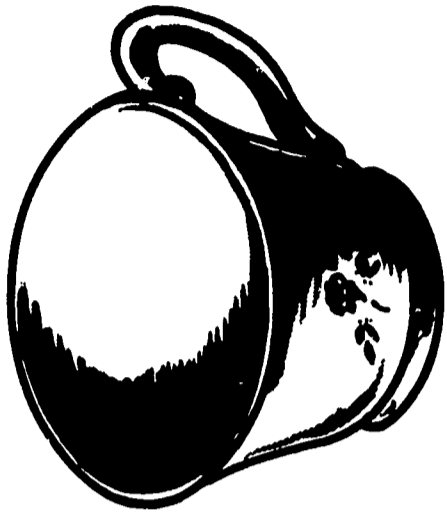



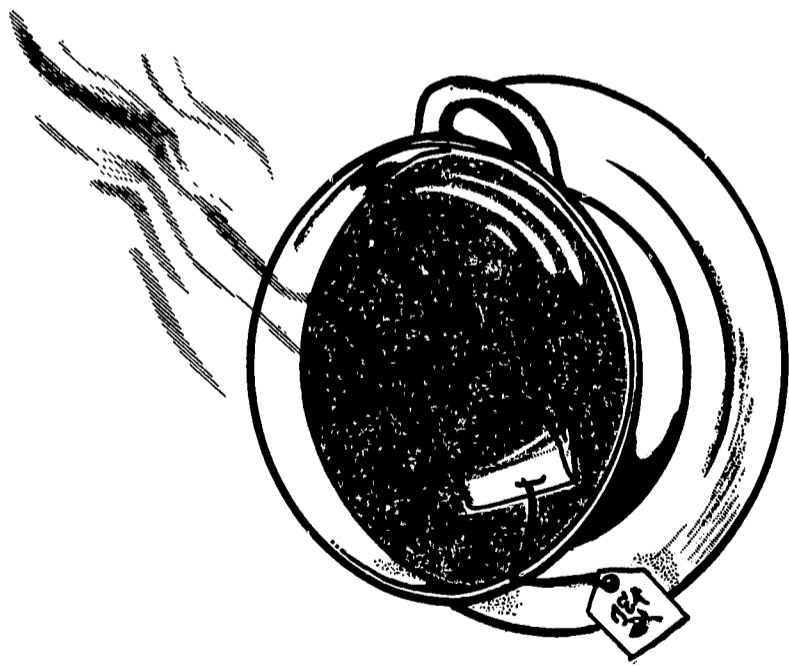
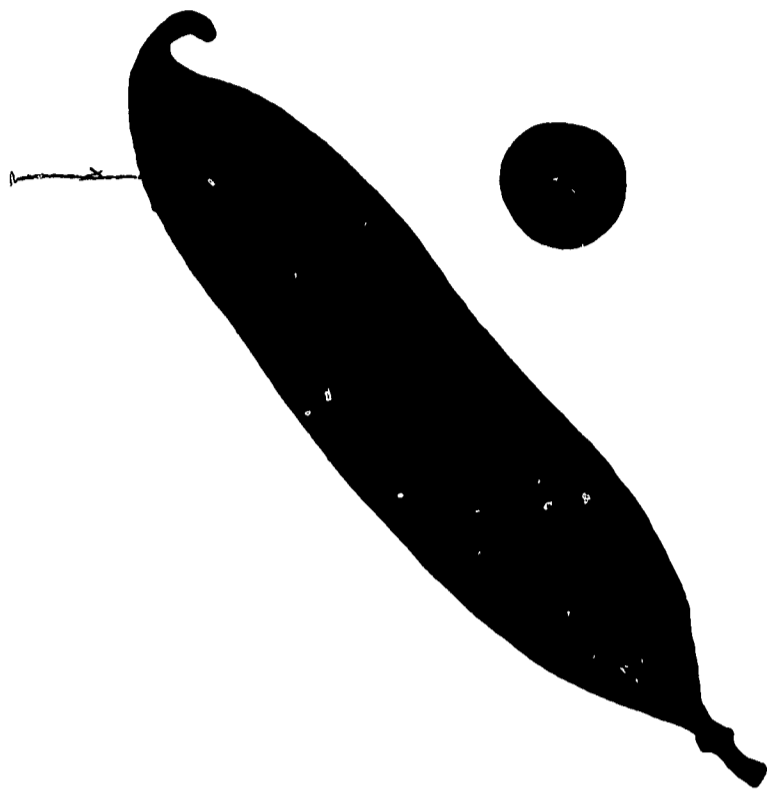

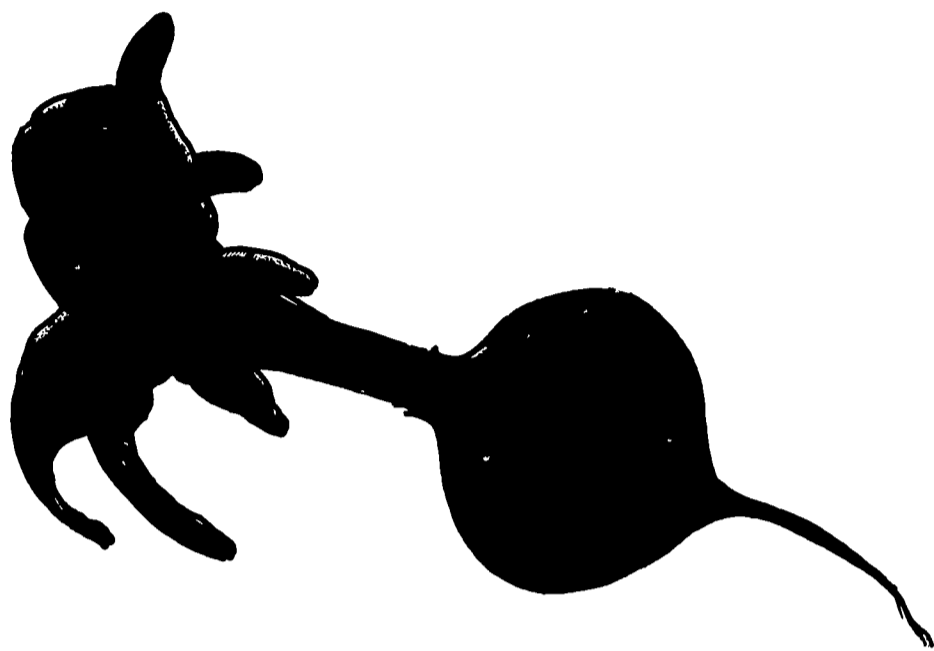

DIP P 10



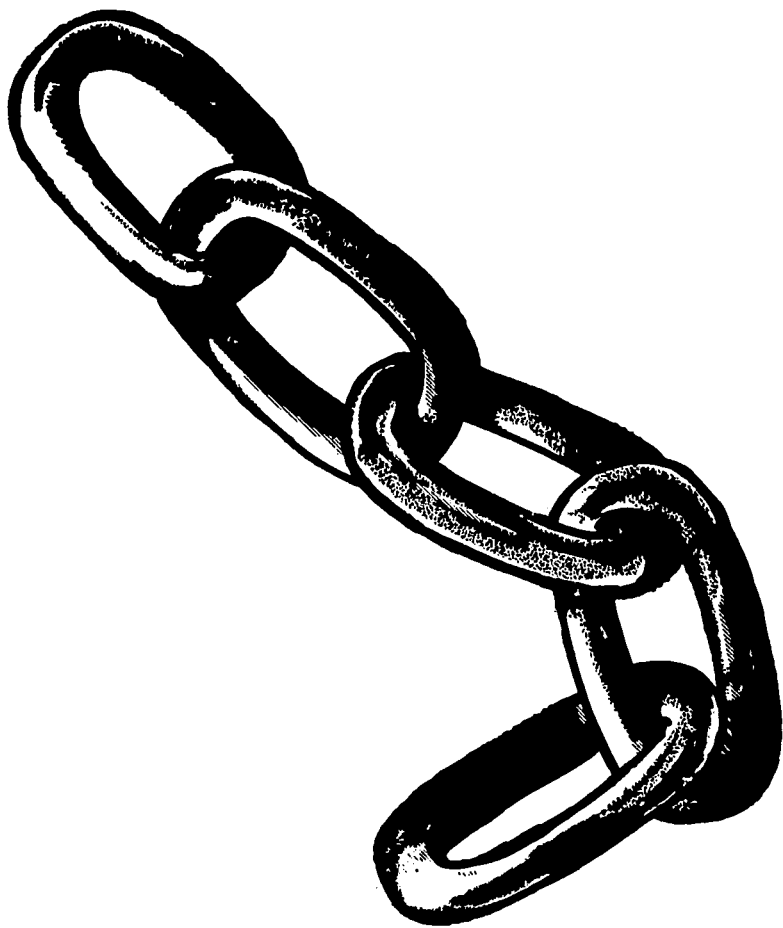
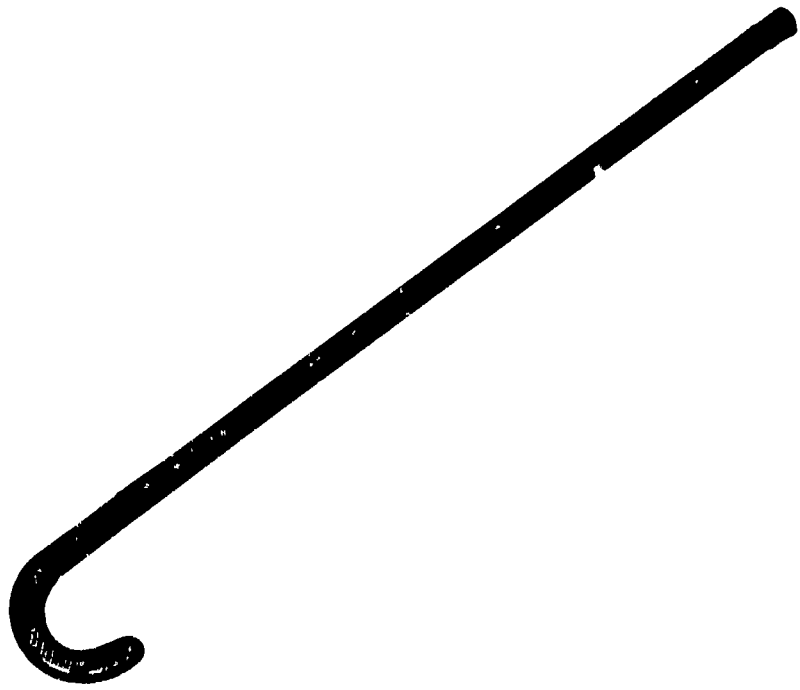

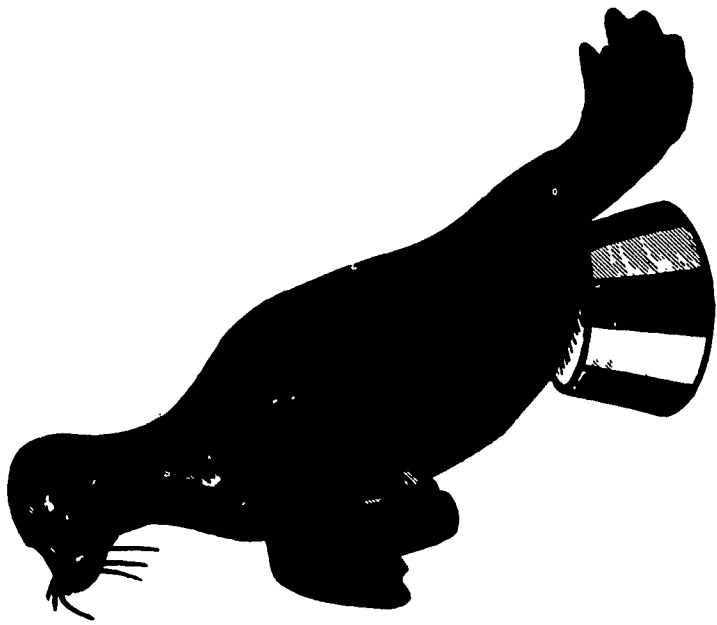
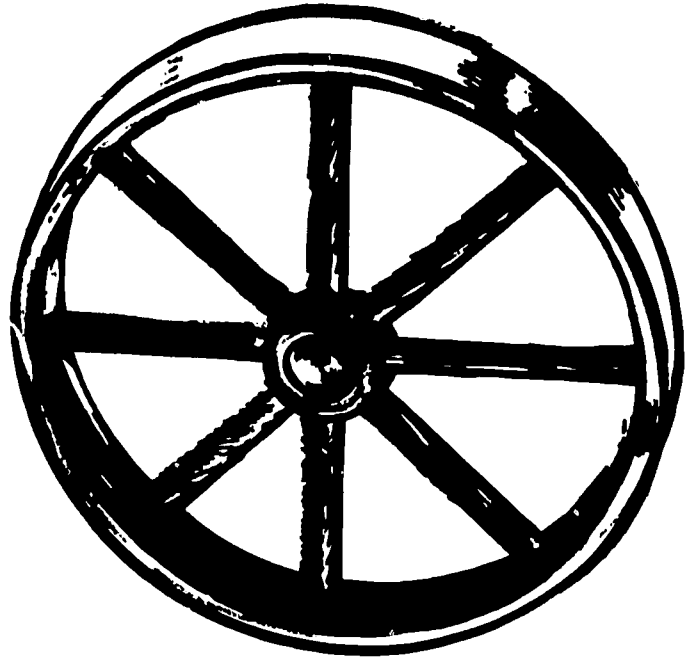

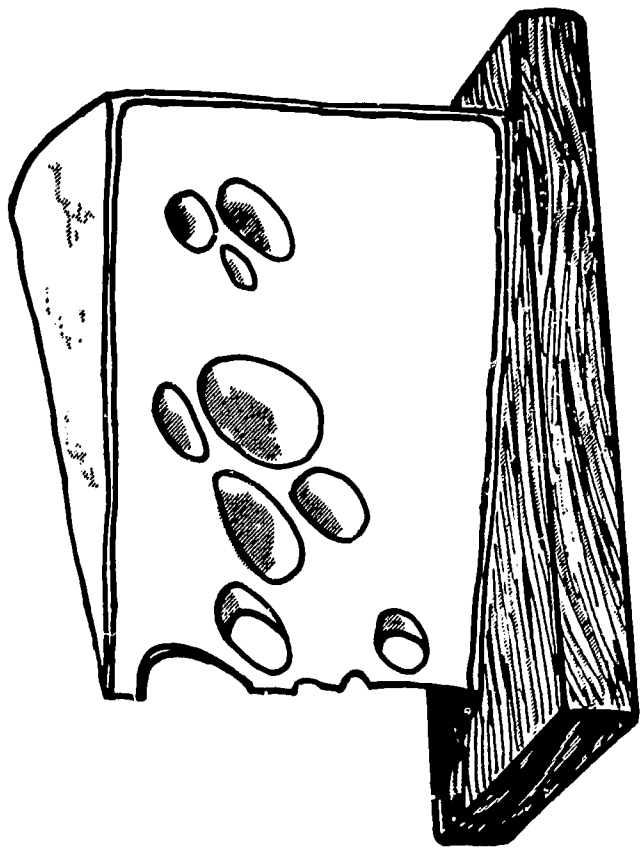
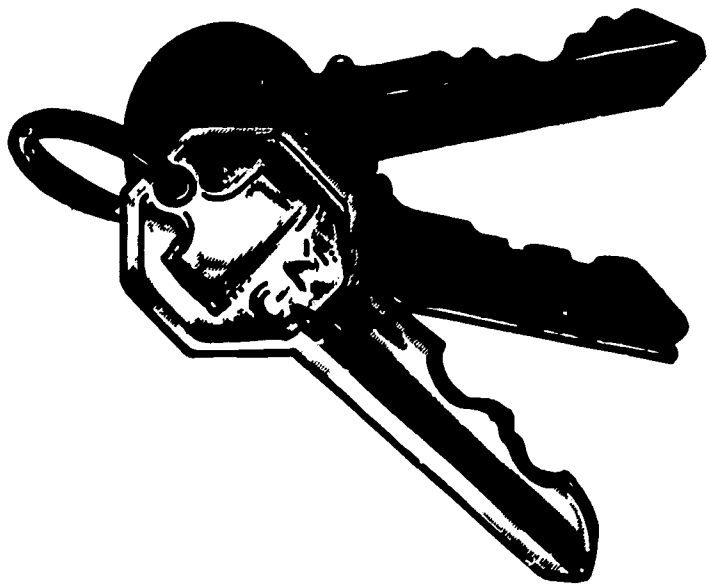



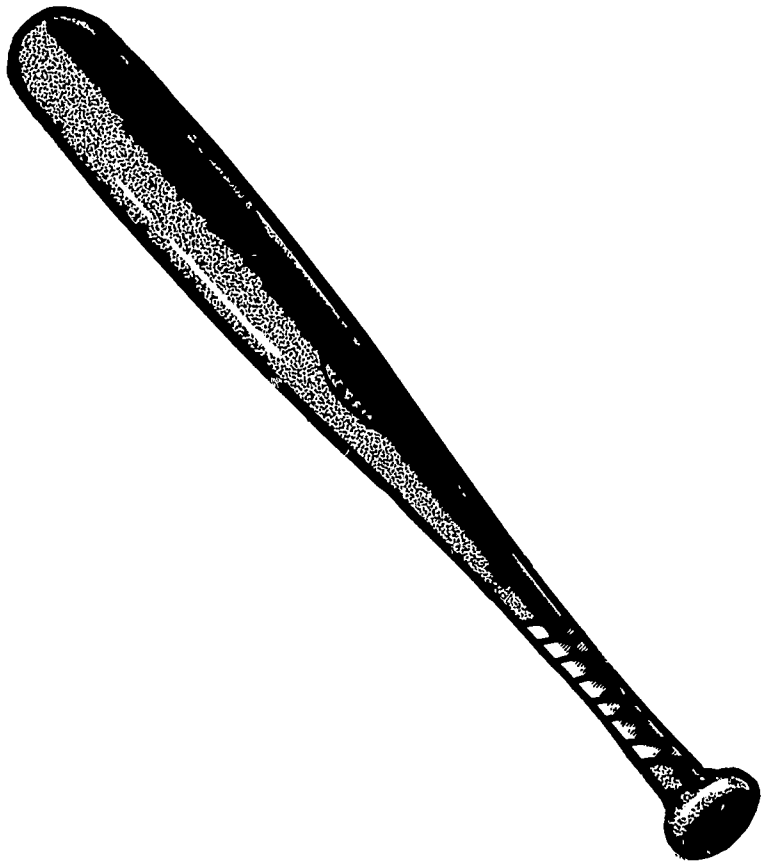

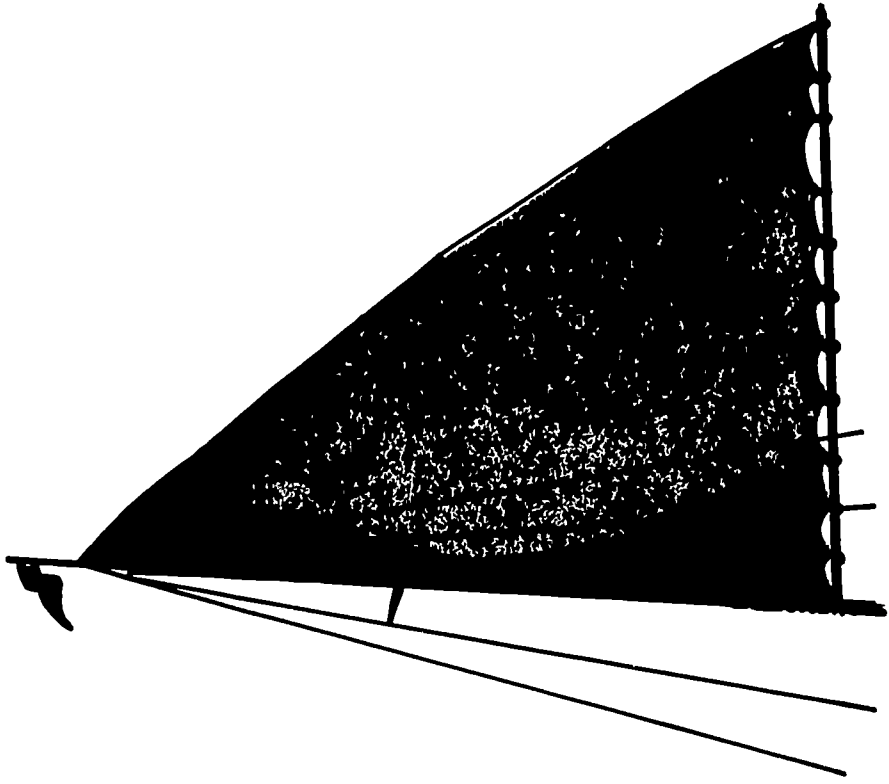

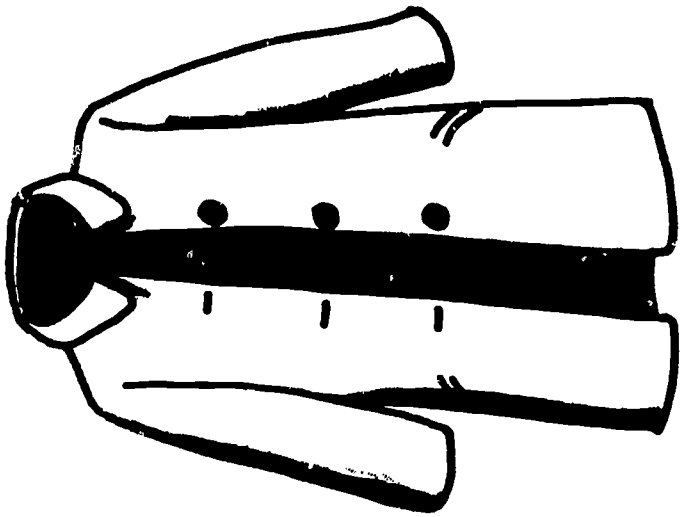

DIP VI 18

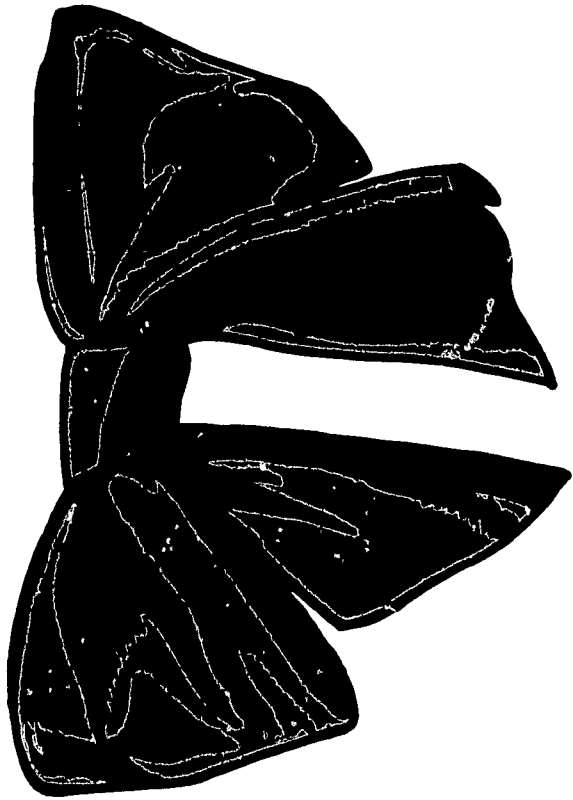

DIP VI 19

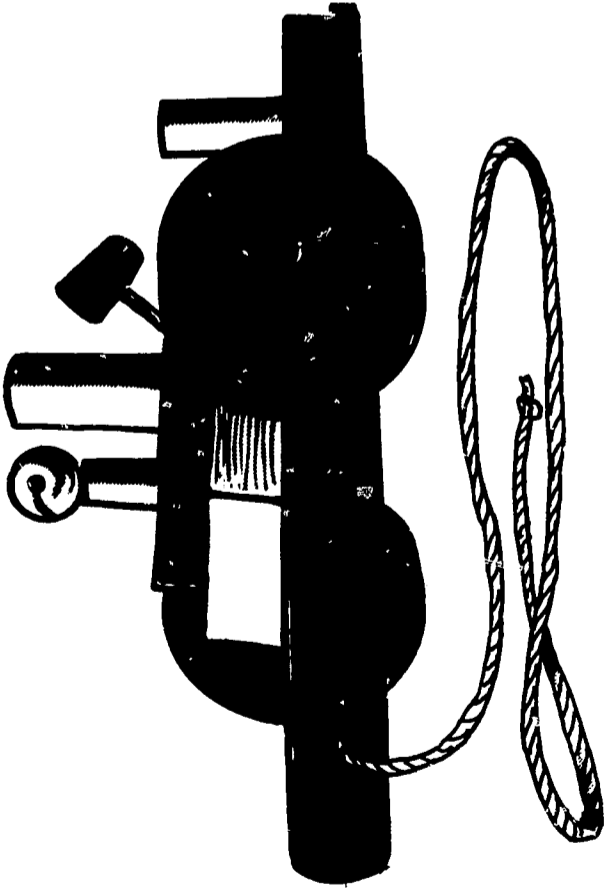
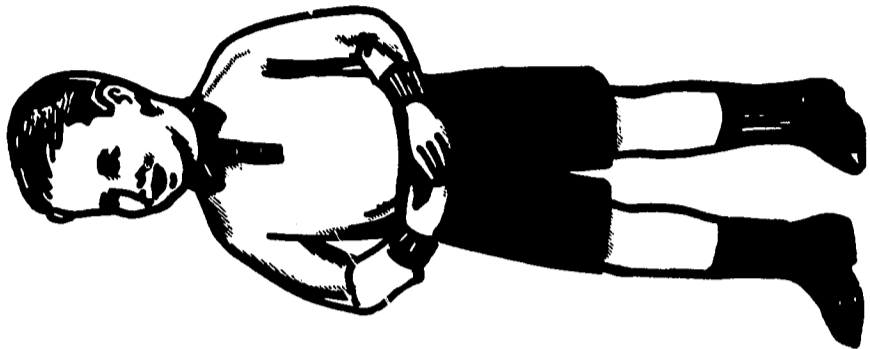

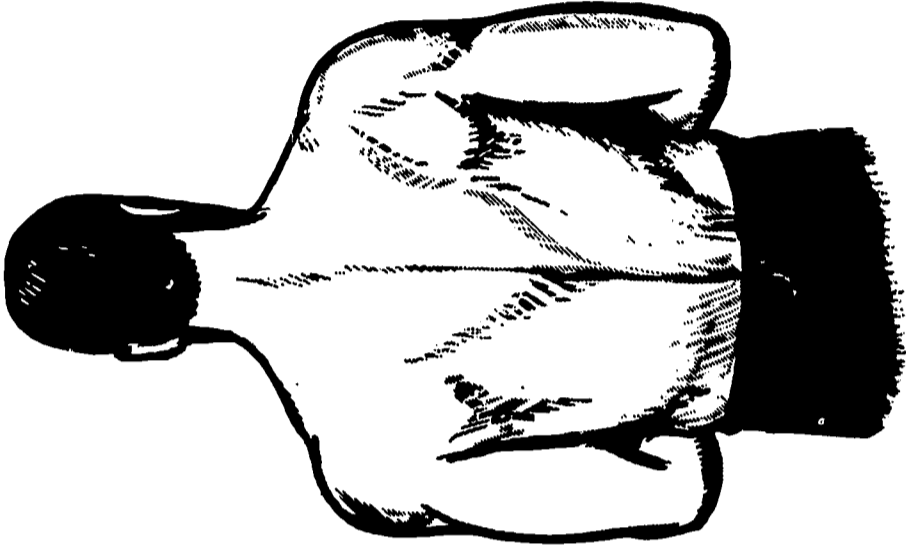

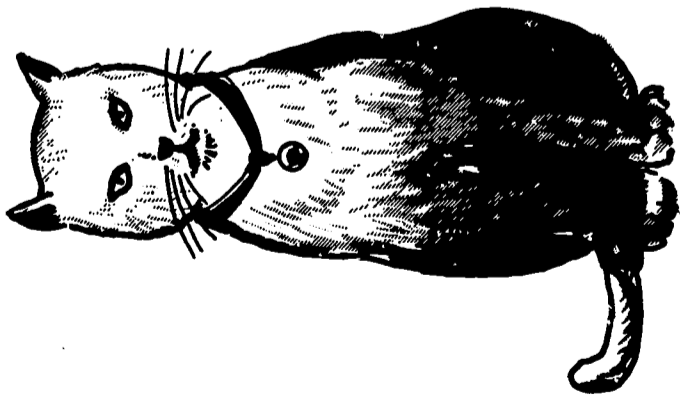
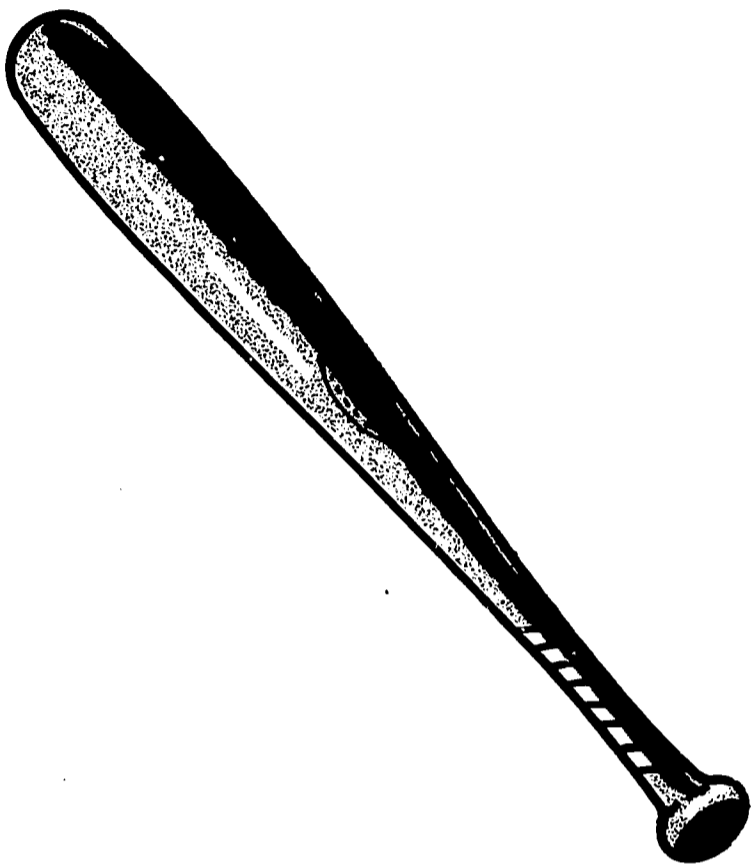

DIP VI 22

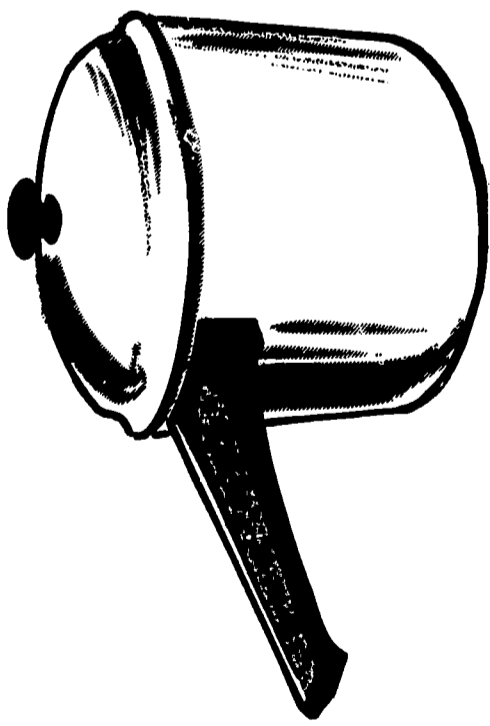

47

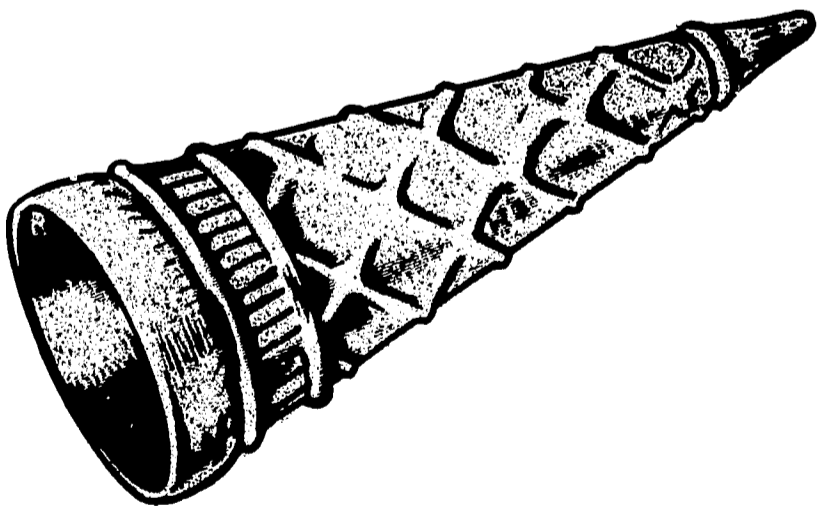
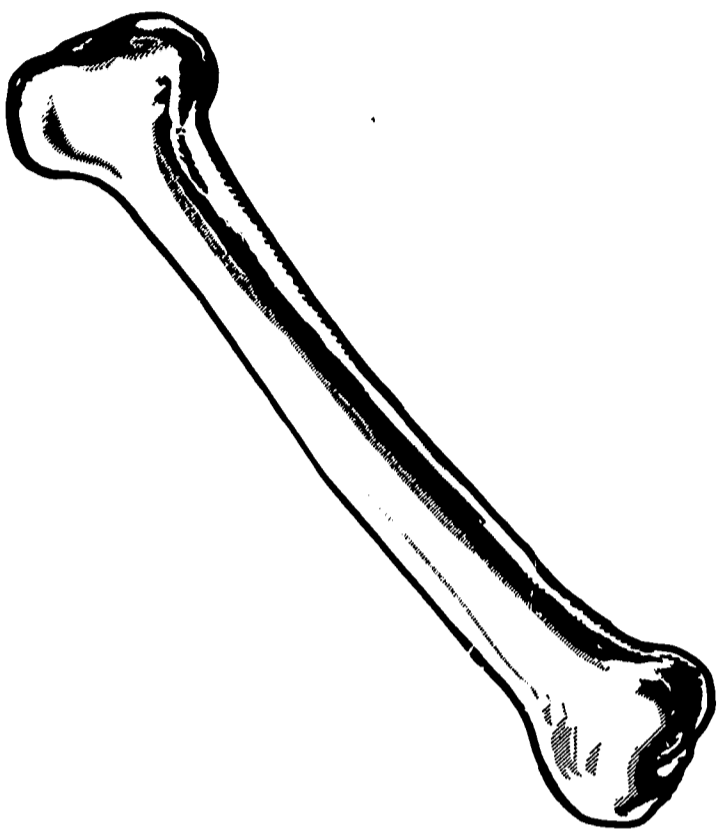

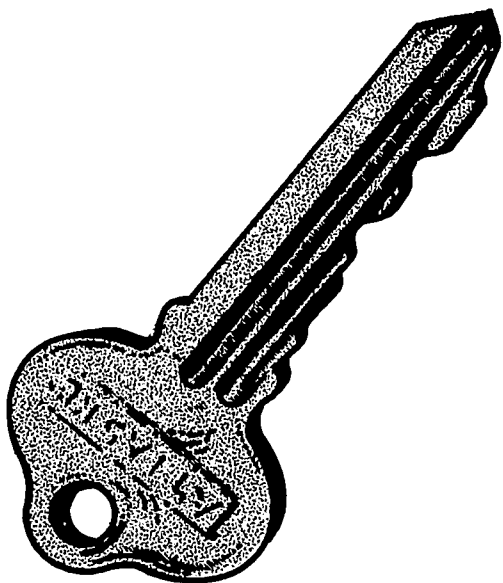

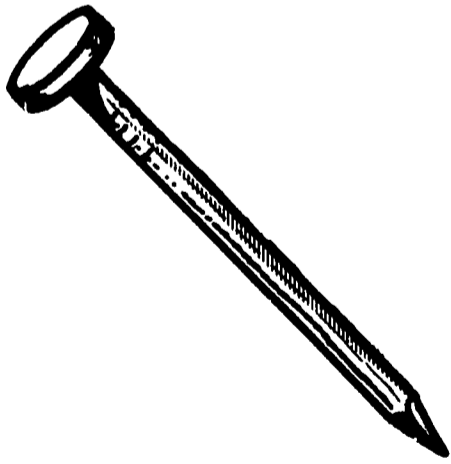
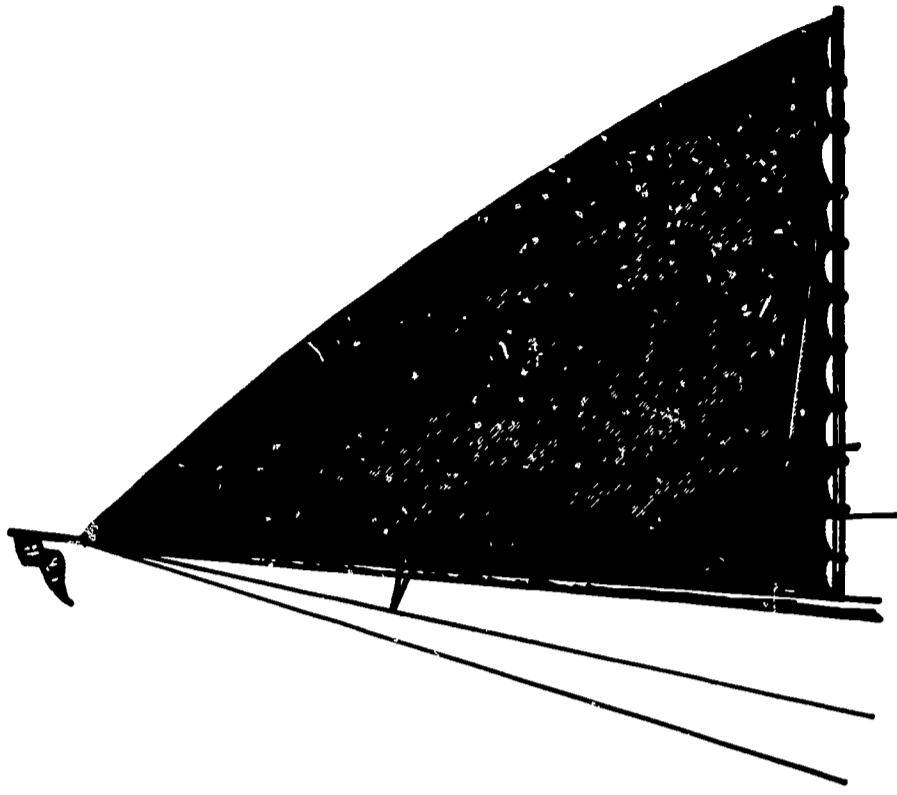

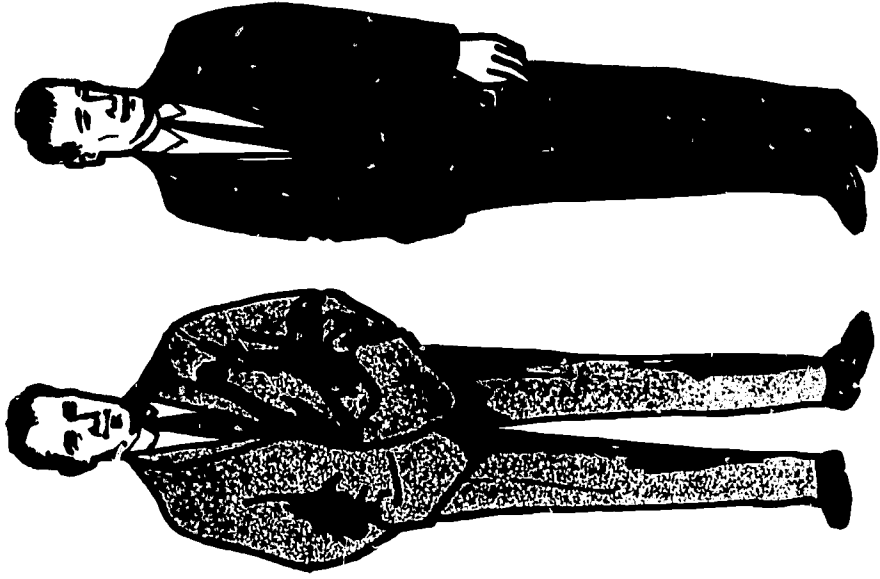

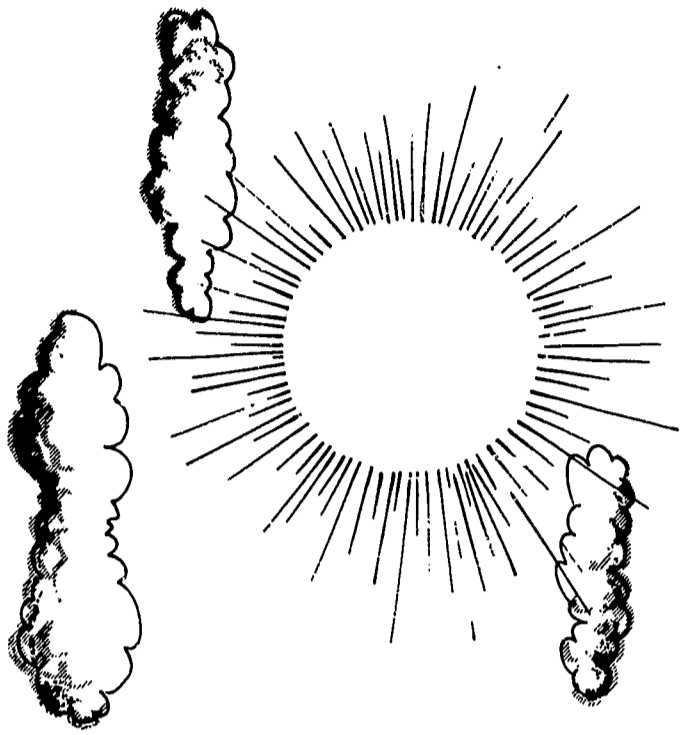

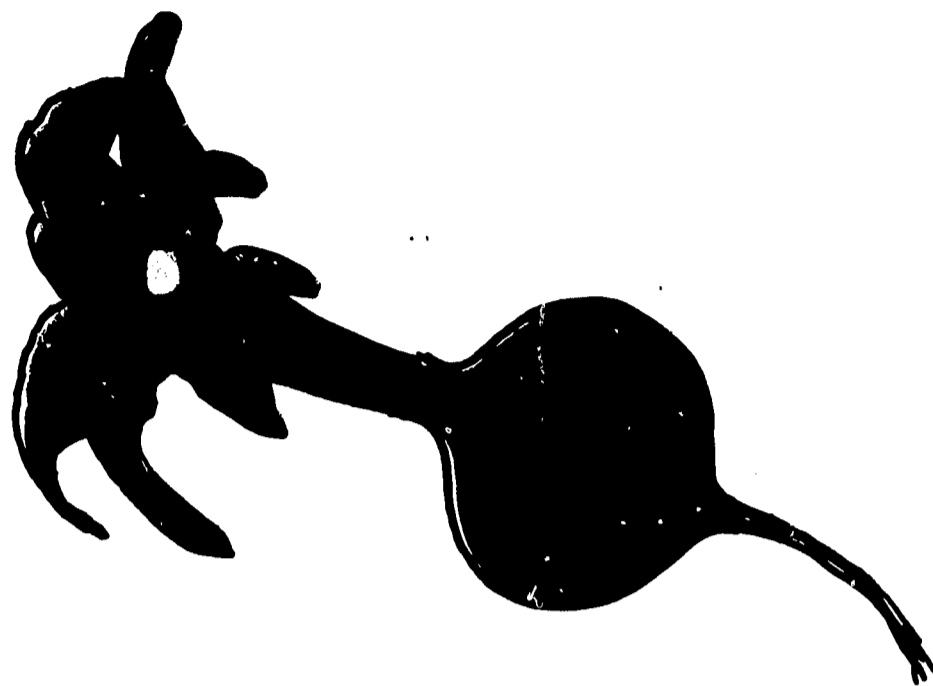

DIP VP 29

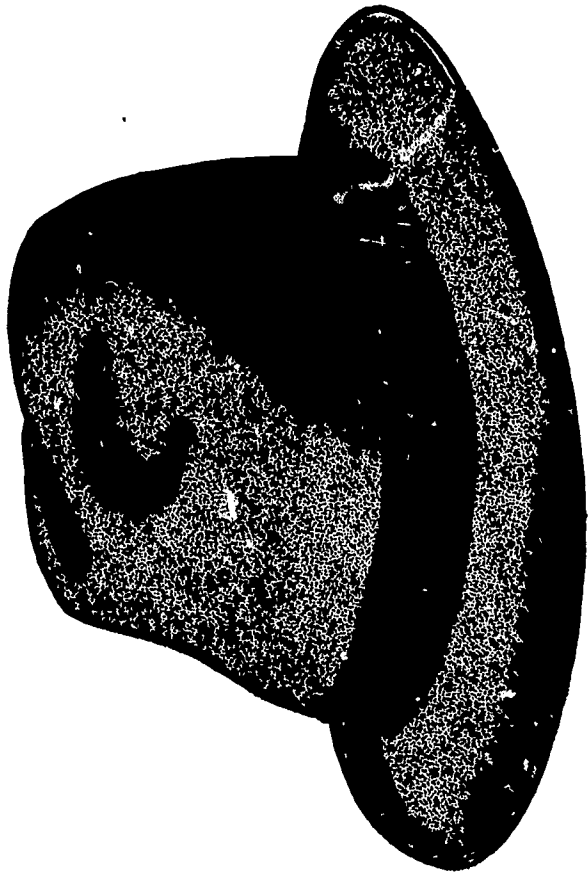
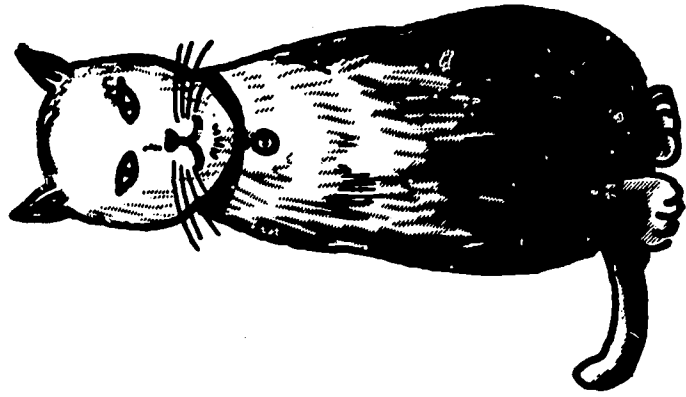

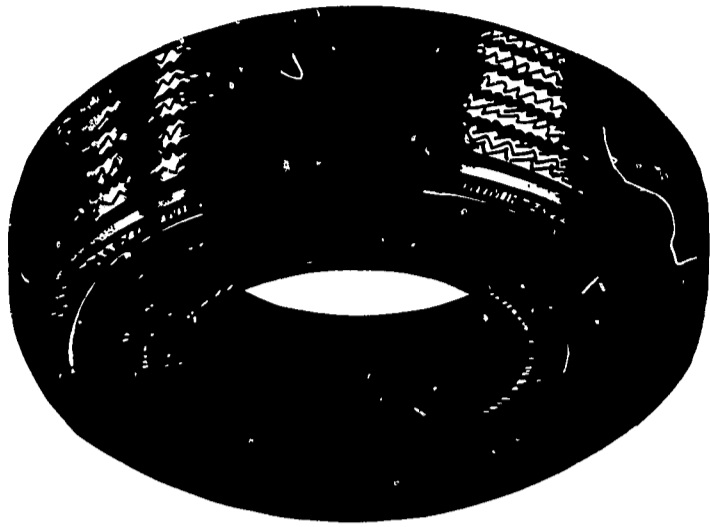

DIP IP 31

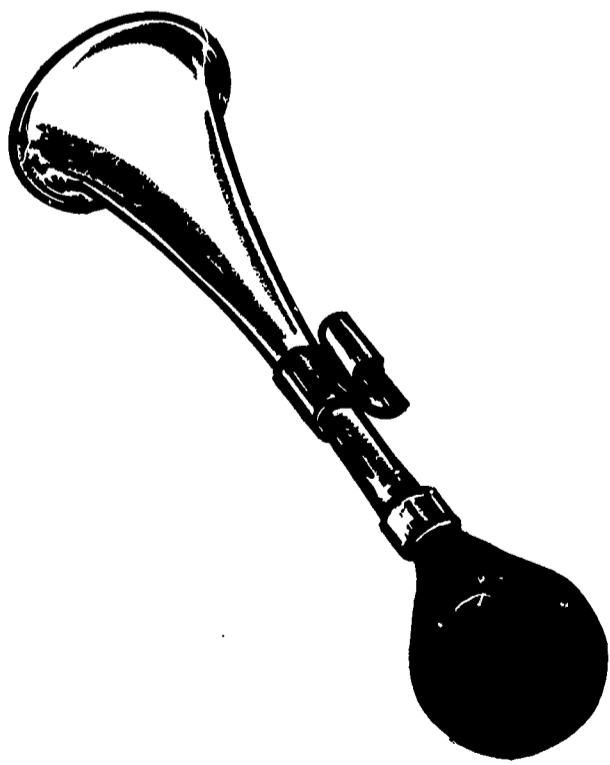
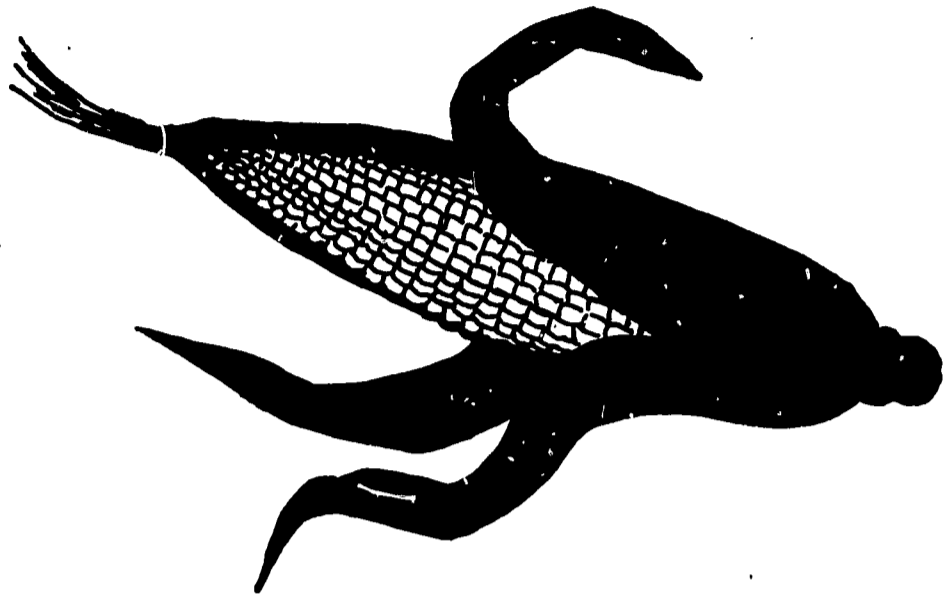

DIP IP 32

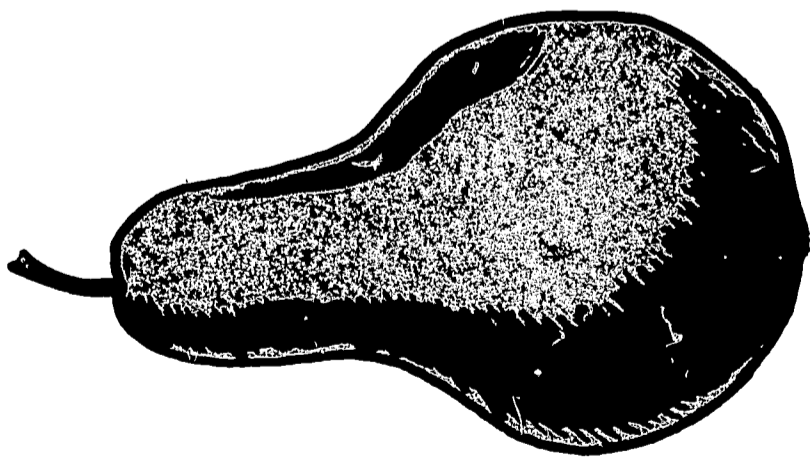
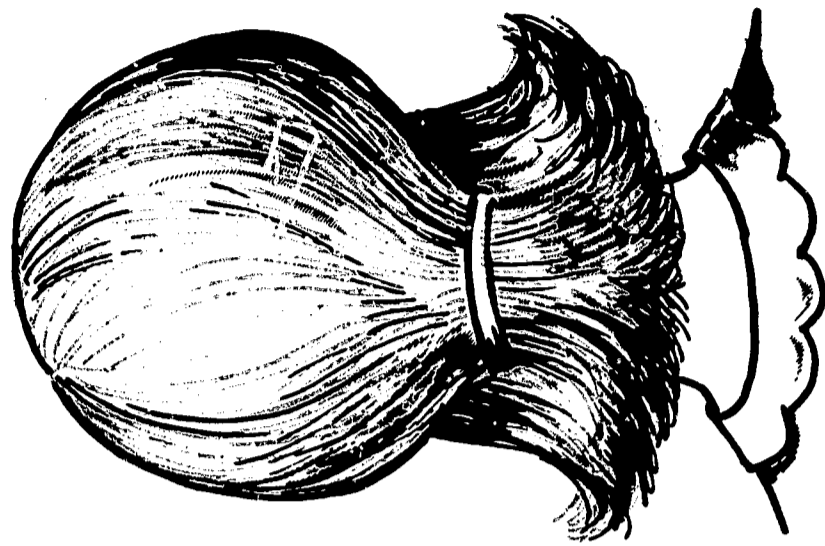

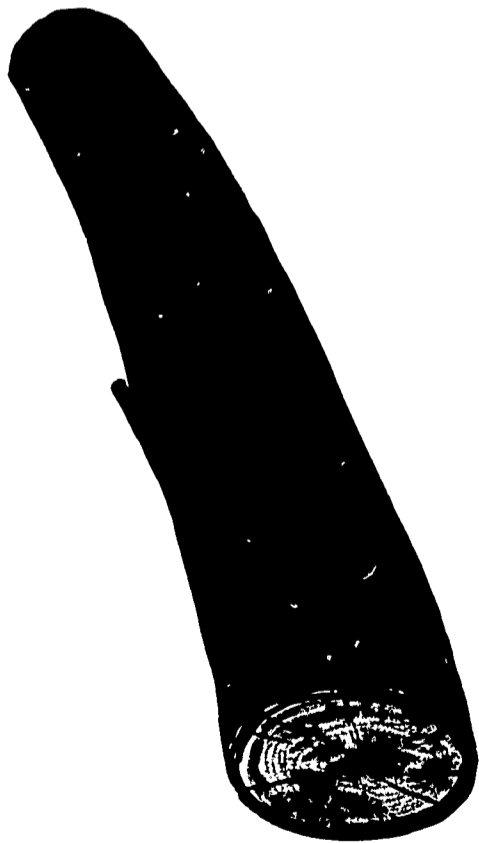

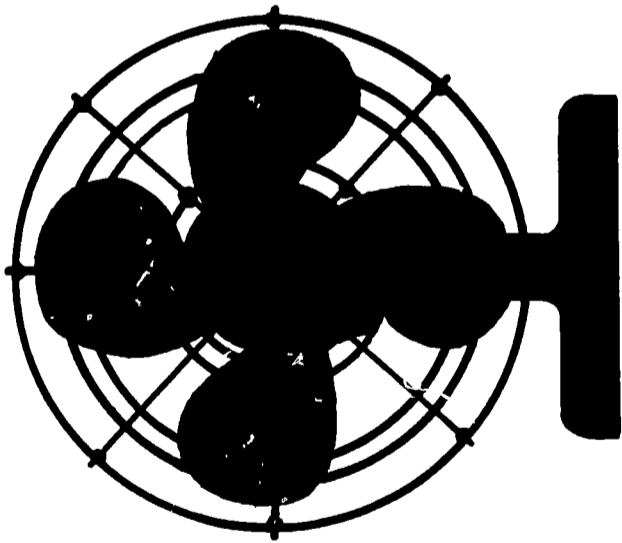
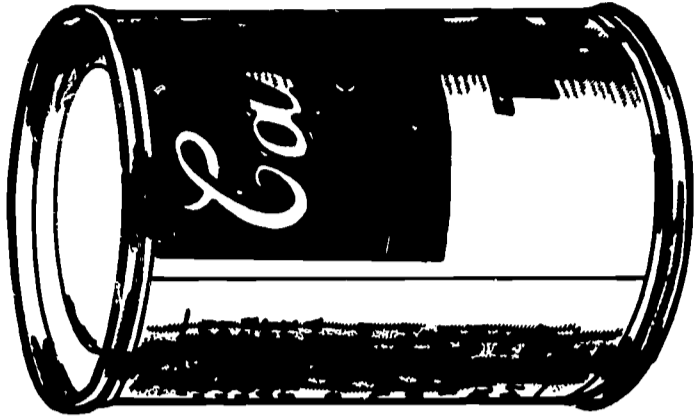

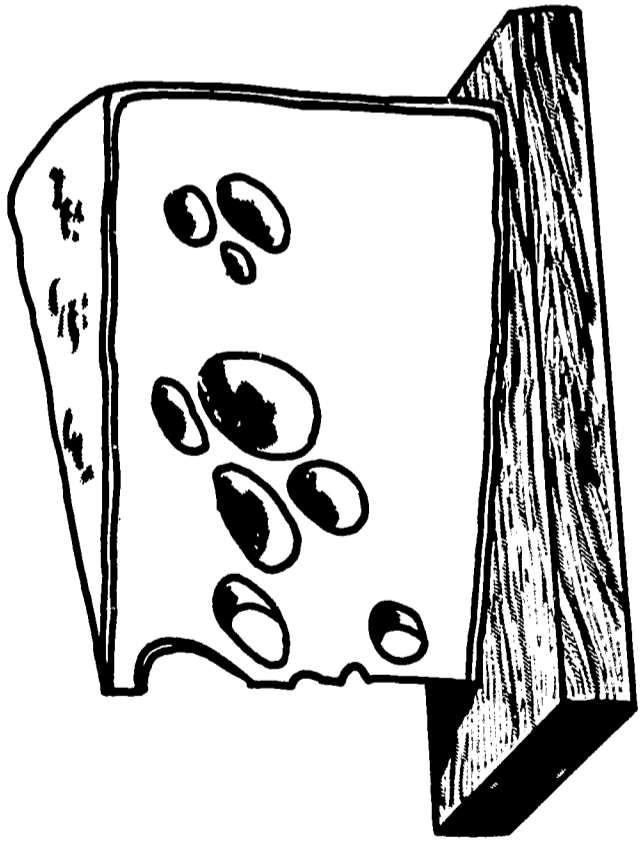
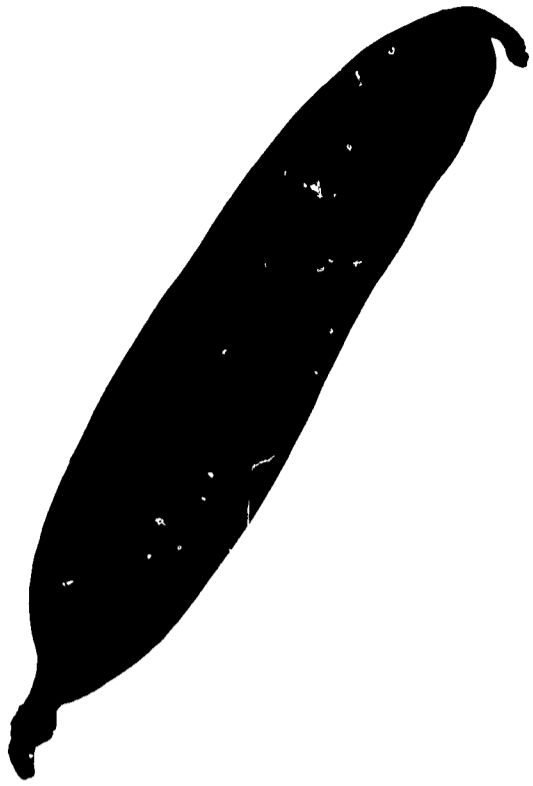

2



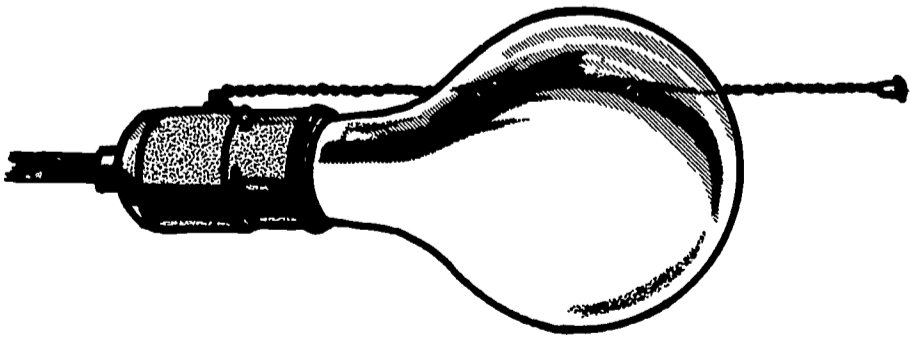
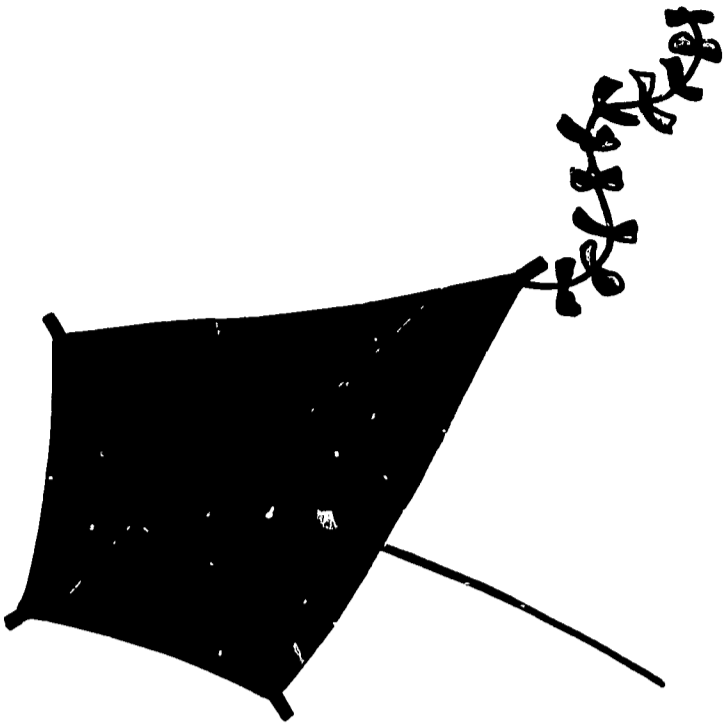

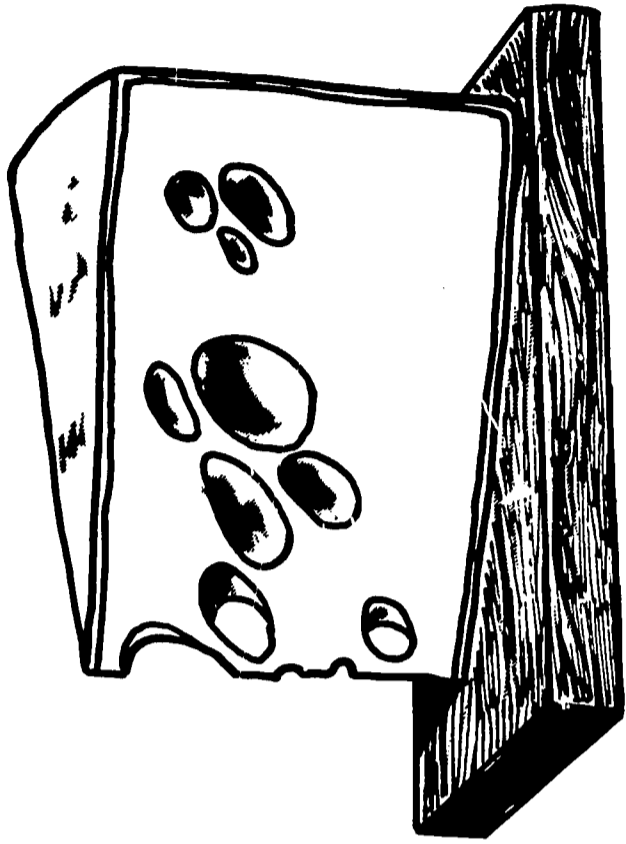



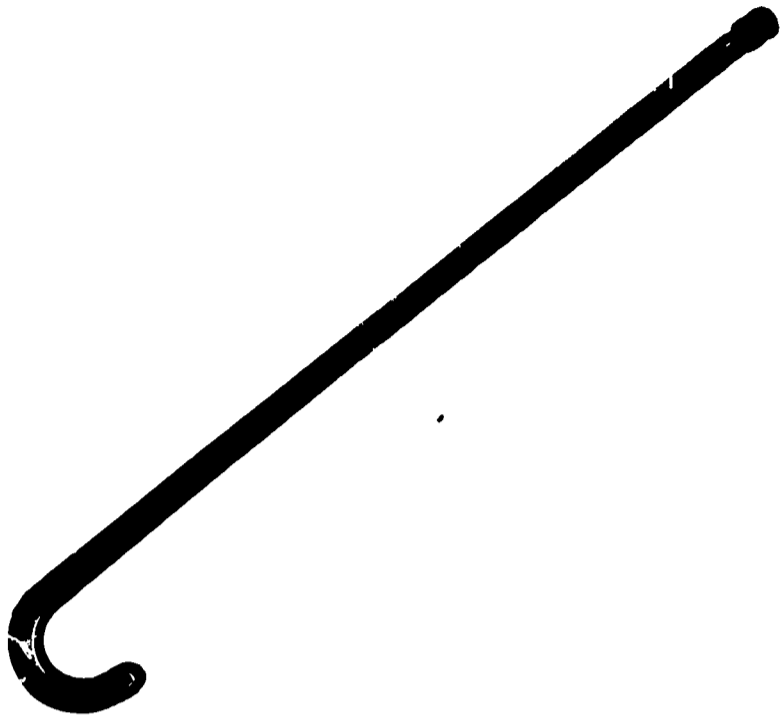

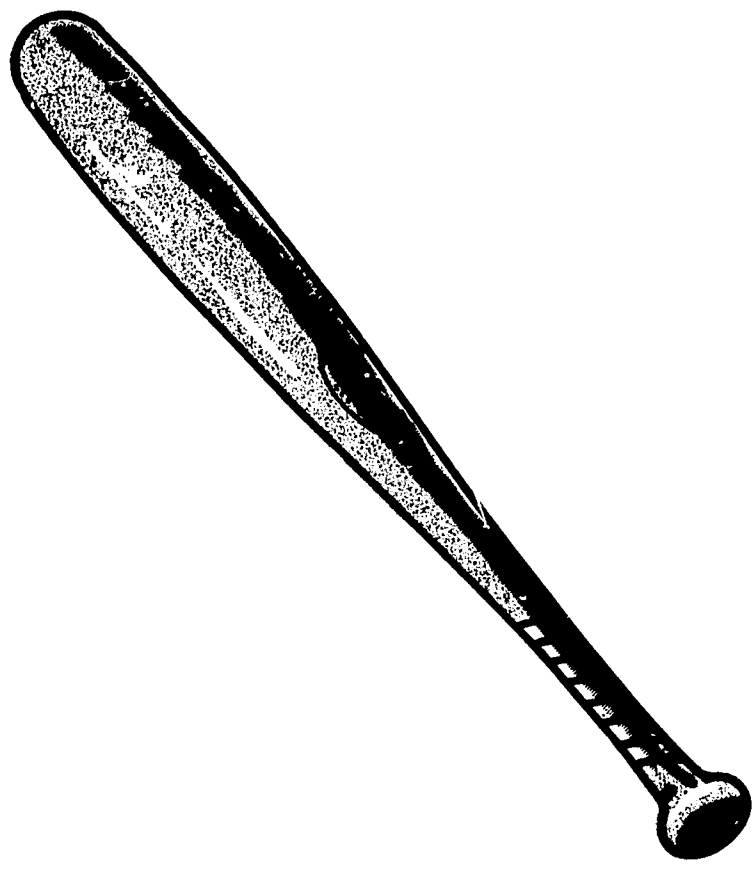
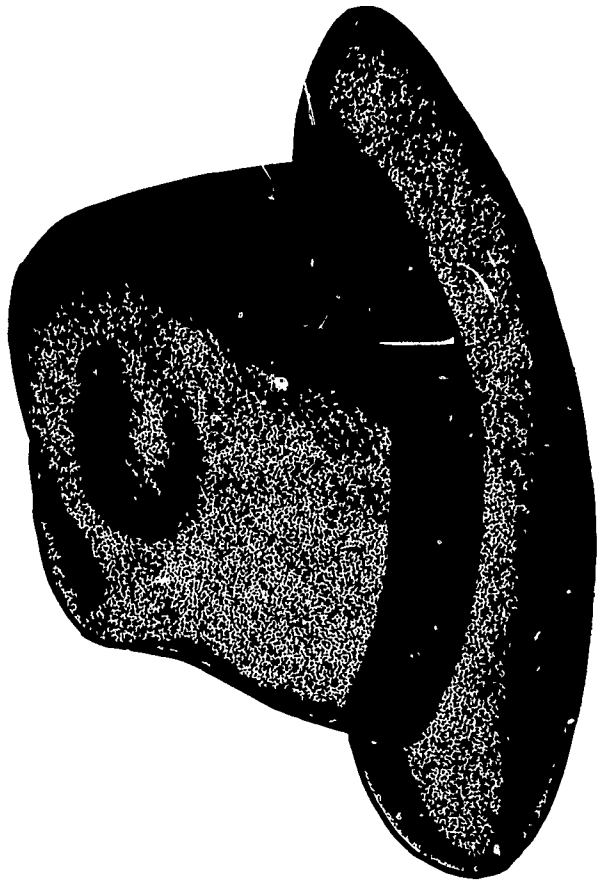

DIP VIP 42

