

R E P O R T R E S U M E S

ED 015 765

LI 000 062

EDUCATION FOR HEALTH SCIENCES LIBRARIANSHIP, PROCEEDINGS OF  
AN INVITATIONAL CONFERENCE (SEATTLE, SEPTEMBER 10-12, 1967).  
BY- LIEBERMAN, IRVING  
WASHINGTON UNIV., SEATTLE

PUB DATE 68

EDRS PRICE MF-\$0.75 HC-\$7.16 177P.

DESCRIPTORS- \*MEDICAL LIBRARIES, \*LIBRARIANS, \*LIBRARY  
EDUCATION, \*LIBRARY SCHOOLS, \*CURRICULUM DEVELOPMENT,  
AUDIOVISUAL AIDS, EDUCATIONAL PROGRAMS, MEDICAL LIBRARIES,  
CONFERENCES, INFORMATION SYSTEMS, MEDICAL RESEARCH, SYSTEMS  
CONCEPTS, PARAMEDICAL OCCUPATIONS, SEATTLE.

MEDICAL LIBRARIANS, HEALTH SCIENCE FACULTY, AND  
SPECIALISTS IN RELATED AREAS WERE PARTICIPANTS IN A  
CONFERENCE HELD TO EXAMINE THE NEEDS AND REQUIREMENTS FOR  
HEALTH SCIENCE LIBRARIANSHIP AND DEVELOP SUGGESTIONS FOR  
APPROPRIATE LIBRARY SCHOOL PROGRAMS. THIS REPORT CONTAINS THE  
COMPLETE TEXTS OF WORKING PAPERS PREPARED FOR THE CONFERENCE  
AND MAJOR POINTS FROM THE DISCUSSION SESSIONS. THE TOPICS  
COVERED INCLUDE: (1) CHANGES IN MEDICAL LIBRARIANSHIP, (2) THE  
RELATION OF SPECIAL TO GENERAL LIBRARY EDUCATION, (3) THE  
INFLUENCE OF MEDICAL HISTORY PROGRAMS ON LIBRARIES AND  
LIBRARY SCHOOL CURRICULA, (4) LEVELS OF PREPARATION FOR  
MEDICAL LIBRARIANSHIP, (5) CURRICULUM CONTENT FOR EDUCATION  
IN MEDICAL LIBRARIANSHIP, WITH A REVIEW OF EXISTING PROGRAMS  
AND A PROPOSED DESIGN FOR A SPECIALIZED PROGRAM, (6) TRENDS  
IN THE HEALTH SCIENCES AND THE RESULTANT NEED FOR COMPLEX  
MEDICAL INFORMATION SYSTEMS, (7) EDUCATIONAL PROGRAMS FOR  
HOSPITAL HEALTH SCIENCE LIBRARIANS, (8) SYSTEMS CONCEPTS AND  
LIBRARY EDUCATION, AND (9) MODERN TECHNIQUES OF BIOMEDICAL  
COMMUNICATION, EXTENDED BY A DISCUSSION OF NON-PRINT MEDIA IN  
LIBRARY SCHOOL PROGRAMS. THE PROCEEDINGS ARE CONCLUDED WITH  
THE CONFERENCE RECOMMENDATIONS ON CURRICULUM REQUIREMENTS AND  
FOUR MAIN AREAS FOR FURTHER CONSIDERATION IN EDUCATION FOR  
HEALTH SCIENCE LIBRARIANSHIP. INCLUDED IN THE APPENDIX ARE  
THE CODE FOR TRAINING AND CERTIFICATION OF MEDICAL  
LIBRARIANS, A PAPER ON EDUCATION FOR THE VETERANS  
ADMINISTRATION LIBRARY PROGRAM, BIOGRAPHIES OF PARTICIPANTS,  
AND A SELECTED BIBLIOGRAPHY. "THE USE OF NON-PRINT MEDIA IN  
LIBRARY INSTRUCTION," BY IRVING LIEBERMAN, PARTIALLY INCLUDED  
HERE, WILL APPEAR IN FULL IN "LIBRARY EDUCATION--AN  
INTERNATIONAL SURVEY," EDITED BY LARRY E. BONE, IN 1968. (JB)

LI 000 062

UNIVERSITY OF WASHINGTON SCHOOL OF LIBRARIANSHIP

ED015765

Proceedings of an  
Invitational Conference  
on Education for  
**HEALTH SCIENCES  
LIBRARIANSHIP**

September 10-12, 1967

Edited by Irving Lieberman

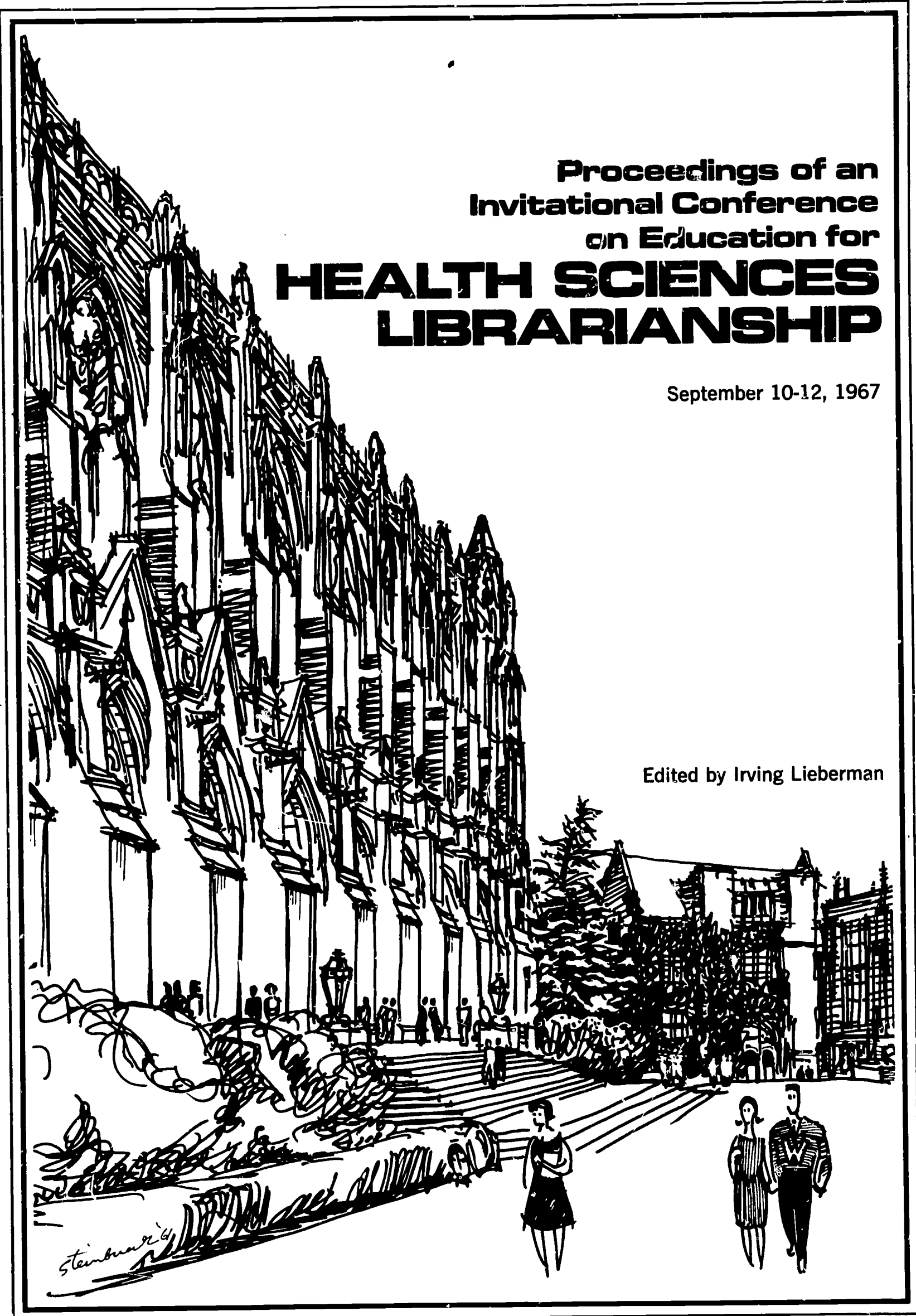

Conference made possible by a grant from the National Library of Medicine of the U.S. Public Health Service

LI 000 062

EDUCATION FOR HEALTH SCIENCES LIBRARIANSHIP

Proceedings of an Invitational Conference  
September 10 - 12, 1967

Edited by

Irving Lieberman

1968

School of Librarianship  
University of Washington  
Seattle, Washington

U.S. DEPARTMENT OF HEALTH, EDUCATION & WELFARE  
OFFICE OF EDUCATION

THIS DOCUMENT HAS BEEN REPRODUCED EXACTLY AS RECEIVED FROM THE  
PERSON OR ORGANIZATION ORIGINATING IT. POINTS OF VIEW OR OPINIONS  
STATED DO NOT NECESSARILY REPRESENT OFFICIAL OFFICE OF EDUCATION  
POSITION OR POLICY.

## INTRODUCTION

New approaches in the education of health sciences librarians have been made necessary by the rapid growth of medical knowledge and changing patterns of medical care. As the practice of health sciences becomes both more specialized and more comprehensive, practitioners and researchers will place increasing demands on library systems, not only for health sciences information but also in the related fields of behavioral and social sciences. This means that larger numbers of people must be attracted to careers in health sciences librarianship and they must have the capability to plan and design information and communication systems that will meet the expanding and changing demands.

For some time the School of Librarianship at the University of Washington had been considering the advisability of embarking upon a specialized degree program in health sciences librarianship. The need for the development of this type of program has been evident throughout the country and it had received special attention in Washington State with the legislative approval of a new program for hospital and institution library development in 1965. While it is true that individual courses in medical bibliography are becoming more readily available, full-time programs of education for health sciences librarianship are few or nonexistent. Because the School of Librarianship has had a long successful history with its curriculum in Law Librarianship, culminating in a specialized degree, our faculty believes that it would be important to develop a post-baccalaureate program of education which would lead to a health sciences librarianship degree. Cross-overs would also be considered between such a master's curriculum and (1) information science, (2) bibliography for the physical sciences, and (3) the general librarianship curricula.

Early in 1966, a small planning committee made up of members of the faculty of the School of Librarianship, the Health Sciences faculty and Health Sciences Library at the University of Washington began to hold regular meetings on this matter. The group decided to develop a proposal for a grant for submission to the National Library of Medicine of the U.S. Public Health Service for the purpose of convening a small nation-wide invitational conference of knowledgeable medical librarians, health sciences faculty as well as other specialists. The objectives of the conference were to examine the needs and requirements of health sciences librarianship today and develop through working papers and discussions, suggestions for the curriculum requirements and/or to present a framework which any graduate library school might use in developing a program for health sciences librarianship. The concerns of such a framework would include not only course development but also facilities and personnel.

With the approval of the grant in March 1967, the conference was set for September 10, 11 and 12, 1967, at the University Tower Hotel, just off the campus of the University of Washington in Seattle. Within weeks following the approval of the grant, nine leaders in the fields under consideration were invited to prepare working papers for the conference. These papers were distributed prior to the conference since it was the intention of the convenor that the papers would not be read at the conference but short summaries



would be given instead and the major portion of time would be allowed for full discussion of each paper. A complete tape recording of the discussion sessions was made. From the transcription of the tapes, major points have been extracted for this Proceedings. These appear immediately following each of the individual working papers. Dr. Lester Asheim was unable to be present. At his request, Professor Dorothy Bevis of the University of Washington School of Librarianship read the Asheim paper. At the conclusion of Ralph Esterquest's paper, you will find an extension of his presentation in the content taken from the paper "Use of Non-print Media in Library School Instruction" prepared by Irving Lieberman for the International Conference on Library Education organized by the Library School at the University of Illinois in June 1967. This information seemed appropriate to the discussion at hand and the full paper was distributed to the conferees at Seattle. Several appendices, namely, the participants' biographical information, a selected bibliography on the subject of the conference, and other materials which would be pertinent to library educators and/or health sciences faculty in considering the establishment of appropriate programs for health sciences librarianship are included.

As convenor of the conference, I wish to make particular acknowledgment not only of the grant which made the conference possible but also of the outstanding cooperation and continuous support of Herbert H. Fockler of the Extramural Programs Office of the National Library of Medicine.

I would like to extend my thanks to the members of the local planning committee, of the faculty and staff of the University of Washington, for helping to develop the proposal for the grant and assisting in the selection of participants for the conference, as well as for attending the conference themselves. Planning committee members were: Miss L. Dorothy Bevis, Professor and Associate Director, School of Librarianship; Dr. Charles W. Bodemer, Chairman and Associate Professor, Biomedical History; Mrs. Marian G. Gallagher, Professor, Law, and Law Librarian; Dr. Henry N. Harkins, Professor of Surgery (Deceased); Dr. Irving Lieberman, Professor and Director, School of Librarianship; Mr. Gerald J. Oppenheimer, Head, Health Sciences Library; and Dr. Donal Sparkman, Coordinator, Regional Medical Program.

The editor wishes to express his appreciation for assistance in the preparation of this Proceedings volume to: Harris McClaskey, conference participant and former Director of the Hospital and Institution Library Program of the Washington State Library, now a doctoral candidate at the University of Washington; and to John J. Newman and Jerrold L. Tinker, graduate assistants in the School of Librarianship.

Irving Lieberman

January 1968

## PROGRAM

University Tower Hotel--Regency Room--4507 Brooklyn Avenue N.E.--Seattle, Washington

### SUNDAY, September 10

1 - 4 Registration - Mezzanine

4:00 Social Hour  
The Liebermans at home

6:30 Dinner - President's Room

8:00 FIRST SESSION:

#### THE CHANGING FACE OF MEDICAL LIBRARIANSHIP

Dr. Estelle Brodman, Librarian and  
Professor of Medical History  
Washington University, St. Louis

### MONDAY, September 11

8:30 SECOND SESSION:

#### THE RELATION OF SPECIAL LIBRARY EDUCATION TO GENERAL LIBRARY EDUCATION

Dr. Lester Asheim, Director, Office for Library Education  
American Library Association, Chicago  
(paper presented by Professor Dorothy Bevis  
University of Washington)

10:00 Coffee

10:30 THIRD SESSION:

#### MEDICAL HISTORY, LIBRARIES AND CURRICULA

Dr. Charles W. Bodemer, Chairman and  
Associate Professor, Biomedical History  
University of Washington, Seattle

12:30 Luncheon - President's Room

MONDAY, September 11 (continued)

2:00 FOURTH SESSION:

LEVELS OF PREPARATION REQUIRED FOR MEDICAL LIBRARIANSHIP

Dr. David A. Kronick, Librarian  
Medical Library, the University of  
Texas Medical School at San Antonio

3:30 Coffee

3:45 FIFTH SESSION:

CURRICULUM CONTENT FOR EDUCATION IN MEDICAL LIBRARIANSHIP  
AT SEVERAL LEVELS

Mr. Alan M. Rees, Director and Associate Professor  
Training Program in Medical Librarianship  
Western Reserve University, Cleveland

6:00 No-host Social Hour - Regency Room

7:00 Dinner - President's Room

8:30 SIXTH SESSION:

TRENDS IN THE HEALTH SCIENCES: IMPLICATIONS FOR MEDICAL  
LIBRARIANSHIP

Dr. Charles R. Strother, Professor  
Psychology and Psychiatry; Director  
Mental Retardation and Child Development Center  
University of Washington, Seattle

TUESDAY, September 12

8:30 SEVENTH SESSION:

EDUCATIONAL PROGRAMS FOR HOSPITAL HEALTH SCIENCE LIBRARIANS

Dr. Vern M. Pings, Medical Librarian  
Wayne State University, Detroit

10:00 Coffee

TUESDAY, September 12 (continued)

10:30 EIGHTH SESSION:

SYSTEMS CONCEPTS AND LIBRARY EDUCATION

Dr. Richard H. Orr, Director  
Institute for Advancement of  
Medical Communication, Philadelphia

12:30 Luncheon - President's Room

2:00 NINTH SESSION:

INSTRUCTION IN THE MODERN TECHNIQUES OF BIOMEDICAL  
COMMUNICATION

Mr. Ralph T. Esterquest, Librarian,  
The Frances A. Countway Library of Medicine, Boston

3:30 Coffee

3:45 SUMMARY



## LIST OF PARTICIPANTS

Dr. Lester Asheim, Director  
Office for Library Education  
American Library Association  
50 East Huron Street  
Chicago, Illinois 60611  
(not present)

Miss L. Dorothy Bevis  
Professor and Associate Director  
School of Librarianship  
133 Library  
University of Washington  
Seattle, Washington 98105

Dr. Charles W. Bodemer  
Chairman & Assoc. Prof., Biomedical History  
A225 Health Sciences  
University of Washington  
Seattle, Washington 98105

Dr. Estelle Brodman  
Librarian & Prof. of Medical History  
Washington University Library  
4580 Scott Avenue  
St. Louis, Missouri 63110

Miss Louise Darling, Librarian  
Biomedical Library  
The Center for the Health Sciences  
University of California, Los Angeles  
Los Angeles, California 90024

Mr. Ralph T. Esterquest, Librarian  
The Francis A. Countway Library of Medicine  
10 Shattuck Street  
Boston, Massachusetts 02115

Mr. Herbert H. Fockler  
Training Grants Officer  
Extramural Programs  
National Library of Medicine  
860 Rockville Pike  
Bethesda, Maryland 20014

Mrs. Marian G. Gallagher  
Professor, Law; Law Librarian  
310 Condon  
University of Washington  
Seattle, Washington 98105

Mr. Henry J. Gartland  
Director, Library Service  
Veterans Administration  
Department of Medicine and Surgery  
Washington, D.C. 20420

Mr. Paul Howard  
Executive Secretary  
Federal Library Committee  
The Library of Congress  
Washington, D.C. 20540

Dr. David A. Kronick, Librarian  
Medical Library  
The University of Texas Medical  
School at San Antonio  
715 Stadium Drive  
San Antonio, Texas 78212

Dr. Irving Lieberman  
Professor and Director  
School of Librarianship  
133 Library  
University of Washington  
Seattle, Washington 98105

Mr. Harris McClaskey  
Doctoral Candidate  
University of Washington  
5025 22nd N.E.  
Seattle, Washington 98105

Mr. George McDonough  
School of Librarianship  
133 Library  
University of Washington  
Seattle, Washington 98105

Mr. Gerald J. Oppenheimer  
Head, Health Sciences Library  
A318 Health Sciences  
University of Washington  
Seattle, Washington 98105

Dr. Richard H. Orr, Director  
Institute for Advancement of  
Medical Communication  
3401 Market Street  
Philadelphia, Pennsylvania 19104

Dr. Vern M. Pings, Medical Librarian  
Wayne State University  
School of Medicine  
Medical Library  
645 Mullett Street  
Detroit, Michigan 43226

Mr. Alan M. Rees, Director  
Medical Librarianship  
Training Program  
School of Library Science  
Western Reserve University  
Cleveland, Ohio 44106

Dr. William O. Robertson  
Associate Dean  
School of Medicine  
C304, Health Sciences Building  
University of Washington  
Seattle, Washington 98105

Dr. Donal R. Sparkman  
Coordinator, Regional Medical Program  
AA312 University Hospital  
University of Washington  
Seattle, Washington 98105

Dr. Charles R. Strother  
Professor of Psychology and Psychiatry  
Director, Mental Retardation and  
Child Development Center  
University of Washington  
Seattle, Washington 98105

Miss Helen Yast, Librarian  
American Hospital Association  
840 North Lake Shore Drive  
Chicago, Illinois 60611

## CONTENTS

Introduction: Irving Lieberman	iii
Program	v
List of Participants	ix
FIRST SESSION:	
<u>The Changing Face of Medical Librarianship</u> by Estelle Brodman	1
Points from the Group Discussion	13
SECOND SESSION:	
<u>The Relation of Special Library Education to General     Library Education</u> by Lester Asheim	15
Points from the Group Discussion	23
THIRD SESSION:	
<u>Medical History, Libraries and Curricula</u> by Charles W. Bodemer	25
Points from the Group Discussion	35
FOURTH SESSION:	
<u>Levels of Preparation Required for Medical Librarianship</u> by David A. Kronick	37
Points from the Group Discussion	47
FIFTH SESSION:	
<u>Curriculum Content for Education in Medical     Librarianship at Several Levels</u> by Alan M. Rees	49
Points from the Group Discussion	71

SIXTH SESSION:

<u>Trends in the Health Sciences: Implications for Medical Librarianship</u> by Charles R. Strother	73
Points from the Group Discussion	83

SEVENTH SESSION:

<u>Educational Programs for Hospital Health Science Librarians</u> by Vern M. Pings	85
Points from the Group Discussion	103

EIGHTH SESSION:

<u>Systems Concepts and Library Education</u> by Richard H. Orr	105
Points from the Group Discussion	123

NINTH SESSION:

<u>Instruction in the Modern Techniques of Biomedical Communication</u> by Ralph T. Esterquest	125
Points from the Group Discussion	145

Conclusion and Summary: Irving Lieberman 147

Appendix A -- Code for the Training and Certification of  
Medical Librarians 153

Appendix B -- Education and Training for the Veterans  
Administration Library Program  
by Henry J. Gartland 161

Appendix C -- Biographies of Participants 167

Appendix D -- A Selected Bibliography for the Conference on  
Education for Health Sciences Librarianship 213



**FIRST SESSION**

**THE CHANGING FACE OF MEDICAL LIBRARIANSHIP**

**By**

**Estelle Brodman  
Librarian and Professor of Medical History  
Washington University School of Medicine  
St. Louis, Missouri**

To be appropriate, education for a technical and professional calling must be geared not only to the immediate present, but even more so to the foreseeable future of at least half a generation beyond. While it may be hard to see clearly to the end of this half-life period, certain closer views are possible, and so I believe the planning committee was eminently correct in starting this symposium on education for medical librarianship by a discussion of what we can discern of medical libraries in the next ten to twenty years. And while I have no illusion that my crystal ball is any less opaque than that of others, perhaps it may be helpful to all of us in our discussions in the next few days if I recalled to your mind some trends and the dimly-seen changes on the horizon, which, by altering everyday life, medicine, and medical libraries, will alter the kind of education which we should be trying to impart to beginning medical librarians.

As I see it, there are nine elements which have meaning for what the next generation of librarians will be doing, and I find that they divide (in my mind, at least) into three groups. First are those things which affect us merely because we are citizens living in this country at this time in history; second are those patterns of medicine and medical care which are changing and which in turn will bring changes to medical libraries; and finally, there are the developments in medical librarianship itself which will have profound effects on what our successors do each day. Let me now examine these groups one by one. I understand that at the end of the papers there will be a period of discussion, where you may ask the speakers searching questions and the speakers will search around for appropriate responses.

#### Changes In Modern-Day Life

The first change in our modern world which I believe will have meaning for medical librarianship concerns the composition of our population. The National Planning Association has predicted that by 1975 nearly 73% of the nation's population will be living in urban areas, with 60% concentrated in the 25 largest metropolitan areas.<sup>1</sup> The year 1973 is only six years hence; by 1987 (which I suggest as the end date for the generation of librarians we are now educating) that average will probably have risen so that 85% of our citizens will be urban dwellers, with 75% living in the largest megapoli. I do not quite understand the suggested age distribution of these people in 1987; the peak of the increases in young people due to the birth of World War II babies appears to be passing, and whether the proportion of older or younger members of our society will change materially seems to me to be dependent upon factors not yet well understood--such as, will there be another war, and what actual effect will The Pill have on the family life of a decade hence? For this paper, I shall assume the age groups will be in pretty much the same proportion as they are now.

What will this do to medical libraries? To start with, we may expect that the older pattern of individual physicians responding to individual calls for help from individual ill people will have vanished almost entirely. The old-fashioned picture of the horse-and-buggy doctor or the town physician visiting his middle-class patients in their homes or seeing them at his central office, while poorer patients are sent to city charity

hospitals, and with the doctor performing all the duties of every medical attendant, will have become a thing of the past. (We have already gone a long way from that, of course; my father, who started practice in 1901, once told me when he first got out of medical school, he delivered babies, and then washed and dressed them, all in his patients' homes, and all for the fee of \$5 if the family was in normal economic circumstances, or \$10, if they were well-off. When our servant-girl became very ill, no one thought to send her to the hospital--she had been with us for many years and was almost a member of our family, and it would have been unthinkable to be so unfeeling as to let her die alone in a strange hospital!)

With large concentrations of populations in urban areas, I think we may expect to have much more group practice. A physician will no longer be the lone fighter warding off death and destruction from all sides by his own unaided efforts. He will be a specialist who will refer to other specialists in his group much more than we see today; or else he will be the internist or diagnostician, whose job it will be to integrate the findings of the other specialists with whom the patient comes in contact.

In this city-practice, many more patients will be sent to hospitals for lesser and lesser ailments, merely because it consumes less time for the physicians to see many patients in one place than to go from home to home. And the economic help given by Medicare, Medicaid, and all the other health insurance schemes will further intensify this; indeed, our society will probably find it cheaper to intensify this form of aid than to subsidize the physician through continuing his less efficient former ways. In spite of the statement by the present President of the American Medical Association that medical care is a privilege, not a right, the electorate (and most physicians, I believe) do not agree with this viewpoint. We may therefore expect to see more, rather than less, spreading of the cost of medical care throughout the populace and more individuals brought under the cover of such aid.

As a result of this trend, I see several changes in medical libraries. I believe that a more expert level of medical care will be offered by physicians who are specializing; they will have more time (because of the concentration of their patients in one place) for study and attendance at meetings and to shoptalk with other physicians. As a result, I believe that they will use medical libraries more than the average practitioner does today, and that they will wish to have more on specialized fields of medicine than they do today. Since essentially, however, they will continue to be busy practitioners, additional ways to pre-digest what it is being learned and to bring it to their attention more automatically and more quickly will be needed. What medical libraries purchase will therefore have to be different--both in subject matter and in form--and how it is packaged for use by the physician will have to be revamped. We will need medical librarians in the future, I believe, who can be experts in both the subject matter to a much deeper degree than at present, but who can also design and manipulate new systems of presenting the available information.

A second general effect of modern life which has an effect on medical librarianship is the form in which knowledge is disseminated. For the past 400 years or so, we have

grown accustomed to printed words on paper, bound in a codex form, each copy the same as all others, and remaining essentially unchanged once it is produced. Microfilm, microforms, and photocopies are essentially similar systems. This purely visual and essentially static form of publication is now being crowded (not necessarily crowded out, of course) by other forms which are auditory, rather than visual, and which change through manipulation by the user. Tape recordings, teaching machines, closed-circuit television, training films, and computers, both singly and in networks, are all with us today, and in my opinion likely to grow in usefulness, rather than wither away. How much listening rather than reading has become an educational tool and a way of life today is brought home to me every semester when I read the papers from my history of medicine class (composed of sophomore medical students) whose spelling is almost always phonetic and "simplified" to agree with how the words sound. The audiodigest tapes which physicians can now listen to in their cars, the EDUCOM-proposed network and the Project INTREX, and others like these will have profound effects on the way in which we build our library buildings, on the equipment we will need, and the kinds of staff we will have to find and train. The recent article by Dr. James Miller in the Journal of Medical Education,<sup>2</sup> in which he describes a biomedical communications building, where the Library is but one facet in an integrated system of all forms of communication, reveals many changes from the traditional architect's or donor's idea of what a library building should look like or contain.

Moreover, the material found in these new media are not forever the same, but in many instances, notably computer networks, are manipulated and changed by the user at will. What problems this will raise in determining how--or whether--to catalog or index such material are horrifying to consider. We may well be in the position of Alice in Wonderland at the croquet game, whose mallets were really flamingos which twisted and turned each time Alice prepared to hit the ball.

That I am not making this problem up as I go along is perhaps shown by the number of mergers between traditional publishing firms and computer companies. McGraw-Hill can stand as one example of the large number of such companies which believes that it will not be possible to conquer the computers, so it might as well join them. Libraries, and particularly medical libraries, need to take the same attitude, and we must prepare our students to handle the problems of such devices, which they will encounter more and more as time goes on.

The final topic in the general field which I should like to call to your attention today is the matter of copyright. The new copyright law which is being discussed in Congress and has already passed through the House, may change the methods of medical libraries rather drastically. In a recent article in the AAUP Bulletin<sup>3</sup>, the threat was made that the difficulties inherent in the proposed copyright law for educational institutions may turn out to be so great that these institutions will end up by foregoing the use of copies. The author continues by pointing out that while learning and teaching will deteriorate under these circumstances, neither will the author or publisher gain through increased sales. I do not think this situation will occur in medical libraries, where the making of copies has become so much a way of life that it would take more than nuisance and cost to



curtail it. But it may become more expensive--in time of personnel to keep records, to obtain clearances, and to account fiscally to the proper authorities. It will then be necessary for medical libraries to rethink their present ideas about circulation by copies, both locally and for interlibrary loans, whether the loans are photocopies or sent as loans via long-line telephone lines, computer networks, TWX, or long-distance xeroxing. Newly trained librarians must be given some idea of cost-accounting, experimental design, and the way to obtain the names of good lawyers, I am afraid.

### Changes In Medicine

Up to now, I have been talking about the effect on medical libraries of changes in the world about it. Now I should like to discuss some of the changes in medicine itself, which I believe may change medical librarianship in the next ten to twenty years.

The first of these changes, Medicare and Medicaid, I have already mentioned. Other federal and local laws, however, have at least as much impact as these. For example, to my way of thinking, the Heart Disease, Cancer and Stroke Regional Centers have a potential for changing medical practice through medical research and medical teaching as no other single legislative act in the past generation may have done.

The purpose of the Medical Center Act, as stated in the report of the Heart Disease, Cancer and Stroke Commission to the President is to see that what is known is brought to the attention of the practitioner at the bedside. The exact words used were, "The forward sweep of medical science has brought about a kind of 'instant obsolescence' in medical knowledge...it poses a critical obstacle to the delivery of up-to-date health care. Therefore, a systematic nationwide program of continuing education for physicians is a categorical imperative of contemporary medicine.... The gap between what is known and what is received by patients will be harder and harder to bridge."<sup>4</sup>

The program envisions a series of centers which will conduct research on the diseases under study, and teach physicians in the geographical area the results of this research in order that patient care can be improved. The general practitioner outside the orbit of teaching hospitals today and the specialist in the group practice consortia of the future, which I described earlier, will be educated continually under this system, and the medical library can be an important means for strengthening and deepening both the research and the teaching functions, and thus ultimately the patient care. It can do it in two ways: by waiting passively for the increased use which the setting up of these Centers will bring, especially as they go on from heart disease, cancer, and stroke to other disease entities; or they can play a dynamic and even aggressive role in bringing the knowledge that has already been recorded to those who need it. At the last meeting of the Medical Library Association, Dr. Margaret Sloane, in charge of these Centers, spoke eloquently of the place of the medical library in such efforts.<sup>5</sup> We must see to it that new medical librarians have an understanding of what these Centers are trying to do and how libraries can help. Since this is still a new field, bold imagination and innovative powers will help, of course, but already we know some of what can be done, and we should see to it that students in our field are exposed to these ideas.

Still another change in medicine is a result of the planning for additional medical, dental, nursing, etc. schools under several health sciences assistance acts. Each of these schools will need and will try to establish new and extensive libraries; yet the collection of a library today is vastly different from what it was only a generation ago. The number of items to be obtained, the difficulty of finding the material in original form, the tremendous cost which inflation and scarcity have brought with them, will all make the foundation of a new medical library a different matter from that obtained in the past. Let me give you just one example. When the Washington University School of Medicine was reorganized as a result of the Flexner Report in the 1910's, the then Library Committee made a rule that when they purchased a journal title they would go back and obtain it from volume one number one to the date of the current subscription.<sup>6</sup> This has given us a medical library collection which is tremendous in its sweep of material, but I am convinced that it could not be done today, even with almost unlimited amounts of money. How many complete sets of the Philosophical Transactions of the Royal Society from the 17th century to the present are available for sale today, or the Memoires of the French Académie de Médecine, Bartholinus' Acta medica et philosophica Hafniensia or the Acta Leopoldiana?

Since this is so, new medical libraries are going to have to depend either upon reprinted versions of older works--and these may be paper reprints, or produced on microfilm or microfiche--or be prepared to enter into some kind of relationship with another library for paid interlibrary use of material not available locally. The concept of meum and teum, as practiced by libraries in separate institutions in the past, is going to be modified during the lifetime of medical librarians now in school.

I have left to the last, in my discussion of the effects of new laws on medical librarianship, the matter of the Medical Library Assistance Act. In some areas this Act has already had a great impact, and will continue to have even greater force. In others, however, the Act has promised much and given comparatively little, partly due to the lack of funds and partly due to the need for people with bold imagination and the ability to persuade a reluctant Congress and even more reluctant librarians; a need which the National Library of Medicine shares with many other institutions. Where this Act has been most important, to my way of thinking, has been in the provision for educational opportunities for medical librarians. Here I believe it has used imagination and shown a willingness to try out new and differing ways to reach a common goal. Moreover, education is the seed of the future, and by investing in it, the National Library of Medicine has taken the long view, as well as making provision for upgrading the present situation.

Where it has been less successful, again from my personal viewpoint, is not in providing money for new buildings, which is, after all, a result of Congressional feelings about capital expenditures in time of war, but in its emphasis of resources. So long as the staffs needed to exploit these resources are in short supply and are ill-prepared to use such resources to the best advantage, perhaps it would have been better to put more emphasis on other portions of the program--research, for example.

Whether we quibble with one or another portion of the handling of the Medical Library Assistance Act, however, there is no doubt of its importance and the enormous effect

it will have on the next generation of medical librarians, who will come to better libraries better prepared to make them more useful to society. If it has done nothing else, it has given medical librarians one aid program pointed directly to them, and not sandwiched in among other institutions and programs. What effect this has had on morale is a talk all by itself!!

In addition to federal aid to medical libraries and the impact that it will have on medical librarianship in the next decade, there are changes being wrought by the way in which medical research is conducted. Because so much of this research is not connected with pre-clinical fields, such as biochemistry, and employs team approaches to problem-oriented investigations, the kinds of people who use the medical library and the training and background they have had are undergoing changes, which will intensify in the future. The types of indexes which a biophysicist or a bioelectrical engineer uses in his work vary considerably from those the practitioner of medicine tends to cultivate. They are arranged differently; they may more likely be on tapes or microfilm, or be produced on cards or other storage devices, and they are almost uniformly much more expensive. As they have developed more cross-ties with medicine, the need for tools which could coordinate the several fields and divide up all knowledge from a different axis than had been common in the past will produce still another layer of indexes to knowledge, which the medical library will have to obtain. These will not only be very expensive, but they will require librarians trained in new techniques to find their ways about them. The output of the Chemical Abstracts Service firm<sup>7</sup> is a sample of what I think the medical library will more and more deal with in the future.

With the subject matter of medicine changing under our very eyes, and with the kinds of people who will be using our collections varying more in the future than in the past--due in part to specialization and hierarchical configurations of medical attendants mentioned--we will have to train medical librarians in a wider variety of tools and methods than they had to cope with in the past. After all, when nurses' aids and genetic molecular physicists all use the same medical library, the librarian will have to be more things to more people.

#### Changes In Librarianship Itself

Finally, now, I come to the changes which librarianship itself will bring about in the subfield of biomedical librarianship. These I should like to discuss under the headings of: computers, machine-readable centrally-produced catalogs and indexes, and staff shortages, although obviously there are many more topics which could be discussed. Then, you will be happy to know, I shall be done.

Computers. The question which used to be asked about computers and libraries a short five years ago--whether they would find a place in librarianship--has changed completely to how and when they will be used. Certain facets of the work of libraries have been almost standardized for computer manipulation, and there is almost no medical library above a certain size which either is not using such machines in one form or another or is not studying the methods in use to begin their operation in the near future.



The record-keeping, especially the fiscal accounting, and often the inventorying of the collection (that is, the circulation system), have most often been successfully attacked. Serial records are increasingly being kept on computers and printed catalogs from computer stores becoming increasingly common. Even in the fields of the storage and retrieval of information and bibliographic data, headway is being made.

These uses of computers will continue in libraries, but they represent only the swaddling clothes stage of such work. For the most part, they are individual institutions and unstandardized, as would be expected in a new and widely growing field. But it is obvious that this wild growth cannot continue, and we may expect to see more thought being given to joint efforts to solve some of the problems in a standardized and compatible way. The existence of computer networks demands this; the economics of each institution's doing over again the same or similar work as every other institution, in a period where rapid communication is possible, is open to serious question. We have already seen the work of EDUCOM in convening a meeting this past July to discuss just this question, and whether their ideas or the ideas of another group prevail, the basic notion of standardization will have to be accepted. This means that libraries will need to give up their local autonomy for the advantages of joint effort, and we will have to inculcate into the medical librarians we train the idea that nothing is sacred merely because it has always been done that way, and that there is virtue in the prayer coined by my library staff, "Good Lord, keep us from doing efficiently what doesn't need to be done at all."

As medical librarians use computers for ever-enlarging groups of tasks the question as to who will control the operations of the machine will have to be reconsidered. A library which now uses a computer set-up in another portion of its institution is inso facto unable to direct when and how that computer will be used. (When the payroll checks or a report to the President needs to be made, where do you suppose the Library's work will be put? It turns out that even Project MARC at LC faces this problem.) I believe that fairly-large medical libraries of the future will almost certainly have their own computers; under their own jurisdiction, even though such computers will be smaller, slower, and older than the ones in the central computer center, on which the medical library may well draw for the larger, less frequent jobs, such as printing its book catalog.

It goes without saying, of course, that future medical librarians will have to know much more about machines than is common these days. Of course, we will teach them this in library schools and elsewhere. But this will have effects on the people who go into the field. We may expect to find many more men opting for medical librarianship than in the past, since (feminist though I am) I believe there is generally a sex-linked ability to handle machinery. Machinery will appeal to the men and in turn will tend to turn away the average woman, who will only be able to manipulate the computer--much as most women do their automobiles today--with little real understanding of what makes it work and almost no ability to tinker with it when it is not going well. I believe this will also have some bearing on salaries and on the status of the librarian within the institution, and I can only hope that those of us who grew up under other circumstances do not



resent the new situation or drive out the eager younger man under us by stultifying work experiences. A course for older librarians in the psychology of intellectual aging might well be a part of the continuing education courses offered by the Medical Library Association!

Machine-readable indexes and catalogs. The pioneer work in producing machine-readable indexes to any segment of the literature was probably that of MEDLARS, but it had somewhat less impact on the practice of medical librarianship than might have been expected because one of its most important products appeared in traditional printed form and did not require medical libraries to change in any way in order to use it. The MEDLARS substations and the MEDLARS demand searches have also produced less change than might have been expected because they were too few in number to be the normal experience of most librarians. On the other hand, Project MARC at the Library of Congress had designed into it the provision of machine readable copy to libraries on a wide scale, and by this very fact, it caused the National Library of Medicine and the National Agricultural Library to consider joining in the same venture.<sup>8</sup> Even commercial firms, such as Stacey's, are beginning to get into the act, by offering computer catalogs for the books it sells each library.<sup>9</sup>

It is obvious from this that medical libraries in the future are very likely to obtain their cataloging information in a form which can be put on a computer as well as in a form (sent directly from Washington or derived locally from the machine output) which is close to or the same as traditional forms. It is my feeling that this will join with the impetus given medical librarians by commercially produced computer indexes, which I mentioned earlier, to make medical librarians use computers in different ways from those they are accustomed to today, and will make them use them so often, computers will become as much a part of their being as the xerox machine or the telephone. Consoles and display screens will surely be available in many places, including offices of faculty members, research staff, and practitioners, (placed there often for other than library reasons), and it may be that real-life visits to the library will give way to remote interrogation of the library's contents to a greater and greater extent. What change this will have on the number of seats, desks, carrels, and ashtrays which must be provided in new medical library buildings is a question, of course, and how library staff members will react to such a non-human environment is another moot question.

Staff shortages. This brings me logically to the last portion of my discussion; namely, the shortages of library personnel which medical libraries have been experiencing.

One of the changes which have been going on throughout our society is a trend away from blue-collar work toward white-collar work. The last census of the U. S. labor force showed that for the first time in the history of our country more of our laboring population were engaged in service occupations than in manufacturing and farming combined.<sup>10</sup> To put it another way, the people in this country now appear to live by taking in each other's washing!

Since there is now no backlog of struggling physical laborers who wish to move upward in the scale of remuneration and status into clerical and professional jobs, all newly emerging operations which require additional help must obtain them from the present white-collar laboring force, and this robbing of Peter to pay Paul has resulted in shortages of personnel in all classes of jobs. Medical librarianship, as a burgeoning field, must expect to find the same situation, and it behooves everyone to make provisions for what the future will bring. It will be necessary, I believe, to accept what we now consider shortages as the normal course of life--it may, indeed, get worse rather than better, and we will find ourselves, like Aeneas, sighing, "Forsan et haec olim meminisse juvabit," ("In the future, even this may look good in retrospect.")

It seems to me that medical librarianship in the future will have to examine the tasks which it has traditionally done; sort out those which it still feels necessary for its mission, discard the others, and add the necessary new ones to this group. Of the necessary tasks, it will again have to make a sort of the steps within each task, to determine which of them can be done with untrained, poorly trained, and unintelligent, unwilling help. Libraries, like other parts of society, are going to have to use drop-outs, the culturally disadvantaged, the ignorant, the unmotivated, and those without too much capacity to learn.

But by rearranging the tasks and structuring the work to the laborers we can obtain, I believe medical librarianship can see to it that more people in the future who do have the capacity and have learned the methods and the theory behind them can practice this higher level of intelligent work more often than at present. And, as I have said so often in the past that I seem to be repeating myself endlessly, I believe medical librarianship may then be able to attract to its ranks the better thinkers of the society we represent, and with these people can soar to heights not yet attained...But this is the domain of another of our speakers, and I will not encroach further.

### Conclusions and Summary

The nine problems I have discussed in this paper represent the items which I believe will change the face of medical librarianship in the next generation. They include: (1) shifts in population in the next 20 years, (2) concomitant changes in medical practice, (3) newer methods of publication, (4) copyright revisions, (5) new federal legislation affecting medicine, (6) modification in medical research methods, (7) development of computer technology, (8) machine readable indexes and catalogs, and (9) personnel problems. All are important; taken singly or all together, and a study of them may give us some insight into the world of tomorrow for whose benefit we are educating the students in medical librarianship today.

## REFERENCES

- <sup>1</sup>St. Louis Post-Dispatch, July 10, 1967, p. 3A.
- <sup>2</sup>James G. Miller, "Design for a University Health Sciences Information Center," Journal of Medical Education, XLII (May, 1967), 404-29.
- <sup>3</sup>John C. Stedman, "Copyright Law Revision: Its Impact upon Educational Activities," American Association of University Professors Bulletin, LIII (June, 1967), 126-32.
- <sup>4</sup>President's Commission on Heart Disease, Cancer, and Stroke, A National Program to Conquer Heart Disease, Cancer, and Stroke, Report to the President (Washington: U.S. Government Printing Office, 1964), I, p. 19.
- <sup>5</sup>Margaret Sloane, "Implications of Regional Library Planning. Relationships with Regional Medical Program Planning," Speech at 66th Annual Meeting, Medical Library Association (Miami, Florida, June 13, 1967).
- <sup>6</sup>Washington University. School of Medicine. Unpublished Minutes of the Library Committee, St. Louis, Mo.
- <sup>7</sup>a. Chemical Biological Activities (CBAC), a publication of the Chemical Abstracts Service.  
b. Preparation of Search Profiles; A Guide to the Effective Use of CAS Services on Magnetic Tape (Columbus, Ohio: Chemical Abstracts Service, 1967), 41 pp.
- <sup>8</sup>Library of Congress Information Bulletin, XXVI (June 29, 1967), 407-408.
- <sup>9</sup>The World of Tomorrow--Today! (Palo Alto, California: Stacey's Scientific Book Center, 1967), 11 pp.
- <sup>10</sup>Seymour L. Wolfbein, "Nature and Causes of the Library Manpower Shortages," Speech at 86th Annual Conference, American Library Association (San Francisco, California, June 25, 1967).

Since there is now no backlog of struggling physical laborers who wish to move upward in the scale of remuneration and status into clerical and professional jobs, all newly emerging operations which require additional help must obtain them from the present white-collar laboring force, and this robbing of Peter to pay Paul has resulted in shortages of personnel in all classes of jobs. Medical librarianship, as a burgeoning field, must expect to find the same situation, and it behooves everyone to make provisions for what the future will bring. It will be necessary, I believe, to accept what we now consider shortages as the normal course of life--it may, indeed, get worse rather than better, and we will find ourselves, like Aeneas, sighing, "Forsan et haec olim meminisse juvabit," ("In the future, even this may look good in retrospect.")

It seems to me that medical librarianship in the future will have to examine the tasks which it has traditionally done; sort out those which it still feels necessary for its mission, discard the others, and add the necessary new ones to this group. Of the necessary tasks, it will again have to make a sort of the steps within each task, to determine which of them can be done with untrained, poorly trained, and unintelligent, unwilling help. Libraries, like other parts of society, are going to have to use drop-outs, the culturally disadvantaged, the ignorant, the unmotivated, and those without too much capacity to learn.

But by rearranging the tasks and structuring the work to the laborers we can obtain, I believe medical librarianship can see to it that more people in the future who do have the capacity and have learned the methods and the theory behind them can practice this higher level of intelligent work more often than at present. And, as I have said so often in the past that I seem to be repeating myself endlessly, I believe medical librarianship may then be able to attract to its ranks the better thinkers of the society we represent, and with these people can soar to heights not yet attained...But this is the domain of another of our speakers, and I will not encroach further.

### Conclusions and Summary

The nine problems I have discussed in this paper represent the items which I believe will change the face of medical librarianship in the next generation. They include: (1) shifts in population in the next 20 years, (2) concomitant changes in medical practice, (3) newer methods of publication, (4) copyright revisions, (5) new federal legislation affecting medicine, (6) modification in medical research methods, (7) development of computer technology, (8) machine readable indexes and catalogs, and (9) personnel problems. All are important; taken singly or all together, and a study of them may give us some insight into the world of tomorrow for whose benefit we are educating the students in medical librarianship today.



## THE CHANGING FACE OF MEDICAL LIBRARIANSHIP

by Dr. Estelle Brodman

### Points from the Group Discussion

---

1. It is important for health sciences libraries to apply data processing to their operations as well as to learn where data processing is not feasible. Currently, most such applications are in the planning stage. Once computers are standardized, will it be essential for librarians to understand the mechanics of computer operation?
2. Indications point to computer services being made available as public utilities. It can be anticipated that computer time will be a public utility in ten to twenty years. It will be possible for libraries to connect with a national system comparable to existing telephone systems, without necessarily knowing what machines are used or who controls them.
3. Health sciences libraries in particular will be hurt by restrictions imposed by copyright legislation. Hopefully, the educational and scholarly communities will protest restrictions which are against the public interest.
4. Is it possible in any educational program, technical or professional, to prepare for the future? Library educators don't know what kind of position the student will accept, or what kind of an environment or administrative situation he will encounter.
5. Students should be taught to adapt to the evolving field of health sciences librarianship. This involves the teaching of adaptability, the ability to perform in changing situations. It is possible to predict future developments by projecting trends. It is necessary to teach librarianship as an evolving profession with discernible trends.
6. Students must develop the ability to adjust to a rapidly changing, dynamic situation. We need a tangible body of material to teach now which can build significance for the future. A curriculum concerned with problem solving, taught in a meaningful context, is one effective means of teaching adaptability.

SECOND SESSION

THE RELATION OF SPECIAL LIBRARY EDUCATION TO GENERAL LIBRARY EDUCATION

By

Lester Asheim  
Director, Office for Library Education  
American Library Association  
Chicago, Illinois

→

The other speakers in this Conference will be concerned with special education for Medical Librarianship as such. My assignment is to speak about education for librarianship in its more general context. And, because of my present position as Director of ALA's Office for Library Education, I suppose that I am also seen as a kind of representative of the Establishment - that, indeed, I'm expected to outline all the conservative and traditional objections to the innovative, experimental or revolutionary ideas that most of you would like this Conference to express. Could be. Conservatives always imagine themselves to be rational, sound and sometimes even liberal, and I am probably not the best judge of my own relative position along the continuum from radical right to radical left. I like to think, however that my comments may be less reactionary than you expect them to be.

First, let me state one bias of mine which may confirm your worst fears. It is my belief that education for medical librarians is a specialization within library education generally - and not a completely separate program of education. I do not deny the need for many courses specifically meant for the medical librarian - as a course in Storytelling is specifically meant for the school or children's librarian - but I am convinced that certain basic concepts, theories and techniques are essential for all librarians, and that the special librarian in any field - whether it be subject specialization or specialization by function - is a less effective special librarian if his whole approach is narrowed down too specifically to a concentration on the matter which happens to fall within a delimited definition of his special field alone. To quote a favorite aphorism of mine, from John Stuart Mill: "Men are men before they are lawyers, or physicians, or merchants, or manufacturers" - or, let me add, librarians - and they must be educated as men before they are trained to a profession. The narrowly trained librarian who is not an educated man or woman is not, I think, what most of us here are hoping to turn out of the Medical Librarians' Program under discussion.

On the other hand, all of the professions today are faced with the need for greater and greater specialization. Both librarianship and the health sciences face this necessity. Thus the health sciences turn to librarians to provide one kind of special expertise which will help them reach their goals. But as the health sciences field becomes broader and more complex, the outside specialists (be they librarians, social psychologists, systems analysts, whatever) are expected to specialize in specifics within the health sciences field as well as in their primary field. So the special training of medical librarians must be recognized as special, even by an advocate of the generalist approach like myself.

The challenge to the traditional programs of library education which is represented by this development seems to me to call for innovation rather than to inhibit it. If the best of both the general and the specialist programs is to be preserved, it can be preserved only through new approaches to both aspects. It is not safeguarded by the unintegrated addition of one or two specialist courses, tacked on to existing programs which do not assimilate the new material and relate to it. In other words, a job of rebuilding is required, and not just the patching of a few holes. I cannot but believe that the rebuilding approach will benefit all of library education, and not merely that aspect of it related to medical librarianship.

At this point, it is only natural for you to ask to what extent the existing machinery of the Establishment is geared to this high-sounding hospitality to innovation and change. That machinery is represented, of course, by the official Standards for Accreditation and the process of evaluation administered by the Committee on Accreditation. Although a special program in Medical Librarianship offered within an accredited school need not seek the approval of the Committee on Accreditation, the ideals represented by the Standards do suggest the touchstone by which the general quality of a new program would probably be evaluated by the Establishment. Those Standards are extremely general, and are based upon a concern that graduate education for librarians be taken as seriously and be treated as well as are any of the other disciplines and subject areas on the same campus. Thus they assert that the program of library education should be an integral part of the parent institution, assured of status and continuing financial support sufficient to carry out a graduate-level program; that the parent institution must give evidence of genuine interest in the program of library education and of intention and ability to provide continuing financial support sufficient to develop and maintain professional education; that the faculty shall be adequate in number, authority and competence to determine and to carry out a program designed to achieve professional and educational objectives; that the curriculum should be animated by a sense of purpose through emphasis on the significance and functions of the subjects taught, should stress understanding and ability to apply basic principles and methods, should keep abreast of current trends in library development and professional education, and should stimulate continuous professional growth; and that in the admission of students, the library school should give primary consideration to intellectual strength, personal balance and adjustment, aptitude for library service, and promise of professional purpose and development, but should reserve the right to interpret admission requirements in favor of the occasional applicant of exceptional ability who may not meet the formal requirements of the parent institution.

These standards seem to me to be broad enough to permit the greatest latitude to any educational institution seriously interested in providing quality education for librarians, yet there is a widely-held opinion in the library profession that the accrediting standards and procedures are a straitjacket against innovation, and that any library educator who breaks out of the traditional pattern will be punished by the withholding - or the withdrawal - of the Seal of Approval: Accreditation. This, incidentally, is the tone of the criticisms voiced against the accrediting bodies in every professional field, not only that of librarianship. And it is in direct conflict with the self-image held by the accreditors themselves, who see their function to be, not the rote imposition of inflexible standards, but rather the pursuit and promotion of excellence. Where, between these extremes, does the Truth lie?

As is usually the case, the Truth does lie somewhere between the two extremes. If the accreditors are guilty of hiding behind the Standards as their way of avoiding the new and the experimental, the educators are equally guilty of blaming the accreditors for their own failure to introduce new ideas and try new approaches. I must say that I do not know of any exciting new patterns in library education that have been slapped down by the Committee on Accreditation - but then, I do not know of many exciting new



patterns in library education that the schools have introduced. Perhaps this Conference can come up with one with which to put the accreditation process to the test. If it truly proves to be a challenge, it can only be beneficial to both sides of this alleged conflict.

There are, of course, certain incontrovertible facts. If there is to be accreditation of professional education at all - and let me assume for the moment that a profession does want some control over the education which qualifies its members - then there must be some kind of standards. And as soon as there are standards, there is bound to be a point at which certain programs must be said not to meet those standards. All of our education operates on this principle: from elementary school on, there are always some students who flunk out; some applicants for admission who do not have the prerequisites; some teachers who just do not provide the learning experience that justifies their retention. If there is any criticism of our educational process, it is not that standards exist, but that they are not stringently enough applied: that we flunk too few, admit too many who are unqualified, permit the poor teacher to continue too long. The one time that the Standards are seriously questioned is when a crisis situation arises - like the present shortage of professional personnel. At such a time there will always be some who suggest that standards be lowered in order to permit a greater number of persons to get by. It is usually a quantitative rather than a qualitative evaluation - and again I am assuming that this Conference is concerned about the quality of the medical librarians it educates, and not merely about the number of bodies that can be given some kind of union card to permit them to do a mediocre job in medical libraries. If I am correct in my assumption that the aim is to turn out better medical librarians as well as simply more of them, then some kind of standards are required (although not necessarily those we now have); and those standards, no matter how flexible or how strict, will continue to disqualify some programs and impose some requirements on those that are approved.

Given the fact that accreditation must always be handled by human beings, we can expect occasional human failures I suppose, in the application of the standards to the evaluation of a program. Certainly we can always anticipate that the judgments will occasionally be disputed by other human beings, especially by those against whom a negative decision has been made. However objective and quantitative the major measurements are, the application of the standards is, in the final analysis, a subjective process, vulnerable always to the inexactness of human judgment. So there will always be some dissatisfaction with any process that applies standards, and bases any kind of approved status upon them.

Whether the standards are realistic; whether they really guarantee quality - that is another matter, and one that plagues all education in any field and at every level. I predict that you will find this to be one of your biggest problems in this Conference: to decide what content at what level in what amounts and under what circumstances will supply you with the kind of person you want. And even more difficult, the need to devise a measuring stick which will make it possible for you to determine that you have indeed accomplished your objective.

It is my hope that the existing standards will not hamper you in your plans, although it is possible that some of them will seem to do so. The first point that is always brought up by any specialist field that seeks to establish a single-purpose program is the accusation that the present standards do not permit the accreditation of single-purpose programs. While this may be true in a sense, it is not completely true. The COA is on record stating that "a single-purpose library school may indeed satisfy the Standards for Accreditation (1951) provided that such a school gives evidence of a strong general program of library education which the standards prescribe." To the extent that the particular program under discussion here will be part of the general program of an accredited library school, it cannot possibly jeopardize the school's accredited status, unless it results in the deterioration of the faculty, curriculum, facilities and support of the general program of the school. That this shall not happen is the responsibility of the faculty and administration of the school itself, and there seems to be no reason to imagine that the recommendations of this conference should in any way be weakened out of fear of such an eventuality. To the extent that the special program is designed for an agency whose sole purpose is the preparation of medical librarians, the absence of a basic program of general library education might well be seen as a serious weakness.

It is only natural that accreditation for the profession require an overall view of the educational program under review rather than a narrow and specific one. Thus, in its evaluation of library schools, the COA looks primarily at the basic general program, and only then at its special programs. We do not feel - and I do not think you would wish us to alter this view - that a good library school should be denied accreditation because there are some weaknesses in one of its small special fields. Nor do I think you feel that a library school, however good it may be in turning out public, school, and university librarians, should not be accredited because it does not have a program for the training of map librarians, or archivists, or area specialists in Middle Eastern Studies - or medical librarians. In other words, accreditation is concerned with the basic program; in effect, the special programs provide additional pluses in the total evaluation, and should be encouraged, but they are not the crucial key to success in gaining accredited status. Surely you would not urge, I trust, that a school which does not give a good basic introduction to librarianship should be accredited merely because a couple of its special courses are very good.

To a very great extent, this insistence on a general basic curriculum rather than a series of specific special programs reflects a harsh aspect of reality, which is that no matter how specialized the interests and training of a student may be, he frequently accepts a position in another kind of library upon his graduation. For that reason, we feel it essential that all librarians know something about the profession of librarianship, and not merely about cataloging, or school librarianship or the bibliography of the biological sciences. For it can be reliably predicted that a certain percentage of these highly specialized graduates will go into acquisitions work rather than cataloging, into a university library rather than into an elementary school, into an art and music department rather than a medical library. The school cannot forbid its graduates to take positions for which they are unprepared, although it can advise strongly against it. The decision

rests ultimately with the employers, over which neither the schools nor the Committee on Accreditation have any control. And so the Committee on Accreditation has resisted the suggestion that there be specialized schools separately accredited for each separate aspect of library work, at least until there is more evidence than present experience can provide that this would indeed improve the quality of service to library users.

There is another and maybe even more important justification for this insistence upon a strong general base to backstop specialization. Few special librarians, no matter how highly specialized their libraries and their clientele, are limited in their service to the specific subject matter of the narrow specialization, nor completely independent of the collections and services of other libraries. The best special librarians cooperate constantly with other librarians, refer to other collections and other tools not available in their own libraries, and are deeply involved with the developments that affect librarianship generally. Surely the medical librarian is not immune from the effects of federal legislation related to training of librarians, to postal rates, to copyright regulation, to international exchange of materials, to censorship. He may get by with a nearsighted focus upon his own special field, but once again I am assuming that this Conference is interested in the education of librarians who will do a lot more than just get by.

Finally, many of the aspects of library training which are being specifically pinpointed in this conference as essential to the preparation of medical librarians are not unique to that specialty. The use of audio-visual aids, television, and other forms of communication; the adaptation of new technology to information retrieval, technical processes, and other library operations; the concepts of systems analysis - these are part of the training of all librarians, not just medical librarians. There are special adaptations no doubt, and some special tools peculiar to the field, but the general principles, theory and techniques should be in the background of all librarians, and will be better taught if they are not splintered into small aspects for each possible adaptation. It is my hope that you are for better education for all librarians, including medical librarians but not limited to them, for as I indicated earlier, no librarian is an island. Unless all libraries are made better, medical libraries can do little to improve their total service, short of becoming general libraries themselves in order to be prepared to meet any kind of request for library service that may arise. In that case, you are back to general library education, and there is little need for this conference.

What is highly special, of course, is the subject matter of the field of the health sciences; subject matter which lies outside the scope of the library school to supply through its own courses and its own teaching faculty. In the design of any program for the preparation of a librarian in a special subject field, room must be made for the student to gain the knowledge of that field through the subject divisions and departments. The library school may make such knowledge a pre-requisite for admission, or a concurrent part of the program leading to the degree, but in most cases the course work covering it should be offered outside the school by the masters of the subject. Although there is much to be said for a course in the literature and bibliography of the Biological Sciences taught in the library school, I am opposed to watered-down courses in "Biology for Librarians." After all, the medical library is to be organized and administered for



use by members of the medical profession, not by librarians, and those responsible for organization and administration should be familiar with the content from the inside. While the Medical Librarian probably need not be a fully qualified M.D., he should ideally be the equivalent of an M.A. in the field of the Biological Sciences.

In the area of the library specialty the emphasis, in the Standards, is on general principles rather than on specific details of content or quantity. This is deliberate, and while it may sometimes result in a certain intangibility and vagueness, it does promote the freedom that more quantitative and absolute standards would destroy. The COA does not feel that it lies within its authority to dictate what courses should be taught, in what sequence, and with what content. It feels that it cannot interfere with the internal administration of a university by saying that there must be a certain number of square feet per student, a certain percentage of Ph.D's on the faculty, a specific administrative organization imposed from outside. The selection of material for presentation, the amount and kind of it in relation to other specialized content, the reorganization, re-titling, and elimination of courses is for the individual school to determine. Freedom to experiment is essential to the improvement of library education, and improvement of library education is the goal of the COA as I hope it is of the schools. The responsibility for innovation rests, as it should, with the faculty and administration of the school, and not with a central office in Chicago.

Standards need not - should not - mean standardization. The accreditation standards of the ALA, therefore, define a floor but not a ceiling, and that makes the sky the only limit on the quality beyond the minimum standard towards which you are free to aspire. If this Conference concentrates on the best that it can reasonably achieve rather than on the least that it can get away with, you will find that the entire profession - including that arm of it that is charged with accreditation - is on your side.



THE RELATION OF SPECIAL LIBRARY EDUCATION TO GENERAL LIBRARY EDUCATION  
by Dr. Lester Asheim

Points from the Group Discussion

---

1. Special libraries are, after all, libraries.
2. The management skills and creative direction of a health sciences librarian are derived perhaps 90% from general preparation and 10% from special preparation. Library education has the responsibility to identify the 10% and to determine where and at what levels it fits into the total curriculum.
3. The faculty must instill course content with the philosophy, principles and theory which are fundamental to library education.
4. Is education for health sciences librarianship a specialization within library education generally?
5. It is crucial to recruit students with backgrounds appropriate to health sciences librarianship. Meanwhile, we should provide opportunities for those who do not have strong subject backgrounds to strengthen their subject knowledge regardless of whether this contributes to a degree objective.
6. A number of medical schools are considering the possibility of educating students in health sciences communication. These schools are not equipped to do this independently and should utilize existing library education resources. Does this concern on the part of medical schools imply shortcomings in the existing system? It is important that a substantial part of the education of health sciences librarians be conducted in the environment where the individual will spend his professional life.
7. Should library education provide flexible curricula which will accept individuals with varying preparation and goals, and tailor programs to meet their individual needs?

THIRD SESSION

MEDICAL HISTORY, LIBRARIES AND CURRICULA

By

Charles W. Bodemer  
Chairman and Associate Professor  
Department of Biomedical History  
University of Washington  
Seattle, Washington

The biomedical historian is a hybrid beast. The Chimaera of Greek mythology was a tripartite monster, its forepart a compound of lion and goat, its hindpart dragon; the professional medical historian represents a comparable intellectual compound of science and history and a third component which may be, to mention a few possibilities, anthropology, bibliography, classics, economics, linguistics, psychology or sociology. The historian of the medical sciences is not such a compounding because of some form of academic teratogenesis or intellectual schizophrenia, but because his subject straddles a great many scientific and non-scientific disciplines. As a consequence of the breadth of his field and his interests the medical historian may come into contact with diverse groups and he may provide a kind of bridge, linking not only the present and the past, but many apparently dissimilar elements in the university and the community. It is true that he may appear to some as a quaint antiquarian, mumbling obscure Latin titles and esoteric interpretations of past human events. It is true also that to the others the medical historian may represent a vaguely disquieting inhabitant of Academe, who is paid for the pleasurable task of browsing in books no one else has the time to read. To the librarian in particular he may be a nuisance whose physical presence is sometimes all too apparent, and who seems to regard the Interlibrary Loan Service as a device created primarily or exclusively for his convenience. Furthermore, he is often a bit of a nag, constantly suggesting expenditures, fully capable of obliterating the total library budget, toward the purchase of rare books which, judged within the totality of the university framework, promise to enjoy equally rare use.

Perhaps the only catholic appraisal of medical historians is that they scarcely justify the sentiment of Francis Bacon that "Histories make men wise." Yet, as an historian, I obviously intend to indicate the felicitous aspects of the various real and potential interrelationships of medical history within the world of scholarship and elsewhere. No Bellerophon threatens the existence of the Chimaera that is medical history; it is here to stay, and I deem its chimaeric nature as one of its greatest assets. A truly interdisciplinary form of scholarship, possessing a variegation which generates diverse interfaces both within and without the university, biomedical history bears a significant relation to many different groups. It is particularly significant to university, biomedical and hospital libraries, and it is of potential utility in the education of librarians. Recognizing clearly that Bacon was perhaps overly sanguine in deriving of wisdom from the reading of histories, I, as a biomedical historian, will attempt to indicate the relevance of medical history and its manifold interrelationships to the general purposes of this conference.

#### Medical History, Medical Schools and Medical Libraries

There has always been some interest in the history of medicine in American medical schools. Admittedly, there has never been any danger that the history of medicine would usurp massive blocks of curriculum time, and it waxed and waned within the medical school environment; the subject has, however, persisted in some medical schools in one form or another, at one time or another. Today the history of medicine is universally recognized as a scholarly field capable of contributing to the educational purposes of the medical schools. Departments of medical history exist in a number of

institutions, and in most other schools there is some kind of program in the history of medicine. In the past the history of medicine was often tolerated as a harmless fillip providing a soupçon of Kultur calculated to mitigate the trade-school atmosphere of medical training and to represent a tangible genuflection in the direction of humanism in medical education. It would be misleading to imply that this attitude does not continue to exist, and it would be equally misleading to allow the inference that the "History is bunk" school of thought has somehow disappeared from the medical schools. Nevertheless, events of the past several years indicate that many medical schools are inclining toward the view that medical history has a definite role in American medical education. There is an increasing awareness of the value accruing to exposure of the medical student to the historical relationships between medicine and society and the social, economic philosophic, and religious forces that have operated to shape the medical profession. To many medical educators the history of medicine appears to offer a means whereby the budding physician can acquire some insight into the position of medicine in the continuous flow of human ideas and events, and it is hoped that this insight will help him to understand and contribute to the future interactions of medicine and society. Much is being asked of medicine, as well as the other health professions, in contemporary America, and it is provoking a rather severe self-appraisal and re-evaluation of the degree of correspondence between existing medical training and the practice of medicine as envisaged several decades hence. Curriculum change runs rampant in American medical schools. The nascent, or, perhaps more accurately, nascent, appreciation of biomedical history reflects in part actual or projected adjustments of medical curricula and purpose to contemporary currents of American social thought. This heightened awareness of medical history reflects also the increased recognition afforded its utility in broadening the cultural horizons of the medical students, who are generally restricted to a relatively pure diet of scientific pabulum as premedical students and exist in medical school on an unleavened diet of medical science and art. These, among other factors, account for a new emphasis upon biomedical history in American medical schools, and this emphasis is likely to increase during the foreseeable future. This means, then, that those medical schools which have been indifferent to or minimally committed to the support of the history of medicine may in the future develop definite programs in medical history and facilitate exposure of the medical student body to its content. This will be a most significant development in the history of American medical education, and it will not be without effect upon medical libraries and those who staff them.

The most immediate and obvious impact of the growth of programs in the history of medicine and its allied sciences upon medical libraries will be upon acquisition policies and programs. A teaching program in biomedical history necessitates an historical collection adjunctive to formal instruction. Good reference material should be abundant, and a teaching program requires, above all, a large and well-rounded group of histories, biographies, journals, bibliographies and catalogues. The collection should also include translations of the classics of biology and medicine and, to a more limited extent, the physical sciences. The inauguration or augmentation of programs in medical history obviously places new demands upon the funds, staff, and space of the medical libraries. It is essentially a problem of acquisitions, the simple accumulation of enough material to contribute toward the general purposes of the teaching of medical history. This is a problem familiar to every librarian and need not be laboured. It is, however, worth



re-emphasizing the importance of an historical collection in any medical school attempting to sustain a sound effort in medical history.

In addition to its teaching function, the medical history department or group discharges a role in scholarship. Again the mint green head of acquisitions peers out from amid the budget accounts. Whether or not one agrees with Henry James that "the historian, essentially, wants more documents than he can really use," it is true that the growth of scholarship in medical history will require the collection of much additional material by the medical libraries. A teaching program can subsist, if necessary, on relatively small, but balanced, collections, but it is impossible to collect too much original material of all varieties to satisfy a vigorous research program in medical history. Fortunately, the currently booming reprint publishing does not make this collecting quite the hit-and-miss proposition or financial venture it could be, although present prices obscure somewhat the economic advantages of reprints.

The growth of historical teaching and research will affect more than acquisition programs in medical libraries. The utilization of the library's resources as an integral part of the teaching program in medical history will pose new challenges to the medical librarians. The student may reveal more enthusiasm than sophistication when he declines a proffered volume of Littré's *Oeuvres d'Hippocrate*, insisting that the librarian fetch instead an original Hippocratic treatise, but who is to deny his enthusiasm? The student-as-nuisance factor is patently destined to increase to a high titre concomitant with increased interest in medical history and growth of an historical collection. The medical librarian should therefore stand prepared to cope, and to cope with tolerance. It should be noted that the medical student is not the only student qua student likely to invade the historical collection of the medical library and to generate new demands upon the staff. Undergraduates often take courses in medical history when they are available to them; graduate students, in fields ranging from anthropology to zoology, are enrolling in courses in bio-medical history in increasing numbers; and graduate and postdoctoral fellows in existing departments of medical history rely heavily upon the total resources of the library. Each species of student uses the medical library in different ways for different purposes, but, to a man, they use the library. Consequently, the anticipated augmented role of the medical library as an adjunct to the teaching of medical history at all levels augurs demands upon the library and its staff far in excess of tolerant coping. There emerges from this forecast, which is, let it be noted, a prophecy substantiated by experience in some medical schools, an increased need for librarians who are familiar with the subject matter of medical history and its literature. The librarian with little more than mild exposure to the subject can be of great assistance to an active teaching program in medical history. Students, whether undergraduate, professional, or graduate, are seldom burdened with surplus time, and they are not always possessed of bibliographic savoir-faire; the librarian who can direct them to appropriate sources or provide them with a small, but critical, bibliographic tip enhances immeasurably the total effectiveness of the medical library and the goals of the medical history program.

The rather obvious points made in the preceding discussion emphasize growth: growth of biomedical history as an academic discipline; growth of historical collections in

associated medical libraries, and at least a need for growth of the number of librarians who are familiar with the content and literature of the discipline. There is something vaguely satisfying about growth, particularly to Americans, and I suspect that most of us cherish a primordial belief that growth is Good. And yet, growth usually poses formidable challenges and creates new problems or exacerbates existing ones. Certain problems of growth deserve comment in the context of this presentation. It should be recognized that, regardless of the degree of interest in medical history in an institution or its student body, there is certain to be some, perhaps considerable, resistance to acquisition of an extensive historical collection, presumably at the expense of the more avant-garde literature. Medical history has long been, and will probably continue to be, regarded by many as a form of academic luxury. I concur with Voltaire's sentiment that "luxury has been railed at for two thousand years, in verse and in prose, and it has always been loved," but it will require more than the self-indulgent love of which Voltaire speaks to effect the most successful and mutually satisfying relation between the medical library and a program in the history of the medical sciences. Even with the available reprints, a solid historical collection will require expenditure of considerable funds; and this expenditure will require defense against objections to accumulation of library items that are dated, and therefore luxurious or prestigious, in contradistinction to the modern and therefore useful. The responsibility devolves upon the library systems to include in their budgets rather substantial funds for acquisitions in the broad area that can be called the history of biology and medicine. In many places this will almost certainly have to be accomplished in the face of pressures for diversion of these funds in other more "practical" directions. The librarian, acquainted with the field and the manifold purposes and values of medical history should better be able to persist in his purpose with equanimity and to defend his purpose with telling effect.

#### Medical History, the Medical Community and Medical Libraries

In an address to the Association of Medical Librarians in 1902 William Osler said, "We desire to foster among our members and in the profession at large a proper love of books. For its own sake, and for the sake of what it brings, medical bibliography is worthy of a closer study than it has received heretofore." Perhaps more than anyone else, Osler, aided and abetted by his colleague at Johns Hopkins, William Welch, contributed to the creation of a kind of American physician characterized by definite bibliophilic proclivities. There is a great and manifest difference between the bibliophile and the historian, we all agree; but bibliophilism frequently leads directly to an active interest in history, and thus a traditional avocation of the American physician is the study of the history of medicine. The bibliophile-amateur medical historian populates all sections of the North American continent, but in those places where an active program in medical history exists, he is encouraged in his efforts and tends to pursue his avocation with greater intensity and, often, with greater attention to the precepts and tools of historical scholarship. Under these circumstances the bibliophile physician makes greater use of the historical collection of the medical library, and medical history thus provides a bridge linking one segment of the practicing medical community with the medical library and, hence, the medical school.

Librarians may anticipate increased utilization of their historical collections as medical history grows in stature in the medical schools and as more physicians graduate from schools with some formal exposure to the subject. The physician should not be discouraged in his efforts to pursue his interests in a more scholarly way, and the medical librarian and medical historian together should occupy an intermediary position in the medical community - medical school axis. I need not dwell upon the Town-Gown phenomenon; everyone is aware that the rapport between the medical schools and the medical community often leaves much to be desired. It is worthy of note, however, because the medical library, through the medium of medical history, can serve as an area of contact which can contribute toward the enhancement of good Town-Gown relations. This is a rather vague thing, to be sure, but a knowledgeable librarian assisting the practicing physician in the accouchement of an historical brain-child can do nothing but create a favorable impression of the medical library and the medical school. And again, some knowledge of the field and its literature can be an immense advantage to the librarian.

There is another facet to the relationships between medical history, the medical library, and the practicing physician. Often the latter tends to collect medical lore, books and documents relating to the medical history of the region in which he practices, and he may have potential value to the librarian in defining and acquiring useful materials for the library's historical collection. The spirit of mutual assistance engendered by the relationship of the amateur physician historian and the library should not be overlooked as a definite by-product of medical history.

#### Medical History and Hospital Libraries

The American public is quite aware of the medical profession in these, our times. Perhaps as never before matters of health care are discussed among the lay population, and, I believe, the public knows more about the profession than at any time past. Perhaps because it is such a part of their lives most people seem interested in medical history; I find, for example, that college students majoring in areas totally unrelated to medicine, such as English, Art, and Far Eastern Studies, display an amazing avidity for the subject. The long residence of Intern X on the best-seller list may indicate this general phenomenon, although it could well be a morbid curiosity attendant upon the initial revelation of the fallibility of physicians. Under any circumstances medical history is of interest to individuals who are neither physicians nor historians; and since much of the agony that attends the continuing social revolution in the United States and the evolution of various schemes for health care derives from the failure of communication between medical and lay communities, medical history may provide a good communications device contributing to better mutual understanding. The inclusion of books of historical import within hospital libraries can hardly be justified on the basis of an intuitive belief that they will underlie a cleaner, neater social revolution. But I can justify that recommendation on the basis of the fact that almost everyone seems to enjoy reading medical biographies, popular accounts of epidemics, cures, and medical discoveries. The fact that there might emerge some better relation between the medical profession and the public at a time when the best relations are desirable may be viewed as a



possible fringe-benefit. As the various medical centers and health complexes develop during the next few decades they are certain to require libraries for the lay reader; I would like to see some selected works on medical history residing on their shelves.

### Medical History, the Medical Library and Medical Library Education

Medical history and the medical library exist in a mutually supportive state. The latter, as the logical repository for the teaching and research resources, is obviously vital to any meaningful effort in medical history. The library is presented, not only with augmented responsibilities by an ambitious, thriving program in medical history, but also some very definite opportunities. Each faculty member within a medical history department or group provides the medical librarian with additional assistance in building the historical collection. By capitalizing upon the expertise of these faculty members, the librarian can add to his holdings wisely. The existence of medical history programs assures use of the historical collection. The larger the medical history department or group, its teaching program, and its research effort, the more extensive will be utilization of the historical collection. Since I persist in the belief that most librarians prefer to see their books used, it should be a somewhat rewarding experience for them to observe the musty old books removed from a state of museum-like petrification and once again enjoying a functional existence. Common utilization of the historical works should present an incentive both to further development of the historical collection and an easier justification for the acquisitions. Furthermore, an ongoing program in the history of medicine tends to attract donations of materials of historical nature to the library, and growth of medical history in the medical school environment may well contribute toward improvement of the historical collections in medical libraries.

A variety of interdisciplinary research is quite likely to result from the growth of medical history as an independent academic discipline. The historian and the librarian together can serve to link various biological and medical specialists cooperating in pursuit of a modern research goal. Communication between specialists is not always easily accomplished, and insight into their common purpose is often attainable in historical context. The modern investigator still reacts unfavorably to the advice that his results were first reported in the mid-nineteenth century, but there is a generally favorable attitude toward the values of biomedical history in terms of gaining perspective and occasional insights. This attitude is likely to be maintained, and the medical historian and librarian may enter, in this supplemental role, into the stream of modern biomedical research through history. If nothing else, this development may enable the librarian to become acquainted with those faculty members who make a personal appearance in the library only to register a complaint.

In the preceding pages an attempt has been made to indicate the future need for medical librarians with some exposure to the content and literature of biomedical history. It was John Ruskin who divided books into two classes, "the books of the hour and the books of all time." One distinct advantage possessed by the librarian trained with some exposure to the history of biology and medicine may be a more incisive evaluation of the books "of all time," as opposed to those "of the hour." Publishers are not loath to



capitalize upon the contemporary rapid rate of advance in the biomedical sciences; the ability to select from the flood of publications those books worthy of more than the notice of the hour may be useful indeed. Medical history as an academic discipline seems destined to grow in the same way the history of science has grown since World War II. The librarian familiar with the subject will be better equipped to deal with and assist students, faculty, and practicing physicians. For these reasons an introductory course in the history of biology and medicine seems desirable for students aiming at careers in medical librarianship if not for all phases of librarianship. The student entering into medical librarianship, if interested, may profit from advanced or graduate courses in medical history. Independent research perhaps with bibliographic orientation, would be desirable when such opportunities exist; there are few better ways to learn the sources, needs, problems, and charms of medical history. The presence of historical collections and medical historians permits special projects for potential medical librarians. Much can be learned by organizing an historical display in its entirety, and performed under the aegis of a medical history program in conjunction with the medical library, such an activity offers a rewarding intellectual and professional experience.

The extent to which a library school can incorporate instruction in biomedical history into its curriculum will necessarily vary according to local conditions. Much is to be gained, however, by considering various ways in which it can and should contribute toward education of the medical librarian. It may be, as Henry Adams suggested, that "The study of history is useful to the historian by teaching him his ignorance of women." I am uncertain that one needs to study history to attain to this Truth, although I concede its utilities in this regard. I hope, however, that this presentation has clarified other uses of the history of medicine and its allied sciences. Among other uses, it offers a new dimension in the training of librarians, and it can have an impact upon library curricula both in terms of meeting new demands and in the general education of the medical librarian. Medical libraries and schools of librarianship should seize upon the opportunities offered by the likely growth of programs in medical history in medical schools and universities. This growth will create problems, to be sure, but the advantages are far more noteworthy. I must agree with La Rochefoucauld's statement that "history never embraces more than a small part of reality," and conclude further that medical history embraces an even smaller part of reality. Nonetheless the challenges presented in meeting the needs to embrace that small part of reality are impressive and will require the combined efforts of the medical historian and the medical librarian. A recognition of this fact in the education of both historians and librarians may enhance the necessary combined efforts during the years to come.

**MEDICAL HISTORY, LIBRARIES AND CURRICULA**  
by Dr. Charles W. Bodemer

**Points from the Group Discussion**

---

1. A general survey course in the history of medicine at the upper division level contains material that is applicable to all of the basic sciences, and many of the paramedical fields.
2. Students should share an intellectual exchange from differing viewpoints. In upper division or graduate courses, there is a great deal of interplay between individuals--they discover how the other person thinks. The sooner people who are destined for later contact with one another come to appreciate the variations in attitudes that distinguish the physician from the basic scientist, the historian, the librarian, etc., the better it is for their future relationships.
3. Attention should be given to the history of medical communication as it differs from the social history of medicine. Medical communications deals with man's attempts to provide the next generation with both the facts he has uncovered and the relationships he thinks he discerns between the facts. Is it realistic to include this in general course content of the library school or should it be reserved for the health sciences librarian? Should the history of medical communication be taught as a separate course or should it be incorporated into all courses?
4. Preservation of, and access to, oral history should be considered a responsibility of the health sciences library.
5. What is the health science librarian's role as an archivist, as a collector of local history? Should archival management be a part of the curriculum?
6. Is library specialization to be determined by field of knowledge or by the audience served? Or by a combination of both?
7. We must think in terms of the person who is using information and resources. This necessitates planning for the cooperation of all types of libraries to meet the users' informational needs rather than fragmenting libraries by type.
8. Library schools, using existing research on user populations, should also continue research in the areas of library specialization and cooperation.

FOURTH SESSION

LEVELS OF PREPARATION REQUIRED FOR MEDICAL LIBRARIANSHIP

By

David A. Kronick  
Librarian, Medical Library  
The University of Texas Medical School at  
San Antonio

In the broadest terms suggested by the title assigned to me, my job is to write the job specifications for all the positions which are required to man the various stations of the biomedical communications and information network, both as it exists today and as it may evolve in the future. Alan Rees' job of telling us how to educate people for these positions would then be greatly simplified, because all he would have to concern himself with would be the content and the methodologies of the training required to meet these specifications. I hope I won't disappoint you too much when I say I am not totally prepared to deliver this to you as a completed package. Lack of diligence on my part is not the entire reason for this failure. There is, first of all, a lack of necessary data as to the requirements of the system upon which such specifications could be constructed, not that this is always a deterrent. Secondly, there is no general agreement about what tasks, responsibilities and functions to subsume under the general rubric of medical librarianship.

The subject assigned to me in this respect has both too great and too little a specificity. We can remedy the excess of specificity by saying where the term "medical" is used also read "health science," "health professions," or "health related," and where the term "librarianship" is used read also "information specialist" and, if it is not already an archaic term, "documentalist." When reference is made to levels of training, on the other hand, I am not sure whether we should confine ourselves primarily to formal education, such as the programs under discussion here at the School of Librarianship of the University of Washington, or to the full range of training required to staff all position levels. And again, if we are to concern ourselves with formal training, shall we concern ourselves with the totality of formal training which goes into producing a medical librarian, or only that part which is library or health science library related. Almost everyone thinks he has a fairly good concept of what a library is, but once we introduce the term "information services" into the conversation, we are not quite sure what we are talking about. Shall we include abstracting and indexing, editorial and other publication services, and even teaching, film and television production, or as in the Auerbach study, drafting, printing, manual writing and even "spare parts provisioning" or whatever its equivalent function may be in the health field?<sup>1</sup>

In addition to these ambiguities, we lack, in general, much precise data not only on the kind and quality of performances we require from the biomedical information services, but also when, where and how they should be carried out. With very few notable exceptions like Vern Pings, very few people have made an effort to describe and measure the tasks and functions performed in the medical library. This has not, of course, deterred people from making pronouncements on the subject. Many of you will remember exercises like this in the past dealing with the "qualifications for medical librarianship." I remember one such exercise many years ago which started out with the usual minimal requirements such as a graduate degree in one of the sciences basic to medicine, proficiency in two or three foreign languages, and a nodding acquaintance with several others. What alerted me to the fact that like God we sometimes try to create our descendants in our own image, is that this particular design for a medical librarian emphasized an ability to transliterate from the Russian. This is a skill which



almost anyone can acquire in ten minutes -- and forget in five. I concluded, therefore, that this particular librarian did not number flute-playing among her accomplishments, or she might have included this also as one of the requirements.

Despite our lack of data, however, it is imperative for us to try to answer questions like: what are the qualifications of a medical librarian? What kinds of skills and training will be required to staff the developing programs for making the full impact of our newly won knowledge felt upon the provision of optimum health care? The issue here, as our recent library literature has abundantly recognized, is primarily one of manpower. If we can specify what our manpower requirements are and what they are going to be in the future, then we will have been of real value to our hosts, because then they will be able to set about with an easy mind to train people for the real world of the present and the future. Without the manpower, no matter how resourceful and imaginative the programs we develop for providing medical information networks and services, they will avail us nothing if we don't have enough people to staff them.

If we are able to define precisely what the issues and requirements are in (A) manpower, they will have their inevitable corollaries on the side of (B) education and training:

- A. What are the specific tasks that people have to perform in providing biomedical information services?
- B. What education and training will best prepare them to perform these tasks?
  
- A. How many people will be required to perform each of these specific tasks?
- B. How many people should we be recruiting and training?
  
- A. In what kind of institutional settings will these tasks be performed?
- B. What kind of information and skills should these students acquire?
  
- A. What kind of people in terms of background, ability, and other personal attributes will we require?
- B. What kind of people should we try to attract and recruit?

I do not mean to imply that we must have definitive answers to these questions before we can begin to design effective teaching programs. We have been doing so empirically and on the basis of intuitive judgements for a long time. But I do think we will be able to design programs which are more responsive to our real needs when we begin to acquire some of this information. Educational systems are frequently in a kind of double jeopardy of finding themselves in the position of teaching the substance of past practices to a group of practitioners who will be spending the largest part of their professional life practising under future conditions.

These issues are, of course, not unique to medical librarianship. Being a part of a very new medical school, I have been privileged to sit in on discussions of the

problems of designing a curriculum. These problems are essentially not very much different than ours; how to train competent practitioners who will be able to carry out their social functions in an evolving social and scientific setting. They start out as we have by trying to determine first what kind of a product they want at the end of their educational efforts. If they were to determine, for instance, that their primary obligation is to train practitioners who will stay in the community in which they have been trained, then the curriculum will take one shape. If they feel that they have a primary responsibility to train people for academic or research medicine, then this too will be reflected in the curriculum. There seems to be general agreement on two points, that they do not want to do unto others as was done unto them, and that there is a core of information and skills which should be in the possession of every qualified practitioner. Medical faculties are very sensitive to the fact that when they have put their imprimatur upon a new physician, they have made an implied promise to society about his capabilities.

In the same way we must begin by asking ourselves what do we wish the graduates of our programs to be able to do. We will need to be able to define more clearly the natures and the needs of our various clienteles before we can determine how best to meet them. What are the information needs of the general practitioner, the investigator? Are his needs for broadly selected literature citations, or critically evaluated information? In what kind of settings do these needs occur? What is the significance of response time in various situations? We can get some of these answers by careful analytical studies. Another method of achieving a similar result would be to actually look at what practitioners in the health related information services are doing, and to try to determine how effectively they are meeting the demands made upon them. We need studies of the type that produced "An Analytical Study of North Carolina General Practice, 1953-1954."<sup>2</sup>

This study was, in a sense, an evaluation of the results and the quality of medical education, in that to a certain degree the level on which the practitioners were performing could be considered a direct reflection of their education. In fairness to the educators we must admit that there were undoubtedly other factors involved which might have been just as important, or even more important, and which were of a social and economic rather than an educational nature. However, this was one method of identifying some of the deficiencies which may exist in practice, and which education could participate in alleviating either through changes in the basic medical curriculum, or through continuing or other education. The study also performed another important function. It helped to assess the work load which the practitioner meets in his daily practice, the kind of problems he is called upon most frequently to solve, and, therefore, those areas in which he needs his greatest competence. The emphasis of the study was not merely upon the quantitative aspects of the practice, but on the quality of the medical care that was being supplied. There was one significant fact revealed by the study which I don't think that any of you will find particularly surprising. It indicated that a close relationship existed between a high level of performance in medical school and a high level of practice, that is, that those who tended to be better students academically, also tended to be better practitioners. In fact, if I could write a prescription for

upgrading training for medical librarianship in a single sentence, I would simply say, "Recruit good students."

I have thus far been flirting, not very successfully, with the problem of identifying some of the special skills that are required to staff the medical library network, and by implication the preparation that might be required to achieve these skills. I have not paid much attention to another word in the title, "levels." I could reason that in the first place if we succeed in identifying the skills and the training required for them, then we will have more or less automatically identified the levels of preparation required. One of the problems, and it is frequently at the core of the discussion of professionalism and nonprofessionalism in librarianship, is that in analyzing performance, attention is sometimes focused on the act itself rather than upon the judgment which informs it. It is almost as if we were to say that to be a good surgeon you need primarily to be able to wield a scalpel. Whereas, the important thing sometimes is, to change the metaphor, not to be able to play Chopin's Minute Waltz in sixty seconds, but to play it so that it has meaning. This is what we imply when we say that in professional education it is more important to teach attitudes than to teach skills. It is frequently just as important to know for what purpose one is providing information as to be able to supply it efficiently and quickly. Philosophy without technique is sterile, but technique without philosophy is shallow and unresponsive to real needs. This issue is also at the center of the argument that librarianship lacks "content" or a "philosophy"<sup>3</sup> and therefore is not really a profession or even worse, because it sounds somewhat disreputable, a "quasi-profession." I think we must confirm our professionalism because it implies a real career commitment, and a real dedication to service. In establishing classification levels for positions, emphasis is just as frequently placed on the degree of independent judgement exercised and on degree of responsibility displayed as it is on the content and special skills.<sup>4</sup> The question the educators have to answer is what are some of the factors and training which contribute toward the ability to exercise responsible judgement. Not all of it, I am sure, will be training in management skills and in systems analysis; some of it will have to be based on the theoretical, historical and "philosophical" bases of the functions performed.

Designations of levels are applied not only to levels of responsibility, but can also be applied to levels of training, although they do not necessarily need to be related. Faced with the acute manpower shortages in medical librarianship, as well as in general librarianship, many have advocated the development of library technician training programs, and almost as many have risen up in arms against them. The advocates argue that a large part of the work done in libraries does not require graduate or even collegiate training.<sup>5</sup> I am one of those who is not convinced that we should divert much of our energies toward providing formal training for technicians to perform routine and elementary jobs, at least not as specialized medical library technicians. In the first place it does not seem fair to ask people to make career commitments of this kind, particularly in smaller communities where employment opportunities might not always be available. In the second place all the indications show that in the information services it is more highly qualified people that we desperately need, rather than more lowly qualified. I am in sympathy also with those critics who say that this kind of



program would tend to dilute and lower levels of services rather than to raise them.

Any service organization is most vulnerable at those points in which service is supplied. Another way to phrase this would be to say that Macy's (and to be utterly impartial I suppose I should also add Gimbel's) is at the mercy of its lowliest clerk in establishing and keeping its reputation for service. One of the problems is that decisions and judgements are sometimes made by people who lack the necessary training or experience to make competent judgements or decisions. It has been reported to me, although I have not had it confirmed, that Tom Fleming has a standing rule in his library that staff assistants may say "yes" when they can definitely answer a request in the affirmative, but must refer all "no" answers to other more highly trained or experienced members of his staff. I learned recently that there is a practice which bears a striking resemblance to this practice in military medicine and civilian defense. The term applied to it is "triage" and it embodies a concept that is of the highest significance not only in medical care in general as well as the management of mass casualties, but also in the management of medical libraries, libraries in general and indeed any kind of a service organization. "Triage" is, of course, the French word for sorting and in military medicine it refers to the sorting of casualties in the field, classifying them for further treatment, treating those which can be treated there, taking care of the most urgent emergencies, and sending the others back to other hospitals in the rear echelons.

I have not been able to explore this most interesting and fruitful concept in depth. Herbert Fockler has given me some interesting leads I hope to be able to follow, particularly in relation to a community health program in which everyone in the community including or especially the local bartender is involved. One of the problems, of course, may be that the bartender may not only be willing to refer the mental health problem to the proper facilities, but that he may also be willing to undertake the therapy himself. One way, therefore, we can use less highly trained practitioners, or conversely make maximum use of our more highly trained and qualified ones, would be to build more "triage" into our systems, both within the individual service units and among groups of such units.

In order to write the job descriptions and specifications for all the different kinds of personnel we will need to staff the medical library information services, we will need to know not only the kinds of jobs we need to train people for, and the levels of training required, but also what numbers of people we will require in each position and each level. In the medical library field I know only of one report which has attempted this<sup>6</sup> but not with any degree of specificity that would help greatly in designing educational programs. A study by the Departmental Task Force on Social Work Education and Manpower of the Department of Health, Education and Welfare<sup>7</sup> probably comes closest to parallel the kind of survey we need as medical librarians, although it too does not provide the kind of detail upon which educational planning can be built. The following statement from the introduction by the Task Force Chairman could be repeated almost verbatim by substituting the words "medical library" for "social work": "...the number of qualified social work personnel in the United States is so low in comparison with demand as to impair the continuation of vital social services and to hamper the effective



implementation of any new program authorized in the past several years by the Congress."<sup>8</sup> The survey explores the distribution, geographically and by activity and training, of the current social work force, attempts to project future requirements and the means available and needed to meet them. There is a paucity of such data about the manpower requirements of the medical library field. The situation with regard to public and academic librarianship is a little better, primarily because projections can be made on the basis of standards set up by the American Library Association, which states, for instance, that academic institutions should have three librarians for each 600 full time student equivalents (a standard which does not help us very much). The resulting estimates, e.g. that there is a manpower gap of 8500 professional librarians in academic and public libraries<sup>9</sup> are based on current and replacement needs rather than projected requirements. They do not take into consideration expansion through growth of activity or change of function.

There are a number of other interesting facts about manpower requirements that are relevant here. First, it takes large increments in training capacity to significantly alter the total supply of personnel in any particular field.<sup>10</sup> Thus, since the working life of professionals is between thirty and forty years, a change of one per cent in manpower requirements may mean an increase of thirty to forty per cent in annual output.<sup>11</sup> Another fact is that the increased demand for trained personnel has the paradoxical quality sometimes of reducing the supply, since a larger proportion of them are needed to staff the educational system. I am sure most of you are aware of this phenomenon recently in the field of library education, where we have witnessed the exodus of several outstanding librarians from management positions to new library schools. The report of the Commission on Heart, Cancer and Stroke indicates that of the 6300 medical libraries of record, only 3000 are staffed by medical librarians. This does not provide us with any measure of the deficit among libraries which have substandard staffs either qualitatively or quantitatively, or any indication of what our deficits will be in the future.

I have indicated that I don't believe we have enough data at this time to write the specifications for the kind of medical library training we need to staff either current or future needs. We don't know with any degree of certainty what people are doing, how well they are doing it, and of most importance, what needs to be done. This need not and will not deter us, of course, from developing medical library training programs as indeed it has not deterred several of us from doing in the past. I think we all recognized that we had to resign ourselves to some drastic compromises in terms of the amounts of time allotted to us, in terms of our options in setting our own prerequisites, and in terms of the best allocation of the available time. Each of us, I imagine, designed our course content on our own experience, although frequently with the help and consultation of our colleagues who had taught the course before us. If we had a philosophy about the goals and objectives of our course, it had pretty much to be tailored to the limits of time and resources with which we were faced. I realize I am encroaching on Alan Rees' territory in talking about the content of the medical library training program, but it will help to sum up what my judgements were then, empirical as they were, about the preparation required for medical librarianship. The medical librarian is a special librarian in a way similar to which the pediatrician is a special kind of a physician.

Perhaps a better comparison in view of Richard Orr's suggestion that what we are doing is to help metabolize information, would be the gastroenterologist. What is special about the medical librarian is the special clientele and a special body of literature. It is the medical librarian's function to mediate between this special clientele and this special literature. The techniques of mediation, of course, involve the full spectrum of library techniques, or economy as our ancestors used to call it, covering all the aspects of acquisition, storage and retrieval of information, in a manner which most accurately and effectively reflects the current state of the art in these technologies.

In a sense we have set ourselves the same kind of goals in medical information and library services that the regional medical programs have set themselves in health care - the delivery of the optimum level of medical care which is consistent with the present state of the art. I think we could echo their conclusions that a gap does exist, how wide we do not know, between our practices and the state of the art. We have also put ourselves on record as saying with them that one of our concerns is not only with catching up with the state of the art, but of creating the necessary mechanisms to keep abreast of it. The health care professions have a long lead on us in determining what their requirements are, even though in the regional planning programs they are still busily gathering this kind of data. We will not be able to implement our goal of delivering the optimum level of information and library services that is consistent with the state of the art, or indeed of determining what preparation is necessary for medical librarianship, until we set about systematically to gather the necessary data ourselves.

## REFERENCES

- <sup>1</sup>A Study of Manpower Requirements for Technical Information Support Personnel. (CFSTI-AD 607-893) (Washington, D. C.: Auerbach Corporation, January 10, 1964.
- <sup>2</sup>O. L. Peterson et. al., "An Analytical Study of North Carolina General Practice, 1953-1954," Journal of Medical Education, XXXI (December, 1956), 12 pt. 2.
- <sup>3</sup>Philip H. Ennis, "Seven Questions about the Profession of Librarianship," Library Quarterly, XXXI (October, 1961), 299.
- <sup>4</sup>Marjorie M. Tompkins, "Classification Evaluation of Professional Librarian Positions in the University of Michigan Library," College and Research Libraries, XXVII (May, 1966), 175.
- <sup>5</sup>"Library Education and the Talent Shortage," Library Journal, XCI (April 1, 1966), 1761.
- <sup>6</sup>Saul Herner et. al., A Recommended Design for the United States Medical Library and Information System. Volume 1, System Design, Implementation, and Costs. (CFSTI, PB 172-923) (Washington, D. C.: July 1966).
- <sup>7</sup>U. S. Health, Education and Welfare Department. Departmental Task Force on Social Work, Education and Manpower. Closing the Gap in Social Work Manpower. (Washington, D. C. : 1966).
- <sup>8</sup>Ibid.
- <sup>9</sup>Sarah R. Reed, "Library Manpower Realism, Relevancy and Requirements," Journal of Education for Librarianship, VII (Summer, 1966), 43.
- <sup>10</sup>Richard A. Lester, Manpower Planning in a Free Society (Princeton, N. J. : Princeton University Press, 1966), p. 9.
- <sup>11</sup>Gottfried Zombach, "Manpower Forecasting and Educational Policy," Sociology of Education, XXXVIII (Fall, 1965), 347.

## LEVELS OF PREPARATION FOR MEDICAL LIBRARIANSHIP

by Dr. David A. Kronick

### Points from the Group Discussion

---

1. What is the relationship of health sciences librarianship to the general field of information science? Programs of education in this field have clear relevance to library needs and requirements, but how closely do they interrelate?
2. There are few studies of the various levels of preparation for health science library personnel. What can be done about the shortage of middle management personnel?
3. What are the professional goals and standards of health sciences librarianship? There is a need to design educational programs concurrent with the determination of goals and standards.
4. Education for librarianship should be evaluated in terms of the end product--service. Will an educational program designed with the user as the ultimate criterion necessarily resemble the current profession-oriented program?
5. How can additions be made to an already full library education curriculum? Could sufficient time for the teaching of principles be found if the teaching of methodology were diminished? If students are grounded in theory will they be able to apply this theory to specific situations? Is there some better way in which theory and methodology can be combined in graduate instruction for the health sciences librarian?
6. When a profession demonstrates that its services are essential to a community, it becomes a necessity.
7. Service is provided at different levels. These levels should be identified and described. It may be that our best prepared personnel belong in the hospital where the most direct contact with the information consumer takes place.
8. An analysis of the health sciences environment must be made to determine kinds of clientele, their tasks and their levels of demand. This requires job analysis and systems analysis which will provide a basis for the determination of what the job is, who should do the job, and what should not, as well as what should, be done. Existing analyses, generated by individual libraries, are useful but emphasis in the future must be on the entire system of health science libraries.



FIFTH SESSION

CURRICULUM CONTENT FOR EDUCATION IN MEDICAL LIBRARIANSHIP AT SEVERAL LEVELS

By

Alan M. Rees  
Director and Associate Professor  
Training Program in Medical Librarianship  
Western Reserve University  
Cleveland, Ohio

The purpose of this paper\* is to review existing educational programs in medical librarianship and to evaluate the curricula in relation to present and projected manpower requirements. Prime emphasis will be placed upon the definition and elucidation of medical librarianship as a specialization in library practice. Levels of educational preparation will be discussed within this context. Four main areas will be explored:

I. Specialization in Librarianship

II. Medical Librarianship as a Specialty

III. Present Educational Programs in Medical Librarianship

IV. Proposed Design of a Specialized Educational Program in Medical Librarianship

I. Specialization in Librarianship

Two salesmen in a hotel room one afternoon were arguing with increasing vehemence about the growing specialization in industry. They cited more and more extreme illustrations of the trend until the first suddenly exclaimed, "I'll bet you \$10 the National Biscuit Company has a Vice-President in Charge of Fig Newtons." The second answered in shocked disbelief, "You're crazy. I'll take that bet. No company would go that far. We'll put in a long-distance call to the National Biscuit Company and ask for the Vice-President in Charge of Fig Newtons."

So they put in the call. It went through quickly. The receptionist at the National Biscuit Company home office answered the phone. The salesman said, "Miss, I want to speak to the Vice-President in Charge of Fig Newtons. Please put him on." Her reply was a staggering one. Across the miles of wire came her sweetly articulated reply, "Which vice-president do you mean--the one in charge of production or the one in charge of sales?"

\* \* \*

The existence of specialization in librarianship is acknowledged but not proven. Each branch of the tree of librarianship appears superficially to be a discrete limb with a

---

\*The assistance of Miss Barbara Denison, Research Assistant and Executive Secretary of the Training Program in Medical Librarianship, School of Library Science, Case Western Reserve University, is gratefully acknowledged. Mr. Walter Walker, a trainee in the Training Program, was helpful in the preparation of the tables.

shape and magnitude of its own. The shibboleth of separateness is supported by countless library practitioners who continue to emphasize differences rather than similarities. Special librarians claim to be "special" by virtue of their concern with special materials, special subject areas, highly defined needs, more intensive information services, non-conventional systems, deeper and more varied subject analysis, peculiar organizational structure, aggressive rather than passive attitudes, etc.<sup>1</sup> Many practitioners zealously treasure the elixir of special librarianship. Likewise, fierce intra-group partisanship exists among law librarians, music librarians, academic librarians, map librarians, newspaper librarians, school librarians, insurance librarians and so on. Educational offerings catering to the individual and peculiar interests of these groups have proliferated. Even religion has infiltrated the educational scene in the guise of special courses in synagogue librarianship and seminary librarianship, with Protestant and even ecumenical librarianship doubtless yet to come. The prevalence of such exotic educational delicacies is occasioned by the strong and persistent feeling that traditional library school programs have failed to provide the educational preparation appropriate to each and every specialty. It has been, and is, assumed that library education can be packaged into small capsules ready for dispensing to persons desirous of pursuing any specialized splinter of library practice.

Such specialization in library practice--whether by type of library, by nature of materials handled, or by function performed--has yet to approximate the degree of specialized practice existing in medicine. Pediatrics, psychiatry, surgery, ophthalmology stand as reasonably discrete areas of practice, fostered by educational institutions, governed by specialty boards, and sanctioned by law. The relationship between medicine and its specialties is well defined and structured. By contrast, library science has not isolated the "core" common to all branches of librarianship, let alone delineating areas of specialization. Consequently, what masquerades as a fully developed specialization is most often a rehash of theory, tools and techniques applicable in all branches of librarianship, perhaps presented within a matrix of specialized terminology. While most library schools have added an increasing number of single courses oriented towards music librarianship, medical librarianship, and other areas, several have refused to permit a fragmentation of the field.\* It is argued here that specialized library education programs can be developed although along lines somewhat different from the technique-and gadget-oriented educational offerings demanded by many library practitioners. It is also argued that medical librarianship is a valid field for specialization. This topic is discussed at length in Section IV below.

---

\*One dean comments in a private communication: "We do not offer specialized courses in medical library literature...nor are there in the curriculum courses dedicated to special types of libraries, since our program is organized to take a conceptual, theoretical, functional rather than how-to-do-it approach, thereby avoiding the repetition of much basic material in a superficial way under type-of-library headings."

## II. Medical Librarianship as a Specialty

Medical librarianship has not been exempted from the sense, often emotional, of special identity. W. J. Bishop,<sup>2</sup> in reviewing the history of the Medical Section of the Library Association, expressed distress at what medical libraries in England, "took to be an attempt on the part of some public libraries to enter into the medical field and to attempt to supply purely professional literature alongside the legitimate and wholly admirable service to hospital patients. There has been a confusion between libraries for patients and technical libraries for medical students and staff. The latter type of library we take regard as our exclusive preserve: the work is one of the most highly specialized departments of librarianship and we would deplore any attempted penetration of public libraries into this field, both from the point of competency and public welfare." Further evidence of difference is cited by Margaret Russell,<sup>3</sup> who writes: "How are medical libraries different from general libraries? In short, the subject matter is different; working with it requires a fair knowledge of a very specialized terminology. Medicine has been and is richer in bibliographic tools than any other field of science.... Moreover, the needs of the people using the library are different --so much of what they require is for today, and delay means frustration."

The theme of specialization was developed in educational programs at an early date. The first course in medical librarianship was given in 1939, and internships were established at Tulane's Rudolph Matas-Orleans Parish Medical Society Library in 1941 and at Vanderbilt in 1944.<sup>4</sup> Two years later the Presidential Address of Mary Louise Marshall to the Medical Library Association emphasized the basic differences between medical and other librarians, calling for specialized training. The present system of MLA accreditation of courses and internships and certification of graduates evolved from discussions and decisions resulting from Miss Marshall's Presidential Address.

By 1957 Thomas Fleming<sup>5</sup> was encouraged enough to write that modifications in library school curricula in general and at Columbia University in particular were both possible and desirable. Flexible arrangements based upon a core curriculum would be made, Fleming predicted, "to permit specialized programs for individuals seeking professional preparation in specific areas. Training for medical librarianship from now on will be planned for a student from the time he enters library school until the conclusion of his course." His conclusion was that "education for medical librarianship is entering into a new phase." It is quite clear that ten years ago Fleming was thinking in terms of a curriculum for medical librarianship, a planned sequence of courses based upon the generalized core curriculum.

Fleming's high hopes for the development of a specialized curriculum for education in medical librarianship have proved to be unfounded. There can be little doubt that the quality of librarians graduated from most library schools has improved since 1957, considering modifications in the core and the penetration of information retrieval, library automation, and information science into the curriculum.<sup>6</sup> Better general librarians are now graduated, but it is doubtful whether Library school graduates are better prepared in 1967 to function as medical librarians than they were in 1957.



### III. Present Educational Programs in Medical Librarianship

Sixteen of the 42 ALA-accredited library schools offer a course, or a sequence of courses, in medical librarianship as part of the M.S. in L.S. degree program (Table 1).

Table 1

Graduate Schools of Library Science  
Engaged in Medical Library Education

	Courses Offered		
	<u>Type I</u>	<u>Type II</u>	<u>Type III</u>
1. Case Western Reserve University	X	X	X
2. Catholic University of America		X	
3. Columbia University	X		X
4. Drexel Institute of Technology	X	X	
5. Emory University	X		
6. University of California at Los Angeles	X	X	
7. University of Chicago*	X		
8. University of Illinois (Chicago Medical Center)		X	
9. University of Maryland**			
10. University of Michigan	X		
11. University of Minnesota***			
12. University of North Carolina	X		
13. University of Oklahoma	X		
14. University of Pittsburgh	X		
15. University of Southern California		X	
16. University of Toronto	X		

\*Two courses listed in University of Chicago Graduate Library School Catalog with no instructors indicated. No information is available as to course structure, content, organization, etc.

\*\*No information available.

\*\*\*No information available.

Seventeen instructors teach a total of 19 courses (Table 2). Examination of the titles and content of these courses reveals the existence of three types: Those designed to provide a general introduction to medical librarianship or Type I courses (Table 3); those devoted primarily to medical bibliography or Type II courses (Table 5); and those developed to provide instruction in depth in specialized aspects of medical librarianship (Appendices 1 and 2). In effect, the last are specialized courses within the

Table 2

Instructors in Medical Librarianship and Course Titles

	ACADEMIC RANK	ADMINISTRATIVE POSITION	COURSE TITLE
Bishop, Dr. Olga B.	Associate Professor, University of Toronto		Medical Literature
Cheshier, Mr. Robert C.	Assistant Professor, Case Western Reserve University	Director, Cleveland Health Sciences Library, Case Western Reserve University	Organization of Medical Practice and Research
Connor, Mr. John M.		Librarian, Los Angeles County Medical Association	Bibliography of Bio-medical and Physical Sciences*
Darling, Miss Louise	Lecturer in Library Science and Medical History, UCLA	Librarian, Biomedical Library Center for Health Sciences, UCLA	Bibliography of Medical and Life Sciences Medical Librarianship*
Ebert, Miss Myrl L.	Associate Professor of Medical Bibliography, University of North Carolina	Librarian, Division of Health Affairs, University of North Carolina	Seminar in Medical Librarianship*
Eddy, Mr. Leonard	Part-time Faculty Member University of Oklahoma	Librarian, Medical Center University of Oklahoma	Medical Librarianship
Ember, Mr. George	Instructor in Library Science Case Western Reserve University	Manager, Research Resources, Center for Documentation and Communication Research, Case Western Reserve University	Medical Subject Analysis and Searching
Fleming, Mr. Thomas P.	Professor of Library Service Columbia University	Head, Medical Sciences Division Columbia University Libraries	Medical Literature and Librarianship*
Fulcher, Mrs. Jane M.	Lecturer, Catholic University of America	Librarian, Washington Hospital Center	Medical Literature and Librarianship*
Kruzas, Mr. Anthony T.	Associate Professor, University of Michigan		Medical and Technical Library Administration
Lentz, Mr. Robert	Instructor, Drexel Institute of Technology	Librarian, The Jefferson Medical College Library	Medical Librarianship Medical Bibliography
Libbey, Miss Miriam H.	Part-time Faculty Member, Emory University	Librarian, A. W. Calhoun Medical Library, Emory University	Medical Librarianship*
Meckel, Miss Clara L.	Associate Professor, University of Illinois--Chicago	Circulation-Reference Librarian University of Illinois Medical Center Library	Medical Literature and Reference Work*
Morris, Dr. Thomas C.	Lecturer in Library Science Case Western Reserve University	Librarian, Allen Memorial Library Case Western Reserve University	Introduction to Medical Librarianship*
Pings, Dr. Vern M.		Librarian, Wayne State University School of Medicine	Medical Bibliography and Medical Library Administration*
Reynolds, Dr. Carroll G.	Part-time Faculty Member University of Pittsburgh	Librarian, Maurice and Laura Falk Library of the Health Professions University of Pittsburgh	Medical Literature and Librarianship*

\*Denotes MLA accredited courses for Grade I certification

Table 3

Type I Courses--Medical Librarianship (General)

<u>GRADUATE LIBRARY SCHOOL</u>	<u>COURSE TITLE</u>	<u>INSTRUCTOR</u>
University of California at Los Angeles	Medical Librarianship (481)	Miss Louise Darling
Case Western Reserve University	Introduction to Medical Librarianship (LS592)	Dr. Thomas C. Morris
University of Chicago	Biomedical Information (353)	Unknown
Columbia University	Medical Literature and Librarianship (K8212x or S8212g)	Mr. Thomas P. Fleming
Drexel Institute of Technology	Medical Librarianship (L564)	Mr. Robert Lentz
Emory University	Medical Librarianship (309)	Miss Miriam H. Libbey
University of Michigan	Medical and Technical Libraries (740)	Mr. Anthony T. Kruzas
	Medical Bibliography and Medical Library Administration (742)	Dr. Vern M. Pings
University of North Carolina	Seminar in Medical Librarianship (348)	Miss Myrl L. Ebert
University of Oklahoma	Medical Librarianship (319)	Mr. Leonard Eddy
University of Pittsburgh	Medical Literature and Librarianship (LS237)	Mr. Carroll C. Reynolds
University of Toronto	Medical Literature (1047x)	Dr. Olga B. Bishop

specialization. This classification, while appearing to be arbitrary, is believed to be sound in view of differences in stated objectives and course content.

(a) Type I Courses--Medical Librarianship (General)

Eleven library schools offer a general introductory-type course to medical librarianship. Six of these courses are accredited by MLA for Grade I certification. A detailed analysis of course descriptions, syllabi, assignments, reading lists, and correspondence with the instructors of these courses reveals that an heroic attempt is made (within the limitations imposed by one semester) to cover all aspects of medical librarianship. One instructor notes: "Approximately twelve weeks of the semester is given to the study of the literature; the remaining weeks are devoted to selection, acquisition routines and problems, cataloging and classification, special collections and management in the medical library field as it differs from other forms of librarianship.... We do an awful lot of skimming as you can plainly see."

The scope of Type I courses is most comprehensive (Table 4), ranging from history of medicine, medical bibliography, reference, periodicals, medical terminology, inter-library loan, acquisition and book selection, drug information, medical library administration, automation, library networks, medical statistics, circulation, cataloging and classification, rare books, the medical community, planning and architecture, indexing and abstracting, to bibliotherapy. Heavy emphasis is placed in five areas: bibliography, reference, acquisitions, administration, cataloging and classification. With a few exceptions, the instructors are practising medical librarians and not full-time library schoolmen. Clearly, their teaching is based upon actual operational experience with a minimum of theory.

The massive nature of the content which must be covered within a very restricted period of time has impelled a number of instructors to divide this subject matter into two courses. Louise Darling at UCLA teaches "Medical Librarianship" (LS481) and "Bibliography of Medical and Life Sciences" (LS218). Likewise, Robert Lentz at Drexel offers "Medical Librarianship" (LS564) and "Medical Bibliography" (LS563). Another instructor comments that he is "exploring the possibility of replacing the existing course [Type I] with two courses, one consisting of medical bibliography and the other consisting of history, terminology, cataloging and classification, administration, the medical community, etc." A reasonably clear differentiation is made, in this manner, by these instructors between general courses and courses in medical bibliography. In other cases, discussed below, the lines of demarcation are not so sharply defined.

(b) Type II Courses--Medical Bibliography

Six courses in medical bibliography (Table 5) are offered currently; four are accredited by MLA for Grade I certification. These courses cover both preclinical and clinical sciences, and most also review the bibliography of auxiliary fields. Other topics discussed include abstracts, indexes and translations; reference work and the compilation of bibliographies; automation; terminology; sources of drug information; cataloging and



Table 4

Content of Type I Courses--Medical Librarianship (General)

TOPICS	INSTRUCTORS										
	Morris	Fleming	Libbey	Lentz	Darling	Pings	Ebert	Eddy	Reynolds	Bishop	Kruzas
Medical History	X							X	X	X	
Medical Bibliography	X	X	X		X	X	X	X	X	X	X
Reference	X	X	X	X	X	X	X	X	X	X	X
Periodicals				X					X	X	
Terminology	X										
Interlibrary loan				X	X	X			X		
Acquisition--book selection	X	X	X	X	X		X	X	X	X	X
Drug information								X			
Medical Library Administration		X		X	X	X	X	X	X	X	
Automation in Medical Libraries	X		X		X	X		X			
Library Networks			X			X					
Medical Statistics								X			
Circulation	X		X	X							
Cataloging, Classification	X	X	X	X	X	X	X	X	X	X	
Rare books					X				X	X	
Structure and Organization of Medical Community	X		X	X		X		X			
Planning and Architecture				X		X					
Indexing-Abstracting			X	X		X					
Bibliotherapy								X			

Table 5

Type II Courses--Medical Bibliography

<u>GRADUATE LIBRARY SCHOOL</u>	<u>COURSE TITLE</u>	<u>INSTRUCTOR</u>
University of California at Los Angeles	Bibliography of Medical and Life Sciences (218)	Miss Louise Darling
Catholic University of America	Medical Literature and Librarianship (728)	Mrs. Jane Fulcher
University of Chicago	Biomedical Bibliography and Reference Service (354)	Unknown
Drexel Institute of Technology	Medical Bibliography (L563)	Mr. Robert Lentz
University of Illinois	Medical Literature and Librarianship (E489)	Miss Clara L. Meckel
University of Southern California	Bibliography and Biomedical and Reference Services (530)	Mr. John Connor

classification; MEDLARS; communications in medicine; medical statistics (Table 6). The areas principally emphasized appear to be: bibliography in most preclinical, clinical and auxiliary fields; abstracts, indexes and translations; reference; and terminology. Although the two instructors offering both Type I and Type II courses (Lentz and Darling) apparently endeavor to make a differentiation in subject content between their two courses, those instructors teaching only one course feel impelled to include in it some of the content of both types of courses. For instance, Mrs. Fulcher who teaches what is clearly a course in bibliography has added automation, MEDLARS, etc. which constitute topics taught by instructors of the Type I courses.

(c) Type III Courses--Specialty Courses

Analysis of course structure and content reveals the existence of a third group of courses in which the principal emphasis is neither to provide a general introduction nor to furnish instruction in bibliography, but rather to explicate some specialized aspect of medical librarianship. In effect, they constitute instruction in depth within a library specialty.

Robert Cheshier at Case Western Reserve has designed, in connection with the Training Program in Medical Librarianship, a course entitled "Organization of Medical Practice

Table 6

Content of Type II Courses--Medical Bibliography

TOPICS	INSTRUCTORS				
	Lentz	Meckel	Darling	Connor	Fulcher
Preclinical Sciences	X	X	X	X	X
Clinical Sciences	X	X	X	X	X
History of Medicine	X			X	X
Allied Health Professions (Nursing, etc.)	X	X		X	X
Abstracts, Indexes, Translations	X	X	X	X	X
Reference and Compiling of Bibliographies	X	X	X	X	X
Automation					X
Terminology	X	X	X	X	X
Drug Information		X			X
Cataloging, Classification			X	X	X
MEDLARS, NLM			X	X	X
Communication in Medicine			X		X
Medical Statistics		X			X

and Research" (Appendix 1). The purpose of the course is "to acquaint students with the environment of the health sciences and the personnel working in that environment; to describe the structure of medical institutions and practice; and to portray the role of the librarian within the total system of communication in biomedicine." Topics covered include structure of the medical profession, role of the physician, physician-patient relationship, physician-hospital relationship, specialization in medicine, the allied health professions, team approach to health care, community medicine, medicine and the behavioral sciences, professional health education, flow of information within the health community. Guest lecturers are prominent physicians and medical educators at the Case Western Reserve University School of Medicine.

George Ember, also at Case Western Reserve University, has developed a course called, "Medical Subject Analysis and Searching" (Appendix 2). This course also forms part of the newly established Training Program. Emphasis is placed on the cataloging, classification, indexing, and search processes rather than on review of bibliographic tools. The purpose is "to develop an understanding of the principles, problems and procedures involved in subject analysis and searching by means of a workshop-type course requiring the participation of students in cataloging and classification of books, indexing of periodicals, question analysis, and searching."

It is evident that at the present time, education for medical librarianship consists largely of courses which are introductory in nature or which are oriented towards medical bibliography. The reasons are plain from the history given above. MLA accreditation has been given for both types of courses. But one or two courses in a library specialty does not constitute a curriculum. In the words of the Herner Report, "One course in medical bibliography does not a medical librarian make." The Report argued that the MLA accredited courses "range from fair to uninspired," and could find words of praise only for the educational programs at UCLA and Columbia. The conclusion reached was that the courses were "deficient in substantive biomedical subject content, unresponsive to the needs of biomedical and scientific research, almost wholly humanities and 'public library' oriented, and their sponsors only grudgingly aware of the necessity for newer documentation techniques."

In our estimation the Herner conclusions are unwarranted. The authors are confused as to the difference between courses, training programs, and curricula, and use all three terms interchangeably. Furthermore, specialization in medical librarianship is seen only to involve courses in information science. Extra servings of information science do not necessarily nourish the education-starved potential medical librarian. Our conclusion is that the quality of education in medical librarianship is excellent; the deficiencies are related to the extent of specialization at present provided within library school curricula.

#### IV. Proposed Design of a Specialized Educational Program in Medical Librarianship

Specialization within librarianship is both possible and desirable. This is not to argue that the objective of library schools should be to train individuals for narrow specialties within librarianship; rather the principal purpose should be to train individuals to think analytically, comparatively, and creatively with respect to the practice of librarianship. Any conception of specialization should be viewed within this context. The design of specialized library education must be based upon a carefully structured sequence of courses which encompasses the essential principles of librarianship. The provision of such a fundamental frame of reference is most likely to lead to judicious and prudent application of library principles and techniques in the various areas of librarianship. Specialized training can be carefully articulated within this basic instruction by the institution of courses and seminars in the specialty and the provision of field work and field trips by way of "clinical" experience. Such specialization in library education must surely come in the very near future, since "the concept of a librarian as



a single entity, a uniform product, equally competent in all aspects of the profession is now completely outmoded. Like hospitals, libraries and institutions are now demanding a broad range of skills, many of them highly technical and deserving of specialized training in their own right." <sup>6</sup> Some middle way must be found between educating for rigid, narrow specializations and the training of a generic species of librarian ill-equipped to practice in any type of library, subject field, or environment.

A model for specialization in medical librarianship is diagrammatically illustrated in Figure 1. It is suggested that this model is generalizable to other branches of librarianship such as law librarianship.

This model identifies four areas of knowledge required for the practice of medical librarianship, which are reflected in the curriculum design:

- Area 1. Basic Principles and Techniques of Librarianship
- Area 2. Structure, Organization and Management of Medical Library Resources, Facilities and Technology
- Area 3. Subject Content of Biomedicine (including Terminology)
- Area 4. Environmental Setting of Medical Practice, Medical Education and Medical Research

Areas 1 and 2 have for decades been recognized as the educational responsibility of library schools. Every course in medical librarianship embedded in a library school curriculum provides the essential groundwork of knowledge in these areas. However, the latter two areas--subject content and environmental setting--have not been adequately structured and taught as an integral part of medical librarianship.

Emphasis on the techniques of medical library practice has obscured the fact that the interpretation of library principles and concepts in terms of biomedical communication is the essence of training for medical librarianship. More than knowledge of library tools and techniques is required. The medical librarian is part of a swiftly changing environment, and cannot remain unaware of such trends as the accelerated rate of scientific advances in medicine, the higher level of health care expectation, the greater specialization in medical practice, the dramatic development of technological innovation, the growing institutionalization of health care, and the increasing reliance on the team approach. Faced with such a changing environment in medical practice, research, and education, medical librarianship is presented with a challenge of unprecedented magnitude. It is vitally necessary that the library schools provide a sound theoretical and informational base, both broad and deep, which will prepare the graduate to take his place as a valuable member of the health care team. He must be able to meet his colleagues--physicians, educators, researchers--as their intellectual equal, confident that his specialized knowledge and competence in his own field are in all respects equal to theirs.

Figure 1

Diagrammatic Model of Medical Librarianship

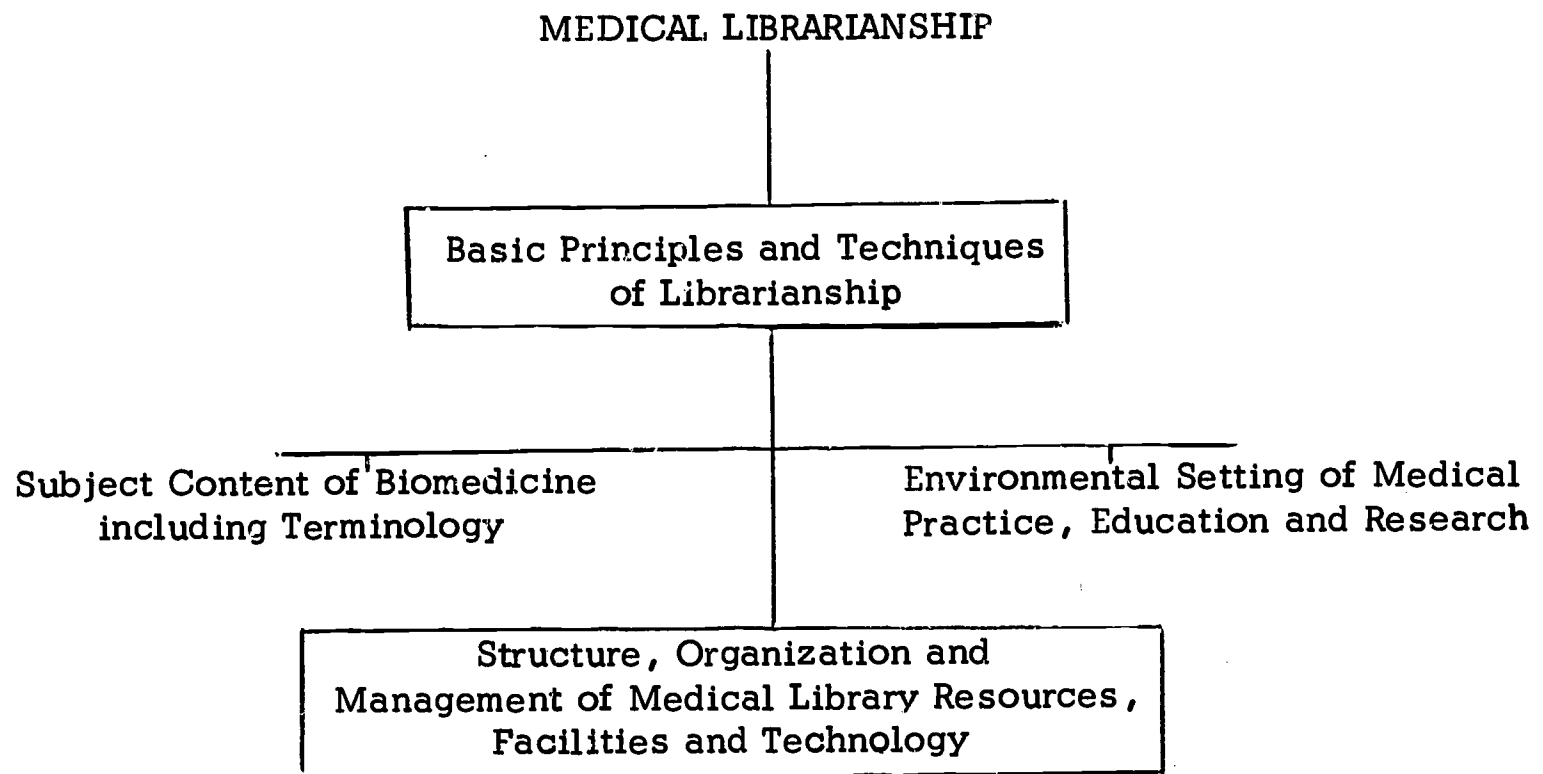

For this reason medical librarians must possess knowledge of both the subject content of biomedicine and its environmental settings. The medical librarian must understand who the physician is and what he does, what social and institutional pressures and restrictions influence his decisions and his actions, perhaps even what kind of education he receives; only then can he meet the physician's information needs with effective library service. The medical librarian must understand the advantages and handicaps of institutionalized health care, both in its broad social aspects and in the day-to-day routines within individual institutions; only then can he translate the details of his budget into efficient library operation. The medical librarian must understand the relation of research to practice, not only in his own field, but also in medicine. He must know what resources--conventional and non-conventional--are available to him and to his clientele, not only in his own field, but also in medicine. He must be aware of the communications network operating not only in his own field, but also in medicine.

Provision of instruction in the four areas described above presents a challenge to medical library educators. The basic principles and techniques of general library practice are obviously already an integral part of library school curricula. Teaching of the structure and organization of medical library practice requires the participation of medical librarians with operational responsibilities, since most library school faculty lack experience and involvement in such specialized practice. Knowledge of the subject content of medicine and of its environmental settings is best provided by medical school personnel as is done in some library schools. The implications of these several requirements are that education for medical librarianship is particularly rich and comprehensive when library schools enter into cooperative arrangements with biomedical libraries and medical schools. Moreover, the involvement of medical school faculty is particularly fruitful from a pedagogic point of view in that many of the problems faced by library educators have already been defined and explored by such medical school educators as T. Hale Ham, M.D., George Miller, M.D. and others.

The type of specialization structured above is already being implemented at Case Western Reserve University in the Training Program for Medical Librarianship and Health Science Information sponsored by the Public Health Service, Extramural Program of the National Library of Medicine. This involves participation by a consortium of the Library School, Center for Documentation and Communication Research, the Cleveland Health Sciences Library, and the School of Medicine. However, it is not our purpose to describe this program within this paper.

Education in medical librarianship along the lines suggested should be provided at several levels. In addition to courses offered as part of the M.S. in L.S. curriculum, mention should be made of the post-master's internship. It is obvious that the educational experience outlined above cannot be confined to a classroom. Student involvement in the working environment of medical libraries is essential, and although some field work is possible within the M.S. in L.S. curriculum, it is only within an internship that real participation in a "clinical" environment is possible. The internship is a useful educational instrument in that it offers a structured working environment and a wide range of experience. The relationship between internships and the formal M.S. programs must be



clearly defined, and close cooperation between the library schools and the "field" is essential, for it is obviously the responsibility of the practitioners to provide the environmental settings for internships.

At yet another level of education--the Ph.D.--it is possible at present to investigate a research topic in medical librarianship at any library school offering a Ph.D. program. It is, however, safe to predict that Ph.D. programs in biomedical communication will be established, and there is no reason why such programs should not be located in schools of librarianship. This will be the case only if a very broad view is taken of medical librarianship as a specialty within library schools. The same may be said with regard to specialization in other fields of library science. It is to be presumed that the future teachers, researchers and leaders in medical librarianship will be derived from the Ph.D. programs.

Finally, medical library education must also be provided at the level of continuing education. This involves not only the provision of short courses, institutes, seminars and the like, but also diagnosis of the educational needs of medical library practitioners. Programs for continuing education cannot be designed in the same manner as courses which are part of a formal curriculum. Before really effective continuing education can be established, it will be necessary to explore what medical library practitioners currently do and how well they do it. We stand in urgent need of performance standards, measures of performance, and development of measuring instruments. If the objective of continuing education is to upgrade library practice, it is obviously essential to be able to measure the impact of alternative modes of continuing education. The process of continuing education is more complicated than the simple transfer of information from educator to practitioner. As George Miller has expressed it: "Continuing education should mean continuing self-education, not continuing instruction."<sup>7</sup> The ramifications of these somewhat philosophical considerations have yet to be explicated in terms of education for medical librarianship, though a beginning has been made by both the National Library of Medicine and the Medical Library Association.

## V. Conclusions

It is recommended that more intensive and structured programs in specialized medical library education be developed, and that such programs be developed by consortia of library schools, medical libraries, medical schools, and hospitals. Emphasis should be placed not only on the mechanics of medical library practice, but also on the subject content of the health sciences and on the structure of the health sciences environment. The responsibilities of library schools in education for medical librarianship should range from the M.S. in L.S. program to the Ph.D. level and to continuing education.

The educational programs discussed in this paper are designed to train librarians competent to perform complex professional functions in medical school libraries and other fairly large libraries. I do not anticipate that specialized programs in medical library education should train hospital librarians. At the risk of encroaching on Dr. Pings' paper, I must state my belief that the educational requirements of hospital librarians



are different from those of medical librarians working in medical school-type environments. In the former instance a thorough understanding of the operational structure of hospitals is essential. Moreover, the work of hospital librarians operating retail outlets linked with regional medical libraries will probably necessitate skills more of a technical than a professional nature.

There can be little doubt that technicians, library aides, clerical personnel, pages, and other non-professional supporting staff will be employed in increasing numbers in medical libraries. It is possible to predict that a few professional librarians in large library systems, medical and otherwise, will as department heads supervise large numbers of non-professional personnel. Such deployment of limited numbers of manpower is inevitable. Conservation of skilled professional manpower is also possible at the other end of the library hierarchy or career ladder. There is little justification for administrators of large library systems to be primarily librarians and only secondarily managers and administrative experts. In line with the precedent of professional hospital administrators, who are no longer required to be physicians, it can be argued that library administrators should be employed to manage complex library systems, leaving professional librarians free to practice librarianship at a high level.

The responsibilities of medical library educators to non-professional library education is of no small concern. The decision to employ increasing numbers of non-professional personnel for the performance of well defined and structured tasks requiring minimum judgment lies with the administrators of medical libraries. Library educators will watch the present Manpower Debates with great interest. I have no doubt that the most urgent need is to train professional medical librarians competent to perform at a high level of truly professional performance and able to supervise and educate non-professional personnel. The establishment of an élite, a cadre of highly trained professional librarians and educators, must receive the highest priority. This is not to say that the training of pages, clerks, library assistants, and other non-professional personnel involves no urgency. The most effective utilization of skilled professional manpower can only result from support provided by auxiliary personnel. It is suggested that professional librarians are the chicken and non-professional librarians the egg in this situation.

#### Special Acknowledgement:

The author is particularly grateful to the instructors of the referenced courses in medical librarianship for the course descriptions, syllabi, reading lists, and other materials which they so readily provided, and for their comments in private correspondence. Without their assistance, this paper could not have been written.

## REFERENCES

- <sup>1</sup>Alan M. Rees, "What We Should Teach Special Librarians," Special Libraries, LVIII (January, 1967), 33-36.
- <sup>2</sup>W. J. Bishop, "On the Medical Section and Its Work," "Library Association, Bournemouth Conference Papers and Discussion," in John L. Thornton, Selected Readings in the History of Librarianship (London: The Library Association, 1966), p. 390.
- <sup>3</sup>Margaret P. Russell, "Education and the Training of the Medical Librarian in Great Britain," Bulletin of the Medical Library Association, LII (January, 1964), 92.
- <sup>4</sup>Louise Darling, "Development of Training Programs in American Medical Libraries," Bulletin of the Medical Library Association, LI (July, 1963), 339-53.
- <sup>5</sup>Thomas Fleming, "Medical Librarianship, a Mid-Century Survey: A Symposium. Present Status and Future Possibilities of Education for Librarianship in the Medical Sciences," Bulletin of the Medical Library Association, XLV (October, 1957), 467-70.
- <sup>6</sup>Paul Van Riper, "The Dimensions of Manpower; Problems and Policies," Wilson Library Bulletin (April, 1967), 807.
- <sup>7</sup>George E. Miller, M.D., "Continuing Education for What?" Journal of Medical Education, XLII (April, 1967), 324.

## APPENDIX 1

### 1. ORGANIZATION OF MEDICAL PRACTICE AND RESEARCH (LS598)--

Case Western Reserve University  
School of Library Science  
Assistant Professor Robert G. Cheshier

a) Purpose:

"To acquaint students with the environment of the health sciences and with the people who work in that environment; to describe the structure of medical institutions and practice; to indicate the role of the librarian within the total system of communication in bio-medicine.

b) Organization:

The course consists of lectures by the instructor, supplemented by presentations by practicing physicians, medical educators, etc.

c) Content:

Structure of the Medical Profession  
Role of the Physician  
Physician-Patient Relationship  
Physician-Hospital Relationship  
Relationship between Medical Practice  
and Research  
Specialization in Medicine  
Allied Health Professions  
Team Approach to Health Care  
Community Medicine  
Medicine and the Behavioral Sciences  
Professional Health Education  
  
Flow of Information within the Health  
Community

Phillip Partington, M.D.  
Genevieve Miller, Ph.D.  
Robert Izant, M.D.  
Donald Glover, M.D.

T. Hale Ham, M.D.  
A. Benedict Schneider, M.D.  
Robert Cheshier  
Robert Cheshier  
Eugene Vayda, M.D.  
Andrew Dobelstein  
William Stickley, Ed.D. and  
Robert Cheshier  
Betty Mawardi, Ph.D. and  
Robert Cheshier

## APPENDIX 2

### 2. MEDICAL SUBJECT ANALYSIS AND SEARCHING (LS599)--

Case Western Reserve University  
School of Library Science  
Mr. George Ember, Instructor and  
Manager, Medical Information  
Projects, CWRU

a) Purpose:

"To develop an understanding of the principles, problems and procedures involved in subject analysis and searching by means of a workshop-type course requiring the participation of students in cataloging and classification of books, indexing of periodicals, question analysis and searching. "

b) Organization:

Three main areas of study: cataloging-classification schemes for books (5 weeks); indexing of citations, articles and non-book materials (2 weeks); reference service and searching (8 weeks)

c) Content:

- (i) Introduction
- (ii) Cataloging: DDC, LC, Boston, Cunningham, NLM
- (iii) Indexing: Authority lists--LC, ASTIA, SSS, MeSH
- (iv) Searching: Question analysis, search strategy, etc.



CURRICULUM CONTENT FOR EDUCATION IN MEDICAL LIBRARIANSHIP AT SEVERAL LEVELS  
by Alan M. Rees

Points from the Group Discussion

---

1. What background should be required as prerequisite for education as a health sciences librarian? Is a science major at either the graduate or undergraduate levels necessary, or is familiarity with subject content sufficient?
2. Medical school faculty must participate in training programs for the health sciences librarian.
3. Should library schools train library technicians as well as librarians? Should such training take place elsewhere?
4. To what degree must the health sciences librarian understand the environment in which he works? This understanding must be acquired either in an educational program or on the job if the librarian is to realize the library's goals in the context of its total environment.

SIXTH SESSION

TRENDS IN THE HEALTH SCIENCES: IMPLICATIONS FOR MEDICAL LIBRARIANSHIP

By

Charles R. Strother  
Professor, Psychology and Psychiatry  
Director, Mental Retardation and Child Development Center  
University of Washington  
Seattle, Washington

The invitation to participate in a conference on medical library education was unexpected. While I have been a user of medical libraries for a good many years, I have not previously had occasion to consider the medical library as an institution, the changes which it must undergo to meet changing needs, or the implications of these changes for the education of the medical librarian. I must confess that the reading which I have done in preparation for this meeting has been, to me, a disturbing revelation of the magnitude of the problems involved in the development of adequate medical information facilities. I had no conception of the appalling (no other word is quite adequate) lack of space, of books and of manpower, and only the typical user's awareness of the urgency of the need for better systems of cataloging, storage, retrieval and distribution of medical information.

The problem to which this conference is addressed--the training of the medical librarian--is a central one. The nature of the training programs which are provided will determine, to a considerable extent, the efficiency with which medical libraries function and their capacity to adapt to future needs. Future needs must be inferred from current trends. Medical practice, education and research are undergoing significant changes which will affect the nature of the demands placed on medical libraries. An understanding of these changes and a careful analysis of their implications for the structure and role of medical information services are essential to the development of the training programs for the medical librarian of the future.

My responsibility on the present program is to discuss some current trends in the health sciences and to comment on the implications of these trends for the training of medical librarians. I make no pretense to omniscience. Others may interpret current trends differently. You, as librarians, may see other implications than those which occur to me, as a non-librarian. Nevertheless, if this paper stimulates discussion of some of the needs which must be met by medical libraries, it will have served the intended purpose.

One of the most significant trends in the health sciences is the trend toward comprehensive medicine. This trend is clearly apparent in medical practice, in medical education and in medical research. In medical practice, it is reflected in the transition from solo practice and specialized institutions to systems and facilities that can provide comprehensive care. When medical care was provided principally by general practitioners, the individual physician was able to provide reasonably comprehensive care for his patients. He knew the patient's background, was concerned with the maintenance of his health over a span of years and was responsible for his care both during and after any illnesses or accidents. The rapid growth of medical science has led to an increasing degree of specialization in medical practice. While as recently as 1960 forty-five percent (45%) of physicians described themselves as engaged in general practice, only fifteen percent (15%) of recent medical school graduates planned to become general practitioners. Increased specialization has had a number of consequences: no one physician was responsible for total care of the patient; the concern of a given specialist was usually limited to the diagnosis and treatment of disorders of a single bodily organ or physiological system; and both the prevention of disease and the rehabilitation of the patient following illness or injury tended to be neglected. Recognition of these deficiencies has led to various efforts to provide for more comprehensive care. Perhaps the

clearest evidence of this trend is to be found in the field of mental health. Until quite recently, the available facilities consisted in private practitioners or community clinics providing outpatient treatment and private sanatoria or public mental hospitals providing twenty-four-hour care. Limited preventive services were provided by various social agencies; emergency care facilities were seldom available and little provision had been made for rehabilitation of the patient following hospitalization. A study of this system of care for mental illness, by a National Commission, has led to Federal and State programs for development of comprehensive community mental health centers which will not only coordinate separate facilities but will fill the gaps in present programs and provide the patient with continuity of care. The regional programs in heart disease, cancer and stroke are a further example of this trend toward comprehensive care. A recent conference sponsored by the Association of American Medical Colleges concluded: "The physician, with his colleagues in the [health-related] professions can no longer represent the spectrum of service for the promotion of health. He must collaborate with social scientists, economists, community planners, anthropologists, social psychologists, engineers and a host of other disciplines to provide for society the entire range of . . . preventive and therapeutic measures."<sup>1</sup>

Recognition of the need for comprehensive care is indicative of a fundamental change in concepts of health and illness. To oversimplify, if disease is conceived to be a pathological change in some tissue, organ or system, brought about by some specific pathogenic agent, then diagnosis and treatment by a physician who has specialized in this aspect of medicine constitutes an adequate system of care. Unfortunately (from this point of view), the diseased organ is attached to a patient and the patient, in turn, lives in a particular environment and is part of a complex social system, which may have as much or more to do with the onset and course of his disease and the outcome of treatment as any specific pathogenic agent. "The factors that 'cause' disease in this more complex and fundamental sense," says the report of a recent commission sponsored by the A.M.A., "will almost certainly not be found in the study of any one discipline. . . . The cause may be a pattern or combination of chemical, biological, psychological, sociological, environmental and developmental variables."<sup>2</sup> Comprehensive medicine, consequently, requires an understanding of psychological and social factors involved in health and illness. The A.M.A. Commission on Graduate Medical Education points out that: "What is needed--and what the medical schools and teaching hospitals must try to develop--is a body of information and general principles concerning man as a whole and man in society. . . . This background will be partly biological, partly it will be social and humanistic, for it will deal with man as a total, complex, integrated, social being."<sup>3</sup> Medical school curricula are beginning to reflect this broader concept of the factors affecting health and illness. NIMH grants for the establishment of behavioral science programs in medical schools, for example, increased from 5 in 1960 to 22 in 1964. Not only is the medical school curriculum being expanded to include material from the social and behavioral sciences but students from these disciplines are coming into the medical school--and into the medical library--in increasing numbers. In the University of Washington, which is not altogether typical but which is representative of this trend, the number of students from the College of Arts and Sciences who are enrolled in courses in Health Sciences exceeds the number of undergraduate medical students enrolled (483:315).



This holistic approach to problems of health and illness is also reflected in a greatly increased amount of multidisciplinary research. Behavioral and social scientists are being added to the teams of biological and physical scientists employed in health science laboratories. In fact, the President's Commission on Heart Disease, Cancer and Stroke considered the acceleration of interdisciplinary effort to be one of the major factors underlying communication problems in the health sciences.<sup>4</sup>

The trend toward comprehensive medicine is evident in medical practice, in medical education and in medical research. It has, I think, very clear implications for the medical library and for the training of medical librarians. Obviously, the range of literature which must be made available to the medical student, the practitioner and the research scientist must be broadened to encompass an increasing number of related disciplines which have not heretofore been included in medical collections. Practitioners, students and research workers from many non-medical fields will look to the libraries which serve colleagues in the health sciences to meet their needs, too. To meet these needs the staffs of medical libraries must include librarians familiar with the literature in the behavioral and social sciences.

A second important trend in the health sciences which has implications for medical librarians is the trend toward larger and more complex systems of health care. To some extent this is a direct consequence of the trend toward comprehensive medicine, which requires coordination of the various special services and special facilities which are involved in comprehensive care. However, as recently as two or three years ago, Federal support for the development of comprehensive care programs was restricted to particular categories of disease; for example, to the development of comprehensive mental health centers or to regional centers for heart disease, cancer and stroke. More recently, emphasis has shifted toward more comprehensive planning for health care. Most states are now in the process of establishing planning agencies which will attempt to coordinate the development of all of the health care facilities in a given area. Categorical centers are thus to be incorporated into a more comprehensive system. As a more comprehensive system develops and as practitioners, clinics, hospitals and medical centers which have heretofore functioned as separate (and often as isolated) facilities become more closely coordinated, it seems reasonable to expect that the separate library facilities which have been maintained by these agencies will become more closely interrelated. This, together with the tremendous increase in the amount and scope of the literature relevant to medicine, which has made it impossible for most local libraries to maintain an adequate collection, inevitably results in the need for large, centralized medical library facilities. This need has been recognized in the establishment of the National Library of Medicine, in the development of Medlars and in the Regional Medical Libraries program.

There are two implications of this trend on which I would like to comment briefly. One implication is the necessity for a systems approach to the planning and operation of medical information facilities. Medical library staffs in the future must include people who are familiar with systems analysis and with systems design. With the current emphasis on automation and the application of computer science to information systems,

there has been some tendency to overlook the fact that the type of information system with which the librarian must be concerned is necessarily a man-machine system in which the ultimate criterion of efficiency must be the degree to which the user is able to utilize the information which the system is capable of delivering. I should like to return later to the importance of an understanding of the needs of the user of medical information.

A second implication of the trend toward large and complex systems is the necessity for redefining old roles and developing new ones. As institutions change, staff functions must change. As the medical library system becomes larger and more complex, staff functions will tend to become more specialized. Present roles will change and new roles will develop. I am impressed by the extent to which these changes are reflected in current training programs. Mr. Fockler kindly made available to me descriptions of training programs for medical librarians and information specialists.<sup>5</sup> In reading these programs, it is apparent that several somewhat different roles are emerging. Some programs seem to be designed to train medical librarians in the more traditional library functions of acquisitions, cataloging, circulation, inter-library loans, public services and administration. Other programs appear to be directed primarily toward the training of information specialists (or communication scientists), with emphasis on computer science, systems analysis and design and information systems. At least one program, which was of particular interest to me, defines still a third role, which has been called "the interface between the medical scientist or practitioner and the information specialist." While I am not well enough informed to debate the relative merits of these particular role models, it would seem that the medical information systems of the future will require at least these, and possibly more, specialists and that training programs should be sufficiently flexible, or sufficiently diverse, to accommodate more than one model.

The third, and last, trend which I would like to discuss is usually referred to as the trend toward lifetime learning. As librarians, you are probably more acutely aware than the rest of us of the tremendous proliferation of clinical and scientific literature. It has been estimated that there are over 14,000 biomedical journals and that the current rate of production of biomedical literature exceeds five million pages a year. The particular consequence of this flood of information which concerns me here is its effects on the needs and habits of the reader of medical literature--the student, the practitioner and the researcher.

It has become manifestly impossible for the medical student to become reasonably familiar with the basic literature in all branches of medicine within the span of four years, yet the need for access to this growing body of literature is greater than ever before. The solution to this dilemma is being sought in two ways: by changes in teaching methods and curricula in the medical school and by increasing emphasis on postgraduate education. In the medical school, emphasis is being shifted from an attempt to cram more and more information into the curriculum to attempts to teach the student how to find and organize the information he needs (what the psychologist calls "learning to learn"). A recent Teaching Institute, sponsored by the Association of American Medical



Colleges, concluded that: "The 'new look' in medical education calls for the development of teaching and learning methods that are calculated . . . to inculcate in the student the ability to select, organize and evaluate information . . ." <sup>6</sup> The student in the future will spend a great deal more time in independent learning--in personal dialogue with an information system which will give him ready access not only to the formal literature but to an increasing range and variety of teaching materials made possible by new audio-visual techniques. The medical library must respond to this demand and staff must be trained to assist the student in the use of a complex information system.

The needs of the practitioner for access to the information system are no less acute than the needs of the student. Both the amount of information that cannot be crowded into the formal curriculum and the rapid rate of obsolescence of medical knowledge make continuing education "a categorical imperative of contemporary medicine." <sup>7</sup> The urgency of this problem is attested to by two recent studies, commissioned by the A.M.A.: the Dryer report on "Lifetime Learning for Physicians" <sup>8</sup> and the "Report of the Citizen's Commission on Graduate Medical Education." <sup>9</sup> These reports make it clear that the practitioner, as well as the student, will place increasing demands on the medical library system. These demands will be for two sorts of information: refresher information of a more general nature; and information specific to a clinical problem. (This will, incidentally, pose some difficult technical problems of indexing, since there is an inverse relationship between comprehensiveness and relevancy.) The refresher information required by the practitioner does not differ significantly from the information needed by the medical student but clinical information, to be useful, must meet additional demands--it must be highly relevant to the clinician's problem and it must be made available to him promptly and at a convenient place.

Of the continuing need of the researcher for access to the information system, little need be said. Continual search of the literature is an essential part of his work. However, the body of literature has grown so large that it is seldom possible for the research worker, without assistance, to maintain access to much that is relevant to his problems. One recent study has shown that a significant proportion of pertinent material was not known to a sample of competent investigators. The waste involved in unnecessary replication of research, as a consequence of this lack of information, has often been deplored. The solution to the problem lies, in part, in a more efficient and economical information system but, even with such a system available, there will undoubtedly be an important role for someone to serve as an "interface" between the research worker and the system. This will, of course, require some familiarity with the particular area of research and thus create positions for librarians (or information specialists) who have had substantial background in various behavioral and social science fields as well as for those with a background in physical or biological sciences.

There are, of course, other trends in the health sciences which are of relevance to medical librarianship. I have chosen to discuss here some which are more directly related to the discipline of medicine but what has been said is, I believe, also applicable to the other health sciences, to the paramedical professions and, at least in part, to graduate education in the behavioral and social sciences.

In summary, I have discussed three trends: (1) the trend toward comprehensive medicine; (2) the trend toward the development of systems of health care; and (3) the trend toward lifetime learning. The principal implication for medical librarianship of the trend toward comprehensive medicine is that the librarian must be familiar with a much broader range of literature than has traditionally been included in the medical library. The development of coordinated systems of health care will necessitate the coordination of health information facilities which has already begun under the National Library of Medicine. Such a system will create new roles for medical librarians. Training programs must prepare for a diversity of functions. Finally, the needs of the users of the medical library are changing. The librarian must have sufficient understanding of the needs of the student, the practitioner and the researcher--of the physical, the biological, the social and of the behavioral scientist--to enable them to utilize effectively a very large and complex medical information system.



## REFERENCES

- <sup>1</sup>Lowell T. Coggeshall, Planning for Medical Progress Through Education, A Report of the Executive Council of the Association of American Medical Colleges (Evanston, Illinois: Association of American Medical Colleges, 1965), p. 39.
- <sup>2</sup>The Graduate Education of Physicians, Report of the Citizen's Committee on Graduate Medical Education (Chicago: American Medical Association, 1966), pp. 80-81.
- <sup>3</sup>Ibid, p. 52.
- <sup>4</sup>President's Committee on Heart Disease, Cancer and Stroke, A National Program to Conquer Heart Disease, Cancer and Stroke, A Report to the President (Washington, D. C.: U. S. Government Printing Office, 1965), II, p. 389.
- <sup>5a</sup>• Marilyn Bracken and C. W. Schilling, Education and Training of Information Specialists in the U.S.A. (Washington, D. C.: George Washington University, 1966).  
  
b. Herbert Fockler, Private communication, 1967.
- <sup>6</sup>Stuart G. Wolf, Jr. and Darley Ward, "Medical Education and Practice: Relationships and Responsibilities in a Changing Society," Journal of Medical Education XL (1965), pt. 2, p. 95.
- <sup>7</sup>President's Committee on Heart Disease, Cancer and Stroke, op. cit., p. 405.
- <sup>8</sup>Lifetime Learning for Physicians: Principles, Practices and Proposals (Cleveland, Ohio: Joint Study Commission on Continuing Medical Education, 1962).
- <sup>9</sup>The Graduate Education of Physicians, op. cit.

TRENDS IN THE HEALTH SCIENCES; IMPLICATIONS FOR MEDICAL LIBRARIANSHIP  
by Dr. Charles R. Strother

Points from the Group Discussion

---

1. The rate at which skills and knowledge become obsolete is increasing.
2. Two positions can be taken in adapting to this change:
  - A. The conservative position, in which one can (1) reject change and attempt to preserve the status quo; or, (2) claim that it is impossible to predict change.
  - B. The liberal position, in which one can argue that certain directions of change can be identified, certain trends can be predicted, and that it is possible to develop training programs which will prepare individuals for change.
3. If the student is given an historical approach to the field of health sciences, and a socio-psychological approach to an analysis of the dynamics of change, he is better prepared to accept change, to understand its implications for himself and to know how to adapt to it constructively rather than defensively.
4. What is the relationship between the generalist and the specialist? The structure of health sciences information, in the broadest sense, makes necessary the definition of several specialist roles, namely:
  1. The computer specialist--involved with the hardware and technology of the computer.
  2. The information specialist--directed toward the processing of information rather than documents.
  3. The interface--the connection between the user and the information system.and the generalist--the administrator.
5. In the development of educational programs, recognition should be given to the diversity of needs and the diversity of roles to be filled in future information systems. To what extent is there a generic core common to these roles; to what extent must a specialized program be developed?
6. In transitional stages it is necessary to anticipate and to tolerate a great deal of ambiguity and fluidity in the definition of various roles.
7. What should be the subject preparation? The more the student knows about the subject matter the more capable he will be. However, this subject background can be acquired, building upon the ability to think analytically, motivation and capability for further study, and personality.

SEVENTH SESSION

EDUCATIONAL PROGRAMS FOR HOSPITAL HEALTH SCIENCE LIBRARIANS

By

Vern M. Pings  
Medical Librarian  
Wayne State University  
Detroit, Michigan

At one time the Medical Library Association was dominated by physicians. As the leadership for the Association was taken over by librarians, the concept of what medical librarianship should be was formed from the operation of academic medical libraries and large medical society libraries. Ballard remarked in 1925,

In my opinion it is not necessary for a medical librarian to be a physician, at times it is a serious handicap. The average physician is not an executive or an administrator. The head of the reference and research department may be a physician to the advantage of the position provided he has the other necessary qualifications.<sup>1</sup>

Even though education for librarianship has evolved so that it now carries a semblance of academic status, practicing medical librarians have insisted that whatever education is acquired in library schools, additional education is needed to be a good medical librarian. Nevertheless, medical librarianship as we conceive it today is based on functions and purposes of the less than 200 academic and large medical libraries which consider the physician as their primary user. Within the last 30 years the physicians' need for library service has grown and other sources of library service have had to develop besides that which could be given from the nation's few medical resource libraries. Health care and research now employ a complex of professional people and technicians all of whom need access to the scholarly record. Certainly, the health resource libraries need well educated people to man them. The education of a scholarly group of medical librarians who can provide us with intellectual and administrative leadership involving biomedical communication problems is a basic assumption to the thesis of this paper. However, let my point be clear: if we are only concerned with educating a few more individuals to do better work in the resource libraries, we have missed the challenge of medical librarianship. The pressing need for library service lies outside the large academic medical center--a kind of library service that is qualitatively different from that practiced in the resource libraries simply because the priorities of the users are different. The indictment is that our libraries as institutions have not kept pace with the changes in the ways health care is given and in the ways health knowledge is taught. A new social, economic, and academic structure has been created in one generation. Our old attitudes and techniques of medical library service cannot be stretched to incorporate this new structure.

### The Hospital

Our daily, as well as our scholarly press, constantly reminds us of growth of biomedical research. The publicity of the research scientist has been so great that politicians have questioned whether the results of this effort are being sufficiently utilized. The application of scientific knowledge to health problems has to take place somewhere; an environment has to exist to which individuals can bring their health problems to be diagnosed and where therapeutic decisions can be made and actions carried out. The hospital has become the central institution through which medical care, research, and professional health education is directed. The importance of the hospital in our society



might be judged by the fact that if all the dollars are added up that go to support the functions of these institutions, then this becomes the nation's major industry--an industry where knowledge is sold and services performed. There are no tangible production units, only the hope for improved health.

Today some people now think of the hospital as the first place to go when they are sick. Half a lifetime ago it was thought of as the last place to go. This change in attitude by society reflects a change in hospital function as well as causing further changes in that function. As with any institution, the environment forms the organization. Freidson remarks,

We can follow the founding, governing, reform, or decline of hospitals, not as something mysteriously proceeding from within organizations themselves. . . , but as something reflecting the demands made on them by the political and economic forces of the community . . . in fact, hospitals are likely in part to make themselves into the image they believe is attractive to the community and, in part, to persuade the community that what they are is good and worthy of support.<sup>2</sup>

It is my conviction that the purpose of the hospital health science library is different from resource medical libraries because of the organization of the environment in which it functions. No serious discussion on the education of the hospital health science librarians can be undertaken until and unless there is an appreciation of this hospital environment.

No adequate model of a modern hospital has yet been described but it is a relatively simple matter to demonstrate how profound are some of the changes over a period of time. One of the most obvious is the increase in the number of medical and technical personnel required by a hospital in the application of scientific knowledge. In 1939 Dochez contrasted the history of two patients in the same hospital with similar types of heart disease, however one was a patient in 1908 and the other in 1938. The medical record of the first patient was two and a half pages which constituted the combined observations of the attending physician, a house officer, a consultant, and a pathologist-bacteriologist. The medical record of the second patient who was still in the hospital when Dochez made his observation already comprised 29 pages with notes recorded by three visiting physicians, two residents, three house officers, 10 specialists, and 14 technicians, a total of 32 people.<sup>3</sup> The number of individuals who will be evaluating a similar patient in 1968 will have increased considerably.

A hospital can be visualized as a professionalized locale--a geographical site where persons drawn from different professions come together to carry out their respective purposes. Each professional group has received different kinds of training and each occupies some differential hierarchial position at the hospital while playing a different part in its total division of labor. This is indeed an oversimplified picture because the persons within each professional group are at different stages in their respective careers.

If one were to trace the educational routes of each individual one would find that they would all differ. Even those who belong to the same profession may differ quite measurably in the training they have received, as well as in the theoretical or ideological position they take toward important issues like etiology, treatment, and nursing actions.<sup>4</sup>

The increase in size and complexity of hospitals has come about from socio-economic factors as well as from the development of scientific medicine. Entirely new services have been created and old organizational patterns altered. One dramatic example of the evolution of new services requiring the alteration of hospital functions and responsibilities is emergency or outpatient departments. A study in Rochester, New York, showed that in 1963 the total number of visits to six hospital emergency departments equaled one-fifth of the total population of the entire county.<sup>5</sup> Various reasons have been ascribed to this phenomenon.

1) Patients have learned that a physician is available in hospital emergency departments and that he can go for care at his convenience rather than struggling for an office appointment which often may be weeks away.

2) Improved transportation makes patients more mobile and less dependent upon house calls.

3) Because of the mobility of our population families may need medical attention before they have established contact with a physician; the hospital is an obvious answer to this difficulty.

4) In some instances the cost of hospital emergency service may be lower than the cost of the care given in a physician's office.

5) Many medical insurances will cover hospital emergency services, but they will not pay for office or house calls.

6) Furthermore, physicians are increasingly referring patients to emergency and outpatient departments where diagnostic facilities and personnel are available.<sup>6</sup>

The reason for using this example is to emphasize that the hospital is being accepted, even by physicians, as the site and source of health care. Most of us will view the white coated scientist in his ivory tower academic environment as a part of the world over which we have little control and hence little interest. The hospital, on the other hand, has become part of the experience of nearly all of us. We want and expect, if not demand, that the best scientific knowledge be applied to our health problems. Ultimately, there are but two sources for scientific health knowledge, that stored in the minds of our scientists, physicians, and other professionals and that stored in the scholarly record.

Before discussing the utilization of the scholarly record there is still another aspect of the change in the function of the hospital. The hospital has become the major teaching environment for the health professions. Indeed, nurses, physical therapists, cytotechnologists and many other groups have formalized their education through association with a college or university, but rarely is a degree given until the student has spent a certain amount of time working and studying in a clinical environment. The teaching function of a hospital can be easily demonstrated in physician education. In 1945 there were two medical students for each intern and resident. By 1955 there were as many interns and residents as there were students registered in medical schools. Today there are four individuals in postgraduate medical education for every three medical students.<sup>7</sup> Whether the educational programs to be organized under the Regional Medical Programs will utilize the hospital environment is yet to be determined, but certainly it will not be ignored.

#### Availability of Hospital Health Science Library Service

The history and evolution of the hospital health science library has yet to be written, perhaps because it still has not been recognized as serving a distinct function in the total communication process of health care. But as Babcock remarks, all hospitals, regardless of size, must have a library for the protection of the patient and to help the physician.<sup>8</sup>

To say that all hospitals must have a library does not make it so in our real statistical world. A survey undertaken in September, 1962 revealed that of the 5,444 short-term, non-federal hospitals, only 3,192 (or 60%) were estimated to have a health science library.<sup>9</sup> Unfortunately, this survey did not define a hospital health science library with sufficient precision to determine how many of these 3,200 hospitals called a room with a few books stored in it a library. A study is now underway to assess how many of the physicians of metropolitan Detroit actually have library service. It is known that of 79 hospitals of the study only eight admit to possessing no library of any kind; another 37 indicate that their library is part of, or under the supervision of, the medical records department; the remainder (45%) of the institutions state the health science library is a separate facility. However, only 41 of the 71 hospitals with libraries have a full-time person assigned to library service. Since no standard of performance has been developed by any accrediting or other agency for a hospital health science library, a simple criterion for judging whether the library is actually providing service to the health profession is to determine if it is organized to provide access to the scholarly record through an interlibrary loan service. From data collected from several sources, 32 of the 71 hospital health science libraries were identified as borrowing materials from other libraries. Interestingly, 1,455 (52%) of the 2,754 members of the Wayne County Medical Society have attending appointments in these 32 hospitals and another 698 (27%) have other than full privileges. Thus, if it can be assumed that any interlibrary loan activity is the same as good library service, then one can conclude that the potential exists that almost 80% of the Wayne County Medical Society members have library service available to them.<sup>10</sup>



One might argue that any physician located in a metropolitan area if he takes the time, that is, if he is motivated enough, has access to library service since some institution in the area will be sufficiently public spirited to extend its services to qualified users. Not all physicians and hospitals are located in metropolitan areas. In the four state area, Indiana, Kentucky, Michigan, and Ohio, the American Medical Association reports that there are 31,833 non-federal physicians of whom 26,847 are located in metropolitan areas with a population of 70,000 or more. Only 342 of the four states' 614 non-federal hospitals are located in these metropolitan areas.<sup>11</sup>

Although the data available on hospital health science libraries and on the distribution of physicians are not adequate to describe what library services are available on a nation wide basis for physicians, it is clear that there are more than just a few physicians who have no library service and that many hospitals are not equipped, even though they have a room called a library, to provide access to the scholarly record. If it is true, as Babcock says, that a physician must have library service, then someone must assume the responsibility for developing a service which can reach all the nation's physicians.

Another dimension has to be added. The physician is the most mobile of all the health professionals; that is, his daily work may carry him to several hospitals and other institutions and agencies during the week. He has an opportunity to utilize the library facility that may be available at any one of these institutions. But no other health professional has this mobility. His work is confined to one institution. If no library service is available in that institution, either because there is no library or because he is denied access to the library services that do exist (not an uncommon situation), access to the scholarly record is limited to only what he purchases for his personal library. The number of health professionals, other than physicians, who have no library service available to them is unknown. Would you believe 1,000,000?

This paper is to be on education of hospital health science librarians. The objective of the discussion to this point has been to argue that

- 1) There is a large unmet need for health science library service.

- 2) The few resource libraries of the nation are unable, simply because of the geographic distribution of health professionals, to give direct service to those who now do not have access to a library.

- 3) Because the hospital is our major health institution, it must support a library service for health care and for professional health education.

A point made earlier is that the academic oriented health science library is a poor model on which to design a hospital health science library. If a hospital health science library does have a different function to perform than a resource library, then these differences must be included in the curriculum content for medical librarianship. Because of the large unmet need for hospital health science library service, there is little hope that



professional medical librarians can be found to fill existing vacancies, much less fill positions that should be created within the next 10 years. Other sources of manpower are therefore going to have to be tapped rather than library school graduates. Because of the specialized nature of the hospital health science library service, new educational and training programs are going to have to be created to prepare other than professional librarians to operate these libraries. The remainder of the paper is divided into three units (a) an intuitive and opinionated view of the function of a hospital health science library, (b) a review of existing educational programs for hospital health science librarians, and (c) recommendations for new kinds of educational programs which may help in preparing people to work in hospital health science libraries.

### The Function and Purpose of the Hospital Health Science Library

The use of the nominal compound, hospital health science library, even though cumbersome, has been deliberate. The simpler name, hospital library, has come to mean different functions to different groups. As already noted, the responsibility for maintaining the health science library is often given to the medical record librarian. Because of the growing complexity of hospitals several libraries may be maintained, one for patients, one for nurses, one for physicians, and one each for several of the large departments or research units in the hospital. The expense of maintaining these separate library units has been frequently questioned and the concept of the administrative unit, the integrated library, has developed. The division of labor in giving health care was previously emphasized, but the patient with his health problem is but one person. Perhaps professional groups can gain stature by insisting that they have a distinct literature which distinguishes them from other groups and which requires a separate library service. Health care today has to involve the combination of the knowledge and skills of many people. For this combination to function each professional group must have access to knowledge of the other groups. I do not wish to argue about what the best administrative arrangement should be for all hospitals, but I do wish to distinguish a specific library service which every hospital must have "for the protection of the patient and to help the physician." Johnson has recently defined this service administratively as "that department invested with the responsibility and authority to assure the hospital's educational, clinical, administrative, and research personnel of access to information which enables them to give the best patient care possible. . . ."<sup>12</sup> Individuals who are given the responsibility to provide access to the scholarly record to a diverse and highly educated professional group in a hospital environment must have special knowledge, skills, and above all, special motivation. The milieu these individuals create to fulfill this responsibility is the hospital health science library.

After this attempt to distinguish a particular kind of library service, I should now be able to list in a coherent fashion what functions it performs and how it is to be organized. Standards for hospital libraries have been prepared on several occasions and are again being revised by a Joint Committee on Hospital Libraries under the sponsorship of the American Library Association, Association of Hospital Institutional Libraries. When this Committee's report is complete, we may have a basis from which to design educational programs. At the moment I must extrapolate from my experiences as an academic medical librarian to describe what

hospital health science library service involves. My opinions have been arrived at by determining how and in what ways a hospital health science library is different from an academic medical library.

First, a hospital health science library should not have to carry the responsibility for preserving the scholarly record except insofar as it needs to preserve the archives of its own institution.

Second, the hospital health science library should not attempt to become a complete library, that is, to try to supply all the documents of all its users' needs from its own resources; or to say it still another way, emphasis should be placed on providing a service of access to the scholarly record rather than resource building.<sup>13</sup>

If these two general negative statements are applicable to a hospital health science library, many of the techniques that are necessary for the operation of a resource library are not applicable, or are at least less important, to a hospital health science library.

Please note that I have not said that a hospital health science library is less important than a resource library the operations of the two kinds of libraries are different. The one cannot be subordinated to another. All medical libraries have the ultimate purpose in providing a means to apply scientific knowledge to individual health problems. If this concept is lost, libraries become an end in themselves rather than socially useful institutions. Ontological arguments are frequently fruitless because it cannot be settled whether differences are unrelated or whether they are interdependent. In this age, or in any age, women are not less important or subordinate to men, but it is the difference between men and women that causes humanity to survive. Rude though the analogy be--the medical resource library and the hospital health science library are different; if we subordinate these differences, we shall lose the purpose of medical libraries. This point has been belabored first because I am firmly convinced of its validity, but more pragmatically, until medical librarians and educators recognize that the person who works in the rural community hospital health science library is just as important as if he worked in The Library in Bethesda, we shall never find enough people to educate who can man our nation's medical libraries.

It should be stressed that these negative policies (from a resource library's point of view) are pragmatic. Hospital space is expensive to build and maintain. Using this space to store little used library materials is difficult to rationalize when other institutions can do it better and cheaper. A hospital health science library is not an income producing department. The cost of maintenance must be added to the patient's bill. A balance must prevail between collecting and keeping library materials to serve as a means of access to the scholarly record against preserving collections which are unique so that their usefulness can only be justified if other institutions help support the cost of preserving them. If "completeness" is not a prime responsibility of the hospital health science library, other library operations become relatively more important.

1. The hospital health science librarian has to spend more time evaluating publications than does the acquisitions librarian in a resource library. The latter has the task of buying everything published which falls within the language and subject scope of the library's acquisition policies. The hospital health science librarian has but two choices available in selecting materials: learn enough about the content of the literature to make wise choices, or devise methods to allow the library's users to select materials.

2. The hospital health science librarian has to develop the opposite skill of selection, that of selecting for discard. Almost all library schools have a "book selection" course of some kind, even though poorly taught. Discard techniques are ignored perhaps because library educators assume all their students are to work in resource libraries.

3. Because the hospital health science library will have collections which consist of the most important and most used titles published, there is no need to engage in any detailed or elaborate cataloging and classification. Cataloging can be purchased from the services of our national libraries. The argument is today untenable that the hospital librarian must have sophisticated cataloging skills. Our national libraries have made it a policy to produce and to distribute cataloging information accurately and rapidly. If the hospital health science librarian finds these services inadequate, then it is the national libraries which must be informed so that they can improve their services. Any hospital health science librarian who insists that a uniquely developed cataloging system be maintained has lost a sense of the importance of his function.

4. Although sophisticated cataloging skills need not necessarily be one of the hospital health science librarian's qualifications, an appreciation and understanding of bibliographic techniques is vital. The library is to serve as an access point through which the entire scholarly record can be acquired for any qualified user.<sup>14</sup> Knowledge of the organization of resource libraries and how one locates and identifies specific documents is one of the most important skills the hospital health science librarian must possess. The interlibrary loan transaction is merely the reordering of the intellectual and bibliographic work that would have to be done if the document retrieval were done entirely in the resource library.

As the science of hospital health science librarianship develops, other distinctions can undoubtedly be made. Perhaps the exploration of the present state of medical library practice now underway at the Center for Documentation and Communication, Western Reserve University, will reveal in far more detail what hospital health science librarianship is and what it ought to be.

In most papers of this kind, one of the exercises that an author goes through is to try to describe the personal qualities the librarian should have. Some idea of the kind of person to be recruited would be helpful for the educators. If it is true, as I suggest, that hospital health science librarianship is a new library specialty, the kind of person to recruit is still unknown. We can hope that they will be intelligent, but we must be



wary that not too many are more intelligent than our present medical librarians and library science educators.

#### Existing Sources of Manpower and Training Programs

An accurate estimate of the number of hospital health science librarians there are and how many more are needed is not possible to make. A clearer picture of how many librarians are needed will be known when the American Hospital Association completes its survey on hospital libraries and when Joyce Malin completes her study on osteopathic hospital libraries. We do have some information, however. We know that there are over 7,000 hospitals in the nation and if the rest of the nation is as metropolitan Detroit, less than half have any full time staff member. We certainly know that only a small proportion of those who now operate the hospital health science libraries are graduate librarians. Furthermore, even if there were some biomedical communication czar who had the power to hire all the librarians who are to work in the hospital health science libraries, he would be helpless if he expected to replace all the existing staff with graduate librarians. Who are these non-professional librarians who are now operating hospital health science libraries? Of the 54 registrants at the Institute on Library Service held in Birmingham, Alabama, April 10-14, 1967, 46 had the following educational background.<sup>15</sup>

<u>Educational Background</u>	<u>Number</u>
No college and no professional education	21
Some college and no professional education	13
Some college and some professional education	8
Some college and no reply re professional education	1
No college and no reply re professional education	1
No college and some professional education (?)	1
No reply and no professional education	<u>1</u>
	46

When a hospital wants to establish a health science library service, the administrator or the library committee indeed has a difficult time to find a librarian. The people with a professional library degree who have an understanding of the hospital milieu, who are willing to isolate themselves from their professional colleagues, and who are willing to work for the salary most hospitals are able to offer are rare. The solution to the problem is to find someone already in the hospital who can be freed of his present tasks and convinced to take on the job of "running the library" and this is often the medical record librarian, or, to recruit someone, usually a woman with a college degree, whose



children are now in high school or college to take on the task of organizing the library.  
The innocent recruiting the innocent.

Without exaggerating, there are now hundreds of people working in hospital health science libraries who have been recruited in a manner similar to this. Very few have a clear conception of the basic library science techniques nor do they have any conception of the uniqueness and importance of their job. Certainly more professionally educated librarians have to become hospital health science librarians, but the task before the library profession is to provide those now working in the hospital health science libraries with an understanding of their function in relation to health care and access to the scholarly record. Library educators are also going to have to continue to face the responsibility to find a means of teaching those who will continue to be recruited by hospital administrators and library committees into this specialized area of medical librarianship.

The need for specialized education has been recognized but recently--the last 10 years. The Medical Library Association and its Regional groups have recognized that hospital health science librarians have special and specific problems. Workshops and day long programs have been prepared at meetings. So far as I can determine, no accredited library school has yet taken cognizance of the need for hospital health science librarians, either by undertaking a study of manpower needs or by developing any curriculum of study. The Immaculate Heart College in Los Angeles did set up a course in 1959 and the University of Alabama Extension Service offered a course in 1963.<sup>16</sup> The promoters of both these "courses" recognized that they would have to accept students without college degrees.

The recognition that a formal course was needed to inform, educate, and teach the person assigned to the hospital health science library came from the American Hospital Association. The leadership for the creation and success of the American Hospital Association's Institutes on Library Service rests on Helen Yast. She reported in June 1963 that 215 individuals from 36 states had graduated from the Institutes since the first one held in October 1959.<sup>17</sup> Many more have since received their certificates from the American Hospital Association's and the Catholic Hospital Association's Institutes. These institutes, rather than solving an educational problem, have only accentuated the need for more and different programs. Besides being unable to accommodate the number of people who wish to participate in these institutes, this approach for the education of hospital health science librarians has several insoluble difficulties:

- 1) The individuals participating do not have similar backgrounds and competence, nor do they come from similar institutions; time is spent relating differences during the study sessions rather than discussing common problems.

- 2) Instructors, because they are chosen anew for each institute, have little opportunity to coordinate their presentations; some topics will be discussed more than once, while other important ones are ignored.

3) Because the institutes have been given in various locations, they lack a stable environment from which to obtain feedback and continuity of operation.

4) Competent faculty for the institutes are difficult to find; because a person is a competent librarian does not automatically make him a good teacher.

The situation I am trying to describe can be summarized in the following way:

1) Hospitals need to employ many knowledgeable people who can operate health science libraries. Any estimate of the number of people needed is vague, but the number is in the hundreds.

2) Hundreds of people now working in hospital health science libraries, although intelligent and dedicated, have not had the background or training to develop an organization to obtain full access to the scholarly record for the professional staff the library is designed to serve.

3) There is no hope of finding graduate librarians to fill present posts available nor will library schools be able to graduate the necessary numbers, at least within the next few years. Furthermore, programs and courses now offered, or about to be offered, in library schools in medical librarianship overeducate the student for hospital health science librarianship; that is to say, the competition for them is so great in the expanding biomedical academic and resource libraries that hospitals have little chance to bid for their services.

4) The only organized educational program now existing is the Institute of Library Service co-sponsored by the American Hospital Association and the Catholic Hospital Association which, admirable though it be, lacks the necessary stability to establish health science librarianship as a distinct career goal.

#### Development of New Hospital Health Science Librarianship Educational Programs

There is only one institution that has the facility to sponsor and develop new hospital health science educational programs, the library school. The yet to be organized regional medical libraries under the Medical Library Assistance Act must have some kind of continuing education program if they are to function properly. Another possibility is for an educational program to be developed under the sponsorship of the Regional Medical Programs of the Heart, Stroke, Cancer, and Allied Diseases Program.

One institution that has been thought of as being able to educate future hospital health science librarians is the junior colleges. Many programs have been started to train the library technician.<sup>18</sup> The library profession has not fully accepted the concept of the library technician. In any event, the junior college library technician must still work under the supervision of a qualified librarian.<sup>19</sup> The hospital health science librarian, at least as I conceive of him, is not a technician. A library technician may indeed be

useful in the hospital environment, but the skills and attitudes needed are more sophisticated than those that can be taught to junior college students. The hospital health science librarian must work with the most highly and intensely educated group of any institution outside of academic and research organizations. I emphasize my position: I do believe that medical library technicians are needed to fill many positions, but a library technician produced under the current programs cannot be equated to a good hospital health science librarian. Either additional education has to be provided this technician or considerable experience is required before he can adequately take over the operation of a hospital health science library. To fill our hospitals with library technicians would only compound our problems in providing library service to the health professions.

Although the proper place for library education of all kinds is in library schools, the task of developing hospital health science librarianship training will require a cooperation between library schools and medical libraries that does not now exist. Just as the health care professional cannot practice without patients, librarians cannot be librarians without libraries. Library schools have undertaken many programs for the training and upgrading of public library and school library practitioners. Since library schools are in an academic institution, it is relatively easy, too easy according to some, to educate college and university librarians. One reason the Institutes on Library Service have been so successful has been that there is communication with the planners of these institutes with hospitals and their librarians. Before library schools can tackle the problems of hospital libraries, they must have the means to learn about needs and problems of these new kinds of specialized public libraries.

There will be over 50 regional medical programs established during the next few years each with one or more medical schools as a center and 10 regional libraries created within the next four years. Each will have a program which will extend to hospitals and other health related institutions. The success of these library programs will depend upon the resource libraries' ability to explain and to teach health science librarians of their usefulness. This must be more than a publicity program. Regular workshops or "courses" must be established for each of the regions. Library schools have the teachers, but very few of them are aware of and have experience in the specific skills and attitudes necessary to develop and to teach the curriculum for the education of hospital health science librarians. The resource and regional libraries may have staff who are knowledgeable about what ought to be taught, but these libraries do not have the administrative mechanisms to deal with the details necessary for preparing academic programs even if the staff were free to devote time to this kind of enterprise.

A new educational problem has developed and the question really is, who is to take the leadership to undertake this rather extensive educational endeavor. In my opinion, it ought to be the library schools simply because other professional schools have taken on the responsibilities to create new curricula and do the necessary investigations to formulate the requirements for growing professional groups, but insofar as I know there is no library school in the nation that has a faculty which is capable of developing the educational programs. Only a few have a faculty or the facilities to undertake the necessary investigative work to determine what kind and what quality of programs have to



be maintained. Sponsoring irregular workshops is no solution. The Institutes on Library Service are already in existence and are overwhelmed. Furthermore, I know of no library school (and very few resource libraries) which have accepted the hospital health science library as a legitimate object of study or even to admit of its importance in providing health care, except in a patronizing manner. If library schools do not accept this challenge, it will be resource and regional medical libraries which will have to take on the responsibility whether they want to or not. The best arrangement administratively would be if library schools and resource libraries would work together.

Before any real work can be accomplished in setting up a hospital health science education program teachers must be found. There is no point in any attempt to design curricula out of thin air--the participation of teachers is essential. Too much librarianship is reported in the literature as personal experience which this paper reflects. Any course outline I can suggest is based on my experience in one metropolitan area. The education of hospital health science librarians is a national enterprise. The only way a sound curriculum can evolve is through study of people and institutions. Would it be possible for library schools to develop teachers by first hiring them to do this investigative work?

### Summary

The development of health care has become complex and involved. Our health care and our biomedical research institutions have altered their structure in many ways to accommodate the change in quality and kind of health care. The hospital has undergone the most dramatic change. It is no longer a place for just the desperately ill, but has become a center for primary health care and simultaneously has grown into our major health care teaching institution. Good library service is essential in the hospital if the objective of health care is to be attained--the application of scientific knowledge to individual health problems.

At present there is no qualitative or quantitative standard for hospital health science library service. Perhaps because of this hospital health science librarianship has not been recognized by the library profession as being a distinct library specialty. Many of the individuals now employed as hospital health science librarians have had no formal education in library science and their only library experience is that gained in the institution in which they are now employed. The only ongoing programs now available specifically aimed at the education of hospital health science librarians are those sponsored by the American Hospital Association and the Catholic Hospital Association.

Recent federal legislation will make it mandatory that resource libraries extend their services and make their resources available to the hospital health professionals. Medical resource libraries will not be able to work effectively without knowledgeable people operating hospital health science libraries.

The conclusion seems clear that some agency must take the responsibility to develop a regular formal program for the education and training of the hundreds of people now in



hospital health science libraries and to prepare additional hundreds of people for the new positions that are being created.

The major deterrent in setting up hospital health science librarianship educational programs is the lack of qualified teachers. Library schools must begin now to work with medical resource libraries to investigate what is to be taught, how it is to be taught, and who is to teach.

## REFERENCES

- <sup>1</sup>James F. Ballard, "Training for Medical Librarians," Bulletin of the Medical Library Association, XV (July, 1925), 30-31.
- <sup>2</sup>Eliot Freidson, The Hospital in Modern Society (New York: Free Press of Glencoe, 1963), p. 13.
- <sup>3</sup>A. R. Dochez, "President's Address," Transactions of the American Clinical and Climatological Association, LIV (1939), 18-26.
- <sup>4</sup>A. Strauss et. al., "The Hospital and Its Negotiated Order," in Freidson, op. cit., pp. 147-69.
- <sup>5</sup>D. N. Kluge, et. al., "The Expanding Emergency Department," Journal of the American Medical Association, CXCI (March 8, 1965), 801-805.
- <sup>6</sup>Cf. Richard M. Magraw, Ferment in Medicine (Philadelphia: Saunders, 1966), pp. 84-103.
- <sup>7</sup>Cf. Directory of Approved Internships and Residencies (Chicago: American Medical Association, 1966), p. 20.  
See also, V. M. Pings, Problems of Providing Access to the Scholarly Record to Post-graduate Medical Students in Metropolitan Detroit, Report No. 27. Wayne State University Medical Library, February, 1967.
- <sup>8</sup>K. B. Babcock, "Library Standards: A Symposium, The Joint Commission on Accreditation of Hospitals," Bulletin of the Medical Library Association LI (1962), 81-83.
- <sup>9</sup>R. H. Geister and H. A. Yast, "A Survey of Current Hospital Library Resources," Hospitals, XXXVIII (June, 1964), 55-57.
- <sup>10</sup>V. M. Pings, Availability of Hospital Health Science Library Service to Wayne County Society Members, Report No. 26. Wayne State University Medical Library, May, 1967. It should be noted that there are approximately another 1800 physicians in metropolitan Detroit who are not members of the county medical society, about 650 of whom are osteopathic physicians.
- <sup>11</sup>Distribution of Physicians, Hospitals, and Hospital Beds in the U.S. (Chicago: American Medical Association, 1967), II. These figures do not include osteopathic physicians and hospitals; over 25% of the nation's osteopathic physicians are located in these four states.
- <sup>12</sup>B. C. Johnson, The Integrated Hospital Library - a Categorical Concept, Paper Delivered at the International Federation of Library Associations, Toronto, August 18, 1967. Italics not in the original.

- 13R. T. Esterquest, "Medical Library Service in the Hospital," Bulletin of the Medical Library Association, LII (January, 1964), 253-61.
- 14Ibid.
- 15Helen Yast, Letter, May 11, 1967. Miss Yast reports that applicants with formal education in librarianship are discouraged from attending the Institute.
- 16a. Bulletin of the Medical Library Association, XLVII (April, 1959), 307.  
b. Ibid., LI (October, 1963), 599-600.
- 17Helen Yast, "'...And gladly teach': The American Hospital Association's Experience in Conducting Institutes on Hospital Librarianship," Bulletin of the Medical Library Association, LII (January, 1964), 81-89.
- 18John Martinson, Vocational Training for Library Technicians (Philadelphia: Institute for the Advancement of Medical Communication, 1965).
- 19Cf. G. L. Annan, "Library Technicians: Need, Training, and Potential," Bulletin of the Medical Library Association, LII (January, 1964), 72-80.

EDUCATIONAL PROGRAMS FOR HOSPITAL HEALTH SCIENCE LIBRARIANS  
by Dr. Vern M. Pings

Points from the Group Discussion

---

1. The hospital librarian works with the same scholarly record as the medical librarian but there is a difference in the quantity of material actually present. The primary difference is one of emphasis rather than one of technique and purpose. The hospital environment also requires a different attitude toward service because of the pressure of time.
2. Hospital health sciences librarianship is in a kind of limbo. We need to train the manpower to operate these libraries and this training may or may not lead to an academic degree.
3. An analogy can be made to the needs filled by the land grant colleges. This movement provided farmers with the opportunity to acquire, through short courses, knowledge about scientific farming with the objective of producing better agriculture. Can a similar approach be developed for the hospital health science librarian?
4. Educational programs must be developed in relation to a multiplicity of forces influencing bio-medical communication at various levels, in a variety of agencies, and with a diversity of users.
5. If library education were to produce hospital health science librarians would they be accepted by the medical community? Would there be enough demand and would there be financial resources to employ these people?
6. Is a systems approach applicable to hospital health science librarianship? Ignorance of systems, and their resulting benefits, perpetuates the isolated library.
7. The economic bases for support of the health science library in the hospital must be identified. Is this the responsibility of the hospitalized population? Is it the responsibility of physicians? Is it a public information service of state government, of the federal government?



EIGHTH SESSION

SYSTEMS CONCEPTS AND LIBRARY EDUCATION

By

Richard H. Orr  
Director, Institute for Advancement of Medical Communication  
Philadelphia, Pennsylvania

## Background of Convictions Regarding Library Education

If anyone wonders how my strong opinions on library education developed, my biographical sketch will not be very informative. In reverse chronology, the historical background of my opinions goes something like this: Recently, I have been involved in a continuing series of discussions concerning the educational objectives and curriculum of a particular library school. During the past year or so, I have been working on a project devoted to developing and testing a large variety of methods that, hopefully, will be useful to those responsible for planning and managing libraries and library systems. For the past several years, I have been reading voraciously the literature of librarianship and attending, more selectively, the meetings of library associations. Earlier, before I finally recognized the key position of libraries and librarians in both today's and tomorrow's information systems, I thought that "documentalists" might have the answers everyone was looking for; and sometime around 1956 or 1957, I joined their camp. As I look back on my formative influences, however, I find that this capsule history omits two important elements--my own educational experiences, and a decade's study of medical education and its problems. I had not realized how much these latter elements had shaped my convictions about library education until I started preparing this paper. Then I saw that I was making analogies, not only between the inadequacies of my education as a physician and those that librarians complain about, but also between the evolutionary development of medical and library education.

### Propositions

Two propositions summarize my opinions--at least those relevant to the topic I was assigned. The first proposition is that, what I will call for lack of better terms, the "systems approach" and the "discipline of cost-benefit evaluation" should pervade all parts of the library school curriculum and could be used to integrate these parts into a whole. The second is that, unless separate schools, or separate curricula, are established specifically for training medical library personnel, any really major improvement in the education of medical librarians depends upon general changes in library education. At the conference there will probably be considerable discussion of the special needs of medical libraries, some of which may be met by personnel whose complete training can be accomplished outside of library schools. However, given that the key personnel for medical libraries will continue to be trained in library schools, and that they will continue to share a basic curriculum with those preparing for other types of libraries, I doubt there will be any serious disagreement with this second proposition. Therefore, the rest of this working paper will be devoted solely to the proposition about the value of the systems approach and the discipline of cost-benefit evaluation in library education.

---

\*Preparation of this paper was supported, in part, by Public Health Service Grant HE-5414.

### Strategy for Developing the Argument

A closely reasoned, definitive development of the argument for this proposition would require a small book, which I have neither the energy nor the ability to write. However, if the proposition has anything like the merit I believe it has, even a very sketchy and tentative exposition should be enough to convey the basic idea to individuals of the type Dr. Lieberman has invited to this conference. This working paper represents such an exposition. My strategy is to stimulate you to start filling in the gaps in my argument and extrapolating from the "bare-bones" treatment I provide in this paper so that, when we meet for discussion, further development of the argument will be a joint effort. You can see that this strategy depends on two assumptions--that the idea has sufficient merit, and that the conferees have sufficient intelligence. If either assumption is invalid, the strategy will fail. Should this happen, each of you will be able to decide, at least to your own satisfaction, which of the two assumptions was the weak one; whereas, I will never be able to pinpoint the real reason for failure.

### Problems of Library Education

It is sometimes difficult for me to distinguish clearly between the problems of libraries, of the library profession, of librarianship, and of library education. Perhaps, as an outsider, I'll be forgiven if I confuse these problems somewhat, especially since there seem to be such a large number and variety. By not attempting to specify any particular problems, I could avoid the risk of making such mistakes; but the chief merit of my proposition is the promise it holds for contributing to solutions for these problems. Therefore, I've elected to try to identify a small sample of problems, without implying that they are necessarily the most important ones. To limit the risk further, I'll confine myself to 4 problems that eminent librarians recognize as important--if I interpret their statements correctly. Dr. Brodman, in her keynote paper for this conference, emphasizes the problem of educating librarians who can adapt rapidly to change--in society, in medicine, and in librarianship itself. I have not yet seen Dr. Asheim's working paper for this conference, but elsewhere<sup>1</sup> he has eloquently called attention to the need for different kinds of educational programs designed to prepare individuals for different levels of library work, and to the need for a new approach to job classification. From his concern with these needs, I conclude that the problem of establishing educational objectives based on a functional analysis of library work is an important one. Dean Jesse Shera, at this year's ALA meeting, stated a problem he thinks is important--the problem posed by current failure to attract "the right kind of people" to librarianship.<sup>2</sup> For the last problem in my not-so random sample, I am unable to cite a specific authority--unless I am mistaken, it has been alluded to by many, but I wasn't able to find a suitable reference quickly. This is the problem caused by lack of an integrating conceptual framework for librarianship.

My tactics will be to run very rapidly through a few examples of how the systems approach and the discipline of cost-benefit evaluation can be applied to things that concern librarians and to indicate, even more cursorily, how these intellectual tools could play a much more central role in library education than they do now. Since I suspect

that many of you are already thinking along these lines, I am hopeful this summary treatment will be enough to at least suggest the promise these tools have for helping to solve the 4 problems I have identified. I am even more optimistic in that I hope you will recognize their potential contributions to solutions for some of the many other problems of library education.

### Systems Approach

I am unhappy about having to use such terms as "system analysis," "systems approach," and "cost-benefit evaluation" to convey the meanings I want. To some librarians these terms still connote purely mechanical or electrical systems--whereas I am thinking primarily about people systems and people-machine systems. Also, these terms smack of engineering or McNamara-type jargon; but I haven't yet found better ones. The word, system, has itself become a catch-all word, like "thingumajig"--a word we use to mean almost anything and everything we want it to mean. We assume that our audience can identify which system we are talking about from the context of our remarks; even worse, in the course of a discussion, we often switch rapidly from one system to another without warning and expect everyone to follow each change. We all seem to have adopted Humpty Dumpty's philosophy that, "when I use a word, it means just what I choose it to mean--neither more nor less." Perhaps better terms will be suggested during the discussion.

The following table illustrates one way that systems of interest to librarians may be categorized by organizational level and suggests analogous categories for biological systems.

<u>Information Systems</u>	<u>Biological Systems</u>
1. "Information Complex"	1. Biome
2. Group of Information Service Facilities	2. Population
3. Information Service Facility (e.g., library)	3. Organism
4. Information Service (e.g., provision of documents)	4. Organ
5. Process	5. Tissue
6. Operation	6. Cell

Since, at least to my way of thinking, the users must be considered an integral part of any system at Levels 1, 2, 3, and 4, one can think of completely mechanized systems only at Levels 5 and 6. An analysis of a system can be concerned primarily with what is done (functional analysis), with who or what does it (component analysis), or with a mixture of both. I will use, as illustrative examples, some of the analyses we have done at different organizational levels. The 7 figures grouped below were selected from



a larger series of diagrams depicting the results of a functional analysis of the total biomedical information complex.\* Here the system (Level 1) includes all formal and informal mechanisms for handling information that the biomedical community generates and uses. These diagrams depict equally well the system serving science in general, and even the system serving society as a whole. You will note that Figures D-1, D-2, D-3, D-4, and D-4A focus on processes performed by libraries. Some of these processes are also carried out by other types of information service facilities, such as abstracting/indexing services. An analysis of this type is very useful for identifying the common features of different types of information service facilities, and for indicating that facilities with names leading one to believe they are different may actually be functionally identical.

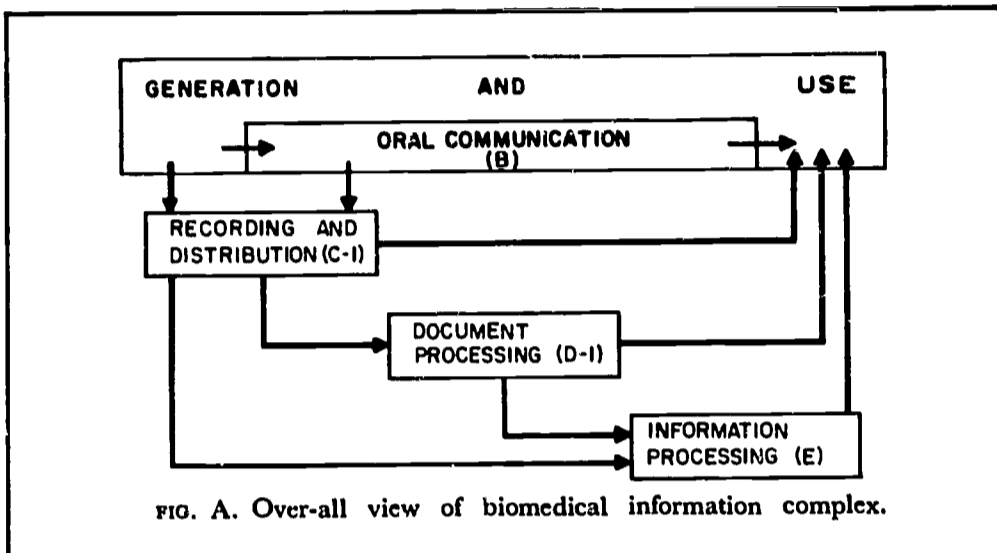

FIG. A. Over-all view of biomedical information complex.

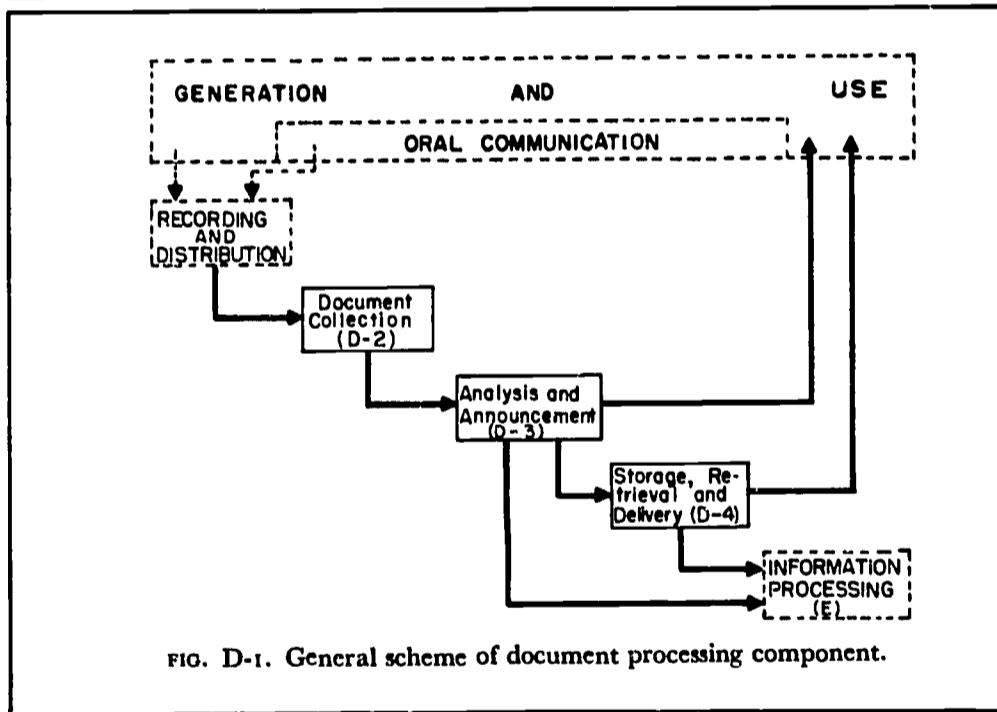

FIG. D-1. General scheme of document processing component.

\*These figures are reproduced from Orr, Richard H., Gregory Abdian, Charles P. Bourne, Edwin B. Coyle, Alice A. Leeds, and Vern M. Pings. The biomedical information complex viewed as a system. *Federation Proceedings*, Vol. 23, No. 5, September-October, Part 1, 1964, pages 1133-1145.

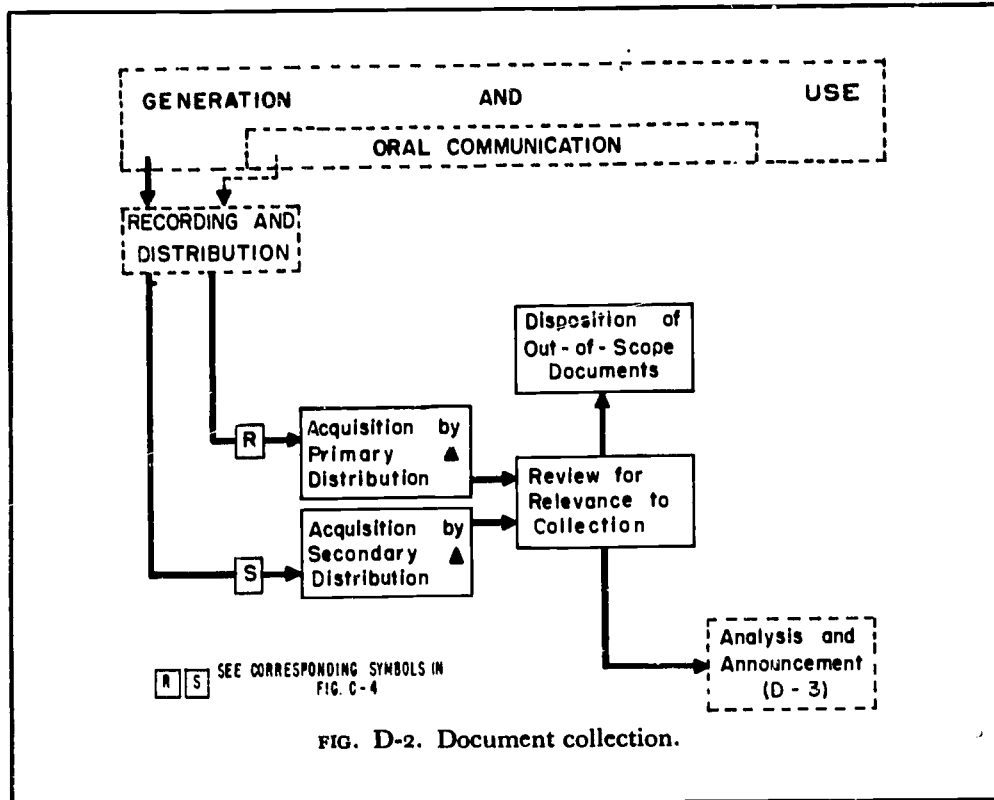

FIG. D-2. Document collection.

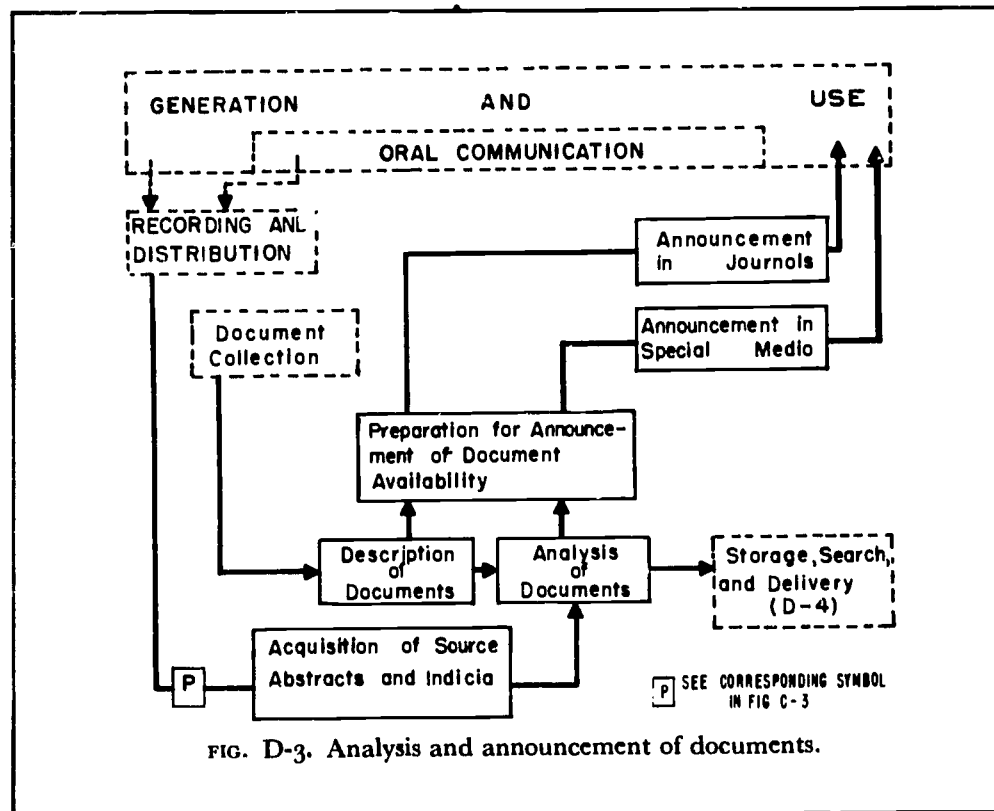

FIG. D-3. Analysis and announcement of documents.

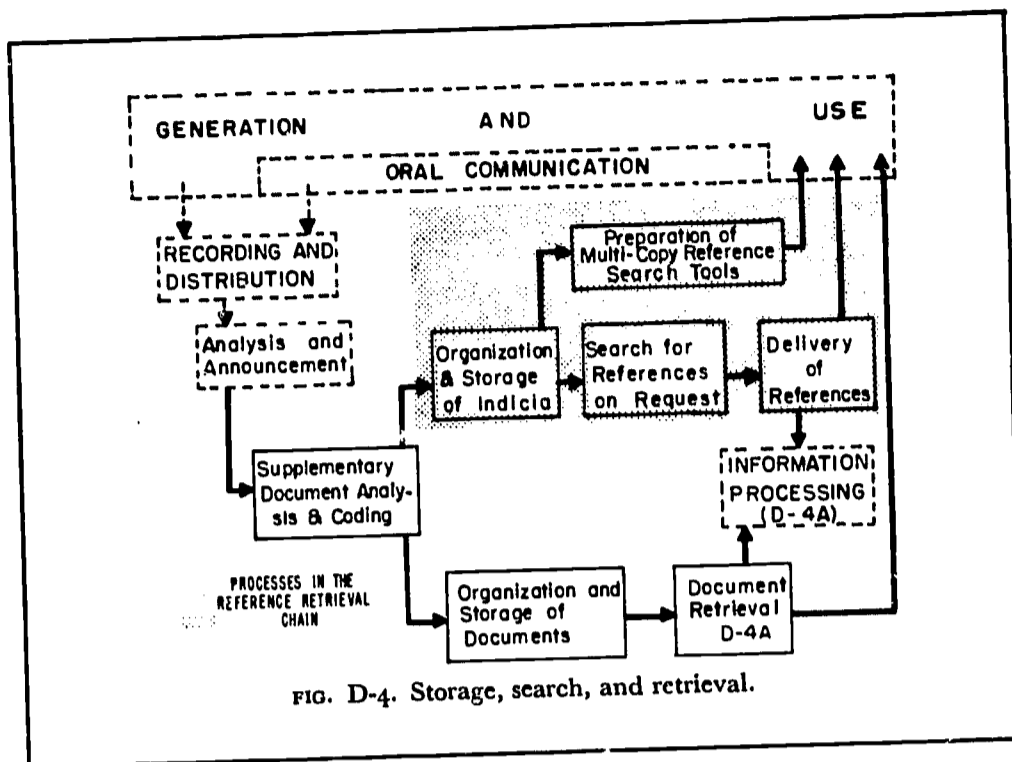

FIG. D-4. Storage, search, and retrieval.

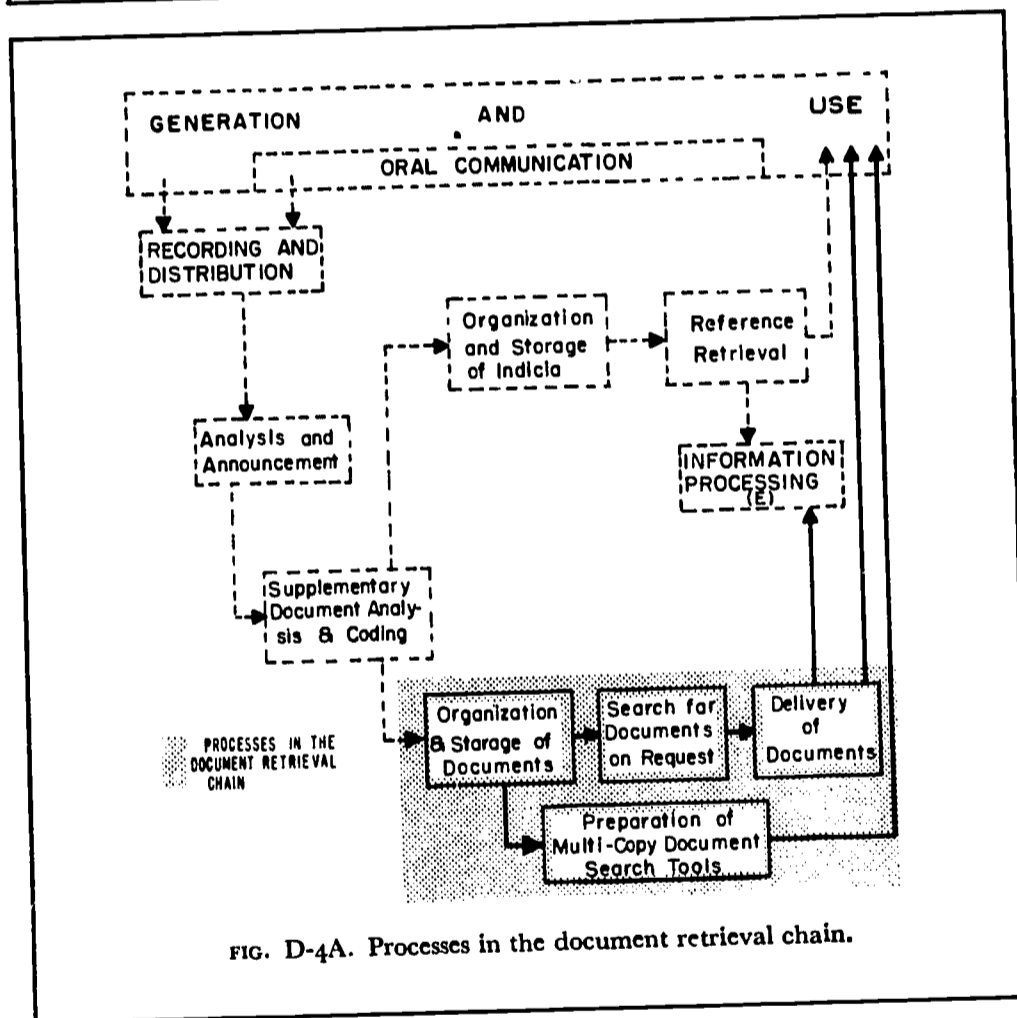

FIG. D-4A. Processes in the document retrieval chain.

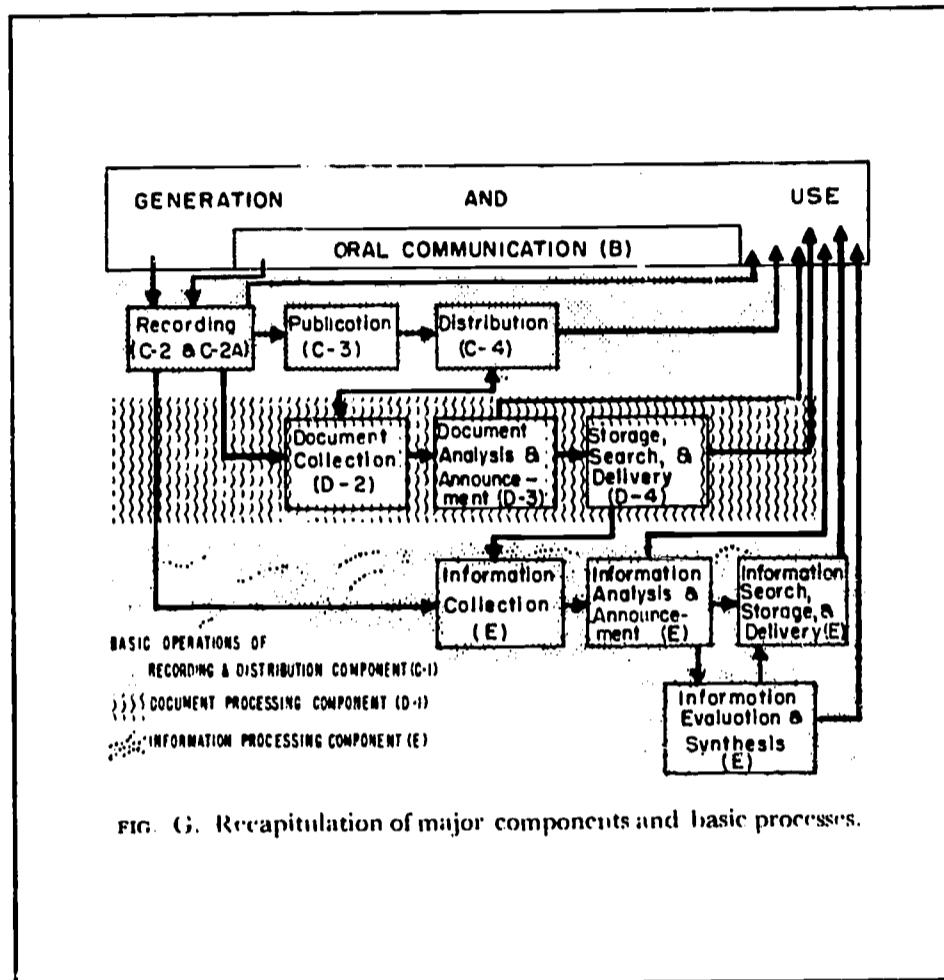
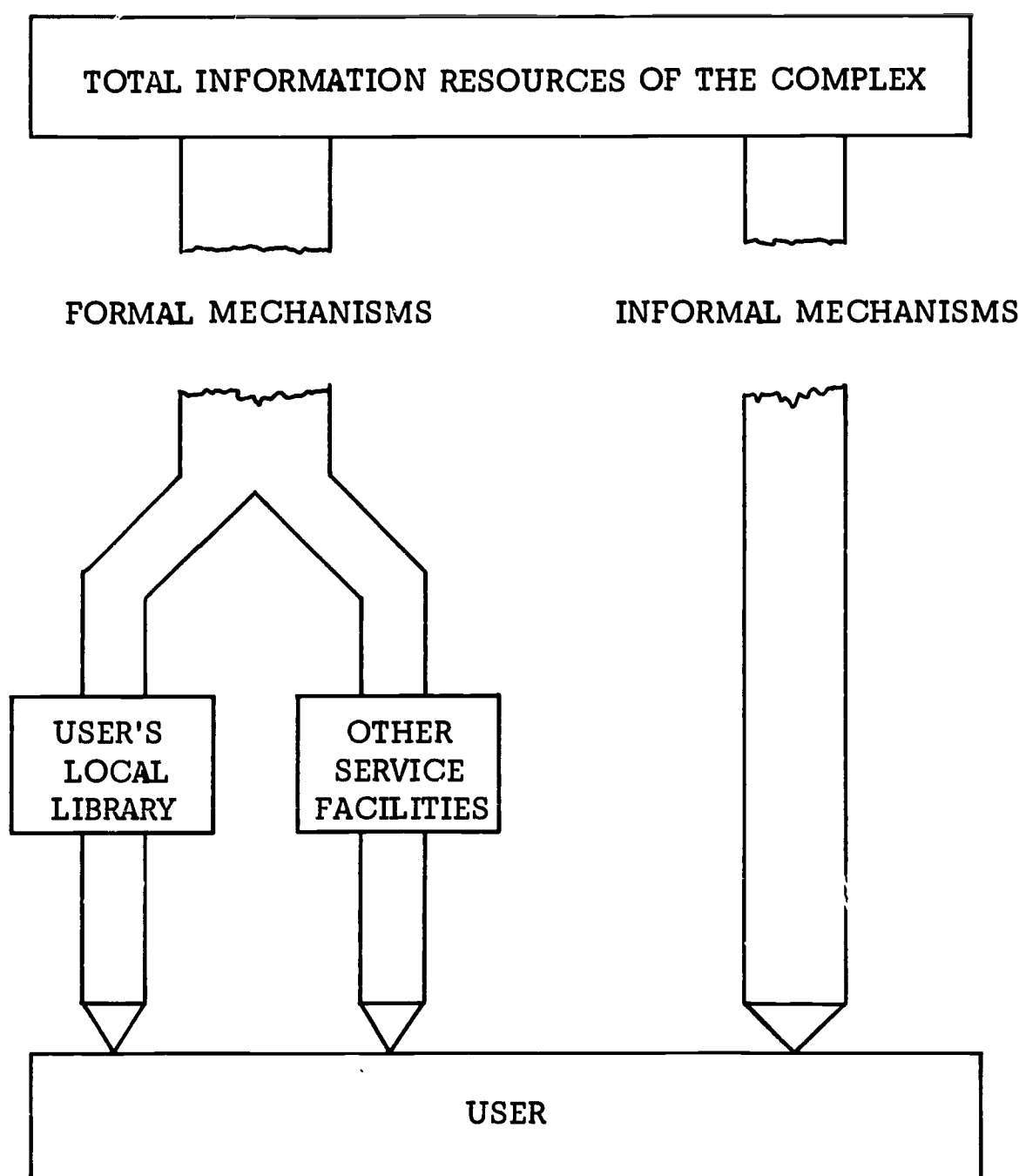

FIG. G. Recapitulation of major components and basic processes.



The following diagram shows the general components of the same complex. Many of the user's needs can be filled by more than one of three channels shown; and this type of analysis brings out the fact that, in filling the total needs of a user (or of a user population), the local library "competes" not only with the host of other information service facilities that are available to him, but also with the great variety of ways users have of getting what they need by informal mechanisms, such as, requesting reprints from authors, asking colleagues, etc. Existence of a state of dynamic competition explains why libraries that are improving one of their services are sometimes suddenly overwhelmed by an unexpected surge of demand--at a certain point in the course of this improvement, the given library's service becomes more attractive to users than a heavily used alternative way of meeting the same need, and the load previously carried by the alternative is suddenly shifted to the library. A full appreciation and understanding of this concept can also help to prevent such occurrences and can be very helpful in planning for improved services.



The next diagram illustrates a Level 2 analysis of the information service facilities in the complex (i.e., the formal mechanisms in the preceding diagram) and also shows the functions they serve. Solid arrows depict the flow of requests and services if the user's own institutional library acts as his "interface" with the world's total resources of information service facilities--as his agent in acquiring from other facilities what he needs, if it cannot meet these needs itself. Many believe such an arrangement has very important advantages over requiring or encouraging the user to deal directly with a large number of different services (broken arrows); and this concept is basic to most of the emerging plans for regional and national services. Unless the education of future librarians succeeds in establishing this concept in their professional philosophy, they will not adapt successfully to the changes that are now occurring and will accelerate as communication links among information service facilities make the dream of effective "networks" a reality. I have just begun to realize how this concept will affect the whole value system of librarianship.

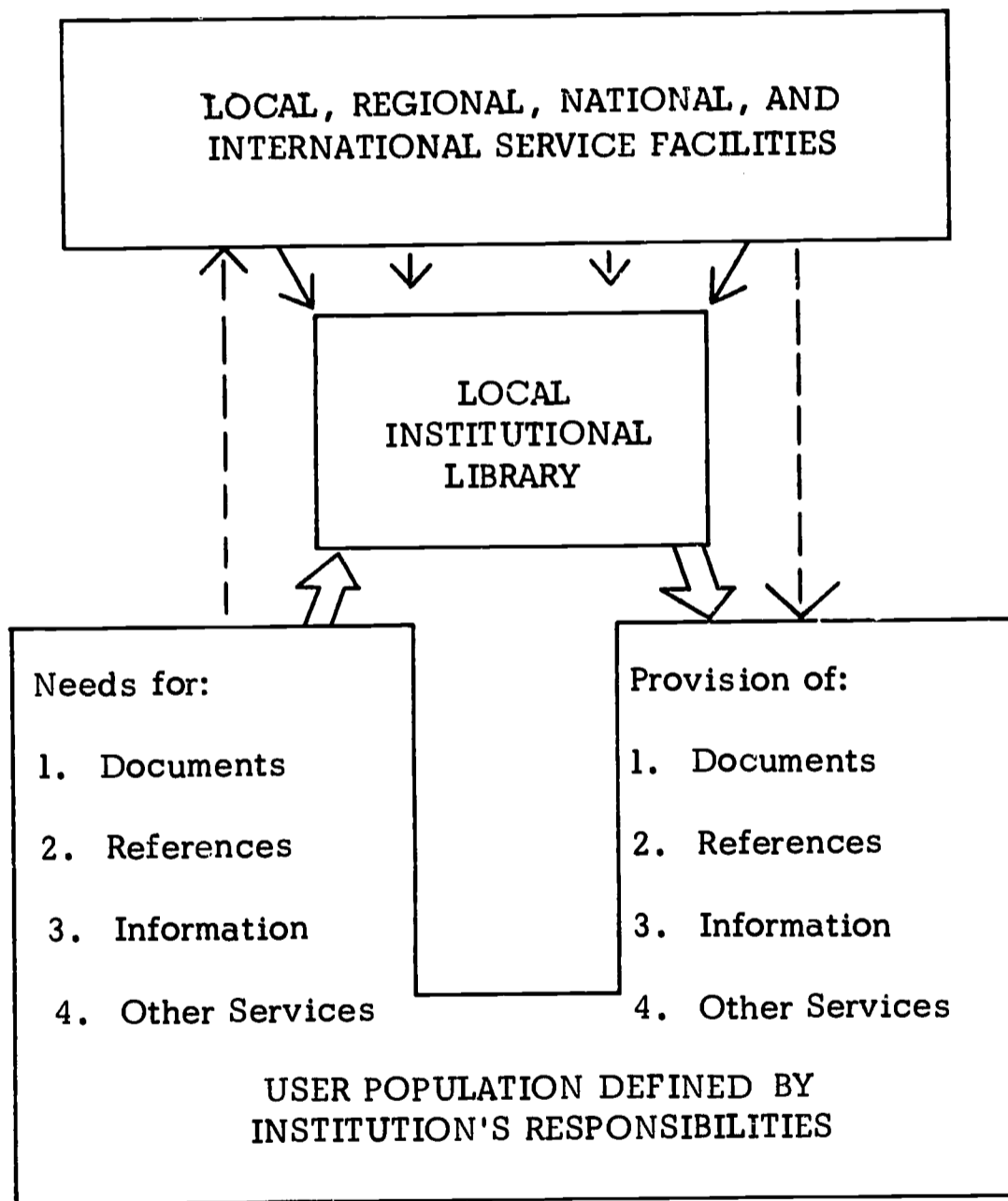

At the same level (Level 2), the component analysis depicted in the following diagram indicates some of the different ways regional systems can operate with varying degrees of centralization. At present, there are de facto regional systems approximating each of the four types of organization shown. The wide range of alternative approaches to be considered in regional planning becomes obvious when presented in this way.

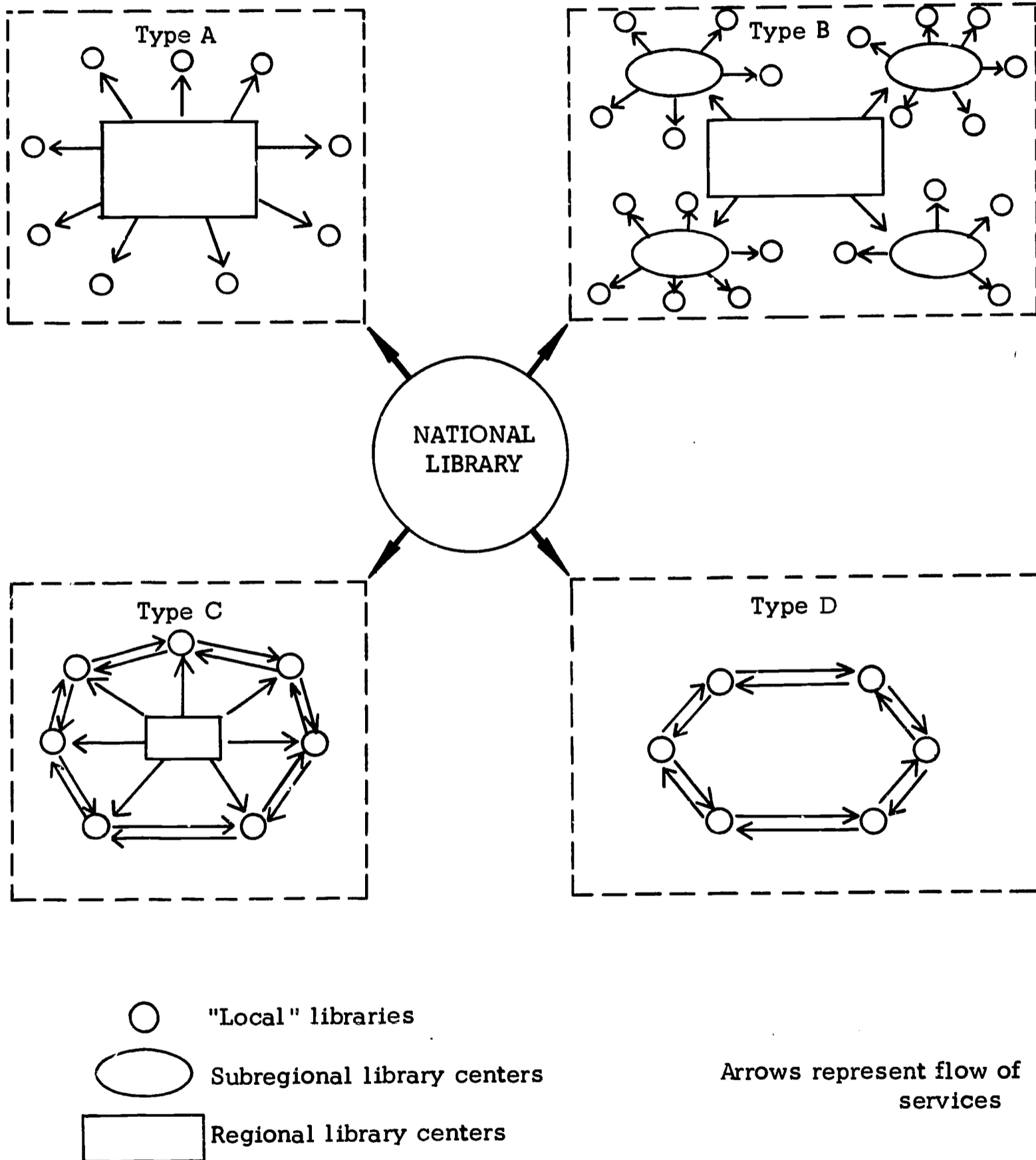

Below is another example of an analysis at Level 2\* depicting finer detail and focusing on the processes entailed in interlibrary loans. The diagram\* emphasizes the functional equivalence of borrowing originals and of securing facsimile copies in lieu of originals; it shows concisely and simply both the similarities and differences in the basic processes required for 2 alternative ways of meeting the same need. Such an analysis enables a student to see quickly that the over-all time between when the user requests a document and when it becomes available to him is the sum of 5 variables--the borrowing library's processing time for preparing the request + transit time of request + loaning library's processing time for the request and for the loan to be sent + transit time of loan + borrowing library's processing time in readying the loan for use and notifying the user of its availability. It provides an excellent basis for systematic consideration of alternative ways to shorten the over-all time. Students trained in this type of analysis should have no difficulty in determining what practical differences in elapsed time would result from merely substituting a teletype request for a mailed request, or from going to telefacsimile transmission of loan material, if the other variables remain constant. They will rapidly see that, for most I-L loan transactions today, reducing either or both transit times by "instantaneous" transmission will result in dramatic improvement only when the borrowing and loaning libraries' processing times have been markedly reduced from what is typical today.

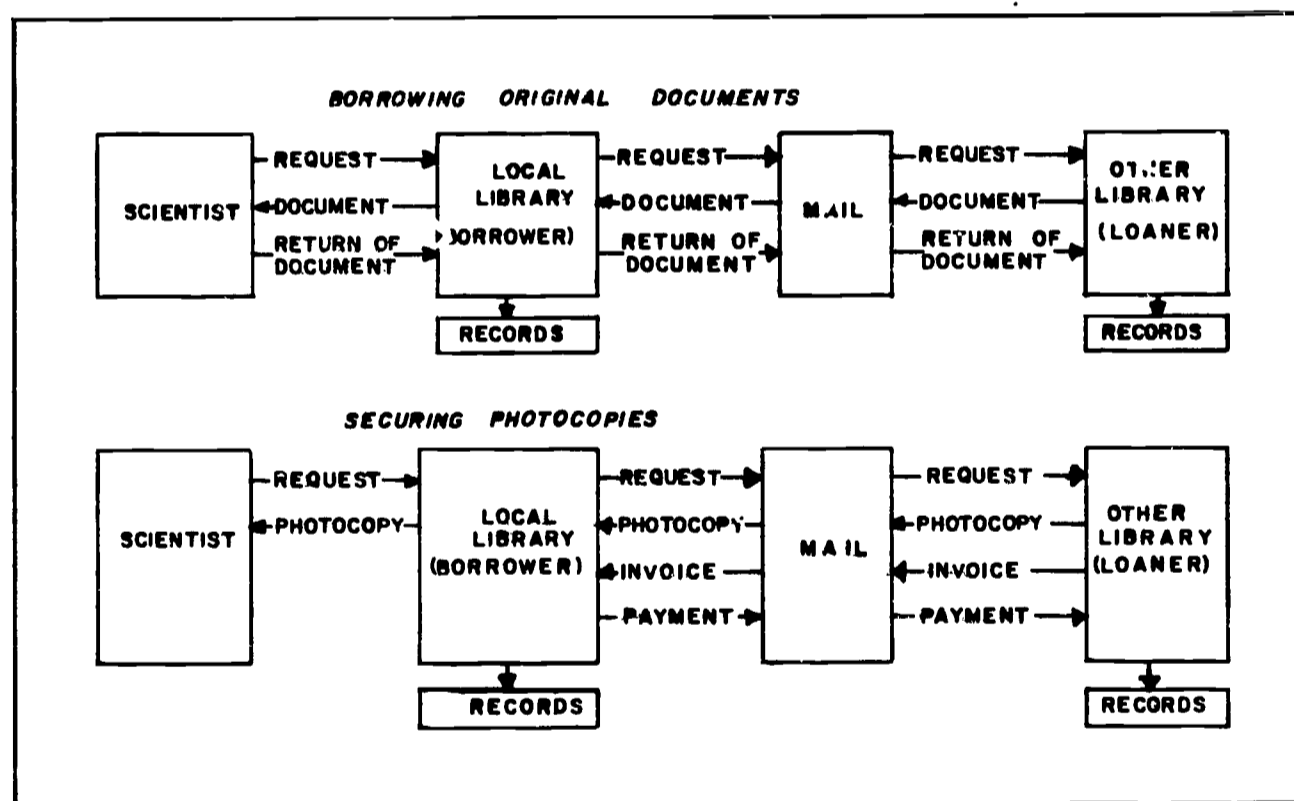

\*This figure is reproduced from Orr, Richard H. and Vern M. Pings, Document retrieval: the national biomedical library system and interlibrary loans. Federation Proceedings, Vol. 23, No. 5, Sept.-October, Part I, 1964, pp. 1153-1163.



I could proceed to illustrate analyses of progressively lower-level systems, for example, by opening up the boxes representing libraries and looking inside at what actually goes on in processing interlibrary loans. However, intralibrary flow charts, such as those used for studies aimed at automating library routines, are familiar to all of you; therefore, it seems unnecessary to show examples of analysis at Levels 3, 4, and 5.

### The Discipline of Cost-Benefit Evaluation

I will treat the discipline of cost-benefit evaluation even more sketchily than I did the systems approach. Almost as soon as librarians began to receive salaries, they probably started using cost analyses, at least of a primitive type, to prove how efficient they were. Quantitative measures of the effectiveness (benefit) of library services, processes, and operations do not seem to be as ancient; and until modern times, they were very crude. Cost-benefit evaluation, which combines both types of assessment, began to be used relatively recently. Its goal is to achieve either maximal effectiveness for a given cost, or minimal cost for a given effectiveness. In its simplest applications, and in systems at Levels 5 and 6, it has been employed more-or-less systematically by some librarians during the last century. However, as of today, only a start has been made in applying this discipline to higher-level systems--probably because, at these levels, effectiveness has been difficult to measure quantitatively. Measurement of costs can also be complex when severe personnel shortages exist, since personnel time cannot be realistically translated into dollar equivalents under such conditions. Also, in analyzing systems at Level 4 and above, interesting philosophical questions arise about what costs should be considered--costs to libraries, costs to user populations (primarily, their time), or costs to society (loss of productivity).

The general procedure I am talking about may be schematized, in an overly simplified fashion, as shown on the following page. In cases where reasonably accurate estimates of effectiveness and cost can be made, steps 4 through 6 can, of course, be carried out symbolically (simulated) to evaluate alternative ways of meeting the system objectives. When students understand that any system being evaluated may be part of some higher-level system they will appreciate the potential hazard of using this powerful tool--the risk of "optimizing" a given system only to find later one has been "penny wise but pound foolish" in that a higher-level system has been affected adversely.

Work on the on-going project I mentioned earlier in relating the background of my opinions has resulted in some practical, reliable methods for measuring quantitatively the effectiveness of at least a few of the basic services libraries provide; and a start has been made on similar measures for regional library systems and on using the kind of data these methods provide for cost-benefit evaluation. If anyone is interested, I'll be more specific during the discussion. I am convinced that, within a few years, it will be possible and practical to measure objectively most of the benefits libraries can provide, and to use these methods routinely in almost all types of libraries and for systems at all levels.

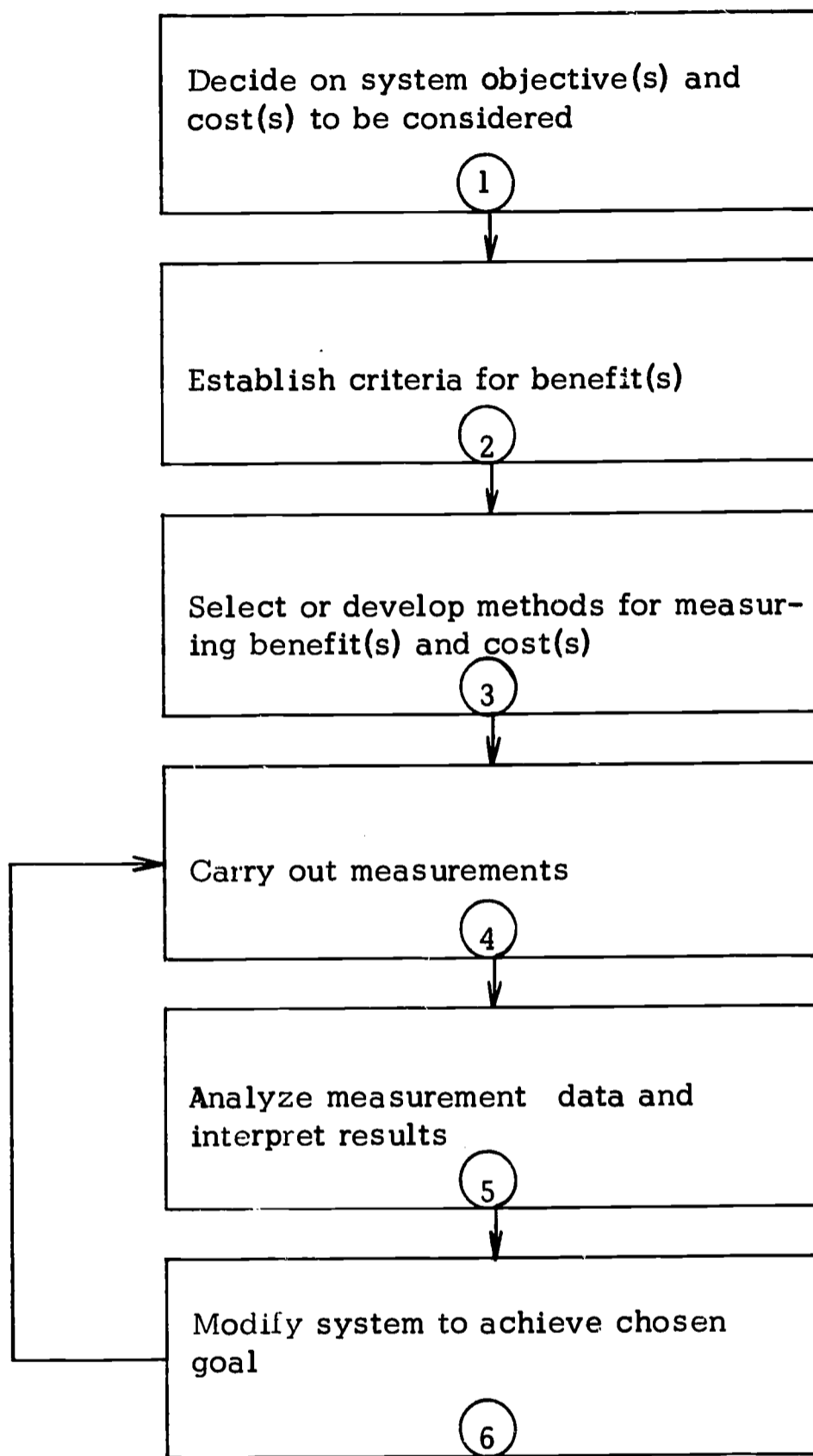

Student librarians will have to be well prepared, intellectually, if these methods, and the rigorous kinds of evaluation the resulting data will make possible, are to be comfortable tools for their own use, rather than threatening procedures applied by others-- and this holds for all professional librarians, not simply the managerial types.

## Potential for Solving Problems of Library Education

Since I am assuming that some of you may have had relatively little exposure to systems concepts, whereas I know that some are highly sophisticated in using these tools, in my effort to be certain that what I mean by the systems approach and the discipline of cost-benefit evaluation is clear, I have tried to steer a middle course between being confusingly sketchy and being insultingly didactic. I'm sure I failed and hit both rocks--not once, but several times. Along the way, I threw out a few more-or-less cryptic hints about what I am proposing, and how the tools I was describing might help to solve the library education problems I selected. Now, I'll make another attempt at giving no more, and no less, explication than is called for--and this one is also sure to fail.

Some of you have undoubtedly thought, "Doesn't he know that some library schools already have courses in systems analysis, etc., and that this hasn't done much toward solving the problems?" But I am not advocating tacking any such courses onto the standard curriculum. What I propose is much more radical--it is incorporating these concepts into all courses and reorganizing the entire curriculum with systems concepts as the integrating framework. Medical education is currently in the process of doing much the same thing. In some medical schools, the changes were made relatively quickly, in others it is occurring more slowly. If the analogy is not obvious, it can be developed in the discussion. Exactly how this proposal could be implemented in library schools, I am neither qualified nor prepared to say. But I have a strong feeling the changes can, and will, occur more rapidly in library education than they have in medicine--there are fewer sources of resistance and stronger incentives.

Suppose library education were radically changed along these lines, how would this help to solve the problems identified? As I stated initially, I am not going to attempt a definitive exposition of the argument; however, I will try to suggest a general outline. First, students who have been trained to use these tools, and to approach practical problems concentrating on ends, rather than means, should be able to adapt rapidly to changes in technology, in librarianship, in medicine, and in society itself--ends change much more slowly than means. Second, these tools are now being used successfully in other fields to establish educational objectives based on functional analysis of what students are expected to do after graduation--why not in library education? Third, an educational program that consistently emphasizes rigorous analysis and quantification will attract a new type of students to librarianship--I think they will be "the right kind of people," but we should ask Dean Shera, since the phrase is his. Last, the systems approach would seem to offer a unifying conceptual framework into which can fit all the bits and pieces of knowledge librarianship has accumulated--this should make it easier for educators to teach, and for students to learn.

I hope I have succeeded in stimulating you to think about how these tools might be used in helping to solve the problems of library education. If they do have real promise, you will see many applications I have not thought of; and in the course of formal and informal discussion at the conference, we can begin to develop a sound argument for the proposition.

## REFERENCES

- <sup>1</sup>Lester Asheim, "Manpower: A Call to Action," Library Journal, XCII (May 1, 1967), 1795-98.
- <sup>2</sup>Jesse H. Shera, as reported in Library of Congress Information Bulletin, (July 13, 1967), Appendix 2, p. 453.



+

## INTRODUCTION AND INTEGRATION OF THE CONCEPTS OF SYSTEMS ANALYSIS

by Dr. Richard W. Orr

### Points from the Group Discussion

---

1. What is the conceptual framework of health sciences librarianship? What is the conceptual framework of librarianship? Philosophy and a theoretical body of knowledge provide the foundation for teaching and enable the student to work within a framework which integrates his thought.
2. The systems approach is useful in curriculum development. Library education should utilize systems analysis in evaluating present goals, functions, results and future directions.
3. The library school, as a part of the university, should articulate its curriculum with other colleges, departments, schools, etc. A creative dialogue should also be maintained between the library school and practicing librarians.
4. Library education has always stressed service as the ultimate goal. Service is an integrating concept for all curriculum planning.
5. Health sciences libraries are called upon to provide information to facilitate communication in support of research, teaching and patient care. More knowledge of the functions of the health sciences community would enable librarians to specify what kinds of information and services ought to be provided. Functional analysis of the environment is essential to the planning of an educational program.
6. In addition to professional education, the health sciences librarian should have the capacity to raise relevant questions about his profession and its relationship to the whole field of biomedicine.

NINTH SESSION

INSTRUCTION IN THE MODERN TECHNIQUES OF BIOMEDICAL COMMUNICATION

By

Ralph T. Esterquest  
Librarian, The Frances A. Countway Library of Medicine  
Boston, Massachusetts

Thanks to an abundance of federal funds and foundation support in recent years, great strides have been made in medical research and discovery. The number of individuals working in medical laboratories and seeking to eradicate one disease or another is enormous. Never before has the human race had so much attention given to its ailments and to the scientific basis for their alleviation. All of this activity has resulted in an ocean of published materials, to the mobilizing of which librarians are fortunately giving concentrated attention.

Unfortunately, there is another and transcending problem, not so widely understood-- a problem whose solution will require the collective wisdom of the entire biomedical community. This is the problem of transmitting effectively the newly-won medical knowledge to the practicing physician when he needs it, so that yesterday's laboratory discoveries can be brought to bear at the point where the doctor is treating his sick patient today. Presumably the national effort in health-related research is directed to the cure or relief of man's illnesses. But many of the tangible results of research are tragically slow in reaching that point which is clearly the ultimate target.

Recognizing the problems that science librarians face in handling the proliferating literature, the better library schools are giving attention today to the "newer techniques" and the "new technology." They recognize that tomorrow's science librarian will need to know how to use electronic equipment and the approach of systems design to organize the research literature for effective use, and efforts are being made to provide a place in the curriculum for an exposure to these subjects. Unfortunately, the approach seems to be limited in two ways: First, the focus of attention is on the research literature (e.g., journal articles, technical reports); second, the audience for whom the effort is primarily made is the research community. MEDLARS, current awareness services, the NINDB information centers, and similar new developments are oriented to delivering bibliographic information, usually about journal articles, to research investigators. The practicing physician is welcome to use these services, of course, but the product that is put into his hands is not designed with his special needs in mind. What he is apt to find more useful than a list of citations is a distillation of the latest information on treatment or diagnosis. He needs a product that synthesizes in a practical, readily-understood form the end result of the research work that bears on his problem of the moment.

This lack is not one that has just been discovered. Publishers of loose-leaf services recognized it and attempted to provide an easy-to-use product. Audio-Digest tapes represent another product which sells itself on the strength of filling a recognized need.

What is really needed is a concerted effort on the part of the biomedical community to discover and develop the techniques of science writing, the use of audio-visual aids, and other devices and skills that can be brought to bear on the broad aspects of biomedical communication.

At the University of Nebraska Medical School a special Communications Division is known for its outstanding work in the use of television in medical education at various

levels. At the same institution courses are given in medical writing. At the Public Health Service Audiovisual Facility in Atlanta, special skills have been developed for producing and using films and other A-V aids in biomedical communication.<sup>1</sup> Experimentation with computer-assisted instruction is being carried on in a number of places. The alert medical librarian finds out about these developments. If the library school student has a voracious reading appetite, he too finds out about them. A library school today that intends to fully train medical librarians must give more than passing attention to the special techniques as well as to the broad concepts of biomedical communication.

At this point, one might ask why the library and the library school need concern themselves with this problem. Perhaps such special techniques as the use of audio-visual aids might just as well be left to the experts in these fields. To follow this course would be to abdicate a role that is central to librarianship. It used to be said that librarianship had to do with bringing the right book and the right reader together. In the context of the medical library, this can be rephrased to say that the librarian is there to bring the right information in the right form to the right person at the right time.

To perform this function, the properly-trained librarian should understand the problem, recognize the potential of the special aids, and--with his special knowledge--command the respect of his dean and his faculty. He should be the one they turn to as the expert on the scene--not the expert on how to repair and rewind movie film, but the expert who appreciates the potential of film, and of television, and of science writing in the teaching and learning process. The fully-trained biomedical librarian should be the campus or community authority on biomedical communication, whether this communication takes place via the book and journal or via one of the non-book forms.

A course offering in the library school might cover such subjects as: the psychology of the learning process; methods of evaluating the effectiveness of teaching techniques; theories of communication; the technology of communication equipment; communication tools: the spoken word, radio, television, motion pictures, slides, filmstrips; biomedical writing and editing; computer-assisted instruction. Such a course would draw upon skills and personnel in other units of the university, since it cannot be expected that a single teacher would possess the broad knowledge required to be an expert in all the fields indicated. The content and the goals of such a course, however, ought to be controlled by the library school.

Medical librarians with background knowledge in the subject areas suggested above would have an important impact in their communities in terms of their possible contribution to improved medical teaching. Hopefully, their contribution would ultimately extend to the whole area of biomedical communication, especially as it bears on the need to bring newly-won medical knowledge to the practicing physician. A few librarians, well trained in the broad aspects of biomedical communication, could form the nucleus that would train others.



As an extension of the above paper, after consultation with Ralph Esterquest, Irving Lieberman offered copies of his recently prepared paper: "The Use of Non-Print Media in Library School Instruction" presented at the University of Illinois International Conference on Librarianship. Pertinent parts of that paper which will appear in Library Education: An International Survey (edited by Larry E. Bone) in 1968, are included below.

In 1963 the Association for Higher Education joined the Division of Audiovisual Instructional Service of the National Education Association to produce a yearbook<sup>2</sup> which pointed up the contributions of the new media. This volume contained a landmark survey of the character of the uses being made of the new media by colleges and universities in the United States in 1961. As a follow-up to this report there is currently under way a new study, the Higher Education Media Study (HEMS), conducted by the same leadership. This study was made possible by a contract with the Bureau of Higher Education of the U.S. Office of Education through the joint efforts of a staff cooperating with the Association for Higher Education and the Department of Audiovisual Instruction of the National Education Association.

The purposes of this project are:

(1) To inventory some of the current (1967) instructional uses of new media of communication in college and university teaching throughout the United States. This has been done by the recent issuance of the Media Activity Inventory-Directory<sup>3</sup> which lists some 650 institutions of higher learning in which current applications of many different kinds of new media applications are being made.

(2) To provide critical descriptions of the varieties of such utilization, their accomplishments, and their problems. During the period between October, 1966, and January, 1967, each person whose name appears in the Directory was invited to submit a brief article (of a thousand words or less) describing the nature, scope, and outcomes of each innovated use cited. These articles will be used as the principal content of a new volume, New Media in Higher Education-II to be published in 1968.

(3) The final aspect of the HEMS study is to assess current media applications in higher education by means of personal visits to approximately sixty colleges and universities.

#### Laws of New Media

In combining the information and impressions gathered through the re-survey of 1963 respondents with those of the in-person visits to approximately sixty colleges and universities and the returns from the mail questionnaire, several generalizations about college and university uses of new media appeared to be justified. Perhaps these generalizations may be referred to as "laws of new media":

The first and most important of these laws might be called "the law of critical mass." It recognizes that no permanent and lasting effect on improving instruction by use of new media will occur until there is a substantial institutional commitment to this purpose. That commitment includes at least 4 elements: (1) administrative involvement expressed in financial support and in recognition of faculty participation, by means both of released time and of promotional policies; (2) adequate capital investment both in space and equipment; (3) technical staff to assist instructors in development of materials and in operation of technical equipment, with leadership of faculty status and with enough workers to complete requested work within a minimum time; and (4) faculty interest in improving the quality of instruction. If any of these factors is absent in any effort to introduce the new media innovation, it is highly unlikely that it will achieve any widespread and lasting influence on the quality of instruction in an institution.

A second and gratifying series of observations may be summarized in a "law of primacy," a descriptive as well as a normative statement. This law states that the primary purpose of the concern of higher education with new kinds of communication technology is the improvement of instruction. At one time, it was fashionable to promote the use of equipment because it would help to combat rising costs or permit larger numbers of students to be accommodated in existing facilities. On at least one or two of the campuses, it seemed to the observers that television or computers were being used primarily because they were fascinating equipment, and "because they were there." This condition seems to be definitely exceptional. The law of the primacy of instructional improvement is a clear deduction from the preponderant evidence. The primary emphasis of workers in the use of new media is on the improvement of instruction and the restoration of the personal element in the instructor-student relationship, rather than in effecting economies, in adapting to increased enrollments, or simply in extending the image of the instructor either to more classrooms or to more times of the day. While such ends were not ignored in any of the institutions studied, no institution claimed them as the primary objective of its experimentation.

A third law may be expressed as a new "law of parsimony"--that except during early periods of research and experimentation needed to establish the potential of a technological innovation, simple and inexpensive techniques and equipment should be preferred to expensive and complicated systems, whenever they are equally effective in attaining instructional goals. This principle is suggested by numbers of experimental reports that find "no significant difference" in favor of the innovative practice. If it is no better than conventional practice, there is little justification for introducing a more elaborate practice to do the same old things. It is still true, of course, that old purposes and old practices may be outmoded, and that innovations might have exceptional value in encouraging

instructors to analyze and to improve their purposes, their practices, and their results with students. In actual practice, this principle would imply that it is uneconomical to use videotape to achieve goals that are dependent solely on sound; if pictures do not add to learning in a language drill, for example, it will be better to use audio tape rather than videotape. If a programmed book with printed pictures can effectively present factual material in science, it is not justifiable to use computer-aided programming, with its costs of computer time and individual terminals supplemented by slides and sound tapes. While experimental uses of such innovations may be necessary so that we may learn whether or not they are more effective than simpler practices, unless there is clear evidence of superior motivation or learning opportunity the simpler practice should prevail.

In summary, exciting breakthroughs toward improved instruction are opened by the waves of experimentation that are inundating campuses of all sorts in all parts of the nation. The sea walls that resist these waves, as always, seem to be composed of equal parts of inertia and poverty, but these are being eroded by the increasing force of successful examples. The future for anyone who believes that new media can encourage better teaching is bright. One caution only: The new media possess no magic. They must be directed by humans to human ends. It is a perversion of their promise to use them only to facilitate outmoded purposes. The key to better teaching, now as ever, rests in the will of the teacher.<sup>4</sup>

### Instructional Status of New Media

The remainder of the Higher Education Media Study consists of specific comments on the instructional status of several varieties of new media as a result of the judgment and insights of the HEMS staff. Each of the descriptive sections concludes with a listing of institutions with brief annotations which describe current practice. These descriptions will make up the body of the report (to be entitled New Media In Higher Education-II) to be published by the National Education Association, Washington, D.C. I have paraphrased below each section on the new media to be included in the forthcoming report.

Instructional Television. When educators first thought of using television in instruction, they were often concerned with its special contributions in solving problems stemming from rising student enrollments and a relatively static supply of new doctoral degree holders, many of whom were being enticed into government and industrial service instead of going into college teaching. Under such circumstances television was often seen primarily as a means of multiplying the professor's audience. Some educators also mentioned a special potentiality of the medium for multiplying the effectiveness of specially able professors under arrangements permitting them to teach hundreds or thousands at one time while other less distinguished professors served as discussion leaders with smaller groups in various remote locations.



The present pressing problem is still that of developing course materials that are worth televising, rather than in planning new and more complicated physical installations. In addition to the colleges that are now using closed-circuit television, videotape recorders, inter-institutional broadcasting, and open-circuit instruction for credit, there are fully as many institutions proceeding with plans to introduce one or more of these uses as rapidly as funds and construction of facilities will permit.

Here are some of the uses of television: (1) Live presentation in a large auditorium. There is the additional option of sending the lecture live to any convenient number of remote receivers, or of taping it for showings at several times and in any number of classrooms. Also, by means of tape, the professor may use television as his own stand-in when he himself must be absent from class, or he may use it as a "re-run" opportunity for students who miss or wish to hear again an earlier presentation. (2) In a large classroom equipped with monitors, or even with monitors in remote classrooms, it is possible to magnify realia or to broadcast microscopic demonstrations so that large numbers of students may view the single visual. (3) The simple microwave transmission of televised signals to receivers at other locations, such as those in a system of colleges where it is either not possible or not economically feasible to staff a given course, or where the specific contribution of some noted lecturer-demonstrator is desired. (4) Some of the most interesting uses of television are those enabling a professor to present and the student to observe events that would be otherwise inaccessible or unobservable, or where the presence of observers would introduce distracting or contaminative elements into the event under study. (5) A self-contained classroom television system--camera, videotape recorder, and monitor--offers exciting possibilities for teaching any sort of skills. As an example, in such diverse fields as student-teaching, storytelling, or in golf, a practice session allows the learner to see, to criticize, to repeat, and to improve his own performance. (6) Open-circuit television courses for college credit are a reality; students have completed work for diplomas by means of broadcast courses.

There is no longer a question of the efficacy of television in extending and in improving instruction in higher education. In every situation where it has been tried and carefully evaluated, the results show that it permits learning that is equal to and frequently superior to that achieved under traditional classroom practices. In addition, it does make possible several kinds of learning that were most difficult or impossible to provide before its introduction to the educational armory. It remains to be seen whether higher education, under all of the pressures of increasing enrollments and expanding fields of knowledge, will be able to rise to the challenge of learning to cultivate the rewards of televised instruction.

Films. The motion picture was one of the first "new media" to be used in instruction. The 16mm. silent film has had a forty-year history of utilization in classrooms in this country. Sound and color films became available for teaching almost as soon as they were introduced into theaters. Films still make important contributions to instruction, and several institutions of higher education are actively engaged in film experimentation.



The teaching film itself has several advantages. It is durable; it is available in a great range of titles and subjects; it may be rented (at very low cost), or purchased.

There are also disadvantages to film use, as compared to other more recently developed media that are used in the classroom. A film cannot be corrected or brought up to date as rapidly and as simply as the videotape. Thus the permanence can be a disadvantage, if it results in the class presentation of outdated procedures or concepts. When films are rented from off-campus agencies, there is a constant problem of scheduling--their inavailability on appropriate dates--so much so that instructors may be forgiven for abandoning their use unless the prints are owned and stored on campus. In addition, the sheer physical labor of assembling the film, the projector, and the screen, and setting up the equipment can be discouraging to any instructor who must care for all these details himself.

A very useful innovation in film usage has direct application to independent study. This is the 8mm. cartridge-contained "single-concept" film loop. In this form, each film may last only five to ten minutes; it can be checked out from the laboratory stockroom, or from the library, inserted by the student into the projector in a near-by carrel, and viewed as often as necessary. Interest in 8mm. color films generated by the convenience and economy of 8mm. cartridge projection is now receiving new impetus. Announcements by several manufacturers of a new 8mm. "Super 8" format which provides superior picture quality coupled with either magnetic or optical sound track systems, is one basis for this new interest. Faculty members who are using or producing films for instructional use uniformly say that the values of both 16mm. and 8 mm. films have not yet been fully realized, even after forty years; that they still can serve some instructional functions more economically and conveniently than other newer media; and that new uses and combinations of uses of film with other new media remain to be discovered.

Listening Laboratories and Audio Tapes. The listening laboratory is perhaps the most successful and widely used of the many new media now available to higher education. More respondents for the HEMS inventory reported activity in television and in computer-assisted instruction; but our instructions asked for innovative uses, and several of the respondents mentioned that they were using listening laboratories "only in the conventional ways." It seems reasonable to estimate that a majority of colleges have at least a minimal language listening facility for instructional use.

The simplicity and convenience of using, reproducing, or duplicating audio tapes make them ideal elements for various self-instructional programs such as language and music study, language drills, random access to banks of master tapes, combining instructional use of tapes with other media such as slides and printed programmed learning units in various forms of computer-assisted instruction.

A more recent adaptation of the listening laboratory is the dial-access system. Under this arrangement, the same types of recording facilities are used; if class instruction in language is included in the functions of the laboratory, at least some of the carrels must be grouped in a single room, and controlled from the teacher's console in much

the same way as in the conventional language laboratory. However, the dial-access facility emphasizes individual study. Dial-access has also made it possible to bring much instruction directly into the living quarters of students.

Perhaps the major problem, here as in other uses of new media, is the unwillingness of faculty members to prepare adequate materials. It is possible that the major advantage of new media is the fact that they enable the professor to see and hear himself, and to be seen and heard by his colleagues, with the consequent motivation for improved performance.

Programmed Instruction. Programmed instruction is a technique of self-instruction that presents instructional material in small segments, followed by a task that permits the student to demonstrate his comprehension or skill. If he performs the task correctly, he is presented with another sequence of learning-response-judgment; if he makes an error, he must either restudy the same material or "branch" to additional instruction before being allowed to proceed with further instruction. The reinforcement effect of immediate knowledge of success or failure, in such cases, is believed to be a powerful stimulus of learning.

Programmed learning may be presented in printed form, in simple or quite complicated teaching machines, by several uses of tapes, or by computers. All of these modes are used in higher education. The crucial problem of programmed instruction is that of constructing the programs themselves. The construction of a useful program for college instruction requires not only deep scholarship on the part of the author, but a willingness to analyze the desired behavioral outcomes of instruction in the subject, to state them in hundreds of quite small increments of learning, to foresee the various misconceptions that students might form at each step, to provide reteaching (branching) at each of these points, and to commit the entire program to the appropriate format (printed book, teaching machine, computer). It is evident that programmed learning is a supplement, not a substitute, for the teacher in a person-to-person relationship with the student.

Self-Instruction. The category of "self-instruction" inevitably overlaps several of the other categories of new media discussed in this report. Yet there is a kind of use that has distinct characteristics that are worthy of separate mention, apart from the listening laboratories, dial access carrels, programs, and computer terminals. The self-instructional laboratory provides the space and the materials necessary for each student to learn at his own rate the concepts and information or skills for a given course. A distinguishing element of the "self-instructional" category is that the student ordinarily (but not always) attends self-study sessions of his own volition, not by assignment.

Most of the work of the student, however, is done at his own time in a study space, not necessarily enclosed, with a tutor present in the room to provide needed assistance. Under this plan, the teacher (a) is freed from a crowded schedule of repeated sections of a course; (b) is available for small-group and personal interaction with his students; and (c) has time for more intensive planning of the materials to be presented both in the assembly sessions and in personal conferences with the student.

Computer-Assisted Instruction. While the use of computers in college and university administration has now become rather commonplace, their actual use as adjuncts to instruction at that level appears still to be quite rare and largely in an experimental stage.

One special instructional use of computers is sometimes found in listening laboratories equipped with dial access facilities involving remote stations. Still another instructional computer application is found with the student response systems installed in several multi-media classrooms observed in various parts of the country. Perhaps a more usual instructional use of computers is in connection with examinations. The computer has several significant advantages in correcting and analyzing examination results. It provides the instructor and the student with rapid, even instantaneous, reports on the student's total performance on an examination. In addition, computers can provide detailed diagnostic reports on the performance of individual students, enabling the instructor to make individual prescription of study activity for each student; test items can be evaluated and improved in a similar way, after it is known what proportions of students, in each significant segment of the distribution of scores, answered questions correctly.

One newly developed technique involving use of computers in other than a straight instructional situation is "Selective Dissemination of Information." This has exciting potential for any group of workers who need to keep up to date with the most recent knowledge in specific fields. This technique involves (1) a group of readers who are competent to abstract articles in journals as rapidly as they come out; (2) a computer that can store the abstracts, bibliographical entries, and a series of key call words for each entry; (3) subscribers who can develop an SDI profile for themselves, including all the key call words about which they wish to be informed. Each week, with this plan, abstracts from the previous week's journals are fed into the computer; the profiles of the subscribers are scanned, and cards are printed giving each subscriber the abstract and reference information for each article dealing with topics in his profile.

At the beginning of 1967, after only a very few years of experimentation with the medium, several tentative observations about the potential of true computer-assisted instruction seem to be justified:

1. It is now possible to present either complete courses or supplementary exercises to college students by means of computer dialogue. Such course material can be made available a considerable distance from the controlling central computer.
2. The records that computers can provide about the successes and difficulties of each student working through a course will be of crucial importance in improving course materials, no matter in what mode the course will later be presented.
3. Only a very few complete instructional programs for computers have been developed. Before computer-assisted instruction can be made



available to large numbers of students and in most disciplines, a great deal of developmental work is needed.

4. The installation of computer-assisted instruction terminals at present is very costly, although expansion of the number of courses and of student terminals, as well as increased experience, will surely reduce the cost. Further experimentation is generally recommended, both because of the light this kind of research can throw on the nature of learning, and in order to determine whether the advantages of computer-assisted instruction balance its economic costs.
5. The available computer hardware is capable of caring for the instructional calls of 1,000 or more students in several disciplines at one time, without significant delay for any student. The present lack is in variety of software (programs), and in student consoles.
6. An outstanding advantage of computer-assisted instruction is the provision of detailed records of the progress of individual students, so that the program itself can be constantly improved and revised, examinations can be improved, and individually prescribed exercises can assist each student to learn at his own best rate.
7. Perfection of a fully flexible program of instruction along the lines under investigation at the University of Illinois and the Pennsylvania State University would free instructors for much more individual and small-group instruction, and so would increase the effective amount of instruction available to each student.
8. The promise of the technique has been sufficiently demonstrated that continued experimentation in additional institutions should be encouraged. The HEMS staff realize that the present cost and complexity of equipment are discouraging aspects of the medium. It is probable, however, that additional experience will reduce both cost and complexity to the point at which computer-assisted instruction might become the most economical and effective type of programmed instruction. Continued experimentation to discover the limits of this potential appear to be justified.<sup>5</sup>

Special Multi-Media Facilities. The several special types of multi-media facilities that have been developed in institutions of higher learning represent efforts to solve certain problems associated with instructional uses of new media. Included in this category are the single, generously-equipped classroom, the auditorium designed to accommodate large-group presentations backed with appropriate audiovisual elements; and the increasingly popular classroom building containing several multi-media classrooms served by central new media facilities (usually in the core).



Typically, a multi-media installation will combine in a hexagonal or octagonal building a series of triangular rooms of comparatively large capacity (75 to 300 students), surrounding a projection core in which equipment is provided for projection of films, slides, videotapes, and off-the-air or closed-circuit television onto a transparent screen of large size at the front of each room. The multi-media room does enable instructors to realize the goal of quality in large-class instruction--but at a price. Effective utilization of the multi-media installations seems to require that the instructor be assisted by several technicians. In addition, the appropriate use of the equipment afforded in the multi-media room requires planning and rehearsal time of the instructor far in excess of that used in preparing the usual lecture.

Transparencies (Overhead Projectors). Few reports of innovative use have been submitted although there was evidence that the large transparency remains one of the most effective and widely used of all of the new media. Two conditions that encourage competent use of overhead projection in teaching are: first, the provision of competent graphic artists and photographers to work with instructors in developing and producing transparencies for class use; and second, consultants with competence both in the audiovisual field and in an academic discipline who would be employed to help instructors analyze their courses and develop ideas for transparencies.

The investment in overhead projection equipment might be one of the most rewarding approaches to improved college instruction. Nearly every instructor could find a use for this technique in his classes. The key condition for effective use, to repeat, seems to be the kind of institution-wide encouragement that is signified by the provision of centrally-budgeted assistance of technicians and faculty persons for the instructor who desires to improve his teaching.

Tele-Lectures. Many colleges have been making excellent use of this technique to avail themselves of the instructional contributions of guests who cannot come to campus, but who are willing to devote some time to a telephone dialogue with a remote class.<sup>6</sup>

One particular program which was reported concerned a medical school related to community hospitals for continuing education programs for medical and para-medical staffs. Charts and slides are sent out to each hospital in advance of the presentation. In addition, the hospitals are encouraged to tape the lectures, so that additional physicians may hear and see the presentation at more convenient times. In this program, "live" listeners may ask questions, and all listeners in the network can hear both the questions and the answers. Tele-writer installations may also be used in such instances to provide at various remote locations accompanying sets of correlated drawings (done by hand and transmitted instantaneously to the distant points of use). These and other imaginative uses of the telephone or telephone facilities suggest numerous opportunities for continuing education and for keeping up to date with most recent developments.

Simulation. The technique of simulation of life situations for instructional purposes was rarely reported as an operational technique in colleges and universities. However, industries associated with education reported experimentation with the simulation

method in the education of business graduate students ("games theory"), educational administrators, and physicians. As an example, school superintendent trainees are provided with a series of "in-basket" problems; their learning experience is to decide what additional information they need to arrive at a decision for action. It seems that simulation technique might be useful with graduate students or even in the continuing education of workers in a field.

Systems. In today's world it is inevitable that we should be concerned with the total process of learning and we are aware that the process is achieved through a system. The system includes all of the equipment, procedures, facilities, program schedules, texts, materials and personnel required to produce the end result. HEMS has paid particular attention to systems:

The economic realities in higher education today require that a proper distinction be made between the acts of teaching and informing. Two things especially seem to be needed: (1) wider understanding of the fact that simple informing may often be performed quite adequately through the use of materials in listening laboratories, computer-assisted instructional systems, multi-media installations, television networks, etc., and (2) a better understanding of the fact that teaching continues to require the in-person contributions of professors in illuminating, elaborating, questioning, and evaluating and in managing the necessary give-and-take involved in exchanging of ideas with students.<sup>7</sup>

In its simplest form, the development of an instructional system for the entire curriculum of an institution of higher learning is likely to involve several procedural steps: (1) Clearly define goals; (2) Define ways of carrying out these goals; (3) Determine functions related to the achievement of those goals that may be performed adequately by: (a) instruments alone -- mechanical, electronic, electrical such as films, recordings, videotapes, (b) non-technical materials alone such as books, programmed texts, syllabi, or (c) human beings; (4) With the "human" functions, further distinguish those most likely to be performed most effectively by: (a) individual study, (b) one or two students working with an instructor, (c) small groups of students working with or without instructors, (d) medium-sized groups, (e) large-sized groups; (5) Study available professorial talent (as well as the non-professorial back-up talent) to discover persons with special capabilities and interest in performing the instructional tasks described; (6) Study the students to discover those who appear to be most capable of profiting from participation in the various alternative types of learning activities; (7) Survey technical and non-technical resources, physical facilities, support services, budgets, and policies with a view toward improving or expanding them; and (8) Evaluate regularly, feed back data change and improve as called for, with due regard to original objectives.

EDUCOM (the Interuniversity Communications Council) is committed to the encouragement of joint efforts among colleges and universities to stay abreast of new developments in communications sciences (particularly the equipment and techniques that are revolutionizing the handling of knowledge) to apply them most effectively to the teaching-learning, research, and internal management problems of institutions of higher learning.<sup>8</sup>

Task forces have been established by this organization to study specific applications of the new technologies to higher education. Among the groups at work on these problems are: (1) Task Force on Information Networks, concerned with the development of operating programs using computer systems for information storage, retrieval, and dissemination; (2) Task Force on Educational Systems and Technology, concerned with the broad spectrum of teaching and learning systems, with emphasis on the inclusion in such systems of mechanical and electrical communication devices; (3) Task Force on Legal Aspects of Educational Technology, concerned with the problems of relationships among authors, publishers, librarians, computer systems operators, network carriers, and scholars; (4) Task Force on Continuing Education, concerned with lifetime learning for professionals in fields such as medicine, nursing, engineering, teaching, and business, as well as in other rapidly changing fields; and (5) Task Force on Computer-Based Systems for Clinical Operations, concerned with the use of computer and elementary systems in clinical health sciences.

Each of the Task Forces has an interest in basic research in communications, involving, for instance, the relative advantages of different modes of communication, limits of human information processing abilities, the channels through which information flows, use of dynamic mathematical models as aids to human thought processes, noncomputational and linguistic uses of computers, and methods of computer search of indexes, abstracts, and full text. The policy is to avoid projects that a single university or one professor could do as well.

#### Implications of the New Media for the Teaching of Library Science

In 1963 another milestone was passed. In that year the graduate library schools of the country participated in a workshop under a U.S. Office of Education grant which resulted in the publication edited by Harold Goldstein, Implications of the New Media for the Teaching of Library Science.<sup>9</sup> The workshop was based on four premises: (1) that one of the competencies required of library school graduates is a knowledge of new media; (2) that, in the face of present shortages of library personnel, educational television offers one means of extending our present limited library education resources to many people who would not otherwise be recruited for the library profession; (3) that there are now available media and teaching devices which have implications for the teaching of library science; and (4) that by definition library educators must be informed concerning the full range of materials and methodologies which have significant implications for library education.

Sara R. Reed, then Library Education Specialist, Library Services Branch, U. S. Office of Education, was workshop summarizer. She reported certain observations which were found to recur:

- (1) When audio-visual methods are used, the spirit in which they are used is important. A teacher should not continue teaching in the same way except for the addition of the new methods. He must not only feel at ease with audio-visual devices, but he must also review and re-evaluate his



course objectives and teaching methodology. Otherwise the new techniques may detract more than they add. (2) Currently the use of audio-visual aids is made more difficult because of their rate of obsolescence and because the bulk of available materials has not been produced for library school courses but must be adapted with varying degrees of success. This is true both of materials produced by the library profession for certain purposes such as library extension or freshman library orientation, and also of those produced commercially and geared largely to elementary or high school rather than graduate school level. (4) Even when faculty members have identified desirable visual teaching aids, many do not have ready access to production centers. For those with heavy teaching schedules the time and effort necessary to obtain these new materials act as deterrents. (5) For some participants, a glossary of terms would be a welcome appendix to the proceedings. (6) Although audio-visual materials can be used effectively throughout the curriculum, such aids along with programmed instruction, were felt to be particularly appropriate at the beginning levels of library education. By these means a springboard of competencies and knowledges could be developed with full attention to individual needs. (7) Finally, speakers and group participants agreed heartily that to substitute audio-visual aids for printed materials is a misuse of these materials. They are, rather, enrichment materials intended to expedite the learning and teaching processes.<sup>10</sup>

Prior to the beginning of the workshop the participants were informed that they would be expected to sit together in small groups to discuss some of the implications, content, and ideas which were presented to them. The best arrangement seemed to be in accordance with the five core course areas. Miss Reed examined the recorder's reports and revealed the following:

(1) Selection of Materials - Adequate multi-media materials centers equipped with examples ranging from effective to defective materials are needed for teaching purposes. Transparencies, films, filmstrips, tapes, and slides are needed to teach principles of building a collection of materials and to dramatize book selection problems, intellectual freedom problems, etc. Some programmed instruction of book selection tools and the mechanics of book selection is feasible.

(2) Reference and Bibliography - In the content of the basic reference course, the administration of reference service in an automated library which is a member of a cooperative reference service must be taken into account. Tapes, teaching machines, transparencies, closed-circuit television, films, and field trips were mentioned as useful devices for developing the knowledges and competencies of reference materials and services.



(3) Cataloging and Classification - All five groups indicated that cataloging and classification is the area most amenable to the use of visuals and programmed instruction. Dean Lancour of Pittsburgh reported that Stone and Osborne are working on a set of transparencies for this course. There are many examples of the use of the opaque projector to teach the problems of cataloging and classifying. Other techniques suggested were filmstrips to teach the function of the card catalog and programmed instruction to teach terminology, professional tools, and the basic bibliographical principles. One word of warning concerned the possibility that the student who uses programmed instruction could develop some inflexibility in regard to the organization of materials. It was pointed out that this tendency could be overcome by emphasis upon the comparative approach.

(4) Introduction to Librarianship - Although Introduction to Librarianship, whether taught as a single course or as units in other courses, does not lend itself as readily to visualization as do some other areas of the curriculum, some schools are using films, film clips, transparencies, and closed-circuit television. In orienting students to librarianship, film loops and tours have been used successfully. One school, for example, finds closed-circuit television a substitute for first-hand observation, particularly in the area of school librarianship. The tele-lecture will probably be used increasingly to utilize off-campus specialists.

(5) History of Books and Libraries - In this area of instruction some teachers feel that the best visuals are the books and manuscripts themselves. Good facsimiles are welcomed when the former are not available. The majority of instructors either have their own slide collections for teaching purposes or are able to borrow slides from a campus collection. A number of people felt that bibliography of films, slides, filmstrips, etc., both materials and sources, including sources for ordering facsimiles, would be useful. As was noted above, the history of books and libraries was one of the areas for which participants generally seemed to feel that a carefully developed package of audio-visual materials would be gratefully received. While acknowledging that some effective programmed instruction might be possible, the participants in this group favored keeping this a reading course designed to "place the librarian in his cultural context." They prefer that emphasis upon specific factual content be minimized.<sup>11</sup>

The workshop, through meaningful discussions, demonstrations, and addresses, met the objectives to which it had addressed itself. The proceedings resulted in a publication that will be particularly useful for a long time to come.

### Conclusion

Professional education for work in the communication and information service professions should reflect our media service requirements because these are defined in terms of function. Media functions which must be performed within schools and colleges include the following: (1) Research and experimentation, which involve both instructional uses of media as well as the study of service arrangements developed to satisfy the media needs; (2) Production of new materials, which takes into account special requirements of single types of media as well as the "conceptual interlock" (which increasingly must guide preparation of new materials in terms of anticipated instructional use); (c) Distribution which includes materials and equipment of all kinds; (d) Counseling and training, which improve instructional uses of media; (e) Demonstration and display service, which is more adequate at least than that provided in schools and colleges under more typical present-day arrangements (which place responsibility for this work in the office of a harried superintendent or busy principal or, on a campus, in the office of a coordinator of public events); (f) Computer applications, which will make possible the harnessing of the full range of modern techniques for storage, retrieval and correlation of data masses.<sup>12</sup>

The constant reiteration of the word "research" is to be found in library literature and professional meetings of all kinds. Most important for our purpose is continuing self-study and research in order to provide better background, greater competency, and broader application of what is happening as a result of investigation in all fields which need to be related to the fullest dimensions of librarianship.

Perhaps the only way to overcome the inertia which faces all of us in library education today is by experimentation in various parts of the program and then, after careful evaluation, determining which changes are necessary in our own programs. It would appear that the excitement of the new challenge and increased responsibility might in and of itself be sufficient to provide the stimulus for change in library education today.

## REFERENCES

- <sup>1</sup>Toward Improved Learning (Atlanta, Ga.: Public Health Service Audiovisual Facility, 1967).
- <sup>2</sup>James W. Brown and James W. Thornton, Jr., New Media in Higher Education (Washington, D.C.: Association for Higher Education and National Education Association, 1963).
- <sup>3</sup>Media Activity Inventory - Directory, February, 1967 (San Jose, California: Higher Education Media Study, 1967).
- <sup>4</sup>James W. Brown and James W. Thornton, Jr., Instructional Uses of Educational Media in Higher Education: A Critique (Washington, D.C.: Association for Higher Education and National Education Association, 1967). (Ditto copy, approximately 100 sheets, limited distribution.)
- <sup>5</sup>Brown, Instructional Uses of Educational Media in Higher Education: A Critique, op. cit., pp. 7-5, 7-6.
- <sup>6</sup>Tele-Lecture. Tele-Lecture. (Bell Telephone System, 1963).
- <sup>7</sup>Brown, Instructional Uses...., op. cit., p. 12-1.
- <sup>8</sup>"A Look at Where EDUCOM Now Stands--and the Goals It Hopes to Accomplish," EDUCOM, II (January, 1963), 2-3.
- <sup>9</sup>Harold Goldstein, ed., Implications of the New Media for the Teaching of Library Science. Monograph series No. 1. (Urbana, Ill.: University of Illinois Graduate School of Library Science, 1963).
- <sup>10</sup>Ibid., p. 118.
- <sup>11</sup>Ibid., pp. 118-19.
- <sup>12</sup>Ibid., pp. 30-31.

INTRODUCTION TO MODERN TECHNIQUES OF BIOMEDICAL COMMUNICATION  
by Ralph T. Esterquest

Points from the Group Discussion

---

1. Health sciences librarianship is concerned with a broadened definition of the biomedical library comprised of audio-visual techniques, medical illustration and medical writing unified in the learning resources center. Concern should not focus on the housing of components of this information system, but on the preparation of a union catalog to make all elements available to users.
2. The library can coordinate the various elements of several service agencies. The biomedical library is an individual learning resource center but it is also allied to other processes involved in group learning which may use the same media.
3. Probably the biggest emphasis in medical education is on continuing education. As the use of non-book materials increases, there is a parallel increase in the need to coordinate, to cooperate, and to use pooled resources.
4. The hardware required to disseminate new media information is important but software is even more important. Recognition should be given to the time and money involved in the creation of computer-assisted instruction but the emphasis should be on its value as an efficient and ultimately economical mechanism for communication to the user population.
5. How much preparation in medical communication should the librarian receive? What should be done to expose students to the wide field of biomedical communication? Should this instruction be part of the library school's curriculum? Should the curriculum in this area draw upon the resources of other units of the university?



## CONCLUSION AND SUMMARY

The conference explored a wide spectrum of information, problems, and goals indicating the direction to possible solutions. The most important contribution was the creative concern with change, change within the Health Sciences and change within Librarianship.

The critical factor in meeting the challenges facing health sciences libraries is, as in the professions generally, availability of qualified personnel. Quality and quantity of qualified personnel depend on educational opportunities.

After much searching, and a degree of modification within individual positions, the consensus seemed to be that the health sciences librarian was first a librarian, and secondly, that he worked within an environment which serves the diverse needs of many groups: teachers, practitioners, patients, communities, etc. The identification, recruitment and education of the health sciences librarian should be within the context of general library education and closely articulated with all related areas in the university.

It is agreed that the curriculum requirements are: (1) basic principles and techniques of librarianship, (2) structure, organization and management of medical library resources, facilities and technology, (3) subject content of biomedicine and (4) environmental setting of medical practice, education and research. The library educators were of the opinion that it is possible to encompass the specialization within the one year allotted for the master's degree, though they did not rule out lengthening the time.

After careful scrutiny of the Working Papers and emphasis on the Points from the Group Discussions, the editor has selected four main headings for further consideration in the field of education and health sciences librarianship. The items selected and listed below are organized under four headings as follows: Education for Health Sciences Librarianship, Health Sciences Library Education in Relationship to General Library Education, Emerging Responsibilities in Information Science and in Biomedical Communication, and Levels of Service in Health Sciences Librarianship.

### I. Education for Health Sciences Librarianship:

1. Students should be taught to adapt to the evolving field of health sciences librarianship. This involves the teaching of adaptability, the ability to perform in changing situations. A curriculum concerned with problem-solving, taught in a meaningful context, is one effective means of teaching adaptability. It is only when you reach a point where you are dealing with real problems that you become aware of the need for basic principles.
2. Two positions can be taken in adapting to this change: (a) The conservative position, in which one can reject change and attempt to preserve the status quo; or, claim that it is impossible to predict change. (b) the liberal position in which one can argue that certain directions of change can be identified, certain trends can be predicted, and that it is possible to develop training programs which will prepare individuals for change.

3. Education for librarianship should be evaluated in terms of the end product - service. Will an educational program designed with the user as the ultimate criterion necessarily resemble the current profession-oriented program?

## II. Health Sciences Library Education in Relationship to General Library Education:

1. The systems approach is useful in curriculum development. Library education should utilize systems analysis in evaluating present goals, functions, results and future directions.
2. The library school, as a part of the university, should articulate its curriculum with other colleges, departments, schools, etc. A creative dialogue should also be maintained between the library school and practicing librarians.
3. The management skills and creative direction of a health sciences librarian are derived perhaps 90% from general preparation and 10% from special preparation. Library education has the responsibility to identify the 10% and to determine where and at what levels participation of health science faculty in education programs for the health sciences librarian is essential.
4. How can additions be made to an already full library education curriculum? Could sufficient time for teaching of principles be found if the teaching of methodology were diminished? If students are grounded in theory, will they be able to apply this theory to specific situations? Is there some better way in which theory and methodology can be combined in graduate instruction for the health sciences librarian?
5. What should be the subject preparation? The more the student knows about the subject matter, the more capable he will be. However, this subject background can be acquired, building upon the ability to think analytically, motivation and capability for further study, and personality.
6. Students should share an intellectual exchange from differing viewpoints. In upper division or graduate courses, there is a great deal of interplay between individuals - they discover how the other person thinks. The sooner people who are destined for later contact with one another come to appreciate the variations in attitudes that distinguish the physician from the basic scientist, the historian, the librarian, etc., the better it is for their future relationships.
7. Attention should be given to the history of medical communication as it differs from the social history of medicine. Medical communication deals with man's attempts to provide the next generation with both the facts he has uncovered and the relationships he thinks he discerns between the facts. Is it realistic to include this in general course content of the

library school or should it be reserved for the health sciences librarian exclusively? Should the history of medical communication be taught as a separate course or should it be incorporated into all courses taught?

8. In the development of educational programs, recognition should be given to the diversity of needs and to the diversity of roles to be filled in future information systems. To what extent is there a generic core common to these roles; to what extent must a specialized program be developed?
9. A number of medical schools are considering the possibility of educating students in health sciences communication. These schools are not equipped to do this independently and they should utilize existing library education resources. Does this concern on the part of medical schools imply shortcomings in the existing system? It is important that a substantial part of the education of health sciences librarians be conducted in the environment where the individual will spend his professional life.

### III. Emerging Responsibilities in Information Science and in Biomedical Communication:

1. It is important for health sciences libraries to apply data processing to their operations as well as to learn where data processing is not feasible. Currently most such applications are in the planning stage.
2. What is the relationship of health sciences librarianship to information science? Programs of education in this field have clear relevance to library needs and requirements, but how closely do they interrelate?
3. Indications point to computer services being made available as public utilities. It can be anticipated that computer time will be a public utility in ten to twenty years. It will be possible for libraries to connect with a national system comparable to existing telephone systems, without necessarily knowing what machines are used or who controls them.
4. Health sciences librarianship is concerned with a broadened definition of the biomedical library comprised of audio-visual techniques, medical illustration and medical writing unified in the learning resources center. Concern should not focus on the housing of components of this information system but on the preparation of a union catalog to make all elements available to users.
5. How much preparation in medical communication should the librarian receive? What should be done to expose students to the wide field of biomedical communication. Should this instruction be part of the library school's curriculum? Should the curriculum in this area draw upon the resources of other units of the university?



6. The hardware required to disseminate new media information is important, but software is even more important. Recognition should be given to the time and money involved in the creation of computer-assisted instruction but the emphasis should be on its value as an efficient and ultimately economical mechanism for communication to the user population.
7. Probably the biggest emphasis in medical education is on continuing education. As the use of non-book materials increases, there is a parallel increase in the need to coordinate, to cooperate, and to use pooled resources.

#### IV. Levels of Service in Health Sciences Librarianship:

1. Health sciences libraries are called upon to provide information to facilitate communication in support of research, teaching, and patient care. More knowledge of the functions of the health sciences community would enable librarians to specify what kinds of information and services ought to be provided. Functional analysis of the environment is essential to the planning of an educational program. This requires job analysis and systems analysis, which will provide a basis for the determination of what the job is, who should do the job, and what should not, as well as what should be done. Existing analyses, generated by individual libraries, are useful, but emphasis must be on the entire system of health science libraries.
2. Service is provided at different levels. These levels should be identified and described. It may be that our best prepared personnel belong in the hospital where the most direct contact with the information consumer takes place.
3. The economic bases for support of the health science library in the hospital must be identified. Is this the responsibility of the hospitalized population? Is it the responsibility of physicians? Is this a public information service of state government, of the federal government?
4. The hospital librarian works with the same scholarly record as the medical librarian but there is a difference in the quantity of material actually present. The primary difference is one of emphasis rather than one of technique and purpose. The hospital environment also requires a different attitude toward service because of the pressure of time.
5. Hospital health sciences librarianship is in a kind of limbo. We need to train manpower to operate these libraries, and this training may or may not lead to an academic degree.



6. An analogy can be made to the needs filled by the land grant colleges. This movement provided farmers with the opportunity to acquire, through short courses, knowledge about scientific farming with the objective of producing better agriculture. Can a similar approach be developed for the hospital health science librarian?
7. Educational programs must be developed in relation to a multiplicity of forces influencing biomedical communication at various levels, in a variety of agencies, and with a diversity of users.
8. If library education were to produce hospital health science librarians, would they be accepted by the medical community? Would there be enough demand and would there be financial resources to employ these people?
9. Should library schools train library technicians as well as librarians? Should such training take place elsewhere?
10. Is a systems approach applicable to hospital health science librarianship? Ignorance of systems, and their resulting benefits, perpetuates the isolated library.

The common denominator throughout the conference was the recognition that the only justification for library service is to meet the library needs of individuals. This is best realized when all needs are considered and good service results. By utilizing existing resources, human and otherwise, we can meet the demands of today and also anticipate the demands of the future. This encompasses recognition of the functions of the various personnel needed in a comprehensive program of library services designed for the Health Sciences: the generalist, the specialist, the technicians, etc.; and the variety of consumers: the professional, para-professional, patient, etc.

As a final note, here is an evaluation offered by one of the participants. He said: "The Conference was important not only for medical librarianship, but for all special librarianship. It established an objective for medical library education which, with very little alteration, may be translated into an objective for all special library education. Such education should place the librarian on a new level of competence which will merit cooperation and respect from other learned professions. It should eventually develop a cadre of librarians who can make the library an integral part of educational, research and development programs in education, industry and Government."

Irving Lieberman

APPENDIX A

CODE FOR THE TRAINING AND CERTIFICATION  
OF MEDICAL LIBRARIANS

Medical Library Association, Inc.

Reprinted from BULLETIN of the Medical Library Association  
Vol. 52, No. 4, October, 1964  
Printed in U.S.A.

1. For the purpose of improving the standards of medical librarianship, the Medical Library Association hereby establishes a Code for the Training and Certification of Medical Librarians.
2. In accordance with the provisions of Article VIII of the Bylaws of the Association, the Committee on Standards for Medical Librarianship will grant Certificates of Medical Librarianship to duly qualified persons under the conditions stated below.
3. Certification is understood to give evidence of special training or recognition of special knowledge and experience in the field of medical librarianship.
4. Certificates granted or issued by the Association shall not confer or purport to confer upon any person any degree, legal qualification, privilege, or license, nor purport to be issued by or in pursuance to or by virtue of any statutory or governmental sanction or authority. Recipients of Certificates shall not by virtue thereof become members of the Association nor shall they be entitled by virtue thereof to vote on any matters whatsoever.
5. The following types of certificates will be granted under the following conditions.
  - a) Certification at Grades I, II, and III, corresponding to approved levels of medical library training, may be conferred by the Committee on Standards for Medical Librarianship on those presenting proper credentials of completion of prescribed training. Grades of training as approved by the Medical Library Association are:
    - Grade I: The minimum requirements for certification at Grade I are a bachelor's degree and graduation from an American Library Association-accredited fifth-year library school, plus one of the following:
      - A. Successful completion of an MLA-approved course of instruction in medical librarianship; or
      - B. A passing grade on an examination covering the materials usually included in such a course; this examination to be administered each year by the Subcommittee on Curriculum; or
      - C. Successful completion of an MLA-approved medical library internship.
    - Grade II: The minimum requirements for certification at Grade II are a bachelor's degree; graduation from an American Library Association-accredited fifth-year library school; successful completion of an MLA-approved course of instruction in medical librarianship (or passing grade on an examination as outlined for Grade I) plus one of the following:
      - A. Successful completion of an MLA-approved medical library internship; or
      - B. An earned master's degree from a university of recognized standing in one of the disciplines applicable to life sciences librarianship, to librarianship, or to documentation, and one year of professional experience in a library of recognized standing.
    - Grade III: The minimum requirements for certification at Grade III are a bachelor's degree and graduation from an American Library Association-accredited fifth-year library school, plus both of the following:

- +
- A. An earned doctoral degree from a university of recognized standing in one of the disciplines applicable to life sciences librarianship, to librarianship, or to documentation; and
  - B. Five years of professional experience in a medical library of recognized standing.
- b) Individuals holding foreign degrees or with unusual backgrounds may apply to the Subcommittee on Certification for consideration of their credentials in terms of equivalencies.
6. Applications for Certification will be received by the Subcommittee on Certification, which will evaluate the credentials of the applicants and make recommendations to the Committee on Standards for Medical Librarianship.
  7. Each applicant for certification shall be required to sign the following pledge:  
 "I agree to hold said Medical Library Association, Inc., and its members, examiners, officers, and agents free from any damage or claim for damage or complaint by reason of any action they, or any of them, may take in connection with this application, any examination, the grade or grades given with respect to any examination, and/or the failure of said Association to issue to me a Certificate of Medical Librarianship."
  8. Any certificate may be revoked at any time, for cause, by order of the Committee on Standards for Medical Librarianship. A hearing shall be granted on request of the person whose certificate is in question.
  9. A nominal fee shall be paid to the Medical Library Association for each certification issued by the Committee on Standards for Medical Librarianship.

#### DEFINITIONS

1. "One year" of professional experience in a medical library shall mean professional work totaling 11 months of full-time work.
2. "Professional experience" shall mean actual participating professional experience in library duties described as professional in the Descriptive List of Professional and Non-Professional Duties in Libraries of the American Library Association, compiled in cooperation with the MLA Committee on Task Analysis (see Bulletin of the Medical Library Association 36: 257, 1948; and 38: 339, 1950).
3. "Approved course of instruction in medical librarianship" shall mean a formal course of training given in an ALA-accredited school of library science and approved by the Subcommittee on Curriculum of the MLA Committee on Standards for Medical Librarianship.
4. "An examination covering the materials usually included in such a course" shall mean an examination prepared and kept up to date by the Subcommittee on



Curriculum. Whereas the selection of applicants eligible to take the examination shall be at the discretion of the Subcommittee on Certification, the selection of time, place, monitor, grading, etc., shall be made by the Subcommittee on Curriculum.

5. "Approved medical library internship" shall mean training of at least six months duration in a medical library whose training program has been approved by the Subcommittee on Internship of the MLA Committee on Standards as meeting the following minimum requirements:
  - a) The program must be designed as an educational experience for the participants; under no circumstances may lessening of the staff load of the sponsoring library be an objective.
  - b) The program must provide for participation and instruction in all phases of the library's activities, with emphasis on professional tasks and with only so much attention to nonprofessional work as may be required to familiarize the intern with work routines which he may sometime be called upon to organize and supervise.
  - c) The program should include a series of seminars wherein library problems, both specific and theoretical, may be discussed in the context of the sponsoring library's practices, the practices of other libraries, and the library literature. The program should provide opportunities to pursue formal courses in the life sciences, language study, or documentation. The program should provide for guided visits to nearby scientific installations and subject-related libraries and bookstores and for attendance at professional meetings.
6. "Foreign degrees" shall mean those granted outside the United States and Canada.
7. "Medical library of recognized standing" shall mean a library which has met or is capable of meeting requirements for institutional membership in the Medical Library Association.

#### PURPOSE OF CERTIFICATION

The purpose of Certification is to:

1. Assist in improving the quality of medical librarianship.
2. Establish minimal educational and training standards in this special field.
3. Determine whether applicants have received adequate training.
4. Certify to the competence of those medical librarians who meet the requirements.

## BENEFITS OF CERTIFICATION

1. Certification will form a criterion by which interested professional and lay groups may judge the qualifications of a medical librarian.
2. Certification will be a reliable guide in the choice of medical librarians.
3. Qualification of applicants for Certification will indirectly result in improved medical librarianship, and
4. Elevate the bibliographical standards of the medical and allied professions by improving professional library service.

## APPLICATION FOR CERTIFICATION

1. The application form shall be sent only on request.
2. The completed application form, when returned, must be accompanied by the registration fee of \$5.00, which shall be forfeited if, for any reason, the qualifications of the applicant are unacceptable to the Subcommittee on Certification and Certification is not granted. An additional fee of \$10.00 shall be charged for the Certificate. All checks and money orders should be made payable to the Medical Library Association, Inc.
3. The signature of one authoritative voucher will be required to indorse the statements contained in the application form (see Item 13 on the application form).
4. Applicants for Certification in Grades I, II, or III shall attach a transcript of academic records for both library school and the special course in medical librarianship.
5. Applicants holding foreign degrees must attach a transcript or its equivalent for each degree obtained abroad. A detailed summary of all professional library experience of applicants holding foreign degrees must accompany the transcripts. Other credentials may be required at the discretion of the Subcommittee on Certification.
6. Each applicant for Certification shall be required to sign the pledge which forms Section 7 of the CODE and which is incorporated into the application form (Item 14).
7. Each applicant for Certification will be expected to agree to abide by Section 4 and Section 8 of the CODE as printed above and as incorporated into the preamble of the application form.

## APPLICATION APPROVED

When an application has been approved by the Subcommittee on Certification, the application form containing the Subcommittee's recommendations for Certification shall be forwarded to the Chairman of the Committee on Standards for Medical Librarianship, who shall then notify the applicant that the additional fee of \$10.00 payable to the Medical Library Association, Inc., must be sent to the Chairman of the Committee on Standards for Medical Librarianship before the Certificate will be distributed.

## APPLICATION DISAPPROVED

If an application does not meet the requirements for the type of Certification designated, a letter of explanation stating the reason for its nonacceptance shall be sent to the applicant by the Chairman of the Committee on Standards for Medical Librarianship.

## History of MLA Certification

By Mary Louise Marshall

The Medical Library Association had long realized the need for special training in the preparation of librarians for service in the subject field of medicine and its allied sciences. In recognition of this need the presidential address on Training for Medical Librarianship at the meeting of the Association in New Haven in March of 1964 invoked a lengthy and enthusiastic discussion. Much of this discussion emphasized not only the need for special training and the methods by which it might be achieved, but also the natural accompaniment of such a program, that is, the adequate and official recognition of ability and competence in this subject field. Library work by means of certification according to standards of medical librarianship as approved by the Medical Library Association.

A Committee on a Training Program for Medical Librarians was appointed to study the matter and make recommendations to the Association at its next meeting. A questionnaire was circulated among the professional members in an attempt to gather basic ideas from which recommendations might be formulated. As a result, a code for training of medical librarians was presented to the Association at its meeting in Cleveland in 1947 and was approved. The accompanying code of recommendations regarding certification was referred back to the Committee for further investigation and study.

The development of various phases of the work in the course of the study led to the recommendation of an enlargement of the Committee into a general committee and four subcommittees to deal individually with matters pertaining to recruitment, curriculum, internship, and certification. A change in the name of the Committee to Committee on Standards for Medical Librarianship was suggested. The plan for provision of

certification was revised. These changes were presented to the Association at its meeting in Philadelphia in 1948 and received the official approval of the Association. The Committee was instructed to prepare a bylaw covering its recommendations for the Committee's reorganization and for the provision of certification according to standards of medical librarianship.

Such a bylaw was so prepared and presented to the Association assembled in Galveston in 1949. The bylaw was passed by vote of the necessary three-fourths majority of the delegates of the Association present.

For five years, Charter Certification was granted, on application, to those who on the day of the program's adoption or within five years thereafter had completed five years of professional experience in a medical or allied scientific library. Charter Certification closed on April 13, 1954.

Special Certification, previously granted to those applicants with unusual backgrounds or holding foreign degrees, was discontinued on June 2, 1964. These individuals can now be certified at one of the grade levels as noted in the above Code.

The Code was revised in 1956 and again in 1964.



EDUCATION AND TRAINING FOR THE VETERANS  
ADMINISTRATION LIBRARY PROGRAM

A Paper Prepared in Connection with the  
Conference on Education for Health Sciences Librarianship

By

Henry J. Gartland, Director  
Library Services  
Veterans Administration  
Washington, D. C.

In contradistinction to the authors of most of the papers prepared for this conference, I represent an organization which is a major consumer of the products of the biomedical or health science librarianship curricula. For an understanding of our manpower and training requirements, some background on my organization is in order.

The U.S. Veterans Administration, which is charged with the administration of Federal laws pertaining to veterans and veteran affairs, is organized in three operating departments: Medicine and Surgery, Veterans Benefits, and Data Management.<sup>1</sup> The Department of Medicine and Surgery operates the medical network of hospitals, outpatient clinics, domiciliaries, restoration centers, and nursing care units. The Department of Veterans Benefits is responsible for the administration of veterans compensation and pension, vocational rehabilitation, home, farm, and business loans, life insurance, educational assistance, and guardianship. All ADP capabilities and activities for the VA are managed by the Department of Data Management.

In the Department of Medicine and Surgery, library service in the VA is tripartite, encompassing service to patients, to medical and paramedical staff, and to employees.<sup>2</sup> Patients' libraries furnish recreational and educational materials to patients as an adjunct to their care and rehabilitation. Medical libraries give reference, bibliographic, and other services to medical and paramedical staff. In addition, library service is provided all employees in connection with their official duties, and materials in the areas of job improvement and self-development are maintained for the use of employees.

The VA library program is staffed by 368 librarians, 93% of whom are college graduates. These librarians rank fifth among all professional groups in the agency in years of education attained. By 1968, one-third of our librarians will be 60 years of age or over while only about 10% will be under 35.<sup>3</sup> With only 14 new graduates from library schools going into the professions to serve in all hospitals including the VA in 1965, recruitment and training as well as continuing education at the same time as powerful external and internal forces are affecting VA library services, necessitate a rethinking of our program.<sup>4</sup>

To ensure that the library service remains responsive to the changing and expanding information and data requirements of education, research, and clinical programs, the library in concert with other components of the agency is studying the scientific and technical information subsystem (medical library) as part of the long-range plan for the VA Total Information Processing System (TIPS).<sup>5</sup>

The VA library system, which is comprised of

- a. Central Office administrative staff
- b. Central Office service unit
- c. Centralized processing unit for cataloging and periodical procurement
- d. Station units,

must be supportive of the information and data requirements of VA research, training, and clinical programs.

This network of information and data (re) sources with switching between units by means of an integrated manual, semi-mechanized, and computer-based operation is envisioned as the access mechanism to all the information resources of the agency regardless of their format, source, location, or control within or outside the agency.

The objectives of the study which we are undertaking as our next step are:

1. To provide improved service in meeting an expanding and changing work load.
2. To develop a centralized resource control in conjunction with our well-known centralized catalog processing unit.
3. To acquire the capability of interfacing with other library and information networks and to build a foundation for the development of future interfaces by means of the experimental testing of alternatives.

The first phase of the present study will be the identification and analysis of the specific functions in the total library system. Concurrent attention will be paid to resource control, including acquisition, cataloging, storage and distribution, and service functions such as anticipated demands against the system, optimum format of demands, possible alternatives within the demand structure, standardization of inquiry codes, and what outputs are required. The consideration of the relationships and functions within the system of other components of the VA will conclude the first phase of the study.

The second phase of the study will be a period of experimentation with different alternatives for both functions within the library system and interfaces outside the VA. Within the VA areas to be investigated will include input, output, retrieval techniques, possible new services, dissemination techniques, system by-products, distribution and storage, educational and medical research program support requirements. Outside interfaces to be explored and articulated, with particular attention to the methods of access will include national libraries, regional libraries, information services of government, professional societies, and commercial organizations, EDUCOM, and affiliated medical schools.<sup>6</sup>

I will list here some of the steps which we are currently taking for the training and re-training of biomedical health science librarians:

1. Annual conferences of chief librarians to update them both in VA educational, research, and clinical programs and in VA library services. Distribution of the proceedings of the conferences disseminates summaries of the papers and discussion throughout the field.
2. VA-supported work-study programs in cooperation with a group of library schools throughout the country. This program is envisioned as a means of providing a field work experience with pay for trainees who may be recruited for the library system.

3. Utilization of VA facilities in conjunction with National Library of Medicine-supported and other training programs for biomedical and health science librarians and information specialists. We are presently developing guidelines for the utilization of VA facilities in these training programs. Hopefully, implementing instructions for P.L. 90-31 will enable us to participate in the Public Health Service in further training activities.<sup>7</sup>

It is our aim to take the initiative to make certain that the Veterans Administration retains its leadership in service and support of the nation's health sciences through responsive, flexible, and up-to-date biomedical communications services.



## REFERENCES

- <sup>1</sup>U.S. Veterans Administration. Organization Manual of the Veterans Administration. Washington, D. C., The Author, 1966.
- <sup>2</sup>U.S. Veterans Administration. Department of Medicine and Surgery. Professional Services. Manual M-2, Part XIII. Medical and General Reference Library Staff. Washington, D. C., The Author, 1966. v.p.
- <sup>3</sup>Henry J. Gartland, "The Veterans Administration Library Program," Bulletin of the Medical Library Association, (In press).
- <sup>4</sup>Carlyle J. Frarey, "The Placement Picture - 1966," Library Journal, XCII (June 1, 1967), 2131-36.
- <sup>5</sup>U.S. Veterans Administration. Department of Data Management. Long-Range Plan for a VA Total Information Processing System. LRP No. 30-01-00. Proposed Revision January 1967. Washington, D. C., The Author, 1967. v.p.
- <sup>6</sup>U.S. Veterans Administration. Chief Data Management Director's Project. Project Protocol. Project No. 7-36-06A0-1. Beginning date: September 1967.
- <sup>7</sup>U.S. Congress. 90th. Public Law 90-31. Mental Health Amendment of 1967.

APPENDIX C

BIOGRAPHIES  
of  
PARTICIPANTS

LESTER E. ASHEIM

Director, Office for Library Education, American Library Association, 1966 to date.  
B.A., University of Washington, 1936; B.A.L.S., University of Washington, 1937;  
M.A., University of Washington, 1941; Ph.D., University of Chicago, 1949.

Career Summary:

Junior Reference Assistant, University of Washington, Seattle, Washington, 1937-41;  
Librarian, U.S. Federal Penitentiary, McNeil Island, Washington, 1941-42; U.S.  
Army 1942-45; Regional Librarian, U.S. Federal Public Housing Authority, Seattle,  
Washington, 1946; Assistant Professor, Graduate Library School, University of  
Chicago, 1948-52; Visiting Lecturer, Graduate School of Library Science, University  
of Illinois, Urbana, Illinois, 1949 (Summer); Dean of Students, Graduate Library  
School, University of Chicago, 1951-52; Dean and Associate Professor, Graduate  
Library School, University of Chicago, 1952-61; Director, International Relations  
Office, American Library Association, 1961-66.

Additional Professional Activities:

Recipient, Intellectual Freedom Award for 1966, Illinois Library Association;  
Distinguished Alumnus Award for 1966, University of Washington School of  
Librarianship.

Member, AAUP, ALA, Illinois Library Association, SLA; Phi Beta Kappa, Beta Phi Mu.  
Author, numerous articles and monographs including:

- [Ed.] Core of Education for Librarianship. ALA, 1954.  
[Ed.] Forum on the Public Library Inquiry. Columbia University Press, 1950.  
[Ed.] The Future of the Book. University of Chicago Press, 1955.  
The Humanities and the Library. [Lester Asheim and associates]. ALA, 1957.  
[Ed.] New Directions in Public Library Development. University of Chicago, 1957.  
[Ed.] Persistent Issues in American Librarianship. University of Chicago, 1961.  
Librarianship in the Developing Countries. University of Illinois, 1966.

## DOROTHY BEVIS

Associate Director and Professor, School of Librarianship, University of Washington, Seattle, 1947 to date. B.A., Pomona College, 1927; B.S. in L.S., University of Southern California, 1947; M.A., University of Washington, 1951; pre-doctoral studies, Columbia University, School of Library Service, 1959-60.

### Career Summary:

Research and Sales, Dawson's Rare Book Shop, Los Angeles, California, 1928-39. Editorial Chief, San Pasqual Press, Pasadena, California, 1939; Editor, University of California Press, Berkeley, 1940-43; Lt. Commander, USCG (WR) in charge of women's personnel, 13th Naval District, 1943-46; Science and Technology Assistant, Long Beach Public Library, California, 1948; Coordinator of Adult Service, Glendale Public Library, California, 1949; Branch Librarian, Seattle Public Library, summer, 1952; Special Adult Education assignment, Seattle Public Library, 1953; Visiting Professor, University of Southern California, 1951; Visiting Lecturer, School of Library Service, Columbia University, 1960.

### Additional Professional Activities:

Chairman, Northwest Library Public Relations Council, 1948-51; A.L.A. Subscription Books Bulletin Committee, 1955-59; A.L.A. representative to American Standards Association, 1958, 1965; Recording Secretary A.L.A. Library Education Division, 1961-62; Publications Committee of LED, 1963-66; Assistant Editor of Resources and Technical Services, 1960-64; A.L.A. Councilor at Large, 1965-68; Editorial Board, Journal of Education for Librarianship, 1964-; Past President of the Association of American Library Schools; Consultant on Library Education to the Escuela Americana Medellin, Colombia; in charge of survey of the libraries of the State of Washington, 1966-67.

Member, AAUW, AALS, ALA, PNLA, WLA, and WSASL. Author, numerous professional articles and monographs. The Libraries of the State of Washington, in process, 1967.



CHARLES W. BODEMER

Associate Professor of Biomedical History and Chairman, Department of Biomedical History, School of Medicine, University of Washington, Seattle. B.A., Pomona College, 1951; M.A., Claremont Graduate School, 1952; Ph.D., Cornell University, 1956.

Career Summary:

United States Marine Corps, 1944-47; Teaching Fellow, Dartmouth College, 1952-53; Teaching Fellow, Cornell University, 1953-56; Instructor, Assistant Professor, Associate Professor of Biological Structure, School of Medicine, University of Washington, Seattle, Washington, 1956-67; Associate Dean, School of Medicine, University of Washington, Seattle, Washington, 1963-67.

Additional Professional Activities:

National Science Foundation, Division of History and Philosophy of Science Review Board, 1956-; Member, State Basic Science Examining Committee (Medicine), State of Washington, 1959-62; Visiting Lecturer, American Physiological Society, 1961-64; Member, Pacific Science Center's Visiting Scientist Program, Seattle, Washington, 1964-; Member, Manpower and Training Committee, National Library of Medicine, 1966-; Member, Executive Council, American Association for the History of Medicine, 1966-67; Secretary-Treasurer, American Association for the History of Medicine, 1967-.

Member, Sigma Xi, American Association of Anatomists, American Society of Zoologists, History of Science Society, American Association for the History of Medicine, Society for the Study of Growth and Development. Author, numerous articles and books.

ESTELLE BRODMAN

Librarian and Professor of Medical History, Washington University School of Medicine, St. Louis, Missouri, 1962 to date.

B. A., Cornell University, 1935; B.S., M.S., (Librarianship) Columbia University, 1936, 1943; Ph.D., Columbia University, 1953.

Career Summary:

Teaching: Columbia University, 1946-51; Catholic University, 1957; Keio University, Tokyo, 1962.

Librarianship: Cornell University Nursing School; Columbia University Medical Library; National Library of Medicine.

Publications:

Books: Bibliographical lists for medical libraries. 2d ed. 1949. Suppl. 1951  
Development of medical bibliography. 1954. 2d printing, 1956.

Numerous articles - 1966 & 1967 listed below

Why Continuing Education? D.C. Libraries, 37:51-54, Fall 1966

Machines in Medical Libraries. Med. & Biol. Illus., 16:238-242,  
October 1966

William Beaumont as a Physician. Wisconsin Med. Journ., 66:272-276,  
June 1967

Brodman, Estelle and Ohta, Mrs. Miwa. Bibliography: Current state  
and future trends. Part 2. Medicine. Library Trends, 15:896-908,  
April 1967.

## LOUISE DARLING

Librarian, Biomedical Library, University of California, Los Angeles, 1947 to date; Lecturer, Division of Medical History, UCLA School of Medicine, 1958 to date; Lecturer, UCLA School of Library Service, 1960 to date. A.B., University of California, Los Angeles, 1933; M.A., University of California, Berkeley, 1935; Certificate in Librarianship, University of California, Berkeley, 1936; General and Special Secondary Credential, University of California, Berkeley, 1935 and 1940.

### Career Summary:

Assistant Librarian, Giannini Foundation, University of California, Berkeley, California, 1936-39; Librarian, Acalanes Union High School, Lafayette, California, 1940-41; Science Reference Assistant, University of California, Los Angeles, California, 1941-44; Area Supervisor, Army Library Service, Hawaii and Philippines, 1944-47.

### Additional Professional Activities:

Medical Library Association: Board of Directors, 1961-65; President, 1963-64; Vice President, 1962-63; Chairman, Recruitment Committee, 1954-55; Chairman, Medical Schools Group, 1956-57; Chairman, Committee on International Cooperation, 1959-62; Chairman, MLA-NLM Liaison Advisory Committee, 1966-67. American Library Association: Vice Chairman (Chairman-Elect) of the Agriculture and Biological Sciences Subsection, 1967-68. Special Libraries Association: Chairman, Biological Sciences Division, Southern California Chapter, 1956-57. American Association for the History of Medicine: Council, 1961-64. Society for the History of Medical Sciences, Los Angeles: Vice President, 1961-62; Secretary, 1950 to 1960. Medical Library Group of Southern California: President, 1950-51; Secretary-Treasurer, 1949-50. Consultant to the Facultad de Ciencias Medicas, Universidad Nacional de Honduras, Tegucigalpa, Honduras, July 18-October 23, 1962, on Rockefeller Grant. PHS Advisory Committee for Scientific Publications, December 1, 1962-June 30, 1965. Director, USPHS Graduate Training Program in Medical Librarianship, Principal Investigator, Medical Library Resource Grant; Director, UCLA MEDLARS Search Station; Co-Principal Investigator, Brain Information Service.

Member, MLA, ALA, SLA, California Libraries Association, ADI, AAAS, AAHM, Society for the History of Medicine, Los Angeles and Medical Library Group of Southern California. Author, numerous articles and book reviews.

## RALPH T. ESTERQUEST

Librarian, Francis A. Countway Library of Medicine (Boston Medical Library - Harvard Medical Library), Boston, Massachusetts, 1965 to date. On leave September, 1967 to August, 1968 to serve as Director, International Relations Office, American Library Association, Washington, D.C. B.S., Northwestern University, 1933; B.S. in L.S., University of Illinois Library School, 1936; M.A., University of Illinois, 1940.

### Career Summary:

Order Assistant, University of Illinois Library, 1935-36; Cataloger and Reference Librarian, Northwestern University, 1936-37; Acquisitions Assistant, University of Illinois Library, 1938-40; Assistant Librarian, Institute for Advanced Study, Princeton, New Jersey, 1940-42; Sales Manager, Publishing Department, American Library Association, Chicago, Illinois, 1942-43; Director for Pacific Northwest Bibliographic Center, Seattle, Washington, 1944-46; Assistant Director of Libraries and Professor, University of Denver, Colorado, 1946-49; Director, Midwest Inter-Library Center, Chicago, Illinois, 1949-58; Librarian, Harvard Medical Library, Boston, 1958-65.

### Additional Professional Activities:

Has held various offices and committee assignments in the American Library Association, the Medical Library Association, and various state and local associations. Served on the Joint Committee, which compiled "Guidelines for Medical School Libraries," AAMC, 1965. Fulbright Senior Research Fellow (England), 1953-54. Consultant assignments include: Commissioner of Education, New York State; University of Ife, Nigeria; Trinity College, Dublin; University of Wisconsin; University of Miami; Atlanta University Center, Atlanta, Georgia; California State Library; Mississippi State Library; National Institutes of Health. Presently serving on Manpower and Training Committee of the National Library of Medicine. Formerly member Task Force No. 1, EDUCOM.



HERBERT H. FOCKLER

Training Grants Officer, Research and Training Division, Extramural Programs, National Library of Medicine. B.A., M.A., West Virginia University, 1947, 1948; M.S. in L.S., Catholic University, 1952; Graduate seminars at Oxford University, 1948; Harvard University, 1949; Princeton University, 1953; University of Maryland, 1967.

Career Summary:

Library Assistant, Harvard University, 1949; Acquisitions Assistant, Catholic University Library, 1951; Legislative Assistant, American Library Association, 1952; Supervisor, Serials and Documents Division, Princeton University Library, 1952-54; Supervisor, Government Documents Section, Library of Congress, 1956-58; Assistant Director, White House Conference, 1959-60; Research Program Administrator, National Institutes of Health, 1961-66.

Publications:

Editor of ten volumes of scientific papers, author of more than 100 reports and reviews.

Member, Special Libraries Association, American Documentation Institute, Medical Library Association, American Association for Advancement of Science, American Academy of Political and Social Science.

## MARIAN GOULD GALLAGHER

Marian Gould Gallagher is a native Washingtonian. She attended Whitman College for one year, and took degrees at the University of Washington: a B.A. under a combined degree program (in which credit was given toward the B.A. for the first year of Law School) in 1935, an LL.B. in 1937, and a B.A. in Librarianship in 1939.

From 1937 to 1939 Mrs. Gallagher was Assistant Law Librarian at the University of Washington, taking her librarianship work on a full-time basis while working half-time. From 1939 to 1944 she was Law Librarian and Assistant Professor of Law at the University of Utah; from 1944 until now she has been Law Librarian at the University of Washington, first with the rank of Assistant Professor of Law, then as Associate Professor, and in 1953 was promoted to Professor of Law. While in Law School she was elected to the Order of the Coif (the law honorary), and was a member of the Law Review Board.

Mrs. Gallagher is a member of the Washington and American Bar Associations. She is a member of the Association of American Library Schools and of the American Association of Law Libraries, and served as President of the latter organization in 1954/1955. She is a Charter Member of the Seattle North District Soroptimist Club.

Aside from the administrative duties connected with the University of Washington Law Library, Mrs. Gallagher teaches legal research and writing in the Law School, and is an adjunct member of the Faculty of the School of Librarianship. The University of Washington School of Librarianship has, so far as is known, the only curriculum which leads to a Master of Law Librarianship; Mrs. Gallagher teaches the four specialized courses required in that curriculum.

In February 1967 Mrs. Gallagher was appointed by President Johnson to serve on the National Advisory Commission on Libraries.

HENRY J. GARTLAND

Director, Library Service, Veterans Administration, Washington, D.C., 1954 to date.  
A.B., Boston College, 1936; M.Ed., Boston Teachers College, 1937; M.S.L.S.,  
Simmons, 1950.

Career Summary:

Reference Librarian, Boston Public Library, 1929-40; U.S. Army, 1941-46: Library  
Officer Ft. Lee, Virginia, 1942-44; Library Officer Army Service Forces, N.Y., 1944-  
45; Library Officer U.S. Army-Europe, Paris, 1945; Library Officer U.S. Army-Japan,  
Tokyo, 1946; U.S. Veterans Administration: Branch Librarian, Boston, Mass., 1946-  
48; Assistant Director, Library Service, Washington, D.C., 1949-54; Chief Army Library  
Program (Army Reserve), 1949-65.

Additional Professional Activities:

President, Association of Hospital and Institutional Libraries, ALA, 1951; Committee  
of Library Education, ALA, Member, Federal Library Committee; Chairman, Task  
Force on Physical Facilities, Federal Library Committee.

Member: MLA; SLA; Association of Military Surgeons of U.S. Author, articles in  
Library Journal, Hospitals and other similar publications.

## PAUL HOWARD

Executive Secretary: Federal Library Committee, The Library of Congress, Washington, D.C., 1966 to date. B.A., University of Oklahoma, 1927; B.S. in L.S., University of Illinois, 1930; M.A., University of Chicago, 1939.

### Career Summary:

Librarian, Panhandle A & M College, Goodwell, Oklahoma, 1927-28; Assistant Librarian, Missouri School of Mines, Rolla, Missouri, 1930-31; Librarian, Missouri School of Mines, 1931-39; Head, Industry and Science Department, Enoch Pratt Free Library, Baltimore, Maryland, 1939-41; Librarian, Gary Public Library, Gary, Indiana, 1941-45; Head, Library Services Branch, Office of War Information, 1943-44; Consultant, Office of Secretary of War (Army Library), 1944; Chief, Washington office of ALA, 1945-49; Librarian, U.S. Department of the Interior, 1949-1966.

### Additional Professional Activities:

Served as President or First Vice President of Missouri, Maryland, Indiana, and D.C. Library Associations. Has been active on various professional committees. Received in November 1966, Citation for Distinguished Service in recognition of outstanding service as the Librarian for the Department of the Interior.

Member, A.L.A., S.L.A., A.A.A.S., D.C.L.A.; Phi Kappa Phi, National City Christian Church, Abracadabra Club.

Author of numerous articles in professional journals.



DAVID A. KRONICK

Librarian, The University of Texas Medical School at San Antonio, Texas, 1965 to date. B.A., Adelbert College, Western Reserve University, 1939; B.S.L.S., School of Library Science, Western Reserve University, 1940; Ph.D., Graduate Library School, University of Chicago, 1956.

Career Summary:

Supply Officer, Army Medical Department, 1941-46; Librarian, Western Reserve University Medical School, 1946-49; Associate, Department of Sociology, University of Chicago, 1950-51; Assistant in Reference Department, National Library of Medicine, 1953-55; Librarian, Medical Library, University of Michigan, 1955-59; Director, Cleveland Medical Library, 1959-64; Chief, Reference Division, National Library of Medicine, 1964-65.

Additional Professional Activities:

Membership - Medical Library Association, American Library Association, American Documentation Institute, American Association for the Advancement of Science, American Association for the History of Science, American Bibliographical Society, Guild of the Bookworkers (American Institute of Graphic Arts).

Numerous articles and publications:

The origins and development of the scientific-technological periodical press, 1665-1790.  
Ph.D. Dissertation, University of Chicago, 1956.

A history of scientific and technical periodicals. New York, Scarecrow Press, 1962.

A program for the health sciences libraries. Cleveland, 1963.

Report to the Pan American Organization of a trip to Brazil, Uruguay, Argentina, Chile, Colombia, and Venezuela to investigate the feasibility of establishing a Latin American Regional Medical Library Center, April 17th through May 7th, 1965 (with Mortemei Taube). Washington, Pan American Health Organization, 1965 (Ref. RES 4/12).

and other items.

## IRVING LIEBERMAN

Director, School of Librarianship, University of Washington, Seattle, 1956 to date.  
B.S., New York University, 1935; B.S. (L.S.) Columbia University School of Library Service, 1939; M.A., Columbia University, 1950; Ed.D., Columbia University, 1955.

### Career Summary:

Library Assistant, Public Library, Newark, N.J., 1935-38; Branch Library Work, Public Library, Detroit, Mich., 1939-41; U.S. Army, 1942-46; Library Officer (U.S. Army) European Theatre of Operations 1944-46; Head, Extension Division Michigan State Library, 1946-48; Consulting position, State Prison of Southern Michigan, Jackson, Mich., 1948; Consulting position, ALA, 1949; Special Assistant, Superintendent of Central Service, Executive Assistant, Public Library, Brooklyn, New York, 1949-52; Research Associate in Charge of Audio-Visual Project, University of California (Berkeley), 1952-54; Associate in Library Service, Columbia University School of Library Service, 1954-56.

### Additional Professional Activities:

Chairman, General Policy and Executive Committees, PNLA Library Development Project, 1956-60; Principal Investigator, Contract between the University of Washington and U.S. Office of Education on Recruitment and Training of Staff and Support of Staff Dissemination Activities at Library 21 Exhibit, Seattle World's Fair, 1962; Advisory Director, Institute of Librarianship, University of Ibadan, Ibadan, Nigeria, 1963-64; Surveyor, Public Library, City of Lagos, Nigeria, 1963-64; Co-director, NDEA Institute for School Librarians: "The School Library Supervisor in the Modern Educational Program," contract between the University of Washington and U.S. Office of Education, Summer 1965.

Member, AAUP, ADI, ALA, PNLA, WLA, and WSASL. Author, numerous articles and monographs. Audio-Visual Instruction in Library Education, Columbia, 1955; Survey of the Lagos City Library, Nigeria, 1964.

HARRIS C. MC CLASKEY

Applicant for Ph.D. in Education (Higher Education), University of Washington, Seattle, 1967- . B.A., College of Wooster, Wooster, Ohio, 1953; Princeton Theological Seminary, 1953-1954; M.Lib., School of Librarianship, University of Washington, 1956.

Career Summary:

Sub-Professional Assistant, Seattle Public Library, 1955-56; Assistant Librarian, Renton Public Library, Renton, Wash., 1956-57; Head Librarian, Renton Public Library, 1957-1961; Library Consultant, Washington State Library, Olympia, Wash., 1962-65; Director, Institutional Library Services, Washington State Library, 1965-67.

Additional Professional Activities:

Library 21 Training, Seattle World's Fair, 1962; Director, Washington Library Film Circuit, 1962-65; Consultant on Institutional Library Services to Idaho, Illinois, Oregon, 1967; Keynote Speaker, University of Minnesota, School of Librarianship, Perrie Jones Institute on Institutional Library Services, Minneapolis, 1967; Chairman, Washington State Advisory Council to the Washington State Library Commission, Title IV, Parts A & B, P. L. 89-511; Chairman, AHIL Research Committee, 1965- ; Chairman, CSD Advisory Committee to the Demonstration of Library Services to Exceptional Children at the Public Library of Cincinnati & Hamilton County, Ohio, 1966- .

Member, ACA, ALA, CEA, CLA, MIA, NARC, NEA-CEC, PNLA, WLA, WSASL. Author, Articles; Editor, LIBRARY NEWS BULLETIN (Quarterly, Washington State Library) 1964-67; Editor, LETTER MAGAZINE, 1954-55. A Study Recommending Establishment of a Cooperative Library Program Between the Washington State Department of Institutions and the Washington State Library, Washington State Library, 1964.

GEORGE E. MC DONOUGH

Assistant Professor, School of Librarianship, University of Washington, 1967. A.B., University of California, Berkeley, 1949; M.A., Johns Hopkins University, 1950; M. Libr., University of Washington, 1963; currently doctoral student, University of Chicago.

Career Summary:

Junior Instructor in English Writing, Johns Hopkins University 1949-50; Associate Minister, First Unitarian Church of San Francisco 1951-52; Minister of the Unitarian Church of Eugene, Oregon, and the Community Church, Clackamas, Oregon, 1952-56; Instructor in Humanities and English, Lewis and Clark College and Portland State College, 1954-55; Associate Professor and Chairman of the Department of English, Cascade College, Portland, Oregon, 1956-62; Associate Professor and Chairman of the Department of Library Science, Seattle Pacific College, 1962-65; Visiting Assistant Professor of Library Science, Illinois Teachers College - Chicago; South, 1965-66; Assistant Professor and Director of Admissions and Student Affairs, Graduate School of Library and Information Services, University of Maryland, 1966-67.

Additional Professional Activities:

Member, Bogle Memorial Funds Committee, Library Education Division, American Library Association, 1966-69; AAUP, NCTE, ALA, WLA, WSLA.

Publications:

- "Lyric XIII," Saturday Review, September 29, 1941;  
Collected Poems. Berkeley, University of California Press, 1948;  
"Chapter and Verse," The Johns Hopkins Review, Spring 1950;  
The Farmington Plan: An Informative Study. Seattle, Seattle Pacific College Institute of Research, 1964;  
"For Mark My Son," Poetry Australia, June 1966;  
"Moral Education: Emile Durkheim and the Catholic Church," Catholic Educational Review, LXV, January 1967;  
"Access to Library Materials: The Wider Context," to be published in Catholic Library World, November 1967.



GERALD J. OPPENHEIMER

Head, Health Sciences Library, University of Washington, Seattle, 1963 to date. B.A. University of Washington, 1946; M.A. University of Washington, 1947; M.A. (L.S.) Columbia University, 1953.

Career Summary:

Junior Librarian, Technology Department, Seattle Public Library, 1953-55; Fisheries-Oceanography Librarian, University of Washington, 1955-60; Manager, Information Services, Boeing Scientific Research Laboratories, 1960-63.

Additional Professional Activities:

Chairman, Library Committee, The Boeing Company, 1960-63; Special Assistant for Planning to the Chairman of the Board of Health Sciences, University of Washington, 1966; Visiting Instructor, Department of Philosophy, University of Washington, 1950; Visiting Assistant Professor, School of Librarianship, University of Washington, 1960; Chairman, Pacific Northwest Regional Group of the Medical Library Association, 1965-66.

Member, Association for Symbolic Logic, American Documentation Institute, Special Libraries Association, Medical Library Association.

Publications:

- "Reference Sources for Marine Mammalogy," Special Scientific Report--Fisheries, No. 361; 1960.
- "Coordination Through Cooperation--The Boeing Approach," In: Special Libraries, 53: 476-478; 1962
- "Portrait of the Anatomist Alexander Thomson," (with M. J. Rheault, M.D. and L. M. Nyhus, M.D.) In: Surgery, Gynecology and Obstetrics, 121: 601-606; 1965.
- [Ed.] Regional Medical Library Service in the Pacific Northwest, Proceedings of a Conference at the University of Washington, May 12-13, 1966; 1967.

RICHARD H. ORR

Director, Institute for Advancement of Medical Communication, Philadelphia, Pennsylvania, 1962 to date. B.S., University of Chicago, 1948; M.D. University of Southern California, 1950.

Career Summary:

U.S. Navy, 1942-45; U.S. Naval War College, 1945; Rotating internship and residency in internal medicine--Southern Pacific Hospital, San Francisco, 1950-53; Chief Medical Resident, 1952-53; Research Fellow, University of California Medical Center, Metabolic Unit, San Francisco, 1953-55; Medical Director, Grune & Stratton, Inc. (medical publishers), 1955-57; Executive Director, Institute for Advancement of Medical Communication, 1958-62.

Additional Professional Activities:

Assistant Editor, Metabolism, 1955-62; Co-Editor, Journal of the Association for Psychiatric Treatment of Offenders, 1956-60; Associate Editor, New York State Journal of Medicine, 1959- ; Consulting Editor, Modern Medical Monographs, Modern Surgical Monographs, Modern Monographs in Industrial Medicine, 1957-59; Board of Directors, Association for Psychiatric Treatment of Offenders, 1957-60; Program Chairman, Conference of Biological Editors, 1960; President, American Medical Writers' Association, 1961-62; Chairman, Board of Trustees, 1963; Editor, Methods of Information in Medicine, (formerly Medical Documentation), 1961- ; Board of Directors, American Science Film Association, 1963-65; Research Associate, University City Science Center, Philadelphia, 1965- ; Honorary Director, Council on Medical Television, 1963- .

Societies:

American Association for the Advancement of Science (Fellow), American Documentation Institute, American Medical Writers' Association (Fellow), American Physiological Society, Association of American Medical Colleges, Council of Biological Editors, Endocrine Society, Society for Technical Writers and Publishers (Senior Member), National Society for the Study of Communication.

## VERN M. PINGS

Professor, Wayne State University, School of Medicine, 1966 to date - Medical Librarian, Wayne State University, School of Medicine Library, 1961 to date. Ph.D. University of Chicago, 1944-46; B.A. University of Wisconsin, 1946-47; M.A. Columbia University, 1948-52; M.A.L.S., University of Wisconsin, 1954-55; Ph.D., University of Wisconsin, 1956-58.

### Career Summary:

Chicago Health Department, Chicago, 1944-46; Science Instructor, Englewood Hospital School of Nursing, Chicago, 1947-48; Environmental Sanitation Officer, American Friends Service Committee United Nations Relief for Palestine Refugees, Gaza, Palestine, 1949-50; Works Office, United Nations Relief and Works Agency, Beirut, Lebanon, 1950-51; Director, University Farms, American University of Beirut, School of Agriculture, Beirut, Lebanon, 1952-54; Ass't Engineering Librarian, University of Wisconsin, College of Engineering, 1955-58; Librarian, Ohio Northern University, Ada, Ohio, 1959; Associate Professor, University of Denver, School of Librarianship, 1960.

### Additional Professional Activities:

Visiting Lecturer, Kent State University, Kent, Ohio, 1962; Consultant, National Academy of Sciences, Washington, D.C., 1963; Project Director, Indexing Project, American Nurses' Foundation, New York, 1964; Member Executive Council, Midwest Regional Group, Medical Library Association, 1964-65; Editorial Advisory Committee, International Nursing Index, New York, 1965- ; Member, Committee on Surveys and Statistics, Medical Library Association, 1965- ; Member Project on Medical Library Problems, American Association of Medical Colleges, 1966- ; Member Facilities and Resources Committee, U.S. Public Health Service, National Library of Medicine, 1966- ; Lecturer, Department of Library Science, University of Michigan, Ann Arbor, Michigan, 1966- ; Research Associate, Institute for Advancement of Medical Communication, Philadelphia, Pennsylvania, 1966- ; Chairman, Committee on Library Service for Hospitals, American Hospital Association, Chicago, 1966-67.

Numerous publications and articles. (Some recent imprints listed below):

- Problems of providing access to the scholarly record to postgraduate medical students in metropolitan Detroit. Wayne State University School of Medicine Library and Biomedical Information Service Center. Report No. 27. Feb. 1967.
- An evaluation of nine hospital health science libraries' text and monograph collections, Wayne State University School of Medicine Library and Biomedical Information Service Center. Report No. 28. Feb. 1967.
- Library service for health care. Wayne State University School of Medicine Library and Biomedical Information Service Center. Report No. 34. April 1967.
- Availability of hospital health science library service to Wayne County Medical Society physicians, Wayne State University School of Medicine Library and Biomedical Information Service Center. Report No. 36. May 1967.

## ALAN REES

Associate Professor, Library Science; Assistant Director for Research, Center for Documentation and Communication Research, 1964 to present. B.A., University of London, London, England, 1950; B.Litt., Oxford University, Oxford, England, 1952; Ohio State University, Columbus, Ohio, 1952-55; M.S.L.S., Western Reserve University, Cleveland, Ohio, 1956.

### Career Summary:

Staff member, Center for Documentation and Communication Research, 1956-64; Project Manager of the American Society for Metals abstracting and indexing project at Western Reserve and responsible for the operations of the Metals Documentation Service, 1959-62.

### Additional Professional Activities:

Involved in a number of research projects relating to indexing languages, search strategy, selective dissemination systems and the design, testing and evaluation of information retrieval systems. Recently appointed as a special consultant to the Public Health Service as a member of the NLM Manpower and Training Committee. Secretary-Treasurer of the Association of American Library Schools.

Member, American Documentaion Institute: serves on the ADI Council; Chairman of the Education Committee, past Chairman of the Cleveland Chapter; Member, Special Libraries Association; International Association of Documentalists, Institute of Information Scientists of Great Britain; Medical Library Association. Author of some fifty papers and reports.



WILLIAM O. ROBERTSON

Associate Dean, School of Medicine, and Associate Professor, Department of Pediatrics, School of Medicine, University of Washington, Seattle, Washington; B.A., University of Rochester, 1946; M.D., University of Rochester, 1949.

Career Summary:

Faculty member: Yale University (1955-56)  
Ohio State University (1956-63)  
University of Washington (1963 to present)

Assistant Dean: Ohio State University College of Medicine (1962-63)  
University of Washington School of Medicine (1963-65)

Associate Dean: University of Washington School of Medicine (1965 to present)

Medical Director: University Hospital, Seattle, Washington (1963-67)

Additional Professional Activities:

Member of American Medical Writers Association  
Member of Editorial Board, Amer. Jour. of Diseases of Children

## DONAL R. SPARKMAN

Director, Regional Medical Program for Heart Disease, Cancer, and Stroke, and Associate Professor, University of Washington School of Medicine, 1966 to present.

B.S., University of Washington, 1926-30, M.D., University of Pennsylvania School of Medicine, 1930-34; Internship, University of Pennsylvania Hospital, 1934-37; Fellow in Medicine, University of Pennsylvania Hospital, 1936-37 (6 mos.); Medical Staff, Biggs Memorial Hospital, Ithaca, New York, 1937-38; Chief Resident in Diseases of Chest, Bellevue Hospital, New York, 1938-39; Chief Resident in Medicine, Bellevue Hospital, New York, 1939-40; Chief Resident, Cardiology, House of Good Samaritan, Boston, 1940-41.

### Career Summary:

Instructor in Medicine, Columbia University School of Medicine, 1938-40; Instructor in Medicine, Harvard University School of Medicine, 1940-41; In private practice in Seattle, Internal Medicine and Cardiology, 1944-60; Clinical Instructor, University of Washington School of Medicine, 1947; Clinical Assistant Professor, University of Washington School of Medicine, 1952; Associate Clinical Professor, University of Washington School of Medicine, 1954; Clinical Professor, University of Washington School of Medicine, 1959; Medical Director, Division of Vocational Rehabilitation, Olympia, 1960-66.

### Additional Professional Activities:

Consultant in Cardiology, Firland Sanatorium, 1955-60; Consultant in Chest Diseases, USPHS Hospital, Seattle, 1958-60.

Member: Fellow, American College of Physicians; North Pacific Society of Internal Medicine; Northwest Society for Clinical Research; Seattle Academy of Internal Medicine; American Medical Association; Washington State Medical Society; Thurston-Mason County Medical Society; Fellow American Heart Association Council in Clinical Cardiology, 1964; Diplomate, American Board of Internal Medicine, 1947; Subspecialty Cardiology Board, 1948; Alpha Omega Alpha.

### Numerous publications and articles:

- Belknap, Elston, Sparkman, Donal R., et al. Work and the Heart. Transactions of the First Wisconsin Conference on Work and the Heart. Published by Paul B. Hoeber, Inc., Medical Book Dept. of Harper & Brothers, New York. 1959.
- Sparkman, Donal R. Role of the Private Physician in the Care of the Ambulatory Cardiac Patient. Conference on Advances in the Management of Chronic Heart Disease, published by the New York Heart Association. 70-79. January 1964. Republished in Journal of Chronic Diseases, Sept. 1965.
- Sparkman, Donal R. Medical Knowledge of the Ailment (From National Stroke Congress, October 1964) Rehabilitation Record 6:1. 36-37. January-February 1965.
- Sparkman, Donal R. and Levenson, Robert M. Employability After Cardiac Rehabilitation. Northwest Medicine 64:4. 269-272. April 1965.

## CHARLES R. STROTHER

Director, Mental Retardation and Child Development Center, University of Washington, 1964 to date. Professor of Psychology and Professor of Clinical Psychology in Medicine, University of Washington, 1947 to date. B.A., University of Washington, 1929; M.A., University of Washington, 1932; Ph.D., University of Iowa, 1935.

### Career Summary:

Academic appointments: Instructor in Speech, University of Washington, 1929-34; Assistant Professor of Speech Pathology, University of Washington, 1935-39; Visiting Professor of Psychology, Penn. State, Summer, 1939; Associate Professor of Clinical Psychology and Speech Pathology, University of Iowa, 1939-47; Visiting Professor of Speech Pathology, Emory University Medical School, Summer, 1945; Visiting Professor of Special Education, University of Oregon, Summer, 1953.

Clinical and administrative appointments: Director, Speech Clinic, University of Washington, 1935-39; Director, Mobile Diagnostic Clinics, Washington State Dept. of Public Instruction, 1937-39; Director, Iowa Psychological Clinic, 1939-47; Chief Psychologist, University of Iowa Hospitals, 1940-47; Psychologist, Iowa Crippled Children's Services, 1941-47; Director, Pilot School for Brain-Injured Children, University of Washington, 1961-65; Acting Director, Child Development Laboratories, University of Washington, 1965-67.

### Additional Professional Activities:

Consulting or attending: Jamestown School for Crippled Children; Children's Orthopedic Hospital; Madigan Army Hospital; King County Hospital; VA General Medicine & Surgical Hospitals and Neuropsychiatric Hospitals; Washington State Cerebral Palsy Center; Spastic Clinic and Preschool, Seattle; University Hospital.

Public Service: Member, National Advisory Mental Health Council; Consultant, National Institute of Mental Health; Consultant, U.S. Office of Education; Professional Advisory Board, National Society for Crippled Children; Research Advisory Board, United Cerebral Palsy; Consultant, American Foundation for the Blind; Consultant, National Institute of Labor Education; Chairman, Council on Mental Health Research and Training, Western Interstate Commission for Higher Education; Chairman, State Advisory Council on Mental Health and Mental Retardation.

Memberships: Fellow, American Psychological Association; Fellow (formerly), American Speech and Hearing Association; Diplomate, American Board of Examiners in Professional Psychology; Member, Western Psychological Association; Member, Washington State Psychological Association; Member, National Council on Psychological Aspects of Physical Disability; Sigma Xi; Phi Beta Kappa.

Articles in: Psychological Monographs, Journal of Speech Disorders, American Journal of Psychiatry, Pediatrics, Journal of Abnormal and Social Psychology. Foundations of Speech (co-author), New York, 1945; Psychology and Mental Health (editor), American Psychological Assn., 1957.

## HELEN YAST

Librarian, American Hospital Association, Chicago, 1954 to date. A.B., Indiana University, 1937; M.A., Rosary College, 1967.

### Career Summary:

Teacher-Librarian, Rolling Prairie High School, Rolling Prairie, Ind., 1938-41; Library assistant, U.S. Public Health Service Library, Bethesda, Md., 1942; Librarian, Rocky Mountain Laboratory, Hamilton, Montana, 1942-44; Librarian, U.S. Naval Hospital, New Orleans, La., 1944-45; Patients' Librarian, Hines Hospital, Hines, Ill., 1946; Librarian, Veterans Administration Hospital, Fort Benjamin Harrison, Ind., 1946-47; Assistant Librarian, American Hospital Association, 1947-53.

### Major Professional Activities:

American Library Association: Council, 1967-1971; President, Association of Hospital and Institution Libraries, 1959-60; AHL Exceptional Service Award, 1967; Catholic Library Association: Chairman, Hospital Libraries Section, 1963-64; Medical Library Association: Chairman, Midwest Regional Group, 1957-58; Ad Hoc Committee on Future of MLA, 1965-67; Nominating Committee, 1967-69.

Member, AIA, CLA, MLA, SLA. Author, articles in hospital and library journals.



APPENDIX D

A SELECTED BIBLIOGRAPHY  
for the  
CONFERENCE ON EDUCATION  
for  
HEALTH SCIENCES LIBRARIANSHIP

- Annan, Gertrude L. "Library Technicians: Need, Training, Potential," Bulletin of the Medical Library Association, LII (January, 1964), 72-80.
- Bloomquist, Harold and Kinney, Margaret M. "Continuing Education of Medical Librarians; Continuing Education in the Professions," Bulletin of the Medical Library Association, LI (July, 1963), 357-67.
- Brodman, Estelle. "Continuing Education for Medical Librarianship; a Symposium. Internships as Continuing Education," Bulletin of the Medical Library Association, XLVIII (October, 1960), 408-412.
- Brodman, Estelle. "Continuing Education of Medical Librarians. Introduction." Bulletin of the Medical Library Association, LI (July, 1963), 354-56.
- Darling, Louise. "Development of Training Programs in American Medical Libraries," Bulletin of the Medical Library Association, LI (July, 1963), 339-53.
- Darling, Louise. "On Education for Biomedical Librarianship," Bulletin of the Medical Library Association, LII (October, 1964), 701-705.
- Denison, Barbara et al. (ed.) Proceedings of a Conference on Regional Medical Library Services. Cleveland, Ohio: Western Reserve University, 1967.
- Felter, Jaqueline W. "Continuing Education for Medical Librarianship; a Symposium. Informal Study," Bulletin of the Medical Library Association, XLVIII (October, 1960), 420-23.
- "The Health Sciences Library--Its Role in Education for the Health Professions," (Library Study Committee of the Association of American Medical Colleges--Report to the National Library of Medicine.) Journal of Medical Education, XLII (August, 1967), Part 2.
- Kronick, David A. "Continuing Education for Medical Librarianship; a Symposium. Refresher Courses," Bulletin of the Medical Library Association, XLVIII (October, 1960), 415-19.
- Libbey, Miriam Hawkins. "MLA Certification: The Certification Program and Education for Medical Librarianship," Bulletin of the Medical Library Association, LV (January, 1967), 5-8.
- Medical Library Association. "Code for Training and Certification of Medical Librarians," Bulletin of the Medical Library Association, LII (October, 1964), 784-89.
- Meyerhoff, Erich. "Continuing Education of Medical Librarians, Evaluation and Suggestions," Bulletin of the Medical Library Association, LI (July, 1963), 376-83.

Oppenheimer, Gerald J. (ed.) Regional Medical Library Service in the Pacific Northwest. Seattle, Washington: University of Washington, 1967.

Postell, William D. "Continuing Education for Medical Librarianship; a Symposium. Some Practical Thoughts on an Internship Program," Bulletin of the Medical Library Association, XLVIII (October, 1960), 413-14.

Proctor, Vilma. "MLA Certification; Its Present Problems and Future Development," Bulletin of the Medical Library Association, LV (January, 1967), 9-12.

Toward Improved Learning. Atlanta, Ga.: Public Health Service Audiovisual Facility, 1967.

Troxel, Wilma. "Continuing Education for Medical Librarianship; a Symposium. Formal University Courses," Bulletin of the Medical Library Association, XLVIII (October, 1960), 404-407.

Withrow, Betty A. "Continuing Education of Medical Librarians," Bulletin of the Medical Library Association, LI (July, 1963), 368-75.

Wooten, Elizabeth B. and Easterling, W. Sidney. "A Pilot Project in Training for Mental Health Librarianship," Bulletin of the Medical Library Association, LIII (April, 1965), 239-44.

Yast, Helen. "...And Gladly Teach: the American Hospital Association's Experience in Conducting Institutes on Hospital Librarianship," Bulletin of the Medical Library Association, LII (January, 1964), 81-89.