

R E P O R T R E S U M E S

ED 015 621

EF 000 471

GUIDE FOR THE EVALUATION OF SCHOOL FACILITIES.

BY- RESNICK, JEROME J. AND OTHERS

CALIFORNIA ASSN. OF PUBLIC SCH. BUSINESS OFFICIALS

PUB DATE APR 66

EDRS PRICE MF-\$0.50 HC-\$2.56 62P.

DESCRIPTORS- \*FACILITY GUIDELINES, \*ENVIRONMENTAL INFLUENCES, \*EVALUATION METHODS, \*PHYSICAL ENVIRONMENT, \*SCHOOL CONSTRUCTION, ACOUSTICAL ENVIRONMENT, AUDIOVISUAL AIDS, EQUIPMENT, HEATING, MAINTENANCE, SAFETY, SCHOOL BUILDINGS, SCHOOL PLANNING, SPATIAL RELATIONSHIP, VISUAL ENVIRONMENT.

THE SCHOOL EVALUATION GUIDE IS DESIGNED TO PROVIDE WORKABLE CRITERIA FOR APPRAISAL OF THE PHYSICAL CHARACTERISTICS OF EXISTING SCHOOL PLANTS. INFORMATION OBTAINED FROM THE GUIDE CAN BE USED FOR THE PURPOSE OF SEEKING OUT UNSATISFACTORY BUILDING FEATURES AND TO STIMULATE IMPROVEMENTS IN FUTURE SCHOOL CONSTRUCTION. WITH THIS EVALUATION PROCEDURE, SCHOOL ADMINISTRATORS AND ARCHITECTS CAN DETERMINE DEFICIENT CHARACTERISTICS IN A SCHOOL AND THE STEPS TO BE TAKEN IN CORRECTING THEM. SECTION PROFILES HAVE BEEN INCLUDED IN THIS CRITERIA FOR THE SITE--SPATIAL, VISUAL, THERMAL, SONIC, AESTHETIC, AUDIO-VISUAL, EQUIPMENT, SAFETY, AND MAINTENANCE FACTORS. THE SECTION PROFILES HAVE BEEN DEVELOPED TO PERMIT A MORE DETAILED EVALUATION FOR EACH OF THE FACTORS THAT ARE TREATED UNDER THE SAME FORMAT CONTAINING A BRIEF DESCRIPTIVE PARAGRAPH, A SET OF QUESTIONS RELATIVE TO SPECIALIZED ASPECTS OF THE FACTOR, AND AN EVALUATION PROFILE FORM. THE FINAL SECTION OF THE GUIDE IS A SERIES OF QUESTIONNAIRES TO BE SUBMITTED TO GROUPS OF TEACHERS, PRINCIPALS, STUDENTS, AND DISTRICT ADMINISTRATORS. THESE QUESTIONNAIRES SUPPLEMENT DATA GATHERED ON SONIC, THERMAL, AND VISUAL FACTORS. THIS EVALUATION GUIDE REPRESENTS THE EFFORT OF SCHOOL PLANNERS, ADMINISTRATORS, ARCHITECTS, AND ENGINEERS WHO HAVE CONTRIBUTED THEIR TIME TO THE CAUSE OF BETTER SCHOOL PLANNING. IT IS IN EXPERIMENTAL FORM AND THROUGH PERIODIC USE, A FINAL GUIDE WILL BE DEVELOPED. (RK)

ED015621

**GUIDE  
FOR  
EVALUATION OF SCHOOL FACILITIES**

**CALIFORNIA ASSOCIATION OF PUBLIC SCHOOL  
BUSINESS OFFICIALS**

**Presented by: Southern Section  
Building Committee  
April 1966**

EF000471

ERIC

**U.S. DEPARTMENT OF HEALTH, EDUCATION & WELFARE  
OFFICE OF EDUCATION**

**THIS DOCUMENT HAS BEEN REPRODUCED EXACTLY AS RECEIVED FROM THE  
PERSON OR ORGANIZATION ORIGINATING IT. POINTS OF VIEW OR OPINIONS  
STATED DO NOT NECESSARILY REPRESENT OFFICIAL OFFICE OF EDUCATION  
POSITION OR POLICY.**

**GUIDE FOR THE EVALUATION OF SCHOOL FACILITIES**

**Presented by the Southern Section  
Building Committee**

**California Association Public  
School Business Officials**

**April, 1966**

## TABLE OF CONTENTS

	Page
Preface	1
Acknowledgments	2
How to Use the Guide for the Evaluation of School Facilities	3
Summary Evaluation Profile	4
School Facilities Design Factors	
A. Site	A-1
B. Spatial	B-1
C. Visual	C-1
D. Thermal	D-1
E. Sonic	E-1
F. Aesthetics	F-1
G. Audio-Visual	G-1
H. Equipment	H-1
I. Safety	I-1
J. Maintenance	J-1
Supplementary Evaluation Questionnaires	
A. Visual	K-1
B. Thermal	L-1
C. Sonic	M-1

## PREFACE

The problem of determining the kind of school to be built is a matter of major importance to architects, engineers, school planners, administrators and teachers. All of the specialists involved in planning a school are constantly looking for better answers to this problem.

While a great deal of time is devoted to the planning of a school, little or no time is devoted to the problem of determining how well the completed school building will fulfill its purpose.

For a number of years school planners have attempted to develop a procedure for evaluating schools in order to measure the degree of excellence of the school plant.

One of the primary factors that had to be considered in attempting to evaluate a school was the difficulty of measuring schools in relation to a fixed scale or standard.

Differences in the size, types of school buildings, equipment, environment, financial support, abilities of students, needs of communities, and other factors make such a standardization impractical.

While being aware of the problems of evaluation based on fixed standards, a procedure had to be developed that was flexible to the extent of permitting self-evaluation by administrators, architects, engineers, teachers and staff. The following information, obtained from a school plant evaluation, can be used to eliminate unsatisfactory building features and stimulate improvements in future school facilities:

1. Identification of facilities where improvements and changes should be made.
2. Determining how we can improve on what has been done.
3. Identifying unsatisfactory features in the new school plant.
4. Finding out what we would do differently if we had to build the same school all over again.

It is a matter of primary importance for a new school building to be evaluated after a period of use in order to determine features which should be modified or eliminated and those which should be repeated in future buildings.

This evaluation guide represents the untiring effort of school planners, administrators, architects, and engineers who have contributed their time to the cause of better school planning.

Although this guide is in experimental form, it is our hope that, through periodic use, a final guide will be developed.

JERRY RESNICK  
Chairman Southern Section  
Building Committee

A C K N O W L E D G M E N T S

SOUTHERN SECTION BUILDING COMMITTEE

Jerome J. Resnick, Chairman - Anaheim Union High School District  
Richard S. Hollingshead, Vice Chairman - Ocean View School District  
Robert J. Lueck, Secretary - Lennox School District  
Kyle E. Berkey - Santa Ana Unified and Junior College District  
Wallace S. Brandhofer - Lowell Joint Union School District  
Aubrey W. Calvert - Bureau of School Planning  
Marion W. Day - Montebello Unified School District  
Walter J. Ferree - Victorville School District  
Ed Gustafson - Bureau of School Planning  
Ben Harder - State Division of Architecture  
William K. Hutchason - Architect A.I.A.  
Harry Saunders - Los Angeles City School District  
Leon Miller - Pomona Unified School District  
Donald Nack - Mechanical Engineer  
Harry C. Schwilke - Bureau of School Planning  
Earl V. Thomson - Westside Union School District  
Arthur Millier - Architect A.I.A.  
Foster K. Sampson - Electrical Engineer  
Russell P. Randell - Electrical Engineer  
Bill Jones - Electrical Engineer  
Sam Stathis - Mechanical Engineer  
Dallas Lauerdale - Audio Visual Coordinator

## HOW TO USE THE GUIDE FOR THE EVALUATION OF SCHOOL FACILITIES

The school evaluation guide is designed to provide workable criteria for appraisal of the physical characteristics of existing school plants. Information obtained from the evaluation guide can be used for the purpose of seeking out unsatisfactory building features and to stimulate improvements in future school construction.

With this evaluation procedure, school administrators and architects can determine characteristics in a school which are deficient and the steps to be taken in correcting such deficiencies.

Section profiles have been included in this criteria for the site, spatial, visual, thermal, sonic, aesthetic, audio-visual, equipment, safety, and maintenance factors. The section profiles have been developed to permit a more detailed evaluation for each of the factors.

### Section Profiles

- A. Read each statement carefully and determine how well the school plant in question meets the stated objective. Place the appropriate score according to item B on the blank line. The seven items should be used in scoring all statements. Each statement has a possible maximum score of five points. Each square should be rated on a scale ranging from 5 to 0.
- B. Score
- 5 - Excellent - for exceptionally fine conditions
  - 4 - Very Good - for outstanding conditions
  - 3 - Good - for average and acceptable conditions
  - 2 - Fair - for moderate or limited conditions
  - 1 - Poor - for conditions lacking and functioning poorly
  - 0 - Deficient - does not meet any of the conditions
  - X - Not Applicable - conditions missing and are not needed or applicable
- C. The actual score for each section is obtained by dividing the total score by the number of statements answered. Statements that are not applicable should not be considered in the overall rating.
- D. When the actual score of each section has been determined, place a mark on the evaluation profile according to the score indicated. For example, a score of four points would be marked on the fourth circle from the center on the profile.
- E. When each of the statements in all categories of the section has been considered, the section profile should be marked to correspond with the section score. The total score for the section should be shown on the Summary Evaluation Profile on page 4.

### Summary Evaluation Profile

When each School Facility Design Factor profile has been scored on the Summary Profile, connect each point with a continuous line to form an evaluation configuration for the school. The greater the area enclosed by the continuous line, the higher the overall rating.



# SUMMARY EVALUATION PROFILE

SCHOOL

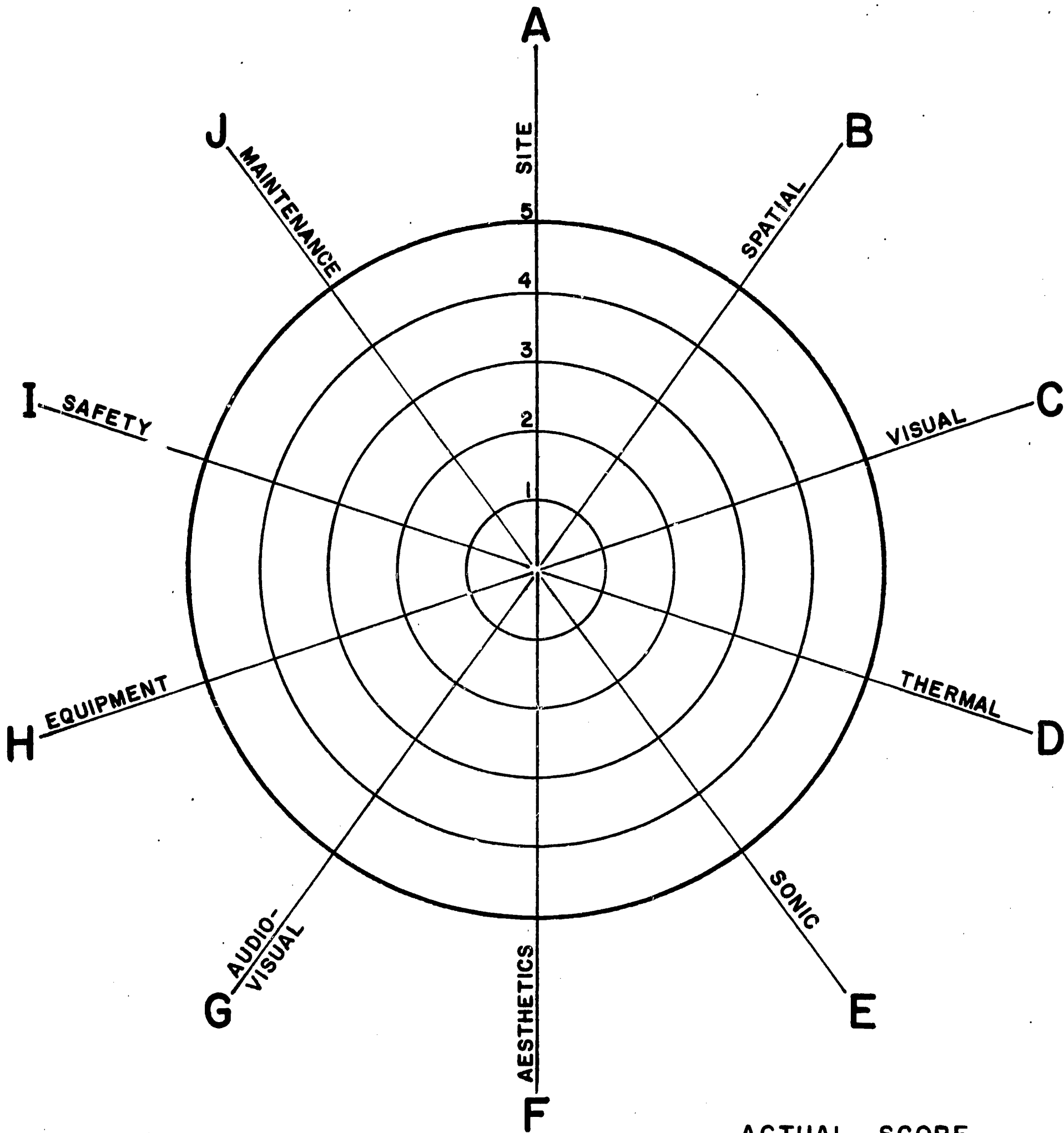

ACTUAL SCORE



## A. SITE DESIGN FACTOR

### SITE FACTORS

A school site serves many educational uses and is a functional part of the school plant. A good site should include areas for physical education, parking, loading and unloading of pupils, drives, walks, recreation and supplementary space such as might be anticipated. The building should be arranged on the site so that its best elevation faces the most used approach. Driveways should not encircle the building. Intersection drives and walks should be avoided. School accessibility must be measured in terms of the time it takes for students to get from home to school and the quality of the route environment. The site must be sufficiently elevated to avoid drainage from surrounding areas and adequately pitched to shed its own surface water quickly. Site costs must include both purchase price and development costs for realistic evaluation. The school site should fit the fabric of the comprehensive general master plan of the city as it relates to major utilities, streets, and areas of prime development and growth.

### SITE AREA

- \_\_\_\_\_ 1. Space sufficient for present and future classroom buildings.
- \_\_\_\_\_ 2. Space sufficient for auto parking on site for ultimate enrollment.
- \_\_\_\_\_ 3. Space sufficient for storage, maintenance supplies, and vehicles.
- \_\_\_\_\_ 4. Shape of site is rectangular, with length to width ratio of 5 to 3 minimum.
- \_\_\_\_\_ 5. Space sufficient to provide adequate, safe areas for outdoor physical education, recreation, and student assembly activities.

### SITE ENVIRONMENT

- \_\_\_\_\_ 1. Site well related to student residences, parks, recreation centers, other schools, and school service centers.
- \_\_\_\_\_ 2. Site free of air pollution caused by adjacent freeways, railways, and industries.
- \_\_\_\_\_ 3. Site free of high level disturbing sounds created by freeways, aircraft flight patterns, railways, and industries.
- \_\_\_\_\_ 4. Site permits safe, adequate ingress and egress for both pedestrian and vehicular traffic.
- \_\_\_\_\_ 5. Site was selected on the basis of utilization rather than on basis of the least dollar cost.

#### SITE DEVELOPMENT

- \_\_\_\_\_ 1. Site developed with two or less different grade elevations, and landscaped to provide aesthetic and utilitarian values.
- \_\_\_\_\_ 2. Site drainage is channeled under sidewalks, away from buildings, and from parking areas. Turfed areas to have a minimum of 2% slope for drainage.
- \_\_\_\_\_ 3. Site is free from hazards such as high tension wires, flooding, and earthslides.
- \_\_\_\_\_ 4. Site topography required a minimum of excavation or fill.
- \_\_\_\_\_ 5. Site soil and subsoil readily support building loads with normal footings and fertility supports normal landscaping.

#### BUILDING ORIENTATION

- \_\_\_\_\_ 1. Buildings have access on the most used approach.
- \_\_\_\_\_ 2. Buildings shaped and located for appropriate future expansion.
- \_\_\_\_\_ 3. Building lay-out takes advantage of existing natural elements and views.
- \_\_\_\_\_ 4. Buildings are so spaced to provide smooth uncongested student traffic flow.

# SITE EVALUATION PROFILE

SCHOOL \_\_\_\_\_

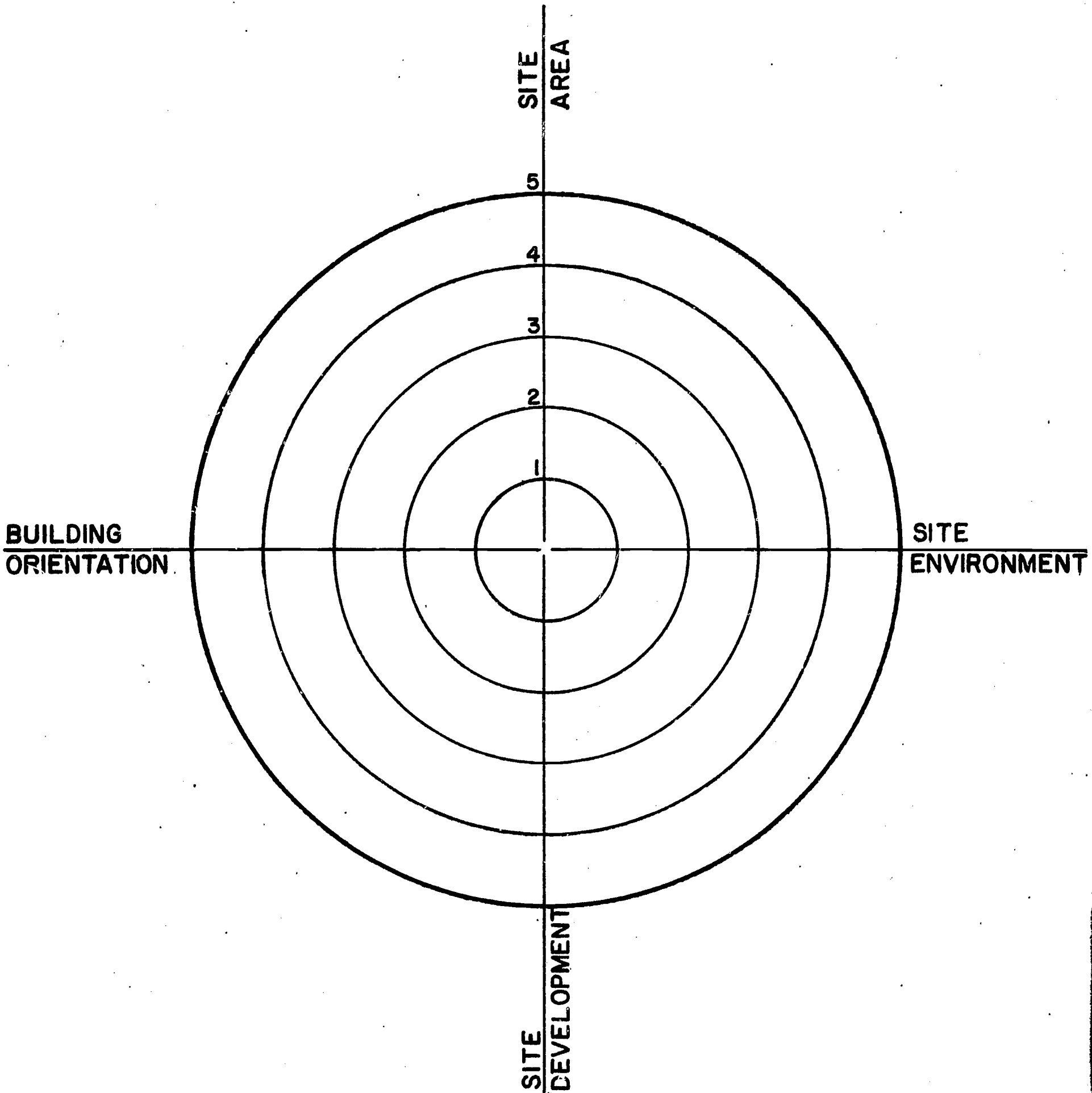

ACTUAL SCORE

## B. SPATIAL DESIGN FACTOR

This factor pertains to the amounts of space, types of space, and the relationships of space within a school plant. The school plant not only includes the buildings, but also the outdoor facilities which are necessary in a complete educational program.

The amount and dimensions of floor area in a school building are determined by the curricular emphasis of the educational program. The dimensions of the floor area are determined by the varying kinds of activities engaged in by both the pupils and teachers.

The outdoor space of a school facility also has dimension both laterally and horizontally as it relates to the educational activities to be performed. Space requirements necessary for accessibility to and from the school plant by pupils, teachers, patrons, and services are also space considerations pertaining to the outdoors.

Evaluation of spaces above required in a coordinated plan is based upon value judgments derived from priority items developed within the school district.

### Adequacy

- \_\_\_\_\_ 1. The school plant provides space necessary for the efficient accommodation of all phases of the instructional and community program.
- \_\_\_\_\_ 2. The design reflects the use of a space adequacy survey or similar technique to clearly define space requirements and program.
- \_\_\_\_\_ 3. The amount of space in each of the various units (net area) is sufficient to allow for convenient, efficient performance of all of the activities which are intended to be housed.
- \_\_\_\_\_ 4. Space has been provided for large and small group instruction as well as individual instruction.
- \_\_\_\_\_ 5. Space has been provided for staff requirements for storage, work, study, dining, conference, and planning activities.
- \_\_\_\_\_ 6. Storage facilities, chalkboards, tackboards, and utility services are adequate for the pupil and teacher activities and are located conveniently.
- \_\_\_\_\_ 7. Utility services are of ample capacity to permit efficient use of teaching devices.

## Shape

- \_\_\_\_\_ 1. Building shapes implement the functional use of space and contribute to the use of the space for educational activities, and are a direct outcome of the planning process.
- \_\_\_\_\_ 2. Building cubage has been held to a minimum commensurate with activities and other design requirements.
- \_\_\_\_\_ 3. The general layout and arrangement of classrooms provide adaptation of instruction to a variety of learning activities; there are no lost unusable areas due to design restrictions.
- \_\_\_\_\_ 4. The design permits the instructor to move freely between student stations in the supervision of the individual's work.

## Flexibility

- \_\_\_\_\_ 1. The design concept provides for flexibility, expansibility, and adaptability for multiple use of spaces without structural, mechanical, or utility alterations.
- \_\_\_\_\_ 2. Buildings are located on the site to permit future expansion needs. Utility services have been located and sized to accommodate the ultimate development.
- \_\_\_\_\_ 3. The structural system permits interchangeable use internally as the instructional program and schedules warrant.
- \_\_\_\_\_ 4. Rooms are arranged to provide maximum multiple use; specialization has been held to a minimum commensurate with specific activity requirements.
- \_\_\_\_\_ 5. Instructional spaces are readily expandable to meet increased capacity requirements and curriculum.
- \_\_\_\_\_ 6. Design of classrooms will permit later conversion to small group learning areas.
- \_\_\_\_\_ 7. Flexibility of a semi-permanent nature is effected by use of folding partitions or panels designed for area delineation.
- \_\_\_\_\_ 8. Movable partitions are designed so they can be easily and economically moved to meet changing enrollment and curriculum needs.
- \_\_\_\_\_ 9. Sinks and other fixed equipment are carefully located to permit changes in space use.
- \_\_\_\_\_ 10. Fixed mechanical and plumbing facilities are on building peripheries to preserve internal flexibility.

## Design Elements

- \_\_\_\_\_ 1. The design provides a satisfactory visual connection between the building and community.
- \_\_\_\_\_ 2. Line, form, texture, mass, and color are used to unify building groups, to unify interior and exterior spaces so that the buildings and spaces seem a part of an entire design.
- \_\_\_\_\_ 3. Scale and organization of space contributes to and intensifies the mood required for the activities housed.
- \_\_\_\_\_ 4. Partitions do more than divide space; they are designed and equipped as vertical work space to help carry out the teaching program.
- \_\_\_\_\_ 5. Economy in space utilization has been achieved, justifying every square foot of building area.
- \_\_\_\_\_ 6. Non-instructional spaces such as covered walkways are held to a minimum.
- \_\_\_\_\_ 7. Circulation spaces have been kept to a minimum for efficient flow.

# SPATIAL EVALUATION PROFILE

SCHOOL \_\_\_\_\_

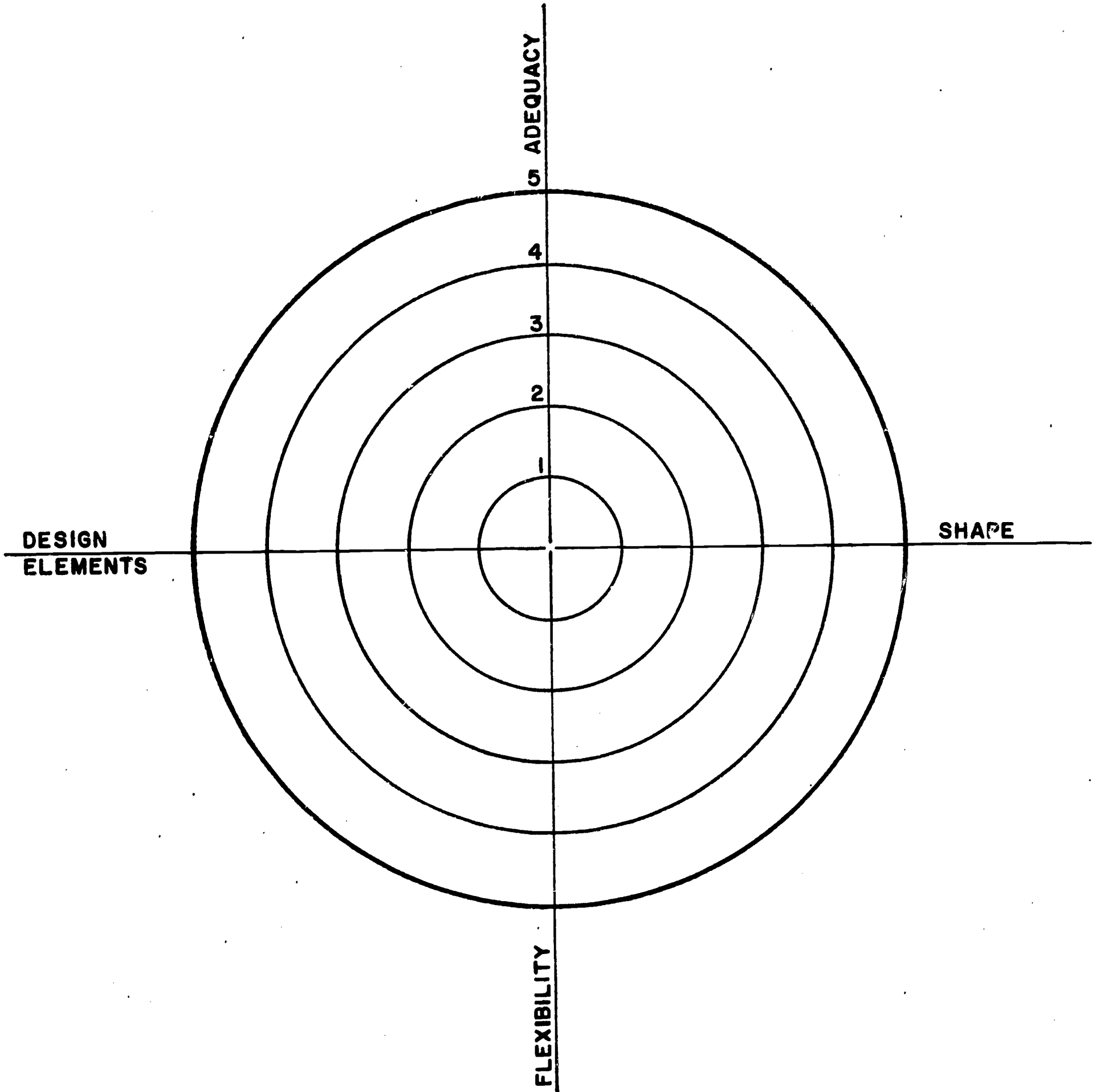

ACTUAL SCORE \_\_\_\_\_



### C. VISUAL DESIGN FACTORS

The amount of light alone does not control how well we see. For many years lighting design was thought of only in terms of how much light, or footcandles, should be provided for a particular job. The ability to see comfortably and efficiently does not increase in direct ratio to the quantity of light provided. Independent research in recent years has produced evidence that a properly designed luminous environment can help students and teachers see tasks with more comfort, speed and accuracy than possible in a poorly designed luminous environment. Perhaps even more significant is the evidence which indicates that a well balanced and controlled visual environment lessens the expenditure of energy needed by students and teachers to perform visual tasks. A properly designed luminous environment reduces fatigue, restlessness, and inattention among the individuals and contributes to the conservation of energy for physiological growth and development needs.

To assist persons using this evaluation document there are defined below the terms most used in the field of visual environment.

Footcandle is the unit by which we measure light intensity at a given point. The quantity of light falling upon a given surface may be measured in numbers of footcandles. Footcandle quantity can be measured by a relatively simple and inexpensive photo-electric meter.

Footlambert is the unit by which we measure the brightness of surfaces. The brightness of any reflecting surface in foot-lamberts is the product of the illumination in footcandles by the reflection factor of the surface. Brightness in foot-lamberts is measured by a device such as the Spectra Brightness Spot Meter.

Brightness is the luminous intensity of any surface. Brightness may be created by either reflection or direct transmission of light.

Reflection Factor is expressed as the percentage of the total amount of light falling upon a surface which is reflected by that surface. This reflected light produces brightness.

Task is interpreted to include any visual task which may be encountered in a classroom. For design and evaluation purposes, a single reference task has been established arbitrarily as a horizontal working surface with a 70% reflection factor located at the point of lowest light intensity in the classroom area.

Glare is excessively high brightness; that is, brightness differences between surfaces are exceptionally great. Direct glare represents the negative brightnesses the eye sees directly such as daylight or electric light sources in the field of view. Reflected glare is the negative brightnesses the task sees directly, but the eye sees as reflected in or from the task.

## HOW TO USE THIS EVALUATION INSTRUMENT

- Step 1. Circulate copies of the "Visual Environment Evaluation Questionnaire for Teachers" on page K-1 to those teachers occupying the room the longest period of time. Answers to the questions will identify positive or negative experiences with the lighting of the space.
- Step 2. Read each of the ten main statements starting on page C-3 and ending on page C-8, and determine by measurement or calculation which of the five conditions under each of them most closely applies to the room being evaluated.
- Step 3. From the information obtained in Step 2, score the proper number of points for each of the ten main categories and place the score in the blank at the left of each statement. Each category has a potential total of five points.
- Step 4. To obtain the average rating for the entire lighting system, add all scores and divide by ten. Place the resulting score in the space provided with the Visual Evaluation Profile on page C-9. The highest possible average score for the lighting system is five points.
- Step 5. Plot the position on the Visual Evaluation Profile as directed in each of the ten categories. Should your answer occur somewhere between any of the five conditions, plot the position on the profile by interpolation. For example, if your answer under Lighting Level should be 55 footcandles, plot a point on the profile on the Lighting Level line half-way between the third and fourth circle.
- Step 6. Draw a straight line between each of the plotted points. The greater the area of the entire circle encompassed by these joining lines, the more ideal are the visual factors of the space.

## 1. Lighting Level

The Objective: Adequate footcandles are maintained on the poorest lighted task in the general work area. The poorest level of illumination in the room can be determined simply by placing a footcandle meter (such as General Electric type 213) upright on the various desk tops about the room and reading directly from the scale of the meter.

<u>If number of footcandles is:</u>	<u>Plot circle at:</u>
70 or more	5 (biggest ring)
60	4
50	3
40	2
30	1 (smallest ring).

## 2. Sky Brightness

The Objective: Sky sources are controlled to a maximum of 250 footlamberts, enabling students to face any direction comfortably. Brightness readings (in footlamberts) of outside light to be accurate must be measured by a technical person competent in the field of illumination using a device such as the Spectra Brightness Spot Meter. Such service may be available through the headquarters office of the utility company supplying the electrical power to the school. The following table is based on using that meter.

<u>If light is controlled to:</u>	<u>Plot circle at:</u>
250 footlamberts or lower	5
350 "	4
450 "	3
550 "	2
650 "	1

Inasmuch as the above-mentioned meter may not be readily available to many school districts, the following table has been developed so that the footcandle meter again may be used. Readings should be made by holding the meter at the window glass and pointing it directly toward the sky area that is visible from within the room. It must be remembered that the resultant brightness reading is approximate and a rough guide, not to be considered as standard procedure.

<u>If light is controlled to:</u>	<u>Plot circle at:</u>
115 footcandles or lower	5
165 "	4
210 "	3
260 "	2
310 "	1

### 3. Electric Fixture Brightness

The Objective: Electric light sources do not have excessive brightness when viewed from any angle, 0 degrees (vertical) to 90 degrees (horizontal). Here, also, brightness readings (in footlamberts) to be accurate, must be measured by a technical person capable of using a Spectra Brightness Meter. As noted before, such service may be available through the headquarters office of the utility company supplying the electrical power to the school.

<u>If brightness is controlled to:</u>	<u>Plot circle at:</u>
250 footlamberts or less	5
350       "	4
450       "	3
550       "	2
650       "	1

Inasmuch as the above-mentioned meter may not be readily available to many school districts, the following two tables have been developed so that the footcandle meter again may be used. Table 1 is used when the lighting fixtures have exposed fluorescent lamps or are equipped with prismatic or lens type diffusers. Table 2 is used when the fixtures are equipped with uniformly diffused milk-white panels. Readings should be made while holding the meter directly to the bottom of the fixture below the highest source of light. It must be remembered that the resultant brightness reading is approximate and a rough guide, not to be considered as standard procedure.

Table 1 - Use for exposed lamps or prismatic lenses:

<u>If brightness is:</u>	<u>Plot circle at:</u>
100 footcandles or lower	5
140       "	4
180       "	3
220       "	2
260       "	1

Table 2 - Use for uniformly diffused panels:

<u>If brightness is:</u>	<u>Plot circle at:</u>
250 footcandles or lower	5
350       "	4
450       "	3
550       "	2
650       "	1

4. Minimum Surface Brightness

The Objective: Minimum brightness of any area greater than 12 inches in any dimension within the room shall not be less than 16 footcandles. Readings can be determined directly by pointing the footcandle meter toward the surface from a distance of about three inches. No shadow should be between the meter and the surface.

<u>If minimum brightness is:</u>	<u>Plot circle at:</u>
16 footcandles	5
13 "	4
10 "	3
7 "	2
4 "	1

5. Reflectance

The Objective: All room surfaces meet the reflectance recommendations set forth in the "American Standard Guide for School Lighting," as listed below. Reflectances can be determined by first pointing the footcandle meter cell toward the surface at a distance of about three inches. Read the figure on the scale. Then, holding the meter in the opposite direction with the meter base against the surface just measured, read the amount of light on the scale. Divide the first figure by the second figure. This will give the per cent of reflectance.

Recommendations:

Ceilings	70 - 90	per cent reflectance
Walls	40 - 60	" " "
Floors	30 - 50	" " "
Furniture and equipment	35 - 50	" " "
Chalkboards	20	" " "

<u>If room meets:</u>	<u>Plot circle at:</u>
All recommendations	5
4 "	4
3 "	3
2 "	2
1 recommendation	1



## 6. Audio Visual

The Objective: Light control provisions have been made to permit the projection of images for audio-visual instruction. Assuming properly prepared materials, adequate projection equipment and a normally comfortable seeing environment, the ability to see color and detail clearly on a screen is dependent upon the brightness ratio between the screen when illuminated by the projector turned without a projected image and the screen with the projector turned off. The brightness ratio is determined by holding the footcandle meter approximately 12 inches away from the center of the screen when taking each reading. Divide the higher figure by the lower figure.

If the ratio is:

Plot circle at:

100:1	5
75:1	4
50:1	3
25:1	2
5:1	1

## 7. Capital Cost

The Objective: The capital outlay cost of an electric lighting system shall be based upon the contractor's cost of the lighting equipment plus lamps plus \$25 per wiring outlet. The information required to compare with the following can be obtained from the school district architect.

If cost is:

Plot circle at:

60¢ per sq.ft. of classroom area (or less)	5
75¢ " " " " " "	4
90¢ " " " " " "	3
\$1.05 " " " " " "	2
\$1.20 " " " " " "	1

## 8. Operation

The Objective: The electric lighting system should operate efficiently within reasonable operating costs. In a classroom with the recommended reflectance factor on ceiling, walls, and floor, the watts per square foot to produce 70 footcandles will vary, depending upon the type and efficiency of the system. The following rating is based upon watts per square foot. The information required to compare with the following can be obtained from the school district architect.

If space has:

Plot circle at:

2	watts per square foot	5
2½	" " " "	4
3	" " " "	3
3½	" " " "	2
4	" " " "	1

9. Maintenance

The Objective: The electric lighting system will require a minimum of maintenance over the period of its rated existence.

Recommendations

- A. The cleaning frequency to maintain the designed illumination level should be no more than once a year.
- B. The light control lenses or diffusing elements of lighting fixtures should be easily removable for cleaning by the maintenance staff.
- C. The light control lenses or diffusing elements should be manufactured of glass or virgin acrylic to resist discoloration or deterioration.
- D. Relamping the lighting fixtures should be a simple process that does not require disassembly of the fixture.
- E. The fixture ballasts should be of highest quality. They should be internally fused low noise level rated units with the Certified Ballast Manufacture (C.B.M.) and Underwriters' labels.

If system meets:

Plot circle at:

All recommendations	5
4	4
3	3
2	2
1 recommendation	1

10. Design Integration

The Objective: Both daylight and electric lighting systems have been coordinated in design with the other basic design factors (spatial, thermal, sonic, aesthetic).



If this is true:

Plot circle at:

Daylight and electric lighting systems integrated in design and coordinated with the spatial, thermal, sonic and aesthetic elements;

5

Lighting systems coordinated with three of the basic design factors;

4

Lighting systems coordinated with two of the basic design factors;

3

Lighting systems coordinated with one of the basic design factors;

2

Daylight and electric lighting systems integrated.

1

# VISUAL EVALUATION PROFILE

SCHOOL

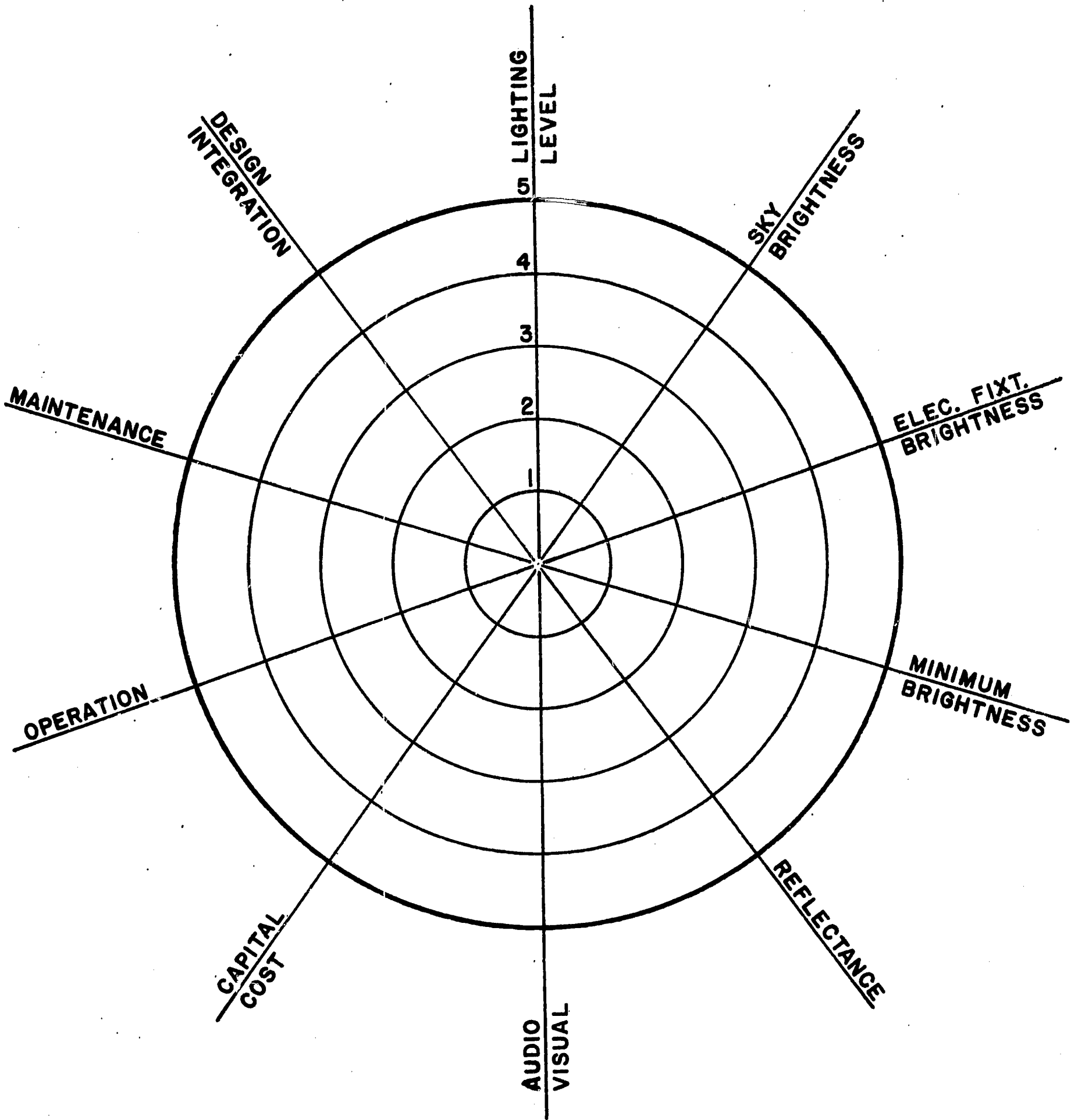

ACTUAL SCORE

#### D. THERMAL DESIGN FACTOR

Studies have shown that the quality of the thermal environment affects the physical and mental comfort of the student. Good thermal design provides a physical environment which will allow the occupants to comfortably dissipate normal body heat.

An uncomfortable thermal environment may be fatiguing and distracting to the pupils; therefore, the maintenance of the proper thermal environment is an important factor in the productive use of instructional time.

Thermal comfort is achieved when we are able to maintain our body temperature without conscious effort.

After a new school has been in operation, however, an evaluation of the thermal environment by the engineer and district staff members becomes imperative.

The thermal environment field check represents a special effort to provide a set of objectives and performance criteria which will be useful in focusing attention on important factors that affect the development of better controlled classroom environment.

#### HOW TO USE THIS EVALUATION INSTRUMENT

- Step 1. Circulate copies of the "Thermal Environment Evaluation Questionnaire for Teachers," pages L-1 to L-7, to those teachers occupying the room the longest period of time.
- Step 2. Fill out "Classroom Thermal Environment Questionnaire" at the end of this document by consulting the maintenance man at the school. Plot data on plot plan drawing attached.
- Step 3. From the above information score the proper number of points opposite each statement of criteria rating this particular building. It is recommended that you be accompanied on your visitation by a mechanical engineer.

Temperature

- \_\_\_ 1. System provides adequate warmth when heating is required.
- \_\_\_ 2. System does not overheat.
- \_\_\_ 3. System provides adequate cooling when required (either natural or mechanical).
- \_\_\_ 4. System does not provide excessive cooling.

Ventilation

- \_\_\_ 1. Ventilation system provides for control or isolation of odors from interior sources.
- \_\_\_ 2. Ventilation system provides for control of odors from exterior sources.
- \_\_\_ 3. Provision is made for adequate air movement.
- \_\_\_ 4. System does not produce air velocities over 50 feet per minute (F.P.M.) within occupied area.
- \_\_\_ 5. Adequate ventilation is provided in non-cooled spaces.

Building Shell

- \_\_\_ 1. Roof design minimizes heat gain or loss.
- \_\_\_ 2. Exterior wall design minimizes heat gain or loss.
- \_\_\_ 3. Glass areas are protected against solar radiation.
- \_\_\_ 4. Glass areas are designed to minimize heat gain or loss.
- \_\_\_ 5. Shell or building provides adequate space for and access to mechanical equipment.
- \_\_\_ 6. Mechanical equipment does not require an excessive amount of floor space.
- \_\_\_ 7. Shell of building provides for adaptation of the mechanical system to reallocation of floor areas.
- \_\_\_ 8. Ceiling and lighting system provides for freedom in relocating mechanical air supply consistent with reallocation of floor areas.

Each blank receives  
rated points or zero.

Uniformity of Room Temperature

Temperature at breathing lines does not vary above or below  
thermostat setting more than:

- 1° F. (5) points
- 2° F. (4) "
- 3° F. (3) "
- 4° F. (2) "
- 5° F. (1) point

Comfort Range (5 points or zero)

Values indicated on the sling psychrometer are within the follow-  
ing range when system is on the heating cycle:

Dry Bulb Temperature Degrees Fahrenheit

<u>% Relative Humidity</u>	<u>Minimum Degrees</u>	<u>Maximum Degrees</u>
70	68	73
60	69	74
50	70	75
40	71	77
30	72	78

Values indicated on the sling psychrometer are within the follow-  
ing range when system is on the cooling or ventilating cycle:

Dry Bulb Temperature Degrees Fahrenheit

<u>% Relative Humidity</u>	<u>Minimum Degrees</u>	<u>Maximum Degrees</u>
70	72	77
60	73	78
50	74	79
40	75	80
30	76	82

Sound Level

1. Noise level of system does not exceed the normal ambient noise level.
2. Building structure provides adequate protection against sound transmission.
3. Air distribution system does not allow sound transmission from one room to another.

# THERMAL EVALUATION PROFILE

SCHOOL \_\_\_\_\_

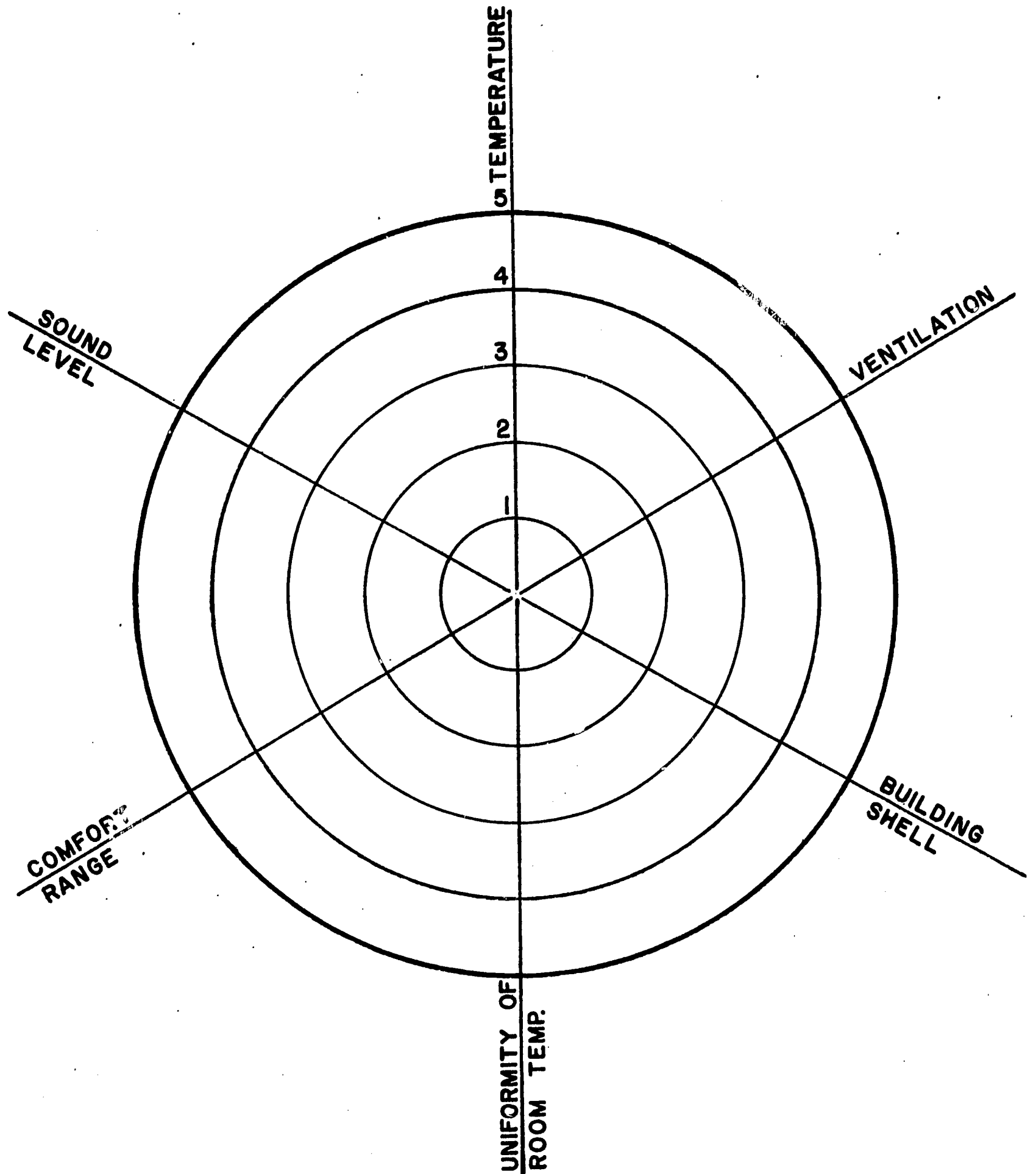

ACTUAL SCORE \_\_\_\_\_

## E. SONIC FACTORS

### Introduction

Noise can influence work output in many ways. There is the obvious interference with communication, the occasional condition where noise is useful as a means of masking distracting conversations, and the deterioration of quality of work output that can occur when the background noise level is above normal tolerance.

### Definition

Although to many people the decibel is uniquely associated with noise measurement, it is a term borrowed from electrical communication engineering, and it represents a relative quantity. When it is used to express noise level a reference level is implied. For the present, the reference level can be referred to as 0 decibels, the starting point of the scale of noise levels. This starting point is about the level of the weakest sound that can be heard by a person with very good hearing in an extremely quiet location. These typical values should help to develop a feeling for this term "decibel" as applied to sound level.

### Decibels:

- 110 Thunder, airplane motors, pneumatic hammers
- 90 Noisy factory areas
- 70 Noisy office; factory area, moderately noisy
- 50 Typical office with acoustical treatment
- 30 Typical living room (comfortable, pleasant)
- 10 Rustle of leaves (barely audible)

### Reduction of Interior Noise

- \_\_\_\_\_ 1. Use of full area, thick carpeting to stop unwanted sounds at their source.
- \_\_\_\_\_ 2. Use of double partitions between walls to eliminate sound transmission between rooms.
- \_\_\_\_\_ 3. Pipe penetrations of walls and slabs caulked or otherwise made sound-tight by pipe wrappings.
- \_\_\_\_\_ 4. Wall partitions designed to reduce sound transmission from adjoining rooms to the lowest possible level.
- \_\_\_\_\_ 5. Sound leaks in walls sealed through the use of packing, caulking, and plaster.



- \_\_\_\_\_ 6. Use of soft, porous materials such as wood, fibreboard, fabric, or furnishings.
- \_\_\_\_\_ 7. Restricted use of louvered door ventilators.
- \_\_\_\_\_ 8. Evidence of noise from air conditioning system, fans, and air moving through grills.
- \_\_\_\_\_ 9. Sound-absorptive materials placed as borders around the edges of ceilings and at the top of walls.
- \_\_\_\_\_ 10. Use of upholstered chairs to eliminate auditorium noise.
- \_\_\_\_\_ 11. Use of absorptive treatment for rear walls which might cause echoes.
- \_\_\_\_\_ 12. Use of convex surface and non-parallelism to eliminate flutter tumble echo caused by sound which goes from wall to wall.

#### Reduction of Exterior Noises

- \_\_\_\_\_ 1. Orientation of building to face quietest exposure.
- \_\_\_\_\_ 2. Minimize number of windows facing noise exposures.
- \_\_\_\_\_ 3. Windows for adjoining classrooms spaced maximum distance apart.
- \_\_\_\_\_ 4. Building designed to avoid deep courts and yards.
- \_\_\_\_\_ 5. Use of plantings and landscaping to eliminate noise source.
- \_\_\_\_\_ 6. Use of double glazing for exposed windows.
- \_\_\_\_\_ 7. Noisy building areas isolated from areas requiring quiet.
- \_\_\_\_\_ 8. Classrooms and corridors opening onto quiet areas and not onto busy streets.
- \_\_\_\_\_ 9. Elimination of outdoor sound reflective surfaces on ground and buildings.

#### Acoustic Design

- \_\_\_\_\_ 1. Use of effective, airtight seals as a sound barrier for operable walls and partitions.
- \_\_\_\_\_ 2. Operable walls and partitions with equal acoustic standards of the building.

- \_\_\_\_\_ 3. Interior surfaces of rooms shaped to provide good sound diffusion.
- \_\_\_\_\_ 4. Ceilings shaped to create a non-parallel diffusing surface for high noise level rooms.
- \_\_\_\_\_ 5. Installation of sound absorption acoustical material in patches or strips rather than in a continuous surface.
- \_\_\_\_\_ 6. Use of special sound retardant doors with sealed edges for door openings between noisy and quiet areas.
- \_\_\_\_\_ 7. Placement of sound absorbent treatment low enough on walls to prevent echoes.
- \_\_\_\_\_ 8. Use of secondary ceiling suspended on springs and isolated with cork strips from walls with an acoustic tile ceiling which acts as a noise bumper for schools located near airports.
- \_\_\_\_\_ 9. Use of splays to break up concave surfaces or large flat areas and help diffuse reflections.

#### Sound Isolation

- \_\_\_\_\_ 1. Use of acoustically-lined elbows on the ceiling side of air grills.
- \_\_\_\_\_ 2. Pipe connections to pumps have flexible connections.
- \_\_\_\_\_ 3. Vibration isolation mounts used to support noisier equipment.
- \_\_\_\_\_ 4. Air conditioning and mechanical equipment not located on roof of buildings.
- \_\_\_\_\_ 5. Elimination of back-to-back electrical outlets.
- \_\_\_\_\_ 6. Use of sound retardant door installations with adjustable seals and automatic threshold closures.
- \_\_\_\_\_ 7. Use of resilient mounting for fluorescent lamp ballasts.

# SONIC EVALUATION PROFILE

SCHOOL \_\_\_\_\_

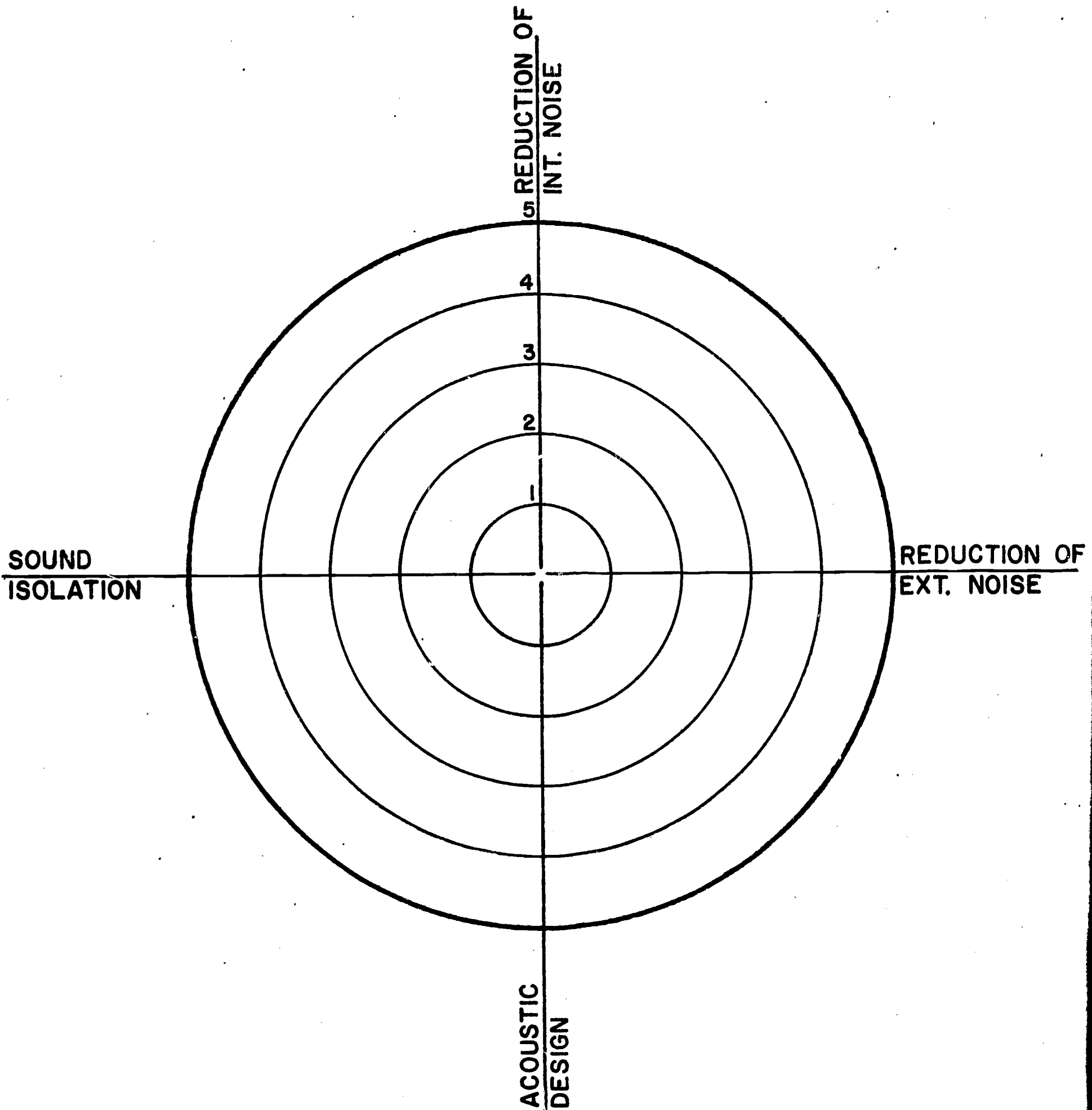

ACTUAL SCORE \_\_\_\_\_

## F. AESTHETIC FACTORS

Aesthetic guidelines that can be applied to construction projects are needed whether or not the user is particularly aesthetically-oriented. An overall policy is needed that establishes the values toward which the program will be directed.

A policy, so developed, should cover attitudes toward aesthetic effect and its relative importance in the list of values. It should cover such items as landscaping, color openings, suitability of design to surroundings, concealment of clutter, as well as attitudes toward human values in school building such as overall character and feeling. Such a policy would of necessity have to be broad in order not to become a set of standards or restrictions of design. From the broad statement of policy, the administrator could draw up a checklist that could be changed or supplemented as time and experience dictate, from which judgment of individual projects could be made.

## Objectives

- \_\_\_\_\_ 1. The main entrance is easily identified and can be found readily by visitors to the school. Service entrances are accessible and serve their intended function while being screened from view.
- \_\_\_\_\_ 2. The exterior presents an attractive and welcoming appearance. The window and door openings are arranged harmoniously.
- \_\_\_\_\_ 3. The buildings reflect the variety of activities that will take place both inside and outside the buildings.
- \_\_\_\_\_ 4. Provision has been made for quiet, restful areas that are inviting. Circulation between elements seems easy and natural, both for the individual and for the group.
- \_\_\_\_\_ 5. The overall landscape design is developed with an understanding of function and maintenance resulting in an integrated whole.
- \_\_\_\_\_ 6. Choice and use of materials indicate a concern for suitability and maintenance as well as design originality.
- \_\_\_\_\_ 7. Buildings are so placed and designed to reflect humanistic atmosphere rather than a massive industrialized impression.

## Unity and Proportion

- \_\_\_\_\_ 1. The plant design presents a picture of continuity of form with every part related to other parts and to the whole.
- \_\_\_\_\_ 2. Contrasting forms are used to create visual interest.

## Fluid Quality in Space

- \_\_\_\_\_ 1. Similar materials are used from one building to another to aid in the feeling of continuity.
- \_\_\_\_\_ 2. Utilities and other non-aesthetic items are concealed or masked with relation to the whole design; i. e., the roofs have a minimum of protruding vents, ducts, and other mechanical devices.
- \_\_\_\_\_ 3. The design avoids the use of current fads and novelty building materials which would tend to date the structures.

### Use of Color

- \_\_\_\_\_ 1. The color scheme is pleasing. The colors and textures of building materials will wear well and be easy to maintain.
- \_\_\_\_\_ 2. Vents, louvres, and other non-aesthetic items have been painted the color of adjacent wall or roof surfaces to blend them into the background insofar as possible.
- \_\_\_\_\_ 3. Appropriate colors have been used for work areas.
- \_\_\_\_\_ 4. Cheerful color has been used for cafeteria and assembly rooms.
- \_\_\_\_\_ 5. Color has been used to identify objects.
- \_\_\_\_\_ 6. Color has been used to identify danger zones.

# AESTHETICS EVALUATION PROFILE

SCHOOL \_\_\_\_\_

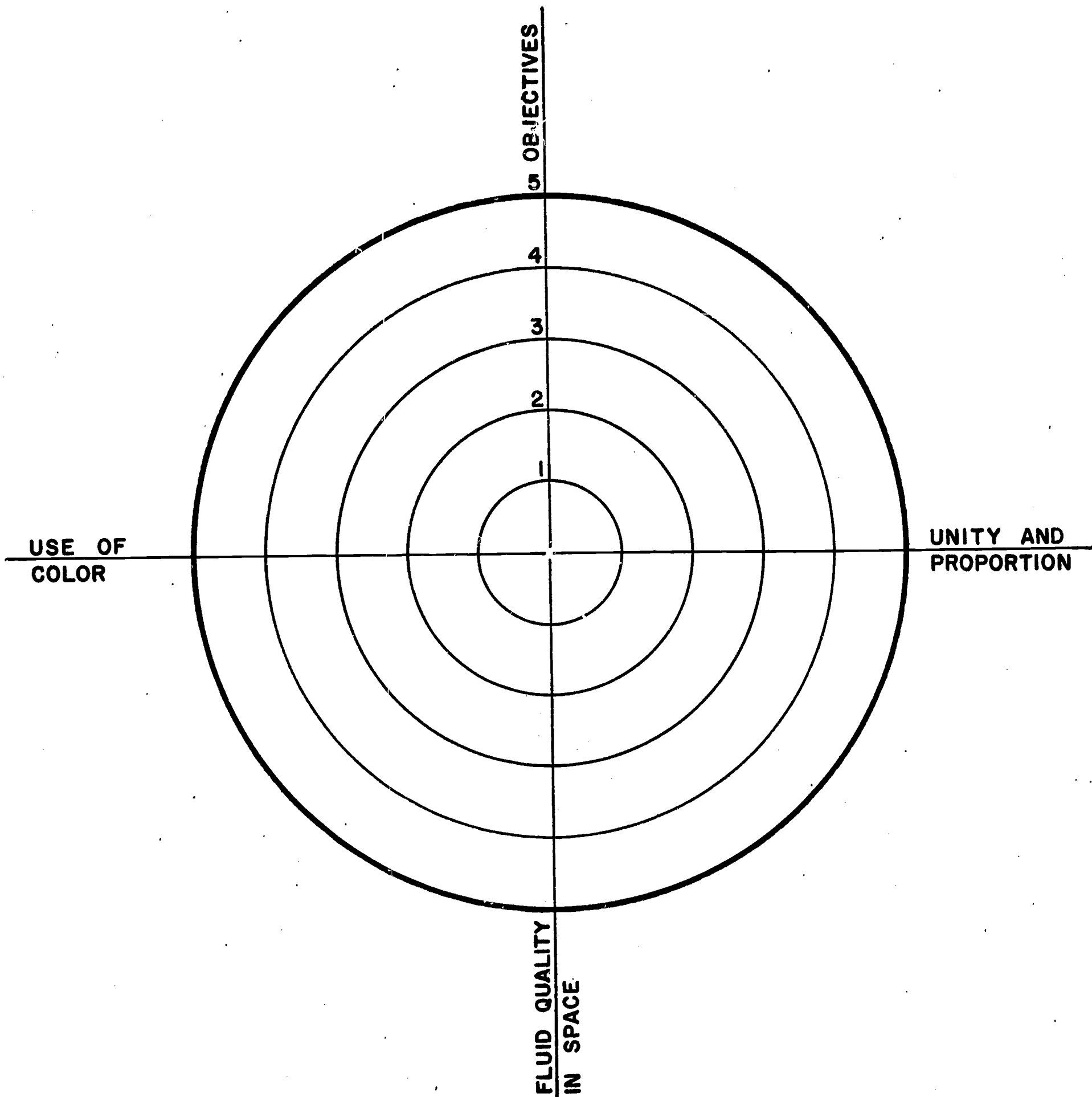

ACTUAL SCORE \_\_\_\_\_



## G. AUDIO VISUAL DESIGN FACTORS

There is an obligation to design a school facility not only for today, but for years to come; aimed at providing a physical environment that will encourage the most efficient teaching and learning climate.

No attempts will be made to recommend specific audio-visual equipment or systems, but rather to present items that should be considered in the evaluation of an existing plant. These items should be considered in the educational specifications for new school facilities in order to avoid expensive alterations at a later date.

**EDUCATIONAL TELEVISION:** Educational television in schools in the future will have both open and closed circuit channels; therefore, the existing schools and those being planned need to provide the conduit and outlets necessary to handle television receivers or cameras.

- \_\_\_\_\_ 1. Adequate conduits have been provided for both open and closed television circuits (minimum size conduit 1-inch with no bends to less than 6-inch radius).
- \_\_\_\_\_ 2. Adequate electrical outlets have been provided on separate circuits from other classrooms for all the audio-visual equipment.
- \_\_\_\_\_ 3. An outlet has been provided for the use of an overhead television camera in each room.
- \_\_\_\_\_ 4. Provision has been made for mounting the television receiver or receivers in the best viewing locations in each room.
- \_\_\_\_\_ 5. Consideration has been given to providing a cable from instructor to receiver to enable the instructor to adjust receiver and override both video and audio signals with the local cameras.

**PROJECTION:**

- \_\_\_\_\_ 1. Adequate electrical outlets have been provided and so placed to the best advantage of the teacher and viewer.
- \_\_\_\_\_ 2. Provision has been made for mounting a wall type screen to reduce image distortion.
- \_\_\_\_\_ 3. Provision has been made for auxiliary speakers to be installed in the front or back of the room for use with the projectors or amplifiers.
- \_\_\_\_\_ 4. Adequate light control has been provided for window areas.
- \_\_\_\_\_ 5. One bank of lights in the classroom has been installed on a separate switch so that the teacher can eliminate direct light on the screen.

**STORAGE AND DISPLAY AREAS:**

- \_\_\_\_\_ 1. A minimum of 20 linear feet each of chalk and tack board with map rails has been provided in each classroom.
- \_\_\_\_\_ 2. Shelving and counter space have been provided for displays.
- \_\_\_\_\_ 3. Provision has been made for efficient storage and distribution of audio-visual materials and equipment.

- \_\_\_\_\_ 4. Space has been provided for an instructional materials center to enable the teachers to preview audio-visual materials.
- \_\_\_\_\_ 5. Door sills have been installed to permit easy transportation of audio-visual equipment.

AUDIO-VISUAL EQUIPMENT:

- \_\_\_\_\_ 1. The various pieces of audio-visual equipment are standardized for ease of maintenance and spare parts.
- \_\_\_\_\_ 2. The quality of equipment enables economical operation and a minimum of maintenance.
- \_\_\_\_\_ 3. Equipment should be of such design so as to facilitate operation (i.e., automatic threading).
- \_\_\_\_\_ 4. The wheels or casters are of sufficient size to allow ease of movement over walks and doorsills without damage to the audio-visual equipment.
- \_\_\_\_\_ 5. The audio-visual cart is of adequate size to allow safe movement of the equipment.

# AUDIO-VISUAL EVALUATION PROFILE

SCHOOL \_\_\_\_\_

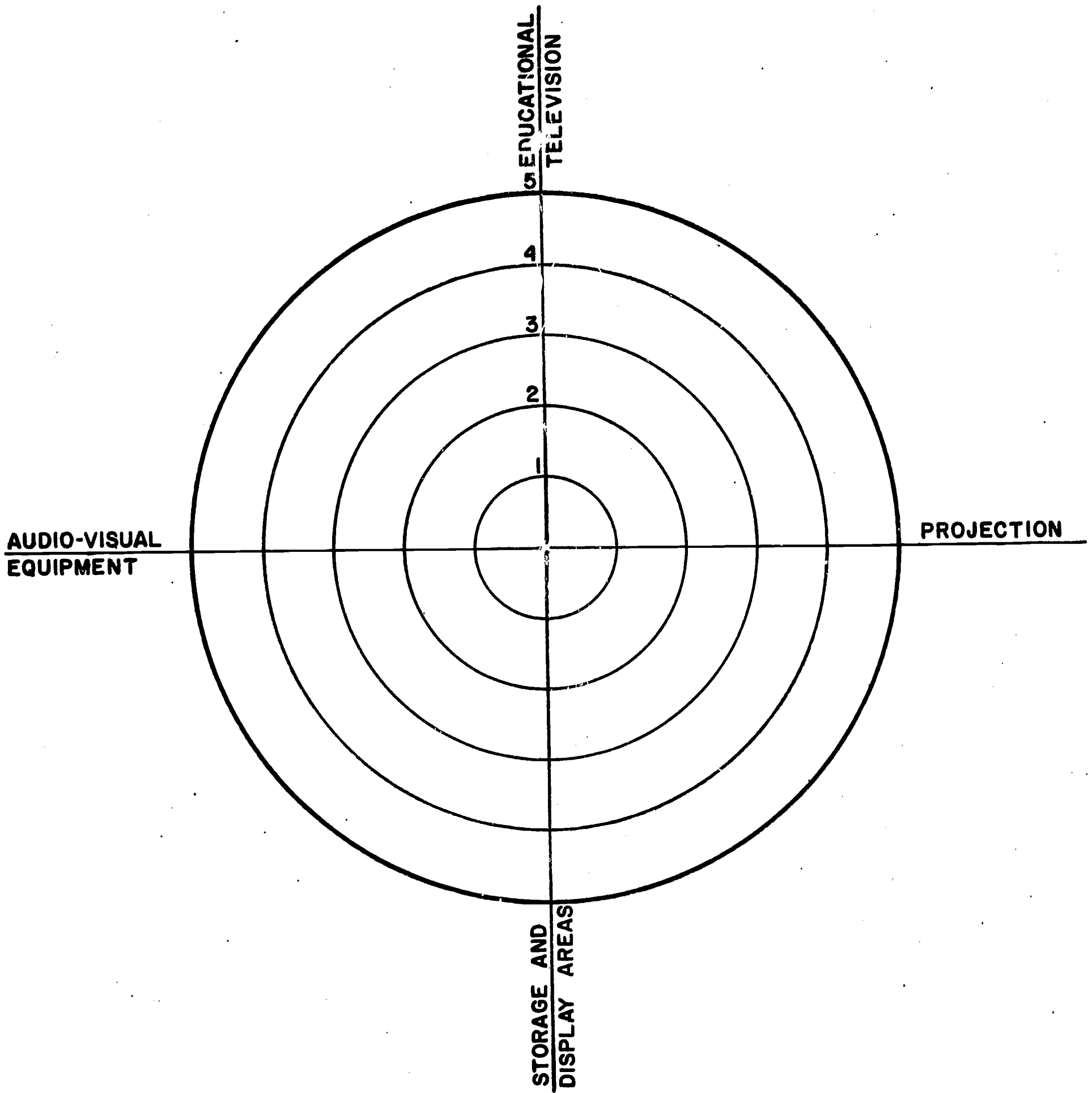

ACTUAL SCORE \_\_\_\_\_

## H. EQUIPMENT FACTORS

### Durability

- \_\_\_\_\_ 1. Classroom equipment purchased from manufacturers who emphasize durability and have subjected equipment to extensive tests to guarantee quality.
- \_\_\_\_\_ 2. Use of furniture and equipment with a service life of 20 to 25 years.
- \_\_\_\_\_ 3. Use of furniture and equipment that will retain original appearance for long periods of time.
- \_\_\_\_\_ 4. Use of materials that are not easily defaced and help maintain a new appearance for an extended period of time.
- \_\_\_\_\_ 5. Use of scuff strips or non-corroding materials on those areas that are subject to abrasive wear.
- \_\_\_\_\_ 6. Use of special glides that will not mark or dent resilient floor tiles or carpeting.

### Flexibility

- \_\_\_\_\_ 1. Furniture and equipment designed to allow for a maximum re-arrangement of all the elements that are part of the teaching and learning environment.
- \_\_\_\_\_ 2. Use of carrels that are capable of movability and variable arrangements comparable to the conventional desk and chair.
- \_\_\_\_\_ 3. Design emphasis in classroom furniture in keeping with contemporary architecture.
- \_\_\_\_\_ 4. Use of versatile functional equipment.
- \_\_\_\_\_ 5. Use of modular furniture units that facilitate flexible grouping.
- \_\_\_\_\_ 6. Use of mobile cabinets for more flexible room arrangement.

### Design Factors

- \_\_\_\_\_ 1. Building plans designed to consider the coordination of interior finish, color, and textures with the color and finish of the furniture and equipment selection.

- \_\_\_\_\_ 2. Storage units for equipment designed to permit change, expansion, and that can be added to or moved to any critical area.
- \_\_\_\_\_ 3. Equipment designed to permit instructor to help individual students, or teams of students at their station without interference to other students.
- \_\_\_\_\_ 4. Furniture designed for appearance, comfort, correct posture, and resistance to breakage.
- \_\_\_\_\_ 5. Chair legs are not so far apart as to cause tripping and difficulties in fitting them under tables and desks.
- \_\_\_\_\_ 6. Chair legs are extended in back so that chair will not hit wall.
- \_\_\_\_\_ 7. Furniture design based on educational need and on physiological characteristics of the users.

#### Selectivity

- \_\_\_\_\_ 1. Availability of equipment for seeing comfort and efficiency, such as light transmission devices, television, picture projectors, and screens.
- \_\_\_\_\_ 2. Availability of equipment for hearing comfort and efficiency. Devices to reduce reverberation--draperies, carpeting, and plantings.
- \_\_\_\_\_ 3. Availability of devices to reduce sound transmission such as storage partition, carrels, and movable walls.
- \_\_\_\_\_ 4. Availability of devices to transmit and amplify sound, microphones, tape recorders, and public address systems.
- \_\_\_\_\_ 5. Availability of equipment to move, hold things: carts, stands, and counters.
- \_\_\_\_\_ 6. Availability of equipment or tools for aesthetic purposes such as paintings, photographs, sculpture, mosaic, and planting.

#### Sufficiency

- \_\_\_\_\_ 1. Built-in equipment designed, installed and connected so as not to interfere with building construction elements (vent pipes passing through cabinets).
- \_\_\_\_\_ 2. Built-in equipment installed without alteration to building structure.

- \_\_\_\_\_ 3. Chair desks with full-width tablets across the front which provide an adequate writing surface for left-handed students.
- \_\_\_\_\_ 4. Sufficient quantity of open shelves and closed cabinets.
- \_\_\_\_\_ 5. Correctly dimensioned seating which does not cause postural distortion.
- \_\_\_\_\_ 6. Equipment sized to operational or functional needs of the pupils.



# EQUIPMENT EVALUATION PROFILE

SCHOOL \_\_\_\_\_

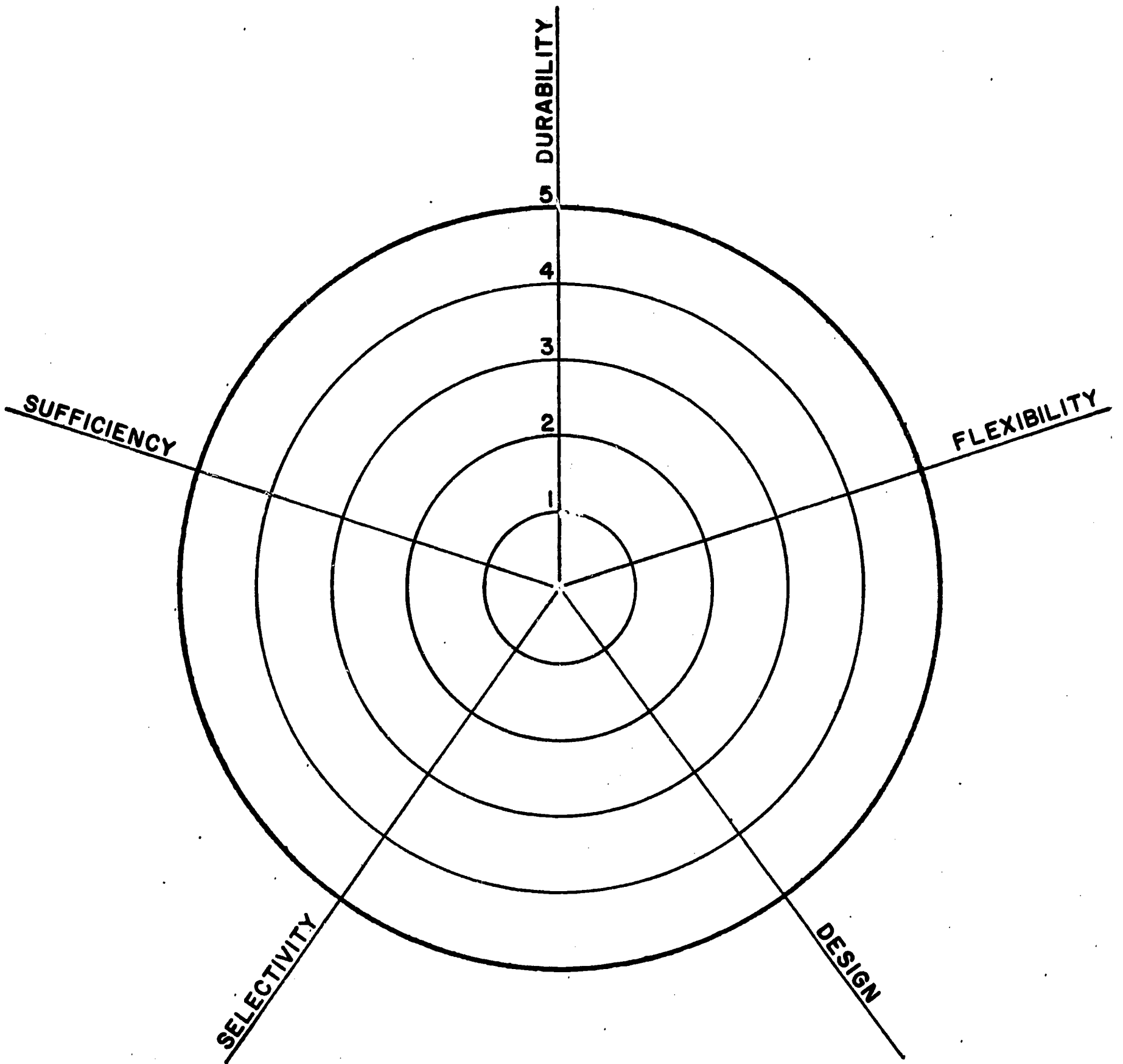

ACTUAL SCORE \_\_\_\_\_

## I. SAFETY DESIGN FACTORS

Schoolhouse facilities must be planned with a high degree of consideration given to the safety of pupils, employees, and visitors. Liability of the school district, as established by the courts, necessitates the strictest control.

### OFF-SITE FACTORS

- \_\_\_\_\_ 1. Adequate crosswalks, signs, or signals provided for adjacent streets.
- \_\_\_\_\_ 2. Street parking on school side of street eliminated in areas where pupils cross the street.
- \_\_\_\_\_ 3. Main entrance to school located on the street having the lightest traffic load.
- \_\_\_\_\_ 4. Streets adjacent to school site of an adequate width to allow through traffic when buses or cars are parked for loading or unloading.
- \_\_\_\_\_ 5. Walks of adequate width on perimeter parkways.

### ON-SITE FACTORS

- \_\_\_\_\_ 1. Pedestrian entrances and vehicular entrances to site properly separated.
- \_\_\_\_\_ 2. Concrete walk surfaces rough enough to prevent slipping when wet.
- \_\_\_\_\_ 3. Adequate entrances into large sites provided for fire fighting and emergency vehicles.
- \_\_\_\_\_ 4. Parking areas located so as to avoid pupil cross traffic.
- \_\_\_\_\_ 5. Truck delivery and trash pick-up areas located so that trucks will not enter playground or student traffic areas.
- \_\_\_\_\_ 6. Play areas have been oriented to provide maximum supervision with minimum personnel.
- \_\_\_\_\_ 7. Catch basins and utility boxes have been vandal-proofed and so located as to minimize safety hazards in the play areas.

### EXTERIOR BUILDING DESIGN FACTORS

- \_\_\_\_\_ 1. All entrances to buildings are on grade wherever possible.
- \_\_\_\_\_ 2. Arcade posts have been eliminated just outside of all exit doors and in main passageways.
- \_\_\_\_\_ 3. Doors to classrooms swing toward normal line of traffic in corridor.
- \_\_\_\_\_ 4. Adequate lighting provided for all stairwells and passages for both day and evening school use.
- \_\_\_\_\_ 5. Buildings oriented in a manner that will encourage pupils to use all exits.

### INTERIOR BUILDING DESIGN FACTORS

- \_\_\_\_\_ 1. Windows in shop classrooms properly protected to avoid glare of direct sunlight in machine areas.
- \_\_\_\_\_ 2. Corridors wide enough for smooth flow of traffic where hall lockers are installed.
- \_\_\_\_\_ 3. Light controls are located so that they are accessible without walking across dark areas.
- \_\_\_\_\_ 4. Large panes of glass going to or near the floor line in student traffic areas have been eliminated or adequately marked.
- \_\_\_\_\_ 5. Safety glass has been installed in all doors, office partitions, and low windows as a precaution against injury.
- \_\_\_\_\_ 6. Kitchen, shower, and locker room floors have been designed to minimize slipping.
- \_\_\_\_\_ 7. A keyed master valve has been provided for classroom gas valves.
- \_\_\_\_\_ 8. An emergency shut-off switch has been provided for electrically operated classroom equipment.
- \_\_\_\_\_ 9. Toilet rooms are located away from stairways or other congestion areas.
- \_\_\_\_\_ 10. Student lockers are located away from congestion areas.

# SAFETY EVALUATION PROFILE

SCHOOL \_\_\_\_\_

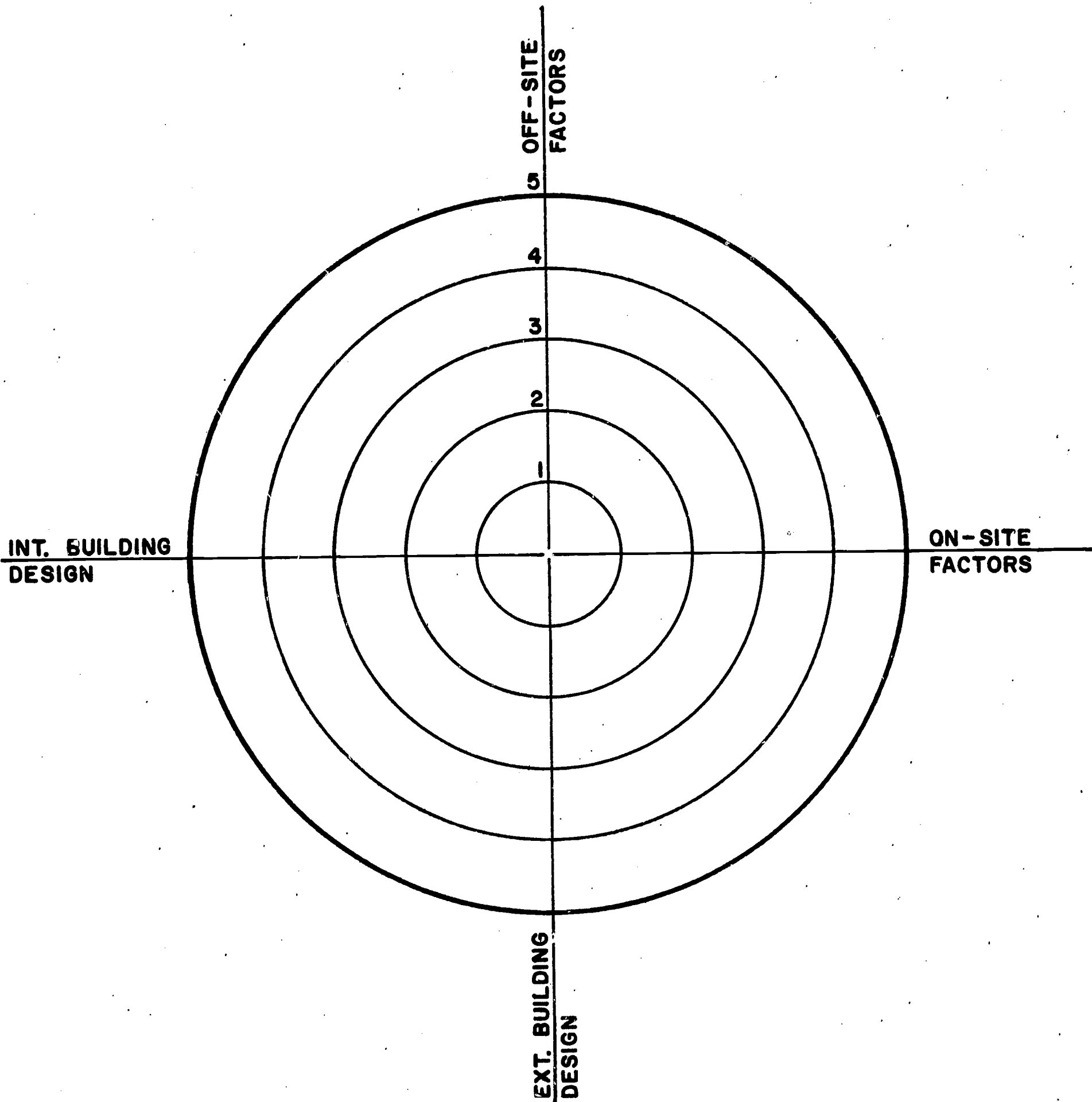

ACTUAL SCORE \_\_\_\_\_

## J. MAINTENANCE DESIGN FACTOR

Excessive maintenance and operational costs take dollars away from the educational budget.

### SITE DEVELOPMENT

- \_\_\_\_\_ 1. All sidewalks and arcades drain away from the building.
- \_\_\_\_\_ 2. Adequate drainage channels are provided under arcades and sidewalks.
- \_\_\_\_\_ 3. The paved and turfed areas are adequately drained.
- \_\_\_\_\_ 4. Adequate expansion joints are provided in all concrete areas.
- \_\_\_\_\_ 5. Expansive soil problems have been solved.
- \_\_\_\_\_ 6. Adequate walks for cross traffic to various buildings on the campus have been provided in the best traffic pattern.
- \_\_\_\_\_ 7. Access to all passage ways and landscape areas has been provided for deliveries, sweepers, lawnmower, and garden equipment.
- \_\_\_\_\_ 8. The sprinkling system for landscape areas has been designed so as not to sprinkle the buildings.

### BUILDING DESIGN

- \_\_\_\_\_ 1. Corrosion and electrolysis protection has been provided.
- \_\_\_\_\_ 2. Galvanized or aluminum surfaces have not been painted.
- \_\_\_\_\_ 3. The building has been designed to minimize recesses and projections.
- \_\_\_\_\_ 4. The floor covering has been selected to minimize maintenance.
- \_\_\_\_\_ 5. Low maintenance type doors have been selected.
- \_\_\_\_\_ 6. Materials have been used that reduce painting to a minimum.

## HARDWARE AND FIXTURES

- \_\_\_\_\_ 1. Quality materials have been used in order to keep maintenance costs at a minimum.
- \_\_\_\_\_ 2. The district has standardized on brands of fixtures in order to assure lower maintenance and inventory costs.
- \_\_\_\_\_ 3. Fixtures that are bolted or screwed down are fastened with vandal-proof screws and bolts.
- \_\_\_\_\_ 4. Proper voltage outlets have been provided in rooms and corridors

## PLUMBING

- \_\_\_\_\_ 1. Cleanouts and control boxes have been designed to minimize damage and vandalism.
- \_\_\_\_\_ 2. Adequate cleanouts have been provided for utility lines.
- \_\_\_\_\_ 3. Provides adequate access for maintenance personnel to work on pipes, equipment, and filters.
- \_\_\_\_\_ 4. Floor drains with adequate floor slope have been provided for the restroom and shower locker rooms.
- \_\_\_\_\_ 5. The water used for heating has been chemically tested and treated.
- \_\_\_\_\_ 6. Adequate shut-off valves for water and gas have been provided.

## MECHANICAL

- \_\_\_\_\_ 1. Permanent filter materials have been provided.
- \_\_\_\_\_ 2. Adequate ventilation in storage rooms has been provided.
- \_\_\_\_\_ 3. Adequate ventilation has been provided for restroom areas.
- \_\_\_\_\_ 4. Adequate ventilation and drying space has been provided in locker rooms and athletic storage areas.
- \_\_\_\_\_ 5. Vandal-proof louvers and downspout materials have been provided.

# MAINTENANCE EVALUATION PROFILE

SCHOOL \_\_\_\_\_

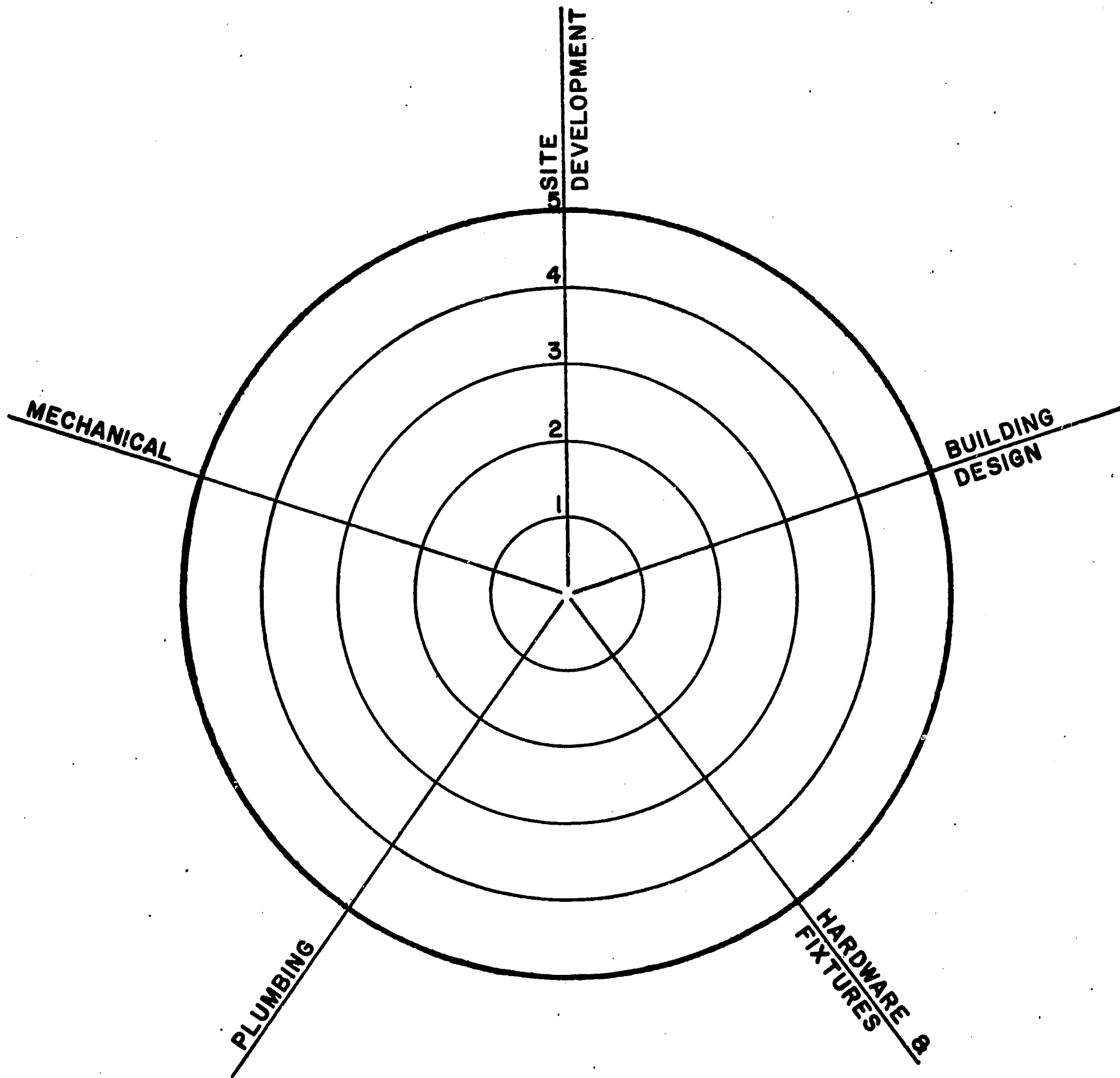

ACTUAL SCORE \_\_\_\_\_



VISUAL ENVIRONMENT EVALUATION QUESTIONNAIRE FOR TEACHERS

School District \_\_\_\_\_

School Name \_\_\_\_\_

Building Designation \_\_\_\_\_ Room No. \_\_\_\_\_

Grade Level of Students \_\_\_\_\_

Subject Taught - if this is an Intermediate or Secondary school  
\_\_\_\_\_

After completing this form, return to \_\_\_\_\_

1. Does the level of illumination within the classroom appear adequate for seeing all general visual tasks with ease? ( ) Yes ( ) No
2. Does the teacher or do the students, when in a seated or standing position in the classroom, experience glare from lighting fixture surfaces or through window glass? ( ) Yes ( ) No
3. Are operable windows located so that sky glare is controlled by roof overhang or other interior or exterior device? ( ) Yes ( ) No
4. Is direct sunlight shielded from the interior during normal school session? ( ) Yes ( ) No
5. Are there reflections on the chalkboards from the electric lighting or daylighting sources? ( ) Yes ( ) No
6. Is there sufficient contrast between the color of the chalkboard and the chalk line? ( ) Yes ( ) No
7. Is it necessary to alter the artificial or natural lighting of the classroom for audio-visual presentation? ( ) Yes ( ) No
8. Is there any objectionable humming or buzzing noise emanating from the lighting fixture system? ( ) Yes ( ) No
9. Is the lighting system in conflict with any other design element within the classroom? ( ) Yes ( ) No
10. Is adequate exterior night lighting provided on the campus for safe pedestrian circulation and protection against vandals? ( ) Yes ( ) No

THERMAL ENVIRONMENT EVALUATION QUESTIONNAIRE FOR TEACHERS

School District \_\_\_\_\_

School Name \_\_\_\_\_

Building Designation \_\_\_\_\_ Room No. \_\_\_\_\_

Grade Level of Students \_\_\_\_\_

Subject Taught - if this is an Intermediate or Secondary school \_\_\_\_\_

After completing this form, return to \_\_\_\_\_

(NOTE: If answer to the numbered question is NO, the lettered questions need not be answered.)

1. Is there a problem regarding air circulation in the classroom:  
( ) YES ( ) NO

a. What seems to be the problem? (Explain in your own words.)

\_\_\_\_\_  
\_\_\_\_\_  
\_\_\_\_\_

b. Do you feel that air circulation rate should be increased?

( ) YES ( ) NO

c. Do you notice any drafts from air supply system? ( ) YES ( ) NO

d. Do you notice any part of the room where the air circulation varies from the norm? ( ) YES ( ) NO

e. If answer to d. is YES, state at which location or locations air circulation appears to be below normal:

\_\_\_\_\_  
\_\_\_\_\_  
\_\_\_\_\_

f. If answer to d. is YES, state at which location(s) air circulation rate appears to be above normal and creating excessive drafts:

\_\_\_\_\_  
\_\_\_\_\_  
\_\_\_\_\_

2. Does room ever appear to be too warm? ( ) YES ( ) NO

a. Does this condition occur in any specific location? Explain in your own words:

---

---

b. Give times of day when this condition occurs: \_\_\_\_\_

---

3. Does room ever appear to be too cold? ( ) YES ( ) NO

a. Does this condition occur in any specific location? Explain in your own words:

---

---

b. Give times of day when this condition occurs: \_\_\_\_\_

---

4. Is odor ever a problem? ( ) YES ( ) NO

a. Describe odor: \_\_\_\_\_

---

---

b. Give times of day when this odor exists or is most persistent:

---

---

c. Does this odor exist when entering the classroom in the morning?  
( ) YES ( ) NO

---

d. Does this odor exist when entering the classroom after a weekend or vacation?  
( ) YES ( ) NO

---

e. Where do you think this odor is coming from? \_\_\_\_\_

---

---

f. Is there any possibility that the odor may be a body odor and is produced by a particular student or students? ( ) YES ( ) NO

g. Could odor be caused by a brand of perfume used by one or more of your students to which you may be particularly sensitive?  
( ) YES ( ) NO

h. Give a brief statement of your reaction to this odor problem:

---

---

---

---

---

---

---

5. Do you feel that the air circulation system or equipment creates an excessive noise level? ( ) YES ( ) NO

a. Describe the type of noise which creates this condition: \_\_\_\_\_

---

---

---

b. Does this condition occur in a greater or lesser degree at specific locations in the room? Describe:

---

---

---

---

c. Give times of day when condition persists: \_\_\_\_\_

---

6. Do you feel that the air circulating system has any effect on the cleanliness of the room? ( ) YES ( ) NO

a. Describe how: \_\_\_\_\_

---

---

7. Is excessive humidity ever a problem? ( ) YES ( ) NO

8. Is static electricity a problem? ( ) YES ( ) NO

9. Do outside weather conditions affect the thermal environment?

YES  NO

Describe how: \_\_\_\_\_  
\_\_\_\_\_  
\_\_\_\_\_

10. Is there a wall thermostat in your classroom?  YES  NO

a. Do you feel that it is working properly?  YES  NO  
(If answer is YES, disregard the following questions under Item 10.)

b. If answer to question a. is NO, describe: \_\_\_\_\_  
\_\_\_\_\_  
\_\_\_\_\_

c. Do you feel that the thermostat should have been installed in a different location?  YES  NO

d. Does thermostat have a thermometer?  YES  NO

e. Do you feel that the thermometer is accurate?  YES  NO

f. If answer to question e. is NO, explain: \_\_\_\_\_  
\_\_\_\_\_  
\_\_\_\_\_

g. Do you feel that the temperature setting of the thermostat is proper?  YES  NO

h. If answer to question g. is NO, is setting too high? \_\_\_\_\_,  
too low? \_\_\_\_\_.

11. Do you ever leave your doors open during class time?  YES  NO

If answer is YES, explain why: \_\_\_\_\_  
\_\_\_\_\_  
\_\_\_\_\_

12. Rating the overall thermal environment of your room:

a. Check one of the following:

Excellent ( )    Good ( )    Satisfactory ( )    Poor ( )  
Not Acceptable ( )

b. State any additional thoughts you may have regarding thermal environment of your room:

---

---

---

---

---

---

---

CLASSROOM THERMAL ENVIRONMENT QUESTIONNAIRE

(to be answered by Technician)

- (a) Are there any supply registers in the walls?  YES  NO
- (b) Are there any ceiling supply diffusers?  YES  NO
- (c) Are there any return air registers?  YES  NO
- (d) Is room air circulated by a unit ventilator or similar device located within the room?  YES  NO
- (e) Is there a wall thermostat in this room?  YES  NO
- (f) Are there any windows in this room?  YES  NO
- (g) Are there any wall or ceiling relief air registers connected to the outside located in this room?  YES  NO



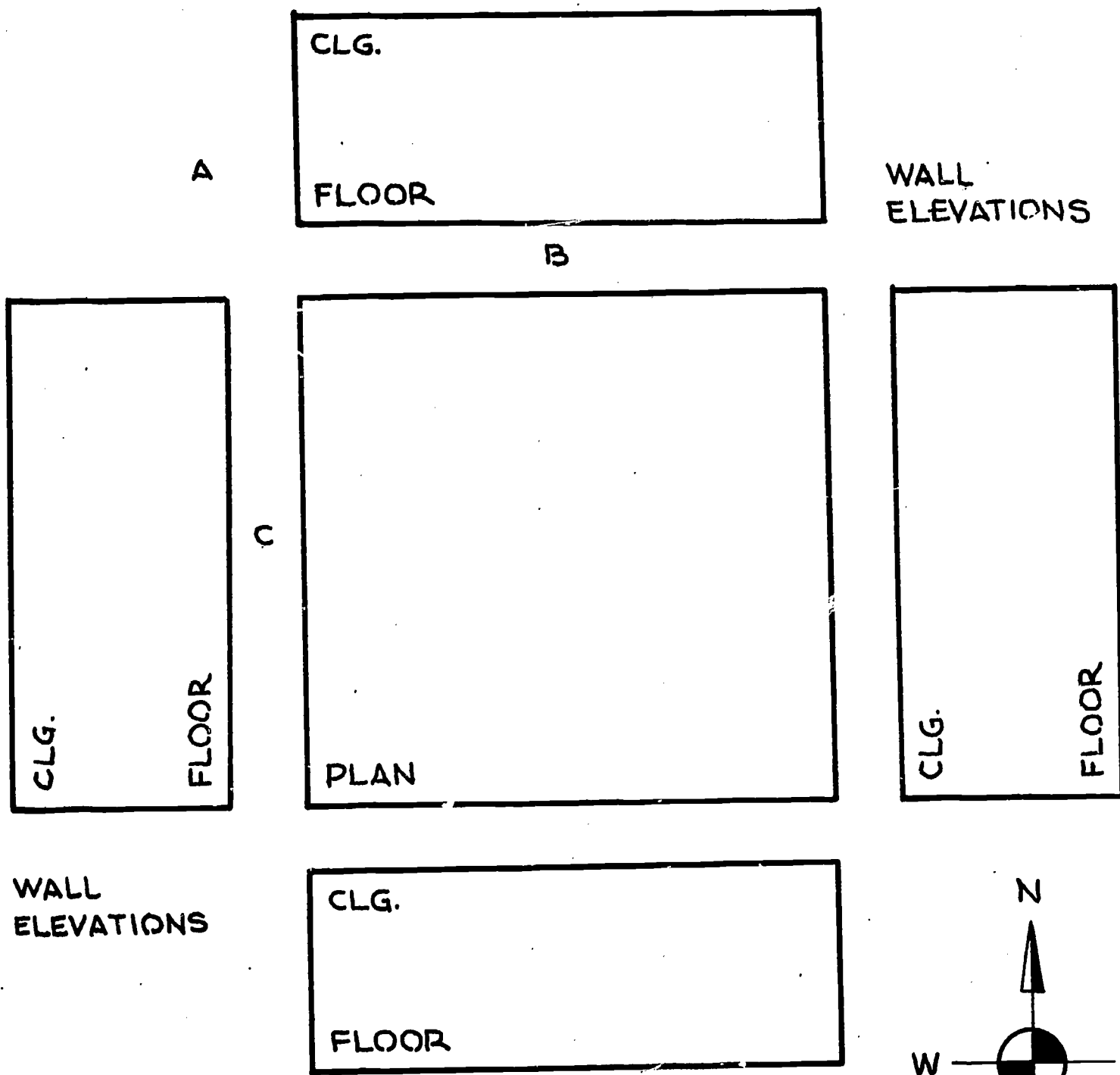

**FLOOR & WALL PLANS**

- (a) On room floor plan and wall layout indicate and note all items which you stated were present by your Yes answer to questions (a) through (g) of preceding page.
- (b) Indicate Doors  
on Plan & Elevations
- (c) Indicate Approximate Dimensions
  - 1. Ceiling Height \_\_\_\_\_
  - 2. Room Width \_\_\_\_\_
  - 3. Room Length \_\_\_\_\_

SONIC ENVIRONMENT EVALUATION QUESTIONNAIRE

DISTRICT ADMINISTRATOR QUESTIONNAIRE

School: \_\_\_\_\_

Location: \_\_\_\_\_

Date: \_\_\_\_\_ Time of Day: \_\_\_\_\_

Title of Administrator: \_\_\_\_\_

What is the most needed improvement concerning acoustical conditions?  
\_\_\_\_\_  
\_\_\_\_\_

Has there been any critical comment from your teaching staff about acoustical conditions in this school?  
\_\_\_\_\_  
\_\_\_\_\_

Has there been any critical comment from teacher or staff regarding the room or rooms evaluated?  
\_\_\_\_\_  
\_\_\_\_\_

What is your opinion of the acoustical environment in this school?  
\_\_\_\_\_  
\_\_\_\_\_  
\_\_\_\_\_  
\_\_\_\_\_

How do you rate this school building with regard to acoustics?

Excellent \_\_\_\_\_ Good \_\_\_\_\_ Satisfactory \_\_\_\_\_ Acceptable \_\_\_\_\_

Noc Acceptable \_\_\_\_\_

If the building rating is not acceptable, please list below a brief comment explaining the reason or reasons for this rating:  
\_\_\_\_\_  
\_\_\_\_\_

Comments:  
\_\_\_\_\_  
\_\_\_\_\_  
\_\_\_\_\_



**STUDENT QUESTIONNAIRE**

School: \_\_\_\_\_

Room: \_\_\_\_\_

Date: \_\_\_\_\_ Time of Day: \_\_\_\_\_

Subject: \_\_\_\_\_

Can you easily hear the words of your instructor? \_\_\_\_\_

Generally is there too much noise in this room? \_\_\_\_\_

If so, what kind of noise? \_\_\_\_\_

Do exterior noises interfere with your work in the classroom:

Radio _____	TV _____
Record Player _____	Traffic _____
Speech _____	Planes _____

What acoustic improvement of any kind does this room most need? \_\_\_\_\_

\_\_\_\_\_  
\_\_\_\_\_  
\_\_\_\_\_

CLASSROOM TEACHER QUESTIONNAIRE

School: \_\_\_\_\_

Room: \_\_\_\_\_

Date: \_\_\_\_\_ Time of Day: \_\_\_\_\_

Subject Taught: \_\_\_\_\_ Age group of students: \_\_\_\_\_

How many students are in this class: \_\_\_\_\_

Is the room satisfactory acoustically for recitation, conference, study, and audio visual presentations? \_\_\_\_\_

Is it hard for you to speak normally and make yourself heard by the students? \_\_\_\_\_

Is it hard for you to hear the speech of the students or others in the room? \_\_\_\_\_

Are there any distracting noises? \_\_\_\_\_

What kind of noises in the room bother you? \_\_\_\_\_

Do exterior noises interfere with your work, such as:

Radio \_\_\_\_\_ TV \_\_\_\_\_

Record Player \_\_\_\_\_ Work \_\_\_\_\_

Speech \_\_\_\_\_ Planes \_\_\_\_\_

Traffic \_\_\_\_\_ Power Mowers \_\_\_\_\_

Other \_\_\_\_\_

Are there distracting noises from mechanical equipment? \_\_\_\_\_

What improvement of any kind does this room need? \_\_\_\_\_

Comments: \_\_\_\_\_

MUSIC TEACHER QUESTIONNAIRE

School: \_\_\_\_\_

Room: \_\_\_\_\_

Date: \_\_\_\_\_ Time of Day: \_\_\_\_\_

Is the room satisfactory for a band? \_\_\_\_\_

Is the room satisfactory for an orchestra? \_\_\_\_\_

Is the room satisfactory for a choral group? \_\_\_\_\_

Is there interference from sounds outside the room? \_\_\_\_\_

What kind of sounds? \_\_\_\_\_

Is there interference from sounds inside the room? \_\_\_\_\_

What kind of sounds? \_\_\_\_\_

Do you perceive accurately the separate sounds of instruments (voices)  
in group music? \_\_\_\_\_

What acoustic improvement of any kind does this room need? \_\_\_\_\_

Comments: \_\_\_\_\_

MULTI-USE BUILDING QUESTIONNAIRE FOR

THE PRINCIPAL

What is the seating capacity of the room for assembly? \_\_\_\_\_

What is the seating capacity of the room for dining? \_\_\_\_\_

Is the room comfortable from a noise standpoint when groups are eating?  
\_\_\_\_\_

Are hearing conditions good when music is performed for an audience? \_\_\_\_\_  
\_\_\_\_\_

(a) Nearly empty \_\_\_\_\_

(b) Occupied to half capacity \_\_\_\_\_

(c) At full capacity \_\_\_\_\_

Is speech clearly understandable when the room is:

(a) Nearly empty \_\_\_\_\_

(b) Occupied to half capacity \_\_\_\_\_

(c) At full capacity \_\_\_\_\_

Do you need amplification (sound reinforcement) in room? \_\_\_\_\_  
\_\_\_\_\_

Is sound of mechanical equipment distracting in the room? \_\_\_\_\_  
\_\_\_\_\_

Is there other sound interference? \_\_\_\_\_  
\_\_\_\_\_

What acoustical improvement of any kind does this room need? \_\_\_\_\_  
\_\_\_\_\_

Comments: \_\_\_\_\_  
\_\_\_\_\_  
\_\_\_\_\_