

R E P O R T R E S U M E S

ED 014 215

EM 000 498

ARITHMETIC DRILLS AND REVIEW ON A COMPUTER-BASED TELETYPE.

BY- SUPPES, PATRICK AND OTHERS

STANFORD UNIV., CALIF., INST.MATH.STUDIES SOC.SCI.

REPORT NUMBER PSYCHOL-SER-TR-83

PUB DATE 5 NOV 65

EDRS PRICE MF-\$0.25 HC-\$0.76 17P.

DESCRIPTORS- *ARITHMETIC, *TEACHING MACHINES, *FEEDBACK,
*TESTS OF SIGNIFICANCE, *PROBLEM SETS, GRANT SCHOOL,
CUPERTINO SCHOOL DISTRICT, CALIFORNIA

FIFTEEN DAILY DRILLS EMPHASIZING MASTERY OF BASIC NUMBER FACTS, SUCH AS ARITHMETIC OPERATIONS AND UNITS OF MEASUREMENT WERE CONSTRUCTED TO ENCOMPASS 7 PREVIOUSLY REPORTED ATTRIBUTES OF AN EFFECTIVE DRILL. ATTRIBUTES ARE MIXED DRILL, TIME LIMIT, INCREASINGLY DIFFICULT EXAMPLES, THOROUGH COVERAGE, FREQUENT AND SMALL AMOUNTS, VERBAL PROBLEMS, DIAGNOSIS FACILITATION. SHORT DRILLS AVERAGING 20 PROBLEMS REACHED THE 41 GRADE 4 PUPILS (AVERAGE IQ WAS 130) VIA A COMMERCIALY AVAILABLE TELETYPE CONNECTED FROM THEIR CLASSROOM TO A STANFORD UNIVERSITY COMPUTER. LITTLE TEACHER PREPARATION WAS REQUIRED. WITH IMMEDIATE FEEDBACK AND A 10-SECOND TIME LIMIT PER RESPONSE, EACH STUDENT HAD 2 CHANCES TO ANSWER CORRECTLY. RANKING THE LESSONS BY PROPORTION OF CORRECT RESPONSES AND CLASSIFYING THEM BY TYPE OF PROBLEM SHOWED THAT LESSONS OF THE SAME TYPE TEND TO BE GROUPED IN ADJACENT RANKS. AMOUNT OF PREVIOUS PRACTICE, AND NUMBER OF PUPILS TAKING EACH LESSON CONFOUND THIS RELATIONSHIP, HOWEVER. THE RANK-ORDER CORRELATION BETWEEN THE AVERAGE PROPORTION OF ERRORS AND THE TIME TAKEN TO COMPLETE A LESSON WAS STATISTICALLY SIGNIFICANT. A COMPARISON OF 5 INDIVIDUAL STUDENTS ALSO SHOWS THIS RELATIONSHIP. DATA REPORTED HERE WERE INTENDED TO GIVE ONLY A SENSE OF METHODS FOR MORE RIGOROUS CLASSROOM EXPERIMENTATION. FUTURE EXPANSION OF THE PROJECT CALLS FOR 80 STUDENTS USING EACH OF 3 TELETYPES EVERY DAY, MORE EXTENSIVE REPORTS TO STUDENTS AND TEACHERS, PROGRAM BRANCHING CAPABILITIES. (LH)

ARITHMETIC DRILLS AND REVIEW ON A

U.S. DEPARTMENT OF HEALTH, EDUCATION & WELFARE
OFFICE OF EDUCATION

COMPUTER-BASED TELETYPE

by

DOCUMENT HAS BEEN REPRODUCED EXACTLY AS RECEIVED FROM THE
PERSON OR ORGANIZATION ORIGINATING IT. POINTS OF VIEW OR OPINIONS
STATED DO NOT NECESSARILY REPRESENT OFFICIAL OFFICE OF EDUCATION
POSITION OR POLICY.

Patrick Suppes, Max Jerman,
and Guy Groen

TECHNICAL REPORT NO. 83

November 5, 1965

PSYCHOLOGY SERIES

Reproduction in Whole or in Part is Permitted for
any Purpose of the United States Government

INSTITUTE FOR MATHEMATICAL STUDIES IN THE SOCIAL SCIENCES

STANFORD UNIVERSITY

STANFORD, CALIFORNIA

ED014215

EM 000 498

Arithmetic Drills and Review on a

Computer-based Teletype*

Patrick Suppes, Max Jerman, and Guy Groen

Given a computer-based instructional program, and a school in which to work; it is possible to supplement or enrich the teacher's instruction by either taking over the more routine daily tasks, presenting special materials, or the daily lesson itself. The task of the present project was to prepare a program in arithmetic to review and teach the basic number facts supplementing the teacher's daily instruction at the fourth-grade level. In addition, the project was concerned with gaining a clearer picture of what the optimum teacher-machine interaction pattern should be in order to take full advantage of both.

Objectives

One of the primary objectives was to review and teach the basic number facts which comprise an important part of a fourth-grade mathematics program. Often those engaged in teaching "modern mathematics" play down this part of the curriculum. Stressing fundamental concepts and structure is essential, but mastery of the basic facts should not be neglected.

*This research has been supported by the National Science Foundation and the Carnegie Corporation of New York. We are much indebted for the cooperation of Mr. Victor Norton, the principal of the school, and Mrs. Fran Emery, teacher of the fourth-grade class in Grant School, Cupertino School District, in which this study was conducted.

In working out a continuous daily program, sequencing of material and providing a proper amount of review, so as to correlate with the day-to-day classroom instruction, become practical objectives. In our case both level of difficulty and length of exercise directly affected the running time for each student, which had to be sufficiently short to permit each student in the class an opportunity to perform on the machine during the regular school day.

To our knowledge no elementary-school teacher has had a computer-based teaching device available to her on a daily basis up to this time. The mechanics of having each child take his turn during the day without disrupting the regular work of the class was of some concern. Related to this problem was concern over the ability of a teacher untrained in the use of the machine or its operation to adjust to its presence in the room and to use it optimally. From previous experience in observing young children operate the teaching machines in Stanford's Computer-Based Instruction Laboratory it was believed that there would be little or no problem in the children's adjusting to the machine. (This assumption was correct; most students were very quick to master the simple operations required.)

Related Research

Programmed Instruction. Reports of extensive research over long periods of time are lacking. While some creditable work has been done in the areas of branching and feedback variables, few studies using computer-based teaching devices are available. Most reported studies may be summarized by saying that students using well-written programmed materials, whether in a text or machine-like device, will be able to master some material as well as students in a regular class in somewhat less time.

Drill in Arithmetic. Some confusion still exists in the minds of many people concerning the use of drill in today's curriculum. Brownell (1929) as well as many others, has pointed out the need for well-planned drill in commenting on readiness for division by stating "If children find the topics hard, many times it is due to inadequate mastery of the skills and basic facts needed." Some years ago Busswell (1927) reported finding that 93 percent of the errors in long division made by fourth-, fifth- and sixth-grade pupils was due to a lack of mastery of number facts rather than number processes. Spencer (1929) maintained that there are indeed "typical errors in arithmetic accounting for 75 percent of all the errors in addition, 80 percent of the errors in subtraction, 50 percent of the errors in multiplication, and 70 percent of the errors in division."

The dangers of teaching by drill methods alone were pointed out in a later study by Brownell and Chazel (1960). It was emphasized that effective teaching must precede drill, if the drill is to have the desired results. It seems apparent on the basis of the foregoing that drills can most effectively be used to overcome the large percentage of typical errors in arithmetic after an introduction to the subject has been given. Also, a student should be given an opportunity to correct errors he makes in his daily work. Suppes and Ginsberg (1962) found that young children required to make an overt correction response after an incorrect response performed significantly better than a noncorrection group on a concept-formation task.

After studying a large number of reports on drill methods, Wilson (1925) concluded that to be effective a drill should have the following attributes.

1. It should be on the entire process.
2. It should come frequently in small amounts.
3. Each unit should be a mixed drill.
4. It should have a time limit.
5. Examples in a drill should be in order of difficulty.
6. Drills should include verbal problems.
7. Drills should facilitate diagnosis.

Procedure

The Machine and the Classroom. The teaching machine used in this project was a commercially available teletype, connected by private phone line to the computer in Stanford's Laboratory. A large book closet, which opened into the classroom, was modified by adding a ventilation fan, light, and electrical outlet. This provided privacy for the user and insulated the rest of the class from the operational noise of the teletype. With these very minor modifications, the closet provided an excellent teaching station throughout the day.

The Instructional Program. Instruction on the machine began in the spring of 1965, running for seven consecutive weeks. The daily drills were constructed on the principles of the above-mentioned research, particularly in terms of the attributes listed by Wilson. Each drill was short, 3 to 6 minutes, varying from 5 to 30 problems (with an average of 20).

As each student took his turn, the machine printed out "please type your name." The student spelled his name by typing, using the hunt-and-peck method for the most part. If his name was incorrectly spelled, he was informed "This name is not on the student list, try again. Please type your name." A proper entry set the program in operation and the first problem was printed out, leaving a blank for the correct response. The machine was programmed to position itself at the blank so as to have the response properly placed. A correct response was reinforced by the appearance of the next problem. An incorrect response was indicated by the word "wrong" being typed out and the problem itself being repeated. A second error on the same problem was followed by the message "wrong, the answer is __," the correct answer being displayed. The problem itself was then given once more to allow for a correction response. An error on the correction response would cause the previous message to reappear. The next problem would then be presented. A 10-second time limit per response was set. If a response was not given before 10 seconds

the machine response followed the above pattern except that the words "time is up" were substituted for "wrong" at each step. The sequence of events is presented in Figure 1 below.

Insert Fig. 1 about here

When the lesson was completed, the machine printed out for the student the following: total errors (giving the number of errors), problems missed (giving the number of each problem on which an error or time-out was made), and total elapsed time in seconds. Following this information it then typed "tear off here _ _ _ _ _" and turned the paper up to the cutter bar permitting the student to tear off and keep the printed record of his day's work.

At the end of the day or when all the children had finished the teacher typed the word "finished." The computer program then gave her (1) the number of students who made time-outs and errors on each problem in the lesson; (2) the distribution of error for the entire class, i.e., the number of students making 0, 1, 2, etc., errors and time-outs, and; (3) the distribution of the total elapsed time, by 30 second intervals for the class.

Teacher Preparation. Little teacher preparation was required. A simple dial-in code was all that was needed to call up each day's lesson. The code, consisting of ten steps, was posted on the machine for the teacher to follow.

The Class. The class consisted of 41 fourth-grade pupils. Their average IQ on the CTMM was 130. They adapted very quickly to the machine. There were few, if any, problems after the second day with either the machine operation or finding the right key.

Supervision. One project staff member was either present or on call by phone at all times. Constant attention was required at the beginning of the experiment. However, the number of breaking-in problems

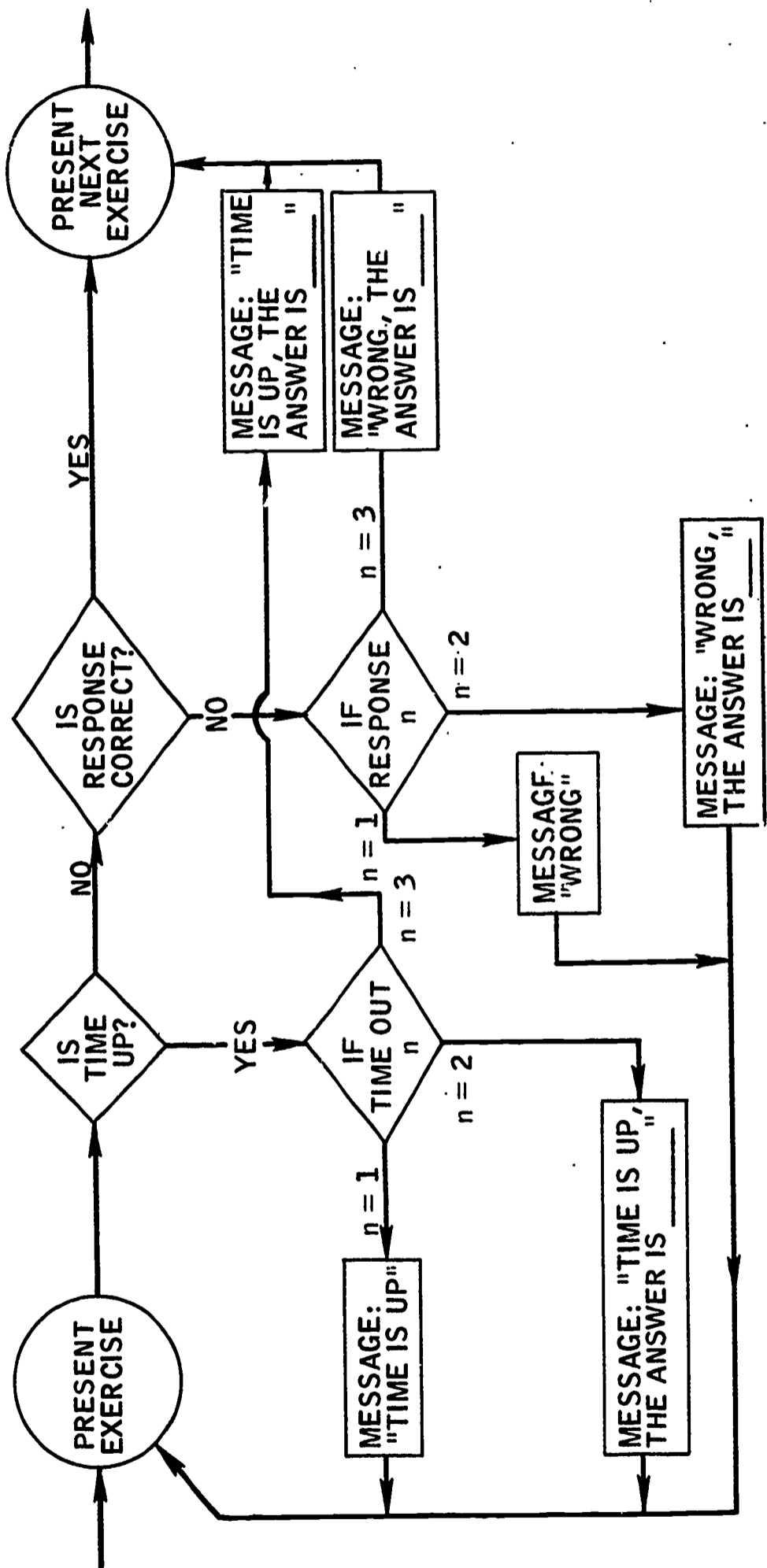

Figure 1. Flow Chart of the Program Logic for Computer-based Instruction in the Fundamentals of Arithmetic.c

of the new operation soon diminished and after the first three weeks the teacher controlled the daily operation alone, without difficulty.

Lesson Content. The data presented in this paper are based on 15 lessons. Prior to these 15 lessons, each student had been given 2 practice lessons in order to make him familiar with the equipment.

Lesson 1 contained problems of the form $(6 \times 7) + 3 = \underline{\quad}$, $(57 - 3) \div 6 = \underline{\quad}$, and three problems of the form $53 - 4 = 7 \times \underline{\quad}$. Lesson 2 concentrated on problems of the form $(8 \times 6) - 6 = 6 \times \underline{\quad}$ and $(7 \times 5) + 5 = 4 \times \underline{\quad}$. Lesson 3 was on units of measure containing items such as 1 quart = $\underline{\quad}$ pints, 1 mile = $\underline{\quad}$ feet, and 2 yds. + 5 ft. = 3 yds. and $\underline{\quad}$ ft. Lesson 4 contained such problems as $(4 \times 3) \times 3 = \underline{\quad}$, $147 \times 4,352 = 4,352 \times \underline{\quad}$, and $3 \times (4 + 7) = (3 \times 4) + (3 \times \underline{\quad})$. Beginning with Lesson 5, the problems were of a simpler form. Lessons 5, 6, and 7 were on the multiplication tables for 8, 9, and 10. Each problem had the general form $a \times b = \underline{\quad}$. Lesson 8 was a mixed drill using the operations of addition, subtraction, multiplication, and division. Lessons 9 and 10 concentrated on multiplication by 10 and 100. Lesson 11 consisted of 5-word problems. This was the first time the children had been exposed to word problems on the teletype. One of the problems asked students to find distance, given rate and time; two problems required simple mental division; one was a simple subtraction problem involving money; and the other was an addition problem concerned with tickets to a school play. Lessons 12, 13, and 14 were mixed drills containing a large proportion of simple multiplication problems. Lesson 15 was another drill on units of measurement.

Findings

The data obtained from this procedure were summarized on the basis of the first answer given by the pupil. If his answer was wrong or timed out it was regarded as such, regardless of the response he made

on his second attempt at the problem. Our main reason for distinguishing between errors and time-outs was that if a pupil was timed out, it was clear that he had not completed the problem in the allotted time, but uncertain whether or not he would have subsequently made an error, had he been given more time.

For each lesson, the average proportions of errors, successes and time-outs were computed. The result of this computation is shown in Fig. 2. Since the drills varied considerably in the type of problem

Insert Fig. 2 about here

that predominated, this graph is hard to interpret. About all that can be said is that there is a tendency for the proportion of successes to increase, although there are many obvious exceptions. Owing to this somewhat serious confounding between time and lesson-type, a more meaningful comparison can be made by rank ordering the lessons in terms of proportion of correct responses and classifying them in terms of predominant type of problem. The result of an analysis of this type is shown in Table 1. In this Table, the predominant form is defined as the

Insert Table 1 about here

form of at least three-quarters of the problems in a given lesson. The symbols o and o' denote arbitrary but distinct operations.

It would appear from this Table that the difficulty of a lesson is related to the type and predominant form of the problems in the lesson. The extent to which the difficulty of a lesson is related to the amount of previous practice is impossible to determine. It should be noted that, in addition to the problem of differing lesson types, any sequential analysis is certain to be confounded by the fact that the number of pupils that took each lesson varied. This can be seen by comparing Lessons 3 and 15. The two are of the same type, but do not differ in difficulty (as measured by proportion of correct responses), despite the fact that one was presented on the third day and the other

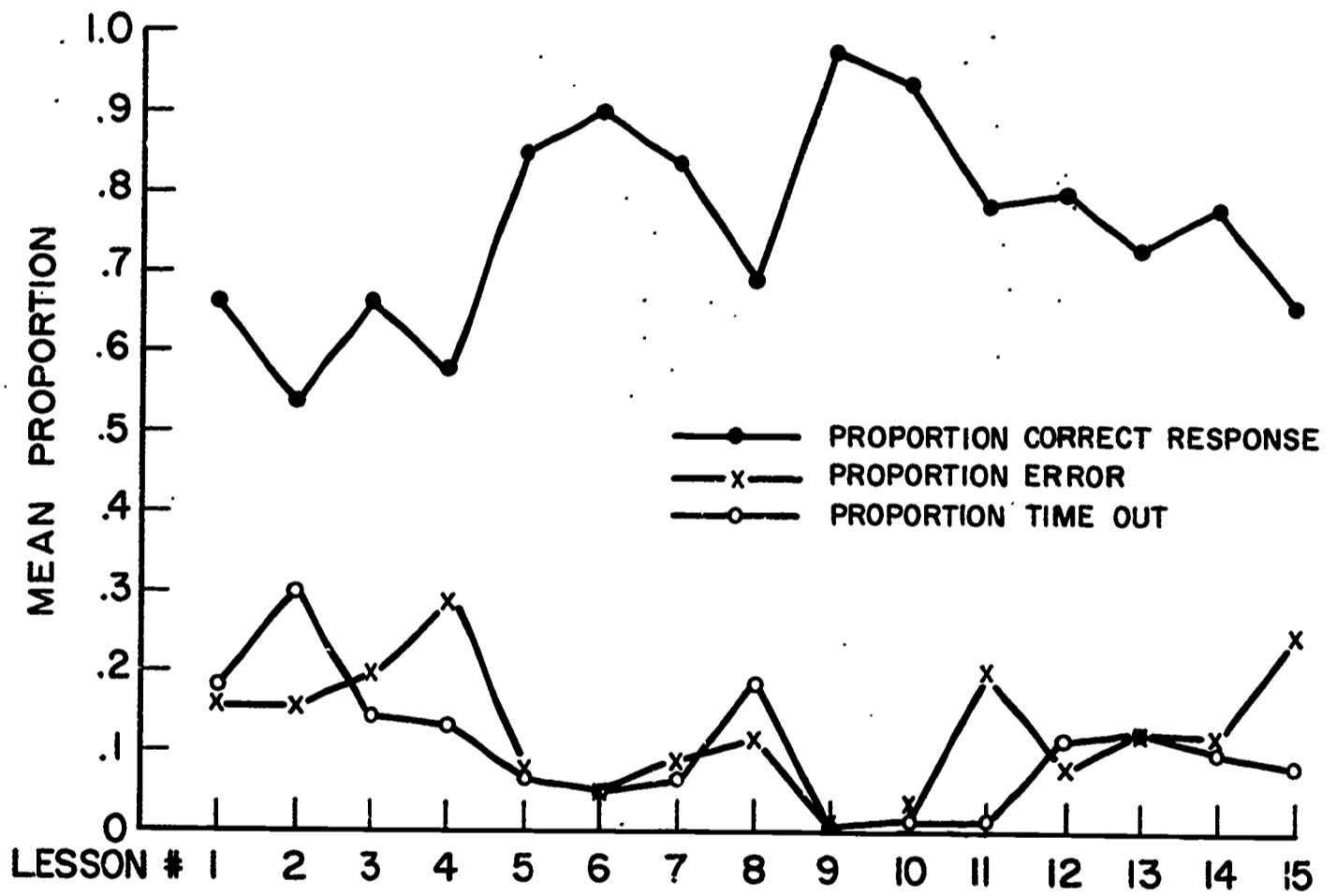

Figure 2. Probability of Response Per Pupil on 15 Lessons

Table 1. Rank order of lessons according to mean probability of a correct response.

Rank	Lesson	Type	Predominant Form	Number of Subjects	Proportion of Successes
1	2	Mixed	$(a \ o \ b) \ o' \ c = d \times _$	22	.54
2	4	Mixed	$(a \ o \ b) \ o' \ c = _$	39	.58
3	1	Mixed	$(a \ o \ b) \ o' \ c = _$	23	.66
	3	Units of Measure		19	.66
	15	Units of Measure		39	.66
6	8	Mixed		36	.69
7	13	Mixed	$a \times b = _$	33	.73
8	11	Word		39	.78
	14	Mixed		38	.78
10	12	Mixed	$a \times b = _$	36	.80
11	7	Multn	$a \times b = _, a = 8, 9, 10$	39	.84
12	5	Multn	$a \times b = _, a = 8, 9, 10$	40	.85
13	6	Multn	$a \times b = _, a = 10, 100$	24	.90
14	10	Multn	$a \times b = _, a = 10, 100$	39	.94
15	9	Multn	$a \times b = _, a = 10, 100$	39	.98

Feasibility of the System

Teacher Reaction. Although only one classroom teacher was directly involved in this project, her reaction to this project and the machine was very encouraging. She remained enthusiastic throughout the seven weeks the project was in operation. For example, she made it possible to extend the running time through the morning recess or lunch hour on days when drills were difficult so that every student could participate. She discussed, with individual students, errors on their print outs and sometimes modified her instruction to handle problems of general concern to the class.

Limitations Imposed by the System on the Class and Curriculum. Time was an important factor in daily operations during the project. The originally planned 4-minute allotment for each student was difficult to maintain. Frequently students would run over the planned time, causing the day's run to extend through the lunch hour and into the afternoon. Length and difficulty of each lesson were the major factors. Delay between students increased total running time in some cases. Generally, however, there was little delay between students due to good management by the classroom teacher.

The lesson material itself was limited to the characters available on a standard typewriter. This was not a severely limiting factor, however, due to the type of material used in the project. Special print wheels with more mathematical symbols will be available for next year, greatly increasing the flexibility of the system. The material was presented in linear form, requiring every student to do the same lesson each day. The possibility of branching to either more or less difficult material based on performance was not available. This feature will be part of next year's program.

System Operation. The major source of system failures or operational delays was in Stanford's Laboratory itself. Failure to maintain priority

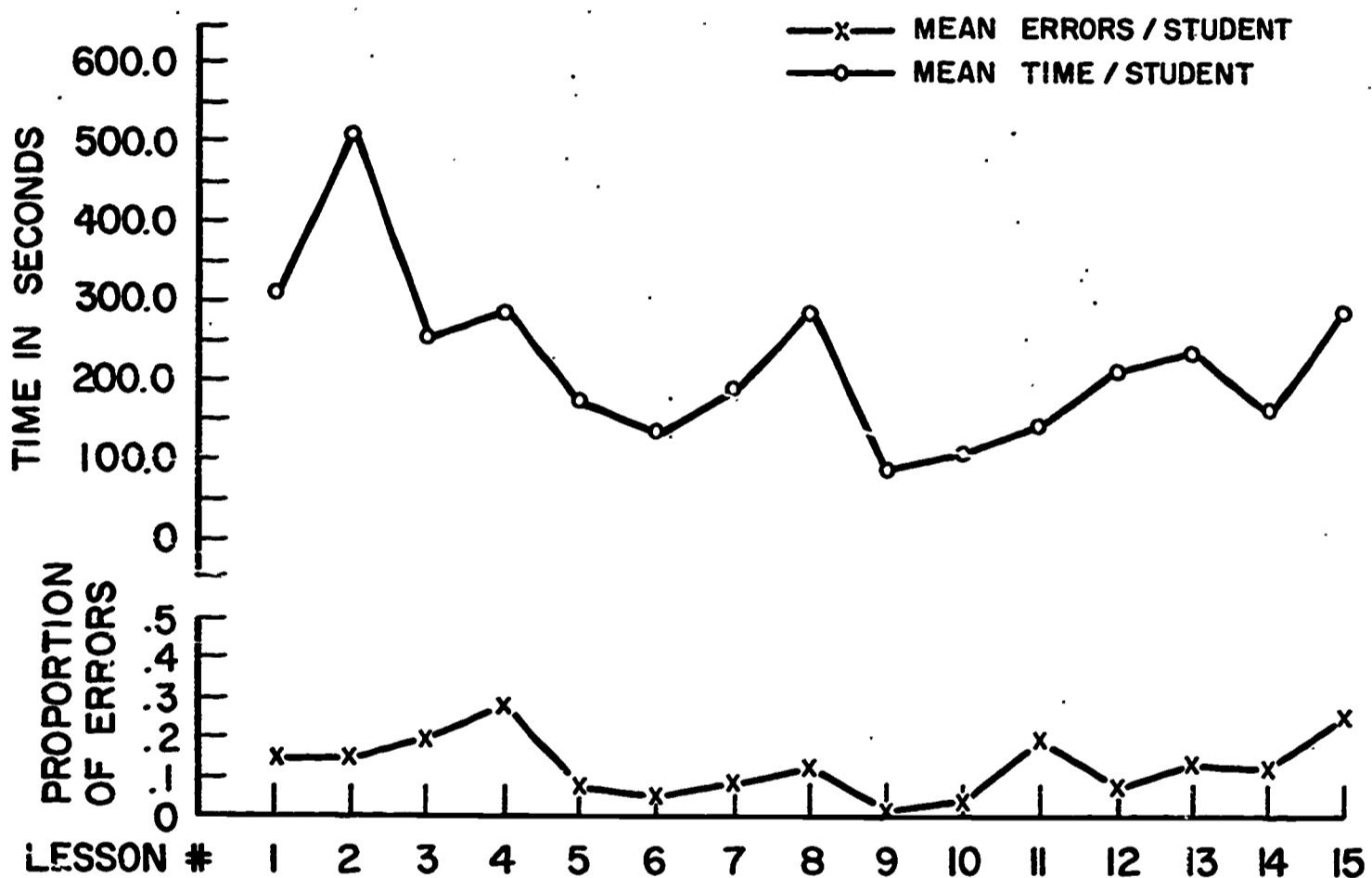

Figure 3. Mean Completion Time and Mean Proportion of Errors Per Lesson

Table 2. Individual differences between selected students.

Pupil	Total Time to Complete Drill (in seconds)			Mean Proportion Wrong	Mean Proportion Correct
	Minimum	Maximum	Average		
1	95	233	135	.06	.92
2	87	263	161	.07	.89
3	101	358	194	.11	.83
4	95	747	328	.15	.57
5	103	802	348	.15	.52

Feasibility of the System

Teacher Reaction. Although only one classroom teacher was directly involved in this project, her reaction to this project and the machine was very encouraging. She remained enthusiastic throughout the seven weeks the project was in operation. For example, she made it possible to extend the running time through the morning recess or lunch hour on days when drills were difficult so that every student could participate. She discussed, with individual students, errors on their print outs and sometimes modified her instruction to handle problems of general concern to the class.

Limitations Imposed by the System on the Class and Curriculum. Time was an important factor in daily operations during the project. The originally planned 4-minute allotment for each student was difficult to maintain. Frequently students would run over the planned time, causing the day's run to extend through the lunch hour and into the afternoon. Length and difficulty of each lesson were the major factors. Delay between students increased total running time in some cases. Generally, however, there was little delay between students due to good management by the classroom teacher.

The lesson material itself was limited to the characters available on a standard typewriter. This was not a severely limiting factor, however, due to the type of material used in the project. Special print wheels with more mathematical symbols will be available for next year, greatly increasing the flexibility of the system. The material was presented in linear form, requiring every student to do the same lesson each day. The possibility of branching to either more or less difficult material based on performance was not available. This feature will be part of next year's program.

System Operation. The major source of system failures or operational delays was in Stanford's Laboratory itself. Failure to maintain priority

to access memory in storage accounted for several three- to five-minute delays. Computer component failures accounted for 80 percent of the time lost. One day was lost due to a telephone-line transmission problem. Reliability is expected to improve as the system completes its "breaking-in" phase.

Possibilities for Controlled Classroom Experimentation. A system, such as the one used in the project, provides an opportunity for controlled classroom experimentation. In many ways it resembles a psychological laboratory in providing the possibility of establishing strict control over many variables. The data reported in the present report represent a very superficial beginning and are intended only to give a sense of the methods and procedures that may be used for extensive pedagogical and psychological investigation of arithmetic skills.

Future Curriculum Plans

The project will be expanded during 1965-66. Three teletypes on a full-time basis will be used, one each in grades 4, 5, and 6. Arrangements are being made at the school to allow easy access, for 80 students a day, to each machine. Data analysis and lesson programs are being improved to provide more extensive reports to students and teachers as well as branching capabilities based on student performance. Each student may be given one of five lessons each day depending on his performance on the previous day. The five possible lessons vary widely in difficulty, the aim being to provide a "floor" for the poor learners and a very high "ceiling" for the fast learners. The complete program and lesson assignment will be automatic, all necessary information being held in the computer bulk memory storage.

References

1. Brownell, William A., "Arithmetic Readiness as a Practical Classroom Concept," Elementary School Journal, 1952, 52, 15-22.
2. Brownell, William A., and Charolette B. Chazel, "Premature Drill," in Research in the Three R's, C. W. Hunicutt and W. J. Iverson, Editors, New York, Harper and Brothers, 1960.
3. Buswell, Guy T., Summary of Arithmetic Investigations (1927), Chicago, University of Chicago Press, 1928.
4. Spencer, Peter L., "A Study of Arithmetic Errors," Unpublished Ph.D. Dissertation, Stanford University, 1929.
5. Suppes, P., and Rose Ginsberg, "Application of a Stimulus Sampling Model to Children's Concept Formation With and Without Overt Correction Responses," Journal of Experimental Psychology, 1962, 63, 330-336.
6. Wilson, Guy M., "Arithmetic," Research in Constructing the Elementary School Curriculum, Third Yearbook of the Department of Superintendence, Washington, D. C., N.E.A., 1925.