

R E P O R T R E S U M E S

ED 010 563

56

SYSTEM DESIGN FOR A CONTINUOUS PROGRESS SCHOOL--PART III, THE INSTRUCTIONAL MATERIALS CENTER.

BY- EGBERT, ROBERT L. COGSWELL, JOHN F. SYSTEM DEVELOPMENT CORP., SANTA MONICA, CALIF.

REPORT NUMBER NDEA-VIIA-1130-06

PUB DATE 1 AUG 64

REPORT NUMBER BR-5-0738-06

REPORT NUMBER TM-1493/105/00

GRANT OEG-7-14-9120-217

EDRS PRICE MF-\$0.09 HC-\$0.92 23P.

DESCRIPTORS- \*PROGRAMED INSTRUCTION, PROGRAM ADMINISTRATION, PROGRAM DEVELOPMENT, STUDENT EVALUATION, STUDENT TEACHER RELATIONSHIP, ACADEMIC ACHIEVEMENT, STUDENT PROBLEMS, STUDENT RECORDS, \*EXPERIMENTAL SCHOOLS, EXPERIMENTAL PROGRAMS, \*EXPERIMENTAL CURRICULUM, \*INSTRUCTIONAL MATERIALS CENTER, INSTRUCTIONAL MATERIALS, LIBRARIES, \*SYSTEMS ANALYSIS, MATERIAL DEVELOPMENT, SANTA MONICA, CALIFORNIA, CONTINUOUS PROGRESS PLAN SCHOOLS, PROVO UTAH, BRIGHAM YOUNG UNIVERSITY

THE INSTRUCTIONAL MATERIALS CENTER (IMC) OF THE CONTINUOUS PROGRESS SCHOOL WAS DESCRIBED. THE CONTINUOUS PROGRESS SCHOOL PLAN WAS DEVISED BY DR. EDWIN READ AND WAS BEING DEVELOPED AT THE LABORATORY SCHOOL OF BRIGHAM YOUNG UNIVERSITY. THIS REPORT DESCRIBED HOW AN IMC MIGHT OPERATE RATHER THAN HOW ONE IS OPERATING OR IS PLANNED TO OPERATE. AS CONCEIVED, THE IMC COMBINED THE FUNCTIONS OF THE LIBRARY, THE BOOK STORE, THE AUDIOVISUAL CENTER, AND THE DEVELOPMENT OF MATERIALS. FLOW DIAGRAMS OF THE PLANNED OPERATION WERE INCLUDED. RELATED REPORTS ARE ED 010 561, THROUGH ED 010 564. (AL)

ED010563

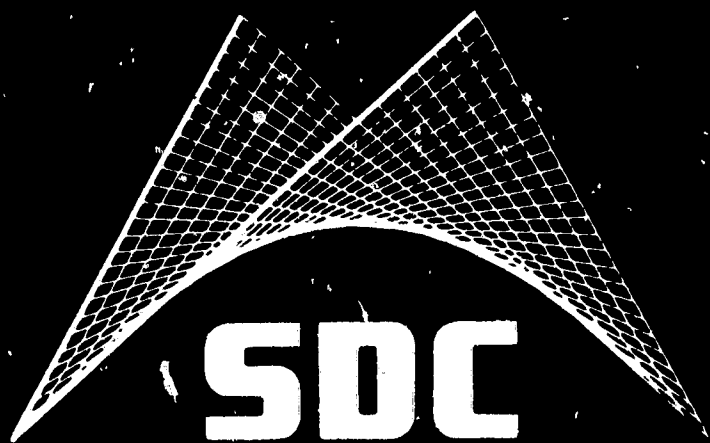

**TM-1493/105/00**

**System Design for a Continuous Progress School:**

**Part III The Instructional Materials Center**

**1 August 1964**

U. S. DEPARTMENT OF HEALTH, EDUCATION AND WELFARE  
Office of Education

TM-1493/105/00

This document has been reproduced exactly as received from the person or organization originating it. Points of view or opinions stated do not necessarily represent official Office of Education position or policy.

# TECHNICAL MEMORANDUM

(TM Series)

The research reported herein was conducted under SDC's independent research program and Grant 7-14-9120-217, U. S. Department of Health, Education, and Welfare, Office of Education.

---

System Design for a Continuous Progress School:  
Part III - The Instructional Materials Center

by

Robert L. Egbert and John F. Cogswell  
1 August 1964  
(Principal Investigator, David G. Ryans)

Title VII of P.L. 85-864  
National Defense Education Act of 1958  
Grant 7-14-9120-217

SYSTEM

DEVELOPMENT

CORPORATION

2500 COLORADO AVE.

SANTA MONICA

CALIFORNIA

---

The views, conclusions, or recommendations expressed in this document do not necessarily reflect the official views or policies of agencies of the United States Government.



Permission to quote from this document or to reproduce it, wholly or in part, should be obtained in advance from the System Development Corporation, or from authorized agencies of the U. S. Government.

© by the System Development Corporation, 1964

1 August 1964

1  
(page 2 blank)

TN-1493/105/00

TABLE OF CONTENTS

	<u>Page</u>
INTRODUCTION . . . . .	4
FUNCTIONS OF THE IMC . . . . .	5
Acquisition and Disposition of Purchasable Items . . . . .	5
Acquisition of New Books and Equipment for the IMC . . . . .	5
Circulation of Books . . . . .	11
Scheduling and Use of IMC Facilities . . . . .	15
SUMMARY . . . . .	19

LIST OF ILLUSTRATIONS

	<u>Page</u>
<u>Figure</u>	
1 ACQUISITION AND DISPOSITION OF PURCHASABLE ITEMS . . . . .	7
2 ACQUISITION OF NEW BOOKS AND EQUIPMENT FOR THE IMC . . . . .	9
3 CIRCULATION OF BOOKS . . . . .	13
4 SCHEDULING AND USE OF IMC FACILITIES . . . . .	17

PRECEDING PAGE BLANK-NOT FILMED

1 August 1964

3

TM-1493/105/00

**SYSTEM DESIGN FOR A CONTINUOUS PROGRESS SCHOOL: PART III**

**THE INSTRUCTIONAL MATERIALS CENTER**

**Robert L. Egbert  
Brigham Young University  
Consultant to System Development Corporation**

**John F. Cogswell  
System Development Corporation  
Santa Monica, California**

**PREFACE**

This is the third document in a series describing the Continuous Progress School, as designed and described by Dr. Edwin Read and his staff at Brigham Young University Laboratory School.

Although the Instructional Materials Center (IMC) is viewed as playing a central role in the Continuous Progress School and although it is the focus of much discussion, such a center is not in operation in a Continuous Progress School and no formal, descriptive documents have been prepared. For this reason, TM-1493/105/00 describes how an IMC might operate rather than how one is operating or is definitely planned to operate.

**ABSTRACT**

This document presents a design for the Instructional Materials Center (IMC) for a Continuous Progress School. The IMC, as conceived, combines the functions of the library, bookstore, audiovisual center, and materials development.

### INTRODUCTION

The Continuous Progress School, as designed and described by Dr. Edwin Read and his staff, presents a vastly different teaching learning program from the typical school of today. This different program is reflected in staff functioning, in general school organization, and in various auxiliary subsystems. One such auxiliary subsystem, the Surveillance and Detection System, has already been described (TM-1493/104/00). Another subsystem essential to the functioning of the Continuous Progress School is the Instructional Materials Center (IMC). Description of IMC operation is the purpose of this document.

In any good secondary school, many IMC functions are performed. The school library provides books, reference books, and periodicals; guidance in selection and use of these resources; and supervised study facilities. The audiovisual department provides equipment and materials for classroom use. The bookstore issues, receives, and repairs texts. And the industrial arts department may provide facilities where students can build small pieces of equipment, make charts, etc., for use in their courses. In the Continuous Progress School all of these functions and many additional activities, on a greatly increased scale, are performed in the IMC. Thus, the IMC becomes the center for much of the learning activity of the Continuous Progress School.

As has been indicated, many functions similar to those performed by the traditional library, the audiovisual department, and the bookstore are accomplished by the IMC in the Continuous Progress School. In some instances the functions are almost identical with those in a traditional school. For example, sale of school supplies must take place regardless of the school organization.

In other cases, the basic functions are similar, but the continuous progress nature of the school requires that these facilities be available when the individual student is ready, rather than at the same time for every student. An example of this is the issuing of texts and other course equipment and materials.

In still other instances, the basic nature of the function is different. An example of this is the use of audiovisual equipment. In a traditional school such equipment is circulated, on request, to the various classrooms. In the Continuous Progress School, in which the student rather than the class is the basic unit, either the student goes to a central area to use audiovisual equipment or his carrel is so constructed that he can have the tapes, films, etc., "piped" to him. Thus, these facilities typically are scheduled on student request rather than on faculty request.

1 August 1964

5  
(page 6 blank)

TM-1493/105/00

### FUNCTIONS OF THE IMC

In this section of TM-1493/105/00 a number of IMC functions are presented. While this list may not be inclusive, an attempt has been made to describe the operations in a manner sufficiently general that most kinds of anticipated activities can be covered. (The symbols and coding conventions in the flow charts are explained in TM-1493/103/00, page 8).

#### Acquisition and Disposition of Purchasable Items

In Figure 1 an account is given of the procedure for acquisition, handling, and selling of student-purchasable items. As is indicated in Figure 1, the stimulus to add a new item to the stock may come from one of several sources (X01). A student may wish (A02) and request (A04) an item not available at the IMC; a staff member may recognize the need for (A05) and request (A07) an item not previously required; or the IMC staff may receive information on sales in similar organizations or on newly available items (A08). Such information, regardless of the source, is evaluated (A09), and a decision is made on whether to stock the item (X10). If the item is considered important enough to carry (Q12), it is purchased in appropriate quantity (A12) and put on sale (A13). The sensing system then returns to its original condition (M1 to Q01). However, to answer other questions about purchasing aspects of the operation, the stock is also periodically examined (A15). If an item is moving slowly, the price may be reduced (A17); if it is moving well, a repurchase may be requested (A18). (This request would then be evaluated (A09) before a purchase was made.) From this stage the system either returns to its original condition (X19 to M1) or it may be terminated (A20).

In Figure 1 no attempt is made to depict the detailed operations of purchasing, selling, and accounting. Rather, a brief, generic description is given in order to provide a basis for considering this part of the CPS operation.

#### Acquisition of New Books and Equipment for the IMC.

Figure 2 shows the procedures followed in securing books and equipment for the IMC. As was true with student-purchasable items, the stimulus for securing books or equipment may come from any one of several sources (X01). Information on new items frequently is received by the school (A02). This information is evaluated against school needs (A03) and a decision made on whether the item would be useful (X04). If the staff gives a positive evaluation, a recommendation is made that the new article be purchased (A05).

As books and equipment are used, they are sometimes damaged or worn and should be replaced. Occasionally, also, demand for a specific book or piece of equipment far exceeds supply. In these instances, the IMC staff may recommend replacement or increase in circulating stock (A06).

1 August 1964

(page 7 blank)

TM-1493/105/00

PRECEDING PAGE BLANK-NOT FILMED

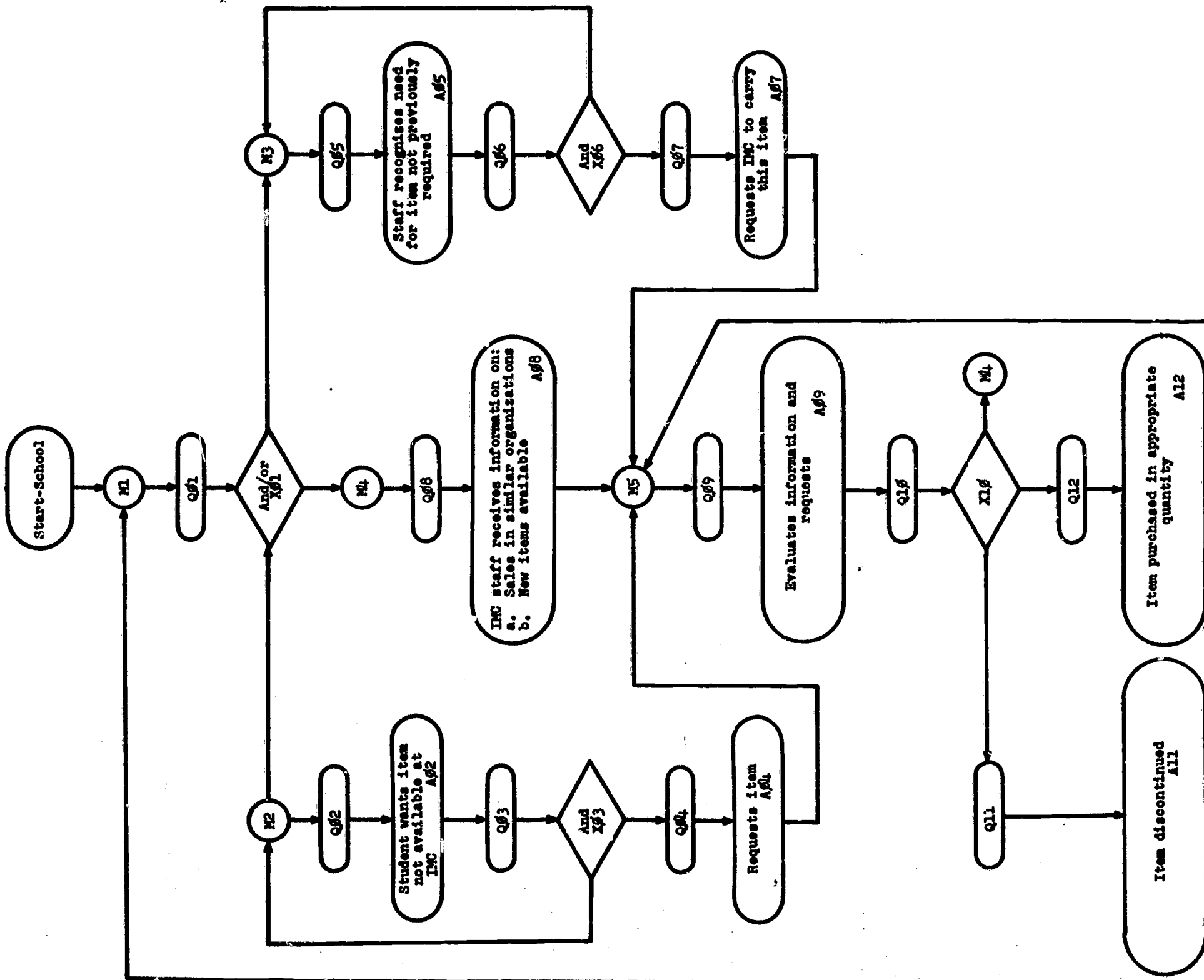
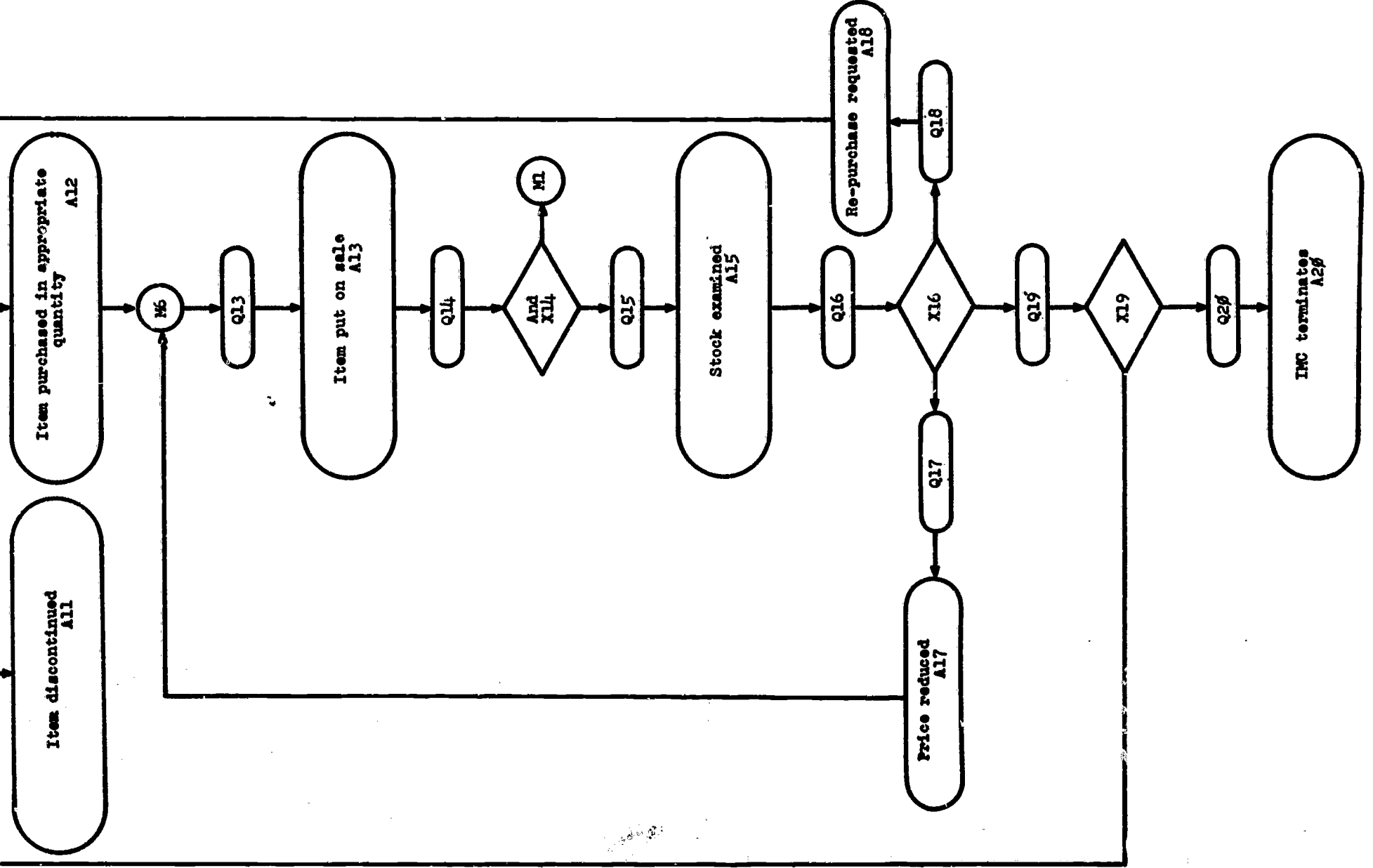

Figure 1. Acquisition and Disposition of Purchasable Items





1 August 1964

9  
(page 10 blank)

TM-1493/105/00

PRECEDING PAGE BLANK-NOT FILMED

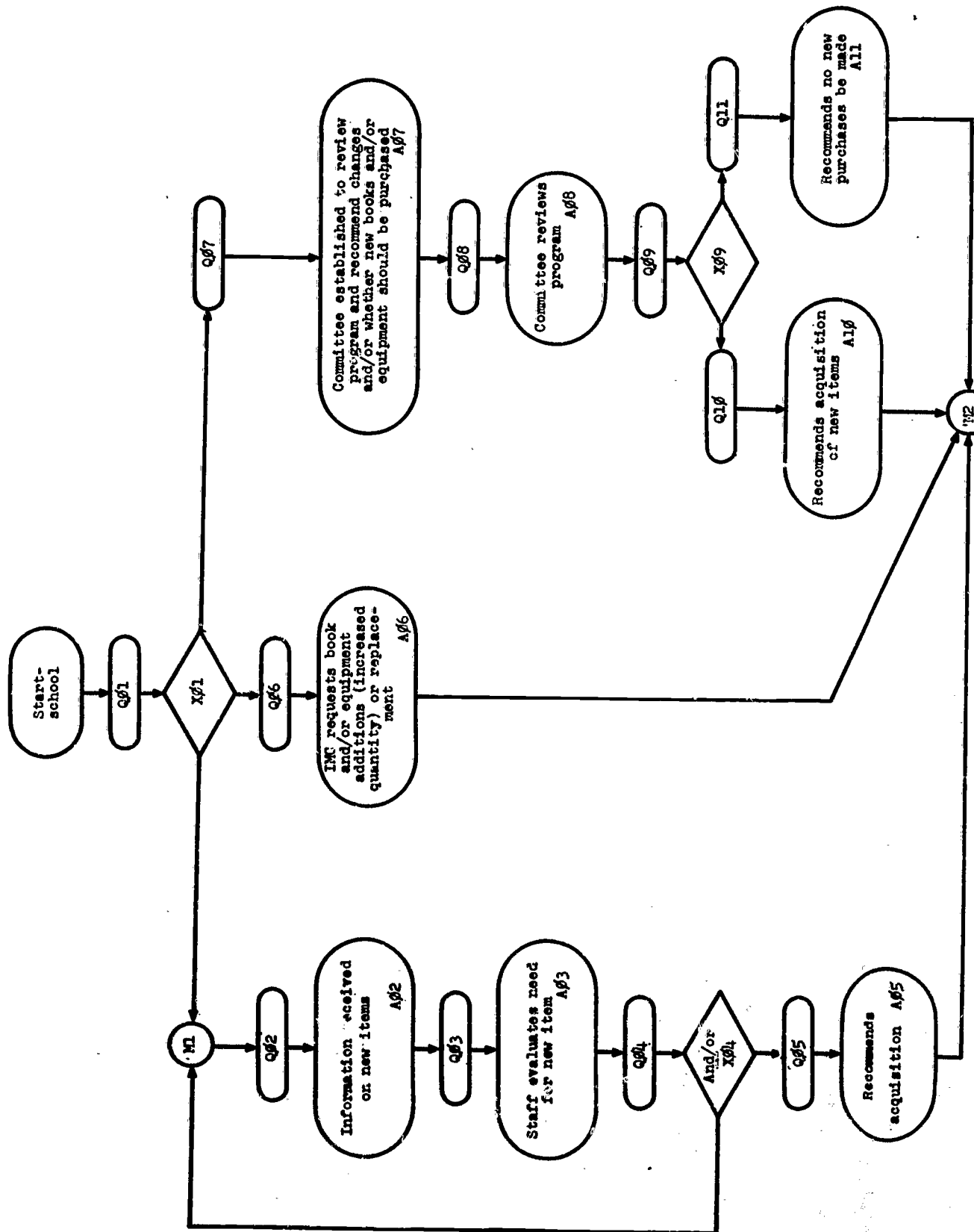
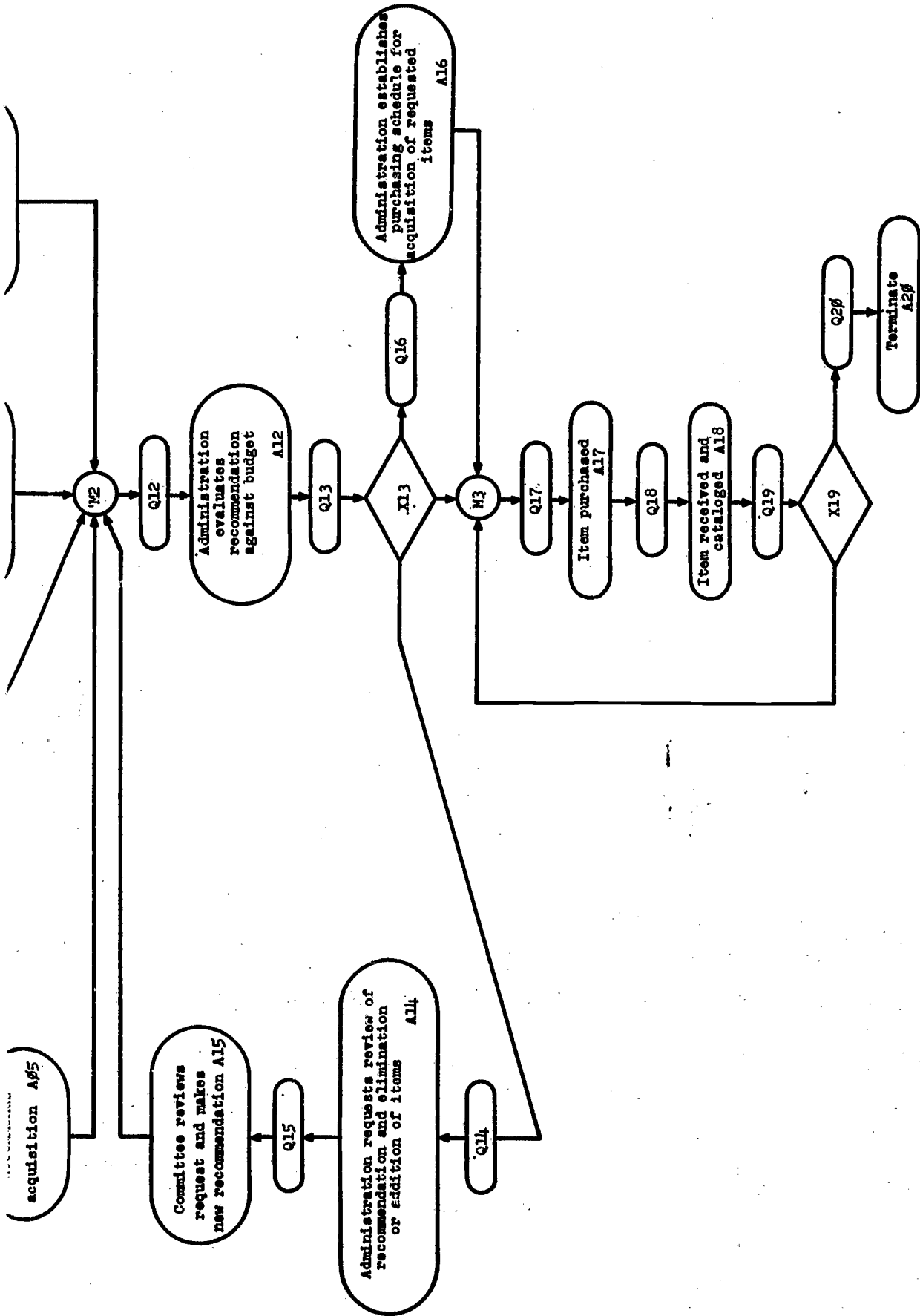

Figure 2. Acquisition of New Books and Equipment for IMC.



1 August 1964

11  
(page 12 blank)

TM-1493/105/00

While procedures described in A02 to A05 and in A06 are important to operation of the IMC, a far more important long-range procedure is that described in A07 to A11. In the course of a school's existence, the program is reviewed periodically and changes recommended. These recommendations have implications for the IMC as well as for other aspects of the school's operation. In A07, notation is made of a committee established to review the program and make recommendations. The committee reviews the program (A08) and either recommends (A10) or does not recommend (A11) acquisition of new items.

All recommendations for new purchases are brought together (M2 to Q12) for administrative evaluation. Administrative officers evaluate recommendations against the budget and make one of three decisions:

- (1) The recommendations are out of line with the budget (either above or below) and should be reviewed (Q14). In this event the committee or staff member reviews the original request and revises it to meet budgetary restrictions (A15), with the administration then reviewing the new request (A12).
- (2) The recommendations are sound but are beyond limits of the current budget. The administration then establishes a purchasing schedule for acquisition of the requested items (A16).
- (3) The budget may permit immediate purchase of items deemed necessary (Q17).

In the case of alternatives "2" and "3," items are purchased (A17) and subsequently received and catalogued (A18), at which time they are ready for use.

### Circulation of Books

Aside from teachers, books constitute the most valuable and time-honored learning resource of a school. Responsibility for circulation of books is, therefore, one of the major responsibilities of a school. In the Continuous Progress School, this responsibility resides with the IMC. Procedures for book circulation are described in Figure 3.

On student request, books are issued for a specified time period (A01). This time period may range from a day or two in the case of certain reserve books to a year or more in the case of a text for a course.

When a book is issued for an extended time period (Q03), as in the case of a text, the stock is evaluated (A03) to determine whether additional copies of the book should be ordered. If indications point to a need for more copies (Q05), such a request is submitted (A05). If indications are that the supply is adequate (M1 to Q06), no action is taken.

PRECEDING PAGE BLANK-NOT FILMED

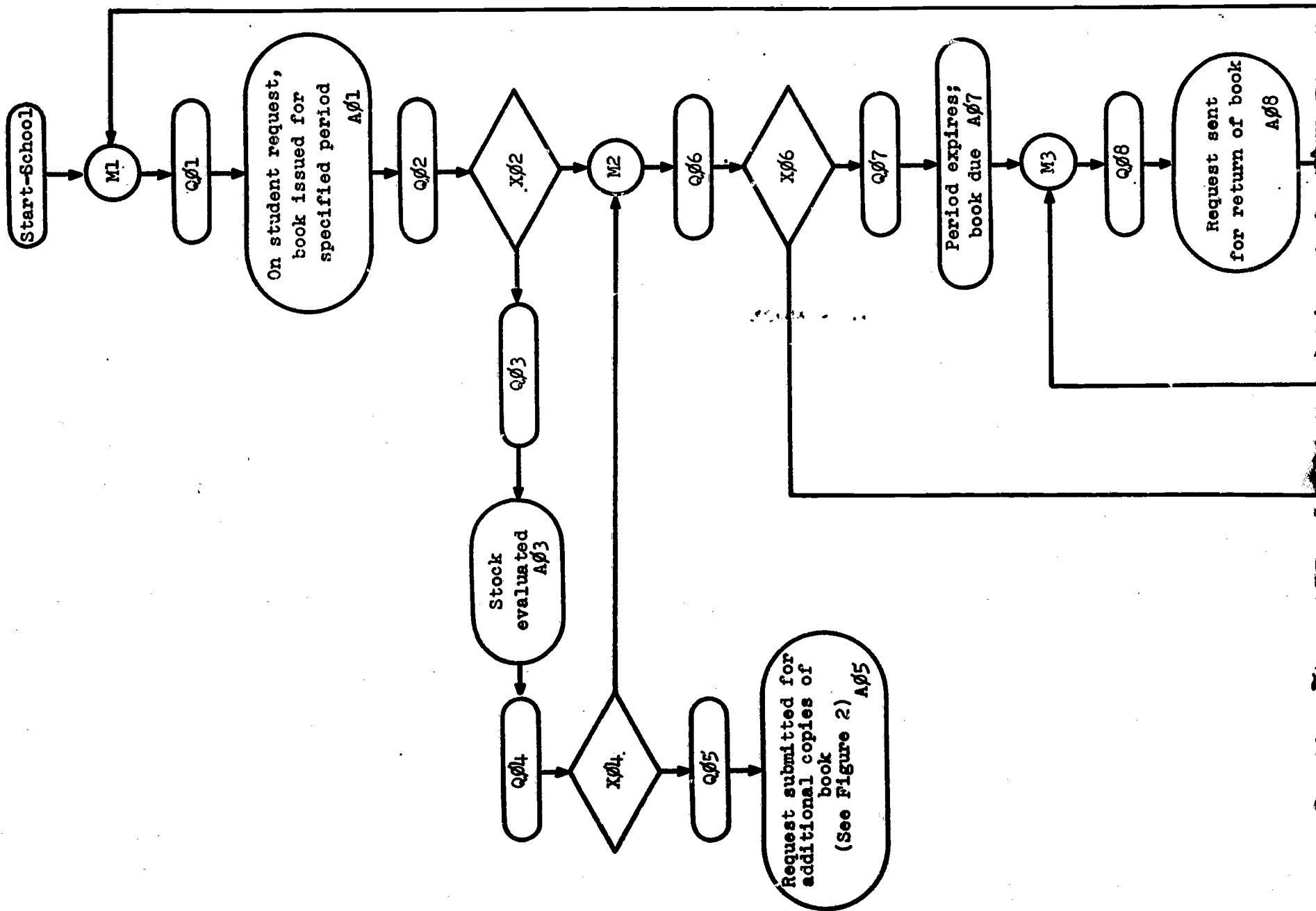
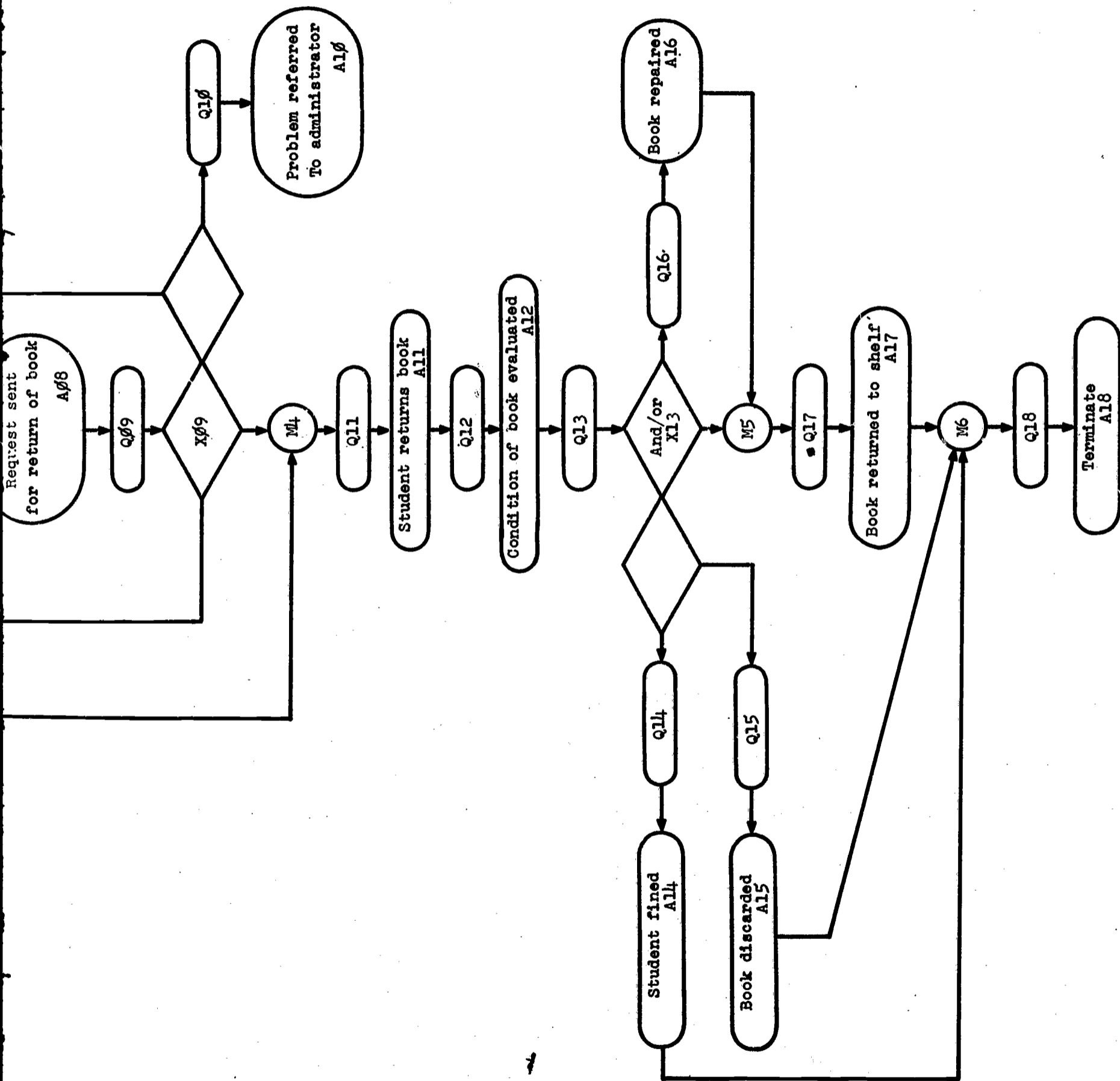

Figure 3. Circulation of Books



1 August 1964

15  
(page 16 blank)

TM-1493/105/00

Most students return their books by the due date (X06 to A11 via M4 and Q11); however, sometimes they do not (A07). In the latter event, a request is sent for the return of the book (A08). Ordinarily, the book is then returned (X09 via M4 to A11). Sometimes the student wants to keep the book longer, in which case it is reissued to him (X09 via M1 to A01). In some instances the student does not respond to the request. If only one "return request" has been sent, another is forwarded to him (X09 via M3 to A08). If the student still does not respond, the problem is referred to an administrator (A10).

When a book is returned to the IMC, its condition is evaluated (A12). Three alternatives are possible. The book ordinarily is in good condition, in which case it is simply returned to the shelf (A17); it may be damaged, in which event the book is repaired (A16) and then returned to the shelf; the book may be so badly damaged that it must be discarded (A15). In case the book is damaged, the student may be fined (A14) depending on circumstances and extent of the damage.

When the book has been discarded or returned to the shelf, a book "loan" is considered to have been completed (A18).

#### Scheduling and Use of IMC Facilities

One of the more important IMC functions is that of scheduling and supervising use of space and equipment. This function is portrayed graphically in Figure 4. In Figure 4, the IMC is shown as giving the IPC (Information Processing Center) information on equipment and space availability (2A01), and students are depicted as requesting space and equipment (1A01). When the IPC receives these inputs, it schedules students according to their priorities and according to availability of space and equipment (3A01) and reports the schedules back to the students and the IMC (3A02).

When the student receives his schedule, he reports to the IMC (1A02) and receives his space and/or equipment (2A02), which he uses (1A03 and 2A03) until completion or until the next student arrives. At this time he releases his IMC facilities (1A04 and 2A04) and terminates this activity (1A05).

When equipment is returned to the IMC (2A04) this equipment must be inspected (2A05) for defects. Normally, it is in satisfactory condition and is returned to operation (2X06 via 2M1 to 2A01). Sometimes the equipment needs servicing or repairing. This function is effected before the equipment is returned to operation (2A11). On rare occasions equipment is so badly damaged that it is discarded (2A07). Evaluation is then made of the need for replacement (2A08), and if necessary, replacement is recommended (2A10). In any event, the system loops back, via 2M1, to the beginning.

PRECEDING PAGE BLANK-NOT FILMED

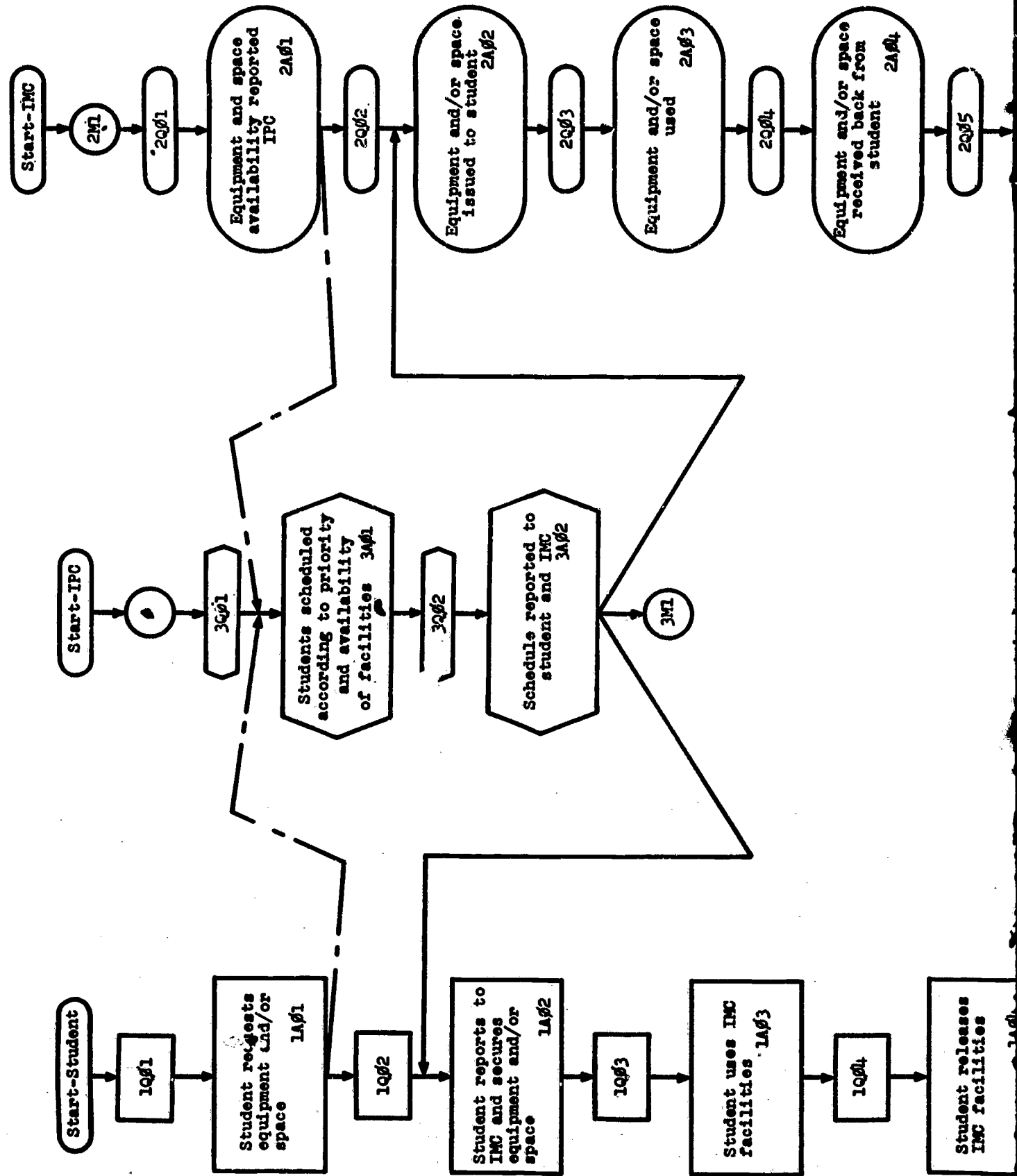
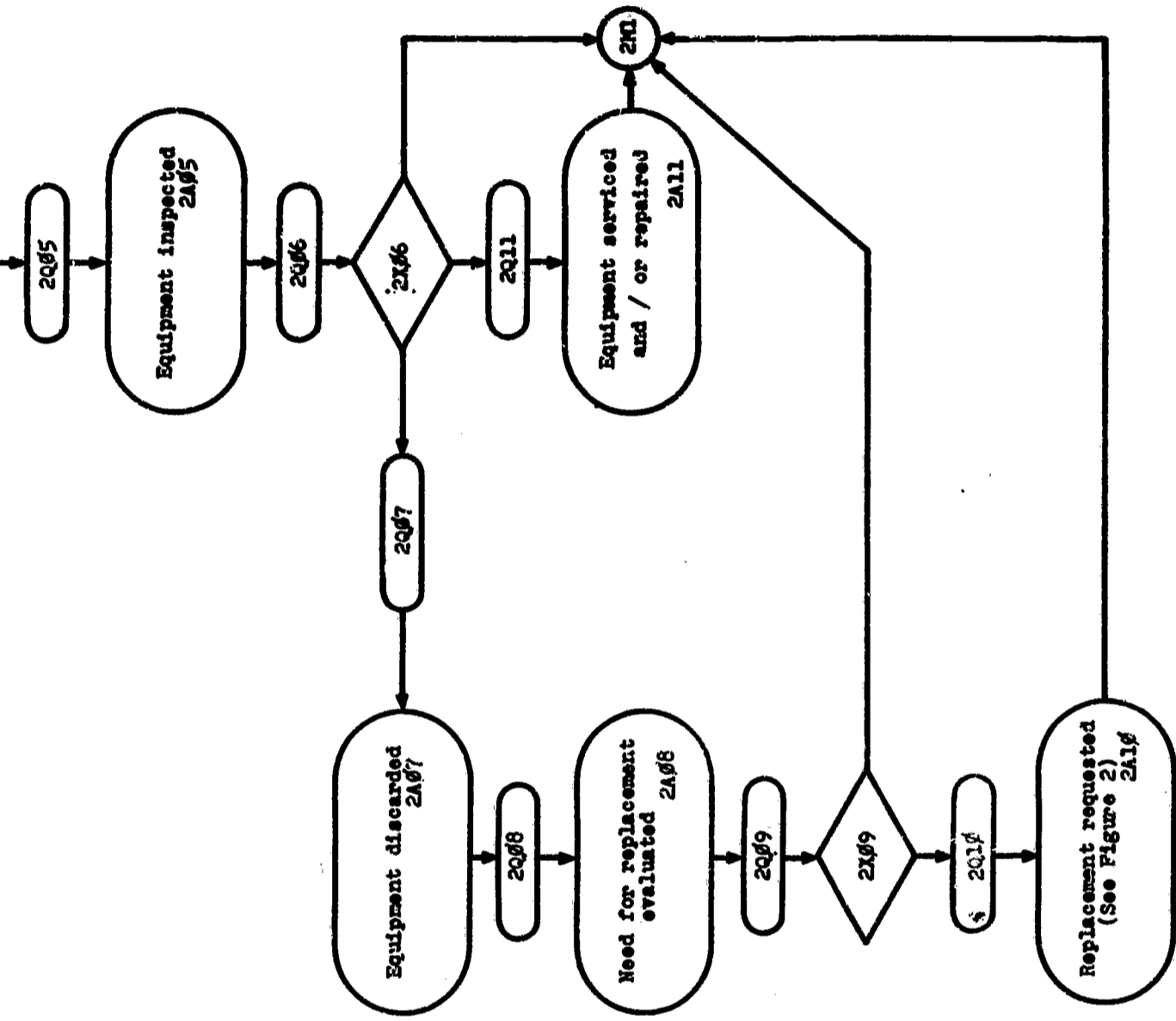
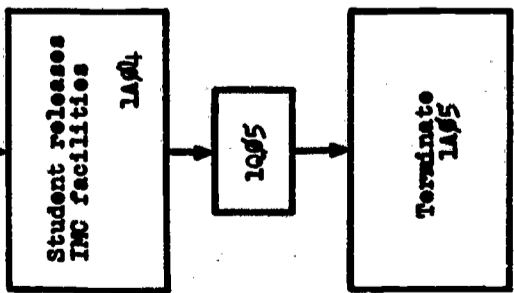

Figure 4. Scheduling and Use of IMC Facilities





1 August 1964

19  
(Last page)

TM-1493/105/00

SUMMARY

TM-1493/105/00 is the third in a series of documents describing operation of a Continuous Progress School. This document deals with the Instructional Materials Center (IMC)--a center in which are combined library, bookstore, audiovisual center, and materials development functions. Furthermore, some of these functions are substantially different in a CPS than in a traditional school. For example, all books, both library and text, are circulated via the IMC. This is because the Continuous Progress Plan permits students to progress at varying rates through the curriculum, so that while one student may begin geometry on the first day of school and finish on the last day, another student may begin on the twenty-third day of school and finish on the eighty-sixth, and still another student may begin on the twenty-third day and not finish until the seventy-fifth day of the ensuing year. Thus, all books need to be available on a variable time basis.

In the CPS, audiovisual equipment and materials are utilized on the basis of student rather than faculty request. When an individual student is ready for a particular film or tape or other audiovisual presentation, he requests it. While this procedure permits much greater flexibility, it also places much greater demands on equipment, materials, and scheduling. Arrangements must be made to meet these increased demands.

In TM-1493/105/00, four facets of the IMC are portrayed and described. These are (1) acquisition and disposition of purchasable items, which parallel similar functions in a traditional school; (2) acquisition of new books and equipment, a function which is also typical; (3) circulation of books, which differs from the traditional form because of the continuous progress nature of the school; and (4) scheduling and use of IMC facilities, which also differ because this is a Continuous Progress School.