

R E P O R T R E S U M E S

ED 010 559

56

CONSTRUCTION OF SCHOOL SIMULATION VEHICLE.

BY- COGSWELL, JOHN F. AND OTHERS

SYSTEM DEVELOPMENT CORP., SANTA MONICA, CALIF.

REPORT NUMBER NDEA-VISA-1130-02

PUB DATE 6 AUG 63

REPORT NUMBER BR-5-0738-02

REPORT NUMBER TM-1409

GRANT OEG-7-14-9120-217

EDRS PRICE MF-\$0.09 HC-\$2.00 50P.

DESCRIPTORS- *MODELS, *SIMULATION, *COMPUTER ORIENTED PROGRAMS, DATA COLLECTION, ADMINISTRATION, *SCHOOL ORGANIZATION, SCHOOL PLANNING, SCHOOL SCHEDULES, *INSTRUCTIONAL INNOVATION, *SYSTEMS ANALYSIS, SIMFAC, CONTINUOUS PROGRESS PLAN SCHOOLS, PALO ALTO, CALIFORNIA, SANTA MONICA

A COMPUTER PROGRAMED GENERAL SCHOOL SIMULATOR IS DESCRIBED AND RULES ARE GIVEN FOR A COMPUTER TRYOUT OF THE PILOT VERSION. ALTHOUGH THE MODEL WAS DESIGNED AS A GENERAL VEHICLE THAT WOULD PERMIT COMPUTER MODELING OF ANY SCHOOL CONFIGURATION, THE FIRST PILOT VERSION REPRESENTS A HYPOTHETICAL SCHOOL OPERATING UNDER THE "CONTINUOUS PROGRESS PLAN" WHICH PROVIDES FOR STUDENTS TO BE ASSIGNED TO BOTH GROUP AND INDIVIDUALIZED INSTRUCTION. PLANS CALLED FOR THE GENERAL MODEL TO BE DEVELOPED BY MODELING AND MAKING COMPUTER RUNS OF A SERIES OF VERSIONS OF THE SIMULATOR BASED ON SUCH FACTORS AS SCHOOL OPERATIONS AND ORGANIZATIONAL CONFIGURATIONS. A DATA ANALYSIS AND REDUCTION PROGRAM ALSO WILL BE DEVELOPED IN SUCCESSIVE STAGES. FLOW DIAGRAMS OF THE VARIOUS PROCEDURES OF THE SYSTEM WERE INCLUDED. RELATED REPORTS ARE ED 010 578, ED 010 579, AND ED 010 581. (AL)

ED010559



TM-1409

Construction of School Simulation Vehicle

6 August 1963

U. S. DEPARTMENT OF HEALTH, EDUCATION AND WELFARE

This document has been reproduced exactly as received from the person or organization originating it. Points of view or opinions stated do not necessarily represent official Office of Education position or policy.

TECHNICAL MEMORANDUM

(TM Series)

U. S. DEPARTMENT OF HEALTH, EDUCATION AND WELFARE
Office of Education

This document has been reproduced exactly as received from the person or organization originating it. Points of view or opinions stated do not necessarily represent official Office of Education position or policy.

The research reported herein was conducted under SDC's independent research program and a grant from the Office of Education, U. S. Department of Health, Education, and Welfare.

Construction of School Simulation Vehicle

SYSTEM

by

DEVELOPMENT

J. F. Cogswell, R. L. Egbert,
D. G. Marsh, Frank Yett, Consultant

CORPORATION

August 6, 1963

2500 COLORADO AVE.

Title VII of P.L. 85-864
National Defense Education Act of 1958
Grant 7-14-9120-217

SANTA MONICA

CALIFORNIA

The views, conclusions, or recommendations expressed in this document do not necessarily reflect the official views or policies of agencies of the United States Government.



Excepting agencies of the United States Government, permission to quote from this document or to reproduce it, wholly or in part, should be obtained in advance from the System Development Corporation.

Construction of School Simulation Vehicle

This report constitutes a description of the current status of the school simulation vehicle being constructed under partial support of USOE Grant Number 7-14-9120-217 (Egbert, 1963). As an initial step, project members have formulated a first version of a general school simulator, which is being programmed in SIMPAC (Bennett, 1962). The report contains a general description of this vehicle and the rules generated for a computer try-out of the first, pilot version.

The first version of the school simulation model is being programmed for computer try-out for the following reasons:

- (1) To provide familiarity with the SIMPAC programming procedure;
- (2) To provide information to help in the formulation of a data analysis or reduction program;
- (3) To provide data that may be used to evaluate the subjective reasonableness of the logic contained in the model.

Although the model is being designed as a general vehicle that will permit computer modeling of any school configuration, the rules and configuration for the first pilot version will represent a hypothetical school operating under the Continuous Progress Plan (Egbert and Cogswell, 1963; Read and Crnkovic, 1963), where students are assigned to both group and individualized instruction. It is planned that the general model will be constructed by successive iterations of versions in which various school operations, organizational configurations, etc., are modeled and run on the computer. The data analysis and reduction program will also be built in successive stages.

General Description of the School

Simulation Vehicle--Version One

The initial, general model is called "Instruct" and consists of a hierarchical order with five levels of generality.

The five levels of generality, from most inclusive to least inclusive, are as follows: system, module, package, procedure, and activity. Additional versions will include more detailed levels which will be referred to as routines and sub-routines.

The present configuration consists of the following:

System Level

Instruct System (Figure 1, Appendix)

The instruct system is the total configuration of the initial simulation vehicle. The next level is the module.

Module Level

Control Module

Outside Resources Module

Subject Alpha Module

Subject Beta Module

Subject Gamma Module

Subject Delta Module

Subject Epsilon Module

The Control Module serves the general function of getting students in and out of the school and determining their general flow in the school.

The Outside Resources Module consists of all of those agencies outside of the school that may deal with the students and with which the school must concern itself. Courts, child guidance clinics, recreation programs, other schools, etc., represent outside resources.

The subjects Alpha through Epsilon represent five different subject matter courses. Each course consists of four units characterized by four study packages and three projects, each represented by a study package. Also in each course or subject matter module is an evaluation package.

Package Level

The Control Module consists of the following packages:

Begin package (2.1*), Figure 2, Appendix
Counsel package (10.21), Figure 3, Appendix
Terminate package (3.1), Figure 12, Appendix
Diagnostic-Prognostic package (13), Figure 4, Appendix

The Outside Resources Module consists of the following package:

Outside resources package (14), Figure 5, Appendix

The Subject Modules each consist of the following packages.

Study Package Unit One (4.2), Figure 7, Appendix
Study Package Unit Two (4.2)
Study Package Unit Three (4.2)
Study Package Unit Four (4.2)
Study Package Project One (4.2)
Study Package Project Two (4.2)
Study Package Project Three (4.2)
Evaluate Package (9.3), Figure 6, Appendix

Procedure Level

The Begin package consists of the following procedures:

Pre-admission procedure (AB1**).

Admission procedure (AB3)

Registration procedure (AB5)

The Terminate package consists of the following procedures:

*The numbers in parentheses refer to the numbers of the charts in the Appendix.

**The characters in parentheses refer to the codes associated with each of the procedures or activities. The codes are explained on page 6.

Collect, classify and schedule procedure (AT1)

Terminate applicant procedure (AT3)

Dismiss procedure (AT4)

Withdraw procedure (AT5)

Graduate procedure (AT6)

Publish and suspend file (AT7)

The Counsel package consists of the following procedures:

Collect records, classify and schedule
appointment procedures (AC1)

Counseling appraisal (AC3)

Staff appraisal (AC4)

The Outside Resources package consists of the following procedures:

Assign procedure (A01)

Use procedure (A03)

Assess procedure (A05)

The Diagnostic-Prognostic package consists of the following procedures:

Review recommendations and select
outside resource procedure (AD1)

Schedule outside resource and modify
student progress procedure (AD3)

The Evaluate package consists of the following procedures:

Schedule, collect and classify procedures (AE1)

Review counsel package recommendations (AE3)

Review subject performance and make
recommendations (AE5)

Review concurrent activity in this
subject and make recommendations (AE7)

Each Study package consists of the following procedures:

- Assign procedure (AS1)
- Do procedure (AS2)
- Help procedure (AS4)
- Assess procedure (AS5)

Activity Level

The Assign procedure (Figure 8, Appendix), consists of the following activities:

- Assign mode of work and work content (AS11)
- Assign individual study work space (AS13)
- Assign group study work space (AS15)

The Do procedure (Figure 9, Appendix), consists of the following activities:

- Work (AS21)
- Determine to help, assess, or assign (AS23)

The Help procedure (Figure 10, Appendix), consists of the following activities:

- Schedule mode of help (AS41)
- Give extended session help (AS43)
- Give short session help (AS45)

The Assess procedure (Figure 11, Appendix), consists of the following activities:

- Determine mode of assessment (AS51)
- Formal assessment (AS53)
- Informal assessment (AS55)

Programming and Coding Conventions

Each task block, split, and queue is identified by a unique, three-to-five character designation. (The number of identifying characters depends on whether an Instruct procedure or activity or routine is being described.)

In the unique designation of a task block, split, or queue, the first symbol, starting from the left, is an

X for a split, an

A for a task block, or a

Q for a queue.

The second symbol designates the package as follows:

(B) Begin package

(E) Evaluate package

(S) Study package

(C) Counsel package

(O) Outside Resources package

(D) Diagnostic-Prognostic package

(T) Terminate package

The third character is a digit, letter or symbol which refers to the specific procedure within the package. The fourth character is a digit, letter, or symbol which refers to the particular activity within a procedure. If the model was formulated at the routine level, a fifth character would be used to designate a particular routine within an activity.

The general procedure used in making the codes is to number the queues first in consecutive order. The activities and splits following each queue are then numbered with the same character as the preceding queue. The following examples illustrate the coding system:

AS1--is the procedure (Assign) following the first Queue (Q1) in the study package. The A refers to activity and the S refers to the Study package.

AS13--is the activity following the third Queue (QS13) in the Assign procedure. The A refers to activity. The S stands for Study package, and the 1 stands for the Assign procedure of the Study package.

Version One--Configuration Rules

The school decision characteristics and the student characteristics of the first pilot version of the school simulation vehicle are not based on any real school, but rather have been formulated to maximize testing of the model. However, an attempt has been made to maintain an air of subjective realism by basing the decisions on the Continuous Progress Plan school.

The following rules have been formulated to test this first version. (If the reader is to understand the implication of the rules, he must refer to the appropriate flow diagrams in the appendix.)

The splits referred to in the following section are coded on the flow diagrams in the appendix. The rules associated with the split options are described in the enclosed boxes on each of the flow diagrams entitled "Recommendations."

Basic Data for Cycling the School Simulation Vehicle

Time

The basic time Unit is expressed in 1/8's of an hour. This time unit is equivalent to 7.5 minutes.

Classification of Student Rates

For all five subject modules (alpha-epsilon) 20 percent of the students perform at a fast (F) rate, 60 percent of the students perform at a medium (M) rate, and 20 percent perform at a slow (S) rate. The rates (F, M, S) will be assigned randomly to students on the first unit (study package one) of subject Alpha. They will all cycle through the Do (AS2) procedure twenty-five times. Because of the decision rules regarding Help and Assess, students will vary in the length of time it takes to complete the unit even though each one goes through the Do procedure twenty-five times.

In order to base the classification of rates on empirical data the students will be reclassified at the end of unit one on the basis of their order of exit from unit one. The first 20 percent of the students, or the first 200 of 1,000 students entered, to complete Unit #1 will be designated Fast and will be assigned a Do rate of 20 for Unit #2. In other words, the Fast students will only cycle through Do twenty times in Unit #2. The next 60 percent or 600 students to exit in order from Unit #1 will be designated

Medium and will be assigned a Do rate of 25. The last 20 percent or 200 students will be designated as Slow and will be assigned a Do rate of 30.

At the end of Unit #2 in each of the five subject modules (alpha through epsilon) the run will be stopped. The 1,000 students will be assigned to the first queue of the next subject and the cycling will be restarted through the first unit of the new subject module. The subjects will maintain the rates assigned to them in Unit #1, but new rates will be assigned at the completion of Unit #1 before continuing with Unit #2.

In the Group mode of instruction (XS12-1) all rates for all students will be set to M (medium). In the Individual mode of instruction (XS12-0) the F (fast), M (medium), S (slow) rates appropriate to each student are used.

Subject Characteristics

Study Units 1-4 are considered sequential units of the courses whereas Study packages (projects) 1-3 are considered projects in the courses.

Subject Alpha

Some of the work is distributed to group activity and some to individual assignment. This distribution is handled by the following rules:

In study packages 1-4 at XS12 60% of the assignments take branch - 0 (Individual), and 40% of the assignments take branch - 1 (Group).

The assignments to projects in course alpha should be as follows:

Project one:	XS12-0	0%
	XS12-1	100%
Project two:	XS12-0	100%
	XS12-1	0%
Project three:	XS12-0	50%
	XS12-1	50%

Subject Beta

In Subject Beta all of the unit work is group work; therefore, the assignments for Units 1-4 are as follows:

6 August 1963

-9-

TM-1409

XS12-0 0%

XS12-1 100%

The projects are assigned in the same proportions as Subject Alpha.

Subject Gamma

In Subject Gamma all of the unit work is individual; therefore, the assignments for Study Package Units 1-4 are as follows:

XS12-0 100%

XS12-1 0%

The projects are assigned in the same proportions as Subject Alpha.

Subject Delta

In Subject Delta the assignments to group and individual work in the unit work depend upon the rate characteristics of the particular student. The following rules are applied for Study Package Units 1-4:

For Fast Students

XS12-0 100%

XS12-1 0%

For Medium Students

XS12-0 50%

XS12-1 50%

For Slow Students

XS12-0 0%

XS12-1 100%

The projects are assigned in the same proportions as Subject Alpha.

Subject Epsilon

Assignments in Subject Epsilon are also depended upon student rate. The following rules are applied for Study Project Units 1-4:

For Fast Students

XS12-0 0%

XS12-1 100%

For Medium Students

XS12-0 50%

XS12-1 50%

For Slow Students

XS12-0 100%

XS12-1 0%

The projects are assigned in the same proportions as in Subject Alpha.

Enter PackageQB1

At the beginning of the computer run 1000 students are in queue QB1 waiting to be processed. Five hundred of the students are designated as males and five hundred as females. The sex designation of each student is assigned randomly to students 1--1000 by table look-up.

The students are transferred to AB1, the pre-admission procedure, in sequential order.

XB2

0 0%

1 100%

All students are accepted into pilot version one; therefore, 100% of the students take branch #1 from XB2, indicating that admission has been recommended and that they are to proceed to the Admission Procedure (AB3) through QB3.

XB4

0 0%

6 August 1963

-11-

TM-1409

1 100%

Since all students are accepted, 100% of the students proceed through branch #1 of XB4 to the Registration Procedure (AB5).

XB6

0 0%

2 100%

2 0%

In pilot version one all students must see a counselor before being assigned to their course work; therefore, 100% of the students take branch #1 at XB6.

Counsel Package (From Enter Package)

Students may enter the Counsel package from the Evaluate package, The Outside Resources package or the Enter package. The rules associated with students coming from a particular package will be presented in logical sequence; therefore, only the rules for students coming from the Enter package will be discussed at this point. The rules pertaining to the processing of students from the other two packages will be discussed following the presentation of the rules for these packages.

XC2 (If from XB6-1)

0 100%

1 0%

Students coming from the Enter package are designated as students who have come through XB6-1. All students coming from the Enter package take branch #0, i.e., they are assigned to a Counseling Appraisal (AC3) with the counselor. No entering students in Pilot Version One are sent for Staff Appraisal (AC4).

AC3

The student's schedule is programmed in the Counseling Appraisal procedure.

The time for the scheduling interview will fit a Poisson distribution with a mean of about 30 minutes, a minimum time of 22.5 minutes and a maximum time of 60 minutes.

XC5 (If from XB6-1)

0 0%

1 0%

2 100%

All students who have come to the Counsel package from the Enter package (XB6-1) will proceed to the Evaluate package of the first scheduled course Subject Module Alpha.

Evaluate PackageXE2

If students come from Study, take branch--0

If students come from Counsel, take branch--1

Branch--0 of XE2 sends the students to Review Subject Performance and Make Recommendations (AE5). If students come from Study it is assumed that students have come from either the Assess procedures or the Help procedure and that evaluation and decisions must be made in regard to the next step.

Branch--1 of XE2 sends students to Review Counsel Package Recommendations (AE3). It is assumed that, if students come from counsel, the policy of the school is to review any recommendations coming from the counseling function before proceeding with the evaluation.

All new students or all students referred to the Counsel package from Study would be sent to AE3 in the Evaluation package.

XE6

0% of fast students	}	branch--0
5% of medium students		
10% of slow students		
100% of fast students	}	branch--2
95% of medium students		
90% of slow students		

If students from Help (XS44) take branch--4 at XE6

Students who take branch--0 from XE6 are experiencing difficulty in their performance and have been referred by a teacher to the Counsel package for additional consultation. In other words, the teacher has decided that he can not deal with the problems. These students in trouble represent only a small portion of the student body. As indicated in the distribution, none of the fast students fall in this category. The majority of those students who are referred to counseling are slow students.

Students who take branch--2 from XE6 are students who are performing adequately in the course and are ready for the next unit or project or are ready to begin the course. They are sent to Review Concurrent Activity in this Subject and Make Recommendations (AE7) for consideration of any additional work that they may be doing or want to do.

Students who come from Help (XS44-0) are students who have been given an Extended Session Help (AS43) and whose performance in the subject needs to be reviewed. Branch--4 from XE6 indicates that the review has resulted in the decision that they should continue with the current study package. They will proceed to XE8 where they will take branch--3.

Study Package

Figure 7 in the Appendix shows the flow of students through the Study package. Since the procedures--Assign, Help, and Assess--have been formulated at the activity level, all of the rules are defined at the latter level. The subject matter variations on pages 8-10 describe the Assign rules for each subject module (alpha-epsilon). The following rules for Do, Help and Assess apply to all of the study and project units within all of the courses, except when an exception has been noted.

Do Procedure

In the Do procedure students Work (AS21) in the mode they were assigned (AS13) or (AS15) in the Assign procedure. From Work they may branch to one of three options. XS22-0 implies that the student checks to see if he is ready for assessment, or should go on working (back to assign). XS22-1 implies that the student has decided that he needs help. XS22-2 implies that the student has decided that he needs some kind of assessment.

The specific rules for Do are designed with the intention of forcing the slower students to get more help than the faster

students. The following distributions for Do have been formulated for Pilot Version One:

For Fast Students

XS22-0 80%

XS22-1 5%

XS22-2 15%

For Medium Students

XS22-0 70%

XS22-1 15%

XS22-2 15%

For Slow Students

XS22-0 70%

XS22-1 15%

XS22-2 15%

For Fast Students

XS24-0 0%

XS24-1 5%

XS24-2 95%

For Medium Students

XS24-0 10%

XS24-1 10%

XS24-2 80%

For Slow Students

XS24-0 25%

XS24-1 25%

XS24-2 50%

AS21

Each time that the student comes to the Work task (AS21), he will stay for one time unit or 7.5 minutes.

Subject Matter Exceptions for Do

In Subject Beta the following rules will apply at XS22

For all Students

XS22-0	80%
XS22-1	5%
XS22-2	15%

Help Procedure

The Help procedure rules are formulated to provide the slower students with more of the Extended Session Help (AS43). The following rules for Help have been formulated:

For Slow Students

XS42-0	30%
XS42-1	70%

XS44-0	10%
XS44-1	90%

XS46-0	10%
XS46-1	90%

For Medium Students

XS42-0	50%
XS42-1	50%

XS44-0	5%
--------	----

XS44-1	95%
--------	-----

XS46-0	10%
--------	-----

XS46-1	90%
--------	-----

For Fast Students

XS42-0	70%
--------	-----

XS42-1	30%
--------	-----

XS44-0	0%
--------	----

XS44-1	100%
--------	------

XS46-0	10%
--------	-----

XS46-1	90%
--------	-----

AS43

The time for the Extended Session Help is set at a Mean of 2 units or 15 minutes with a S.D. of $\frac{1}{2}$ or 3.75 minutes.

AS45

The time for Short Session Help is $\frac{1}{4}$ unit or about 1.9 minutes with a S.D. of $\frac{1}{8}$ or about .9 minutes.

Assess Procedure

Two kinds of assessment have been defined in the model--Formal Assessment (AS53) and Informal Assessment (AS55). Formal assessment is the end of unit test, such as the final exam, the mid-semester test, etc., that is a characteristic part of the assessment procedure of the course. Informal procedure includes all of the more informal kinds of assessment like self-help tests

at an end of a chapter, the number of errors in a programmed lesson, a teacher's interview, quizzes, etc.

In Pilot Version One 50% of the time that students are assessed, the assessment is formal and 50% of the time the assessment is informal. Therefore, the following rule applies for all students at XS52:

XS52-0	50%
XS52-1	50%

The rules of distribution again favor the faster student. The following rules are set for each of the three groups of students.

For Fast Students

XS56-0	0%
XS56-1	0%
XS56-2	100%

*XS54-0	0%
*XS54-1	0%
*XS54-2	100%

For Medium Students

XS56-0	10%
XS56-1	10%
XS56-2	80%

*XS54-0	10%
*XS54-1	0%
*XS54-2	90%

*On last Do of a unit everyone must use XS52-1 and XS54-1 in order to go back to Evaluate.

For Slow Students

XS56-0 20%

XS56-1 20%

XS56-2 60%

*XS54-0 20%

*XS54-1 0%

*XS54-2 80%

Counsel Package (from Evaluate)

The rules set for the students coming from Evaluate must characterize attempts to help the students with problems that have been reflected by their performance in study, and appointments with a counselor for further programming when a course has been completed.

The following rules have been formulated for students coming from Academic Evaluation package. No representation of Non-Academic Evaluation has been made in Pilot Version One.

XC2

Subjects coming from:

XE6-0

take XC2-0

XE8-6

This rule means that the students who have been referred for the first time from Evaluate, either because they are in trouble or have completed the course, are scheduled for a session with the counselor rather than a staff appraisal.

If students from XE6 go to XC5-1, they should take XC2-branch 1. This rule sends students who have been recommended by the counselor for Staff Appraisal to the Staff Appraisal (AC4).

If students from XE6 go to XC5-0, they should take XC2-branch 0.

*On last Do of a unit everyone must use XS52-1 and XS54-1 in order to go back to Evaluate.

This rule sends students recommended for further work with a counselor to a counselor rather than to a Staff Conference.

XC5

Students from XE6-0 who have come to XC5 for the first time should be distributed as follows:

XC5-0	35%
XC5-1	60%
XC5-2	5%

This rule processes the students from XE6-0, or those students who have been referred because of some kind of adjustment problem. Because this is an adjustment group that represents a rather small portion of the total student body the majority of these students are sent for a staff appraisal.

Students from XE6-0 who have gone through XC2 a second time, will be distributed as follows at XC5:

XC5-0	0%
XC5-1	50%
XC5-2*	50%

If students from XE6-0 have been through XC6-0 they will distribute themselves as follows at XC5:

XC5-0	0%
XC5-1	0%
XC5-2*	100%

That is, all of those students who are referred back to a counselor after staff appraisal are sent back to Study via Evaluate.

Students from XE8-6 who come to XC5 for the first time will be distributed as follows:

*Return to the same Evaluate, i.e., don't go to a new one.

XC5-0	0%
XC5-1	0%
XC5-2*	100%

This rule means that the students who have seen the counselor because they have completed a subject and need further programming, go back to study after the counseling session. They go to a new Evaluate.

The times for the counseling sessions are as follows:

If from XE6-0 or XC2-0 (either 1st or 2nd time)
AC3 = 6 1/8 units or 45 minutes.

If XE8-6, AC3 = 2 1/8's or 15 minutes.

If XC6-0, AC3 = 3 1/8's or 22.5 minutes.

AC4 always = 8 1/8's or 60 minutes.

Diagnostic-Prognostic Package and Outside Resources Package

The Diagnostic-Prognostic package functions as a control package because it coordinates the flow between the school and the outside resources. The Outside Resources package represents an outside agency that works with the student in some respect that concerns the school.

In Pilot Version One, the rules are fairly simple. The following rules have been formulated for the Diagnostic-Prognostic package.

XD2

XD2-0	30%
XD2-1	70%

This rule would indicate that in 30% of the cases no appropriate agency was available and that 30% of the students are referred back to the Counsel package.

The other 70% of the referred students are sent to AD3 for scheduling of outside resources.

*New Evaluate.

If students go to XD⁴-1, the distribution will be as follows at XD²:

XD ² -0	100%
XD ² -1	0%

This indicates that the students have been returned to the Counsel package because scheduling of outside resources was impossible.

XD⁴

Of those students sent to AD³ for scheduling of outside resources, 70% are scheduled for outside resources, and 30% cannot be scheduled. The rule is as follows:

XD ⁴ -0	70%
XD ⁴ -1	30%

The following rules have been formulated for the Outside Resources Package.

XO⁴

XO ⁴ -0	0%
XO ⁴ -1	100%

This rule means that 100% of the students continue on to A05 after use (A03) of outside resources.

XO⁶

XO ⁶ -0	0%
XO ⁶ -1	100%

This rule means that all of the students go back to the Diagnostic-Frognostic package after one session in the outside agency.

The time for A03 or "use" of the outside resource is 10 sessions of 8 1/8's or 10 sixty minute sessions.

Counsel Package (Return from Outside Resources)

The following rules apply to students returning from the Outside Resources

6 August 1963

-22-

TM-1409

and Diagnostic-Prognostic packages:

XC2

If return from XD2-0 student takes XC2-0.

This means that the student is referred back to the counselor (AC3). The time for AC3 is 2 (1/8) or 15 minutes.

XC5

If from XD2-0 students take XC5-2.

This means that the students go back to study.

Terminate Package

XT2

If students come from XB2-0 of the Enter package, they take XT2-0 which means that their application is terminated. If from XC6-2 or from the "Staff appraisal" of Counsel package with the recommendation of Terminate, student takes XT2-1 which = Dismiss (AT4).

Bibliography

Bennet, R. P., et al., SIMPAC User's Manual, TM-602 (System Development Corporation Technical Memorandum), April 15, 1962.

Egbert, R. L. New Solutions to Implementing Instructional Media Through Analysis and Simulation of School Organization, System Development Corporation proposal #351, January 30, 1963.

Egbert, R. L. and Cogswell, J. F., System Design in the Bassett High School, TM-1147 (System Development Corporation Technical Memorandum), April 1, 1963.

Read, E. A. and Crnkovic, J. K. The Continuous Progress Plan. Provo, Utah: Brigham Young University Press, 1963.

6 August 1963

-24-

TM-1409

APPENDIX

(The numbers enclosed in parentheses on each Figure such as 01.4 on Figure 1 are used to number the charts and to code the version of the charts and to indicate whether it is SIMPAC-ready.)

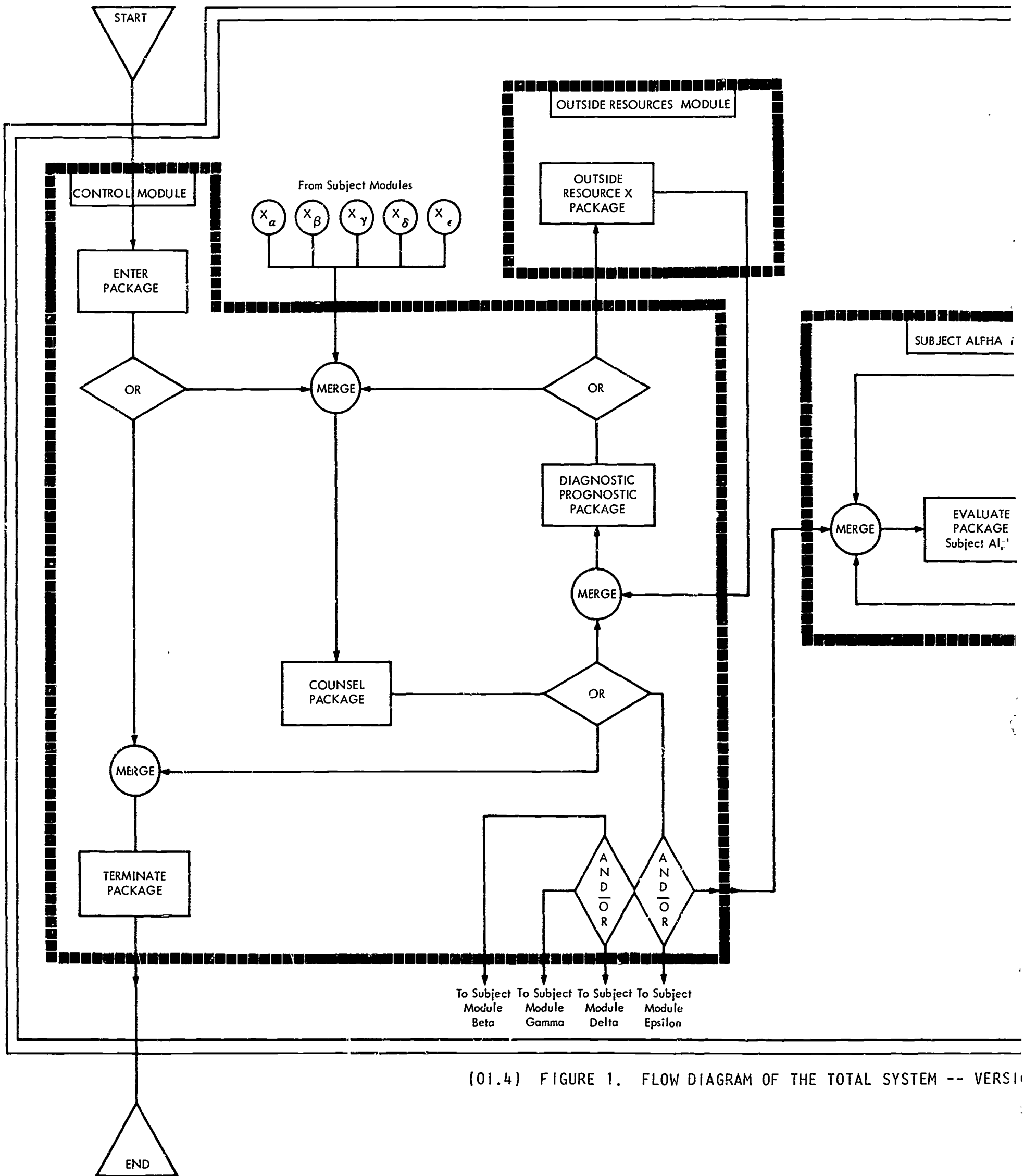

(01.4) FIGURE 1. FLOW DIAGRAM OF THE TOTAL SYSTEM -- VERSI

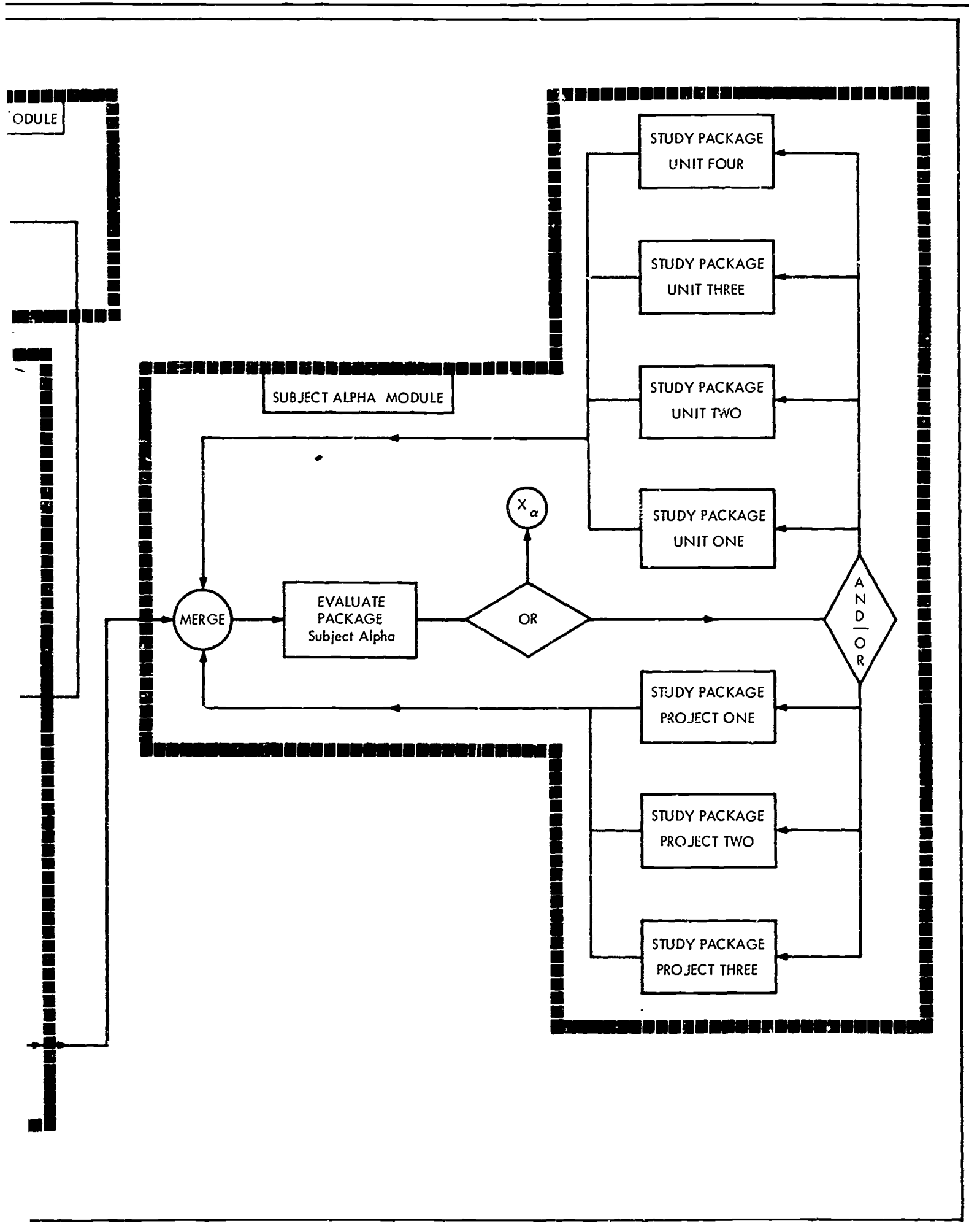

AGRAM OF THE TOTAL SYSTEM -- VERSION 1

6 August 1963

-27-

TM-1409

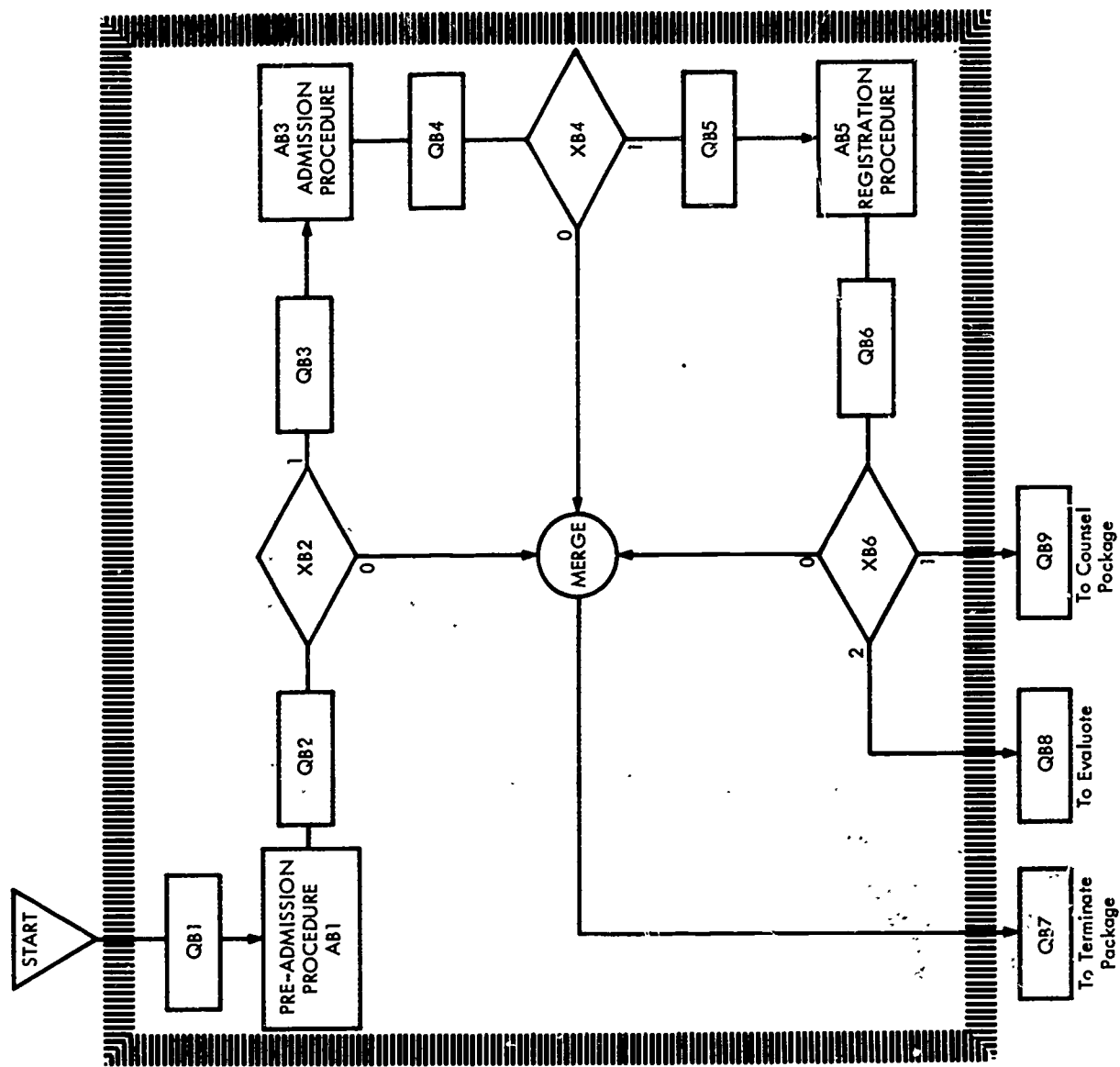

Split	Recommendation
XB2	
0:	Admission not recommended; or admission not requested by applicant; go to Terminate Package.
1:	Admission recommended; go to Admission Procedure.
XB4	
0:	Admission refused to applicant; or, applicant rejects offer of admission; go to Terminate Package.
1:	Recommend admission; go to Registration Procedure.
XB6	
0:	Recommend termination due to non-registration; go to Terminate Package.
1:	Registration complete; go to Counsel Package.

(2.1) FIGURE 2. FLOW DIAGRAM OF THE ENTRANCE PROCEDURES

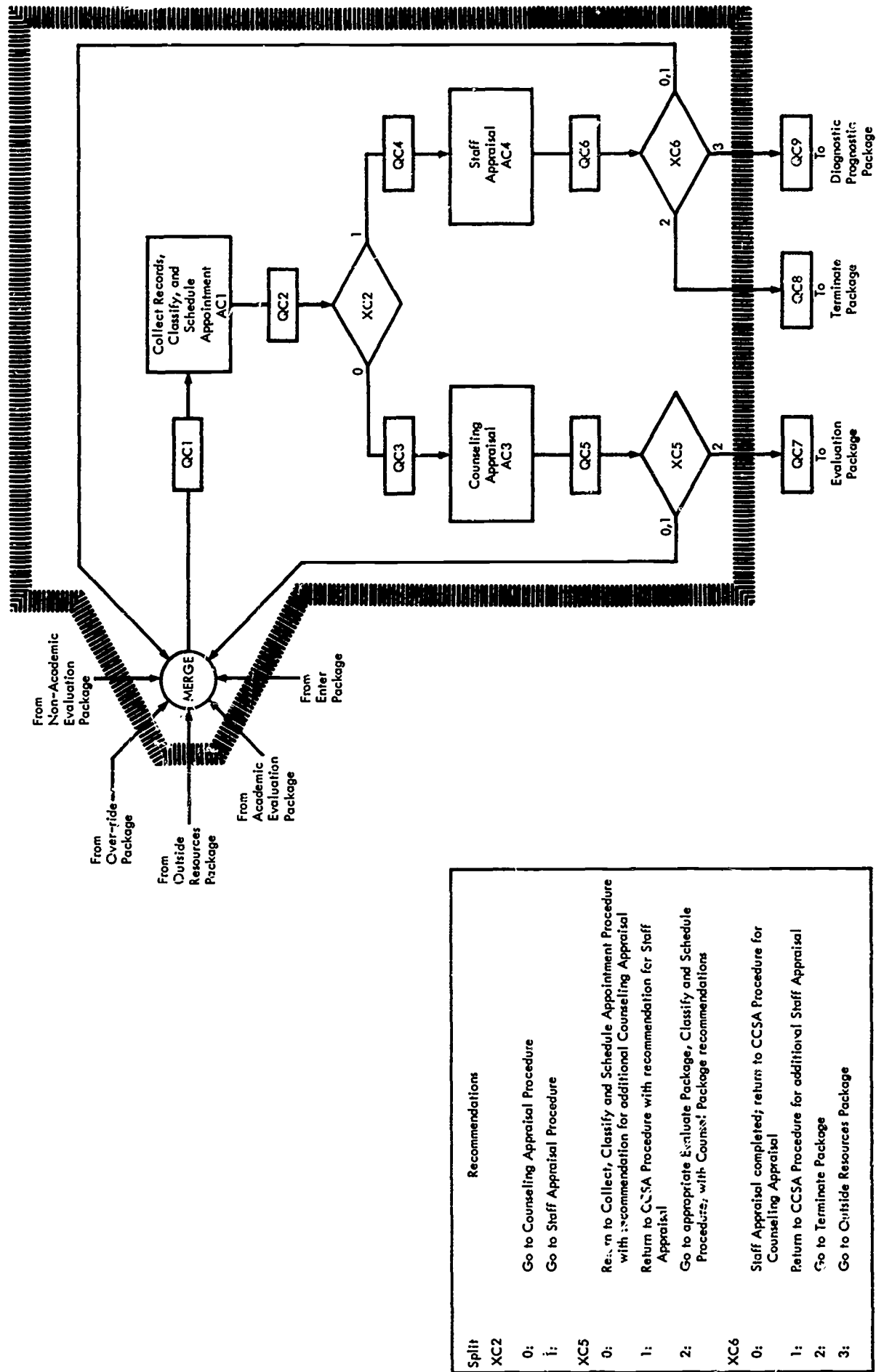

(10.12) FIGURE 3. FLOW DIAGRAM OF THE COUNSELING PROCEDURES

Recommendation	
Split	
XD2	
0:	Outside Resource Not Available or Not Further Needed; Return to COUNSEL PACKAGE
1:	Use of Outside Resource Appropriate; Go to SCHEDULE RESOURCE AND MODIFY STUDENT PROGRAM PROCEDURE
XD4	
0:	Scheduling Completed; Go to OUTSIDE RESOURCE PACKAGE "X"
1:	Scheduling not possible; Return to REVIEW RECOMMENDATIONS AND SELECT OUTSIDE RESOURCE PROCEDURE

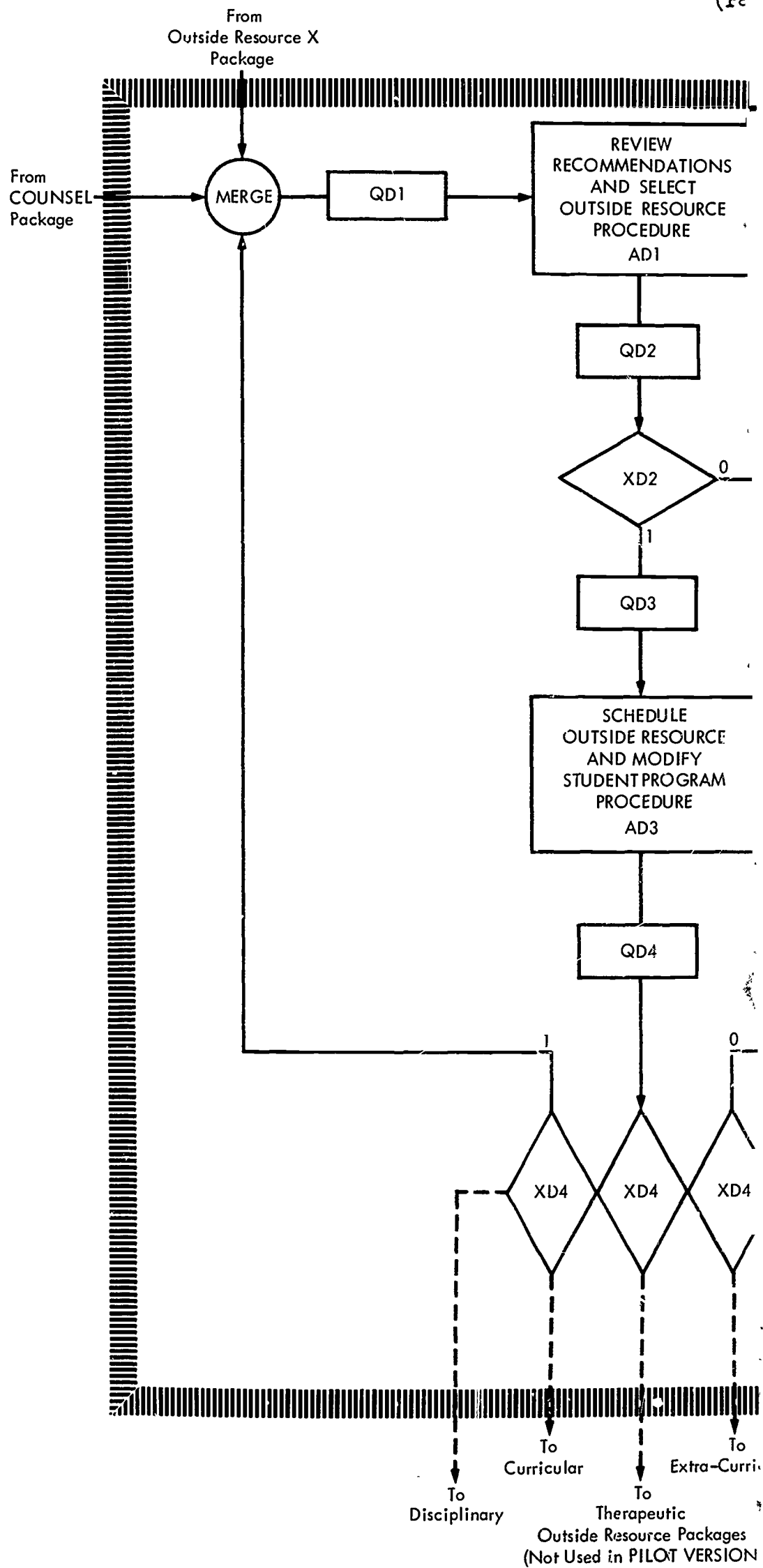

(13) FIGURE 4. FLOW DIAGRAM OF THE DIAGNOSTIC AND PROGNOSTIC PROCEDURE

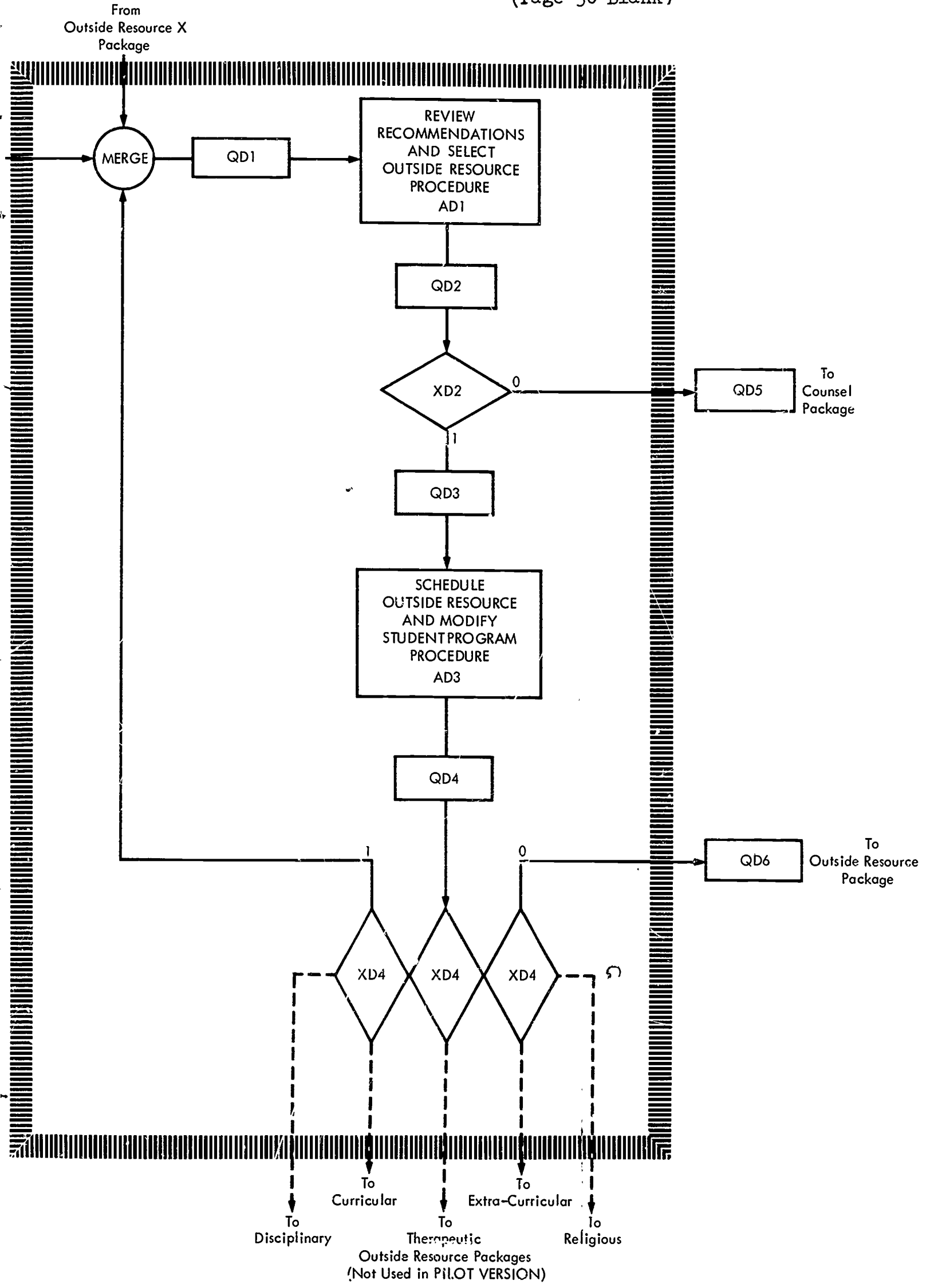

4. FLOW DIAGRAM OF THE DIAGNOSTIC AND PROGNOSTIC PROCEDURES

6 August 1963

-31-
(Page 32 Blank)

TM-1409

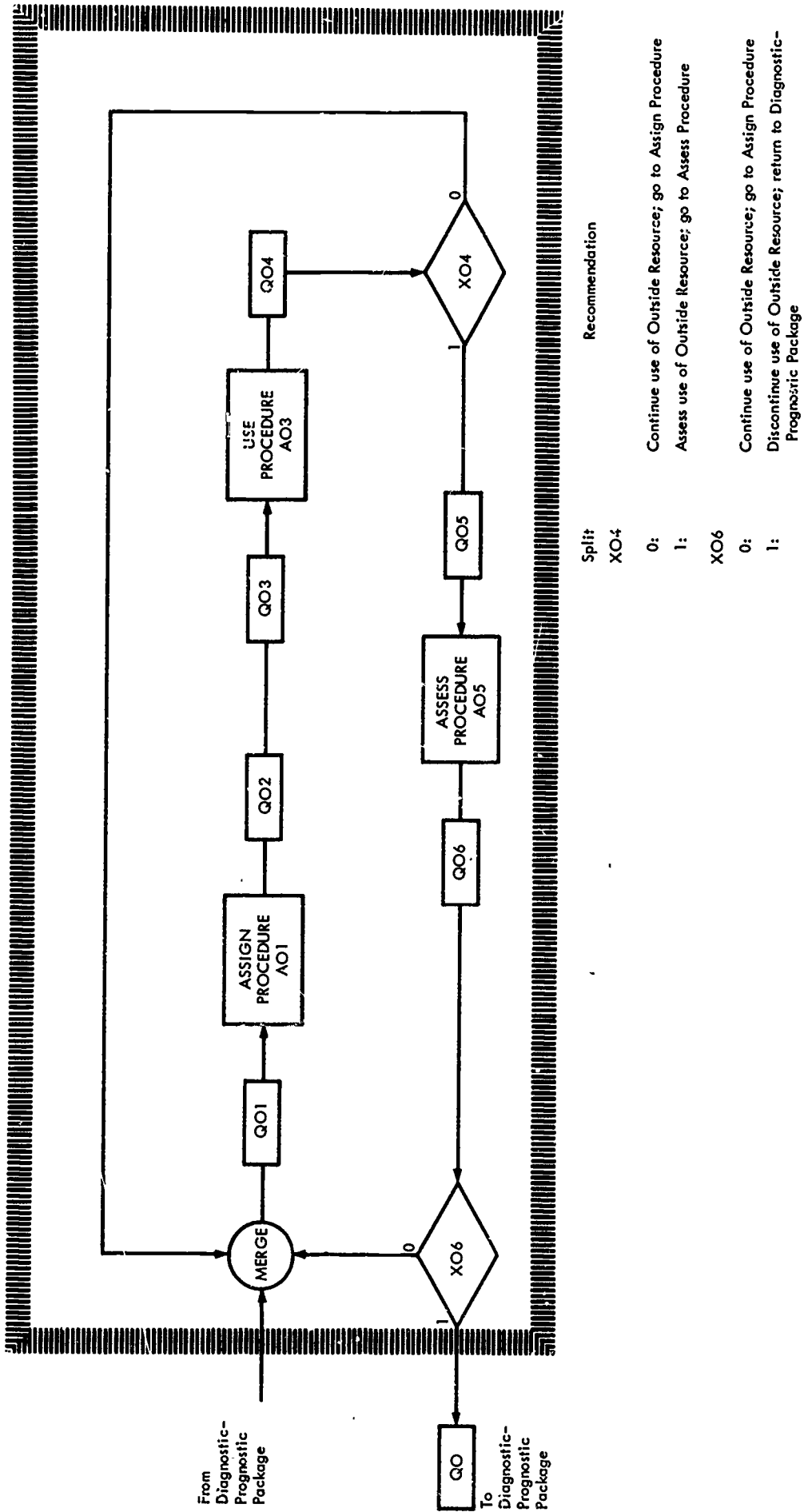

(14) FIGURE 5. FLOW DIAGRAM OF OUTSIDE RESOURCES PROCEDURES

PRECEDING PAGE BLANK-NOT FILMED

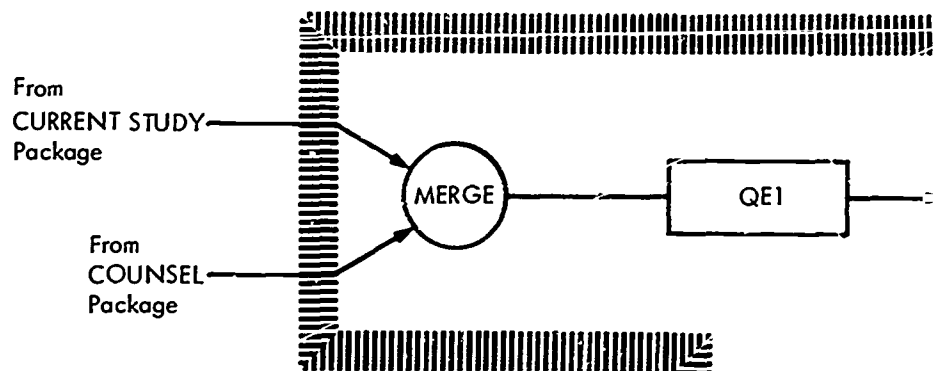

Split	Recommendations
XE2	
0:	Review Subject Performance and Make Recommendations for further Performance
1:	Review Counsel Package Recommendations for Concurrence or Rejection
XE6	
0:	Return to Counsel Package for change in activity including discontinue current unit or project in this subject
1:	New activity in this subject is appropriate, usually the next unit or project; and new activity, other than in this subject, is appropriate; go to Counsel Package via Review Concurrent Activity Procedure
2:	New activity in this subject is appropriate, the next (or first) unit or project; go to Review Concurrent Activity Procedure
3:	Continue this (or begin first) unit or project; and new activity, other than in this subject is appropriate; go to Counsel Package via Review Concurrent Activity Procedure
4:	Continue this (or begin) first unit or project; go to Review Concurrent Activity Procedure
5:	Violate #1 - Don't go to Counsel
XE8	
0:	Continue (or begin) concurrent activity, if any, in this subject; and an additional concurrent activity in this subject is also appropriate; go to Counsel Package
1:	Continue (or begin) concurrent activity, if any, in this subject; go to Counsel Package
2:	Continue (or begin) concurrent activity, if any, in this subject; go to New Study Package
3:	Continue (or begin) concurrent activity, if any, in this subject; go to Current Study Package
4:	Discontinue concurrent activity, if any, in this subject; and an additional concurrent activity in this subject is appropriate; go to Counsel Package
5:	Discontinue concurrent activity, if any, in this subject; go to Counsel Package
6:	Subject completed; go to Counsel
XE4	
0:	Counsel Package recommendation(s) are inappropriate; return to Counsel Package
1:	Counsel Package recommendation(s) require a review of prerequisite performance or this subject performance
2:	Counsel Package recommendation(s) approved; go to New Study Package Assign Procedure
3:	Counsel Package recommendation(s) approved; go to Current Study Package Assign Procedure

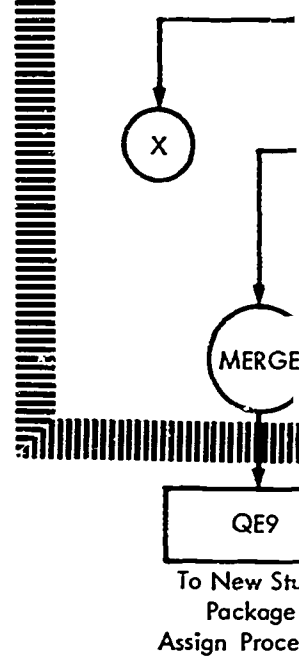

(9.3) FIGURE 6. FLOW DIAGRAM OF

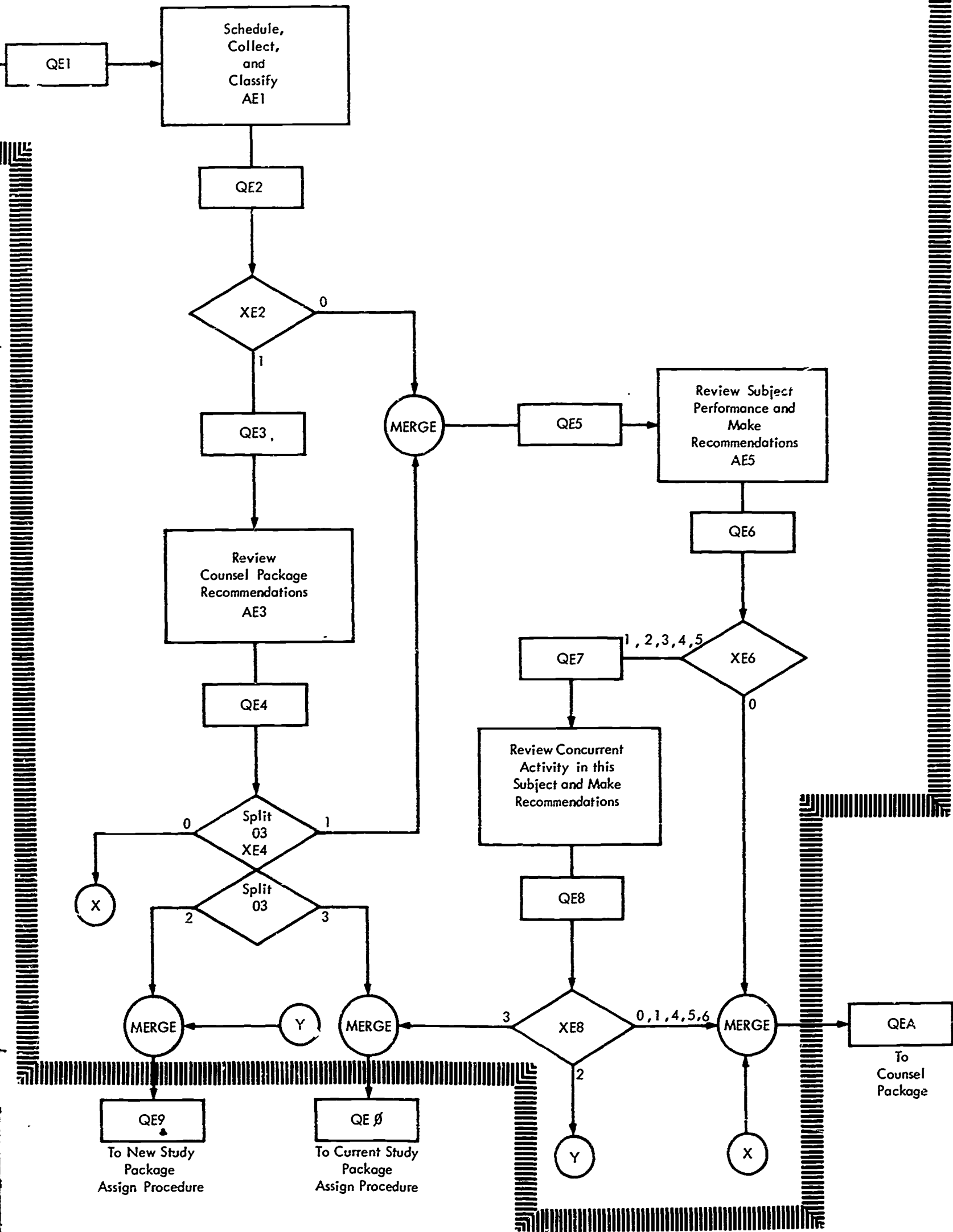

FLOW DIAGRAM OF EVALUATION PROCEDURES

6 August 1963

-35-

TM-1409

PRECEDING PAGE(S) NOT FILMED

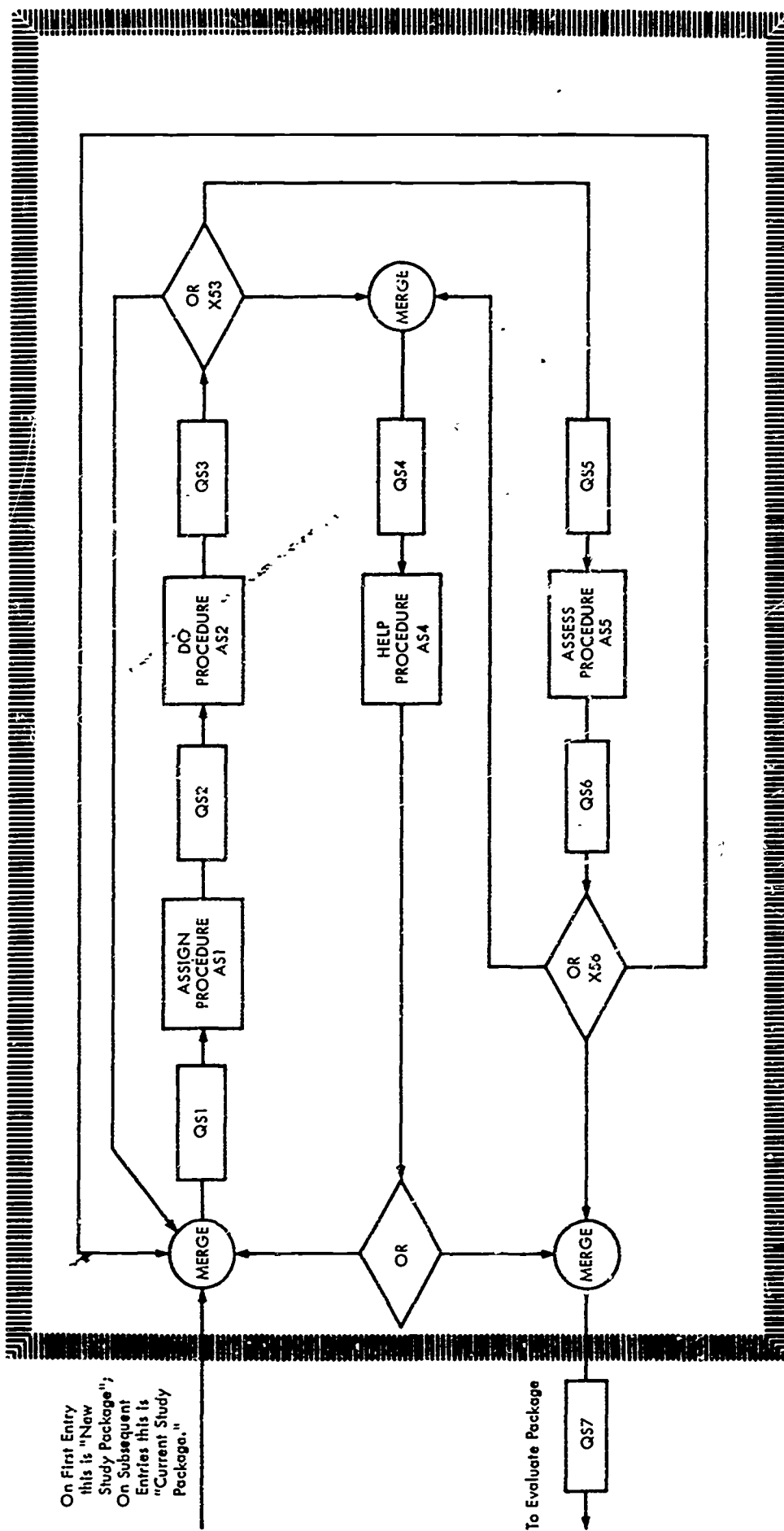

(4.2) FIGURE 7. FLOW DIAGRAM OF PROCEDURES IN STUDY PACKAGE

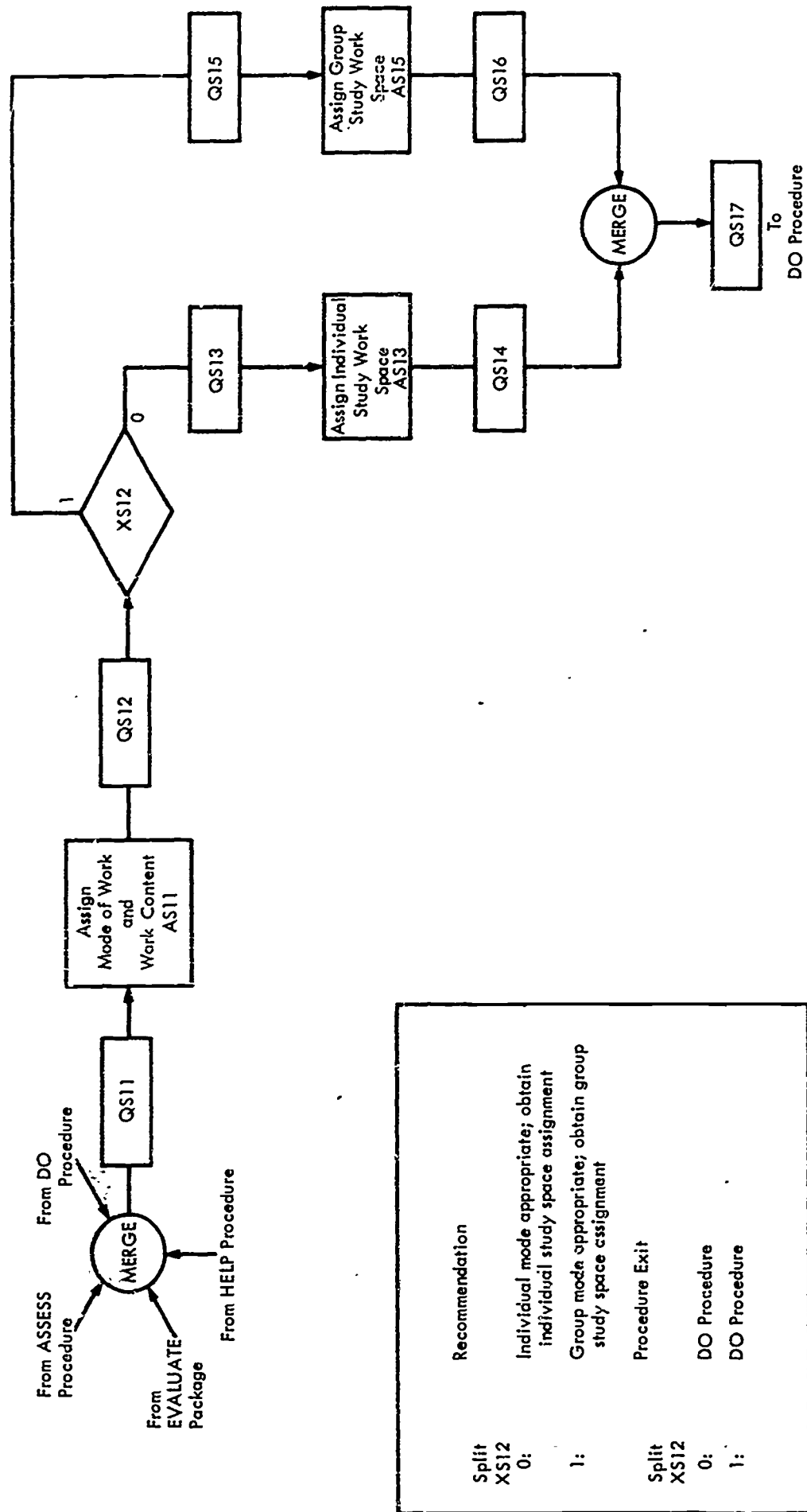

(5.1) FIGURE 8. FLOW DIAGRAM OF THE ASSIGN ACTIVITIES IN THE ASSIGN PROCEDURE OF THE STUDY PACKAGE

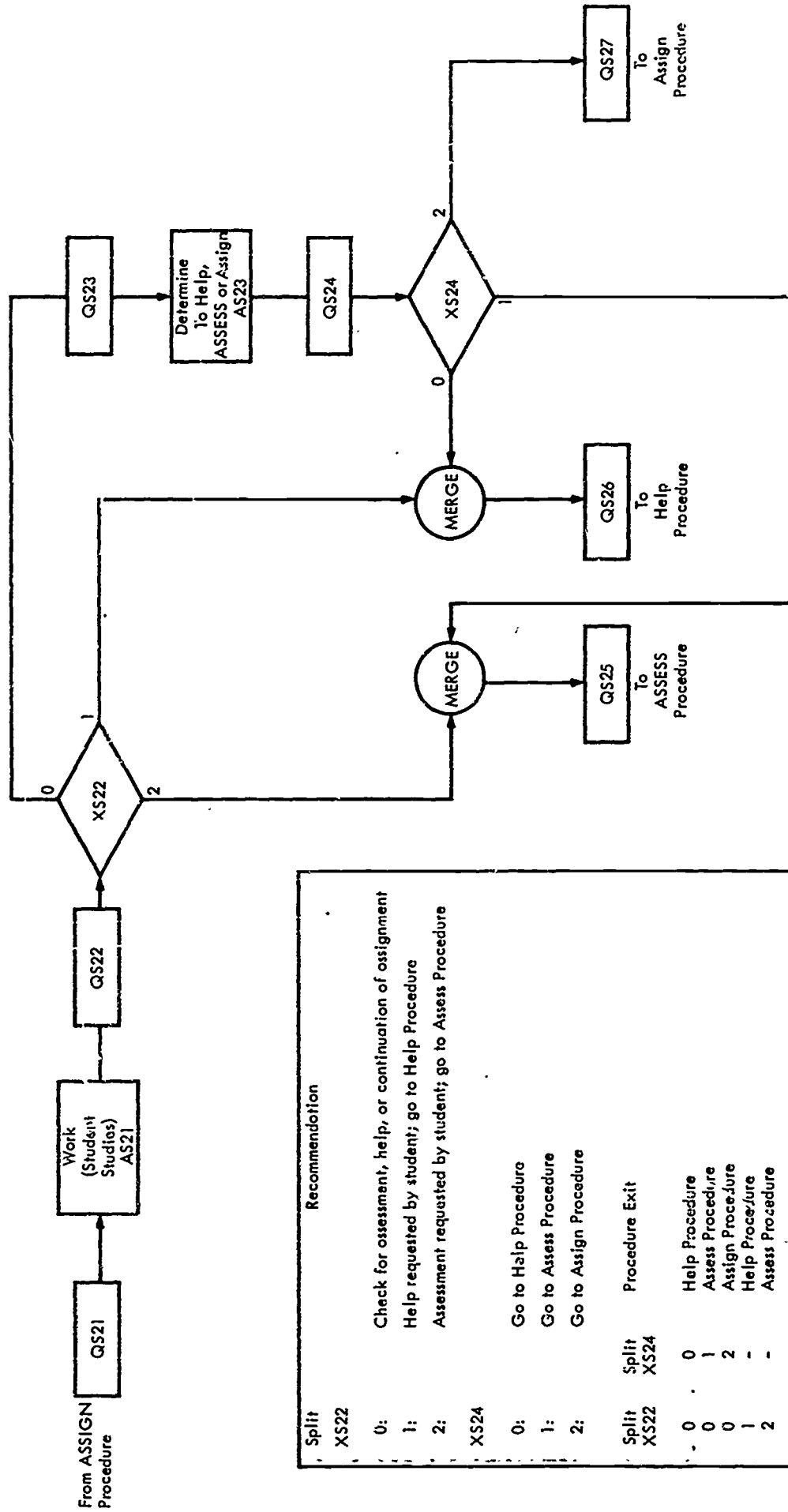

(6.2) FLOW DIAGRAM OF THE DO ACTIVITIES IN THE DO PROCEDURE OF THE STUDY PACKAGE

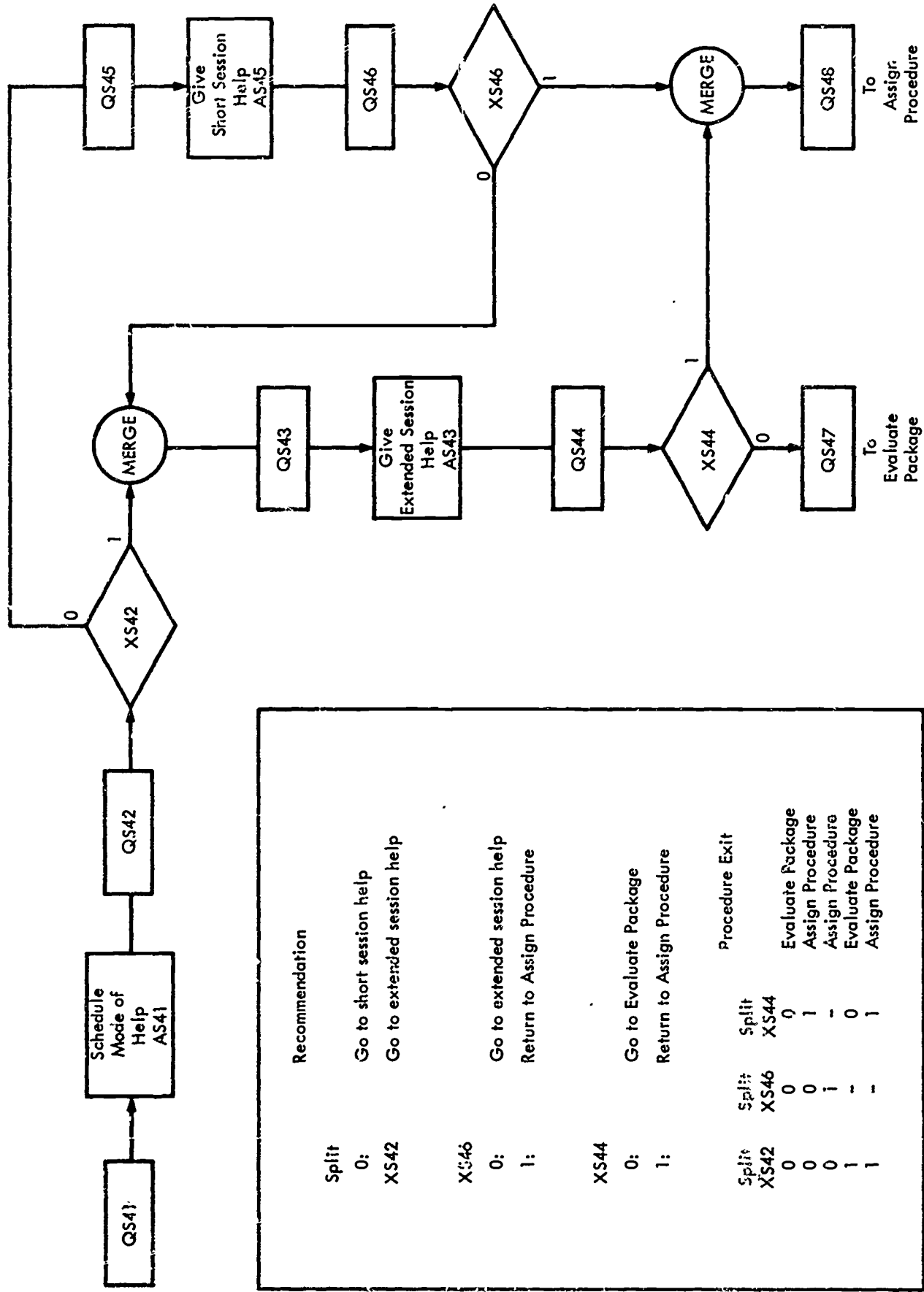

(7.2) FIGURE 10. FLOW DIAGRAM OF THE HELP ACTIVITIES IN THE HELP PROCEDURE OF THE STUDY PACKAGE

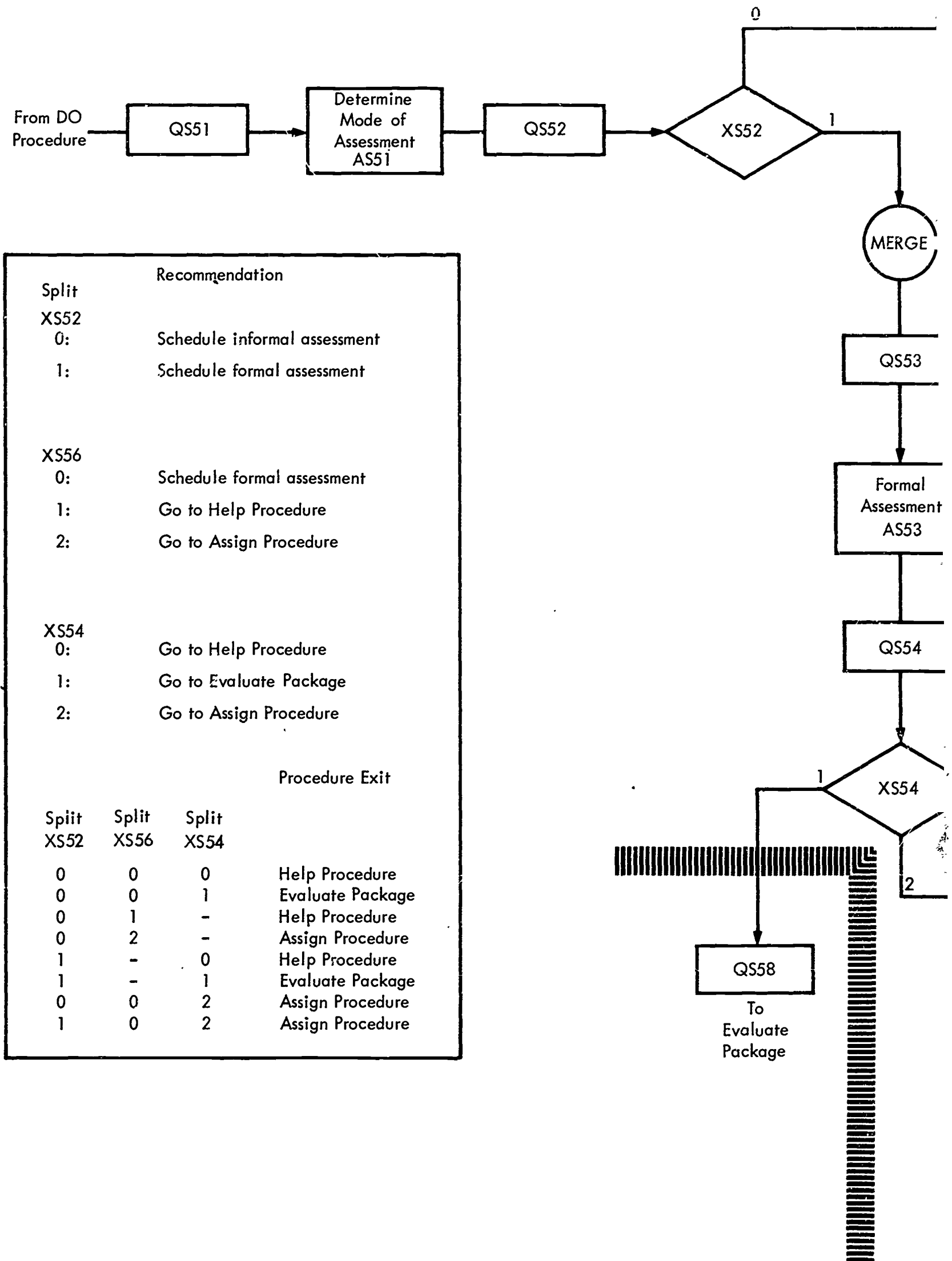

Split		Recommendation	
XS52			
0:		Schedule informal assessment	
1:		Schedule formal assessment	
XS56			
0:		Schedule formal assessment	
1:		Go to Help Procedure	
2:		Go to Assign Procedure	
XS54			
0:		Go to Help Procedure	
1:		Go to Evaluate Package	
2:		Go to Assign Procedure	
Procedure Exit			
Split	Split	Split	
XS52	XS56	XS54	
0	0	0	Help Procedure
0	0	1	Evaluate Package
0	1	-	Help Procedure
0	2	-	Assign Procedure
1	-	0	Help Procedure
1	-	1	Evaluate Package
0	0	2	Assign Procedure
1	0	2	Assign Procedure

(8.3) FIGURE 11. FLOW DIAGRAM OF THE ASSESS ACTIVITIES 0

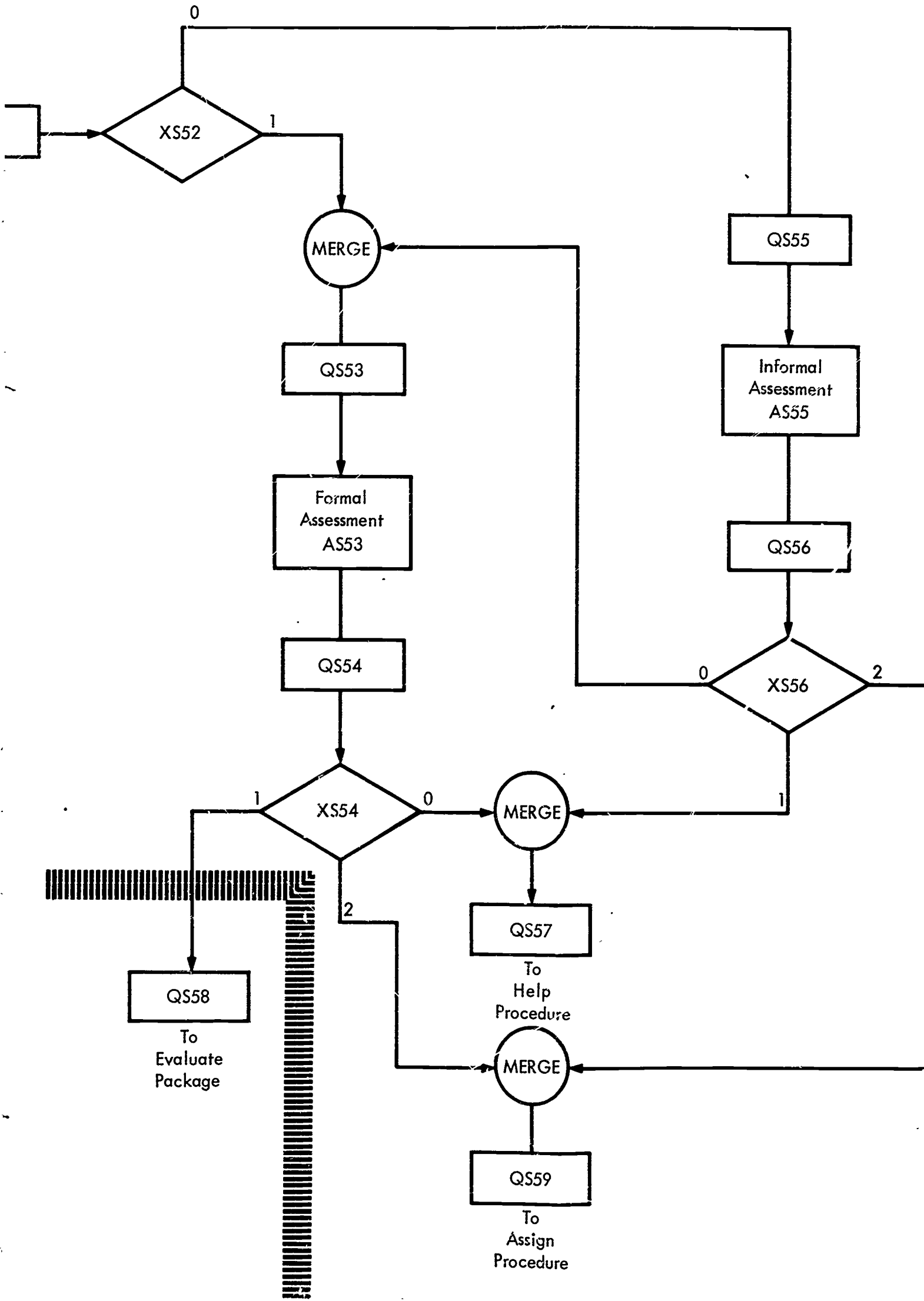

4 OF THE ASSESS ACTIVITIES OF THE ASSESS PROCEDURE OF THE STUDY PACKAGE

6 August 1963

PRECEDING PAGE BLANK-NOT FILMED

Split	Recommendations
XT2	
0:	Refuse admission to student or process student's rejection of admission; go to Terminate Applicant Procedure
1:	Approve Student Dismissal; go to Dismiss Procedure
2:	Approve Student Withdrawal; go to Withdraw Procedure
3:	Approve Student Graduation; go to Graduate Procedure

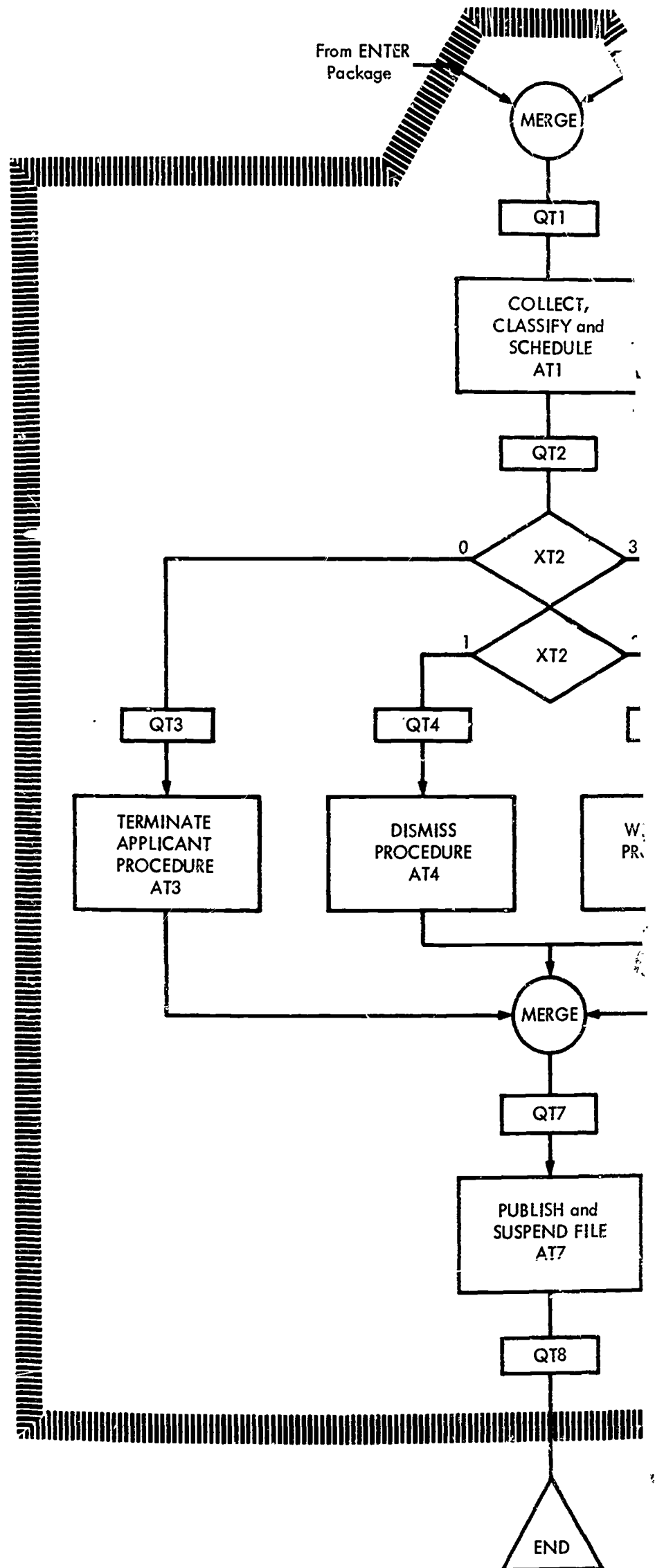

(3.1) FIGURE 12. FLOW DIAGRAM OF THE TERMINATE PROCEDURES

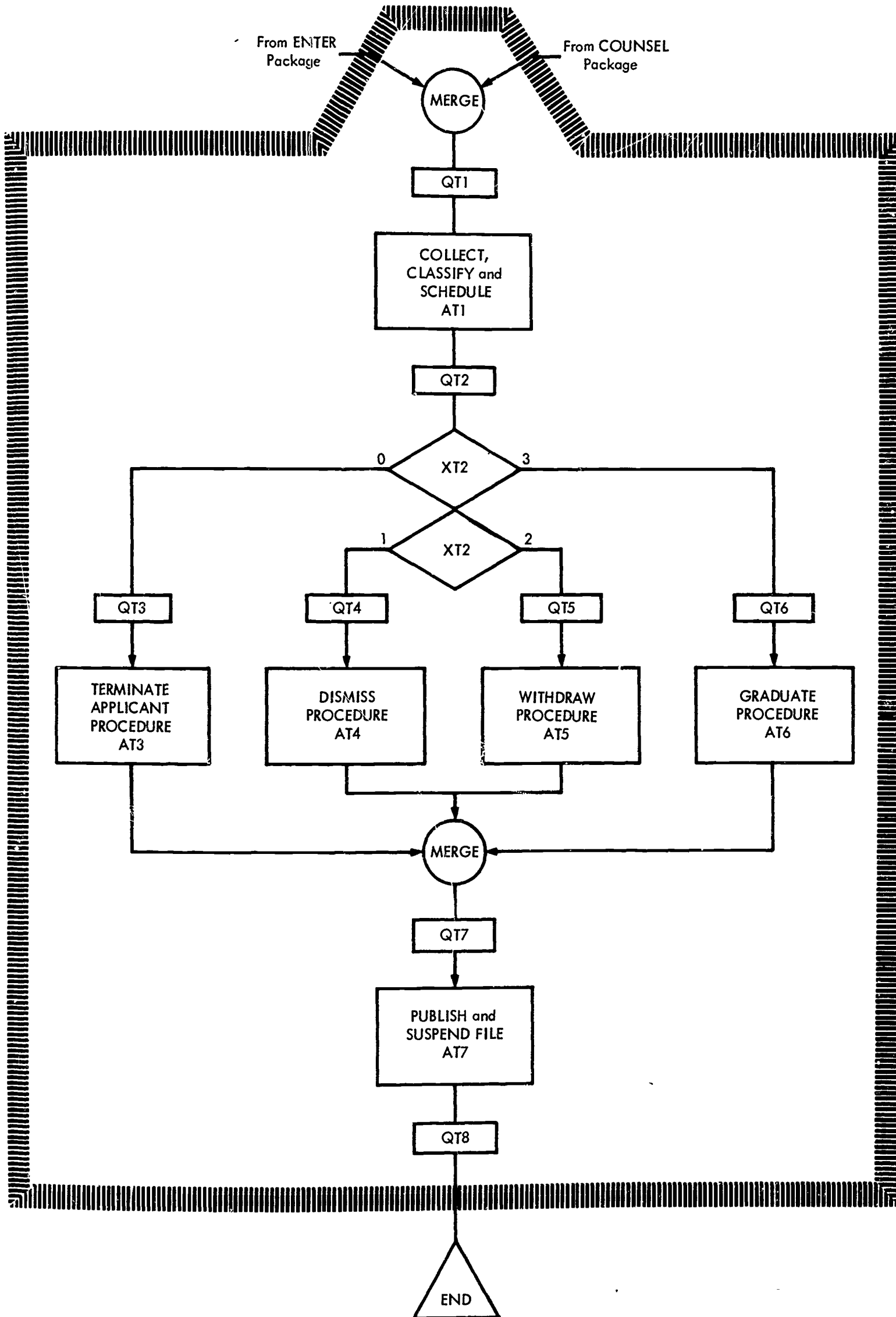

2. FLOW DIAGRAM OF THE TERMINATE PROCEDURES